

PLAN SYMBOLS

- COUNTY LINE.....
- TOWNSHIP OR RANGE LINE.....
- SECTION LINE.....
- QUARTER LINE.....
- SIXTEENTH LINE.....
- RIGHT OF WAY LINE.....
- SLOPE EASEMENT.....
- PRESENT RIGHT OF WAY.....
- PROPERTY LINE.....
- CORPORATE OR CITY LIMITS.....
- RETAINING WALL.....
- RAILROAD.....
- RAILROAD RIGHT OF WAY.....
- RIVER OR CREEK.....
- DRAINAGE DITCH.....
- CULVERT.....
- DROP INLET.....
- GAUDD RAIL.....
- BARBED WIRE FENCE.....
- WOVEN WIRE FENCE.....
- CHAIN LINK FENCE.....
- WOOD FENCE.....
- STONE WALL OR FENCE.....
- HEDGE.....

- LOWLAND.....
- TIMBER.....
- ORCHARD.....
- BRUSH.....
- NURSERY.....

- CATTLE GAUDD.....
- OVERPASS (Highway Over).....
- UNDERPASS (Highway Under).....
- BRIDGE.....

- BUILDING (One Story Frame).....
- F-FRAME C-CONCRETE.....
- S-STONE T-TILE.....
- B-BRICK ST-STUCCO.....

- RAILROAD CROSSING BELL.....
- RAILROAD CROSSING GATE.....
- MANHOLE.....
- CATCH BASIN.....
- FIRE HYDRANT.....
- CAST IRON MONUMENT.....
- IRON PIN.....
- GRAVEL PIT.....
- SAND PIT.....
- BORROW PIT.....
- ROCK QUARRY.....

UTILITY SYMBOLS

- POWER POLE LINE.....
- TELEPHONE OR TELEGRAPH POLE LINE.....
- JOINT TELEPHONE & POWER ON POWER POLES.....
- ON TELEPHONE POLES.....
- ANCHOR.....
- STEEL TOWER.....
- STREET LIGHT.....
- PEDESTAL (Cable Terminal).....
- GAS MAIN.....
- WATER MAIN.....
- TELEPHONE CABLE IN CONDUIT.....
- ELECTRIC CABLE IN CONDUIT.....
- TELEPHONE MANHOLE.....
- ELECTRIC MANHOLE.....
- BURIED TELEPHONE CABLE.....
- BURIED ELECTRIC CABLE.....
- AERIAL TELEPHONE CABLE.....
- SEWER (Sanitary or Storm).....
- SEWER MANHOLE.....

SCALES

- PLAN: 0 5m 10m 20m
- PROFILE HORIZONTAL: 0 5m 10m 20m
- PROFILE VERTICAL: 0 0.5m 1m 2m
- X-SECTIONS HORIZONTAL: 0 1m 2m 4m
- X-SECTIONS VERTICAL: 0 1m 2m 4m
- INDEX MAP: 0 0.5km 1km 2km



# MINNESOTA DEPARTMENT OF TRANSPORTATION

## ANOKA COUNTY

### CONSTRUCTION PLAN FOR CHANNELIZATION OF INTERSECTION, GRADING, DRAINAGE, AGGREGATE BASE, BITUMINOUS SURFACE, CURB & GUTTER, SIGNAL SYSTEMS, AND CONCRETE WALK.

LOCATED ON C.S.A.H. 78 FROM 0.15 km S. OF C.S.A.H. 1 TO 107TH AVE. NW (Geographic Description)

FROM A POINT 194.421 m S., 0.940 m E. OF TO A POINT 508.091 m S., 3.352 m W. OF (Legal Description)  
CENTER. SEC. 22 T31N., R24W. THE N. 1/4 COR. OF SEC. 22, T31N., R24W.

STATE PROJ. NO. 02-678-14

S.P. 114-106-03			
GROSS LENGTH	168.300	METERS	0.168 KILOMETERS
BRIDGES-LENGTH	0	METERS	0 KILOMETERS
EXCEPTIONS-LENGTH	0	METERS	0 KILOMETERS
NET LENGTH	168.300	METERS	0.168 KILOMETERS

S.P. 02-678-14, S.P. 114-020-21			
GROSS LENGTH	312.133	METERS	0.312 KILOMETERS
BRIDGES-LENGTH	0	METERS	0 KILOMETERS
EXCEPTIONS-LENGTH	0	METERS	0 KILOMETERS
NET LENGTH	312.133	METERS	0.312 KILOMETERS

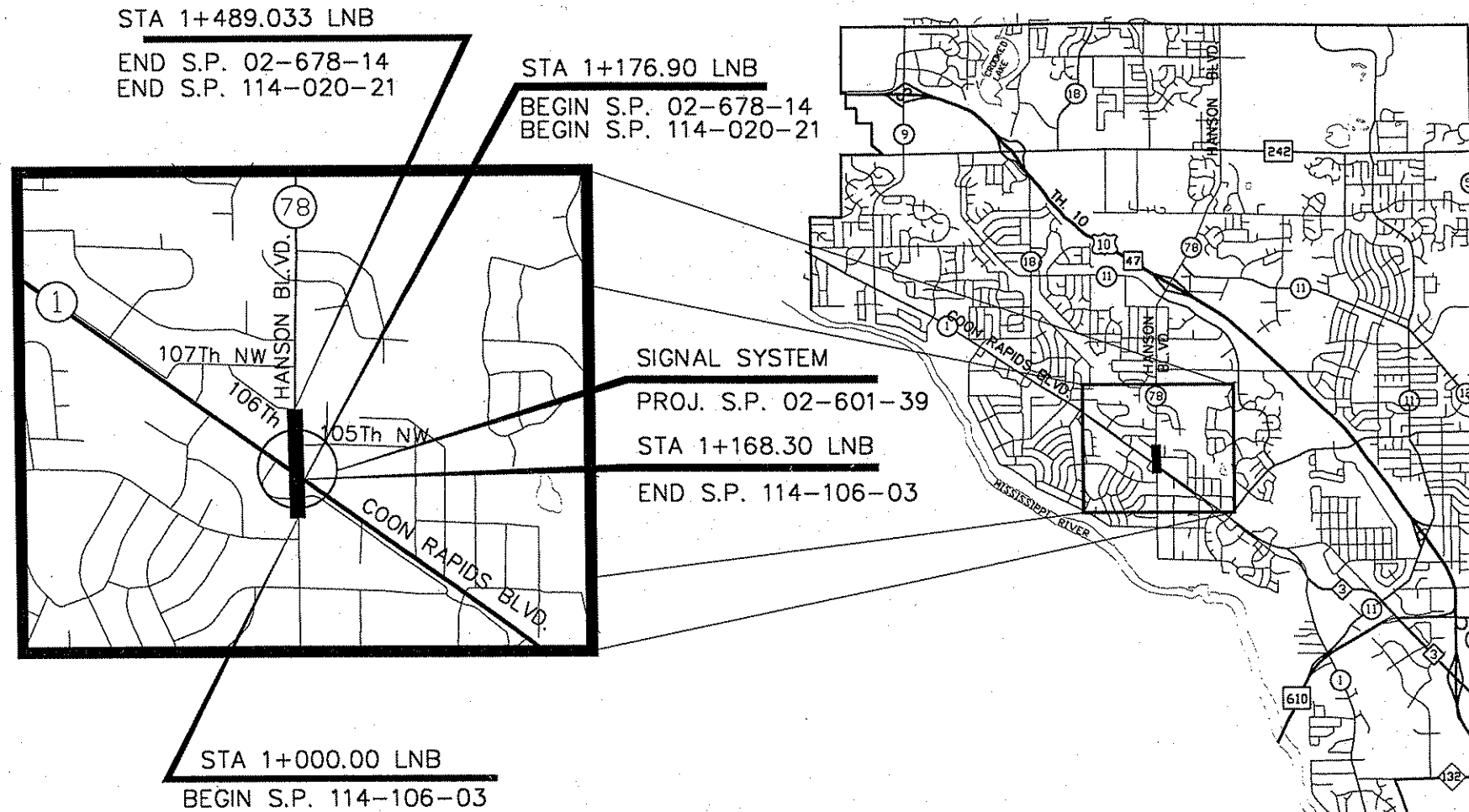

### CITY OF COON RAPIDS

MINN. PROJ. NO. STPF0298 (048)  
MINN. PROJ. NO.

GOVERNING SPECIFICATIONS

THE 1995 EDITION OF THE MINNESOTA DEPARTMENT OF TRANSPORTATION "STANDARD SPECIFICATIONS FOR CONSTRUCTION" SHALL GOVERN. ALL TRAFFIC CONTROL DEVICES SHALL CONFORM TO THE MMUTCD, INCLUDING "FIELD MANUAL FOR TEMPORARY TRAFFIC CONTROL ZONE LAYOUTS - JANUARY, 1998."

### INDEX

SHEET NO.	DESCRIPTION
1	TITLE SHEET
2 - 3	STATEMENT OF ESTIMATED QUANTITIES
4 - 6	TABULATION CHARTS
7	EARTHWORK SUMMARY
8 - 9	EROSION CONTROL DETAILS
10 - 11	TYPICAL SECTIONS
12	SPECIAL DETAILS
13 - 14	ALIGNMENT PLANS
15	EXISTING CONDITION AND REMOVAL PLAN
15 - 17	CONSTRUCTION PLAN AND PROFILE
18	STORM SEWER LATERALS
19 - 27	CROSS SECTIONS
28 - 32	TRAFFIC SIGNAL PLAN
33 - 36	SIGNING AND STRIPING PLAN
37 - 40	CONSTRUCTION STAGING PLANS

THIS PLAN CONTAINS 40 SHEETS

DESIGN DESIGNATION (URBAN)

ESAL <sub>20</sub>	2 201 952
R VALUE	50
ADT (1999)	16 000
Proj. ADT (2019)	27 100
Proj. HCADT (2019)	1 600
Soil Factor	NA
	8.2 METRIC TON DESIGN

Functional Classification ARTERIAL HIGH DENSITY  
 No. of Traffic Lanes 4 No. of Parking Lanes 0  
 Design Speed 70 Km/h  
 Based on: Stopping Sight Distance  
 Height of eye 1070 mm Height of object 150 mm  
 Design Speed not achieved at: \_\_\_\_\_

STA. \_\_\_\_\_ TO STA. \_\_\_\_\_ km/h  
 STA. \_\_\_\_\_ TO STA. \_\_\_\_\_ km/h

Approved: *[Signature]* ANOKA COUNTY ENGINEER Date: 7/30/99  
 Approved: *[Signature]* CITY OF COON RAPIDS ENGINEER Date: 8/2/99  
 Approved: *[Signature]* Metro Division State Aid Engineer: Reviewed for Compliance with State and Federal Aid Rules/Policy Date: 8/4/99  
 Approved: \_\_\_\_\_ Date: \_\_\_\_\_  
 For State and Federal Aid Funding: State Aid Engineer

I HEREBY CERTIFY THAT THIS PLAN WAS PREPARED BY ME OR UNDER MY DIRECT SUPERVISION AND THAT I AM A DULY REGISTERED PROFESSIONAL ENGINEER UNDER THE LAWS OF THE STATE OF MINNESOTA.  
*[Signature]*  
 DATE 07-09-99 REG. NO. 25066

DRAWN BY: MN DATE 07-09-99  
 DESIGN BY: MN DATE 07-09-99  
 CHECKED BY: LR DATE 07-09-99



ANOKA COUNTY  
HIGHWAY DEPT.

STATE PROJECT NO. 02-601-39  
 STATE PROJECT NO. 02-678-14  
 STATE PROJECT NO. 114-106-03  
 STATE PROJECT NO. 114-020-21

TITLE SHEET  
 Sheet 1 of 40 Sheets

DATE	BY	CKD	APPR	REVISION
01-TITLE.dwg	7-30-99			8:39:58 am EST



STATEMENT OF ESTIMATED QUANTITIES

Fed. Project No. \_\_\_\_\_

CHART NO.	ITEM NO.	ITEM	UNIT	TOTAL QUAN.		ANOKA COUNTY S.P. 02-678-14				ANOKA COUNTY S.P. 02-601-39				CITY OF COON RAPIDS S.P. 114-106-03				CITY OF COON RAPIDS S.P. 114-020-21				STORM SEWER	
				EST.	FINAL	PARTICIPATING		NON-PART.		PARTICIPATING		NON-PART.		PARTICIPATING		NON-PART.		PARTICIPATING		NON-PART.		EST.	FINAL
						EST.	FINAL	EST.	FINAL	EST.	FINAL	EST.	FINAL	EST.	FINAL	EST.	FINAL	EST.	FINAL	EST.	FINAL		
	2564.531	SIGN PANELS TYPE C	m <sup>2</sup>	25.8		25.8																	
	2564.537	INSTALL SIGN TYPE SPECIAL	EACH	2																			
	2564.602	PAVEMENT MESSAGE (LEFT ARROW) POLY PREFORM	EACH	8		8																	
	2564.602	PAVEMENT MESSAGE (RIGHT ARROW) POLY PREFORM	EACH	2		2																	
	2564.603	100 mm SOLID LINE WHITE - PAINT	m	1524		1524																	
	2564.603	100 mm BROKEN LINE WHITE - PAINT	m	29		29																	
	2564.603	100 mm SOLID LINE YELLOW - PAINT	m	462		462																	
	2564.603	100 mm DOUBLE SOLID LINE YELLOW - PAINT	m	509		509																	
	2564.603	600 mm SOLID LINE YELLOW - PAINT	m	161		161																	
	2564.603	600 mm SOLID LINE WHITE - PAINT	m	10.4		10.4																	
	2564.603	900 mm SOLID LINE WHITE - POLY PREFORMED	m	66.24		66.24																	
	2565.511	FULL TACT CONTROL SIGNAL SYSTEM	SIG SYS	1						1													
	2565.601	EMERGENCY VEHICLE PRE-EMPTION SYSTEM	LUMP SUM	1																			
6	2573.501	BALE CHECK	EACH	30		30																	
4	2573.502	SILT FENCE, TYPE PREASSEMBLED	m	294		294																	
U	2575.501	SEEDING	ha	0.30		0.30																	
U	2575.502	SEED, MIXTURE 70A	kg	15		15																	
U	2575.505	SODDING, TYPE SALT RESISTANT	m <sup>2</sup>	2242		2242																	
U	2575.511	MULCH MATERIAL TYPE 1	t	0.31		0.31																	
U	2575.519	DISK ANCHORING	ha	0.16		0.16																	
U	2575.523	EROSION CONTROL BLANKET CATEGORY 3	m <sup>2</sup>	1 455		1 455																	
U	2575.532	COMMERCIAL FERTILIZER ANALYSIS 10-10-10	kg	168		168																	
	2580.501	TEMPORARY LANE MARKING	m	980		980																	

CONSTRUCTION NOTES

- 1 INCLUDES ALL BITUMINOUS PAVEMENTS REGARDLESS OF DEPTH AND WIDTH.
- 2 FOR DUST CONTROL AS DIRECTED BY THE ENGINEER.
- 3 FOR DEPRESSED MEDIAN NOSE (STD. PLATE M7109C) AND MEDIAN ISLAND.
- 4 FOR EROSION CONTROL AS SHOWN IN THE PLANS OR AS DIRECTED BY THE ENGINEER.
- 5 FOR USE AT STORM SEWER INLETS AND DITCH CHECKS.
- 6 FOR DRIVEWAY AND BIT PARKING LOT CONSTRUCTION. INCLUDES 100 mm AGGREGATE BASE CLASS 5 AND ANY EXCAVATION AND/OR BORROW MATERIAL REQUIRED TO CONSTRUCT DRIVEWAY AND PARKING LOT TO PROPOSED ELEVATION.
- 7 INCLUDES 300 mm SUBCUT.
- 8 TO REPLACE 300 mm SUBCUT. SEE TYPICAL SECTIONS.
- 9 INCLUDES CONCRETE APRON AND DRIVEWAY QUANTITIES.
- 10 REQUIRED GRANULAR FILTER MATERIAL AND/OR FILTER FABRIC SHALL BE CONSIDERED INCIDENTAL TO THE RIP RAP
- 11 MAIL BOX SUPPORT SUPPLIED BY THE COUNTY.

CHART	SHEET No.	DESCRIPTION
A	4	CLEARING AND GRUBBING
B	4	REMOVE CONCRETE PAVEMENT
C	4	REMOVE CONCRETE CURB AND GUTTER
D	4	REMOVE BITUMINOUS PAVEMENT
E	4	SAW BITUMINOUS PAVEMENT
F	4	SAW CONCRETE PAVEMENT
G	4	DRIVEWAY BITUMINOUS REMOVAL AND CONSTRUCTION
H	4	RELOCATE HYDRANT AND VALVE
I	4	RELOCATE CURB AND STOP BOXES
J	4	ADJUST VALVE BOX-WATER
K	4	RELOCATE MAILBOX SUPPORT
L	4	REMOVE FENCE
M	5	CONSTRUCT CONCRETE CURB AND GUTTER
N	5	CONSTRUCT CONCRETE WALK
O	5	CONSTRUCT CONC. PEDESTRIAN RAMP
P	5	MILLING BITUMINOUS PAVEMENT
Q	5	CASTING SCHEDULE
R	5	CONSTRUCT TEMP. BITUMINOUS CURB
S	5	SILT FENCE
T	5	STORM SEWER TABULATION
U	6	TURF ESTABLISHMENT
V	6	SANITARY SEWER MODIFICATIONS
W	6	PUBLIC UTILITY OWNED BY MINNEGASCO
X	6	PUBLIC UTILITY OWNED BY US WEST
Y	7	OWNED BY NORTHERN STATE POWER
Z	7	EARTHWORK SUMMARY
AA	7	BASE AND BITUMINOUS QUANTITIES CHART

NO	DATE	BY	CKD	APPR	REVISION



I HEREBY CERTIFY THAT THIS PLAN WAS PREPARED BY ME OR UNDER MY DIRECT SUPERVISION AND THAT I AM A DULY REGISTERED PROFESSIONAL ENGINEER UNDER THE LAWS OF THE STATE OF MINNESOTA.

*Allyson*

DATE 07/09/99 REG. NO. 25066

DRAWN BY: MN DATE 08-17-98  
 DESIGN BY: MN DATE 08-17-98  
 CHECKED BY: KJ DATE 08-17-98



ANOKA COUNTY  
HIGHWAY DEPT.

STATE PROJECT NO. 02-601-39  
 STATE PROJECT NO. 02-678-14  
 STATE PROJECT NO. 114-106-03  
 STATE PROJECT NO. 114-020-21

STATEMENT OF ESTIMATED QUANTITIES

CLEARING AND GRUBBING (A)					
STATION	LOCATION	CLEARING		GRUBBING	
		EACH	hc	EACH	hc
1+236.714	5.121 LNB	1		1	
1+240.342	2.267 LNB	1		1	
1+248.415	-0.964 LNB	1		1	
1+221.669	1+256.644	12.121	46.636 LNB	0.065	0.065
1+274.796	1+320.045	-2.907	35.227 LNB	0.139	0.139
1+320.045	1+363.500	-3.350	49.160 LNB	0.236	0.236
1+363.500	1+412.966	-3.350	50.862 LNB	0.280	0.280
1+412.966	1+533.520	-1.045	69.050 LNB	0.807	0.807
TOTAL		3	1.527	3	1.527

REMOVE BITUMINOUS PAVEMENT (D)					
STATION TO STATION	LOCATION	DESCRIPTION		m <sup>2</sup>	
1+177.40	1+255.40	-26.65	12.31 RT LNB	Main and Shoulder	959.64
1+255.40	1+300.00	-19.35	-7.00 RT LNB	Main and Shoulder	551.37
1+300.00	1+340.35	-20.00	-7.60 RT LNB	Main and Shoulder	494.83
1+340.35	1+390.20	-19.65	-7.20 RT LNB	Main and Shoulder	638.72
1+390.20	1+480.00	6.62	RT LNB	0.30 LT. EXIST GUTTER	27.03
1+255.60	1+273.70	-6.60	39.50 RT LNB	105th Ave.	387.46
1+115.20	1+154.70	-12.65	-7.50 RT LNB	Remove for new island	144.33
1+132.12	1+154.58	-3.35	6.20 RT LNB	Remove to reduce isl.	113.29
1+000.00	1+584.778		LT. & RT. ENTRANCES	(1)	475.20
UNADJUSTED TOTAL					3791.87
ADJUSTED TOTAL					3792.00

RELOCATE CURB STOP & BOXES (I)				
STATION	LOC.	ADDRESS	REMARKS	EA.
1+297.10	RT	DEMOED	REMOVE	1
1+346.60	RT	DEMOED	REMOVE	1
1+383.70	RT	DEMOED	REMOVE	1
1+422.70	RT	DEMOED	REMOVE	1
1+473.75	RT	DEMOED	REMOVE	1
1+508.75	RT	DEMOED	REMOVE	1
TOTAL				6

REMOVE CONCRETE PAVEMENT (B)			
STATION - STATION	LOCATION	REMARKS	m <sup>2</sup>
1+134.25	1+152.70	4.80 RT LNB ISLAND	165.00
1+178.35	1+223.35	2.80 LT LNB SIDEWALK	80.65
1+202.15	1+220.25	4.80 LT LNB ISLAND	27.55
1+223.35	1+244.75	4.75 RT LNB GAS STATION APRON	32.90
1+321.05	1+234.10	5.70 LT LNB SIDEWALK	129.55
UNADJUSTED TOTAL			435.654
ADJUSTED TOTAL			436.00

SAWING BITUMINOUS PAVEMENT (E)			
STATION TO STATION	LOCATION	DESCRIPTION	m
1+177.370	1+201.921	23.048 LT - 12.313 RT LNB CSAH 78 AND CSAH 1 INTERSECTION	44.229
1+220.415	1+225.447	10.153 LT - 5.512 LT LSB RIGHT TURN LANE TO N.R. CSAH 1	6.846
1+261.444	1+269.520	39.493 RT LNB 105th LN DEVIATION	8.076
1+115.290	1+154.415	12.629 LT - 7.500 LT LNB NEW CENTER ISLAND	86.091
1+389.572	14.044 RT - 7.785 LT LSB 106th AVE AND CSAH 78 INTERSECTION	22.736	
1+389.900	1+489.000	6.161 LT LNB CONSTRUCTION WIDENING	90.100
1+132.118	1+454.579	3.335 LT - 6.197 RT LNB REDUCTION OF ISLAND	43.170
1+115.300	1+489.000	LT. & RT. ENTRANCES (1)	60.40
UNADJUSTED TOTAL			361.648
ADJUSTED TOTAL			362.000

ADJUST VALVE BOX-WATER (J)			
STATION	LOC.	REMARKS	NO. (2)
1+213.00	27.35 LT LSB	Not Required	
1+232.60	4.60 LT LSB		2
1+235.60	6.10 LT LSB		2
1+389.85	8.25 LT LSB		2
1+169.35	19.90 RT LNB	Not Required	
1+267.35	3.45 LT LNB		2
TOTAL			8

REMOVE CONCRETE CURB AND GUTTER (C)			
STATION	LOC.	DESCRIPTION	m
1+040.00	1+100.00	2.96 LT LSB S.P. 114-106-03	58.40
1+134.00	1+153.00	1.85 LT - 5.80 RT LNB S.P. 114114-106-03 (ISLAND)	33.72
1+178.26	1+260.94	5.25 LT LNB B-618	96.00
1+260.95	1.05 LT - 39.50 RT LNB	B-618	50.53
1+270.05	1.43 LT - 39.50 RT LNB	B-618	40.93
1+270.05	1+489.00	6.45 LT LNB B-618	219.92
1+201.85	1+220.70	3.00 LT LSB ISLAND	22.50
1+234.29	1+388.85	3.85 LT LSB B-618	161.50
UNADJUSTED TOTAL			683.50
ADJUSTED TOTAL			684.00

SAWING CONCRETE PAVEMENT (F)			
STATION	LOCATION	DESCRIPTION	m
1+178.90	13.70 RT LNB	SIDEWALK	1.5
1+234.20	5.95 LT LSB	SIDEWALK	1.5
1+321.05	6.40 LT LSB	SIDEWALK	1.5
1+210.50	4.65 LT LSB	ISLAND	19.0
TOTAL			23.5

RELOCATE MAIL BOX SUPPORT (K)				
STATION	ADDRESS	LOC.	DESCRIPTION	EACH
1+350.34	# 10540	21.00 LT LNB		1
1+354.34	# 10550	21.00 LT LNB		1
TOTAL				2

RELOCATE HYDRANT AND VALVE (H)					
LOCATION		DESCRIPTION	RELOCATE TO		NO.
STATION	LOCATION		STATION	LOCATION	
1+235.95	6.40 LT LSB		1+230.00	12.90 LT LSB	1
1+384.60	9.25 LT LSB		1+383.35	9.20 LT LSB	1
1+529.30	11.35 LT LSB	NO CONST. REQUIRED			
TOTAL					2

REMOVE FENCE (L)			
STATION	LOCATION	REMARKS	REMOVE m
1+275.850	27.34 RT. - 47.14 RT LNB	CHAIN LINK FENCE	10.20
1+452.456	3.32 RT. - 24.65 RT LNB	CHAIN LINK FENCE	26.30
TOTAL			36.50

DRIVEWAY BITUMINOUS REMOVAL AND CONSTRUCTION (G)																	
STATION	LOCATION	ADDRESS	SAWCUT				REMOVAL				REPLACEMENT						
			BIT	CONC.	LENGTH	WIDTH	BIT	CONC.	GRAVEL	LENGTH	WIDTH	50 mm BIT	150 mm CONC.	200 mm CONC.	APRON 150 mm CONC.		
1+195.72	1+244.40	-3.65 12.52 RT LNB	42.47		49.12	16.70	4.33										
1+274.10	4.20 LT LSB	KINNEY SHOES ENT	6.65		6.73	1.34	8.45			0.40	6.67	2.20					
1+274.10	4.20 LT LSB	KINNEY SHOES APRON			1.17	8.21	9.02			1.50	6.76	10.14			10.05	12.20	
1+348.60	24.62 23.30 LT LNB	10540	4.43		1.30	3.14	4.05										
1+363.55	24.43 23.03 LT LNB	10550	6.86		1.34	5.52	7.83										
1+248.50	1+261.50	31.00 RT LNB								13.00	6.40	88.70					
1+209.70	1+248.25	12.52 51.20 RT LNB								38.50	37.90	968.20					
1+343.80	4.90 LT LNB	10540 APRON			1.18	5.27	5.80			1.32	5.56	7.11			7.60		
1+357.40	5.35 LT LNB	10550 APRON			1.18	5.65	6.60			1.17	4.98	5.57			7.00		
1+223.35	1+244.75	4.75 RT LNB						32.90									
1+054.00	4.50 LT CL SERV.	NEW GAS STA. ENT.														9.40	
UNADJUSTED TOTAL			60.41				475.21	32.90					1081.92		10.05	14.60	21.60
ADJUSTED TOTAL			60.00				475.00	33.00					1083.00		10.00	15.00	22.00

TABULATION CHARTS

- CLEARING AND GRUBBING
- REMOVE CONCRETE PAVEMENT
- REMOVE CONCRETE CURB AND GUTTER
- REMOVE BITUMINOUS PAVEMENT
- SAWING BITUMINOUS PAVEMENT
- SAWING CONCRETE PAVEMENT
- DRIVEWAY BITUMINOUS PAVEMENT
- RELOCATE HYDRANT AND VALVE
- RELOCATE CURB STOP AND BOXES
- ADJUST VALVE BOX-WATER
- MAIL BOX SALVAGE AND INSTALL
- REMOVE FENCE

NO	DATE	BY	CKD	APPR	REVISION
NAME: 03-tab-sh1.DWG	9-20-99	2:00:58 pm	EST		



I HEREBY CERTIFY THAT THIS PLAN WAS PREPARED BY ME OR UNDER MY DIRECT SUPERVISION AND THAT I AM A DULY REGISTERED PROFESSIONAL ENGINEER UNDER THE LAWS OF THE STATE OF MINNESOTA.

*Albert*

DATE 07/09/99 REG. NO. 25066

DRAWN BY: MN DATE 02-21-99

DESIGN BY: MN DATE 02-21-99

CHECKED BY: LAR DATE 02-21-99

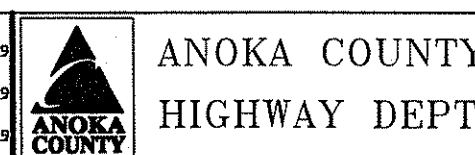

STATE PROJECT NO. 02-601-39

STATE PROJECT NO. 02-678-14

STATE PROJECT NO. 114-106-03

STATE PROJECT NO. 114-020-21



TURF ESTABLISHMENT										
STA. TO STA.		LOCATION	SOD	SEEDING	SEED	MULCH	DISK ANCHORING	FIBER BLANKET	FERTILIZER	
			m <sup>2</sup>	ha	kg	t	ha	m <sup>2</sup>	kg	(U)
1+179.70	1+248.30	10.80-12.50	RT LNB	168.75						
1+185.70	1+381.00	6.30- 9.00 BLVD.	RT LNB	518.10						
1+248.30	1+335.00	10.80-15.00 DITCH	RT LNB	699.70						
1+248.30	1+261.00	RT GAS STA. ENT.	RT LNB	39.20						
1+270.00	1+395.70	3.12 m RT SERVICE RD.	RT LNB	444.85						
1+335.00	1+387.70	10.80- 11.30	RT LNB	34.80						
1+335.00	1+387.70	2.00 m LT SERVICE RD	RT LNB	79.60						
1+335.00	1+386.50	POND AREA	RT LNB		0.0776	3.88		776	43.46	
1+395.65	1+440.00	POND AREA	RT LNB		0.1730	8.65	0.210	0.1052	679	96.82
1+440.00	1+489.00	TEMPORARY CONST.	RT LNB		0.0494	2.47	0.099	0.0494		27.66
1+234.50	1+321.10	EAST SIDEWALK	LT LSB	112.70						
1+234.50	1+321.10	WEST SIDEWALK	LT LSB	50.10						
1+321.10	1+381.00	EAST SIDEWALK	LT LSB	66.40						
1+378.10	1+387.95	WEST SIDEWALK	LT LSB	28.00						
UNADJUSTED TOTAL				2242.20	0.3000	15.00	0.309	0.1546	1455.00	167.94
ADJUSTED TOTAL				2242.00	0.3000	15.00	0.310	0.160	1455.00	168.00

SANITARY SEWER MODIFICATIONS												
STRUCT. NO.	STATION	LOCATION	INPL.	EXISTING SAN. SEWER			NEW CONST.					REMARKS
				INPLACE TOP ELEV.	PROP. TOP ELEV.	ADJUST EACH	ADJUST CASTING	TOP CAST ELEV.	INVERT ELEV.	PAY HT. m	CASTING HI	
1	1+139.950	8.866 LT LNB	MH	263.674		1						
2	1+207.830	29.700 LT LNB	MH	264.180	264.116							NO CONSTRUCTION REQUIRED
3	1+237.819	9.854 LT LNB	MH	264.179	264.121	2	(1)	-0.063	264.116	260.460	1.827	0.178
4	1+269.617	10.823 LT LNB	MH	264.054		2	(1)	0.067	264.121	259.512	1.439	0.178
5	1+393.079	10.806 LT LNB		264.241								NO CONSTRUCTION REQUIRED
TOTAL=						5					3.266	

(1) 2 ADJUSTS FOR EACH STRUCTURE ANTICIPATED DUE TO TIMING OF FINAL PAVING COURSE.

PUBLIC UTILITY OWNED BY NORTHERN STATE POWER			
STATION	LOCATION	DESCRIPTION	#
1+075.20	3.45 LT LSB	POWER POLE	1
1+133.25	2.40 LT LSB	POWER POLE	1
1+167.45	30.60 LT LSB	POWER POLE	1
1+185.40	56.90 LT LSB	POWER POLE	1
1+231.55	43.75 LT LSB	POWER AND LIGHT POLE	1
1+250.85	71.90 LT LSB	POWER AND LIGHT POLE	1
1+232.50	10.20 LT LSB	POWER POLE	1
1+262.45	4.20 LT LSB	POWER POLE	1
1+321.95	5.40 LT LSB	POWER POLE	1
1+382.40	6.25 LT LSB	POWER POLE	1
1+427.35	7.10 LT LSB	POWER POLE	1
1+526.80	7.00 LT LSB	POWER POLE	1
1+113.20	35.60 RT LNB	POWER POLE	1
1+155.30	50.65 RT LNB	POWER POLE	1
1+220.85	1.40 LT LNB	LIGHT POLE-PRIVATE*	1
1+274.45	1.50 LT LNB	POWER POLE	1
1+274.45	28.50 RT LNB	POWER POLE	1
1+320.75	5.90 LT LNB	POWER POLE	1
1+365.60	4.35 LT LNB	POWER POLE	1
1+425.75	3.90 LT LNB	POWER POLE	1
1+485.90	2.15 LT LNB	POWER POLE	1
TOTAL			21

\* REMOVE BY OTHERS

PUBLIC UTILITY OWNED BY MINNEGASCO				
STATION	LOCATION	TO STATION	LOCATION	SIZE AND ITEM
1+230.00	3.05 LT LNB	1+523.95	3.10 LT LNB	75mm STEEL
1+003.80	3.40 RT LNB	1+186.80	4.10 LT LNB	150mm STEEL
1+186.80	4.10 LT LNB	1+526.25	5.10 LT LNB	150mm STEEL
1+146.15	59.40 RT LNB	1+186.80	4.10 LT LNB	150mm STEEL
1+166.55	26.85 RT LNB	1+224.40	4.80 LT LNB	150mm STEEL

PUBLIC UTILITY OWNED BY US WEST				
STATION	LOCATION	TO STATION	LOCATION	DESCRIPTION
1+052.80	2.65 RT LNB	1+190.10	0.70 RT LNB	BURIED TELEPHONE
1+190.10	0.70 RT LNB	1+274.40	4.40 LT LNB	BURIED TELEPHONE
1+274.40	4.40 LT LNB	1+418.25	3.80 LT LNB	BURIED TELEPHONE
1+418.25	3.80 LT LNB	1+485.80	3.60 LT LNB	BURIED TELEPHONE
1+190.10	0.70 RT LNB	1+187.00	3.80 RT LNB	BURIED TELEPHONE
1+187.00	3.80 RT LNB	1+162.15	42.10 RT LNB	BURIED TELEPHONE
1+190.10	0.70 RT LNB	1+251.80	91.30 LT LNB	BURIED TELEPHONE
1+263.00	4.30 LT LSB	1+274.80	13.90 RT LSB	BURIED TELEPHONE
1+187.00	3.45 RT LNB			TELEPHONE MANHOLE
1+187.60	0.25 LT LNB			TELEPHONE MANHOLE
1+052.90	2.50 RT LNB			TELEPHONE SPLICEBOX
1+274.65	2.60 LT LNB			TELEPHONE SPLICEBOX
1+382.10	7.80 LT LNB			TELEPHONE MANHOLE
1+418.55	3.90 LT LNB			TELEPHONE SPLICEBOX
1+485.95	3.95 LT LNB			TELEPHONE SPLICEBOX

ANTICIPATED RELOCATION BY OTHERS.  
ALL DISTANCES ARE IN METERS.  
LOCATIONS OF UTILITIES ARE APPROXIMATE ONLY.  
ACTUAL LOCATIONS ARE TO BE DETERMINED IN THE FIELD DURING CONSTRUCTION.

TABULATION CHARTS

TURF ESTABLISHMENT  
SANITARY SEWER MODIFICATION  
PUBLIC UTILITY OWNED BY NORTHERN STATE POWER  
PUBLIC UTILITY OWNED BY MINNEGASCO  
PUBLIC UTILITY OWNED BY U.S. WEST

EARTHWORK SUMMARY (7)

BALANCE

Fed. Project No. \_\_\_\_\_

EXCAVATION

COMMON EXCAVATION TOTAL = 8 076 m <sup>3</sup>	COMMON EXC. . . . . 6 574 m <sup>3</sup>	REGULAR . . . . . 4 226 m <sup>3</sup> ①	SP 02-678-14
		SUBCUT . . . . . 1 678 m <sup>3</sup>	
		TOPSOIL . . . . . 670 m <sup>3</sup>	
COMMON EXC. . . . . 1 383 m <sup>3</sup>	COMMON EXC. . . . . 1 383 m <sup>3</sup>	REGULAR . . . . . 793 m <sup>3</sup> ②	SP 114-020-21
		SUBCUT . . . . . 485 m <sup>3</sup>	
		TOPSOIL . . . . . 105 m <sup>3</sup>	
COMMON EXC. . . . . 119 m <sup>3</sup>	COMMON EXC. . . . . 119 m <sup>3</sup>	③	SP 114-020-03

COMMON EXCAVATION . . . 8 076 - 243 = 7 833 m<sup>3</sup> (PAY ITEM)

EMBANKMENT (CV)

SP 02-678-14	
EMBANKMENT (REG.) . . . . .	220 m <sup>3</sup>
SELECT GRANULAR . . . . .	1 678 m <sup>3</sup> ④
TOPSOIL BORROW . . . . .	180 m <sup>3</sup>
TOPSOIL SALVAGE . . . . .	90 m <sup>3</sup>
SP 114-020-21	
EMBANKMENT (REG.) . . . . .	29 m <sup>3</sup>
SUBCUT . . . . .	485 m <sup>3</sup>
TOPSOIL BORROW . . . . .	45 m <sup>3</sup>
TOPSOIL SALVAGE . . . . .	25 m <sup>3</sup>

- SOIL FACTORS:
- (1) REGULAR GRADING AND TOPSOIL DRESSING (EV TO CV): 80% SHRINKAGE
  - (2) SUBCUT COMPACTION (EV TO CV): 90% SHRINKAGE
  - (3) SELECT GRANULAR BORROW (CV TO LV): 120% SWELL
  - (4) TOPSOIL BORROW (CV TO LV): 120% SWELL

- ① INCLUDES 176 m<sup>3</sup> OF BITUMINOUS AND CONC. PAVEMENT REMOVALS.
- ② INCLUDES 8 m<sup>3</sup> OF BITUMINOUS AND CONC. PAVEMENT REMOVALS. (SEE REMOVAL CHARTS FOR PAY ITEMS.)
- ③ INCLUDES 59 m<sup>3</sup> OF BITUMINOUS AND CONC. PAVEMENT REMOVALS.
- ④ REPLACE EXCAVATION SUBCUT WITH SELECT GRANULAR MATERIAL.

SP 02-678-14

TOPSOIL  
 [(TOPSOIL STRIPPING (EV) x SHRINKAGE FACTOR) - (TOPSOIL DRESSING - TOPSOIL BORROW) (CV) FACTOR] = EXCESS (+) OR SHORTAGE (-)  
 (469 x 0.80) - (270 - 180) = 285 m<sup>3</sup> EXCESS (CV). (SEE NOTE 21.)  
 285 x 1.20 = 342 m<sup>3</sup> EXCESS (LV).

TOPSOIL BORROW  
 BORROW (CV) x SWELL FACTOR = BORROW (LV)  
 180 x 1.2 = 216 m<sup>3</sup> (LV) (PAY ITEM)

EMBANKMENT MATERIAL  
 [(REG. EXCAVATION (EV) - REMOVALS) x SHRINKAGE FACTOR] + [SUBCUT x SHRINKAGE FACTOR] - [REG. EMBANKMENT (CV) + SUBCUT] = SHORTAGE (-) OR EXCESS (+).  
 [(4 226 - 176) x 0.80] + (1 678 x 0.90) - [77 + 1 678] = + 2 995 m<sup>3</sup> EXCESS (CV)  
 (REG. EXC. (CV) x SWELL FACTOR) + (SUBCUT EXC. (CV) x SWELL FACTOR) = EXCESS (LV)  
 (2 995 x 1.20) + (1 678 x 1.20) = 5 608 m<sup>3</sup> (LV)

SP 114-020-21

TOPSOIL  
 (105 x 0.80) - (70 - 45) = 59 m<sup>3</sup> EXCESS (CV). (SEE NOTE 21.)  
 59 x 1.20 = 70.80 m<sup>3</sup> EXCESS (LV).

TOPSOIL BORROW  
 SHORTAGE (CV) x SWELL FACTOR = BORROW (LV)  
 45 x 1.2 = 54 m<sup>3</sup> (LV) (PAY ITEM)

EMBANKMENT MATERIAL  
 [(793 - 8) x 0.80] + (485 x 0.90) - [29 + 485] = + 551 m<sup>3</sup> EXCESS (CV)

SOILS AND CONSTRUCTION NOTES:

- TOP OF GRADING GRADE IS DEFINED AS THE BOTTOM OF THE AGGREGATE BASE.
- IN FILL AREAS, THE SUBGRADE SHALL BE CONSTRUCTED WITH SELECTED GRADING MATERIAL.
- SELECTED GRADING MATERIALS SHALL CONSIST OF SELECT GRANULAR MATERIALS.
- GRANULAR MATERIAL, REGARDLESS OF SOURCE, SHALL MEET THE REQUIREMENTS OF SPEC. 3149.2B.
- COMPACTION OF THE GRADING PORTION OF THIS PROJECT SHALL BE BY THE "SPECIFIED DENSITY METHOD".
- TEST ROLLING WILL NOT BE REQUIRED.
- BITUMINOUS OR CONCRETE ITEMS REMOVED BY CONSTRUCTION SHALL BECOME THE PROPERTY OF THE CONTRACTOR AND SHALL BE EITHER RECYCLED OR DISPOSED OF IN ACCORDANCE WITH THE REQUIREMENTS OF 2104.3C3 WITH NO DIRECT COMPENSATION MADE THEREFORE.
- DISPOSITION OF EXCESS EXCAVATED MATERIAL SHALL BE IN ACCORDANCE WITH THE REQUIREMENTS OF 2105.3D WITH NO DIRECT COMPENSATION THEREFORE.
- WHERE MATCHING INTO THE INPLACE ROADWAY AT THE ENDS OF CONSTRUCTION, CUT VERTICALLY TO THE TOP OF THE GRADING GRADE, AND THEN AT A 20:1 TAPER TO THE BOTTOM OF THE RECOMMENDED SUBGRADE EXCAVATION.
- WHERE CONNECTING NEW SURFACING TO AN INPLACE PAVEMENT, THE EXCAVATION SHALL BE BACKFILLED PROMPTLY TO AVOID UNDERMINING THE INPLACE PAVEMENT.
- USE TACK COAT BETWEEN ALL BITUMINOUS MIXTURES PRIOR TO PLACING BITUMINOUS MIXTURES AND PRIOR TO PLACING ANY BITUMINOUS MIXTURES ON EXISTING CONCRETE OR BITUMINOUS SURFACES. THE BITUMINOUS TACK COAT MATERIAL SHALL BE APPLIED AT UNIFORM RATE OF 0.23 L/m<sup>2</sup> BETWEEN BITUMINOUS LAYERS. THE APPLICATION RATES ARE FOR UNDILUTED EMULSION (AS SUPPLIED FROM THE REFINERY); ASPHALT EMULSION MAY BE FURTHER DILUTED IN THE FIELD IN ACCORDANCE WITH SPEC. 2357.
- COMPACTION OF THE AGGREGATE BASE LAYERS SHALL BE BY THE "SPECIFIED DENSITY METHOD", UNLESS RECYCLED MATERIAL'S.
- PLACE MINIMUM 100 mm TOPSOIL OR SLOPE DRESSING ON ALL AREAS DISTURBED BY CONSTRUCTION AND SCHEDULED FOR PERMANENT TURF ESTABLISHMENT. FERTILIZE WITH COMMERCIAL FERTILIZER, ANALYSIS 10-10-10, AT A RATE OF 560 kg PER ha.
- USE MIXTURE 70A SEED AND TYPE 1 MULCH IN AREAS TO BE SEEDED.
- SOD ALL MAINTAINED LAWNS DISTURBED BY CONSTRUCTION.
- ALL SOD UTILIZED WITHIN THE PROJECT LIMITS SHALL MEET THE REQUIREMENTS OF SPEC. 3878.2C (LAWN SOD).
- ORGANIC AND NONGRANULAR EXCAVATED MATERIAL MAY BE USED IN EMBANKMENT CONSTRUCTION IN AREAS OUTSIDE OF A 1 1/2:1 SLOPE FROM THE BACK OF CURB, OR GRADING P.I.
- BITUMINOUS REMOVAL QUANTITY BASED ON SQUARE METER REMOVED. IN PLACE SURFACE ASSUMED TO BE 244 mm IN DEPTH. CONTRACTOR SHALL INVESTIGATE AND MAKE OWN DETERMINATION OF ACTUAL PAVEMENT DEPTH.
- ALL SILT FENCING AS SHOWN IN THE PLANS SHALL BE IN PLACE PRIOR TO THE COMMENCEMENT OF GRADING OPERATIONS.
- A DOUBLE ROW OF BALE CHECKS SHALL BE INSTALLED ALONG DITCH RUNS FOR EROSION CONTROL AS DIRECTED BY THE ENGINEER.
- TOPSOIL STRIPPINGS TO BE SALVAGED AND UTILIZED TO ITS FULLEST EXTENT WITHIN THE PROJECT LIMITS.

BASE AND BITUMINOUS QUANTITIES CHART

STATION - STATION	LOCATION	DESCRIPTION	BIT. SURFACE CONSTRUCTION AREA m <sup>2</sup>	BITUMINOUS				AGGREGATE			SELECT GRANULAR 300 mm m <sup>3</sup>
				WEARING C. 50 mm t	BINDER COURSE 50 mm t	BASE COURSE 80 mm t	TACK COAT LITERS	BASE AREA m <sup>2</sup>	BASE CL-5 150 mm m <sup>3</sup>	BASE CL-5 200 mm m <sup>3</sup>	
CITY OF COON RAPIDS S.P. 114-106-03											
1+115.30	1+157.00	7.20 m LT LNB	2088.000	245.340			480.240				
1+115.30	1+157.00	7.20 m LT LNB	47.060	5.530	6.193		10.824	95.120	14.268		
1+133.20	1+157.00	12.32 m LT LNB	137.980	16.213	18.158		31.735	160.924	24.139		
CITY OF COON RAPIDS S.P. 114-020-21											
1+046.90	1+202.00	4.05 m LT CL	672.500	79.019	88.501		154.675	765.500	114.824		
1+046.90	1+202.00	4.05 m RT CL	730.000	85.775	96.068		167.900	814.300	122.145		
ANOKA COUNTY S.P. 02-678-14											
1+214.50	1+227.40	1.00 m RT LNB	137.000	16.098	18.029	27.688	63.020	165.928		35.013	
1+196.80	1+389.90	10.00 m LT LNB	97.650	11.474			22.460			50448	
1+194.30	1+389.90	4.20 m LT LNB	846.400	99.452	111.386	171.057	389.344	1021.390		215.330	
1+188.60	1+389.90	1.00 m RT LNB	722.600	84.906	95.094	146.037	332.396			310.469	
1+294.50	1+396.40	3.90 m RT LNB	1004.500	118.029	132.192	203.009	462.070	1063.575		215.843	
1+182.90	1+310.00	6.00 m LT LNB	300.000	35.250	39.480	60.630	138.000	359.160		319.559	
1+176.90	1+396.40	3.60 m LT & RT LNB	937.400	110.145	123.362	189.449	431.204	1140.800		74.964	
1+310.00	1+396.40	3.60 m LT & RT LNB	621.500	73.026	81.789	125.605	285.890	621.500		228.160	
1+202.30	1+248.30	3.90 m RT LNB	704.400	82.767	92.699	142.359	324.024	914.084		124.300	
1+396.54	1+480.90	LT & RT LNB	456.648	53.656	60.095		105.029	513.190	114.449	186.450	
										279.081	
UNADJUSTED TOTAL			9372.816	1116.677	902.952	1065.835	3398.811	7635.471	389.826	1089.669	1535.463
ADJUSTED TOTAL			9373.000	1117.000	903.000	1066.000	3399.000	7635.000	390.000	1090.000	1535.000

NOTES:  
 TACK COAT INCLUDES TWO LAYERS. (0.23 L/m<sup>2</sup>)  
 TACK COAT INCLUDE ONE LAYER IN OVERLAYS AREA.  
 6 mm BITUMINOUS THICKNESS ADDED TO BINDER AND BASE COURSES.

TABULATION CHARTS

EARTHWORK SUMMARY, CONSTRUCTION NOTES  
 BASE AND BITUMINOUS QUANTITIES CHART

1	10-27-99	M.N.			
NO	DATE	BY	CHKD	APPR	REVISION
NAME: 07-Earthw.dwg	10-27-99	11:36 pm EST			



I HEREBY CERTIFY THAT THIS PLAN WAS PREPARED BY ME OR UNDER MY DIRECT SUPERVISION AND THAT I AM A DULY REGISTERED PROFESSIONAL ENGINEER UNDER THE LAWS OF THE STATE OF MINNESOTA.  
 DATE 07/09/99 REG. NO 25066

DRAWN BY: MN DATE 12/22/98  
 DESIGN BY: MN DATE 12/22/98  
 CHECKED BY: LR DATE 12/22/98



ANOKA COUNTY  
 HIGHWAY DEPT.

STATE PROJECT NO. 02-601-39  
 STATE PROJECT NO. 02-678-14  
 STATE PROJECT NO. 114-106-03  
 STATE PROJECT NO. 114-020-21

TABULATION CHARTS

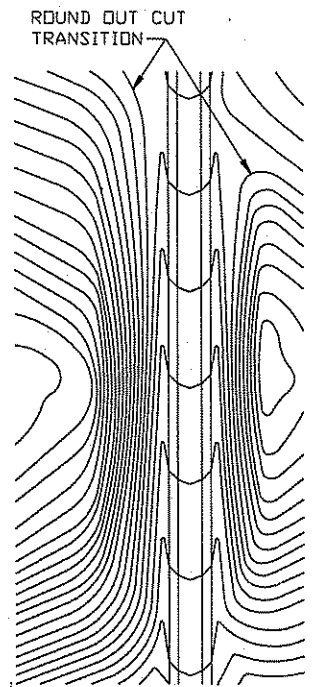

CONTOURING ROAD CUTS

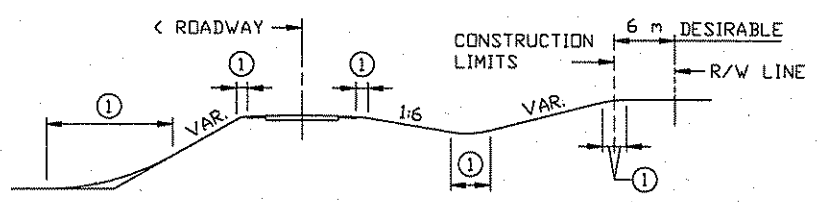

ROUNDING SHOULDERS AND BACKSLOPES

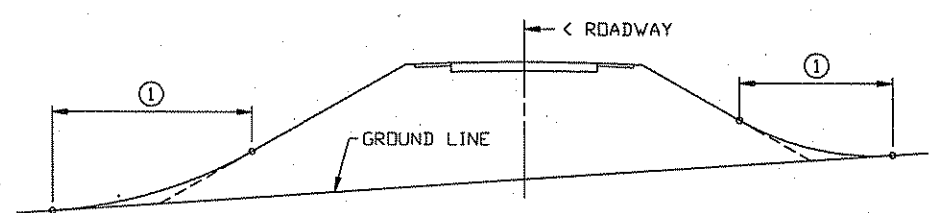

SHAPING FOR DRAINAGE ALONG THE TOE OF FILL SLOPES

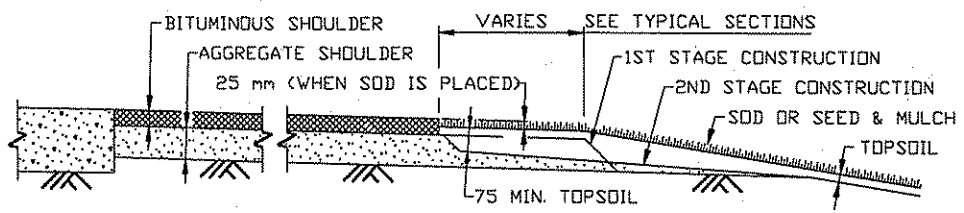

SHAPING AND TOPSOILING INSLOPES

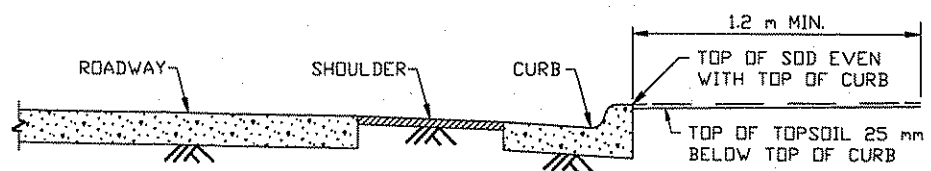

SHAPING ADJACENT TO CURBS WHEN SOD IS PLACED

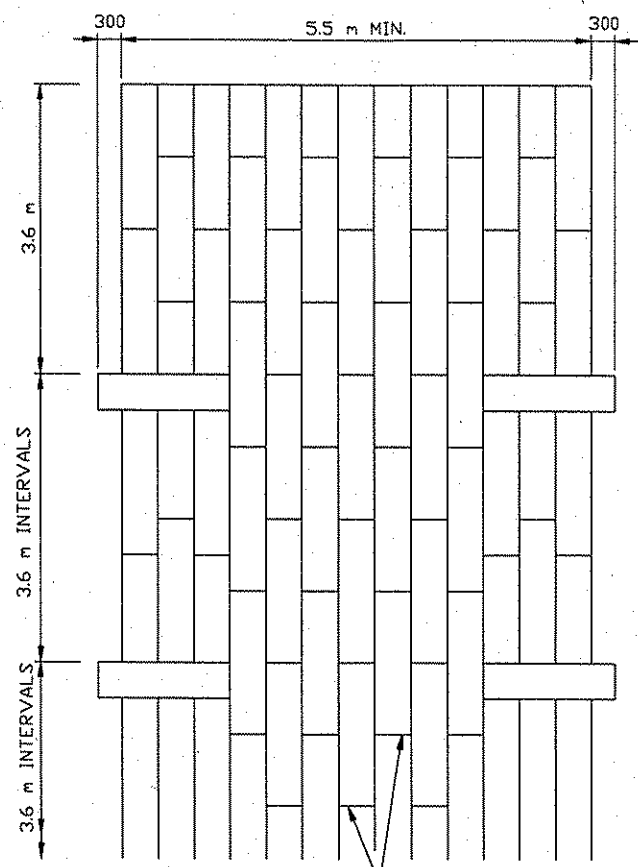

STAGGER JOINTS  
PLAN VIEW

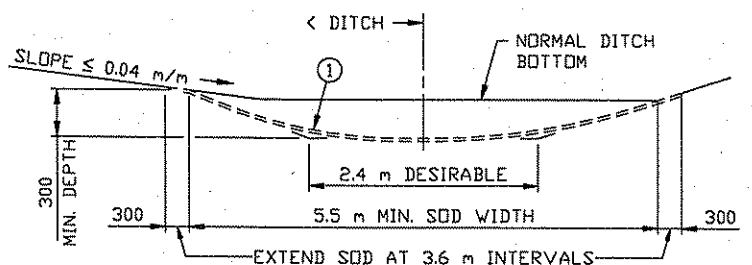

SODDED DITCH CROSS SECTION  
WHERE FRONT OR BACK SLOPE IS FLAT (LESS THAN 0.04 m/m), FIRST NOTCH DITCH AND THEN PROVIDE ROUNDING.

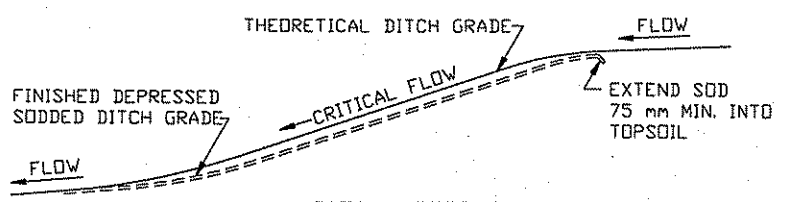

DITCH PROFILE  
SODDED DITCH DETAILS

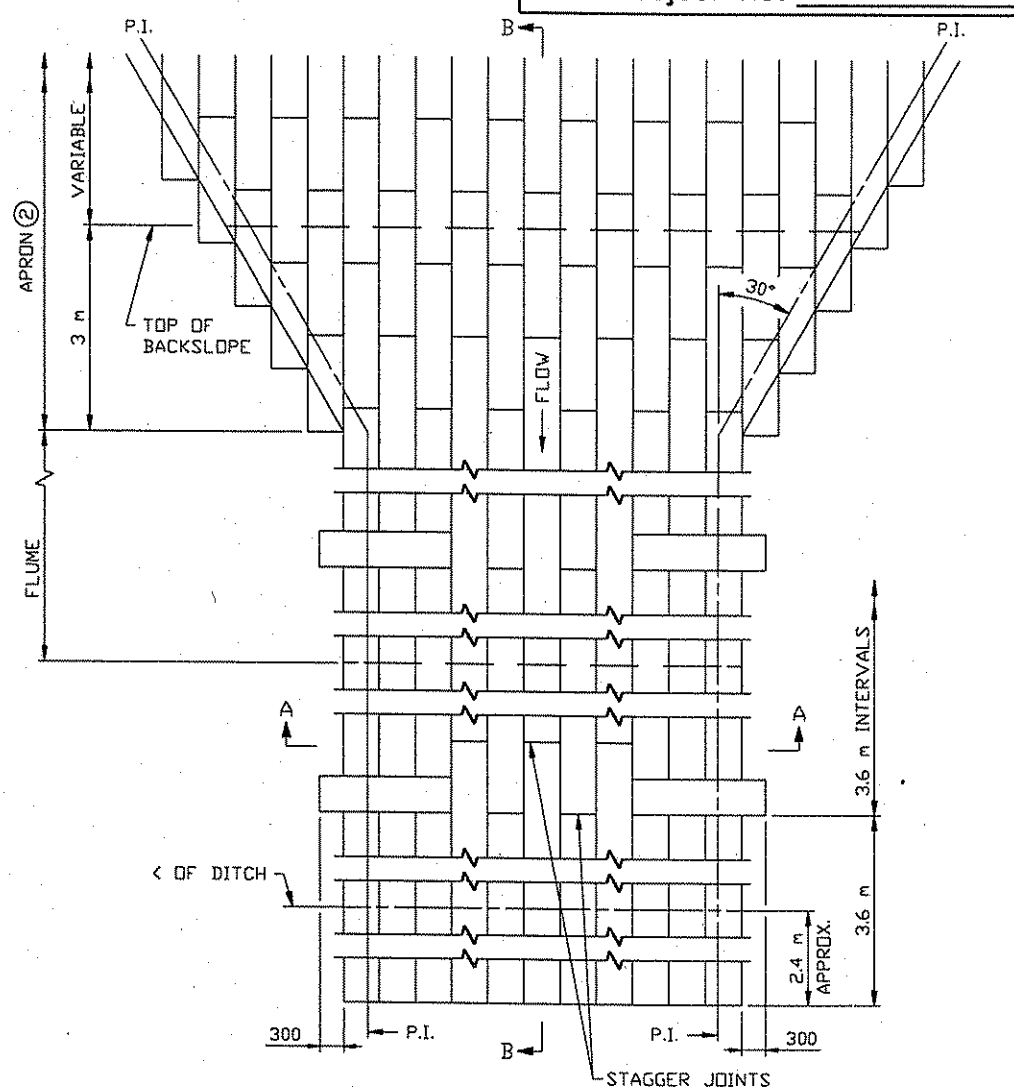

STAGGER JOINTS  
PLAN VIEW

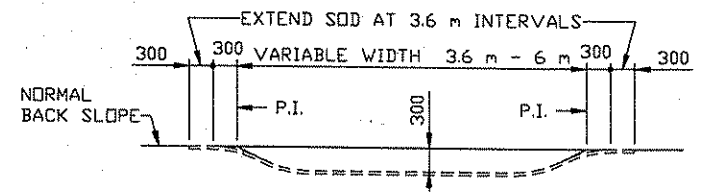

SECTION A-A

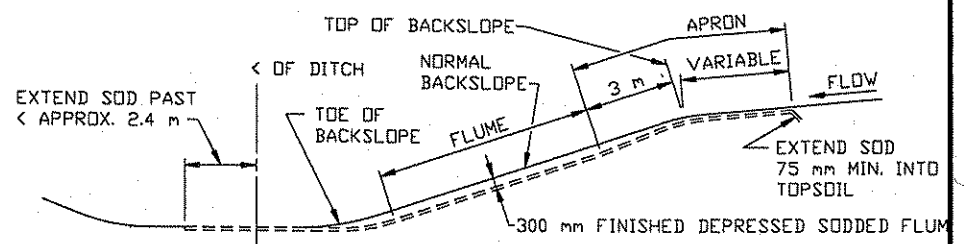

SECTION B-B  
SODDED FLUME DETAILS

- NOTES:  
SEE SPEC. 2575.3 FOR ADDITIONAL INFORMATION.  
① FOR ROUNDING, SEE ROAD DESIGN MANUAL.  
② CONSTRUCT TAPER AS DIRECTED BY THE ENGINEER.

NOTE: ALL DIMENSIONS ARE IN MILLIMETERS, EXCEPT AS NOTED.

STANDARD SHEET No. 5-297.404

NO	DATE	BY	CHKD	APPR	REVISION



I HEREBY CERTIFY THAT THIS PLAN WAS PREPARED BY ME OR UNDER MY DIRECT SUPERVISION AND THAT I AM A DULY REGISTERED PROFESSIONAL ENGINEER UNDER THE LAWS OF THE STATE OF MINNESOTA.  
*Allyson*  
DATE 07/09/99 REG. NO. 25066

DRAWN BY \_\_\_\_\_ DATE \_\_\_\_\_  
DESIGN BY \_\_\_\_\_ DATE \_\_\_\_\_  
CHECKED BY \_\_\_\_\_ DATE \_\_\_\_\_



ANOKA COUNTY  
HIGHWAY DEPT.

STATE PROJECT NO. 02-601-39  
STATE PROJECT NO. 02-678-14  
STATE PROJECT NO. 114-106-03  
STATE PROJECT NO. 114-020-21

PERMANENT EROSION CONTROL  
ALONG ROADWAYS, DITCHES AND FLUME  
Sheet 8 of 40 Sheets



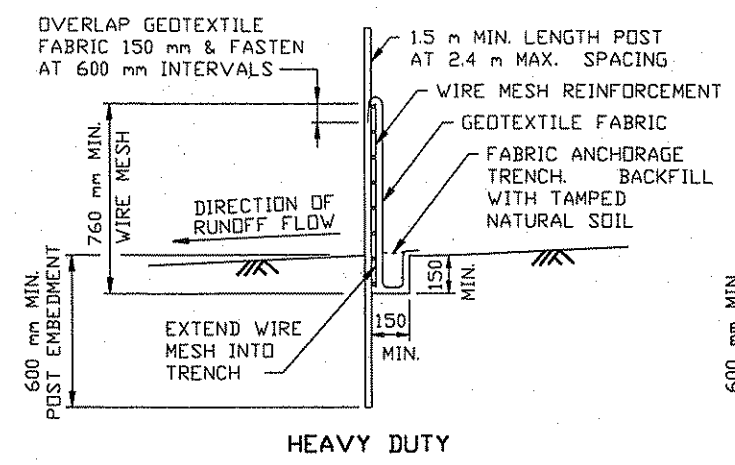

HEAVY DUTY

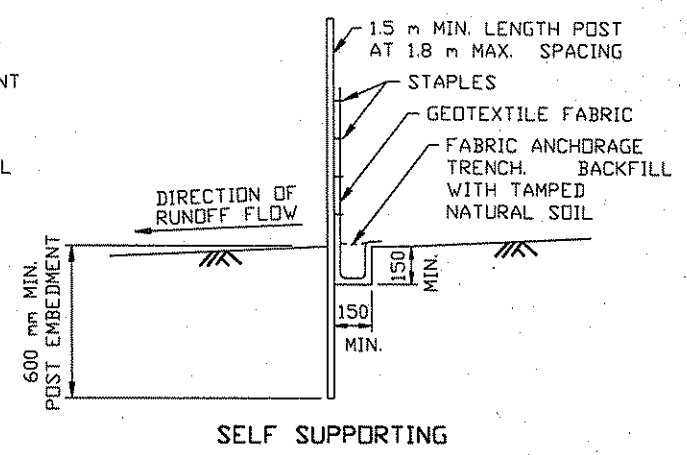

SELF SUPPORTING

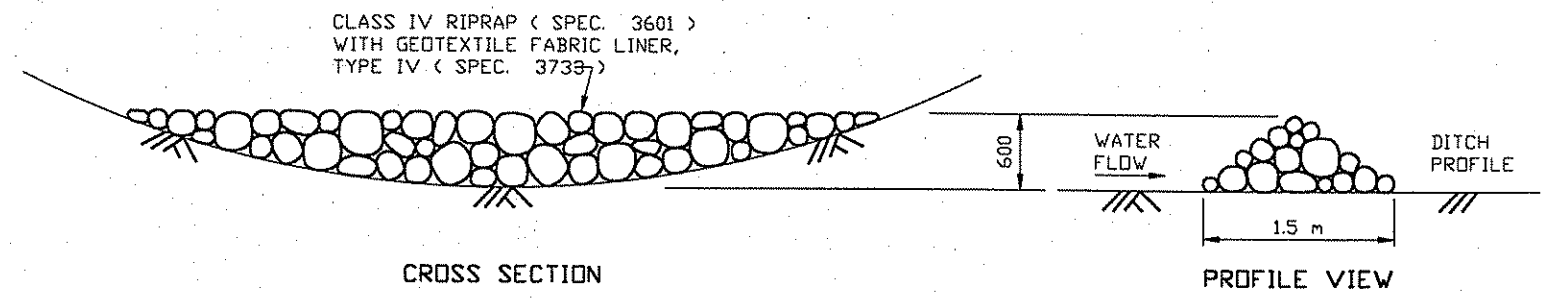

CROSS SECTION

PROFILE VIEW

ROCK DITCH CHECK

**SILT FENCE DETAILS**  
TO PROTECT AREAS FROM SHEET FLOW  
(SEE SPEC. 3886)

DESIGN CRITERIA:  
MAXIMUM CONTRIBUTING AREA: 1.2 ha

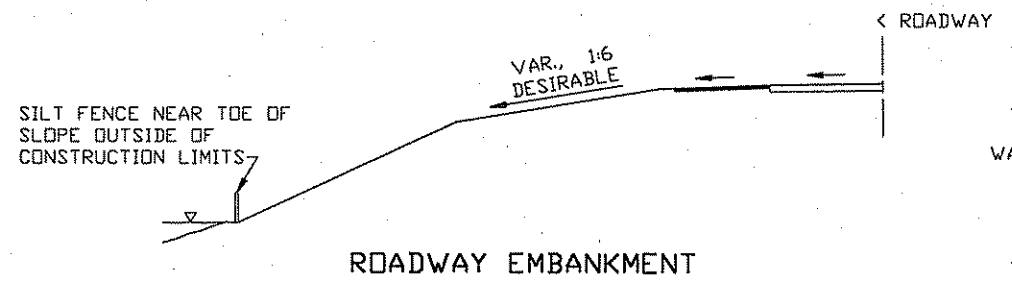

ROADWAY EMBANKMENT

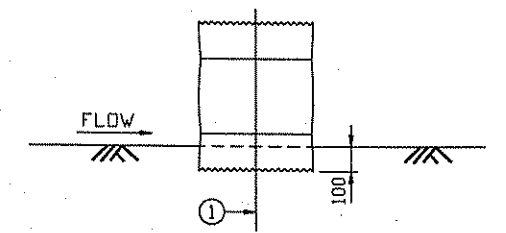

BALE CHECK DETAIL

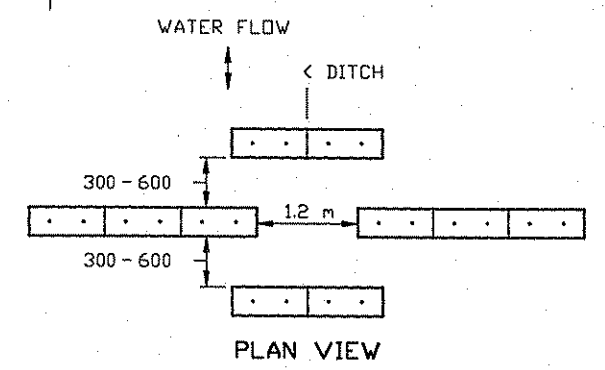

PLAN VIEW

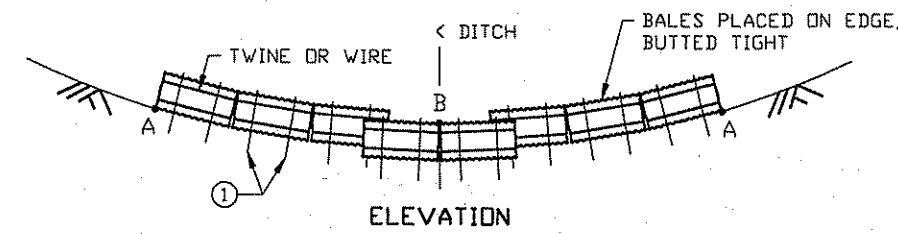

ELEVATION

NOTE:  
POINT A MUST BE HIGHER THAN POINT B

**BALE DITCH VELOCITY CHECKS**  
(WILL REQUIRE A MINIMUM OF 10 BALES PER SITE)

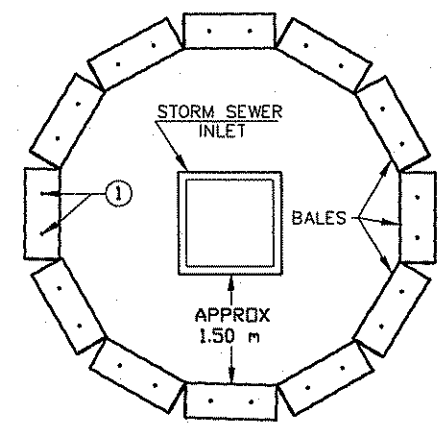

**BALE CHECK**  
TO PROTECT STORM SEWER INLETS

RECOMMENDED SPACING BETWEEN DITCH CHECKS	
DITCH GRADE (%)	SPACING (m)
2	30
4	23
6	15
8	12
10	8

DESIGN CRITERIA:

	BALE	ROCK
STORM FREQUENCY:	2 YR. - 24 HR.	10 YR. - 24 HR.
MAX. FLOW VELOCITY:	1.5 m/s	3.6 m/s
MAX. DITCH GRADE:	5%	—
MAX. DRAINAGE AREA:	0.8 ha	2.0 ha

NOTE:  
TWO 50 mm X 50 mm WOOD STAKES OR REINFORCING BARS IN EACH BALE AND EMBEDDED IN THE GROUND 250 mm MINIMUM.

NOTE: ALL DIMENSIONS ARE IN MILLIMETERS, EXCEPT AS NOTED.

NO	DATE	BY	CKD	APPR	REVISION



I HEREBY CERTIFY THAT THIS PLAN WAS PREPARED BY ME OR UNDER MY DIRECT SUPERVISION AND THAT I AM A DULY REGISTERED PROFESSIONAL ENGINEER UNDER THE LAWS OF THE STATE OF MINNESOTA.  
*Albert*  
DATE 04-07-95 REG. NO. 25066

DRAWN BY \_\_\_\_\_ DATE \_\_\_\_\_  
DESIGN BY \_\_\_\_\_ DATE \_\_\_\_\_  
CHECKED BY \_\_\_\_\_ DATE \_\_\_\_\_



ANOKA COUNTY  
HIGHWAY DEPT.

STATE PROJECT NO. 02-601-39  
STATE PROJECT NO. 02-678-14  
STATE PROJECT NO. 114-106-03  
STATE PROJECT NO. 114-020-21

TEMPORARY EROSION CONTROL  
Sheet 9 of 40 Sheets

**TYPICAL MAINLINE CSAH 78 CONSTRUCTION**

STA. 1+197.00 TO STA. 1+381.50

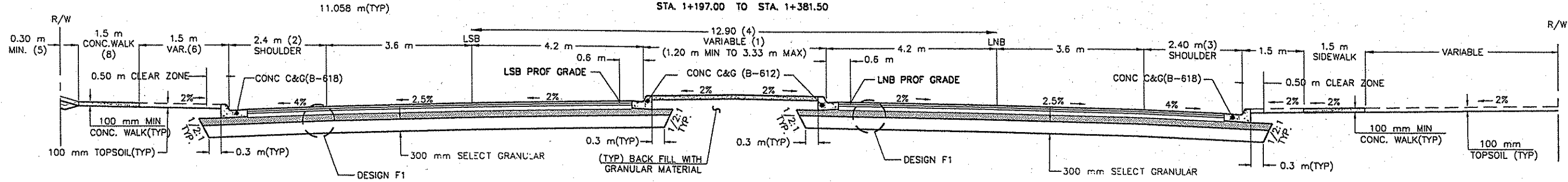

**TYPICAL DOUBLE TURN BAY CONSTRUCTION**

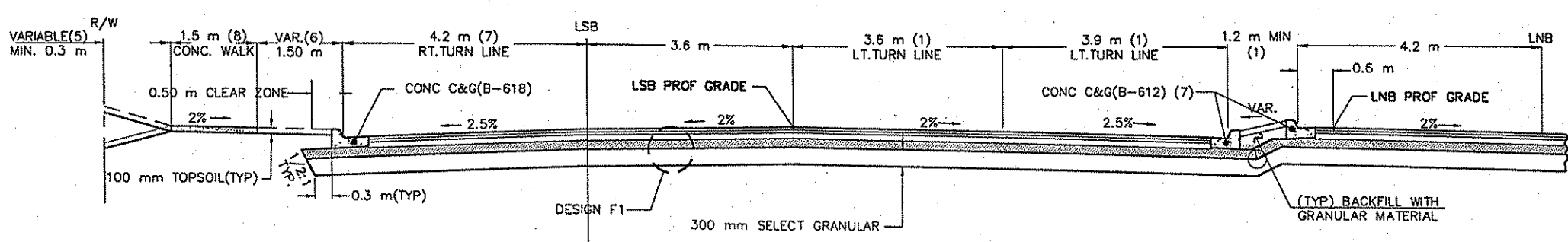

**TYPICAL FRONTAGE ROAD CONSTRUCTION**

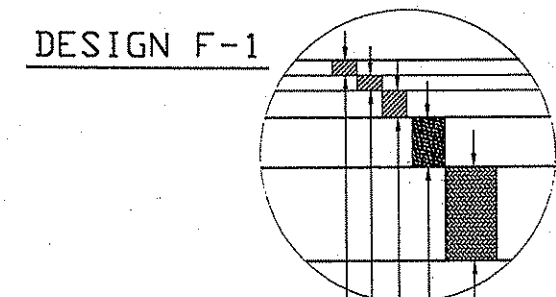
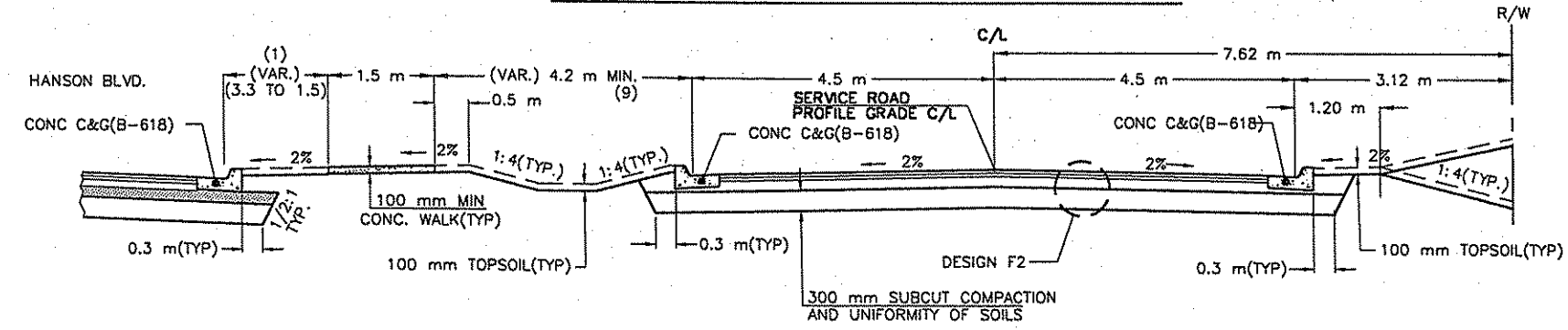

- (1) SEE PLAN AND PROFILE SHEET FOR LOCATION.
- (2) VARIABLE FROM 6.0 m TO 2.4 m  
STA. 1+321.65 TO 1+377.94
- (3) STA. 1+294.40 END 2.4 m SHOULDER.
- (4) 12.90 m, STA. 1+182.541 TO STA. 1+295.144.
- (5) STA. 1+273.50 END 0.30 m DIST. TO RW.
- (6) STA. 1+321.65 BEG 1.5 m BLVD.
- (7) STA. 1+321.65 END 4.20 m
- (8) STA. 1+321.65 END CONST. CONC WALK AND MATCH TO INPLACE.
- (9) SEE PLAN & PROFILE & X-SECTION SHEET FOR LOCATION.

**DESIGN F-3**  
TEMPORARY CONSTRUCTION

50 mm TYPE MVWE45035C  
150 mm AGGREGATE BASE CLASS 5

**DESIGN F-2**  
FRONTAGE ROAD

50 mm TYPE MVWE45035C  
50 mm TYPE MVNW35035C  
150 mm AGGREGATE BASE CLASS 5

50 mm TYPE MVWE45035C  
50 mm TYPE MVNW35035C  
80 mm TYPE LVNW35035B  
200 mm AGGREGATE BASE CLASS 5  
300 mm SELECT GRANULAR 3149.2B2

NO	DATE	BY	CKD	APPR	REVISION



I HEREBY CERTIFY THAT THIS PLAN WAS PREPARED BY ME OR UNDER MY DIRECT SUPERVISION AND THAT I AM A DULY REGISTERED PROFESSIONAL ENGINEER UNDER THE LAWS OF THE STATE OF MINNESOTA.

*Allyson*

DATE 07-09-99 REG. NO. 25066

DRAWN BY: \_\_\_\_\_ DATE 02-09-99  
DESIGN BY: \_\_\_\_\_ DATE 02-09-99  
CHECKED BY: \_\_\_\_\_ DATE \_\_\_\_\_



**ANOKA COUNTY**  
**HIGHWAY DEPT.**

STATE PROJECT NO. 02-601-39  
STATE PROJECT NO. 02-678-14  
STATE PROJECT NO. 114-106-03  
STATE PROJECT NO. 114-020-21

**TYPICAL SECTIONS**  
Sheet 10 of 40 Sheets

**PARTIAL WIDTH RECONSTRUCTION WITH ISLAND (HANSON BLVD NW)**

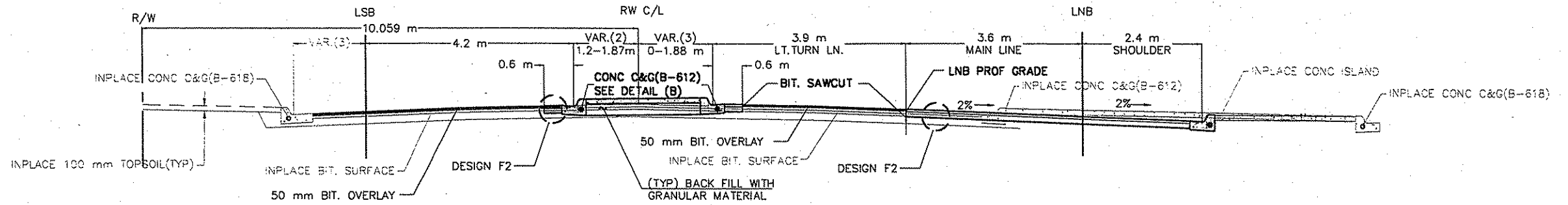

**PARTIAL RECONSTRUCTION WITH ISLAND (HANSON BLVD NW)**

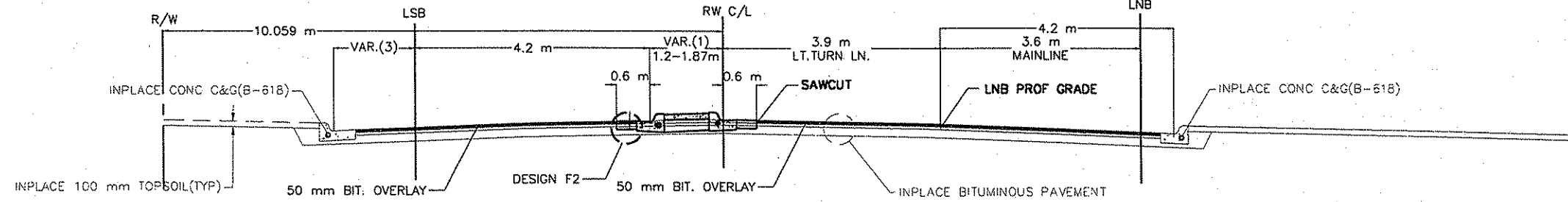

**TEMPORARY PARTIAL WIDTH CONSTRUCTION (CSAH 78)**

STA. 1+396.600 TO STA. 1+489.000

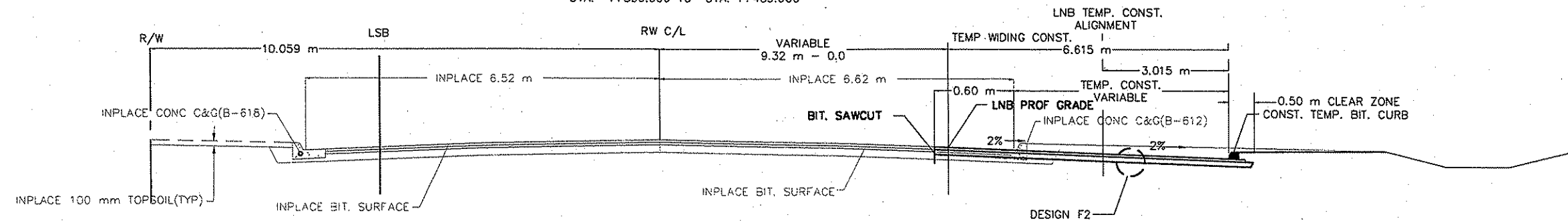

**DETAIL "A"**

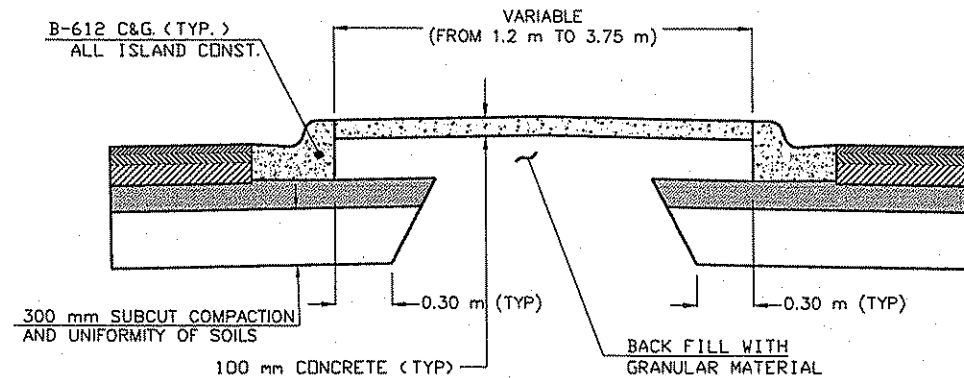

**DETAIL "B"**

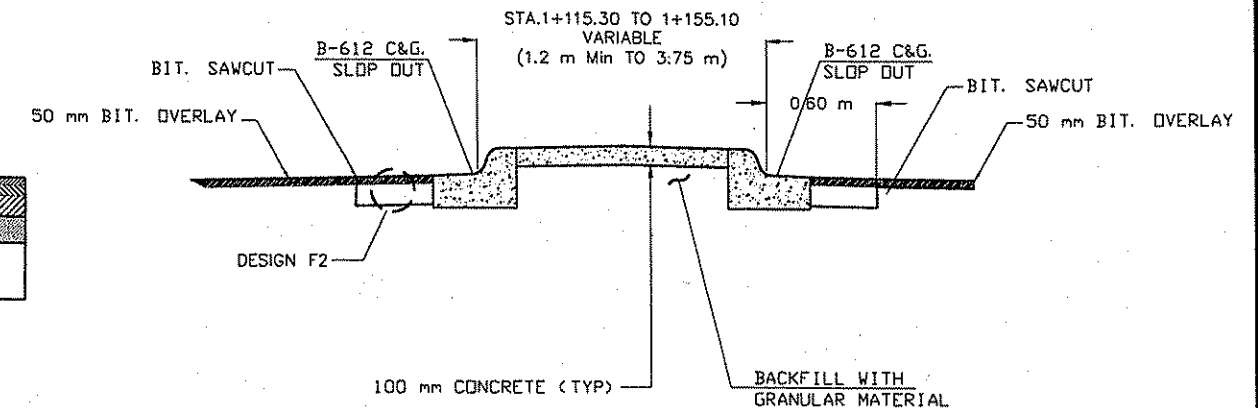

- 1- STA. 1+116.40, to 1+144.63, (1.20 m-3.19 m WIDTH)
- 2- STA. 1+116.40, 1.2 m FROM C/L (FACE OF CURB TO FACE OF CURB)
- 3- VARIABLE FROM R/W CL (0.0 m TO 1.88)

NO	DATE	BY	CKD	APPR	REVISION



I HEREBY CERTIFY THAT THIS PLAN WAS PREPARED BY ME OR UNDER MY DIRECT SUPERVISION AND THAT I AM A DULY REGISTERED PROFESSIONAL ENGINEER UNDER THE LAWS OF THE STATE OF MINNESOTA.

*Albert*

DATE 07-09-99 REG. NO. 25066

DRAWN BY: MW DATE 07-09-99  
 DESIGN BY: MW DATE 07-09-99  
 CHECKED BY: \_\_\_\_\_ DATE \_\_\_\_\_

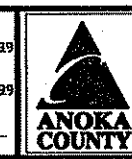

**ANOKA COUNTY  
 HIGHWAY DEPT.**

STATE PROJECT NO. 02-601-39  
 STATE PROJECT NO. 02-678-14  
 STATE PROJECT NO. 114-106-03  
 STATE PROJECT NO. 114-020-21

**TYPICAL SECTIONS**

Sheet 11 of 40 Sheets

**CROSS GUTTER DETAIL**  
 STA. 1+077.80 TO 1+099.30 LT. LSB

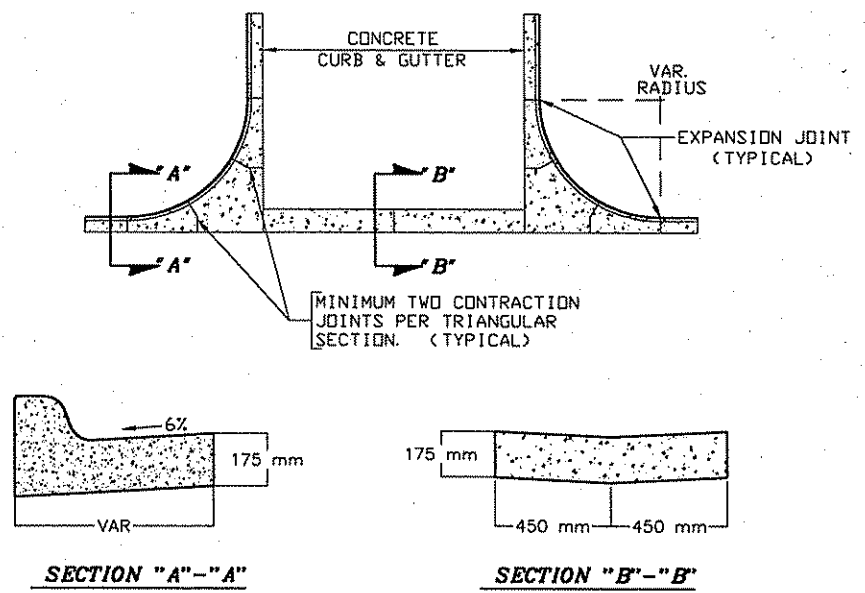

NOTE: CURB IN RADIUS SHALL BE FORMED AND POURED AS ONE UNIT, WITH THE CROSS GUTTER TO BE CONSIDERED PART OF THE TRIANGULAR SECTION FOR PAYMENT PURPOSES.

CONSTRUCT CROSS GUTTER SAME THICKNESS AS B-618 CURB & GUTTER.

CONSTRUCT ONE SIDE AT A TIME TO PROVIDE FOR TRAFFIC.

NO	DATE	BY	CKD	APPR	REVISION
12-Lateral.dwg	62999	11818			



I HEREBY CERTIFY THAT THIS PLAN WAS PREPARED BY ME OR UNDER MY DIRECT SUPERVISION AND THAT I AM A DULY REGISTERED PROFESSIONAL ENGINEER UNDER THE LAWS OF THE STATE OF MINNESOTA.

*Albert*

DATE 07/09/99 REG. NO. 25066

DRAWN BY \_\_\_\_\_ DATE \_\_\_\_\_  
 DESIGN BY \_\_\_\_\_ DATE \_\_\_\_\_  
 CHECKED BY \_\_\_\_\_ DATE \_\_\_\_\_



**ANOKA COUNTY**  
**HIGHWAY DEPT.**

STATE PROJECT NO. 02-601-39  
 STATE PROJECT NO. 02-678-14  
 STATE PROJECT NO. 114-106-03  
 STATE PROJECT NO. 114-020-21

**SPECIAL DETAILS**

Sheet 12 of 40 Sheets

ALIGNMENT TABULATION

CURVE NO.	POINT NO.	POINT TYPE	LOCATION	CURVE DATA				COORDINATES			
				COURSE	DELTA	RADIUS(m)	TANGENT(m)	LENGTH(m)	NORTHING	EASTING	AZIMUTH
R/W CENTERLINE ALIGNMENT											
	1	PI	STA. 0+000.000	N00°47'02"E				684.778	44183.6271	148363.5033	000°47'02"
	2	PI	STA. 1+584.778	N00°47'02"E					44848.3405	148372.8723	000°47'02"
LNB ALIGNMENT											
	11	PI	STA. 1+000.011	N02°00'03"E					44263.5685	148368.4712	000°47'02"
	12	PI	STA. 1+078.548	N03°48'49"E					44297.2533	148368.9321	003°48'49"
	13	PI	STA. 1+182.468	N01°58'18"W					44445.7254	148378.4151	
	14	PC	STA. 1+295.089						44558.2616	148382.2894	
1-N	15	PI	STA. 1+321.252	N00°01'42"W	02°00'00"	1500.000	26.1830	52.380	44584.4287	148383.1903	359°58'18"
	16	PT	STA. 1+347.429						44610.6113	148383.1774	
	17	PI	STA. 1+443.147	N00°47'02"E	00°48'44"				44708.3294	148383.1303	000°47'02"
	18	PI	STA. 1+998.547						45259.6773	148390.7018	
LNB TEMP. CONSTRUCTION ALIGNMENT											
	11	PI	STA. 1+000.011	N02°00'03"E					44263.5685	148368.4712	
	12	PI	STA. 1+078.548	N03°58'26"E					44342.0572	148371.2139	
	13	PI	STA. 1+182.468	N01°58'18"W					44445.7254	148378.4151	
	14	PC	STA. 1+295.089						44558.2616	148382.2894	
1-TM	15	PI	STA. 1+321.251	N00°01'42"W	02°00'00"	1500.000	26.1830	52.380	44584.4287	148383.1903	
	16	PT	STA. 1+347.428						44610.6113	148383.1774	
	17A	PC	STA. 1+392.233						44655.4154	148383.1554	
2-TM	18A	PI	STA. 1+415.534	N10°54'45"W	09°51'53"	270.000	23.301	46.487	44678.7184	148383.1439	
	19A	PT	STA. 1+438.719						44701.8709	148379.1406	
	20A	PC	STA. 1+438.719						44701.8709	148379.1406	
3-TM	21A	PI	STA. 1+483.949	N10°54'45"W	10°40'37"	270.000	25.230	60.314	44726.5257	148374.8058	
	22A	PT	STA. 1+489.033						44751.7534	148375.1510	
	23A	PI	STA. 1+585.580	N00°47'02"E					44848.2913	148376.4719	
LSB ALIGNMENT											
	41	PI	STA. 1+000.000	N00°47'02"E					44263.6870	148361.2718	000°47'02"
	42	PI	STA. 1+033.744	N00°27'37"W	01°14'39"				44297.4079	148361.7335	359°32'23"
	43	PC	STA. 1+139.348						44403.0088	148360.8853	
1-S	44	PI	STA. 1+149.982	N01°58'18"E	02°25'55"	500.000	10.813	21.223	44413.8217	148360.8000	001°58'18"
	45	PT	STA. 1+160.572						44424.2288	148361.1652	
	46	PC	STA. 1+401.207						44684.7214	148369.4448	
2-S	47	PI	STA. 1+411.573	N00°47'02"E	01°11'16"	1000.000	10.366	20.732	44675.0816	148369.8015	000°47'02"
	48	PT	STA. 1+421.939						44685.4470	148369.9433	
	49	PI	STA. 1+998.399						45259.8538	148377.8030	
TEMPORARY LNB-CONTROL PROFILE ALIGNMENT (3.6 m LT. LNB TEMP. CONSTRUCT. ALIGNMENT)											
	32	PI	STA. 1+000.011	N02°00'03"E					44263.6842	148364.8734	002°00'03"
	33	PI	STA. 1+078.810	N03°58'26"E	01°58'23"				44342.2449	148367.8177	003°58'26"
	34	PI	STA. 1+182.527	N01°58'18"E	02°00'08"				44445.9122	148374.8194	001°58'18"
	36	PC	STA. 1+295.086						44558.3845	148378.8915	001°58'18"
1-NT	37	PI	STA. 1+321.187	N00°01'42"W	02°00'00"	1495.400	26.121	52.236	44584.4898	148379.5903	359°58'18"
	38	PT	STA. 1+347.302						44610.6105	148379.5774	
	39	PI	STA. 1+347.302	N00°01'42"E	00°00'00"				44610.6105	148379.5774	000°01'42"
	40	PC	STA. 1+392.105						44655.4136	148379.5554	
2-NT	41	PI	STA. 1+415.095	N10°54'45"W	09°51'53"	288.400	22.990	45.887	44678.4039	148379.5440	349°05'15"
	42	PT	STA. 1+437.972						44701.0524	148375.5941	
	43	PC	STA. 1+437.972						44701.0524	148375.5941	
3-NT	44	PI	STA. 1+483.538	N00°47'02"E	10°40'37"	273.600	25.566	50.985	44726.2388	148371.2018	000°47'02"
	45	PT	STA. 1+488.957						44751.8026	148371.5514	
	46	PI	STA. 1+585.504						44848.3405	148372.8723	
NEW SERVICE ROAD C/L											
	81	PI	STA. 1+000.000	N88°05'26"W					44525.8008	148467.8373	271°54'34"
	82	PC	STA. 1+049.395						44527.4487	148418.2695	
1-SR	83	PI	STA. 1+088.914	N01°58'18"E	90°03'44"	17.500	17.519	27.508	44528.0305	148400.7602	001°58'18"
	84	PT	STA. 1+078.903						44545.5391	148401.3830	
	85	PI	STA. 1+088.962						44557.5907	148401.7779	
	86	PI	STA. 1+108.117	N01°19'30"E	00°19'24"				44574.7382	148402.2714	001°19'30"
	87	PC	STA. 1+108.117						44574.7382	148402.2714	
2-SR	88	PI	STA. 1+128.483	N32°45'07"E	31°25'38"	79.500	22.387	43.808	44597.0990	148402.7885	032°45'07"
	89	PT	STA. 1+149.723						44615.9099	148414.8890	
	90	PC	STA. 1+149.723						44615.9099	148414.8890	
3-SR	91	PI	STA. 1+159.870	N00°01'42"W	32°46'49"	34.500	10.147	19.738	44624.4441	148420.3788	359°58'18"
	92	PT	STA. 1+169.481						44634.5915	148420.3739	
	93	PC	STA. 1+172.803						44637.9333	148420.3722	
4-SR	94	PI	STA. 1+190.303	S89°58'18"W	90°00'00"	17.500	17.500	27.489	44655.4333	148420.3636	269°58'18"
	95	PT	STA. 1+200.292						44655.4247	148402.8636	
	96	PI	STA. 1+220.000						44655.4150	148383.1554	

NO.	DATE	BY	CKD	APPR	REVISION
NAME:	15-aligntab.dwg	6-29-99	1:13:23	pm	EST



I HEREBY CERTIFY THAT THIS PLAN WAS PREPARED BY ME OR UNDER MY DIRECT SUPERVISION AND THAT I AM A DULY REGISTERED PROFESSIONAL ENGINEER UNDER THE LAWS OF THE STATE OF MINNESOTA.

*[Signature]*

DATE 07/09/99 REG. NO. 25066

DRAWN BY \_\_\_\_\_ DATE \_\_\_\_\_

DESIGN BY \_\_\_\_\_ DATE \_\_\_\_\_

CHECKED BY \_\_\_\_\_ DATE \_\_\_\_\_



ANOKA COUNTY  
HIGHWAY DEPT.

STATE PROJECT NO. 02-601-39  
STATE PROJECT NO. 02-678-14  
STATE PROJECT NO. 114-106-03  
STATE PROJECT NO. 114-020-21

ALIGNMENT TABULATION  
Sheet 13 of 40 Sheets

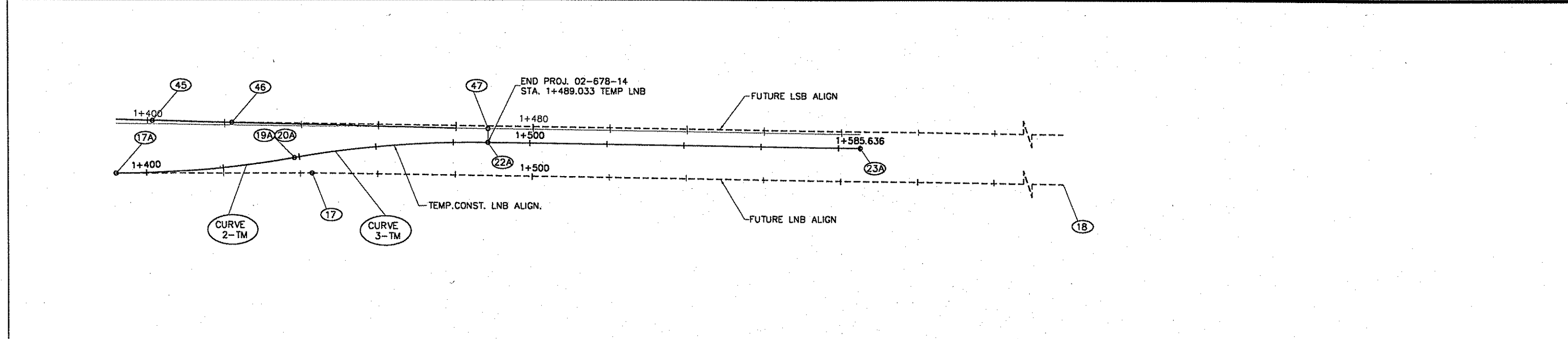
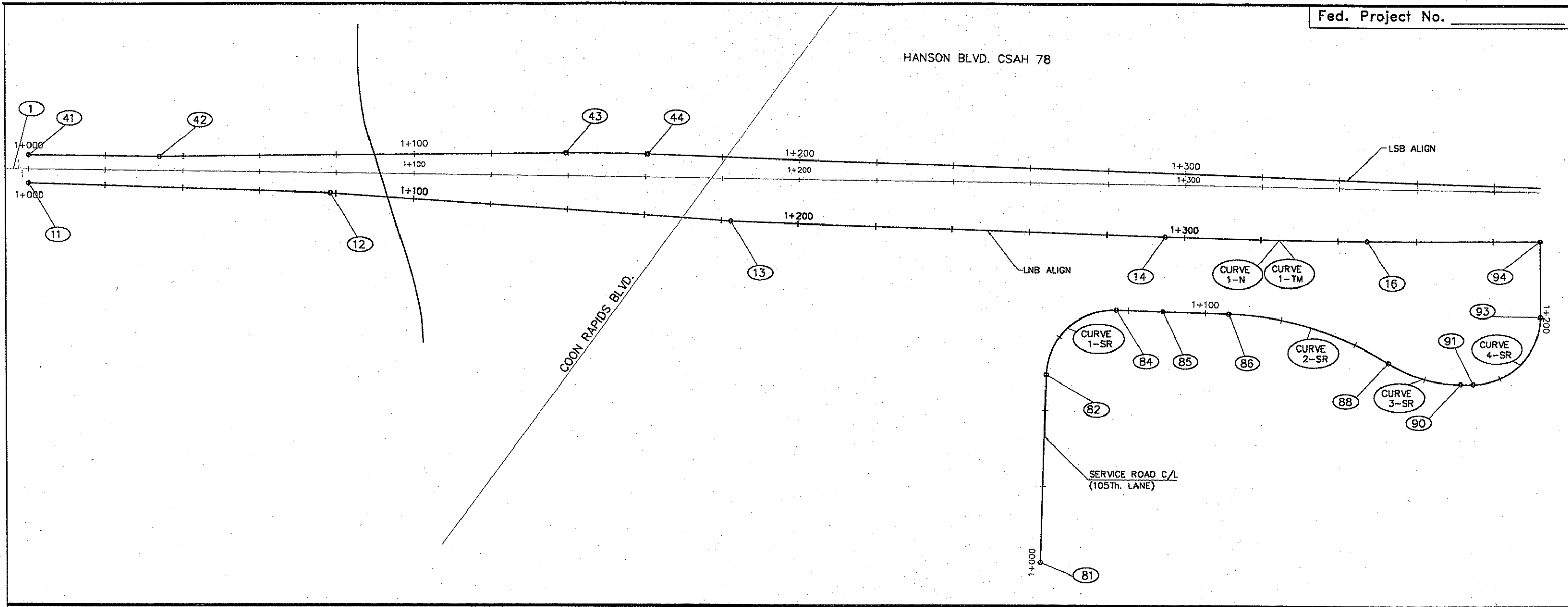

NO	DATE	BY	CHKD	APPR	REVISION



I HEREBY CERTIFY THAT THIS PLAN WAS PREPARED BY ME OR UNDER MY DIRECT SUPERVISION AND THAT I AM A DULY REGISTERED PROFESSIONAL ENGINEER UNDER THE LAWS OF THE STATE OF MINNESOTA.

*Allyson*

DATE 07/09/99 REG. NO. 25066

DRAWN BY \_\_\_\_\_ DATE \_\_\_\_\_  
 DESIGN BY \_\_\_\_\_ DATE \_\_\_\_\_  
 CHECKED BY \_\_\_\_\_ DATE \_\_\_\_\_



ANOKA COUNTY  
 HIGHWAY DEPT.

STATE PROJECT NO. 02-601-39  
 STATE PROJECT NO. 02-678-14  
 STATE PROJECT NO. 114-106-03  
 STATE PROJECT NO. 114-020-21

ALIGNMENT PLAN  
 Sheet 14 of 40 Sheets

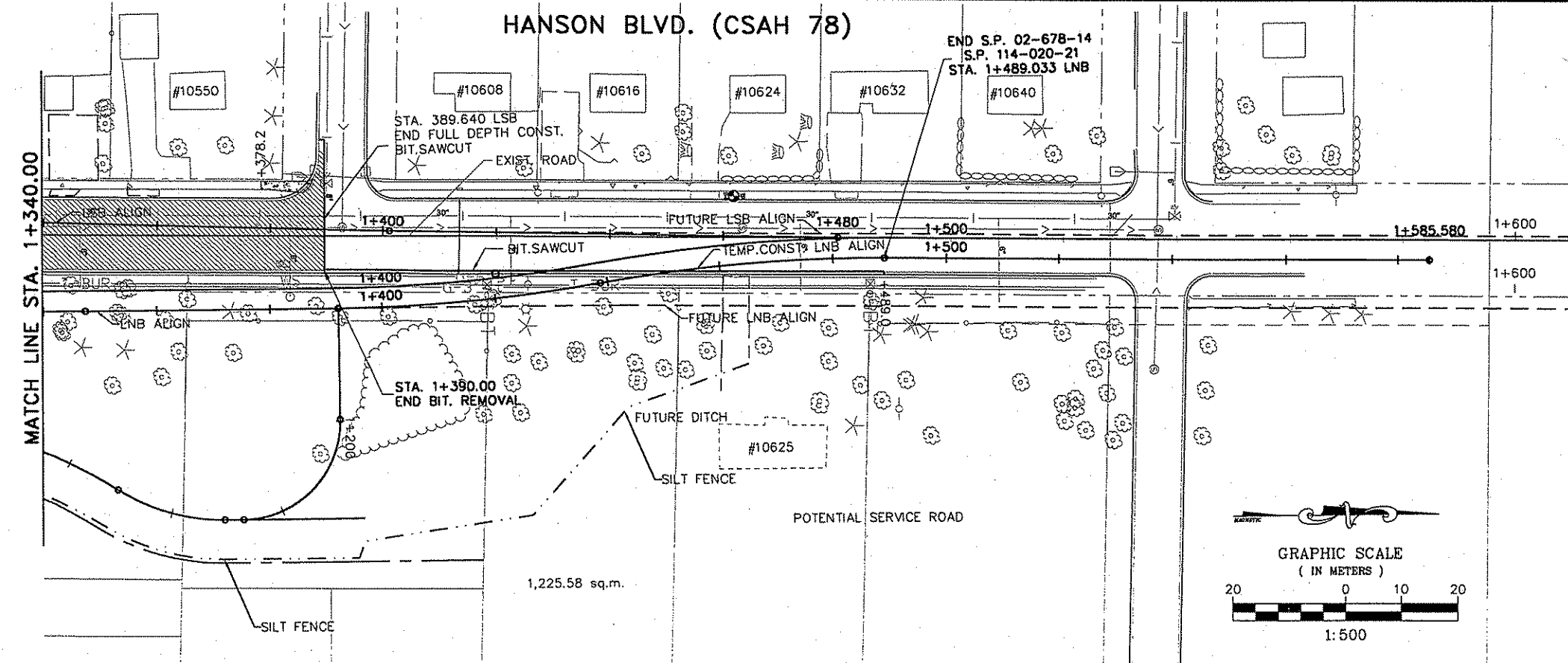
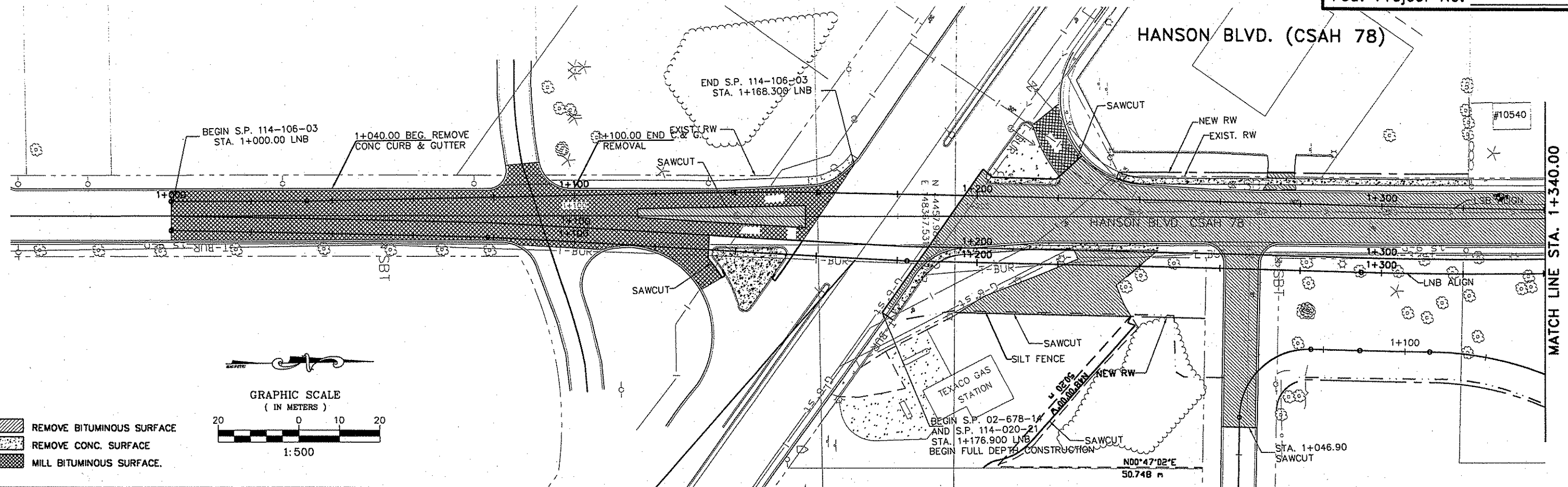

REMOVE BITUMINOUS SURFACE

NO	DATE	BY	CKD	APPR	REVISION
1	09-20-99	MIN			

NAME: MN 15-Exlst.dwg 9-20-99 11:47:25 am EST



I HEREBY CERTIFY THAT THIS PLAN WAS PREPARED BY ME OR UNDER MY DIRECT SUPERVISION AND THAT I AM A DULY REGISTERED PROFESSIONAL ENGINEER UNDER THE LAWS OF THE STATE OF MINNESOTA.

*Albert*

DATE 07/09/99 REG. NO. 25066

DRAWN BY: MN DATE 09-20-99  
 DESIGN BY: MN DATE 09-20-99  
 CHECKED BY: LAR DATE 09-20-99

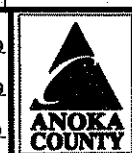

ANOKA COUNTY  
 HIGHWAY DEPT.

STATE PROJECT NO. 02-601-39  
 STATE PROJECT NO. 02-678-14  
 STATE PROJECT NO. 114-106-03  
 STATE PROJECT NO. 114-020-21

EXISTING CONDITION  
 AND REMOVALS  
 STA 1+000.00 TO 1+600.00  
 Sheet 15 of 40 Sheets

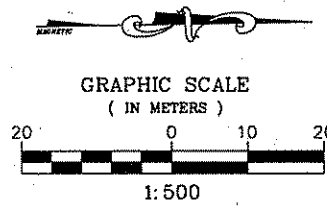
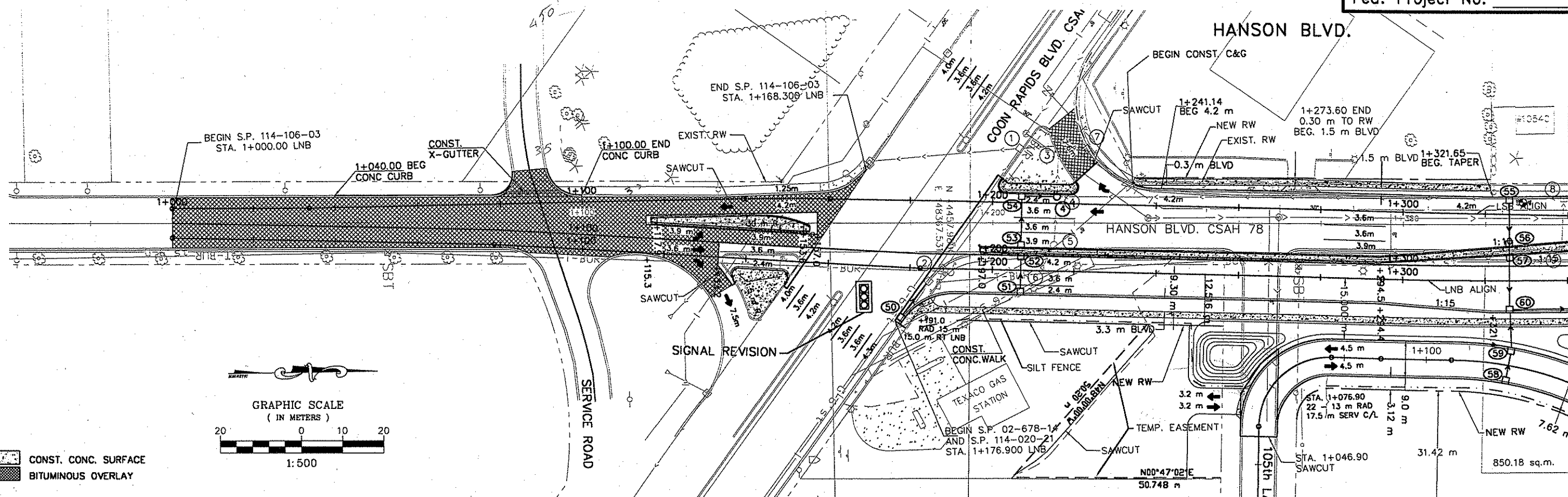

CONST. CONC. SURFACE  
BITUMINOUS OVERLAY

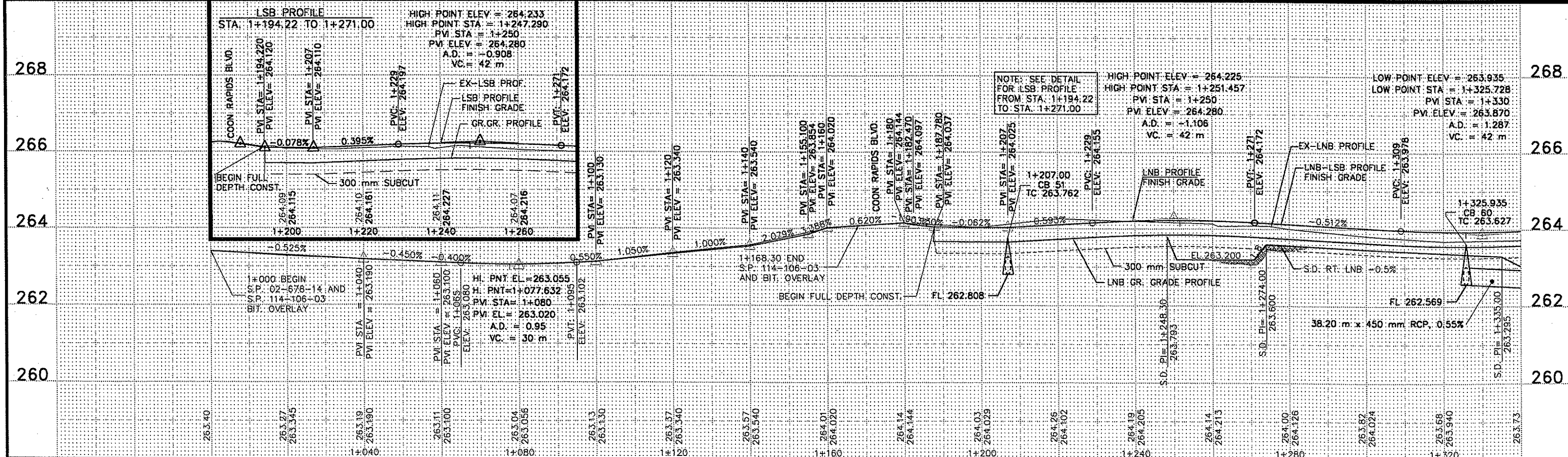

NO	DATE	BY	CKD	APPR	REVISION



I HEREBY CERTIFY THAT THIS PLAN WAS PREPARED BY ME OR UNDER MY DIRECT SUPERVISION AND THAT I AM A DULY REGISTERED PROFESSIONAL ENGINEER UNDER THE LAWS OF THE STATE OF MINNESOTA.

*Allyson*

DATE 07-09-99 REG. NO. 25065

DRAWN BY MN DATE 09-20-99  
 DESIGN BY MN DATE 09-20-99  
 CHECKED BY LAR DATE 09-20-99

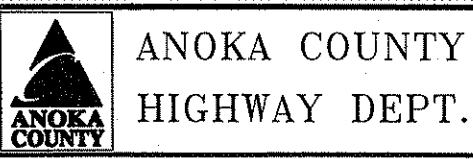

STATE PROJECT NO. 02-601-39  
 STATE PROJECT NO. 02-678-14  
 STATE PROJECT NO. 114-106-03  
 STATE PROJECT NO. 114-020-21

PLAN AND PROFILE  
 STA 1+000.00 TO 1+340.00  
 Sheet 16 of 40 Sheets



7911310

HANSON BLVD.

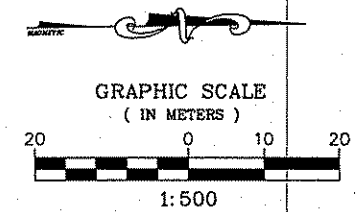
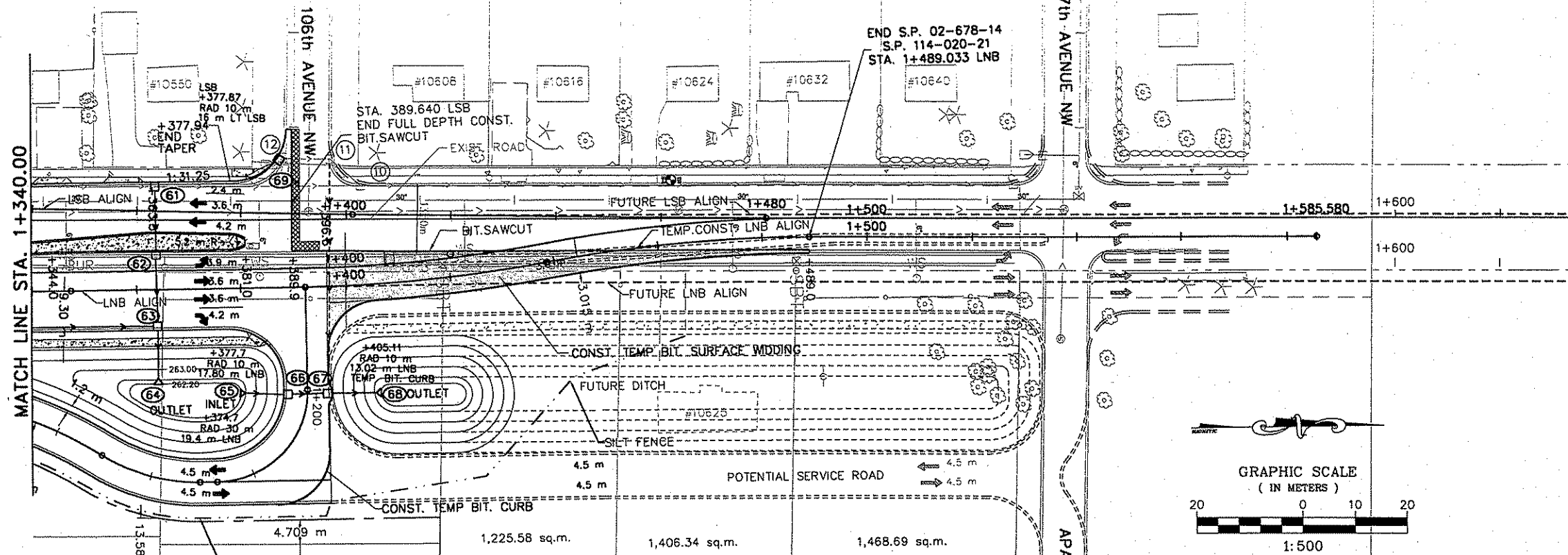

- CONST. TEMPORARY BIT. SURFACE.
- CONST. CONC. SURFACE
- OVERLAY MATCH TO EXISTING PAVEMENT

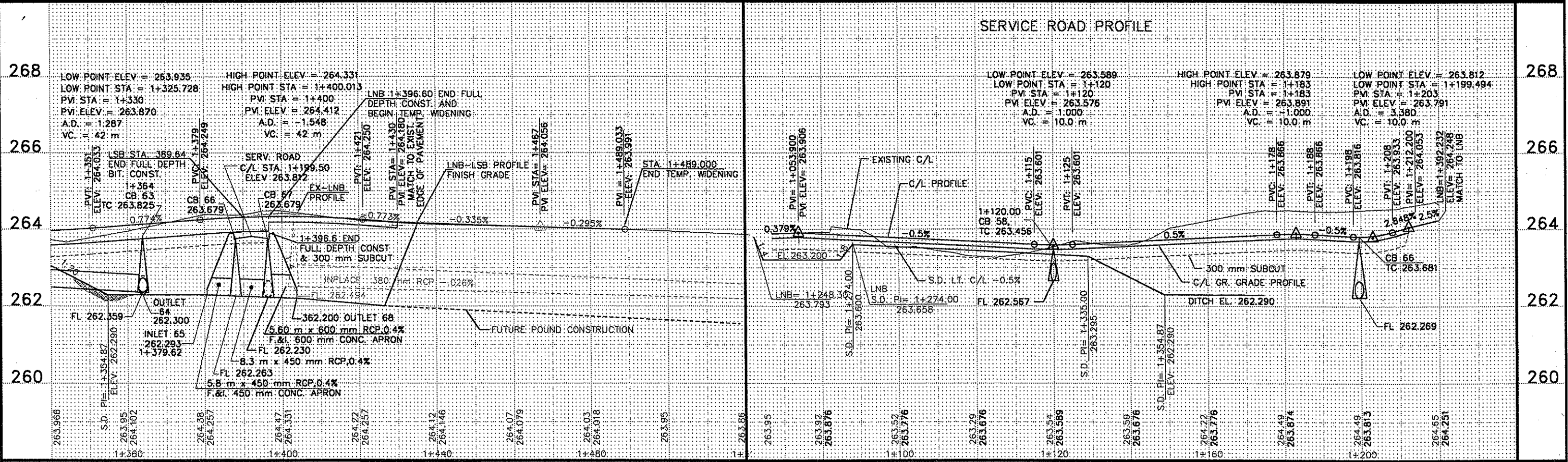

NO	DATE	BY	CKD	APPR	REVISION



I HEREBY CERTIFY THAT THIS PLAN WAS PREPARED BY ME OR UNDER MY DIRECT SUPERVISION AND THAT I AM A DULY REGISTERED PROFESSIONAL ENGINEER UNDER THE LAWS OF THE STATE OF MINNESOTA.

*Allyson*

DATE 07-09-99 REG. NO. 25066

DRAWN BY: MN DATE 20-20-99  
 DESIGN BY: MN DATE 09-20-99  
 CHECKED BY: LAR DATE 08-20-99

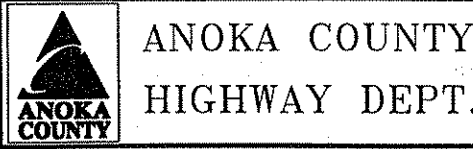

ANOKA COUNTY HIGHWAY DEPT.

STATE PROJECT NO. 02-601-39  
 STATE PROJECT NO. 02-678-14  
 STATE PROJECT NO. 114-106-03  
 STATE PROJECT NO. 114-020-21

PLAN AND PROFILE  
 STA 1+340.00 TO 1+489.00  
 Sheet 17 of 40 Sheets

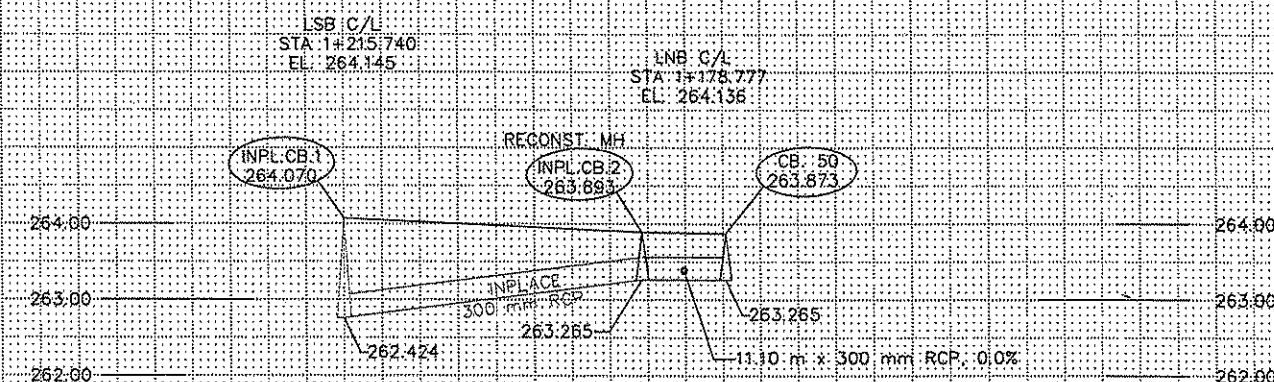
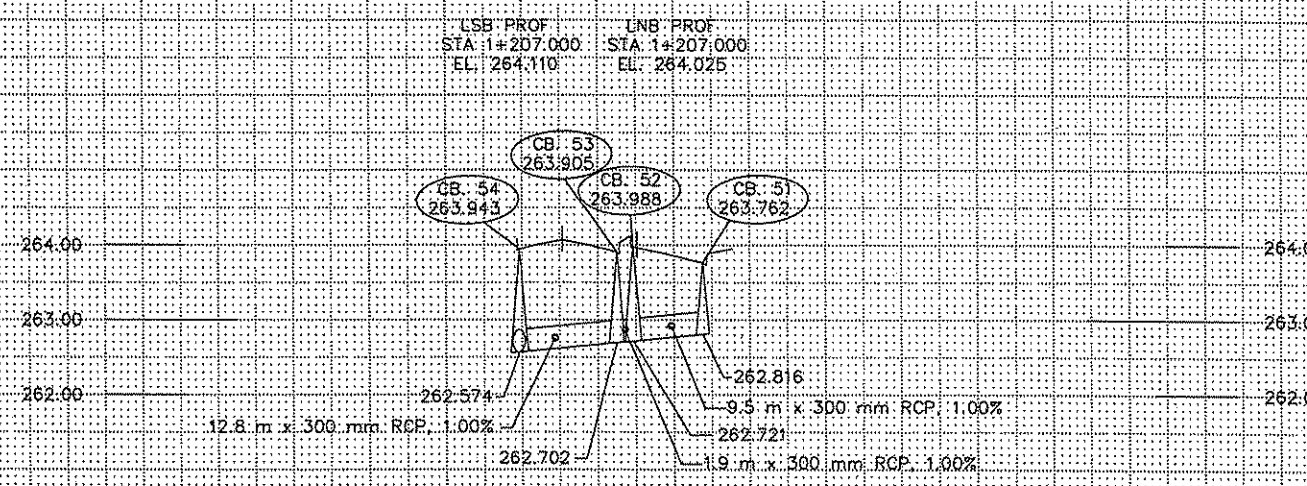
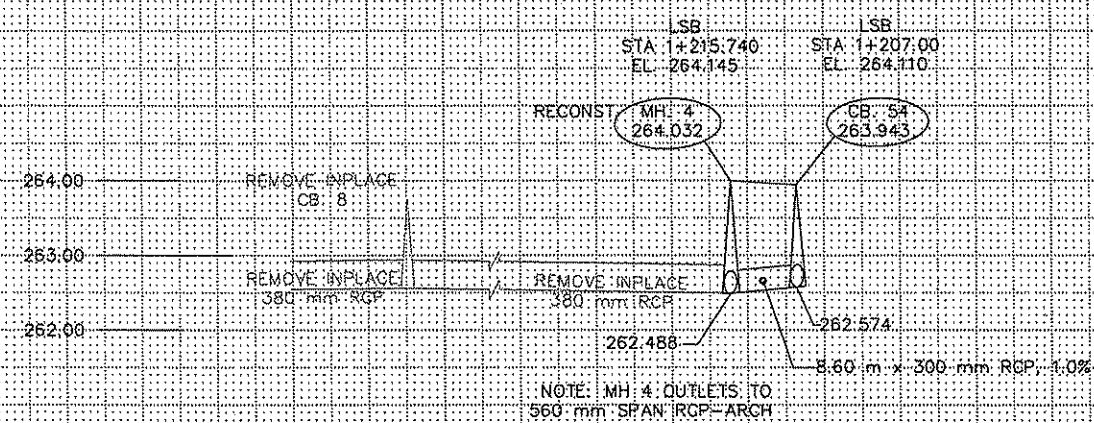
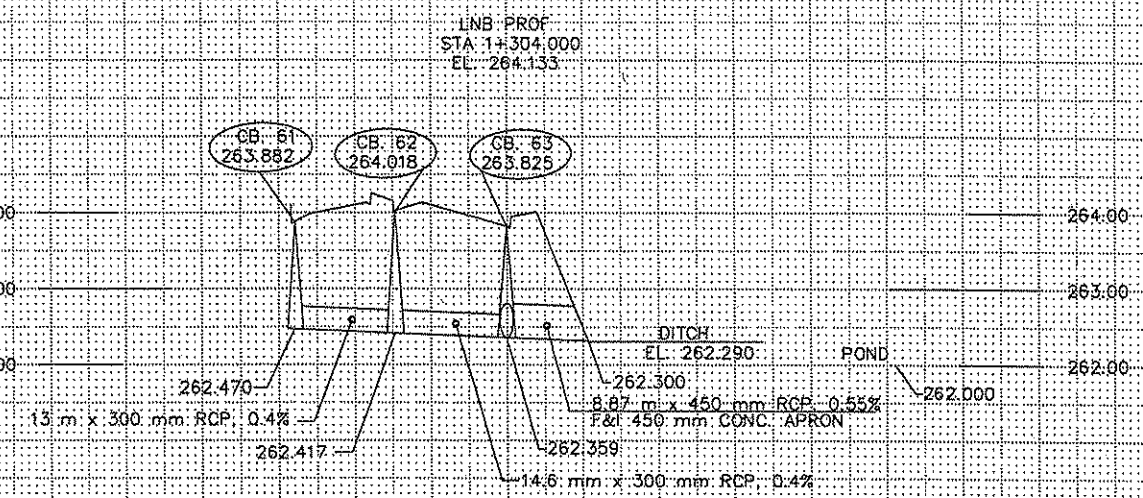
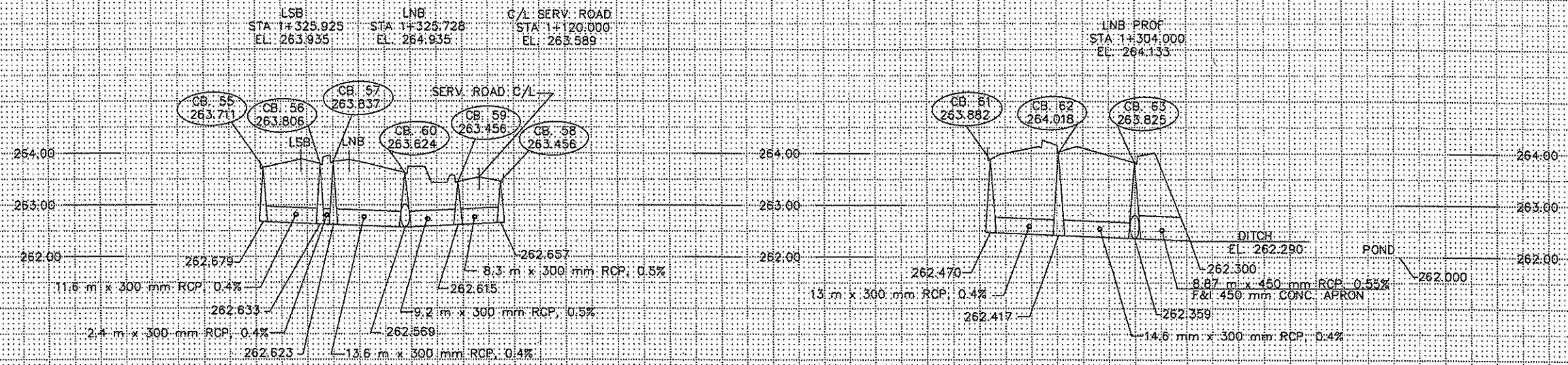

NO	DATE	BY	CKD	APPR	REVISION
12-Lateral.dwg	7-9-99				1:40:51 pm EST



I HEREBY CERTIFY THAT THIS PLAN WAS PREPARED BY ME OR UNDER MY DIRECT SUPERVISION AND THAT I AM A DULY REGISTERED PROFESSIONAL ENGINEER UNDER THE LAWS OF THE STATE OF MINNESOTA.

*Albert*

DATE 07-09-99 REG. NO. 25066

DRAWN BY: MN DATE 07-21-99  
 DESIGN BY: MN DATE 07-21-99  
 CHECKED BY: LR DATE \_\_\_\_\_

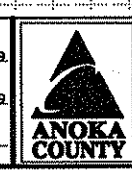

ANOKA COUNTY  
 HIGHWAY DEPT.

STATE PROJECT NO. 02-601-39  
 STATE PROJECT NO. 02-678-14  
 STATE PROJECT NO. 114-106-03  
 STATE PROJECT NO. 114-020-21

STORM SEWER  
 LATERALS

Sheet 18 of 40 Sheets

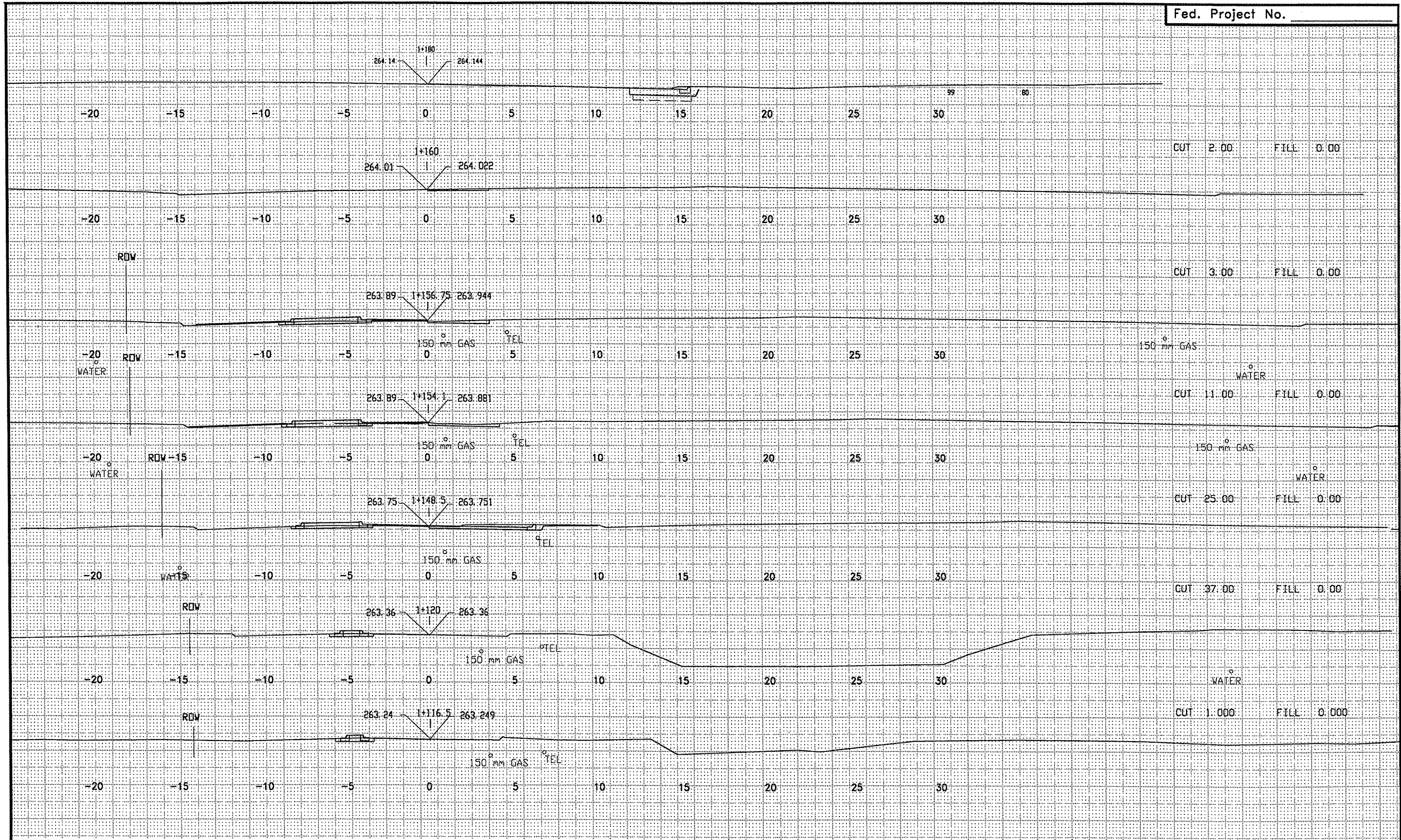

NO	DATE	BY	CHKD	APPR	REVISION
1	7-20-99	9:31:09 am EST			



I HEREBY CERTIFY THAT THIS PLAN WAS PREPARED BY ME OR UNDER MY DIRECT SUPERVISION AND THAT I AM A DULY REGISTERED PROFESSIONAL ENGINEER UNDER THE LAWS OF THE STATE OF MINNESOTA.

*Albert B.*  
DATE 07/09/99 REG. NO. 25066

DRAWN BY: MN DATE 07-19-99  
 DESIGN BY: MN DATE 07-19-99  
 CHECKED BY: LR DATE



ANOKA COUNTY  
HIGHWAY DEPT.

STATE PROJECT NO. 02-601-39  
 STATE PROJECT NO. 02-678-14  
 STATE PROJECT NO. 114-106-03  
 STATE PROJECT NO. 114-020-21

CROSS-SECTION  
 STA 1+100.00 TO 1+156.75  
 Sheet 19 of 40 Sheets

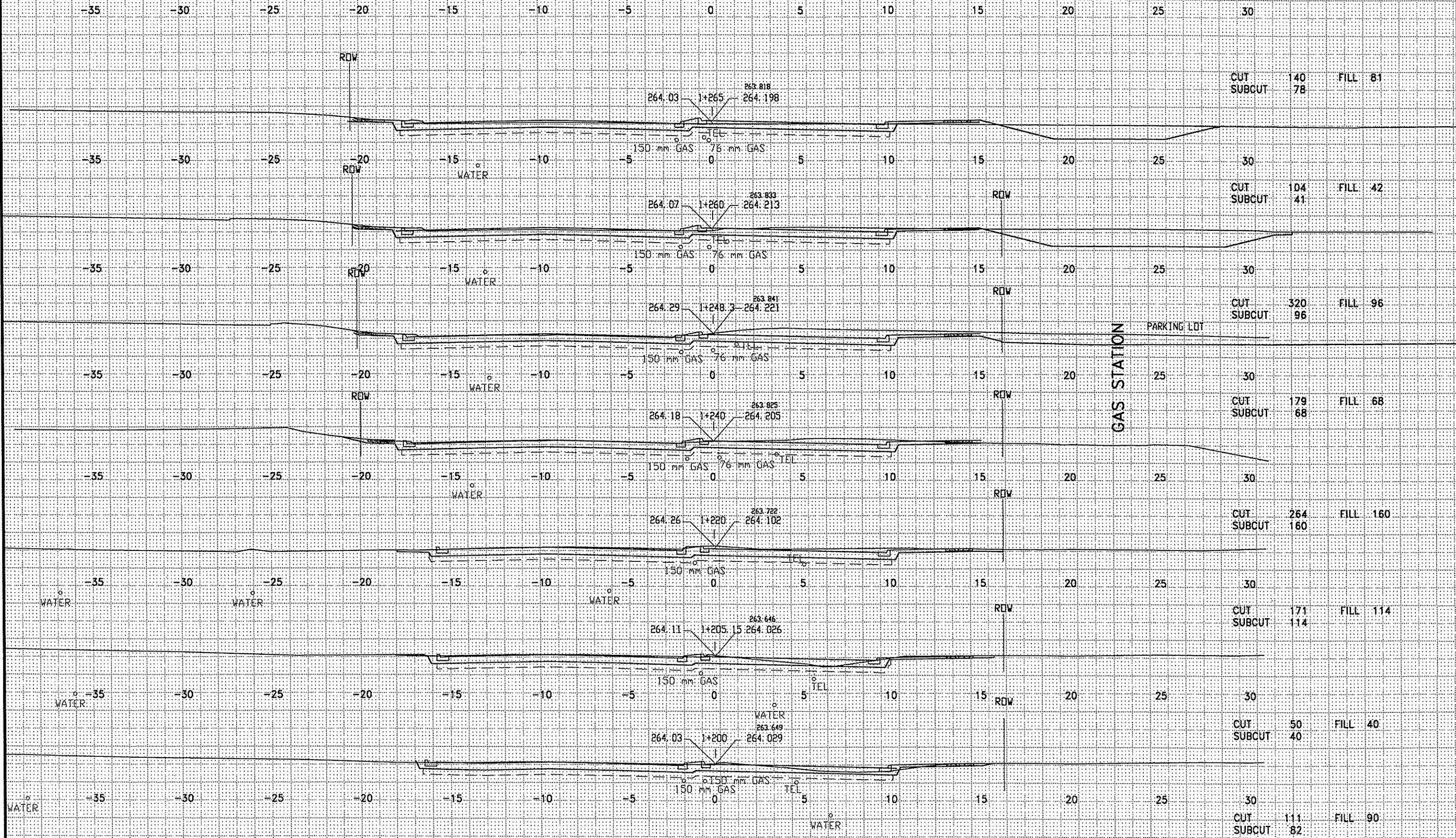

NO	DATE	BY	CHKD	APPR	REVISION
1	20-X-Sec.dwg	9-21-99	11:21:29 am	EST	



I HEREBY CERTIFY THAT THIS PLAN WAS PREPARED BY ME OR UNDER MY DIRECT SUPERVISION AND THAT I AM A DULY REGISTERED PROFESSIONAL ENGINEER UNDER THE LAWS OF THE STATE OF MINNESOTA.

*Allyson*

DATE 07/09/99 REG. NO. 25066

DRAWN BY: MN DATE 02-19-99  
 DESIGN BY: MN DATE 02-19-99  
 CHECKED BY: LR DATE



**ANOKA COUNTY**  
**HIGHWAY DEPT.**

STATE PROJECT NO. 02-601-39  
 STATE PROJECT NO. 02-678-14  
 STATE PROJECT NO. 114-106-03  
 STATE PROJECT NO. 114-020-21

**CROSS- SECTION**  
 STA 1+200.00 TO 1+265.00  
 Sheet 20 of 40 Sheets

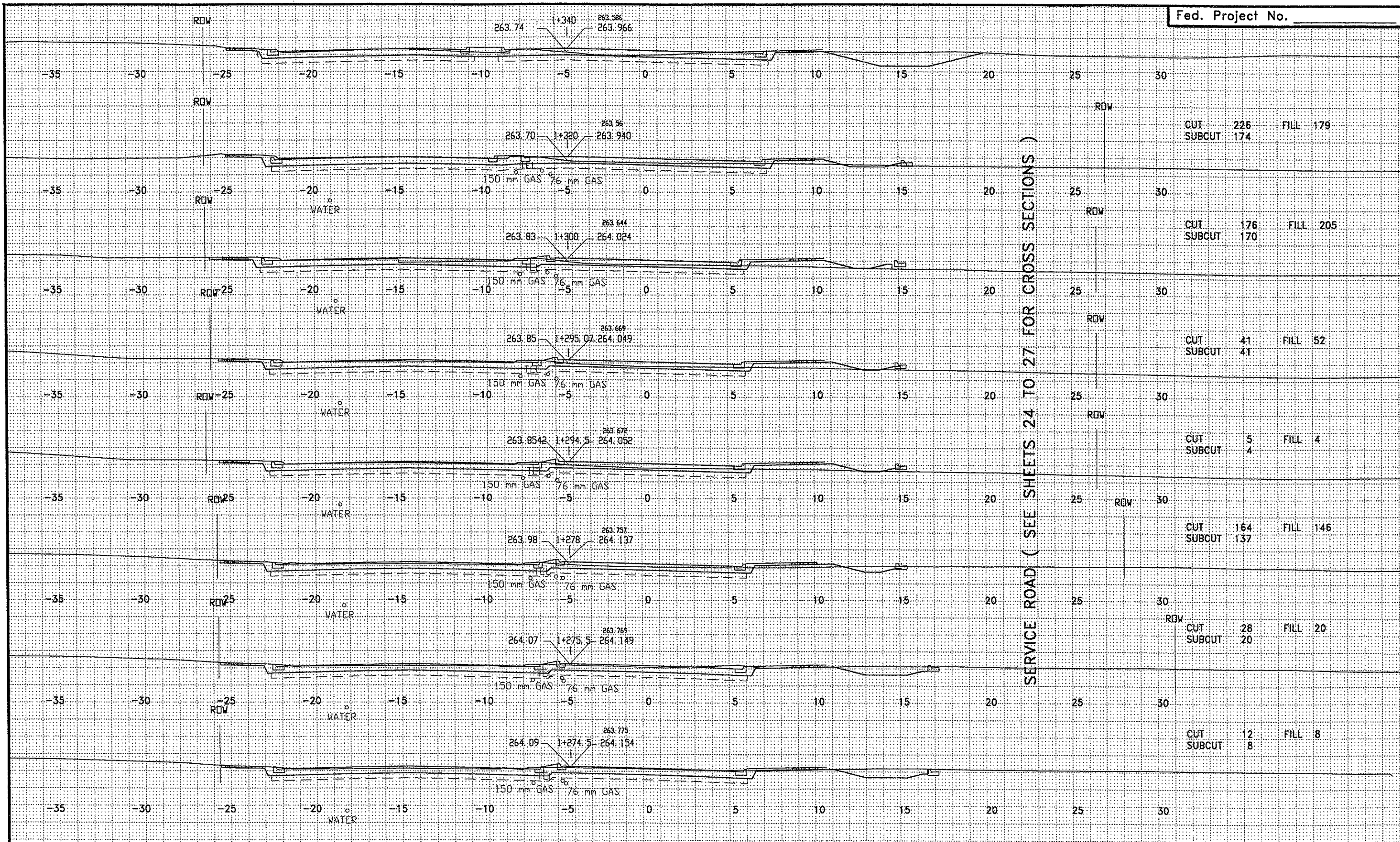

Section	CUT	SUBCUT	FILL
226	174		179
176	170		205
41	41		52
5	4		4
164	137		146
28	20		20
12	8		8

NO	DATE	BY	CKD	APPR	REVISION
NAME:	20-X-Sec.dwg	9-21-99	11:21:29 am EST		



I HEREBY CERTIFY THAT THIS PLAN WAS PREPARED BY ME OR UNDER MY DIRECT SUPERVISION AND THAT I AM A DULY REGISTERED PROFESSIONAL ENGINEER UNDER THE LAWS OF THE STATE OF MINNESOTA.

*Albert*

DATE 07/09/99 REG. NO. 25066

DRAWN BY MN DATE 07-19-99  
 DESIGN BY MN DATE 07-19-99  
 CHECKED BY LR DATE



ANOKA COUNTY  
 HIGHWAY DEPT.

STATE PROJECT NO. 02-601-39  
 STATE PROJECT NO. 02-678-14  
 STATE PROJECT NO. 114-106-03  
 STATE PROJECT NO. 114-020-21

CROSS- SECTION  
 STA 1+274.50 TO 1+320.00  
 Sheet 21 of 40 Sheets

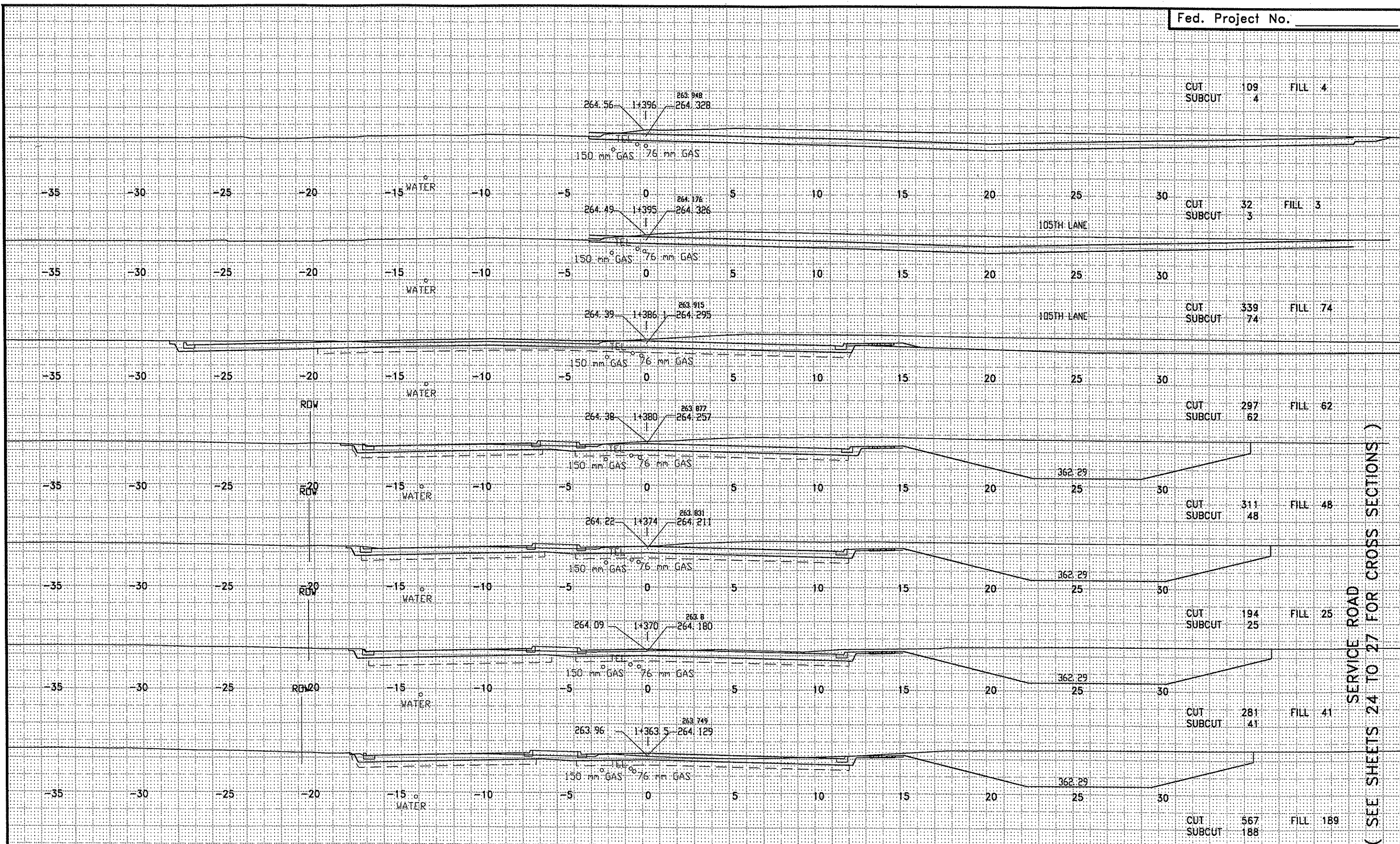

SERVICE ROAD (SEE SHEETS 24 TO 27 FOR CROSS SECTIONS)

NO	DATE	BY	CKD	APPR	REVISION
1	20-X-Sec.dwg	9-21-99			11:18:42 am EST



I HEREBY CERTIFY THAT THIS PLAN WAS PREPARED BY ME OR UNDER MY DIRECT SUPERVISION AND THAT I AM A DULY REGISTERED PROFESSIONAL ENGINEER UNDER THE LAWS OF THE STATE OF MINNESOTA.

*Allyson*

DATE 07/09/99 REG. NO. 25066

DRAWN BY \_\_\_\_\_ MN DATE 07-19-99  
 DESIGN BY \_\_\_\_\_ MN DATE 07-19-99  
 CHECKED BY \_\_\_\_\_ J.R. DATE \_\_\_\_\_



**ANOKA COUNTY**  
**HIGHWAY DEPT.**

STATE PROJECT NO. 02-601-39  
 STATE PROJECT NO. 02-678-14  
 STATE PROJECT NO. 114-106-03  
 STATE PROJECT NO. 114-020-21

**CROSS-SECTION**  
 STA 1+363.50 TO 1+396.00  
 Sheet 22 of 40 Sheets

from sta

1+396.54 To 1+480.90

metric

wearing course	50mm	53.656	Ton
Binder	undercarb 50mm	60.095	Ton
Bit curb		134.00	m
Tack coat		105.029	L
Aggregate		114.449	m <sup>3</sup>
concrete	775 (EV) - 21 <sup>3</sup>	=	753.78 m <sup>3</sup>

curb & bit Rem

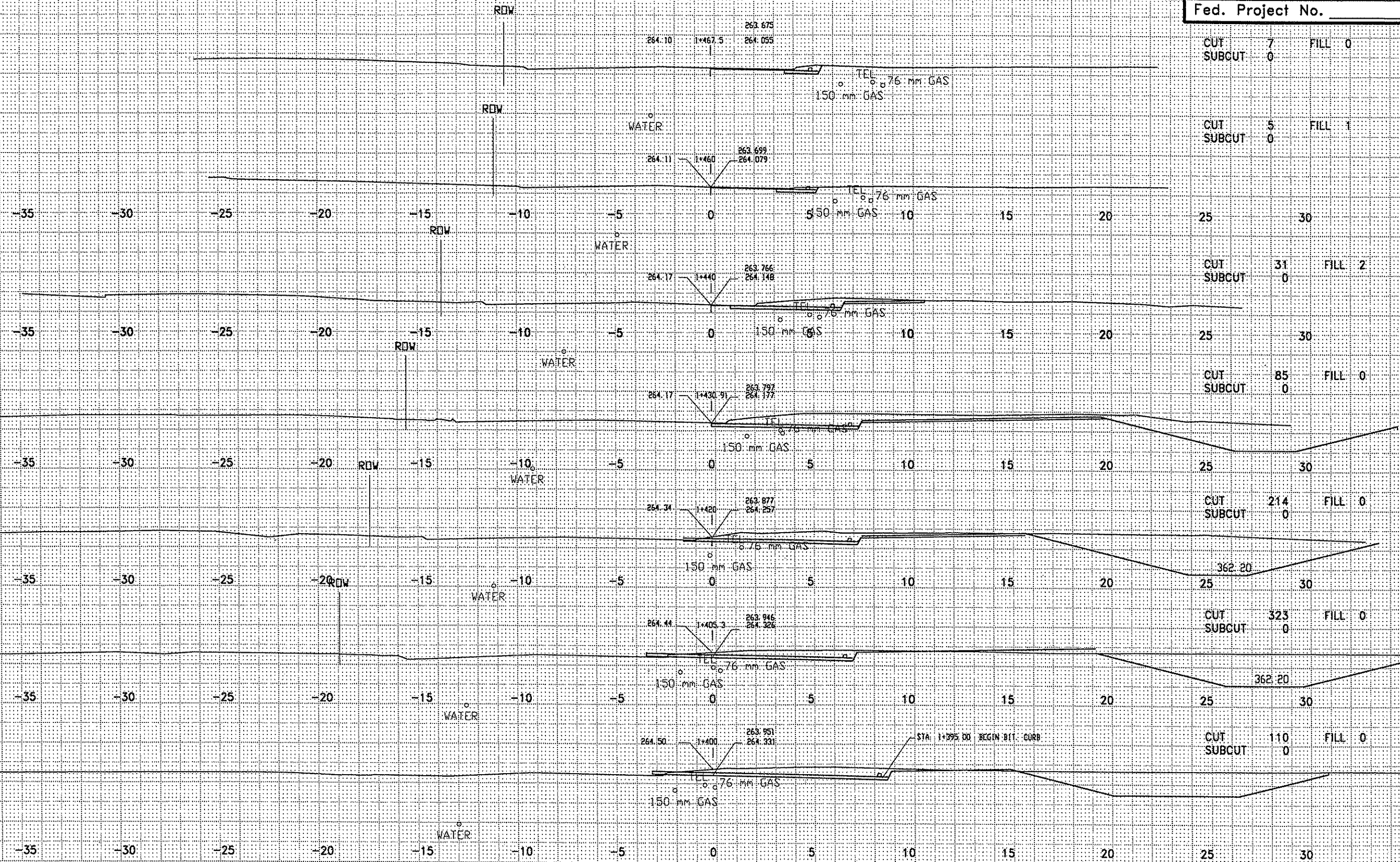

NO	DATE	BY	CKD	APPR	REVISION
1	20-X-Sec.dwg	9-21-99			11:18:42 am EST



I HEREBY CERTIFY THAT THIS PLAN WAS PREPARED BY ME OR UNDER MY DIRECT SUPERVISION AND THAT I AM A DULY REGISTERED PROFESSIONAL ENGINEER UNDER THE LAWS OF THE STATE OF MINNESOTA.

*Albert S.*  
DATE 07/09/99 REG. NO. 25066

DRAWN BY \_\_\_\_\_ MN DATE 07-19-99  
 DESIGN BY \_\_\_\_\_ MN DATE 07-19-99  
 CHECKED BY \_\_\_\_\_ LAR DATE 07-19-99

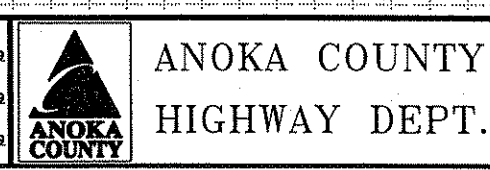

STATE PROJECT NO. 02-601-39  
 STATE PROJECT NO. 02-678-14  
 STATE PROJECT NO. 114-106-03  
 STATE PROJECT NO. 114-020-21

CROSS- SECTION  
 STA 1+400+00 TO 1+467.50  
 Sheet 23 of 40 Sheets



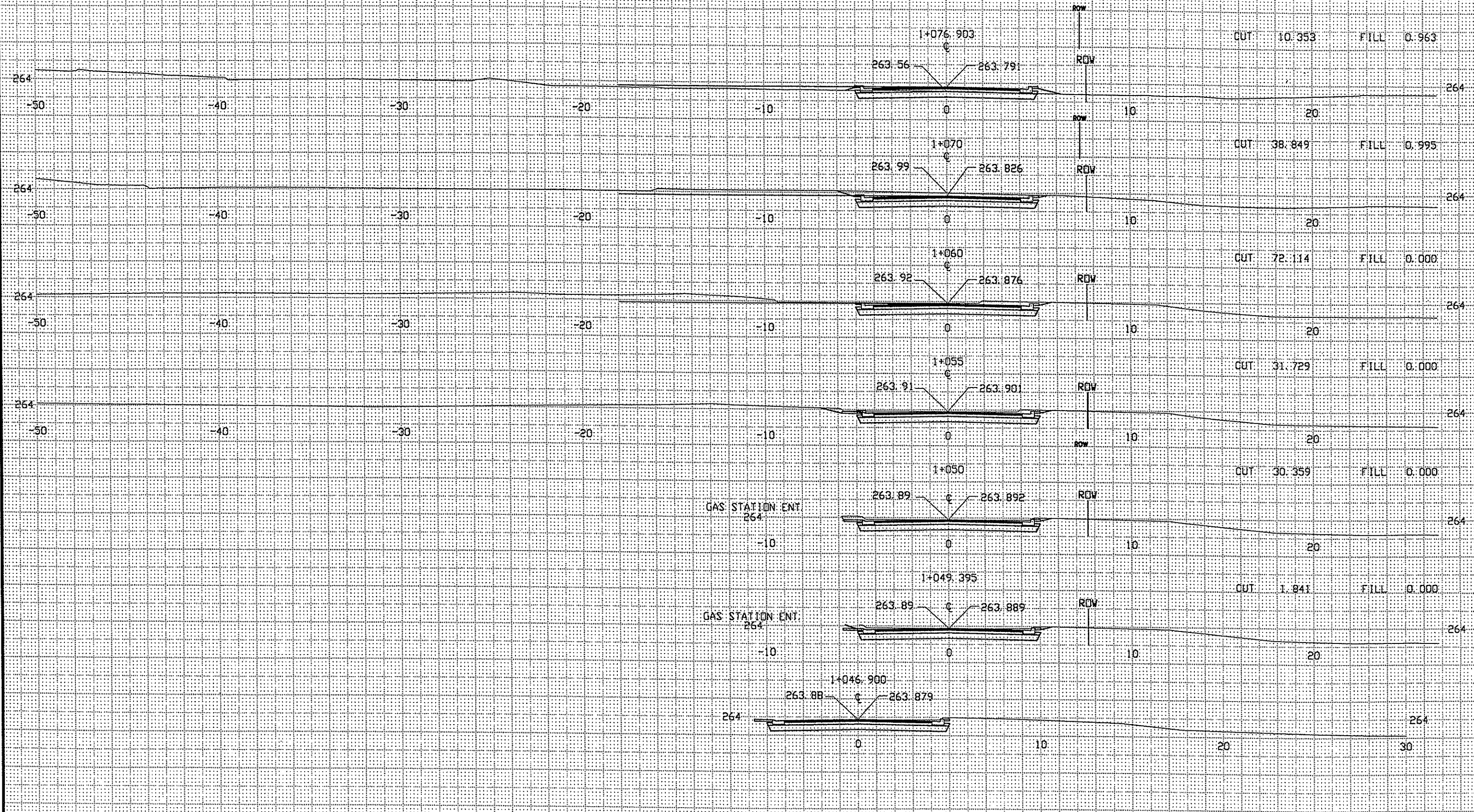

NO	DATE	BY	CKD	APPR	REVISION
1	10-27-99	CKD			4:23:22 pm EST

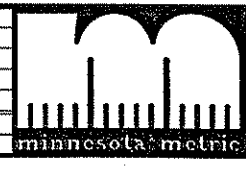

I HEREBY CERTIFY THAT THIS PLAN WAS PREPARED BY ME OR UNDER MY DIRECT SUPERVISION AND THAT I AM A DULY REGISTERED PROFESSIONAL ENGINEER UNDER THE LAWS OF THE STATE OF MINNESOTA.

*Albert*

DATE 07/09/99 REG. NO. 25066

DRAWN BY      MN DATE 07-19-99  
 DESIGN BY      MN DATE 07-19-99  
 CHECKED BY      LR DATE     



ANOKA COUNTY  
 HIGHWAY DEPT.

STATE PROJECT NO. 02-601-39  
 STATE PROJECT NO. 02-678-14  
 STATE PROJECT NO. 114-106-03  
 STATE PROJECT NO. 114-020-21

SERVICE ROAD  
 CROSS-SECTION  
 STA 1+046.90 TO 1+080.00  
 Sheet 24 of 40 Sheets

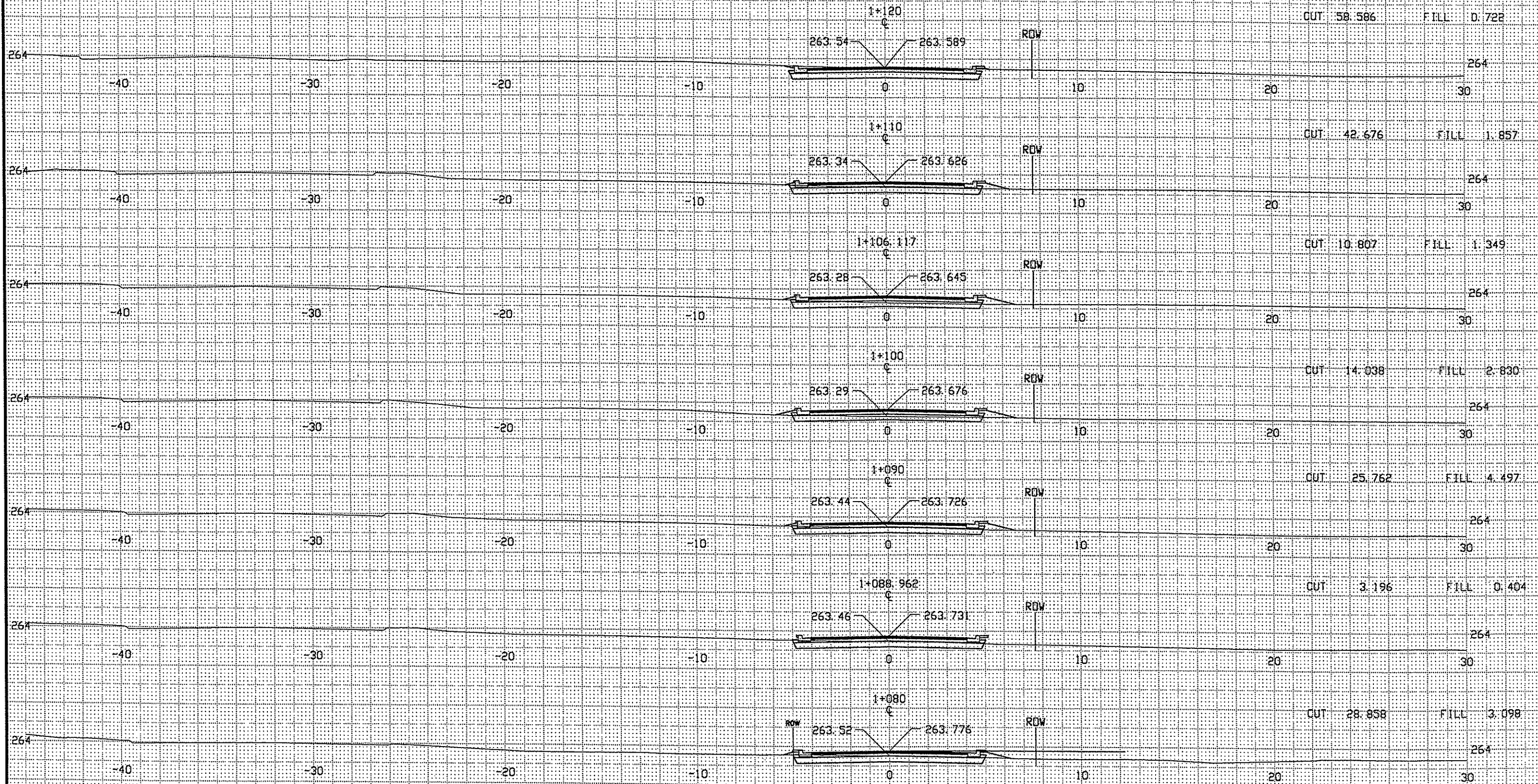

NO	DATE	BY	CKD	APPR	REVISION
NAME: 20-X-Sec.dwg	10-27-99	4:23:22 pm EST			



I HEREBY CERTIFY THAT THIS PLAN WAS PREPARED BY ME OR UNDER MY DIRECT SUPERVISION AND THAT I AM A DULY REGISTERED PROFESSIONAL ENGINEER UNDER THE LAWS OF THE STATE OF MINNESOTA.

*Allyson*

DATE 07/09/99 REG. NO. 25066

DRAWN BY \_\_\_\_\_ MN DATE 02-19-99  
 DESIGN BY \_\_\_\_\_ MN DATE 02-19-99  
 CHECKED BY \_\_\_\_\_ LR DATE \_\_\_\_\_

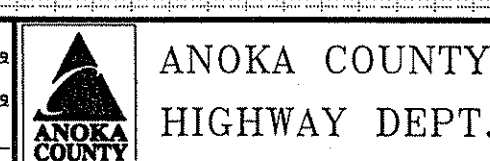

ANOKA COUNTY HIGHWAY DEPT.

STATE PROJECT NO. 02-601-39  
 STATE PROJECT NO. 02-678-14  
 STATE PROJECT NO. 114-106-03  
 STATE PROJECT NO. 114-020-21

SERVICE ROAD CROSS-SECTION  
 STA 1+088.96 TO 1+130.00  
 Sheet 25 of 40 Sheets

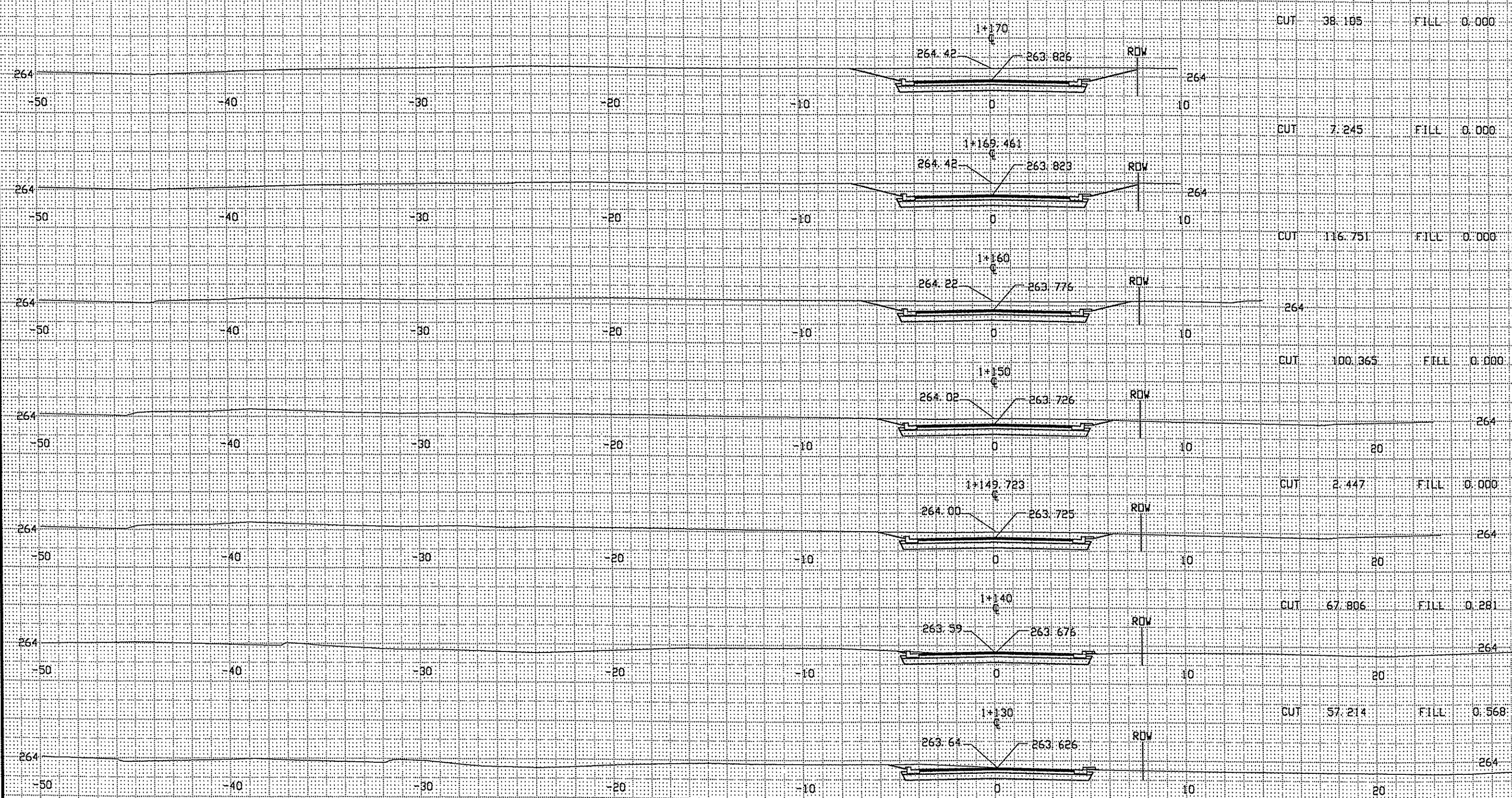

NO	DATE	BY	CKD	APPR	REVISION
NAME: 20-X-Sec.dwg	10-27-99	4:23:22 pm	EST		



I HEREBY CERTIFY THAT THIS PLAN WAS PREPARED BY ME OR UNDER MY DIRECT SUPERVISION AND THAT I AM A DULY REGISTERED PROFESSIONAL ENGINEER UNDER THE LAWS OF THE STATE OF MINNESOTA.

*Allyson*

DATE 07/09/99 REG. NO. 25066

DRAWN BY \_\_\_\_\_ MN DATE 07-19-99  
 DESIGN BY \_\_\_\_\_ MN DATE 07-19-99  
 CHECKED BY \_\_\_\_\_ LR DATE \_\_\_\_\_



ANOKA COUNTY  
 HIGHWAY DEPT.

STATE PROJECT NO. 02-601-39  
 STATE PROJECT NO. 02-678-14  
 STATE PROJECT NO. 114-106-03  
 STATE PROJECT NO. 114-020-21

SERVICE ROAD  
 CROSS-SECTION  
 STA 1+140.00 TO 1+172.80  
 Sheet 26 of 40 Sheets

MATCH TO LNB STA 1+392.20, ELEV 264.25

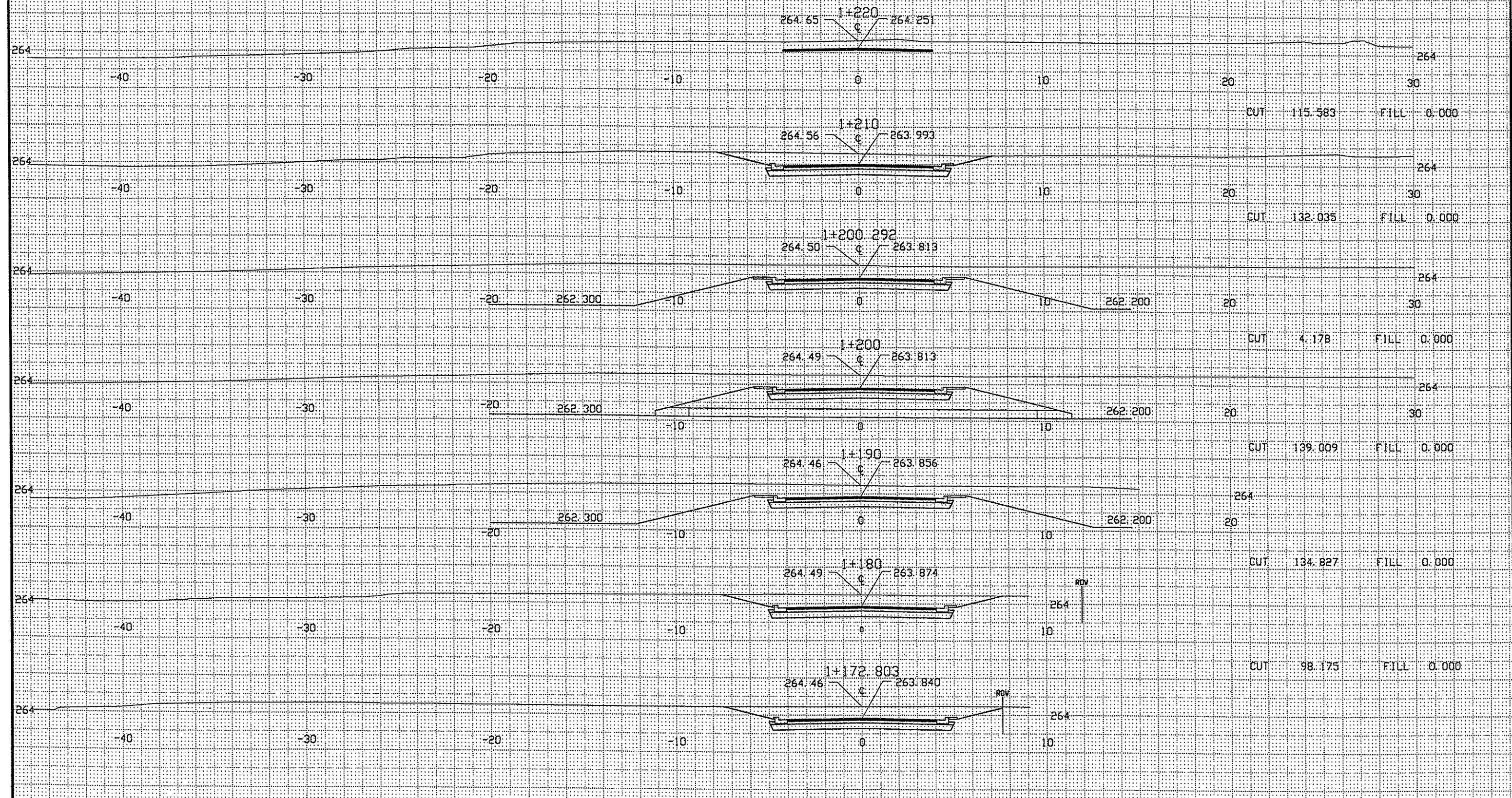

NO	DATE	BY	CKD	APPR	REVISION
NAME: 20-X-Sec.dwg	10-27-99	4:23:22 pm EST			



I HEREBY CERTIFY THAT THIS PLAN WAS PREPARED BY ME OR UNDER MY DIRECT SUPERVISION AND THAT I AM A DULY REGISTERED PROFESSIONAL ENGINEER UNDER THE LAWS OF THE STATE OF MINNESOTA.

*Allyson*

DATE 07/09/99 REG. NO. 25066

DRAWN BY \_\_\_\_\_ MN DATE 02-19-99  
 DESIGN BY \_\_\_\_\_ MN DATE 07-19-99  
 CHECKED BY \_\_\_\_\_ LR DATE \_\_\_\_\_

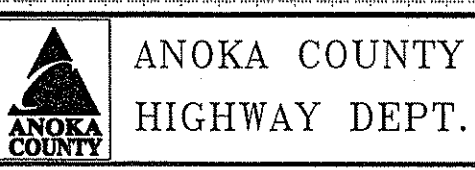

STATE PROJECT NO. 02-601-39  
 STATE PROJECT NO. 02-678-14  
 STATE PROJECT NO. 114-106-03  
 STATE PROJECT NO. 114-020-21

SERVICE ROAD  
 CROSS-SECTION  
 STA 1+180.00 TO 1+220.00  
 Sheet 27 of 40 Sheets

LOOP DETECTORS			
NUMBER	SIZE	LOCATION	FUNCTION
D1-1	2-1.7x1.7	6m & 15m	1
D1-2	2-1.7x1.7	1.5m & 11m	1
D2-1	1.7x1.7	92 m	1
D2-2	1.7x1.7	92 m	1
D3-1	1.7x1.7	76 m	3.8
D3-2	2-1.7x1.7	1.5m & 4.5m	1
D3-3	2-1.7x1.7	6m & 15m	1
D3-4	2-1.7x1.7	1.5m & 11m	1
D3-5	2-1.7x1.7	6m & 15m	1
D3-6	2-1.7x1.7	1.5m & 11m	1
D4-1	1.7x1.7	37 m	3.8
D4-2	2-1.7x1.7	1.5m & 4.5m	1
D4-3	2-1.7x1.7	1.5m & 4.5m	1
D4-4	2-1.7x1.7	6m & 15m	1
D4-5	2-1.7x1.7	1.5m & 11m	1
D5-1	2-1.7x1.7	6m & 15m	1
D5-2	2-1.7x1.7	1.5m & 11m	1
D6-1	1.7x1.7	92 m	1
D6-2	1.7x1.7	92 m	1

LOCATION = DISTANCE IN METERS FROM THE STOP BAR TO FRONT OF DETECTOR

- 1) CALL & EXTEND
- 2) CALL ONLY
- 3) EXTEND ONLY
- 4) CALL ONLY DENSITY
- 5) DELAY CALL ONLY
- 6) DELAY CALL ONLY DENSITY
- 7) DELAY CALL IMMEDIATE EXTEND
- 8) CARRY OVER
- 9) ADVISORY

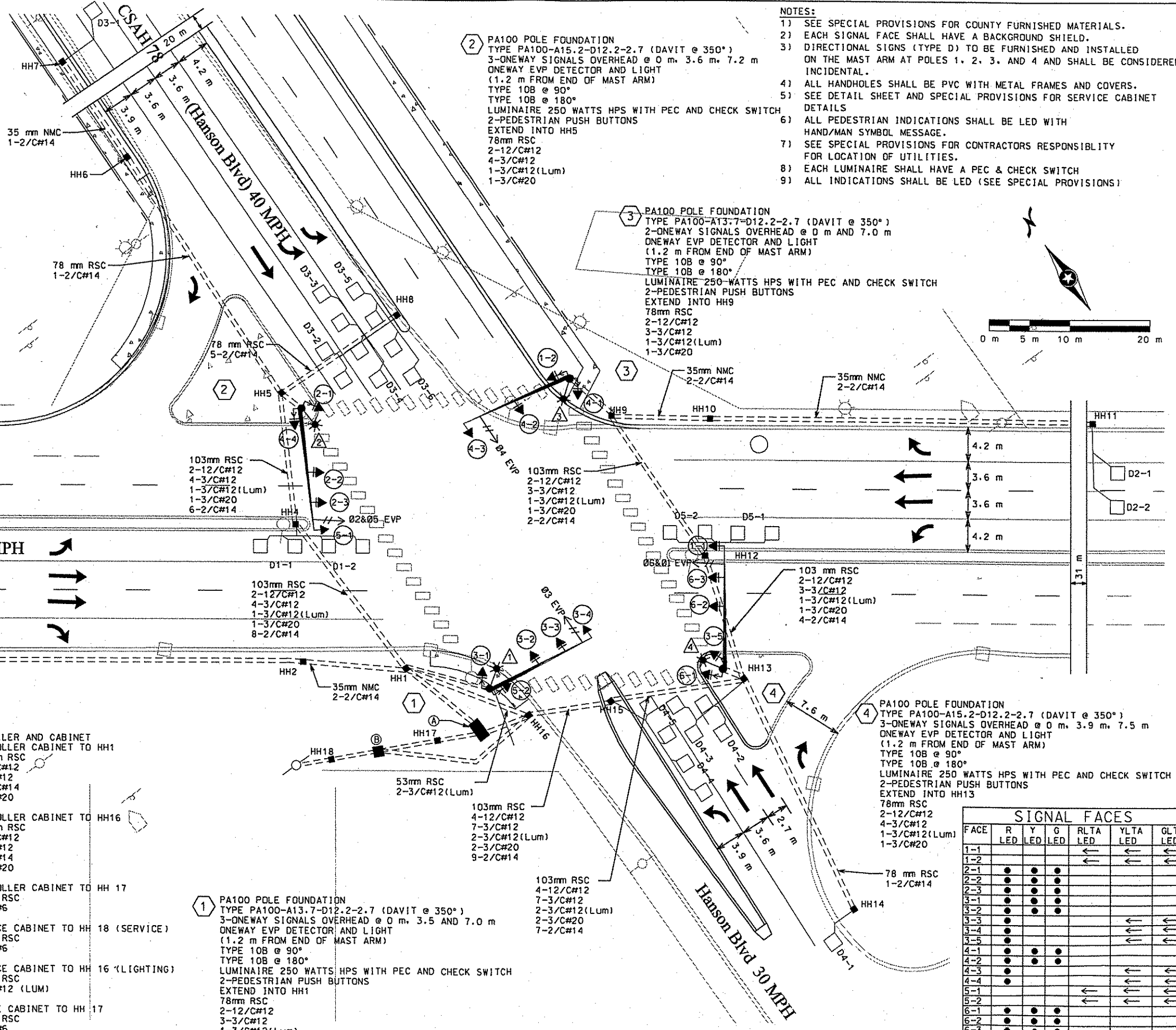

- NOTES:
- 1) SEE SPECIAL PROVISIONS FOR COUNTY FURNISHED MATERIALS.
  - 2) EACH SIGNAL FACE SHALL HAVE A BACKGROUND SHIELD.
  - 3) DIRECTIONAL SIGNS (TYPE D) TO BE FURNISHED AND INSTALLED ON THE MAST ARM AT POLES 1, 2, 3, AND 4 AND SHALL BE CONSIDERED INCIDENTAL.
  - 4) ALL HANDHOLES SHALL BE PVC WITH METAL FRAMES AND COVERS.
  - 5) SEE DETAIL SHEET AND SPECIAL PROVISIONS FOR SERVICE CABINET DETAILS
  - 6) ALL PEDESTRIAN INDICATIONS SHALL BE LED WITH HAND/MAN SYMBOL MESSAGE.
  - 7) SEE SPECIAL PROVISIONS FOR CONTRACTORS RESPONSIBILITY FOR LOCATION OF UTILITIES.
  - 8) EACH LUMINAIRE SHALL HAVE A PEC & CHECK SWITCH
  - 9) ALL INDICATIONS SHALL BE LED (SEE SPECIAL PROVISIONS)

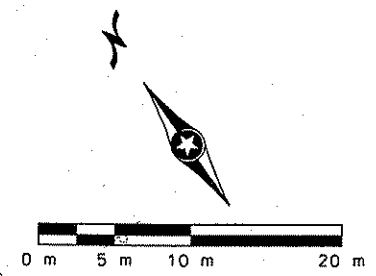

REVISION NO.	DATE	BY	CHK	APP	DATE

AS NOTED

SCALE: 1" = 10'

DATE: 5/28/99

REG. NO. 26082

CSAH 1 (Coon Rapids Blvd)  
at CSAH 78 (Hanson Blvd)  
Anoka County, Minnesota



350 Westwood Lake Office  
6441 Weyzata Boulevard  
Minneapolis, MN 55426  
612-641-4800  
FAX 612-641-1700



INFRASTRUCTURE - ENGINEERS - PLANNERS

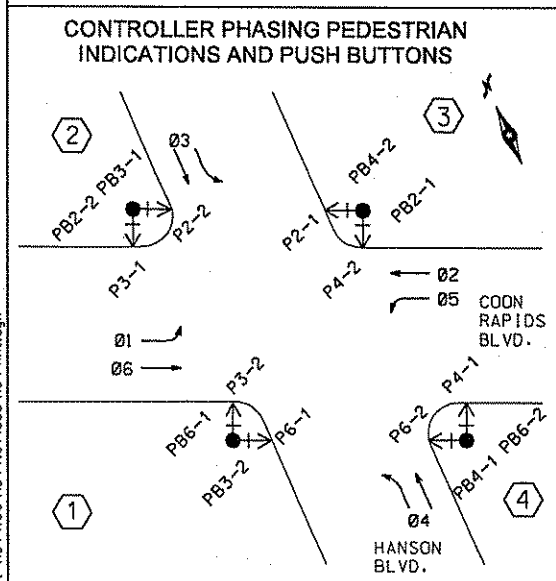

- (A) CONTROLLER AND CABINET  
CONTROLLER CABINET TO HH1  
103 mm RSC  
4-12/C#12  
7-3/C#12  
10-2/C#14  
2-3/C#20
- CONTROLLER CABINET TO HH16  
103 mm RSC  
4-12/C#12  
7-3/C#12  
9-2/C#14  
2-3/C#20
- CONTROLLER CABINET TO HH 17  
35 mm RSC  
3-1/C#6
- (B) SERVICE CABINET TO HH 18 (SERVICE)  
53 mm RSC  
3-1/C#6
- SERVICE CABINET TO HH 16 (LIGHTING)  
35 mm RSC  
4-3/C#12 (LUM)
- SERVICE CABINET TO HH 17  
35 mm RSC  
3-1/C#6
- S.O.P. IN PLACE WOOD POLE  
53 mm RSC

- (1) PA100 POLE FOUNDATION  
TYPE PA100-A13.7-D12.2-2.7 (DAVIT @ 350°)  
3-ONEWAY SIGNALS OVERHEAD @ 0 m, 3.5 AND 7.0 m  
ONEWAY EVP DETECTOR AND LIGHT  
(1.2 m FROM END OF MAST ARM)  
TYPE 10B @ 90°  
TYPE 10B @ 180°  
LUMINAIRE 250 WATTS HPS WITH PEC AND CHECK SWITCH  
2-PEDESTRIAN PUSH BUTTONS  
EXTEND INTO HH1  
78mm RSC  
2-12/C#12  
3-3/C#12  
1-3/C#12(Lum)  
1-3/C#20

S.P. 02-601-39, S.P. 114-106-03  
S.P. 02-678-14

INTERSECTION LAYOUT

SHEET 28 OF 40 SHEETS

FACE	SIGNAL FACES					
	R LED	Y LED	G LED	RLTA LED	YLTA LED	GLTA LED
1-1						
1-2						
2-1	●	●	●			
2-2	●	●	●			
2-3	●	●	●			
3-1	●	●	●			
3-2	●	●	●			
3-3	●	●	●			
4-1	●	●	●			
4-2	●	●	●			
4-3	●	●	●			
4-4	●	●	●			
5-1				←	←	←
5-2				←	←	←
6-1	●	●	●			
6-2	●	●	●			
6-3	●	●	●			

**CONTROLLER CABINET**

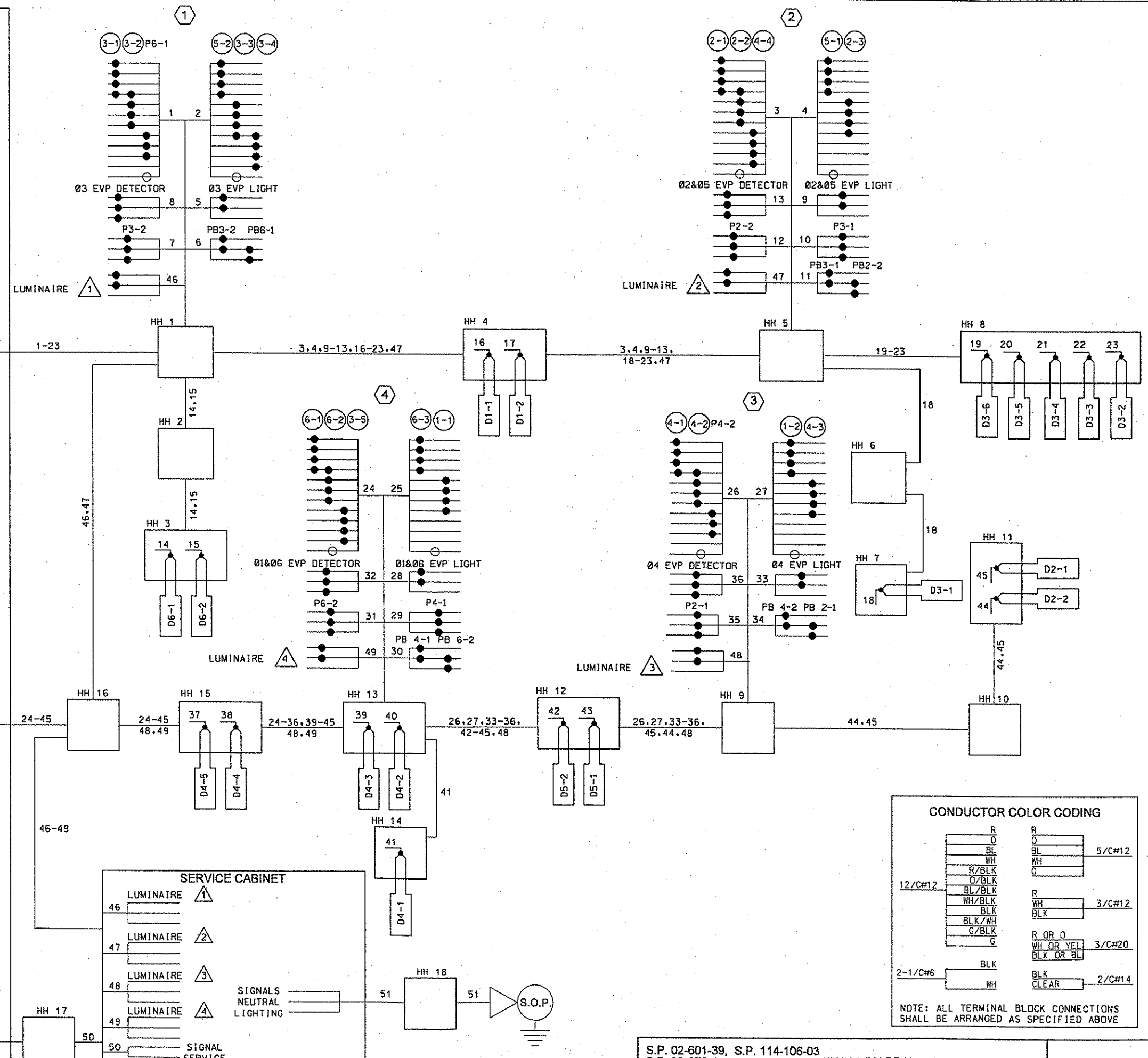
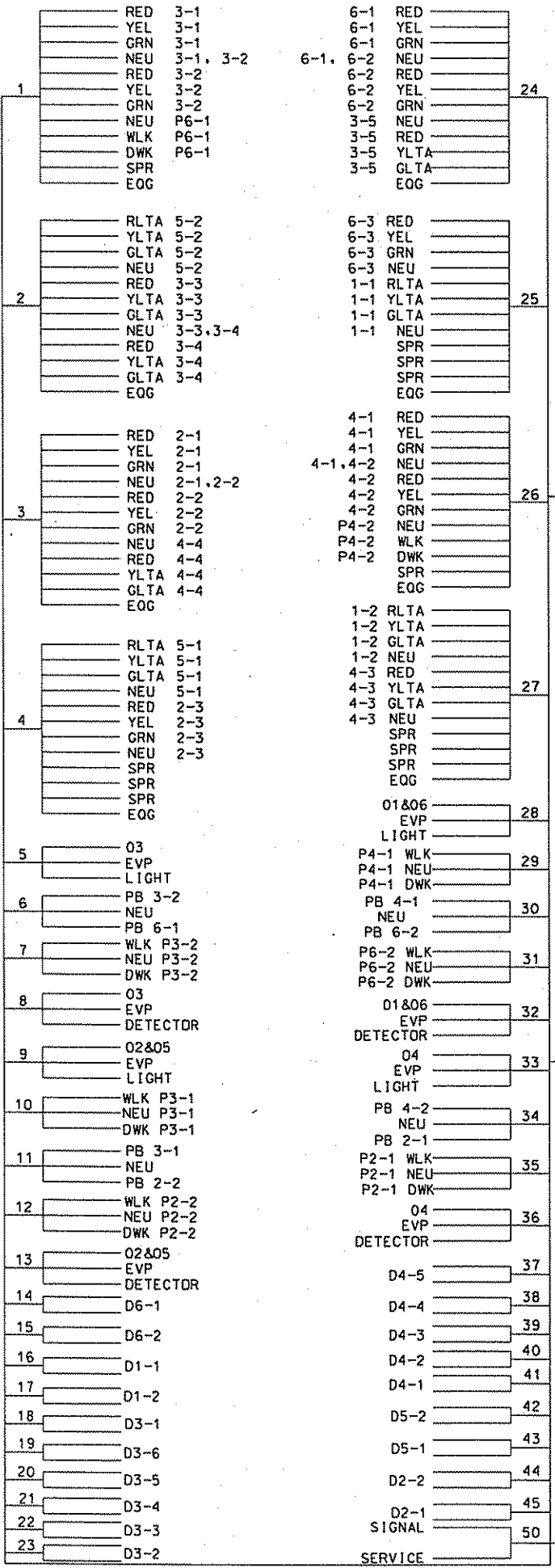

**CONDUCTOR COLOR CODING**

12/C#12	R	R
	BL	BL
	WH	WH
	R/BLK	5/C#12
	G/BLK	
	BL/BLK	
	WH/BLK	3/C#12
	BLK	BLK
	BLK/WH	
	G/BLK	
	WH	
2-1/C#6	BLK	R OR O
	WH	WH OR YEL
		3/C#20
		BLK OR BL
		BLK CLEAR
		2/C#14

NOTE: ALL TERMINAL BLOCK CONNECTIONS SHALL BE ARRANGED AS SPECIFIED ABOVE

REVISION NO. DATE 10/20/99

AS NOTED

SCALE: 1" = 10'

DESIGN BY: CTR

CHECK BY: RB

PROJECT NO: 1044.01

RECORD COPY BY:

DATE: 5/28/99 REG. NO. 26082

CSAH 1 (Coon Rapids Blvd) at CSAH 78 (Hanson Blvd) Anoka County, Minnesota

350 Westwood Lake Office  
8441 Wayzata Boulevard  
Minneapolis, MN 55425  
612-541-4800  
FAX 641-1700

W.S.B. & Associates, Inc.  
INFRASTRUCTURE - ENGINEERS - PLANNERS

I:\1044.00\1044.01\cadd\1044.dwt

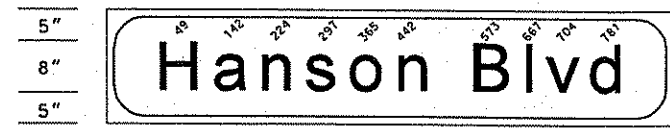

88" x 18", 3.0"R, 1.0"B, D-1  
LINE 1 : 78.28 : 8" - 6" E MOD



122" x 18", 3.0"R, 1.0"B, D-2  
LINE 1 : 110.75 : 8" - 6" E MOD

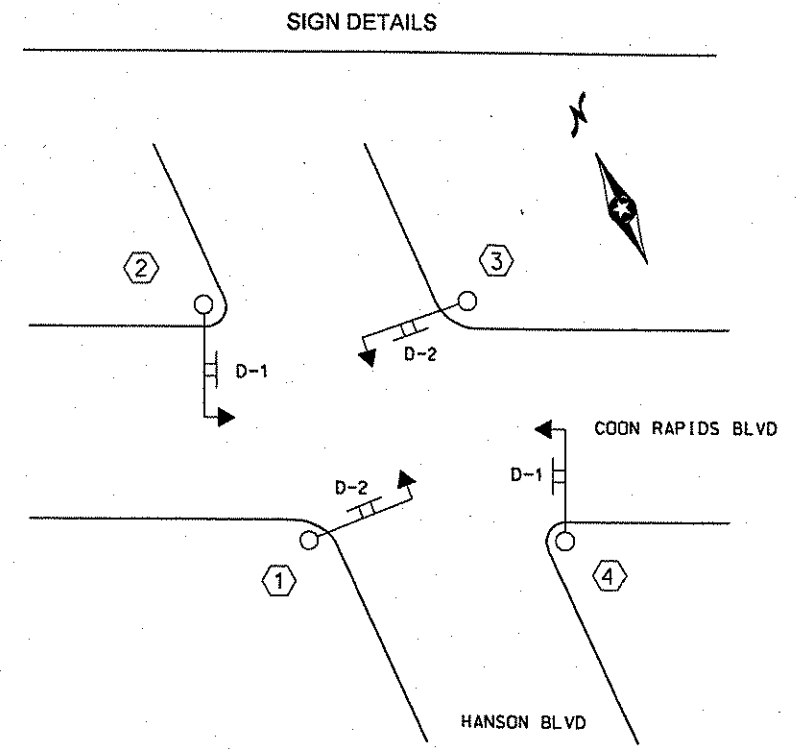

TYPE D SIGNS							
SIGN PANEL	SIZE (")	NO. REQUIRED	NO. POSTS PER SIGN	POST SPACING (")	SO FT PER SIGN	POLE NO.	LOCATION A ON MASTARM ①
D-1	88 x 18	2	2	24"	11.00	2	35.7'
						4	35.7'
D-2	122 x 18	2	3	45"	15.25	1	22.8'
						3	27.8'

① ALL DISTANCES MEASURED FROM THE END OF THE MASTARM.

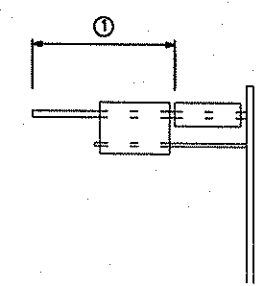

- NOTES:
- 1) FOR STRUCTURAL DETAILS, TYPE "D" SIGNS, SEE STANDARD SIGNS MANUAL, PAGES 105A AND 105B.
  - 2) FOR TYPE "D" STRINGER AND PANEL JOINT DETAIL, SEE STANDARD SIGNS MANUAL.
  - 3) SEE STANDARD SIGNS MANUAL FOR ARROW AND OVERLAY DETAILS.
  - 4) CORNERS EXTENDING BEYOND THE BORDER SHALL NOT BE TRIMMED.
  - 5) COLOR - WHITE LEGEND AND BORDER ON GREEN BACKGROUND, FULLY REFLECTORIZED.

HEREBY CERTIFY THAT THIS PLAN, SPECIFICATION OR REPORT WAS PREPARED BY ME OR UNDER MY DIRECT SUPERVISION AND THAT I AM A LICENSED PROFESSIONAL ENGINEER UNDER THE LAWS OF THE STATE OF MINNESOTA.

*Charles T. Rickman, P.E.*  
CHARLES T. RICKMAN, P.E.  
DATE: 5/28/95 REG. NO. 26082

CSAH 1 (Coon Rapids Blvd)  
at CSAH 78 (Hanson Blvd)  
Anoka County, Minnesota



350 Westwood Lake Office  
8441 Weyzata Boulevard  
Minneapolis, MN 55426  
612-541-6800  
FAX 641-1700



**CONSTRUCTION NOTES**

ENCLOSURE SHALL BE FABRICATED FROM #12 GA. ALL WELDED COLD ROLLED STEEL FOR OUTDOOR WEATHER PROOF SERVICE. DOORS TO BE GASKETED, ALL HINGES, PINS AND LOCKS TO BE OF NON CORRODING CONSTRUCTION. CABINET TO BE PRIMED INSIDE AND OUT WITH RUST INHIBITTING PRIMER. FINISH PER MN/DOT #3527. ENCLOSURE SHALL BE 'UL' APPROVED

N.S.P. METER SOCKET, 5-TERMINAL w/POSTIVE BY-PASS MECHANISM MILBANK CAT. No. U-2272-RL.

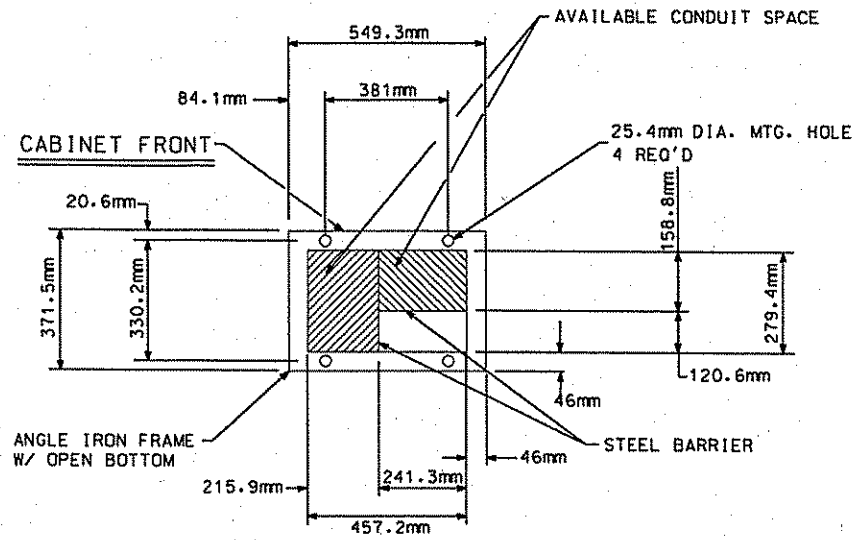
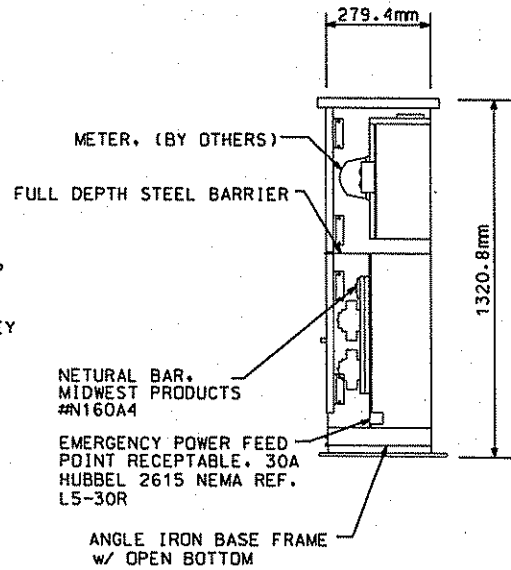
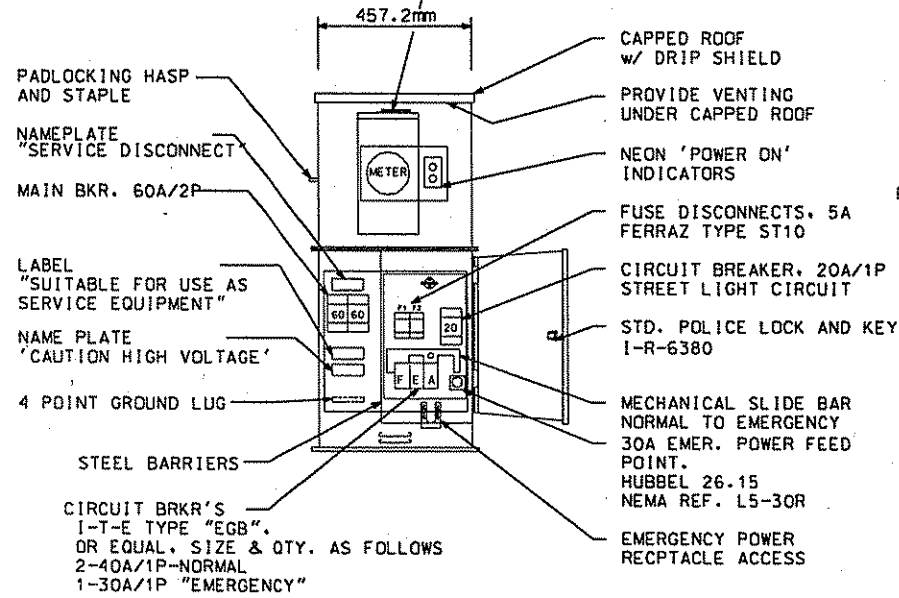

**SERVICE CABINET FOUNDATION**

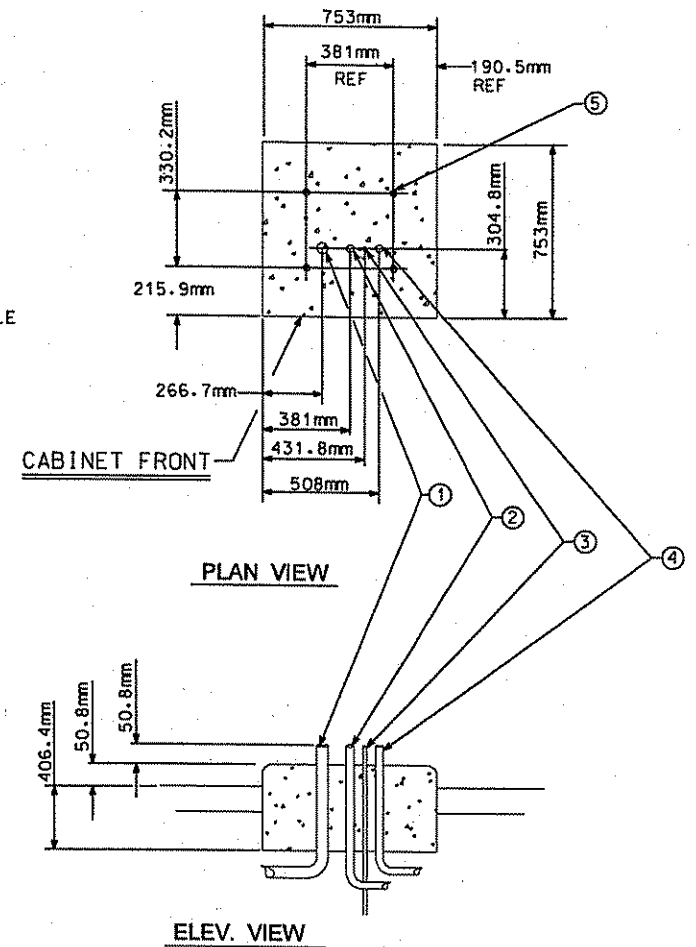

- ① 53mm RSC FROM SOURCE OF POWER (VIA HH18)
- ② 35mm RSC TO CONTROLLER CABINET (VIA HANDHOLE 17)
- ③ GROUNDING ROD
- ④ 35mm RSC TO HANDHOLE 16 ( STREET LIGHTING)
- ⑤ ANCHOR BOLT LOCATIONS (4 REQUIRED)

**SIGNAL SERVICE CABINET**

- A 78 mm R.S.C. FOR SERVICE CONNECTION TO HH 17
- B 103 mm R.S.C. TO HH 1
- C 103 mm R.S.C. TO HH 16
- D 16 mm DIA X 4.8 m GROUND ROD
- E (2) 78 mm RSC STUBOUTS, AT ROADS CAP BOTH ENDS.

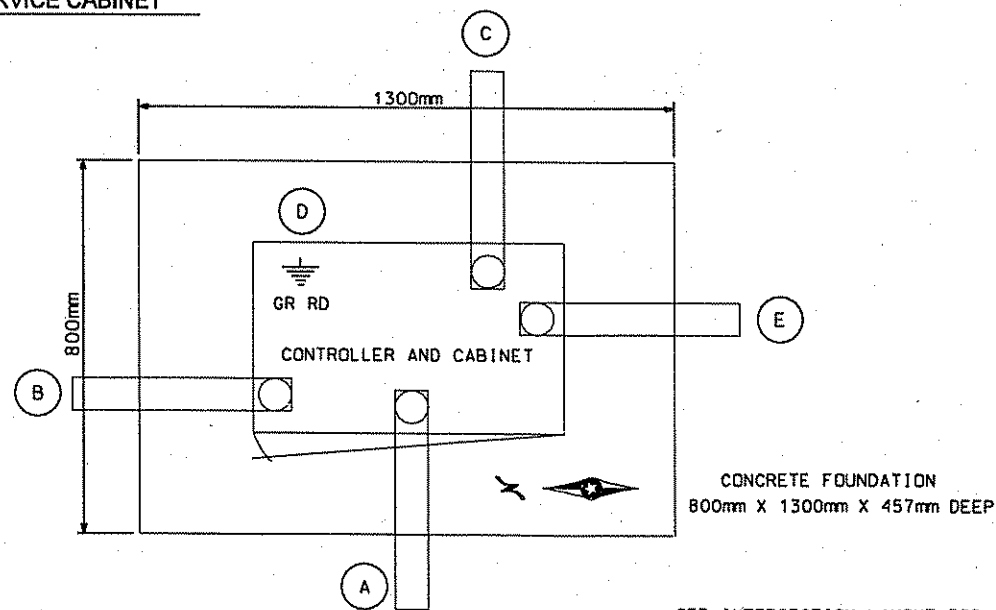

SEE INTERSECTION LAYOUT FOR CONDUIT & CABLE INFORMATION

**CONTROLLER CABINET PAD LAYOUT**

NO SCALE

REVISION NO.	DATE	EXPLANATION

CSAH 1 (Coon Rapids Blvd) at CSAH 78 (Hanson Blvd) Anoka County, Minnesota



350 Westwood Lake Office  
8441 Weyzata Boulevard  
Minneapolis, MN 55426  
612-541-8800  
FAX 612-541-7700

**WSB**  
& Associates, Inc.  
INFRASTRUCTURE ENGINEERS - PLANNERS



**ABBREVIATIONS**

3-1(EG) SIGNAL HEAD PHASE "3" - NO. "1"	P1-(EG) PEDESTRIAN INDICATION PHASE "2"-NO. "1"
BR. GR. BARE GROUND	PB PUSH BUTTON
CH. SW. CHECK SWITCH	PB-2(EG) PUSH BUTTON PHASE "2"-NO. "1"
CLR CLEAR	PEC PHOTOELECTRIC CELL
D2-1(EG) DETECTOR PHASE "2" - NO. "1"	PED PEDESTRIAN
DWK DON'T WALK	R RED
EOG EQUIPMENT GROUND	R&S REMOVE AND SALVAGE
EVP EMERGENCY VEHICLE PRE-EMPTION	RLTA RED LEFT TURN ARROW
F&I FURNISH AND INSTALL	RRTA RED RIGHT TURN ARROW
FL FLASH/FLASHING	RSC RIGID STEEL CONDUIT
G GREEN	SOP SOURCE OF POWER
GLTA GREEN LEFT TURN ARROW	SPR SPARE
GRN GREEN	ST. LHT. STREET LIGHT
GR. R. GROUND ROD	STA STATION
GRTA GREEN RIGHT TURN ARROW	SW SWITCH
GTHA GREEN THRU ARROW	SWD SWITCHED
HH HANDHOLE	TDW TELEPHONE DROP WIRE
HPS HIGH PRESSURE SODIUM	WLK WALK
JB JUNCTION BOX	YEL YELLOW
LUM LUMINAIRE	YLTA YELLOW LEFT TURN ARROW
NEU NEUTRAL	YRTA YELLOW RIGHT TURN ARROW
NMC NONMETALLIC CONDUIT	YTHA YELLOW THRU ARROW

**LEGEND OF SYMBOLS**

CONTROLLER AND SERVICE EQUIP. NO's	(A)
SIGNAL BASE NO.	(1)
SIGNAL FACE NO.	(2)
LUMINAIRE NO.	(3)
CONTROLLER AND CABINET	(4)
CONTROLLER AND CABINET - IN PLACE	(5)
HANDHOLE	(6)
HANDHOLE - IN PLACE	(7)
RIGID STEEL CONDUIT (RSC)	(8)
RIGID STEEL CONDUIT (RSC) - IN PLACE	(9)
SIGNAL FACE WITH BACKGROUND SHIELD	(10)
SIGNAL FACE W/O BACKGROUND SHIELD	(11)
SIGNAL FACE - IN PLACE	(12)
PEDESTRIAN INDICATORS	(13)
PEDESTRIAN INDICATORS - IN PLACE	(14)
PEDESTRIAN PUSH BUTTONS ON PEDESTAL OR POLE	(15)
PEDESTRIAN PUSH BUTTON STATION	(16)
TRAFFIC SIGNAL PEDESTAL	(17)
TRAFFIC SIGNAL PEDESTAL - INPLACE	(18)
TRAFFIC SIGNAL POLE AND MAST ARM	(19)
TRAFFIC SIGNAL POLE AND MAST ARM - IN PLACE	(20)
STREET LIGHT POLE AND LUMINAIRE	(21)
STREET LIGHT POLE AND LUMINAIRE - IN PLACE	(22)
MAST ARM AND LUMINAIRE	(23)
MAST ARM AND LUMINAIRE - INPLACE	(24)
WOOD POLE	(25)
WOOD POLE - IN PLACE	(26)
SOURCE OF POWER	(27)
RAILROAD SIGNAL - IN PLACE	(28)
RIGHT OF WAY LINE	(29)
CENTERLINE	(30)
EDGE OF ROADWAY	(31)
SHOULDERLINE	(32)
CURB LINE	(33)
STOP BAR	(34)

**CONDUCTOR COLOR CODE**

R	RED
O	ORANGE
BL	BLUE
WH	WHITE
R/BLK	RED WITH BLACK TRACER
O/BLK	ORANGE WITH BLACK TRACER
BL/BLK	BLUE WITH BLACK TRACER
WH/BLK	WHITE WITH BLACK TRACER
BLK	BLACK
BLK/WH	BLACK WITH WHITE TRACER
G/BLK	GREEN WITH BLACK TRACER
G	GREEN

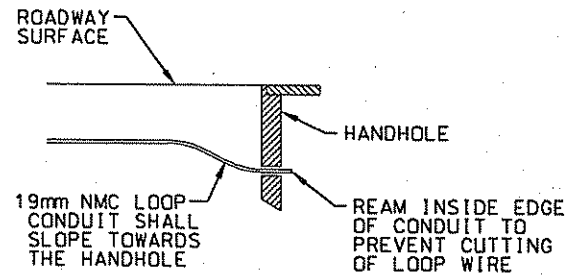

**DRAINAGE DETAIL**

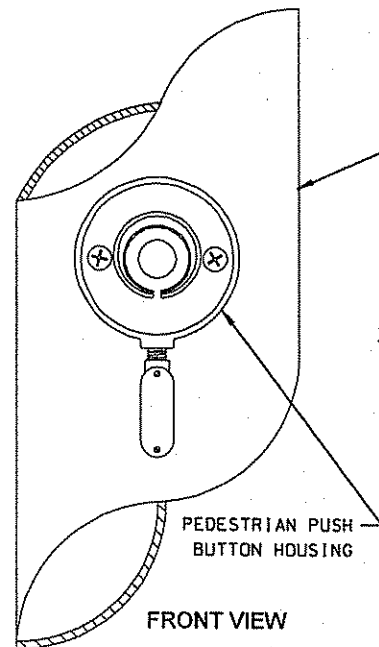

**FRONT VIEW**

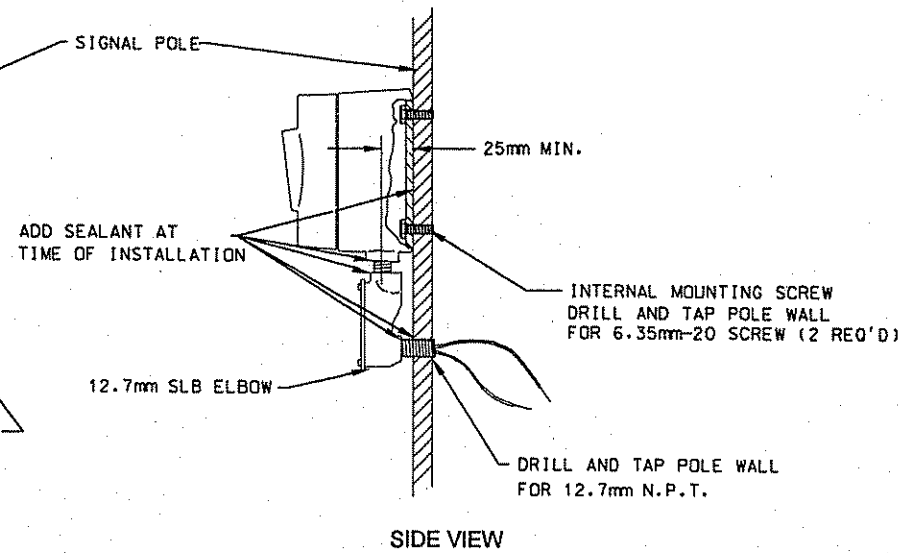

**SIDE VIEW**

**MAST ARM POLE PEDESTRIAN PUSH BUTTON DETAL**

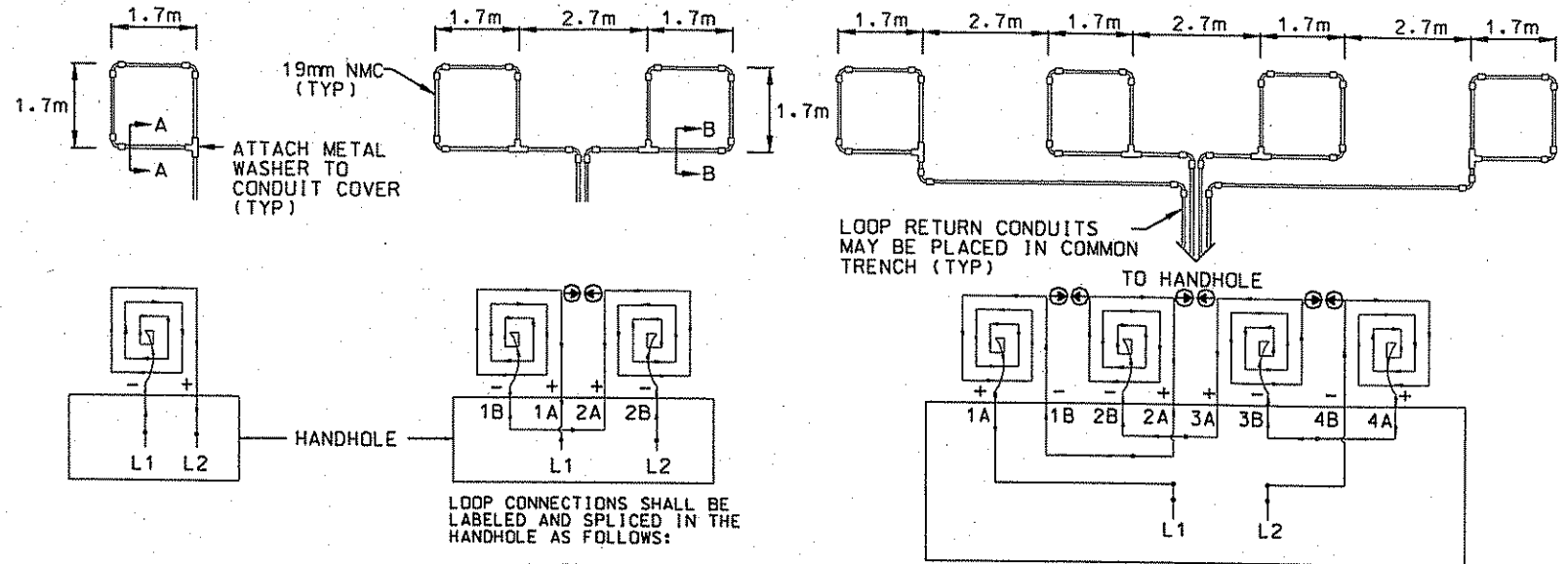

**LOOP DETECTOR DETAIL 'A'**  
(LOOP PHASING FOR SINGLE CONNECTION)

**LOOP DETECTOR DETAIL 'B'**  
(LOOP PHASING FOR SERIES CONNECTION)

**LOOP DETECTOR DETAIL 'C'**  
(LOOP PHASING FOR SERIES CONNECTION)

**LOOP DETECTOR WIRING**

- 1) ALL CORNERS SHALL BE 90° CONDUIT BENDS.
- 2) CONNECT WIRES IN HANDHOLES USING SPLICE KIT METHOD DESCRIBED IN THE SPECIAL PROVISIONS.
- 3) LOOP DETECTOR WIRES SHALL BE #12 AWG CROSSED LINKED POLYETHYLENE (XLP). SEE SPECIAL PROVISIONS.
- 4) LOOP LEAD IN WIRES SHALL BE TWISTED A MIN. OF (5) TURNS PER FOOT THROUGH THE CONDUIT TO THE HANDHOLE.
- 5) NMC DESIGNATES NON-METALLIC CONDUIT (SPEC. 3803)
- 6) LOOPS 1.7m x 1.7m THRU 1.7m x 4.2m SHALL HAVE (4) TURNS.
- 7) LOOPS 1.7m x 4.6m AND LARGER SHALL HAVE (2) TURNS.

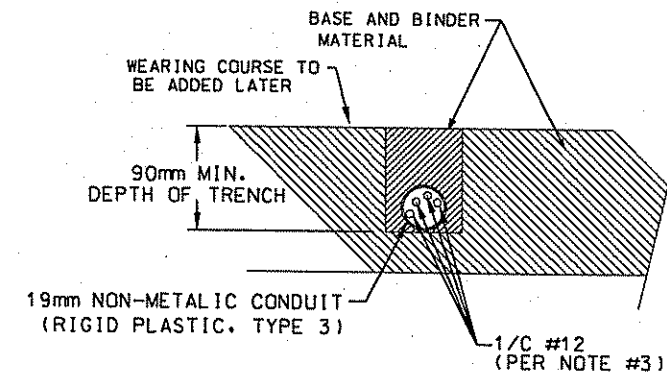

**SECTION A-A**  
DETAIL FOR LOOP INSTALLATION IN NEW ROADWAY

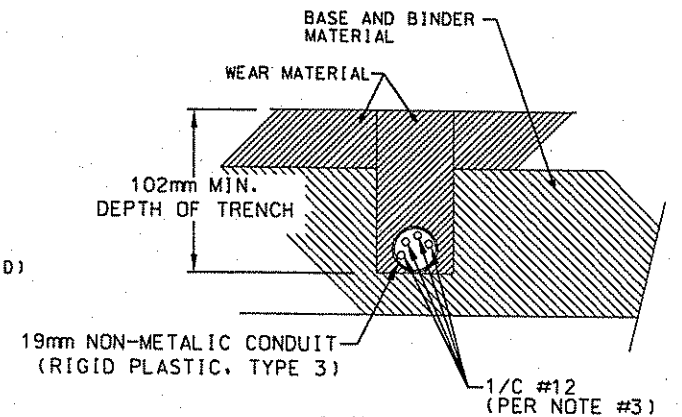

**SECTION B-B**  
DETAIL FOR LOOP INSTALLATION IN EXISTING ROADWAY

**STANDARD PLATES**

THESE STANDARD PLATES AS APPROVED BY FHWA SHALL APPLY:

PLATE NO.	DESCRIPTION
* M8110 D	TRAFFIC SIGNAL BRACKETING - POLE MOUNTED
M8111 C	TRAFFIC SIGNAL BRACKETING - PEDESTAL MOUNTED
M8112 C	PEDESTAL FOUNDATION
* M8130 D	SAW CUT LOOP DETECTORS
* M8115 D	PEDESTRIAN PUSH BUTTON INSTALLATION
* M8114 A	P.V.C. HANDHOLE/PULL BOX
M8118 C	SERVICE EQUIPMENT AND POLE
* M8119 C	GROUND MOUNTED CABINET FOUNDATION
* M8126 F	PA90 AND PA100 POLE FOUNDATION
* M8121 D	TRANSFORMER BASE WITH POLE BASE
M8122 C	PEDESTAL AND PEDESTAL BASE
* M8123 D	POLE AND MAST ARM
* M8124 E	MAST ARM SIGNAL HEAD MOUNTS
M8120 K	PA85 POLE FOUNDATION
M3124 B	METAL APRON CONNECTION
M3221 C	CORRUGATED STEEL PIPE COUPLING BAND
* M7035 J	CONCRETE WALK AND CURB RETURNS AT ENTRANCES
* M7100 G	CONCRETE CURB AND GUTTERS
* M7036 D	PEDESTRIAN CURB RAMP

\* - APPLIES TO THIS PROJECT

S.P. 02-601-39, S.P. 114-106-03  
S.P. 02-678-14

TRAFFIC SIGNAL DETAILS

SHEET 32 OF 40 SHEETS

CSAH 1 (Coon Rapids Blvd)  
at CSAH 78 (Hanson Blvd)  
Anoka County, Minnesota



350 Westwood Lake Office  
8441 Wayzata Boulevard  
Minneapolis, MN 55426  
612-541-4800  
FAX 641-1700



INFRASTRUCTURE - ENGINEERS - PLANNERS

HEREBY CERTIFY THAT THIS PLAN, SPECIFICATION OR REPORT WAS PREPARED BY OR UNDER MY DIRECT SUPERVISION AND THAT I AM A DULY LICENSED PROFESSIONAL ENGINEER UNDER THE LAWS OF THE STATE OF MINNESOTA.  
DATE: 5/28/99 REG. NO. 26092

I:\1044.00\1044.01\cvt\1044.dwg

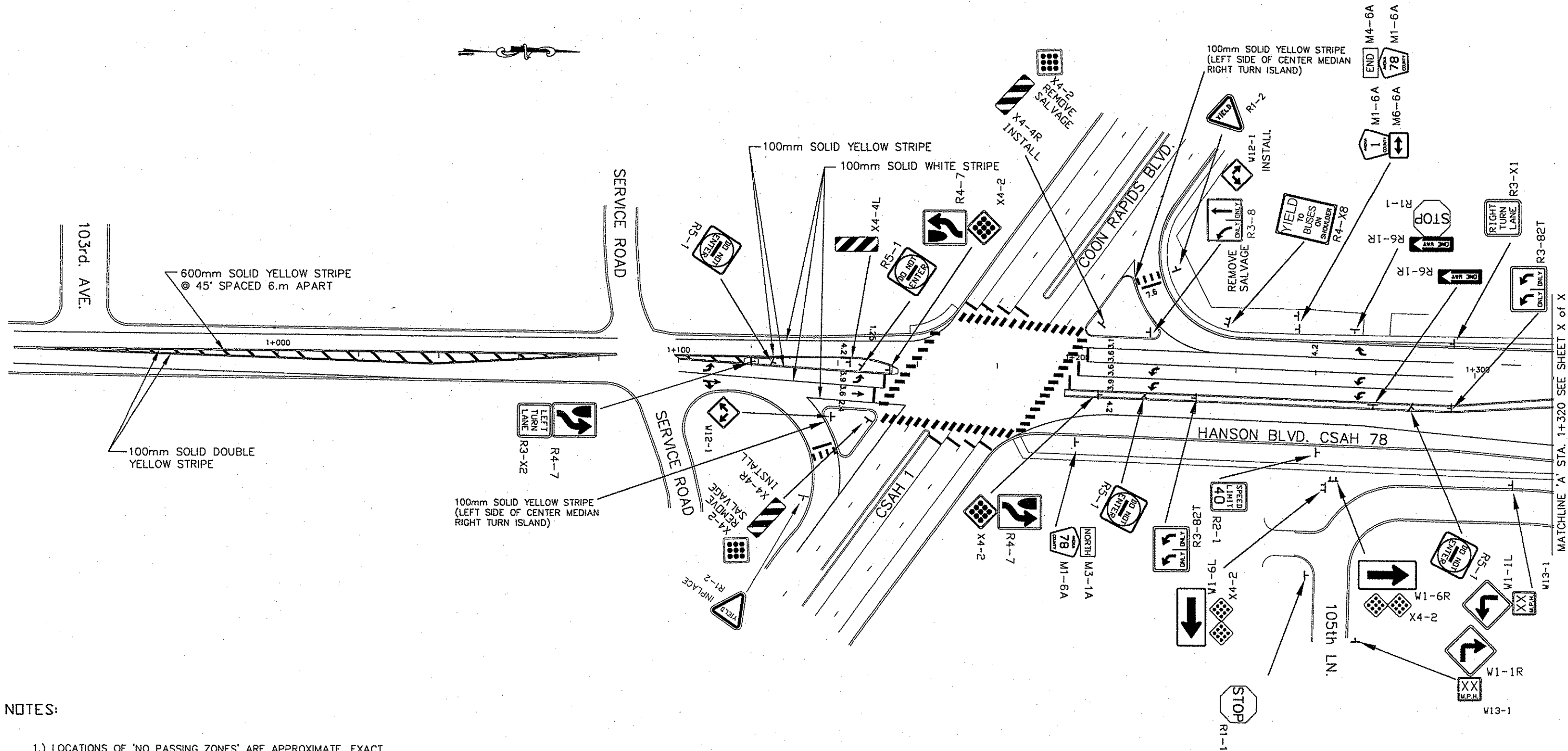

**NOTES:**

- 1.) LOCATIONS OF 'NO PASSING ZONES' ARE APPROXIMATE. EXACT LOCATIONS WILL BE DETERMINED IN THE FIELD.
- 2.) ALL TRAFFIC CONTROL DEVICES SHALL CONFORM THE MOST RECENT EDITION OF THE MINNESOTA MANUAL ON UNIFORM TRAFFIC CONTROL DEVICES, INCLUDING THE FIELD MANUAL DATED JANUARY 1998.

NO	DATE	BY	CHKD	APPR	REVISION



I HEREBY CERTIFY THAT THIS PLAN WAS PREPARED BY ME OR UNDER MY DIRECT SUPERVISION AND THAT I AM A DULY REGISTERED PROFESSIONAL ENGINEER UNDER THE LAWS OF THE STATE OF MINNESOTA.

*[Signature]*

DATE 07/09/99 REG. NO. 25066

DRAWN BY D.M. DATE 3/98  
 DESIGN BY D.M. DATE 3/98  
 CHECKED BY J.P. DATE 3/98

**ANOKA COUNTY**  
**HIGHWAY DEPT.**

STATE PROJECT NO. 02-601-39  
 STATE PROJECT NO. 02-678-14  
 STATE PROJECT NO. 114-106-03  
 STATE PROJECT NO. 114-020-21

**PERMANENT**

**SIGNING AND STRIPING PLAN**

Sheet 33 of 40 Sheets

MATCHLINE 'A' STA. 1+320 SEE SHEET X of X

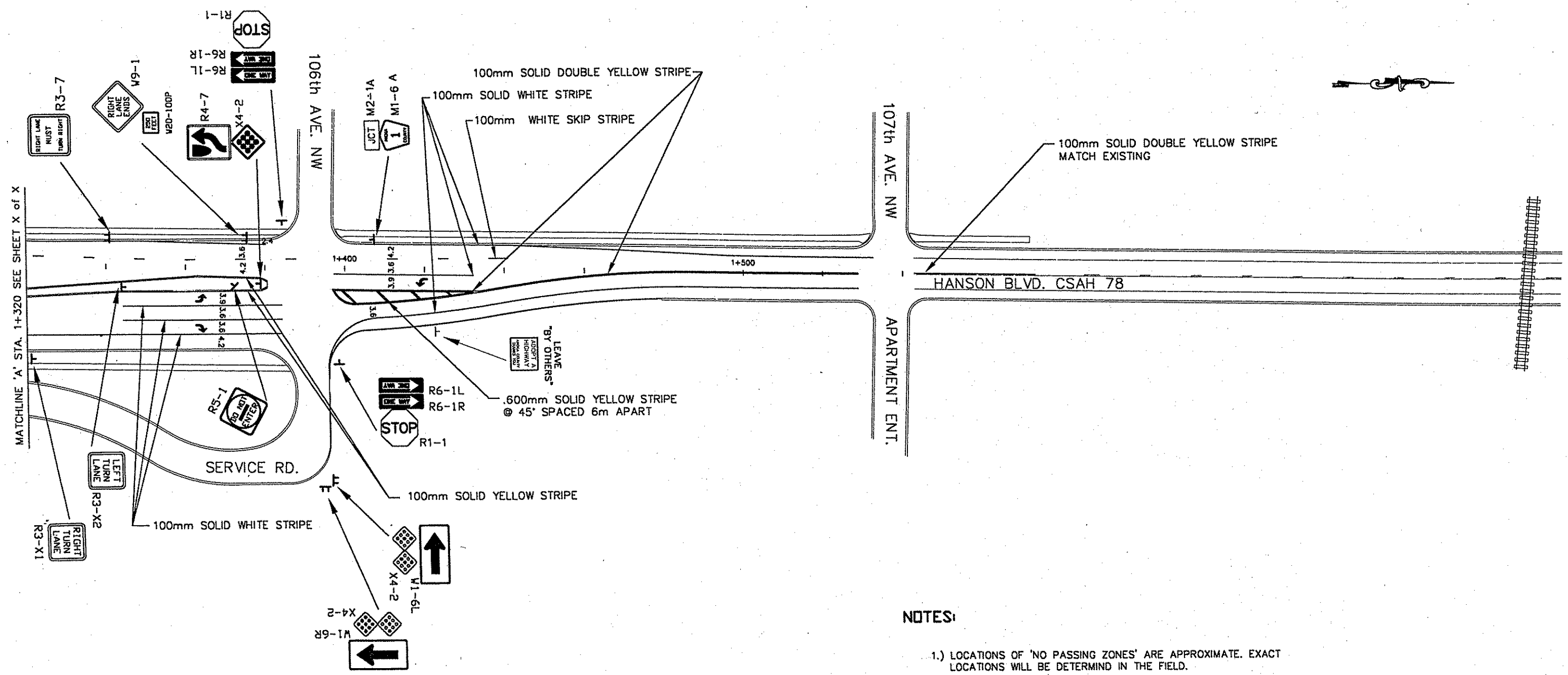

**NOTES:**

- 1.) LOCATIONS OF 'NO PASSING ZONES' ARE APPROXIMATE. EXACT LOCATIONS WILL BE DETERMINED IN THE FIELD.
- 2.) ALL TRAFFIC CONTROL DEVICES SHALL CONFORM THE MOST RECENT EDITION OF THE MINNESOTA MANUAL ON UNIFORM TRAFFIC CONTROL DEVICES, INCLUDING THE FIELD MANUAL DATED JANUARY 1998.

**PERMANENT**

NO.	DATE	BY	CHKD	APPR	REVISION

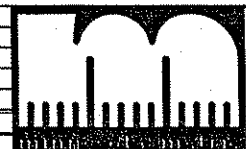

I HEREBY CERTIFY THAT THIS PLAN WAS PREPARED BY ME OR UNDER MY DIRECT SUPERVISION AND THAT I AM A DULY REGISTERED PROFESSIONAL ENGINEER UNDER THE LAWS OF THE STATE OF MINNESOTA.

*Albert*

DATE 07/09/99 REG. NO. 25086

DRAWN BY D.M. DATE 3/98  
 DESIGN BY D.M. DATE 3/98  
 CHECKED BY J.P. DATE 3/98



**ANOKA COUNTY  
 HIGHWAY DEPT.**

STATE PROJECT NO. 02-601-39  
 STATE PROJECT NO. 02-678-14  
 STATE PROJECT NO. 114-106-03  
 STATE PROJECT NO. 114-020-21

**SIGNING AND STRIPING PLAN**

Sheet 34 of 40 Sheets

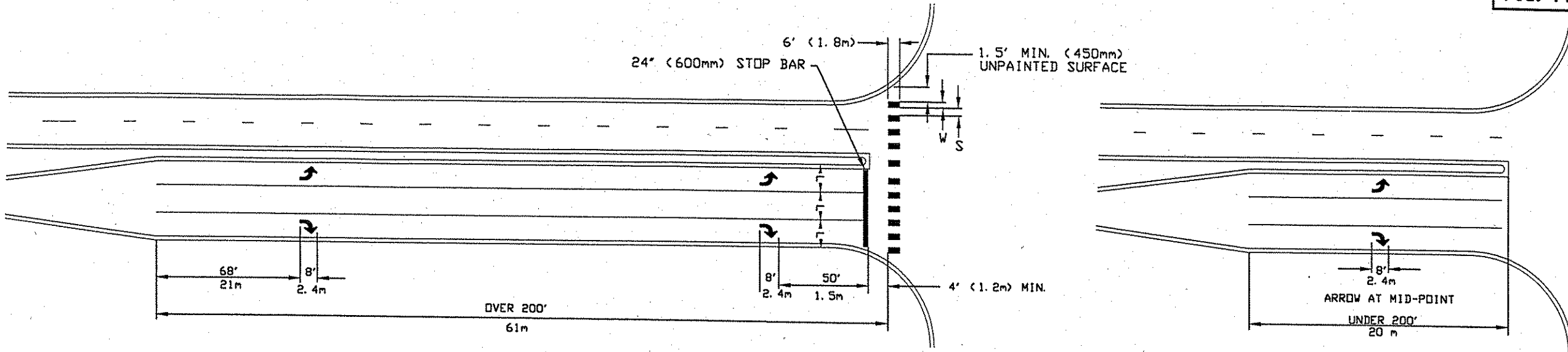

( L )	( W )	( S )
WIDTH OF INSIDE LANE	WIDTH OF PAINTED AREAS	WIDTH OF SPACE
9'	2.0'	2.5'
10'	2.5'	2.5'
11'	2.5'	3.0'
12'	3.0'	3.0'
13'	3.0'	3.5'

( L )	( W )	( S )
WIDTH OF INSIDE LANE	WIDTH OF PAINTED AREAS	WIDTH OF SPACE
2.7m	600mm	750mm
3.0m	750mm	750mm
3.3m	750mm	900mm
3.6m	900mm	900mm
4.0m	900mm	1100mm

- NOTES: CROSSWALKS**
- 1.) PAINTED AREAS ARE TO BE CENTERED ON CENTER AND LANE LINES, EVEN IF INTERSECTION IS NOT ALIGNED.
  - 2.) LOCATION OF ZEBRA CROSSWALKS AND STOP BARS, SIGNAL LOOPS AND PED RAMP ARE APPROXIMATE. FINAL LOCATIONS ARE TO BE DETERMINED AND FIELD VERIFIED DURING CONSTRUCTION BY THE FIELD ENGR.
  - 3.) ZEBRA CROSSWALKS ARE TO BE PARALLEL TO THE DRIVING LANE OR LANES, EVEN IF THE STREET IS ON AN ANGLE TO THE INTERSECTION.
  - 4.) A MIN. OF 1.5' (450mm) CLEAR DISTANCE MUST BE LEFT ADJACENT TO THE CURB. IF LAST PAINTED AREA FALLS INTO THIS AREA, IT MUST BE OMITTED.
  - 5.) ON TWO LANE STREETS, USE SPACING SHOWN FOR AN 11' (3.3m) INSIDE LANE.

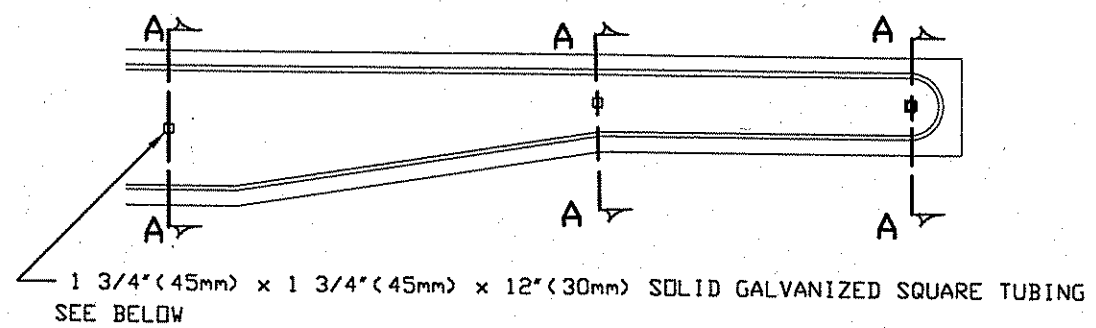

**GROUND POST MOUNT SIGN  
INSTALLATION TYPICAL**

**ISLAND MOUNT BREAK-AWAY SIGN  
INSTALLATION TYPICAL**

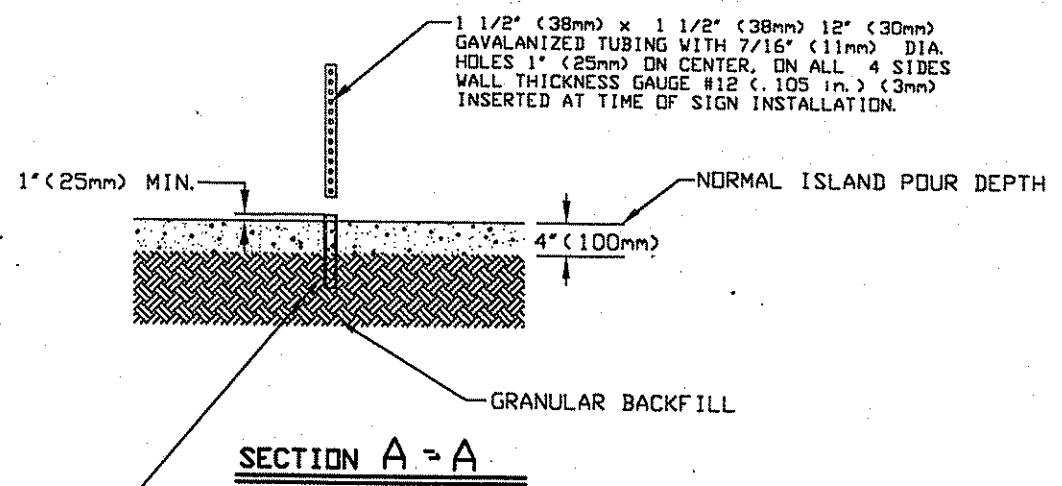
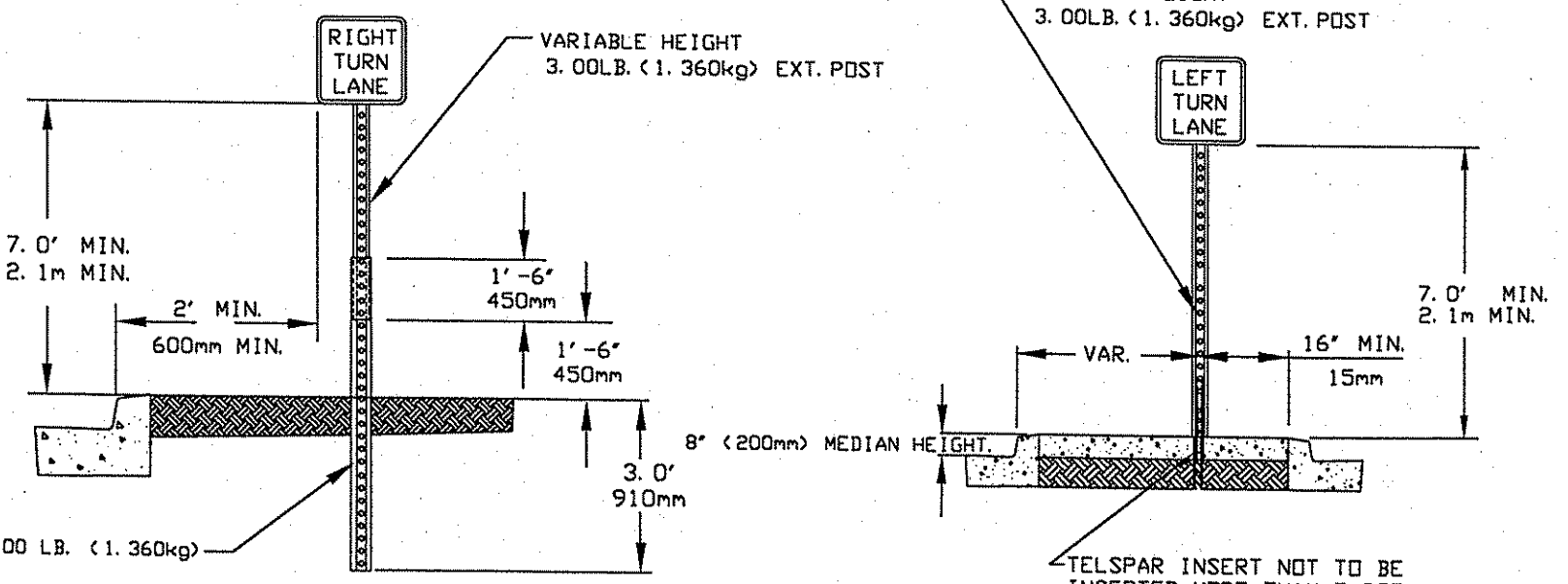

INSTALL 1 3/4" (45mm) x 1 3/4" (45mm) x 12" (25mm) SOLID WALL GALVANIZED SQUARE TUBING BEFORE CONCRETE POUR. HAMMER INTO GROUND SO THAT 1" (25mm) OF TUBE IS ABOVE GROUND. RE-PLUMB AT TIME OF POUR.

TELSPAR INSERT NOT TO BE INSERTED MORE THAN THREE MOUNTING HOLES DEEP INTO FOOTING, TYP. ON ALL SIGN INSTALLATIONS.

**SIGNING DETAILS**

NO	DATE	BY	CHKD	APPR	REVISION



I HEREBY CERTIFY THAT THIS PLAN WAS PREPARED BY ME OR UNDER MY DIRECT SUPERVISION AND THAT I AM A DULY REGISTERED PROFESSIONAL ENGINEER UNDER THE LAWS OF THE STATE OF MINNESOTA.

*Albert*

DATE 07/09/98 REG. NO. 25066

DRAWN BY D.M. DATE 3/98  
 DESIGN BY D.M. DATE 3/98  
 CHECKED BY J.P. DATE 3/98



**ANOKA COUNTY  
HIGHWAY DEPT.**

STATE PROJECT NO. 02-601-39  
 STATE PROJECT NO. 02-678-14  
 STATE PROJECT NO. 114-106-03  
 STATE PROJECT NO. 114-020-21

**SIGNING AND STRIPING PLAN**

Sheet 35 of 40 Sheets

K U T.C. & CODE	SIZE		PANEL AREA		INSERT	QTY	MOUNTING POST PER INSTALLATION		MOUNTING HEIGHT
	INCHES	mm	FT <sup>2</sup>	m <sup>2</sup>			FT.	m	
R1-1	30" x 30"	762mm X 762mm	6.25	0.575	STOP	4	1	7.0'	2.1
R1-2	36" x 36"	914mm X 914mm	4.50	0.414	YIELD	1	1	7.0'	2.1
R2-4	24" x 30"	610mm X 760mm	5.00	0.460	SPEED LIMIT 40	1	1	7.0'	2.1
R3-X1	30" x 30"	762mm X 762mm	6.25	0.575	RIGHT TURN LANE	2	1	7.0'	2.1
R3-X2	30" x 30"	762mm X 762mm	6.25	0.575	LEFT TURN LANE	2	1	7.0'	2.1
R3-7R	30" x 30"	762mm X 762mm	6.25	0.575	RIGHT LANE MUST TURN RIGHT	1	1	7.0'	2.1
R3-8F	36" x 30"	914mm X 762mm	7.50	0.690	ONLY ONLY	2	1	7.0'	2.1
R4-7	24" x 30"	610mm X 760mm	5.00	0.460		4	1	7.0'	2.1
X4-2	18" x 18"	455mm X 455mm	2.25	0.207		4			
R4-XB	36" x 48"	914mm X 1219mm	12.00	1.104	YIELD TO BUSES ON SHOULDER	1	1	7.0'	2.1
R5-1	30" x 30"	762mm X 762mm	6.25	0.575	DO NOT ENTER	5	1	7.0'	2.1
R6-1R	36" x 12"	914mm X 304mm	3.00	0.267	ONE WAY	4	1	7.0'	2.1
R6-1L	36" x 12"	914mm X 304mm	3.00	0.267	ONE WAY	2			
W1-1R	30" x 30"	762mm X 762mm	6.25	0.575		1	2	7.0'	2.1
W13-1	24" x 24"	610mm X 610mm	4.00	0.368	XX M.P.M.	1			

K U T.C. & CODE	SIZE		PANEL AREA		INSERT	QTY	MOUNTING POST PER INSTALLATION		MOUNTING HEIGHT
	INCHES	mm	FT <sup>2</sup>	m <sup>2</sup>			FT.	m	
W1-1L	30" x 30"	762mm X 762mm	6.25	0.575		1	2	7.0'	2.1
W13-1	24" x 24"	610mm X 610mm	4.00	0.368	XX M.P.M.	1			
W1-6R	48" x 24"	914mm X 304mm	8.00	0.736		2	2	7.0'	2.1
X4-2	18" x 18"	457mm X 304mm	2.25	0.207		2			
W1-6L	48" x 24"	1.219mm X 609mm	8.00	0.736		2	2	7.0'	2.1
X4-2	18" x 18"	457mm X 457mm	2.25	0.207		2			
W9-1	36" x 36"	914mm X 914mm	9.00	0.836	RIGHT LANE ENDS	1	2	7.0'	2.1
W20-100P	24" x 18"	609mm X 457mm	2.25	0.207	250 FEET	1			
W12-1	24" x 24"	610mm X 610mm	4.00	0.368		2	1	4.0'	1.2
X4-4R	12" x 36"	304mm X 914mm	3.00	0.276		2	1	4.0'	1.2
X4-4L	12" x 36"	304mm X 914mm	3.00	0.276		1	1	4.0'	1.2
M2-1A	21" x 15"	530mm X 380mm	2.18	0.200	JCT	1			
M1-6A	24" x 24"	610mm X 610mm	4.00	0.368	ANOKA 1 COUNTY	2	1	7.0'	2.1
M6-4A	21" x 15"	530mm X 380mm	2.18	0.200		1			
M4-6A	24" x 12"	610mm X 305mm	2.00	0.180	END	1			
M3-1A	24" x 12"	610mm X 305mm	2.00	0.180	NORTH	1			
M1-6A	24" x 24"	610mm X 610mm	4.00	0.368	ANOKA 78 COUNTY	2			

- NOTE
- ① 2- R6-1R MOUNTED ABOVE R1-1
  - ② 2- R6-1L MOUNTED ABOVE R1-1
  - ③ TO BE DETERMINED IN THE FIELD

NOTES:

- 1.) LOCATIONS OF 'NO PASSING ZONES' ARE APPROXIMATE. EXACT LOCATIONS WILL BE DETERMINED IN THE FIELD.
- 2.) ALL TRAFFIC CONTROL DEVICES SHALL CONFORM THE MOST RECENT EDITION OF THE MINNESOTA MANUAL ON UNIFORM TRAFFIC CONTROL DEVICES, INCLUDING THE FIELD MANUAL DATED JANUARY 1998.

SIGN QUANTITIES

NO	DATE	BY	CHK	APPR	REVISION

I HEREBY CERTIFY THAT THIS PLAN WAS PREPARED BY ME OR UNDER MY DIRECT SUPERVISION AND THAT I AM A DULY REGISTERED PROFESSIONAL ENGINEER UNDER THE NAME OF THE STATE OF MINNESOTA.

*Albert*  
DATE 07/08/99 REG. NO. 25066

DRAWN BY D.M. DATE 3/98  
 DESIGN BY D.M. DATE 3/98  
 CHECKED BY J.P. DATE 3/98



ANOKA COUNTY  
HIGHWAY DEPT.

STATE PROJECT NO. 02-601-39  
 STATE PROJECT NO. 02-678-14  
 STATE PROJECT NO. 114-106-03  
 STATE PROJECT NO. 114-020-21

SIGNING AND STRIPING PLAN  
 Sheet 36 of 40 Sheets

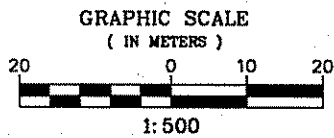
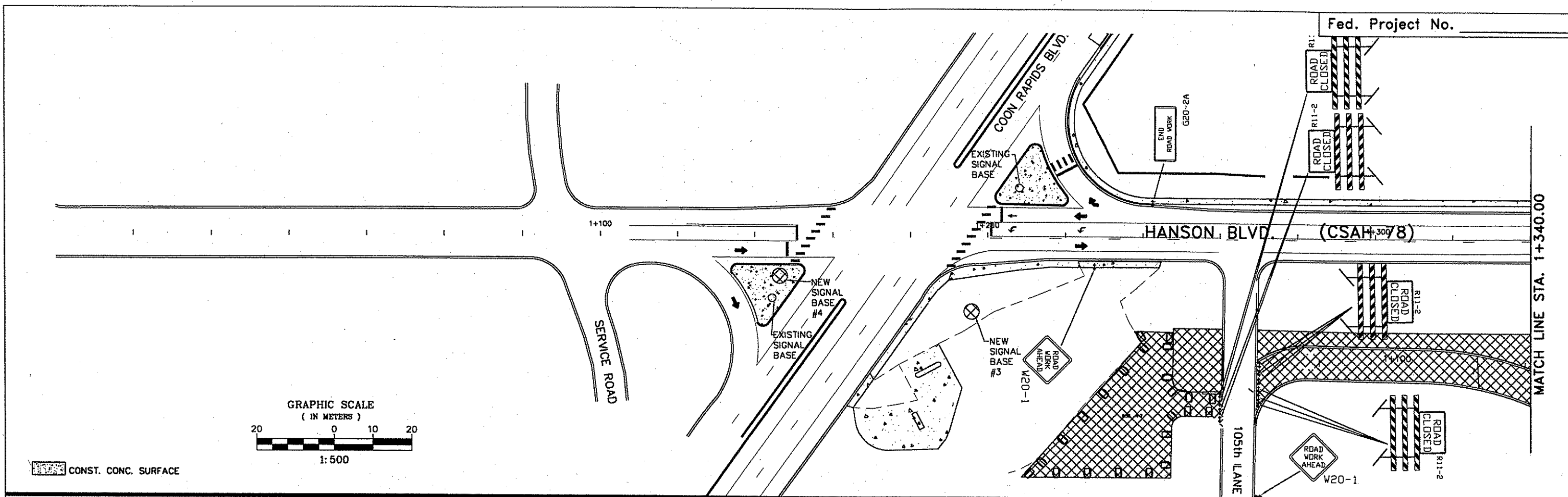

CONST. CONC. SURFACE

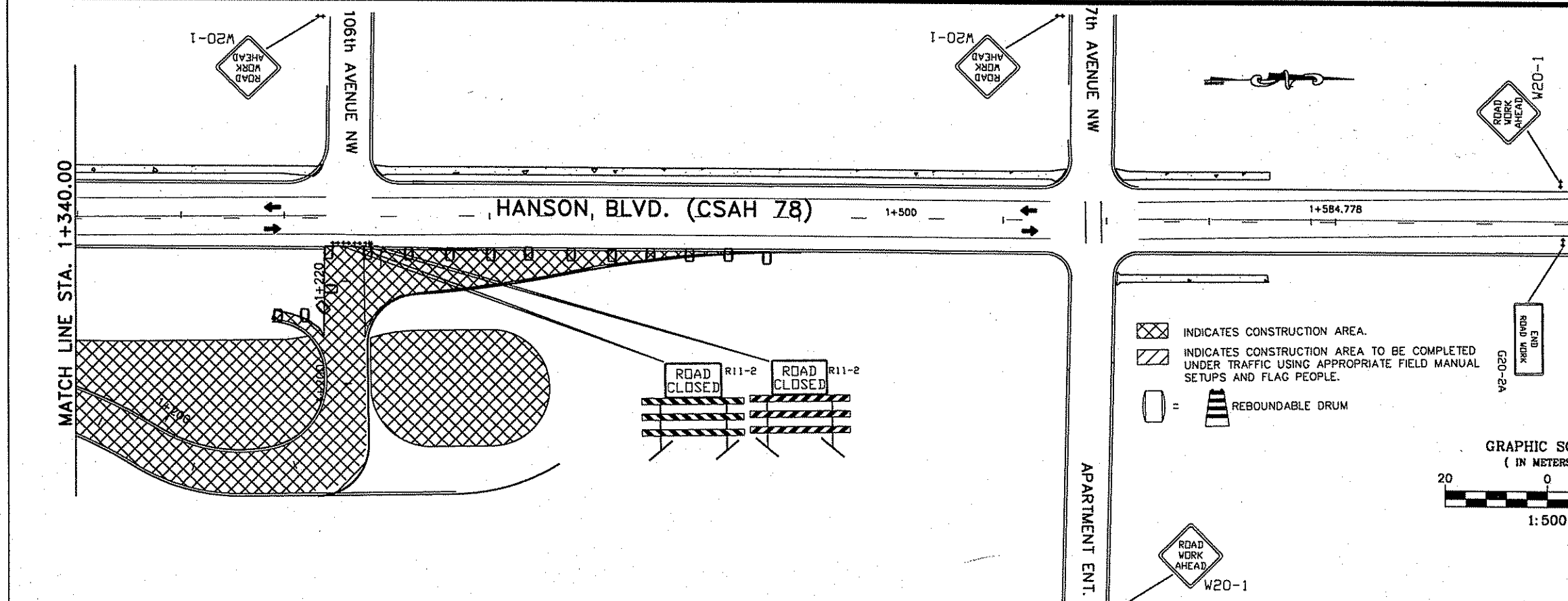

NOTES:

1. ALL TRAFFIC CONTROL DEVICES SHALL CONFORM TO THE MINNESOTA MANUAL ON UNIFORM TRAFFIC CONTROL DEVICES, INCLUDING THE FIELD MANUAL DATED JANUARY, 1998.
2. PAVEMENT MARKINGS IN ALL TAPER AREAS SHALL HAVE TEMPORARY RAISED PAVEMENT MARKERS AT 3m INTERVALS.
3. ALL TYPE III BARRICADES SHALL BE REFLECTORIZED ON BOTH SIDES, AND BARRICADE MARKINGS SHALL BE SLANTED IN ACCORDANCE WITH THE MINNESOTA MANUAL ON UNIFORM TRAFFIC CONTROL DEVICES.

TRAFFIC SIGNAL - STAGE I

INSTALL BASES #3 AND #4. INSTALL MAST ARM POLES, MAST ARMS, SIGNAL HEADS NORTHBOUND (#4), SIGNAL HEADS EASTBOUND (#6 AND #1), USE FREY TEMPORARY PLUMIZER MOUNT HARDWARE. USE EXISTING OR NEW SIGNAL CABLES AS NEEDED. REMOVE OLD MAST ARM POLES AND BASES #3 AND #4 AT TIME OF SWITCH OVER TO STAGE #2.

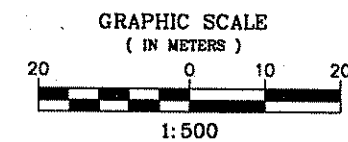

- INDICATES CONSTRUCTION AREA.
- INDICATES CONSTRUCTION AREA TO BE COMPLETED UNDER TRAFFIC USING APPROPRIATE FIELD MANUAL SETUPS AND FLAG PEOPLE.
- REBOUNDABLE DRUM

STAGE 1  
HANSON BLVD.  
C.S.A.H. 78

NO	DATE	BY	CKD	APPR	REVISION



I HEREBY CERTIFY THAT THIS PLAN WAS PREPARED BY ME OR UNDER MY DIRECT SUPERVISION AND THAT I AM A DULY REGISTERED PROFESSIONAL ENGINEER UNDER THE LAWS OF THE STATE OF MINNESOTA.

*Allyson B.*

DATE 07/09/99 REG. NO. 25066

DRAWN BY: RLB DATE: 4/21/99  
 DESGN BY: RDR DATE: 4/21/99  
 CHECKED BY: JKP DATE: 4/21/99

**ANOKA COUNTY**  
**HIGHWAY DEPT.**

STATE PROJECT NO. 02-601-39  
 STATE PROJECT NO. 02-678-14  
 STATE PROJECT NO. 114-106-03  
 STATE PROJECT NO. 114-020-21

**CONSTRUCTION STAGING PLAN**

Sheet 37 of 40 Sheets

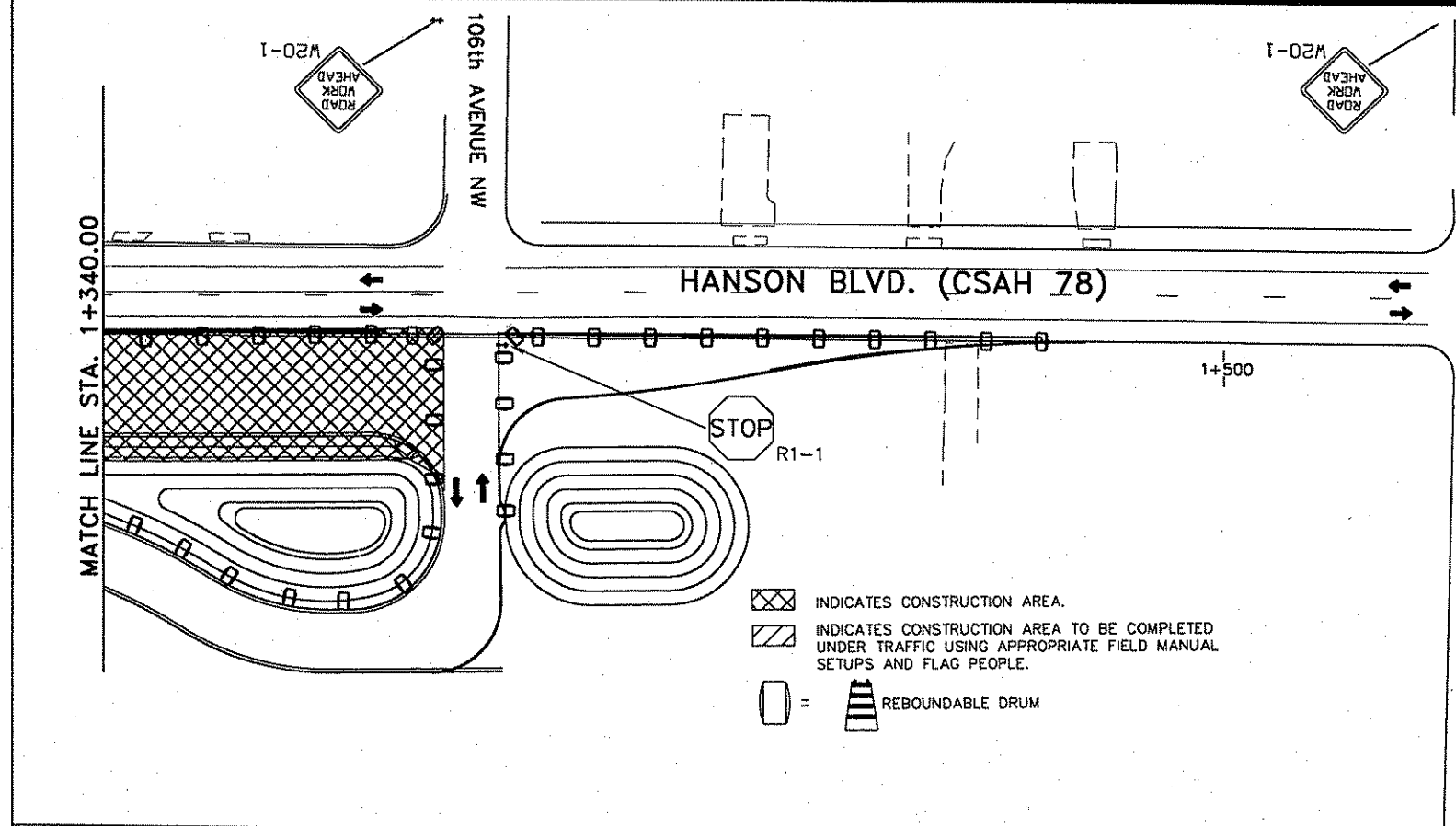
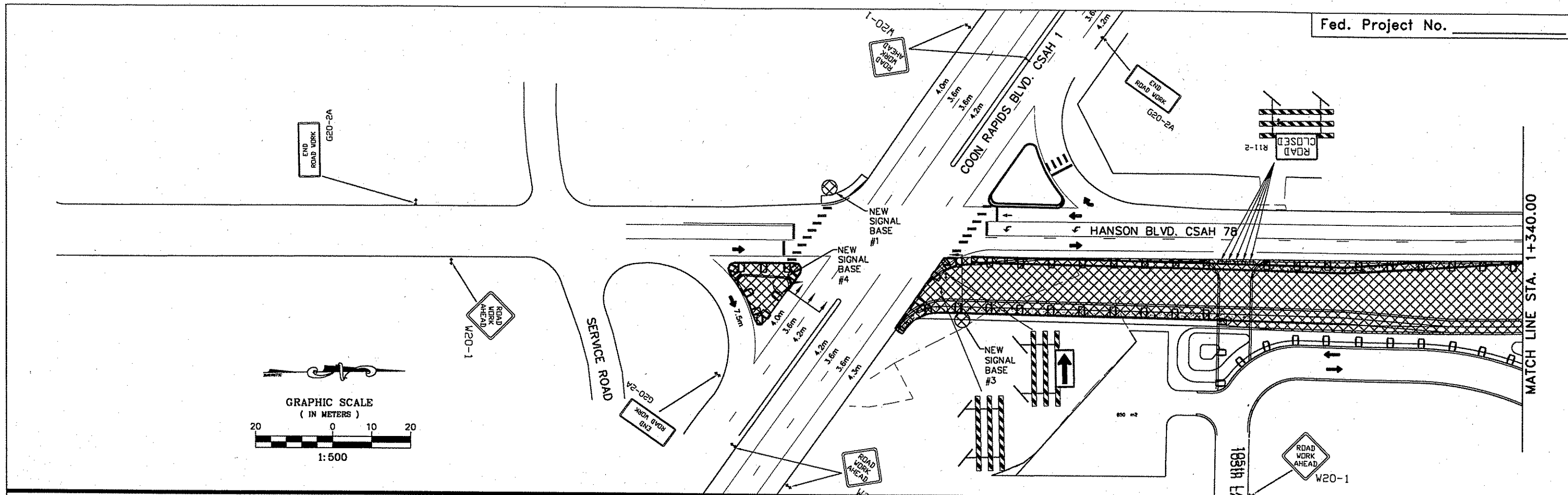

**NOTES:**

1. ALL TRAFFIC CONTROL DEVICES SHALL CONFORM TO THE MINNESOTA MANUAL ON UNIFORM TRAFFIC CONTROL DEVICES, INCLUDING THE FIELD MANUAL DATED JANUARY, 1998.
2. PAVEMENT MARKINGS IN ALL TAPER AREAS SHALL HAVE TEMPORARY RAISED PAVEMENT MARKERS AT 3m INTERVALS.
3. ALL TYPE III BARRICADES SHALL BE REFLECTORIZED ON BOTH SIDES, AND BARRICADE MARKINGS SHALL BE SLANTED IN ACCORDANCE WITH THE MINNESOTA MANUAL ON UNIFORM TRAFFIC CONTROL DEVICES.
4. DAYTIME LANE CLOSURES FOR NB/SB CSAH 1 8:30AM-3:30PM, USE APPROPRIATE LAYOUT IN THE FIELD MANUAL DATED JANUARY 1998.

TRAFFIC SIGNAL - STAGE 2  
 RUN SPAN WIRE CABLE FROM BASE #1 TO BASE #4. INSTALL Ø4 SIGNAL HEADS USING SPAN MOUNT HARDWARE. USE TEMPORARY CABLES FOR WIRING SPAN MOUNT HEADS ALL AT TIME OF SWITCH OVER TO STAGE #3. INSTALL NEW CONTROLLER CABINET AND SERVICE CABINET FOUNDATIONS.

**LEGEND:**

- INDICATES CONSTRUCTION AREA.
- INDICATES CONSTRUCTION AREA TO BE COMPLETED UNDER TRAFFIC USING APPROPRIATE FIELD MANUAL SETUPS AND FLAG PEOPLE.
- REBOUNDABLE DRUM

**GRAPHIC SCALE (IN METERS)**  
 1:500

**STAGE 2  
 HANSON BLVD.  
 C.S.A.H. 78**

NO	DATE	BY	CKD	APPR	REVISION

NAME: MN 26-STAGE2.dwg 9-14-99

I HEREBY CERTIFY THAT THIS PLAN WAS PREPARED BY ME OR UNDER MY DIRECT SUPERVISION AND THAT I AM A DULY REGISTERED PROFESSIONAL ENGINEER UNDER THE LAWS OF THE STATE OF MINNESOTA.

*[Signature]*  
 DATE 07/09/99 REG. NO. 25066

DRAWN BY: RLB DATE 4/21/99  
 DESIGN BY: RDB DATE 4/21/99  
 CHECKED BY: JKP DATE 4/21/99

**ANOKA COUNTY  
 HIGHWAY DEPT.**

STATE PROJECT NO. 02-601-39  
 STATE PROJECT NO. 02-678-14  
 STATE PROJECT NO. 114-106-03  
 STATE PROJECT NO. 114-020-21

**CONSTRUCTION  
 STAGING PLAN**

Sheet 38 of 40 Sheets

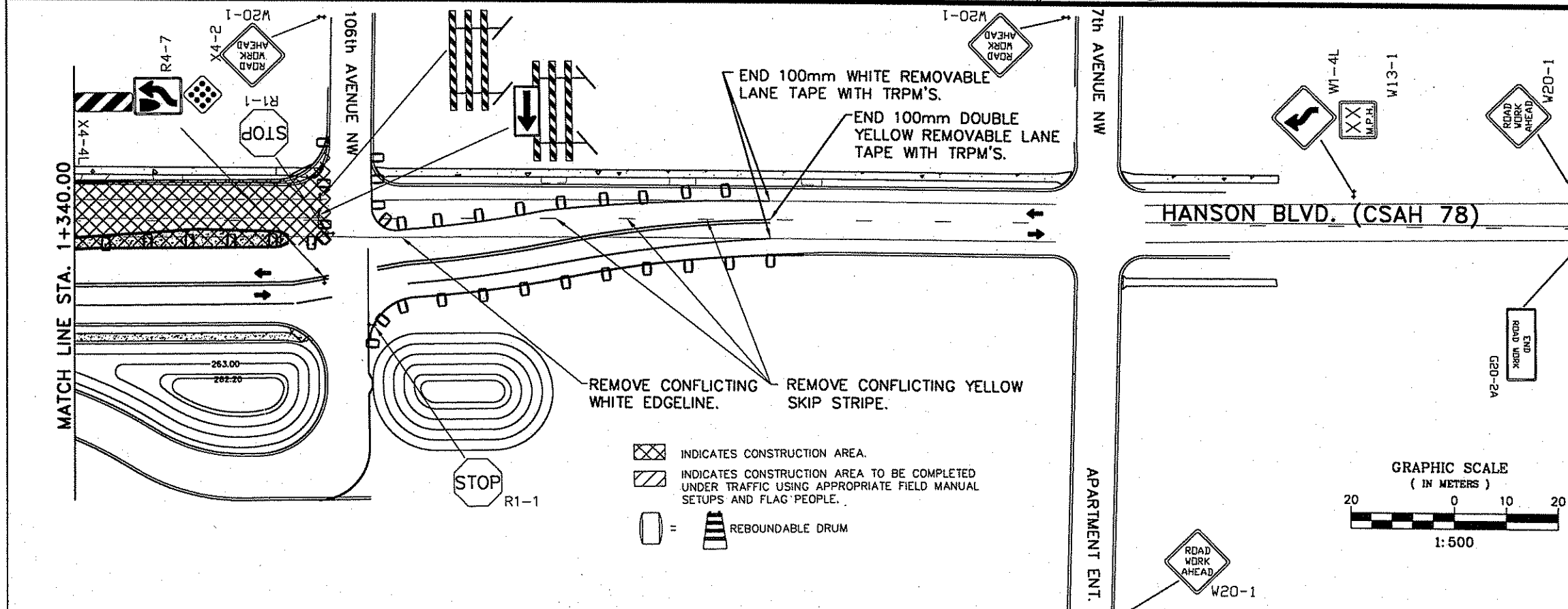
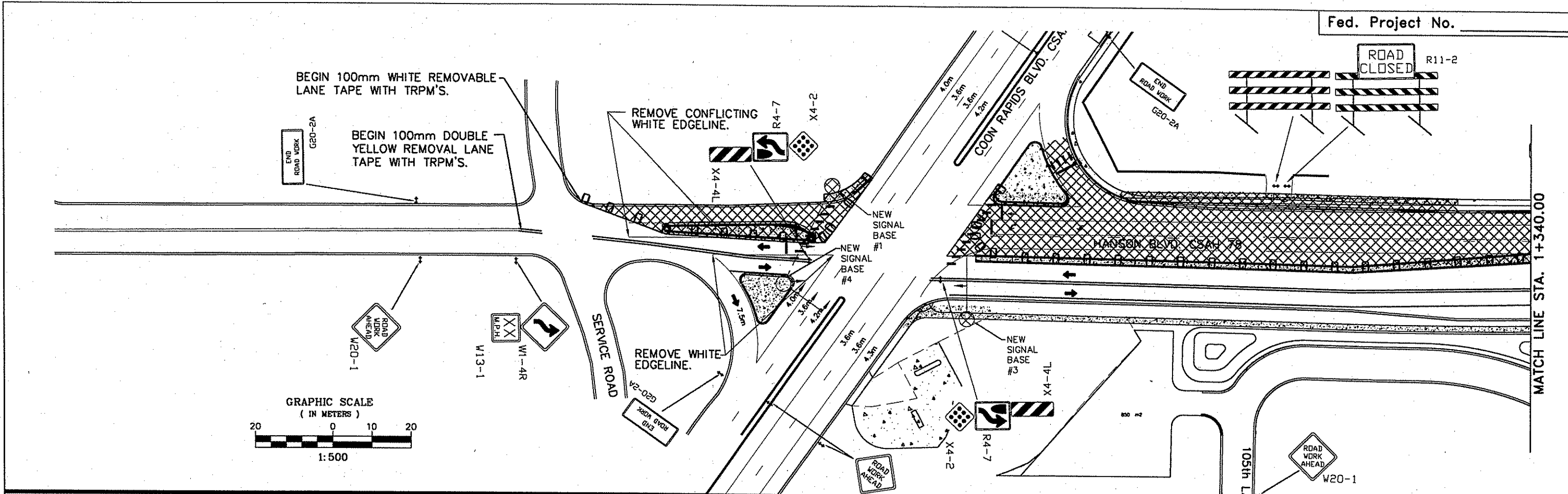

**NOTES:**

1. ALL TRAFFIC CONTROL DEVICES SHALL CONFORM TO THE MINNESOTA MANUAL ON UNIFORM TRAFFIC CONTROL DEVICES, INCLUDING THE FIELD MANUAL DATED JANUARY, 1998.
2. PAVEMENT MARKINGS IN ALL TAPER AREAS SHALL HAVE TEMPORARY RAISED PAVEMENT MARKERS AT 3m INTERVALS.
3. ALL TYPE III BARRICADES SHALL BE REFLECTORIZED ON BOTH SIDES, AND BARRICADE MARKINGS SHALL BE SLANTED IN ACCORDANCE WITH THE MINNESOTA MANUAL ON UNIFORM TRAFFIC CONTROL DEVICES.

TRAFFIC SIGNAL - STAGE 3  
 REPOSITION #4 SIGNAL HEAD FOR CONSTRUCTION TRAFFIC. (SPAN MOUNT AND PLUMIZER MOUNT). REMOVE #4 SOUTHBOUND HEAD FROM OLD SYSTEM. FINISH INSTALLING MAST ARMS, BASES, ETC.. SWITCH OVER TO NEW CONTROLLER CABINET AND SYSTEM AT END OF STAGE 3 FOR FINAL SWITCH OVER TO NEW TRAFFIC SIGNAL SYSTEM.

- INDICATES CONSTRUCTION AREA.
- INDICATES CONSTRUCTION AREA TO BE COMPLETED UNDER TRAFFIC USING APPROPRIATE FIELD MANUAL SETUPS AND FLAG PEOPLE.
- REBOUNDABLE DRUM

NO	DATE	BY	CKD	APPR	REVISION

I HEREBY CERTIFY THAT THIS PLAN WAS PREPARED BY ME OR UNDER MY DIRECT SUPERVISION AND THAT I AM A DULY REGISTERED PROFESSIONAL ENGINEER UNDER THE LAWS OF THE STATE OF MINNESOTA.

*Albert*

DATE 07/09/99 REG. NO. 25066

DRAWN BY: RLR DATE: 4/21/99  
 DESIGN BY: RDR DATE: 4/21/99  
 CHECKED BY: JKP DATE: 4/21/99

**ANOKA COUNTY HIGHWAY DEPT.**

STATE PROJECT NO. 02-601-39  
 STATE PROJECT NO. 02-678-14  
 STATE PROJECT NO. 114-106-03  
 STATE PROJECT NO. 114-020-21

**CONSTRUCTION STAGING PLAN**

Sheet 39 of 40 Sheets



M. U. T. C. D. CODE	SIZE	INSERT	STAGE I	STAGE II	STAGE III
			QTY	QTY	QTY
R4-7A	24" x 30"		0	0	3
X4-2	18" x 18"		0	0	3
W1-6L	48" x 24"		0	1	1
TYPE III	8 FT.		7	2	3
R11-2	48" x 24"		6	2	1
TYPE III	8 FT.		7	5	1
W1-4R	48" x 48"		0	0	1
W13-1	30" x 30"		0	0	1
W1-4L	48" x 48"		0	0	1
W13-1	30" x 30"		0	0	1
W20-1	48" x 48"		6	10	10
G20-2A	48" x 24"		2	4	4
REBOUNDABLE DRUM REFLECTORIZED			39	89	71
R1-1	48" x 48"		0	1	2
X4-4L	12" x 36"		0	0	3

QUANTITIES - LANE TAPE, PAINT AND TRPMS  
INSTALL

STAGE	100mm PAINT				100mm REMOVAL LANE TAPE				TRPMS	
	YELLOW	WHITE	DBL YELLOW	YELLOW SKIP	YELLOW	WHITE	DBL YELLOW	YELLOW SKIP	WHITE	YELLOW
1	0	0	0	0	0	0	0	0	0	0
2	0	0	0	0	0	0	0	0	0	0
3	0	0	0	0	0	635	345	0	212	424
TOTAL	0	0	0	0	0	635	345	0	212	424

REMOVAL

STAGE	100mm PAINT				610mm PAINT	
	YELLOW	WHITE	DBL YELLOW	YELLOW SKIP	YELLOW	WHITE
1	0	0	0	0	0	0
2	0	0	0	0	0	0
3	0	70	0	10	0	0
TOTAL	0	70	0	10	0	0

NOTES:

1. ALL TRAFFIC CONTROL DEVICES SHALL CONFORM TO THE MINNESOTA MANUAL ON UNIFORM TRAFFIC CONTROL DEVICES, INCLUDING THE FIELD MANUAL DATED JANUARY, 1998.
2. PAVEMENT MARKINGS IN ALL TAPER AREAS SHALL HAVE TEMPORARY RAISED PAVEMENT MARKERS AT 3m INTERVALS.
3. ALL TYPE III BARRICADES SHALL BE REFLECTORIZED ON BOTH SIDES, AND BARRICADE MARKINGS SHALL BE SLANTED IN ACCORDANCE WITH THE MINNESOTA MANUAL ON UNIFORM TRAFFIC CONTROL DEVICES.

STAGE QUANTITIES

NO	DATE	BY	CHKD	APPR	REVISION

I HEREBY CERTIFY THAT THIS PLAN WAS PREPARED BY ME OR UNDER MY DIRECT SUPERVISION AND THAT I AM A DULY REGISTERED PROFESSIONAL ENGINEER UNDER THE LAWS OF THE STATE OF MINNESOTA.

*Allyson B.*  
DATE 07/09/99 REG. NO. 25066

DRAWN BY: RLB DATE 4/15/99  
DESIGN BY: RDB DATE 4/15/99  
CHECKED BY: JKP DATE 4/15/99

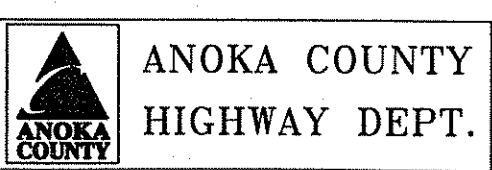

STATE PROJECT NO. 02-601-39  
STATE PROJECT NO. 02-678-14  
STATE PROJECT NO. 114-106-03  
STATE PROJECT NO. 114-020-21

TRAFFIC CONTROL PLAN  
Sheet 40 of 40 Sheets