

# MINNESOTA DEPARTMENT OF TRANSPORTATION ANOKA COUNTY

## CONSTRUCTION PLAN FOR GRADING, BITUMINOUS SURFACING, ADA IMPROVEMENTS AND SIGNAL REVISIONS

LOCATED ON C.S.A.H. 116 BETWEEN BUCHANAN STREET AND T.H. 65  
 LOCATED ON TH 65 AT CSAH 116 AND BUNKER LAKE BLVD

STATE AID PROJ. NO. 002-716-013 STATE PROJ. NO. 0208-145  
C.S.A.H. 116 T.H. 65

<table border="0"> <tr><td>GROSS LENGTH</td><td>1332.38 FEET</td><td>0.252 MILES</td></tr> <tr><td>BRIDGES-LENGTH</td><td>0.00 FEET</td><td>0.000 MILES</td></tr> <tr><td>EXCEPTIONS-LENGTH</td><td>0.00 FEET</td><td>0.000 MILES</td></tr> <tr><td>NET LENGTH</td><td>1332.38 FEET</td><td>0.252 MILES</td></tr> </table>	GROSS LENGTH	1332.38 FEET	0.252 MILES	BRIDGES-LENGTH	0.00 FEET	0.000 MILES	EXCEPTIONS-LENGTH	0.00 FEET	0.000 MILES	NET LENGTH	1332.38 FEET	0.252 MILES	<table border="0"> <tr><td>GROSS LENGTH</td><td>1621.00 FEET</td><td>0.307 MILES</td></tr> <tr><td>BRIDGES-LENGTH</td><td>0.00 FEET</td><td>0.000 MILES</td></tr> <tr><td>EXCEPTIONS-LENGTH</td><td>0.00 FEET</td><td>0.000 MILES</td></tr> <tr><td>NET LENGTH</td><td>1621.00 FEET</td><td>0.307 MILES</td></tr> </table>	GROSS LENGTH	1621.00 FEET	0.307 MILES	BRIDGES-LENGTH	0.00 FEET	0.000 MILES	EXCEPTIONS-LENGTH	0.00 FEET	0.000 MILES	NET LENGTH	1621.00 FEET	0.307 MILES
GROSS LENGTH	1332.38 FEET	0.252 MILES																							
BRIDGES-LENGTH	0.00 FEET	0.000 MILES																							
EXCEPTIONS-LENGTH	0.00 FEET	0.000 MILES																							
NET LENGTH	1332.38 FEET	0.252 MILES																							
GROSS LENGTH	1621.00 FEET	0.307 MILES																							
BRIDGES-LENGTH	0.00 FEET	0.000 MILES																							
EXCEPTIONS-LENGTH	0.00 FEET	0.000 MILES																							
NET LENGTH	1621.00 FEET	0.307 MILES																							

REF PT 16+00.749 TO REF PT 17+00.056

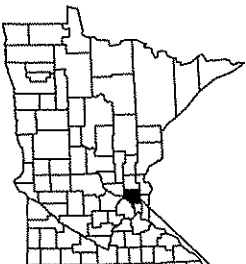
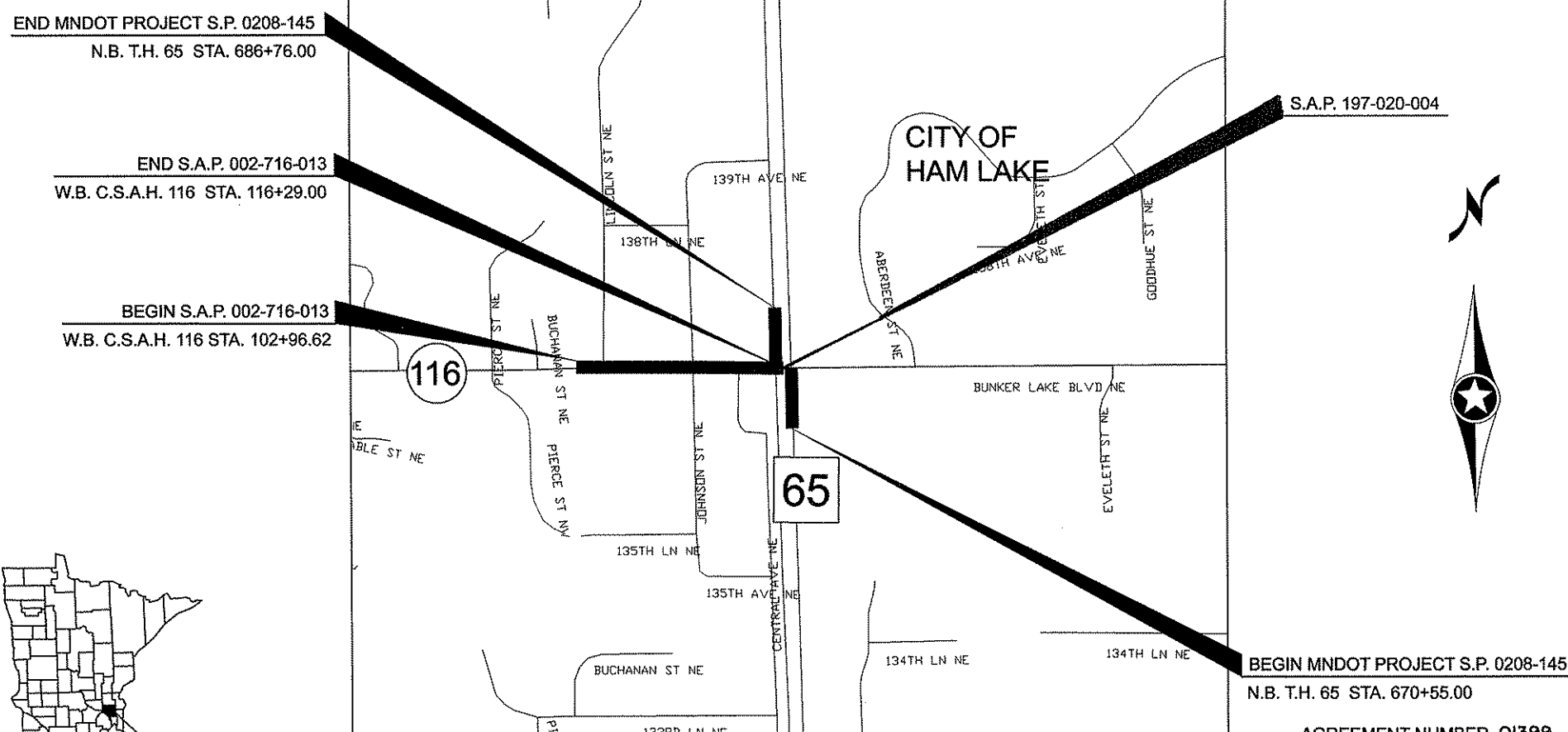

**PROJECT LOCATION**  
 CITY OF HAM LAKE  
 ANOKA COUNTY  
 MN/DOT TRANSPORTATION DISTRICT - METRO  
 SECTION 32  
 TOWNSHIP 32 NORTH  
 RANGE 23 WEST

DESIGN DESIGNATION (CSAH 116)		Functional Classification	
ESAL 20	1,618,736	MINOR ARTERIAL	
R VALUE	40	No. of Traffic Lanes	4
ADT (2012) =	11,228	No. of Parking Lanes	0
Proj. ADT (2032) =	15,900	Design Speed	50 MPH
Proj. HCADT (2032) =	954	Based on Stopping Sight Distance	N/A
Soil Factor	NA	Height of eye	3.5'
10 TON DESIGN		Height of object	2.0'
		Design Speed not achieved at:	
		STA. _____ TO STA. _____	MPH _____

AGREEMENT NUMBER 01399  
 ANOKA COUNTY  
 S.P. 0208-145 (TH 65 = 005)  
 STATE FUNDS  
 METRO DISTRICT

**PLAN SYMBOLS**

- COUNTY LINE
- TOWNSHIP OR RANGE LINE
- SECTION LINE
- QUARTER LINE
- SIXTEENTH LINE
- RIGHT OF WAY LINE
- SLOPE EASEMENT
- EXISTING RIGHT OF WAY
- PROPERTY LINE
- CORPORATE OR CITY LIMITS
- RETAINING WALL
- RAILROAD
- RAILROAD RIGHT OF WAY
- RIVER OR CREEK
- DRAINAGE DITCH
- CULVERT
- DROP INLET
- GUARD RAIL
- BARBED WIRE FENCE
- WOVEN WIRE FENCE
- CHAIN LINK FENCE
- WOOD FENCE
- STONE WALL OR FENCE
- HEDGE

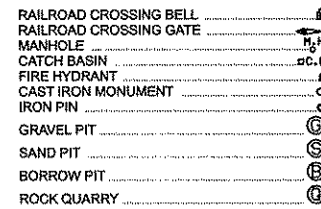
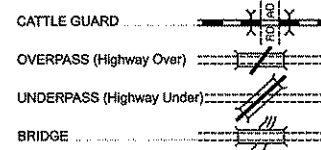

**UTILITY SYMBOLS**

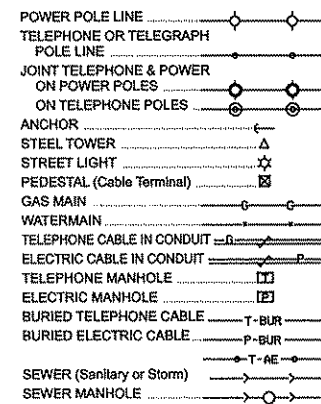

**SCALES**

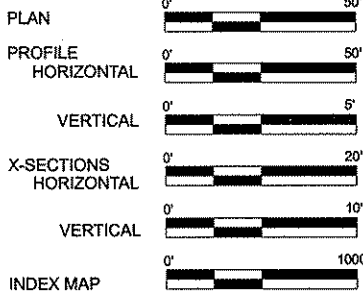

**GOVERNING SPECIFICATIONS**

THE 2005 EDITION OF THE MINNESOTA DEPARTMENT OF TRANSPORTATION "STANDARD SPECIFICATIONS FOR CONSTRUCTION" SHALL GOVERN. ALL TRAFFIC CONTROL DEVICES SHALL CONFORM AND BE INSTALLED IN ACCORDANCE TO THE "MINNESOTA MANUAL ON UNIFORM TRAFFIC CONTROL DEVICES" (MNMUTCD), AND PART VI, "FIELD MANUAL FOR TEMPORARY TRAFFIC CONTROL ZONE LAYOUTS."

**INDEX**

SHEET NO.	DESCRIPTION
1	TITLE SHEET
2 - 3	GENERAL LAYOUT
4	STATEMENT OF ESTIMATED QUANTITIES
5	SOILS AND CONSTRUCTION NOTES
6	EARTHWORK TABULATION
7	STANDARD PLATES, BASIS OF QUANTITIES
8 - 10	TABULATIONS
11 - 12	TYPICAL SECTIONS
13 - 17	PEDESTRIAN CURB RAMP DETAILS
18 - 20	INPLACE SIGNING AND STRIPING PLAN
21	MISCELLANEOUS DETAILS
22 - 27	CONSTRUCTION STAGING PLAN
28 - 42	TRAFFIC CONTROL PLAN
43 - 44	ALIGNMENT TABULATION AND PLAN
45 - 47	TOPOGRAPHY AND REMOVAL PLAN
48 - 52	CONSTRUCTION PLAN & PROFILE
53 - 55	DRAINAGE PLAN
56 - 58	INTERSECTION DETAILS
59 - 61	EXISTING UTILITY PLAN
62 - 63	SWPPP
64 - 73	SIGNING & STRIPING PLAN, TAB., & DETAILS
74 - 80	EROSION CONTROL PLAN AND DETAILS
81 - 90	TRAFFIC SIGNAL PLANS
91 - 108	CROSS SECTIONS

THIS PLAN CONTAINS 108 SHEETS

Approved: *[Signature]* 5/29/12  
 ANOKA COUNTY ENGINEER

Approved: *[Signature]* 5/30/12  
 CITY OF HAM LAKE ENGINEER

Recommended for Approval: *[Signature]* 6/14/12  
 DISTRICT TRANSPORTATION ENGINEER

Recommended for Approval: *[Signature]* 5/31/12  
 DISTRICT MATERIALS ENGINEER

Recommended for Approval: *[Signature]* 9/31/12  
 DISTRICT WATER RESOURCES/HYDRAULICS ENGINEER

Recommended for Approval: *[Signature]* 9/28/12  
 DISTRICT TRAFFIC ENGINEER

Recommended for Approval: *[Signature]* 9/28/12  
 STATE PRE-LETTING ENGINEER

Office of Land Management: *[Signature]* 6/11/12  
 APPROVAL: *[Signature]* 6/11/12  
 DIRECTOR, LAND MANAGEMENT

Approved: *[Signature]* 6/11/12  
 STATE DESIGN ENGINEER

Reviewed for Compliance With State Aid Rules/Policy: *[Signature]* 6/11/12  
 DISTRICT STATE AID ENGINEER

Approved for State Aid Funding: *[Signature]* 6/11/12  
 STATE AID ENGINEER

NO	DATE	BY	CHKD	APPR	REVISION
1	5/21/12	BAV	JEO	CAK	TEXT CHANGES

I HEREBY CERTIFY THAT THIS PLAN WAS PREPARED BY ME OR UNDER MY DIRECT SUPERVISION AND THAT I AM A DULY LICENSED PROFESSIONAL ENGINEER UNDER THE LAWS OF THE STATE OF MINNESOTA.

PRINT NAME: Curt Koblaresik  
 SIGNATURE: *[Signature]*  
 DATE: 5-29-12 LICENSE NO. 24756

DRAWN BY: BAV DATE: 3-23-12  
 DESIGN BY: BAV DATE: 3-23-12  
 CHECKED BY: JEO DATE: 4-10-12



**ANOKA COUNTY  
HIGHWAY DEPT.**

S.P. 0208-145 (T.H. 65 = 005)  
 S.A.P. 002-716-013  
 S.A.P. 197-020-004

**TITLE SHEET**  
 Sheet 1 of 108 Sheets

**LEGEND**

- XXX INPLACE TOPOGRAPHY AND REMOVAL PLAN SHEET NUMBER
- XXX CONSTRUCTION PLAN SHEET NUMBER
- XXX STORM DRAINAGE PLAN SHEET NUMBER
- REVISE SIGNAL SYSTEM

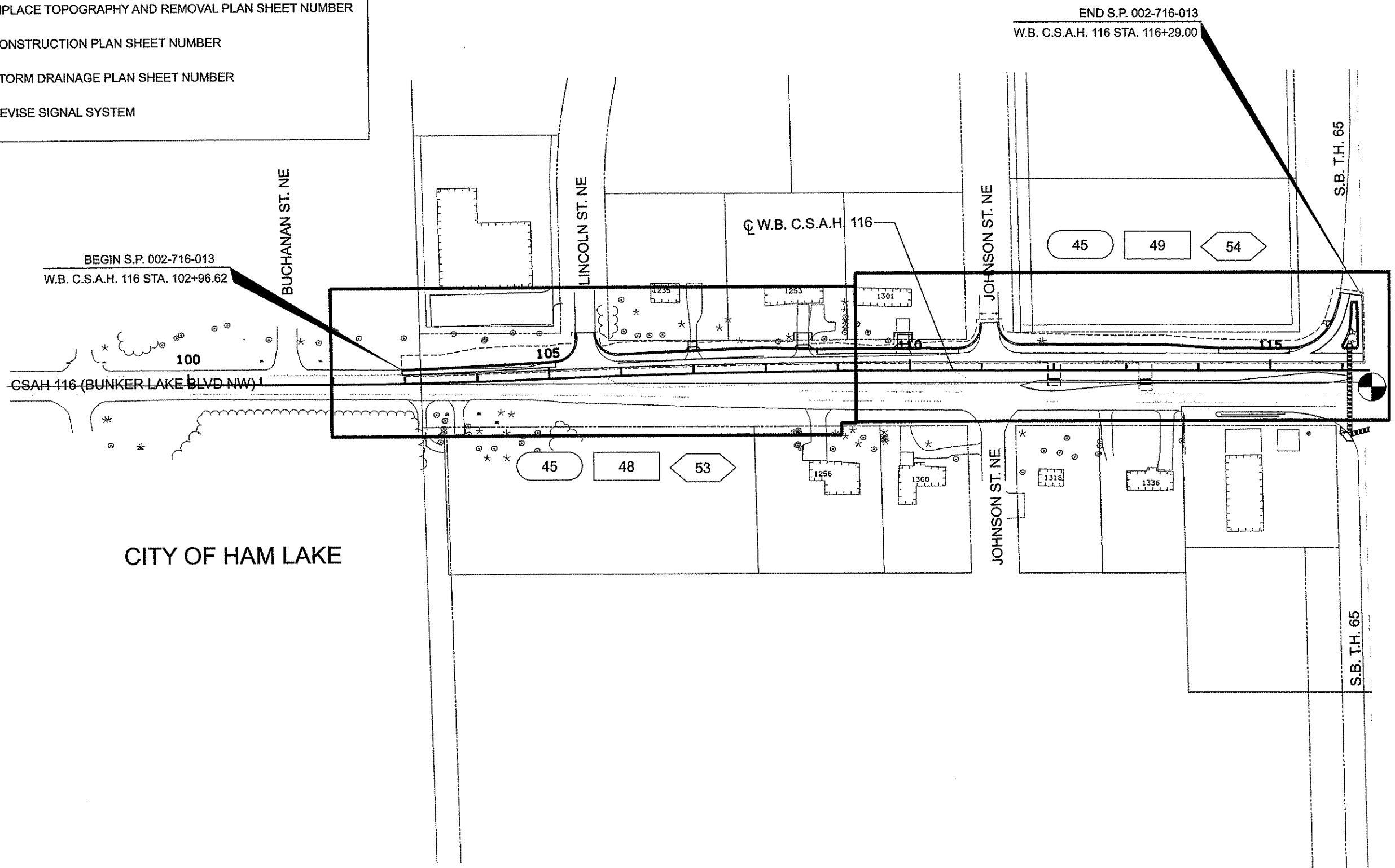

CITY OF HAM LAKE

1	5/21/12	BAV	JEO	CAK	TEXT CHANGES
NO	DATE	BY	CKD	APPR	REVISION
NAME: p1116-65\plan116-65_GL_P1.dgn		05/23/2012		9:43:11 AM	

I HEREBY CERTIFY THAT THIS PLAN WAS PREPARED BY ME OR UNDER MY DIRECT SUPERVISION AND THAT I AM A DULY LICENSED PROFESSIONAL ENGINEER UNDER THE LAWS OF THE STATE OF MINNESOTA.  
 PRINT NAME: Curt Kobilarcsik  
 SIGNATURE: *Curt Kobilarcsik*  
 DATE: 5-23-12 LICENSE NO. 24756

DRAWN BY: BAV DATE: 3-23-12  
 DESIGN BY: BAV DATE: 3-23-12  
 CHECKED BY: JEO DATE: 4-10-12

**ANOKA COUNTY**  
**HIGHWAY DEPT.**

S.P. 0208-145 (T.H. 65)  
 S.A.P. 002-716-013  
 S.A.P. 197-020-004

**LEGEND**

- XXX INPLACE TOPOGRAPHY AND REMOVAL PLAN SHEET NUMBER
- XXX CONSTRUCTION PLAN SHEET NUMBER
- XXX STORM DRAINAGE PLAN SHEET NUMBER
-  REVISE SIGNAL SYSTEM

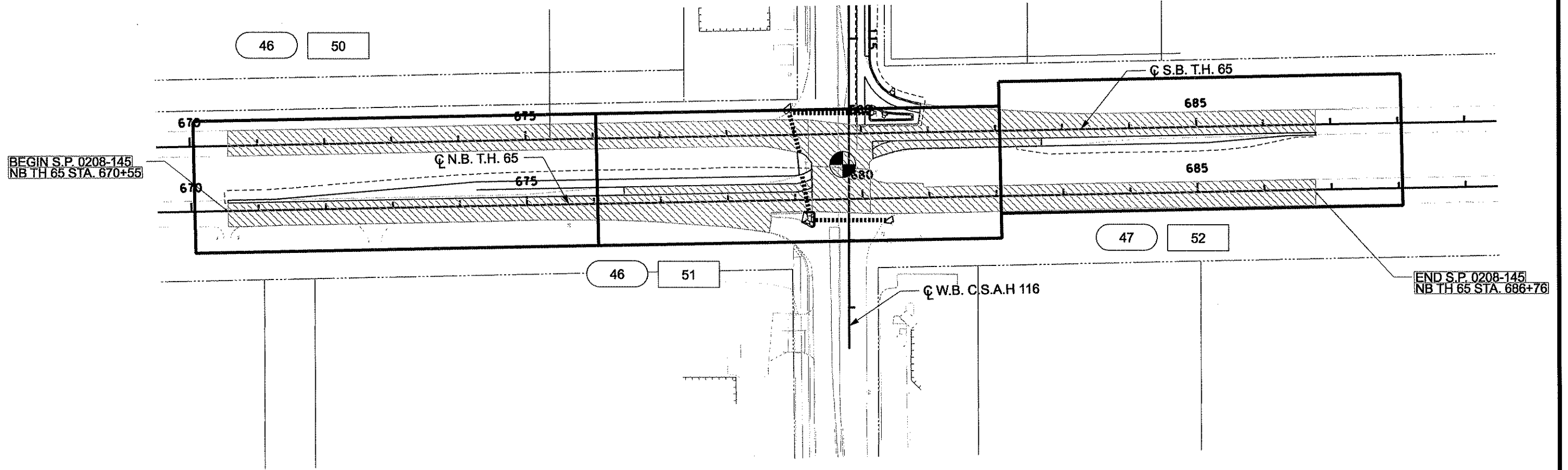

CITY OF HAM LAKE

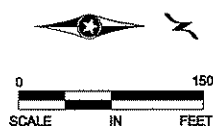

NO	DATE	BY	CHKD	APPR	REVISION
1	5/21/12	BAV	JEO	CAK	TEXT CHANGES
2	6/22/12	BAV	JEO	CAK	TEXT CHANGES
NAME: p:\116-65\plan\116-65_GL_P2.dgn					
DATE: 06/26/2012 11:40:54 AM					

I HEREBY CERTIFY THAT THIS PLAN WAS PREPARED BY ME OR UNDER MY DIRECT SUPERVISION AND THAT I AM A DULY LICENSED PROFESSIONAL ENGINEER UNDER THE LAWS OF THE STATE OF MINNESOTA.

PRINT NAME: Curt Koblarschik

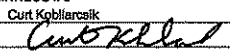
SIGNATURE: 

DATE: 6-27-12 LICENSE NO. 24758

DRAWN BY BAV DATE 3-23-12

DESIGN BY BAV DATE 3-23-12

CHECKED BY JEO DATE 4-10-12

 **ANOKA COUNTY  
HIGHWAY DEPT.**

S.P. 0208-145 (T.H. 65)  
S.A.P. 002-716-013  
S.A.P. 197-020-004

TAB / NOTE	ITEM NO.	ITEM DESCRIPTION	UNIT	TOTAL PROJECT QUANTITIES ESTIMATED	ANOKA COUNTY	STATE OF MINNESOTA
					SAP 002-716-013	SP 0208-145
				ROADWAY QUANTITIES ESTIMATED	ROADWAY QUANTITIES ESTIMATED	
	2021.501	MOBILIZATION	LUMP SUM	1	0.09	0.91
A	2101.502	CLEARING	TREE	4		4
A	2101.507	GRUBBING	TREE	4		4
	2102.502	PAVEMENT MARKING REMOVAL - PERMANENT	LIN FT	9274		9274
B	2104.501	REMOVE PIPE CULVERTS	LIN FT	24		24
B	2104.501	REMOVE PIPE SEWERS	LIN FT	304		304
B	2104.501	REMOVE CURB AND GUTTER	LIN FT	243		243
B	2104.503	REMOVE CONCRETE MEDIAN	SQ FT	973		973
B	2104.503	REMOVE BITUMINOUS PAVEMENT	SQ FT	31521		31521
B	2104.505	REMOVE CONCRETE SLAB	SQ YD	25		25
B	2104.509	REMOVE MANHOLE OR CATCH BASIN	EACH	1		1
B,3	2104.513	SAWING BITUMINOUS PAVEMENT (FULL DEPTH)	LIN FT	2861		2861
J	2104.523	SALVAGE CONCRETE APRON	EACH	1		1
1	2104.523	SALVAGE SIGN TYPE C	EACH	12	11	1
1	2104.601	HAUL SALVAGED MATERIAL	LUMP SUM	1	1	
D	2211.503	AGGREGATE BASE (CV) CLASS 5 (P)	CU YD	1006	159	847
I	2105.501	COMMON EXCAVATION (P)	CU YD	1717		1717
I	2105.507	SUBGRADE EXCAVATION	CU YD	1467		1467
I	2105.522	SELECT GRANULAR BORROW (CV)	CU YD	531		531
D	2221.503	AGGREGATE SHOULDERING (CV), CLASS 5	CU YD	24		24
E	2232.501	MILL BITUMINOUS SURFACE (2")	SQ YD	15001		15001
D	2357.502	BITUMINOUS MATERIAL FOR TACK COAT	GALLON	508	64	444
D	2360.501	TYPE SP 12.5 WEARING COURSE MIXTURE (2,B)	TON	3		3
D	2360.501	TYPE SP 12.5 WEARING COURSE MIXTURE (3,F)	TON	1164	144	1020
D	2360.501	TYPE SP 12.5 WEARING COURSE MIXTURE (4,F)	TON	1725		1725
D	2360.502	TYPE SP 12.5 NON WEARING COURSE MIXTURE (3,B)	TON	656	82	574
C	2411.507	CONCRETE FLUME	EACH	2		2
J	2501.573	INSTALL CONCRETE APRON	EACH	1		1
F, J	2503.541	15" RC PIPE SEWER DES 3006 CLV	LIN FT	492		492
F	2503.602	CONNECT TO EXISTING STORM SEWER	EACH	2		2
F	2506.501	CONST DRAINAGE STRUCTURE DESIGN H	LIN FT	15.5		15.5
F	2506.501	CONST DRAINAGE STRUCTURE DESIGN G	LIN FT	8.3		8.3
F	2506.501	CONST DRAINAGE STRUCTURE DESIGN 48-4020	LIN FT	15.9		15.9
F	2506.516	CASTING ASSEMBLY	EACH	13		13
J, 2	2511.501	RANDOM RIPRAP CLASS II	CU YD	14.9		14.9
F	2511.515	GEOTEXTILE FILTER TYPE III	SQ YD	48		48
C	2521.501	6" CONCRETE WALK	SQ FT	1732		1732
C	2531.501	CONCRETE CURB & GUTTER DESIGN B424	LIN FT	1644		1644
C,5	2531.501	CONCRETE CURB & GUTTER DESIGN B424 (MOD)	LIN FT	42		42
C	2531.507	6" CONCRETE DRIVEWAY PAVEMENT	SQ YD	40		40
C	2531.618	TRUNCATED DOMES	SQ FT	123		123
K	2533.507	PORTABLE PRECAST CONCRETE BARRIER DES 8337	LIN FT	1271		1271
K	2533.508	RELOCATE PRECAST CONCRETE BARRIER DES 8337	LIN FT	881		881
B	2540.602	RELOCATE MAILBOX SUPPORT	EACH	3		3
K	2554.615	IMPACT ATTENUATOR	AMBY	10		10
K	2554.615	RELOCATE IMPACT ATTENUATOR	AMBY	4		4
	2563.601	TRAFFIC CONTROL	LUMP SUM	1	0.09	0.91
	2564.531	SIGN PANELS TYPE C	SQ FT	67.8	60.3	7.5
	2564.536	INSTALL SIGN TYPE C	EACH	7	6	1
4	2565.616	REVISE SIGNAL SYSTEM	SIG SYS	1	0.25	0.50
G	2573.502	SILT FENCE, TYPE MACHINE SLICED	LIN FT	2187		2187
G	2573.530	STORM DRAIN INLET PROTECTION	EACH	14		14
G	2573.540	FILTER LOG TYPE ROCK LOG	LIN FT	112		112
G	2575.501	SEEDING	ACRE	0.8		0.8
G	2575.502	SEED MIXTURE 240	POUND	57		57
F, G	2575.505	SODDING TYPE SALT RESISTANT	SQ YD	676		676
G	2575.523	EROSION CONTROL BLANKETS CATEGORY 0	SQ YD	2247		2247
G	2575.532	FERTILIZER TYPE 3	POUND	268		268
G	2575.571	RAPID STABILIZATION METHOD 3	MGAL	4.6		4.6
II	2582.501	PAVEMENT MESSAGE (LT ARROW) PREFORMED THERMOPLASTIC	EACH	13		13
H	2582.501	PAVEMENT MESSAGE (RT ARROW) PREFORMED THERMOPLASTIC	EACH	7		7
II	2582.502	24" SOLID LINE WHITE - PREFORMED THERMOPLASTIC	LIN FT	51		51
II	2582.502	24" SOLID LINE YELLOW - PREFORMED THERMOPLASTIC	LIN FT	449		449
II	2582.502	4" SOLID LINE WHITE - EPOXY	LIN FT	12127		12127
II	2582.502	4" BROKEN LINE WHITE-EPOXY	LIN FT	1060		1060
H	2582.502	4" SOLID LINE YELLOW-EPOXY	LIN FT	5508		5508
II	2582.502	4" DOUBLE SOLID LINE YELLOW-EPOXY	LIN FT	1871		1871
H	2582.503	CROSSWALK MARKING - WHITE PREFORMED THERMOPLASTIC	SQ FT	1017		1017

NOTES:

- 1) THE DESIGNATED STORAGE AREA FOR SALVAGED SIGNS IS THE ANOKA COUNTY HIGHWAY DEPARTMENT SIGN SHOP, 1440 BUNKER LAKE BLVD., ANDOVER, MN 55304
- 2) RIPRAP QUANTITY INCLUDES 6 CU YD PER CONCRETE FLUME
- 3) SAWCUT IS ESTIMATED TO BE 6" DEEP
- 4) 50% STATE FUNDS, 25% SAP 002-716-013, 25% SAP 197-020-004
- 5) SEE SHEET 21

INDEX OF TABULATION CHARTS

TAB.	DESCRIPTION	SHEET NO.
A	CLEAR AND GRUB	8
B	REMOVALS, SAWING & RELOCATE	8
C	CONCRETE SUMMARY	8
D	BASE AND BITUMINOUS SUMMARY	8
E	MILL BITUMINOUS SURFACE (2")	8
F	STORM SEWER/CULVERT TABULATION	9
G	TURF ESTABLISHMENT AND EROSION CONTROL	9
H	PERMANENT PAVEMENT MARKINGS	64
I	EARTHWORK BALANCE	6
J	CULVERT TABULATION	9
K	TRAFFIC BARRIER	9
	SIGNAL SYSTEM	81
	PRIVATE UTILITY OWNERS	10
	CENTERPOINT	10
	CONNEXUS	10
	CENTURYLINK	10
	COMCAST	10

1	5/21/12	BAV	JEO	CAK	QUANTITIES UPDATED
1	6/6/12	BAV	JEO	CAK	QUANTITIES UPDATED
NO	DATE	BY	CHKD	APPR	REVISION
NAME: p:\116-65\plant\116-65_SEQ.dgn					06/27/2012 8:34:22 AM

I HEREBY CERTIFY THAT THIS PLAN WAS PREPARED BY ME OR UNDER MY DIRECT SUPERVISION AND THAT I AM A DULY LICENSED PROFESSIONAL ENGINEER UNDER THE LAWS OF THE STATE OF MINNESOTA.  
 PRINT NAME: Curt Kobilercsik  
 SIGNATURE: *Curt Kobilercsik*  
 DATE: 6-27-12 LICENSE NO. 24756

DRAWN BY BAV DATE 3-23-12  
 DESIGN BY BAV DATE 3-23-12  
 CHECKED BY JEO DATE 4-10-12



ANOKA COUNTY  
 HIGHWAY DEPT.

S.P. 0208-145 (T.H. 65)  
 S.A.P. 002-716-013  
 S.A.P. 197-020-004

STATEMENT OF  
 ESTIMATED QUANTITIES

SOILS AND CONSTRUCTION NOTES:

1. TOP OF THE GRADING SUBGRADE (GRADING GRADE) IS DEFINED AS THE BOTTOM OF THE CLASS 5 AGGREGATE BASE LAYER.
2. BOTTOM OF SUBBASE GRADE SHALL BE DEFINED AS THE BOTTOM OF THE 1' SUBGRADE TREATMENT.
3. SUITABLE GRADING MATERIAL ON THIS PROJECT SHALL CONSIST OF ALL GRANULAR AND FINER GRAINED SOILS ENCOUNTERED WITH THE EXCEPTION OF TOPSOIL, DEBRIS, PEAT, MUCK, ORGANIC MATERIAL, AND OTHER UNSTABLE MATERIAL.
4. SELECT GRANULAR MATERIAL SHALL MEET THE REQUIREMENTS OF MN/DOT SPEC. 3149.2B2.
5. ALL TOPSOIL STRIPPING WILL BE CONSIDERED TO BE COMMON EXCAVATION.
6. SELECT GRANULAR MATERIAL SHALL BE USED TO BACK FILL THE EMBANKMENT UNDER THE NEW ROADWAY CORE, UP TO THE TOP OF THE GRADING SUBGRADE.
7. REMOVED
8. TOPSOIL SHALL BE DEFINED AS EXISTING SOILS WHICH MEET MN/DOT SPECIFICATION 3877 THAT WOULD BE SUITABLE FOR REUSE.
9. UNSUITABLE SOILS ARE DEFINED AS SOILS WHICH DO NOT MEET OR ARE NOT MANUFACTURED TO MEET ANY OF THE ABOVE DEFINED CATEGORIES, AND ARE THEREFORE NOT REUSABLE AS STRUCTURAL BACKFILL OR EMBANKMENT WITHIN THE ROADWAY CORE.
10. SUITABLE GRADING MATERIAL OBTAINED FROM COMMON EXCAVATION NOT MEETING THE REQUIREMENTS OF MN/DOT SPEC 3149.2B1, SHALL BE USED AS EMBANKMENT MATERIAL ON THE PROJECT AS APPROVED BY THE ENGINEER.
11. UNSUITABLE MATERIALS ARE TOPSOILS, PAVEMENT OR CONCRETE DEBRIS, PEAT, MUCK AND ORGANIC OR OTHER UNSTABLE SOILS.
12. ALL TOPSOIL AND MUCK MATERIAL SHALL BE USED THROUGHOUT THE PROJECT AND AS DIRECTED BY THE ENGINEER.
13. REGULAR EMBANKMENT SHALL BE DEFINED AS ALL GRADING MATERIALS THAT ARE APPROPRIATE FOR REUSE ON THE PROJECT BUT THAT MAY NOT MEET THE REQUIREMENTS OF SUITABLE GRADING MATERIALS. REGULAR EMBANKMENT MAY CONSIST OF GRADING SOILS NOT MEETING GRANULAR SPECIFICATIONS AND THEREFORE NOT SUITABLE FOR REUSE UNDER ROAD CORE. REGULAR EMBANKMENT MAY CONSIST OF TOPSOIL AND ORGANIC SOILS; UNLESS THE ENGINEER DETERMINES THESE SOILS IS NOT REUSABLE, IN WHICH CASE THE CONTRACTOR SHALL REMOVE THEM FROM THE PROJECT LIMITS. REGULAR EMBANKMENT SHALL NOT CONSIST OF DEBRIS.
14. AGGREGATE SHOULDERING MATERIAL FOR THIS PROJECT SHALL BE CLASS 5 GRADATION IN ACCORDANCE WITH MN/DOT 2221 AND 3138.
15. SLOPE DRESSING ON THE PROJECT IS DEFINED AS THE TOPSOIL OR OTHER SOIL PLACED DURING PRIOR CONSTRUCTION TO PROVIDE A MEDIUM FOR ESTABLISHING TURF.
16. IN ALL AREAS OF NEW MAINLINE ROADWAY RECONSTRUCTION (PERMANENT AND TEMPORARY), PROVIDE FOR A MINIMUM 12 INCH COMPACTION SUBCUT UNLESS OTHERWISE NOTED. BACKFILL COMPACTION SUBCUT WITH SELECT GRANULAR MATERIAL. ANY UNCONTAMINATED SUITABLE GRANULAR MATERIAL REMOVED FROM THE EXISTING SUBGRADE AREA MAY BE USED IN OTHER AREAS DESIGNATED FOR THE SAME MATERIAL.
17. UNLESS OTHERWISE SPECIFICALLY ALLOWED OR REQUIRED BY THE CONTRACT, BITUMINOUS AND CONCRETE ITEMS DISTURBED BY CONSTRUCTION SHALL BECOME THE PROPERTY OF THE CONTRACTOR AND SHALL BE RECYCLED TO THE EXTENT ALLOWED IN BASE AND SURFACING ITEMS OR DISPOSED OF OUTSIDE THE RIGHT-OF-WAY IN ACCORDANCE WITH SPEC. 2104.3C3.
18. UNLESS OTHERWISE REQUIRED, IN ALL TREATMENTS, THE CONTRACTOR SHOULD STRIVE TO SUBSTANTIALLY MATCH THE SOILS INPLACE IN THE UPPER 5.0 FEET OF THE ROADWAY.
19. WHERE CONNECTING NEW SURFACING ADJACENT TO ANY INPLACE PAVEMENTS TO BE WIDENED, CUT VERTICALLY TO THE BOTTOM OF THE INPLACE SURFACING OR TO THE BOTTOM OF THE NEW SURFACING DESIGN, WHICHEVER IS DEEPER, THEN AT 1:2 SLOPE TO THE BOTTOM OF THE RECOMMENDED SUBGRADE EXCAVATION.
20. REMOVED
21. WHERE MATCHING INTO INPLACE CROSSROADS, CUT VERTICALLY TO THE BOTTOM OF THE INPLACE SURFACING OR TO THE BOTTOM OF THE NEW SURFACING DESIGN, WHICHEVER IS DEEPER, THEN AT A 1:4 TAPER TO THE BOTTOM OF THE RECOMMENDED SUBGRADE EXCAVATION.
22. USE TACK COAT BETWEEN ALL BITUMINOUS MIXTURES AND PRIOR TO PLACING ANY BITUMINOUS MIXTURES ON THE EXISTING PAVEMENT. THE BITUMINOUS TACK COAT MATERIAL SHALL BE APPLIED AT A UNIFORM RATE OF 0.03 TO 0.05 GALLONS/SQ. YD. BETWEEN BITUMINOUS LAYERS AND 0.07 TO 0.10 GALLONS/SQ. YD. ON CONCRETE OR MILLED BITUMINOUS SURFACES PRIOR TO BEING OVERLAID. THE APPLICATION RATES ARE FOR UNDILUTED EMULSIONS (AS SUPPLIED FROM THE REFINERY) OR MC AND RC LIQUID ASPHALTS. THE ASPHALT EMULSION MAY BE FURTHER DILUTED IN THE FIELD IN ACCORDANCE WITH SPECIFICATION 2357.
23. PROVIDE A SAWCUT WHERE PLACING NEW PAVEMENT ADJACENT TO INPLACE PAVEMENT TO ENSURE A UNIFORM JOINT.
24. STRIP ALL TOPSOIL AND INPLACE SLOPE DRESSING WHERE PRESENT IN AREAS TO BE DISTURBED BY CONSTRUCTION AND REUSE AS SLOPE DRESSING. FOR ESTIMATING PURPOSES, THE DEPTH OF TOPSOIL AVAILABLE IS CONSIDERED TO BE 4 INCHES.
25. EMBANKMENT QUANTITIES SHOWN ON THE EARTHWORK TABULATION REPRESENT ALL EARTHWORK QUANTITIES BELOW THE PROPOSED GRADING GRADE OF ALL PERMANENT ROADWAYS. QUANTITIES REQUIRED ABOVE THE GRADING GRADE OR FOR TEMPORARY CONSTRUCTION ARE PROVIDED IN DETAIL ON THE BITUMINOUS SUMMARY TAB.
26. THE CONSTRUCTION LIMITS AS SHOWN IN THE PLANS REPRESENT THE POINT OF INTERSECTION BETWEEN THE REQUIRED FILL OR CUT SLOPE AND THE EXISTING GROUND LINE AS DEPICTED ON THE CROSS SECTIONS. THE CONSTRUCTION LIMITS DO NOT INCLUDE AREAS REQUIRED FOR SLOPE ROUNDING.
27. DITCH BOTTOMS, TOE OF FILL, CUT RUNOUTS AND THE TOP EDGE OF THE BACKSLOPES SHALL BE ROUNDED REGARDLESS OF THE SECTION USED ON THE CROSS SECTION SHEETS.
28. ANY DEBRIS WHICH MAY BE ENCOUNTERED DURING GRADING SHALL BE DISPOSED OF BY THE CONTRACTOR OFF THE PROJECT RIGHT OF WAY IN A SUITABLE DISPOSAL AREA AS APPROVED BY THE ENGINEER.
29. UNSUITABLE SOILS NOT USED ON THE PROJECT SHALL BECOME THE PROPERTY OF THE CONTRACTOR AND REMOVED FROM THE PROJECT AND DISPOSED OF IN ACCORDANCE WITH MN/DOT SPECIFICATIONS.
30. DISPOSITION OF EXCAVATED MATERIAL SHALL BE IN ACCORDANCE WITH SPECIFICATION 2105.3D.
31. INPLACE BITUMINOUS PAVEMENT RANGES FROM 4" TO 6" THICK. (AVERAGE 5"). FOR INFORMATION ONLY, CONTRACTOR TO VERIFY PAVEMENT DEPTH PRIOR TO PLACING BID.
32. AGGREGATE BASE MATERIAL SHALL BE 100% CRUSHED AND MEET THE REQUIREMENTS OF MN/DOT SPEC. 3138, CLASS 5.

1	6/22/12	BAV	JEO	CAK	TEXT UPDATED
<small>I HEREBY CERTIFY THAT THIS PLAN WAS PREPARED BY ME OR UNDER MY DIRECT SUPERVISION AND THAT I AM A DULY LICENSED PROFESSIONAL ENGINEER UNDER THE LAWS OF THE STATE OF MINNESOTA.</small> PRINT NAME: <u>Curt Kobileroski</u> SIGNATURE: <u><i>Curt Kobileroski</i></u> DATE: <u>6-27-12</u> LICENSE NO. <u>24758</u>					
DRAWN BY <u>DFP</u> DATE <u>10/31/11</u>		DESIGN BY <u>DFP</u> DATE <u>10/31/11</u>		 <b>ANOKA COUNTY HIGHWAY DEPT.</b>	
CHECKED BY <u>JEO</u> DATE <u>4-10-12</u>					
S.P. 0208-145 (T.H. 65) S.A.P. 002-716-013 S.A.P. 197-020-004					
					<b>SOILS AND CONSTRUCTION NOTES</b>
					Sheet <u>5</u> of <u>108</u> Sheets

STATION	EXCAVATION		EMBANKMENT VOLUMES		
	COMMON (CU YD)	SUBGRADE (CU YD)	TOPSOIL (CU YD)	SUITABLE (CU YD)	SEL. GRAN. (CU YD)
103+50.00	16	18	11	17	18
104+00.00	22	20	13	31	20
104+50.00	26	21	15	46	22
105+00.00	25	23	14	42	24
105+17.34	9	9	5	9	9
105+50.00	24	18	5	6	18
105+52.56	2	1			1
106+00.00	38	27	4	13	31
106+50.00	32	35	9	17	39
107+00.00	41	41	4	3	41
107+17.00	13	12	1	1	14
107+50.00	20	24	5	3	28
108+00.00	43	43	5	1	44
108+50.00	69	43	2		43
109+00.00	70	40	2		40
109+50.00	43	40	3		40
109+90.30	37	32	1		32
110+00.00	11	8	1		8
110+50.00	41	37	8	3	40
111+00.00	40	42	4	3	44
111+10.60	16	10			10
111+32.74	35	25	1		25
111+50.00	17	18	2	3	19
112+00.00	36	41	8	17	49
112+50.00	34	39	8	14	49
113+00.00	32	37	7	17	49
113+26.86	17	19	4	13	26
113+50.00	14	16	3	12	23
114+00.00	30	36	7	21	46
114+50.00	28	36	6	17	41
115+00.00	26	36	6	15	40
115+50.00	24	42	6	15	44
116+00.00	21	43	5	9	44
<b>SUBTOTAL (CSAH 116)</b>	<b>952</b>	<b>932</b>	<b>175</b>	<b>348</b>	<b>1021</b>
671+00.00					
671+50.00	19	14	7	6	14
672+00.00	20	18	7	14	19
672+50.00	23	21	7	20	25
673+00.00	24	22	7	25	31
673+50.00	26	22	7	31	37
674+00.00	28	23	6	35	43
674+50.00	30	23	6	35	48
675+00.00	32	25	6	35	50
675+50.00	34	28	7	34	50
676+00.00	35	32	7	28	50
676+50.00	27	26	7	23	38
677+00.00	21	16	7	23	27
677+50.00	21	16	7	23	27
678+00.00	20	15	7	26	27
678+50.00	20	18	7	26	27
679+00.00	21	24	6	15	27
<b>SUBTOTAL NB 65</b>	<b>401</b>	<b>343</b>	<b>108</b>	<b>399</b>	<b>540</b>

STATION	EXCAVATION		EMBANKMENT VOLUMES		
	COMMON (CU YD)	SUBGRADE (CU YD)	TOPSOIL (CU YD)	SUITABLE (CU YD)	SEL. GRAN. (CU YD)
682+68.78					
683+00.00	32	17	1		17
683+50.00	50	27	3		27
684+00.00	53	27	5	1	27
684+50.00	52	27	5	2	27
685+00.00	50	27	5	5	27
685+50.00	46	25	5	5	25
686+00.00	39	20	4	1	20
686+50.00	29	15	2		15
686+77.48	13	7			7
<b>SUBTOTAL SB 65</b>	<b>364</b>	<b>192</b>	<b>30</b>	<b>14</b>	<b>192</b>
<b>PROJECT TOTAL</b>	<b>1717</b>	<b>1467</b>	<b>313</b>	<b>761</b>	<b>1753</b>

EARTHWORK BALANCE			
EXCAVATION (CU YD)			
COMMON (EV) (1)	1,717	SUITABLE	1,027 (EV) / 1.2 = 856 (CV)
SUBGRADE EX (EV) (P) (2)	1,467	EXISTING TOPSOIL	690 (EV) / 1.2 = 575 (CV)
EMBANKMENT (CU YD)			
		SUITABLE	761 (CV)
		TOPSOIL	313 (CV)
		SELECT GRANULAR	1,753 (CV)
TOPSOIL AND SUITABLE MATERIAL (CU YD)			
		TOPSOIL	575 (CV) - 313 (CV) = 262 (CV) (4)
		SUITABLE	856 (CV) - 761 (CV) = 95 (CV) (3)
BORROW (CU YD)			
		SELECT GRANULAR	1,753 (CV) - 1,223 (CV) = 531 (CV) (5)

- (1) TOTAL COMMON EXCAVATION FOR PROJECT (INCLUDING TOPSOIL)
- (2) TOTAL SUBGRADE EXCAVATION FOR PROJECT
- (3) TOTAL SUITABLE GRADING FOR PROJECT
- (4) TOTAL TOPSOIL FOR PROJECT
- (5) TOTAL SELECT GRANULAR BORROW FOR PROJECT
- (6) ALL SUBGRADE EXCAVATION ASSUMED TO MEET REQUIREMENTS FOR SELECT GRANULAR BORROW

NO	DATE	BY	CKD	APPR	REVISION
NAME: p1116-65\plan1116-65_EW_P1.dgn					

I HEREBY CERTIFY THAT THIS PLAN WAS PREPARED BY ME OR UNDER MY DIRECT SUPERVISION AND THAT I AM A DULY LICENSED PROFESSIONAL ENGINEER UNDER THE LAWS OF THE STATE OF MINNESOTA.

PRINT NAME: Curt Koblercaik  
SIGNATURE: *Curt Koblercaik*  
DATE: 6-27-12 LICENSE NO. 24756

DRAWN BY: DFF DATE: 02/23/12  
DESIGN BY: BAV DATE: 02/23/12  
CHECKED BY: JEO DATE: 4-10-12

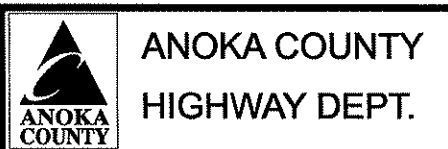

S.P. 0208-145 (T.H. 65)  
S.A.P. 002-716-013  
S.A.P. 197-020-004

STANDARD PLATES	
THESE STANDARD PLATES, AS APPROVED BY THE FHWA, SHALL APPLY	
PLATE NO.	DESCRIPTION
3000L	REINFORCED CONCRETE PIPE
3006G	GASKET JOINT FOR R.C. PIPE
3007D	SHEAR REINFORCEMENT FOR PRECAST DRAINAGE STRUCTURES
3100G	CONCRETE APRON FOR REINFORCED CONCRETE PIPE
3133C	RIPRAP AT RCP OUTLETS
3145F	CONCRETE PIPE TIES
4006L	MANHOLE OR CATCH BASIN
4011E	PRECAST CONCRETE BASE COVER
4018A	MANHOLE OR CATCH BASIN REDUCER CONE SECTION
4020J	MANHOLE OR CATCH BASIN COVER
4026A	CONCRETE ENCASED CONCRETE ADJUSTING RINGS
4101D	RING CASTING FOR MANHOLE OR CATCH BASIN
4108F	ADJUSTING RINGS FOR CATCH BASIN OR MANHOLES
4132F	CATCH BASIN FRAME CASTING (FOR SQUARE GRATE) - CASTING NO. 805
4140D	SPECIAL GRATE CASTINGS FOR CATCH BASIN (CONVEX & CONCAVE) - CASTING NO. 720 & 721
4154B	CATCH BASIN GRATE CASTING - CASTING NO. 816
4180J	MANHOLE OR CATCH BASIN STEP
7035N	CONCRETE WALK AND CURB RETURNS AND ENTRANCES
7038A	DETECTABLE WARNING SURFACE TRUNCATED DOMES
7100H	CONCRETE CURB AND GUTTER
7111J	INSTALLATION OF CATCH BASIN CASTINGS
7113A	CONCRETE APPROACH NOSE DETAIL
8000I	STANDARD BARRICADES

NOTE:  
FOR ADDITIONAL STANDARD PLATES SEE SHEET 81

BASIS FOR ESTIMATED QUANTITIES
BITUMINOUS MIXTURES (ROADWAY AND TRAIL); 115 LB / SY / IN
BITUMINOUS MATERIAL FOR TACK COAT: 0.05 GAL / SY
SEED MIXTURE NO. 240 75 LB / ACRE
COMMERCIAL FERTILIZER TYPE 3 (22-5-10) 350 LB / ACRE

1	5/21/12	BAV	JEO	CAK	STANDARD PLATES/TAB INDEX UPDATED
2	6/22/12	BAV	JEO	CAK	STANDARD PLATES UPDATED
NO	DATE	BY	CKD	APPR	REVISION
NAME: p:\116-65\plant\116-65_TAB.dgn					06/27/2012 8:34:27 AM

I HEREBY CERTIFY THAT THIS PLAN WAS PREPARED BY ME OR UNDER MY DIRECT SUPERVISION AND THAT I AM A DULY LICENSED PROFESSIONAL ENGINEER UNDER THE LAWS OF THE STATE OF MINNESOTA.  
 PRINT NAME: Curt Koblercek  
 SIGNATURE: *Curt Koblercek*  
 DATE: 6-27-12 LICENSE NO. 24758

DRAWN BY BAV DATE 3-23-12  
 DESIGN BY BAV DATE 3-23-12  
 CHECKED BY JEO DATE 4-10-12



**ANOKA COUNTY**  
**HIGHWAY DEPT.**

S.P. 0208-145 (T.H. 65)  
 S.A.P. 002-716-013  
 S.A.P. 197-020-004

**STANDARD PLATES &  
BASIS OF QUANTITIES**

CLEAR AND GRUB						A
ALIGNMENT	STATION	OFFSET		CLEARING & GRUBBING		NOTES
				(TREE)	(TREE)	
CSAH 116	108+17.76	42	LT	1	1	
CSAH 116	109+69.88	41	LT	1	1	
CSAH 116	111+81.77	40	LT	2	2	
PROJECT TOTAL				4	4	

**CLEARING & GRUBBING GENERAL NOTES:**  
 TREES WITHIN THE CONSTRUCTION LIMITS AND THE COUNTY RIGHT OF WAY WILL BE DESIGNATED FOR REMOVAL BY THE ENGINEER. REMOVAL OF MISCELLANEOUS SHRUBS AND LANDSCAPING SHALL BE CONSIDERED INCIDENTAL.

CONCRETE CURB AND GUTTER, CONCRETE MEDIAN										C
BEGIN STATION	END STATION	LOCATION	DESCRIPTION	CONCRETE CURB & GUTTER DESIGN B-424	CONCRETE CURB & GUTTER DESIGN B-424 (MOD)	PEDESTRIAN CURB RAMP (1)	TRUNCATED DOME	6" CONCRETE DRIVEWAY	6" CONCRETE WALK (MEDIAN)	CONCRETE FLUME
				LIN FT	LIN FT	SQ FT	SQ FT	SQ YD	SQ FT	EACH
<b>C.S.A.H. 116</b>										
102+36.14	105+09.42	LT LWB	SHOULDER	273						1
104+85.62		LT LWB								
105+09.42	105+38.82	LT LWB	LT LINCOLN ST	49						
105+66.30	105+96.69	LT LWB	RT LINCOLN ST	48						
105+96.69	110+67.67	LT LWB	SHOULDER	472						
108+43.95	108+59.70	LT LWB	DRIVEWAY					40		
110+67.67	110+97.60	LT LWB	LT JOHNSON ST	51						
110+89.47		LT LWB								1
111+23.60	111+53.59	LT LWB	RT JOHNSON ST	47						
111+53.59	115+30.00	LT LWB	SHOULDER	377						
111+93.39	112+07.00	RT LWB	MEDIAN		14				86	
113+19.86	113+33.86	RT LWB	MEDIAN		28				56	
SUBTOTAL CSAH 116				1317	42			40	142	2
<b>T.H. 65</b>										
115+30.00	115+96.61	LT LWB	TURN LANE	112		54	12			
115+86.75	116+20.56	LT LWB	NW ISLAND	163		105	24		502	
679+07.00	607+18.00	LT LNB	S. MEDIAN				24		494	
678+84.50	678+96.74	LT LSB	SW PED RAMP			98	19			
679+08.97	679+26.70	RT LNB	SE PED RAMPS	52		145	36		112	
680+32.18	680+44.85	RT LNB	NE PED RAMP			80	8			
SUBTOTAL TH 65				327		482	123		1108	
TOTAL				1644	42	482	123	40	1250	2

NOTE:  
 (1) PAID FOR AS 6" CONCRETE WALK

MILL BITUMINOUS SURFACE (2")					E
STATION	STATION	LOCATION	DESCRIPTION	MILL BIT SURFACE	
				SQ YD	
670+55	679+25	N.B. T.H. 65	SOUTH OF CSAH 116	4638	
680+12	686+76	N.B. T.H. 65	NORTH OF CSAH 116	2895	
670+57	679+21	S.B. T.H. 65	SOUTH OF CSAH 116	4309	
679+94	686+78	S.B. T.H. 65	NORTH OF CSAH 116	3159	
TOTAL				15001	

REMOVALS, SAWING & RELOCATE											B
STATION TO STATION	OFFSET	SAWING (SPEC. 2104)	REMOVE (SPEC. 2104)						RELOCATE (SPEC. 2540)		
			BIT. PAVEMENT (FULL DEPTH) (LIN FT)	BITUMINOUS PAVEMENT (SQ FT)	CONC. CURB & GUTTER (LIN FT)	CONCRETE MEDIAN (SQ FT)	CONCRETE SLAB (SQ YD)	PIPE SEWERS (LIN FT)	PIPE CULVERT (LIN FT)	REMOVE MH OR CB (EACH)	MAILBOX SUPPORT (EACH)
<b>CSAH 116</b>											
102+97 - 115+41	LT	1463	20582						195		
105+18 - 107+14	LT									1	
105+99	LT										1
108+88 - 107+13	LT	9	365					25			1
108+36 - 108+68	LT		279								1
109+79 - 110+03	LT	16	489						24		1
111+34 - 111+45	LT								13		
112+00	RT			14					45		
113+27	RT			28		56			51		
SUBTOTAL		1488	21715	42	56	25	304	24	1	3	
<b>TH 65</b>											
670+55 - 676+45	LT	920	2790								
682+69 - 686+78	RT	453	2323								
679+95	LT		4693	149	580						
679+09	RT			52	257						
680+32	RT				80						
SUBTOTAL		1373	9806	201	917						
PROJECT TOTAL		2861	31521	243	973	25	304	24	1	3	

REMOVAL NOTES:  
 ASSUMED PAVEMENT DEPTH OF 6" FOR INFORMATION ONLY. CONTRACTOR TO VERIFY.

BASE AND BITUMINOUS SUMMARY											D
BEGIN STATION	END STATION	DESCRIPTION	AREA	AGGREGATE BASE CLASS 5	2360 TYPE SP 12.5 WEAR (SPWEB340F)	2360 TYPE SP 12.5 NON-WEAR (SPNWB330B)	2357 BIT. TACK COAT	OVERLAY 2360 TYPE SP 12.5 WEAR (SPWEB440F)	AGGREGATE SHOULDERING (CV), CLASS 5	DRIVEWAYS	
										4" AGGREGATE BASE CLASS 5	TYPE SP 12.5 WEAR (SPWEB230B)
			SQ YD	CU YD	TON	TON	GAL	TON	CU YD	CU YD	TON
<b>CSAH 116</b>											
102+37	105+09	MAINLINE	257	73	59	33	26				
105+09	105+97	LINCOLN ST.	149	34	34	19	15				
105+97	108+71	LINCOLN ST. TURN LANE	315	79	72	41	32				
105+09	110+68	MAINLINE	791	151	182	102	79				
106+89	107+12	DRIVEWAY	18							2	2
108+40	108+64	DRIVEWAY	9							3	1
110+68	111+54	JOHNSON ST.	131	31	30	17	13				
110+68	116+29	MAINLINE	963	170	221	125	96				
111+54	114+29	JOHNSON RT TURN LANE	315	79	72	41	32				
115+30	116+29	RT/ISLAND	231	63	53	30	23				
SUBTOTAL ANOKA COUNTY (TURN LANES)				159	144	82	64				
SUBTOTAL CSAH 116 (MNDOT)				523	579	326	252			5	3
<b>TH 65</b>											
670+55	679+25	LEFT TURN LANES	1460	243	336	189	146		16		
670+55	686+76	NB T.H. 65 MAIN	7534					866			
670+57	686+78	SB T.H. 65 MAIN	7468					859			
682+69	686+78	LEFT TURN LANE	456	76	105	59	46		8		
SUBTOTAL TH 65 (MNDOT)				319	441	248	192	1725	24		
SUBTOTAL (MNDOT)				842	1020	574	444	1725	24	5	3
PROJECT TOTAL				1001	1164	656	508	1725	24	5	3

1	5/21/12	BAV	JEO	CAK	TABS UPDATED
2	6/22/12	BAV	JEO	CAK	TABS UPDATED
NO	DATE	BY	CHKD	APPR	REVISION
NAME: p:\116-65\plan\116-65_TAB.dgn					06/26/2012 11:41:04 AM

I HEREBY CERTIFY THAT THIS PLAN WAS PREPARED BY ME OR UNDER MY DIRECT SUPERVISION AND THAT I AM A DULY LICENSED PROFESSIONAL ENGINEER UNDER THE LAWS OF THE STATE OF MINNESOTA.  
 PRINT NAME: Curt Kobilarski  
 SIGNATURE: *[Signature]*  
 DATE: 6-27-12 LICENSE NO. 24758

DRAWN BY: BAV DATE: 3-23-12  
 DESIGN BY: BAV DATE: 3-23-12  
 CHECKED BY: JEO DATE: 4-10-12



S.P. 0208-145 (T.H. 65)  
 S.A.P. 002-716-013  
 S.A.P. 197-020-004



### STORM SEWER TABULATION

F

STRUCTURE NO.	CENTER OF CASTING LOCATION		DRAINAGE STRUCTURES					TOP OF CASTING ELEV.	OUTLET ELEV.	DOWN-STREAM INLET ELEV.	SLOPE %	15" RCP CL V LIN FT	SOD TYPE SALT RESISTANT SQ YD	CONNECT TO EX. STORM SEWER EACH	NOTES					
	FLOWS FROM	FLOWS TO	ALIGN.	STATION (2)	OFFSET (2)	TYPE	DESIGN									PAY HEIGHT			CASTING ASSEMBLY TYPE	STEPS REQ'D (3)
																H LIN FT	G LIN FT	48-4020 LIN FT		
100	104	WB	107+17.00	32.40' LT	CB	48-4020			4.2	B-9		899.58	895.25	894.67	0.50	117				
101	100	WB	107+20.15	41.21' LT	CB	H		3.1		M-8		898.61	895.36	895.32	0.50	9				
102	EXIST	WB	106+01.71	38.08' LT	CB	48-4020			4.9	B-9	YES	900.45	895.44		0.50			1		
103	104	WB	105+99.10	44.20' LT	CB	H		3.1		M-8		898.64	895.39	895.32	0.50	14				
104	102	WB	107+16.99	30.06' LT	CB	48-4020			5.6	B-9	YES	900.35	894.67	894.26	0.50	82				
105	100	WB	107+91.14	33.89' LT	CB	H		3.1		B-9		899.12	895.87	895.50	0.50	74				
106	EXIST	WB	111+33.62	50.59' LT	MH	48-4020			2.9	M-8		898.00	894.95					1		
107	108	WB	112+00.36	12.21' RT	CB	H		3.1		R-3448-C		899.45	896.20	895.96	0.50	48		(1)		
108	112	WB	112+00.10	46.95' LT	CB	G			2.7	B-9		898.61	895.82	895.59	0.50	47				
109	110	WB	113+26.86	19.52' RT	CB	H		3.1		R-3448-C		900.33	897.08	896.80	0.50	56		(1)		
110	108	WB	113+26.91	36.00' LT	CB	G			3.2	B-9		899.76	896.45	895.82	0.50	127				
111	106	WB	111+50.00	48.76' LT	CB	G			2.4	M-8		898.00	895.52	895.46	0.50	13		9		
112	111	WB	111+53.60	36.00' LT	CB	48-4020			2.5	B-9		898.25	895.59	895.53	0.50	13				
<b>TOTALS</b>							15.5	8.3	15.9	13						483	36.0	2		

NOTES:

- CLASS C BEDDING FOR RC PIPE UNLESS OTHERWISE SPECIFIED.
- LENGTH GIVEN TO CENTER OF STRUCTURE OR END OF BARREL (DOES NOT INCLUDE APRON LENGTH).
- TIE LAST THREE JOINTS AT APRON END. FURNISHING AND INSTALLING PIPE TIES SHALL BE CONSIDERED INCIDENTAL. SEE MN/DOT STANDARD PLATE 3145.
- (1) R-3448-C NEENAH CASTING ASSEMBLIES OR EAST JORDAN IRON WORKS PRODUCT NO. 00500050C01
- (2) STATION AND OFFSET FOR EACH STRUCTURE ARE GIVEN AT CENTER OF GRATE. INVERT ELEVATIONS ARE GIVEN AT CENTER OF STRUCTURE. STATION, OFFSET, AND ELEVATIONS ARE GIVEN AT END OF APRON FOR STRUCTURES.
- (3) IF STEPS REQUIRED, STRUCTURE TO INCLUDE MANHOLE STEPS 16" ON CENTER. SEE MN/DOT STANDARD PLATE 4180.

### TRAFFIC BARRIER

K

STAGE	STATION TO STATION	RELOCATE PORTABLE PRECAST CONC LIN FT	PORTABLE PRECAST CONCRETE BARRIER LIN FT	IMPACT ATTENUATOR AMBY	RELOCATE IMPACT ATTENUATOR AMBY	NOTES
STAGE 1	670+50 - 679+00		850	2		
STAGE 1	682+47 - 686+68		421	2		
STAGE 2	102+97 - 115+13	881		6	4	
<b>TOTAL</b>		881	1271	10	4	

### CASTING ASSEMBLIES SUMMARY

ASSEMBLY	RING OR FRAME	COVER OR GRATE	CURB BOX	STANDARD PLATE	QUANTITY	REMARKS
M-8	700-7	721		4101 4140	4	Catch Basin
B-9	805	816		4132, 4154	7	Catch Basin
R-3448-C					2	Catch Basin

### CULVERT TABULATION

J

STATION FROM	STATION TO	OFFSET		ALIGNMENT	INVERT UPSTREAM	INVERT DOWNSTREAM	FURNISH AND INSTALL		SALVAGE CONCRETE APRON EACH	INSTALL CONCRETE APRON EACH			
		15" RCP PIPE LIN FT	RIPRAP CL II (4) CU YD										
		FROM	TO										
T.H. 65	679+02	679+02	47	LT	38	LT	LNB	898.82	898.78	9	2.9	1	1
<b>TOTAL</b>							9	2.9	1	1			

NOTES:

- (4) GRANULAR FILTER BLANKET OR GEOTEXTILE FILTER MATERIAL REQUIRED SHALL BE INCIDENTAL. SEE MN/DOT STANDARD PLATE 3133.

### TURF ESTABLISHMENT AND EROSION CONTROL

G

LOCATION	SILT FENCE	STORM DRAIN INLET PROTECTION	SOD TYPE SALT RESISTANT	PERMANENT EROSION CONTROL					TEMPORARY EROSION		
				SEEDING	SEED MIXTURE 240 POUND	EROSION CONTROL BLANKET CAT. 0 SQ YD	FILTER LOG TYPE ROCK LOG LIN FT	FERTILIZER TYPE 3 POUND	RAPID STABILIZATION METHOD 3 M GAL		
<b>C.S.A.H. 116</b>					ACRE	POUND	SQ YD	LIN FT	POUND	M GAL	
102+31		105+39	318	1	0.13	9.8	486	48	46	0.8	
105+66		106+93		2	254	0.05	3.8		18	0.3	
107+08		108+44		3	206	0.03	2.3		11	0.2	
108+60		109+82			85	0.02	1.5	32	7	0.1	
109+98		110+98			95	0.02	1.5		7	0.1	
111+24		115+97	522	7	0.14	10.5	166	32	49	0.8	
<b>T.H. 65</b>											
670+55		679+25	892	1	0.27	20.3	1170		95	1.6	
682+69		686+78	455		0.10	7.5	425		35	0.6	
<b>PROJECT TOTAL</b>			2187	14	640	0.76	57.2	2247	112	268	4.6

1	5/21/12	BAV	JEO	CAK	TABS UPDATED
2	6/22/12	BAV	JEO	CAK	TABS UPDATED
NO	DATE	BY	CKD	APPR	REVISION
NAME: p:\116-65\plan\116-65_TAB.dgn					

I HEREBY CERTIFY THAT THIS PLAN WAS PREPARED BY ME OR UNDER MY DIRECT SUPERVISION AND THAT I AM A DULY LICENSED PROFESSIONAL ENGINEER UNDER THE LAWS OF THE STATE OF MINNESOTA.  
 PRINT NAME: Curt Kobilarcik  
 SIGNATURE: *Curt Kobilarcik*  
 DATE: 6-27-12 LICENSE NO. 24768

DRAWN BY: BAV DATE: 3-23-12  
 DESIGN BY: BAV DATE: 3-23-12  
 CHECKED BY: JEO DATE: 4-10-12



**ANOKA COUNTY**  
**HIGHWAY DEPT.**

S.P. 0208-145 (T.H. 65)  
 S.A.P. 002-716-013  
 S.A.P. 197-020-004

TABULATIONS

PRIVATE UTILITY OWNERS	
CITY OF HAM LAKE 13635 JOHNSON ST NE HAM LAKE, MN 55304	CENTERPOINT ENERGY 700 WEST LINDEN AVE P.O. BOX 1165 MINNAPOLIS, MN 55440-1165
MN/DOT 6000 MINNEHAHA AVE FORT SNELLING 740 ST PAUL, MN 55111	CENTURYLINK CORPORATION 425 MONROE ST ANOKA, MN 55303
CONNEXUS ENERGY 14601 RAMSEY BLVD RAMSEY, MN 55303	COMCAST CABLE 2611 FAIRVIEW AVE ROSEVILLE, MN 55113

\*SEE SHEETS 76 & 77 FOR MN/DOT TRAFFIC SIGNAL UTILITY INFORMATION

CENTERPOINT ENERGY - GAS				
STATION		LOCATION	SIZE & ITEM	NOTES
BEGIN	END			
CSAH 116		OFFSET FROM LWB		
105+22	105+33	65 RT TO 72 LT	2" PE CL-6	LEAVE AS IS
106+25	106+29	67 RT TO 90 LT	SERVICE	LEAVE AS IS
107+76	107+80	70 RT TO 83 LT	SERVICE	LEAVE AS IS
109+39	109+41	70 RT TO 82 LT	SERVICE	LEAVE AS IS
110+91		77 LT TO LT	2" PE CL-6	LEAVE AS IS
114+94	115+37	41 LT TO 39 LT	4" ST CL-6	LEAVE AS IS
114+97	115+51	44 LT TO 45 LT	6" ST CL-E	LEAVE AS IS
115+37	115+46	39 LT TO 65 RT	2" TR CL-6	LEAVE AS IS
115+47		45 LT TO LT	4" PE CL-6	LEAVE AS IS
115+47	117+63	73 LT TO 79 LT	4" PE CL-6	LEAVE AS IS
115+51		45 LT TO LT	6" ST CL-E	LEAVE AS IS
115+52	115+85	67 LT TO 55 LT	6" ST CL-E	LEAVE AS IS
115+85	115+89	55 LT TO RT	6" ST CL-E	LEAVE AS IS

CENTURYLINK - TELEPHONE				
STATION		LOCATION	ITEM	REMARKS
BEGIN	END			
CSAH 116		OFFSET FROM LWB		
102+00	105+87	30 LT TO 34 LT	BURIED	LEAVE AS IS
105+27		40 LT TO LT	BURIED	LEAVE AS IS
105+77		34 LT TO LT	BURIED	LEAVE AS IS
105+81		46 LT	SPLICE BOX	LEAVE AS IS
106+50	108+99	26 LT TO 27 LT	BURIED	RELOCATE
109+10		43 LT	SPLICE BOX	LEAVE AS IS
109+22	111+40	22 LT TO 24 LT	BURIED	RELOCATE
110+87		43 LT TO LT	BURIED	LEAVE AS IS
111+35		62 LT TO LT	BURIED	LEAVE AS IS
111+48	115+36	39 LT TO 41 LT	BURIED	RELOCATE
111+83		39 LT	SPLICE BOX	RELOCATE
111+88	115+42	34 LT TO 34 LT	BURIED	RELOCATE
115+18	115+18	33 LT TO 52 RT	BURIED	RELOCATE
115+42	115+48	34 LT TO 60 RT	UG	RELOCATE

GENERAL UTILITY NOTES
1. IT SHALL BE THE CONTRACTOR'S RESPONSIBILITY TO UTILIZE THE GOPHER STATE ONE CALL EXCAVATION NOTICE SYSTEM REQUIRED BY MINNESOTA STATUTE, CHAPTER 216D FOR ALL UNDERGROUND UTILITY LOCATIONS.
2. THE SUBSURFACE UTILITY INFORMATION IN THIS PLAN IS UTILITY QUALITY LEVEL D. THIS UTILITY QUALITY LEVEL WAS DETERMINED ACCORDING TO THE GUIDELINES OF CIASCE 38-02, ENTITLED "STANDARD GUIDELINES FOR THE COLLECTION AND DEPICTION OF EXISTING SUBSURFACE UTILITY DATA".
3. CONTRACTOR SHALL PROTECT ALL EXISTING UTILITIES
4. ALL PRIVATE IRRIGATION SYSTEMS DISTURBED BY CONSTRUCTION SHALL BE REPLACED AND REINSTALLED AS DIRECTED BY THE CITY (THE CONTRACTOR SHALL TAKE CARE TO PROTECT OR SALVAGE IRRIGATION SYSTEM COMPONENTS WITHIN THE CONSTRUCTION LIMITS)
5. ALL ADJUSTS AND RELOCATES DONE BY OTHERS.

CONNEXUS ENERGY				
STATION		OFFSET	SIZE & ITEM	REMARKS
BEGIN	END			
111+42		40' LT	POWER POLE	RELOCATE
111+93		41' LT	POWER POLE	RELOCATE
112+48		41' LT	POWER POLE	RELOCATE
114+19	114+24	42' LT	ELEC CABINET	RELOCATE
114+28		41' LT	POWER POLE	RELOCATE
115+46		42' LT	POWER POLE	RELOCATE

COMCAST - UNDERGROUND				
STATION		LOCATION	INPLACE ITEM	NOTES
BEGIN	END			
CSAH 116		OFFSET FROM LEB		
105+69	105+80	70 LT TO 60 RT	FIBER	LEAVE AS IS
111+44		69 RT TO 39 LT	FIBER	LEAVE AS IS
115+45		72 LT	SPLICE BOX	LEAVE AS IS
115+47	117+72	71 LT TO 57 LT	FIBER	LEAVE AS IS
115+47		44 LT TO LT	FIBER	LEAVE AS IS

1	5/21/12	BAV	JEO	CAK	TABS UPDATED
2	6/22/12	BAV	JEO	CAK	TABS UPDATED
NO	DATE	BY	CKD	APPR	REVISION
NAME: p:\118-65\plan\118-65_TAB.dgn					
06/26/2012 11:41:08 AM					

I HEREBY CERTIFY THAT THIS PLAN WAS PREPARED BY ME OR UNDER MY DIRECT SUPERVISION AND THAT I AM A DULY LICENSED PROFESSIONAL ENGINEER UNDER THE LAWS OF THE STATE OF MINNESOTA.

PRINT NAME: Curt Kobilarcik

SIGNATURE: *Curt Kobilarcik*

DATE: 6-27-12 LICENSE NO. 24756

DRAWN BY BAV DATE 3-23-12

DESIGN BY BAV DATE 3-23-12

CHECKED BY JEO DATE 4-10-12



**ANOKA COUNTY**  
**HIGHWAY DEPT.**

S.P. 0208-145 (T.H. 65)  
S.A.P. 002-716-013  
S.A.P. 197-020-004

C.S.A.H. 116

STA. 102+96.29 - STA. 108+90.00

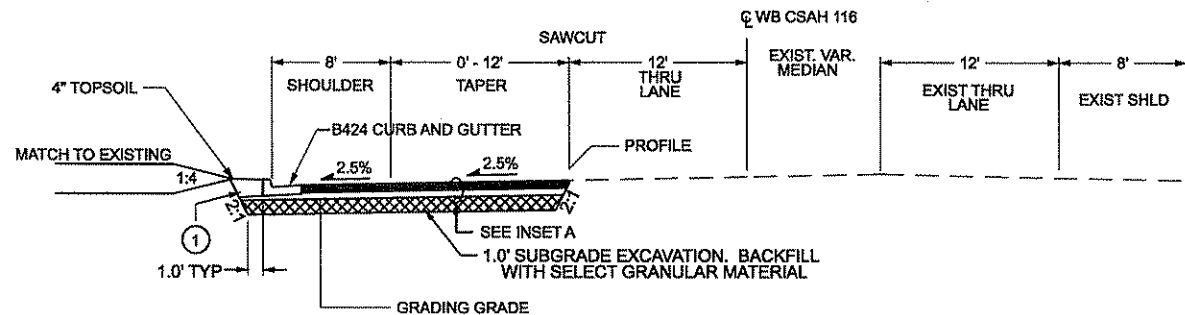

C.S.A.H. 116

STA. 110+61.00 - STA. 114+29.00

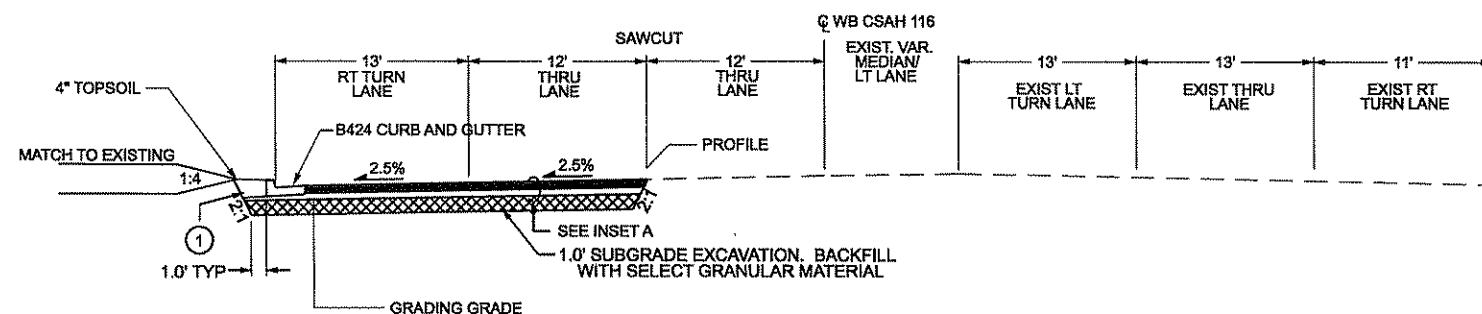

C.S.A.H. 116

STA. 108+90.00 - STA. 110+61.00  
STA. 114+29.00 - STA. 116+29.00

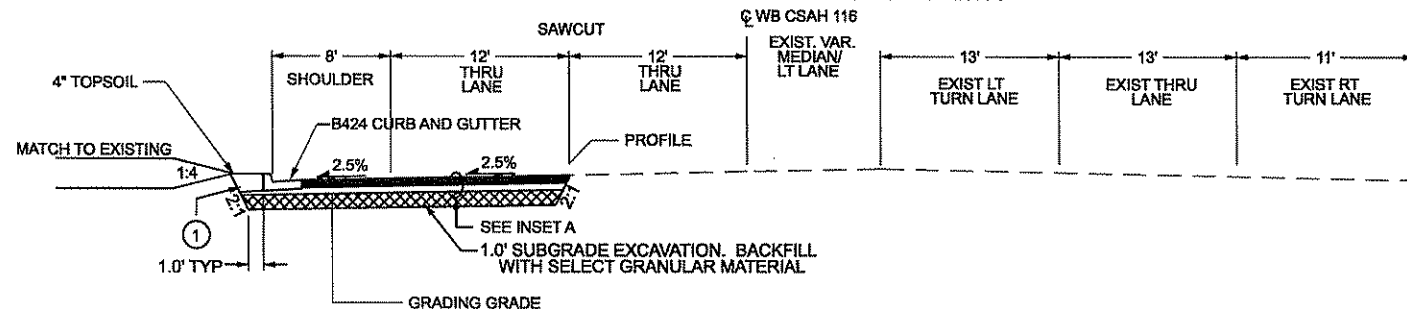

C.S.A.H. 116

STA. 112+00.36 - STA. 113+26.86 (CROSS PIPE REPLACEMENTS)

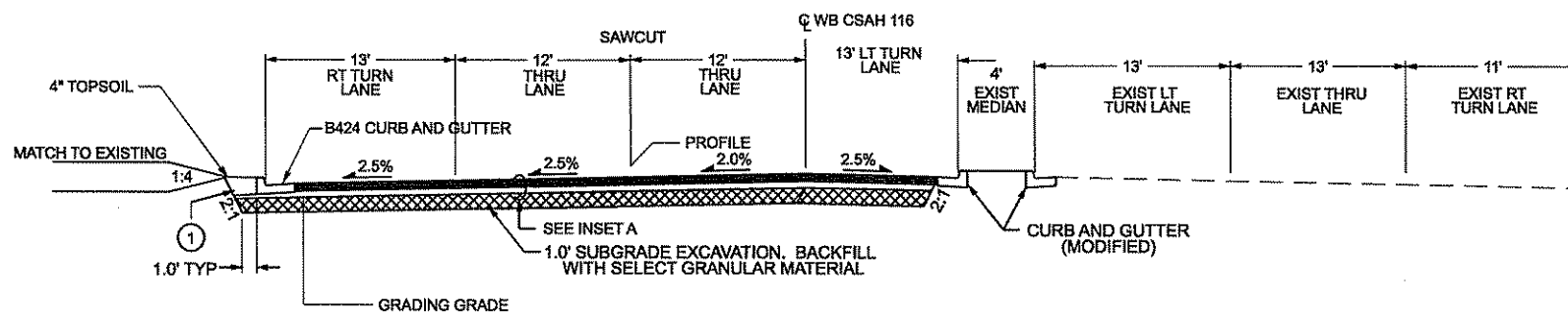

INSET "A" PAVEMENT DESIGN

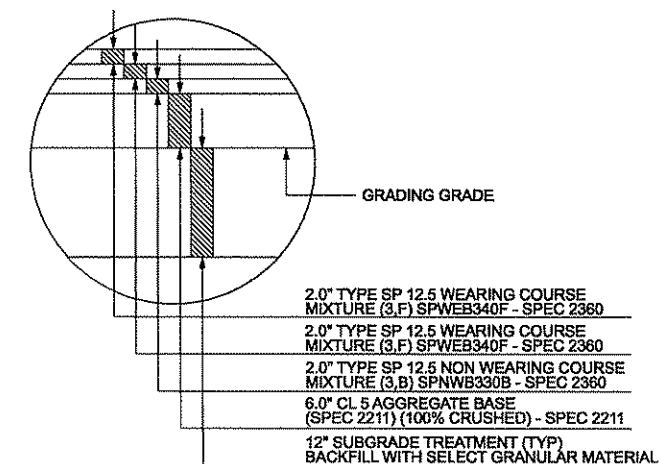

SPECIFIC NOTES:

- ① SUITABLE GRADING MATERIAL
- ② AGGREGATE SHOULDERING, CLASS 5 MNDOT SPEC. 2221

GENERAL NOTES:

- SEE CONSTRUCTION PLANS FOR TAPER LOCATIONS.
- UNLESS OTHERWISE SPECIFIED, THE GRADING GRADE CROSS SLOPES SHALL BE THE SAME AS THE FINISHED SURFACE OF THE MAINLINE.
- UNLESS OTHERWISE SPECIFIED, CLASS 5 AGGREGATE WILL EXTEND 1' BEYOND BACK OF CURB.
- THE MIX DESIGN FOR THE MILL & OVERLAY ON TH 65 IS THE SAME AS THE WEARING COURSE MIX DESIGN FOR INSET "B"
- THE MIX DESIGN FOR THE MILL & OVERLAY ON CSAH 116 IS THE SAME AS THE WEARING COURSE MIX DESIGN FOR INSET "A"

1	5/21/12	BAV	JEO	CAK	TYPICAL SECTIONS UPDATED
2	6/22/12	BAV	JEO	CAK	TEXT UPDATED
NO	DATE	BY	CKD	APPR	REVISION
NAME: p:\116-65\plan\116-65_TS_P1.dgn					06/27/2012 8:34:38 AM

I HEREBY CERTIFY THAT THIS PLAN WAS PREPARED BY ME OR UNDER MY DIRECT SUPERVISION AND THAT I AM A DULY LICENSED PROFESSIONAL ENGINEER UNDER THE LAWS OF THE STATE OF MINNESOTA.  
 PRINT NAME: Curt Kobilarcik  
 SIGNATURE: *Curt Kobilarcik*  
 DATE: 6-27-12 LICENSE NO. 24756

DRAWN BY DFF DATE 08-15-11  
 DESIGN BY DFF DATE 08-15-11  
 CHECKED BY JEO DATE 4-10-12



ANOKA COUNTY  
HIGHWAY DEPT.

S.P. 0208-145 (T.H. 65)  
 S.A.P. 002-716-013  
 S.A.P. 197-020-004

TYPICAL SECTIONS

T.H. 65 NB

STA. 670+55 - STA. 676+45

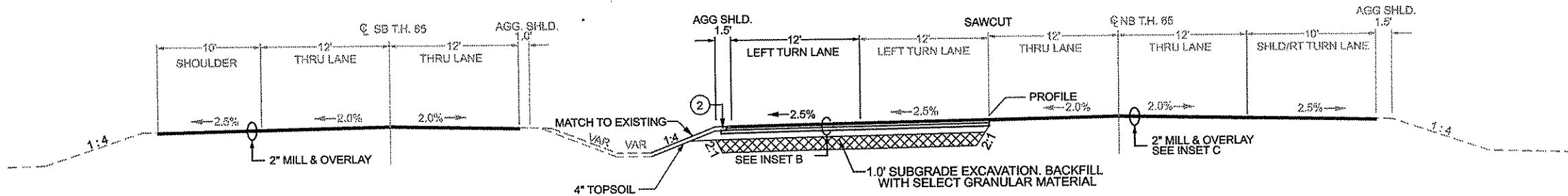

INSET "B" PAVEMENT DESIGN

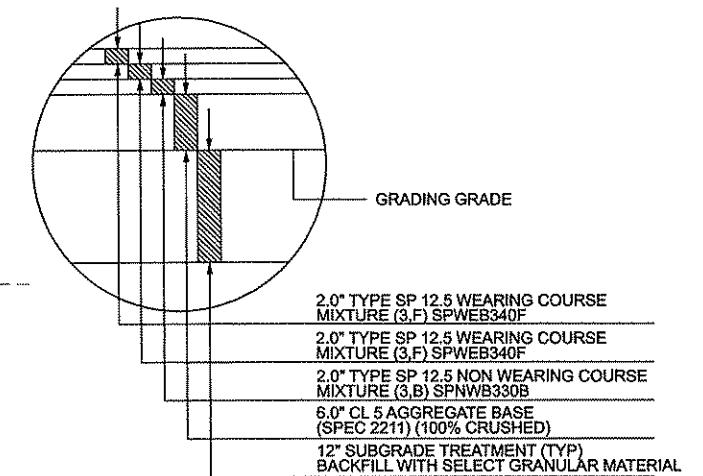

T.H. 65 NB

STA. 676+45 - STA. 679+25

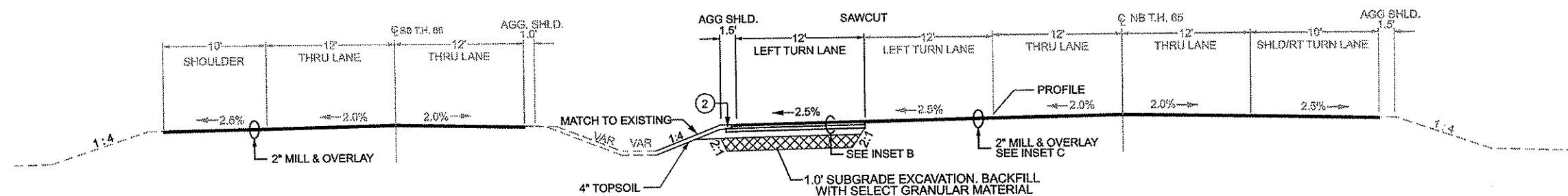

INSET "C" PAVEMENT DESIGN

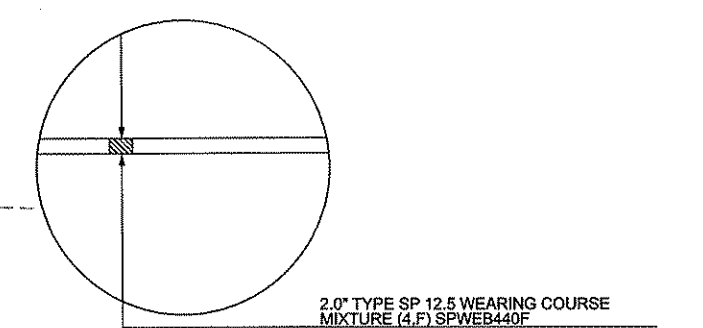

T.H. 65 SB

STA. 680+11 - STA. 686+78

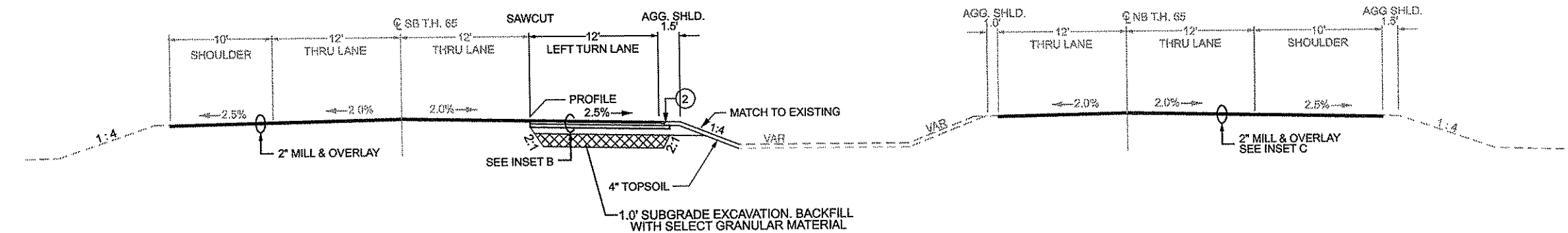

SPECIFIC NOTES:

- ① SUITABLE GRADING MATERIAL
- ② AGGREGATE SHOULDERING, CLASS 5 MNDOT SPEC. 2221

GENERAL NOTES:

- SEE CONSTRUCTION PLANS FOR TAPER LOCATIONS.
- UNLESS OTHERWISE SPECIFIED, THE GRADING GRADE CROSS SLOPES SHALL BE THE SAME AS THE FINISHED SURFACE OF THE MAINLINE.
- THE MIX DESIGN FOR THE MILL & OVERLAY ON TH 65 IS THE SAME AS THE WEARING COURSE MIX DESIGN FOR INSET "B"
- THE MIX DESIGN FOR THE MILL & OVERLAY ON CSAH 116 IS THE SAME AS THE WEARING COURSE MIX DESIGN FOR INSET "A"

1	5/21/12	BAV	JEO	CAK	TYPICAL SECTIONS UPDATED
NO	DATE	BY	CKD	APPR	REVISION
NAME: p:\116-65\plan\116-65_TS_P2.dgn					05/23/2012 2:05:50 PM

I HEREBY CERTIFY THAT THIS PLAN WAS PREPARED BY ME OR UNDER MY DIRECT SUPERVISION AND THAT I AM A DULY LICENSED PROFESSIONAL ENGINEER UNDER THE LAWS OF THE STATE OF MINNESOTA.

PRINT NAME: Curt Kobilarcik

SIGNATURE: Curt Kobilarcik

DATE: 5-23-12 LICENSE NO. 24756

DRAWN BY BAV DATE 3-23-12

DESIGN BY BAV DATE 3-23-12

CHECKED BY JEO DATE 4-10-12

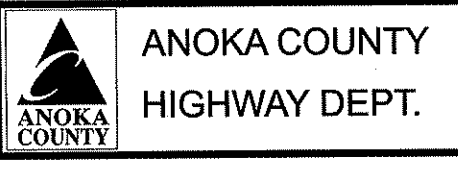

S.P. 0208-145 (T.H. 65)  
 S.A.P. 002-716-013  
 S.A.P. 197-020-004

TYPICAL SECTIONS  
 TH 65

Sheet 12 of 108 Sheets

PLOTTED/REVISED:  
 \$\$\$@DATE\$\$\$

DISTRICT #: \$\$\$DISTRICT\$\$\$  
 USER NAME: \$\$\$USER\$\$\$  
 PATH & FILENAME: \$\$\$PATH\$\$\$

FILE NAME:  
 \$\$\$FILENAME\$\$\$

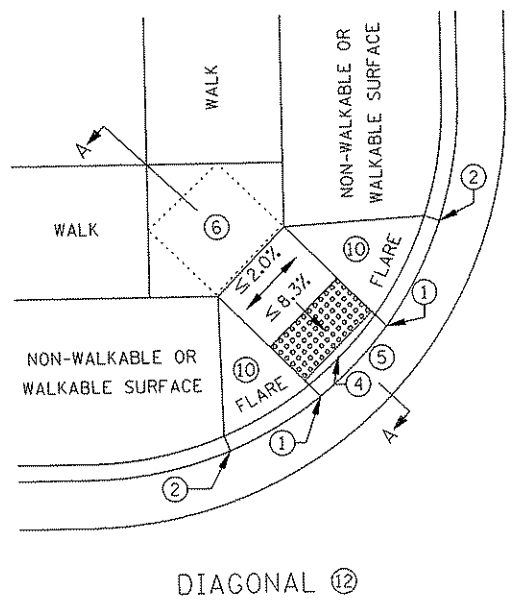
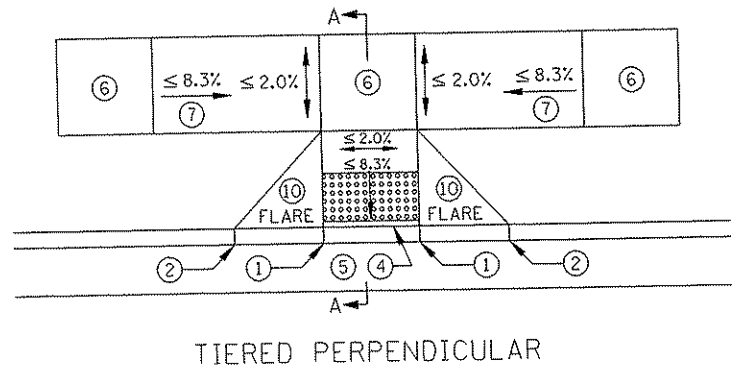
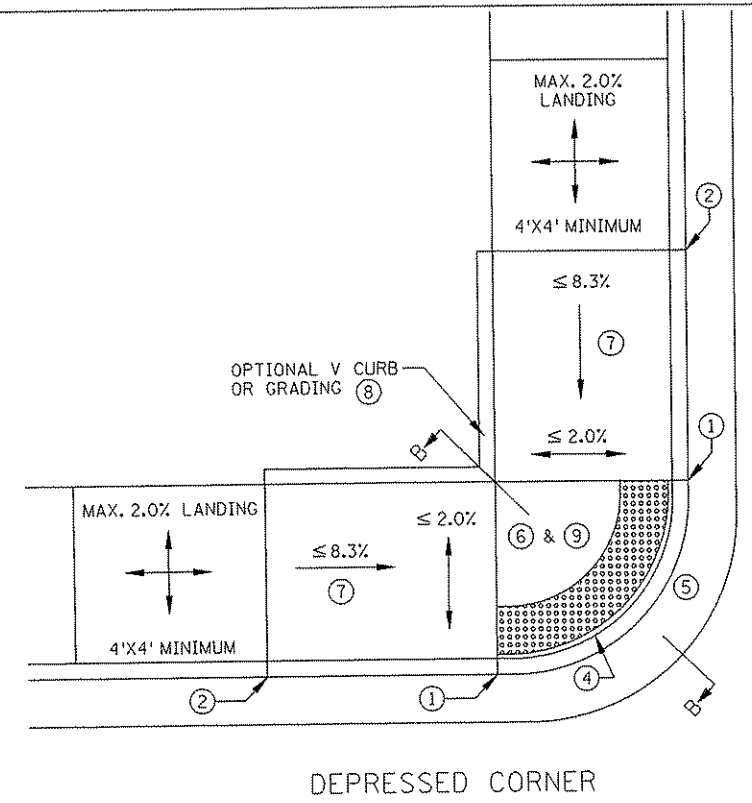
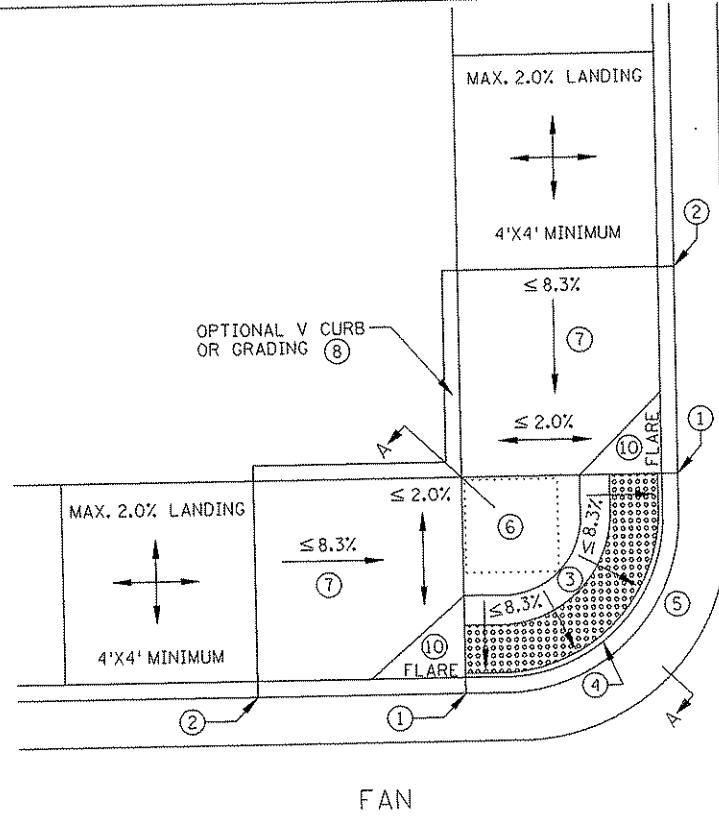
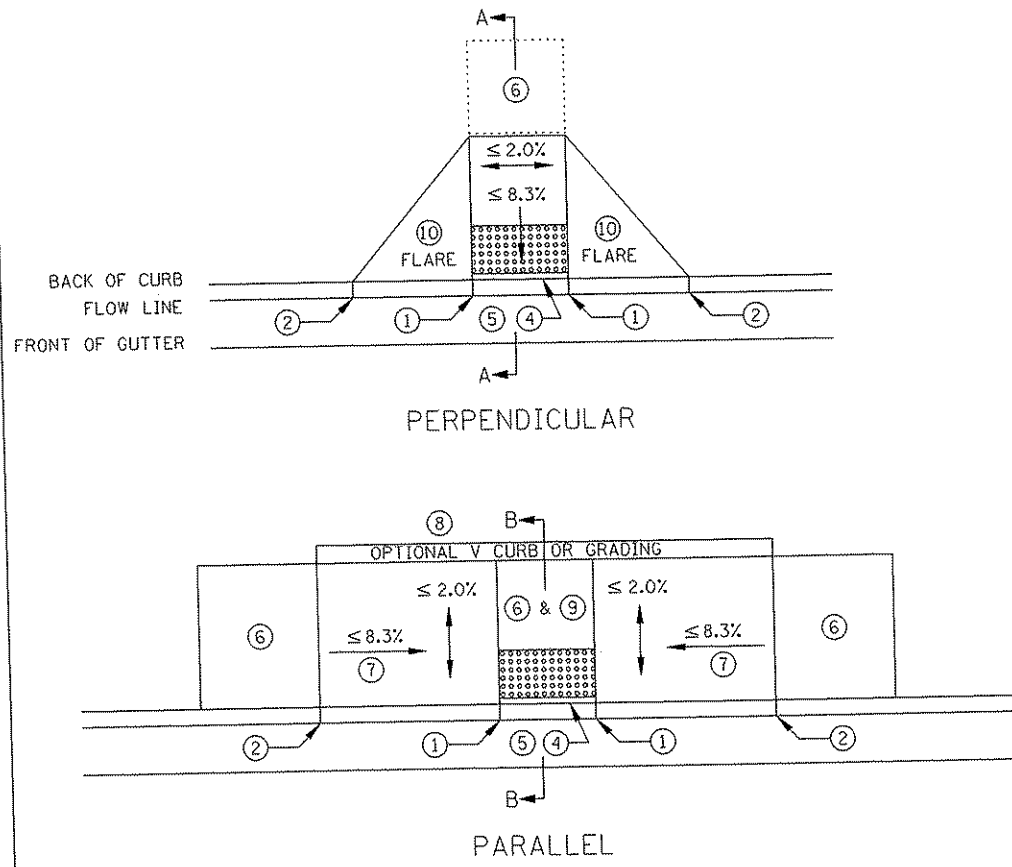

NOTES:

SEE STANDARD PLATE 7038 AND SHEET 4 OF 5 FOR DETAILS ON DETECTABLE WARNING. SLOPES ARE DEFINED AS ABSOLUTE ELEVATION DIFFERENCE PER LENGTH OF RUN. (AS OPPOSED TO A RELATIVE SLOPE WITH RESPECT TO A CURB LINE OR CURB HEIGHT.) LANDINGS SHALL BE LOCATED ANYWHERE THE PEDESTRIAN ACCESS ROUTE CHANGES DIRECTION, AND AT THE TOP OF RAMP THAT HAVE RUNNING SLOPES GREATER THAN 5%. INITIAL CURB RAMP LANDINGS SHALL BE CONSTRUCTED WITHIN 15' FROM THE BACK OF CURB, WITH 6' FROM THE BACK OF CURB BEING THE PREFERRED DISTANCE. SECONDARY CURB RAMP LANDINGS ARE REQUIRED FOR EVERY 30" OF VERTICAL RISE WHEN THE LONGITUDINAL SLOPE IS 5% OR GREATER. CONTRACTION JOINTS SHALL BE CONSTRUCTED AT ALL GRADE BREAKS. TOP OF CURB SHALL MATCH PROPOSED ADJACENT WALK GRADE. USE 6" CONCRETE FOR ALL INITIAL RAMP AND LANDING AREAS. CONTRACTOR SHALL EMPLOY APPROPRIATE METHODS FOR INTERMEDIATE GRADE CONTROL TO ENSURE ALL GRADE BREAKS ARE CONSTRUCTED PROPERLY. ALL GRADE BREAKS SHALL BE PERPENDICULAR TO THE DIRECTION OF TRAVEL/PEDESTRIAN ACCESS ROUTE. 4' MINIMUM WIDTH OF DETECTABLE WARNING IS REQUIRED FOR ALL RAMP. SHARED USE PATHS SHALL HAVE DETECTABLE WARNING ACROSS THE ENTIRE WIDTH OF PATH WHEN THE PATH CROSSES A ROAD.

- ① 0" CURB HEIGHT.
- ② FULL CURB HEIGHT.
- ③ LESS THAN 5% PREFERRED. 5-8.3% SHOULD ONLY BE USED AFTER ALL OTHER SLOPES HAVE BEEN CONSIDERED AND DEEMED IMPRACTICAL.
- ④ 1/2" PREFORMED JOINT FILLER MATERIAL AASHTO M 213. JOINT FILLER SHALL BE PLACED FLUSH WITH THE BACK OF CURB AND ADJACENT SIDEWALK. JOINT SHALL BE FREE OF DEBRIS. RECTANGULAR DETECTABLE WARNINGS SHALL BE SET BACK 3" FROM THE BACK OF CURB. RADIAL DETECTABLE WARNINGS SHALL BE SET BACK 3"-6" FROM THE BACK OF CURB.
- ⑤ SEE PEDESTRIAN ACCESS ROUTE CURB AND GUTTER DETAIL FOR INFORMATION ON CONSTRUCTING CURB AND GUTTER AT CURB OPENINGS. SEE SHEET NO. 3 OF 5.
- ⑥ 4' BY 4' MIN. LANDING WITH MAX. 2% SLOPE IN ALL DIRECTIONS.
- ⑦ IF RUNNING SLOPE IS LESS THAN 5.0% NO SECONDARY LANDING IS REQUIRED.
- ⑧ V CURB, IF USED, SHALL BE PLACED OUTSIDE THE SIDEWALK LIMITS WHEN RIGHT OF WAY ALLOWS. SEE SHEET 5 OF 5.
- ⑨ DETECTABLE WARNINGS MAY BE PART OF 4' X 4' LANDING AREA IF IT IS NOT FEASIBLE TO CONSTRUCT THE LANDING OUTSIDE OF THE DETECTABLE WARNING AREA.
- ⑩ SEE SHEET 4 OF 5, TYPICAL SIDE TREATMENT OPTIONS, FOR DETAILS ON FLARES AND RETURNED CURBS.
- ⑪ SEE SHEET 3 OF 5 FOR FURTHER DETAIL.
- ⑫ DIAGONAL RAMPS SHOULD ONLY BE USED AFTER ALL OTHER CURB RAMP TYPES HAVE BEEN CONSIDERED AND DEEMED IMPRACTICAL.

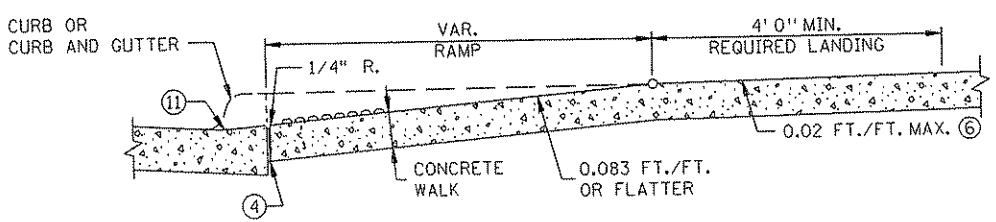

SECTION A-A  
 PERPENDICULAR/TIERED/DIAGONAL/FAN

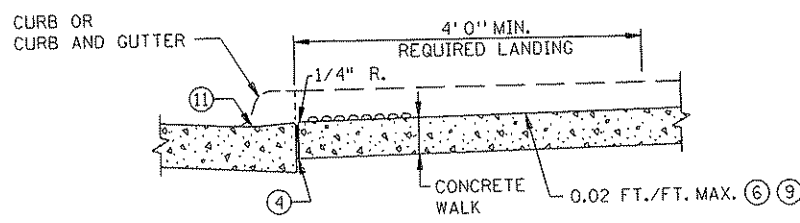

SECTION B-B  
 PARALLEL/DEPRESSED CORNER

STANDARD PLAN SHEET NO. 5-297.250 (1 OF 5)	PEDESTRIAN CURB RAMP DETAILS
STANDARD APPROVED: MAY 10, 2012	
S.A.P. 002-716-013	S.P. 0208-145 (T.H. 65)
S.A.P. 197-020-004	SHEET NO. 13 OF 108 SHEETS

PLOTTED/REVISED:  
 \$\$\$DATE\$\$\$

DISTRICT #: \$\$\$DISTRICT\$\$\$  
 USER NAME: \$\$\$USER\$\$\$  
 PATH & FILENAME: \$\$\$PATH\$\$\$

FILE NAME:  
 @FILENAME@

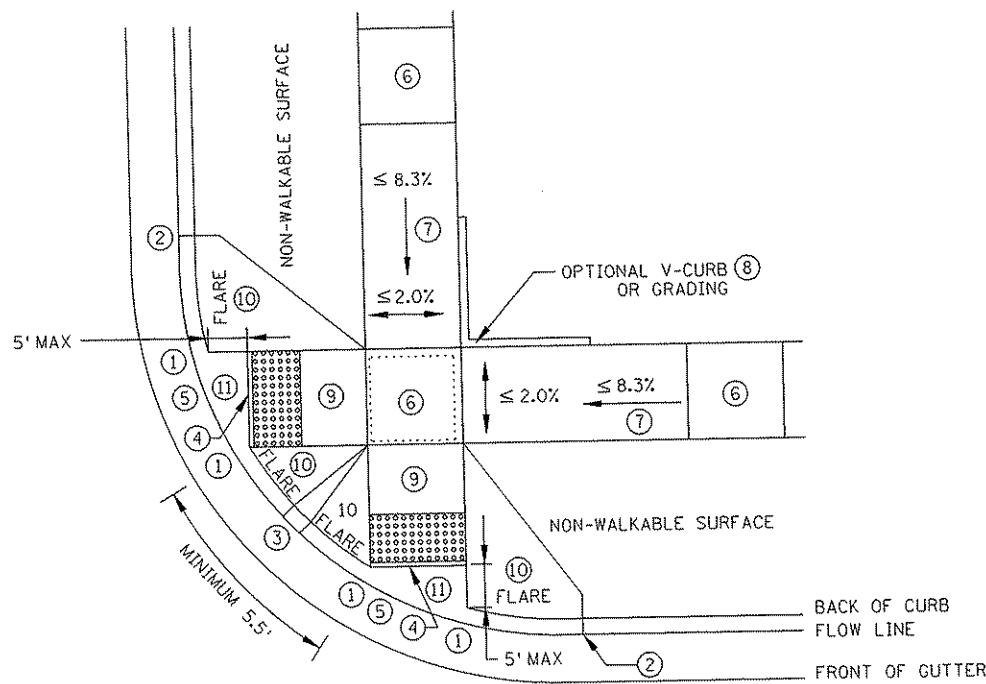

ADJACENT TO NON-WALKABLE SURFACE

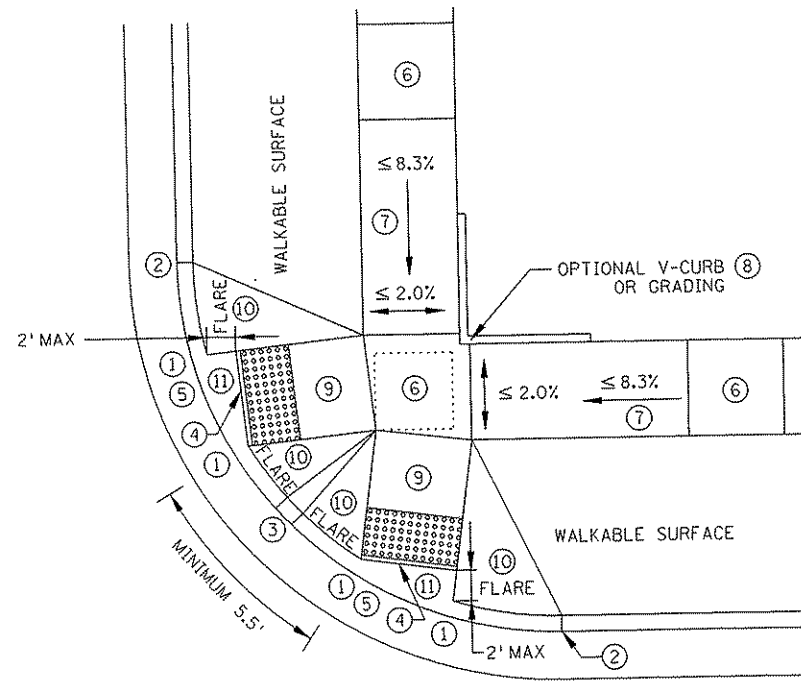

ADJACENT TO WALKABLE SURFACE

COMBINED DIRECTIONAL

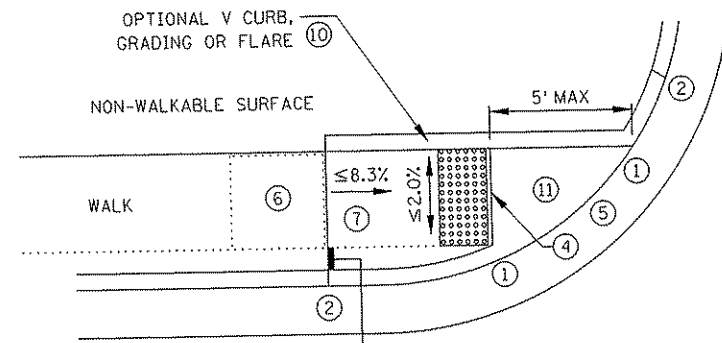

IF NON-CONCRETE BLVD. IS CONSTRUCTED AND IS LESS THAN 2' IN WIDTH AT TOP OF CURB TRANSITION, PAVE CONCRETE RAMP WIDTH TO ADJACENT BACK OF CURB.

ONE-WAY DIRECTIONAL

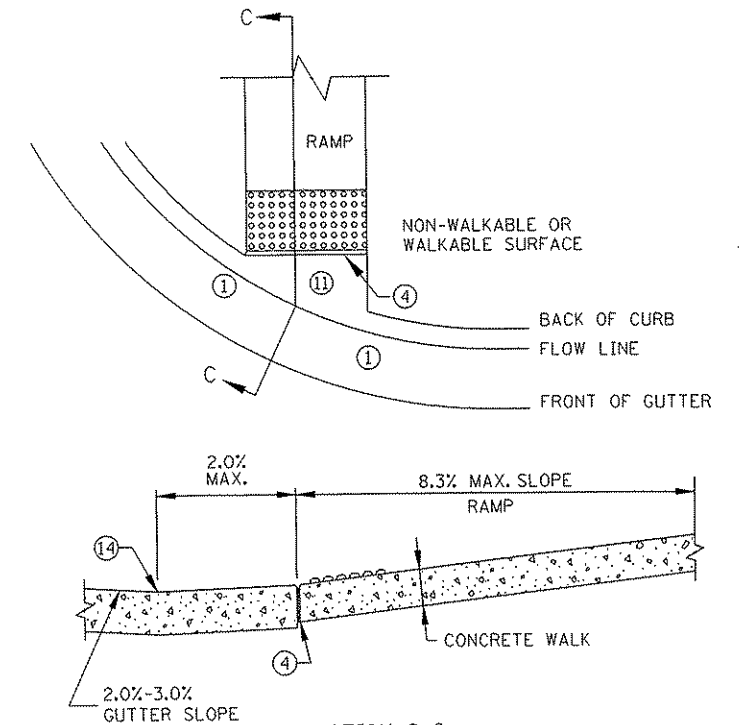
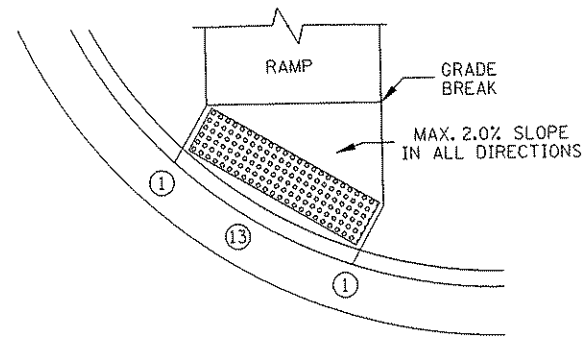

SECTION C-C  
 CURB FOR DIRECTIONAL RAMPS

- NOTES:
- SEE STANDARD PLATE 7038 AND SHEET 4 OF 5 FOR DETAILS ON DETECTABLE WARNING.
  - SLOPES ARE DEFINED AS ABSOLUTE ELEVATION DIFFERENCE PER LENGTH OF RUN. (AS OPPOSED TO A RELATIVE SLOPE WITH RESPECT TO A CURB LINE OR CURB HEIGHT.)
  - LANDINGS SHALL BE LOCATED ANYWHERE THE PEDESTRIAN ACCESS ROUTE CHANGES DIRECTION, AND AT THE TOP OF RAMPS THAT HAVE RUNNING SLOPES GREATER THAN 5%.
  - INITIAL CURB RAMP LANDINGS SHALL BE CONSTRUCTED WITHIN 15' FROM THE BACK OF CURB, WITH 6' FROM THE BACK OF CURB BEING THE PREFERRED DISTANCE.
  - SECONDARY CURB RAMP LANDINGS ARE REQUIRED FOR EVERY 30" OF VERTICAL RISE WHEN THE LONGITUDINAL SLOPE IS 5% OR GREATER.
  - CONTRACTION JOINTS SHALL BE CONSTRUCTED AT ALL GRADE BREAKS.
  - TOP OF CURB SHALL MATCH PROPOSED ADJACENT WALK GRADE.
  - USE 6" CONCRETE WALK FOR ALL INITIAL RAMP AND LANDING AREAS.
  - CONTRACTOR SHALL EMPLOY APPROPRIATE METHODS FOR INTERMEDIATE GRADE CONTROL TO ENSURE ALL GRADE BREAKS ARE CONSTRUCTED PROPERLY.
  - ALL GRADE BREAKS SHALL BE PERPENDICULAR TO THE DIRECTION OF TRAVEL/PEDESTRIAN ACCESS ROUTE.
  - 4' MINIMUM WIDTH OF DETECTABLE WARNING IS REQUIRED FOR ALL RAMPS. SHARED USE PATHS SHALL HAVE DETECTABLE WARNING ACROSS THE ENTIRE WIDTH OF PATH WHEN THE PATH CROSSES A ROAD.
  - 1 0" CURB HEIGHT.
  - 2 FULL CURB HEIGHT.
  - 3 3" MINIMUM CURB HEIGHT.
  - 4 1/2" PREFORMED JOINT FILLER MATERIAL AASHTO M 213. JOINT FILLER SHALL BE PLACED FLUSH WITH THE BACK OF CURB AND ADJACENT SIDEWALK. JOINT SHALL BE FREE OF DEBRIS. RECTANGULAR DETECTABLE WARNINGS SHALL BE SET BACK 3" FROM THE BACK OF CURB. RADIAL DETECTABLE WARNINGS SHALL BE SET BACK 3"-6" FROM THE BACK OF CURB.
  - 5 SEE PEDESTRIAN ACCESS ROUTE CURB AND GUTTER DETAIL FOR INFORMATION ON CONSTRUCTING CURB AND GUTTER AT CURB OPENINGS. SEE SHEET NO. 3 OF 5.
  - 6 4' BY 4' MIN. LANDING WITH MAX. 2% SLOPE IN ALL DIRECTIONS.
  - 7 IF RAMP SLOPE IS LESS THAN 5% NO SECONDARY LANDING IS REQUIRED.
  - 8 V CURB, IF USED, SHALL BE PLACED OUTSIDE THE SIDEWALK LIMITS WHEN RIGHT OF WAY ALLOWS.
  - 9 RUNNING SLOPE LESS THAN OR EQUAL TO 8.3% & CROSS SLOPE LESS THAN OR EQUAL TO 2%.
  - 10 SEE SHEET 4 OF 5, TYPICAL SIDE TREATMENT OPTIONS, FOR DETAILS ON FLARES AND RETURNED CURBS.
  - 11 MAX. 2% SLOPE IN ALL DIRECTIONS IN FRONT OF GRADE BREAK AND DRAIN TO FLOW LINE. SHALL BE CONSTRUCTED INTEGRAL WITH CURB AND GUTTER.
  - 12 TO BE USED FOR ALL DIRECTIONAL RAMPS.
  - 13 DOMES PLACED AT THE BACK OF CURB WHEN ALLOWABLE SETBACK CRITERIA IS EXCEEDED.
  - 14 ANY VERTICAL LIP THAT OCCURS AT THE FLOW LINE MAY NOT BE GREATER THAN 1/4 INCH.

STANDARD PLAN SHEET NO. 5-297.250 (2 OF 5)	PEDESTRIAN CURB RAMP DETAILS		
STANDARD APPROVED: MAY 10, 2012			
S.A.P. 002-716-013	S.P. 0208-145 (T.H. 65)	S.A.P. 197-020-004	SHEET NO. 14 OF 108 SHEETS

PLOTTED/REVISED: \$\$\$@DATE@\$\$\$

DISTRICT #: \$\$\$@DISTRICT@\$\$  
 USER NAME: \$\$\$@USER\$NAME@\$\$\$  
 PATH & FILENAME: \$\$\$@PATH\$FILENAME@\$\$\$

FILE NAME: \$\$\$@FILENAME@\$\$\$

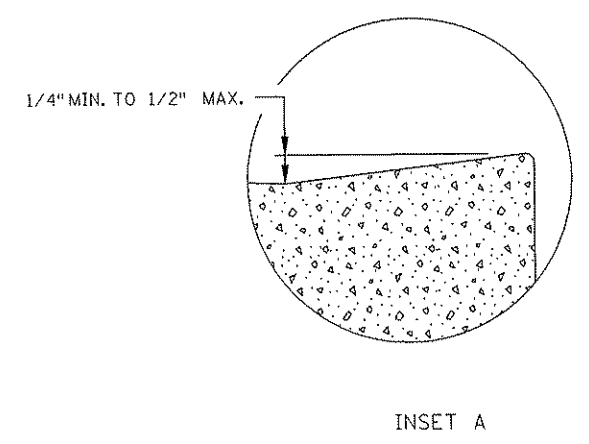
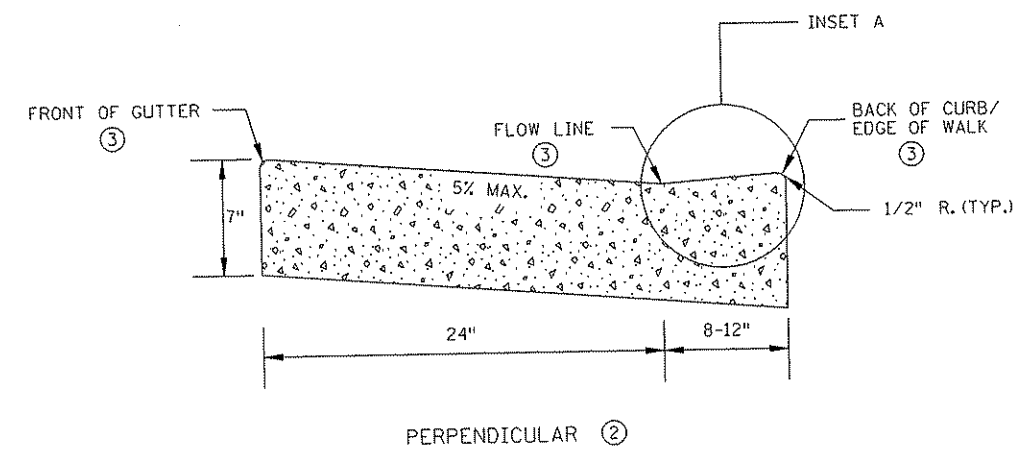
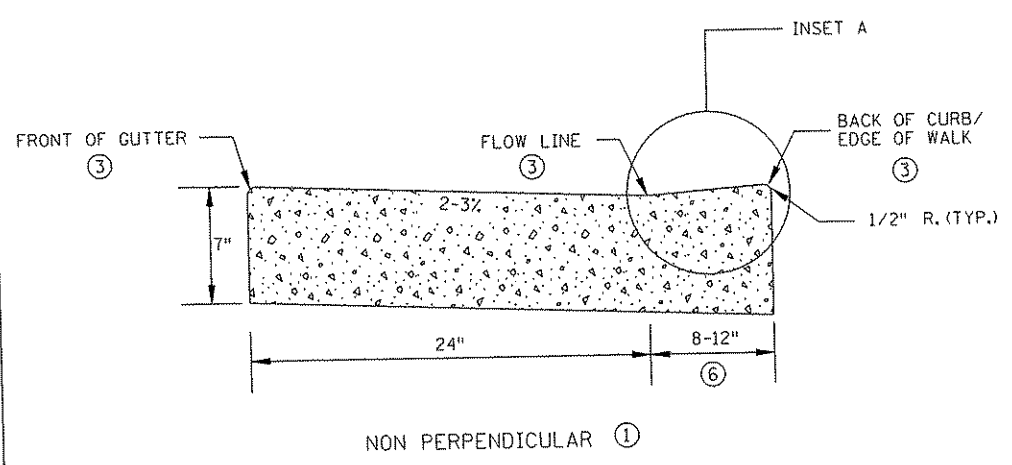

PEDESTRIAN ACCESS ROUTE  
CURB & GUTTER DETAIL

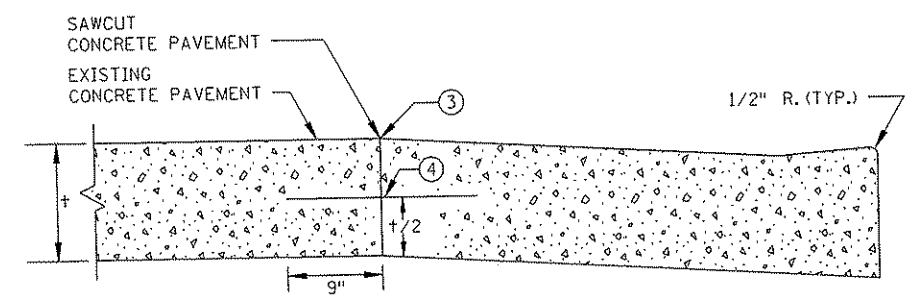
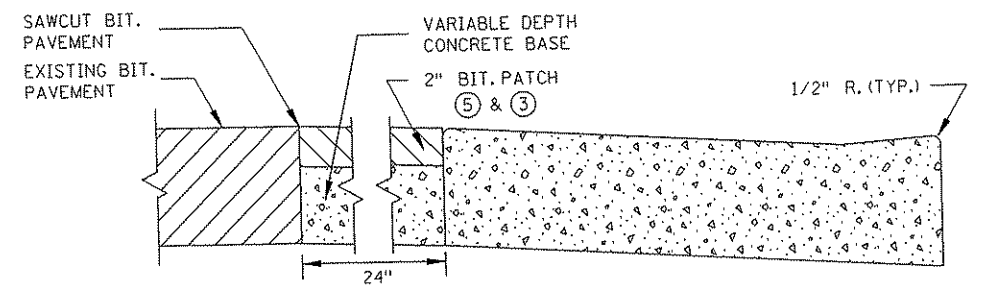
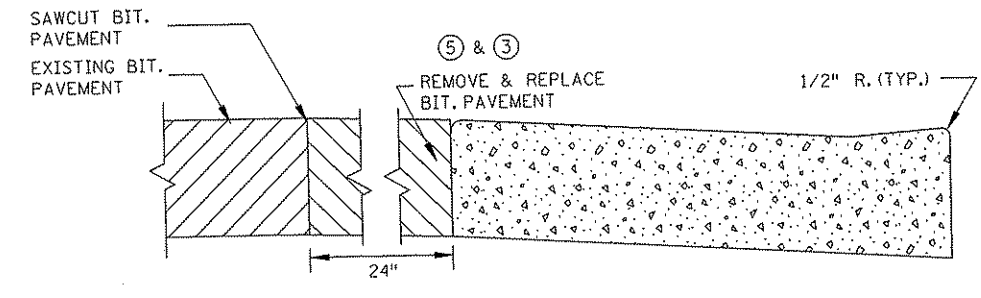
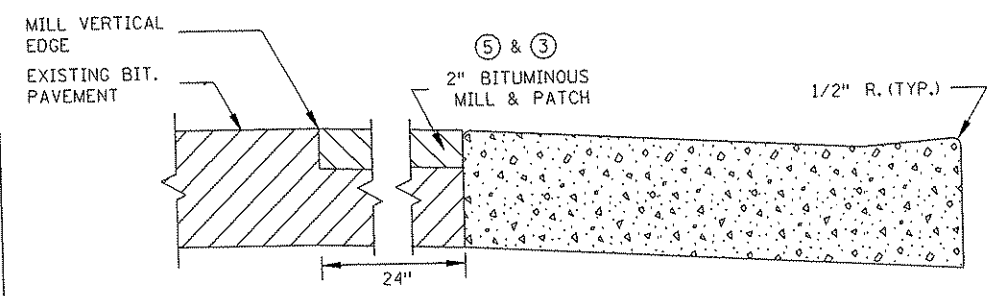

PAVEMENT TREATMENT OPTIONS  
IN FRONT OF CURB & GUTTER  
FOR USE ON CURB RAMP RETROFITS

- NOTES:  
 ADEQUATE DRAINAGE SHALL BE MAINTAINED THROUGHOUT THE PEDESTRIAN ACCESS ROUTE (PAR) AT A 2% ABSOLUTE MAXIMUM.  
 NO PONDING SHALL BE PRESENT IN THE PAR.  
 ANY VERTICAL LIP THAT OCCURS AT THE FLOW LINE MAY NOT BE GREATER THAN 1/4 INCH.
- ① FOR USE AT CURB CUTS WHERE THE PEDESTRIAN'S PATH OF TRAVEL IS ASSUMED NON PERPENDICULAR TO THE GUTTER FLOW LINE. RAMP TYPES INCLUDE: FANS, DEPRESSED CORNERS, & ONE WAY AND COMBINED DIRECTIONALS.
  - ② FOR USE AT CURB CUTS WHERE THE PEDESTRIAN'S PATH OF TRAVEL IS ASSUMED PERPENDICULAR TO THE GUTTER FLOW LINE. RAMP TYPES INCLUDE: PERPENDICULAR, TIERED PERPENDICULAR, PARALLEL, AND DIAGONAL RAMPS.
  - ③ THERE SHALL BE NO VERTICAL DISCONTINUITIES GREATER THAN 1/4".
  - ④ DRILL AND GROUT NO. 13 EPOXY-COATED 18" LONG BARS AT 2' CENTER TO CENTER INTO EXISTING CONCRETE PAVEMENT.
  - ⑤ ELEVATION CHANGE TAKES PLACE FROM THE EXISTING TO NEW FRONT OF GUTTER. PATCH IS USED TO MATCH THE NEW GUTTER FACE INTO THE EXISTING ROADWAY.
  - ⑥ VARIABLE WIDTH FOR DIRECTIONAL CURB APPLICATIONS.

STANDARD PLAN SHEET NO. 5-297.250 (3 OF 5)	PEDESTRIAN CURB RAMP DETAILS
STANDARD APPROVED: MAY 10, 2012	
S.A.P. 002-716-013	S.P. 0208-145 (T.H. 65) S.A.P. 197-020-004 SHEET NO. 15 OF 108 SHEETS

PLOTTED/REVISED:  
 \$\$\$DATE\$\$\$

DISTRICT #: \$DISTRICT\$  
 USER NAME: \$USER\$NAME\$  
 PATH & FILENAME: \$\$\$PATHFILENAME\$\$\$

FILE NAME:  
 @FILENAME@

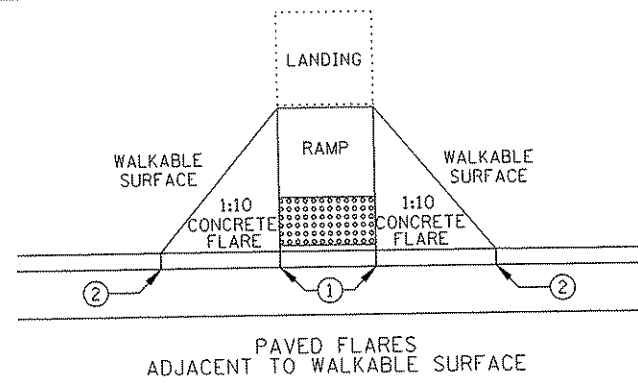

PAVED FLARES  
 ADJACENT TO WALKABLE SURFACE

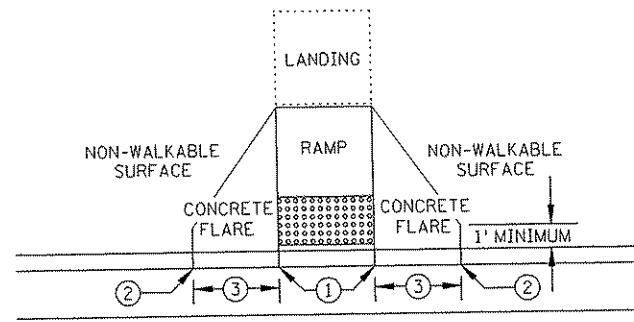

PAVED FLARES  
 ADJACENT TO NON-WALKABLE SURFACE

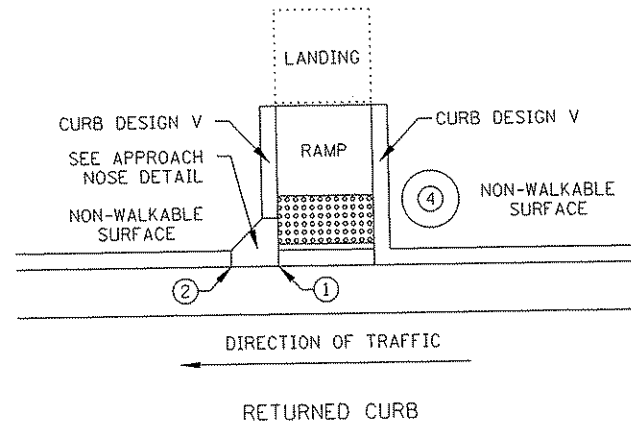

DIRECTION OF TRAFFIC

RETURNED CURB

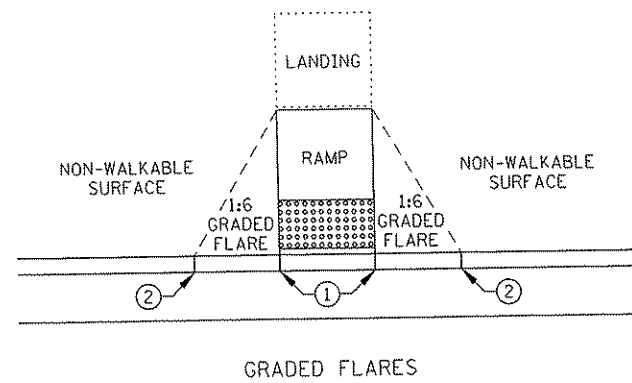

GRADED FLARES

TYPICAL SIDE TREATMENT OPTIONS ⑤

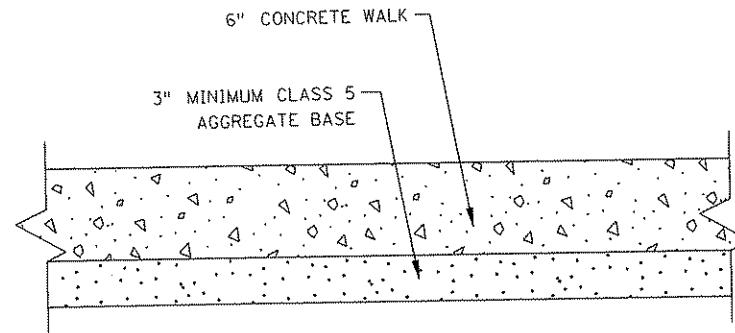

TYPICAL SIDEWALK SECTION  
 WITHIN INTERSECTION CORNER

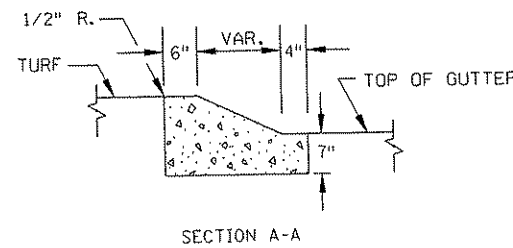
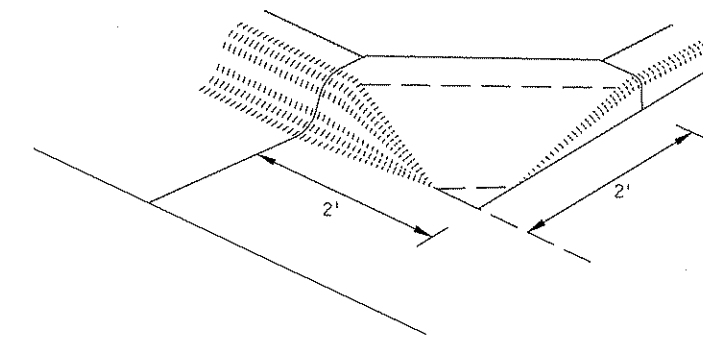

APPROACH NOSE DETAIL  
 FOR DOWNSTREAM SIDE OF TRAFFIC

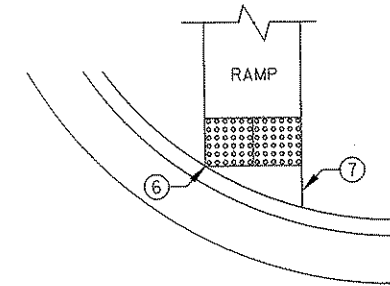

DETECTABLE WARNING  
 SETBACK CRITERIA

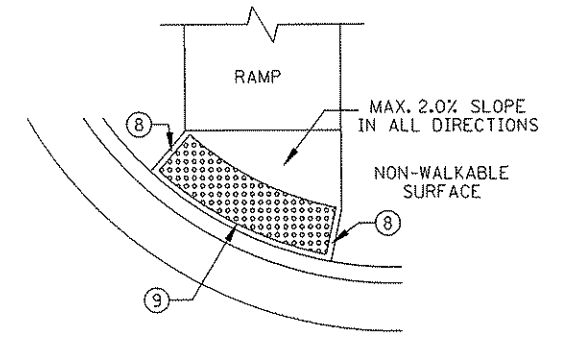

RADIAL DETECTABLE  
 WARNING AT RADIUS

DETECTABLE WARNING PLACEMENT

NOTES:

SEE STANDARD PLATE 7038 AND THIS SHEET FOR DETAILS ON DETECTABLE WARNING.  
 USE 6" CONCRETE WALK UP TO EXISTING SIDEWALK GRADES FOR ALL RAMP AND LANDING AREAS.  
 WHETHER A SURFACE IS WALKABLE OR NOT SHALL BE DETERMINED BY THE ENGINEER.  
 FLARE LENGTHS SHOULD BE LESS THAN 8' LONG MEASURED ALONG THE RAMPS FROM THE BACK OF CURB.

4' MINIMUM WIDTH OF DETECTABLE WARNING IS REQUIRED FOR ALL RAMPS. SHARED USE PATHS SHALL HAVE DETECTABLE WARNING ACROSS THE ENTIRE WIDTH OF PATH WHEN THE PATH CROSSES A ROAD.

- ① 0" CURB HEIGHT.
- ② FULL CURB HEIGHT.
- ③ 2' - 3' CONCRETE FLARE.
- ④ IMMOVABLE OBJECT OR OBSTRUCTION.
- ⑤ SIDE TREATMENTS ARE APPLICABLE TO ALL RAMP TYPES AND SHOULD BE IMPLEMENTED AS NEEDED ON ALL RAMPS AS FIELD CONDITIONS DICTATE. THE ENGINEER SHALL DETERMINE THE RAMP SIDE TREATMENTS BASED ON MAINTENANCE OF BOTH ROADWAY AND SIDEWALK, ADJACENT PROPERTY CONSIDERATIONS, AND MITIGATING CONSTRUCTION IMPACTS.
- ⑥ DETECTABLE WARNING SHALL HAVE ONE CORNER 3" FROM THE BACK OF CURB.
- ⑦ SHALL BE 2' MAXIMUM OFFSET WHEN ADJACENT TO WALKABLE SURFACE AND 5' MAXIMUM OFFSET WHEN ADJACENT TO NON-WALKABLE SURFACE.
- ⑧ WHEN NO FLARES ARE PROPOSED, THE CONCRETE WALK SHALL BE FORMED AND CONSTRUCTED PERPENDICULAR TO THE BACK OF CURB. MAINTAIN 3" BETWEEN EDGE OF DOMES AND EDGE OF CONCRETE.
- ⑨ DETECTABLE WARNING TO BE PLACED AT A UNIFORM OFFSET DISTANCE FROM 3" TO 6" FROM THE BACK OF CURB. IF NO CURB AND GUTTER IS PLACED IN RURAL SECTIONS, DETECTABLE WARNING SHALL BE PLACED 1' FROM THE EDGE OF ROADWAY TO PROVIDE CONCRETE BORDER.

STANDARD PLAN SHEET NO.  
 5-297.250 (4 OF 5)  
 STANDARD APPROVED:  
 MAY 10, 2012

PEDESTRIAN CURB RAMP DETAILS



PLOTTED/REVISED:  
 \$\$\$@DATE\$\$\$

DISTRICT #: \$\$\$@DISTRICT@  
 USER NAME: \$\$\$@USER\$NAME\$\$\$  
 PATH & FILENAME: \$\$\$@PATH\$FILENAME\$\$\$

FILE NAME:  
 @FILENAME@

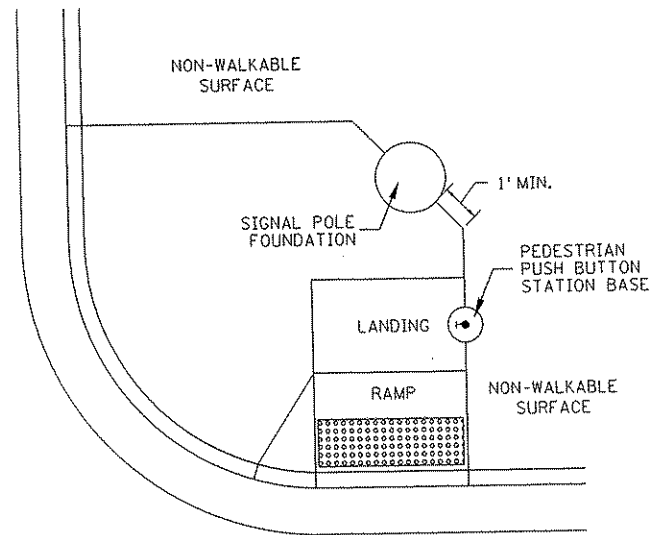

CONCRETE WALK EDGES ADJACENT TO CONCRETE STRUCTURES

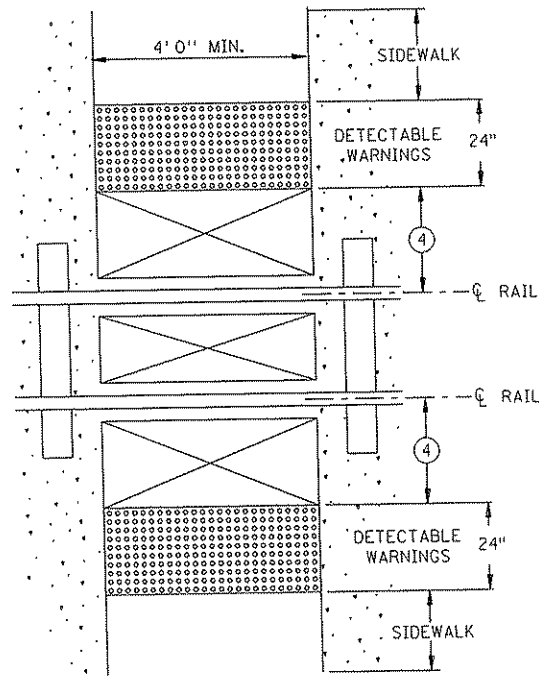

RAILROAD CROSSING PLAN VIEW

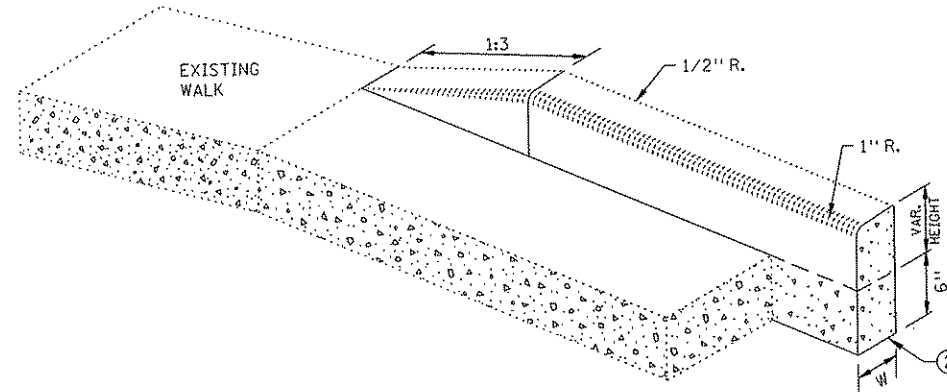

V CURB ADJACENT TO LANDSCAPE CURB WITHIN SIDEWALK LIMITS

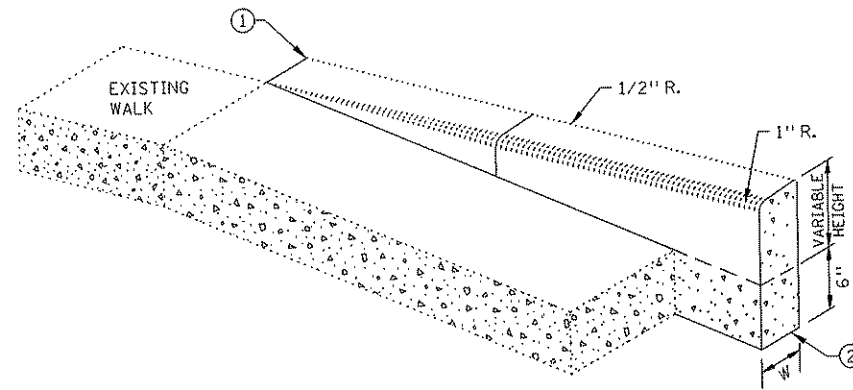

V CURB ADJACENT TO LANDSCAPE CURB OUTSIDE SIDEWALK LIMITS

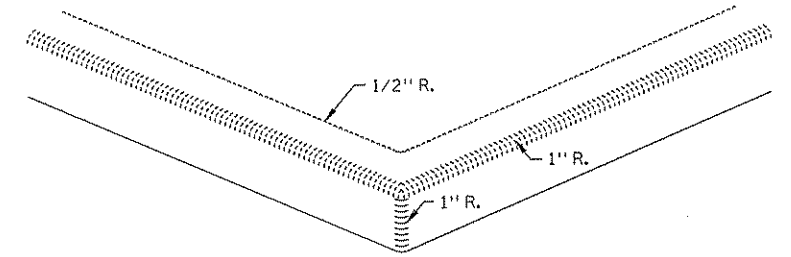

V CURB INTERSECTION

CONCRETE CURB DESIGN V	
CURB HEIGHT H	CURB WIDTH W
< 6"	4"
≥ 6"	6"

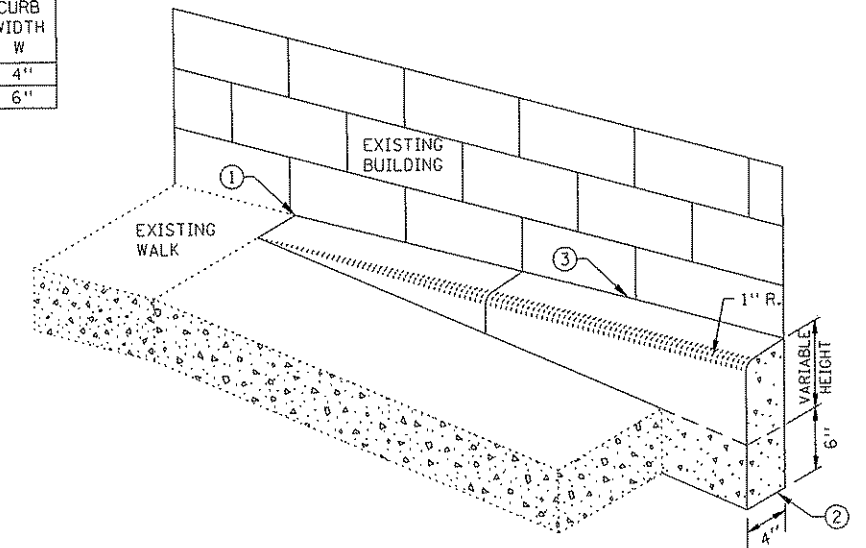

V CURB ADJACENT TO BUILDING

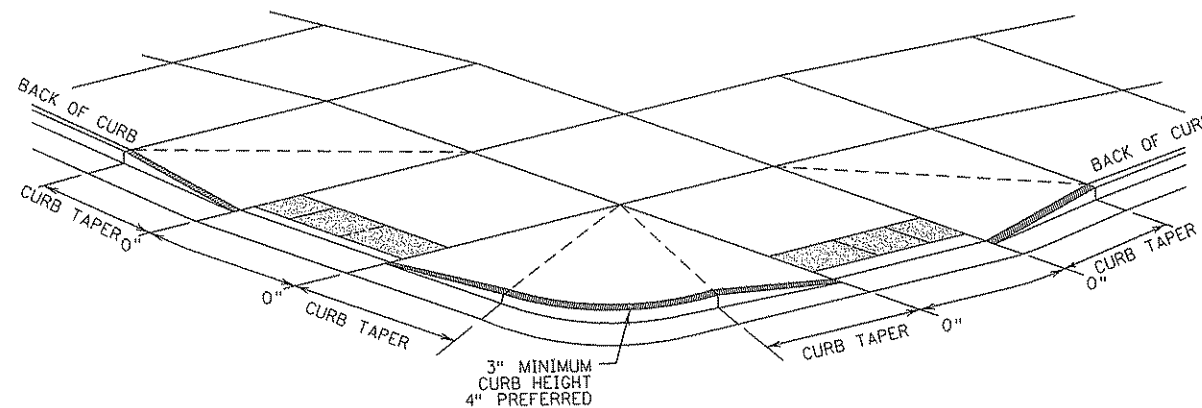

DETECTABLE EDGE AT QUADRANT ⑤

NOTES:

- ALL V-CURB CONTRACTION JOINTS SHALL MATCH CONCRETE WALK JOINTS.
- V CURB SHALL BE PLACED OUTSIDE THE SIDEWALK LIMITS WHEN RIGHT OF WAY ALLOWS.
- V CURB NEXT TO BUILDING SHALL BE A 4" WIDTH AND SHALL MATCH PREVIOUS TOP OF SIDEWALK ELEVATIONS.
- ① END TAPERS AT TRANSITION SECTION SHALL MATCH INPLACE SIDEWALK GRADES.
- ② ALL V CURB SHALL MATCH BOTTOM OF ADJACENT WALK.
- ③ EDGE BETWEEN NEW V CURB AND INPLACE STRUCTURE SHALL BE SEALED AND BOND BREAKER SHALL BE USED BETWEEN EXISTING STRUCTURE AND PLACED V-CURB.
- ④ EDGE OF DETECTABLE WARNING SURFACES SHALL BE PLACED 6' MINIMUM TO 15' MAXIMUM FROM THE CENTERLINE OF THE NEAREST RAIL. WHEN PEDESTRIAN GATES ARE PROVIDED, DETECTABLE WARNING SURFACES SHALL BE PLACED ON THE SIDE OF THE GATES OPPOSITE THE RAIL.
- ⑤ ALL CONSTRUCTED CURBS MUST HAVE A CONTINUOUS DETECTABLE EDGE FOR THE VISUALLY IMPAIRED. THIS DETECTABLE EDGE REQUIRES TRUNCATED DOMES WHEREVER THERE IS ZERO-INCH HIGH CURB. CURB TRANSITIONS ARE CONSIDERED A DETECTABLE EDGE WHEN THE TAPER STARTS IMMEDIATELY AT THE EDGE OF THE TRUNCATED DOMES AND UNIFORMLY RISES TO A 3-INCH MINIMUM CURB HEIGHT. ANY CURB NOT PART OF A CURB TRANSITION AND LESS THAN 3 INCHES IN HEIGHT IS NOT CONSIDERED A DETECTABLE EDGE AND THEREFORE IS NOT COMPLIANT WITH ACCESSIBILITY GUIDELINES.

STANDARD PLAN SHEET NO.  
 5-297.250 (5 OF 5)  
 STANDARD APPROVED:  
 MAY 10, 2012

PEDESTRIAN CURB RAMP DETAILS

NOTES:

- ③ SALVAGE FOR RE-USE ON THIS PROJECT
- ⑤ SALVAGE TO ANOKA COUNTY
- ⑥ SALVAGE TO MNDOT
- ⑨ RETAIN INPLACE SIGN

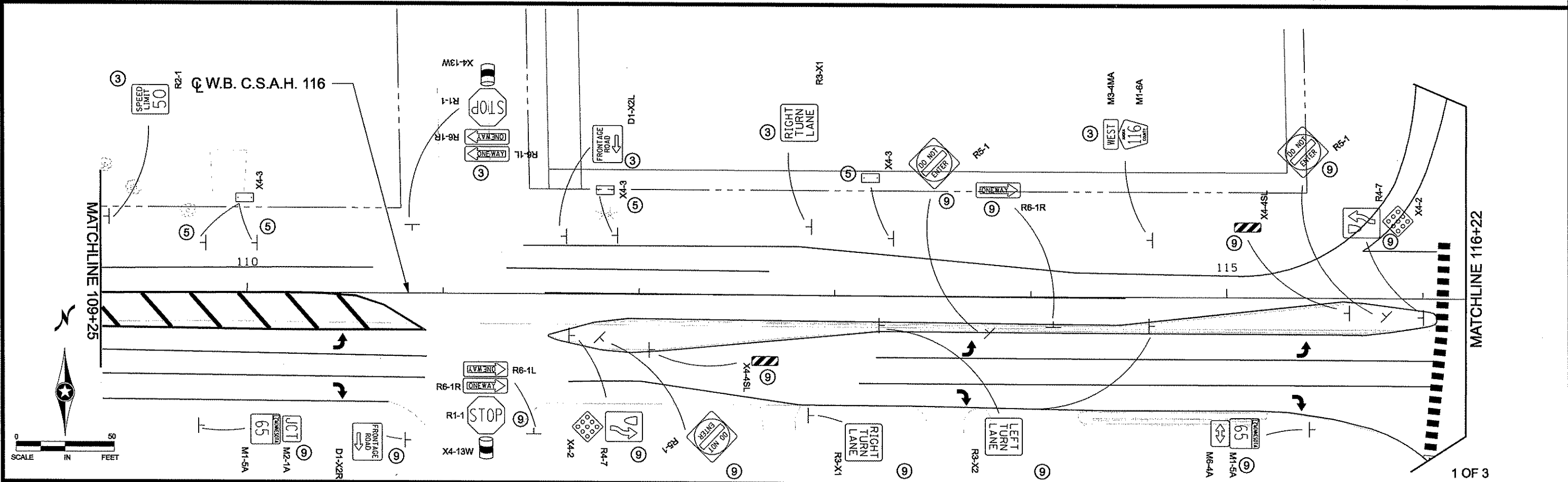
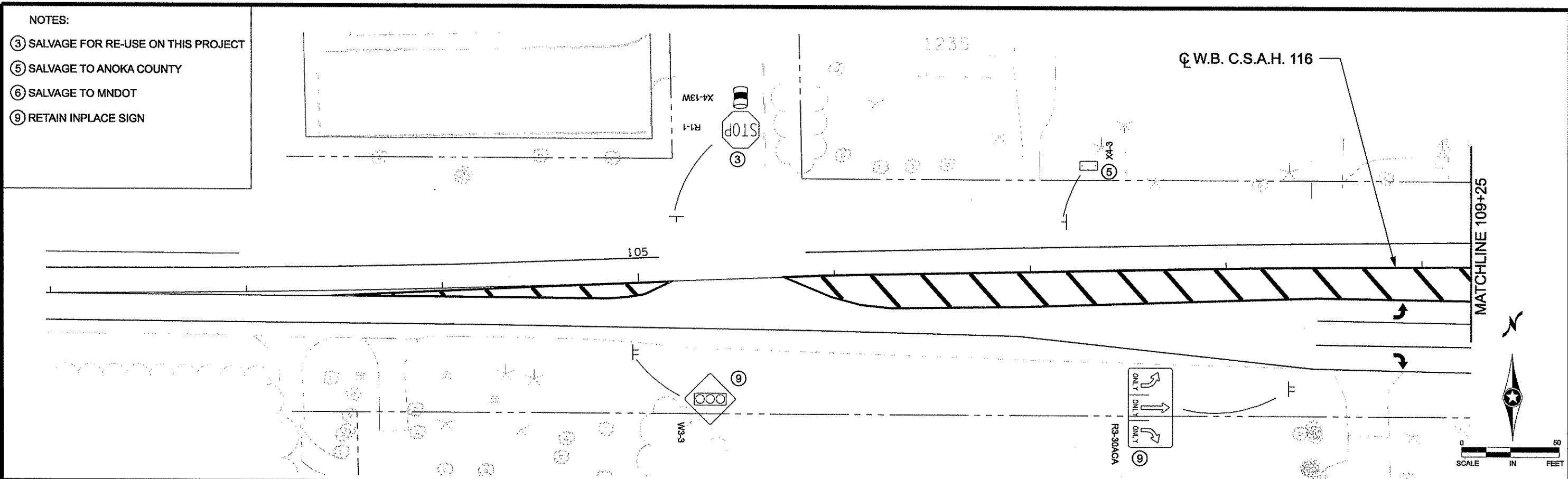

NO	DATE	BY	CHKD	APPR	REVISION
NAME: px116-65\plan116-65_INPSTP_P1.dgn					

I HEREBY CERTIFY THAT THIS PLAN WAS PREPARED BY ME OR UNDER MY DIRECT SUPERVISION AND THAT I AM A DULY LICENSED PROFESSIONAL ENGINEER UNDER THE LAWS OF THE STATE OF MINNESOTA.  
 PRINT NAME: Curt Koblarscik  
 SIGNATURE: [Signature]  
 DATE: 6-27-12 LICENSE NO. 24758

DRAWN BY: DFP DATE: 03-20-12  
 DESIGN BY: DFP DATE: 03-20-12  
 CHECKED BY: JKR DATE: 03-30-12

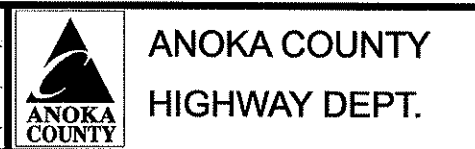

S.P. 0208-145 (T.H. 65)  
 S.A.P. 002-716-013  
 S.A.P. 197-020-004

INPLACE SIGNING AND STRIPING PLAN  
 STA 102+00 TO 116+50  
 Sheet 18 of 108 Sheets

NOTES:

- ③ SALVAGE FOR RE-USE ON THIS PROJECT
- ⑤ SALVAGE TO ANOKA COUNTY
- ⑥ SALVAGE TO MNDOT
- ⑨ RETAIN INPLACE SIGN

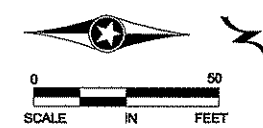
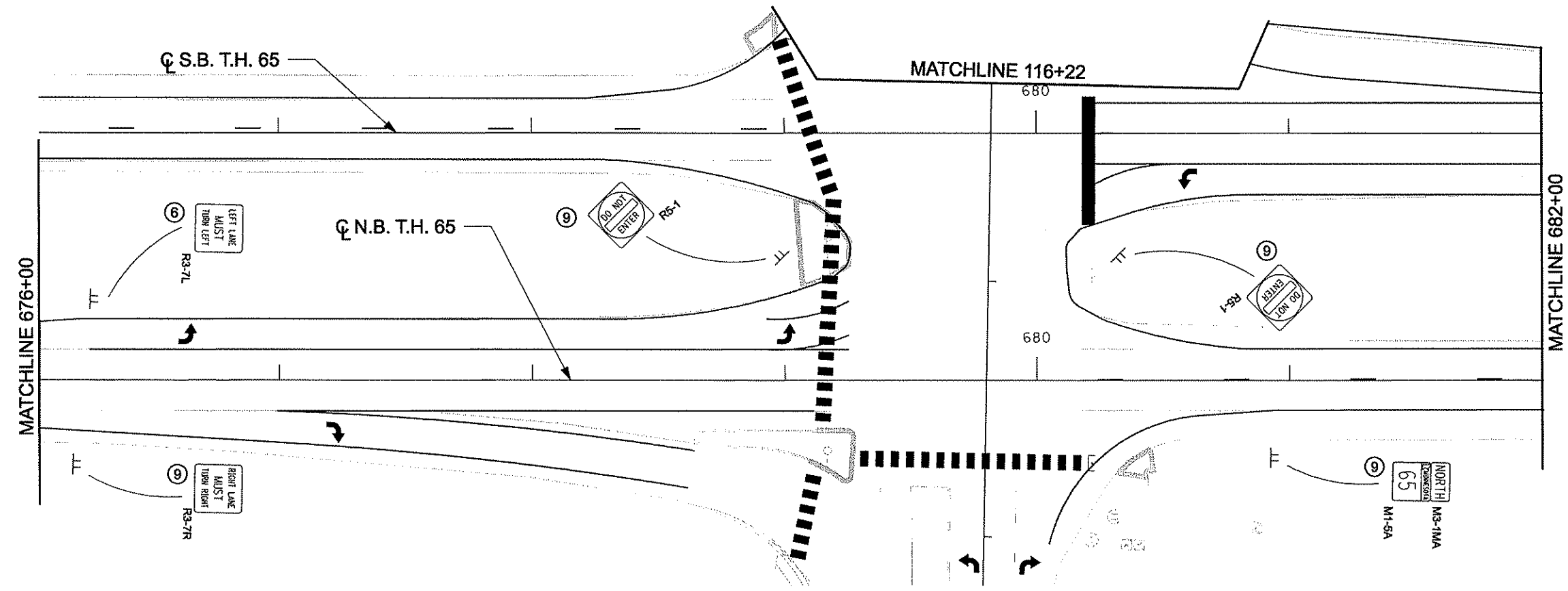
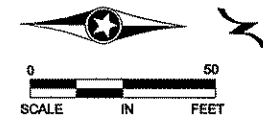
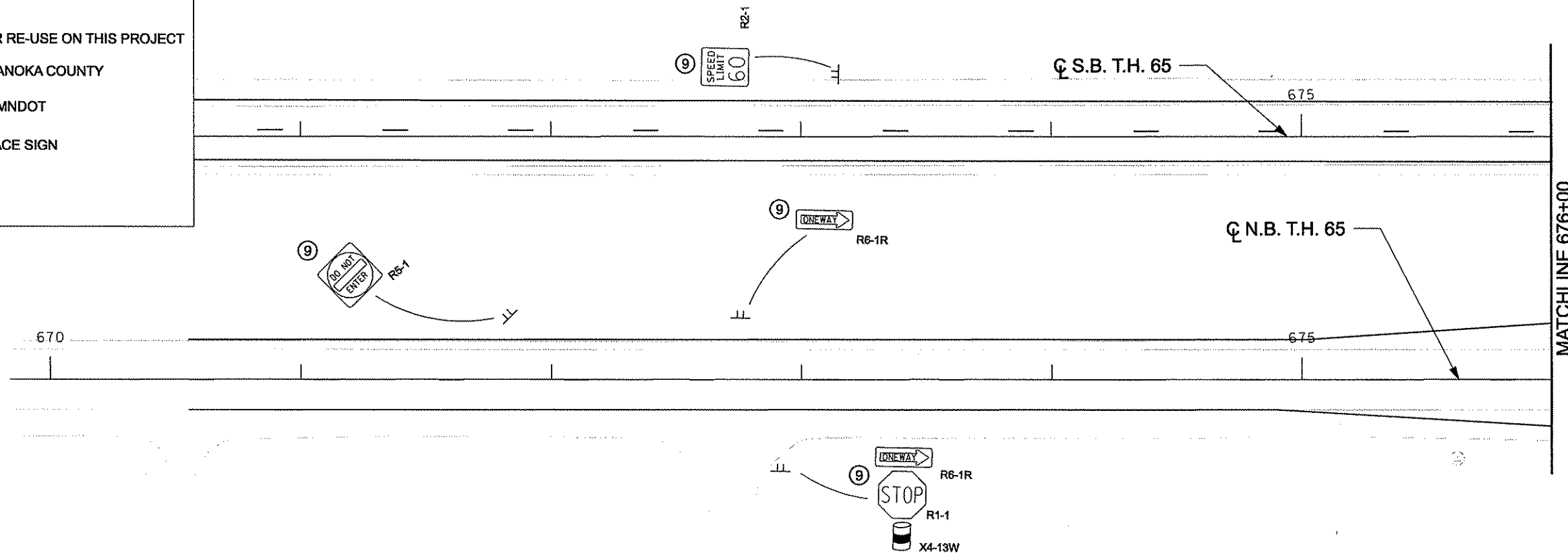

2 OF 3

NO	DATE	BY	CHKD	APPR	REVISION
NAME: pt118-65\plan118-65_INPSTP_P2.dgn					
08/26/2012 11:41:20 AM					

I HEREBY CERTIFY THAT THIS PLAN WAS PREPARED BY ME OR UNDER MY DIRECT SUPERVISION AND THAT I AM A DULY LICENSED PROFESSIONAL ENGINEER UNDER THE LAWS OF THE STATE OF MINNESOTA.  
 PRINT NAME: Curt Kobilarcik  
 SIGNATURE: *Curt Kobilarcik*  
 DATE: 6-27-12 LICENSE NO. 24758

DRAWN BY DFP DATE 03-20-12  
 DESIGN BY DFP DATE 03-20-12  
 CHECKED BY JKR DATE 03-30-12



S.P. 0208-145 (T.H. 65)  
 S.A.P. 002-716-013  
 S.A.P. 197-020-004

INPLACE SIGNING AND STRIPING PLAN  
 STA 670+00 TO 682+00  
 Sheet 19 of 108 Sheets

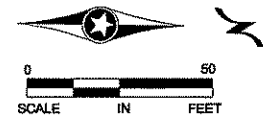
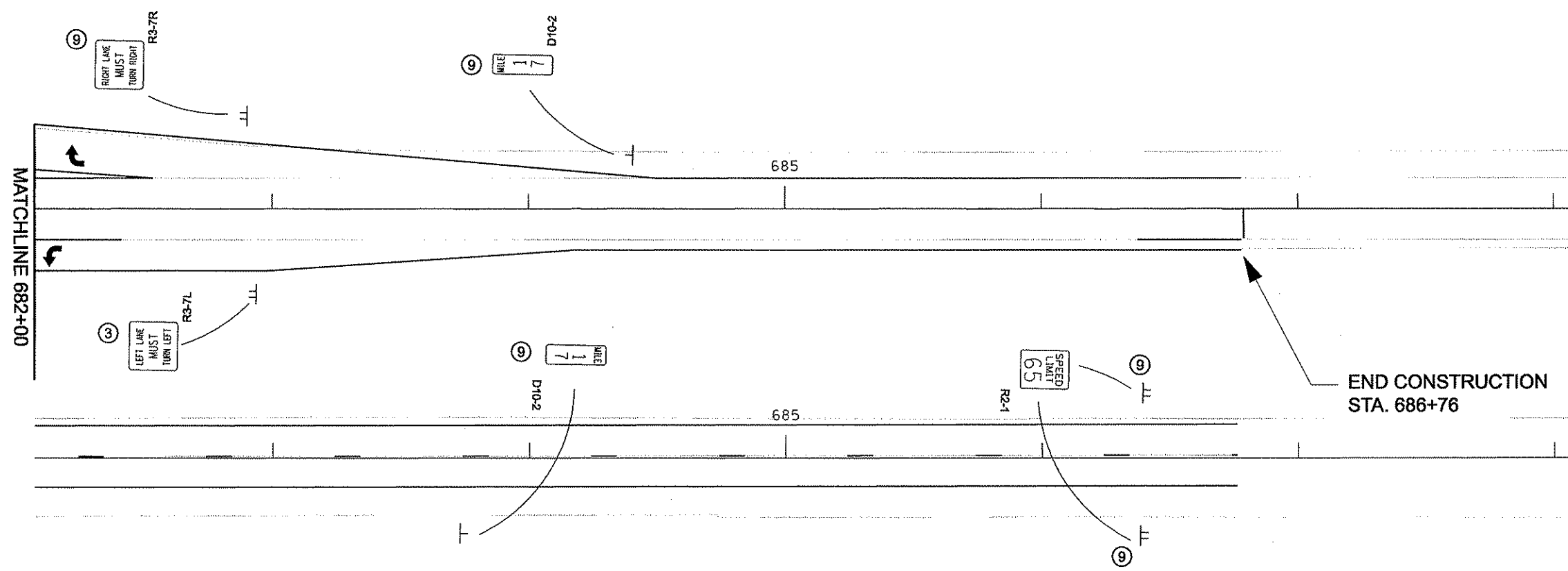

NOTES:

- ③ SALVAGE FOR RE-USE ON THIS PROJECT
- ⑤ SALVAGE TO ANOKA COUNTY
- ⑥ SALVAGE TO MNDOT
- ⑨ RETAIN INPLACE SIGN

NO	DATE	BY	CHKD	APPR	REVISION

NAME: p:\116-65\plan\116-65\_INPSTP\_P3.dgn      08/28/2012      11:41:22 AM

I HEREBY CERTIFY THAT THIS PLAN WAS PREPARED BY ME OR UNDER MY DIRECT SUPERVISION AND THAT I AM A DULY LICENSED PROFESSIONAL ENGINEER UNDER THE LAWS OF THE STATE OF MINNESOTA.

PRINT NAME: Curt Koblarcsik

SIGNATURE: *Curt Koblarcsik*

DATE: 6-27-12 LICENSE NO. 24756

DRAWN BY DFP DATE 03-20-12

DESIGN BY DFP DATE 03-20-12

CHECKED BY JKR DATE 03-30-12



S.P. 0208-145 (T.H. 65)

S.A.P. 002-716-013

S.A.P. 197-020-004

INPLACE SIGNING AND STRIPING PLAN

STA 682+00 TO 686+79

Sheet 20 of 108 Sheets

**CONCRETE DRAINAGE FLUME DETAIL**

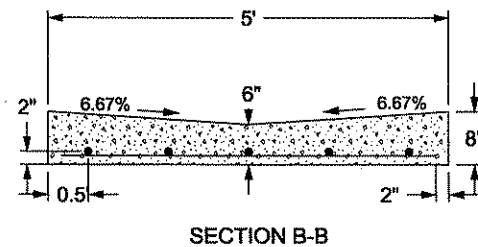
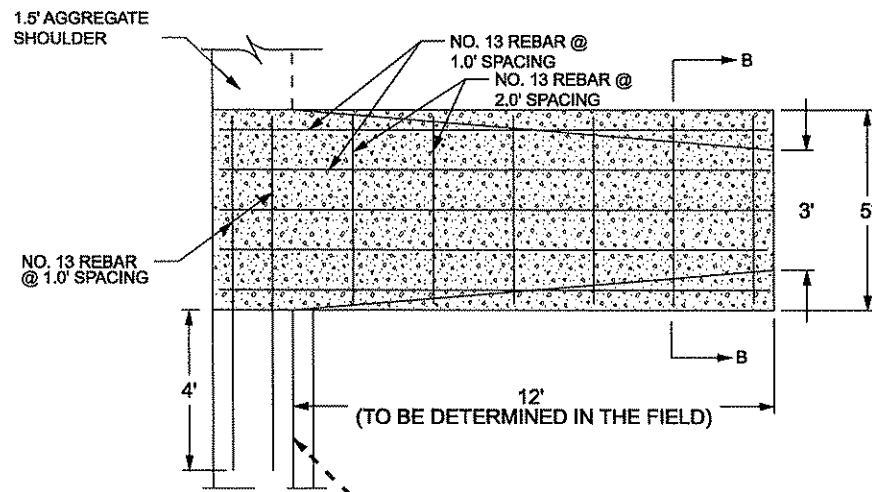

**B4 MODIFIED CURB & GUTTER**

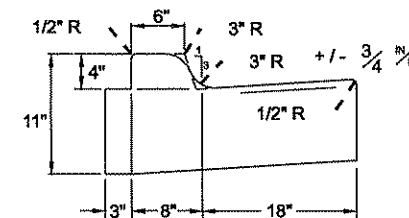

**SAFETY EDGE DETAIL**

NOT TO SCALE

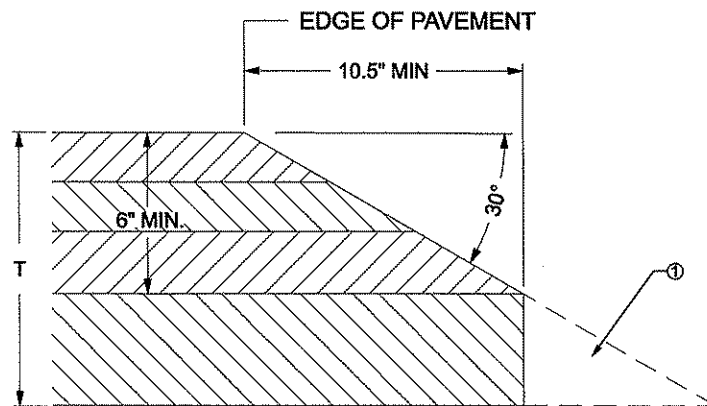

FOR T => 6"

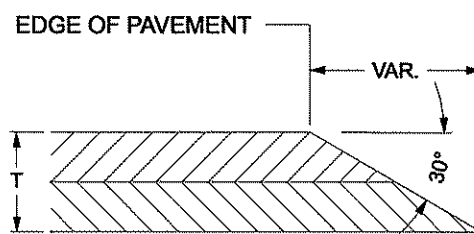

FOR T < 6"

① OPTIONAL DESIGN EXTENDS SAFETY EDGE DEEPER THAN 6" AND WIDER THAN 10.5". SEE PLAN DESIGN DETAILS.

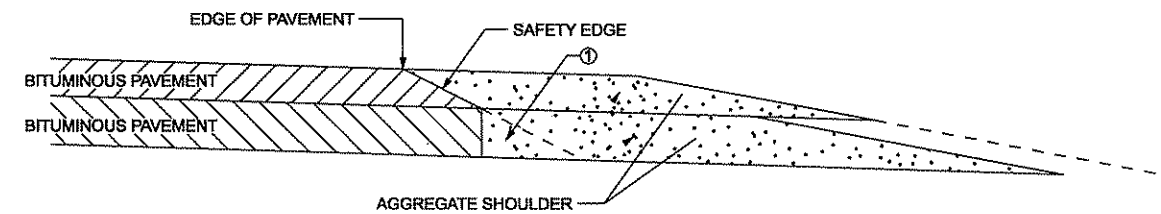

BITUMINOUS PAVEMENT

① OPTIONAL DESIGN EXTENDS SAFETY EDGE DEEPER THAN 6" AND WIDER THAN 10.5". SEE PLAN DESIGN DETAILS.

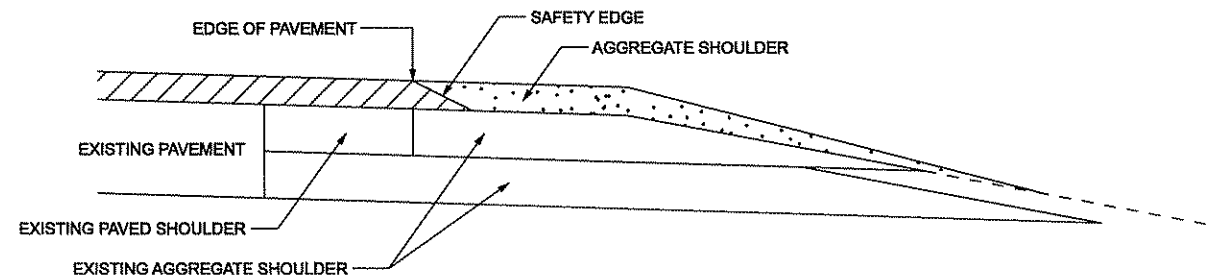

BITUMINOUS OVERLAY

**MEDIAN DETAIL**

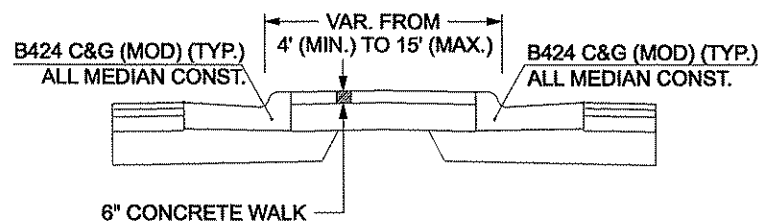

NO	DATE	BY	CKD	APPR	REVISION
NAME: p:\116-65\plan\116-65_MISC_DET.dgn					
06/27/2012 8:34:39 AM					

I HEREBY CERTIFY THAT THIS PLAN WAS PREPARED BY ME OR UNDER MY DIRECT SUPERVISION AND THAT I AM A DULY LICENSED PROFESSIONAL ENGINEER UNDER THE LAWS OF THE STATE OF MINNESOTA.  
 PRINT NAME: Curt Koblarcski  
 SIGNATURE: *Curt Koblarcski*  
 DATE: 6-27-12 LICENSE NO. 24756

DRAWN BY: BAV DATE: 3-23-12  
 DESIGN BY: BAV DATE: 3-23-12  
 CHECKED BY: JEO DATE: 4-10-12

**ANOKA COUNTY**  
**HIGHWAY DEPT.**

S.P. 0208-145 (T.H. 65)  
 S.A.P. 002-716-013  
 S.A.P. 197-020-004

MISCELLANEOUS DETAILS  
 Sheet 21 of 108 Sheets

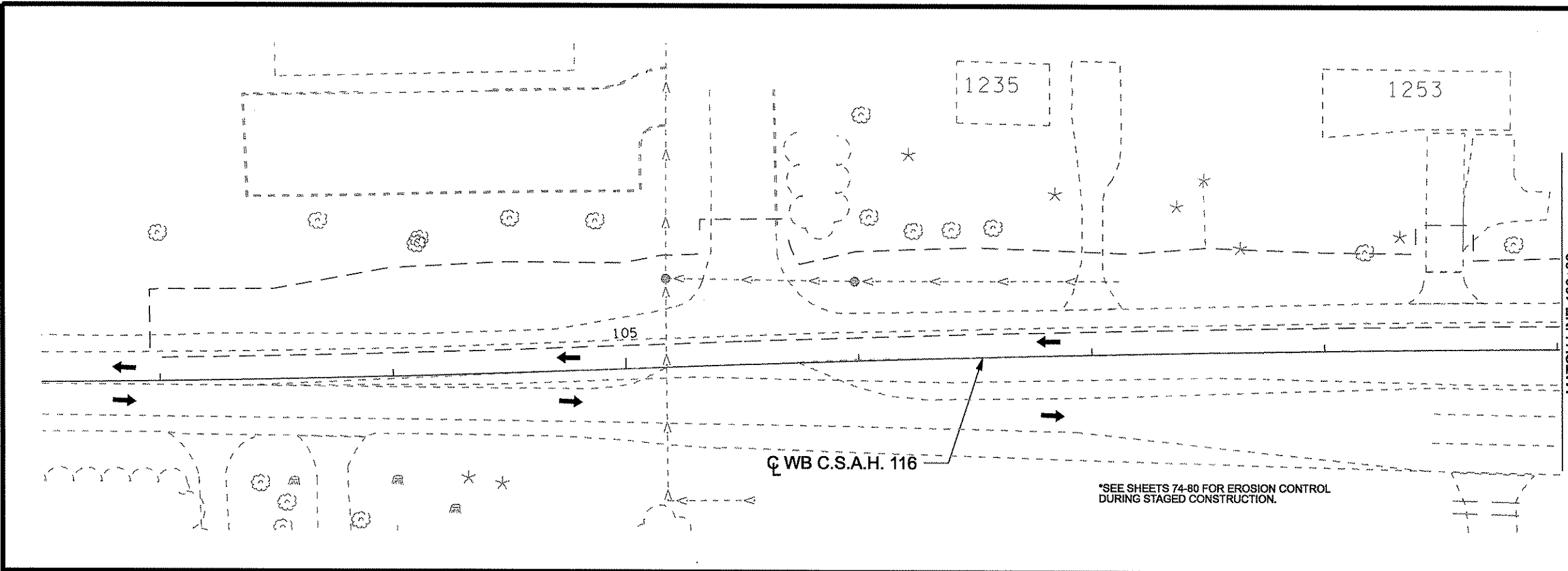

**LEGEND**

- WORK AREA
- WORK AREA TO BE COMPLETED UNDER TRAFFIC
- EXISTING TOPOGRAPHY
- CONSTRUCTION TO BE COMPLETED DURING CURRENT STAGE
- COMPLETED CONSTRUCTION
- TRAFFIC FLOW DIRECTION
- DRAINAGE TO BE COMPLETED DURING CURRENT STAGE
- INPLACE DRAINAGE PIPES

- STAGE 1 TRAFFIC CONTROL NOTES:**
- 1) CSAH 116 AND TH 65 REMAIN OPEN TO ALL TRAFFIC EXCEPT FOR SB TH 65 RIGHT TURN MOVEMENTS ONTO WB CSAH 116.
  - 2) MNDOT FIELD MANUAL LAYOUTS AND FLAGGER SET-UPS TO BE UTILIZED TO COMPLETE PIPE CROSSINGS FROM STRUCTURES 107 & 109 WHILE WB CSAH 116 REMAINS OPEN TO TRAFFIC.
  - 3) CONTRACTOR SHALL MAINTAIN 10 FT MINIMUM LEFT TURN LANE WIDTHS AND 12 FT THRU LANE WIDTHS ON TH 65.
  - 4) CONTRACTOR SHALL PROVIDE 3 FT BUFFER AREA ADJACENT TO PORTABLE PRECAST CONCRETE BARRIER.

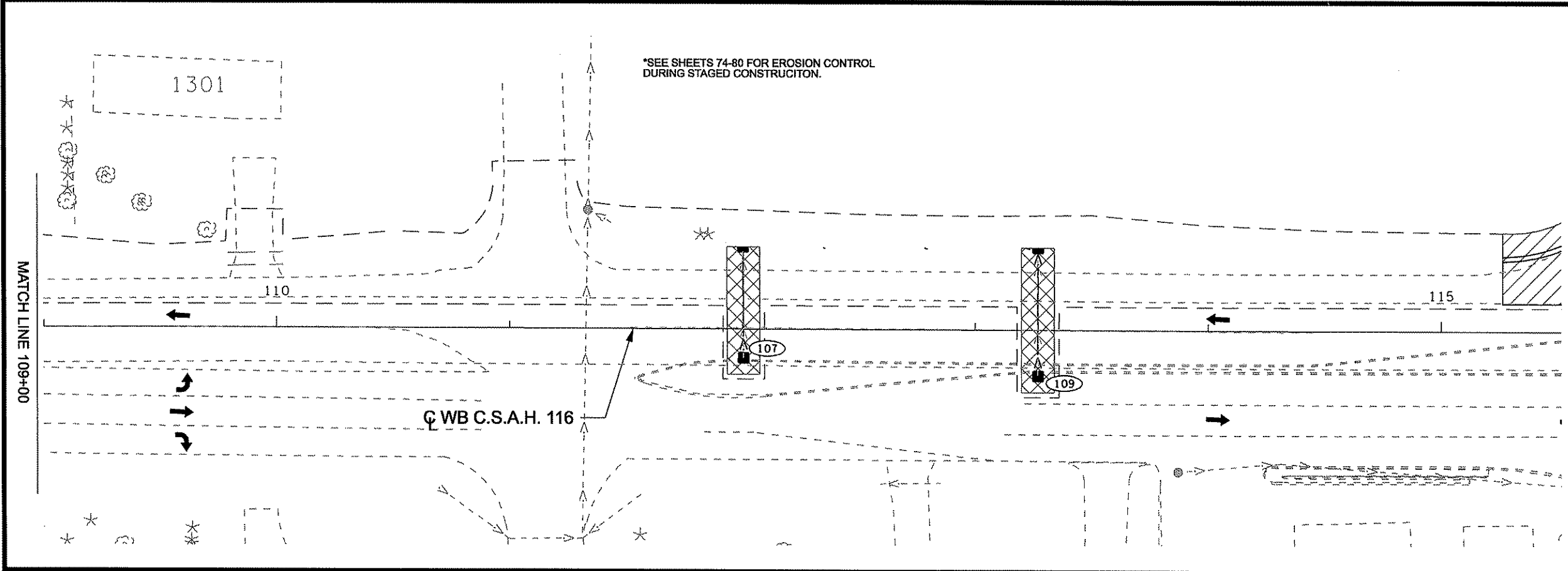

- STAGE 1 CONSTRUCTION NOTES:**
- 1) CLEAR AND GRUB.
  - 2) PIPE CROSSING FROM STRUCTURES 107 & 109 SHALL BE DONE UNDER FLAGGING OPERATIONS. STUB OUT PIPE TO PROPOSED NEW CONSTRUCTION LIMITS.
  - 3) CONSTRUCT SB TH 65 LEFT TURN LANE EXTENSION.
  - 4) CONSTRUCTION NB TH 65 LEFT TURN LANE EXTENSION AND ADDITIONAL NB TH 65 LEFT TURN LANE.
  - 5) BEGIN TRAFFIC SIGNAL RECONSTRUCTION WORK THAT IS REQUIRED/DOES NOT CONFLICT FOR STAGE 2.
  - 6) COMPLETE UTILITY RELOCATIONS THIS STAGE THAT ARE REQUIRED FOR STAGE 2.
  - 7) EXTEND TH 65 MEDIAN CULVERT.
  - 8) COMPLETE SB TH 65 RIGHT TURN LANE/PORK CHOP ISLAND MODIFICATIONS.

N

SCALE IN FEET

1 OF 6

NO	DATE	BY	CHKD	APPR	REVISION
NAME: p:\116-65\plan\116-65_STG1.dgn					
06/26/2012 11:41:25 AM					

I HEREBY CERTIFY THAT THIS PLAN WAS PREPARED BY ME OR UNDER MY DIRECT SUPERVISION AND THAT I AM A DULY LICENSED PROFESSIONAL ENGINEER UNDER THE LAWS OF THE STATE OF MINNESOTA.

PRINT NAME: Curt Koblarcsik

SIGNATURE: *Curt Koblarcsik*

DATE: 6-27-12 LICENSE NO. 24758

DRAWN BY: BAV DATE: 3-23-12

DESIGN BY: BAV DATE: 3-23-12

CHECKED BY: JEO DATE: 4-10-12









ANOKA COUNTY HIGHWAY DEPT.

S.P. 0208-145 (T.H. 65)  
 S.A.P. 002-716-013  
 S.A.P. 197-020-004

CONSTRUCTION STAGING  
STAGE 1

Sheet 22 of 108 Sheets

**LEGEND**

-  WORK AREA
-  WORK AREA TO BE COMPLETED UNDER TRAFFIC
-  EXISTING TOPOGRAPHY
-  CONSTRUCTION TO BE COMPLETED DURING CURRENT STAGE
-  COMPLETED CONSTRUCTION
-  TRAFFIC FLOW DIRECTION
-  DRAINAGE TO BE COMPLETED DURING CURRENT STAGE
-  INPLACE DRAINAGE PIPES

- STAGE 1 TRAFFIC CONTROL NOTES:**
- 1) CSAH 116 AND TH 65 REMAIN OPEN TO ALL TRAFFIC EXCEPT FOR SB TH 65 RIGHT TURN MOVEMENTS ONTO WB CSAH 116.
  - 2) MNDOT FIELD MANUAL LAYOUTS AND FLAGGER SET-UPS TO BE UTILIZED TO COMPLETE PIPE CROSSINGS FROM STRUCTURES 107 & 109 WHILE WB CSAH 116 REMAINS OPEN TO TRAFFIC.
  - 3) CONTRACTOR SHALL MAINTAIN 10 FT MINIMUM LEFT TURN LANE WIDTHS AND 12 FT THRU LANE WIDTHS ON TH 65.
  - 4) CONTRACTOR SHALL PROVIDE 3 FT BUFFER AREA ADJACENT TO PORTABLE PRECAST CONCRETE BARRIER.

- STAGE 1 CONSTRUCTION NOTES:**
- 1) CLEAR AND GRUB.
  - 2) PIPE CROSSING FROM STRUCTURES 107 & 109 SHALL BE DONE UNDER FLAGGING OPERATIONS. STUB OUT PIPE TO PROPOSED NEW CONSTRUCTION LIMITS.
  - 3) CONSTRUCT SB TH 65 LEFT TURN LANE EXTENSION.
  - 4) CONSTRUCTION NB TH 65 LEFT TURN LANE EXTENSION AND ADDITIONAL NB TH 65 LEFT TURN LANE.
  - 5) BEGIN TRAFFIC SIGNAL RECONSTRUCTION WORK THAT IS REQUIRED/DOES NOT CONFLICT FOR STAGE 2.
  - 6) COMPLETE UTILITY RELOCATIONS THIS STAGE THAT ARE REQUIRED FOR STAGE 2.
  - 7) EXTEND TH 65 MEDIAN CULVERT.
  - 8) COMPLETE SB TH 65 RIGHT TURN LANE/PORK CHOP ISLAND MODIFICATIONS.
  - 9) REMOVE SILT FENCE, PLACE TOPSOIL, AND STABILIZE.

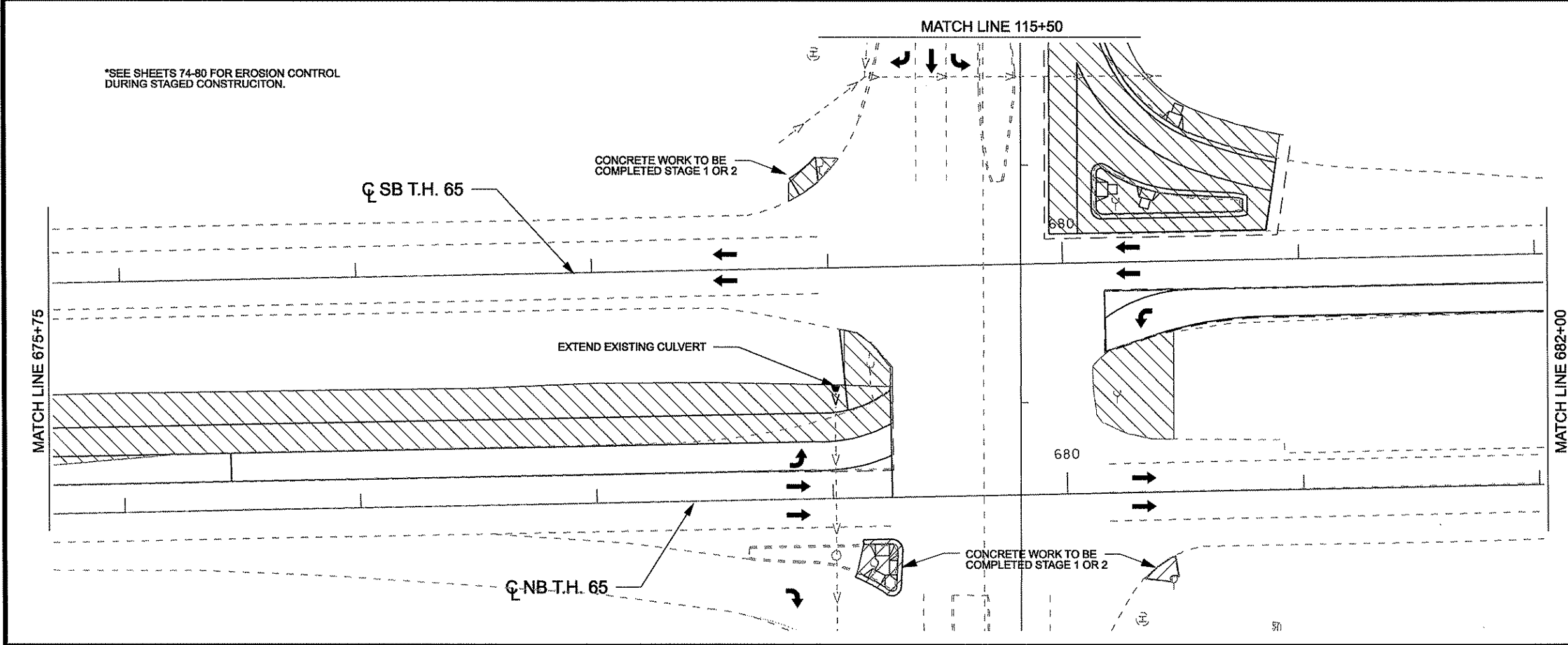
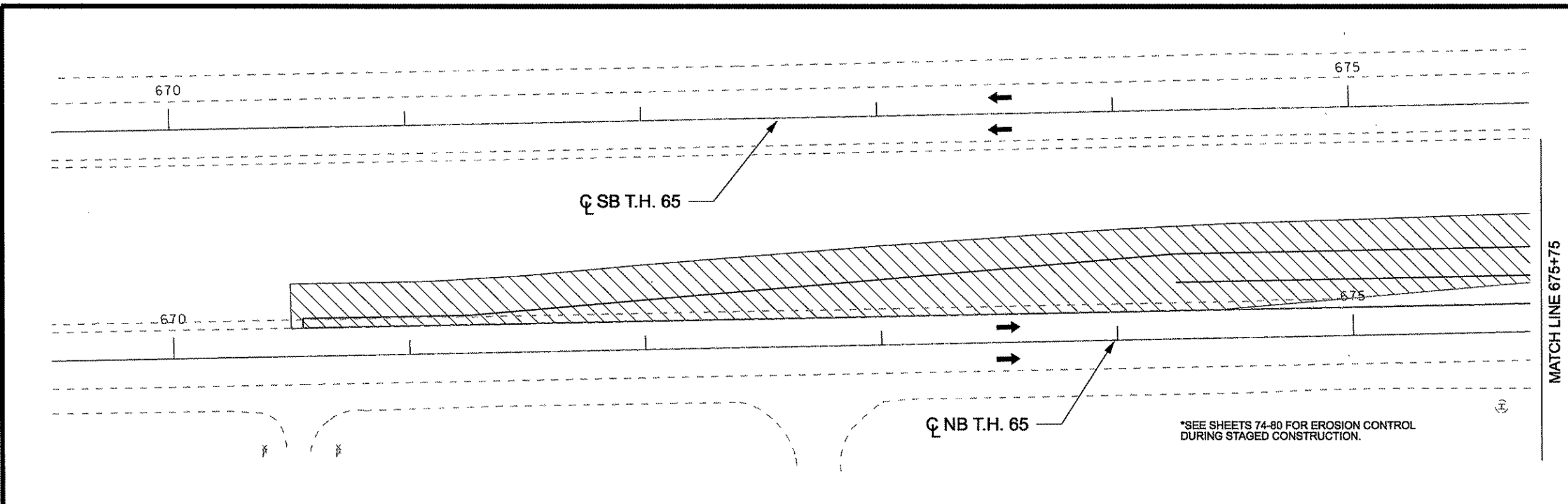
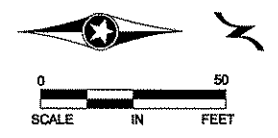

NO	DATE	BY	CKD	APPR	REVISION
NAME: p:\116-69\plan\116-65_STG2.dgn					
DATE: 06/26/2012 11:41:29 AM					

I HEREBY CERTIFY THAT THIS PLAN WAS PREPARED BY ME OR UNDER MY DIRECT SUPERVISION AND THAT I AM A DULY LICENSED PROFESSIONAL ENGINEER UNDER THE LAWS OF THE STATE OF MINNESOTA.

PRINT NAME: Curt Kobilarcsik  
 SIGNATURE: *Curt Kobilarcsik*  
 DATE: 6-27-12 LICENSE NO. 24756

DRAWN BY: BAV DATE: 3-23-12  
 DESIGN BY: BAV DATE: 3-23-12  
 CHECKED BY: JEO DATE: 4-10-12



S.P. 0208-145 (T.H. 65)  
 S.A.P. 002-716-013  
 S.A.P. 197-020-004

CONSTRUCTION STAGING  
 STAGE 1

Sheet 23 of 108 Sheets

MATCH LINE 682+00

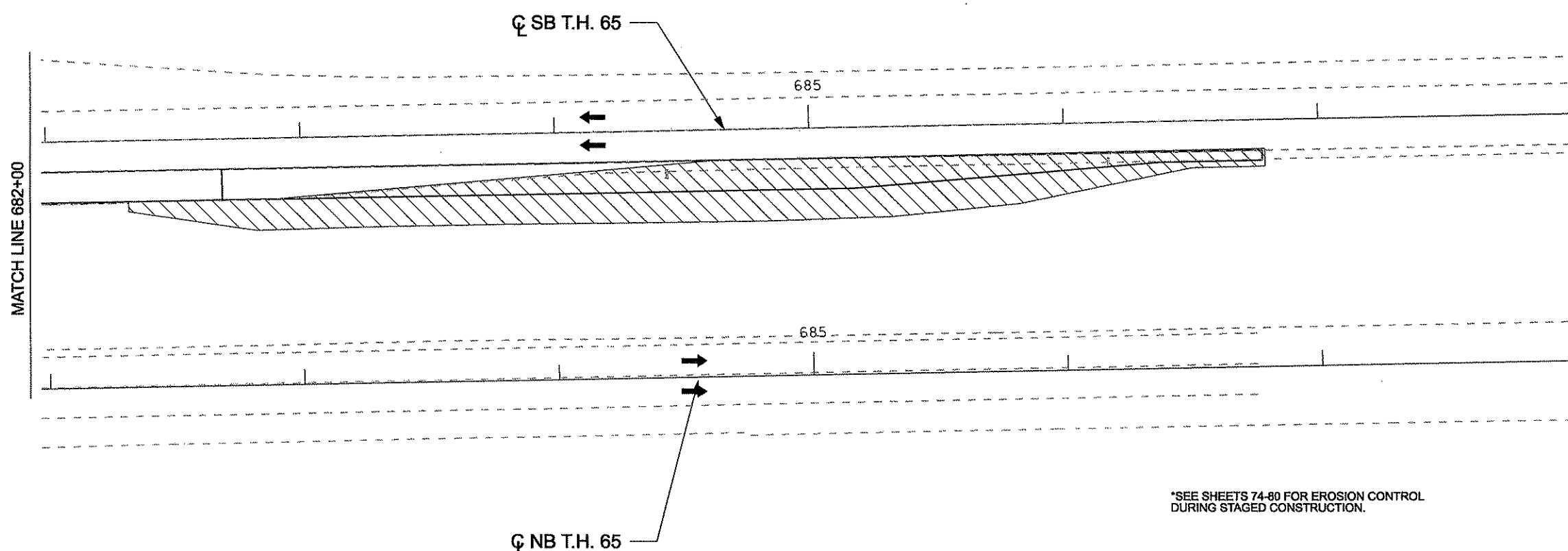

**LEGEND**

- WORK AREA
- WORK AREA TO BE COMPLETED UNDER TRAFFIC
- EXISTING TOPOGRAPHY
- CONSTRUCTION TO BE COMPLETED DURING CURRENT STAGE
- COMPLETED CONSTRUCTION
- TRAFFIC FLOW DIRECTION
- DRAINAGE TO BE COMPLETED DURING CURRENT STAGE
- INPLACE DRAINAGE PIPES

- STAGE 1 TRAFFIC CONTROL NOTES:**
- 1) CSAH 116 AND TH 65 REMAIN OPEN TO ALL TRAFFIC EXCEPT FOR SB TH 65 RIGHT TURN MOVEMENTS ONTO WB CSAH 116.
  - 2) MNDOT FIELD MANUAL LAYOUTS AND FLAGGER SET-UPS TO BE UTILIZED TO COMPLETE PIPE CROSSINGS FROM STRUCTURES 107 & 109 WHILE WB CSAH 116 REMAINS OPEN TO TRAFFIC.
  - 3) CONTRACTOR SHALL MAINTAIN 10 FT MINIMUM LEFT TURN LANE WIDTHS AND 12 FT THRU LANE WIDTHS ON TH 65.
  - 4) CONTRACTOR SHALL PROVIDE 3 FT BUFFER AREA ADJACENT TO PORTABLE PRECAST CONCRETE BARRIER.

- STAGE 1 CONSTRUCTION NOTES:**
- 1) CLEAR AND GRUB.
  - 2) PIPE CROSSING FROM STRUCTURES 107 & 109 SHALL BE DONE UNDER FLAGGING OPERATIONS. STUB OUT PIPE TO PROPOSED NEW CONSTRUCTION LIMITS.
  - 3) CONSTRUCT SB TH 65 LEFT TURN LANE EXTENSION.
  - 4) CONSTRUCTION NB TH 65 LEFT TURN LANE EXTENSION AND ADDITIONAL NB TH 65 LEFT TURN LANE.
  - 5) BEGIN TRAFFIC SIGNAL RECONSTRUCTION WORK THAT IS REQUIRED/DOES NOT CONFLICT FOR STAGE 2.
  - 6) COMPLETE UTILITY RELOCATIONS THIS STAGE THAT ARE REQUIRED FOR STAGE 2.
  - 7) EXTEND TH 65 MEDIAN CULVERT.
  - 8) COMPLETE SB TH 65 RIGHT TURN LANE/PORK CHOP ISLAND MODIFICATIONS.
  - 9) REMOVE SILT FENCE, PLACE TOPSOIL AND STABILIZE (PERMANENTLY)

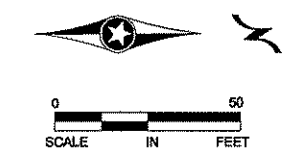

3 OF 6

NO	DATE	BY	CKD	APPR	REVISION
NAME: p:\116-65\plan\116-65_STG3.dgn					

I HEREBY CERTIFY THAT THIS PLAN WAS PREPARED BY ME OR UNDER MY DIRECT SUPERVISION AND THAT I AM A DULY LICENSED PROFESSIONAL ENGINEER UNDER THE LAWS OF THE STATE OF MINNESOTA.

PRINT NAME: Curt Kobilarscik

SIGNATURE:

DATE: 6-27-12 LICENSE NO. 24756

DRAWN BY BAV DATE 3-23-12

DESIGN BY BAV DATE 3-23-12

CHECKED BY JEO DATE 4-10-12

**ANOKA COUNTY**  
**HIGHWAY DEPT.**









S.P. 0208-145 (T.H. 65)  
S.A.P. 002-716-013  
S.A.P. 197-020-004

**CONSTRUCTION STAGING**  
**STAGE 1**

Sheet 24 of 108 Sheets



**LEGEND**

-  WORK AREA
-  WORK AREA TO BE COMPLETED UNDER TRAFFIC
-  EXISTING TOPOGRAPHY
-  CONSTRUCTION TO BE COMPLETED DURING CURRENT STAGE
-  COMPLETED CONSTRUCTION
-  TRAFFIC FLOW DIRECTION
-  DRAINAGE TO BE COMPLETED DURING CURRENT STAGE
-  INPLACE DRAINAGE PIPES

- STAGE 2 CONSTRUCTION NOTES:**
- 1) COMPLETE CLEAR AND GRUB. INSTALL SILT FENCE.
  - 2) REMOVE EXISTING WB CSAH 116 RT TURN LANE/SHOULDER.
  - 3) CONSTRUCT STORM SEWER. INSTALL TEMPORARY BMP'S.
  - 4) CONTINUE TRAFFIC SIGNAL RECONSTRUCTION WORK.
  - 5) COMPLETE ANY REMAINING UTILITY RELOCATION WORK.

- 6) COMPLETE FINAL WEAR PAVING AND FINAL SIGNING/STRIPING ON CSAH 116.
- 7) COMPLETE TH 65 MILL AND OVERLAY AND FINAL SIGNING/STRIPING.

- STAGE 2 TRAFFIC CONTROL NOTES:**
- 1) CSAH 116 AND TH 65 TRAFFIC TO REMAIN OPEN TO ALL TRAFFIC.
  - 2) PAVEMENT MARKINGS IN ALL TRANSITION AREAS SHALL HAVE TEMPORARY RAISED PAVEMENT MARKERS AT 10 FT INTERVALS.
  - 3) EXISTING STRIPING WHICH CONFLICTS WITH TEMPORARY PAVEMENT MARKINGS SHALL BE REMOVED (WATER BLASTING REQUIRED ON ALL AREAS OF FINAL WEAR).
  - 4) CONTRACTOR TO MAINTAIN 12 FT MINIMUM LANE WIDTHS ON CSAH 116.
  - 5) CONTRACTOR SHALL PROVIDE 3 FT BUFFER AREA ADJACENT TO PORTABLE PRECAST CONCRETE BARRIER.
  - 6) ACCESS SHALL BE MAINTAINED TO ALL DRIVEWAYS AND STREETS WITHIN THE PROJECT LIMITS DURING CONSTRUCTION.
  - 7) MILL AND OVERLAY WORK ON TH 65 SHALL BE COMPLETED UNDER TRAFFIC UTILIZING THE APPROPRIATE MNDOT FIELD MANUAL LAYOUTS.
  - 8) FINAL WEAR PAVING ON CSAH 116 SHALL BE COMPLETED UTILIZING THE APPROPRIATE MNDOT FIELD MANUAL LAYOUTS.

N

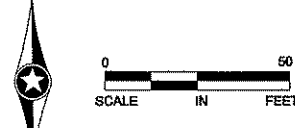

SCALE IN FEET  
0 50

4 OF 6

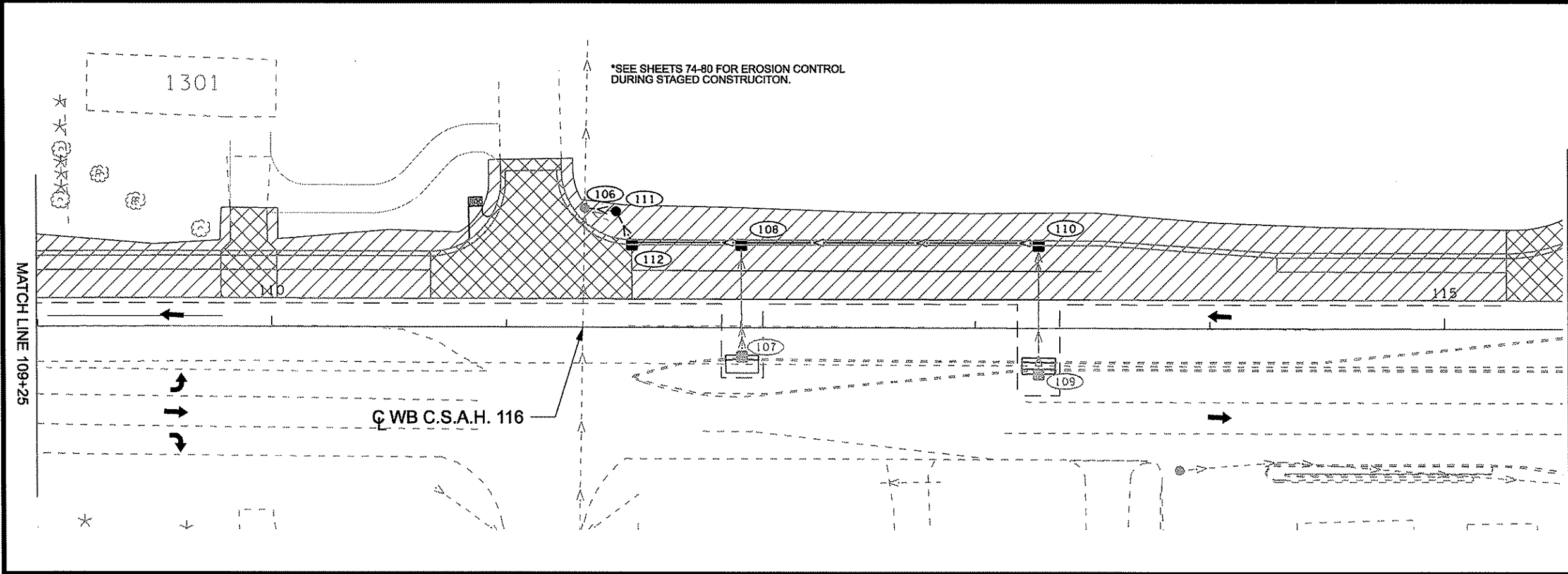
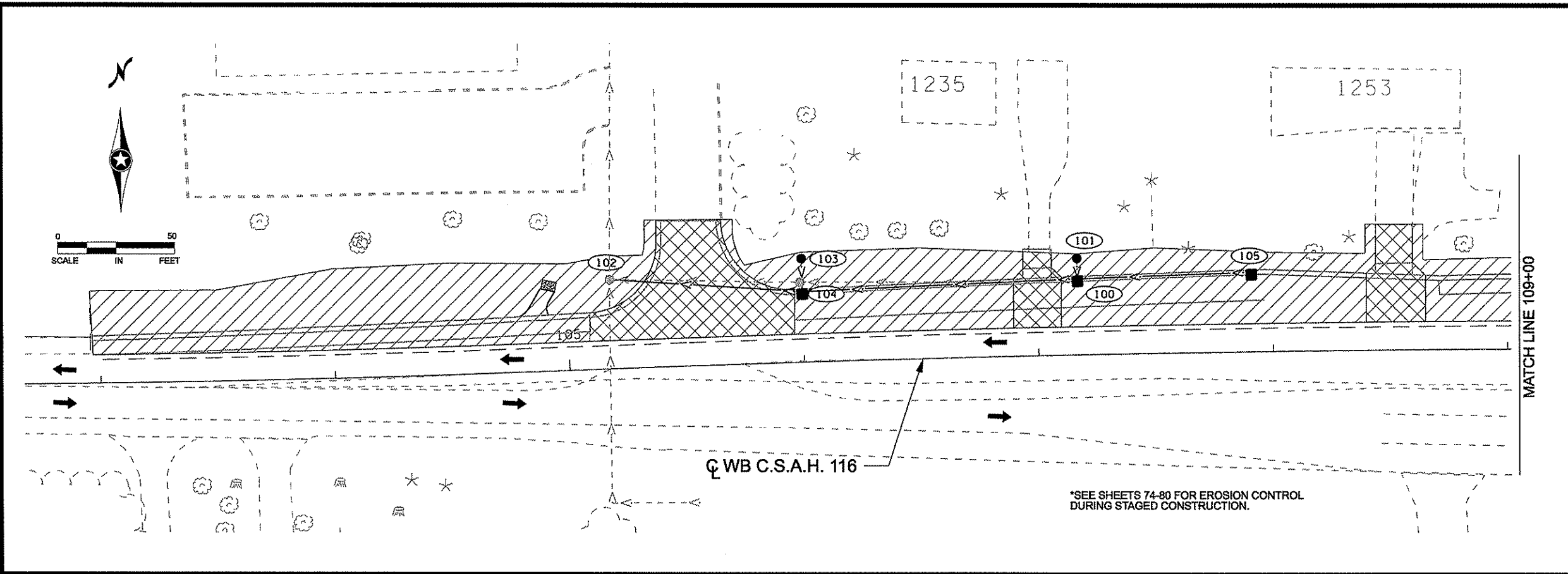

NO	DATE	BY	CHKD	APPR	REVISION
NAME: p:\116-65\plan\116-65_STG4.dgn					

I HEREBY CERTIFY THAT THIS PLAN WAS PREPARED BY ME OR UNDER MY DIRECT SUPERVISION AND THAT I AM A DULY LICENSED PROFESSIONAL ENGINEER UNDER THE LAWS OF THE STATE OF MINNESOTA.

PRINT NAME: Curt Kobjarsnik  
 SIGNATURE: *Curt Kobjarsnik*  
 DATE: 6-27-12 LICENSE NO. 24786

DRAWN BY: BAV DATE: 3-23-12  
 DESIGN BY: BAV DATE: 3-23-12  
 CHECKED BY: JEO DATE: 4-10-12

**ANOKA COUNTY**  
**HIGHWAY DEPT.**



S.P. 0208-145 (T.H. 65)  
 S.A.P. 002-716-013  
 S.A.P. 197-020-004

**CONSTRUCTION STAGING**  
**STAGE 2**

Sheet 25 of 108 Sheets

LEGEND	
	WORK AREA
	WORK AREA TO BE COMPLETED UNDER TRAFFIC
	EXISTING TOPOGRAPHY
	CONSTRUCTION TO BE COMPLETED DURING CURRENT STAGE
	COMPLETED CONSTRUCTION
	TRAFFIC FLOW DIRECTION
	DRAINAGE TO BE COMPLETED DURING CURRENT STAGE
	INPLACE DRAINAGE PIPES

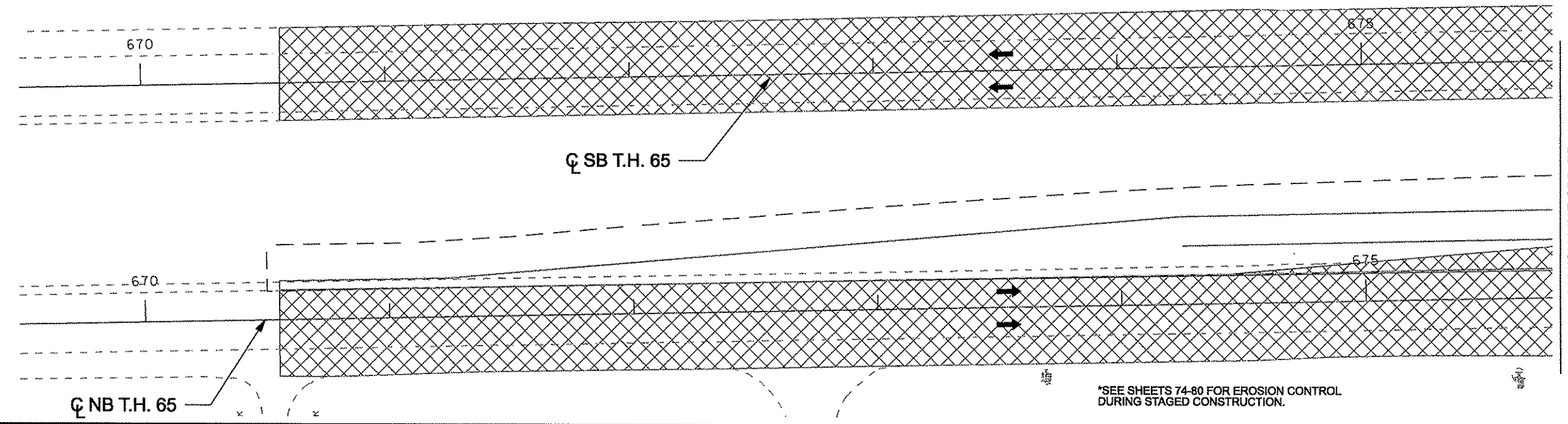

\*SEE SHEETS 74-80 FOR EROSION CONTROL DURING STAGED CONSTRUCTION.

- STAGE 2 CONSTRUCTION NOTES:
- 1) COMPLETE CLEAR AND GRUB.
  - 2) REMOVE EXISTING WB CSAH 116 RT TURN LANE/SHOULDER.
  - 3) CONSTRUCT STORM SEWER.
  - 4) CONTINUE TRAFFIC SIGNAL RECONSTRUCTION WORK.
  - 5) COMPLETE ANY REMAINING UTILITY RELOCATION WORK.
  - 6) COMPLETE FINAL WEAR PAVING AND FINAL SIGNING/STRIPING ON CSAH 116.
  - 7) COMPLETE TH 65 MILL AND OVERLAY AND FINAL SIGNING/STRIPING.

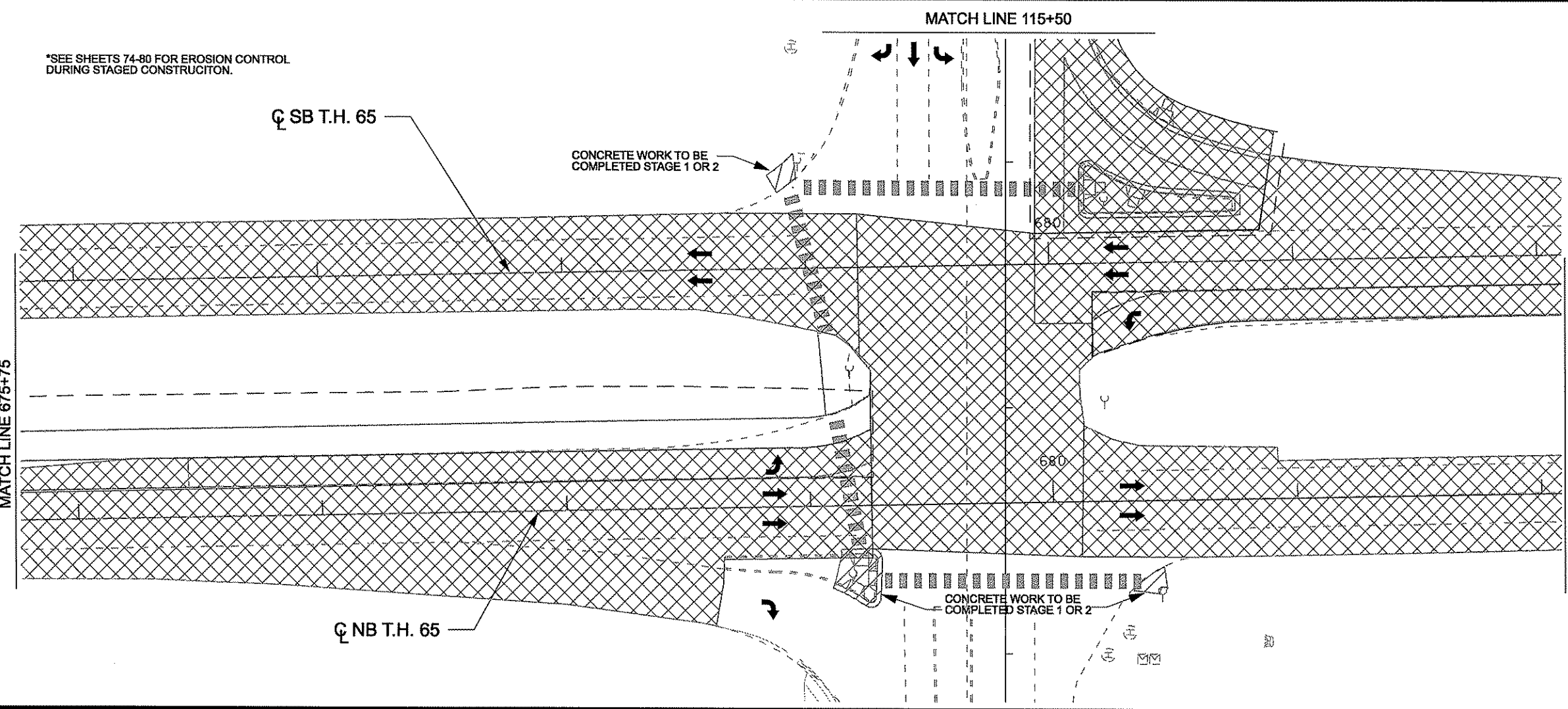

\*SEE SHEETS 74-80 FOR EROSION CONTROL DURING STAGED CONSTRUCTION.

- STAGE 2 TRAFFIC CONTROL NOTES:
- 1) CSAH 116 AND TH 65 TRAFFIC TO REMAIN OPEN TO ALL TRAFFIC.
  - 2) PAVEMENT MARKINGS IN ALL TRANSITION AREAS SHALL HAVE TEMPORARY RAISED PAVEMENT MARKERS AT 10 FT INTERVALS.
  - 3) EXISTING STRIPING WHICH CONFLICTS WITH TEMPORARY PAVEMENT MARKINGS SHALL BE REMOVED (WATER BLASTING REQUIRED ON ALL AREAS OF FINAL WEAR).
  - 4) CONTRACTOR TO MAINTAIN 12 FT MINIMUM LANE WIDTHS ON CSAH 116.
  - 5) CONTRACTOR SHALL PROVIDE 3 FT BUFFER AREA ADJACENT TO PORTABLE PRECAST CONCRETE BARRIER.
  - 6) ACCESS SHALL BE MAINTAINED TO ALL DRIVEWAYS AND STREETS WITHIN THE PROJECT LIMITS DURING CONSTRUCTION.
  - 7) MILL AND OVERLAY WORK ON TH 65 SHALL BE COMPLETED UNDER TRAFFIC UTILIZING THE APPROPRIATE MNDOT FIELD MANUAL LAYOUTS.
  - 8) FINAL WEAR PAVING ON CSAH 116 SHALL BE COMPLETED UTILIZING THE APPROPRIATE MNDOT FIELD MANUAL LAYOUTS.

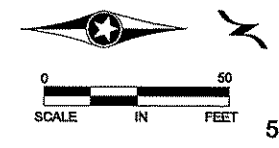

NO	DATE	BY	CHKD	APPR	REVISION
NAME: p:\116-65\plan\116-65_STG5.dgn					
DATE: 06/26/2012 11:41:40 AM					

I HEREBY CERTIFY THAT THIS PLAN WAS PREPARED BY ME OR UNDER MY DIRECT SUPERVISION AND THAT I AM A DULY LICENSED PROFESSIONAL ENGINEER UNDER THE LAWS OF THE STATE OF MINNESOTA.

PRINT NAME: Curt Kobilarcik

SIGNATURE: [Signature]

DATE: 6-27-12 LICENSE NO. 24758

DRAWN BY: BAV DATE: 3-23-12

DESIGN BY: BAV DATE: 3-23-12

CHECKED BY: JEO DATE: 4-10-12

ANOKA COUNTY HIGHWAY DEPT.

S.P. 0208-145 (T.H. 65)  
 S.A.P. 002-716-013  
 S.A.P. 197-020-004

MATCH LINE 682+00

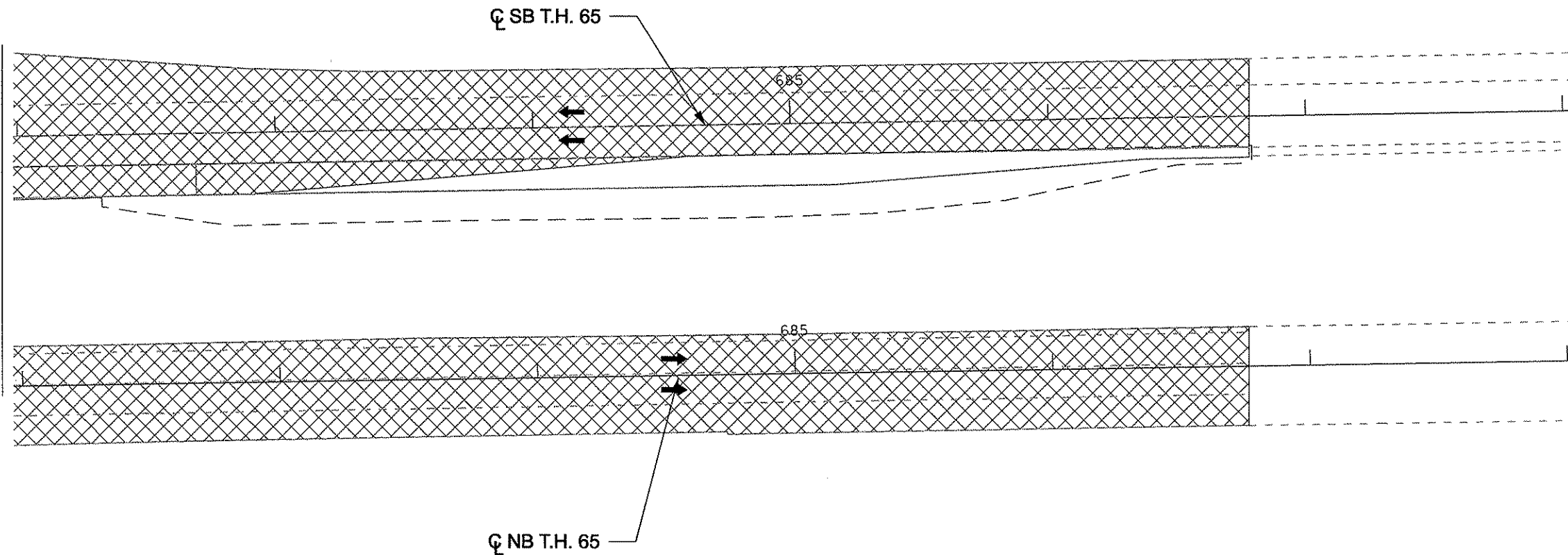

LEGEND	
	WORK AREA
	WORK AREA TO BE COMPLETED UNDER TRAFFIC
	EXISTING TOPOGRAPHY
	CONSTRUCTION TO BE COMPLETED DURING CURRENT STAGE
	COMPLETED CONSTRUCTION
	TRAFFIC FLOW DIRECTION
	DRAINAGE TO BE COMPLETED DURING CURRENT STAGE
	INPLACE DRAINAGE PIPES

- STAGE 2 CONSTRUCTION NOTES:
- 1) COMPLETE CLEAR AND GRUB.
  - 2) REMOVE EXISTING WB CSAH 116 RT TURN LANE/SHOULDER.
  - 3) CONSTRUCT STORM SEWER.
  - 4) CONTINUE TRAFFIC SIGNAL RECONSTRUCTION WORK.
  - 5) COMPLETE ANY REMAINING UTILITY RELOCATION WORK.
  - 6) COMPLETE FINAL WEAR PAVING AND FINAL SIGNING/STRIPING ON CSAH 116.
  - 7) COMPLETE TH 65 MILL AND OVERLAY AND FINAL SIGNING/STRIPING.

- STAGE 2 TRAFFIC CONTROL NOTES:
- 1) CSAH 116 AND TH 65 TRAFFIC TO REMAIN OPEN TO ALL TRAFFIC.
  - 2) PAVEMENT MARKINGS IN ALL TRANSITION AREAS SHALL HAVE TEMPORARY RAISED PAVEMENT MARKERS AT 10 FT INTERVALS.
  - 3) EXISTING STRIPING WHICH CONFLICTS WITH TEMPORARY PAVEMENT MARKINGS SHALL BE REMOVED (WATER BLASTING REQUIRED ON ALL AREAS OF FINAL WEAR).
  - 4) CONTRACTOR TO MAINTAIN 12 FT MINIMUM LANE WIDTHS ON CSAH 116.
  - 5) CONTRACTOR SHALL PROVIDE 3 FT BUFFER AREA ADJACENT TO PORTABLE PRECAST CONCRETE BARRIER.
  - 6) ACCESS SHALL BE MAINTAINED TO ALL DRIVEWAYS AND STREETS WITHIN THE PROJECT LIMITS DURING CONSTRUCTION.
  - 7) MILL AND OVERLAY WORK ON TH 65 SHALL BE COMPLETED UNDER TRAFFIC UTILIZING THE APPROPRIATE MNDOT FIELD MANUAL LAYOUTS.
  - 8) FINAL WEAR PAVING ON CSAH 116 SHALL BE COMPLETED UTILIZING THE APPROPRIATE MNDOT FIELD MANUAL LAYOUTS.

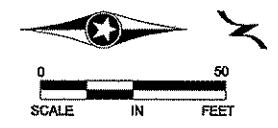

NO	DATE	BY	CHKD	APPR	REVISION
NAME: p:\116-65\plan\116-65_STG8.dgn					
08/28/2012 11:41:44 AM					

I HEREBY CERTIFY THAT THIS PLAN WAS PREPARED BY ME OR UNDER MY DIRECT SUPERVISION AND THAT I AM A DULY LICENSED PROFESSIONAL ENGINEER UNDER THE LAWS OF THE STATE OF MINNESOTA.  
 PRINT NAME: Curt Koblarscik  
 SIGNATURE: [Signature]  
 DATE: 6-27-12 LICENSE NO. 24756

DRAWN BY BAV DATE 3-23-12  
 DESIGN BY BAV DATE 3-23-12  
 CHECKED BY JEO DATE 4-10-12

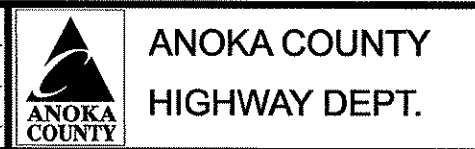

S.P. 0208-145 (T.H. 65)  
 S.A.P. 002-716-013  
 S.A.P. 197-020-004

CONSTRUCTION STAGING  
 STAGE 2  
 Sheet 27 of 108 Sheets

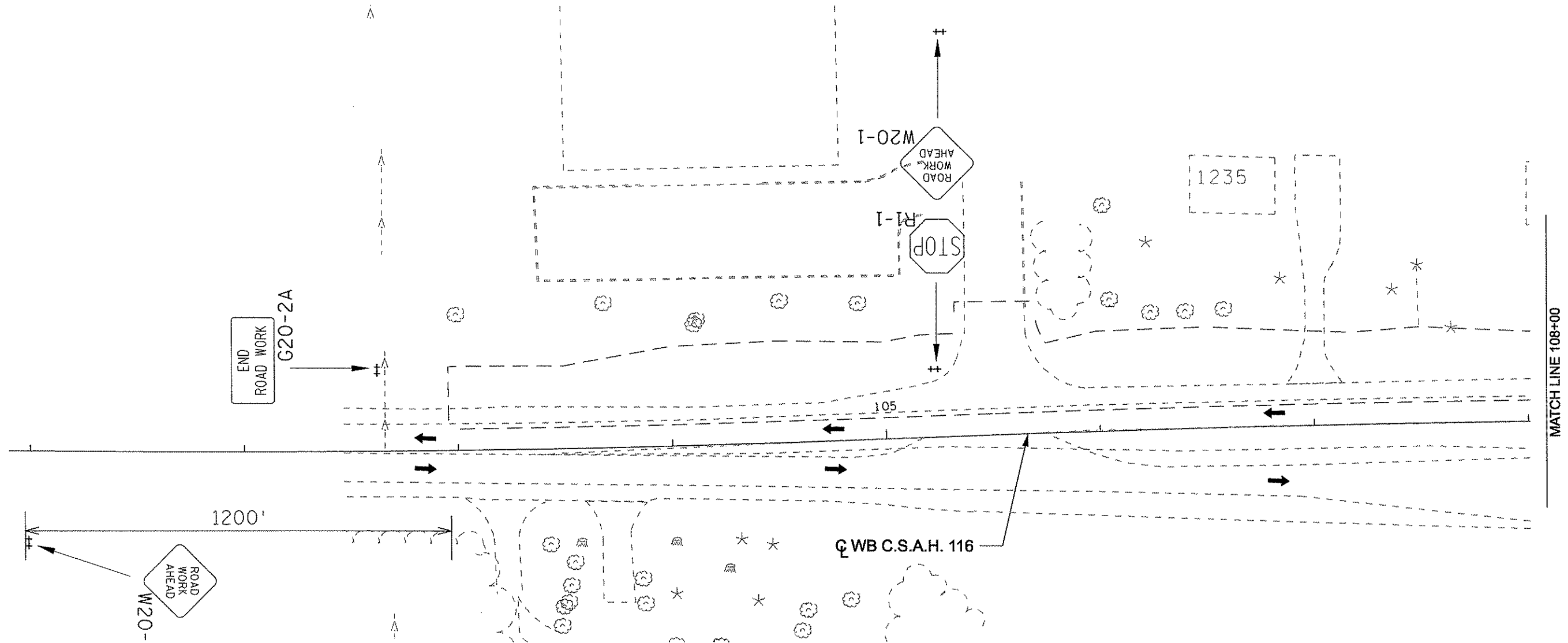

**STAGE 1 TRAFFIC CONTROL NOTES:**

- 1) CSAH 116 AND TH 65 REMAIN OPEN TO ALL TRAFFIC EXCEPT FOR SB TH 65 RIGHT TURN MOVEMENTS ONTO WB CSAH 116.
- 2) MNDOT FIELD MANUAL LAYOUTS AND FLAGGER SET-UPS TO BE UTILIZED TO COMPLETE PIPE CROSSINGS FROM STRUCTURES 107 & 109 WHILE WB CSAH 116 REMAINS OPEN TO TRAFFIC.
- 3) CONTRACTOR SHALL MAINTAIN 10 FT MINIMUM LEFT TURN LANE WIDTHS AND 12 FT THRU LANE WIDTHS ON TH 65.
- 4) CONTRACTOR SHALL PROVIDE 3 FT BUFFER AREA ADJACENT TO PORTABLE PRECAST CONCRETE BARRIER.

**STAGE 1 CONSTRUCTION NOTES:**

- 1) CLEAR AND GRUB.
- 2) PIPE CROSSING FROM STRUCTURES 107 & 109 SHALL BE DONE UNDER FLAGGING OPERATIONS. STUB OUT PIPE TO PROPOSED NEW CONSTRUCTION LIMITS.
- 3) CONSTRUCT SB TH 65 LEFT TURN LANE EXTENSION.
- 4) CONSTRUCTION NB TH 65 LEFT TURN LANE EXTENSION AND ADDITIONAL NB TH 65 LEFT TURN LANE.
- 5) BEGIN TRAFFIC SIGNAL RECONSTRUCTION WORK THAT IS REQUIRED/DOES NOT CONFLICT FOR STAGE 2.
- 6) COMPLETE UTILITY RELOCATIONS THIS STAGE THAT ARE REQUIRED FOR STAGE 2.
- 7) EXTEND TH 65 MEDIAN CULVERT.
- 8) COMPLETE SB TH 65 RIGHT TURN LANE/PORK CHOP ISLAND MODIFICATIONS.

LEGEND	
	CONSTRUCTION AREA
	CONSTRUCTION UNDER TRAFFIC
	REFLECTORIZED DRUM
	PORTABLE PRECAST CONCRETE BARRIER WITH END TREATMENTS AND REFLECTORIZATION



1	6/22/12	BAV	JEO	CAK	TEXT UPDATED
NO	DATE	BY	CKD	APPR	REVISION
NAME: p:\116-65\plan\116-65_TC1.dgn					06/27/2012 8:34:44 AM

I HEREBY CERTIFY THAT THIS PLAN WAS PREPARED BY ME OR UNDER MY DIRECT SUPERVISION AND THAT I AM A DULY LICENSED PROFESSIONAL ENGINEER UNDER THE LAWS OF THE STATE OF MINNESOTA.

PRINT NAME: Curt Kobilarosik

SIGNATURE:

DATE: 6-27-12 LICENSE NO. 24756

DRAWN BY BAV DATE 3-23-12

DESIGN BY BAV DATE 3-23-12

CHECKED BY JEO DATE 4-10-12

**ANOKA COUNTY**  
**HIGHWAY DEPT.**

S.P. 0208-145 (T.H. 65)  
S.A.P. 002-716-013  
S.A.P. 197-020-004

**TRAFFIC CONTROL**  
**STAGE 1**

Sheet 28 of 108 Sheets

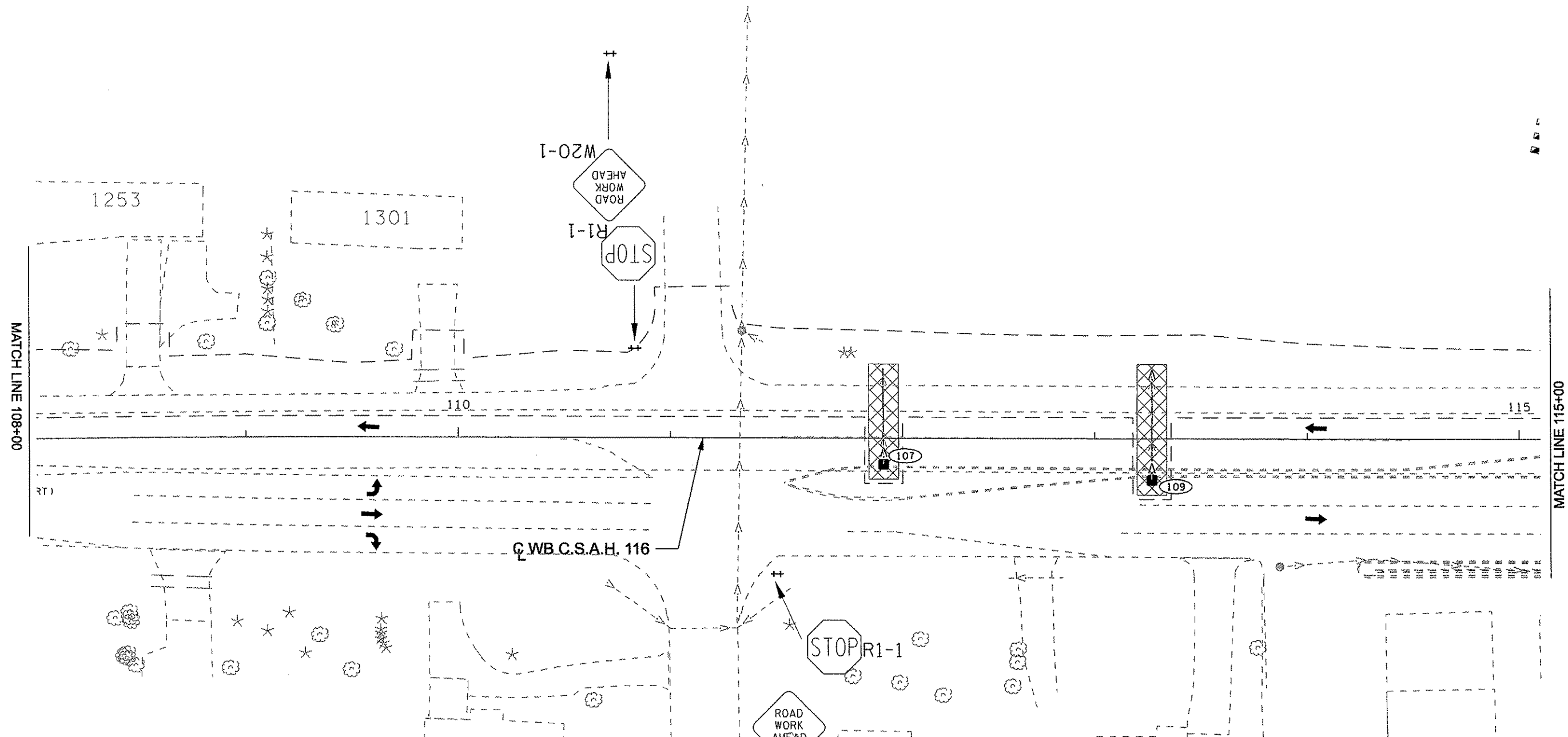

LEGEND	
	CONSTRUCTION AREA
	CONSTRUCTION UNDER TRAFFIC
	REFLECTORIZED DRUM
	PORTABLE PRECAST CONCRETE BARRIER WITH END TREATMENTS AND REFLECTORIZATION

- STAGE 1 TRAFFIC CONTROL NOTES:**
- 1) CSAH 116 AND TH 65 REMAIN OPEN TO ALL TRAFFIC EXCEPT FOR SB TH 65 RIGHT TURN MOVEMENTS ONTO WB CSAH 116.
  - 2) MNDOT FIELD MANUAL LAYOUTS AND FLAGGER SET-UPS TO BE UTILIZED TO COMPLETE PIPE CROSSINGS FROM STRUCTURES 107 & 109 WHILE WB CSAH 116 REMAINS OPEN TO TRAFFIC.
  - 3) CONTRACTOR SHALL MAINTAIN 10 FT MINIMUM LEFT TURN LANE WIDTHS AND 12 FT THRU LANE WIDTHS ON TH 65.
  - 4) CONTRACTOR SHALL PROVIDE 3 FT BUFFER AREA ADJACENT TO PORTABLE PRECAST CONCRETE BARRIER.

- STAGE 1 CONSTRUCTION NOTES:**
- 1) CLEAR AND GRUB.
  - 2) PIPE CROSSING FROM STRUCTURES 107 & 109 SHALL BE DONE UNDER FLAGGING OPERATIONS. STUB OUT PIPE TO PROPOSED NEW CONSTRUCTION LIMITS.
  - 3) CONSTRUCT SB TH 65 LEFT TURN LANE EXTENSION.
  - 4) CONSTRUCTION NB TH 65 LEFT TURN LANE EXTENSION AND ADDITIONAL NB TH 65 LEFT TURN LANE.
  - 5) BEGIN TRAFFIC SIGNAL RECONSTRUCTION WORK THAT IS REQUIRED/DOES NOT CONFLICT FOR STAGE 2.
  - 6) COMPLETE UTILITY RELOCATIONS THIS STAGE THAT ARE REQUIRED FOR STAGE 2.
  - 7) EXTEND TH 65 MEDIAN CULVERT.
  - 8) COMPLETE SB TH 65 RIGHT TURN LANE/PORK CHOP ISLAND MODIFICATIONS.

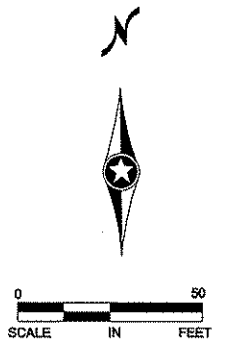

NO	DATE	BY	CHKD	APPR	REVISION
1	6/22/12	BAV	JEO	CAK	TEXT UPDATED

NAME: p:\116-65\plant\116-65\_TC1.dgn      06/27/2012      8:34:46 AM

I HEREBY CERTIFY THAT THIS PLAN WAS PREPARED BY ME OR UNDER MY DIRECT SUPERVISION AND THAT I AM A DULY LICENSED PROFESSIONAL ENGINEER UNDER THE LAWS OF THE STATE OF MINNESOTA.

PRINT NAME: Curt Kobilarcik  
 SIGNATURE:   
 DATE: 6.27.12      LICENSE NO. 24758

DRAWN BY BAV      DATE 3-23-12  
 DESIGN BY BAV      DATE 3-23-12  
 CHECKED BY JEO      DATE 4-10-12



**ANOKA COUNTY  
HIGHWAY DEPT.**

S.P. 0208-145 (T.H. 65)  
 S.A.P. 002-716-013  
 S.A.P. 197-020-004

**TRAFFIC CONTROL  
STAGE 1**

Sheet 29 of 108 Sheets

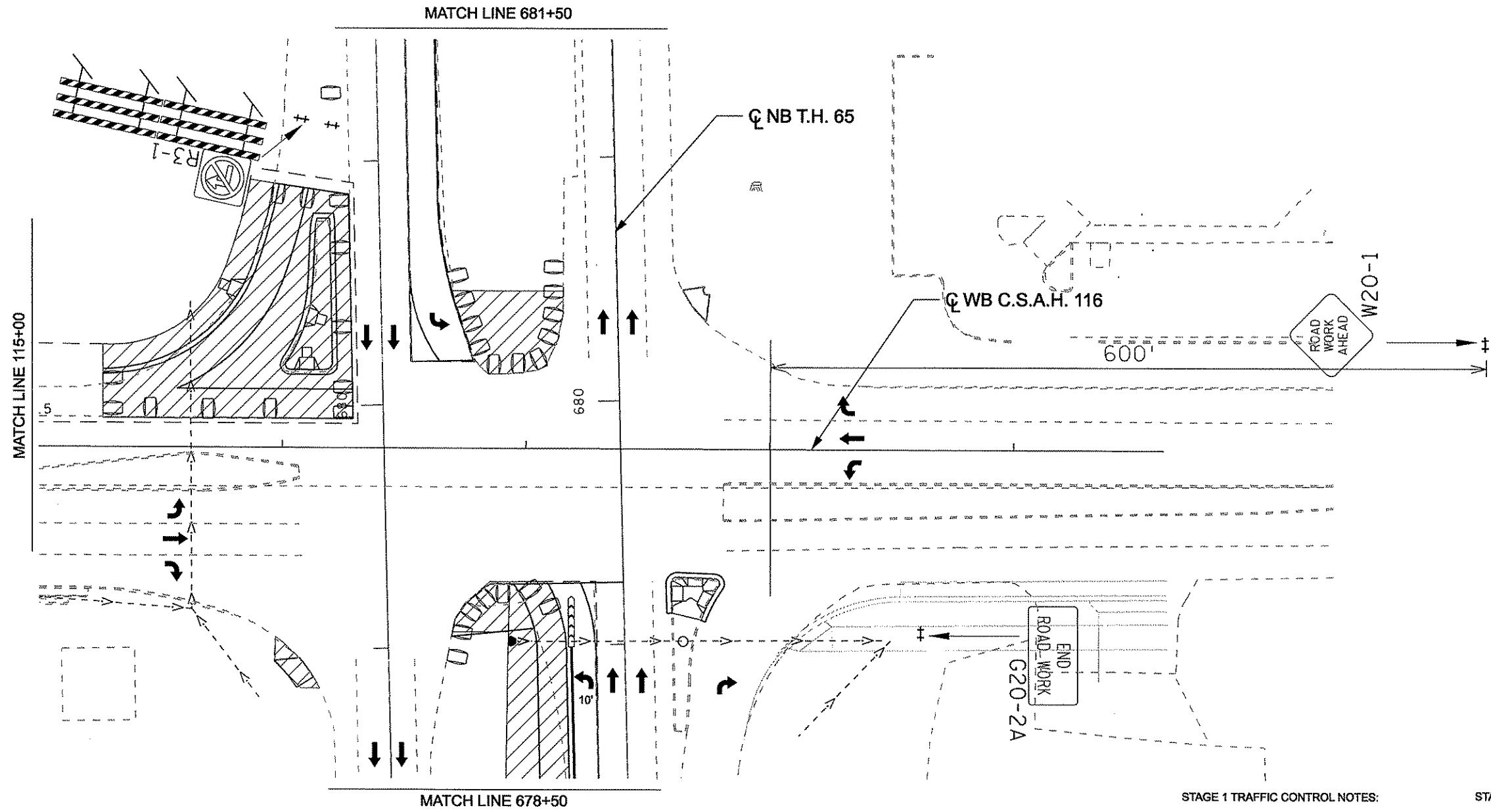

**STAGE 1 TRAFFIC CONTROL NOTES:**

- 1) CSAH 116 AND TH 65 REMAIN OPEN TO ALL TRAFFIC EXCEPT FOR SB TH 65 RIGHT TURN MOVEMENTS ONTO WB CSAH 116.
- 2) MNDOT FIELD MANUAL LAYOUTS AND FLAGGER SET-UPS TO BE UTILIZED TO COMPLETE PIPE CROSSINGS FROM STRUCTURES 107 & 109 WHILE WB CSAH 116 REMAINS OPEN TO TRAFFIC.
- 3) CONTRACTOR SHALL MAINTAIN 10 FT MINIMUM LEFT TURN LANE WIDTHS AND 12 FT THRU LANE WIDTHS ON TH 65.
- 4) CONTRACTOR SHALL PROVIDE 3 FT BUFFER AREA ADJACENT TO PORTABLE PRECAST CONCRETE BARRIER.

**STAGE 1 CONSTRUCTION NOTES:**

- 1) CLEAR AND GRUB.
- 2) PIPE CROSSING FROM STRUCTURES 107 & 109 SHALL BE DONE UNDER FLAGGING OPERATIONS. STUB OUT PIPE TO PROPOSED NEW CONSTRUCTION LIMITS.
- 3) CONSTRUCT SB TH 65 LEFT TURN LANE EXTENSION.
- 4) CONSTRUCTION NB TH 65 LEFT TURN LANE EXTENSION AND ADDITIONAL NB TH 65 LEFT TURN LANE.
- 5) BEGIN TRAFFIC SIGNAL RECONSTRUCTION WORK THAT IS REQUIRED/DOES NOT CONFLICT FOR STAGE 2.
- 6) COMPLETE UTILITY RELOCATIONS THIS STAGE THAT ARE REQUIRED FOR STAGE 2.
- 7) EXTEND TH 65 MEDIAN CULVERT.
- 8) COMPLETE SB TH 65 RIGHT TURN LANE/PORK CHOP ISLAND MODIFICATIONS.

LEGEND	
	CONSTRUCTION AREA
	CONSTRUCTION UNDER TRAFFIC
	REFLECTORIZED DRUM
	PORTABLE PRECAST CONCRETE BARRIER
	WITH END TREATMENTS AND REFELCTORIZATION

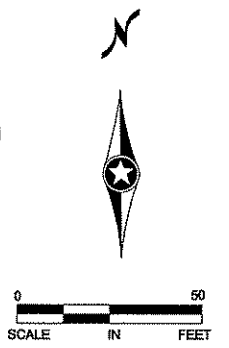

1	6/22/12	BAV	JEO	CAK	TEXT UPDATED
NO	DATE	BY	CHKD	APPR	REVISION
NAME: p:116-85plan116-65_TC1.dgn					
08/27/2012 8:34:48 AM					

I HEREBY CERTIFY THAT THIS PLAN WAS PREPARED BY ME OR UNDER MY DIRECT SUPERVISION AND THAT I AM A DULY LICENSED PROFESSIONAL ENGINEER UNDER THE LAWS OF THE STATE OF MINNESOTA.

PRINT NAME: Curt Koblaroski

SIGNATURE:

DATE: 6-27-12 LICENSE NO. 24756

DRAWN BY BAV DATE 3-23-12

DESIGN BY BAV DATE 3-23-12

CHECKED BY JEO DATE 4-10-12



**ANOKA COUNTY  
HIGHWAY DEPT.**

S.P. 0208-145 (T.H. 65)  
S.A.P. 002-716-013  
S.A.P. 197-020-004

**TRAFFIC CONTROL  
STAGE 1**

Sheet 30 of 108 Sheets

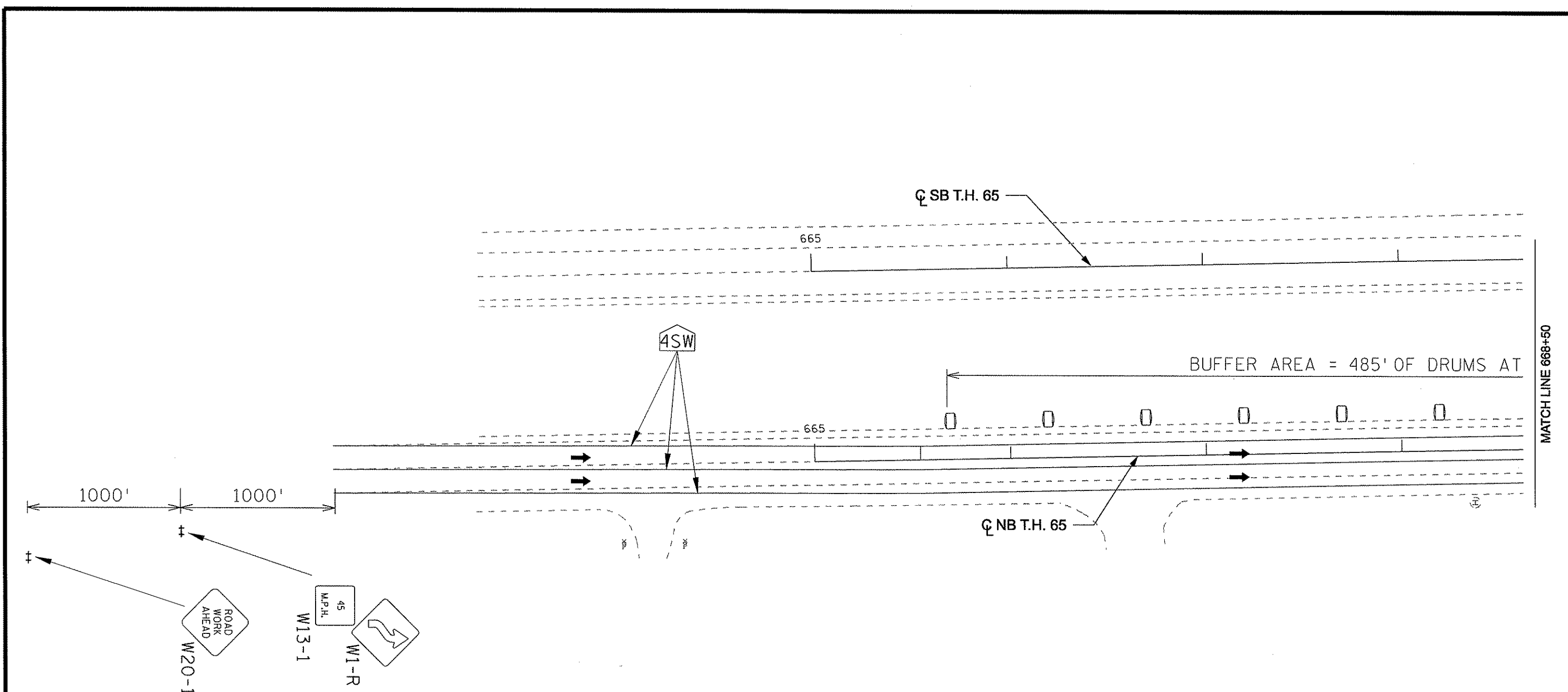

LEGEND	
	CONSTRUCTION AREA
	CONSTRUCTION UNDER TRAFFIC
	REFLECTORIZED DRUM
	PORTABLE PRECAST CONCRETE BARRIER WITH END TREATMENTS AND REFLECTORIZATION

**STAGE 1 TRAFFIC CONTROL NOTES:**

- 1) CSAH 116 AND TH 65 REMAIN OPEN TO ALL TRAFFIC EXCEPT FOR SB TH 65 RIGHT TURN MOVEMENTS ONTO WB CSAH 116.
- 2) MNDOT FIELD MANUAL LAYOUTS AND FLAGGER SET-UPS TO BE UTILIZED TO COMPLETE PIPE CROSSINGS FROM STRUCTURES 107 & 109 WHILE WB CSAH 116 REMAINS OPEN TO TRAFFIC.
- 3) CONTRACTOR SHALL MAINTAIN 10 FT MINIMUM LEFT TURN LANE WIDTHS AND 12 FT THRU LANE WIDTHS ON TH 65.
- 4) CONTRACTOR SHALL PROVIDE 3 FT BUFFER AREA ADJACENT TO PORTABLE PRECAST CONCRETE BARRIER.

**STAGE 1 CONSTRUCTION NOTES:**

- 1) CLEAR AND GRUB.
- 2) PIPE CROSSING FROM STRUCTURES 107 & 109 SHALL BE DONE UNDER FLAGGING OPERATIONS. STUB OUT PIPE TO PROPOSED NEW CONSTRUCTION LIMITS.
- 3) CONSTRUCT SB TH 65 LEFT TURN LANE EXTENSION.
- 4) CONSTRUCTION NB TH 65 LEFT TURN LANE EXTENSION AND ADDITIONAL NB TH 65 LEFT TURN LANE.
- 5) BEGIN TRAFFIC SIGNAL RECONSTRUCTION WORK THAT IS REQUIRED/DOES NOT CONFLICT FOR STAGE 2.
- 6) COMPLETE UTILITY RELOCATIONS THIS STAGE THAT ARE REQUIRED FOR STAGE 2.
- 7) EXTEND TH 65 MEDIAN CULVERT.
- 8) COMPLETE SB TH 65 RIGHT TURN LANE/PORK CHOP ISLAND MODIFICATIONS.

1	6/22/12	BAV	JEO	CAK	TEXT UPDATED
NO	DATE	BY	CHKD	APPR	REVISION
NAME: p:\116-65\plan\116-65_TC2.dgn					06/27/2012 8:34:53 AM

I HEREBY CERTIFY THAT THIS PLAN WAS PREPARED BY ME OR UNDER MY DIRECT SUPERVISION AND THAT I AM A DULY LICENSED PROFESSIONAL ENGINEER UNDER THE LAWS OF THE STATE OF MINNESOTA.  
 PRINT NAME: Curt Kopilarscik  
 SIGNATURE: *Curt Kopilarscik*  
 DATE: 6-27-12 LICENSE NO. 24758

DRAWN BY BAV DATE 3-23-12  
 DESIGN BY BAV DATE 3-23-12  
 CHECKED BY JEO DATE 4-10-12





**ANOKA COUNTY  
HIGHWAY DEPT.**

S.P. 0208-145 (T.H. 65)  
 S.A.P. 002-716-013  
 S.A.P. 197-020-004

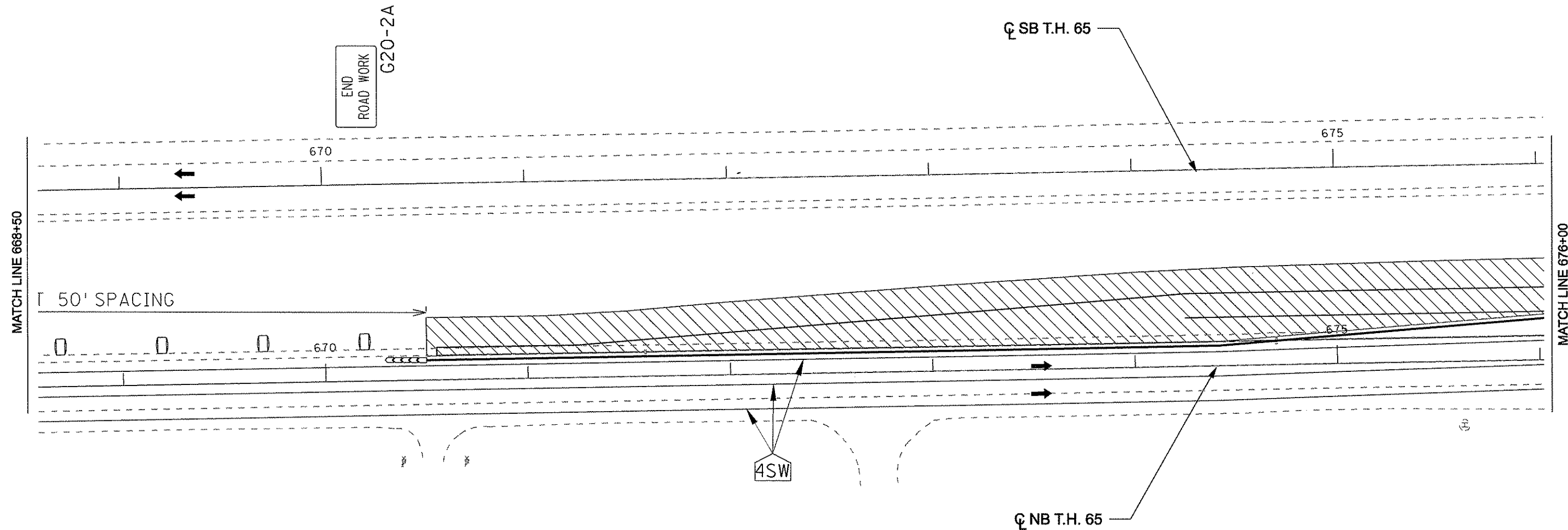
**TRAFFIC CONTROL  
STAGE 1**  
 Sheet 31 of 108 Sheets

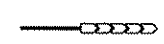

**LEGEND**

	CONSTRUCTION AREA
	CONSTRUCTION UNDER TRAFFIC
	REFLECTORIZED DRUM
	PORTABLE PRECAST CONCRETE BARRIER WITH END TREATMENTS AND REFELCTORIZATION

**STAGE 1 TRAFFIC CONTROL NOTES:**

- 1) CSAH 116 AND TH 65 REMAIN OPEN TO ALL TRAFFIC EXCEPT FOR SB TH 65 RIGHT TURN MOVEMENTS ONTO WB CSAH 116.
- 2) MNDOT FIELD MANUAL LAYOUTS AND FLAGGER SET-UPS TO BE UTILIZED TO COMPLETE PIPE CROSSINGS FROM STRUCTURES 107 & 109 WHILE WB CSAH 116 REMAINS OPEN TO TRAFFIC.
- 3) CONTRACTOR SHALL MAINTAIN 10 FT MINIMUM LEFT TURN LANE WIDTHS AND 12 FT THRU LANE WIDTHS ON TH 65.
- 4) CONTRACTOR SHALL PROVIDE 3 FT BUFFER AREA ADJACENT TO PORTABLE PRECAST CONCRETE BARRIER.

**STAGE 1 CONSTRUCTION NOTES:**

- 1) CLEAR AND GRUB.
- 2) PIPE CROSSING FROM STRUCTURES 107 & 109 SHALL BE DONE UNDER FLAGGING OPERATIONS. STUB OUT PIPE TO PROPOSED NEW CONSTRUCTION LIMITS.
- 3) CONSTRUCT SB TH 65 LEFT TURN LANE EXTENSION.
- 4) CONSTRUCTION NB TH 65 LEFT TURN LANE EXTENSION AND ADDITIONAL NB TH 65 LEFT TURN LANE.
- 5) BEGIN TRAFFIC SIGNAL RECONSTRUCTION WORK THAT IS REQUIRED/DOES NOT CONFLICT FOR STAGE 2.
- 6) COMPLETE UTILITY RELOCATIONS THIS STAGE THAT ARE REQUIRED FOR STAGE 2.
- 7) EXTEND TH 65 MEDIAN CULVERT.
- 8) COMPLETE SB TH 65 RIGHT TURN LANE/PORK CHOP ISLAND MODIFICATIONS.

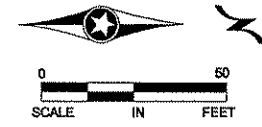

1	6/22/12	BAV	JEO	CAK	TEXT UPDATED
NO	DATE	BY	CKD	APPR	REVISION
NAME: p:\116-65\plan\116-65_TC2.dgn					

I HEREBY CERTIFY THAT THIS PLAN WAS PREPARED BY ME OR UNDER MY DIRECT SUPERVISION AND THAT I AM A DULY LICENSED PROFESSIONAL ENGINEER UNDER THE LAWS OF THE STATE OF MINNESOTA.  
 PRINT NAME: Curt Koblarcik  
 SIGNATURE: *Curt Koblarcik*  
 DATE: 6-27-12 LICENSE NO. 24756

DRAWN BY BAV DATE 3-23-12  
 DESIGN BY BAV DATE 3-23-12  
 CHECKED BY JEO DATE 4-10-12



**ANOKA COUNTY  
HIGHWAY DEPT.**

S.P. 0208-145 (T.H. 65)  
 S.A.P. 002-716-013  
 S.A.P. 197-020-004

**TRAFFIC CONTROL  
STAGE 1**

Sheet 32 of 108 Sheets



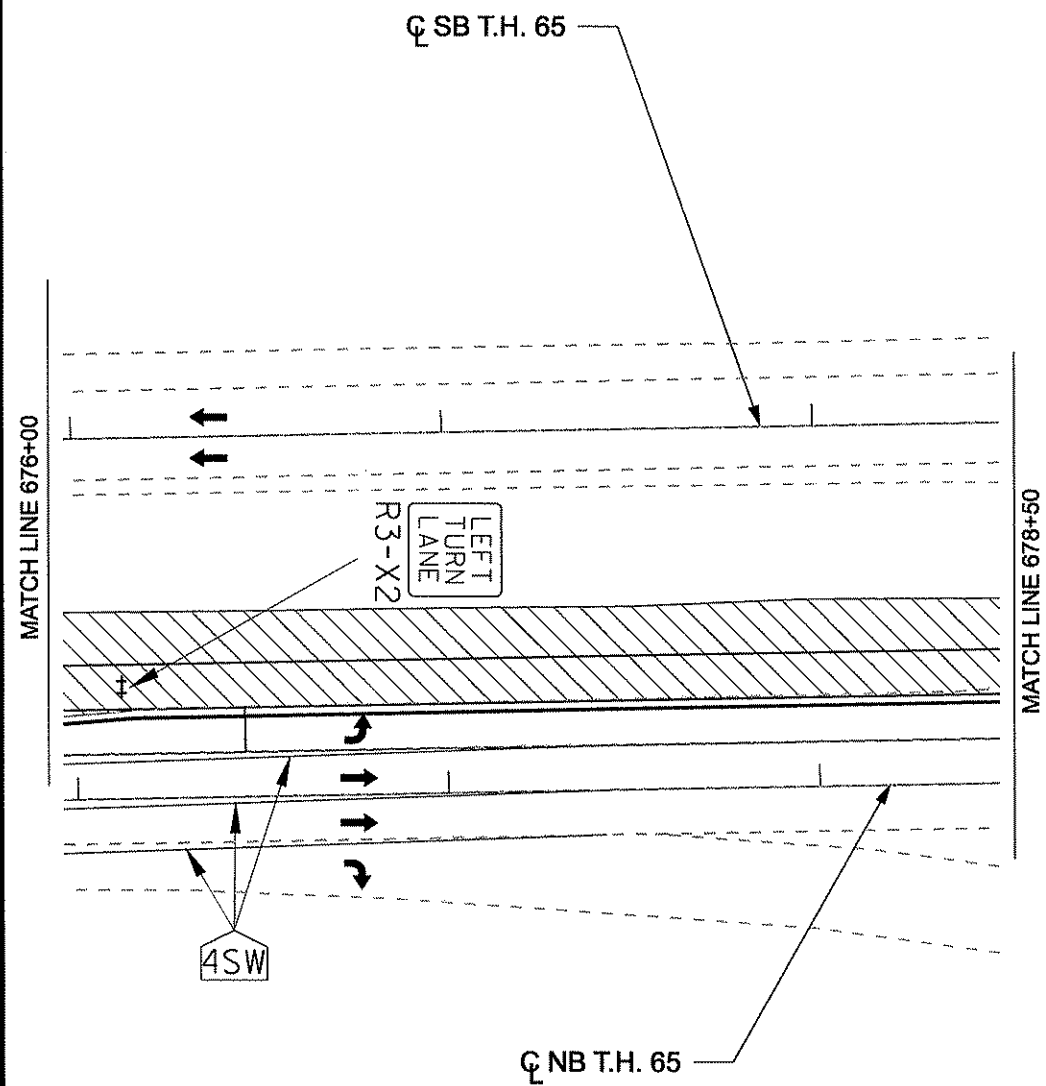

SEE SHEET 25

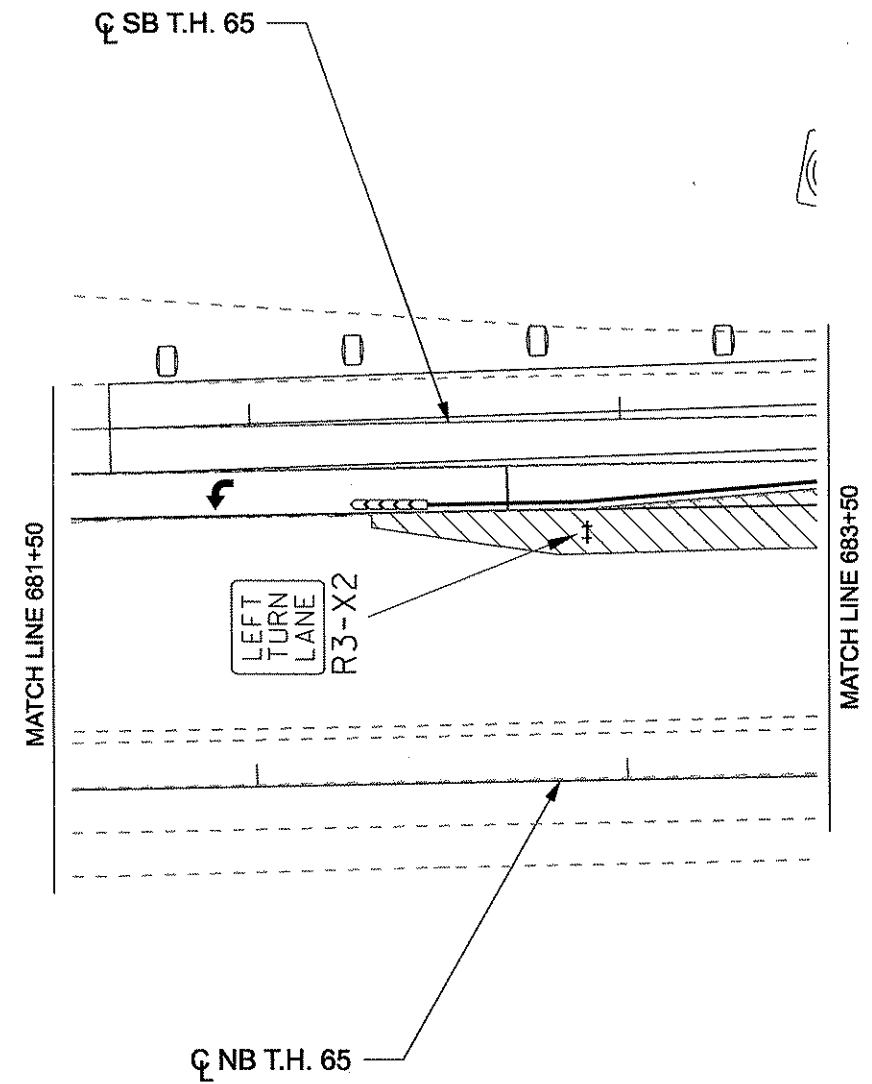

LEGEND	
	CONSTRUCTION AREA
	CONSTRUCTION UNDER TRAFFIC
	REFLECTORIZED DRUM
	PORTABLE PRECAST CONCRETE BARRIER WITH END TREATMENTS AND REFELCTORIZATION

STAGE 1 TRAFFIC CONTROL NOTES:

- 1) CSAH 116 AND TH 65 REMAIN OPEN TO ALL TRAFFIC EXCEPT FOR SB TH 65 RIGHT TURN MOVEMENTS ONTO WB CSAH 116.
- 2) MNDOT FIELD MANUAL LAYOUTS AND FLAGGER SET-UPS TO BE UTILIZED TO COMPLETE PIPE CROSSINGS FROM STRUCTURES 107 & 109 WHILE WB CSAH 116 REMAINS OPEN TO TRAFFIC.
- 3) CONTRACTOR SHALL MAINTAIN 10 FT MINIMUM LEFT TURN LANE WIDTHS AND 12 FT THRU LANE WIDTHS ON TH 65.
- 4) CONTRACTOR SHALL PROVIDE 3 FT BUFFER AREA ADJACENT TO PORTABLE PRECAST CONCRETE BARRIER.

STAGE 1 CONSTRUCTION NOTES:

- 1) CLEAR AND GRUB.
- 2) PIPE CROSSING FROM STRUCTURES 107 & 109 SHALL BE DONE UNDER FLAGGING OPERATIONS. STUB OUT PIPE TO PROPOSED NEW CONSTRUCTION LIMITS.
- 3) CONSTRUCT SB TH 65 LEFT TURN LANE EXTENSION.
- 4) CONSTRUCTION NB TH 65 LEFT TURN LANE EXTENSION AND ADDITIONAL NB TH 65 LEFT TURN LANE.
- 5) BEGIN TRAFFIC SIGNAL RECONSTRUCTION WORK THAT IS REQUIRED/DOES NOT CONFLICT FOR STAGE 2.
- 6) COMPLETE UTILITY RELOCATIONS THIS STAGE THAT ARE REQUIRED FOR STAGE 2.
- 7) EXTEND TH 65 MEDIAN CULVERT.
- 8) COMPLETE SB TH 65 RIGHT TURN LANE/PORK CHOP ISLAND MODIFICATIONS.

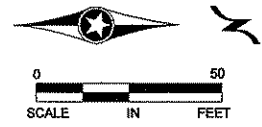

1	6/22/12	BAV	JEO	CAK	TEXT UPDATED
NO	DATE	BY	CHKD	APPR	REVISION
NAME: p:\116-65\plan\116-65_TC2.dgn					06/27/2012 9:34:56 AM

I HEREBY CERTIFY THAT THIS PLAN WAS PREPARED BY ME OR UNDER MY DIRECT SUPERVISION AND THAT I AM A DULY LICENSED PROFESSIONAL ENGINEER UNDER THE LAWS OF THE STATE OF MINNESOTA.  
 PRINT NAME: Curt Kobilarcik  
 SIGNATURE: *Curt Kobilarcik*  
 DATE: 6-27-12 LICENSE NO. 24758

DRAWN BY BAV DATE 3-23-12  
 DESIGN BY BAV DATE 3-23-12  
 CHECKED BY JEO DATE 4-10-12







ANOKA COUNTY  
 HIGHWAY DEPT.

S.P. 0208-145 (T.H. 65)  
 S.A.P. 002-716-013  
 S.A.P. 197-020-004

TRAFFIC CONTROL  
 STAGE 1  
 Sheet 33 of 108 Sheets

**LEGEND**

-  CONSTRUCTION AREA
-  CONSTRUCTION UNDER TRAFFIC
-  REFLECTORIZED DRUM
-  PORTABLE PRECAST CONCRETE BARRIER WITH END TREATMENTS AND REFLECTORIZATION

**STAGE 1 TRAFFIC CONTROL NOTES:**

- 1) CSAH 116 AND TH 65 REMAIN OPEN TO ALL TRAFFIC EXCEPT FOR SB TH 65 RIGHT TURN MOVEMENTS ONTO WB CSAH 116.
- 2) MNDOT FIELD MANUAL LAYOUTS AND FLAGGER SET-UPS TO BE UTILIZED TO COMPLETE PIPE CROSSINGS FROM STRUCTURES 107 & 109 WHILE WB CSAH 116 REMAINS OPEN TO TRAFFIC.
- 3) CONTRACTOR SHALL MAINTAIN 10 FT MINIMUM LEFT TURN LANE WIDTHS AND 12 FT THRU LANE WIDTHS ON TH 65.
- 4) CONTRACTOR SHALL PROVIDE 3 FT BUFFER AREA ADJACENT TO PORTABLE PRECAST CONCRETE BARRIER.

**STAGE 1 CONSTRUCTION NOTES:**

- 1) CLEAR AND GRUB.
- 2) PIPE CROSSING FROM STRUCTURES 107 & 109 SHALL BE DONE UNDER FLAGGING OPERATIONS. STUB OUT PIPE TO PROPOSED NEW CONSTRUCTION LIMITS.
- 3) CONSTRUCT SB TH 65 LEFT TURN LANE EXTENSION.
- 4) CONSTRUCTION NB TH 65 LEFT TURN LANE EXTENSION AND ADDITIONAL NB TH 65 LEFT TURN LANE.
- 5) BEGIN TRAFFIC SIGNAL RECONSTRUCTION WORK THAT IS REQUIRED/DOES NOT CONFLICT FOR STAGE 2.
- 6) COMPLETE UTILITY RELOCATIONS THIS STAGE THAT ARE REQUIRED FOR STAGE 2.
- 7) EXTEND TH 65 MEDIAN CULVERT.
- 8) COMPLETE SB TH 65 RIGHT TURN LANE/PORK CHOP ISLAND MODIFICATIONS.

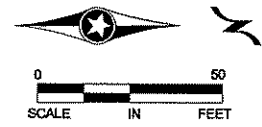
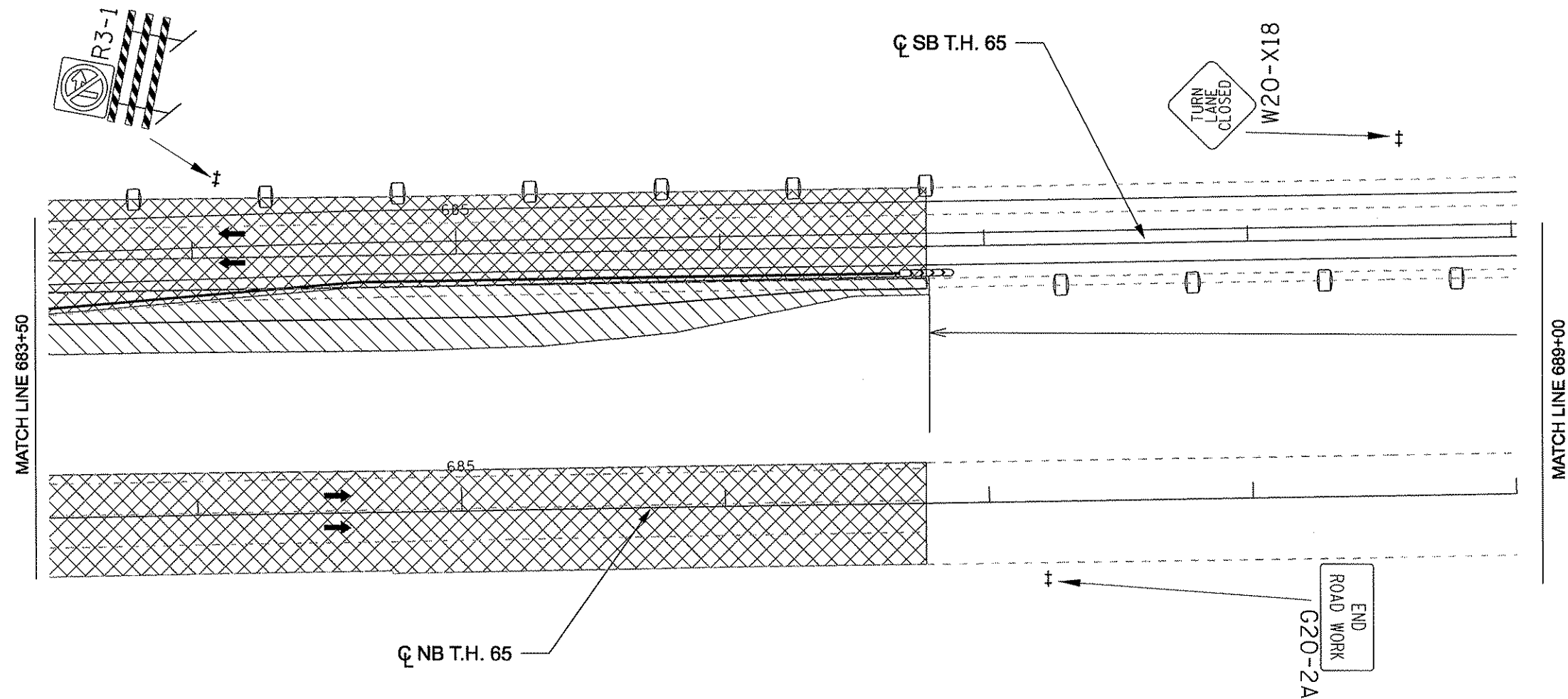

1	6/22/12	BAV	JEO	CAK	TEXT UPDATED
NO	DATE	BY	CKD	APPR	REVISION
NAME: p:\116-65\plan\116-65_TC2.dgn					
08/27/2012 8:34:58 AM					

I HEREBY CERTIFY THAT THIS PLAN WAS PREPARED BY ME OR UNDER MY DIRECT SUPERVISION AND THAT I AM A DULY LICENSED PROFESSIONAL ENGINEER UNDER THE LAWS OF THE STATE OF MINNESOTA.

PRINT NAME: Curt Kobilarcik

SIGNATURE: *Curt Kobilarcik*

DATE: 6-27-12 LICENSE NO. 24756

DRAWN BY BAV DATE 3-23-12

DESIGN BY BAV DATE 3-23-12

CHECKED BY JEO DATE 4-10-12

**ANOKA COUNTY**  
HIGHWAY DEPT.

S.P. 0208-145 (T.H. 65)  
S.A.P. 002-716-013  
S.A.P. 197-020-004



**TRAFFIC CONTROL**  
STAGE 1

Sheet 34 of 108 Sheets

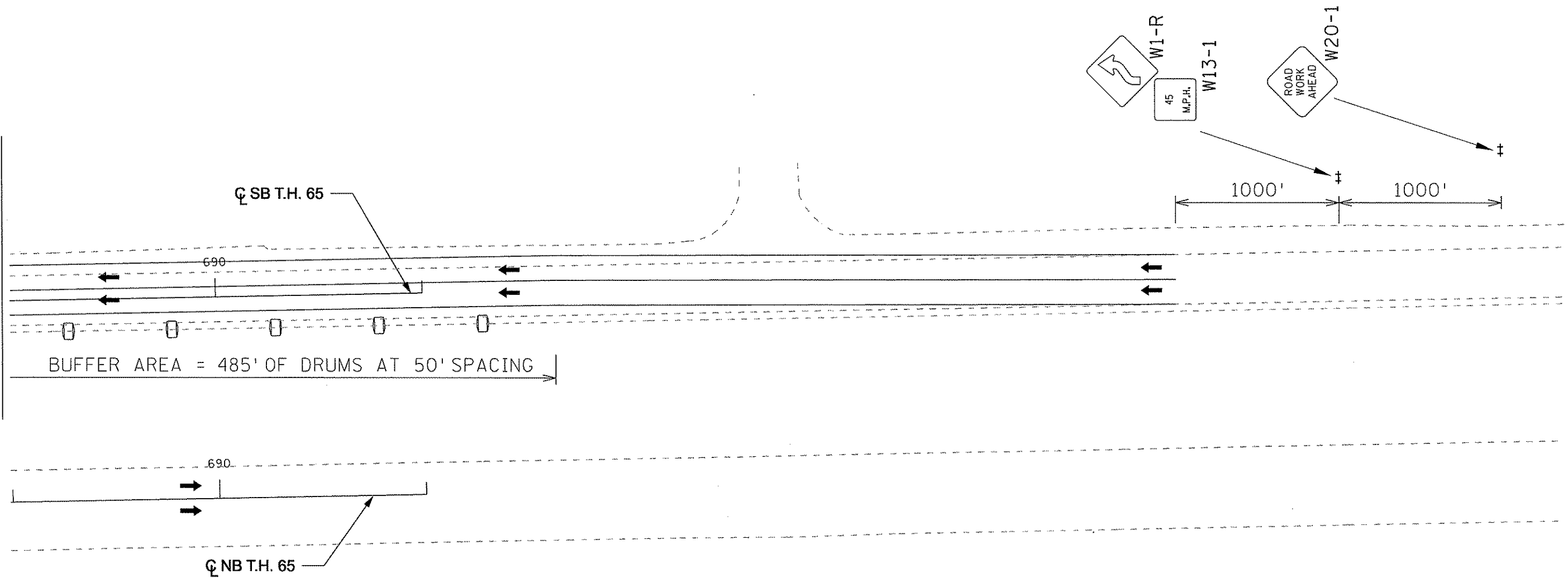
MATCH LINE 689+00

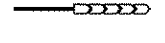

**LEGEND**

	CONSTRUCTION AREA
	CONSTRUCTION UNDER TRAFFIC
	REFLECTORIZED DRUM
	PORTABLE PRECAST CONCRETE BARRIER WITH END TREATMENTS AND REFELCTORIZATION

**STAGE 1 TRAFFIC CONTROL NOTES:**

- 1) CSAH 116 AND TH 65 REMAIN OPEN TO ALL TRAFFIC EXCEPT FOR SB TH 65 RIGHT TURN MOVEMENTS ONTO WB CSAH 116.
- 2) MNDOT FIELD MANUAL LAYOUTS AND FLAGGER SET-UPS TO BE UTILIZED TO COMPLETE PIPE CROSSINGS FROM STRUCTURES 107 & 109 WHILE WB CSAH 116 REMAINS OPEN TO TRAFFIC.
- 3) CONTRACTOR SHALL MAINTAIN 10 FT MINIMUM LEFT TURN LANE WIDTHS AND 12 FT THRU LANE WIDTHS ON TH 65.
- 4) CONTRACTOR SHALL PROVIDE 3 FT BUFFER AREA ADJACENT TO PORTABLE PRECAST CONCRETE BARRIER.

**STAGE 1 CONSTRUCTION NOTES:**

- 1) CLEAR AND GRUB.
- 2) PIPE CROSSING FROM STRUCTURES 107 & 109 SHALL BE DONE UNDER FLAGGING OPERATIONS. STUB OUT PIPE TO PROPOSED NEW CONSTRUCTION LIMITS.
- 3) CONSTRUCT SB TH 65 LEFT TURN LANE EXTENSION.
- 4) CONSTRUCTION NB TH 65 LEFT TURN LANE EXTENSION AND ADDITIONAL NB TH 65 LEFT TURN LANE.
- 5) BEGIN TRAFFIC SIGNAL RECONSTRUCTION WORK THAT IS REQUIRED/DOES NOT CONFLICT FOR STAGE 2.
- 6) COMPLETE UTILITY RELOCATIONS THIS STAGE THAT ARE REQUIRED FOR STAGE 2.
- 7) EXTEND TH 65 MEDIAN CULVERT.
- 8) COMPLETE SB TH 65 RIGHT TURN LANE/PORK CHOP ISLAND MODIFICATIONS.

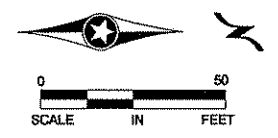

1	8/22/12	BAV	JEO	CAK	TEXT UPDATED
NO	DATE	BY	CHKD	APPR	REVISION
NAME: p:\116-65\plan\116-65_TC2.dgn					06/27/2012 8:35:00 AM

I HEREBY CERTIFY THAT THIS PLAN WAS PREPARED BY ME OR UNDER MY DIRECT SUPERVISION AND THAT I AM A DULY LICENSED PROFESSIONAL ENGINEER UNDER THE LAWS OF THE STATE OF MINNESOTA.

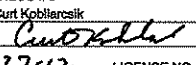
PRINT NAME: Curt Koblarcik  
 SIGNATURE:   
 DATE: 6-27-12 LICENSE NO. 24756

DRAWN BY BAV DATE 3-23-12  
 DESIGN BY BAV DATE 3-23-12  
 CHECKED BY JEO DATE 4-10-12



**ANOKA COUNTY  
HIGHWAY DEPT.**

S.P. 0208-145 (T.H. 65)  
 S.A.P. 002-716-013  
 S.A.P. 197-020-004

**TRAFFIC CONTROL  
STAGE 1**

Sheet 35 of 108 Sheets

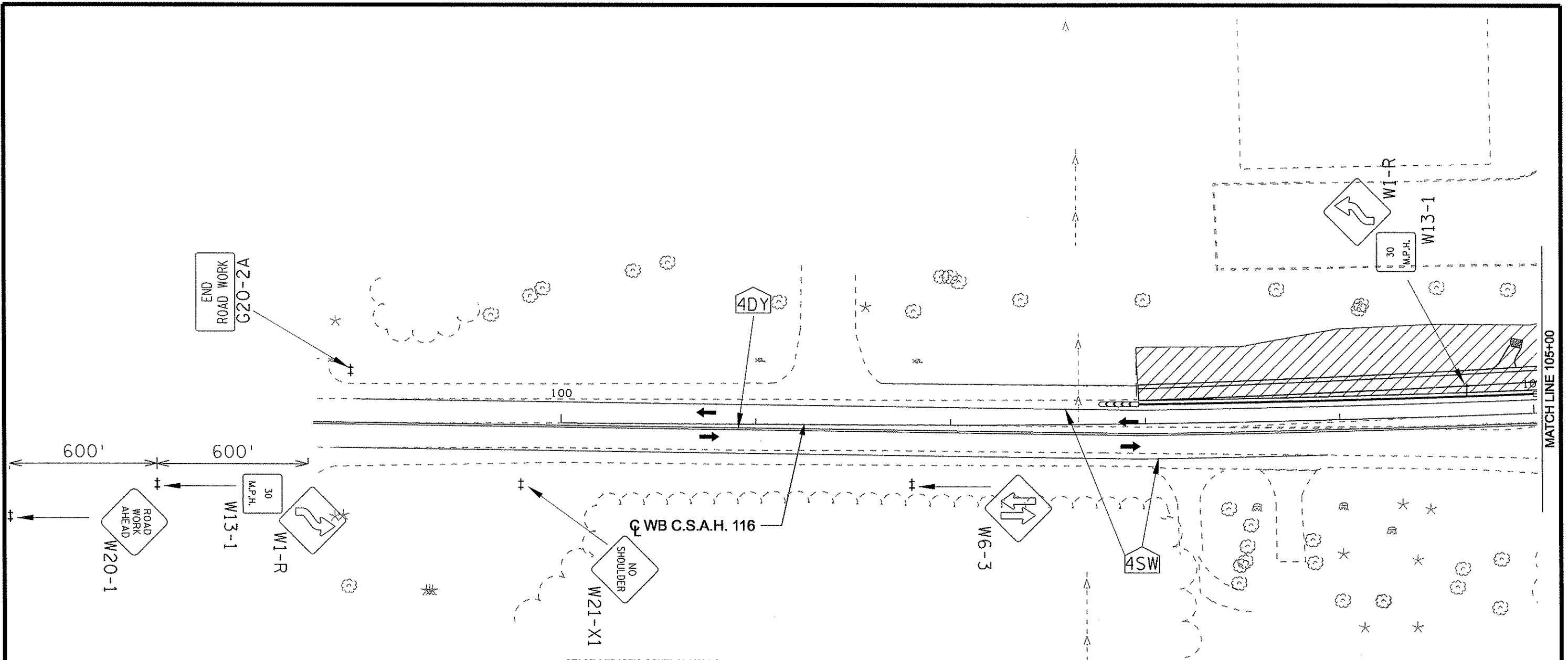

**STAGE 2 TRAFFIC CONTROL NOTES:**

- 1) CSAH 116 AND TH 65 TRAFFIC TO REMAIN OPEN TO ALL TRAFFIC.
- 2) PAVEMENT MARKINGS IN ALL TRANSITION AREAS SHALL HAVE TEMPORARY RAISED PAVEMENT MARKERS AT 10 FT INTERVALS.
- 3) EXISTING STRIPING WHICH CONFLICTS WITH TEMPORARY PAVEMENT MARKINGS SHALL BE REMOVED (WATER BLASTING REQUIRED ON ALL AREAS OF FINAL WEAR).
- 4) CONTRACTOR TO MAINTAIN 12 FT MINIMUM LANE WIDTHS ON CSAH 116.
- 5) CONTRACTOR SHALL PROVIDE 3 FT BUFFER AREA ADJACENT TO PORTABLE PRECAST CONCRETE BARRIER.
- 6) ACCESS SHALL BE MAINTAINED TO ALL DRIVEWAYS AND STREETS WITHIN THE PROJECT LIMITS DURING CONSTRUCTION.
- 7) MILL AND OVERLAY WORK ON TH 65 SHALL BE COMPLETED UNDER TRAFFIC UTILIZING THE APPROPRIATE MNDOT FIELD MANUAL LAYOUTS.
- 8) FINAL WEAR PAVING ON CSAH 116 SHALL BE COMPLETED UTILIZING THE APPROPRIATE MNDOT FIELD MANUAL LAYOUTS.

**STAGE 2 CONSTRUCTION NOTES:**

- 1) COMPLETE CLEAR AND GRUB.
- 2) REMOVE EXISTING WB CSAH 116 RT TURN LANE/SHOULDER.
- 3) CONSTRUCT STORM SEWER.
- 4) CONTINUE TRAFFIC SIGNAL RECONSTRUCTION WORK.
- 5) COMPLETE ANY REMAINING UTILITY RELOCATION WORK.
- 6) COMPLETE FINAL WEAR PAVING AND FINAL SIGNING/STRIPING ON CSAH 116.
- 7) COMPLETE TH 65 MILL AND OVERLAY AND FINAL SIGNING/STRIPING.

LEGEND	
	CONSTRUCTION AREA
	CONSTRUCTION UNDER TRAFFIC
	REFLECTORIZED DRUM
	PORTABLE PRECAST CONCRETE BARRIER WITH END TREATMENTS AND REFELCTORIZATION

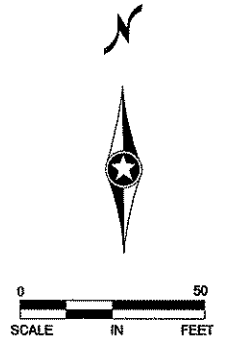

NO	DATE	BY	CHKD	APPR	REVISION
1	6/25/12	BAV	JEO	CAK	TEXT UPDATED
NAME: p:\116-65\plan\116-65_TC3.dgn					

I HEREBY CERTIFY THAT THIS PLAN WAS PREPARED BY ME OR UNDER MY DIRECT SUPERVISION AND THAT I AM A DULY LICENSED PROFESSIONAL ENGINEER UNDER THE LAWS OF THE STATE OF MINNESOTA.  
 PRINT NAME: Curt Koblarcsik  
 SIGNATURE:   
 DATE: 6-27-12 LICENSE NO. 24758

DRAWN BY BAV DATE 3-23-12  
 DESIGN BY BAV DATE 3-23-12  
 CHECKED BY JEO DATE 4-10-12



**ANOKA COUNTY  
HIGHWAY DEPT.**

S.P. 0208-145 (T.H. 65)  
 S.A.P. 002-716-013  
 S.A.P. 197-020-004

**TRAFFIC CONTROL  
STAGE 2**  
 Sheet 36 of 108 Sheets

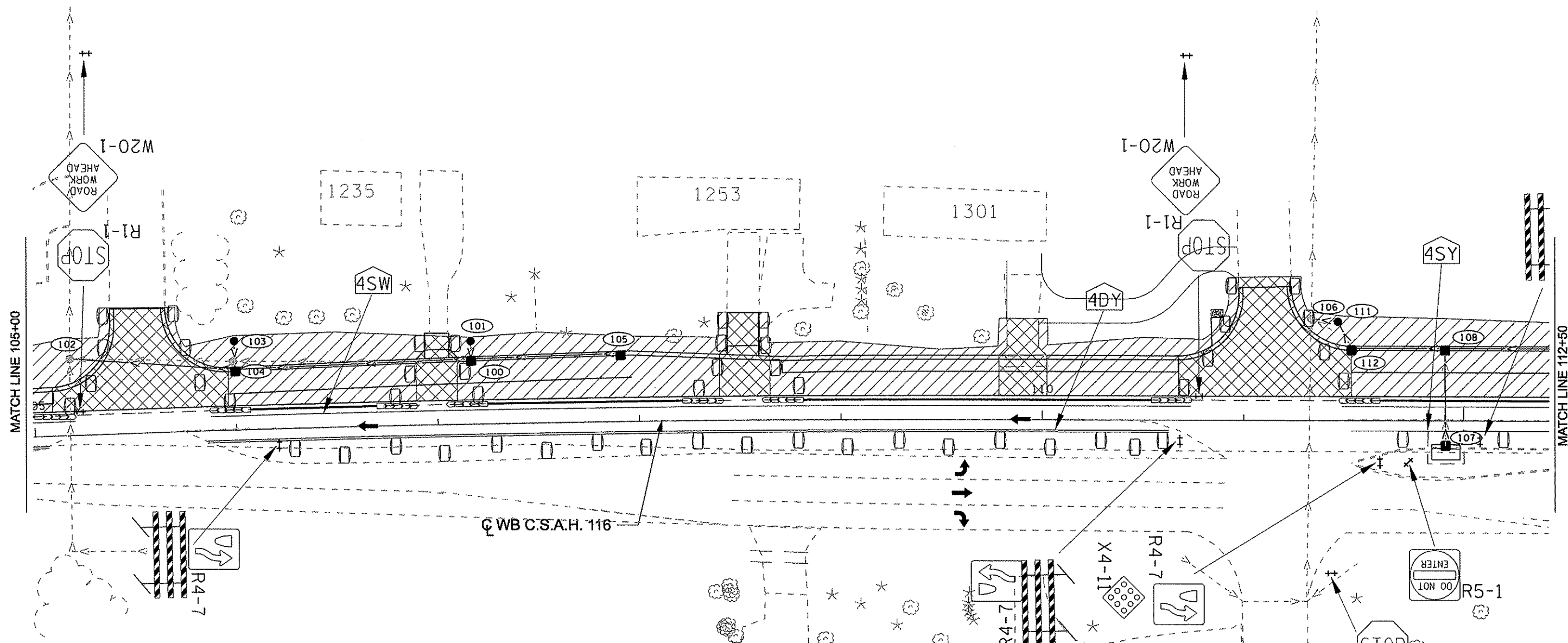

- STAGE 2 TRAFFIC CONTROL NOTES:**
- 1) CSAH 116 AND TH 65 TRAFFIC TO REMAIN OPEN TO ALL TRAFFIC.
  - 2) PAVEMENT MARKINGS IN ALL TRANSITION AREAS SHALL HAVE TEMPORARY RAISED PAVEMENT MARKERS AT 10 FT INTERVALS.
  - 3) EXISTING STRIPING WHICH CONFLICTS WITH TEMPORARY PAVEMENT MARKINGS SHALL BE REMOVED (WATER BLASTING REQUIRED ON ALL AREAS OF FINAL WEAR).
  - 4) CONTRACTOR TO MAINTAIN 12 FT MINIMUM LANE WIDTHS ON CSAH 116.
  - 5) CONTRACTOR SHALL PROVIDE 3 FT BUFFER AREA ADJACENT TO PORTABLE PRECAST CONCRETE BARRIER.
  - 6) ACCESS SHALL BE MAINTAINED TO ALL DRIVEWAYS AND STREETS WITHIN THE PROJECT LIMITS DURING CONSTRUCTION.
  - 7) MILL AND OVERLAY WORK ON TH 65 SHALL BE COMPLETED UNDER TRAFFIC UTILIZING THE APPROPRIATE MNDOT FIELD MANUAL LAYOUTS.
  - 8) FINAL WEAR PAVING ON CSAH 116 SHALL BE COMPLETED UTILIZING THE APPROPRIATE MNDOT FIELD MANUAL LAYOUTS.

- STAGE 2 CONSTRUCTION NOTES:**
- 1) COMPLETE CLEAR AND GRUB.
  - 2) REMOVE EXISTING WB CSAH 116 RT TURN LANE/SHOULDER.
  - 3) CONSTRUCT STORM SEWER.
  - 4) CONTINUE TRAFFIC SIGNAL RECONSTRUCTION WORK.
  - 5) COMPLETE ANY REMAINING UTILITY RELOCATION WORK.
  - 6) COMPLETE FINAL WEAR PAVING AND FINAL SIGNING/STRIPING ON CSAH 116.
  - 7) COMPLETE TH 65 MILL AND OVERLAY AND FINAL SIGNING AND STRIPING.

**LEGEND**

- CONSTRUCTION AREA
- CONSTRUCTION UNDER TRAFFIC
- REFLECTORIZED DRUM
- PORTABLE PRECAST CONCRETE BARRIER WITH END TREATMENTS AND REFELCTORIZATION

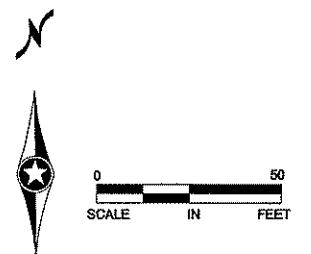

1	B/25/12	BAV	JEO	CAK	TRAFFIC CONTROL UPDATED
NO	DATE	BY	CHKD	APPR	REVISION
NAME: p:\116-65\plan\116-65_TC3.dgn					
09/27/2012 8:35:06 AM					

I HEREBY CERTIFY THAT THIS PLAN WAS PREPARED BY ME OR UNDER MY DIRECT SUPERVISION AND THAT I AM A DULY LICENSED PROFESSIONAL ENGINEER UNDER THE LAWS OF THE STATE OF MINNESOTA.

PRINT NAME: Curt Koblarosik

SIGNATURE: *Curt Koblarosik*

DATE: 6-27-12 LICENSE NO. 24756

DRAWN BY BAV DATE 3-23-12

DESIGN BY BAV DATE 3-23-12

CHECKED BY JEO DATE 4-10-12



**ANOKA COUNTY  
HIGHWAY DEPT.**

S.P. 0208-145 (T.H. 65)  
S.A.P. 002-716-013  
S.A.P. 197-020-004

**TRAFFIC CONTROL  
STAGE 2**

Sheet 37 of 108 Sheets

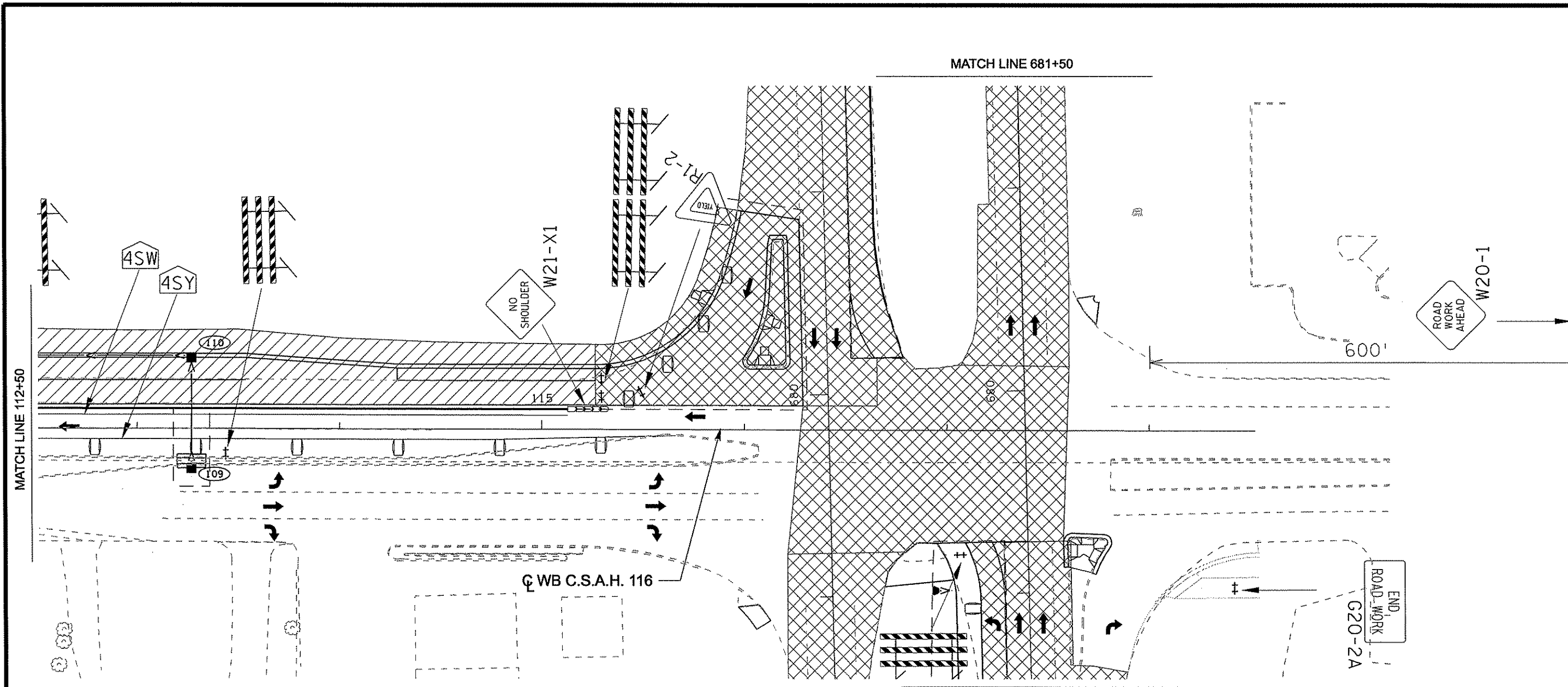





MATCH LINE 112+50

MATCH LINE 681+50

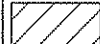
MATCH LINE 678+50

**LEGEND**

-  CONSTRUCTION AREA
-  CONSTRUCTION UNDER TRAFFIC
-  REFLECTORIZED DRUM
-  PORTABLE PRECAST CONCRETE BARRIER WITH END TREATMENTS AND REFLECTORIZATION

**STAGE 2 CONSTRUCTION NOTES:**

- 1) COMPLETE CLEAR AND GRUB.
- 2) REMOVE EXISTING WB CSAH 116 RT TURN LANE/SHOULDER.
- 3) CONSTRUCT STORM SEWER.
- 4) CONTINUE TRAFFIC SIGNAL RECONSTRUCTION WORK.
- 5) COMPLETE ANY REMAINING UTILITY RELOCATION WORK.
- 6) COMPLETE FINAL WEAR PAVING AND FINAL SIGNING/STRIPING ON CSAH 116.
- 7) COMPLETE TH 65 MILL AND OVERLAY AND FINAL SIGNING AND STRIPING.

**STAGE 2 TRAFFIC CONTROL NOTES:**

- 1) CSAH 116 AND TH 65 TRAFFIC TO REMAIN OPEN TO ALL TRAFFIC.
- 2) PAVEMENT MARKINGS IN ALL TRANSITION AREAS SHALL HAVE TEMPORARY RAISED PAVEMENT MARKERS AT 10 FT INTERVALS.
- 3) EXISTING STRIPING WHICH CONFLICTS WITH TEMPORARY PAVEMENT MARKINGS SHALL BE REMOVED (WATER BLASTING REQUIRED ON ALL AREAS OF FINAL WEAR).
- 4) CONTRACTOR TO MAINTAIN 12 FT MINIMUM LANE WIDTHS ON CSAH 116.
- 5) CONTRACTOR SHALL PROVIDE 3 FT BUFFER AREA ADJACENT TO PORTABLE PRECAST CONCRETE BARRIER.
- 6) ACCESS SHALL BE MAINTAINED TO ALL DRIVEWAYS AND STREETS WITHIN THE PROJECT LIMITS DURING CONSTRUCTION.
- 7) MILL AND OVERLAY WORK ON TH 65 SHALL BE COMPLETED UNDER TRAFFIC UTILIZING THE APPROPRIATE MNDOT FIELD MANUAL LAYOUTS.
- 8) FINAL WEAR PAVING ON CSAH 116 SHALL BE COMPLETED UTILIZING THE APPROPRIATE MNDOT FIELD MANUAL LAYOUTS.



1	6/25/12	BAV	JEO	CAK	TEXT UPDATED
NO	DATE	BY	CHKD	APPR	REVISION
NAME: p:\116-65\plan\116-65_TC3.dgn 06/27/2012 8:35:09 AM					

I HEREBY CERTIFY THAT THIS PLAN WAS PREPARED BY ME OR UNDER MY DIRECT SUPERVISION AND THAT I AM A DULY LICENSED PROFESSIONAL ENGINEER UNDER THE LAWS OF THE STATE OF MINNESOTA.  
 PRINT NAME: Curt Kobilarosik  
 SIGNATURE: *Curt Kobilarosik*  
 DATE: 6-27-12 LICENSE NO. 24756

DRAWN BY: BAV DATE: 3-23-12  
 DESIGN BY: BAV DATE: 3-23-12  
 CHECKED BY: JEO DATE: 4-10-12



**ANOKA COUNTY  
HIGHWAY DEPT.**

S.P. 0208-145 (T.H. 65)  
 S.A.P. 002-716-013  
 S.A.P. 197-020-004

**TRAFFIC CONTROL  
STAGE 2**

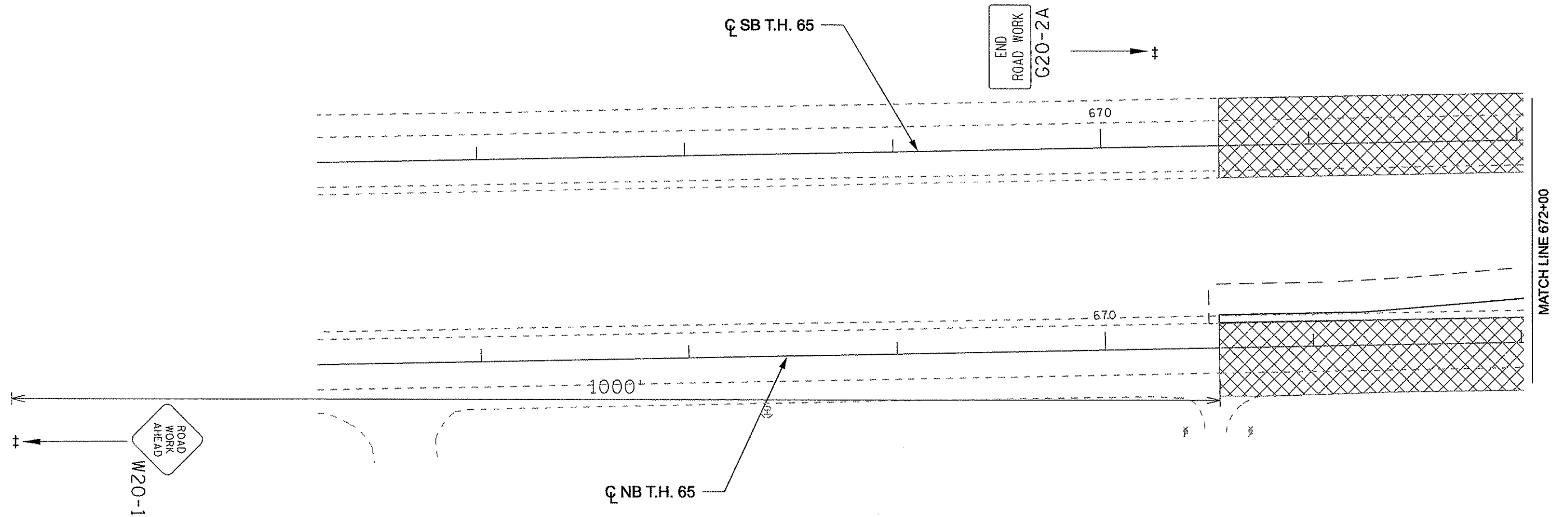

LEGEND	
	CONSTRUCTION AREA
	CONSTRUCTION UNDER TRAFFIC
	REFLECTORIZED DRUM
	PORTABLE PRECAST CONCRETE BARRIER WITH END TREATMENTS AND REFELCTORIZATION

**STAGE 2 TRAFFIC CONTROL NOTES:**

- 1) CSAH 116 AND TH 65 TRAFFIC TO REMAIN OPEN TO ALL TRAFFIC.
- 2) PAVEMENT MARKINGS IN ALL TRANSITION AREAS SHALL HAVE TEMPORARY RAISED PAVEMENT MARKERS AT 10 FT INTERVALS.
- 3) EXISTING STRIPING WHICH CONFLICTS WITH TEMPORARY PAVEMENT MARKINGS SHALL BE REMOVED (WATER BLASTING REQUIRED ON ALL AREAS OF FINAL WEAR).
- 4) CONTRACTOR TO MAINTAIN 12 FT MINIMUM LANE WIDTHS ON CSAH 116.
- 5) CONTRACTOR SHALL PROVIDE 3 FT BUFFER AREA ADJACENT TO PORTABLE PRECAST CONCRETE BARRIER.
- 6) ACCESS SHALL BE MAINTAINED TO ALL DRIVEWAYS AND STREETS WITHIN THE PROJECT LIMITS DURING CONSTRUCTION.
- 7) MILL AND OVERLAY WORK ON TH 65 SHALL BE COMPLETED UNDER TRAFFIC UTILIZING THE APPROPRIATE MNDOT FIELD MANUAL LAYOUTS.
- 8) FINAL WEAR PAVING ON CSAH 116 SHALL BE COMPLETED UTILIZING THE APPROPRIATE MNDOT FIELD MANUAL LAYOUTS.

**STAGE 2 CONSTRUCTION NOTES:**

- 1) COMPLETE CLEAR AND GRUB.
- 2) REMOVE EXISTING WB CSAH 116 RT TURN LANE/SHOULDER.
- 3) CONSTRUCT STORM SEWER.
- 4) CONTINUE TRAFFIC SIGNAL RECONSTRUCTION WORK.
- 5) COMPLETE ANY REMAINING UTILITY RELOCATION WORK.
- 6) COMPLETE FINAL WEAR PAVING AND FINAL SIGNING/STRIPING ON CSAH 116.
- 7) COMPLETE TH 65 MILL AND OVERLAY AND FINAL SIGNING AND STRIPING.

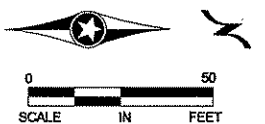

1	6/22/12	BAV	JEO	CAK	TEXT UPDATED
NO	DATE	BY	CHKD	APPR	REVISION
NAME: p:\116-65\plan\116-65_TCA.dgn					06/27/2012 8:35:13 AM

I HEREBY CERTIFY THAT THIS PLAN WAS PREPARED BY ME OR UNDER MY DIRECT SUPERVISION AND THAT I AM A DULY LICENSED PROFESSIONAL ENGINEER UNDER THE LAWS OF THE STATE OF MINNESOTA.  
 PRINT NAME: Curt Kobilercek  
 SIGNATURE:

DRAWN BY: BAV DATE: 3-23-12  
 DESIGN BY: BAV DATE: 3-23-12  
 CHECKED BY: JEO DATE: 4-10-12



**ANOKA COUNTY  
HIGHWAY DEPT.**

S.P. 0208-145 (T.H. 65)  
 S.A.P. 002-716-013  
 S.A.P. 197-020-004

**TRAFFIC CONTROL  
STAGE 2**

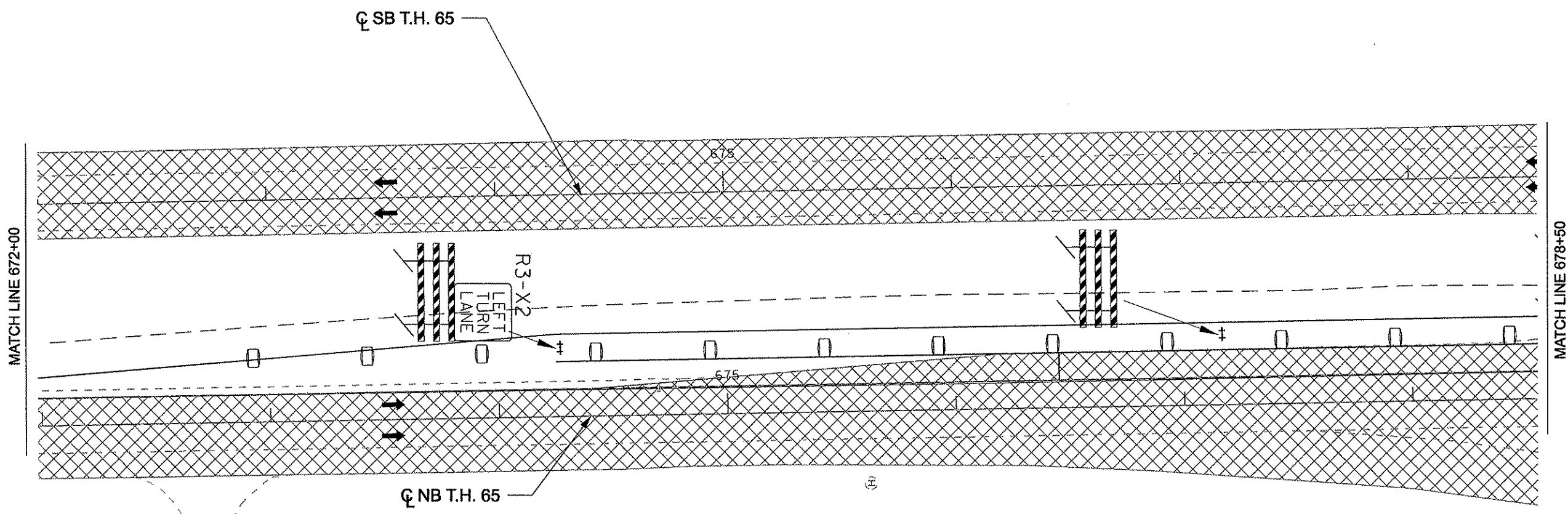

LEGEND	
	CONSTRUCTION AREA
	CONSTRUCTION UNDER TRAFFIC
	REFLECTORIZED DRUM
	PORTABLE PRECAST CONCRETE BARRIER WITH END TREATMENTS AND REFELCTORIZATION

**STAGE 2 TRAFFIC CONTROL NOTES:**

- 1) CSAH 116 AND TH 65 TRAFFIC TO REMAIN OPEN TO ALL TRAFFIC.
- 2) PAVEMENT MARKINGS IN ALL TRANSITION AREAS SHALL HAVE TEMPORARY RAISED PAVEMENT MARKERS AT 10 FT INTERVALS.
- 3) EXISTING STRIPING WHICH CONFLICTS WITH TEMPORARY PAVEMENT MARKINGS SHALL BE REMOVED (WATER BLASTING REQUIRED ON ALL AREAS OF FINAL WEAR).
- 4) CONTRACTOR TO MAINTAIN 12 FT MINIMUM LANE WIDTHS ON CSAH 116.
- 5) CONTRACTOR SHALL PROVIDE 3 FT BUFFER AREA ADJACENT TO PORTABLE PRECAST CONCRETE BARRIER.
- 6) ACCESS SHALL BE MAINTAINED TO ALL DRIVEWAYS AND STREETS WITHIN THE PROJECT LIMITS DURING CONSTRUCTION.
- 7) MILL AND OVERLAY WORK ON TH 65 SHALL BE COMPLETED UNDER TRAFFIC UTILIZING THE APPROPRIATE MNDOT FIELD MANUAL LAYOUTS.
- 8) FINAL WEAR PAVING ON CSAH 116 SHALL BE COMPLETED UTILIZING THE APPROPRIATE MNDOT FIELD MANUAL LAYOUTS.

**STAGE 2 CONSTRUCTION NOTES:**

- 1) COMPLETE CLEAR AND GRUB.
- 2) REMOVE EXISTING WB CSAH 116 RT TURN LANE/SHOULDER.
- 3) CONSTRUCT STORM SEWER.
- 4) CONTINUE TRAFFIC SIGNAL RECONSTRUCTION WORK.
- 5) COMPLETE ANY REMAINING UTILITY RELOCATION WORK.
- 6) COMPLETE FINAL WEAR PAVING AND FINAL SIGNING/STRIPING ON CSAH 116.
- 7) COMPLETE TH 65 MILL AND OVERLAY AND FINAL SIGNING AND STRIPING.

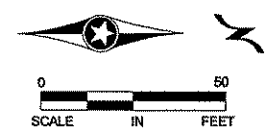

NO	DATE	BY	CHKD	APPR	REVISION
1	8/22/12	BAV	JEO	CAK	TEXT UPDATED

NAME: p:\116-65\plan\116-65\_TC4.dgn      06/27/2012      8:35:15 AM

I HEREBY CERTIFY THAT THIS PLAN WAS PREPARED BY ME OR UNDER MY DIRECT SUPERVISION AND THAT I AM A DULY LICENSED PROFESSIONAL ENGINEER UNDER THE LAWS OF THE STATE OF MINNESOTA.  
 PRINT NAME: Curt Kobilaroski  
 SIGNATURE:   
 DATE: 6-27-12 LICENSE NO. 24758

DRAWN BY BAV DATE 3-23-12  
 DESIGN BY BAV DATE 3-23-12  
 CHECKED BY JEO DATE 4-10-12



**ANOKA COUNTY  
HIGHWAY DEPT.**

S.P. 0208-145 (T.H. 65)  
 S.A.P. 002-716-013  
 S.A.P. 197-020-004

**TRAFFIC CONTROL  
STAGE 2**

Sheet 40 of 108 Sheets



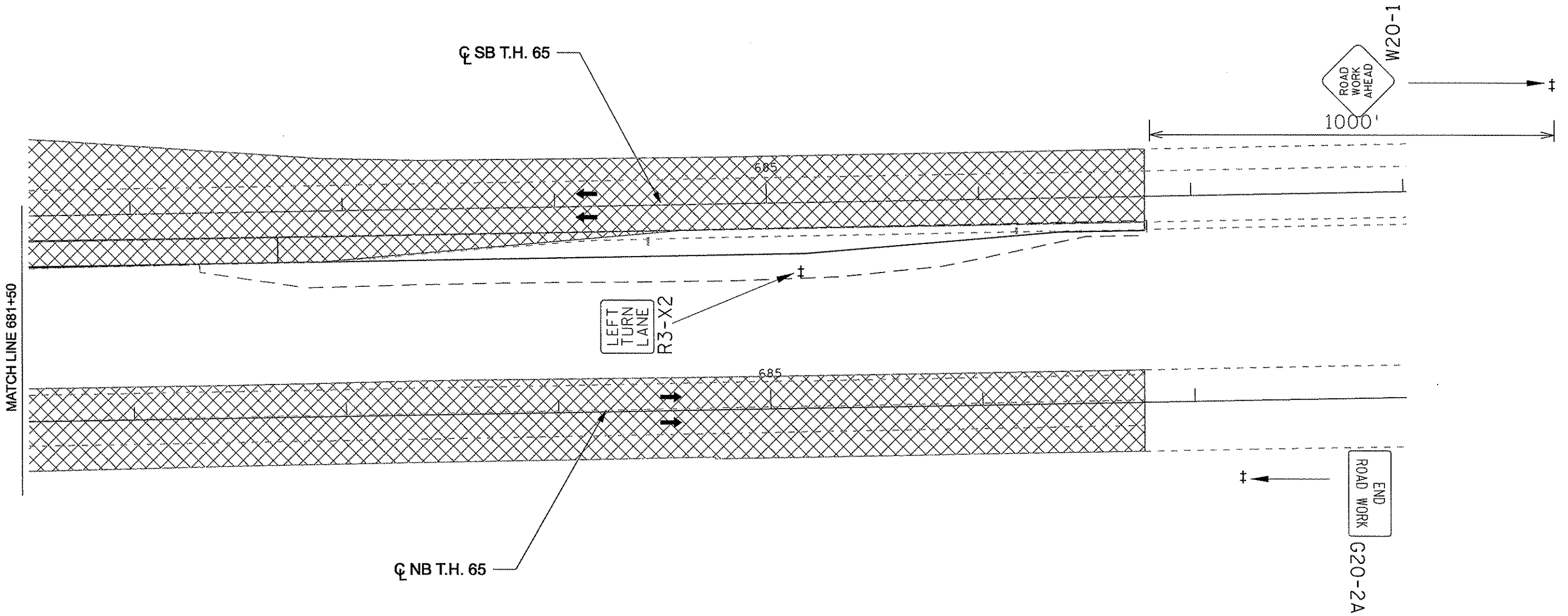

LEGEND	
	CONSTRUCTION AREA
	CONSTRUCTION UNDER TRAFFIC
	REFLECTORIZED DRUM
	PORTABLE PRECAST CONCRETE BARRIER WITH END TREATMENTS AND REFELCTORIZATION

**STAGE 2 TRAFFIC CONTROL NOTES:**

- 1) CSAH 116 AND TH 65 TRAFFIC TO REMAIN OPEN TO ALL TRAFFIC.
- 2) PAVEMENT MARKINGS IN ALL TRANSITION AREAS SHALL HAVE TEMPORARY RAISED PAVEMENT MARKERS AT 10 FT INTERVALS.
- 3) EXISTING STRIPING WHICH CONFLICTS WITH TEMPORARY PAVEMENT MARKINGS SHALL BE REMOVED (WATER BLASTING REQUIRED ON ALL AREAS OF FINAL WEAR).
- 4) CONTRACTOR TO MAINTAIN 12 FT MINIMUM LANE WIDTHS ON CSAH 116.
- 5) CONTRACTOR SHALL PROVIDE 3 FT BUFFER AREA ADJACENT TO PORTABLE PRECAST CONCRETE BARRIER.
- 6) ACCESS SHALL BE MAINTAINED TO ALL DRIVEWAYS AND STREETS WITHIN THE PROJECT LIMITS DURING CONSTRUCTION.
- 7) MILL AND OVERLAY WORK ON TH 65 SHALL BE COMPLETED UNDER TRAFFIC UTILIZING THE APPROPRIATE MNDOT FIELD MANUAL LAYOUTS.
- 8) FINAL WEAR PAVING ON CSAH 116 SHALL BE COMPLETED UTILIZING THE APPROPRIATE MNDOT FIELD MANUAL LAYOUTS.

**STAGE 2 CONSTRUCTION NOTES:**

- 1) COMPLETE CLEAR AND GRUB.
- 2) REMOVE EXISTING WB CSAH 116 RT TURN LANE/SHOULDER.
- 3) CONSTRUCT STORM SEWER.
- 4) CONTINUE TRAFFIC SIGNAL RECONSTRUCTION WORK.
- 5) COMPLETE ANY REMAINING UTILITY RELOCATION WORK.
- 6) COMPLETE FINAL WEAR PAVING AND FINAL SIGNING/STRIPING ON CSAH 116.
- 7) COMPLETE TH 65 MILL AND OVERLAY AND FINAL SIGNING AND STRIPING.

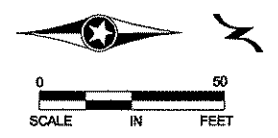

NO	DATE	BY	CHKD	APPR	REVISION
1	6/22/12	BAV	JEO	CAK	TEXT UPDATED

NAME: p:\116-65\plan\116-65\_TC4.dgn      06/27/2012      8:35:17 AM

I HEREBY CERTIFY THAT THIS PLAN WAS PREPARED BY ME OR UNDER MY DIRECT SUPERVISION AND THAT I AM A DULY LICENSED PROFESSIONAL ENGINEER UNDER THE LAWS OF THE STATE OF MINNESOTA.

PRINT NAME: Curt Kobilercaik

SIGNATURE: *Curt Kobilercaik*

DATE: 6-27-12 LICENSE NO. 24758

DRAWN BY BAV DATE 3-23-12

DESIGN BY BAV DATE 3-23-12

CHECKED BY JEO DATE 4-10-12



**ANOKA COUNTY  
HIGHWAY DEPT.**

S.P. 0208-145 (T.H. 65)  
S.A.P. 002-716-013  
S.A.P. 197-020-004

**TRAFFIC CONTROL  
STAGE 2**

Sheet 41 of 108 Sheets

M.U.T.C.D. CODE	SIZE	INSERT	QTY. STG. 1	QTY. STG. 2
R1-1	30" x 30"		3	3
R1-2	48" x 48" x 48"		0	1
R3-1	36" x 36"		2	0
R3-X2	30" x 30"		2	0
X4-11	18" x 18"		0	1
R4-7	24" x 30"		0	3
R5-1	30" x 30"		0	1
W20-1	48" x 48"		7	7
W21-X1	48" x 48"		0	2
TYPE III	8 FOOT		3	9
W1-4R	48" X 48"		2	2
G20-2A	48" X 24"		4	4
W13-1	24" X 24"		0	2
W13-1	24" X 24"		2	0
REFLECTORIZED REBOUNDABLE DRUM			61	86

M.U.T.C.D. CODE	SIZE	INSERT	QTY. STG. 1	QTY. STG. 2
W6-3	48" x 48"		0	1
W20-X18	48" x 48"		1	0
W8-1A	48" x 48"		AS NEEDED	
W8-1A	48" x 48"		AS NEEDED	
W8-8	48" x 48"		AS NEEDED	
W20-1	48" x 48"		AS NEEDED	
W8-11	48" x 48"		AS NEEDED	

TRAFFIC CONTROL NOTES:

- 1) ALL TRAFFIC CONTROL DEVICES SHALL CONFORM AND BE PLACED IN ACCORDANCE TO THE "MINNESOTA MANUAL ON TRAFFIC CONTROL DEVICES" (MN MUTCD), AND PART VI, "FIELD MANUAL FOR TEMPORARY TRAFFIC CONTROL ZONE LAYOUTS".
- 2) ALL TYPE III BARRICADES SHALL BE REFLECTORIZED ON BOTH SIDES. BARRICADES MARKINGS SHALL BE SLANTED IN ACCORDANCE WITH THE MUTCD.
- 3) PAVEMENT MARKINGS IN ALL TRANSITION AREAS SHALL HAVE TEMPORARY RAISED PAVEMENT MARKERS AT 10 FT INTERVALS.
- 4) EXISTING STRIPING WHICH CONFLICTS WITH TEMPORARY PAVEMENT MARKINGS SHALL BE REMOVED.

NO	DATE	BY	CKD	APPR	REVISION

NAME: p:\116-65\plan\116-65\_TC\_TAB.dgn 05/23/2012 9:44:56 AM

I HEREBY CERTIFY THAT THIS PLAN WAS PREPARED BY ME OR UNDER MY DIRECT SUPERVISION AND THAT I AM A DULY LICENSED PROFESSIONAL ENGINEER UNDER THE LAWS OF THE STATE OF MINNESOTA.

PRINT NAME: Curt Kobilarcsik  
SIGNATURE:   
DATE: 5-23-12 LICENSE NO. 24756

DRAWN BY: DFF DATE: 03-20-12  
DESIGN BY: DFF DATE: 03-20-12  
CHECKED BY: JEO DATE: 4-10-12

ANOKA COUNTY  
HIGHWAY DEPT.

S.P. 0208-145 (T.H. 65)  
S.A.P. 002-716-013  
S.A.P. 197-020-004

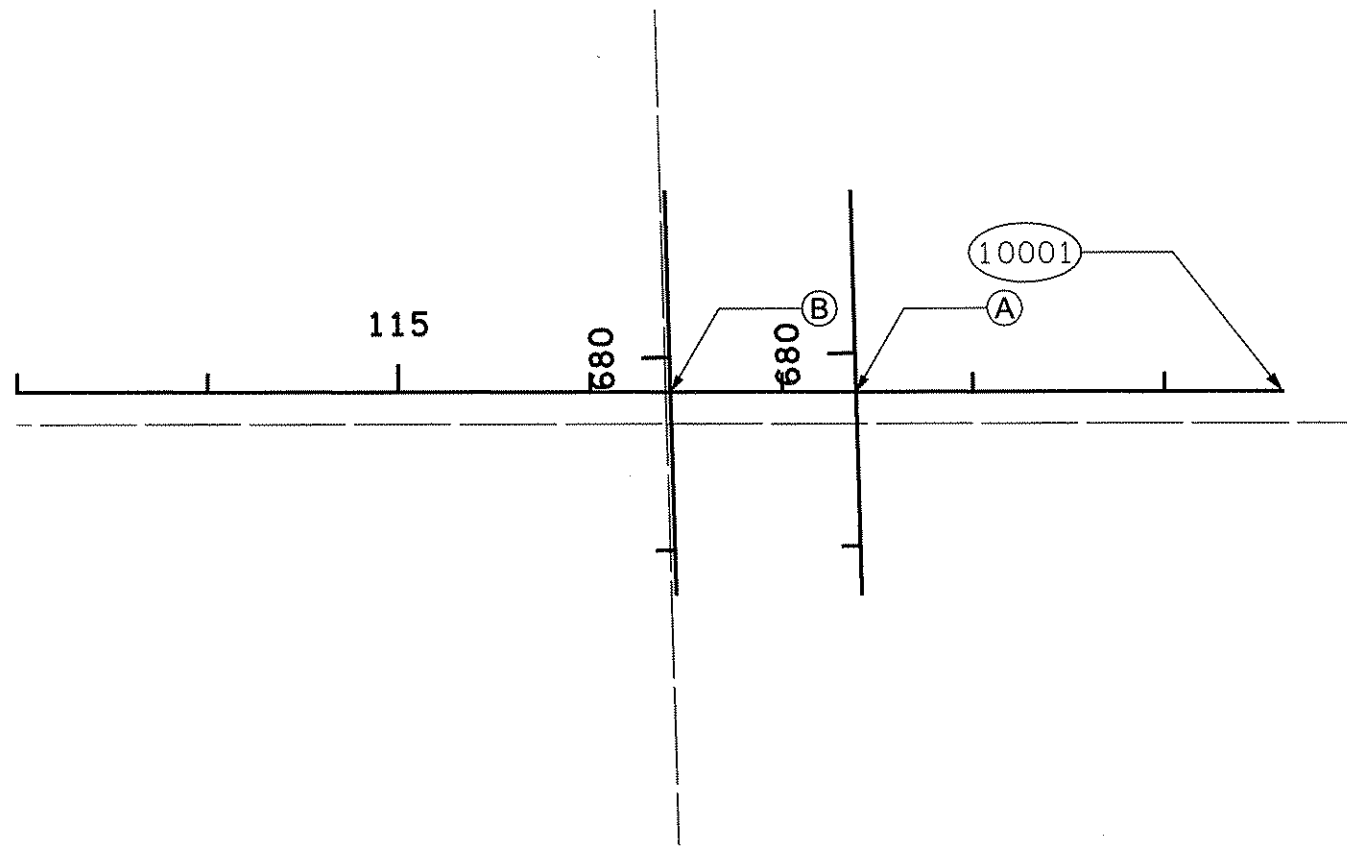
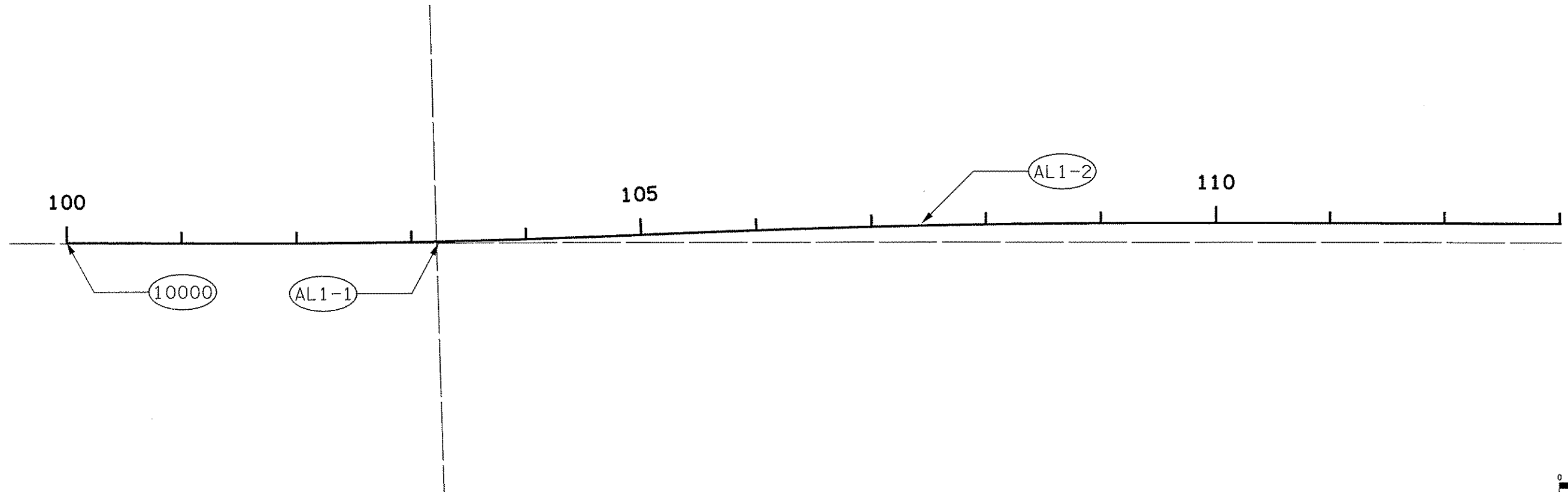

ALIGNMENT TABULATION											
POINT NUMBER	POINT	ALIGNMENT	CIRCULAR CURVE DATA					COORDINATES		AZIMUTH	
			DELTA	DEGREE	RADIUS	TANGENT	LENGTH	E	N		
Q W.B. C.S.A.H. 116 <AL1>											
10000	POT	Q.C.S.A.H. 14	100+00.000						506,580.9038	166,947.3791	
	PC		101+46.840						506,727.7413	166,946.5796	S 89° 41' 17.00" E
AL1-1	PI		103+23.191	2° 38' 41.80" LT	0° 45' 00.15"	7,639.000'	176.351'	352.639'	506,904.0895	166,945.6195	PI
	CC								506,769.3313	174,585.4664	
	PT		104+99.479						507,080.2942	166,952.7983	N 87° 40' 01.20" E
	PC		105+00.165						507,080.9797	166,952.8262	N 87° 40' 01.20" E
AL1-2	PI		107+44.755	2° 26' 44.03" RT	0° 30' 00.02"	11,459.000'	244.590'	489.106'	507,325.3673	166,962.7828	PI
	CC								507,547.4444	155,503.3244	
	PT		109+89.271						507,569.9571	166,962.3023	S 89° 53' 14.77" E
10001	POT		119+61.482						508,542.1664	166,960.3922	

Ⓐ EB C.S.A.H. 116 STA. 116+41.74 = NB T.H. 65 STA 679+82.27  
 Ⓑ EB C.S.A.H. 116 STA. 116+41.74 = SB T.H. 65 STA 679+82.36

NO	DATE	BY	CKD	APPR	REVISION

NAME: p:\116-65\plan\116-65\_AL1\_P1.dgn 05/23/2012 9:44:58 AM

I HEREBY CERTIFY THAT THIS PLAN WAS PREPARED BY ME OR UNDER MY DIRECT SUPERVISION AND THAT I AM A DULY LICENSED PROFESSIONAL ENGINEER UNDER THE LAWS OF THE STATE OF MINNESOTA.  
 PRINT NAME: Curt Kobilarcsik  
 SIGNATURE: *Curt Kobilarcsik*  
 DATE: 5-23-12 LICENSE NO. 24756

DRAWN BY: BAV DATE: 3-23-12  
 DESIGN BY: BAV DATE: 3-23-12  
 CHECKED BY: JEO DATE: 4-10-12



ANOKA COUNTY  
 HIGHWAY DEPT.

S.P. 0208-145 (T.H. 65)  
 S.A.P. 002-716-013  
 S.A.P. 197-020-004

ALIGNMENT TABULATION  
 AND PLAN  
 CSAH 116  
 Sheet 43 of 108 Sheets

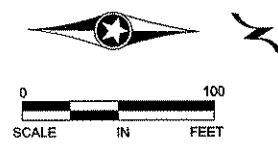
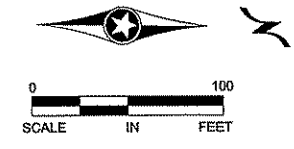
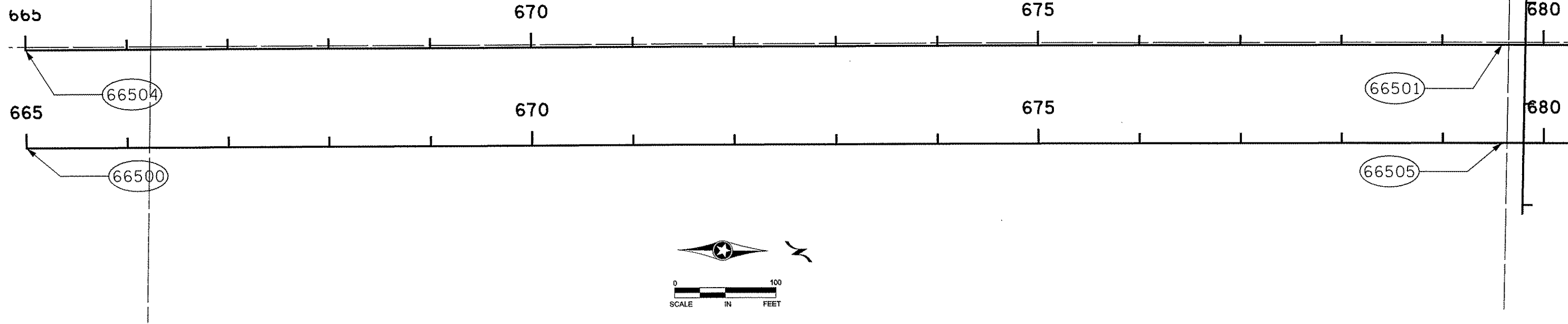

ALIGNMENT TABULATION										
POINT NUMBER	POINT	ALIGNMENT	CIRCULAR CURVE DATA					COORDINATES		AZIMUTH
			DELTA	DEGREE	RADIUS	TANGENT	LENGTH	E	N	
<b>☒ T.H. 65 &lt;NB_65A&gt;</b>										
66504	POT	☒ T.H. 65 665+00.00						508,349.6520	165,481.3305	
66505	POT	679+58.70						508,319.6551	166,939.7383	
66506	POT	690+99.53						508,297.4840	168,080.3488	
<b>☒ T.H. 65 &lt;SB_65A&gt;</b>										
66500	POT	☒ T.H. 65 665+00.00						508,252.0714	165,419.3890	
66501	POT	679+58.72						508,222.8741	169,937.8165	
66502	POT	690+99.57						508,200.5026	168,078.4467	

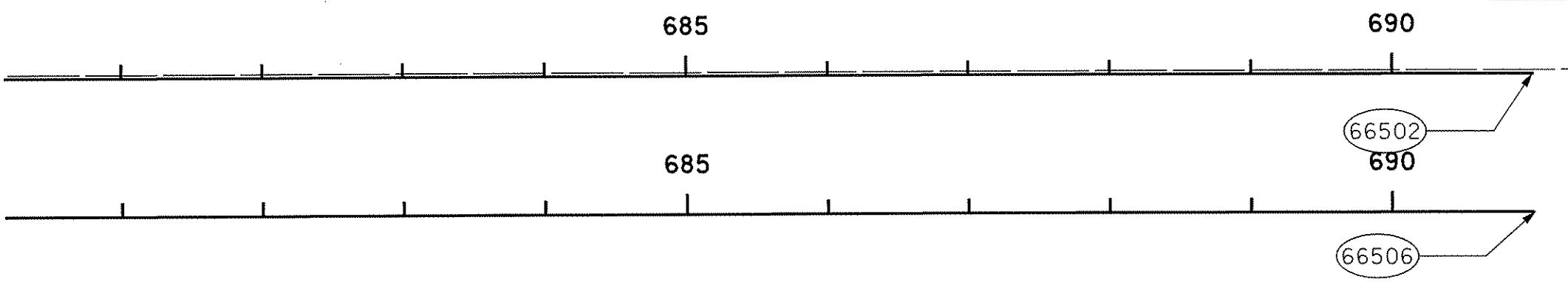

NO	DATE	BY	CKD	APPR	REVISION

NAME: p:\116-65\plan\116-65\_AL1\_P1.dgn      05/23/2012      9:44:59 AM

I HEREBY CERTIFY THAT THIS PLAN WAS PREPARED BY ME OR UNDER MY DIRECT SUPERVISION AND THAT I AM A DULY LICENSED PROFESSIONAL ENGINEER UNDER THE LAWS OF THE STATE OF MINNESOTA.

PRINT NAME: Curt Kobilarcsik  
 SIGNATURE: *Curt Kobilarcsik*  
 DATE: 5-23-12      LICENSE NO. 24756

DRAWN BY: BAV      DATE: 3-23-12  
 DESIGN BY: BAV      DATE: 3-23-12  
 CHECKED BY: JEO      DATE: 4-10-12



S.P. 0208-145 (T.H. 65)  
 S.A.P. 002-716-013  
 S.A.P. 197-020-004

ALIGNMENT TABULATION AND PLAN  
 T.H. 65  
 Sheet 44 of 108 Sheets

- NOTES:
- (A) REMOVE PIPE CULVERT
  - (B) REMOVE PIPE APRON
  - (C) SAWCUT BITUMINOUS PAVEMENT (FULL DEPTH)
  - (D) REMOVE CONCRETE SLAB
- SEE TABS FOR DETAILS

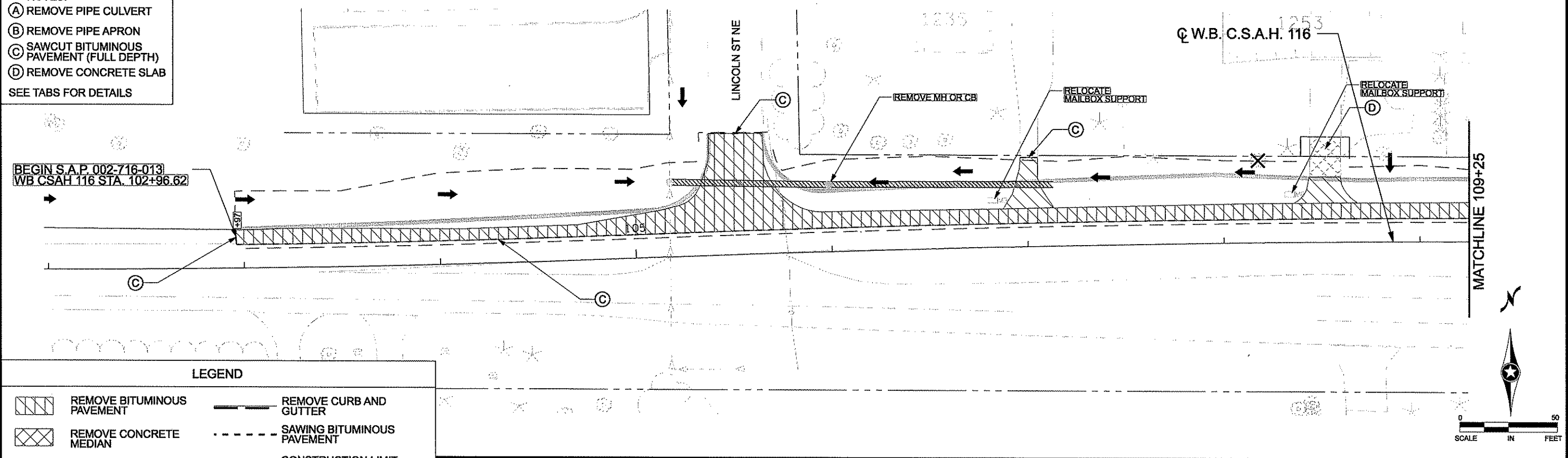

- LEGEND
- REMOVE BITUMINOUS PAVEMENT
  - REMOVE CONCRETE MEDIAN
  - TREE REMOVAL BY EACH
  - PROPOSED CURB (FOR REFERENCE ONLY)
  - FLOW DIRECTION
  - REMOVE CURB AND GUTTER
  - SAWING BITUMINOUS PAVEMENT
  - CONSTRUCTION LIMIT
  - TEMPORARY EASEMENT
  - PERMANENT EASEMENT
  - REMOVE PIPE SEWER

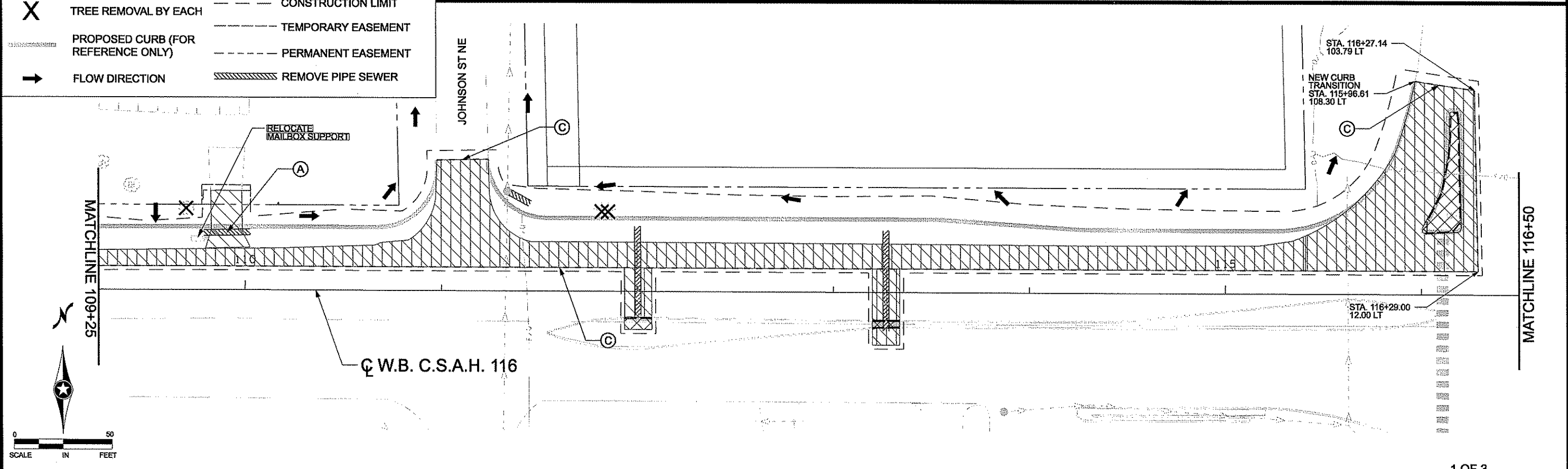

NO	DATE	BY	CHKD	APPR	REVISION
1	5/21/12	BAV	JEO	CAK	TEXT UPDATED
2	6/22/12	BAV	JEO	CAK	TEXT UPDATED

NAME: p:\116-65\plan\116-65\_RM\_P1.dgn      06/26/2012      11:42:24 AM

I HEREBY CERTIFY THAT THIS PLAN WAS PREPARED BY ME OR UNDER MY DIRECT SUPERVISION AND THAT I AM A DULY LICENSED PROFESSIONAL ENGINEER UNDER THE LAWS OF THE STATE OF MINNESOTA.

PRINT NAME: Curt Kobilaroski  
 SIGNATURE: *Curt Kobilaroski*  
 DATE: 6-27-12      LICENSE NO. 24756

DRAWN BY: BAV      DATE: 3-23-12  
 DESIGN BY: BAV      DATE: 3-23-12  
 CHECKED BY: JEO      DATE: 4-10-12

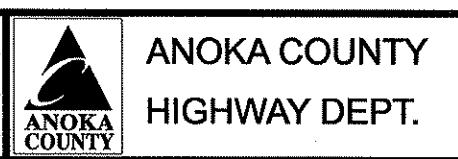

S.P. 0208-145 (T.H. 65)  
 S.A.P. 002-716-013  
 S.A.P. 197-020-004

1 OF 3

TOPOGRAPHY AND REMOVAL PLANS  
 STA 102+00 TO 116+50  
 Sheet 45 of 108 Sheets

- NOTES:
- (A) REMOVE PIPE CULVERT
  - (B) REMOVE PIPE APRON
  - (C) SAWCUT BITUMINOUS PAVEMENT (FULL DEPTH)
  - (D) REMOVE CONCRETE SLAB
- SEE TABS FOR DETAILS

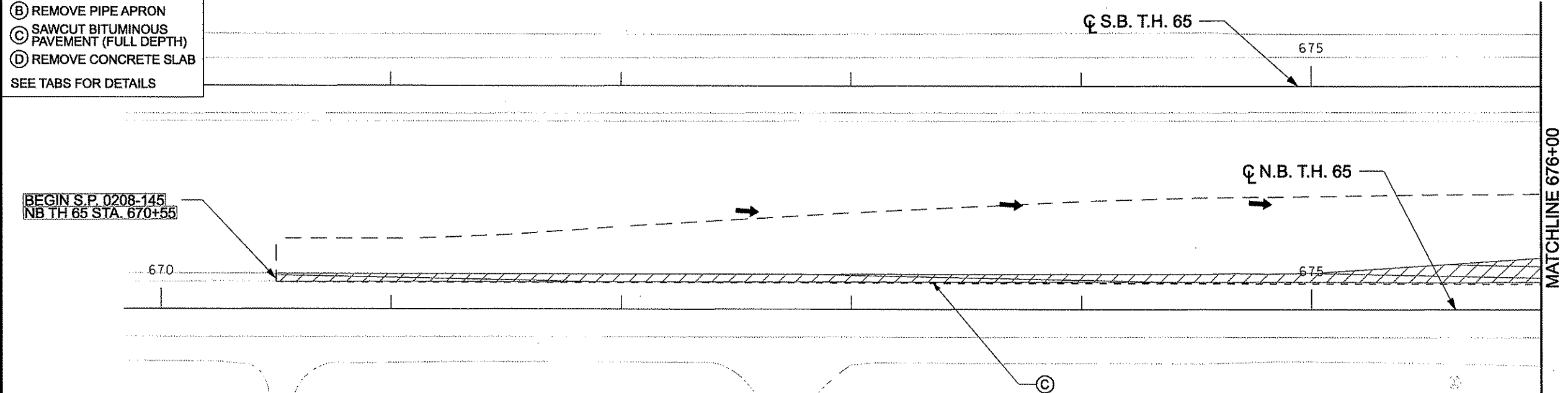

**LEGEND**

	REMOVE BITUMINOUS PAVEMENT		REMOVE CURB AND GUTTER
	REMOVE CONCRETE MEDIAN		SAWING BITUMINOUS PAVEMENT
	TREE REMOVAL BY EACH		CONSTRUCTION LIMIT
	PROPOSED CURB (FOR REFERENCE ONLY)		TEMPORARY EASEMENT
	FLOW DIRECTION		PERMANENT EASEMENT
			REMOVE PIPE SEWER

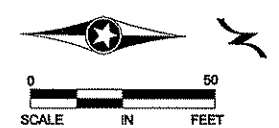
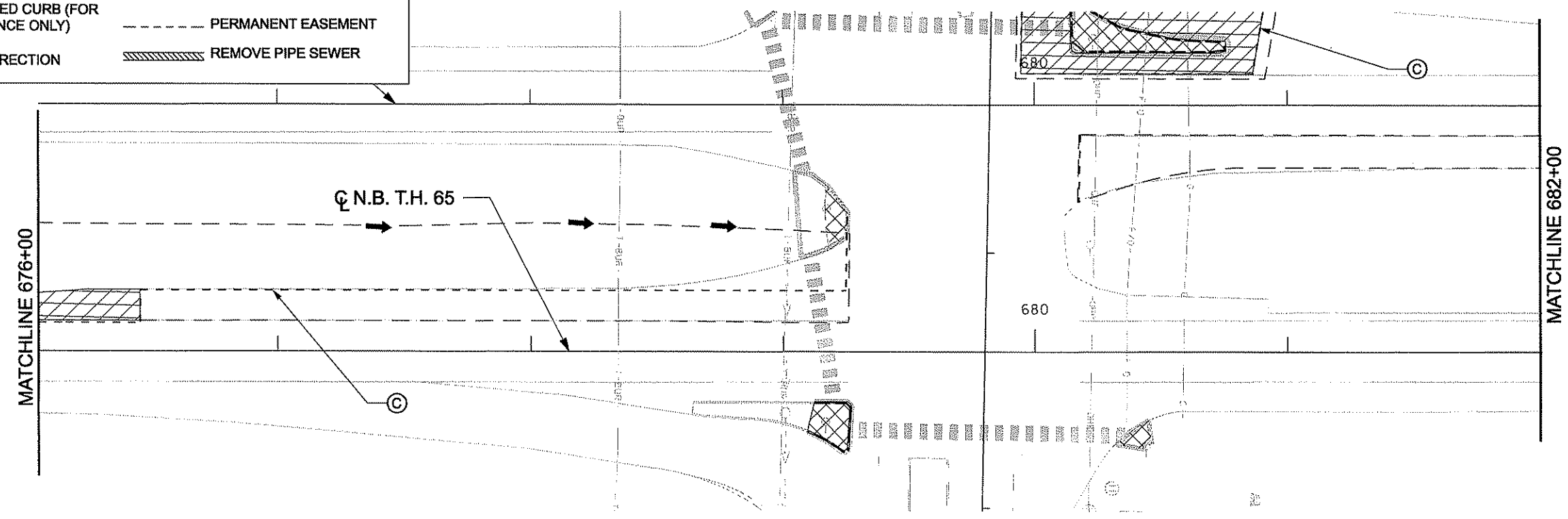
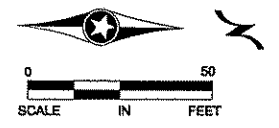

2 OF 3

NO	DATE	BY	CHKD	APPR	REVISION
1	5/21/12	BAV	JEO	CAK	TEXT UPDATED

NAME: p:\116-65\plan\116-65\_RM\_P2.dgn      08/28/2012      11:42:27 AM

I HEREBY CERTIFY THAT THIS PLAN WAS PREPARED BY ME OR UNDER MY DIRECT SUPERVISION AND THAT I AM A DULY LICENSED PROFESSIONAL ENGINEER UNDER THE LAWS OF THE STATE OF MINNESOTA.

PRINT NAME: Curt Kobilarcik  
 SIGNATURE: *Curt Kobilarcik*  
 DATE: 6-27-12      LICENSE NO. 24758

DRAWN BY: BAV      DATE: 3-23-12  
 DESIGN BY: BAV      DATE: 3-23-12  
 CHECKED BY: JEO      DATE: 4-10-12



**ANOKA COUNTY  
HIGHWAY DEPT.**

S.P. 0208-145 (T.H. 65)  
 S.A.P. 002-716-013  
 S.A.P. 197-020-004

**TOPOGRAPHY AND  
REMOVAL PLANS**

STA 670+00 TO 682+00

Sheet 46 of 108 Sheets

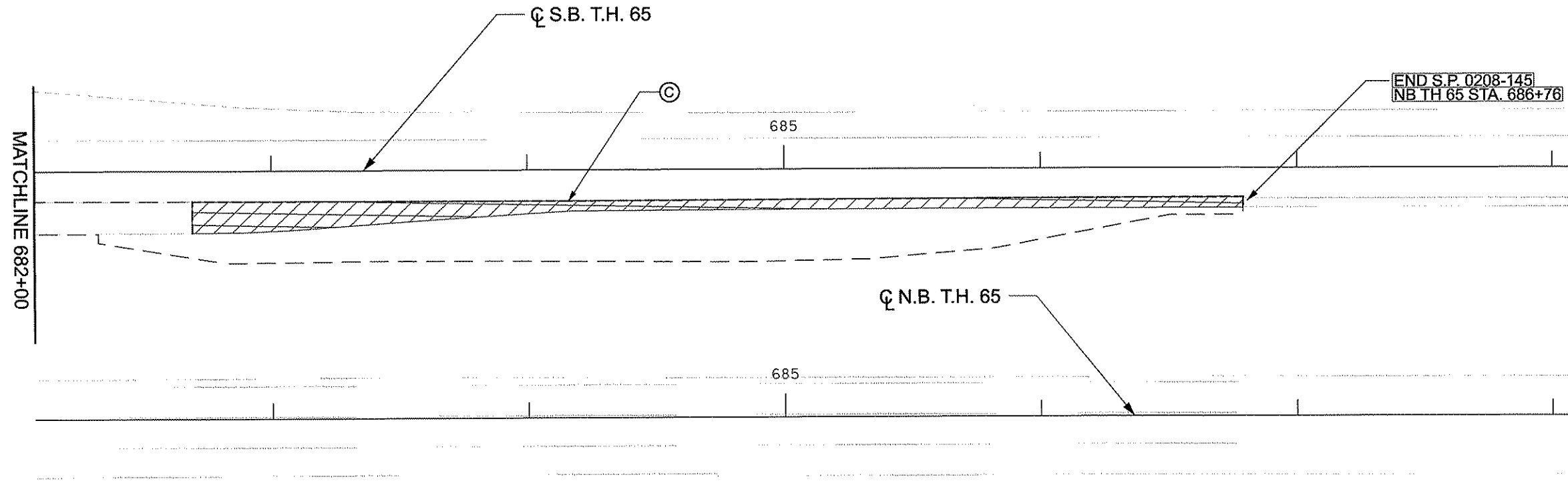

LEGEND	
	REMOVE BITUMINOUS PAVEMENT
	REMOVE CONCRETE
	TREE REMOVAL BY EACH
	SAWING BITUMINOUS PAVEMENT
	PROPOSED CURB (FOR REFERENCE ONLY)
	FLOW DIRECTION
	REMOVE CURB AND GUTTER
	CONSTRUCTION LIMIT
	TEMPORARY EASEMENT
	PERMANENT EASEMENT
	REMOVE PIPE SEWER

NOTES:  
 (A) REMOVE PIPE CULVERT  
 (B) REMOVE PIPE APRON  
 (C) SAWCUT BITUMINOUS PAVEMENT (FULL DEPTH)  
 (D) REMOVE CONCRETE SLAB  
 SEE TABS FOR DETAILS

NO	DATE	BY	CKD	APPR	REVISION
1	5/21/12	BAV	JEO	CAK	TEXT UPDATED

NAME: p:\116-65\plan\116-65\_RM\_P3.dgn      05/23/2012      9:45:11 AM

I HEREBY CERTIFY THAT THIS PLAN WAS PREPARED BY ME OR UNDER MY DIRECT SUPERVISION AND THAT I AM A DULY LICENSED PROFESSIONAL ENGINEER UNDER THE LAWS OF THE STATE OF MINNESOTA.  
 PRINT NAME: Curt Kobilarcik  
 SIGNATURE:   
 DATE: 5-23-12      LICENSE NO. 24756

DRAWN BY: BAV      DATE: 3-23-12  
 DESIGN BY: BAV      DATE: 3-23-12  
 CHECKED BY: JEO      DATE: 4-10-12

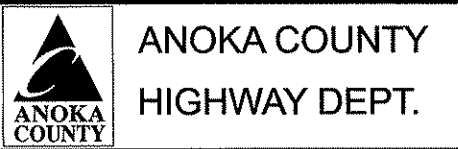

S.P. 0208-145 (T.H. 65)  
 S.A.P. 002-716-013  
 S.A.P. 197-020-004

TOPOGRAPHY AND REMOVALS PLAN  
 STA 682+00 TO 686+79  
 Sheet 47 of 108 Sheets

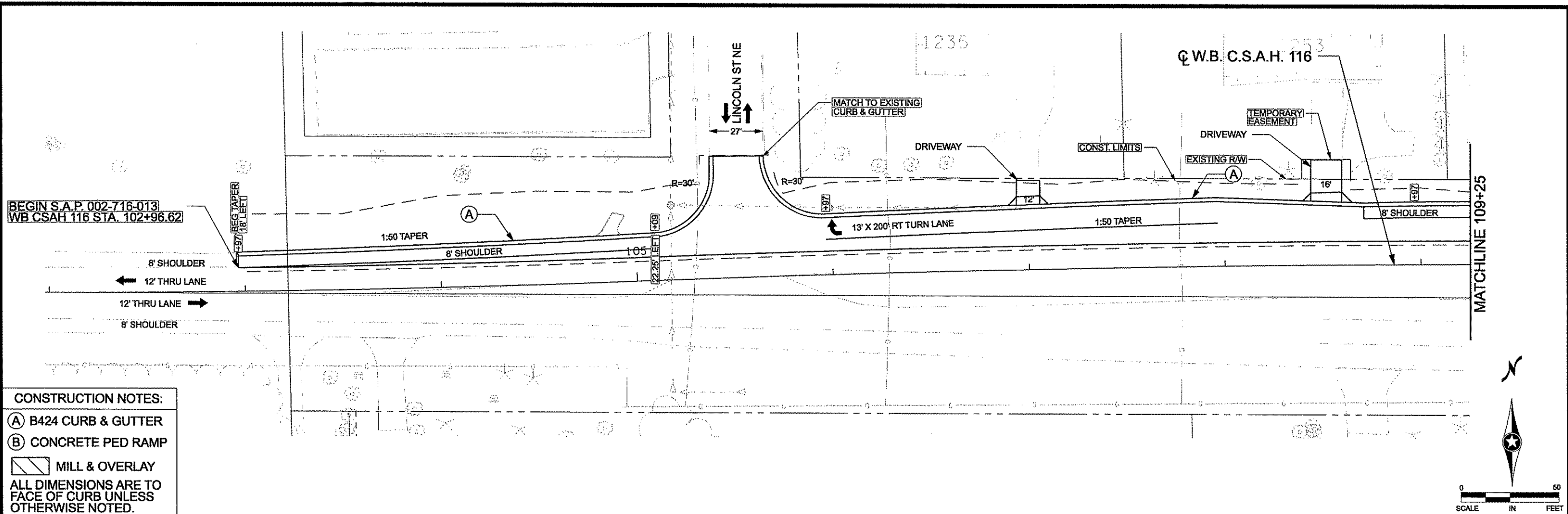

**CONSTRUCTION NOTES:**

- (A) B424 CURB & GUTTER
- (B) CONCRETE PED RAMP
- MILL & OVERLAY

ALL DIMENSIONS ARE TO FACE OF CURB UNLESS OTHERWISE NOTED.

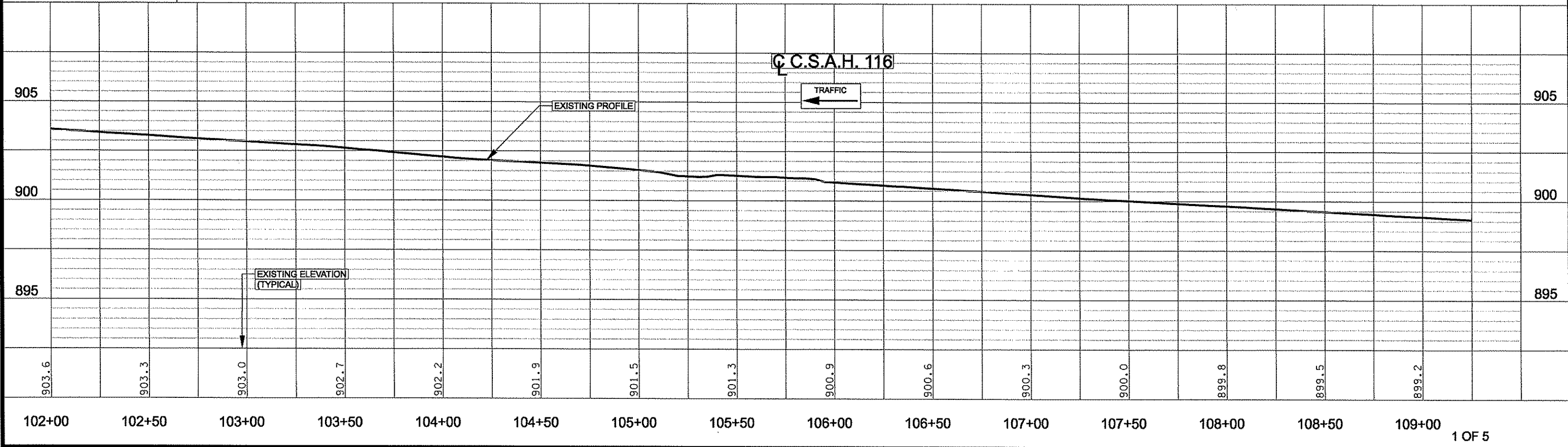
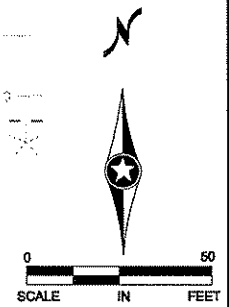

1 5/21/12 BAV JEO CAK TEXT UPDATED						I HEREBY CERTIFY THAT THIS PLAN WAS PREPARED BY ME OR UNDER MY DIRECT SUPERVISION AND THAT I AM A DULY LICENSED PROFESSIONAL ENGINEER UNDER THE LAWS OF THE STATE OF MINNESOTA. PRINT NAME: <u>Curt Kobilarcsik</u> SIGNATURE: <u>Curt Kobilarcsik</u> DATE: <u>6-27-12</u> LICENSE NO. <u>24758</u>	DRAWN BY: <u>BAV</u> DATE: <u>3-23-12</u> DESIGN BY: <u>BAV</u> DATE: <u>3-23-12</u> CHECKED BY: <u>JEO</u> DATE: <u>4-10-12</u>		<b>ANOKA COUNTY</b> <b>HIGHWAY DEPT.</b>	S.P. 0208-145 (T.H. 65) S.A.P. 002-716-013 S.A.P. 197-020-004	<b>CONSTRUCTION</b> <b>PLAN &amp; PROFILE</b> STA <u>102+00</u> TO <u>109+25</u> Sheet <u>48</u> of <u>108</u> Sheets
2 6/22/12 BAV JEO CAK TEXT UPDATED											
NO	DATE	BY	CHKD	APPR	REVISION	NAME: p:\116-65\plan\116-65_PP_P1.dgn 06/28/2012 11:42:30 AM					



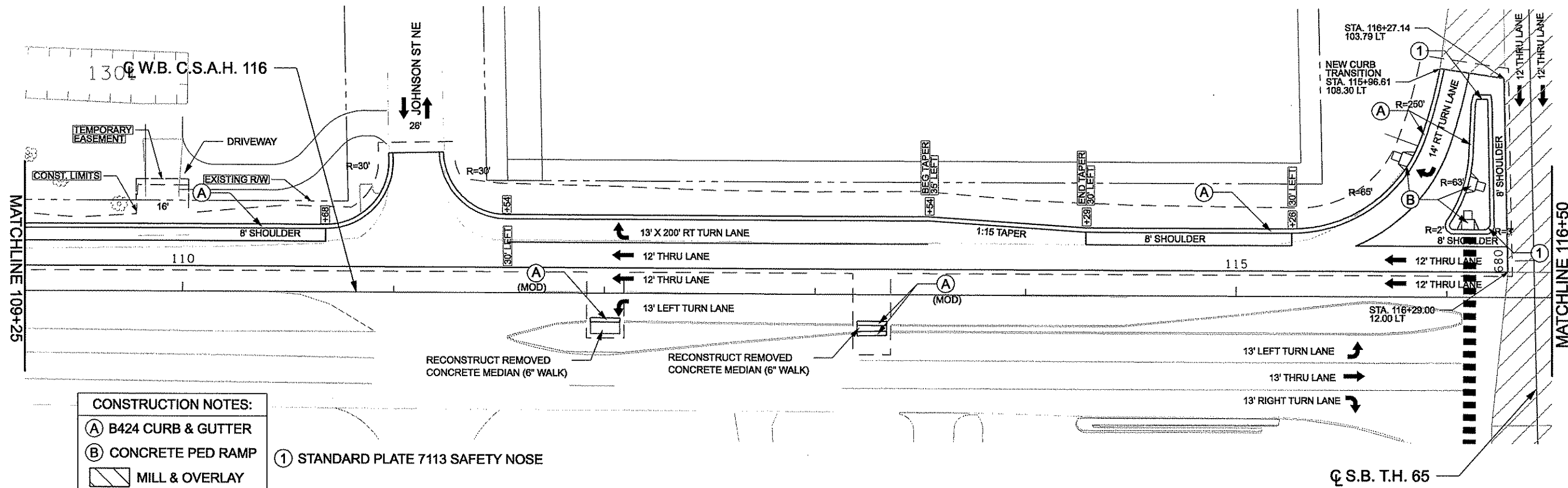

**CONSTRUCTION NOTES:**

- (A) B424 CURB & GUTTER
- (B) CONCRETE PED RAMP
- (1) STANDARD PLATE 7113 SAFETY NOSE
- MILL & OVERLAY

ALL DIMENSIONS ARE TO FACE OF CURB UNLESS OTHERWISE NOTED.

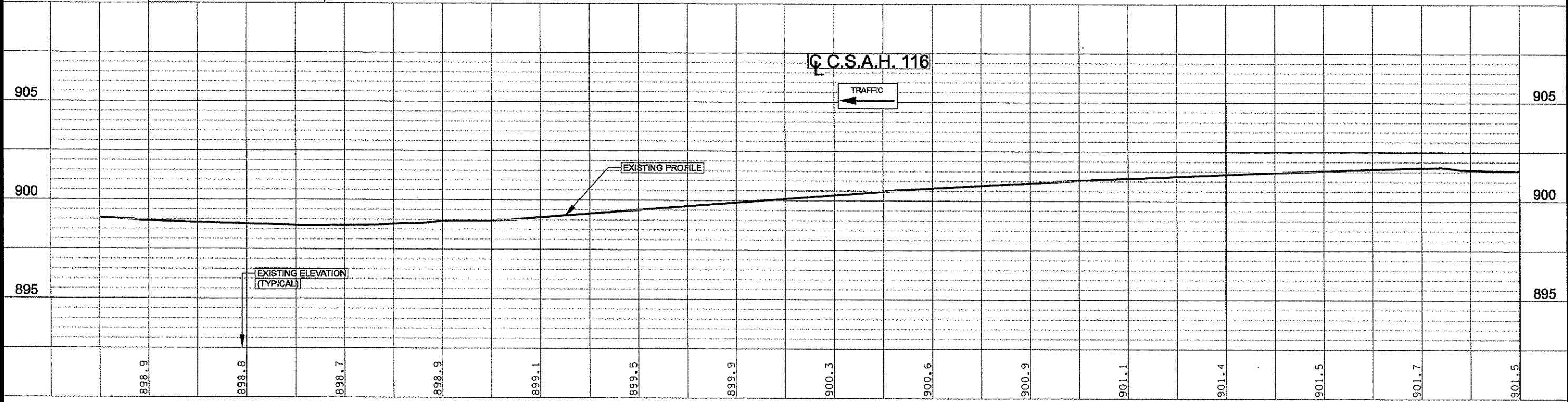
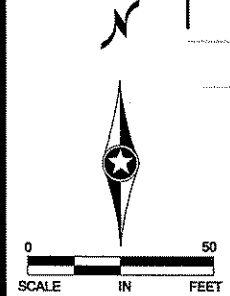

898.9	898.8	898.7	898.9	899.1	899.5	899.9	900.3	900.6	900.9	901.1	901.4	901.5	901.7	901.5
109+50	110+00	110+50	111+00	111+50	112+00	112+50	113+00	113+50	114+00	114+50	115+00	115+50	116+00	116+50

1	5/21/12	BAV	JEO	CAK	TEXT UPDATED
2	6/22/12	BAV	JEO	CAK	TEXT UPDATED
NO	DATE	BY	CKD	APPR	REVISION
NAME: p:\116-65\plan\116-65_PP_P2.dgn					
DATE: 06/26/2012 11:42:33 AM					

I HEREBY CERTIFY THAT THIS PLAN WAS PREPARED BY ME OR UNDER MY DIRECT SUPERVISION AND THAT I AM A DULY LICENSED PROFESSIONAL ENGINEER UNDER THE LAWS OF THE STATE OF MINNESOTA.

PRINT NAME: Curt Koblarski  
 SIGNATURE: *Curt Koblarski*  
 DATE: 6-27-12 LICENSE NO. 24756

DRAWN BY: BAV DATE: 3-23-12  
 DESIGN BY: BAV DATE: 3-23-12  
 CHECKED BY: JEO DATE: 4-10-12

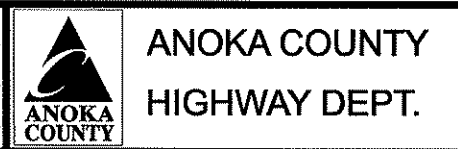

S.P. 0208-145 (T.H. 65)  
 S.A.P. 002-716-013  
 S.A.P. 197-020-004

CONSTRUCTION PLAN & PROFILE  
 STA 109+25 TO 116+50  
 Sheet 49 of 108 Sheets

CONSTRUCTION NOTES:  
 (A) B424 CURB & GUTTER  
 (B) CONCRETE PED RAMP  
 ▨ MILL & OVERLAY  
 ALL DIMENSIONS ARE TO FACE OF CURB UNLESS OTHERWISE NOTED.

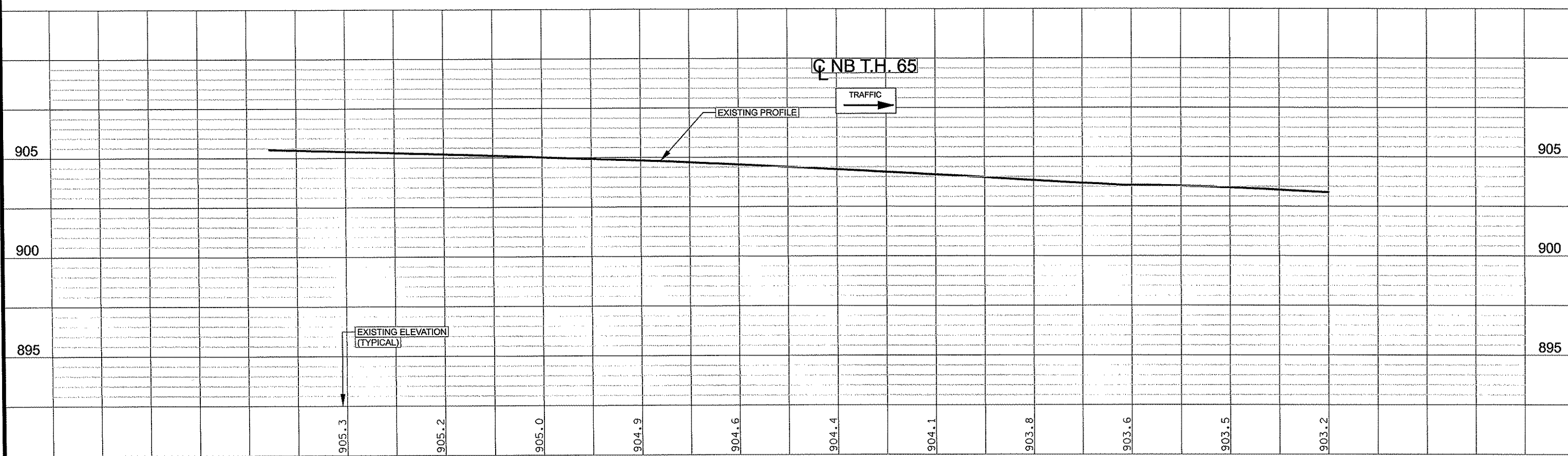
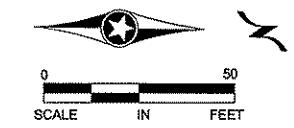
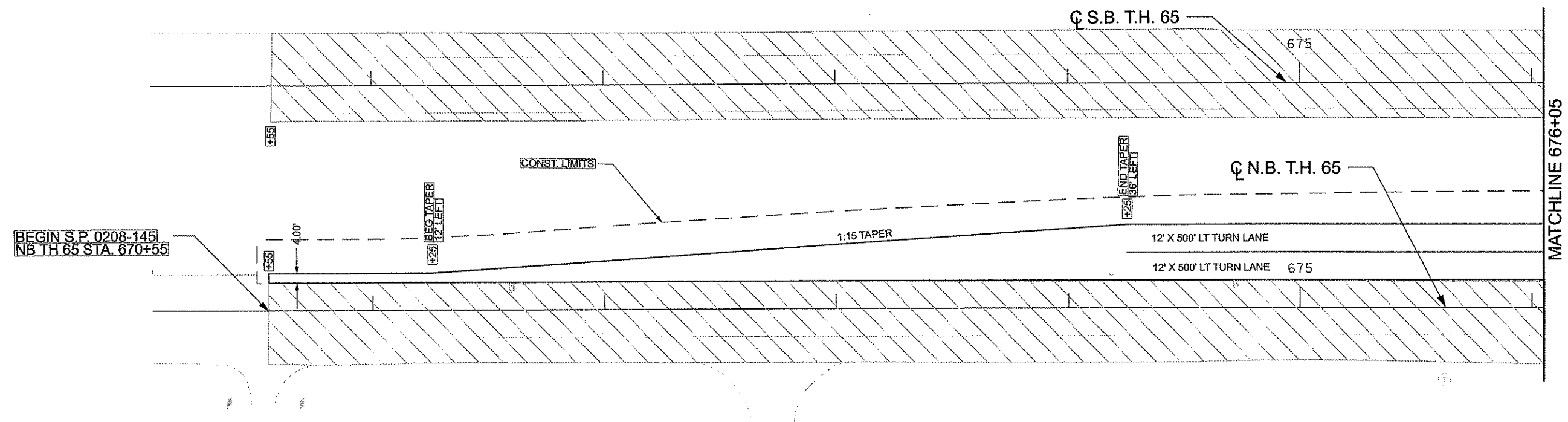

671+00    671+50    672+00    672+50    673+00    673+50    674+00    674+50    675+00    675+50    676+00

3 OF 5

1	5/21/12	BAV	JEO	CAK	TEXT UPDATED
NO	DATE	BY	CHKD	APPR	REVISION

NAME: p:\116-65\plan\116-65\_PP\_P3.dgn    05/23/2012    9:45:21 AM

I HEREBY CERTIFY THAT THIS PLAN WAS PREPARED BY ME OR UNDER MY DIRECT SUPERVISION AND THAT I AM A DULY LICENSED PROFESSIONAL ENGINEER UNDER THE LAWS OF THE STATE OF MINNESOTA.  
 PRINT NAME: Curt Kobilarcsik  
 SIGNATURE: *Curt Kobilarcsik*  
 DATE: 5-23-12    LICENSE NO. 24756

DRAWN BY: BAV    DATE: 3-23-12  
 DESIGN BY: BAV    DATE: 3-23-12  
 CHECKED BY: JEO    DATE: 4-10-12

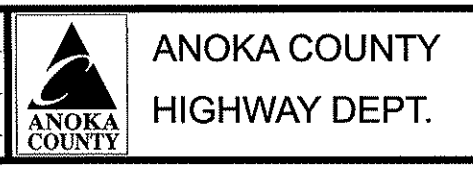

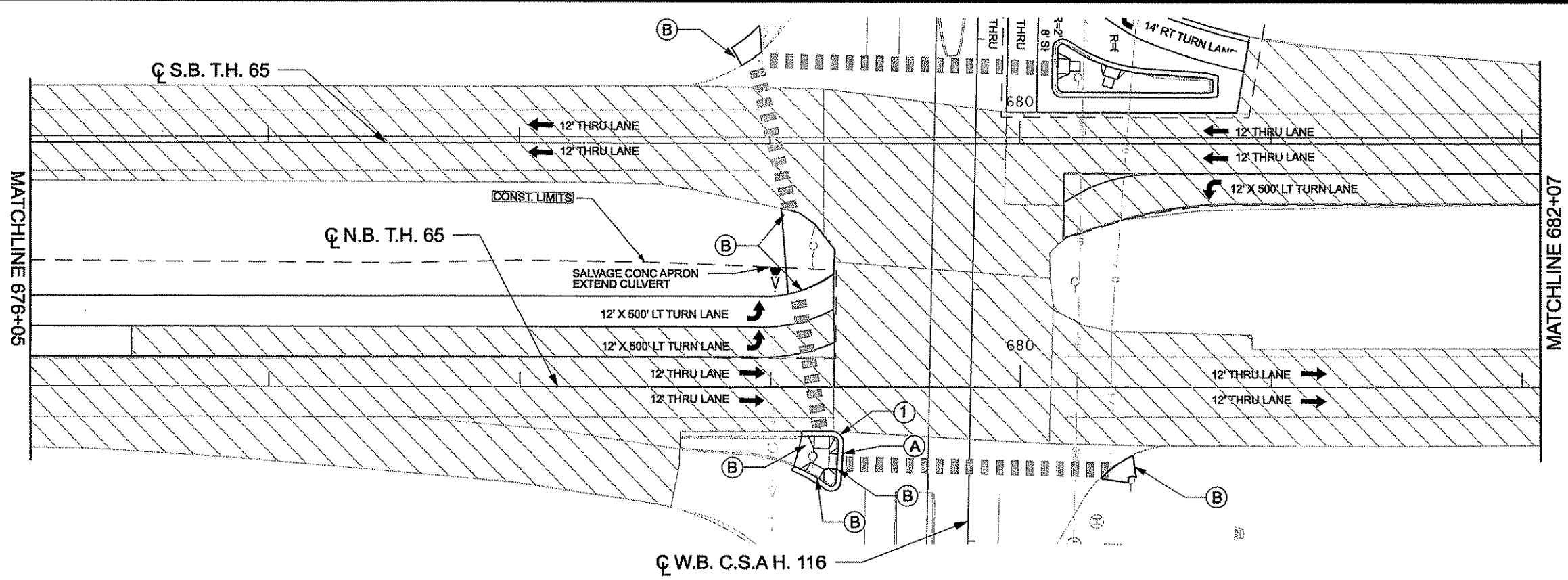

S.P. 0208-145 (T.H. 65)  
 S.A.P. 002-716-013  
 S.A.P. 197-020-004

CONSTRUCTION PLAN & PROFILE  
 STA 670+55 TO 676+05  
 Sheet 50 of 108 Sheets

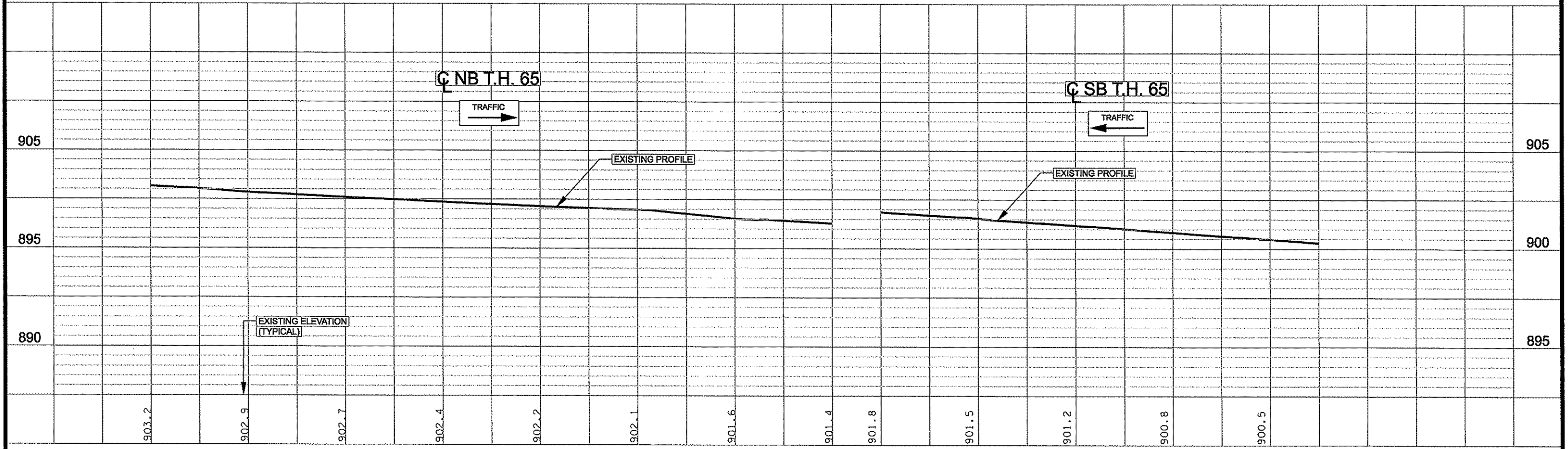
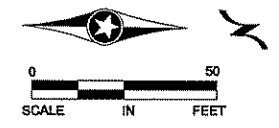

- CONSTRUCTION NOTES:**
- (A) B424 CURB & GUTTER
  - (B) CONCRETE PED RAMP
  - ▨ MILL & OVERLAY
- ALL DIMENSIONS ARE TO FACE OF CURB UNLESS OTHERWISE NOTED.
- (1) STANDARD PLATE 7113 SAFETY NOSE



4 OF 5						
1 NO DATE BY CKD APPR NAME: p:\116-65\plant\116-65_PP_F4.dgn	9/21/12 BAV JEO CAK TEXT UPDATED	I HEREBY CERTIFY THAT THIS PLAN WAS PREPARED BY ME OR UNDER MY DIRECT SUPERVISION AND THAT I AM A DULY LICENSED PROFESSIONAL ENGINEER UNDER THE LAWS OF THE STATE OF MINNESOTA. PRINT NAME: Curt Koblarcaik SIGNATURE: <i>Curt Koblarcaik</i> DATE: 6-27-12 LICENSE NO. 24756	DRAWN BY: BAV DATE: 3-23-12 DESIGN BY: BAV DATE: 3-23-12 CHECKED BY: JEO DATE: 4-10-12	 <p><b>ANOKA COUNTY HIGHWAY DEPT.</b></p>	S.P. 0208-145 (T.H. 65) S.A.P. 002-716-013 S.A.P. 197-020-004	<b>CONSTRUCTION PLAN &amp; PROFILE</b> STA 676+05 TO 682+07 Sheet 51 of 108 Sheets

- CONSTRUCTION NOTES:**
- (A) B424 CURB & GUTTER
  - (B) CONCRETE PED RAMP
  - MILL & OVERLAY
- ALL DIMENSIONS ARE TO FACE OF CURB UNLESS OTHERWISE NOTED.

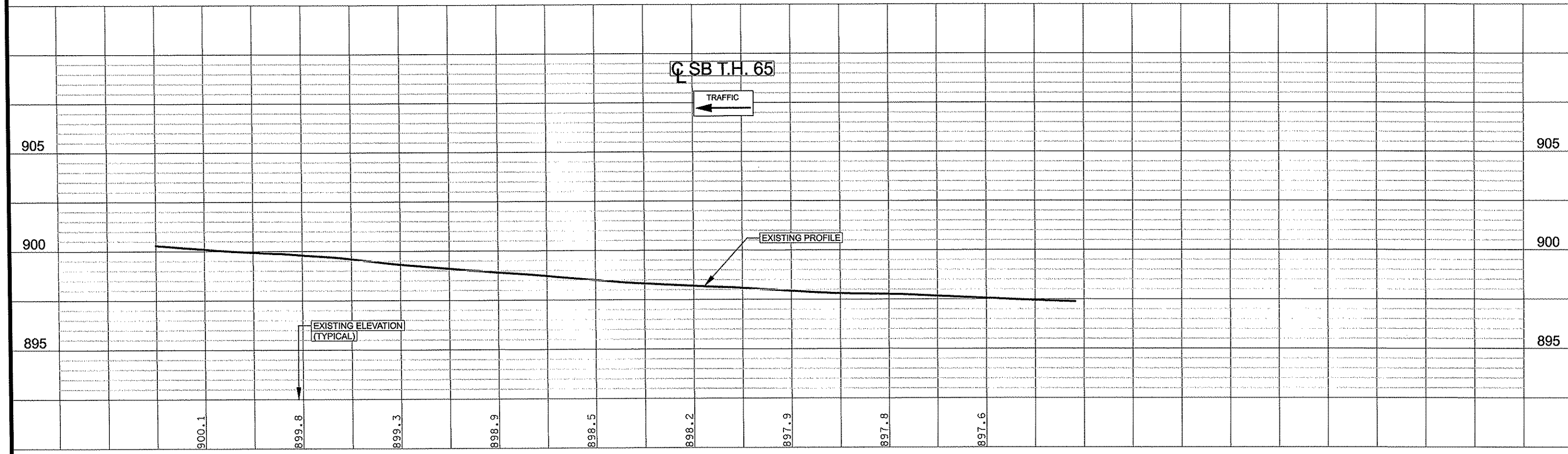
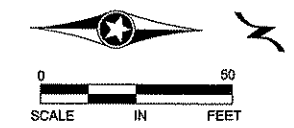
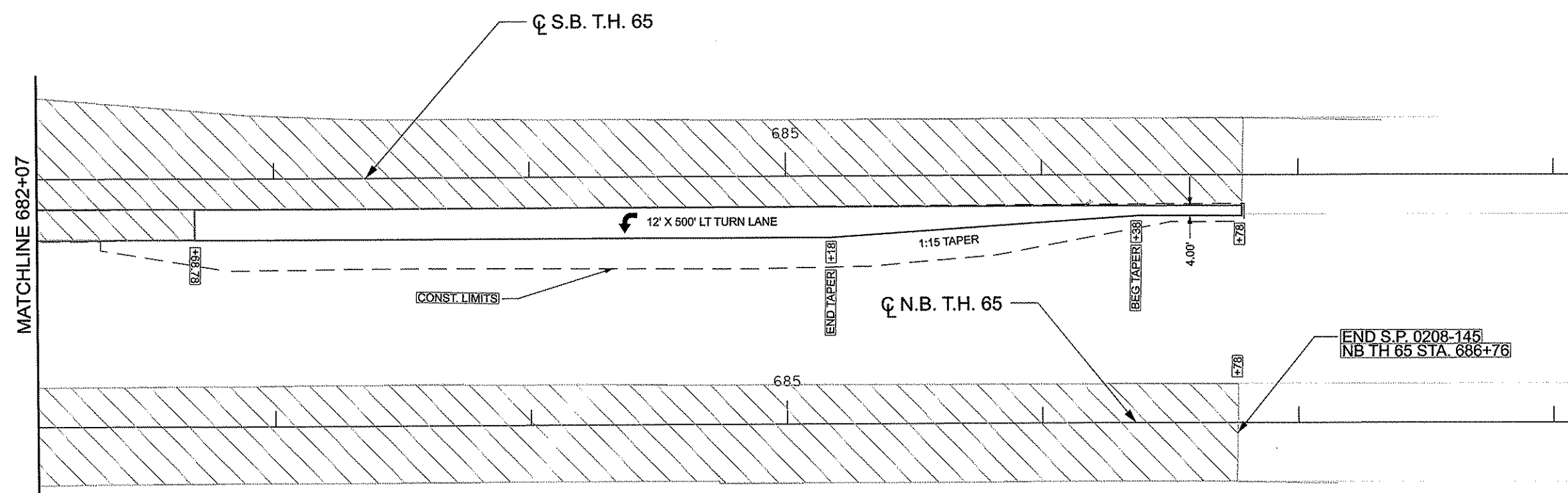

682+25    682+75    683+25    683+75    684+25    684+75    685+25    685+75    686+25    686+75

5 OF 5

1	9/21/12	BAV	JEO	CAK	TEXT UPDATED
NO	DATE	BY	CKD	APPR	REVISION

NAME: p:\116-65\plan\116-65\_PP\_P5.dgn    05/23/2012    9:45:26 AM

I HEREBY CERTIFY THAT THIS PLAN WAS PREPARED BY ME OR UNDER MY DIRECT SUPERVISION AND THAT I AM A DULY LICENSED PROFESSIONAL ENGINEER UNDER THE LAWS OF THE STATE OF MINNESOTA.

PRINT NAME: Curt Kobileresik  
 SIGNATURE: *Curt Kobileresik*  
 DATE: 5-23-12    LICENSE NO. 24756

DRAWN BY: BAV    DATE: 3-23-12  
 DESIGN BY: BAV    DATE: 3-23-12  
 CHECKED BY: JEO    DATE: 4-10-12



S.P. 0208-145 (T.H. 65)  
 S.A.P. 002-716-013  
 S.A.P. 197-020-004

CONSTRUCTION PLAN & PROFILE  
 STA 682+07 TO 686+78  
 Sheet 52 of 108 Sheets

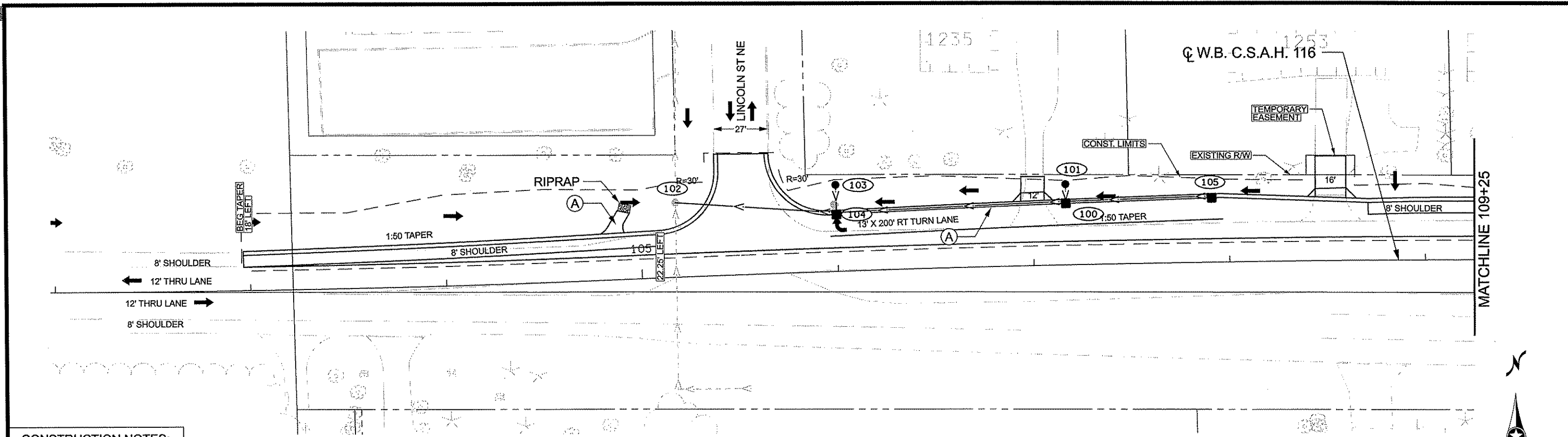

**CONSTRUCTION NOTES:**  
 (A) CONCRETE FLUME  
 ALL DIMENSIONS ARE TO FACE OF CURB UNLESS OTHERWISE NOTED.

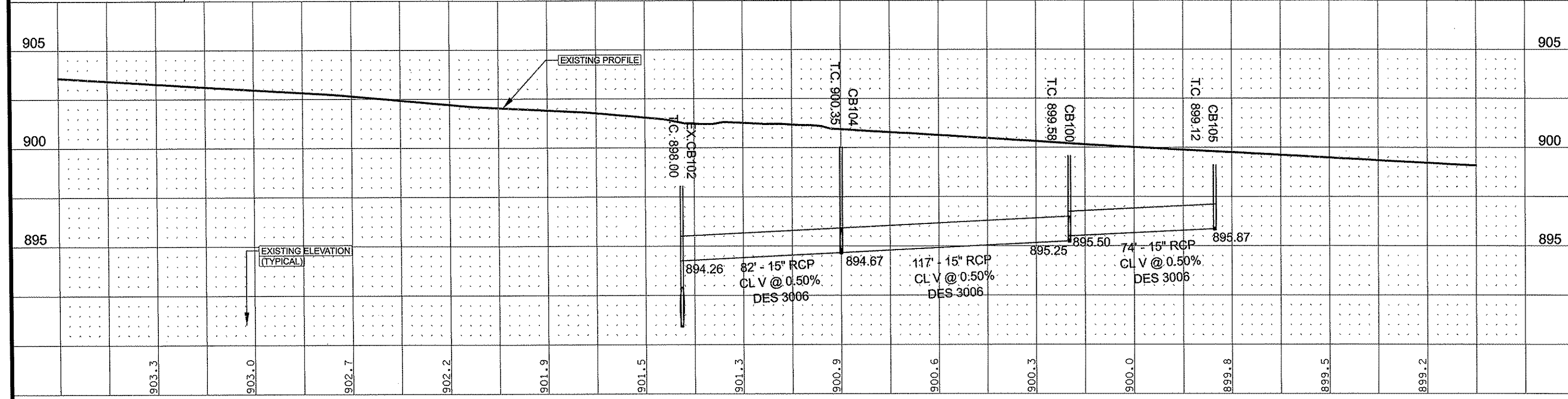
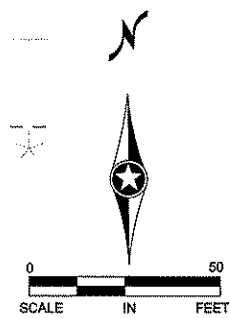

102+00    102+50    103+00    103+50    104+00    104+50    105+00    105+50    106+00    106+50    107+00    107+50    108+00    108+50    109+00    1 OF 3

1	6/21/12	BAV	JEO	CAK	TEXT UPDATED
NO	DATE	BY	CKD	APPR	REVISION
NAME: p:\116-65\plan\116-65_DR_P1.dgn					05/23/2012 9:45:31 AM

I HEREBY CERTIFY THAT THIS PLAN WAS PREPARED BY ME OR UNDER MY DIRECT SUPERVISION AND THAT I AM A DULY LICENSED PROFESSIONAL ENGINEER UNDER THE LAWS OF THE STATE OF MINNESOTA.  
 PRINT NAME: Curt Kobliarscik  
 SIGNATURE: *Curt Kobliarscik*  
 DATE: 5-23-12 LICENSE NO. 24756

DRAWN BY: BAV DATE: 3-23-12  
 DESIGN BY: BAV DATE: 3-23-12  
 CHECKED BY: JEO DATE: 4-10-12

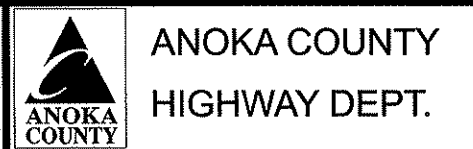

S.P. 0208-145 (T.H. 65)  
 S.A.P. 002-716-013  
 S.A.P. 197-020-004

**DRAINAGE PLAN**  
 STA 102+00.00 TO 109+25.00  
 Sheet 53 of 108 Sheets

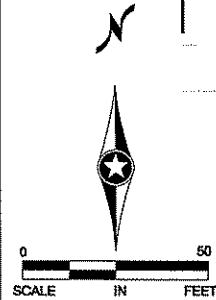
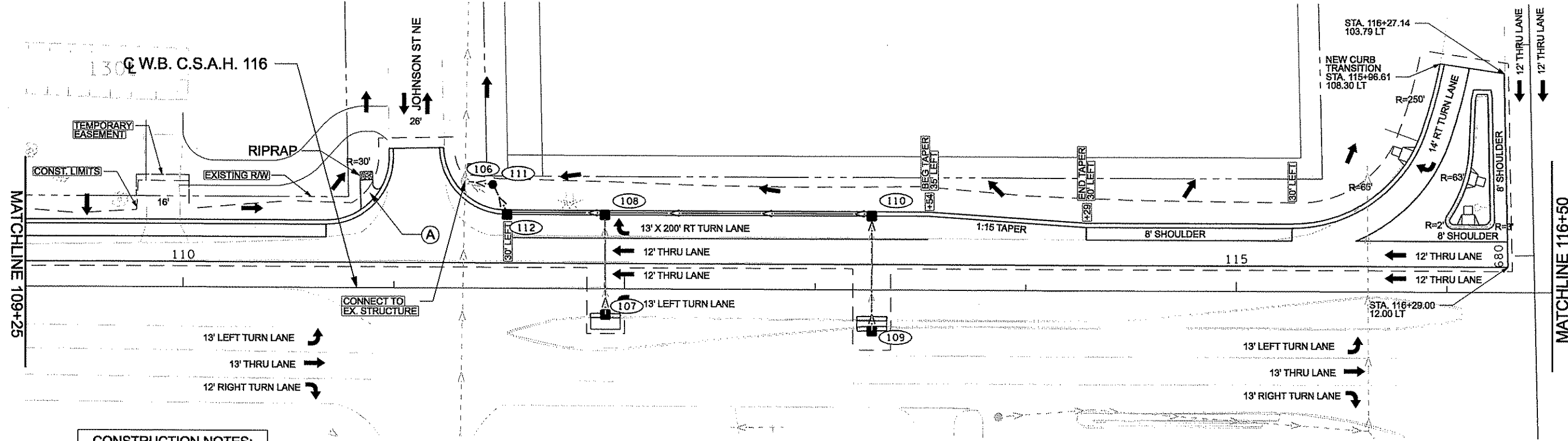

**CONSTRUCTION NOTES:**  
 (A) CONCRETE FLUME  
 ALL DIMENSIONS ARE TO FACE OF CURB UNLESS OTHERWISE NOTED.

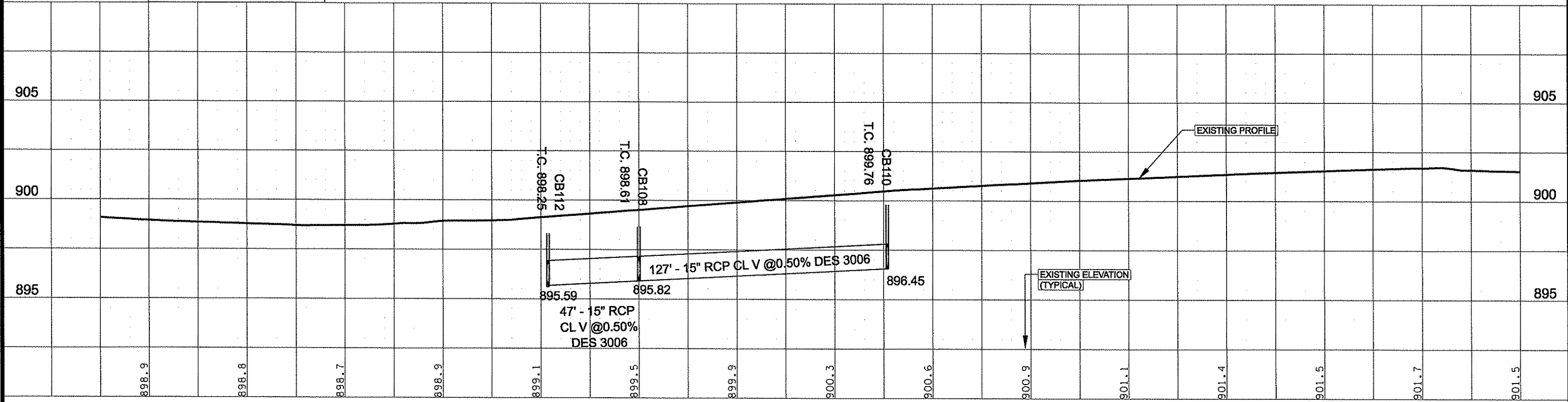

109+50    110+00    110+50    111+00    111+50    112+00    112+50    113+00    113+50    114+00    114+50    115+00    115+50    116+00    116+50

1	5/21/12	BAV	JEO	CAK	TEXT UPDATED
NO	DATE	BY	CKD	APPR	REVISION
NAME: p:\116-65\plan\116-65_DR_P2.dgn    06/26/2012    11:42:40 AM					

I HEREBY CERTIFY THAT THIS PLAN WAS PREPARED BY ME OR UNDER MY DIRECT SUPERVISION AND THAT I AM A DULY LICENSED PROFESSIONAL ENGINEER UNDER THE LAWS OF THE STATE OF MINNESOTA.  
 PRINT NAME: Curt Koblercsik  
 SIGNATURE: *Curt Koblercsik*  
 DATE: 6.27.12    LICENSE NO. 24758

DRAWN BY: BAV    DATE: 3-23-12  
 DESIGN BY: BAV    DATE: 3-23-12  
 CHECKED BY: JEO    DATE: 4-10-12

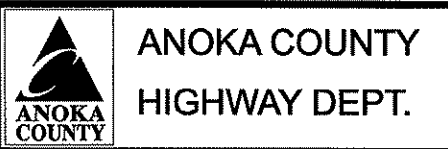

S.P. 0208-145 (T.H. 65)  
 S.A.P. 002-716-013  
 S.A.P. 197-020-004

DRAINAGE PLAN  
 STA 109+25.00 TO 116+50.00  
 Sheet 54 of 108 Sheets

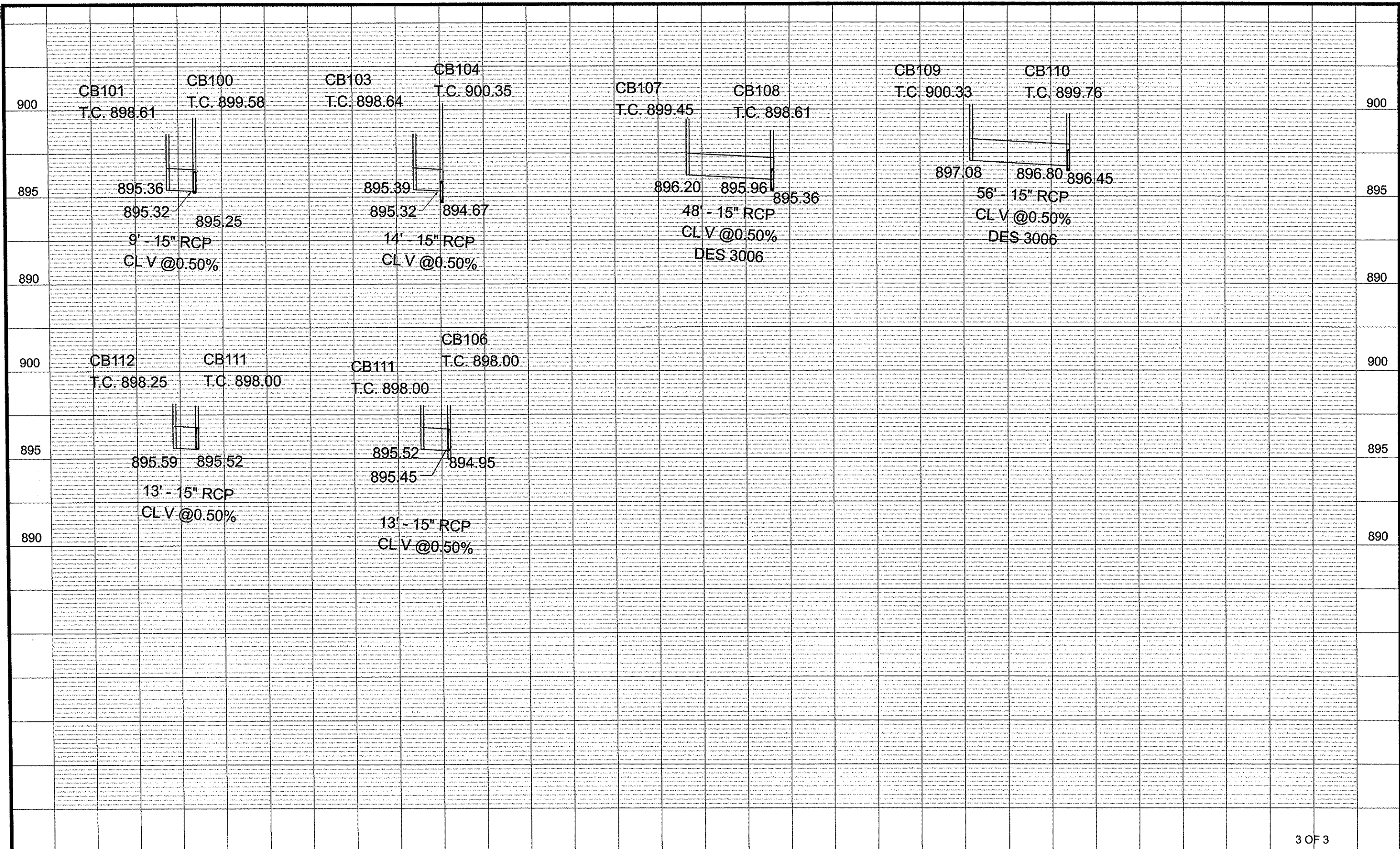

1	5/21/12	BAV	JEO	CAK	TEXT UPDATED
NO	DATE	BY	CKD	APPR	REVISION
NAME: p:\116-65\plan\116-65_DR_P3.dgn					

I HEREBY CERTIFY THAT THIS PLAN WAS PREPARED BY ME OR UNDER MY DIRECT SUPERVISION AND THAT I AM A DULY LICENSED PROFESSIONAL ENGINEER UNDER THE LAWS OF THE STATE OF MINNESOTA.

PRINT NAME: Curt Kobilarosik  
 SIGNATURE: *Curt Kobilarosik*  
 DATE: 5-23-12 LICENSE NO. 24756

DRAWN BY BAV DATE 3-23-12  
 DESIGN BY BAV DATE 3-23-12  
 CHECKED BY JEO DATE 4-10-12

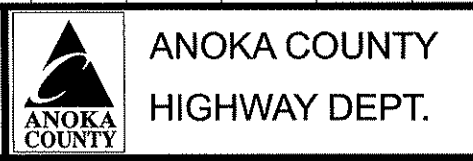

S.P. 0208-145 (T.H. 65)  
 S.A.P. 002-716-013  
 S.A.P. 197-020-004

### LINCOLN ST. NE RADIUS POINTS

POINT	ALIGNMENT	STATION	LOCATION	ELEVATION	DESCRIPTION
U1	WB	105+40.71	53.29' LT	900.65	BEGIN RAD
U2	WB	105+31.29	31.51' LT	900.90	MIDPOINT
U3	WB	105+09.46	22.25' LT	901.14	END RAD
U4	WB	105+08.85	54.90' LT	-	RADIUS POINT
U5	WB	105+64.38	61.45' LT	900.98	BEGIN RAD
U6	WB	105+73.73	38.31' LT	900.74	MIDPOINT
U7	WB	105+96.84	29.00' LT	900.52	END RAD
U8	WB	105+96.20	60.99' LT	-	RADIUS POINT

### LEGEND

999.99 PROPOSED SPOT ELEVATION

----- SAWCUT

PROPOSED CROSS SLOPE ON  
CSAH 116 IS 2.50%

ELEVATIONS ARE TOP OF FINISHED  
PAVEMENT

CURB AND GUTTER ELEVATIONS ARE  
SHOWN AT TOP OF FINISHED BITUMINOUS  
AT LIP OF GUTTER UNLESS OTHERWISE  
NOTED



0 30  
SCALE IN FEET

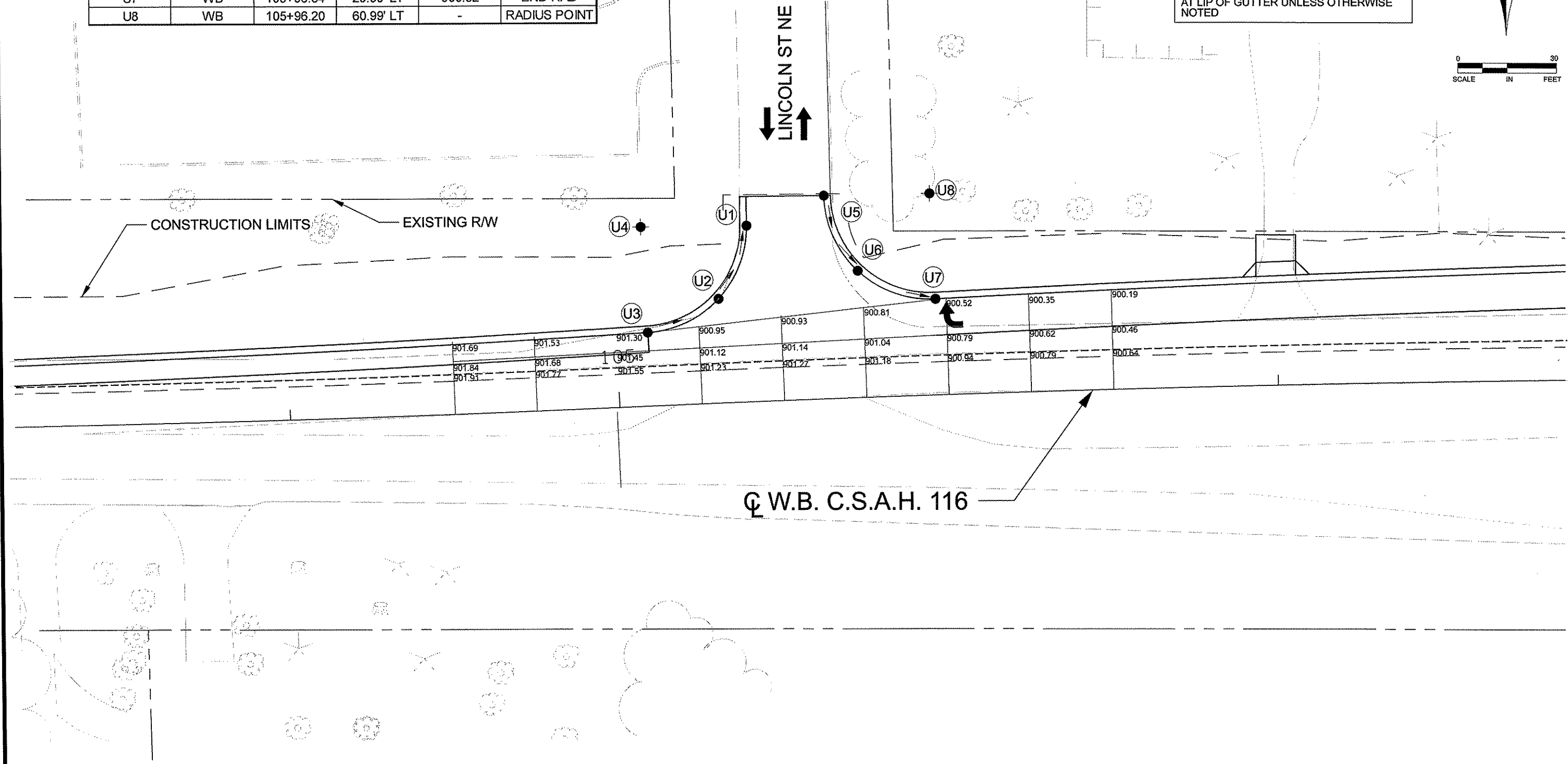

1	5/21/12	BAV	JEO	CAK	TEXT UPDATED
NO	DATE	BY	CKD	APPR	REVISION
NAME: p:\116-65\plan\116-65_IN_1.dgn					05/23/2012
					11:49:12 AM

I HEREBY CERTIFY THAT THIS PLAN WAS PREPARED BY ME OR UNDER MY DIRECT SUPERVISION AND THAT I AM A DULY LICENSED PROFESSIONAL ENGINEER UNDER THE LAWS OF THE STATE OF MINNESOTA.

PRINT NAME: Curt Kobilarcik

SIGNATURE: Curt Kobilarcik

DATE: 5-23-12 LICENSE NO. 24756

DRAWN BY: BAV DATE: 3-23-12

DESIGN BY: BAV DATE: 3-23-12

CHECKED BY: JEO DATE: 4-10-12

**ANOKA COUNTY**  
HIGHWAY DEPT.



S.P. 0208-145 (T.H. 65)  
S.A.P. 002-716-013  
S.A.P. 197-020-004

INTERSECTION DETAILS

Sheet 56 of 108 Sheets



JOHNSON ST. NE RADIUS POINTS					
POINT	ALIGNMENT	STATION	LOCATION	ELEVATION	DESCRIPTION
W1	WB	110+99.66	62.57' LT	899.37	BEGIN RAD
W2	WB	110+90.50	39.58' LT	898.74	MIDPOINT
W3	WB	110+67.67	29.91' LT	898.21	END RAD
W4	WB	110+67.67	62.00' LT	-	RADIUS POINT
W5	WB	110+21.60	66.43' LT	899.10	BEGIN RAD
W6	WB	110+31.17	44.29' LT	898.83	MIDPOINT
W7	WB	110+53.59	35.00' LT	898.50	END RAD
W8	WB	110+53.59	67.00' LT	-	RADIUS POINT

**LEGEND**

999.99 PROPOSED SPOT ELEVATION  
 ---- SAWCUT  
 PROPOSED CROSS SLOPE ON  
 CSAH 116 IS 2.50%  
 ELEVATIONS ARE TOP OF FINISHED  
 PAVEMENT  
 CURB AND GUTTER ELEVATIONS ARE  
 SHOWN AT TOP OF FINISHED BITUMINOUS  
 AT LIP OF GUTTER UNLESS OTHERWISE  
 NOTED

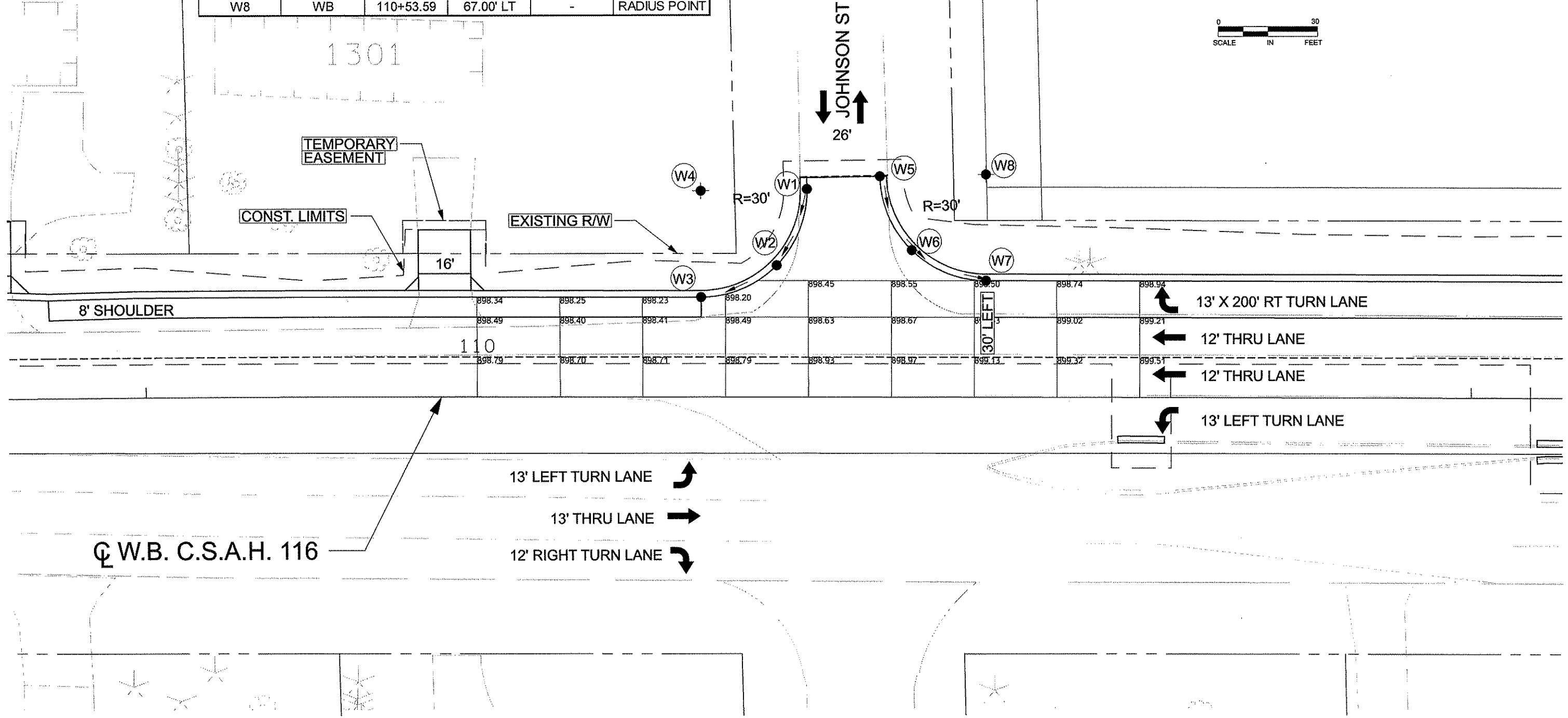
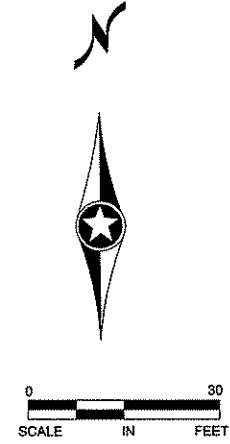

1	5/21/12	BAV	JEO	CAK	TEXT UPDATED
NO	DATE	BY	CKD	APPR	REVISION
NAME: pt116-65\plant116-65_IN_2.dgn					06/23/2012 11:49:16 AM

I HEREBY CERTIFY THAT THIS PLAN WAS PREPARED BY ME OR UNDER MY DIRECT SUPERVISION AND THAT I AM A DULY LICENSED PROFESSIONAL ENGINEER UNDER THE LAWS OF THE STATE OF MINNESOTA.  
 PRINT NAME: Curt Koblarosik  
 SIGNATURE: *Curt Koblarosik*  
 DATE: 5-23-12 LICENSE NO. 24756

DRAWN BY: BAV DATE: 3-23-12  
 DESIGN BY: BAV DATE: 3-23-12  
 CHECKED BY: JEO DATE: 4-10-12



**ANOKA COUNTY  
 HIGHWAY DEPT.**

S.P. 0208-145 (T.H. 65)  
 S.A.P. 002-716-013  
 S.A.P. 197-020-004

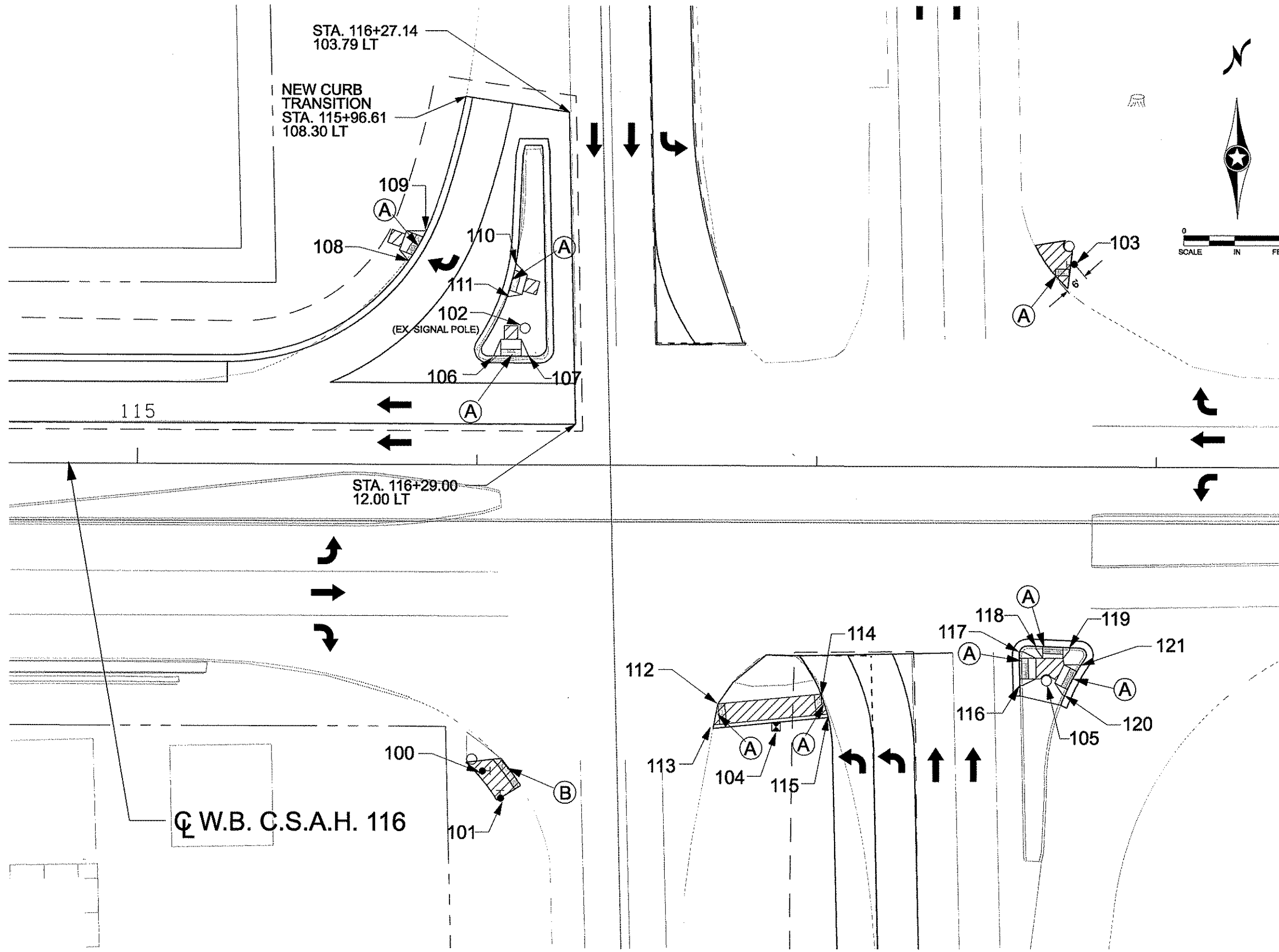

**LEGEND**

- APS PUSH BUTTON
- SIGNAL POLE
- ⊠ PEDESTAL POLE
- Ⓐ RECTANGULAR DETECTABLE WARNING SURFACE
- Ⓑ RADIAL DETECTABLE WARNING SURFACE (60' RADIUS)
- ▨ LANDING AREA - SLOPE SHALL NOT EXCEED 0.020 FT/FT IN ANY DIRECTION
- SEE SHEET 82 FOR ADDITIONAL INFORMATION LOCATING APS PUSH BUTTONS
- ▤ TRUNCATED DOME

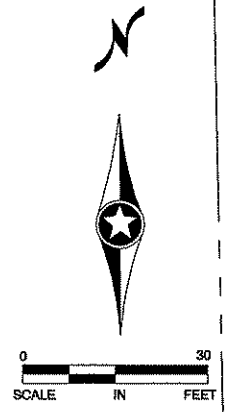

Point	X	Y
100	508182.05	166871.50
101	508187.38	166863.61
102	508194.87	167001.30
103	508356.58	167020.40
104	508268.47	166884.52
105	508348.09	166898.20
106	508185.62	166993.09
107	508195.97	166993.07
108	508160.64	167021.06
109	508165.79	167029.83
110	508192.22	167020.33
111	508189.56	167010.44
112	508251.38	166891.22
113	508250.07	166885.07
114	508281.73	166894.17
115	508283.63	166888.33
116	508340.31	166896.74
117	508340.26	166906.75
118	508344.99	166908.30
119	508354.99	166907.88
120	508353.41	166893.82
121	508358.18	166902.61

NO	DATE	BY	CHKD	APPR	REVISION
1	6/8/12	BAV	JEO	CAK	DETAIL SHEET MODIFIED

NAME: p:\116-65\Plan\116-65\_IN\_3.dgn

I HEREBY CERTIFY THAT THIS PLAN WAS PREPARED BY ME OR UNDER MY DIRECT SUPERVISION AND THAT I AM A DULY LICENSED PROFESSIONAL ENGINEER UNDER THE LAWS OF THE STATE OF MINNESOTA.

PRINT NAME: Curt Koblarcsik  
SIGNATURE: *Curt Koblarcsik*  
DATE: 6-27-12 LICENSE NO. 24768

DRAWN BY: BAV DATE: 3-23-12  
DESIGN BY: BAV DATE: 3-23-12  
CHECKED BY: JEO DATE: 4-10-12

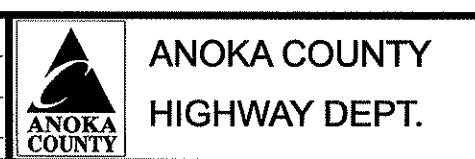

S.P. 0208-145 (T.H. 65)  
S.A.P. 002-716-013  
S.A.P. 197-020-004

INTERSECTION DETAILS  
PED RAMP DETAILS

Sheet 58 of 108 Sheets

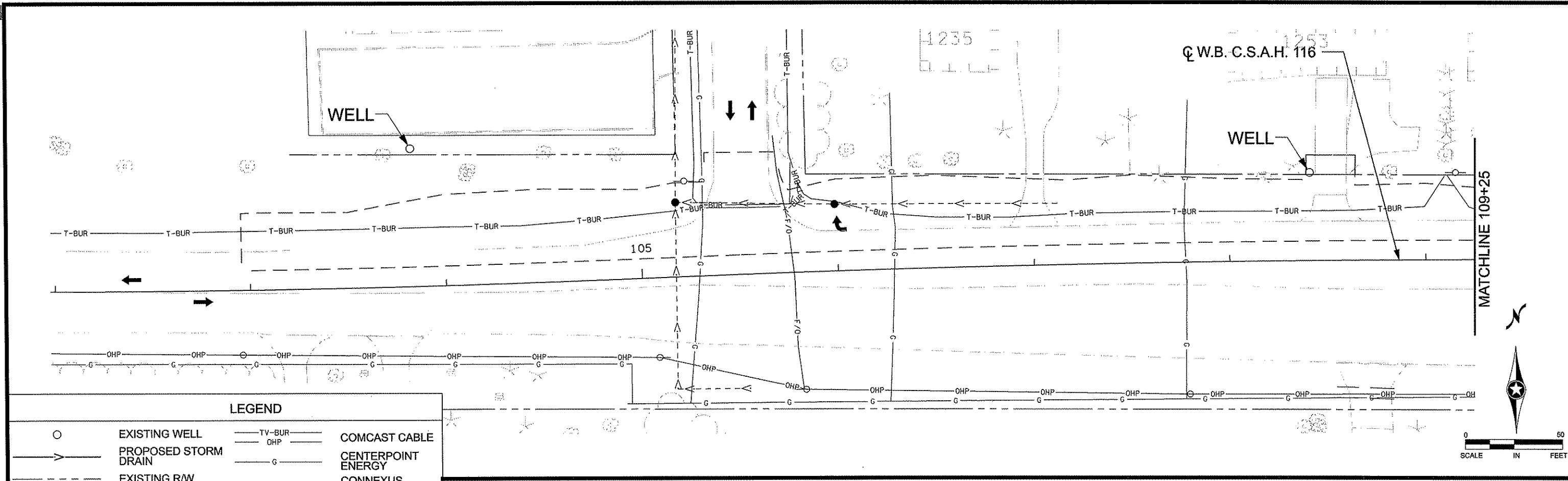

**LEGEND**

○	EXISTING WELL	TV-BUR	COMCAST CABLE
—>	PROPOSED STORM DRAIN	OHP	CENTERPOINT ENERGY
- - -	EXISTING R/W	G	CONNEXUS ENERGY
- - -	CONSTRUCTION LIMITS	OHP	CENTURYLINK (QWEST)
- - ->	EXISTING STORM SEWER	T-BUR	TRAFFIC SIGNAL
- - -	EXISTING CULVERT	F/O	
		SIG-BUR	

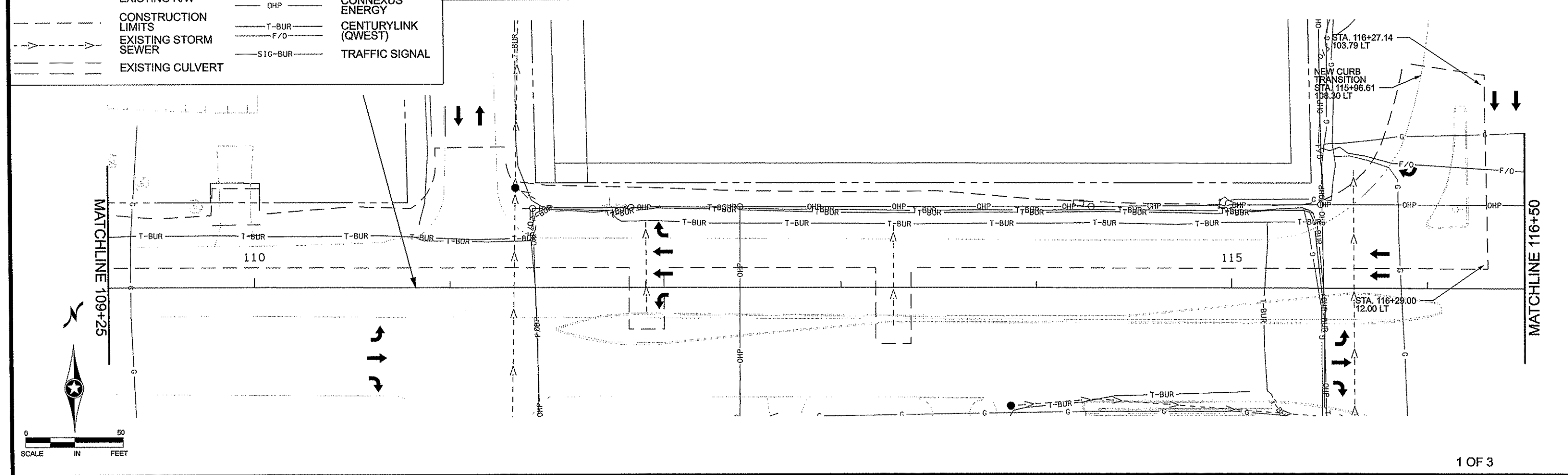

NO	DATE	BY	CKD	APPR	REVISION

NAME: p:\116-65\plan\116-65\_UT\_P1.dgn      05/23/2012      9:45:53 AM

I HEREBY CERTIFY THAT THIS PLAN WAS PREPARED BY ME OR UNDER MY DIRECT SUPERVISION AND THAT I AM A DULY LICENSED PROFESSIONAL ENGINEER UNDER THE LAWS OF THE STATE OF MINNESOTA.

PRINT NAME: Curt Kobilerosik  
 SIGNATURE: *Curt Kobilerosik*  
 DATE: 5-23-12      LICENSE NO. 24756

DRAWN BY: BAV      DATE: 3-23-12  
 DESIGN BY: BAV      DATE: 3-23-12  
 CHECKED BY: JEO      DATE: 4-10-12

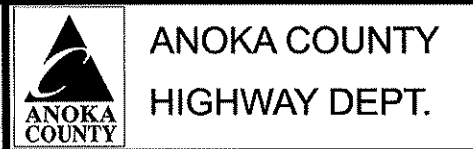

S.P. 0208-145 (T.H. 65)  
 S.A.P. 002-716-013  
 S.A.P. 197-020-004

EXISTING UTILITY PLAN  
 STA 102+00 TO 116+50  
 Sheet 59 of 108 Sheets

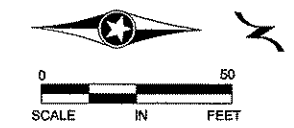
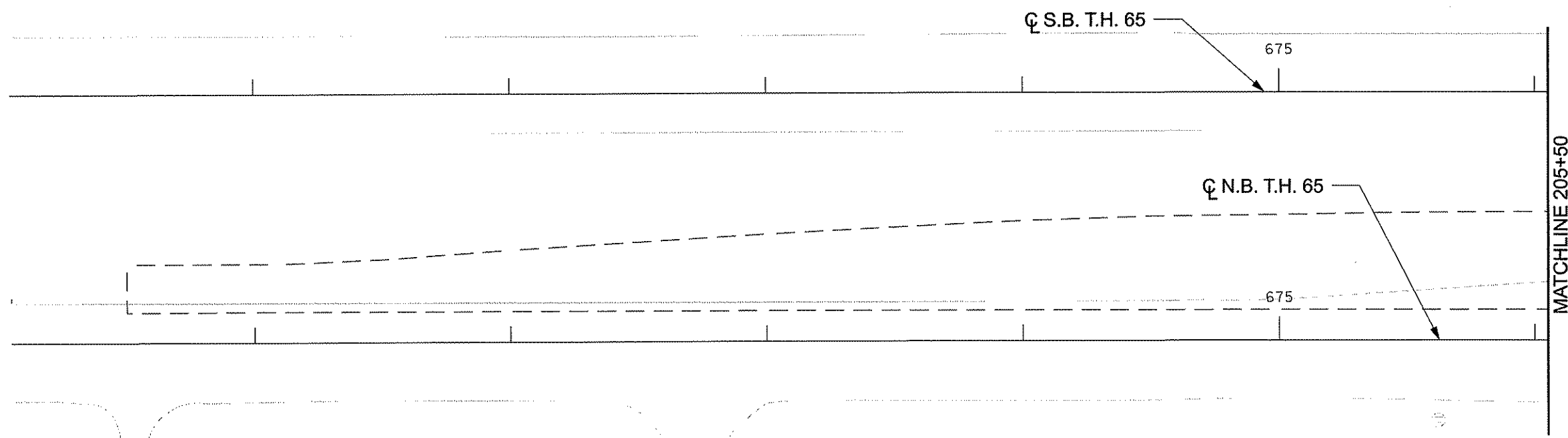

LEGEND			
○	EXISTING WELL	TV-BUR	COMCAST CABLE
—Y—	PROPOSED STORM DRAIN	OHP	CENTERPOINT ENERGY
---	EXISTING R/W	G	CONNEXUS ENERGY
- - -	CONSTRUCTION LIMITS	OHP	CENTURYLINK (QWEST)
- - -Y- - -	EXISTING STORM SEWER	T-BUR	TRAFFIC SIGNAL
---	EXISTING CULVERT	F/O	
		STG-BUR	

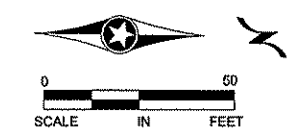
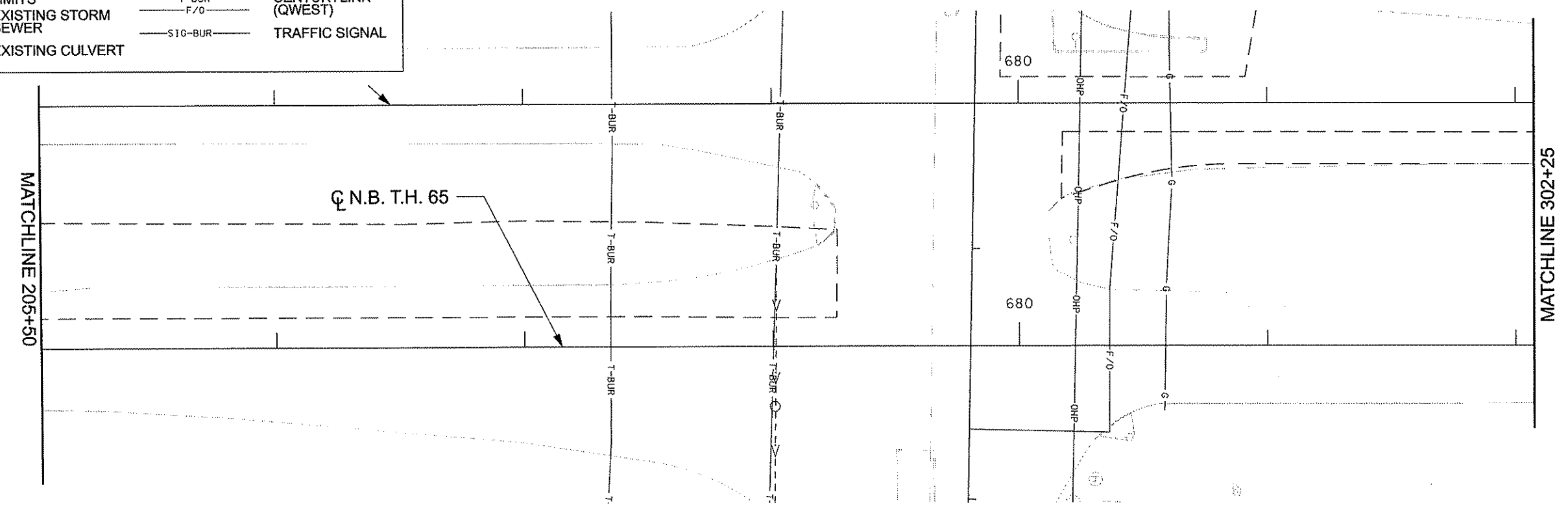

2 OF 3

NO	DATE	BY	CKD	APPR	REVISION

NAME: p:\116-65\plan\116-65\_UT\_P2.dgn      05/23/2012      9:45:55 AM

I HEREBY CERTIFY THAT THIS PLAN WAS PREPARED BY ME OR UNDER MY DIRECT SUPERVISION AND THAT I AM A DULY LICENSED PROFESSIONAL ENGINEER UNDER THE LAWS OF THE STATE OF MINNESOTA.

PRINT NAME: Curt Kobilarcsik  
 SIGNATURE: *Curt Kobilarcsik*  
 DATE: 5-23-12 LICENSE NO. 24756

DRAWN BY BAV DATE 3-23-12  
 DESIGN BY BAV DATE 3-23-12  
 CHECKED BY JEO DATE 4-10-12



S.P. 0208-145 (T.H. 65)  
 S.A.P. 002-716-013  
 S.A.P. 197-020-004

EXISTING UTILITY PLAN  
 STA 200+00 TO 302+25  
 Sheet 60 of 108 Sheets

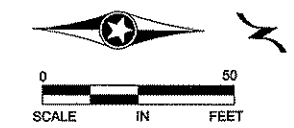
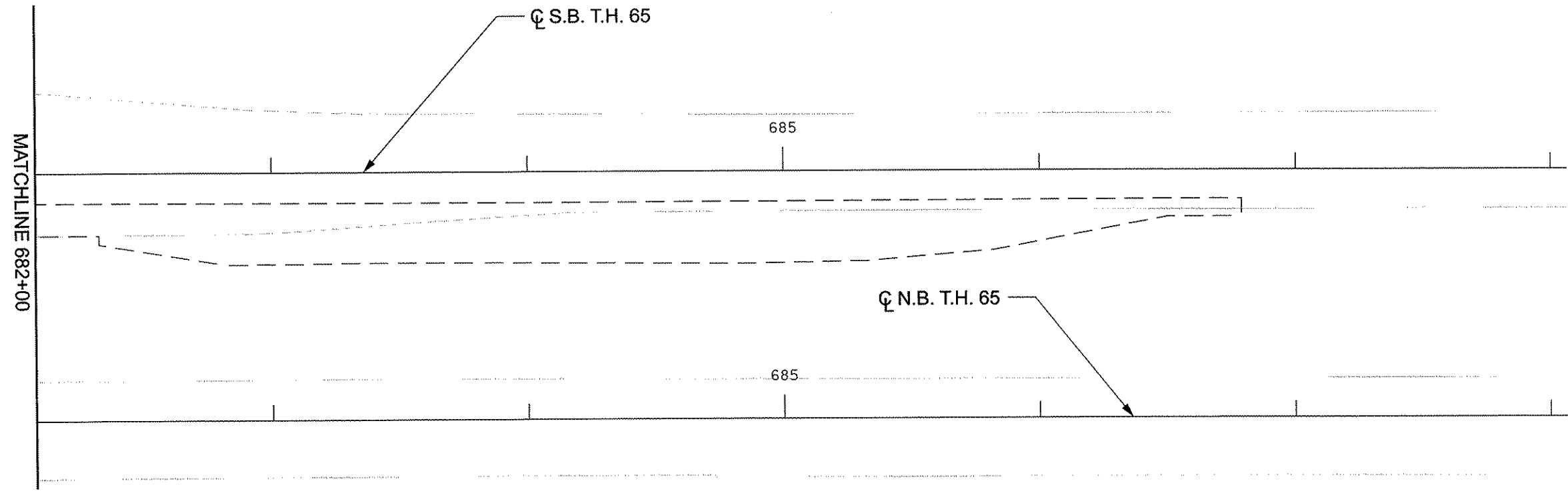

LEGEND			
○	EXISTING WELL	— TV-BUR —	COMCAST CABLE
— > —	PROPOSED STORM DRAIN	— DHP —	CENTERPOINT ENERGY
— — — —	EXISTING R/W	— G —	CONNEXUS ENERGY
— — — —	CONSTRUCTION LIMITS	— OHP —	CENTURYLINK (QWEST)
— > — > —	EXISTING STORM SEWER	— T-BUR —	TRAFFIC SIGNAL
— — — —	EXISTING CULVERT	— F/O —	
		— SIG-BUR —	

NO	DATE	BY	CKD	APPR	REVISION

NAME: p:\116-65\plan\116-65\_UT\_P3.dgn 05/23/2012 9:45:58 AM

I HEREBY CERTIFY THAT THIS PLAN WAS PREPARED BY ME OR UNDER MY DIRECT SUPERVISION AND THAT I AM A DULY LICENSED PROFESSIONAL ENGINEER UNDER THE LAWS OF THE STATE OF MINNESOTA.

PRINT NAME: Curt Kobilarcik

SIGNATURE: *[Signature]*

DATE: 5-23-12 LICENSE NO. 24756

DRAWN BY BAV DATE 3-23-12

DESIGN BY BAV DATE 3-23-12

CHECKED BY JEO DATE 4-10-12



S.P. 0208-145 (T.H. 65)  
S.A.P. 002-716-013  
S.A.P. 197-020-004

EXISTING UTILITY PLAN  
STA 682+00 TO 688+00  
Sheet 61 of 108 Sheets

**PROJECT LOCATION AND GENERAL INFORMATION**

THIS ROAD CONSTRUCTION PROJECT CONSISTS OF EXTENDING THE EXISTING TH 65 LEFT TURN LANES AT CSAH 116, ADDING A SECOND LEFT TURN LANE TO NORTHBOUND TH 65 ONTO WESTBOUND CSAH 116, AND ADDING A SECOND WESTBOUND CSAH 116 RECEIVING LANE. A MILL AND OVERLAY WILL ALSO BE PERFORMED ON TH 65 FOR THE LIMITS OF THE TURN LANE CONSTRUCTION.

THE PROJECT WILL PRIMARILY CONSIST OF GRADING, PLACING OF AGGREGATE BASE, BITUMINOUS PAVING, CURB AND GUTTER, AND MINOR STORM SEWER CONSTRUCTION.

THIS PROJECT WILL REQUIRE THE DISTURBANCE OF 2.1 ACRES OF SOILS AND DOES CREATE THE POTENTIAL FOR SEDIMENT DISCHARGE FROM THE SITE.

**TRAINING REQUIREMENTS**

THE CONTRACTOR WILL ENSURE THAT THE TRAINING REQUIRED IN PART 111.A.2 OF THE GENERAL STORMWATER PERMIT FOR CONSTRUCTION ACTIVITY IS COMPLIED WITH

THE INDIVIDUALS TRAINED AND THE TRAINING RECEIVED WILL BE RECORDED IN THE SWPPP BEFORE THE START OF CONSTRUCTION OR AS SOON AS PERSONELL FOR THE PROJECT HAVE BEEN DETERMINED.

**LONG TERM OPERATION AND MAINTENANCE**

THE CITY OF HAM LAKE STREETS DIVISION WILL BE RESPONSIBLE FOR THE LONG TERM OPERATION AND MAINTENANCE OF THE PERMANENT STORMWATER MANAGEMENT.

TOM REINER  
CITY OF HAM LAKE PUBLIC WORKS SUPERINTENDENT  
1554 CENTRAL AVE NE  
HAM LAKE, MN 55304  
PHONE: (763) 434-9555

**RECEIVING SURFACE WATERS, DISCHARGE TO IMPAIRED WATERS & SPECIAL WATERS**

THE FOLLOWING TABLE BELOW IDENTIFIES ALL SURFACE WATERS WITHIN 1 MILE OF THE DISTURBED SOIL PROJECT BOUNDARIES, WHICH WILL RECEIVE STORMWATER RUNOFF FROM THE CONSTRUCTION SITE, DURING OR AFTER CONSTRUCTION.

STORMWATER FROM A DISCHARGE POINT ON THE PROJECT THAT FLOWS TO A SURFACE WATER IDENTIFIED AS IMPAIRED AND/OR SPECIAL MUST INCLUDE THE FOLLOWING ADDITIONAL BMP REQUIREMENTS:

- 1) ALL EXPOSED SOIL AREAS MUST BE STABILIZED AS SOON AS POSSIBLE TO LIMIT SOIL EROSION BUT IN NO CASE LATER THEN SEVEN (7) DAYS AFTER THE CONSTRUCTION ACTIVITY IN THAT PORTION OF THE SITE HAS TEMPORARILY OR PERMANENTLY CEASED.
- 2) TEMPORARY SEDIMENT BASINS MUST BE USED FOR COMMON DRAINAGE LOCATIONS THAT SERVE AN AREA WITH FIVE (5) OR MORE ACRES DISTURBED AT ONE TIME. THIS PROJECT AS DESIGNED DOES NOT HAVE FIVE (5) DISTURBED ACRES DRAINING TO A COMMON LOCATION AND TEMPORARY SEDIMENT BASINS WILL NOT BE REQUIRED.

RECEIVING SURFACE WATERS		
NAME OF WATER BODY	SPECIAL WATER	IMPAIRED WATER
ANOKA COUNTY		
COON CREEK	NO	YES

**DISTURBED SOIL AREA**

TOTAL DISTURBED SOILS AREA FOR THIS PROJECT IS 2.1 ACRES

**IMPERVIOUS SOIL AREA**

EXISTING AREA OF IMPERVIOUS SURFACE IS 0.84 ACRES.  
POST CONSTRUCTION AREA OF IMPERVIOUS SURFACE 1.25 ACRES.

**SOIL TYPES**

THE PREDOMINANT SOIL TYPE FOUND ON THIS PROJECT IS SAND.

**CONSTRUCTION PHASING**

SILT FENCE AND/OR OTHER SUITABLE PERIMETER BMP'S AS PROVIDED IN THE PLANS WILL BE INSTALLED PRIOR TO THE START OF ANY LAND DISTURBING ACTIVITY. CONSTRUCTION WILL BE REQUIRED TO BE PHASED SO THAT ALL DOWN GRADIENT SEDIMENT CONTROL MEASURES ARE INSTALLED PRIOR TO OR IN CONJUNCTION WITH ANY SOIL DISTURBING ACTIVITIES.

WHEN TOPSOIL IS DISTURBED, THE TOPSOIL WILL BE STRIPPED AND STOCKPILED IN SOIL BERMS AT THE TOE OF THE STRIPPED SLOPES ALONG THE PROJECT LIMITS. TEMPORARY VEGETATION WILL BE ESTABLISHED ON THE STOCKPILED TOPSOIL BERMS WITH HYDROMULCH AS NEEDED. STOCKPILED TOPSOIL BERMS WILL NOT BE PLACED IN ANY STORMWATER CONVEYANCES.

AFTER STRIPING THE TOPSOIL THE EXPOSED SOIL INSLOPES WILL BE STABILIZED WITH DISK ANCHORED TYPE 1 MULCH WITHIN 14 DAYS AFTER THE CONSTRUCTION ACTIVITY IN THAT PORTION OF THE SITE HAS BEEN TEMPORARILY OR PERMANENTLY CEASED.

**TEMPORARY SEDIMENT BASINS**

THIS ROAD CONSTRUCTION PROJECT AS DESIGNED DOES NOT MEET ANY OF THE TEMPORARY SEDIMENT BASIN DISTURBED AREA THRESHOLD REQUIREMENTS AND TEMPORARY SEDIMENT BASINS WILL NOT BE REQUIRED.

**PERMANENT STORMWATER MANAGEMENT SYSTEM**

ALL STORMWATER MUST BE DISCHARGED IN A MANNER THAT DOES NOT CAUSE NUISANCE CONDITIONS, EROSION IN RECEIVING WATERS OR ON DOWNSLOPE PROPERTIES, OR INUNDATION IN WETLANDS CAUSING A SIGNIFICANT ADVERSE IMPACT TO THE WETLAND.

THIS ROAD CONSTRUCTION PROJECT HAS A LESS THEN 1 ACRE INCREASE IN IMPERVIOUS AREA.

**EROSION PREVENTION PRACTICES**

ALL EXPOSED SOIL AREAS MUST BE STABILIZED AS SOON AS POSSIBLE TO LIMIT SOIL EROSION BUT IN NO CASE LATER THEN 14 DAYS AFTER THE CONSTRUCTION ACTIVITY IN THAT PORTION OF THE SITE HAS TEMPORARILY OR PERMANENTLY CEASED. FOR ALL AREAS WHERE DISTURBED SOILS DRAIN TO AN IMPAIRED OR SPECIAL WATER THE EXPOSED SOIL MUST BE STABILIZED NO LATER THEN 7 DAYS AFTER THE CONSTRUCTION ACTIVITY IN THAT AREA CEASED. SEE THE IMPAIRED & SPECIAL WATERS SECTION OF THIS SWPPP FOR ADDITIONAL BMP REQUIREMENTS FOR DISTURBED AREAS THAT DRAIN TO A SPECIAL OR IMPAIRED WATER

THE NORMAL WETTED PERIMETER OF ANY TEMPORARY OR PERMANENT DRAINAGE DITCH OR SWALE THAT DRAIN WATER FROM ANY PORTION OF THE CONSTRUCTION SITE, OR DIVERTS WATER AROUND THE SITE, MUST BE STABILIZED WITHIN 200 LINEAL FEET FROM THE POINT OF DISCHARGE INTO ANY SURFACE WATER. STABILIZATION OF THE LAST 200 FEET MUST BE COMPLETED WITHIN 24 HOURS AFTER CONNECTING TO A SURFACE WATER.

PIPE CULVERT OUTLETS MUST BE PROVIDED WITH TEMPORARY OR PERMANENT ENERGY DISSIPATION WITHIN 24 HOURS AFTER CONNECTION TO A SURFACE WATER. THIS WILL INCLUDE DRAINAGE DITCHES THAT DRAIN WATER FROM ANY PORTION OF THE CONSTRUCTION SITE

**PROJECT CONTACTS**

MPCA	NPDES	LAURAL MEZNER	218-316-3889
MPCA	EMERGENCY	STATE DUTY OFFICER	800-422-0798
DNR	NOT REQUIRED		
COE	NOT REQUIRED		
ANOKA COUNTY DESIGN SWPPP PREPARATION	U OF MN DESIGN OF SWPPP EXPIRES 5/13	BRETT VOTH	763-862-4263
ANOKA COUNTY PROJECT REPRESENTATIVE	U OF MN SITE MANAGEMENT EXPIRES 5/12	CHRIS OSTERHUS	763-862-4252
EROSION CONTROL SUPERVISOR (CONTRACTOR)			

**SEDIMENT CONTROL PRACTICES**

TEMPORARY STOCKPILED TOPSOIL BERMS MUST INCLUDE PERIMETER BMP'S (SILT FENCE AND BERM) AT LOCATIONS WHERE CONSTRUCTION STORMWATER DRAINS FROM THE PROJECT

IN ORDER TO MAINTAIN SHEET FLOW AND MINIMIZE RILLS AND/OR GULLIES, THERE SHALL BE NO UNBROKEN SLOPE LENGTH OF GRATER THEN 75 FEET FOR SLOPES WITH A GRADE OF 1:3 OR STEEPER

ALL STORM DRAIN INLETS MUST BE PROTECTED BY APPROPRIATE BMP'S DURING CONSTRUCTION UNTIL ALL SOURCES WITH POTENTIAL DISCHARGE TO THE INLET HAVE BEEN STABILIZED

VEHICLE TRACKING OF SEDIMENT FROM THE CONSTRUCTION SITE MUST BE MINIMIZED. STREET SWEEPING MUST BE USED IF SEDIMENT IS BEING TRACKED OFF THE CONSTRUCTION SITE

**POLLUTION PROVENTION MEASURES**

THE CONTRACTOR WILL IMPLEMENT THE POLLUTION PREVENTION MANAGEMENT MEASURES AS DIRECTED IN THE NPDES PERMIT PART IV.F AS PERTAINING TO SOLID WASTE, HAZARDOUS MATERIALS EXTERNAL TRUCK WASHING, AND CONCRETE WASHOUT ONSITE.

THESE MANAGEMENT MEASURES FOR POLLUTION PREVENTION WILL BE STRICTLY ENFORCED.

**LOCATION OF SWPPP REQUIREMENTS**

REQUIREMENT	PLAN		MN/DOT SPECIFICATION	SPECIAL PROVISION
	TITLE	LOCATION		
NPDES PERMIT COMPLIANCE			1701, 1702, & 1717	1717 (AIR, LAND & WATER) 1717 (NATIONAL POLLUTANT DISCHARGE ELIMINATION SYSTEM (NPDES) PERMIT)
CERTIFIED PERSONNEL IN EROSION AND SEDIMENT CONTROL SITE MANAGEMENT			1506, 1717, & 2573	1717 (AIR, LAND & WATER) 1717 (NATIONAL POLLUTANT DISCHARGE ELIMINATION SYSTEM (NPDES) PERMIT)
CHAIN OF RESPONSIBILITY	AGENCY CONTACTS		1506, 1717, & 2573	
PROJECT SCHEDULE / WEEKLY EROSION & SEDIMENT CONTROL SCHEDULE / COMPLETING INSPECTION / MAINTENANCE LOG	AGENCY CONTACTS		1717 & 2573	1717 (AIR, LAND & WATER) 1717 (NATIONAL POLLUTANT DISCHARGE ELIMINATION SYSTEM (NPDES) PERMIT)
SWPPP PREPARATION	AGENCY CONTACTS			
SITE MAP / RECEIVING WATERS / DIRECTION OF FLOW			1717	
PROJECT SPECIFIC CONSTRUCTION STAGING			1717	1717 (AIR, LAND & WATER) 1717 (NATIONAL POLLUTANT DISCHARGE ELIMINATION SYSTEM (NPDES) PERMIT) 1806 (DETERMINATION AND EXTENSION OF CONTRACT TIME)
TEMPORARY EROSION AND SEDIMENT CONTROL BMP LOCATIONS, INSTALLATION, TIMING OF INSTALLATION AND TYPE OF BMP	QUANTITY TABULATIONS		2573 & 2525	2575 (RAPID STABILIZATION SPECIFICATION)
ADDITIONAL TEMPORARY AND OR PERMANENT EROSION AND SEDIMENT CONTROL BMP'S NOT PROVIDED OR SHOWN IN THE PLAN			1717, 2573, & 2575	1717 (AIR, LAND & WATER) 1717 (NATIONAL POLLUTANT DISCHARGE ELIMINATION SYSTEM (NPDES) PERMIT) 2575 (RAPID STABILIZATION SPECIFICATION)
MAINTENANCE OF EROSION AND SEDIMENT CONTROL DEVICES, REMOVAL OF TRACKED SEDIMENT, REMOVAL OF DEVICES			1717 & 2573	1514 (MAINTENANCE DURING CONSTRUCTION) 1717 (LAND AIR & WATER) 1717 (NATIONAL POLLUTANT DISCHARGE ELIMINATION SYSTEM (NPDES) PERMIT)
DEWATERING			2106.3B, & 2451.3C	DEWATERING MAY ALSO REQUIRE DNR PERMIT. NO DEWATERING IS ANTICIPATED FOR THIS PROJECT
FINAL STABILIZATION	QUANTITY TABULATIONS EROSION CONTROL PLAN		1717, 2573, & 2575	1717 (AIR, LAND & WATER) 1717 (NATIONAL POLLUTANT DISCHARGE ELIMINATION SYSTEM (NPDES) PERMIT)
TEMPORARY EROSION AND SEDIMENT CONTROL DETAILS	QUANTITY TABULATIONS EROSION CONTROL PLAN		2575	2575 (RAPID STABILIZATION SPECIFICATION)
PERMANENT EROSION CONTROL DETAILS	EROSION CONTROL DETAILS		2575	2575 (CONTROLLING EROSION AND ESTABLISHING VEGETATION)

NO	DATE	BY	CHKD	APPR	REVISION

NAME: P:\116-65\Plan\116-65\_SWPPP.dgn 05/23/2012 1:57:22 PM

I HEREBY CERTIFY THAT THIS PLAN WAS PREPARED BY ME OR UNDER MY DIRECT SUPERVISION AND THAT I AM A DULY LICENSED PROFESSIONAL ENGINEER UNDER THE LAWS OF THE STATE OF MINNESOTA.  
PRINT NAME: Curt Koblarscik  
SIGNATURE: *Curt Koblarscik*  
DATE: \_\_\_\_\_ LICENSE NO. 24756

DRAWN BY: BAV DATE: 3-23-12  
DESIGN BY: BAV DATE: 3-23-12  
CHECKED BY: JEO DATE: 4-10-12

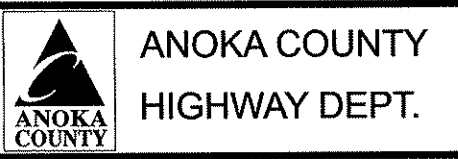

S.P. 0208-145 (T.H. 65)  
S.A.P. 002-716-013  
S.A.P. 197-020-004

STORM WATER POLLUTION PREVENTION PLAN (SWPPP)  
Sheet 62 of 108 Sheets

**STORM WATER POLLUTION PREVENTION PLAN (SWPPP)**

**Training |**

Individual revising or amending the SWPPP and individuals performing inspections must fill in the following table.

<b>Name of on-site personnel trained</b>	
<b>Dates of training</b>	
<b>Name of instructor(s)</b>	
<b>Entity providing training</b>	
<b>Content of training course or workshop</b>	

**Amending the SWPPP**

The SWPPP must be amended to record changes or modifications to permanent BMP's or other storm water treatment systems and removals of temporary BMP's. Changes to temporary BMP's may be recorded on this sheet. Include a brief description of the problem, location, nature of alteration, and comments. This record is to be retained for three years after project completion.

Date Reported	Plan Location (sheet)	Project Location (station)	Problem, solution, and notes

NO	DATE	BY	CKD	APPR	REVISION
NAME: p:\116-65\Plant116-65_SWPPP.dgn					05/23/2012 9:46:01 AM

I HEREBY CERTIFY THAT THIS PLAN WAS PREPARED BY ME OR UNDER MY DIRECT SUPERVISION AND THAT I AM A DULY LICENSED PROFESSIONAL ENGINEER UNDER THE LAWS OF THE STATE OF MINNESOTA.  
 PRINT NAME: Curt Kobilarcsik  
 SIGNATURE: *[Signature]*  
 DATE: 5-23-12 LICENSE NO. 24756

DRAWN BY: BAV DATE: 3-23-12  
 DESIGN BY: BAV DATE: 3-23-12  
 CHECKED BY: JEO DATE: 4-10-12



**ANOKE COUNTY  
HIGHWAY DEPT.**

S.P. 0208-145 (T.H. 65)  
 S.A.P. 002-716-013  
 S.A.P. 197-020-004

**STORM WATER POLLUTION  
PREVENTION PLAN (SWPPP)**

Sheet 63 of 108 Sheets

**PERMANENT PAVEMENT MARKING PLAN**  
NOTES AND GUIDELINES

**GENERAL INFORMATION:**

THE ENGINEER'S INVOLVEMENT IN THE APPLICATION OF THE MATERIAL SHALL BE LIMITED TO FIELD CONSULTATION AND INSPECTION. ANOKA COUNTY HIGHWAY DEPARTMENT WILL PLACE NECESSARY "SPOTTING" AT APPROPRIATE POINTS TO PROVIDE HORIZONTAL CONTROL FOR STRIPING AND TO DETERMINE NECESSARY STARTING AND CUTOFF POINTS, LONGITUDINAL JOINTS, PAVEMENT EDGES AND EXISTING MARKINGS MAY SERVE AS HORIZONTAL CONTROL WHEN SO DIRECTED.

EDGE LINES AND LANE LINES ARE TO BE BROKEN ONLY AT INTERSECTIONS WITH PUBLIC ROADS AND AT PRIVATE ENTRANCES IF THEY ARE CONTROLLED BY A YIELD SIGN, STOP SIGN OR TRAFFIC SIGNAL. THE BREAK POINT IS TO BE AT THE START OF THE RADIUS FOR THE INTERSECTION OR AT MARKED STOP LINES OR CROSSWALKS.

A TOLERANCE OF 1/4 INCH UNDER OR 1/4 INCH OVER THE SPECIFIED WIDTH WILL BE ALLOWED FOR STRIPING PROVIDED THE VARIATION IS GRADUAL AND DOES NOT DETRACT FROM THE GENERAL APPEARANCE. BROKEN LINE SEGMENTS MAY VARY UP TO ONE-HALF FOOT FROM THE SPECIFIED LENGTHS PROVIDED THE OVER AND UNDER VARIATIONS ARE REASONABLY COMPENSATORY. ALIGNMENT DEVIATIONS FROM THE CONTROL GUIDE SHALL NOT EXCEED 1 INCH. MATERIAL SHALL NOT BE APPLIED OVER LONGITUDINAL JOINTS, ESTABLISHMENT OF APPLICATION TOLERANCES SHALL NOT RELIEVE THE CONTRACTOR OF THEIR RESPONSIBILITY TO COMPLY AS CLOSELY AS PRACTICABLE WITH THE PLANNED DIMENSIONS.

**EPOXY:**

THE ROAD SURFACE SHALL BE CLEANED AT THE DIRECTION OF THE ENGINEER JUST PRIOR TO APPLICATION. PAVEMENT CLEANING SHALL CONSIST OF AT LEAST BRUSHING WITH A ROTARY BROOM (NON-METALLIC) OR AS RECOMMENDED BY THE MATERIAL MANUFACTURER AND ACCEPTABLE TO THE ENGINEER. NEW PORTLAND CEMENT CONCRETE SURFACES SHALL BE SANDBLAST CLEANED TO REMOVE ANY SURFACE TREATMENT AND/OR LAITANCE ON LOW SPEED (SPEED LIMIT 35 MPH OR LESS) URBAN PORTLAND CEMENT CONCRETE ROADWAYS. SANDBLAST CLEANING SHALL BE USED FOR ALL EPOXY PAVEMENT MARKINGS.

THE EPOXY MARKING APPLICATION SHALL IMMEDIATELY FOLLOW THE PAVEMENT CLEANING. GLASS BEANS SHALL BE APPLIED IMMEDIATELY AFTER APPLICATION OF THE EPOXY RESIN LINE TO PROVIDE AN IMMEDIATE NO-TRACK SYSTEM.

AN EPOXY RESIN LINE 4" WIDE AND 15 MILL THICKNESS (WET), REQUIRES AN APPLICATION RATE OF ONE (1) GALLON OF COMPONENTS FOR 320 FEET OF LINE. GLASS BEANS SHALL BE APPLIED AT A POUND PER GALLON RATE SUFFICIENT TO ACHIEVE AN ACCEPTABLE NO-TRACK SYSTEM.

OPERATIONS SHALL BE CONDUCTED ONLY WHEN THE ROAD PAVEMENT SURFACE TEMPERATURES ARE 50 DEGREES FAHRENHEIT OR GREATER.

PERMANENT PAVEMENT MARKINGS SHALL NOT BE PLACED OVER TEMPORARY TAPE MARKINGS.

**PREFORMED THERMOPLASTIC:**

THE PREFORMED THERMOPLASTIC MARKINGS SHALL BE APPLIED IN ACCORDANCE WITH THE MANUFACTURER'S RECOMMENDATIONS ON CLEAN AND DRY SURFACES. SEE SPECIAL PROVISIONS FOR PREFORMED THERMOPLASTIC MARKING SPECIFICATIONS.

**PAINT:**

AT THE TIME OF APPLYING THE MARKING MATERIAL, THE APPLICATION AREA SHALL BE FREE OF CONTAMINATION. THE CONTRACTOR SHALL CLEAN THE ROADWAY SURFACE PRIOR TO THE LINE APPLICATION IN A MANNER AND TO THE EXTENT REQUIRED BY THE ENGINEER.

GLASS BEADS SHALL BE APPLIED IMMEDIATELY AFTER APPLICATION OF THE PAINT LINE.

EXCEPT WHEN USED AS A TEMPORARY MARKING, PAVEMENT MARKINGS SHALL ONLY BE APPLIED IN SEASONABLE WEATHER WHEN AIR TEMPERATURE IS 50 DEGREES FARHENHEIT OR HIGHER AND SHALL NOT BE APPLIED WHEN THE WIND OR OTHER CONDITIONS CAUSE A FILD OR DUST TO BE DEPOSITED ON THE PAVEMENT SURFACE AFTER CLEANING AND BEFORE THE MARKING MATERIAL CAN BE APPLIED.

THE FILLING OF TANKS, POURING OF MATERIALS OR CLEANING OF EQUIPMENT SHALL NOT BE PERFORMED ON UNPROTECTED PAVEMENT SURFACES UNLESS ADEQUATE PROVISIONS ARE MADE TO PREVENT SPILLAGE OF MATERIAL.

**SYMBOLS & MATERIALS LEGEND**

CROSSWALK BLOCK WHITE - PREFORMED THERMOPLASTIC

PAVEMENT MESSAGE (LEFT ARROW) PREFORMED THERMOPLASTIC

**STRIPING KEY**

CIRCLE - EPOXY SQUARE - PREFORMED THERMOPLASTIC

TRIANGLE - PAINT

PENTAGON - REMOVABLE PREFORMED PLASTIC MARKING

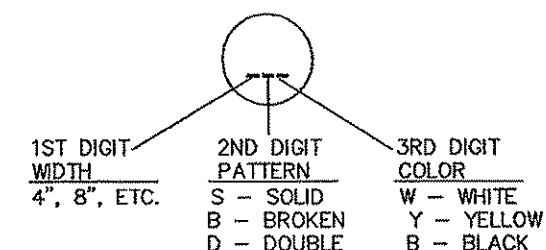

EXAMPLE: = 4" SOLID LINE WHITE - EPOXY

PERMANENT PAVEMENT MARKING TABULATION			H
ITEM	UNIT	TOTAL QUANTITY	
PAVEMENT MARKING REMOVAL	LIN FT	9274	
PAVEMENT MSSG (LT ARROW) PREFORMED THERMOPLASTIC	EACH	13	
PAVEMENT MSSG (RT ARROW) PREFORMED THERMOPLASTIC	EACH	7	
24" SOLID LINE YELLOW - PREFORMED THERMOPLASTIC	LIN FT	449	
24" SOLID LINE WHITE - PREFORMED THERMOPLASTIC	LIN FT	51	
3' x 6' CROSSWALK MARKING - PREFORMED THERMOPLASTIC	SQ FT	1017	
4" SOLID LINE WHITE - EPOXY	LIN FT	12127	
4" SOLID LINE YELLOW - EPOXY	LIN FT	5508	
4" BROKEN LINE WHITE - EPOXY (10' STRIPE / 40' GAP)	LIN FT	1060	
4" DOUBLE SOLID LINE YELLOW - EPOXY	LIN FT	1871	

NO	DATE	BY	CHKD	APPR	REVISION

I HEREBY CERTIFY THAT THIS PLAN WAS PREPARED BY ME OR UNDER MY DIRECT SUPERVISION AND THAT I AM A DULY LICENSED PROFESSIONAL ENGINEER UNDER THE LAWS OF THE STATE OF MINNESOTA.  
 PRINT NAME: CURT A. KOBILARCSIK  
 SIGNATURE:   
 DATE: 6-7-12 LICENSE NO. 24756

DRAWN BY: MTH DATE 4/03/12  
 DESIGN BY: MTH DATE 4/03/12  
 CHECKED BY: JKR DATE 4/12/12



**ANOKA COUNTY**  
**HIGHWAY DEPT.**

S.P. 0208-145  
 S.A.P. 002-716-013  
 S.A.P. 197-020-004

**PERMANENT MARKING**  
**TABULATION**

Sheet 84 of 108 Sheets



- NOTES:  
 ① FURNISH AND INSTALL  
 ④ INSTALL SALVAGED SIGN  
 ⑨ RETAIN INPLACE SIGN

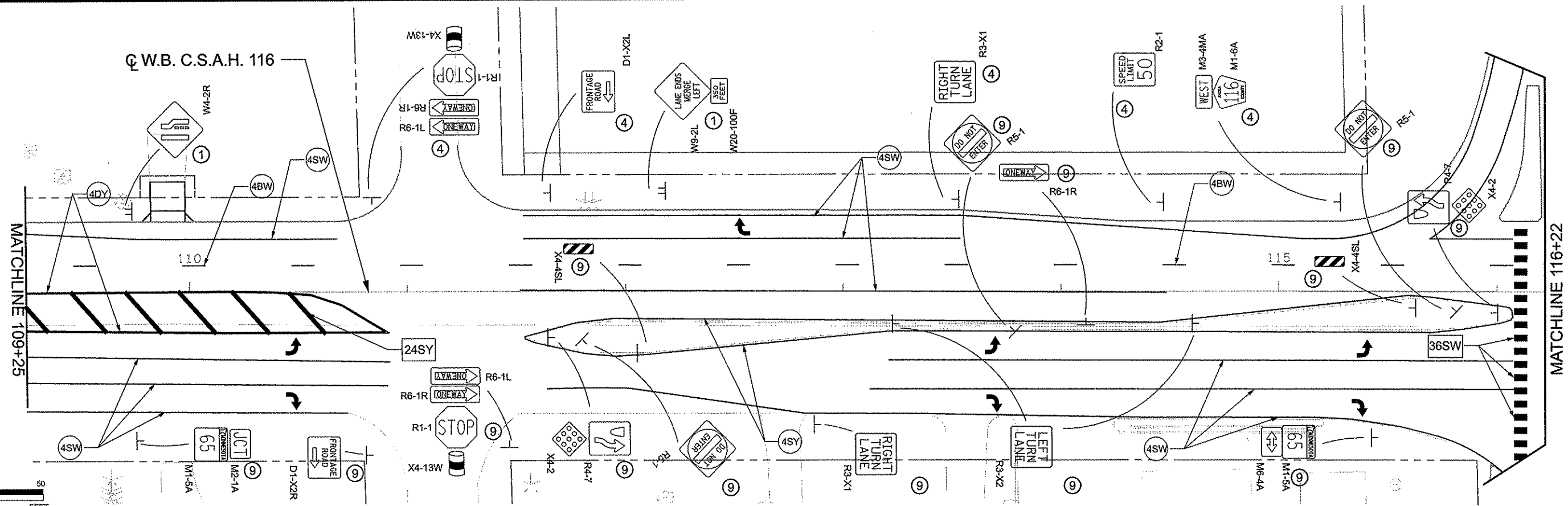
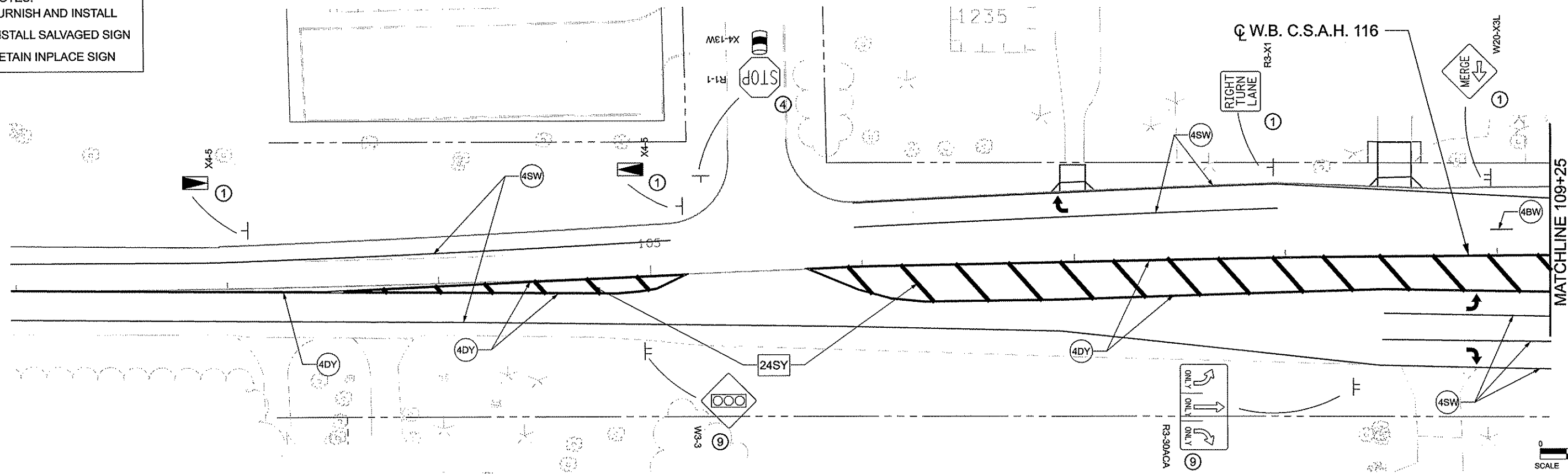

1 OF 4

NO.	DATE	BY	CKD	APPR	REVISION
NAME: p1116-65\plan116-65_STP_P1.dgn					
05/23/2012 9:46:06 AM					

I HEREBY CERTIFY THAT THIS PLAN WAS PREPARED BY ME OR UNDER MY DIRECT SUPERVISION AND THAT I AM A DULY LICENSED PROFESSIONAL ENGINEER UNDER THE LAWS OF THE STATE OF MINNESOTA.  
 PRINT NAME: Curt Kobilarosik  
 SIGNATURE: *Curt Kobilarosik*  
 DATE: 5-23-12 LICENSE NO. 24756

DRAWN BY: DFF DATE: 03-20-12  
 DESIGN BY: DFF DATE: 03-20-12  
 CHECKED BY: JKR DATE: 03-30-12

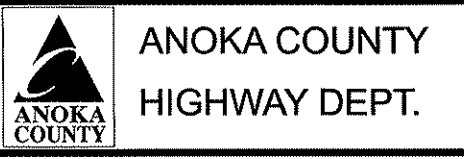

S.P. 0208-145 (T.H. 65)  
 S.A.P. 002-716-013  
 S.A.P. 197-020-004

SIGNING AND STRIPING PLAN  
 STA 102+00 TO 116+50  
 Sheet 65 of 108 Sheets

- NOTES:
- ① FURNISH AND INSTALL
  - ④ INSTALL SALVAGED SIGN
  - ⑨ RETAIN INPLACE SIGN

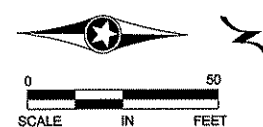
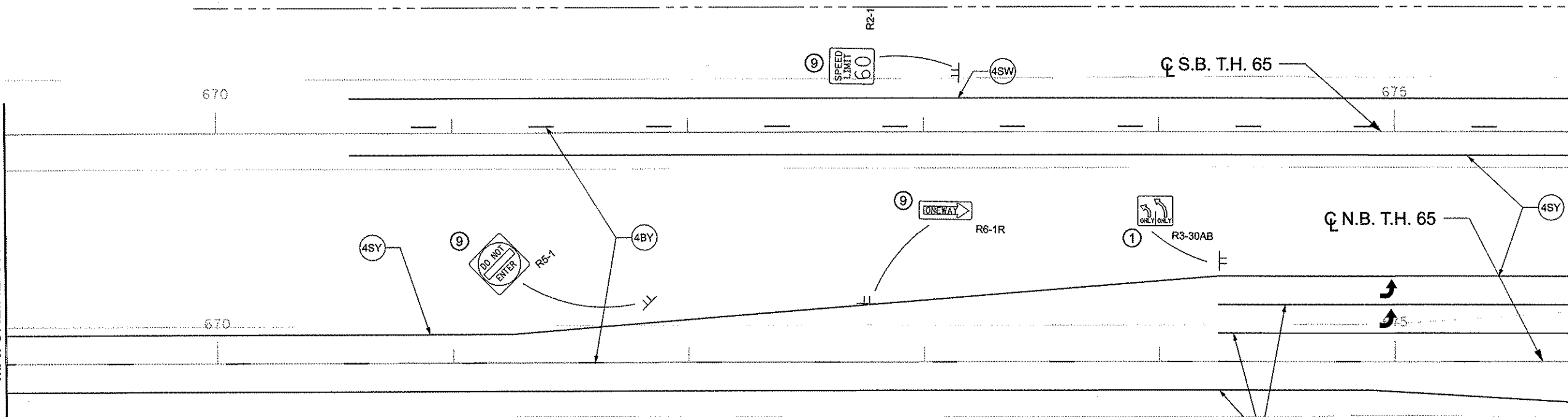
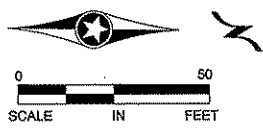
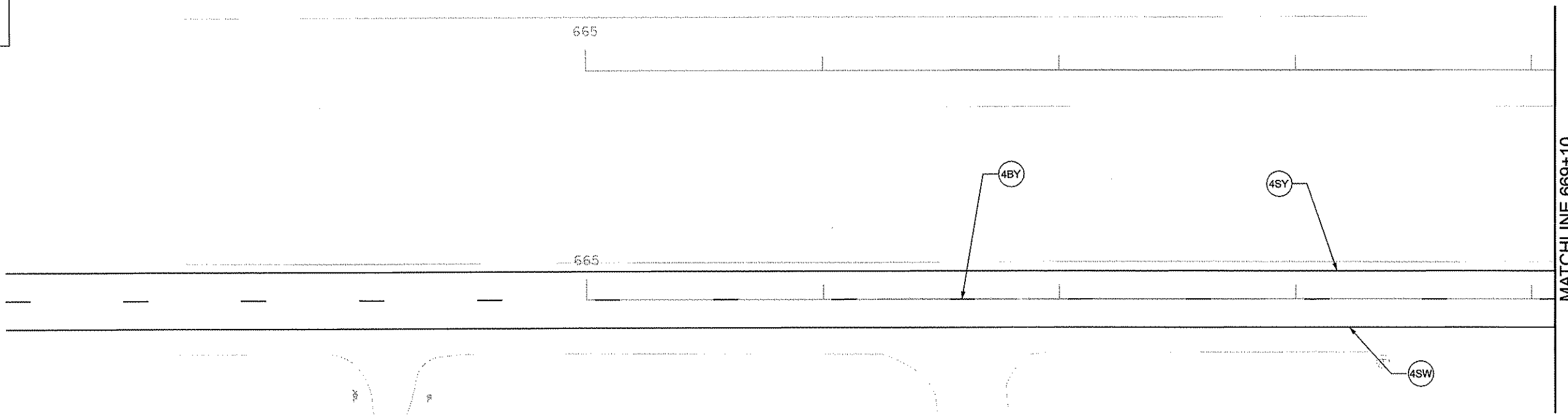

NO	DATE	BY	CKD	APPR	REVISION

NAME: p:\116-65\plant\116-65\_STP\_P2.dgn      05/23/2012      9:46:10 AM

I HEREBY CERTIFY THAT THIS PLAN WAS PREPARED BY ME OR UNDER MY DIRECT SUPERVISION AND THAT I AM A DULY LICENSED PROFESSIONAL ENGINEER UNDER THE LAWS OF THE STATE OF MINNESOTA.

PRINT NAME: Curt Kobliarski

SIGNATURE: *Curt Kobliarski*

DATE: 5-23-12      LICENSE NO. 24756

DRAWN BY: DFF      DATE: 03-20-12

DESIGN BY: DFF      DATE: 03-20-12

CHECKED BY: JKR      DATE: 03-30-12



S.P. 0208-145 (T.H. 65)  
S.A.P. 002-716-013  
S.A.P. 197-020-004

SIGNING AND STRIPING PLAN

STA \_\_\_\_\_ TO 675+75

Sheet 66 of 108 Sheets

- NOTES:  
 ① FURNISH AND INSTALL  
 ④ INSTALL SALVAGED SIGN  
 ⑨ RETAIN INPLACE SIGN

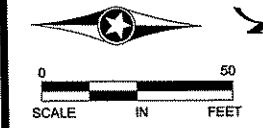
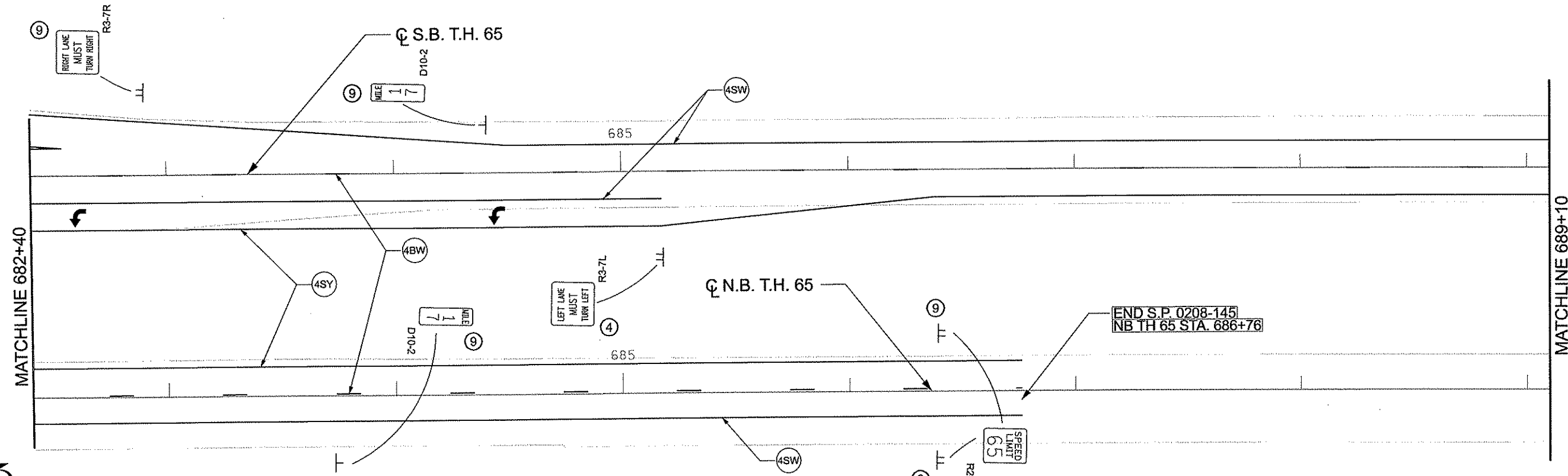
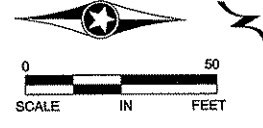
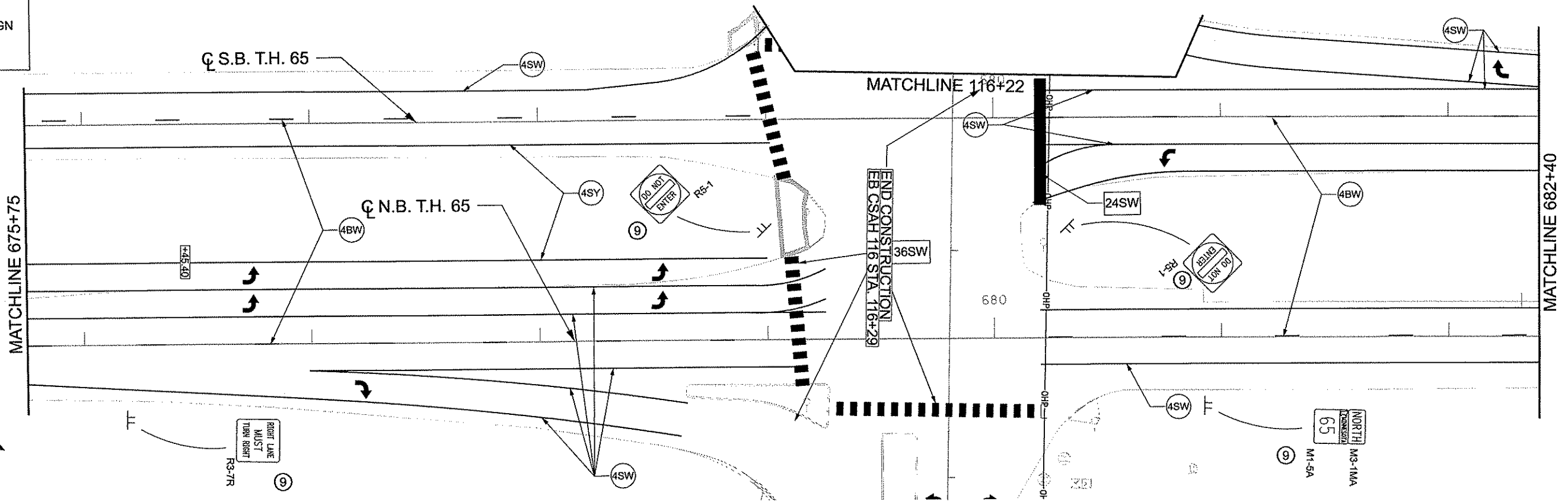

NO	DATE	BY	CKD	APPR	REVISION
NAME: p:\116-65\plan\116-65_STP_P3.dgn					
06/08/2012 12:46:34 PM					

I HEREBY CERTIFY THAT THIS PLAN WAS PREPARED BY ME OR UNDER MY DIRECT SUPERVISION AND THAT I AM A DULY LICENSED PROFESSIONAL ENGINEER UNDER THE LAWS OF THE STATE OF MINNESOTA.  
 PRINT NAME: Curt Koblarcsik  
 SIGNATURE: *Curt Koblarcsik*  
 DATE: 6-7-12 LICENSE NO. 24758

DRAWN BY: DFF DATE: 03-20-12  
 DESIGN BY: DFF DATE: 03-20-12  
 CHECKED BY: JKR DATE: 03-30-12

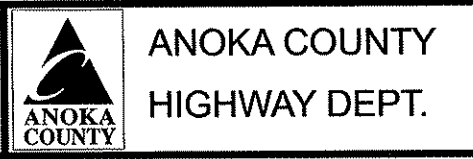

S.P. 0208-145 (T.H. 65)  
 S.A.P. 002-716-013  
 S.A.P. 197-020-004

SIGNING AND STRIPING PLAN  
 STA 675+75 TO 689+10  
 Sheet 67 of 108 Sheets

- NOTES:  
 ① FURNISH AND INSTALL  
 ④ INSTALL SALVAGED SIGN  
 ⑨ RETAIN INPLACE SIGN

MATCHLINE 689+10

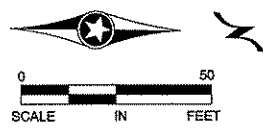
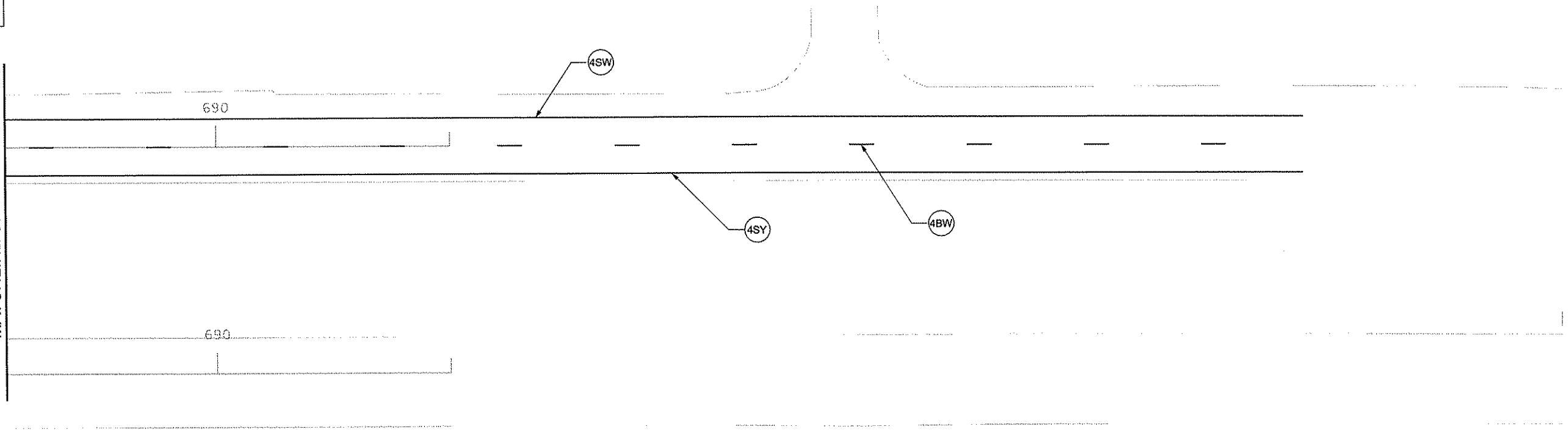

M.U.T.C.D. CODE	SIZE	INSERT	QUANTITY	PANEL AREA SQ. FT.	TOTAL AREA SQ. FT.	MOUNTING INSTALLATION	MOUNTING HEIGHT	NOTES
R3-30AB	36" x 30"		1	7.50	7.5	2	7.0'	TH 65
R3-X1	30" x 30"		1	6.25	6.3	1	7.0'	
W4-2R	48" x 48"		1	16.00	16.0	2	7.0'	
W9-2L	48" x 48"		1	16.00	16.0	2	7.0'	
W20-100F	30" x 24"		1	5.00	5.0			1
W20-X3L	48" x 48"		1	16.00	16.0	2	7.0'	
X4-5	6" x 12"		2	0.50	1.0	1	4.0'	

GENERAL NOTES:  
 ALL TRAFFIC CONTROL DEVICES SHALL CONFORM TO THE MOST RECENT EDITION OF THE MINNESOTA MANUAL ON UNIFORM TRAFFIC CONTROL DEVICES INCLUDING THE FIELD MANUAL DATED JANUARY, 2011.  
 LOCATIONS OF PAVEMENT MARKINGS ARE APPROXIMATE. EXACT LOCATIONS WILL BE DETERMINED IN THE FIELD BY THE ENGINEER.  
 ALL PERMANENT STRIPING AND PAVEMENT MESSAGES SHALL BE PLACED WITHIN 72 HOURS OF MAINLINE PAVING.

SIGNING NOTES:  
 1. MOUNT DIRECTLY BELOW W9-2L

NO	DATE	BY	CHKD	APPR	REVISION

NAME: p:\116-65\Plan\116-65\_STP\_P4.dgn      05/23/2012      9:46:16 AM

I HEREBY CERTIFY THAT THIS PLAN WAS PREPARED BY ME OR UNDER MY DIRECT SUPERVISION AND THAT I AM A DULY LICENSED PROFESSIONAL ENGINEER UNDER THE LAWS OF THE STATE OF MINNESOTA.  
 PRINT NAME: Curt Kobilaroski  
 SIGNATURE:

DRAWN BY: DFP      DATE: 03-20-12  
 DESIGN BY: DFP      DATE: 03-20-12  
 CHECKED BY: JKR      DATE: 03-30-12

**ANOKA COUNTY**  
**HIGHWAY DEPT.**

S.P. 0208-145 (T.H. 65)  
 S.A.P. 002-716-013  
 S.A.P. 197-020-004

SIGNING AND STRIPING PLAN  
 STA 689+10 TO           
 Sheet 68 of 108 Sheets

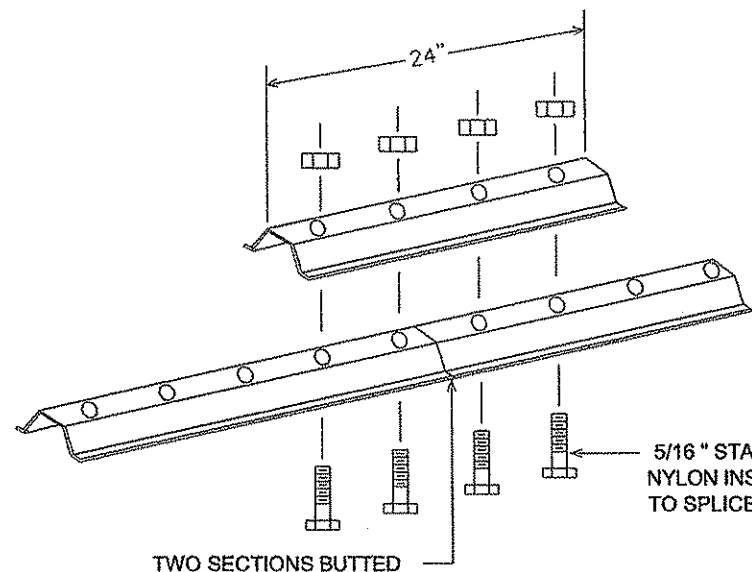

LATERAL BRACE OR STRINGER  
SPLICE DETAIL (EXPLODED VIEW)

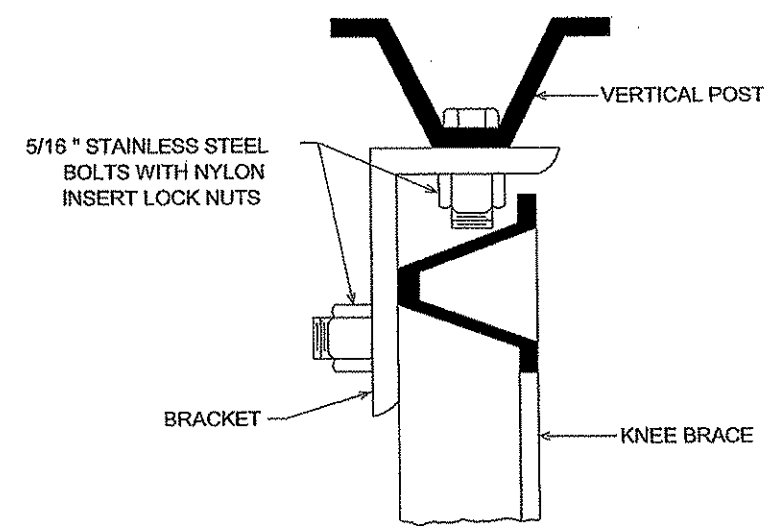

SECTION A-A

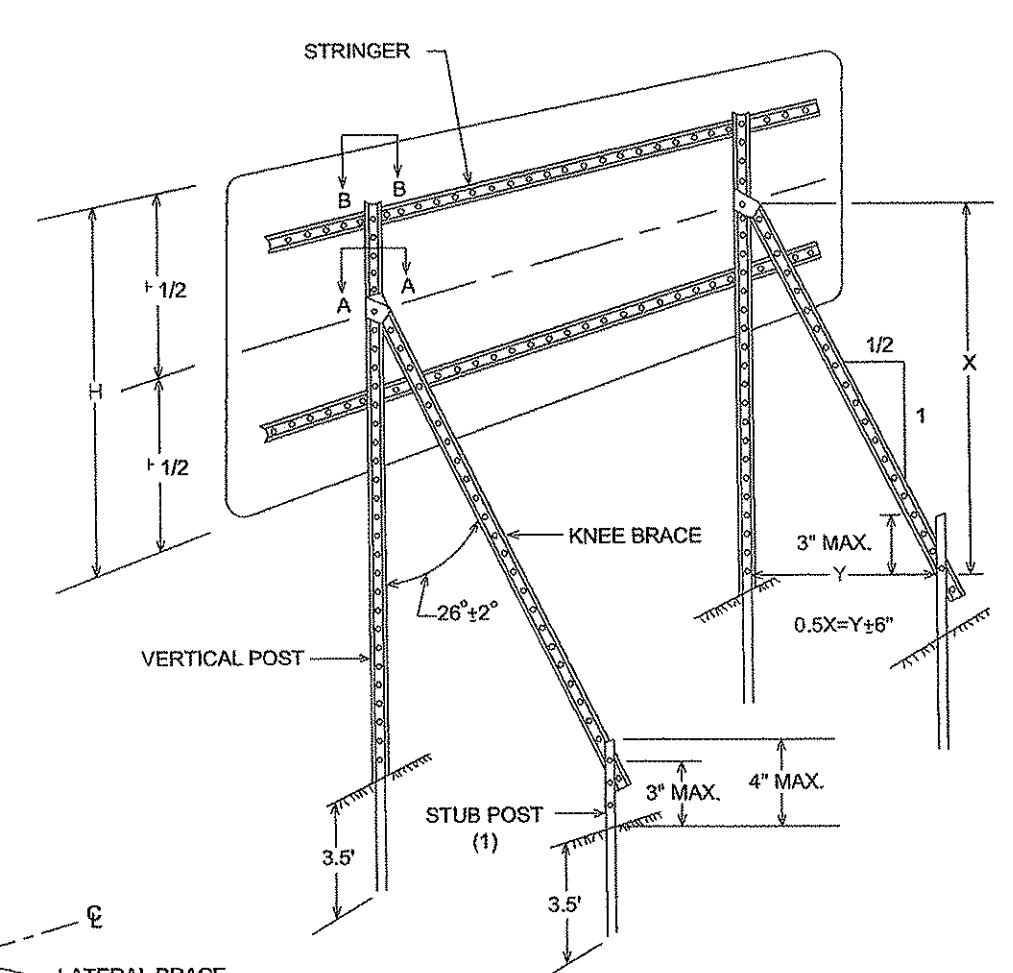

TYPICAL "A-FRAME" INSTALLATION  
TYPE "D" SIGNS

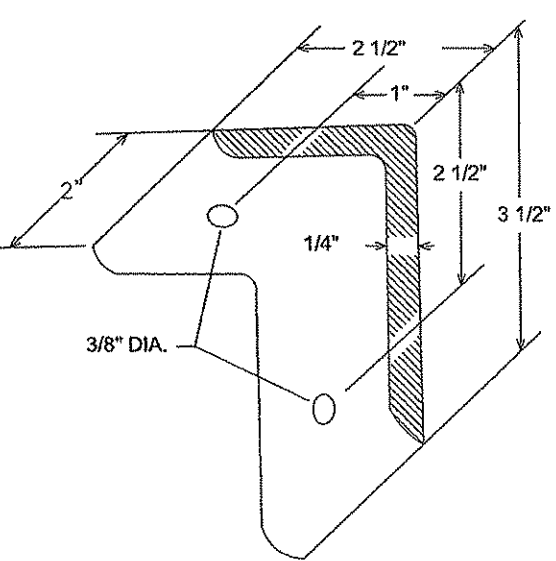

A-FRAME BRACKET

(STEEL MN/DOT 3306 GALVANIZED PER MN/DOT 3394)

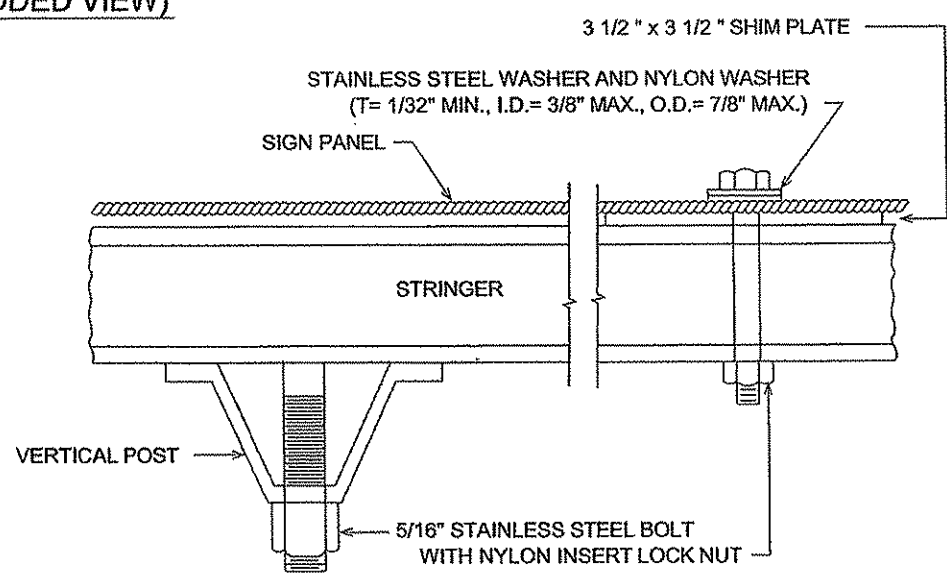

SECTION B-B

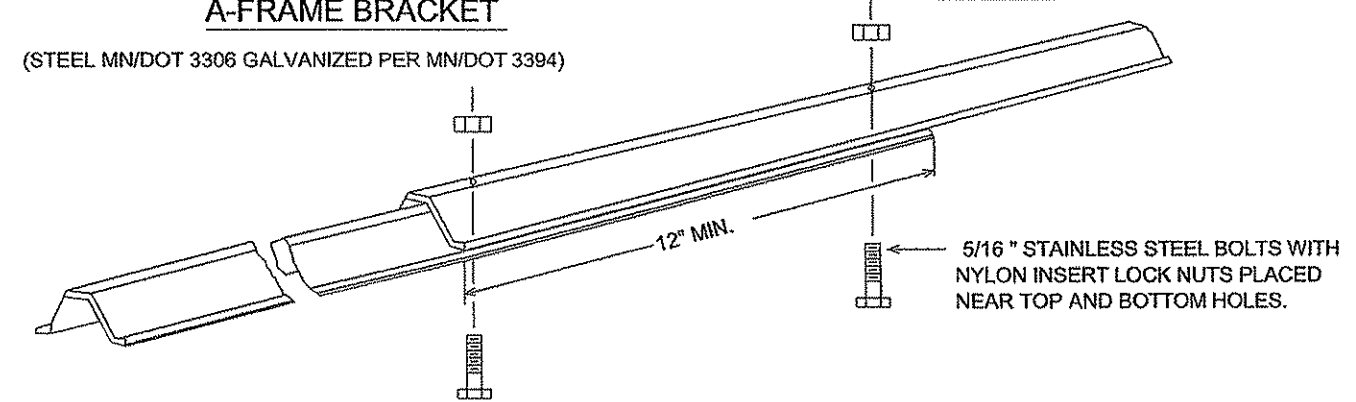

KNEE BRACE SPLICE

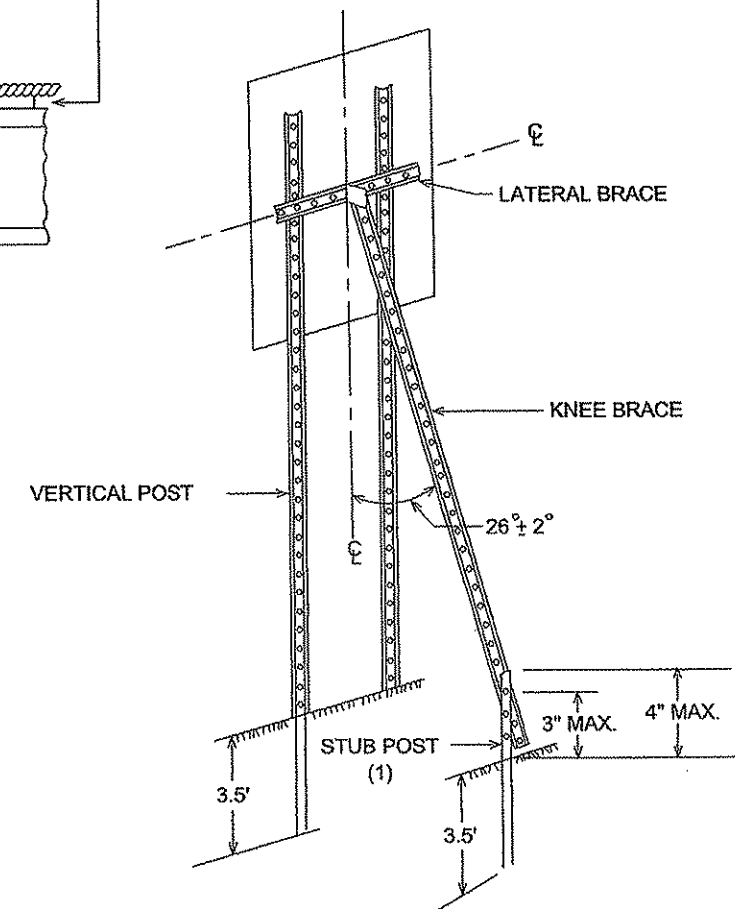

TYPICAL "A-FRAME" INSTALLATION  
TYPE "C" SIGNS

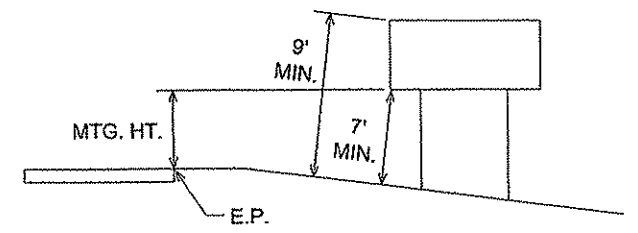

TYPICAL MOUNTING

(1) OFFSET STUB POST 1' TOWARD ROADWAY  
RELATIVE TO VERTICAL POST.

TYPE C & D SIGN  
STRUCTURAL DETAILS

NO	DATE	BY	CKD	APPR	REVISION

I HEREBY CERTIFY THAT THIS PLAN WAS PREPARED BY ME OR UNDER MY DIRECT SUPERVISION AND THAT I AM A DULY LICENSED PROFESSIONAL ENGINEER UNDER THE LAWS OF THE STATE OF MINNESOTA.  
 PRINT NAME: CURT A. KOBILARCSIK  
 SIGNATURE: *Curt Kobilarcsik*  
 DATE: 6-7-12 LICENSE NO. 24766

DRAWN BY MTH DATE 04-03-12  
 DESIGN BY MTH DATE 04-03-12  
 CHECKED BY JR DATE 4-12-12



ANOKA COUNTY  
HIGHWAY DEPT.

S.P. 0208-145  
 S.A.P. 002-716-013  
 S.A.P. 197-020-004

SIGNING & STRIPING DETAILS  
 Sheet 69 of 108 Sheets

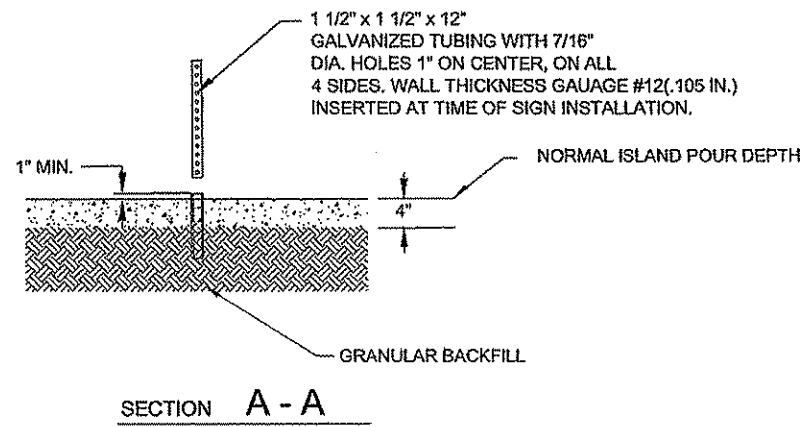
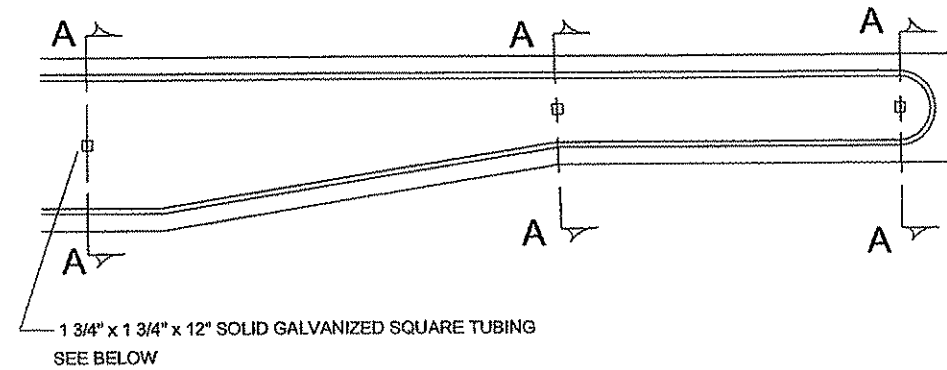

GROUND POST MOUNT SIGN  
INSTALLATION TYPICAL

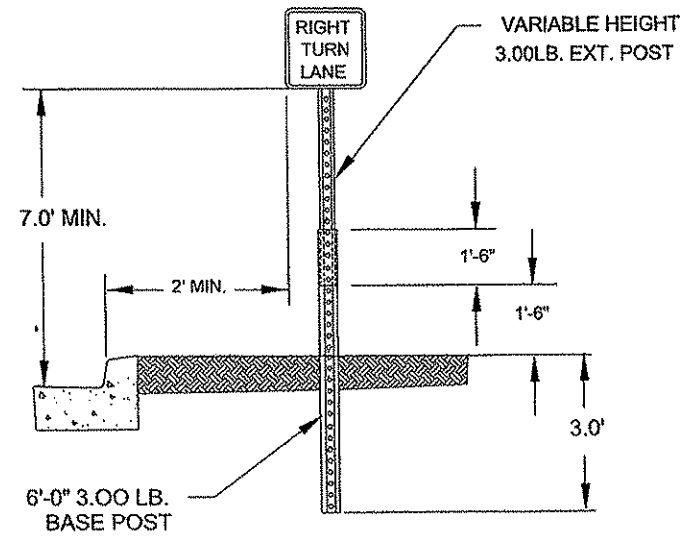

ISLAND MOUNT BREAK-AWAY SIGN  
INSTALLATION TYPICAL

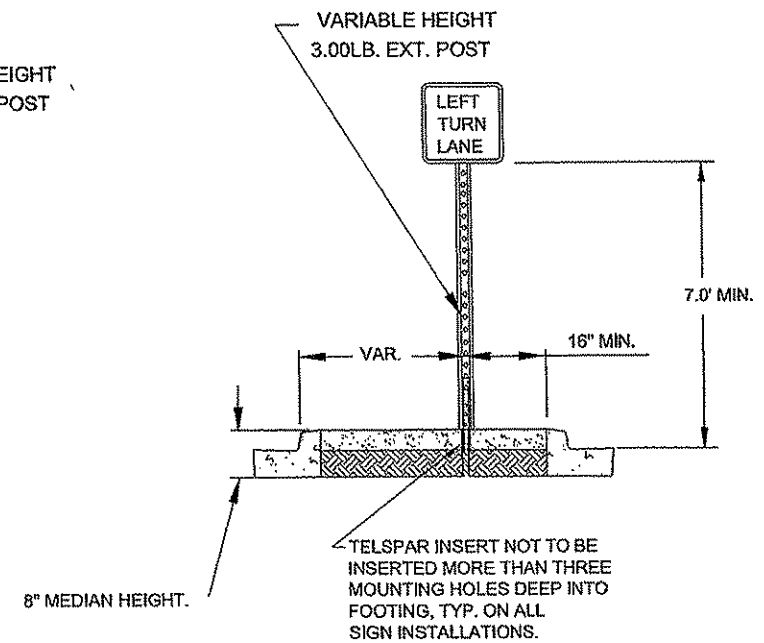

NO	DATE	BY	CHKD	APPR	REVISION

I HEREBY CERTIFY THAT THIS PLAN WAS PREPARED BY ME OR UNDER MY DIRECT SUPERVISION AND THAT I AM A DULY LICENSED PROFESSIONAL ENGINEER UNDER THE LAWS OF THE STATE OF MINNESOTA.

PRINT NAME: CURT A. KOBILARCSIK  
 SIGNATURE: *Curt Kobilarsik*  
 DATE: 6-7-12 LICENSE NO. 24756

DRAWN BY: MTH DATE: 04-03-12  
 DESIGN BY: MTH DATE: 04-03-12  
 CHECKED BY: JR DATE: 4-12-12



ANOKA COUNTY  
HIGHWAY DEPT.

S.P. 0208-145  
 S.A.P. 002-716-013  
 S.A.P. 197-020-004

SIGNING & STRIPING DETAILS  
 Sheet 70 of 108 Sheets

RURAL

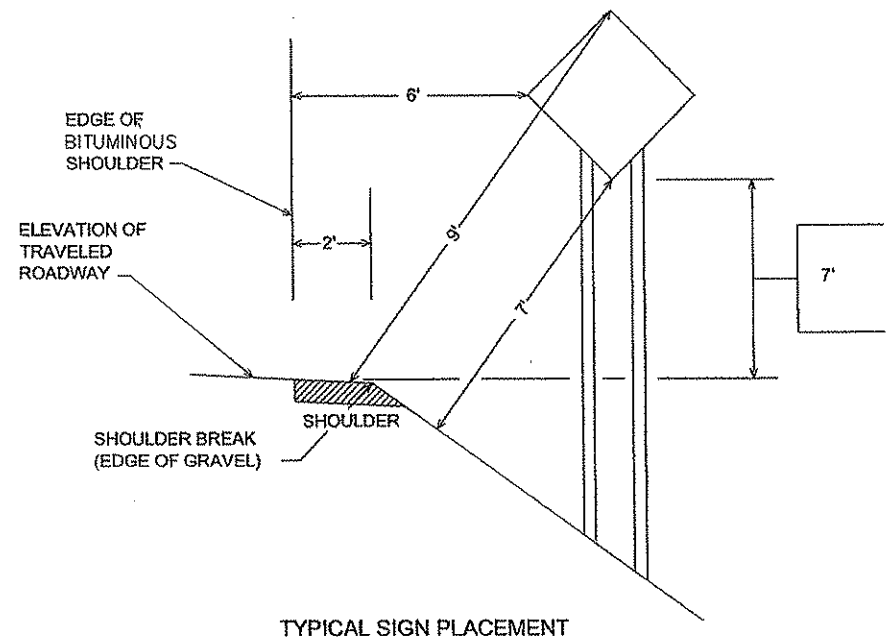

URBAN

2' - NARROW BOULEVARD (< 8' WIDE)  
6' - WIDE BOULEVARD

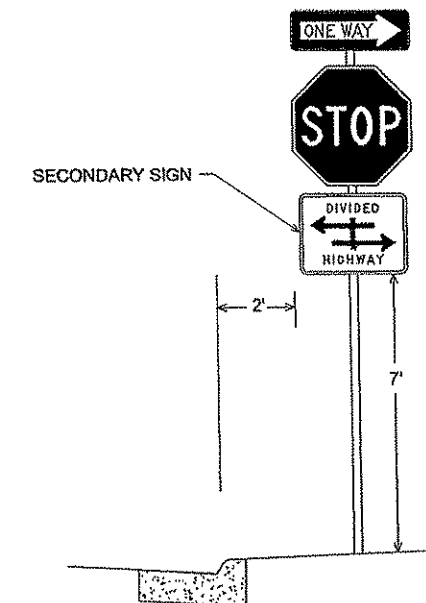
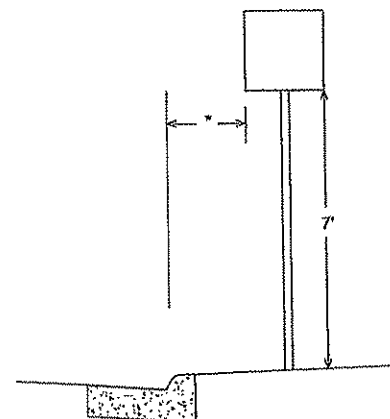

NOTE:  
- ALL DIMENSIONS ARE MINIMUMS  
- MAINTAIN 2' CLEAR FROM SIGNS TO BITUMINOUS TRAIL.

NO	DATE	BY	CHKD	APPR	REVISION

I HEREBY CERTIFY THAT THIS PLAN WAS PREPARED BY ME OR UNDER MY DIRECT SUPERVISION AND THAT I AM A DULY LICENSED PROFESSIONAL ENGINEER UNDER THE LAWS OF THE STATE OF MINNESOTA.

PRINT NAME: CURT A. KOBIARCSIK

SIGNATURE: *Curt A. Kobiarczik*

DATE: 6-7-12 LICENSE NO. 24756

DRAWN BY MTH DATE 04-03-12

DESIGN BY MTH DATE 04-03-12

CHECKED BY JR DATE 4-12-12

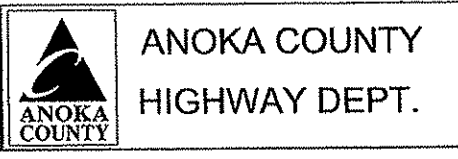

S.P. 0208-145  
S.A.P. 002-716-013  
S.A.P. 197-020-004

SIGNING & STRIPING DETAILS

Sheet 71 of 108 Sheets

**TYPICAL MESSAGE PLACEMENT  
FOR TURN LANES**

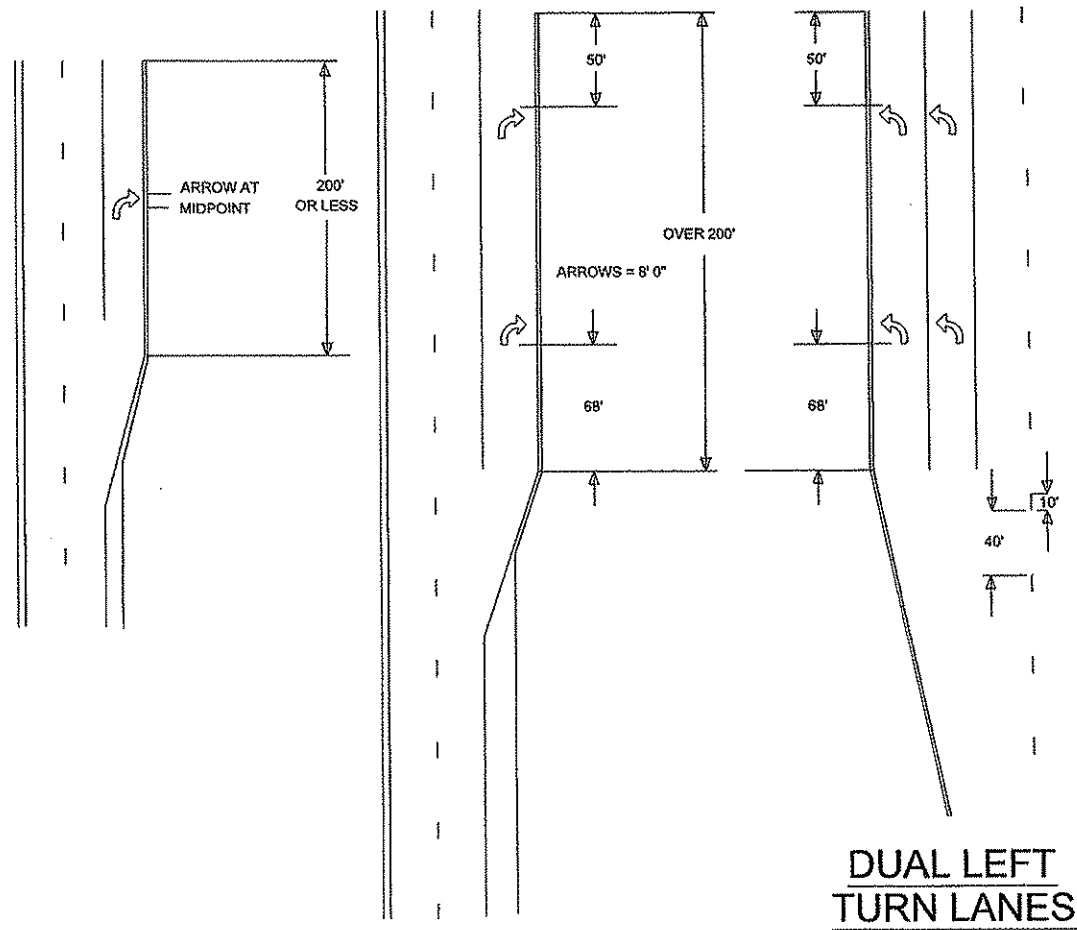

**TYPICAL MARKINGS FOR  
LEFT TURN ISLANDS**

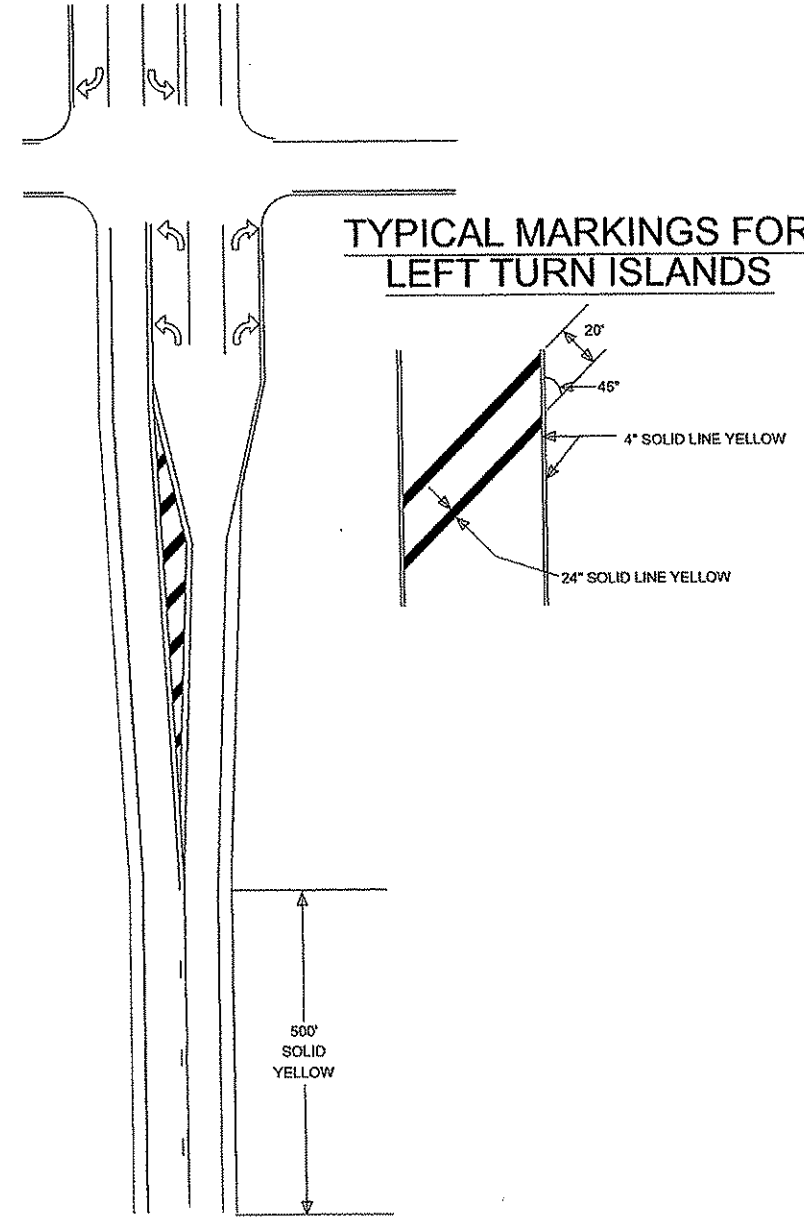

NO	DATE	BY	CKD	APPR	REVISION

NAME: P:\116-65\Base\TRAFFIC\Sign&Stripe\_Details.dwg

I HEREBY CERTIFY THAT THIS PLAN WAS PREPARED BY ME OR UNDER MY DIRECT SUPERVISION AND THAT I AM A DULY LICENSED PROFESSIONAL ENGINEER UNDER THE LAWS OF THE STATE OF MINNESOTA.

PRINT NAME: CURT A. KOBILARCSIK

SIGNATURE: *Curt Kobilarcsik*

DATE: 6-7-12 LICENSE NO. 24766

DRAWN BY MTH DATE 04-03-12

DESIGN BY MTH DATE 04-03-12

CHECKED BY JR DATE 4-12-12



**ANOKA COUNTY  
HIGHWAY DEPT.**

S.P. 0208-145  
S.A.P. 002-716-013  
S.A.P. 197-020-004

SIGNING & STRIPING DETAILS

Sheet 72 of 108 Sheets



# MARKINGS FOR PEDESTRIAN CROSSWALKS

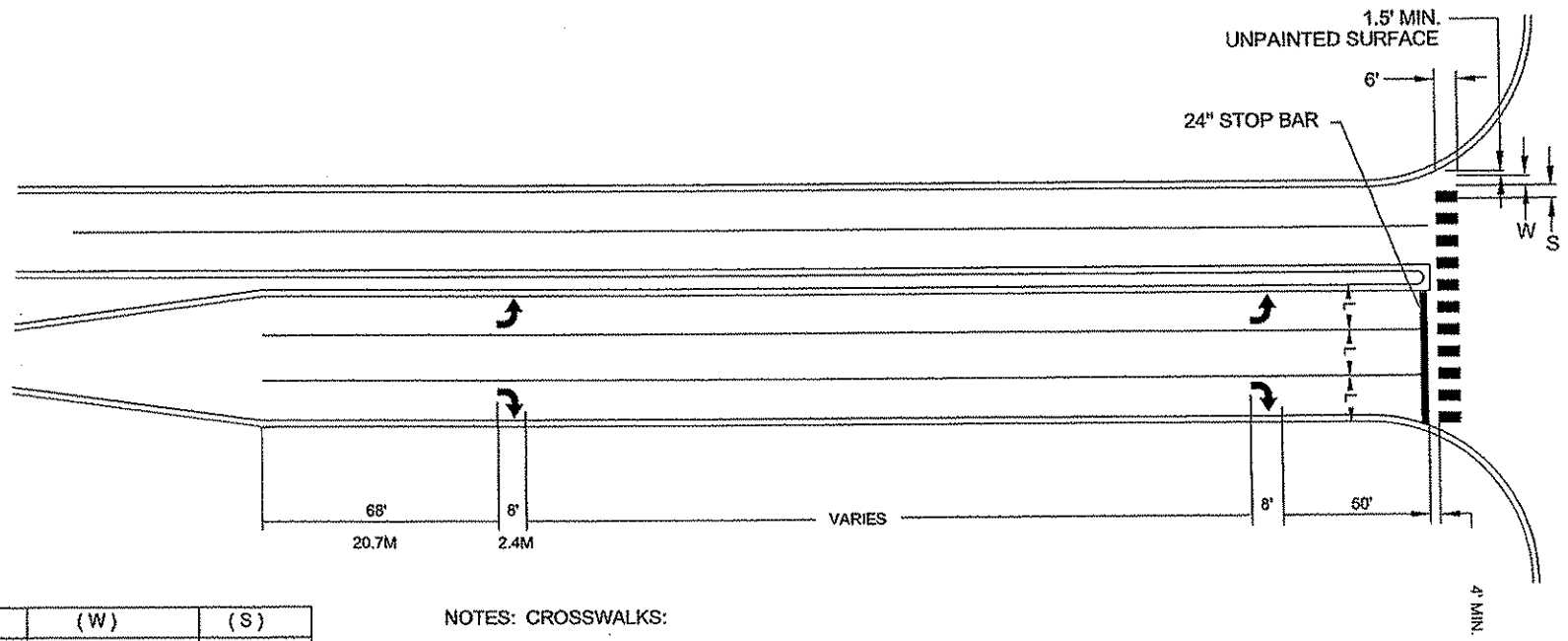

(L)	(W)	(S)
WIDTH OF INSIDE LANE	WIDTH OF PAINTED AREAS	WIDTH OF SPACE
9'	2.5'	2.5'
10'	2.5'	2.5'
11'	2.5'	3.0'
12'	3.0'	3.0'
13'	3.0'	3.5'

**NOTES: CROSSWALKS:**

- 1.) PAINTED AREAS ARE TO BE CENTERED ON CENTER AND LANE LINES, EVEN IF INTERSECTION IS NOT ALIGNED.
- 2.) LOCATION OF ZEBRA CROSSWALKS AND STOP BARS, SIGNAL LOOPS AND PED RAMP ARE APPROXIMATE. FINAL LOCATIONS ARE TO BE DETERMINED AND FIELD VERIFIED DURING CONSTRUCTION BY THE FIELD ENGR.
- 3.) ZEBRA CROSSWALKS ARE TO BE PARALLEL TO THE DRIVING LANE OR LANES, EVEN IF THE STREET IS ON AN ANGLE TO THE INTERSECTION.
- 4.) A MIN. OF 1.5' (450mm) CLEAR DISTANCE MUST BE LEFT ADJACENT TO THE CURB. IF LAST PAINTED AREA FALLS INTO THIS AREA, IT MUST BE OMITTED.
- 5.) ON TWO LANE STREETS, USE SPACING SHOWN FOR AN 11' (3.3mm) NSIDE LANE.

NO	DATE	BY	CHKD	APPR	REVISION

I HEREBY CERTIFY THAT THIS PLAN WAS PREPARED BY ME OR UNDER MY DIRECT SUPERVISION AND THAT I AM A DULY LICENSED PROFESSIONAL ENGINEER UNDER THE LAWS OF THE STATE OF MINNESOTA.

PRINT NAME: CURT A. KOBILARCSIK  
 SIGNATURE: *Curt Kobilarcsik*  
 DATE: 6-7-12 LICENSE NO. 24756

DRAWN BY MTH DATE 04-03-12  
 DESIGN BY MTH DATE 04-03-12  
 CHECKED BY JR DATE 4-12-12



**ANOKA COUNTY  
HIGHWAY DEPT.**







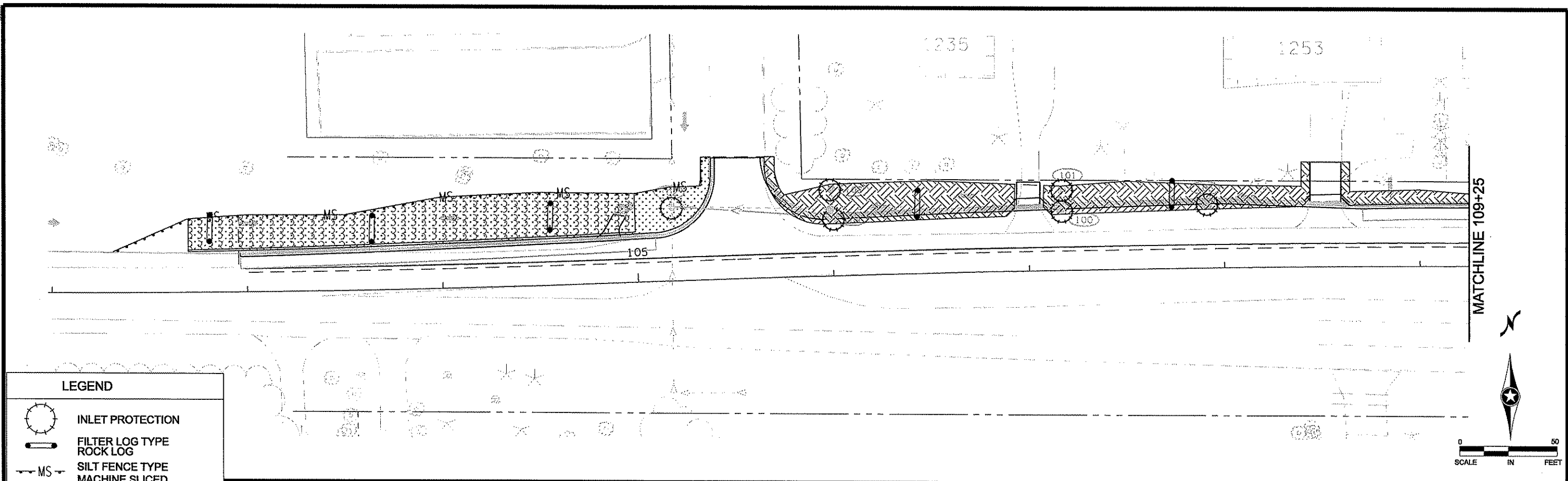



S.P. 0208-145  
 S.A.P. 002-716-013  
 S.A.P. 197-020-004

SIGNING & STRIPING DETAILS

Sheet 73 of 108 Sheets



**LEGEND**

-  INLET PROTECTION
-  FILTER LOG TYPE
-  ROCK LOG
-  MS SILT FENCE TYPE
-  MACHINE SLICED
-  FLOW DIRECTION
-  CONSTRUCTION LIMIT
-  SEEDING
-  EROSION CONTROL BLANKET CATEGORY 0
-  SODDING TYPE SALT RESISTANT

- GENERAL NOTES:**
- 1.) SILT FENCE SHALL FOLLOW AS CLOSE AS POSSIBLE A SINGLE CONTOUR.
  - 2.) SILT FENCE SHALL BE CLEANED OUT OR REPLACED WHEN SEDIMENT REACHES 8" OR 1/3 OF SILT FENCE HEIGHT.
  - 3.) IF SILT DEPOSITS IN THE ANOKA COUNTY RIGHT OF WAY, THE CONTRACTOR IS RESPONSIBLE FOR ITS REMOVAL.
  - 4.) ALL GRADED AREAS ARE TO BE REVEGETATED WITHIN 14 DAYS OF THE COMPLETION OF GRADING.

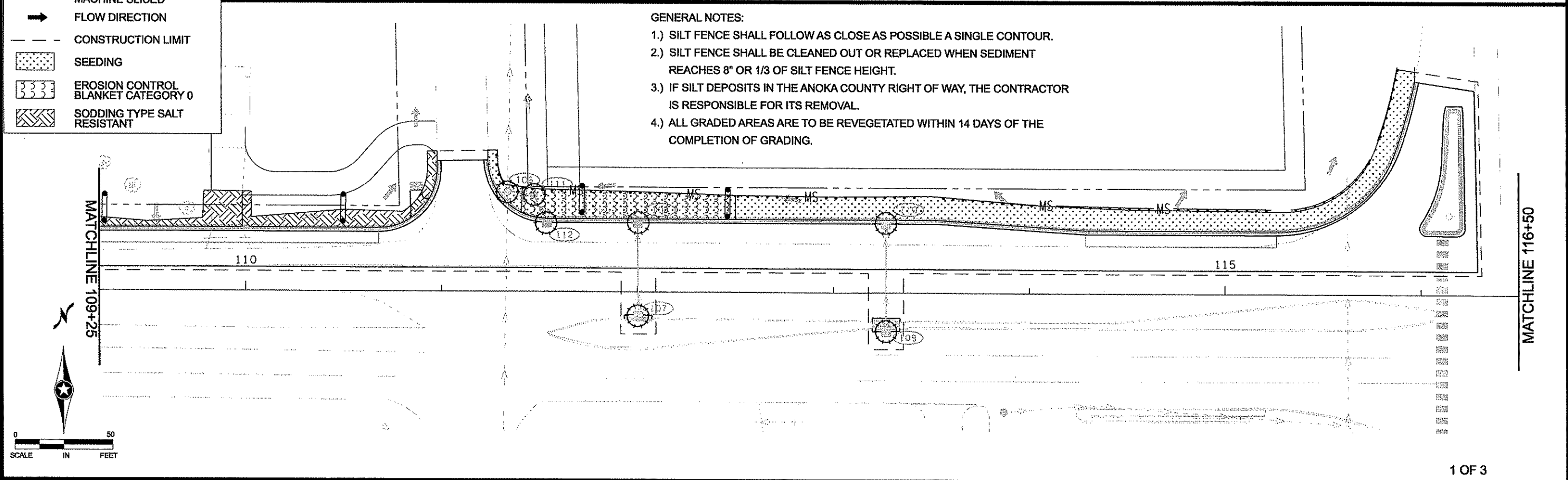

1	6/25/12	BAV	JEO	CAK	TURF ESTABLISHMENT MODIFIED
NO	DATE	BY	CKD	APPR	REVISION
NAME: p:\118-85\plan\116-65_EC_P1.dgn					
06/28/2012 11:42:48 AM					

I HEREBY CERTIFY THAT THIS PLAN WAS PREPARED BY ME OR UNDER MY DIRECT SUPERVISION AND THAT I AM A DULY LICENSED PROFESSIONAL ENGINEER UNDER THE LAWS OF THE STATE OF MINNESOTA.

PRINT NAME: Curt Kobilaroski  
 SIGNATURE: *Curt Kobilaroski*  
 DATE: 6-27-12 LICENSE NO. 24758

DRAWN BY: BAV DATE: 3-23-12  
 DESIGN BY: BAV DATE: 3-23-12  
 CHECKED BY: JEO DATE: 4-10-12

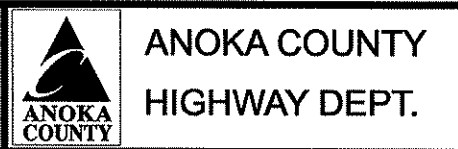

S.P. 0208-145 (T.H. 65)  
 S.A.P. 002-716-013  
 S.A.P. 197-020-004

1 OF 3

**TURF ESTABLISHMENT AND EROSION CONTROL**  
 STA 102+00 TO 116+50

Sheet 74 of 108 Sheets

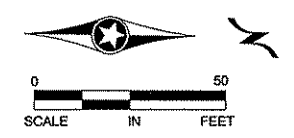
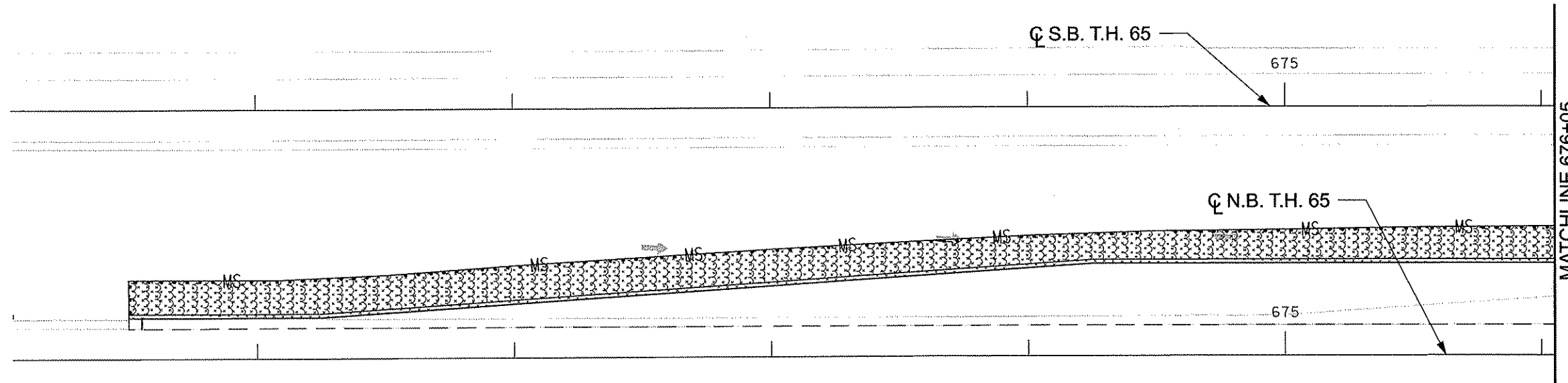

- GENERAL NOTES:
- 1.) SILT FENCE SHALL FOLLOW AS CLOSE AS POSSIBLE A SINGLE CONTOUR.
  - 2.) SILT FENCE SHALL BE CLEANED OUT OR REPLACED WHEN SEDIMENT REACHES 8" OR 1/3 OF SILT FENCE HEIGHT.
  - 3.) IF SILT DEPOSITS IN THE ANOKA COUNTY RIGHT OF WAY, THE CONTRACTOR IS RESPONSIBLE FOR ITS REMOVAL.
  - 4.) ALL GRADED AREAS ARE TO BE REVEGETATED WITHIN 14 DAYS OF THE COMPLETION OF GRADING.

**LEGEND**

- INLET PROTECTION
- FILTER LOG TYPE
- ROCK LOG
- SILT FENCE TYPE
- MACHINE SLICED
- FLOW DIRECTION
- CONSTRUCTION LIMIT
- SEEDING
- EROSION CONTROL BLANKET CATEGORY 0
- SODDING TYPE SALT RESISTANT

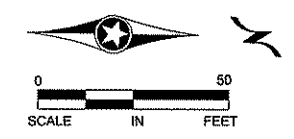
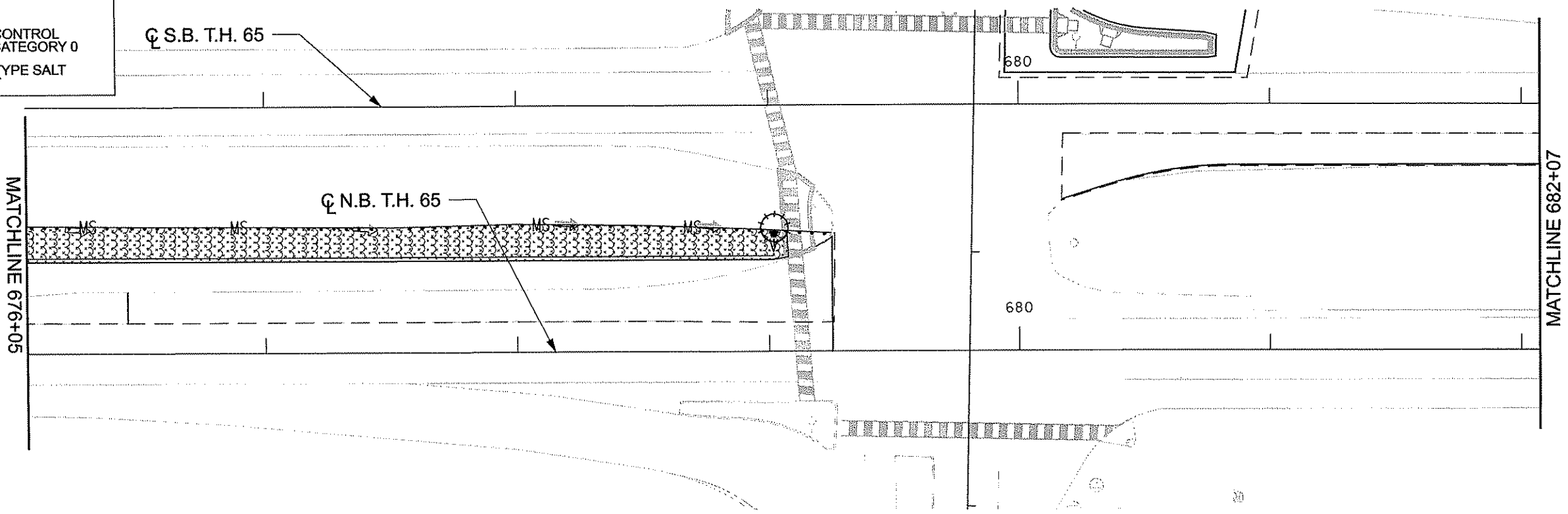

NO	DATE	BY	CKD	APPR	REVISION

NAME: p:\116-65\plan\116-65\_EC\_P2.dgn 06/08/2012 12:46:42 PM

I HEREBY CERTIFY THAT THIS PLAN WAS PREPARED BY ME OR UNDER MY DIRECT SUPERVISION AND THAT I AM A DULY LICENSED PROFESSIONAL ENGINEER UNDER THE LAWS OF THE STATE OF MINNESOTA.

PRINT NAME: Curt Kobilarski

SIGNATURE:

DATE: 6-7-12 LICENSE NO. 24756

DRAWN BY BAV DATE 3-23-12

DESIGN BY BAV DATE 3-23-12

CHECKED BY JEO DATE 4-10-12

**ANOKA COUNTY**  
**HIGHWAY DEPT.**

S.P. 0208-145 (T.H. 65)  
S.A.P. 002-716-013  
S.A.P. 197-020-004

**TURF ESTABLISHMENT AND EROSION CONTROL**

STA 676+05 TO 682+07

Sheet 75 of 108 Sheets

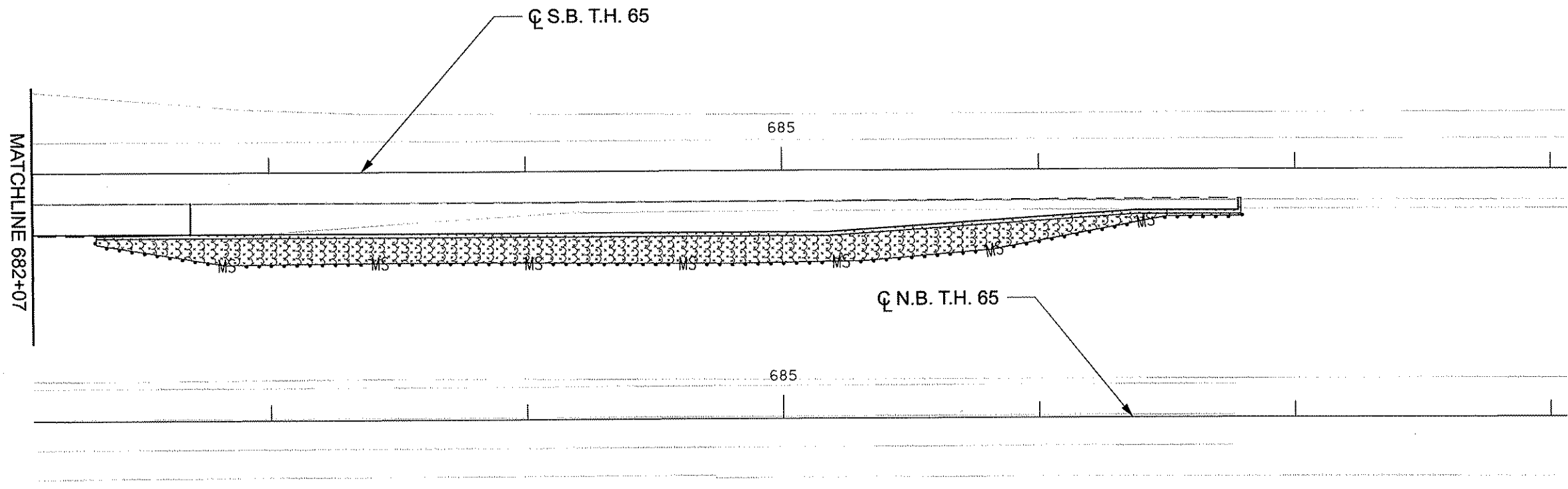

LEGEND	
	INLET PROTECTION
	FILTER LOG TYPE
	ROCK LOG
	SILT FENCE TYPE
	MACHINE SLICED
	FLOW DIRECTION
	CONSTRUCTION LIMIT
	SEEDING
	EROSION CONTROL BLANKET CATEGORY 0
	SODDING TYPE SALT RESISTANT

- GENERAL NOTES:
- 1.) SILT FENCE SHALL FOLLOW AS CLOSE AS POSSIBLE A SINGLE CONTOUR.
  - 2.) SILT FENCE SHALL BE CLEANED OUT OR REPLACED WHEN SEDIMENT REACHES 8" OR 1/3 OF SILT FENCE HEIGHT.
  - 3.) IF SILT DEPOSITS IN THE ANOKA COUNTY RIGHT OF WAY, THE CONTRACTOR IS RESPONSIBLE FOR ITS REMOVAL.
  - 4.) ALL GRADED AREAS ARE TO BE REVEGETATED WITHIN 14 DAYS OF THE COMPLETION OF GRADING.

NO	DATE	BY	CKD	APPR	REVISION
NAME: p:\116-65\plan\116-65_EC_P3.dgn					
06/06/2012 12:46:48 PM					

I HEREBY CERTIFY THAT THIS PLAN WAS PREPARED BY ME OR UNDER MY DIRECT SUPERVISION AND THAT I AM A DULY LICENSED PROFESSIONAL ENGINEER UNDER THE LAWS OF THE STATE OF MINNESOTA.

PRINT NAME: Curt Kobilanscik  
 SIGNATURE: *Curt Kobilanscik*  
 DATE: 6-7-12 LICENSE NO. 24756

DRAWN BY BAV DATE 3-23-12  
 DESIGN BY BAV DATE 3-23-12  
 CHECKED BY JEO DATE 4-10-12



S.P. 0208-145 (T.H. 65)  
 S.A.P. 002-716-013  
 S.A.P. 197-020-004

TURF ESTABLISHMENT AND EROSION CONTROL  
 STA 682+07 TO 686+79  
 Sheet 76 of 108 Sheets

PLOTTED/REVISED:  
 \$\$\$@DATE\$\$\$

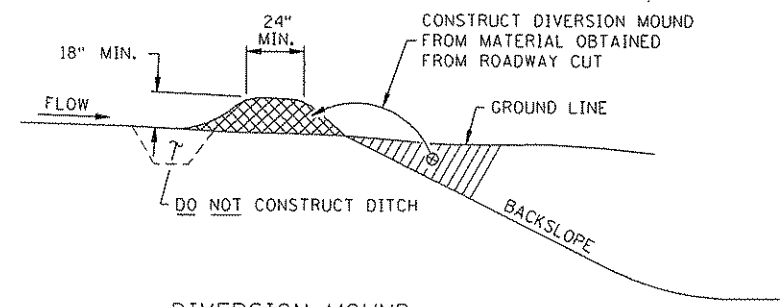

**DIVERSION MOUND**  
 DESIGN GUIDELINES:  
 STORM FREQUENCY: 10 YEAR - 24 HOUR  
 MAXIMUM DRAINAGE AREA: 5 ACRES  
 MAXIMUM DIVERSION: GRADE 5%

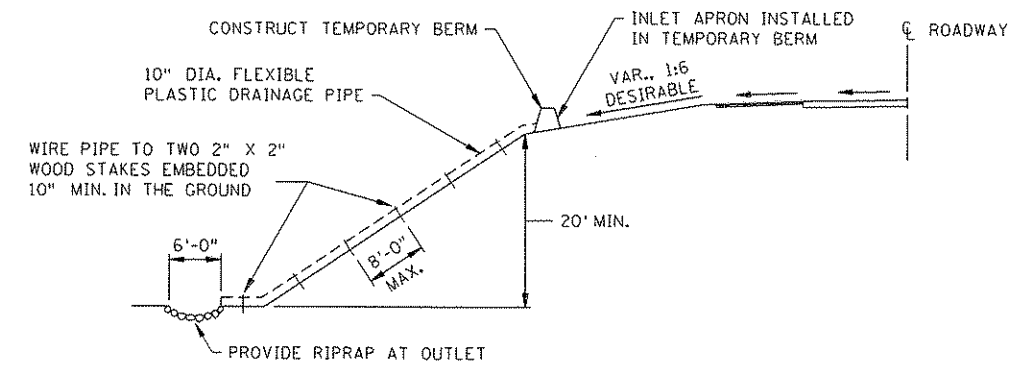

**TEMPORARY DOWN DRAIN ON FILL SLOPE**

DESIGN GUIDELINES:  
 STORM FREQUENCY: 2 YEAR - 24 HOUR  
 MAXIMUM DRAINAGE AREA: 3 ACRES

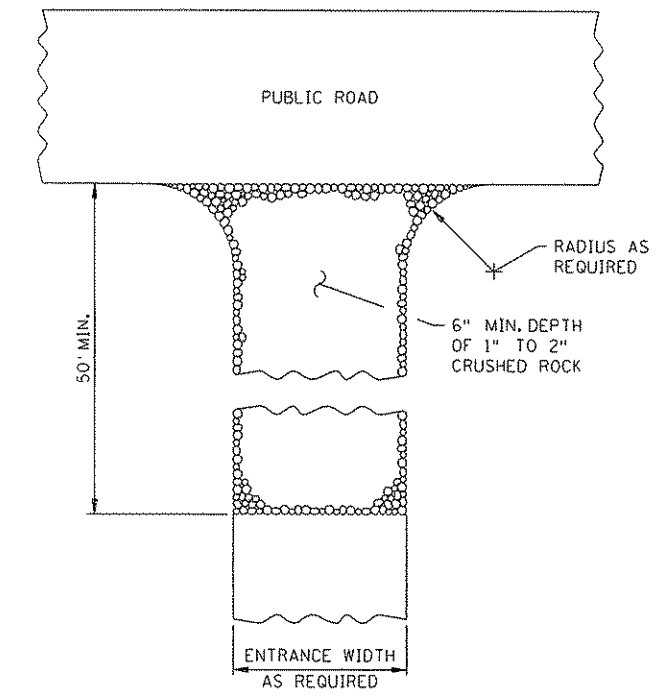

**ROCK CONSTRUCTION ENTRANCE ①**

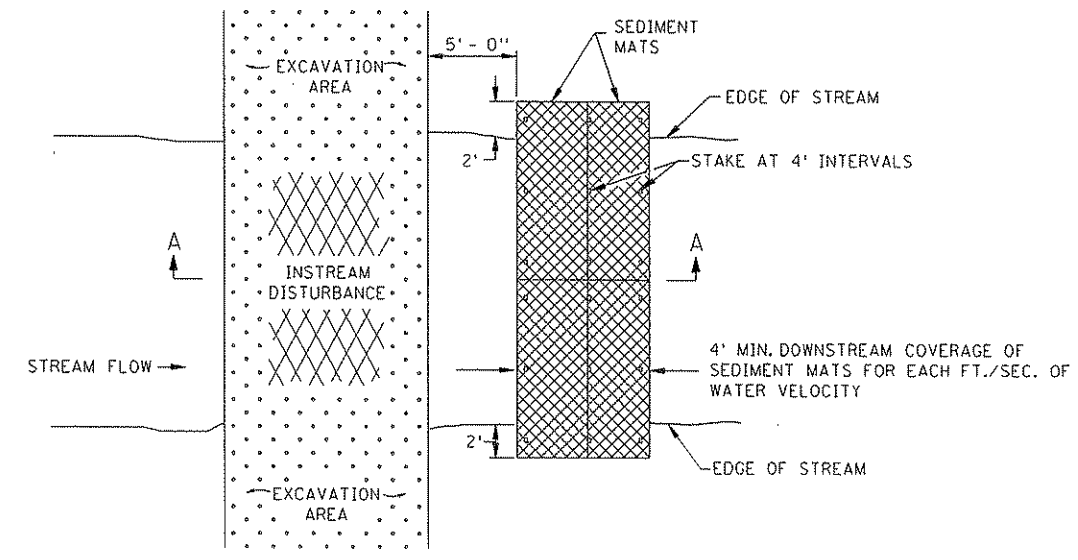

**PLAN VIEW**

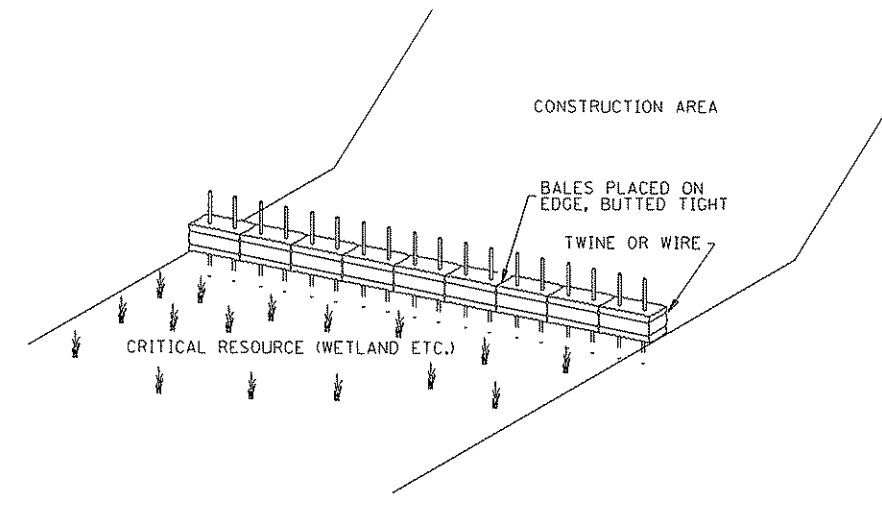

**BALE BARRIERS**

TO BE USED FOR CRITICAL PERIMETER CONTROL AREAS

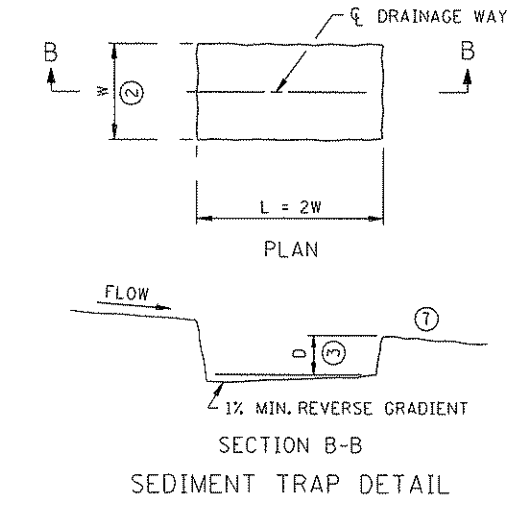

**SECTION B-B  
 SEDIMENT TRAP DETAIL**

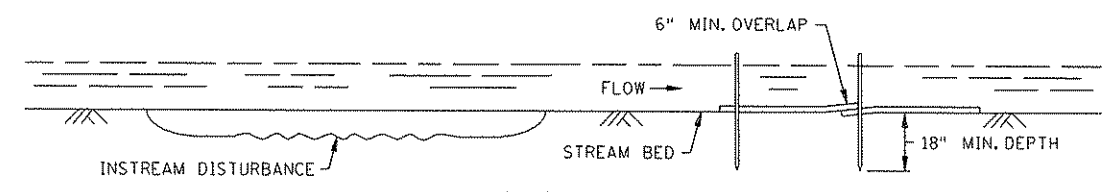

**SECTION A-A**

**SEDIMENT MAT ⑥  
 TYPICAL STREAM BED INSTALLATION**

DESIGN GUIDELINES:  
 MAXIMUM FLOW VELOCITY: 5 FT./SEC.  
 MAXIMUM FLOW DEPTH: 2 FT.

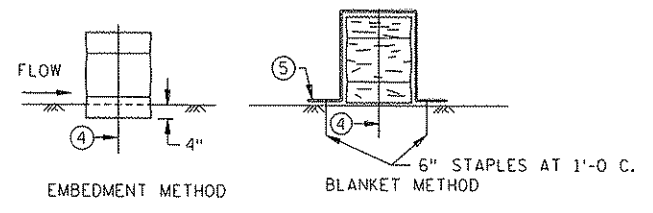

**BALE BARRIER DETAIL  
 APPROX. BALE SIZE: 14" X 18" X 36" LONG**

**NOTES:**

- SEE SPECS. 2573, 3892, & 3894.
- ① ROCKS AT ENTRANCE CLEAN WORKSITE MUD OFF OF TRUCK TIRES BEFORE TRUCKS ENTER MAIN ROAD. KEEPING MUD OFF THE ROAD WILL PREVENT AUTO DAMAGE AND KEEP CONSTRUCTION SEDIMENT OUT OF DRAINAGE SYSTEMS AND WETLANDS. GEOTEXTILE MAY BE PLACED UNDER THE ROCK TO KEEP ROCKS SEPARATE FROM SOIL.
- ② W = 10 FT. MIN., 20 FT. MAX.
- ③ D = 2 FT.
- ④ TWO 2 IN. X 2 IN. WOOD STAKES OR REINFORCING BARS IN EACH BALE EMBEDDED 10 INCHES MINIMUM IN THE GROUND.
- ⑤ PLACE A CATEGORY 3 EROSION CONTROL BLANKET, 6 FT. WIDE MINIMUM, OVER THE BALE INSTEAD OF TRENCHING.
- ⑥ THIS DETAIL MAY NOT BE ACCEPTABLE FOR WORK ON PUBLIC WATERS, SEE GENERAL PUBLIC WATERS PERMIT (GP) 2004-0001.
- ⑦ LOCATION OF DOWNSTREAM TEMPORARY SEDIMENT CONTROL DEVICE.

DISTRICT #: \$@DISTRICT\$  
 USER NAME: \$@USER\$NAME\$  
 PATH & FILENAME: \$\$\$@PATH\$FILENAME\$\$\$  
 FILE NAME: @FILENAME@

STANDARD SHEET NO. 5-297.405 ( 2 OF 4 )	TITLE: TEMPORARY SEDIMENT CONTROL MISCELLANEOUS DETAILS
STANDARD APPROVED: MARCH 29, 2012	
S.A.P. 002-716-013	S.P. 0208-145 (T.H. 85) S.A.P. 197-020-004 SHEET NO. 77 OF 108 SHEETS

PLOTTED/REVISED:  
\$\$\$\$\$DATE\$\$\$\$\$

DISTRICT #: \$@DISTRICT@  
USER NAME: \$@USER@NAME@  
PATH & FILENAME: \$\$\$@PATH@FILENAME@\$\$\$

FILE NAME:  
@FILENAME@

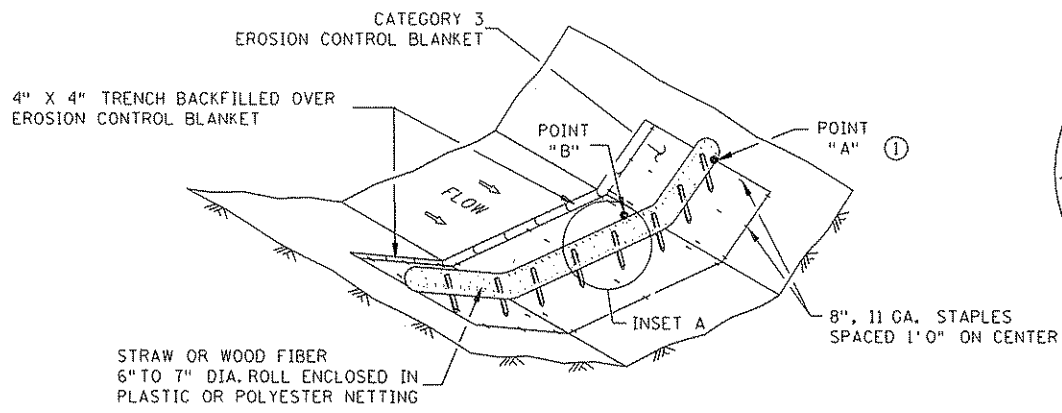

TYPE 3: BIOROLL BLANKET SYSTEM DITCH CHECK

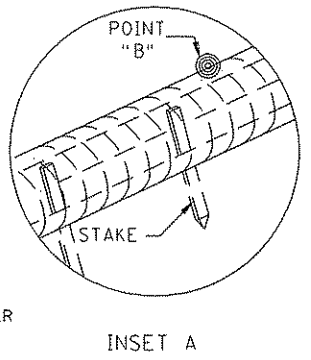

INSET A

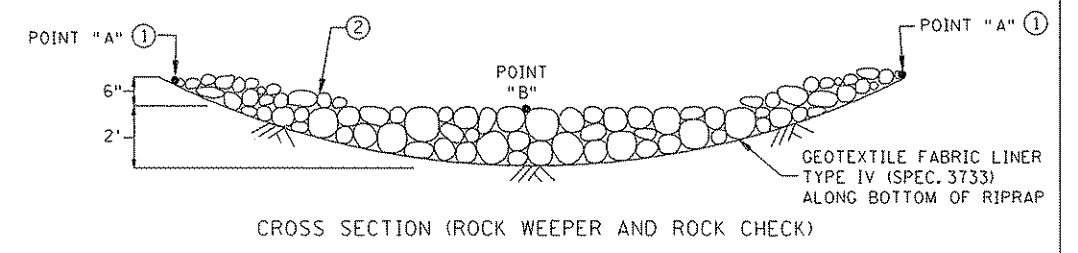

CROSS SECTION (ROCK WEEPER AND ROCK CHECK)

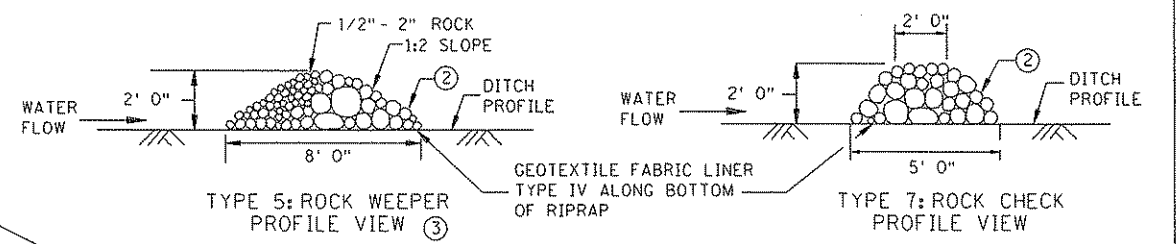

TYPE 5: ROCK WEEPER PROFILE VIEW

TYPE 7: ROCK CHECK PROFILE VIEW

TYPE 5: ROCK WEEPER AND TYPE 7: ROCK CHECK DITCH CHECKS  
USE ON ROUGH GRADED AREAS

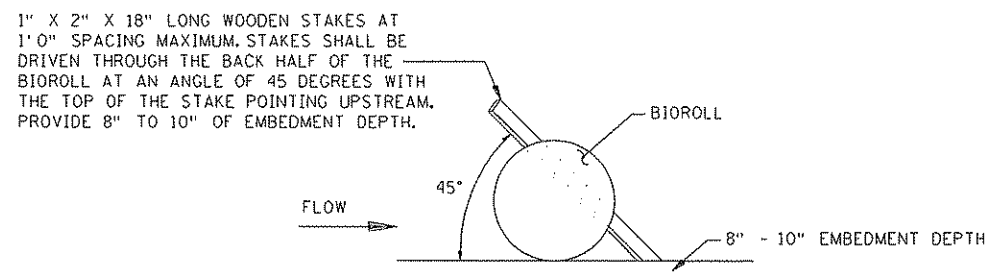

BIOROLL STAKING DETAIL

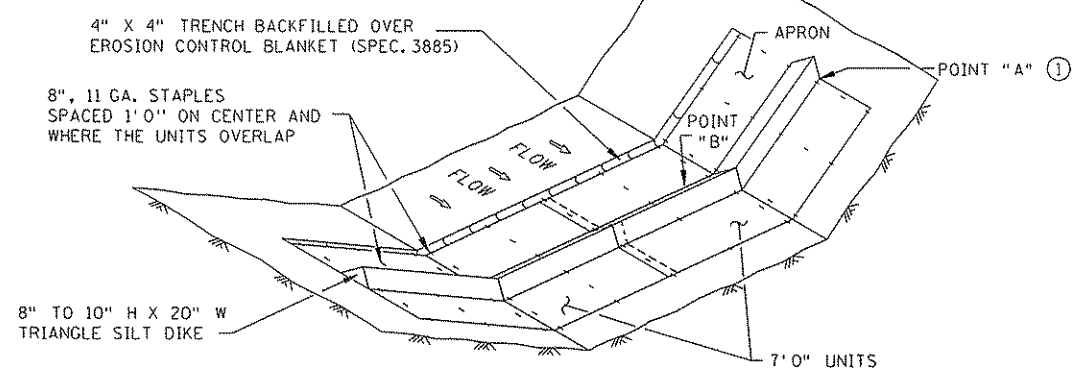

TYPE 6: GEOTEXTILE TRIANGULAR DIKE DITCH CHECK

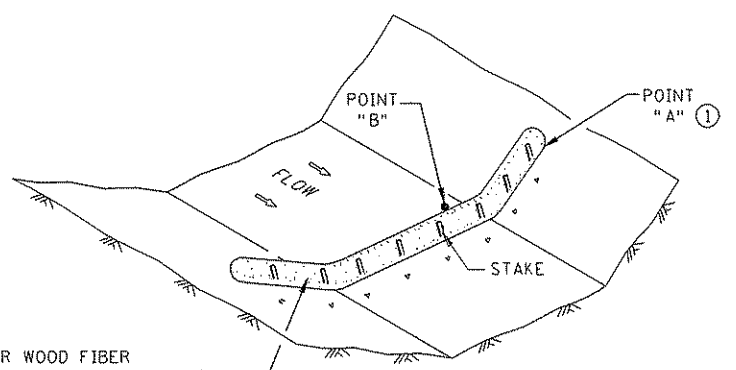

TYPE 2: BIOROLL DITCH CHECK  
USE ON ROUGH GRADED AREAS

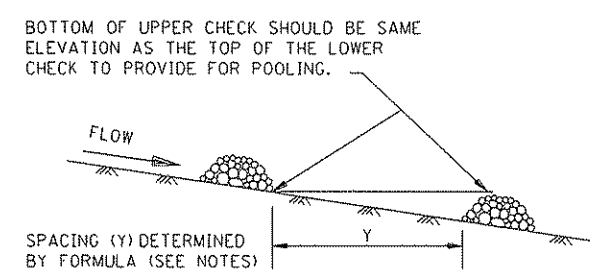

DITCH CHECK SPACING

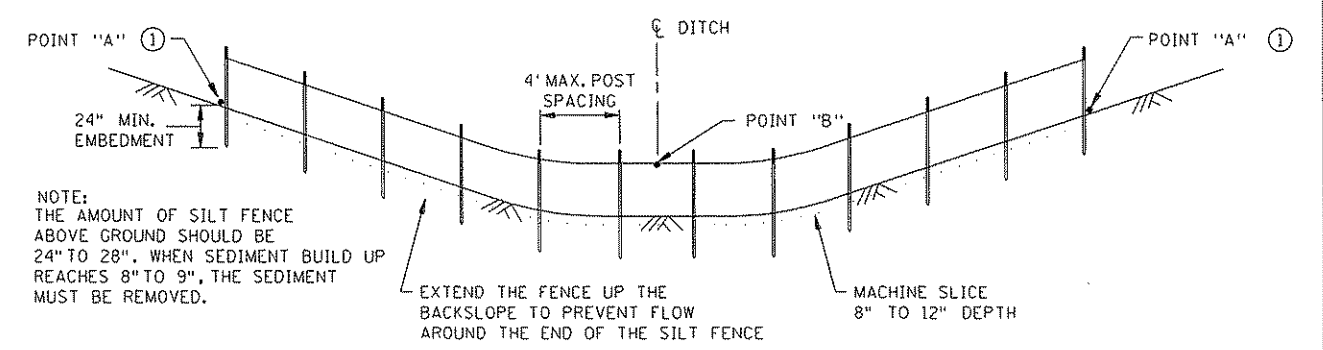

TYPE 1: SLICED IN SILT FENCE DITCH CHECK

- NOTES:
- SEE SPECS. 2573, 3601, 3733, 3885, 3886 & 3889.
  - APPROXIMATE SPACING BETWEEN EACH DITCH CHECK SHOULD BE DETERMINED FROM THE FOLLOWING SPACING FORMULA:  

$$\text{APPROXIMATE SPACING OF DITCH CHECKS (FT.)} = Y = \frac{\text{DITCH CHECK HEIGHT (FT)}}{\% \text{ CHANNEL SLOPE}} \times 100$$
  - ① POINT "A" MUST BE A MINIMUM OF 6 INCHES HIGHER THAN POINT "B" TO ENSURE THAT WATER FLOWS OVER THE DIKE AND NOT AROUND THE ENDS.
  - ② CLASS I - IV RIPRAP (SPEC. 3601) WITH GEOTEXTILE FABRIC LINER, TYPE IV (SPEC. 3733).
  - ③ THE ROCK WEEPER FILTERS SEDIMENT OUT OF THE WATER BETTER THAN THE OTHER DITCH CHECKS. THE ROCK WEEPER COULD BE USED AS A PERMANENT WATER FILTERING FEATURE.
  - ④ PERMANENT ROCK DITCH CHECKS PLACED WITHIN THE CLEAR ZONE WILL NEED TO BE 18" OR LESS IN HEIGHT. A 1:6 APPROACH AND DEPARTURE SLOPE SHALL BE PROVIDED.

GENERAL DESIGN GUIDELINES						
DITCH CHECK TYPE	SILT FENCE	BIOROLL	BIOROLL BLANKET	TRIANGULAR DIKE	ROCK WEEPER	ROCK CHECK
STORM FREQUENCY:	2 YR. - 24 HR.	2 YR. - 24 HR.	2 YR. - 24 HR.	2 YR. - 24 HR.	5 YR. - 24 HR.	5 YR. - 24 HR.
MAX. FLOW VELOCITY:	< 1 FT./SECOND	1.5 FT./SECOND	4.5 FT./SECOND	1.5 FT./SECOND	12 FT./SECOND	12 FT./SECOND
MAX. DITCH GRADE:	0% - 0.5%	1.5% - 3%	1.5% - 3%	1.5% - 2.0%	3% - 5%	3% - 5%
MAX. DRAINAGE AREA:	1 ACRE	2 ACRE	2 ACRE	4 ACRE	4+ ACRE	4+ ACRE

PLOTTED/REVISED:  
\$\$\$\$DATE\$\$\$\$

DISTRICT #: \$@DISTRICT@  
USER NAME: \$@USER@  
PATH & FILENAME: \$@PATH@FILENAME@

FILE NAME:  
@FILENAME@

INLET SPECIFICATIONS AS PER THE PLAN  
DIMENSION LENGTH AND WIDTH TO MATCH  
FLAP POCKET

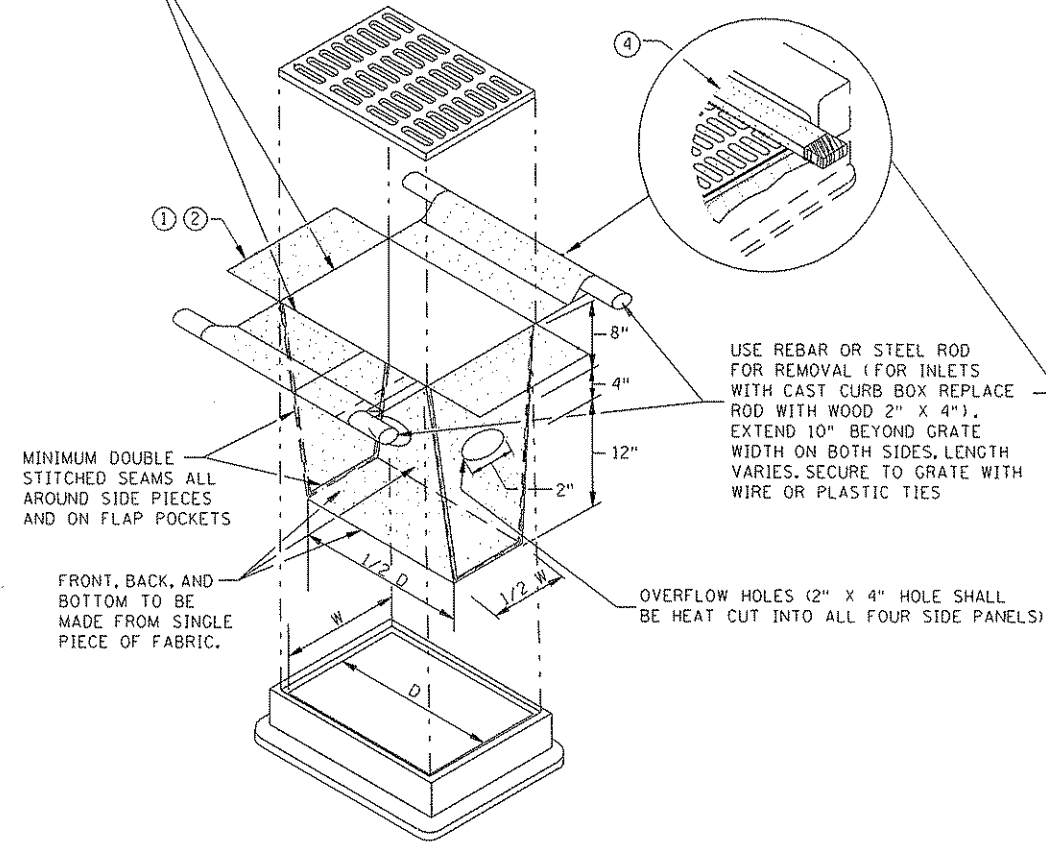

**FILTER BAG INSERT ③**

(CAN BE INSTALLED IN ANY INLET TYPE  
WITH OR WITHOUT A CURB BOX)

ENDS SECURELY CLOSED TO  
PREVENT LOSS OF OPEN GRADED  
AGGREGATE FILL. SECURED WITH  
50 PSI. ZIP TIE.

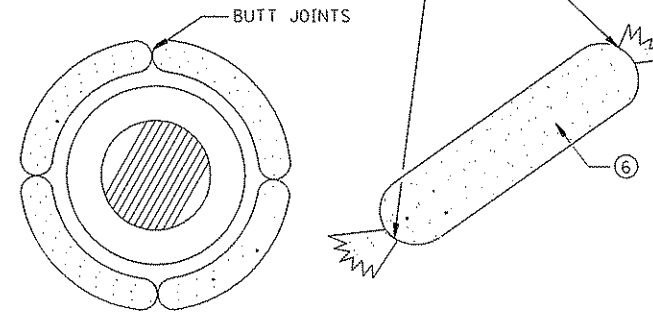

**ROCK LOG/COMPOST LOG**

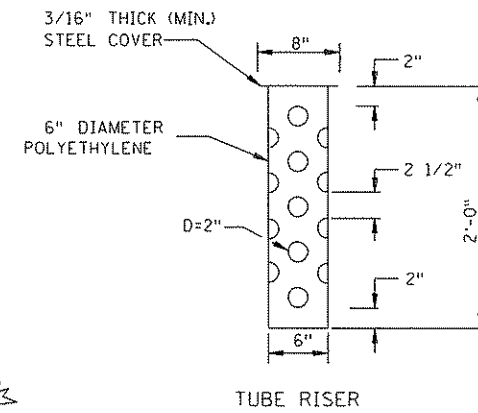

**TUBE RISER**

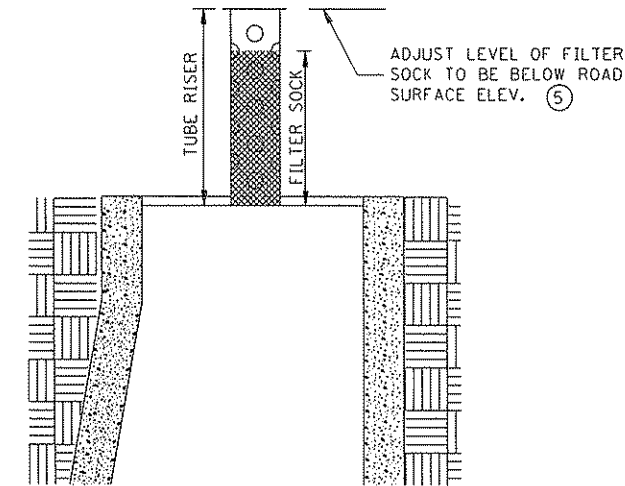

**SECTION  
(UP POSITION)**

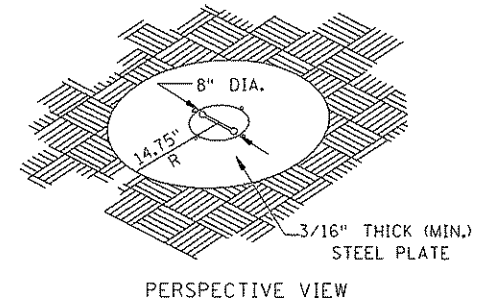

**PERSPECTIVE VIEW**

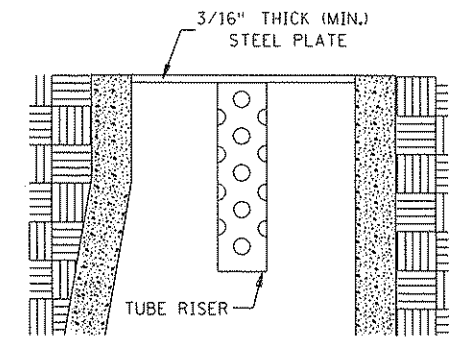

**SECTION  
(DOWN POSITION)**

**POP-UP HEAD**

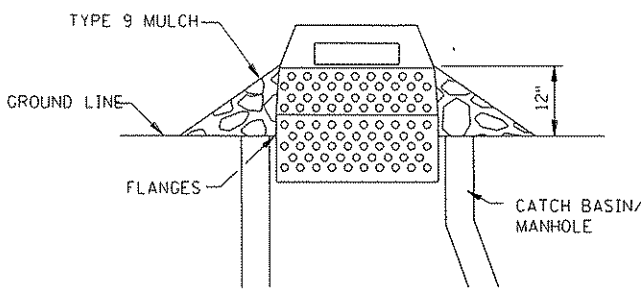

**SEDIMENT CONTROL INLET HAT**

NOTE:  
THE SEDIMENT CONTROL BARRIER SHALL BE A METAL  
OR PLASTIC/POLYETHYLENE RISER SIZED TO FIT INSIDE  
THE CATCH BASIN/MANHOLE; HAVE PERFORATIONS TO ALLOW  
FOR WATER INFILTRATION; HAVE AN OVERFLOW OPENING,  
FLANGES AND A LID/COVER.

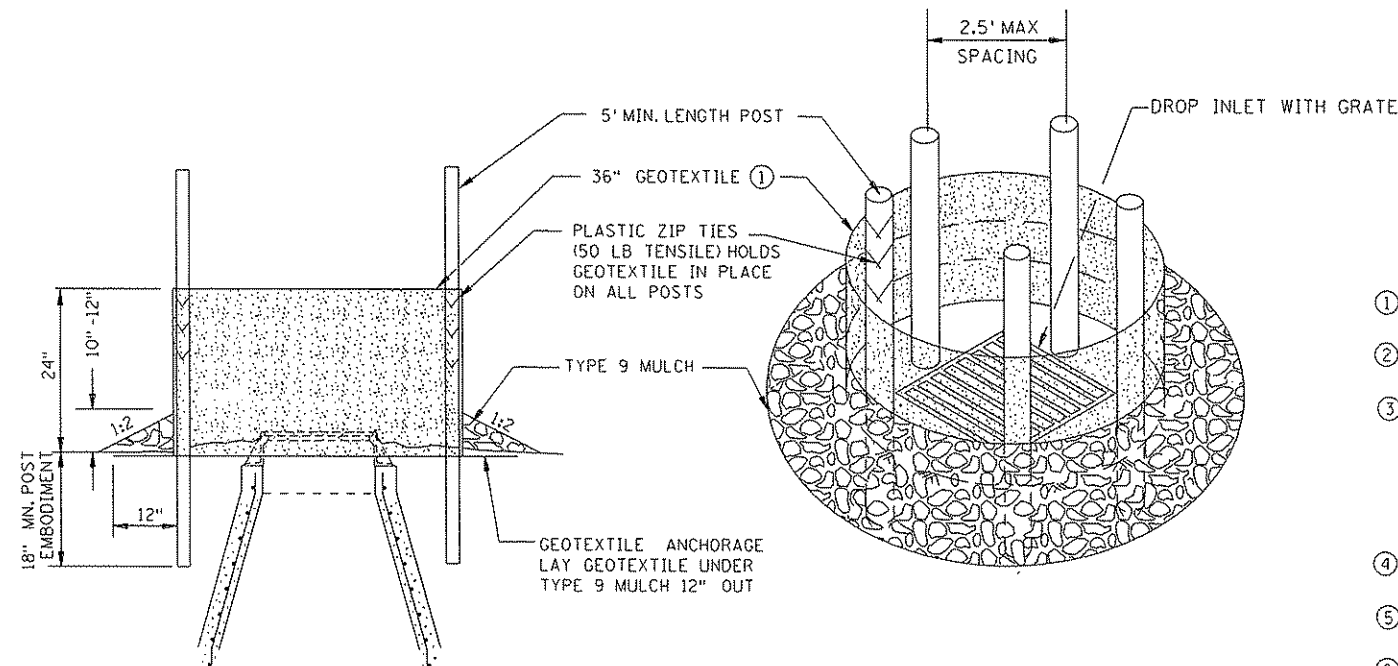

**SILT FENCE RING AND ROCK FILTER BERM**  
USE WHERE INLET DRAINS IN AN AREA WITH SLOPES AT 1:3 OR LESS

NOTES:  
SEE SPECS. 2573, 3137, 3886 & 3891.

MANUFACTURED ALTERNATIVES LISTED ON Mn/DOT'S APPROVED PRODUCTS LIST  
MAY BE SUBSTITUTED.

- ① ALL GEOTEXTILE USED FOR INLET PROTECTION SHALL BE MONOFILAMENT IN BOTH DIRECTIONS, MEETING SPEC. 3886.
- ② FINISHED SIZE, INCLUDING POCKETS WHERE REQUIRED SHALL EXTEND A MINIMUM OF 10 INCHES AROUND THE PERIMETER TO FACILITATE MAINTENANCE OR REMOVAL.
- ③ INSTALLATION NOTES:  
DO NOT INSTALL FILTER BAG INSERT IN INLETS SHALLOWER THAN 30 INCHES, MEASURED FROM THE BOTTOM OF THE INLET TO THE TOP OF THE GRATE. THE INSTALLED BAG SHALL HAVE A MINIMUM SIDE CLEARANCE OF 3 INCHES BETWEEN THE INLET WALLS AND THE BAG, MEASURED AT THE BOTTOM OF THE OVERFLOW HOLES. WHERE NECESSARY THE CONTRACTOR SHALL CLINCH THE BAG, USING PLASTIC ZIP TIES, TO ACHIEVE THE 3 INCH SIDE CLEARANCE.
- ④ FLAP POCKETS SHALL BE LARGE ENOUGH TO ACCEPT WOOD 2 INCH X 4 INCH OR USE A ROCK SOCK OR SAND BAGS IN PLACE OF THE FLAP POCKETS.
- ⑤ SOCK HEIGHT MUST NOT BE SO HIGH AS TO SLOW DOWN WATER FILTRATION TO CAUSE FLOODING OF THE ROADWAY.
- ⑥ GEOTEXTILE SOCK BETWEEN 4-10 FEET LONG AND 4-6 INCH DIAMETER. SEAM TO BE JOINED BY TWO ROWS OF STITCHING WITH A PLASTIC MESH BACKING OR PROVIDE A HEAT BONDED SEAM (OR APPROVED EQUIVALENT). FILL ROCK LOG WITH OPEN GRADED AGGREGATE CONSISTING OF SOUND DURABLE PARTICLES OF COARSE AGGREGATE CONFORMING TO SPEC. 3137 TABLE 3137-1; CA-3 GRADATION.

STANDARD SHEET NO.  
297.405 (4 OF 4)  
STANDARD APPROVED:  
MARCH 29, 2012

TITLE:

TEMPORARY SEDIMENT CONTROL  
STORM DRAIN INLET PROTECTION

S.A.P. 002-716-013

S.P. 0208-145 (T.H. 65)

S.A.P. 197-020-004

SHEET NO. 79 OF 108 SHEETS

PLOTTED/REVISED:  
 \$\$\$@DATE@\$\$\$

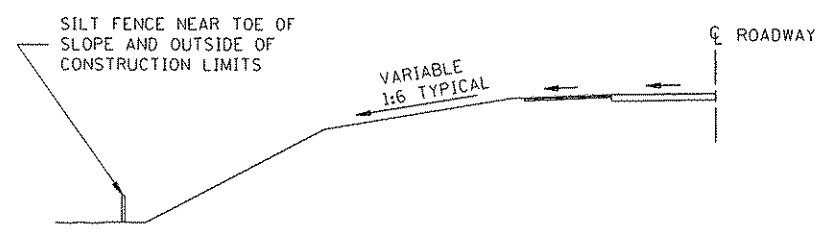

LOCATION OF SILT FENCE  
 AT TOE OF ROADWAY EMBANKMENT

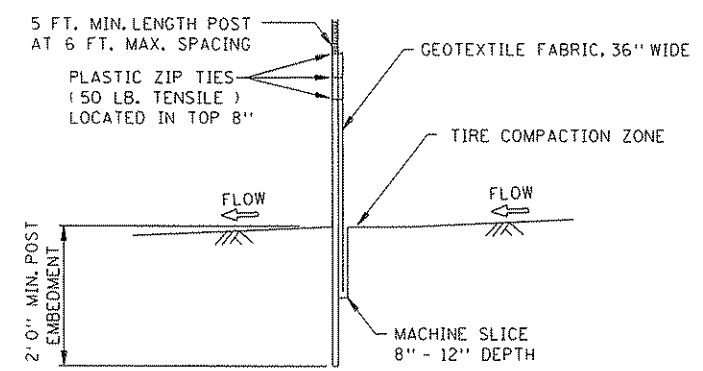

SILT FENCE, MACHINE SLICED  
 DESIGN GUIDELINES:  
 TO PROTECT AREAS FROM SHEET FLOW.  
 MAXIMUM CONTRIBUTING AREA: 1 ACRE.

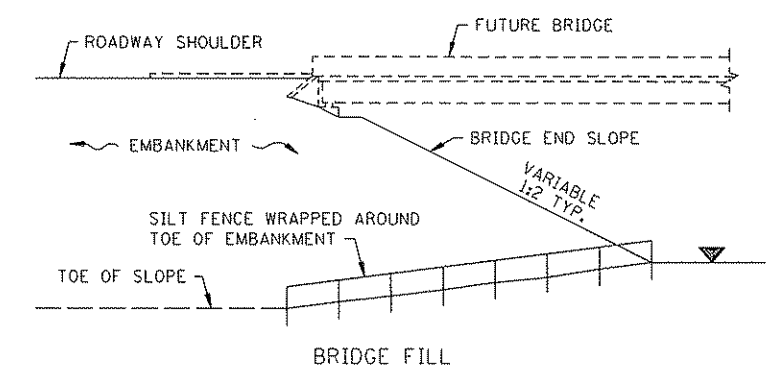

DESIGN GUIDELINES:  
 WATER COURSE FLOW VELOCITY: STAGNANT  
 CONTRIBUTING SLOPE AREA: 1/2 ACRE

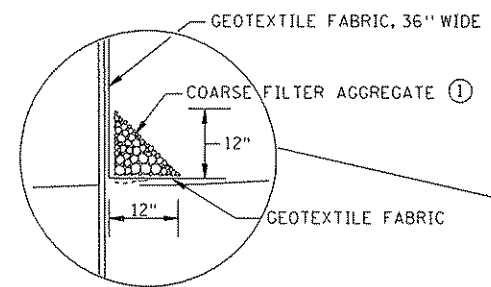

OPTIONAL METHOD  
 FOR SILT FENCE, HEAVY DUTY

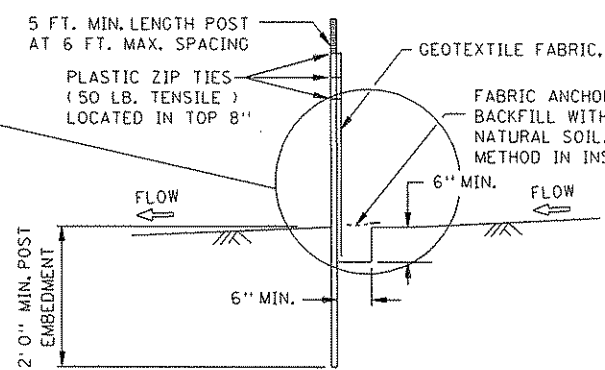

SILT FENCE, HEAVY DUTY  
 (HAND INSTALLED)  
 DESIGN GUIDELINES:  
 TO PROTECT AREAS FROM SHEET FLOW.  
 MAXIMUM CONTRIBUTING AREA: 1 ACRE.

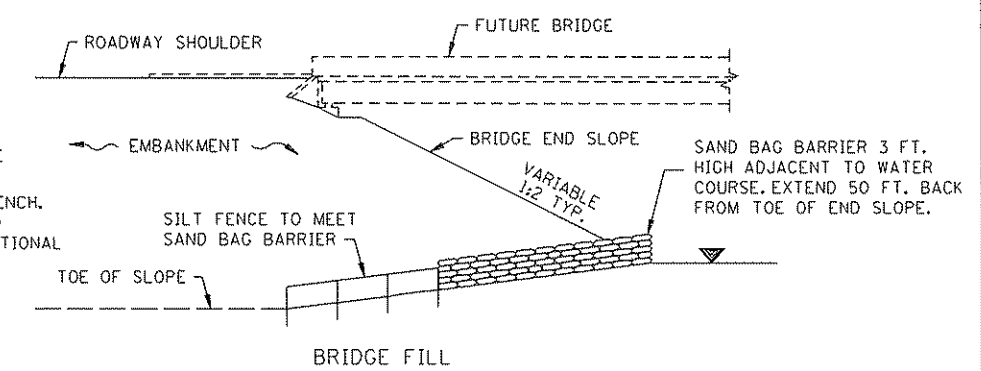

DESIGN GUIDELINES:  
 WATER COURSE FLOW VELOCITY: 1 TO 7 FT./SEC.  
 CONTRIBUTING SLOPE AREA: 1 ACRE

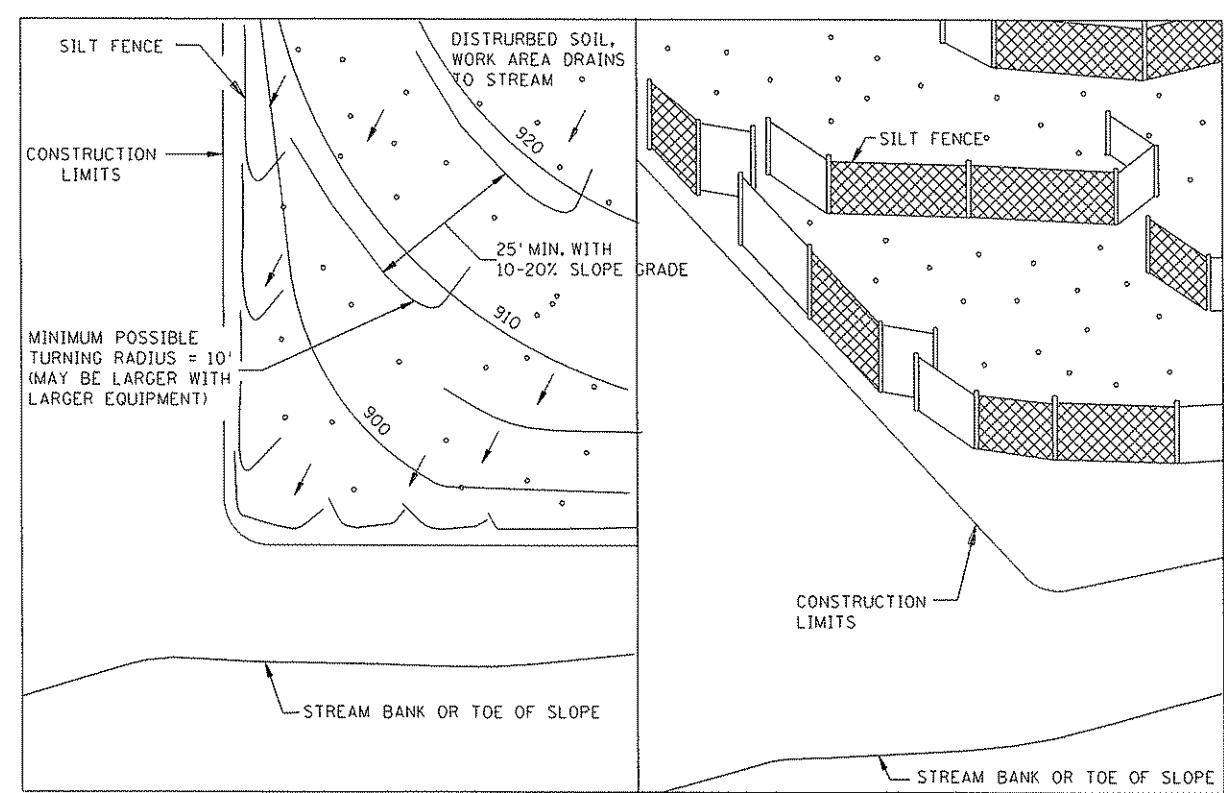

PLAN VIEW  
 SIDE VIEW  
 SILT FENCE, J-HOOK INSTALLATION

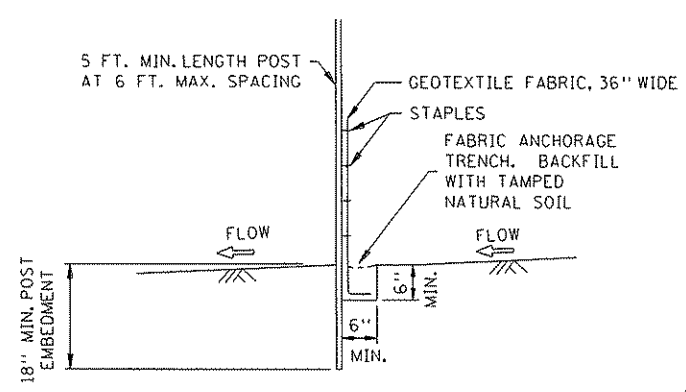

SILT FENCE, PREASSEMBLED  
 DESIGN GUIDELINES:  
 TO PROTECT AREAS FROM SHEET FLOW.  
 MAXIMUM CONTRIBUTING AREA: 1 ACRE.

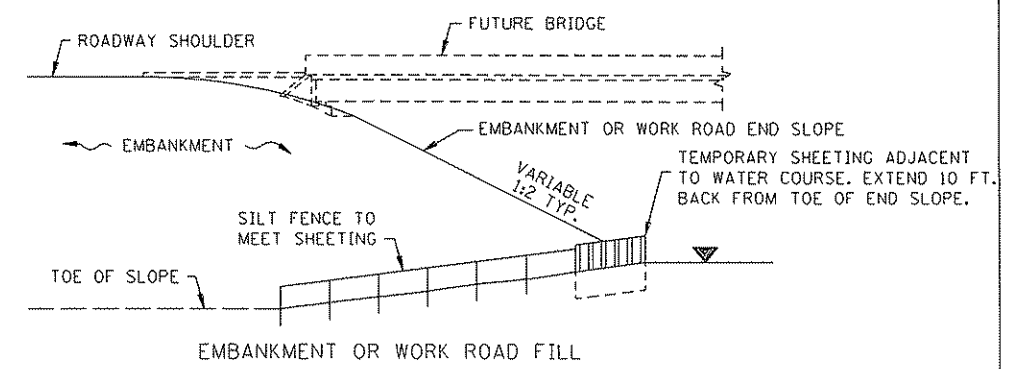

DESIGN GUIDELINES:  
 WATER COURSE FLOW VELOCITY: 8 TO 15 FT./SEC.  
 CONTRIBUTING SLOPE AREA: 3 ACRES  
 SILT FENCE AT BRIDGE EMBANKMENT ADJACENT TO WATER

NOTES:  
 SEE SPECS. 2573, 3149 & 3886.  
 ① COARSE FILTER AGGREGATE (SPEC. 3149) SHALL BE INCIDENTAL.

DISTRICT #: \$@DISTRICT@  
 USER NAME: \$@USER\$NAME@  
 PATH & FILENAME: \$\$\$@PATH@FILENAME@\$\$\$  
 FILE NAME:  
 @FILENAME@

STANDARD SHEET NO. 5-297,408 (1 OF 2)	TITLE: TEMPORARY SEDIMENT CONTROL SILT FENCE
STANDARD APPROVED: SEPTEMBER 27, 2006	
S.A.P. 002-716-013	S.P. 0208-145 (T.H. 65) S.A.P. 197-020-004 SHEET NO. 80 OF 108 SHEETS



ABBREVIATIONS	
APS	ACCESSIBLE PEDESTRIAN SIGNAL
AWF	ADVANCED WARNING FLASHER
BL	BLUE
BL/BLK	BLUE WITH BLACK TRACER
BLK	BLACK
BLK/R	BLACK WITH RED TRACER
BLK/WH	BLACK WITH WHITE TRACER
C.D.	COUNT DOWN
CH. SW.	CHECK SWITCH
CLR	CLEAR
D2-1 (e.g.)	DETECTOR (PHASE 2, NO. 1)
DEG	DEGREES
DWK	DON'T WALK
EQ.G	EQUIPMENT GROUND
EVP	EMERGENCY VEHICLE PRE-EMPTION
F&I	FURNISH AND INSTALL
FL	FLASH/FLASHING
FYA	FLASHING YELLOW ARROW
FYLA	FLASHING YELLOW LEFT ARROW
G	GREEN
G/BLK	GREEN WITH BLACK TRACER
GLA	GREEN LEFT ARROW
GRN	GREEN INDICATION
GR. RD.	GROUND ROD
GRA	GREEN RIGHT ARROW
GTA	GREEN THRU ARROW
HH	HANDHOLE
HPS	HIGH PRESSURE SODIUM
IMC	INTERMEDIATE METAL CONDUIT
IND	INDICATION
INP	INPLACE
INS. GR.	INSULATED GROUND
JB	JUNCTION BOX
LED	LIGHT EMITTING DIODE
LHT	LIGHT
LUM	LUMINAIRE
NEU	NEUTRAL
NMC	NONMETALLIC CONDUIT
O	ORANGE
O/BLK	ORANGE WITH BLACK TRACER
P1-1 (e.g.)	PEDESTRIAN INDICATION (PHASE 1, NO. 1)
PB	PUSH BUTTON
PB2-1 (e.g.)	PUSH BUTTON (PHASE 2, NO. 1)
PEC	PHOTOELECTRIC CELL
PED	PEDESTRIAN
PVC	POLYVINYL CHLORIDE (CONDUIT)
RED	RED INDICATION
R&S	REMOVE AND SALVAGE
R/BLK	RED WITH BLACK TRACER
RLA	RED LEFT ARROW
RSC	RIGID STEEL CONDUIT
S & I	SALVAGE AND INSTALL
SOP	SOURCE OF POWER
SPR	SPARE
ST LHT	STREET LIGHT
STA	STATION
SW	SWITCH
SWD	SWITCHED
TDW	TELEPHONE DROP WIRE
WH	WHITE
WH/BLK	WHITE WITH BLACK TRACER
WH/R	WHITE WITH RED TRACER
WLK	WALK
YEL	YELLOW INDICATION
YLA	YELLOW LEFT ARROW
YRA	YELLOW RIGHT ARROW

SYMBOLS	
	HANDHOLE
	EQ. G CONNECTION
	EVP CONFIRMATORY LIGHT
	EVP DETECTOR
	EVP DETECTOR & CONFIRMATORY LIGHT
	FIBER OPTIC VAULT
	LUMINAIRE NO.
	SIGNAL BASE NO.
	SIGNAL FACE NO./FLASHER FACE NO.
	SPLICE
	VIDEO DETECTION
	MICROWAVE DETECTION
	SONIC DETECTION

FOR PLANS AND UTILITIES SYMBOLS  
SEE TECHNICAL MANUAL

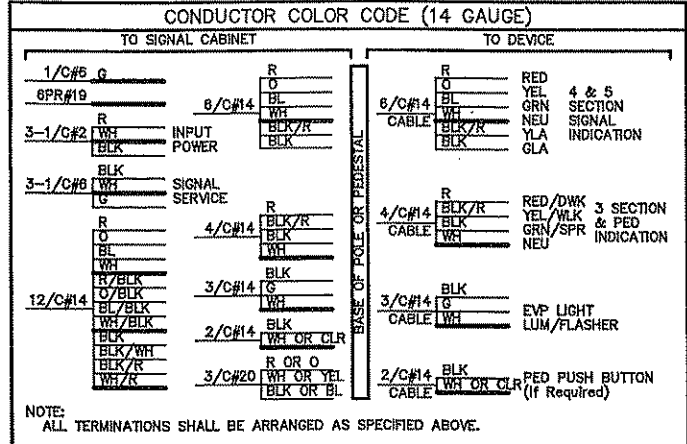

TABULATION OF SIGNAL QUANTITIES			
ITEM NO	ITEM	UNIT	TOTAL ESTIMATED QUANTITY
2565	REVISE SIGNAL SYSTEM	SYSTEM	1

SIGNS FOR TRAFFIC SIGNAL SYSTEM									
SIGN PANELS - TYPE C (SIGNALS) (F & I)									
SIGN PANEL	POLE NO.	a (FT)	b (FT)	SIZE (IN)	MOUNTING BRACKET		AREA/SIGN (SQ. FT.)	NO. REQ.	PANEL LEGEND
					QUANTITY	SPACING (1)			
R10-X12	2	1'	—	36 x 42	2	—	10.50	1	Left Turn Yield on Flashing Yellow Arrow
R10-X12	5	1'	—	36 x 42	2	—	10.50	1	Left Turn Yield on Flashing Yellow Arrow
TOTAL QUANTITIES							21.00	2	

SIGNS FOR TRAFFIC SIGNAL SYSTEM									
SIGN PANELS - TYPE D (SIGNALS) (F & I)									
SIGN PANEL	POLE NO.	a (FT)	b (FT)	SIZE (IN)	MOUNTING BRACKET		AREA/SIGN (SQ. FT.)	NO. REQ.	PANEL LEGEND
					QUANTITY	SPACING (1)			
D-1	1	—	20'	150 x 24	5	—	25.00	1	Bunker Lake Blvd NE
D-2	2	—	8'	36 x 48	2	—	12.00	1	TH 65 w/Double Arrow
D-3	4	—	20'	150 x 24	5	—	25.00	1	Bunker Lake Blvd NE
D-4	5	—	15'	36 x 48	2	—	12.00	1	TH 65 w/Double Arrow
TOTAL QUANTITIES							74.00	4	

(1) = SPACING BETWEEN STIFFENERS SHALL NOT EXCEED 36 INCHES AND SHALL BE UNIFORMLY SPACED. SEE STANDARD SIGNS MANUAL, PAGE 105A (REVISION DATE 7/06/2007) FOR BRACKET SPACING REQUIREMENTS.

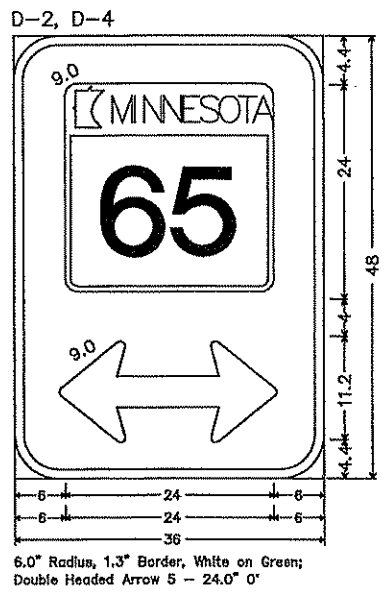

OVERLAYS				
CODE NO.	QUANTITY	SIZE (in.)	LEGEND	SQ.FT. PER OVERLAY
M1-5B	2	24x24	MN. HWY 65	4.00

- SIGNING NOTES:
- 1) CORNERS EXTENDING BEYOND THE BORDER SHALL NOT BE TRIMMED. CORNERS OF STANDARD SIGN PANELS WITH MARGINS SHALL BE TRIMMED.
  - 2) FURNISHING AND INSTALLING TYPE C AND TYPE D SIGNS SHALL BE INCLUDED AS PART OF PAY ITEM FOR "REVISE SIGNAL SYSTEM" (ITEM NO. 2565), WITH NO DIRECT COMPENSATION BEING MADE THEREFORE.
  - 3) ALL NEW TYPE C AND TYPE D SIGN PANELS SHALL BE FABRICATED USING DG3 SHEETING. SEE SPECIAL PROVISIONS.
  - 4) SEE STANDARD SIGNS MANUAL FOR ARROW AND OVERLAY DETAILS. (ALL ARROWS SHALL BE SOLID FILLED-IN ARROWS).

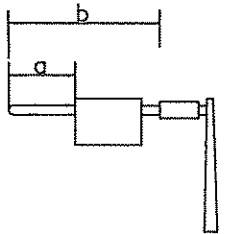
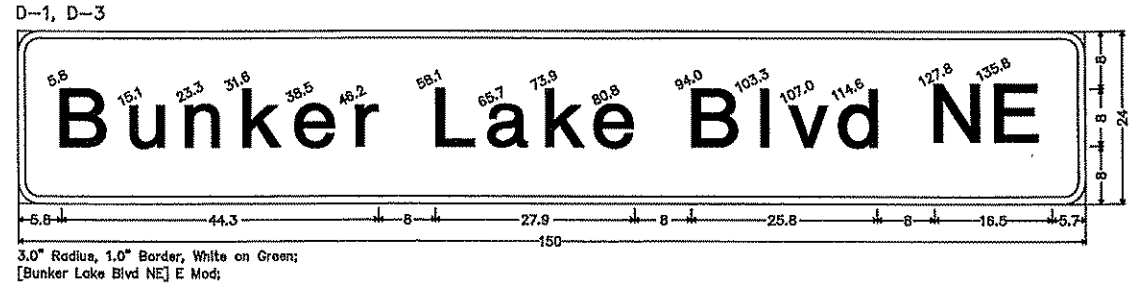

STANDARD PLATES - SIGNAL SYSTEMS			
THE FOLLOWING STANDARD PLATES, APPROVED BY THE FEDERAL HIGHWAY ADMINISTRATION, SHALL APPLY ON THIS PROJECT			
PLATE NO.	DESCRIPTION	PLATE NO.	DESCRIPTION
▶ 8000 I	STANDARD BARRICADES	▶ 8122 F	PEDESTAL & PEDESTAL BASE (FOR TRAFFIC CONTROL SIGNALS SUPPORT)
▶ 8110 E	TRAFFIC SIGNAL BRACKETING (POLE MOUNTED)	▶ 8123 G	POLE & MAST ARM-LUMINAIRE & TRAFFIC LIGHTS ASSEMBLY (2 SHEETS)
▶ 8111 E	TRAFFIC SIGNAL BRACKETING (PEDESTAL MOUNTED) (3 SHEETS)	▶ 8132 B	PREFORMED RIGID PVC CONDUIT LOOP DETECTOR (3 SHEETS)
▶ 8112 G	PEDESTAL FOUNDATION (TRAFFIC CONTROL SIGNALS)		
▶ 8114 A	PVC HANDHOLE/PULLBOX (NO VEHICLE LOAD) (2 SHEETS)		
▶ 8120 P	POLE FOUNDATION (PA 85)		
▶ 8121 G	TRANSFORMER BASE & POLE BASE PLATE (2 SHEETS)		

▶ = STANDARD PLATE APPLIES TO THIS PROJECT.

SIGNAL SYSTEMS PLAN INDEX	
SHEET NO.	DESCRIPTION
SG1	DETAILS AND STANDARD PLATES
SG2 - SG3	TRAFFIC SIGNAL DETAILS
SG4 - SG6	INTERSECTION LAYOUT
SG7	FIELD WIRING DIAGRAM
SG8-SG10	"FOR INFORMATION ONLY"

System ID = 21180  
TE # = 5610  
Meter Address = 13701 Hwy 65.

S.P. 0208-145  
S.A.P. 002-716-013  
S.A.P. 197-020-004

DRAWN BY: JMG  
DESIGNER: JMG  
CHECKED BY: JMG

DESIGN TEAM	NO.	BY	DATE	REVISIONS

I HEREBY CERTIFY THAT THIS PLAN WAS PREPARED BY ME OR UNDER MY DIRECT SUPERVISION AND THAT I AM A DULY LICENSED PROFESSIONAL ENGINEER UNDER THE LAWS OF THE STATE OF MINNESOTA.

*John M. Gray, PE*  
Name: John M. Gray, PE  
Lic. No. 22457  
Date: June 7, 2012

SEH  
PHONE: (651) 490-2000  
3535 VADNAIS CENTER DR.  
ST. PAUL, MN 55110

ANOKA COUNTY,  
MINNESOTA  
CITY OF HAM LAKE

REVISE SIGNAL SYSTEM  
INTERSECTION LAYOUT  
TRUNK HIGHWAY 65 AT CSAH 116

FILE NO.  
ANOKC 119012  
SIGNAL SHEET  
SG1 OF SG10  
81  
108

PEDESTRIAN PUSH BUTTON STATION

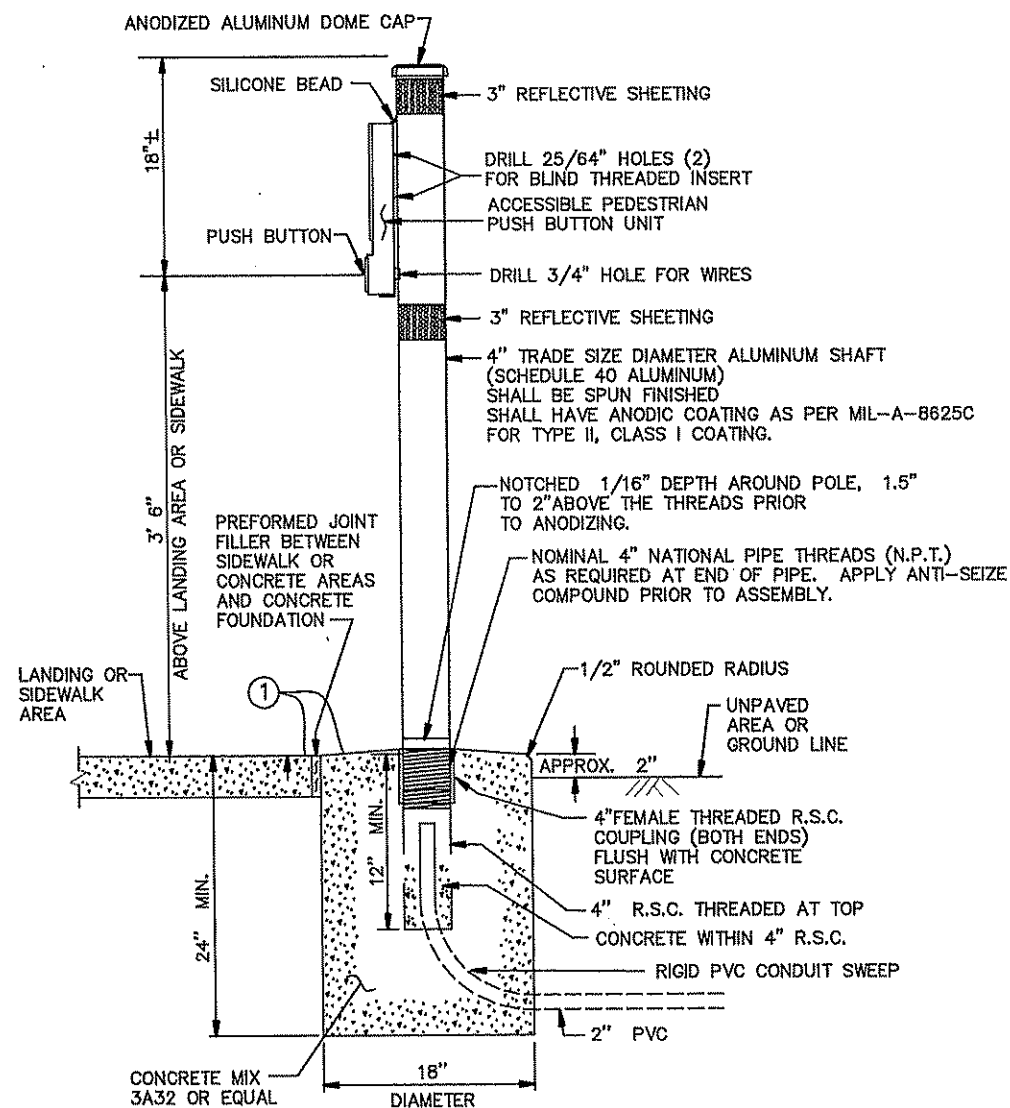

NOTES:

- PLACEMENT AND ORIENTATION OF THE PUSH BUTTON STATION IS CRITICAL. MOUNT THE BUTTON SO THAT THE FACE IS PARALLEL WITH THE ASSOCIATED CROSSWALK. SCREW IN POST TO A TIGHTENED POSITION BEFORE MOUNTING ACCESSIBLE PEDESTRIAN PUSH BUTTON UNIT TO THE POST.
  - BLIND THREADED INSERTS (RIVET NUT) MUST BE INSERTED USING MANUFACTURERS SPECIFIC INSTALLATION TOOL. NO OTHER METHOD OF INSTALLATION IS ACCEPTABLE.
  - BLIND THREADED INSERTS SHALL BE ZINC PLATED STEEL WITH 1/4 - 20 UNC THREADS. INSERT SHALL BE SUITABLE FOR USE ON A MOUNTING SURFACE WALL THICKNESS OF .337". APPROVED BLIND THREADED INSERTS CAN BE FOUND ON THE MN/DOT QUALIFIED PRODUCTS LIST.
  - MOUNTING BOLTS SHALL BE 1/4 - 20 STAINLESS STEEL. APPLY BRUSH ON ANTI SEIZE COMPOUND TO BOLTS PRIOR TO ASSEMBLY.
  - APPLY A BEAD OF 100% SILICONE SEALANT ALONG THE TOP OF THE PUSH BUTTON UNIT WHERE IT COMES IN CONTACT WITH THE 4" POST.
  - THE REFLECTIVE SHEETING SHALL BE WHITE AT INTERSECTION CORNERS AND SHALL BE YELLOW WHEN USED IN CENTER MEDIANS. SEE MN/DOT SIGNING QUALIFIED PRODUCTS LIST (QPL) FOR APPROVED SIGN SHEETING.
  - ANTI-SEIZE COMPOUND MUST BE USED ON THE MOUNTING BOLTS WHEN THE PEDESTRIAN SIGN IS MOUNTED.
- ① THE CONCRETE FOUNDATION SHALL BE CAST INPLACE AND CONSTRUCTED FLUSH WITH THE SURROUNDING SIDEWALK.

GUIDELINES FOR LOCATING APS PUSH BUTTONS:

- THIS IS A GENERAL DETAIL INTENDED TO SHOW THE REQUIREMENTS OF APS PUSH BUTTON LOCATION. FOR PROJECT SPECIFIC DETAILS REGARDING PEDESTRIAN RAMP LAYOUT, SEE THE PEDESTRIAN CURB RAMP AND SIDEWALK DETAILS.
- BUTTONS SHALL BE WITHIN 5' OF THE OUTSIDE EDGE OF THE CROSSWALK.
- THE FACE OF THE BUTTON SHALL BE PARALLEL WITH THE CROSSWALK.
- A MIN. 4'X4' LANDING AREA SHALL BE PROVIDED ADJACENT TO EACH BUTTON.
- BUTTONS SHALL BE WITHIN 10' OF THE BACK OF CURB OR EDGE OF ROADWAY.
- BUTTONS SHALL BE AT LEAST 10' APART.

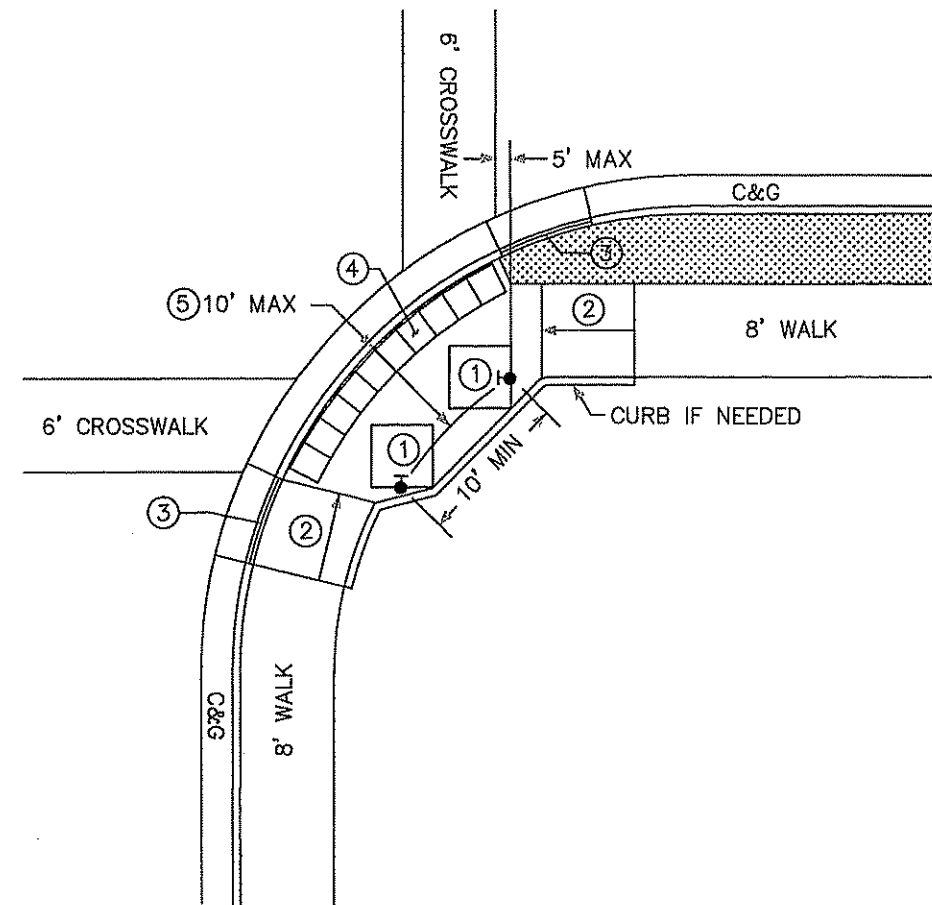
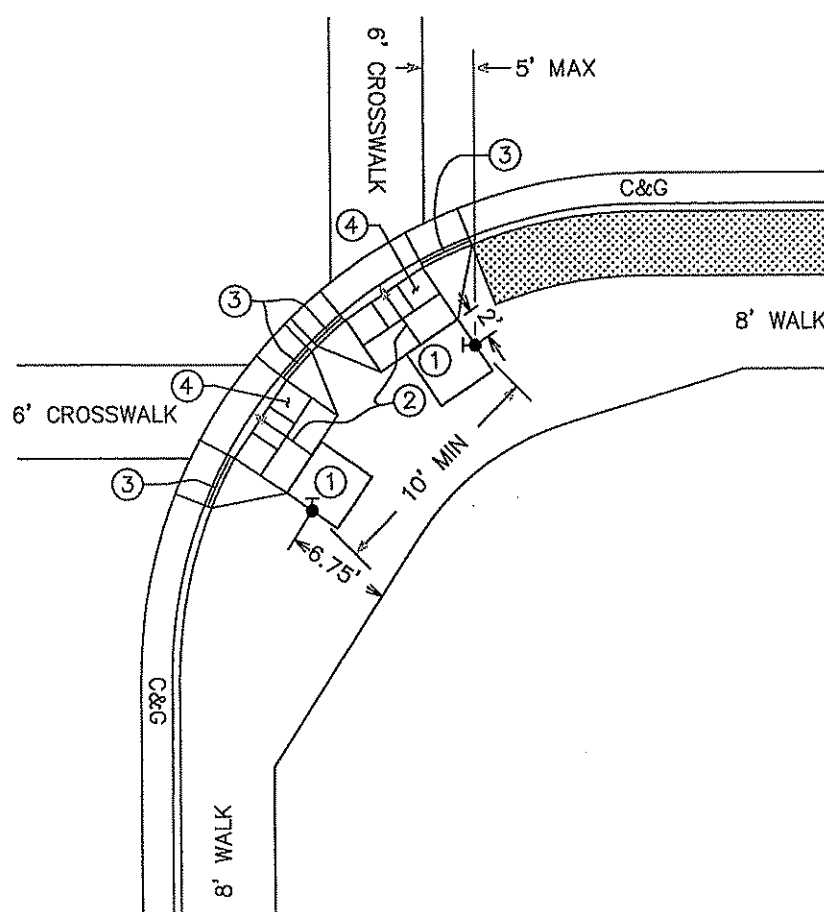

- ① 4'X4' MINIMUM LANDING AREA ADJACENT TO PUSH BUTTON. (2% SLOPE MAX.)
- ② RAMP - SLOPE (5% PREFERRED 8% MAX).
- ③ CURB TAPER SECTION AT 1:10 (10%) (HEIGHT OF CURB IS TAPERED TO 0").
- ④ DETECTABLE WARNING SURFACE (TRUNCATED DOMES) - RADIUS SECTIONS WHERE SPECIFIED.
- ⑤ DISTANCE FROM THE BACK OF CURB TO PUSH BUTTON STATION.

TYPICAL APS PEDESTRIAN PUSH BUTTON LOCATION

S.P. 0208-145  
S.A.P. 002-716-013

DRAWN BY:	JMG
DESIGNER:	JMG
CHECKED BY:	JMG

NO.	BY	DATE	REVISIONS

I HEREBY CERTIFY THAT THIS PLAN WAS PREPARED BY ME OR UNDER MY DIRECT SUPERVISION AND THAT I AM A DULY LICENSED PROFESSIONAL ENGINEER UNDER THE LAWS OF THE STATE OF MINNESOTA.

*John M. Gray*  
Name: John M. Gray, PE  
Lic. No. 22457  
Date: May 23, 2012

SEH  
PHONE: (651) 490-2000  
3535 VADNAIS CENTER DR.  
ST. PAUL, MN 55110

ANOKA COUNTY,  
MINNESOTA  
CITY OF HAM LAKE

REVISE SIGNAL SYSTEM  
APS PUSH BUTTON DETAILS  
TRUNK HIGHWAY 65 AT CSAH 116

FILE NO.	ANOKA 119012
SIGNAL SHEET	82
SG2 OF SG10	108

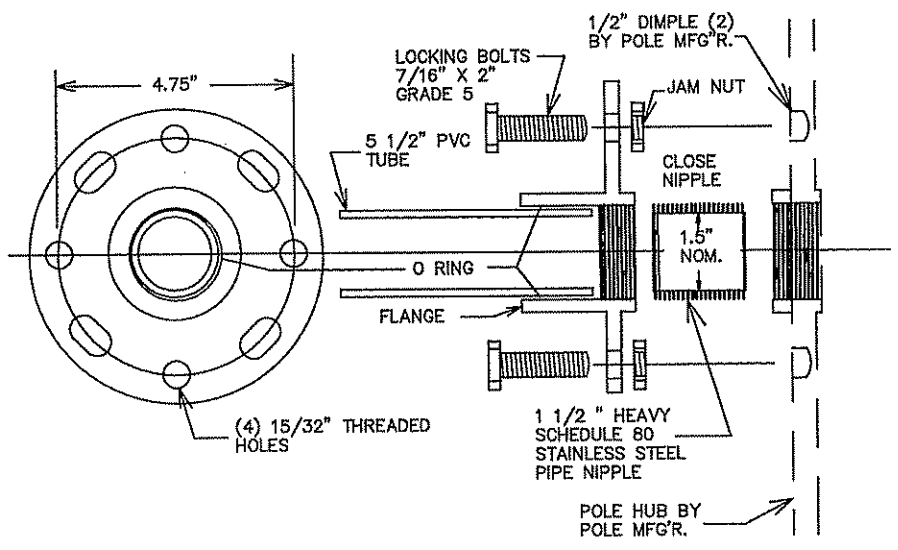

THREADED HUB AND FLANGE POLE ADAPTOR

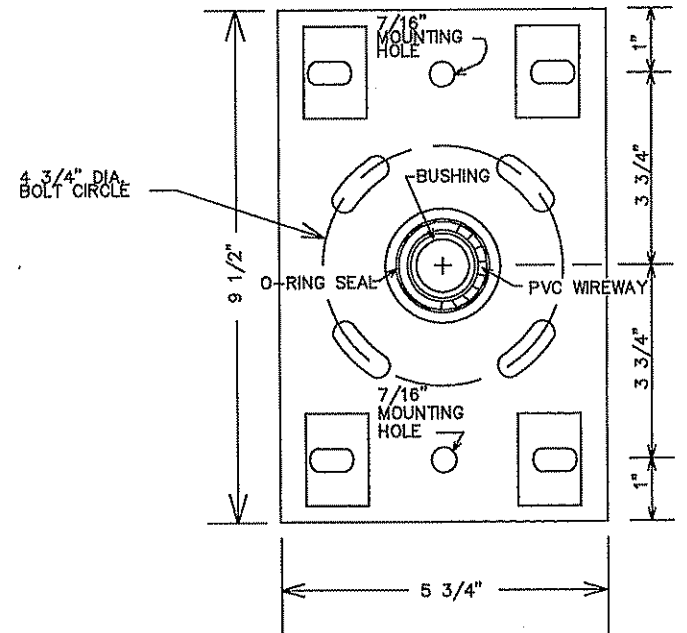

BOLT ON HUB & FLANGE

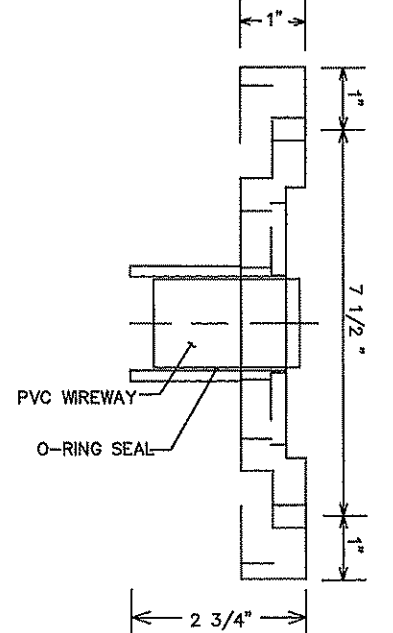

SIDE VIEW

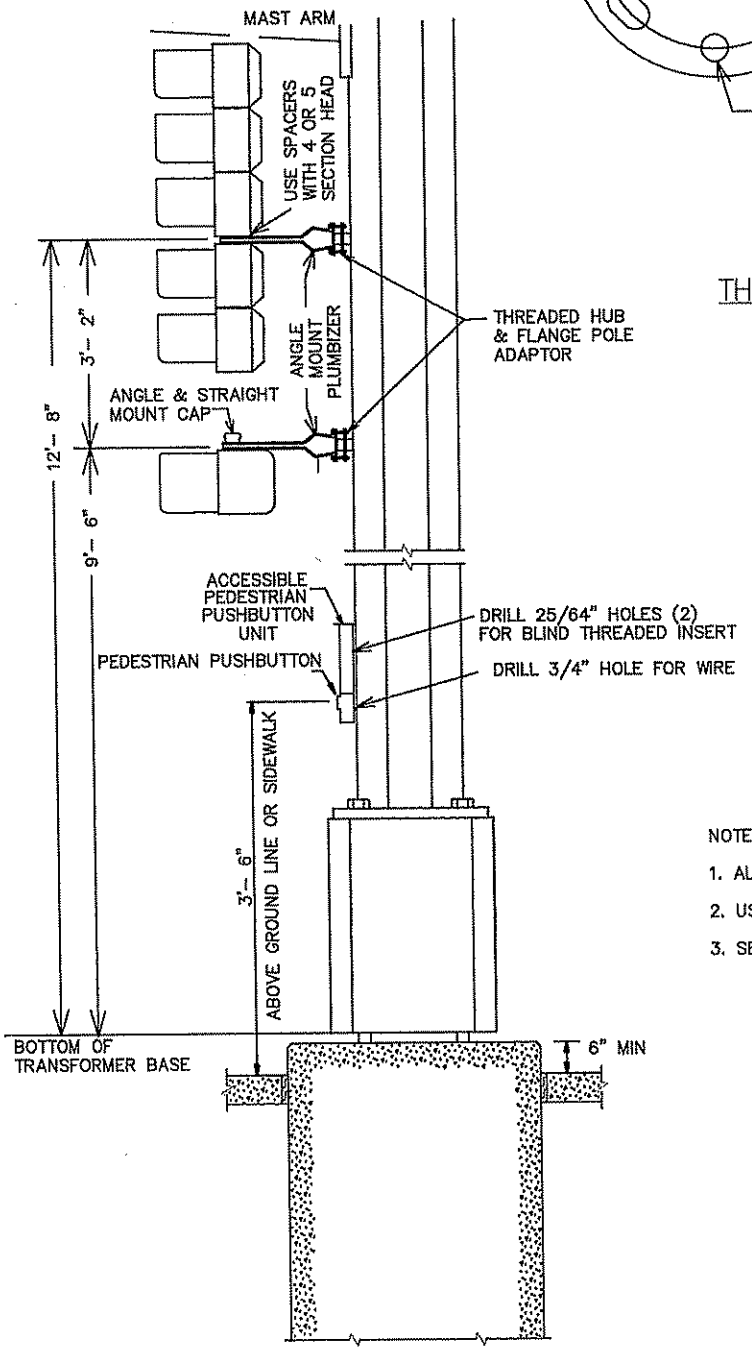

TYPICAL SIGNAL POLE MOUNTING  
NOT TO SCALE

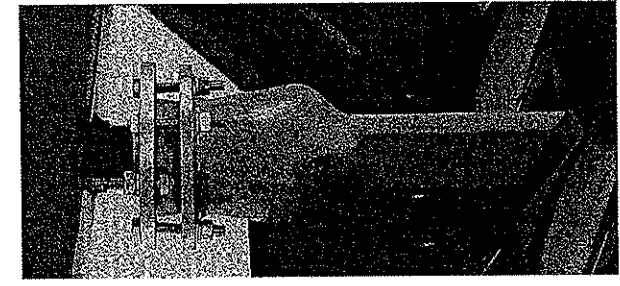

- NOTE:
1. ALL THREADED SURFACES TO BE COATED WITH ANTI-SEIZE COMPOUND.
  2. USE SIGNAL HEAD MOUNTED SPACERS FOR 4 & 5 SECTION POLY HEADS.
  3. SEE STANDARD PLATE NUMBER 8123 FOR ADDITIONAL SIGNAL POLE DETAILS.

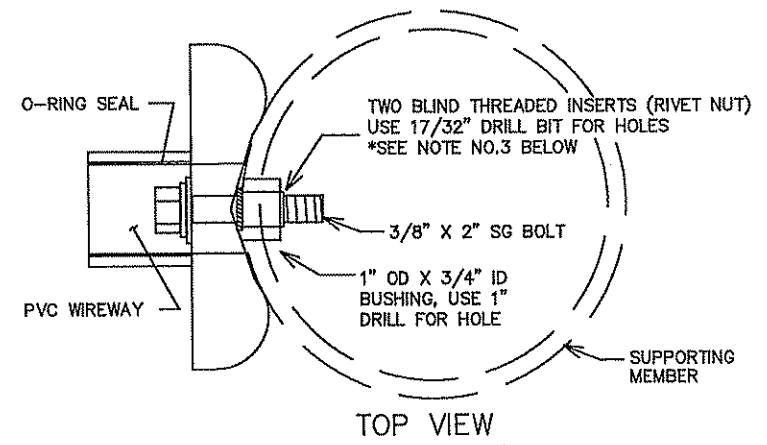

TOP VIEW

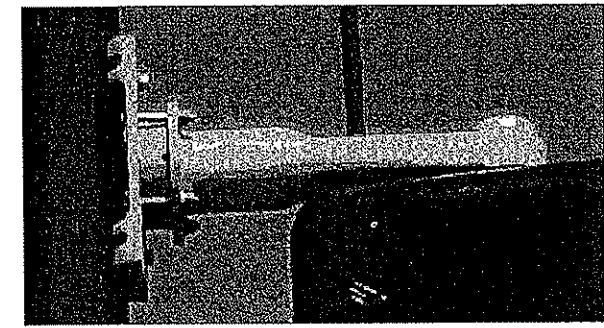

- NOTE:
1. ALL THREADED SURFACES TO BE COATED WITH ANTI-SEIZE COMPOUND.
  2. USE SIGNAL HEAD MOUNTED SPACERS FOR 4 & 5 SECTION POLY HEADS.
  3. BLIND THREADED INSERTS (RIVET NUT) MUST BE INSTALLED USING MANUFACTURERS SPECIFIC INSTALLATION TOOL. NO OTHER METHOD OF INSTALLATION IS ACCEPTABLE.
  4. SEE STANDARD PLATE NUMBER 8122 FOR ADDITIONAL PEDESTAL POLE DETAILS.

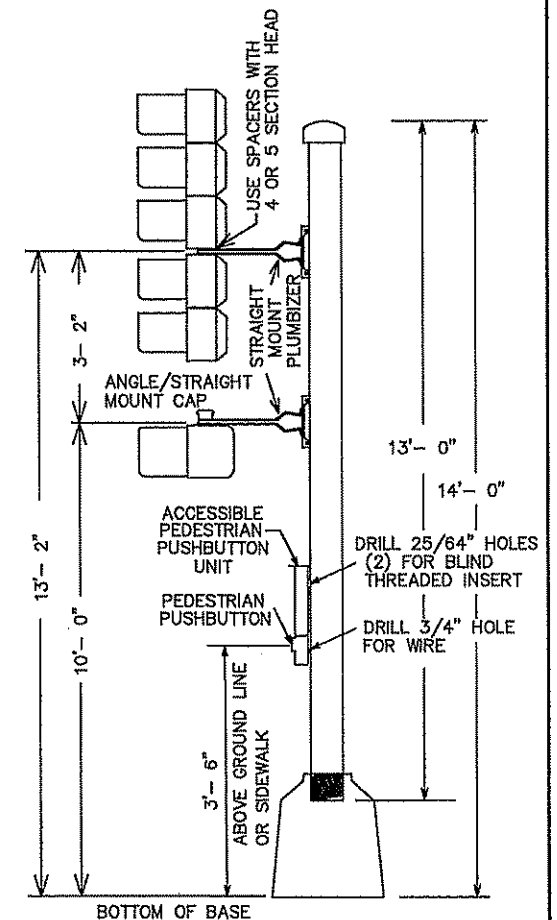

TYPICAL PEDESTAL MOUNTING  
NOT TO SCALE

S:\EVA\ANOKC\CAD\CAD\DRAWINGS\65-116\116-02\_SIGBASE.DWG

DRAWN BY: JMG  
DESIGNER: JMG  
CHECKED BY: JMG

DESIGN TEAM	NO.	BY	DATE	REVISIONS

I HEREBY CERTIFY THAT THIS PLAN WAS PREPARED BY ME OR UNDER MY DIRECT SUPERVISION AND THAT I AM A DULY LICENSED PROFESSIONAL ENGINEER UNDER THE LAWS OF THE STATE OF MINNESOTA.

*John M. Gray*  
Name: John M. Gray, PE  
Date: May 23, 2012  
Lic. No. 22457

SEH  
PHONE: (851) 490-2000  
3535 VADNAIS CENTER DR.  
ST. PAUL, MN 55110

ANOKA COUNTY,  
MINNESOTA  
CITY OF HAM LAKE

REVISE SIGNAL SYSTEM  
ONE WAY POLE MOUNT DETAILS  
TRUNK HIGHWAY 65 AT CSAH 116

FILE NO.  
ANOKC 119012  
SIGNAL SHEET  
SG3 OF SG10

83  
108

S.P. 0208-145  
S.A.P. 002-716-013

PVC LOOP DETECTORS			
NUMBER	SIZE (FT.)	LOCATION	STATUS
D1-1	2-6x6	15' & 45'	F & I
D1-2	2-6x6	0' & 30'	F & I
D2-1	6x6	550'	F & I
D2-2	6x6	550'	F & I
D3-1	6x6	40'	INPLACE
D3-2	6x6	10'	INPLACE
D4-1	6x6	250'	INPLACE
D4-2	6x15&6x6	AS SHOWN	INPLACE
D4-3	2-6x6	5' & 20'	INPLACE
D5-1	2-6x6	15' & 45'	F & I
D5-2	2-6x6	15' & 45'	F & I
D5-3	2-6x6	0' & 30'	F & I
D5-4	2-6x6	0' & 30'	F & I
D6-1	6x6	550'	F & I
D6-2	6x6	550'	F & I
D7-1	6x6	40'	INPLACE
D7-2	6x6	10'	INPLACE
D8-1	6x6	250'	INPLACE
D8-2	6x15&6x6	AS SHOWN	INPLACE
D8-3	2-6x6	10' & 25'	INPLACE

**REVISE SIGNAL SYSTEM:**  
 THE EXISTING SIGNAL SYSTEM IS BEING MODIFIED AT THE NW CORNER AND AT THE SOUTH MEDIAN TO ACCOMMODATE A NEW DUAL LEFT TURN LANE FOR NB TH 65. WORK WILL INCLUDE INSTALLATION OF A NEW NORTH MEDIAN MAST ARM AND POLE, INSTALLATION OF APS PUSH BUTTONS, REPLACEMENT OF PEDESTRIAN SIGNAL LENSES, REVISING SIGNAL PHASING FOR CSAH 116 APPROACHES FROM PROTECTED LEFT TURNS TO FLASHING YELLOW ARROW OPERATION, AND MISCELLANEOUS LOOP DETECTOR INSTALLATIONS.

**F & I** | APS PUSH BUTTON STATION  
 1-APS PUSH BUTTON & SIGN (RT ARROW) (PB6-2)  
 EXTEND INTO H.H.9:  
 2" CONDUIT  
 1-2/c#14

NOTE: LOCATION-DISTANCE FROM CROSSWALK OR STOP BAR TO FRONT OF DETECTOR.

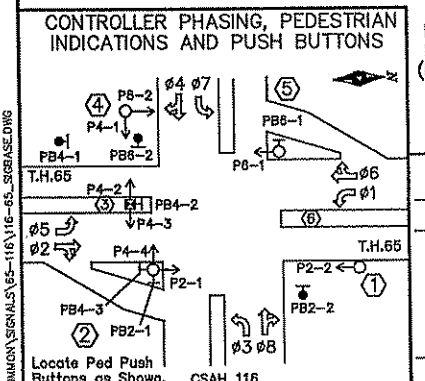
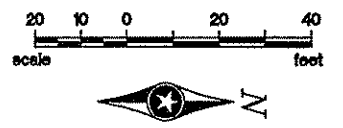
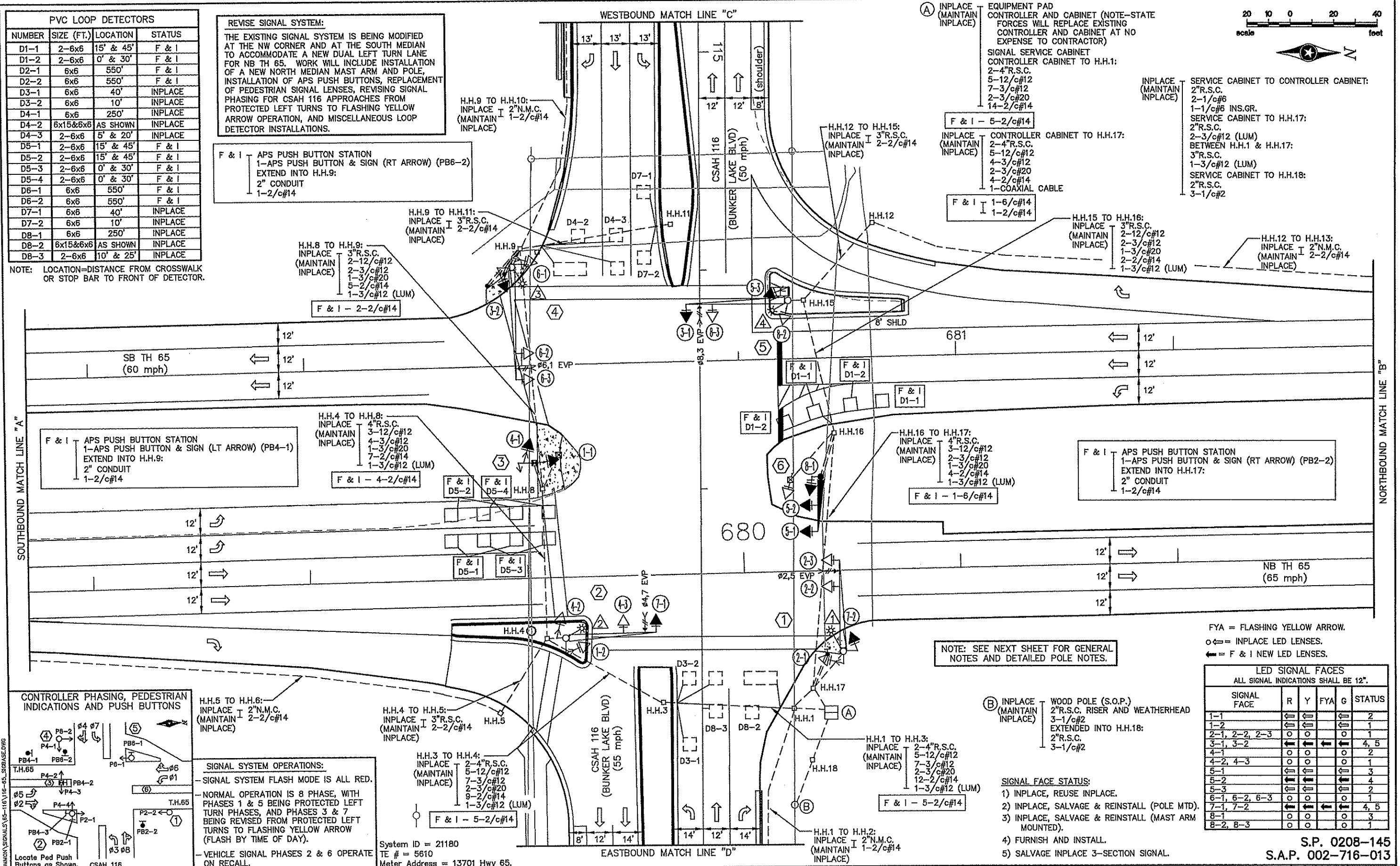

**H.H.5 TO H.H.6:**  
 INPLACE 2" N.M.C. (MAINTAIN 2-2/c#14)  
 INPLACE

**H.H.4 TO H.H.5:**  
 INPLACE 3" R.S.C. (MAINTAIN 2-2/c#14)  
 INPLACE

**H.H.3 TO H.H.4:**  
 INPLACE 2-4" R.S.C. (MAINTAIN 5-12/c#12)  
 INPLACE 7-3/c#12  
 INPLACE 2-3/c#20  
 INPLACE 9-2/c#14  
 INPLACE 1-3/c#12 (LUM)

**F & I** | 5-2/c#14

**SIGNAL SYSTEM OPERATIONS:**  
 - SIGNAL SYSTEM FLASH MODE IS ALL RED.  
 - NORMAL OPERATION IS 8 PHASE, WITH PHASES 1 & 5 BEING PROTECTED LEFT TURN PHASES, AND PHASES 3 & 7 BEING REVISED FROM PROTECTED LEFT TURNS TO FLASHING YELLOW ARROW (FLASH BY TIME OF DAY).  
 - VEHICLE SIGNAL PHASES 2 & 6 OPERATE ON RECALL.

System ID = 21180  
 TE # = 5610  
 Meter Address = 13701 Hwy 65.

NOTE: SEE NEXT SHEET FOR GENERAL NOTES AND DETAILED POLE NOTES.

FYA = FLASHING YELLOW ARROW.  
 ◊ = INPLACE LED LENSES.  
 ◊ = F & I NEW LED LENSES.

LED SIGNAL FACES					
ALL SIGNAL INDICATIONS SHALL BE 12".					
SIGNAL FACE	R	Y	FYA	G	STATUS
1-1	◊	◊	◊	◊	2
1-2	◊	◊	◊	◊	1
2-1, 2-2, 2-3	◊	◊	◊	◊	1
3-1, 3-2	◊	◊	◊	◊	4, 5
4-1	◊	◊	◊	◊	2
4-2, 4-3	◊	◊	◊	◊	1
5-1	◊	◊	◊	◊	3
5-2	◊	◊	◊	◊	4
5-3	◊	◊	◊	◊	2
6-1, 6-2, 6-3	◊	◊	◊	◊	1
7-1, 7-2	◊	◊	◊	◊	4, 5
8-1	◊	◊	◊	◊	3
8-2, 8-3	◊	◊	◊	◊	1

- SIGNAL FACE STATUS:**
- 1) INPLACE, REUSE INPLACE.
  - 2) INPLACE, SALVAGE & REINSTALL (POLE MTD).
  - 3) INPLACE, SALVAGE & REINSTALL (MAST ARM MOUNTED).
  - 4) FURNISH AND INSTALL.
  - 5) SALVAGE INPLACE 3-SECTION SIGNAL.

DRAWN BY: JMG	DESIGNER: JMG	CHECKED BY: JMG
NO.	BY	DATE

I HEREBY CERTIFY THAT THIS PLAN WAS PREPARED BY ME OR UNDER MY DIRECT SUPERVISION AND THAT I AM A DULY LICENSED PROFESSIONAL ENGINEER UNDER THE LAWS OF THE STATE OF MINNESOTA.

*John M. Gray*  
 Name: John M. Gray, PE  
 Lic. No. 22457

Date: May 23, 2012

SEH  
 PHONE: (651) 490-2000  
 3535 VADNAIS CENTER DR.  
 ST. PAUL, MN 55110

ANOKA COUNTY,  
 MINNESOTA  
 CITY OF HAM LAKE

REVISE SIGNAL SYSTEM  
 INTERSECTION LAYOUT  
 TRUNK HIGHWAY 65 AT CSAH 116

FILE NO.  
 ANOKC 119012  
 SIGNAL SHEET  
 SG4 OF SG10

S.P. 0208-145  
 S.A.P. 002-716-013

84  
 108

**NOTES:**

- 1) LOCATION OF FOUNDATIONS, PUSH BUTTON STATION, AND LOOP DETECTORS SHALL BE DETERMINED IN THE FIELD BY ENGINEER AND MNDOT METRO TRAFFIC OFFICE PERSONNEL.
- 2) EACH SIGNAL FACE SHALL HAVE A BACKGROUND SHIELD.
- 3) NEW LOOP DETECTORS SHALL BE FURNISHED AND INSTALLED IN ACCORDANCE WITH THE SPECIAL PROVISIONS AND MNDOT STANDARD PLATE NO. 8132B.
- 4) ALL HANDHOLES ARE INPLACE (PVC HANDHOLES WITH METAL FRAMES AND COVERS) AND SHALL BE REUSED AND MAINTAINED INPLACE. HANDHOLES 5, 6, 7, 8, 12, 13, 14, 15, AND 16 SHALL BE ADJUSTED BY CONTRACTOR TO FINISHED SURROUNDING GRADE. SEE SPECIAL PROVISIONS (INCIDENTAL).
- 5) SEE SPECIAL PROVISIONS REGARDING REMOVAL, SALVAGING AND INSTALLATION OF INPLACE SIGNAL EQUIPMENT.
- 6) INPLACE ITEMS TO BE REUSED INPLACE AS PART OF THE REVISE SIGNAL SYSTEM SHALL BE PROTECTED AND MAINTAINED INPLACE. SEE SPECIAL PROVISIONS.
- 7) CONTRACTOR SHALL MAINTAIN OPERATION OF THE INPLACE SIGNAL SYSTEM, EXCEPT AS APPROVED BY ENGINEER.
- 8) F & I = MATERIALS TO BE FURNISHED AND INSTALLED BY THE CONTRACTOR AS PART OF REVISE SIGNAL SYSTEM.
- 9) S & I = MATERIALS TO BE SALVAGED AND INSTALLED BY THE CONTRACTOR AS PART OF REVISE SIGNAL SYSTEM.
- 10) ALL PEDESTRIAN INDICATIONS (MCCAIN HOUSINGS AND VISORS) ARE INPLACE ONE-SECTION INDICATIONS AND SHALL BE REUSED, RELOCATED, AND MADE OPERATIONAL AS SHOWN, EXCEPT AS FOLLOWS: CONTRACTOR SHALL SALVAGE ALL INPLACE LED "HAND/WALKING PERSON" LENSES AND SHALL FURNISH, INSTALL, AND MAKE OPERATIONAL NEW LED COUNTDOWN TIMER "HAND/WALKING PERSON" LENSES IN THEIR PLACE (INCIDENTAL TO "REVISE SIGNAL SYSTEM" PAY ITEM). SEE SPECIAL PROVISIONS.
- 11) ALL INPLACE VEHICLE SIGNAL INDICATIONS ARE LED. NEW VEHICLE SIGNAL INDICATIONS TO BE FURNISHED AND INSTALLED BY THE CONTRACTOR SHALL ALSO BE LED. SEE SPECIAL PROVISIONS.
- 12) SEE DETAILS AND SPECIAL PROVISIONS REGARDING TYPE C AND TYPE D SIGNS TO BE FURNISHED AND INSTALLED BY CONTRACTOR (INCIDENTAL TO "REVISE SIGNAL SYSTEM" PAY ITEM).
- 13) CONTRACTOR SHALL COORDINATE ALL WORK IN CONTROLLER CABINET WITH CONTROLLER AND CABINET REPLACEMENT WORK TO BE COMPLETED BY THE STATE (AT NO EXPENSE TO THE CONTRACTOR).

① INPLACE (MAINTAIN INPLACE) PA100 POLE FOUNDATION  
 TYPE PA100-A-40-D30-9 (DAVIT AT 350 DEG.)  
 PA100 SWING-AWAY HINGES  
 LUMINAIRE-250 W HPS  
 2-ONE WAY SIGNALS-OVERHEAD (0', 12')  
 TYPE 10B-POLE MOUNTED AT 180 DEG.  
 R9-3a SIGN PANEL-FACING POLE 6  
 2-R6-1 SIGN PANELS AT 0 DEG. & 180 DEG.  
 ONE WAY EVP DETECTOR AND LIGHT (#2,5)  
 TYPE D SIGN PANEL-OVERHEAD (CSAH 116)  
 RADIO INTERCONNECT ANTENNA-  
 LUMINAIRE EXTENSION MOUNTED  
 EXTENDED INTO H.H.17:  
 3"R.S.C.  
 2-12/c#12  
 2-3/c#12  
 1-3/c#20  
 1-COAX CABLE (ANTENNA)  
 2-3/c#12 (LUM)

INPLACE (SALVAGE) ONE WAY SIGNAL-POLE MOUNTED AT 90 DEG. (OLD 7-2)  
 1-PEDESTRIAN SIGNAL LENS (MAINTAIN HOUSING AND VISOR INPLACE)  
 INPLACE (REMOVE) TYPE 10A BRACKETING-POLE MOUNTED AT 90 DEG.  
 1-PEDESTRIAN PUSH BUTTON & SIGN (R10-4b)  
 "MEANING OF WALK" STICKER AT 0 DEG.  
 TYPE D SIGN PANEL-OVERHEAD ("BUNKER LAKE BLVD")  
 F & I TYPE 10A BRACKETING-POLE MOUNTED AT 90 DEG.  
 ONE WAY SIGNAL-POLE MOUNTED AT 90 DEG.  
 (4-SECTION SIGNAL) (7-2)  
 1-C.D. LED PEDESTRIAN SIGNAL LENS AT 180 DEG.  
 PLUG/CAP HOLE ON 0 DEG. SIDE OF POLE (WHERE PUSH BUTTON USED TO BE)  
 TYPE D SIGN PANEL-OVERHEAD (D-1)

② INPLACE (MAINTAIN INPLACE) PA100 POLE FOUNDATION  
 TYPE PA100-A-40-D40-9 (DAVIT AT 350 DEG.)  
 LUMINAIRE-250 W HPS  
 1-ONE WAY SIGNAL-OVERHEAD AT 15' (4-3)  
 2-TYPE 10B-POLE MOUNTED AT 90 DEG. & 180 DEG.  
 R6-1L SIGN PANEL AT 0 DEG.  
 ONE WAY EVP DETECTOR AND LIGHT (#4,7)  
 EXTENDED INTO H.H.4:  
 3"R.S.C.  
 2-12/c#12  
 3-3/c#12  
 1-3/c#20  
 2-3/c#12 (LUM)

INPLACE (SALVAGE) 1-ONE WAY SIGNAL-OVERHEAD AT 0' (OLD 7-1)  
 2-PEDESTRIAN SIGNAL LENSES (MAINTAIN HOUSINGS AND VISORS INPLACE)  
 INPLACE (REMOVE) 2-PEDESTRIAN PUSH BUTTONS & SIGNS (R10-4b)  
 "MEANING OF WALK" STICKER AT 315 DEG.  
 F & I 1-ONE WAY SIGNAL-OVERHEAD AT 0' (4-SECTION SIGNAL) (7-1)  
 2-C.D. LED PEDESTRIAN SIGNAL LENSES AT 90 DEG./180 DEG.  
 PLUG/CAP HOLES ON 0 DEG. & 270 DEG. SIDES OF POLE  
 (WHERE PUSH BUTTONS USED TO BE)  
 1-APS PUSH BUTTON & SIGN (RT ARROW) (PB2-1)  
 1-APS PUSH BUTTON & SIGN (LT ARROW) (PB4-3)  
 R10-X12 SIGN PANEL-ADJACENT TO 7-1  
 TYPE D SIGN PANEL-OVERHEAD (D-2)  
 1-2/c#14

③ INPLACE (S & I) 10' PEDESTAL POLE, BASE, AND WIND COLLAR  
 TYPE 6D  
 1-12/c#12  
 2-3/c#12  
 INPLACE (SALVAGE) 2-PEDESTRIAN SIGNAL LENSES (MAINTAIN AND REUSE HOUSINGS AND VISORS AS SHOWN)  
 INPLACE (REMOVE) PEDESTAL FOUNDATION  
 1-PEDESTRIAN PUSH BUTTON & SIGN (R10-4b)  
 "MEANING OF WALK" STICKER (NORTH SIDE OF POLE)  
 EXTENDED INTO H.H.8:  
 3"R.S.C.  
 F & I PEDESTAL FOUNDATION  
 2-C.D. LED PEDESTRIAN SIGNAL LENSES  
 PLUG/CAP HOLE ON NORTH SIDE OF POLE (WHERE PUSH BUTTON USED TO BE)  
 1-APS PUSH BUTTON & SIGN (DBL ARROW) (PB4-2)  
 EXTEND INTO H.H.8:  
 3"R.S.C.

④ INPLACE (MAINTAIN INPLACE) PA100 POLE FOUNDATION  
 TYPE PA100-A-50-D40-9 (DAVIT AT 350 DEG.)  
 PA100 SWING-AWAY HINGES  
 LUMINAIRE-250 W HPS  
 2-ONE WAY SIGNALS-OVERHEAD (0', 12')  
 TYPE 10B-POLE MOUNTED AT 180 DEG. (6-1, P6-2)  
 2-R6-1 SIGN PANELS AT 0 DEG. & 180 DEG.  
 ONE WAY EVP DETECTOR AND LIGHT (#6,1)  
 TYPE D SIGN PANEL-OVERHEAD (CSAH 116)  
 EXTENDED INTO H.H.9:  
 3"R.S.C.  
 2-12/c#12  
 2-3/c#12  
 1-3/c#20  
 1-3/c#12 (LUM)

INPLACE (S & I) 1-SET PEDESTRIAN INDICATIONS (HOUSING AND VISOR)-  
 POLE MOUNTED AT 90 DEG. (FOR P4-1)  
 INPLACE (SALVAGE) ONE WAY SIGNAL-POLE MOUNTED AT 90 DEG. (OLD 3-2)  
 2-PEDESTRIAN SIGNAL LENSES (REUSE/MAINTAIN HOUSINGS AND VISORS AS SHOWN)  
 INPLACE (REMOVE) TYPE 10B BRACKETING-POLE MOUNTED AT 90 DEG.  
 2-PEDESTRIAN PUSH BUTTONS & SIGNS (R10-4b)  
 "MEANING OF WALK" STICKER AT 315 DEG.  
 TYPE D SIGN PANEL-OVERHEAD ("BUNKER LAKE BLVD")  
 F & I TYPE 10B BRACKETING-POLE MOUNTED AT 90 DEG.  
 ONE WAY SIGNAL-POLE MOUNTED AT 90 DEG.  
 (4-SECTION SIGNAL) (3-2)  
 2-C.D. LED PEDESTRIAN SIGNAL LENSES AT 90 DEG./180 DEG.  
 PLUG/CAP HOLE ON 0 DEG. & 270 DEG. SIDES OF POLE  
 (WHERE PUSH BUTTONS USED TO BE)  
 TYPE D SIGN PANEL-OVERHEAD (D-3)

⑤ INPLACE (MAINTAIN INPLACE) PA100 POLE FOUNDATION  
 TYPE PA100-A-45-D30-9 (DAVIT AT 350 DEG.)  
 LUMINAIRE-250 W HPS  
 1-ONE WAY SIGNAL-OVERHEAD AT 12' (8-3)  
 TYPE 10A-POLE MOUNTED AT 270 DEG. (8-2)  
 R9-3a SIGN PANEL-FACING POLE 6  
 R6-1L SIGN PANEL AT 0 DEG.  
 ONE WAY EVP DETECTOR AND LIGHT (#8,3)  
 EXTENDED INTO H.H.15:  
 3"R.S.C.  
 2-12/c#12  
 2-3/c#12  
 1-3/c#20  
 1-3/c#12 (LUM)

INPLACE (S & I) ONE WAY VEHICLE SIGNAL FACE (RELABEL FROM 5-2 TO 5-3)-RELOCATE FROM 0 DEG. TO 90 DEG. SIDE OF POLE  
 1-SET PEDESTRIAN SIGNAL HOUSING AND VISOR-RELOCATE FROM 0 DEG. TO 90 DEG. SIDE OF POLE (P6-1)  
 INPLACE (SALVAGE) 1-ONE WAY SIGNAL-OVERHEAD AT 0' (OLD 3-1)  
 1-PEDESTRIAN SIGNAL LENS (MAINTAIN AND REUSE HOUSING AND VISOR AS SHOWN)  
 INPLACE (REMOVE) TYPE 10B BRACKETING-POLE MOUNTED 0 DEG.  
 1-PEDESTRIAN PUSH BUTTON & SIGN (R10-4b)  
 "MEANING OF WALK" STICKER AT 90 DEG.  
 F & I 1-ONE WAY SIGNAL-OVERHEAD AT 0' (4-SECTION SIGNAL) (3-1)  
 TYPE 10B BRACKETING-POLE MOUNTED 90 DEG.  
 CAP OPEN HUB ON 0 DEG. SIDE OF POLE  
 1-C.D. LED PEDESTRIAN SIGNAL LENS AT 90 DEG.  
 PLUG/CAP HOLES ON 90 DEG. SIDE OF POLE (WHERE PUSH BUTTON USED TO BE)  
 1-APS PUSH BUTTON & SIGN (RT ARROW) (PB6-1)  
 R10-X12 SIGN PANEL-ADJACENT TO 3-1  
 TYPE D SIGN PANEL-OVERHEAD (D-4)

⑥ INPLACE (S & I) ONE WAY VEHICLE SIGNAL FACE (5-1)-RELOCATE FROM PEDESTAL POLE TO OVERHEAD (END OF MAST ARM)  
 ONE WAY VEHICLE SIGNAL FACE (8-1)-RELOCATE FROM PEDESTAL POLE TO MAST ARM POLE AT 90 DEG.  
 2-R9-3a SIGN PANELS-FACING POLES 1 & 5  
 1-12/c#12  
 INPLACE (REMOVE) PEDESTAL FOUNDATION  
 10' PEDESTAL POLE, BASE AND WIND COLLAR  
 TYPE 6A BRACKETING  
 EXTENDED INTO H.H.16:  
 3"R.S.C.  
 F & I PA85 POLE FOUNDATION  
 TYPE PA85-A-25  
 1-ANGLE MOUNT-OVERHEAD AT 0' (FOR INPLACE RELOCATED SIGNAL FACE 5-1)  
 1-STRAIGHT MOUNT SIGNAL-OVERHEAD AT 11' (5-2)  
 1-ANGLE MOUNT-POLE MOUNTED 90 DEG. (FOR INPLACE RELOCATED SIGNAL FACE 8-1)  
 EXTEND INTO H.H.16:  
 3"R.S.C.  
 1-6/c#14

System ID = 21180  
 TE # = 5610  
 Meter Address = 13701 Hwy 65.

S.P. 0208-145  
 S.A.P. 002-716-013

DRAWN BY: JMG  
 DESIGNER: JMG  
 CHECKED BY: JMG  
 DESIGN TEAM

NO. BY DATE

REVISIONS

I HEREBY CERTIFY THAT THIS PLAN WAS PREPARED BY ME OR UNDER MY DIRECT SUPERVISION AND THAT I AM A DULY LICENSED PROFESSIONAL ENGINEER UNDER THE LAWS OF THE STATE OF MINNESOTA.  
 Date: May 23, 2012  
 Name: John M. Gray, PE  
 Lic. No. 22457

SEH  
 PHONE: (651) 490-2000  
 3535 VADNAIS CENTER DR.  
 ST. PAUL, MN 55110

ANOKA COUNTY,  
 MINNESOTA  
 CITY OF HAM LAKE

REVISE SIGNAL SYSTEM  
 INTERSECTION LAYOUT  
 TRUNK HIGHWAY 65 AT CSAH 116

FILE NO.  
 ANOKC 119012  
 SIGNAL SHEET  
 SG5 OF SG10

85  
 108

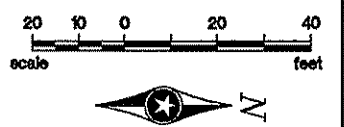
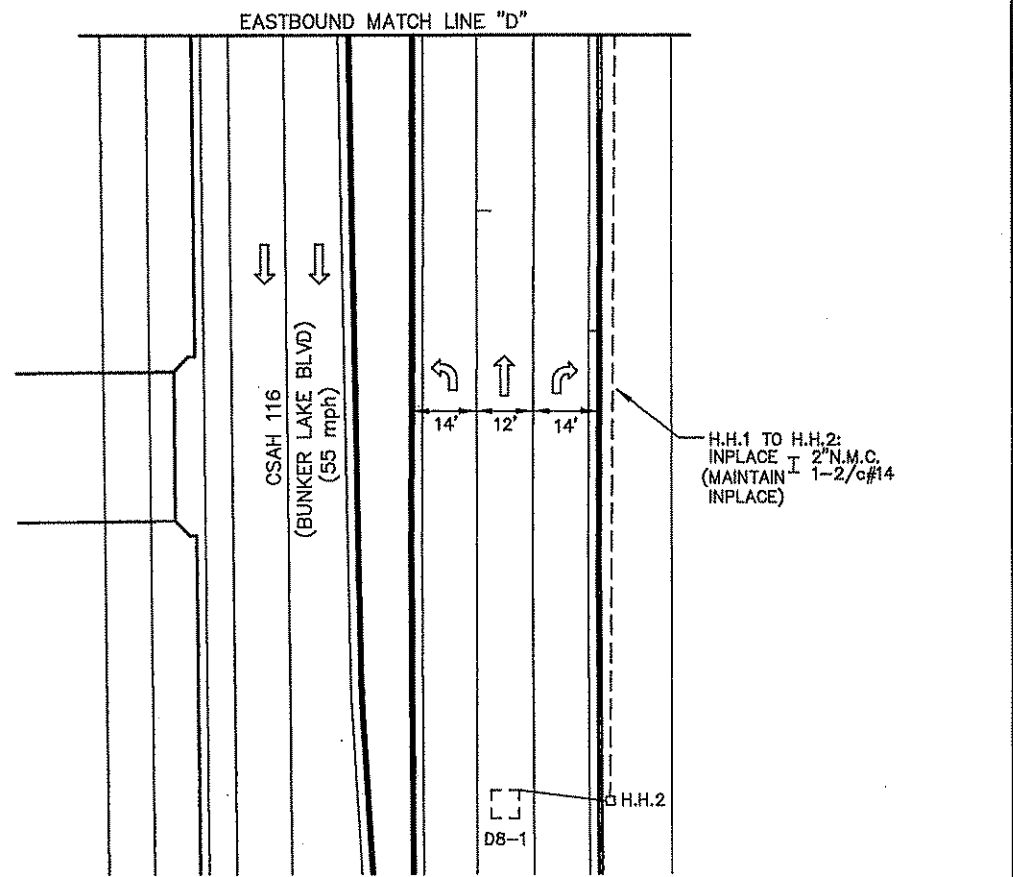
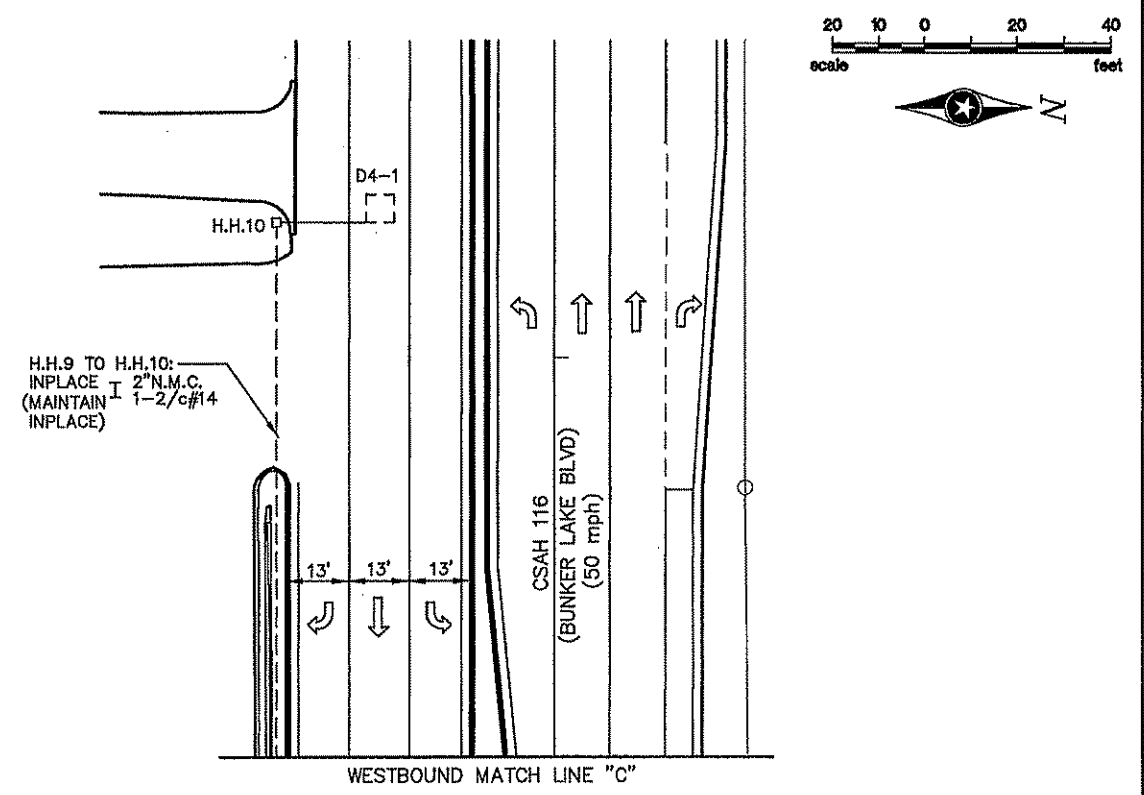
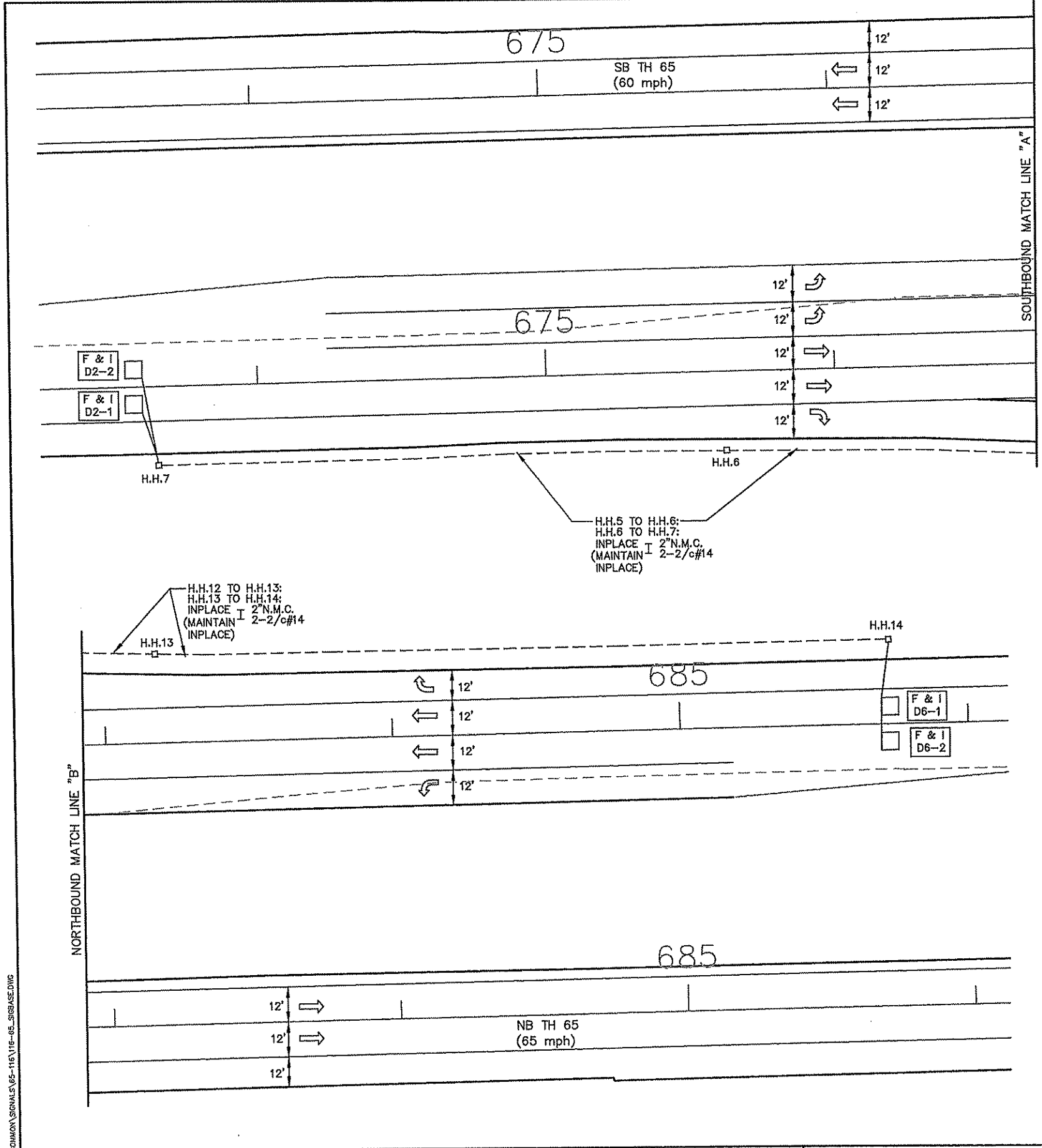

System ID = 21180  
TE # = 5610  
Meter Address = 13701 Hwy 65.

S.P. 0208-145  
S.A.P. 002-716-013

DESIGN TEAM	NO.	BY	DATE	REVISIONS

DRAWN BY: JMG  
DESIGNER: JMG  
CHECKED BY: JMG

I HEREBY CERTIFY THAT THIS PLAN WAS PREPARED BY ME OR UNDER MY DIRECT SUPERVISION AND THAT I AM A DULY LICENSED PROFESSIONAL ENGINEER UNDER THE LAWS OF THE STATE OF MINNESOTA.

*JMG*  
Name: John M. Gray, PE  
Lic. No. 22457  
Date: May 23, 2012

SEH  
PHONE: (651) 490-2000  
3535 VADNAIS CENTER DR.  
ST. PAUL, MN 55110

ANOKA COUNTY,  
MINNESOTA  
CITY OF HAM LAKE

REVISE SIGNAL SYSTEM  
INTERSECTION LAYOUT  
TRUNK HIGHWAY 65 AT CSAH 116

FILE NO.  
ANOKC 119012  
SIGNAL SHEET  
SG6 OF SG10

86  
108

S:\A\A\COMMON\SIGNALE\05-116\16-65\_SRRASE.DWG

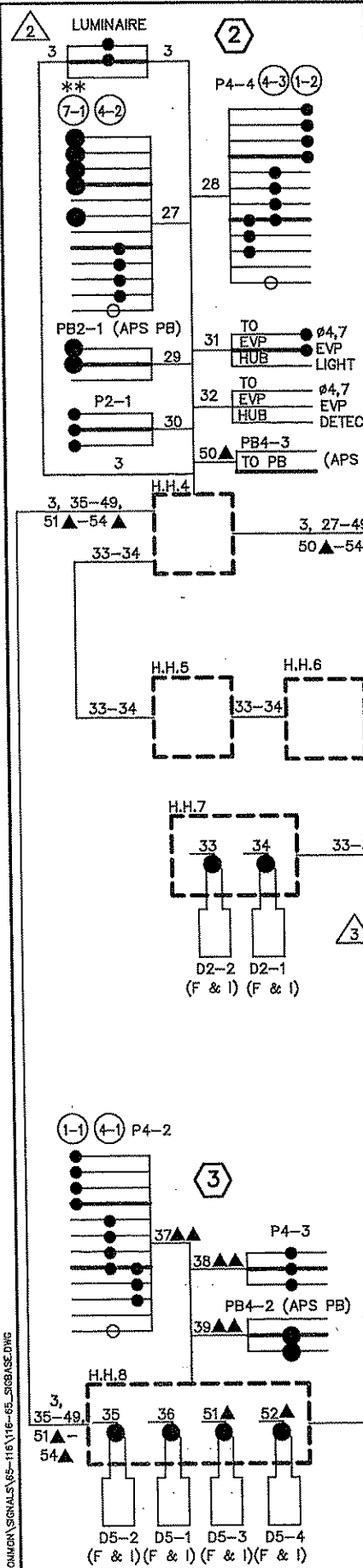

**NOTES:**

- 1) ALL CABLES AND CONDUCTORS ARE INPLACE AND SHALL BE REUSED AS SHOWN, EXCEPT WHERE DENOTED BY ▲ (▲ = CABLES AND CONDUCTORS TO BE FURNISHED AND INSTALLED BY CONTRACTOR), OR AS DENOTED BELOW.
- 2) ● = INPLACE TERMINATION ON INPLACE CABLE (MAINTAIN AND REUSE INPLACE).
- 3) ● = NEW TERMINATION ON INPLACE/NEW CABLE.
- 4) ▲▲ = INPLACE CABLES AND CONDUCTORS TO BE SALVAGED & INSTALLED BY CONTRACTOR AS SHOWN.
- 5) \*\* DENOTES NEW LABELING OR TERMINATION ON EXISTING CABLE.
- 6) (F&I) DENOTES NEW LOOP DETECTORS TO BE FURNISHED AND INSTALLED BY CONTRACTOR.

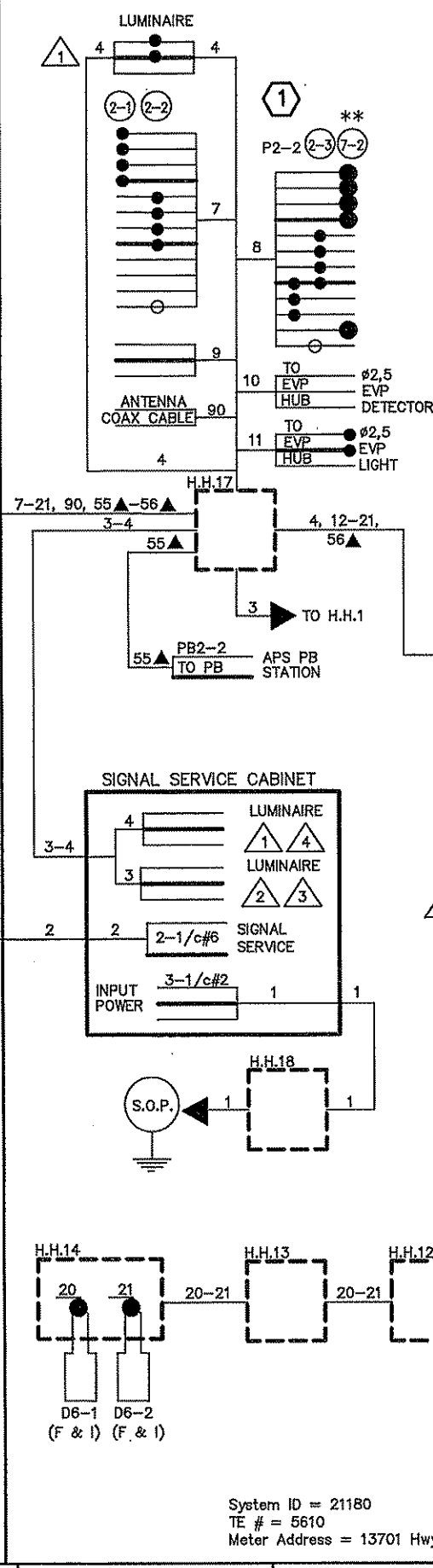
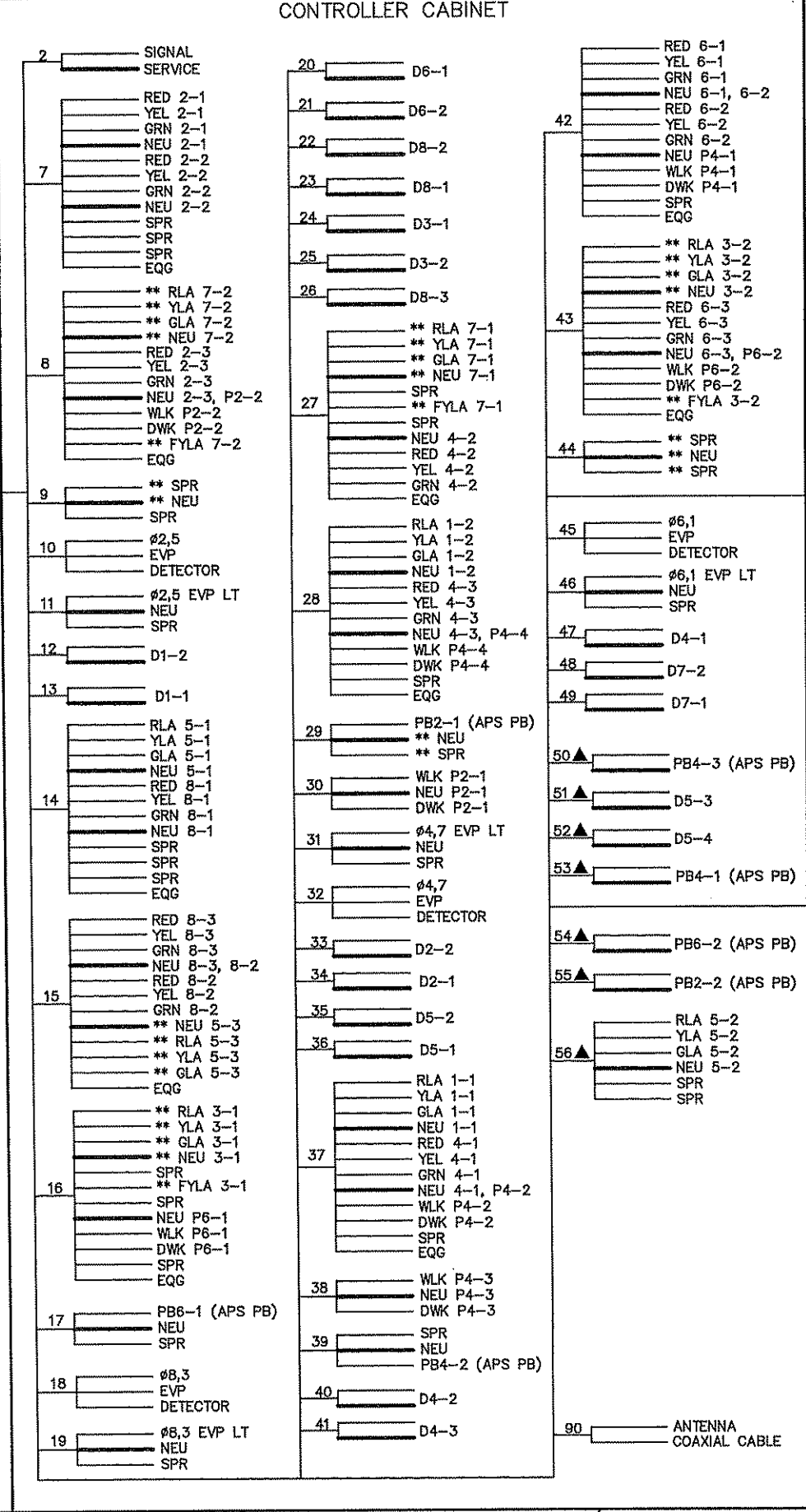

### CONDUCTOR COLOR CODING

R	BLK	2-1/c#6
O	WH	
BL		
WH		
R/BLK	R	
O/BLK	WH	3/c#12
BL/BLK	BLK	
WH/BLK		
BLK	BLK	2/c#14
BLK/WH	CLEAR	
G/BLK		
G		
	R OR O	
	WH OR YEL	3/c#20
	BLK OR BL	

**NOTES:**  
ALL TERMINAL BLOCK CONNECTIONS SHALL BE ARRANGED AS SPECIFIED ABOVE.

DRAWN BY: JMG  
 DESIGNER: JMG  
 CHECKED BY: JMG

DESIGN TEAM: \_\_\_\_\_  
 NO. BY DATE

REVISIONS: \_\_\_\_\_

I HEREBY CERTIFY THAT THIS PLAN WAS PREPARED BY ME OR UNDER MY DIRECT SUPERVISION AND THAT I AM A DULY LICENSED PROFESSIONAL ENGINEER UNDER THE LAWS OF THE STATE OF MINNESOTA.

*John M. Gray*  
 Name: John M. Gray, PE  
 Date: May 23, 2012  
 Lic. No. 22457

**SEH**  
 PHONE: (651) 490-2000  
 3635 VADONIS CENTER DR.  
 ST. PAUL, MN 55110

**ANOKA COUNTY, MINNESOTA**  
**CITY OF HAM LAKE**

**REVISE SIGNAL SYSTEM**  
**FIELD WIRING DIAGRAM**  
**TRUNK HIGHWAY 65 AT CSAH 116**

FILE NO. ANOKC 119012  
 SIGNAL SHEET 87  
 SGT OF S610 108

System ID = 21180  
 TE # = 5610  
 Meter Address = 13701 Hwy 65.

S.P. 0208-145  
 S.A.P. 002-716-013

**NOTES:**

- 1) SALVAGE TEMPORARY SIGNAL SYSTEM (INCIDENTAL TO CONSTRUCTION OF PERMANENT SIGNAL SYSTEM - SEE SPECIAL PROVISIONS).
- 2) SEE SPECIAL PROVISIONS FOR PEDESTRIAN INDICATIONS, LED INDICATIONS, AND STATE FURNISHED MATERIALS.
- 3) LOCATIONS OF POLES, PEDESTALS, PAD, HANDHOLES AND LOOP DETECTORS SHALL BE DETERMINED BY MN/DOT TRAFFIC OFFICE PERSONNEL.
- 4) FOR TYPE "D" SIGNS AND PAVEMENT MARKINGS SEE SHEET NO. 40.
- 5) A 21 mm HALF COUPLING, 21 mm PIPE NIPPLE AND CONDUIT OUTLET BODY FOR EMERGENCY VEHICLE PRE-EMPTION EQUIPMENT SHALL BE FURNISHED AND INSTALLED 1.8 m FROM THE END OF EACH MAST ARM.
- 6) FOR EQUIPMENT PAD LAYOUT SEE SHEET NO. 36.
- 7) FOR SERVICE CABINET DETAILS SEE SHEET NO. 37.
- 8) FOR NMC LOOP DETAILS SEE SHEET NO. 38.

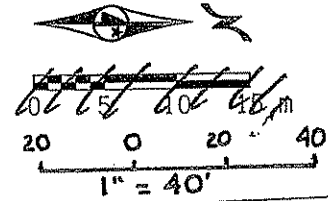

**4** PA100 POLE FOUNDATION  
 TYPE PA100-A-15.2-D12.2-2.7 (DAVIT AT 350°)  
 2-SWING AWAY HINGES  
 2-ONE WAY SIGNALS OVERHEAD AT 0 m AND 3.4 m  
 2-TYPE 10B POLE MOUNTED AT 90° AND 180°  
 ONE WAY EVP DETECTOR AND CONFIRMATORY LIGHT  
 LUMINAIRE-250 W HPS  
 2-PEDESTRIAN PUSH BUTTONS AND SIGNS (R10-4B)  
 2-SIGNS (R6-1L AND R6-1R)  
 EXTEND INTO HH 9  
 78 mm RSC  
 2-12/C #12  
 3-3/C #12  
 1-3/C #20

**2** PA100 POLE FOUNDATION  
 TYPE PA100-A-12.2-D12.2-2.7 (DAVIT AT 350°)  
 2-ONE WAY SIGNALS OVERHEAD AT 0 m AND 3.4 m  
 2-TYPE 10B POLE MOUNTED AT 90° AND 180°  
 ONE WAY EVP DETECTOR AND CONFIRMATORY LIGHT  
 LUMINAIRE-250 W HPS  
 2-PEDESTRIAN PUSH BUTTONS AND SIGNS (R10-4B)  
 2-SIGNS (R6-1L AND R6-1R)  
 EXTEND INTO HH 4  
 78 mm RSC  
 2-12/C #12  
 4-3/C #12  
 1-3/C #20

**3** PEDESTAL FOUNDATION  
 4.6 m PEDESTAL POLE AND BASE  
 TYPE 6D  
 PEDESTRIAN PUSH BUTTON AND SIGN (R10-4B)  
 EXTEND INTO HH 8  
 78 mm RSC  
 1-12/C #12  
 2-3/C #12

**5** PA100 POLE FOUNDATION  
 TYPE PA100-A-13.7-D12.2-2.7 (DAVIT AT 350°)  
 2-ONE WAY SIGNALS OVERHEAD AT 0 m AND 3.4 m  
 TYPE 10A POLE MOUNTED AT 270°  
 TYPE 10B POLE MOUNTED AT 0°  
 ONE WAY EVP DETECTOR AND CONFIRMATORY LIGHT  
 LUMINAIRE-250 W HPS  
 PEDESTRIAN PUSH BUTTON AND SIGN (R10-4B)  
 2-SIGNS (R6-1L AND R6-1R)  
 EXTEND INTO HH 15  
 78 mm RSC  
 2-12/C #12  
 3-3/C #12  
 1-3/C #20

**1** PA100 POLE FOUNDATION  
 TYPE PA100-A-12.2-D12.2-2.7 (DAVIT AT 350°)  
 2-SWING AWAY HINGES  
 2-ONE WAY SIGNALS OVERHEAD AT 0 m AND 3.4 m  
 TYPE 10A POLE MOUNTED AT 90°  
 TYPE 10B POLE MOUNTED AT 180°  
 ONE WAY EVP DETECTOR AND CONFIRMATORY LIGHT  
 LUMINAIRE-250 W HPS  
 RADIO INTERCONNECT ANTENNA  
 PEDESTRIAN PUSH BUTTON AND SIGN (R10-4B)  
 2-TYPE D SIGNS (D-1 AND D-2)  
 2-SIGNS (R6-1L AND R6-1R)  
 SIGN (R9-3a) FACING PEDESTAL 6  
 EXTEND INTO HH 17  
 78 mm RSC  
 2-12/C #12  
 3-3/C #12  
 1-3/C #20  
 1-COAXIAL CABLE

**6** PEDESTAL FOUNDATION  
 4.6 m PEDESTAL POLE AND BASE  
 TYPE 6A  
 2-R9-3a SIGNS (NO PED) FACING POLES 1 & 5  
 EXTEND INTO HH 16  
 78 mm RSC  
 1-12/C #12

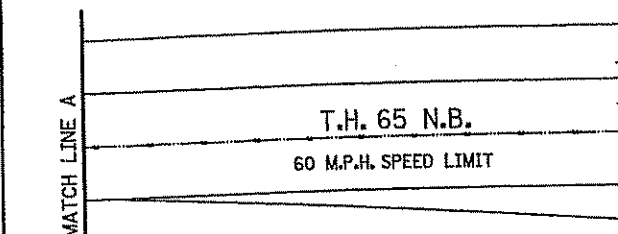

**CONTROLLER PHASING, PEDESTRIAN INDICATIONS AND PUSH BUTTONS**

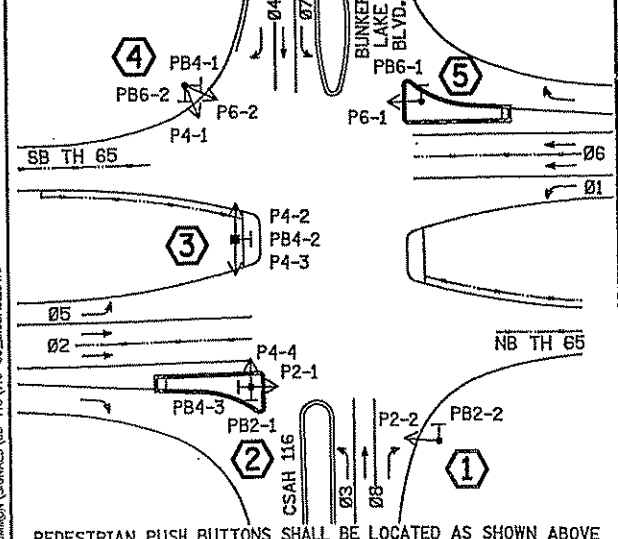

**SIGNAL SYSTEM OPERATION**  
 - THE SIGNAL SYSTEM FLASH MODE IS ALL RED.  
 - NORMAL OPERATION IS 8 PHASE. PHASES 1, 3, 5, AND 7 ARE PROTECTED LEFT TURN PHASES.  
 - PHASES 2 AND 6 SHALL BE ON VEHICLE RECALL.

DRAWN BY: JMG  
 DESIGNER: JMG  
 CHECKED BY: JMG

DESIGN TEAM	NO.	BY	DATE	REVISIONS

HEREBY CERTIFY THAT THIS PLAN WAS PREPARED BY ME OR UNDER MY DIRECT SUPERVISION AND THAT I AM A DULY LICENSED PROFESSIONAL ENGINEER UNDER THE LAWS OF THE STATE OF MINNESOTA.  
 Name: John M. Gray, PE  
 Date: May 23, 2012  
 Lic. No. 22457

SEH  
 PHONE: (651) 490-2000  
 3535 WADSWORTH CENTER DR.  
 ST. PAUL, MN 55110

ANOKA COUNTY,  
 MINNESOTA  
 CITY OF HAM LAKE

INPLACE SIGNAL SYSTEM  
 'FOR INFORMATION ONLY'  
 TRUNK HIGHWAY 65 AT CSAH 116

FILE NO.  
 ANOKC 118012  
 SIGNAL SHEET  
 88 OF 5610  
**88**  
**108**

**SIGNAL FACES**

FACE	R	Y	G	RLTA	YLTA	GLTA
1-1, 1-2				←	←	←
2-1, 2-2, 2-3	●	●	●			
3-1, 3-2				←	←	←
4-1, 4-2, 4-3	●	●	●			
5-1, 5-2				←	←	←
6-1, 6-2, 6-3	●	●	●			
7-1, 7-2				←	←	←
8-1, 8-2, 8-3	●	●	●			

EACH SIGNAL FACE SHALL HAVE A BACKGROUND SHIELD.  
 ALL SIGNAL INDICATIONS SHALL BE 300 mm.  
 ALL SIGNAL INDICATIONS SHALL BE LED.

**LOOP DETECTORS**

NUMBER	SIZE (METERS)	LOCATION
D1-1	1.7 x 1.7	12
D1-2	1.7 x 3.0	3
D2-1	1.7 x 1.7	168
D2-2	1.7 x 1.7	168
D3-1	1.7 x 1.7	12
D3-2	1.7 x 1.7	3
D4-1	1.7 x 1.7	76
D4-2	1.7x1.7, 1.7x4.6	AS SHOWN
D4-3	2-1.7 x 1.7	1.5 & 6
D5-1	1.7 x 1.7	12
D5-2	1.7 x 3.0	3
D6-1	1.7 x 1.7	168
D6-2	1.7 x 1.7	168
D7-1	1.7 x 1.7	12
D7-2	1.7 x 1.7	3
D8-1	1.7 x 1.7	76
D8-2	1.7x1.7, 1.7x4.6	AS SHOWN
D8-3	2-1.7 x 1.7	1.5 & 6

LOCATION = DISTANCE FROM STOP LINE OR CROSSWALK TO DETECTOR IN METERS

NOTE: THIS PLAN SHEET IS BEING PROVIDED FOR INFORMATIONAL PURPOSES ONLY.

S.P. 0208-145  
 S.A.P. 002-716-013

S:\VEVA\ANOKA\COMMON SIGNALS\65-116\116-65\_SIBASE.DWG



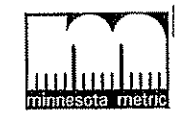
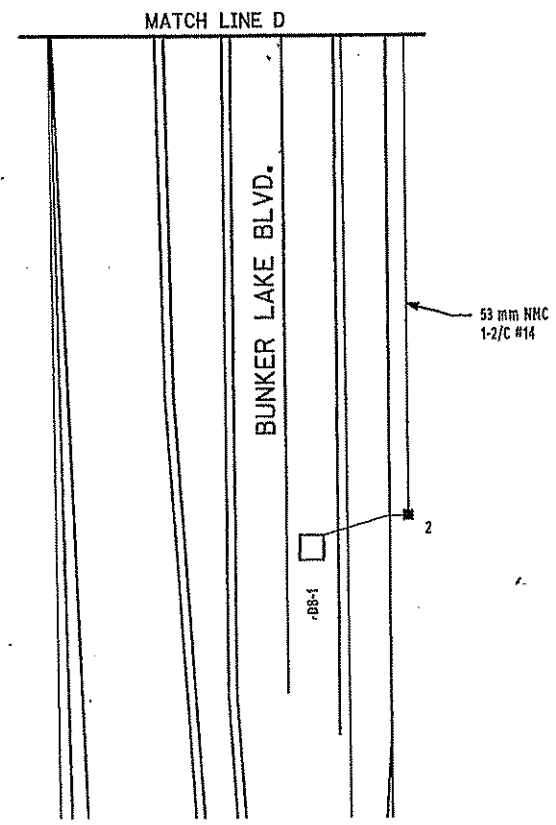
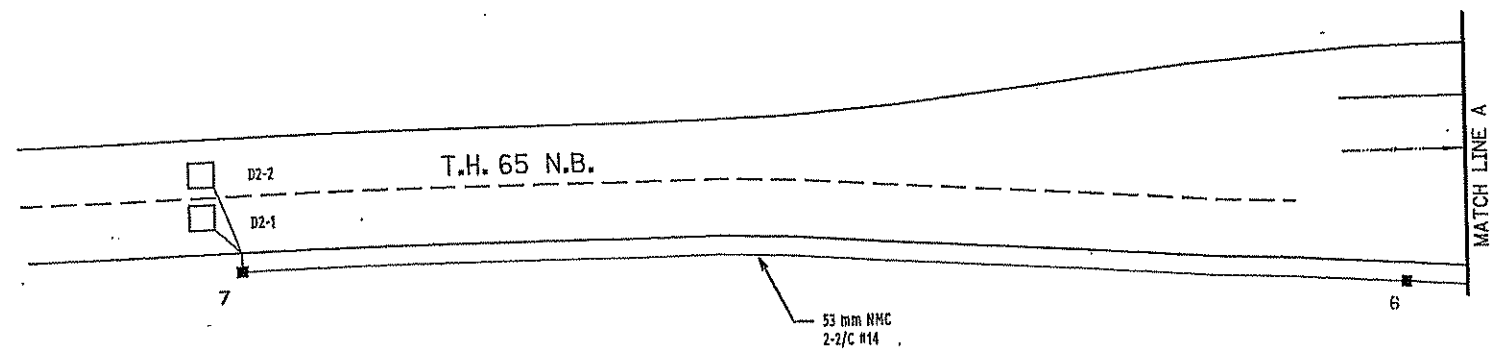
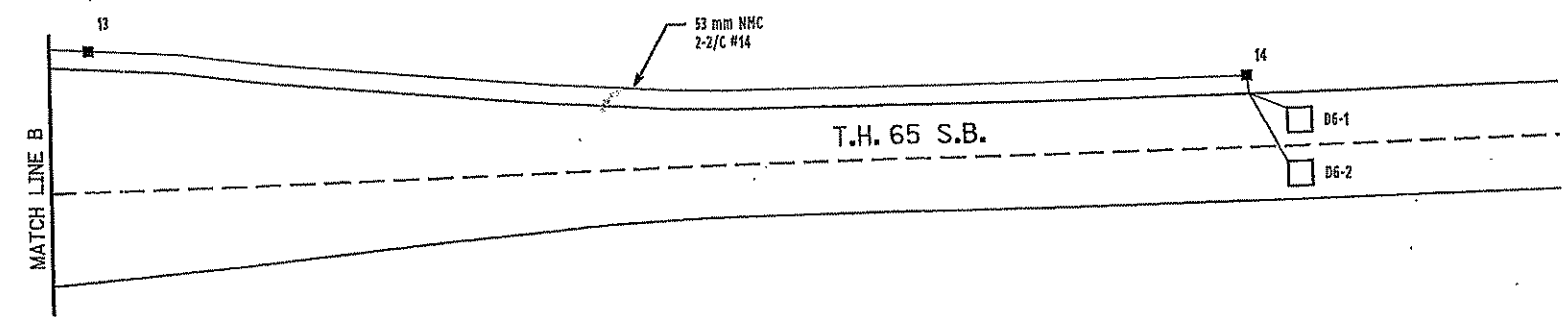
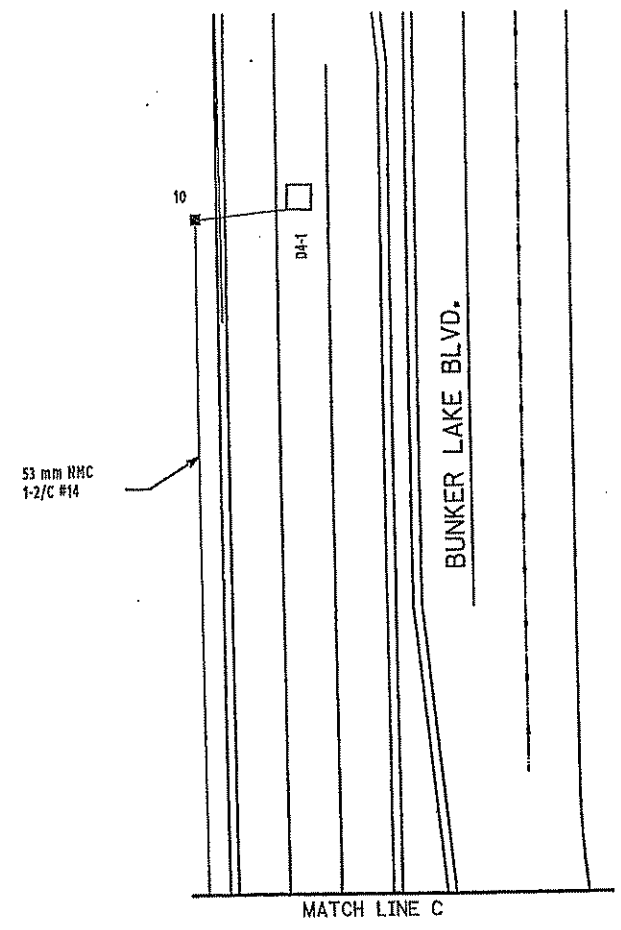
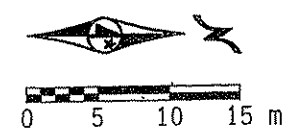

SYSTEM I.D.: 21180  
METER ADDRESS: 13701 HWY. 65

NOTE: THIS PLAN SHEET IS BEING PROVIDED FOR INFORMATIONAL PURPOSES ONLY.

S.P. 0208-145  
S.A.P. 002-716-013

S:\A\ANOKA\COUNTY SIGNALS\65-116\116-65\_SIBASE.DWG

DRAWN BY: JMG			
DESIGNER: JMG			
CHECKED BY: JMG			
DESIGN TEAM	NO.	BY	DATE
			REVISIONS

I HEREBY CERTIFY THAT THIS PLAN WAS PREPARED BY ME OR UNDER MY DIRECT SUPERVISION AND THAT I AM A DULY LICENSED PROFESSIONAL ENGINEER UNDER THE LAWS OF THE STATE OF MINNESOTA.

*John M. Gray*  
Name: John M. Gray, PE  
Date: May 23, 2012  
Lic. No. 22457

**SEH**  
PHONE: (651) 490-2000  
3535 VADNAIS CENTER DR.  
ST. PAUL, MN 55110

**ANOKA COUNTY, MINNESOTA**  
CITY OF HAM LAKE

**INPLACE SIGNAL SYSTEM**  
"FOR INFORMATION ONLY"  
TRUNK HIGHWAY 65 AT CSAH 116

FILE NO. ANOKC 119012	<b>89</b>
SIGNAL SHEET 509 OF 509	

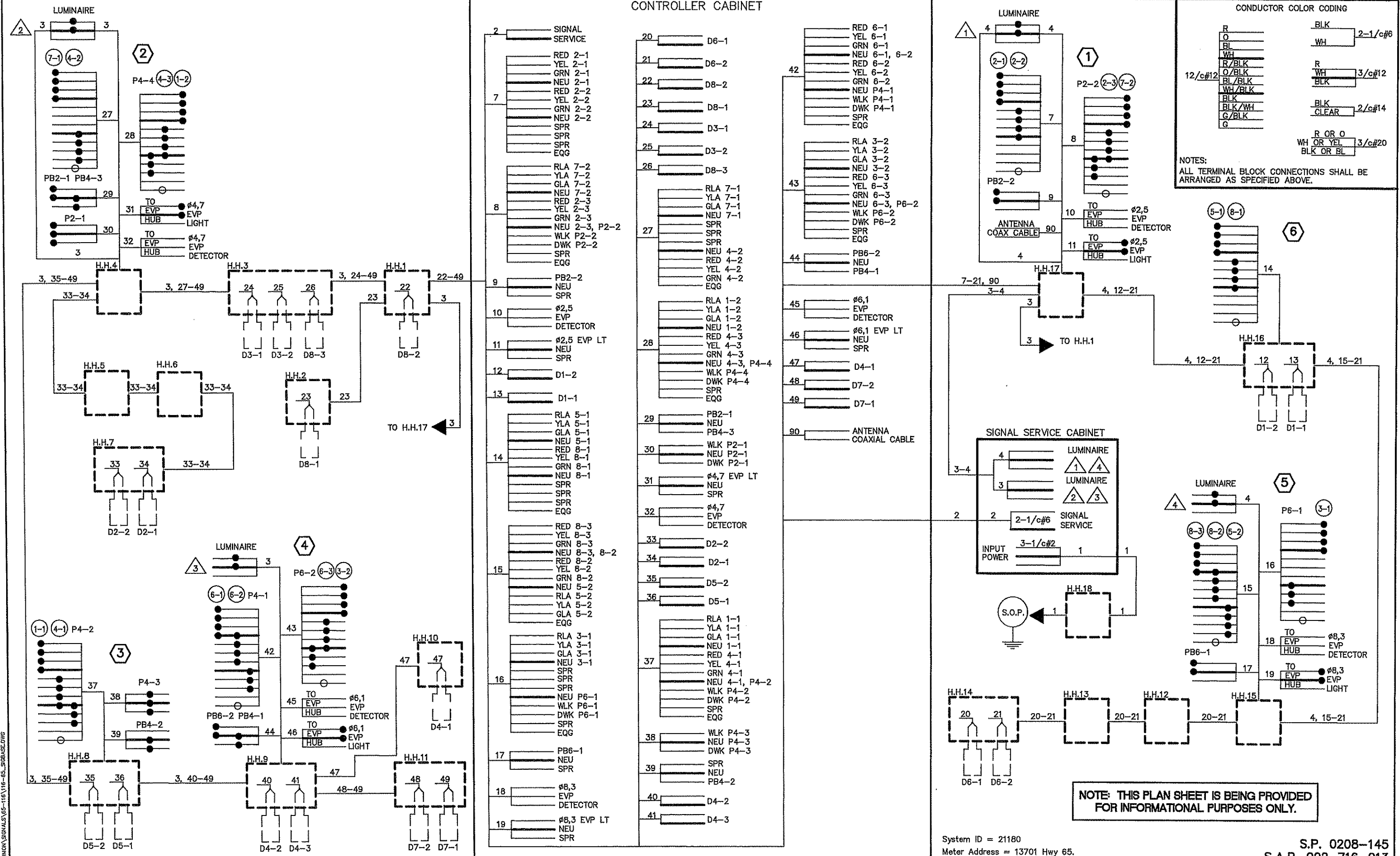

DRAWN BY: JMG  
 DESIGNER: JMG  
 CHECKED BY: JMG

DESIGN TEAM	NO.	BY	DATE	REVISIONS

HEREBY CERTIFY THAT THIS PLAN WAS PREPARED BY ME OR UNDER MY DIRECT SUPERVISION AND THAT I AM A DULY LICENSED PROFESSIONAL ENGINEER UNDER THE LAWS OF THE STATE OF MINNESOTA.

*John M. Gray*  
 Name: John M. Gray, PE  
 Date: May 23, 2012  
 Lic. No. 22457

**SEH**  
 PHONE: (651) 490-2000  
 3535 WADNAIS CENTER DR.  
 ST. PAUL, MN 55110

**ANOKA COUNTY, MINNESOTA**  
 CITY OF HAM LAKE

**INPLACE SIGNAL SYSTEM**  
 'FOR INFORMATION ONLY'  
 TRUNK HIGHWAY 65 AT CSAH 116

System ID = 21180  
 Meter Address = 13701 Hwy 65.

FILE NO. ANOKC 119012  
 SIGNAL SHEET SG10 OF SG10

**90**  
**108**

S:\A\VA\WORK\COMMON SIGNALS\65-116\116-65\_SGRASE.DWG

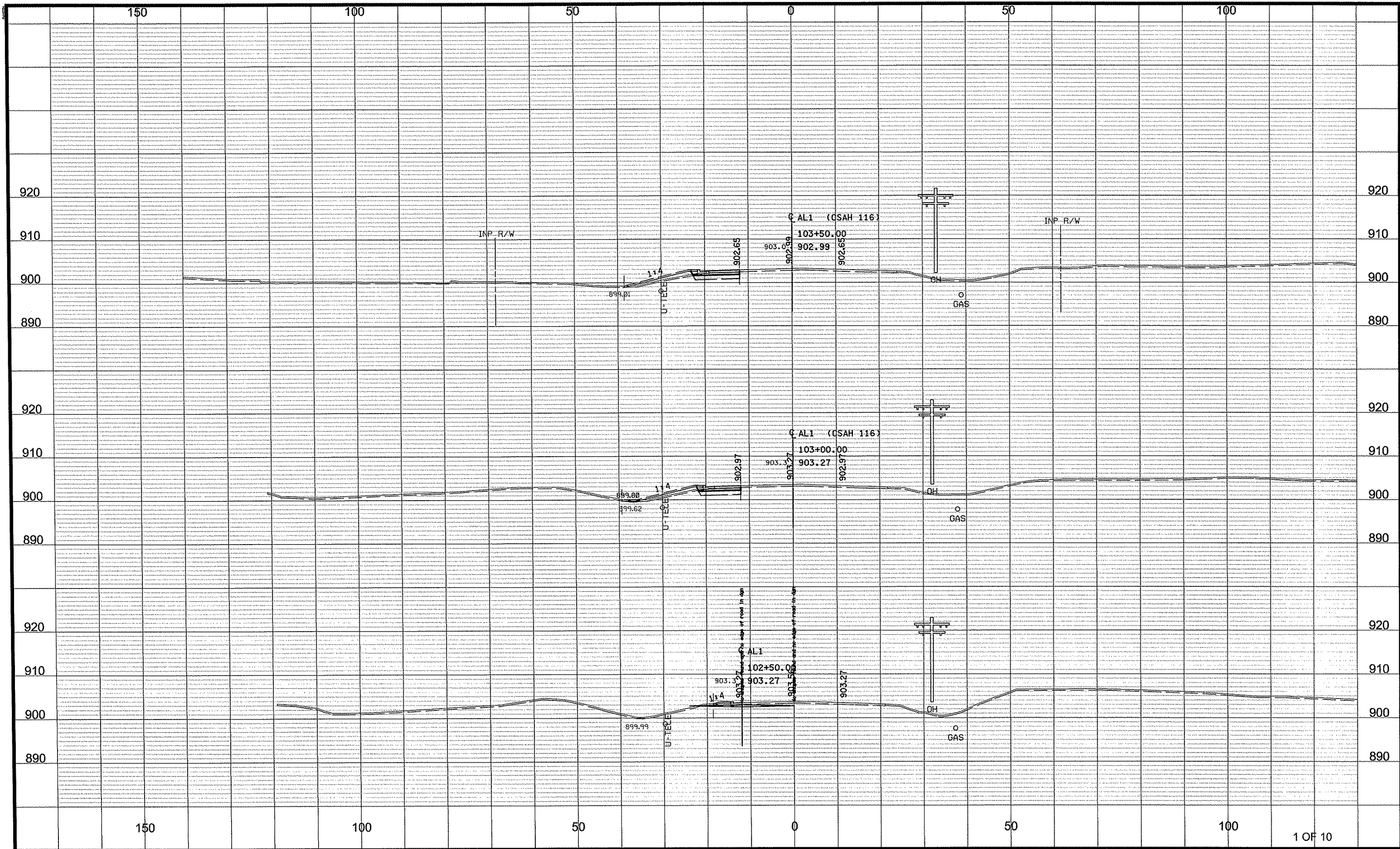

NO	DATE	BY	CKD	APPR	REVISION

NAME: p116-65\plan116-65\_XS1\_WB116.dgn  
05/23/2012 9:46:41 AM

DRAWN BY BAV DATE 3-23-12  
 DESIGN BY BAV DATE 3-23-12  
 CHECKED BY JEO DATE 4-10-12



**ANOKA COUNTY**  
**HIGHWAY DEPT.**

S.P. 0208-145 (T.H. 65)  
 S.A.P. 002-716-013  
 S.A.P. 197-020-004

**CSAH 116 CROSS SECTIONS**  
 STA 102+50.00 TO 103+50.00  
 Sheet 91 of 108 Sheets

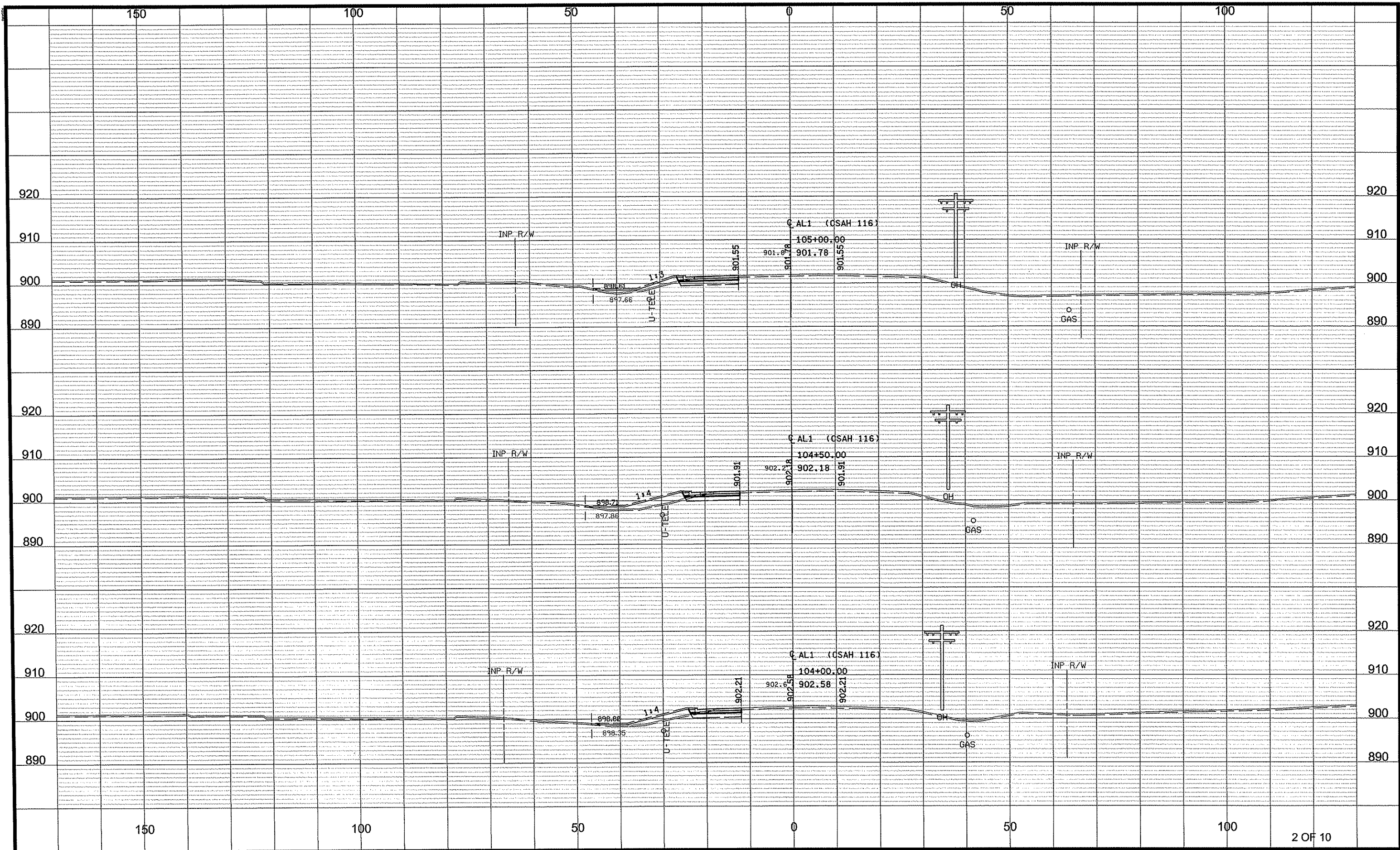

DRAWN BY BAV DATE 3-23-12  
 DESIGN BY BAV DATE 3-23-12  
 CHECKED BY JEO DATE 4-10-12



**ANOKA COUNTY**  
**HIGHWAY DEPT.**

S.P. 0208-145 (T.H. 65)  
 S.A.P. 002-716-013  
 S.A.P. 197-020-004

**CSAH 116 CROSS SECTIONS**  
 STA 104+00.00 TO 105+00.00  
 Sheet 92 of 108 Sheets

NO	DATE	BY	CKD	APPR	REVISION

NAME: p116-65plan116-65\_XS1\_WB116.dgn  
 05/23/2012 9:46:42 AM

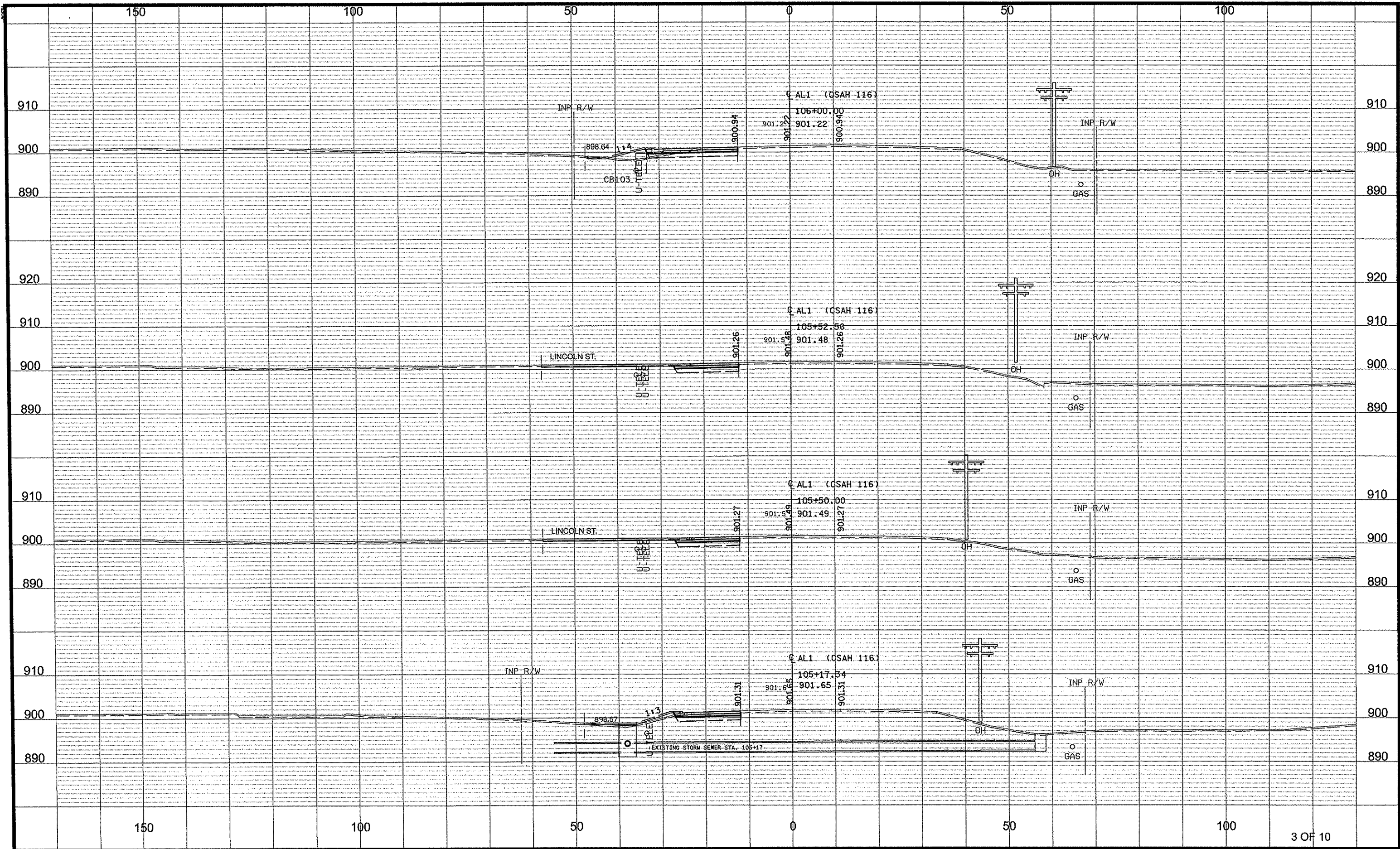

NO	DATE	BY	CKD	APPR	REVISION

NAME: p116-65.plant116-65\_XS1\_WB116.dgn 05/23/2012 9:46:43 AM

DRAWN BY BAV DATE 3-23-12  
 DESIGN BY BAV DATE 3-23-12  
 CHECKED BY JEO DATE 4-10-12



**ANOKA COUNTY**  
**HIGHWAY DEPT.**

S.P. 0208-145 (T.H. 65)  
 S.A.P. 002-716-013  
 S.A.P. 197-020-004

CSAH 116 CROSS SECTIONS  
 STA 105+17.34 TO 106+00.00  
 Sheet 93 of 108 Sheets

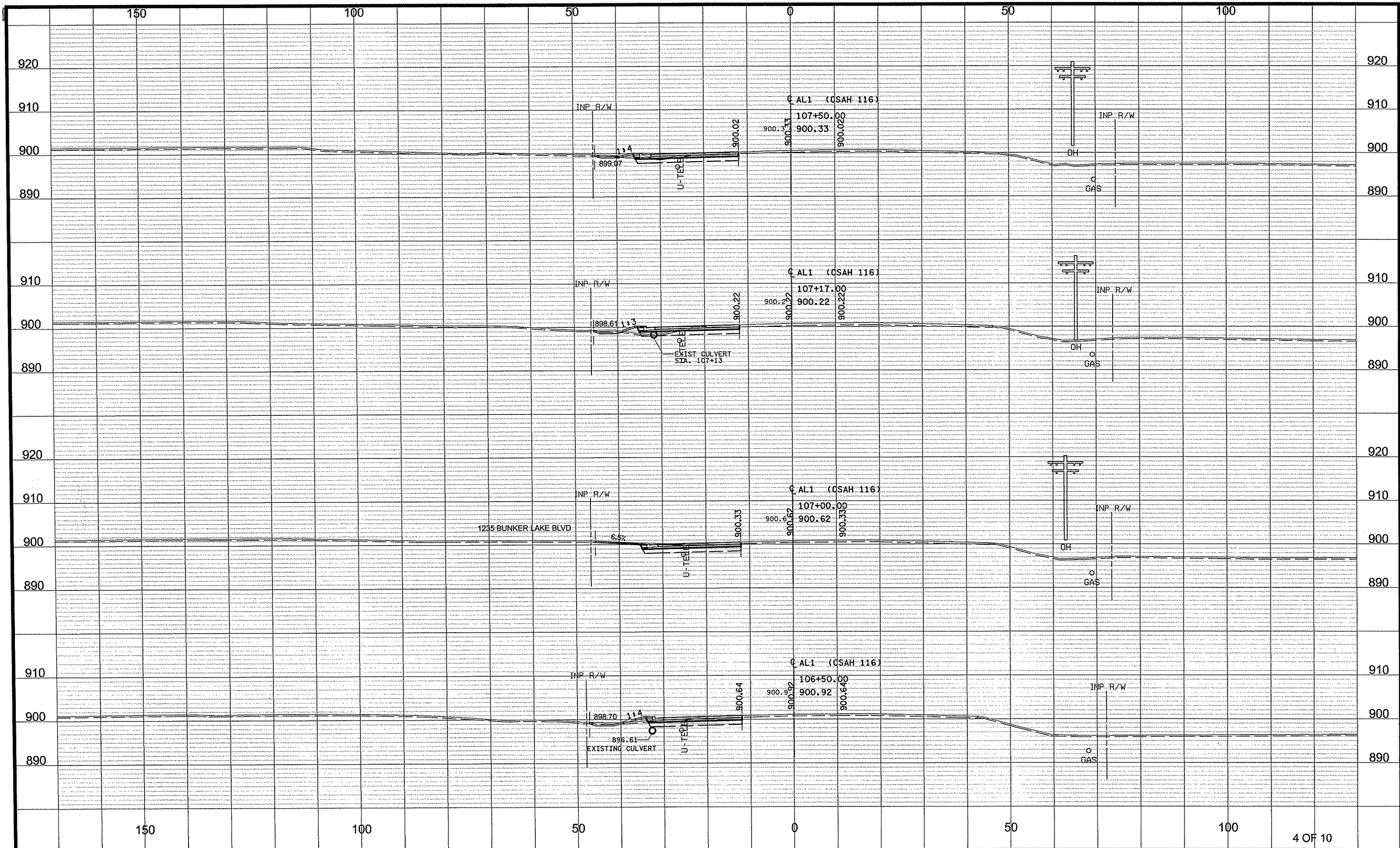

NO	DATE	BY	CKD	APPR	REVISION
NAME: p:116-65\plan116-65_XS1_WB116.dgn					
					05/23/2012
					9:46:44 AM

DRAWN BY BAV DATE 3-23-12  
 DESIGN BY BAV DATE 3-23-12  
 CHECKED BY JED DATE 4-10-12



**ANOKA COUNTY**  
**HIGHWAY DEPT.**

S.P. 0208-145 (T.H. 65)  
 S.A.P. 002-716-013  
 S.A.P. 197-020-004

**CSAH 116 CROSS SECTIONS**  
 STA 106+50.00 TO 107+50.00  
 Sheet 94 of 108 Sheets

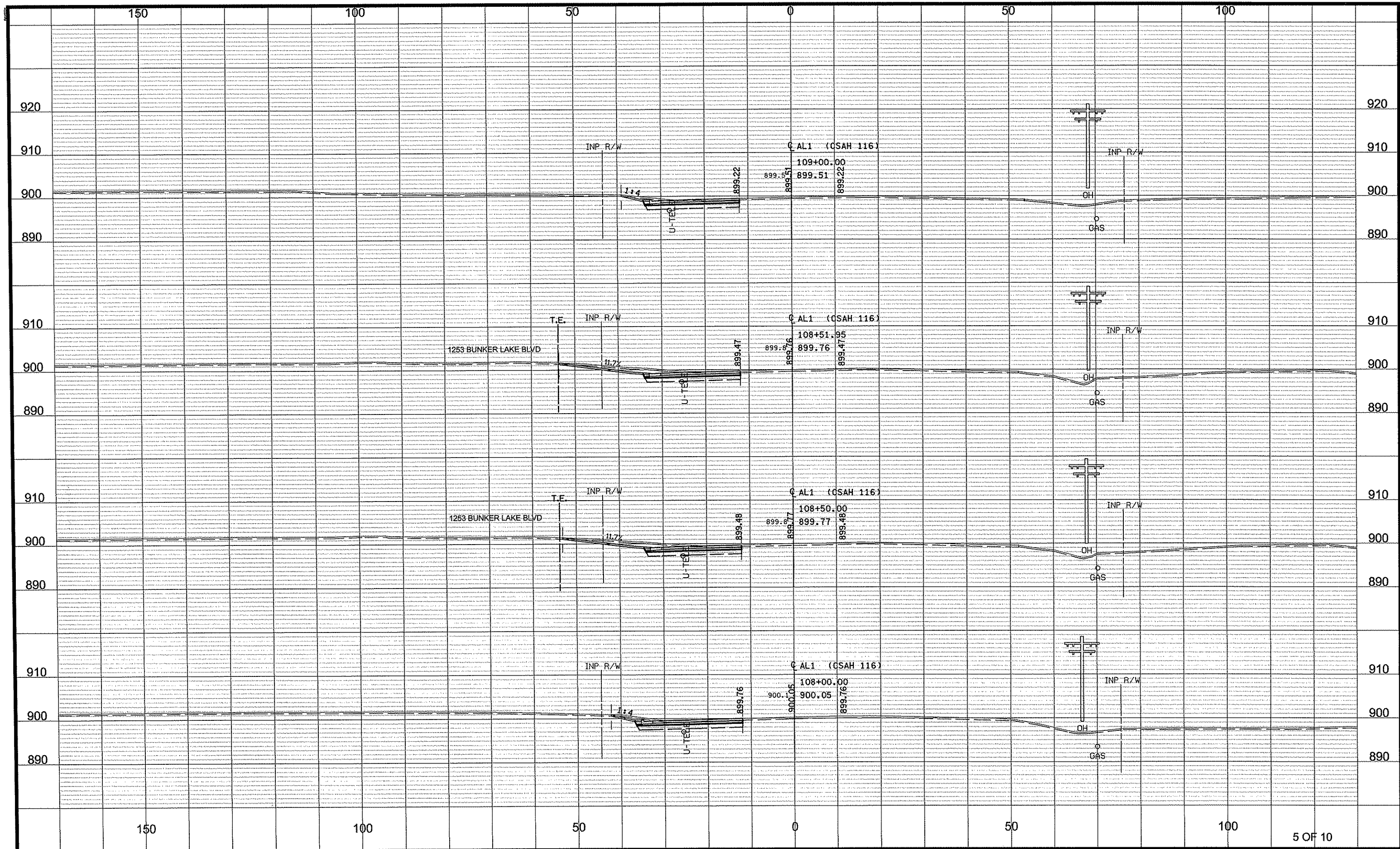

5 OF 10

NO	DATE	BY	CKD	APPR	REVISION
NAME: p1116-65plan116-65_XS1_WB116.dgn					
					05/23/2012
					9:48:45 AM

DRAWN BY BAV DATE 3-23-12  
 DESIGN BY BAV DATE 3-23-12  
 CHECKED BY JEO DATE 4-10-12



**ANOKA COUNTY**  
**HIGHWAY DEPT.**

S.P. 0208-145 (T.H. 65)  
 S.A.P. 002-716-013  
 S.A.P. 197-020-004

**CSAH 116 CROSS SECTIONS**  
 STA 108+00.00 TO 109+00.00  
 Sheet 95 of 108 Sheets

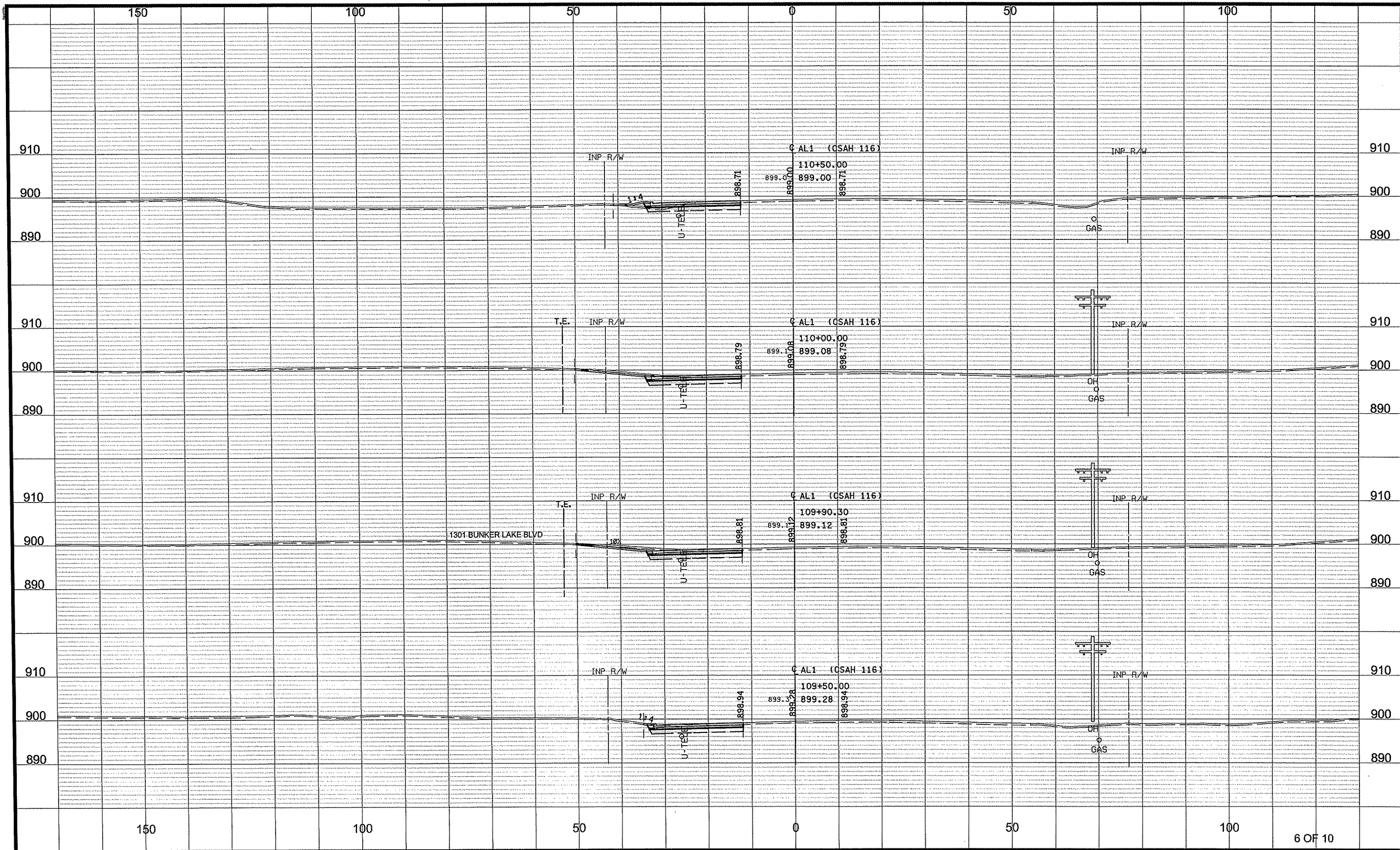

6 OF 10

NO	DATE	BY	CKD	APPR	REVISION
NAME: p116-65plan116-65_XS1_WB116.dgn					
05/23/2012 9:46:46 AM					

DRAWN BY BAV DATE 3-23-12  
 DESIGN BY BAV DATE 3-23-12  
 CHECKED BY JEO DATE 4-10-12



**ANOKA COUNTY**  
**HIGHWAY DEPT.**

S.P. 0208-145 (T.H. 65)  
 S.A.P. 002-716-013  
 S.A.P. 197-020-004

**CSAH 116 CROSS SECTIONS**  
 STA 109+50.00 TO 110+50.00  
 Sheet 96 of 108 Sheets



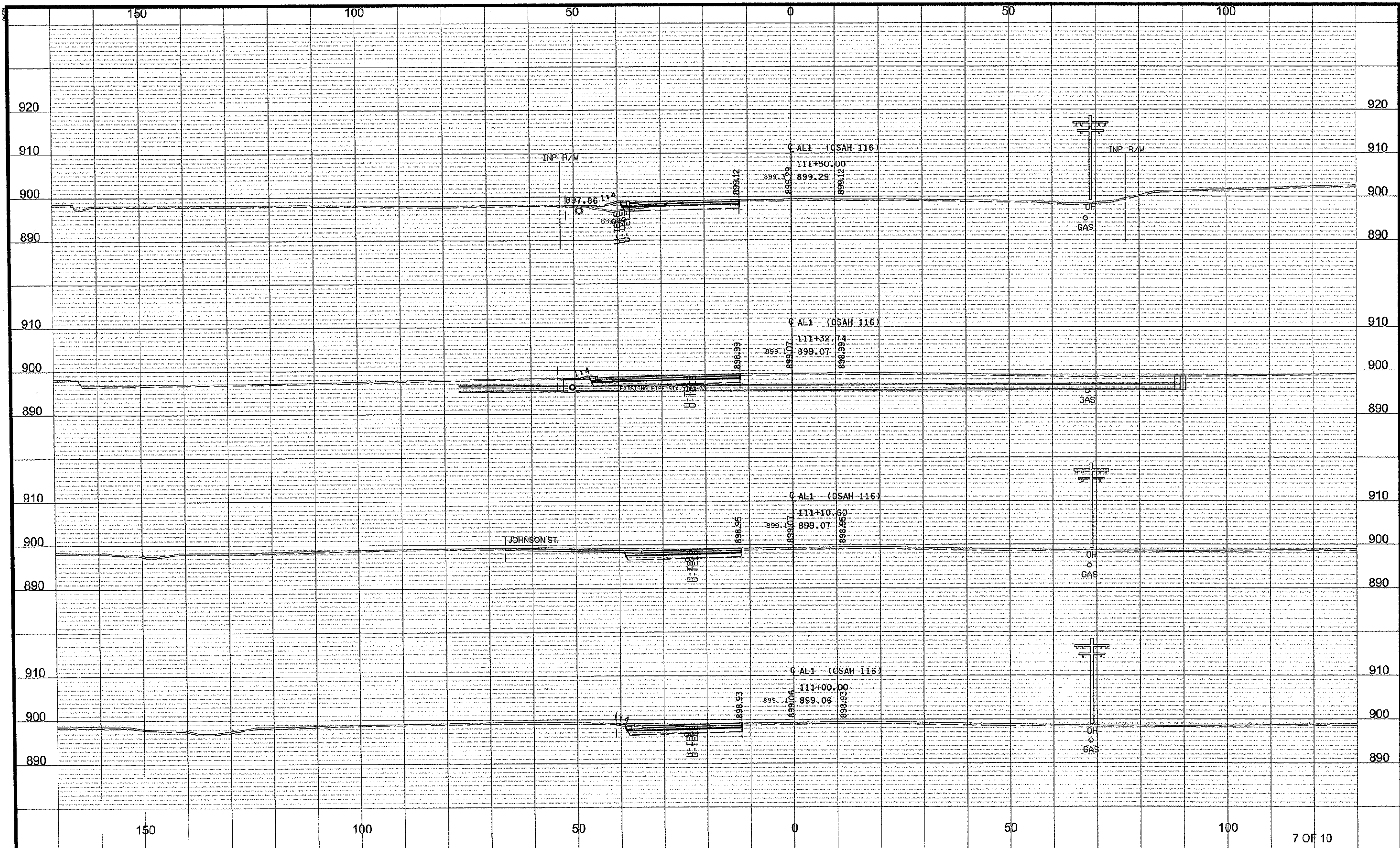

NO	DATE	BY	CKD	APPR	REVISION
NAME: p:116-65\plan116-65_XSI_WB116.dgn					
					05/23/2012
					9:46:47 AM

DRAWN BY BAV DATE 3-23-12  
 DESIGN BY BAV DATE 3-23-12  
 CHECKED BY JEO DATE 4-10-12



**ANOKA COUNTY**  
**HIGHWAY DEPT.**

S.P. 0208-145 (T.H. 65)  
 S.A.P. 002-716-013  
 S.A.P. 197-020-004

**CSAH 116 CROSS SECTIONS**  
 STA 111+00.00 TO 111+50.00  
 Sheet 97 of 108 Sheets

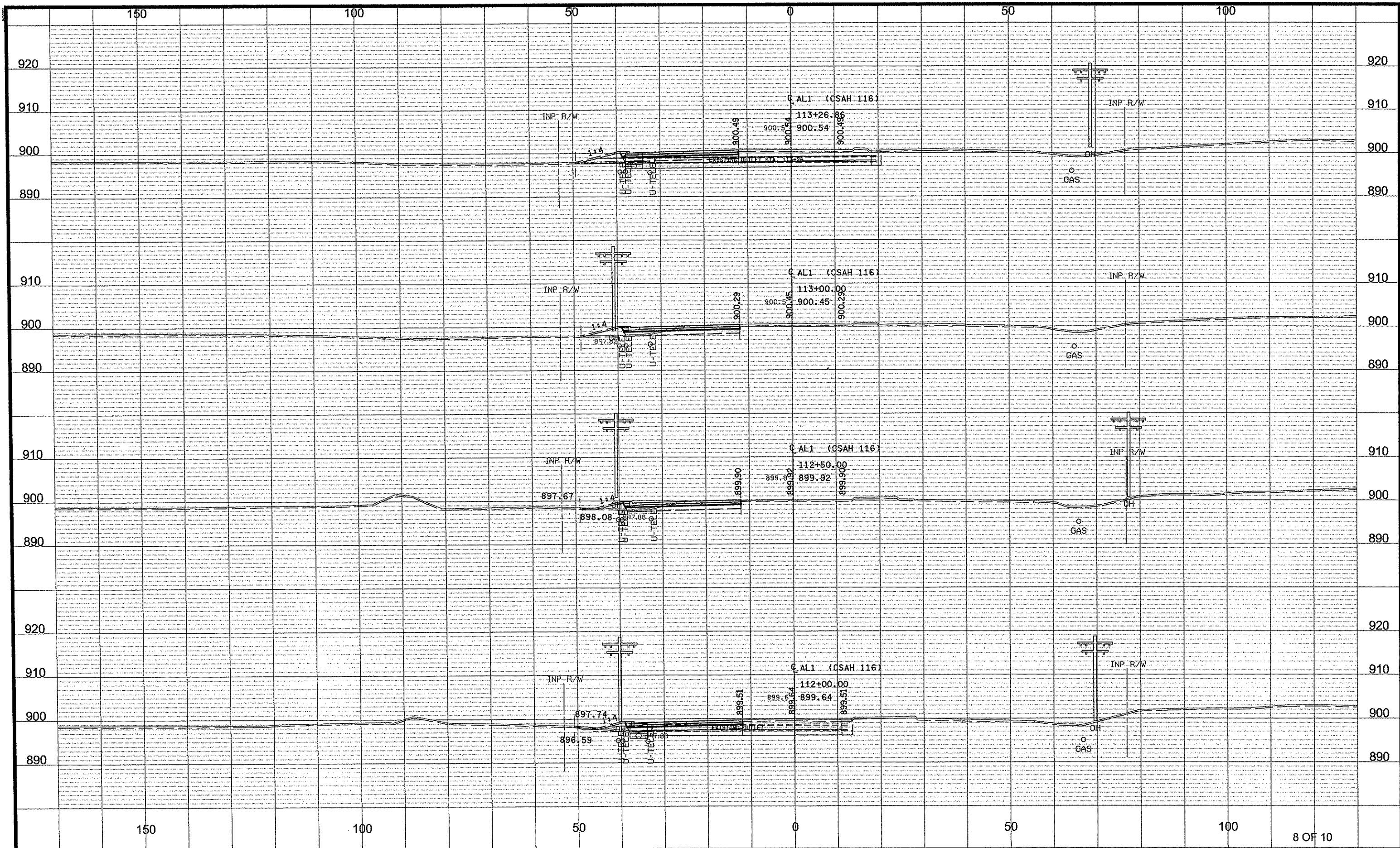

NO	DATE	BY	CKD	APPR	REVISION
NAME: p:116-65\plan116-65_XS1 WB116.dgn					
					05/23/2012
					9:46:48 AM

DRAWN BY BAV DATE 3-23-12  
 DESIGN BY BAV DATE 3-23-12  
 CHECKED BY JEO DATE 4-10-12



**ANOKA COUNTY**  
**HIGHWAY DEPT.**

S.P. 0208-145 (T.H. 65)  
 S.A.P. 002-716-013  
 S.A.P. 197-020-004

**CSAH 116 CROSS SECTIONS**  
 STA 112+00.00 TO 113+26.86  
 Sheet 98 of 108 Sheets

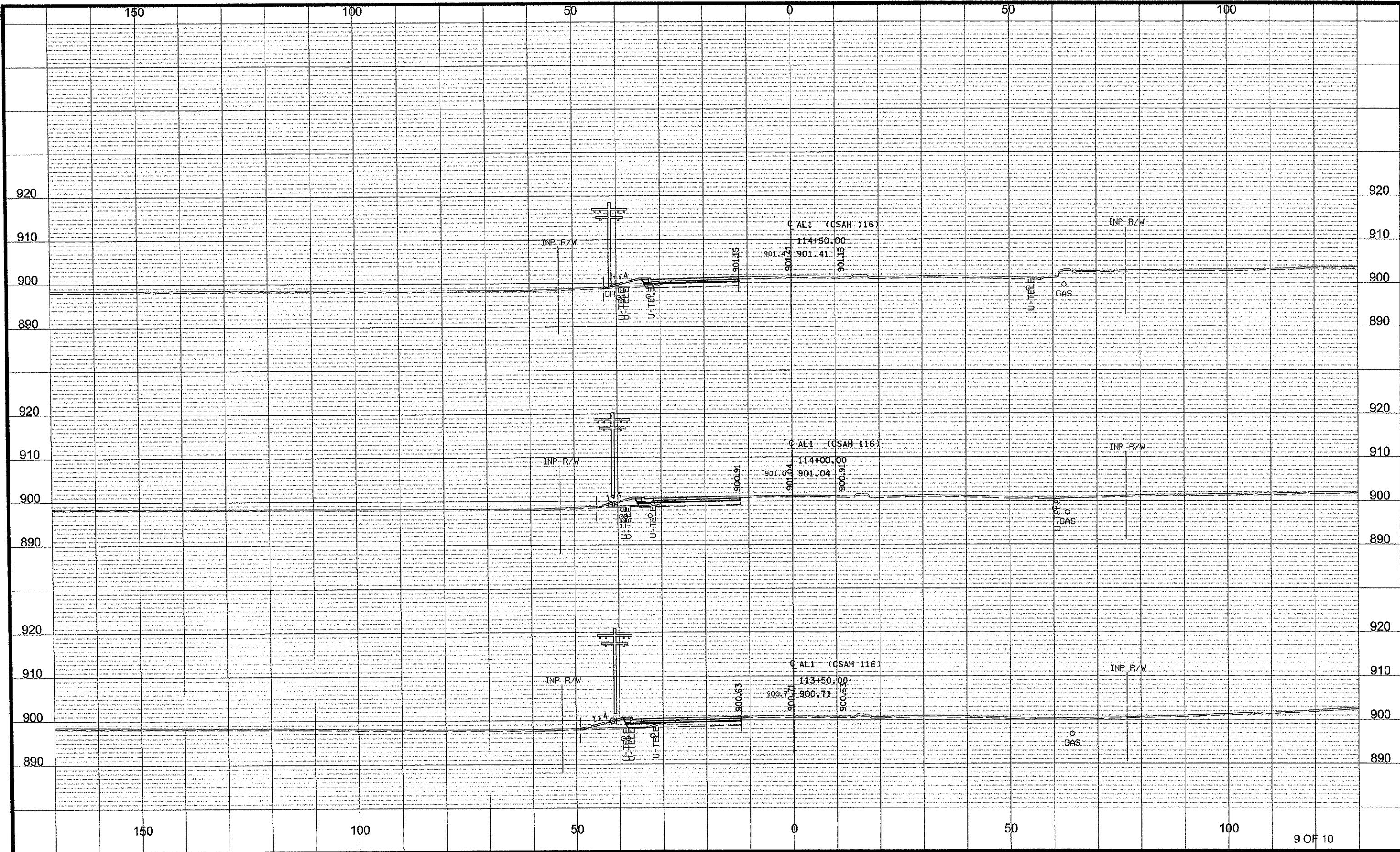

NO	DATE	BY	CKD	APPR	REVISION
NAME: p:\116-65\plan116-65_XS1_WB116.dgn					

DRAWN BY BAV DATE 3-23-12  
 DESIGN BY BAV DATE 3-23-12  
 CHECKED BY JEO DATE 4-10-12



**ANOKA COUNTY**  
**HIGHWAY DEPT.**

S.P. 0208-145 (T.H. 65)  
 S.A.P. 002-716-013  
 S.A.P. 197-020-004

**CSAH 116 CROSS SECTIONS**  
 STA 113+50.00 TO 114+50.00  
 Sheet 99 of 108 Sheets

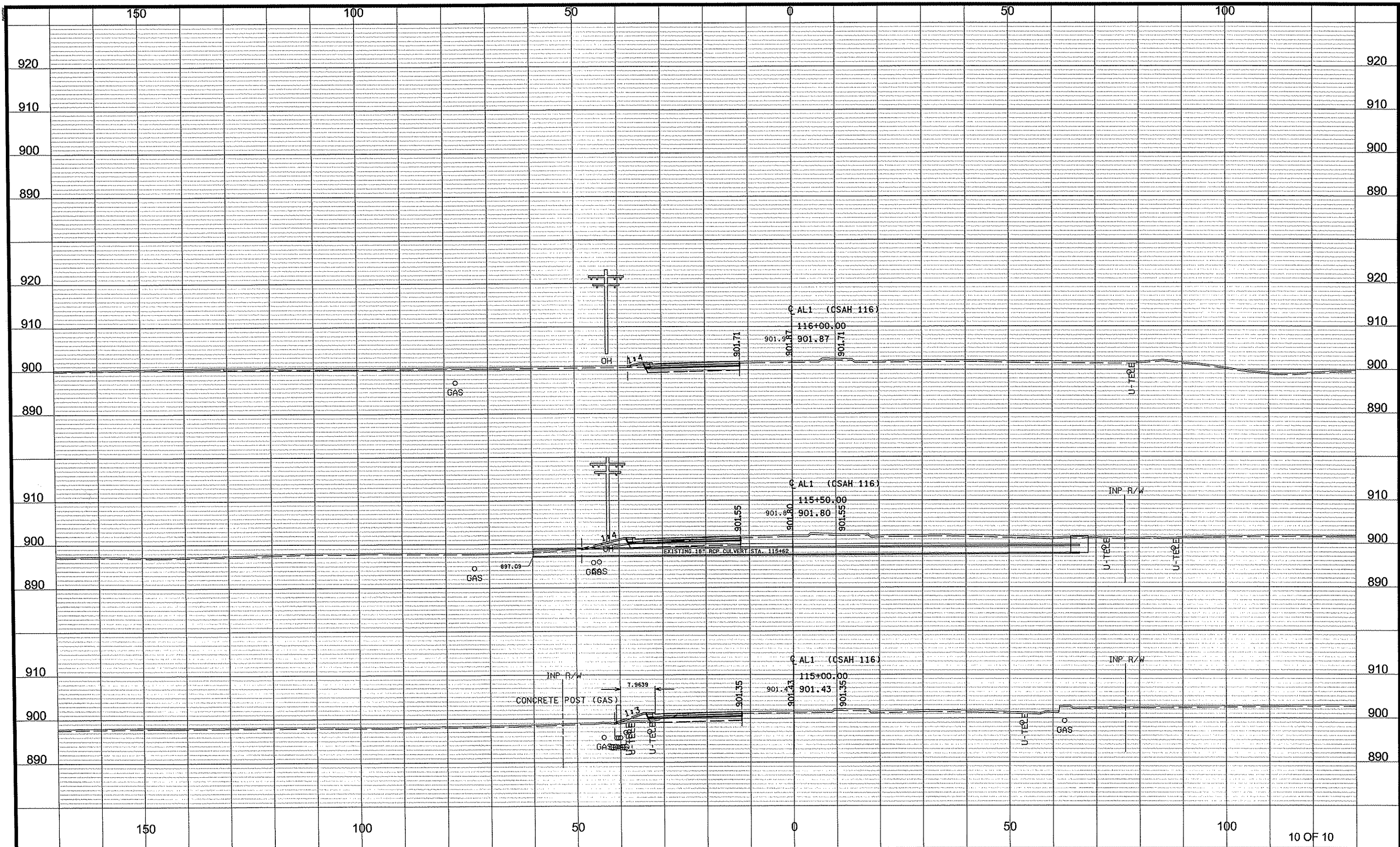

NO	DATE	BY	CKD	APPR	REVISION
NAME: p116-65.plm116-65_XS1_WB116.dgn					
					05/23/2012
					9:46:50 AM

DRAWN BY BAV DATE 3-23-12  
 DESIGN BY BAV DATE 3-23-12  
 CHECKED BY JEO DATE 4-10-12



**ANOKA COUNTY**  
**HIGHWAY DEPT.**

S.P. 0208-145 (T.H. 65)  
 S.A.P. 002-716-013  
 S.A.P. 197-020-004

**CSAH 116 CROSS SECTIONS**  
 STA 115+00.00 TO 116+00.00  
 Sheet 100 of 108 Sheets

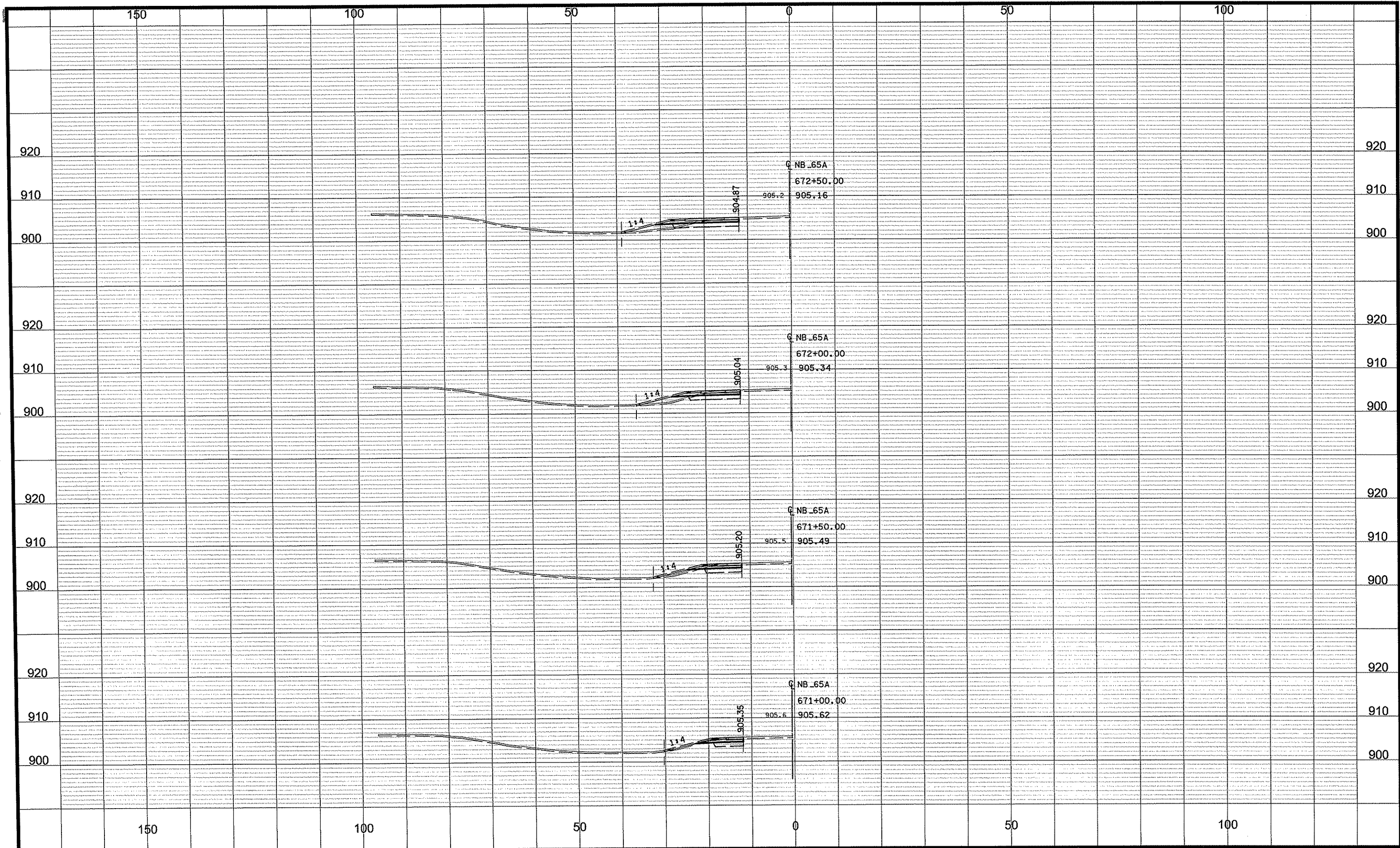

NO	DATE	BY	CKD	APPR	REVISION	
NAME: p:\116-65\plan\116-65_XS_NB65.dgn					05/23/2012	9:46:53 AM

DRAWN BY BAV DATE 3-23-12  
 DESIGN BY BAV DATE 3-23-12  
 CHECKED BY JEO DATE 4-10-12



**ANOKA COUNTY**  
**HIGHWAY DEPT.**

S.P. 0208-145 (T.H. 65)  
 S.A.P. 002-716-013  
 S.A.P. 197-020-004

**NB T.H. 65 CROSS SECTIONS**  
 STA 671+00.00 TO 672+50.00  
 Sheet 101 of 108 Sheets

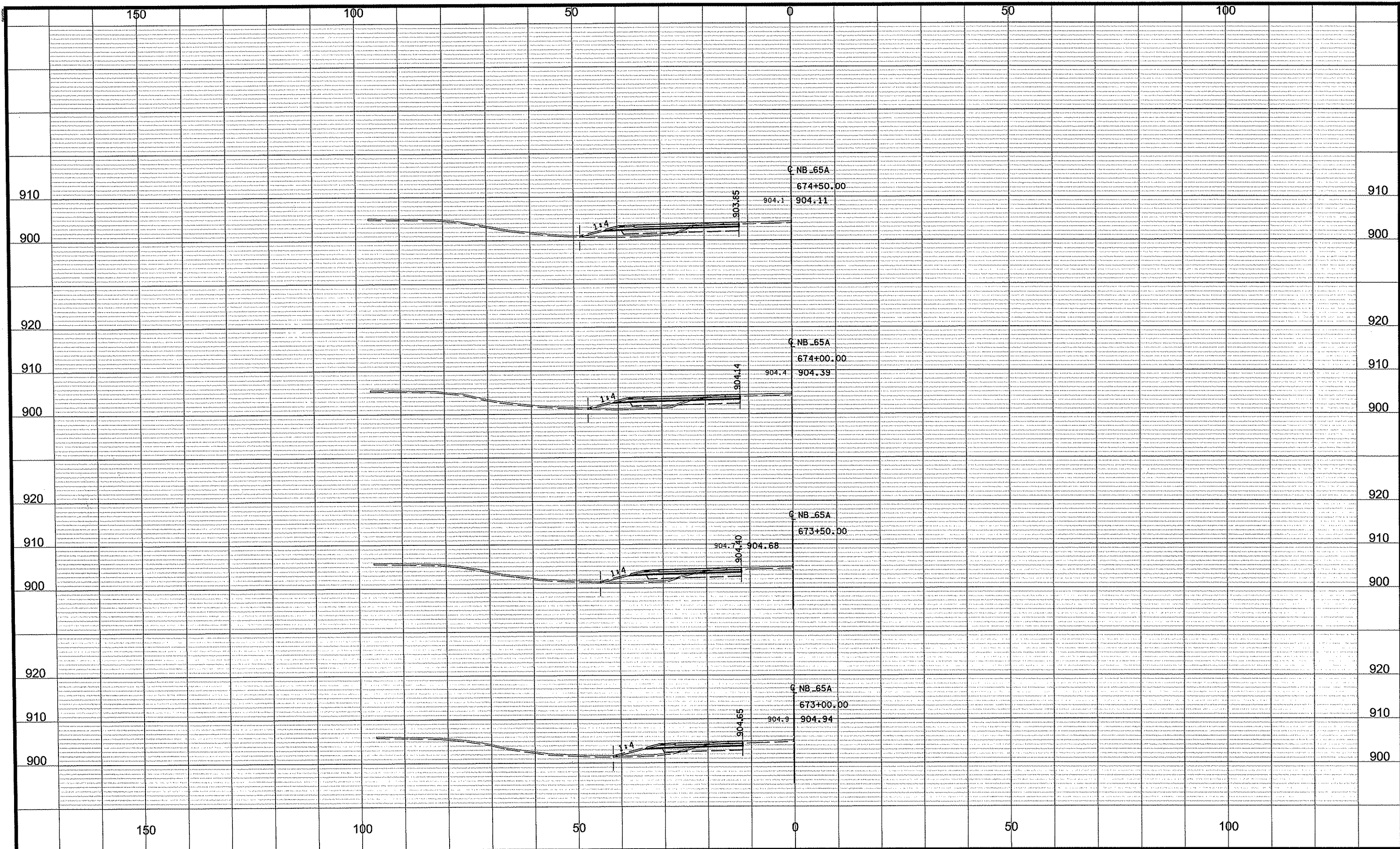

NO	DATE	BY	CKD	APPR	REVISION
NAME: p1116-65plant116-65_XS_NB65.dgn					

9:46:54 AM	05/23/2012
DESIGN BY BAV	DATE 3-23-12
CHECKED BY JEO	DATE 4-10-12

**ANOKA COUNTY**  
 HIGHWAY DEPT.

S.P. 0208-145 (T.H. 65)  
 S.A.P. 002-716-013  
 S.A.P. 197-020-004

**NB T.H. 65 CROSS SECTIONS**  
 STA 673+00.00 TO 674+50.00  
 Sheet 102 of 108 Sheets

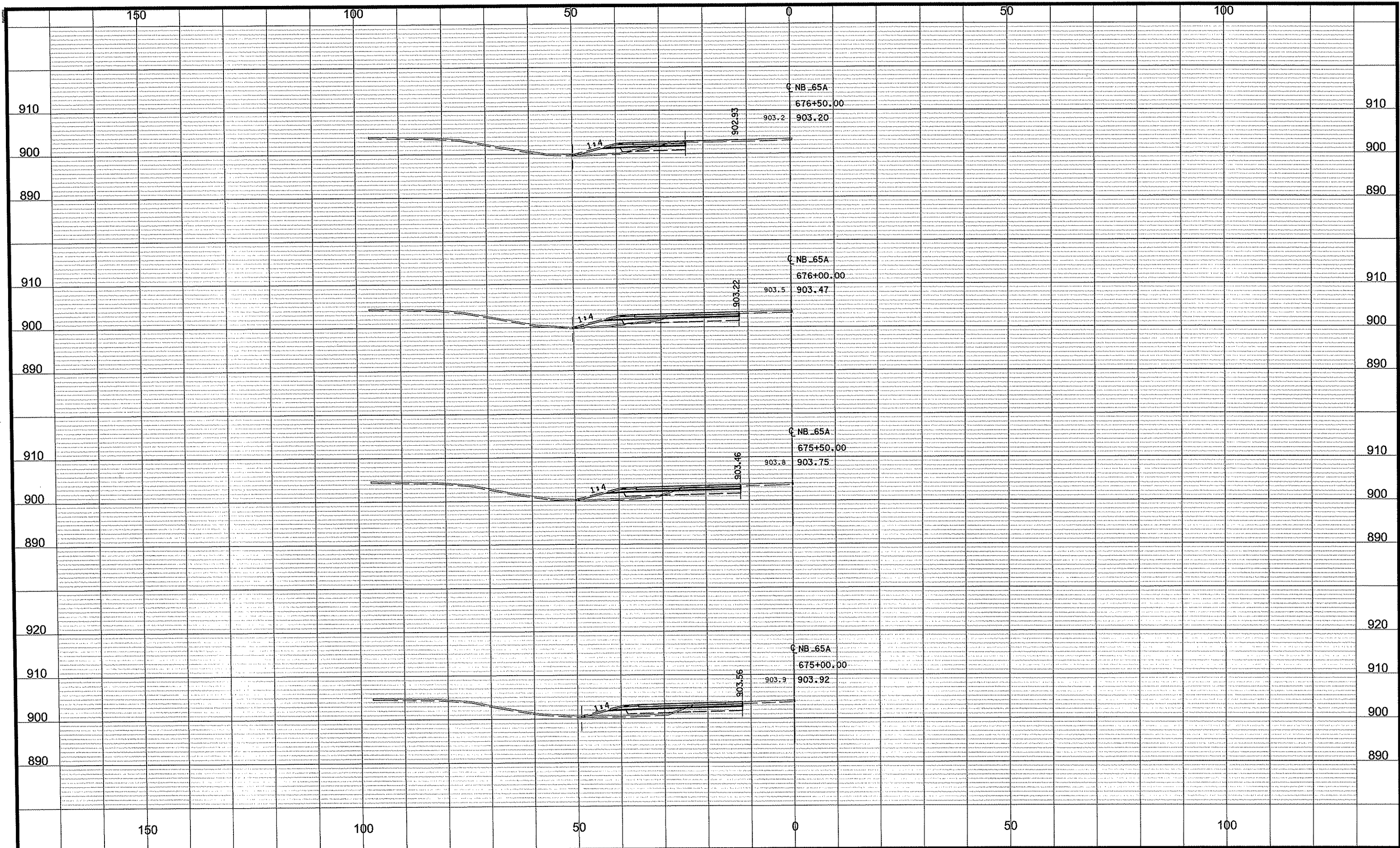

NO	DATE	BY	CKD	APPR	REVISION
NAME: p1116-65plan116-65_XS_NB65.dgn					05/23/2012
					9:46:55 AM

DRAWN BY BAV DATE 3-23-12  
 DESIGN BY BAV DATE 3-23-12  
 CHECKED BY JEO DATE 4-10-12



**ANOKA COUNTY**  
**HIGHWAY DEPT.**

S.P. 0208-145 (T.H. 65)  
 S.A.P. 002-716-013  
 S.A.P. 197-020-004

**NB T.H. 65 CROSS SECTIONS**  
 STA 675+00.00 TO 676+50.00  
 Sheet 103 of 108 Sheets

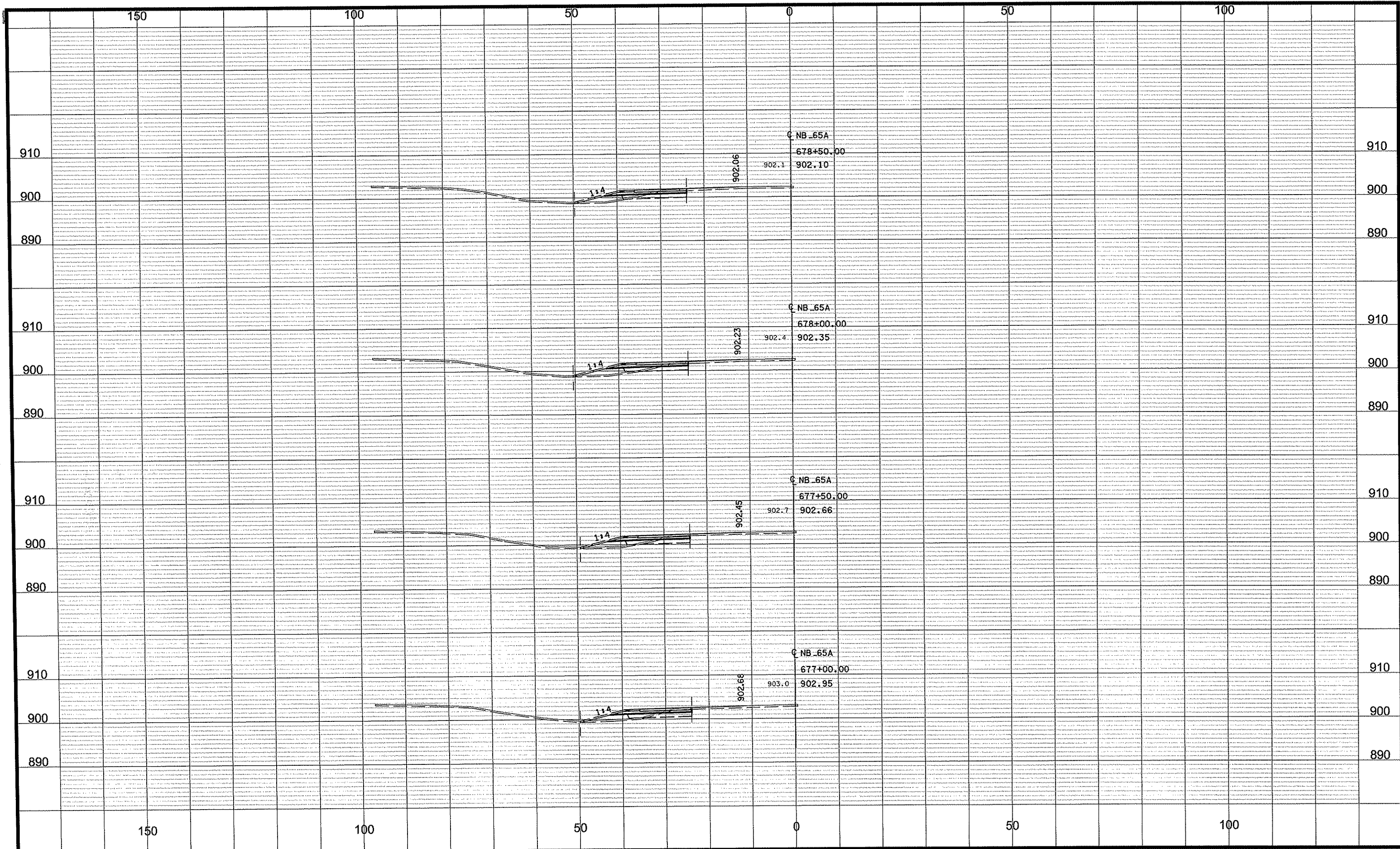

NO	DATE	BY	CKD	APPR	REVISION
NAME: p:\116-65\plan\116-65_XS_NB65.dgn					

DRAWN BY BAV DATE 3-23-12  
 DESIGN BY BAV DATE 3-23-12  
 CHECKED BY JEO DATE 4-10-12



**ANOKA COUNTY**  
**HIGHWAY DEPT.**

S.P. 0208-145 (T.H. 65)  
 S.A.P. 002-716-013  
 S.A.P. 197-020-004

**NB T.H. 65 CROSS SECTIONS**  
 STA 677+00.00 TO 678+50.00  
 Sheet 104 of 108 Sheets



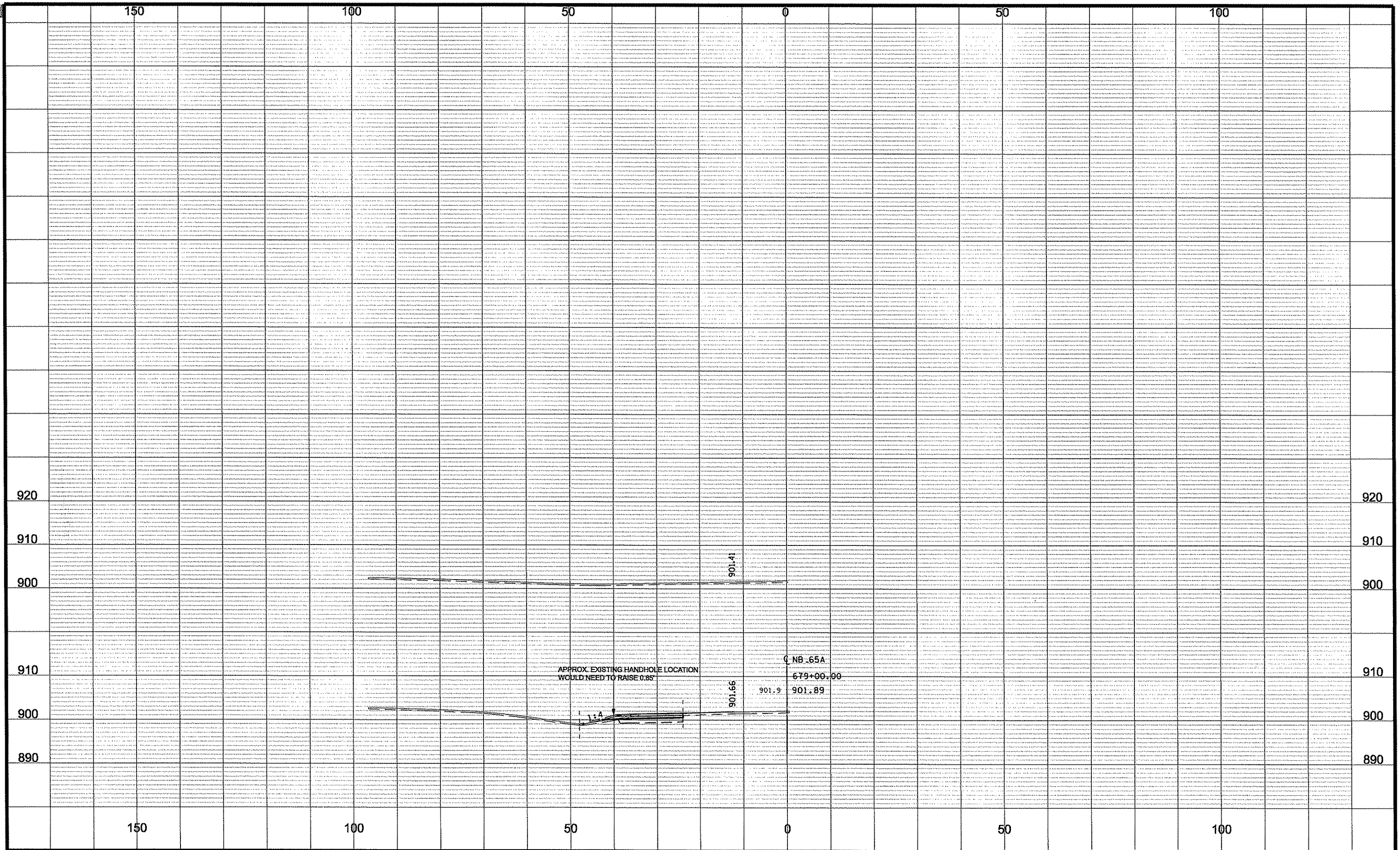

APPROX. EXISTING HANDHOLE LOCATION  
WOULD NEED TO RAISE 0.85'

C NB 65A

679+00.00

901.9

901.89

901.66



NO	DATE	BY	CKD	APPR	REVISION
NAME: P:116-65Plan116-65_XS_NB85.dgn					
					06/28/2012
					11:32:58 AM

DRAWN BY BAV DATE 3-23-12  
 DESIGN BY BAV DATE 3-23-12  
 CHECKED BY JEO DATE 4-10-12



ANOKA COUNTY  
HIGHWAY DEPT.

S.P. 0208-145 (T.H. 65)  
S.A.P. 002-716-013  
S.A.P. 197-020-004

NB T.H. 65 CROSS SECTIONS  
STA 679+00.00 TO  
Sheet 105 of 108 Sheets

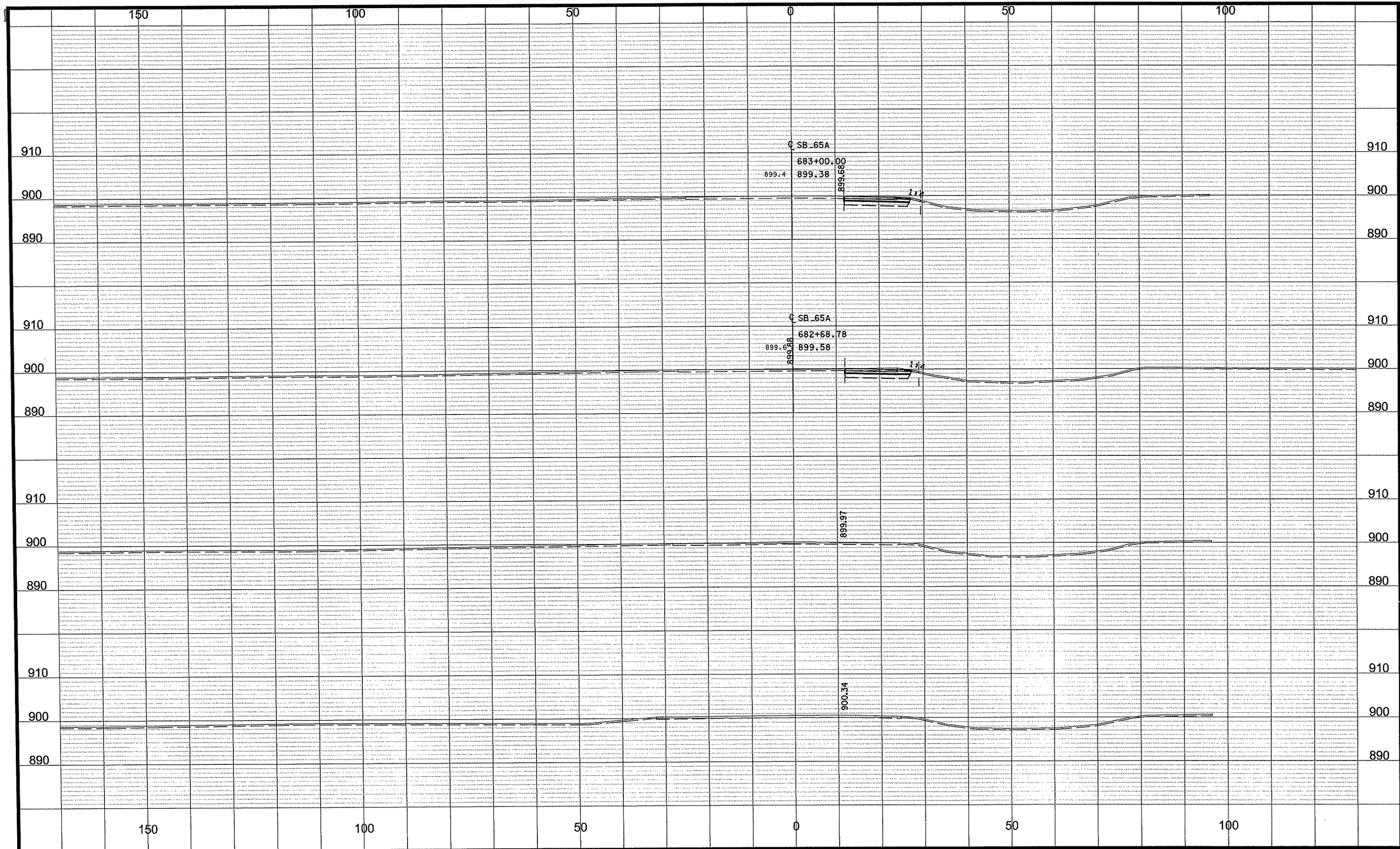

NO	DATE	BY	CKD	APPR	REVISION
NAME: p116-65plan116-65_XS_SB65.dgn					
					05/23/2012
					9:46:58 AM

DRAWN BY BAV DATE 3-23-12  
 DESIGN BY BAV DATE 3-23-12  
 CHECKED BY JEO DATE 4-10-12



**ANOKA COUNTY**  
**HIGHWAY DEPT.**

S.P. 0208-145 (T.H. 65)  
 S.A.P. 002-716-013  
 S.A.P. 197-020-004

**SB T.H. 65 CROSS SECTIONS**  
 STA 682+68.78 TO 683+00.00  
 Sheet 106 of 108 Sheets

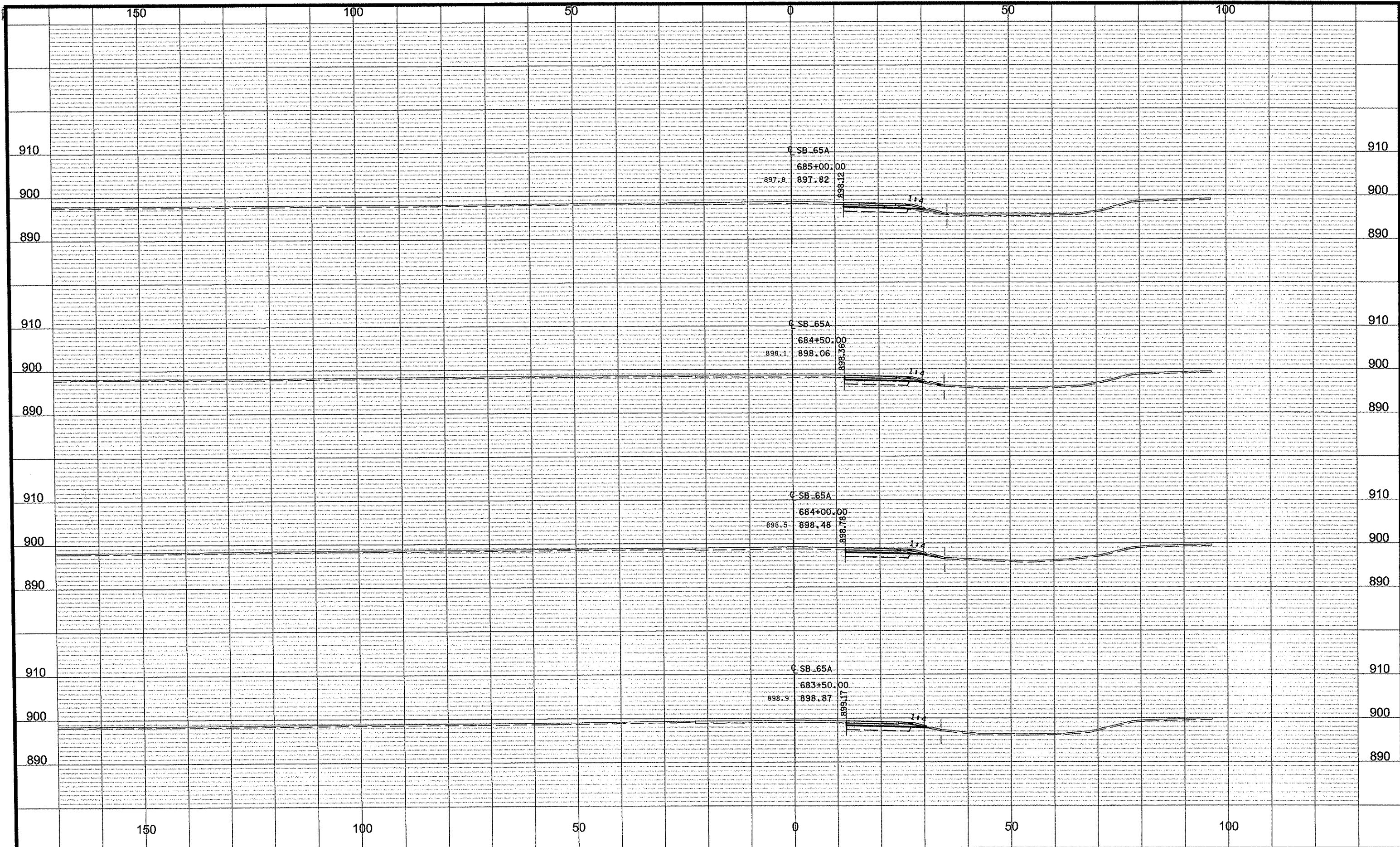

DRAWN BY BAV DATE 3-23-12  
 DESIGN BY BAV DATE 3-23-12  
 CHECKED BY JEO DATE 4-10-12



**ANOKA COUNTY**  
**HIGHWAY DEPT.**

S.P. 0208-145 (T.H. 65)  
 S.A.P. 002-716-013  
 S.A.P. 197-020-004

**SB T.H. 65 CROSS SECTIONS**  
 STA 683+50.00 TO 685+00.00  
 Sheet 107 of 108 Sheets

NO	DATE	BY	CKD	APPR	REVISION

NAME: p116-65\plan116-65\_XS\_SB65.dgn  
 05/23/2012 9:46:59 AM

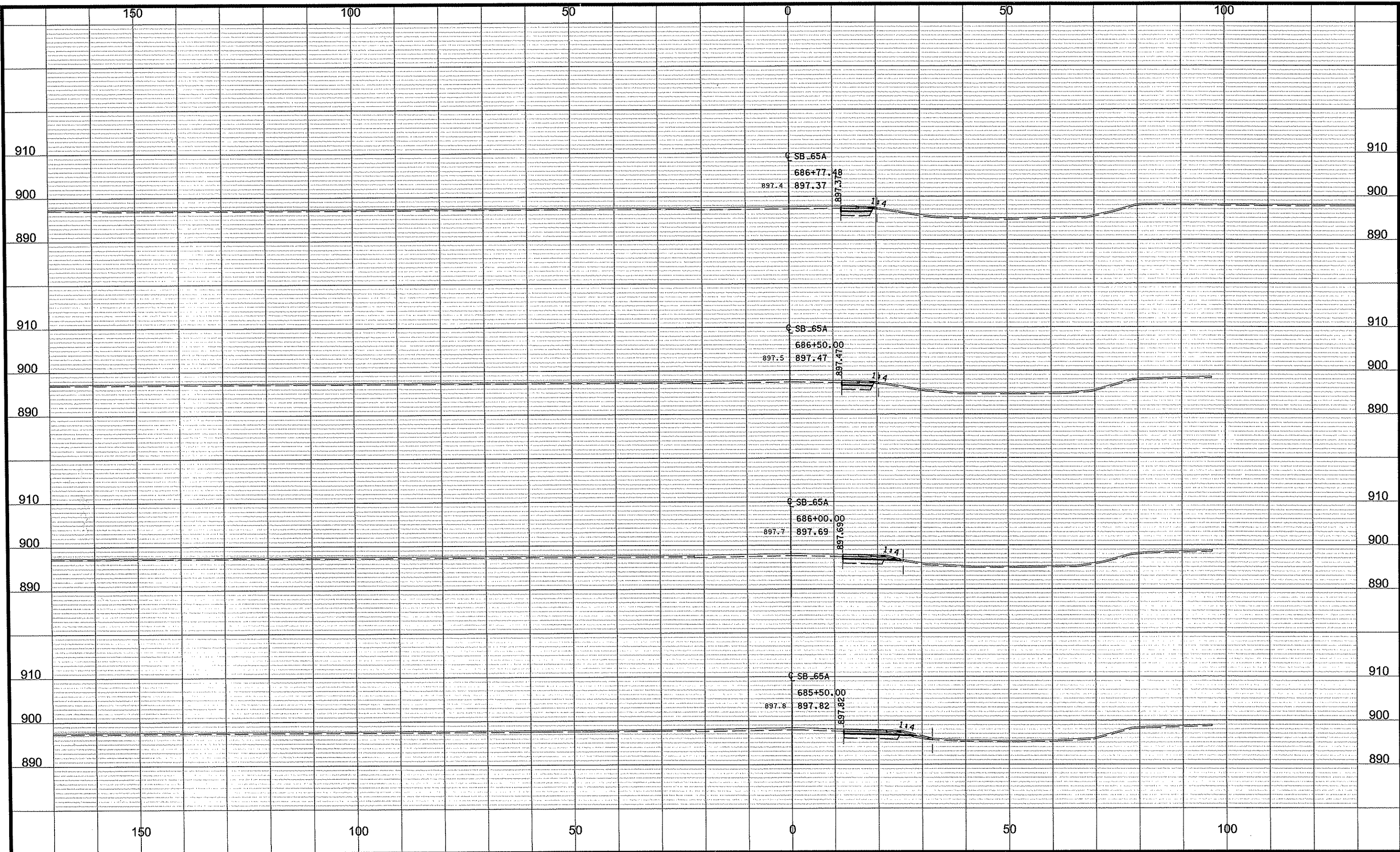

NO	DATE	BY	CKD	APPR	REVISION
NAME: p1116-69\plan116-65_XS_SB65.dgn					

DRAWN BY	BAV	DATE	3-23-12
DESIGN BY	BAV	DATE	3-23-12
CHECKED BY	JEO	DATE	4-10-12



**ANOKA COUNTY  
HIGHWAY DEPT.**

S.P. 0208-145 (T.H. 65)  
S.A.P. 002-716-013  
S.A.P. 197-020-004

**CROSS SECTIONS**  
STA 685+50.00 TO 686+77.48  
Sheet 108 of 108 Sheets