

MINN. PROJ. NO. \_\_\_\_\_  
 MINN. PROJ. NO. LOCAL FUNDS \_\_\_\_\_

# MINNESOTA DEPARTMENT OF TRANSPORTATION

## ANOKA COUNTY

### CONSTRUCTION PLAN FOR GRADING, AGGREGATE BASE AND BITUMINOUS SURFACING.

LOCATED ON CR 60 BETWEEN TH 65 AND EAST LAKE NETTA DRIVE (GEOGRAPHIC DESCRIPTION)

FROM A POINT 162.66' E. AND 1331.56' S. OF THE N.1/4 COR. OF SEC. 17, T-32 N. R-23 W. TO A POINT 1191.08' W. AND 1328.18' S. OF THE N.E. COR. OF SEC. 15, T-32 N. R-23 W. (LEGAL DESCRIPTION)

COUNTY PROJ. NO. 93-04-60

GROSS LENGTH 11,945 FEET 2.262 MILES  
 BRIDGES-LENGTH 0 FEET 0 MILES  
 EXCEPTIONS-LENGTH 0 FEET 0 MILES  
 NET LENGTH 11,945 FEET 2.262 MILES

GOVERNING SPECIFICATIONS  
 THE 1988 EDITION OF THE MINNESOTA DEPARTMENT OF TRANSPORTATION "STANDARD SPECIFICATIONS FOR CONSTRUCTION" AS AMENDED BY THE MAY 2, 1994 SUPPLEMENTAL SPECIFICATIONS SHALL GOVERN.

### INDEX

SHEET NO.	DESCRIPTION
1	TITLE SHEET
2	STATEMENT OF ESTIMATED QUANTITIES
3-5	TABULATION CHARTS
6	EARTHWORK SUMMARY
7	STANDARD DETAILS
8-9	EROSION CONTROL DETAILS
10-11	TYPICAL SECTIONS
12-16	EXISTING CONDITIONS AND REMOVAL PLAN
17-25	PLAN AND PROFILE
26-40	CROSS-SECTION
41-42	DETOUR PLAN

THIS PLAN CONTAINS 42 SHEETS

#### DESIGN DESIGNATION

$\leq$ N18<sub>20</sub> 901,764  
 R VALUE 70  
 ADT (1996)= 4550  
 Proj. ADT (2016)= 7735  
 Proj. HCADT (2016)= 580  
 Soil Factor N/A  
 10 TON DESIGN  
 Shoulder Width 8 FT.

Functional Classification  
 No. of Traffic Lanes 2 No. of Parking Lanes 0  
 Design Speed 55 MPH  
 Based on Stopping Sight Distance  
 Height of eye 3.5' Height of object 0.5  
 Design Speed not achieved at:  
 STA. TO STA. MPH  
 STA. TO STA. MPH  
 STA. TO STA. MPH

I HEREBY CERTIFY THAT THIS PLAN WAS PREPARED BY ME OR UNDER MY DIRECT SUPERVISION AND THAT I AM A DULY REGISTERED PROFESSIONAL ENGINEER UNDER THE LAWS OF THE STATE OF MINNESOTA.

DATE April 30 REG. NO. 20235 ENGR. [Signature] DESIGN ENGINEER

DESIGN SQUAD K. JOHNSON AND M. NAJI

Recommended for Approval \_\_\_\_\_ RIGHT-OF-WAY SECTION \_\_\_\_\_, 19 \_\_\_\_\_

Recommended for Approval \_\_\_\_\_ TRAFFIC SECTION \_\_\_\_\_, 19 \_\_\_\_\_

Recommended for Approval \_\_\_\_\_ CONSTRUCTION ENGINEER \_\_\_\_\_, 19 \_\_\_\_\_

Approved May 2, 1994 \_\_\_\_\_ ANOKA COUNTY ENGINEER

Approved \_\_\_\_\_, 19 \_\_\_\_\_ CITY OF HAM LAKE ENGINEER

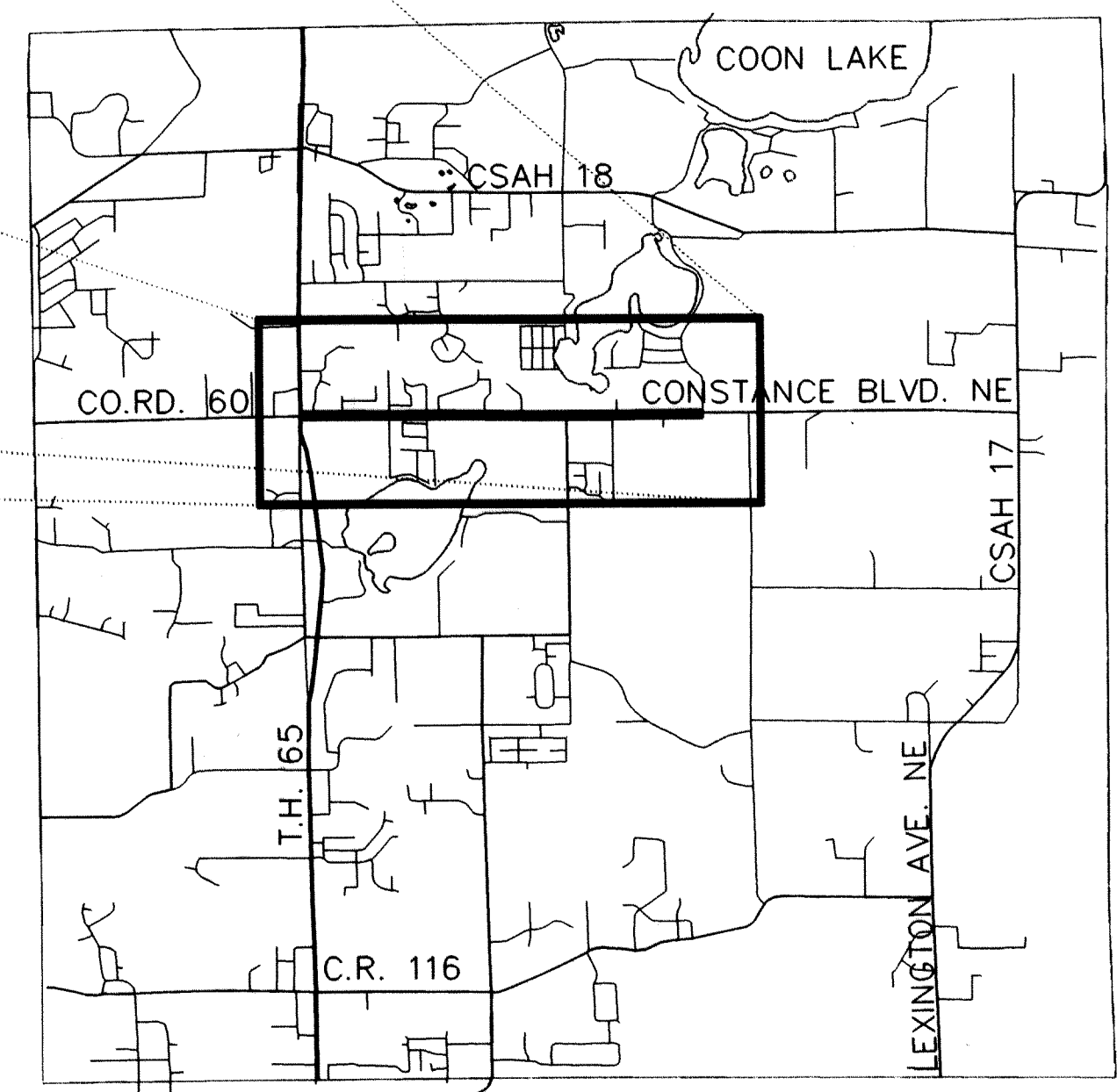
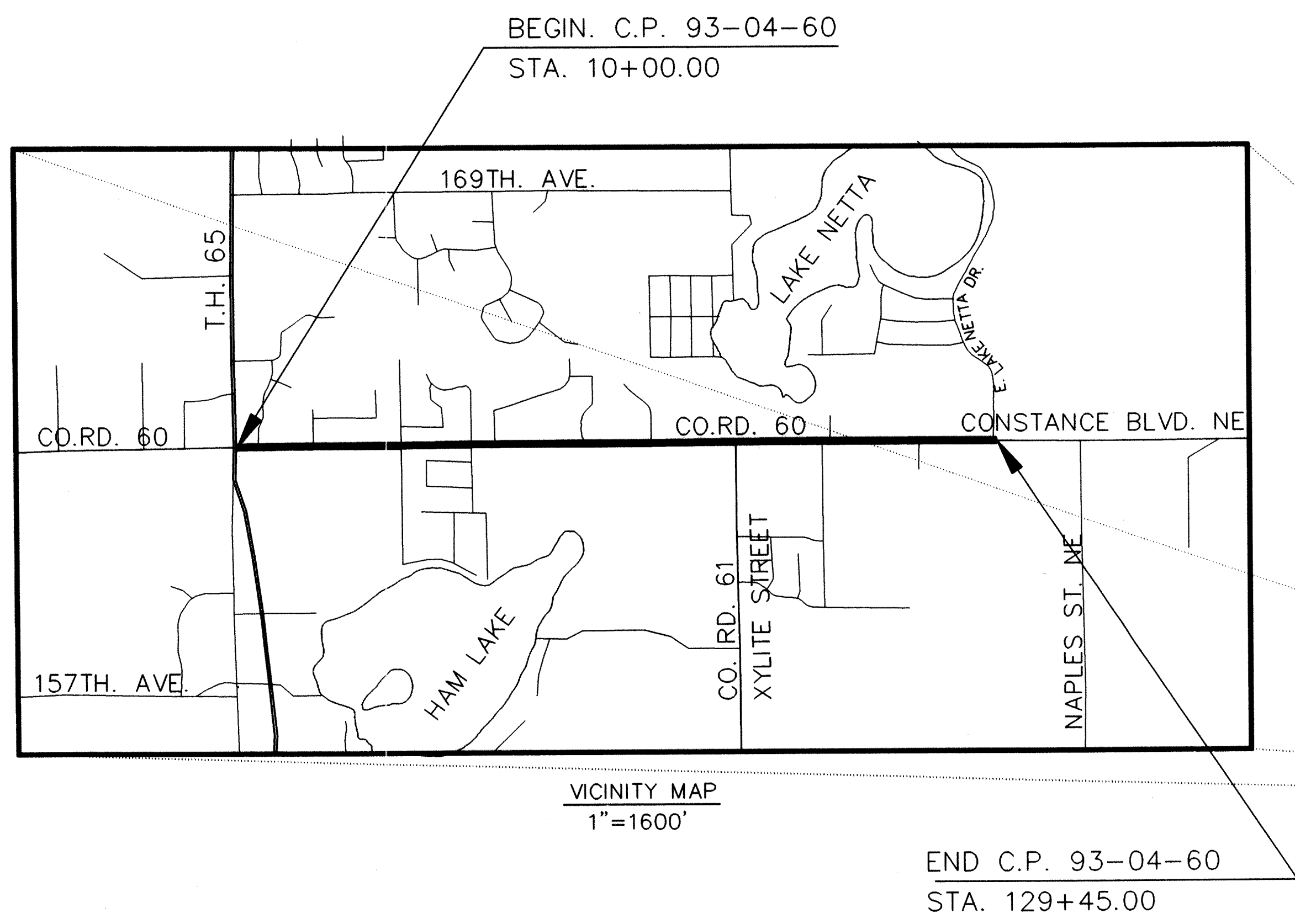

#### PLAN SYMBOLS

- COUNTY LINE
- TOWNSHIP OR RANGE LINE
- SECTION LINE
- QUARTER LINE
- SIXTEENTH LINE
- RIGHT OF WAY LINE
- SLOPE EASEMENT
- PRESENT RIGHT OF WAY
- PROPERTY LINE
- CORPORATE OR CITY LIMITS
- RETAINING WALL
- RAILROAD
- RAILROAD RIGHT OF WAY
- RIVER OR CREEK
- DRAINAGE DITCH
- CULVERT
- DROP INLET
- GAUDD RAIL
- BARBED WIRE FENCE
- WOVEN WIRE FENCE
- CHAIN LINK FENCE
- WOOD FENCE
- STONE WALL OR FENCE
- HEDGE
- LOWLAND
- TIMBER
- ORCHARD
- BRUSH
- NURSERY
- CATTLE GAUDD
- OVERPASS (Highway Over)
- UNDERPASS (Highway Under)
- BRIDGE
- BUILDING (One Story Frame)
- F-FRAME C-CONCRETE
- S-STONE T-TILE
- B-BRICK ST-STUCCO
- RAILROAD CROSSING BELL
- RAILROAD CROSSING GATE
- MANHOLE
- CATCH BASIN
- FIRE HYDRANT
- CAST IRON MONUMENT
- IRON PIN
- GRAVEL PIT
- SAND PIT
- BORROW PIT
- ROCK QUARRY
- GEOTECHNICAL BORINGS

#### UTILITY SYMBOLS

- POWER POLE LINE
- TELEPHONE OR TELEGRAPH POLE LINE
- JOINT TELEPHONE & POWER ON POWER POLES
- ON TELEPHONE POLES
- ANCHOR
- STEEL TOWER
- STREET LIGHT
- PEDESTAL (Cable Terminal)
- GAS MAIN
- WATERMAIN
- TELEPHONE CABLE IN CONDUIT
- ELECTRIC CABLE IN CONDUIT
- TELEPHONE MANHOLE
- ELECTRIC MANHOLE
- BURIED TELEPHONE CABLE
- BURIED ELECTRIC CABLE
- AERIAL TELEPHONE CABLE
- SEWER (Sanitary or Storm)
- SEWER MANHOLE

#### SCALES

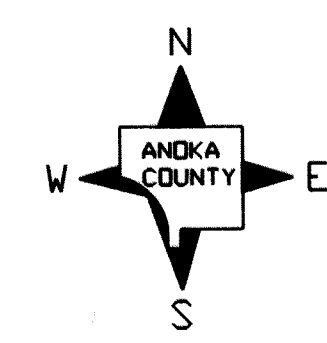
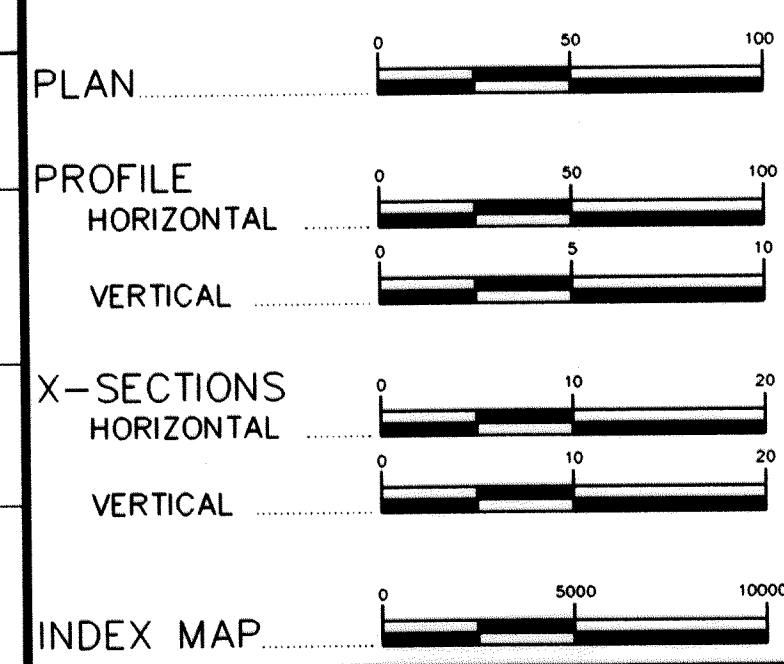

REVISIONS	DATE	BY

COUNTY PROJ. NO. 93-04-60  
 STATE PROJ. NO. \_\_\_\_\_ SHEET NO. 1 OF 42 SHEETS

FILE NAME: P:\930460\TITLE.DWG MN (04-30-96)

STATEMENT OF ESTIMATED QUANTITIES

CHART NO.	ITEM NO.	ITEM	UNIT	TOTAL QUANTITIES		ANOKA COUNTY	
				ESTIMATED	FINAL	C.P. 93-04-60 ESTIMATED	C.P. 93-04-60 FINAL
	0013.601	CELLULAR MOBILE TELEPHONE	LUMP SUM	1		1	
	0013.601	SURVEY EQUIPMENT	LUMP SUM	1		1	
	0015.601	COMPUTER EQUIPMENT	LUMP SUM	1		1	
	2021.501	MOBILIZATION	LUMP SUM	1		1	
	2031.501	FIELD OFFICE TYPE D	EACH	1		1	
	A 2101.501	CLEARING	ACRE	3.35		3.35	
	A 2101.502	CLEARING	TREE	331		331	
	A 2101.506	GRUBBING	ACRE	3.35		3.35	
	A 2101.507	GRUBBING	TREE	292		292	
①	H 2104.501	REMOVE FENCE	LIN FT	255		255	
①	R 2104.501	REMOVE CULVERT PIPE	LIN FT	450		450	
	C 2104.501	REMOVE CONCRETE RETAINING WALL	LIN FT	18		18	
②	D 2104.505	REMOVE BITUMINOUS PAVEMENT	SQ YD	31012		31012	
③	I 2104.505	REMOVE CONCRETE PAVEMENT	SQ YD	144		144	
	G 2104.509	REMOVE BITUMINOUS FLUME	EACH	4		4	
	K 2104.509	REMOVE DRAINAGE STRUCTURE	EACH	2		2	
	F 2104.511	SAVING CONCRETE PAVEMENT	LIN FT	38		38	
	E 2104.513	SAVING BITUMINOUS PAVEMENT	LIN FT	1275		1275	
①	H 2104.521	SALVAGE FENCE	LIN FT	3698		3698	
①	Q 2104.521	SALVAGE PIPE CULVERT	LIN FT	62		62	
	2104.523	SALVAGE SIGN TYPE C	EACH	35		35	
④	2104.523	SALVAGE SIGN TYPE SPECIAL	EACH	11		11	
	N 2105.501	COMMON EXCAVATION	CU YD	54135 (P)		54135 (P)	
	N 2105.505	MUCK EXCAVATION	CU YD	48952		48952	
	N 2105.507	SUBGRADE EXCAVATION	CU YD	583		583	
	N 2105.522	SELECT GRANULAR BORROW (LV)	CU YD	37634		37634	
⑤	2130.501	WATER	M-GAL	300		300	
⑦	D 2211.503	AGGREGATE BASE (CV) CLASS-5A	CU YD	10050 (P)		10050 (P)	
	2232.501	MILL BITUMINOUS SURFACE	SQ YD	480		480	
⑥	I 0331.601	2' THICK BIT WEARING COURSE	SQ YD	1172		1172	
	D 2340.508	TYPE 41 WEARING COURSE MIXTURE	TON	4817		4817	
⑩	D 2340.510	TYPE 31 BINDER COURSE MIXTURE	TON	5885		5885	
⑩	D 2340.514	TYPE 31 BASE COURSE MIXTURE	TON	4560		4560	
	D 2357.502	BITUMINOUS MATERIAL FOR TACK COAT	GAL	4699		4699	
	0412.602	MAIL BOX SUPPORT	EACH	32		32	
	2451.509	AGGREGATE BEDDING (LV)	CU YD	104		104	
	R 2501.511	15' CS PIPE CULVERT	LIN FT	475		475	
	R 2501.511	18' CS PIPE CULVERT	LIN FT	286		286	
	R 2501.511	24' RC PIPE CULVERT	LIN FT	180		180	
	R 2501.515	12' RC PIPE APRON	EACH	3		3	
	R 2501.515	15' RC PIPE APRON	EACH	2		2	
	R 2501.515	18' RC PIPE APRON	EACH	1		1	
	R 2501.515	21' RC PIPE APRON	EACH	1		1	
	R 2501.515	24' RC PIPE APRON	EACH	7		7	
	R 2501.567	15' CS SAFETY APRON AND GRATE DES 3128F	EACH	28		28	
	R 2501.569	18' CS SAFETY APRON AND GRATE DES 3128F	EACH	12		12	
	S 2503.541	12' RC PIPE SEWER DESIGN 3006	LIN FT	146		146	
	S 2503.541	15' RC PIPE SEWER DESIGN 3006	LIN FT	208		208	
	S 2503.541	18' RC PIPE SEWER DESIGN 3006	LIN FT	909		909	
	S 2503.541	21' RC PIPE SEWER DESIGN 3006	LIN FT	106		106	
	S 2503.541	24' RC PIPE SEWER DESIGN 3006	LIN FT	655		655	
	S 2506.501	CONSTRUCT DRAINAGE STRUCTURE DESIGN H	LIN FT	4.1		4.1	
	S 2506.501	CONSTRUCT DRAINAGE STRUCTURE DESIGN G	LIN FT	6.1		6.1	
	S 2506.501	CONSTRUCT DRAINAGE STRUCTURE DESIGN F	LIN FT	20.2		20.2	
	S 2506.516	CASTING ASSEMBLY	EACH	8		8	
	R-S 2511.507	GROUTED RIPRAP	CU YD	29		29	
⑪	2521.501	4' CONCRETE WALK	SQ FT	686		686	
⑪	M 2531.501	CONCRETE CURB AND GUTTER DESIGN B612	LIN FT	492		492	
	L 2535.501	BITUMINOUS CURB	LIN FT	2047		2047	
	H 0557.603	INSTALL FENCE	LIN FT	3698		3698	
	H 0557.603	TEMPORARY FENCING	LIN FT	2750		2750	
	0563.601	DETOUR SIGNING	LUMP SUM	1		1	
④	0564.602	INSTALL SIGN TYPE SPECIAL	EACH	11		11	
⑨	2573.501	BALE CHECK	EACH	1674		1674	
⑨	B 2573.503	SILT FENCE, PREASSEMBLED	LIN FT	3448		3448	
	J 2575.501	SEEDING	ACRE	14 (P)		14 (P)	
	J 2575.503	SEED, MIXTURE 600	POUND	1049		1049	
	J 2575.505	SODDING TYPE LAWN & BOULEVARD	SQ YD	17720		17720	
	J 2575.511	MULCH MATERIAL TYPE 1	TON	28		28	
	2575.519	DISK ANCHORING	ACRE	14 (P)		14 (P)	
	J 2575.523	WOOD FIBER BLANKET TYPE REGULAR	SQ YD	457		457	
	J 2575.531	COMM FERT ANALYSIS 10-10-10	POUND	6995		6995	
	2580.501	TEMPORARY LANE MARKING	RD STA	335		335	

CHART	SHEET NO.	DESCRIPTION
A	3	CLEARING AND GRUBBING
B	3	SILT FENCE
C	3	RETAINING WALL REMOVAL
D	4	BITUMINOUS REMOVAL
E	4	SAVING BITUMINOUS PAVEMENT
F	4	SAVING CONCRETE PAVEMENT
G	4	BIT. FLUME REMOVAL
H	4	FENCE CONSTRUCTION
I	4	ENTRANCES REMOVAL AND CONSTRUCTION CHART
J	4	TURF ESTABLISHMENT
K	4	DRAINAGE STRUCTURE REMOVAL
L	4	BITUMINOUS CURB CONSTRUCTION
M	4	CONCRETE CURB CONSTRUCTION
N	6	EARTHWORK SUMMARY
O	6	BASE AND BITUMINOUS QUANTITIES CHART
P	7	BERM CONSTRUCTION LOCATION
Q	10	RIGHT TURN LANE AND BYPASS LOCATION
R	5	CULVERT TABULATION
S	5	STORM SEWER TABULATION
T	5	DRAINAGE CASTING SCHEDULE
U	42	TRAFFIC CONTROL DEVICES

PLATE NO.	DESCRIPTION
3000 L	REINFORCED CONCRETE PIPE
3006 G	GASKET JOINT FOR R.C. PIPE
3014 J	REINFORCED CONCRETE PIPE ARCH
3100 G	CONCRETE APRON FOR REINFORCED CONCRETE PIPE
3110 G	CONCRETE APRON FOR REINFORCED CONCRETE PIPE-ARCH
3128 F	SAFETY APRON
3133 B	RIPRAP AT R.C.P. OUTLET
3145 E	CONCRETE PIPE TIES
4005 L	MANHOLE OR CATCH BASIN (DESIGN F)
4006 L	MANHOLE OR CATCH BASIN (DESIGN G AND DESIGN H)
4010 G	CONCRETE SHORT CONE & ADJUSTING RING
4020 G	MANHOLE OR CATCH BASIN COVER
4101 C	RING CASTING FOR MANHOLE OR CATCH BASIN
4110 E	COVER CASTING FOR MANHOLE
4126 F	CATCH BASIN FRAME CASTING
4140 D	SPECIAL GRATE CASTINGS FOR CATCH BASIN
4149 C	GRATE CASTING FOR CATCH BASIN
4161 F	CURB BOX CASTING FOR CATCH BASIN
4180 H	MANHOLE OR CATCH BASIN STEP
7065 C	BITUMINOUS CURB
7111 H	INSTALLATION & REINFORCEMENT OF CATCH BASIN CASTINGS
8000 I	STANDARD BARRICADES
9102 D	TURF ESTABLISHMENT AREAS (AT PIPE CULVERT ENDS)
9322 J	CHAIN LINK FENCE

2340	TYPE 41 PLANT MIXED WEARING COURSE AND BINDER COURSE BITUMINOUS MIXTURE 110 LBS./SQ.YD. PER 1' THICKNESS
2340	TYPE 31 PLANT MIXED BASE BITUMINOUS MIXTURE 110 LBS./SQ.YD. PER 1' THICKNESS
2357	BITUMINOUS MATERIAL FOR TACK 0.05 GALLONS PER SQ.YD. PER LIFT APPLIED
2575	MULCH MATERIAL TYPE 1,2 TONS PER ACRE
2575	COMMERCIAL FERTILIZER, ANALYSIS 10-10-10 500 LBS./ACRE ON ALL SEED AND SOD AREAS
2575	ROADSIDE SEEDING BASED ON HORIZONTAL MEASUREMENT +10% SEED MIXTURE NO. 600, 75LBS. PER ACRE

- NOTES
- ① INCLUDES ALL TYPES AND SIZES.
  - ② INCLUDES ALL BITUMINOUS PAVEMENTS IRREGARDLESS OF DEPTH AND WIDTH.
  - ③ INCLUDES ALL CONCRETE PAVEMENTS IRREGARDLESS OF DEPTH AND WIDTH.
  - ④ MUNICIPAL STREET SIGNS.
  - ⑤ FOR DUST CONTROL AS DIRECTED BY THE ENGINEER.
  - ⑥ FOR DRIVEWAY CONSTRUCTION SEE CHART I
  - ⑦ INCLUDES QUANTITY FOR AGGREGATE APPROACHES AND ENTERANCES.
  - ⑧ FOR USE AT CULVERT ENDS.
  - ⑨ FOR TEMPORARY EROSION CONTROL AS SHOWN IN THE PLANS AND AS DIRECTED BY THE ENGINEER.
  - ⑩ INCLUDES QUANTITY FOR ADDITIONAL 1/4' TO DESIGN PAVEMENT THICKNESS.
  - ⑪ FOR MEDIAN CONSTRUCTION.

STATEMENT OF ESTIMATED QUANTITIES

REVISIONS	DATE	BY

FILE NAME: \P\93046\TAB-CHDVG MN. (04-30-96)





CULVERT TABULATION										FURNISH & INSTALL CULVERT						RIPRAP OUTLETS				
STATION	LOC	INPLACE	REMARKS	SODDING CULV. PIPE		REMOVE CULV. PIPE		SALVAGE CULV. PIPE		INSTALL CULV. PIPE		15' CMP		18' CMP		24' RCP		CU. YD.		
				SQ. YD.	LIN. FT.	LIN. FT.	APR.	LIN. FT.	APR.	LIN. FT.	APR.	LIN. FT.	APR.	LIN. FT.	APR.	LIN. FT.	APR.			
21+68	44 RT	18" CMP	DAVENPORT ST.		72															
27+84	35 RT	15" CMP	EVELTH ST. N.		82									48	2					
30+29	40 RT	12" CMP	SCHOOL ENT.		46								46	2						
31+79	41 RT	12" CMP	SCHOOL ENT.		46															
35+20	35 RT		HASTINGS ST. NE.											50	2					
46+23	43 RT		KENYON ST. NE.											62	2					
48+27	41 RT		ENT. #16245										30	2						
64+08	39 LT.		QUAMBA ST. NE.											50	2					
67+41		15" CMP	ENT. #2259		30															
73+08	35 LT	15" CMP	ENT.		30								20	2						
75+05		18" CMP	TACONITE ST. NE.		64															
78+84	35 LT.	15" CMP	ENT. #2427		30								28	2						
80+19	35 RT.		NEW STREET					66	2					44	2					
80+20	35 LT.		ENT. #2441										34	2						
87+87	43 RT.		CD. RD. 61													62	2			
97+00	36 RT.		ENT. #2722										28	2						
102+28	36 LT.		ENT. #2807 (DBL ENT.)										54	2						
103+63	35 LT.		ENT. #2821										18	2						
104+46	39 RT.		ENT. #2824										44	2						
105+88	35 LT.		ENT.										26	2						
106+84	33 RT.		ENT. #2846										35	2						
110+33	33 RT.		ENT. #2914										22	2						
113+33	37 RT.		ENT. #2954										22	2						
114+84	37 RT.		ENT. #16250										20	2						
116+51	37 RT.		GUADALCANA												32	2				
125+03	LT. & RT.	18" CMP	X-ROAD		50											58	2		5.8	
TOTAL					450			66	2				475	28	286	12	180	6		11.6

① SAFETY APRON

DRAINAGE CASTING SCHEDULE				
ASS'Y TYPE	NO REQ'D	FRAME CASTING	GRATE CASTING	CURB BOX CASTING
A	3	801	810	821
B	4	700-7	720	
C	1	700-7	715	
TOTAL	8			

STORM SEWER TABULATION										FURNISH & INSTALL CULVERT						APRON	DRAINS TO	GRADE IN%	RIPRAP	
STRUCT.	STATION	LOC	REMARKS	MH/CB	DESIGN	PAY HT. LIN. FT.	TOP OF CASTING ELEVATION	OUTLET ELEVATION	CASTING ASSEMBLY	12" RCP LIN. FT.	15" RCP LIN. FT.	18" RCP LIN. FT.	21" RCP LIN. FT.	24" RCP LIN. FT.	EACH					
																			101	25+50
102	25+50	27.5 RT.	12" RC APRON OUTLET	OUTLET	APRON			905.00							1		DITCH	0.33	2.1	
103	29+30	20.9 LT.		CB.	H	2.2	908.76	906.41	A	42							104	0.56		
104	29+30	29.1 RT.	12" RC APRON OUTLET	OUTLET	APRON			906.14							1		DITCH	0.56	2.1	
105	32+65	28.6 LT.	12" RC APRON OUTLET	INLET	APRON			907.43		12					1		106	0.69		
106	32+65	20.9 LT.		CB.	G	2.6	910.10	907.32	A	50							107	0.32		
107	32+65	35.4 RT.	12" RC APRON OUTLET	OUTLET	APRON			907.14							1		DITCH	0.32	2.1	
201	45+87	38.4 LT.	15" RC APRON INLET	INLET	APRON			906.56			142				1		203	0.35		
202	47+35	40.0 RT.	12" RC APRON INLET	INLET	APRON			906.04			66				1		203	0.30		
203	47+35	33.0 LT.		MH.	G	3.5	909.30	905.63	B			429					204	0.40		
204	51+64	33.0 LT.		MH.	F	6.9	910.66	903.91	B			480					205	0.40		
205	56+50	47.0 LT.	18" RC APRON OUTLET	OUTLET	APRON			901.97							1		SWAMP	0.40	3.6	
301	101+62	41.0 RT.	18" RC APRON INLET	INLET	APRON			905.03				106			1		303	0.33		
302	100+50	29.8 LT.		INLET	APRON			905.62							1		303	1.65		
303	100+50	28.2 RT.		MH.	F	3.7	908.22	904.66	B								304	0.33		
304	97+85=0+32.7	32.7 RT.	ESMT. C/L STA. 0+32.7	MH.	F	5.4	909.02	903.79	B								305	0.40		
305	3+60	C/L	EASEMENT C/L	MH.	F	4.2	906.60	902.48	C								306	0.40		
306	3+76	C/L	EASEMENT C/L	OUTLET	APRON			902.42							1		SWAMP	0.40	3.6	
TOTAL						30.4			8	146	208	909	106	655	10					13.5

TABULATION CHARTS

CULVERT TABULATION  
STORM SEWER TABULATION  
DRAINAGE CASTING SCHEDULE

REVISIONS	DATE	BY

FILE NAME: P:\930460\TAB-CH.DWG MN. (4-30-96)

EARTHWORK SUMMARY (N)

Fed. Project No. \_\_\_\_\_

EXCAVATION

COMMON EXCAVATION . . . 58,833 CU.YD. { REGULAR . . . 36,838 CU.YD. (1)  
 SUBCUT . . . 11,833 CU.YD.  
 TOPSOIL . . . 10,162 CU.YD.  
 MUCK EXCAVATION . . . . 48,952 CU.YD.  
 SUBGRADE EXCAVATION . . . . 583 CU.YD.

EMBANKMENT (CV)

SELECT GRANULAR . . . . 57,498 CU.YD.  
 SUBCUT . . . . . 11,833 CU.YD.  
 TOPSOIL . . . . . 7,257 CU.YD.  
 MUCK . . . . . 3,408 CU.YD.

BALANCE

TOPSOIL  
 TOPSOIL DRESSING (CV) - [TOPSOIL STRIPPING (EV) x SHRINKAGE FACTOR] = EXCESS(-) OR SHORTAGE(+)  
 7,257 - (10,162 x 0.85) = -1,380 CU.YD. EXCESS  
 SELECT GRANULAR BORROW  
 SEL.SGRAN(CV)+SUBCUT - [REGULAR EXCAVATION (EV) x SHRINKAGE FACTOR] - [SUBCUT EXCAVATION x SHRINKAGE FACTOR] = EXCESS(-) OR SHORTAGE(+)  
 57,498+11,833 - [(36,838 - 4,698) x 0.85] - (11,833 x 0.90) = 31,362 CU.YD. BORROW  
 BORROW = (CV) x SWELL FACTOR = 31,362 x 1.2 = 37,634 CU.YD. (LV)  
 MUCK  
 MUCK EMBANKMENT (CV) - [MUCK EXCAVATION (EV) x SHRINKAGE FACTOR] = EXCESS(-) OR SHORTAGE(+)  
 3,408 - (48,952 x 0.85) = -38,201 CU.YD. EXCESS

SOIL FACTORS:

- (1) REGULAR GRADING AND TOPSOIL DRESSING (EV TO CV): 85% SHRINKAGE
- (2) SUBCUT COMPACTION (EV TO CV): 90% SHRINKAGE
- (3) SELECT GRANULAR BORROW (CV TO LV): 120% SWELL
- (4) MUCK EXCAVATION (EV TO CV): 60% SHRINKAGE

(1) INCLUDES 4,698 CU.YD. CONCRETE AND BITUMINOUS REMOVAL. CONCRETE AND BITUMINOUS PAVEMENT REMOVALS WILL BE PAID UNDER ITEM 2104.

SOILS AND CONSTRUCTION NOTES:

1. TOP OF GRADING GRADE IS DEFINED AS THE BOTTOM OF THE AGGREGATE BASE.
2. IN FILL AREAS, THE SUBGRADE SHALL BE CONSTRUCTED WITH SELECTED GRADING MATERIAL.
3. SELECTED GRADING MATERIALS SHALL CONSIST OF SELECT GRANULAR MATERIALS.
4. GRANULAR MATERIAL, REGARDLESS OF SOURCE, SHALL MEET THE REQUIREMENTS OF SPEC. 3149.2B.
5. COMPACTION OF THE GRADING PORTION OF THIS PROJECT SHALL BE BY THE "QUALITY COMPACTION METHOD" WITH THE EXCEPTION OF CULVERT AND STORM SEWER TRENCHES WHICH SHALL BE COMPACTED BY THE "SPECIFIED DENSITY METHOD".
6. TEST ROLLING WILL NOT BE REQUIRED.
7. BITUMINOUS OR CONCRETE ITEMS REMOVED BY CONSTRUCTION SHALL BECOME THE PROPERTY OF THE CONTRACTOR AND SHALL BE EITHER RECYCLED OR DISPOSED OF IN ACCORDANCE WITH THE REQUIREMENTS OF 2104.3C3 WITH NO DIRECT COMPENSATION MADE THEREFORE.
8. DISPOSITION OF EXCESS EXCAVATED MATERIAL SHALL BE IN ACCORDANCE WITH THE REQUIREMENTS OF 2105.3D WITH NO DIRECT COMPENSATION THEREFORE.
9. WHERE MATCHING INTO THE INPLACE ROADWAY AT THE ENDS OF CONSTRUCTION, CUT VERTICALLY TO THE TOP OF THE GRADING GRADE, AND THEN AT A 20:1 TAPER TO THE BOTTOM OF THE RECOMMENDED SUBGRADE EXCAVATION.
10. WHERE CONNECTING NEW SURFACING TO AN INPLACE PAVEMENT, THE EXCAVATION SHALL BE BACKFILLED PROMPTLY TO AVOID UNDERMINING THE INPLACE PAVEMENT.
11. USE TACK COAT BETWEEN ALL BITUMINOUS MIXTURES PRIOR TO PLACING BITUMINOUS MIXTURES AND PRIOR TO PLACING ANY BITUMINOUS MIXTURES ON EXISTING CONCRETE OR BITUMINOUS SURFACES. THE BITUMINOUS TACK COAT MATERIAL SHALL BE APPLIED AT UNIFORM RATE OF 0.03 TO 0.05 GALLONS PER SQUARE YARD BETWEEN BITUMINOUS LAYERS. THE APPLICATION RATES ARE FOR UNDILUTED EMULSION (AS SUPPLIED FROM THE REFINERY); ASPHALT EMULSION MAY BE FURTHER DILUTED IN THE FIELD IN ACCORDANCE WITH SPEC. 2357.
12. COMPACTION OF ALL OF THE BITUMINOUS COURSES SHALL BE BY THE "MODIFIED SPECIFIED DENSITY METHOD".
13. COMPACTION OF THE AGGREGATE BASE LAYERS SHALL BE BY THE "SPECIFIED DENSITY METHOD".
14. PLACE MINIMUM 4 INCHES TOPSOIL OR SLOPE DRESSING ON ALL AREAS DISTURBED BY CONSTRUCTION AND SCHEDULED FOR PERMANENT TURF ESTABLISHMENT. FERTILIZE WITH COMMERCIAL FERTILIZER, ANALYSIS 10-10-10, AT A RATE OF 500 POUND PER ACRE.
15. USE MIXTURE 600 SEED AND TYPE 1 MULCH IN AREAS TO BE SEEDED.
16. SOD ALL DISTURBED LAWNS.
17. ALL SOD UTILIZED WITHIN THE PROJECT LIMITS SHALL MEET THE REQUIREMENTS OF SPEC. 3878.2A (LAWN AND BOULEVARD SOD).
18. ORGANIC AND NONGRANULAR EXCAVATED MATERIAL MAY BE USED IN EMBANKMENT CONSTRUCTION IN AREAS OUTSIDE OF A 1 1/2:1 SLOPE FROM THE BACK OF CURB, OR GRADING P.I.
19. BITUMINOUS REMOVAL QUANTITY BASED ON SQUARE YARDS REMOVED. IN PLACE SURFACE ASSUMED TO BE 5-1/2 INCH IN DEPTH. CONTRACTOR SHALL INVESTIGATE AND MAKE OWN DETERMINATION OF ACTUAL PAVEMENT DEPTH.
20. ALL SILT FENCING AS SHOWN IN THE PLANS SHALL BE IN PLACE PRIOR TO THE COMMENCEMENT OF GRADING OPERATIONS.
21. A DOUBLE ROW OF BALE CHECKS SHALL BE INSTALLED TO PROTECT THE DNR PROTECTED WATERS AND WETLAND "F", BOTH NORTH AND SOUTH OF THE ROAD.
22. PERMANENT DITCH CHECKS TO SERVE AS SEDIMENTATION BASINS SHALL BE CONSTRUCTED IN DITCH INLETS INTO THE DNR PROTECTED WATERS AND WETLANDS "F" AT LOCATIONS TO BE DETERMINED BY THE ENGINEER. THIS WORK SHALL BE CONSIDERED INCIDENTAL WITH NO DIRECT PAYMENT MADE THEREFORE.
23. PARCELS 1, 2, 4, 9 AND 10 HAVE SEPTIC SYSTEMS AND DRAIN FIELDS WHICH WILL BE WITHIN THE NEW RIGHT-OF-WAY. CARE SHALL BE EXERCISED WHEN WORKING ON OR NEAR THESE SYSTEMS. SPECIFIC CONDITIONS ARE AS FOLLOWS:
  - A. ONLY EQUIPMENT WITH TRACKS SHOULD BE USED IN THE VICINITY OF DRAIN FIELDS SO AS NOT TO COMPACT SOILS.
  - B. TREES SCHEDULED FOR CLEARING AND GRUBBING IN OR AROUND A SEPTIC SYSTEM SHALL BE CUT AND STUMPS GROUND DOWN. TOTAL STUMP AND ROOT REMOVAL COULD AFFECT DRAIN FIELD OPERATIONS.
  - C. NO EQUIPMENT OF ANY KIND SHALL BE ALLOWED 27' NORTH OF CENTERLINE ALONG PARCEL 2.

BASE AND BITUMINOUS QUANTITIES CHART (D)

STATION - STATION	LOCATION	DESCRIPTION	BIT. SURFACE CONSTRUCTION		BIT. WEAR		BIT. BINDER		BIT. BASE		BITUMINOUS TACK COAT		AGGREGATE BASE CL-5A	
			SQ. YD.	DEPTH	TON	DEPTH	TON (1)	DEPTH	TON (1)	GALLON	DEPTH	CU. YD.		
10+00 - 16+40	RT	MAINLINE	1930	1.5'	159	1.5'	186	2'	239	193	5'	306		
11+90 - 12+84	LT	SHOULDER WIDENING	49	1.5'	4	1.5'	5			2	6'	13		
21+15 - 129+45	12' LT & RT	MAIN LINE	28880	1.5'	2383	1.5'	2896	2'	3872	2948	5'	4011		
21+15 - 21+85	20' LT	SHOULDER	62	1.5'	5	1.5'	6			3	5'	12		
21+15 - 37+10	20' RT	SHOULDER	1418	1.5'	117	1.5'	145			71	5'	285		
21+15 - 86+13	20' LT	SHOULDER	5776	1.5'	477	1.5'	591			289	5'	1160		
21+85 - 28+90	20' LT	BERM SHOULDER	627	1.5'	59	1.5'	73			36	5'	124		
28+90 - 30+44	20' LT	SHOULDER	137	1.5'	11	1.5'	14			7	5'	27		
30+44 - 35+06	24' RT	RIGHT TURN LANE	616	1.5'	51	1.5'	62	2'	83	64	5'	105		
35+06 - 37+10	20' RT	SHOULDER	181	1.5'	15	1.5'	19			9	5'	36		
37+10 - 39+00	20' RT	BERM SHOULDER	178	1.5'	17	1.5'	21			10	5'	35		
39+00 - 52+59	20' RT	SHOULDER	1208	1.5'	100	1.5'	124			60	5'	243		
50+23 - 56+55	20' LT	SHOULDER	562	1.5'	46	1.5'	57			28	5'	113		
52+59 - 57+00	20' RT	BERM SHOULDER	392	1.5'	37	1.5'	46			23	5'	78		
56+55 - 66+50	20' LT	SHOULDER	884	1.5'	73	1.5'	90			44	5'	178		
57+00 - 74+59	20' RT	SHOULDER	1564	1.5'	129	1.5'	160			78	5'	314		
65+50 - 67+36	20' LT	BERM SHOULDER	76	1.5'	8	1.5'	9			4	5'	15		
67+36 - 75+18	20' LT	SHOULDER	695	1.5'	57	1.5'	71			35	5'	140		
74+59 - 77+29	20' RT	BERM SHOULDER	240	1.5'	23	1.5'	28			14	5'	48		
75+18 - 76+49	20' LT	BERM SHOULDER	116	1.5'	11	1.5'	14			7	5'	23		
76+49 - 84+23	20' LT	SHOULDER	688	1.5'	57	1.5'	70			34	5'	138		
77+29 - 82+93	20' RT	SHOULDER	501	1.5'	41	1.5'	51			25	5'	101		
82+93 - 88+51	24' RT	RIGHT TURN LANE	744	1.5'	61	1.5'	75	2'	100	78	5'	127		
84+23 - 91+93	24' LT	BYPASS LANE	1027	1.5'	85	1.5'	103	2'	138	107	5'	175		
88+51 - 90+50	20' RT	SHOULDER	177	1.5'	15	1.5'	18			9	5'	36		
91+93 - 93+75	20' LT	BERM SHOULDER	162	1.5'	17	1.5'	19			9	5'	32		
90+50 - 91+90	20' RT	BERM SHOULDER	124	1.5'	12	1.5'	15			7	5'	25		
91+90 - 123+98	20' RT	SHOULDER	2852	1.5'	235	1.5'	292			143	5'	573		
93+75 - 129+45	20' LT	SHOULDER	3173	1.5'	262	1.5'	325			159	5'	637		
123+98 - 129+45	20' RT	BYPASS LANE	729	1.5'	60	1.5'	73	2'	98	76	5'	124		
21+67	50' RT	DAVENPORT ST.	139	1.5'	11	1.5'	14			7	5'	49		
21+70	50' LT	DAVENPORT ST.	139	1.5'	11	1.5'	14			7	5'	49		
27+83	50' RT	EVELETH ST.	129	1.5'	11	1.5'	13			7	5'	46		
35+20	50' RT	HASTINGS ST.	112	1.5'	9	1.5'	11			6	5'	40		
35+38	50' LT	HASTINGS ST.	132	1.5'	11	1.5'	13			7	5'	47		
46+23	50' LT	KENYON ST.	122	1.5'	10	1.5'	12			6	5'	44		
46+25	50' RT	KENYON ST.	115	1.5'	10	1.5'	12			6	5'	41		
50+11	50' LT	STREET APPROACH	116	1.5'	10	1.5'	12			6	5'	42		
64+08	50' LT	QUAMBA ST.	132	1.5'	11	1.5'	13			7	5'	47		
75+05	50' LT	TACONITE ST.	139	1.5'	11	1.5'	14			7	5'	49		
80+19	50' RT	NEW STREET	143	1.5'	12	1.5'	14			7	5'	51		
87+87	74' RT	COUNTY ROAD 61	275	1.5'	23	1.5'	27	2'	31	28	5'	94		
101+31	50' RT	BATAAN ST.	119	1.5'	10	1.5'	12			6	5'	43		
116+51	50' RT	GUADALCANA ST.	122	1.5'	10	1.5'	12			6	5'	44		
128+16	72' LT	E. LAKE NETTA DR.	255	1.5'	21	1.5'	25			13	5'	88		
21+15 - 129+45	20' LT & RT	1.5' ENT. KICKOUT	120	1.5'	10	1.5'	12				5'	43		
			58075		4817		5885		4560		4699		10050	

(1) INCLUDES AN ADDITIONAL 1/4" THICKNESS TO THE PLANNED QUANTITY.

TABULATION CHARTS, EARTHWORK SUMMARY, CONSTRUCTION NOTES

FILE NAME: P:\930460\TAB-CH.DWG MN. 04-30-96

REVISIONS	BY	DATE

TYPICAL UNPAVED ENTRANCE

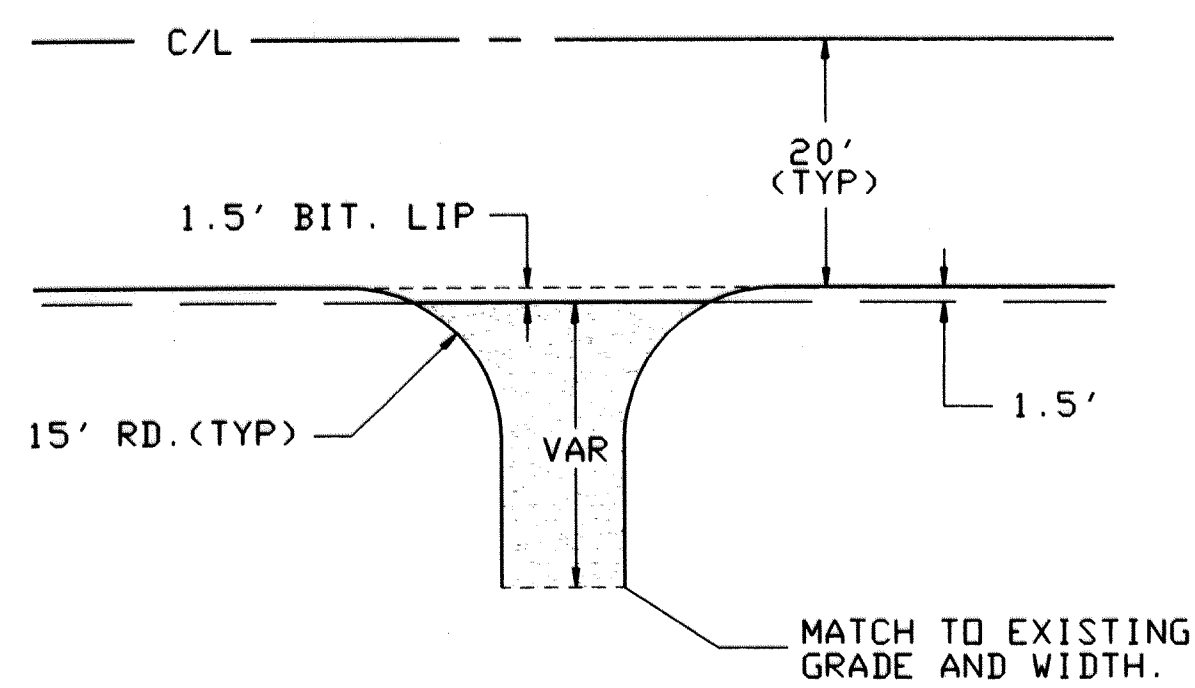

NOTE: ENTRANCE INSLOPE SHALL BE 6:1.

BITUMINOUS APRON DETAIL

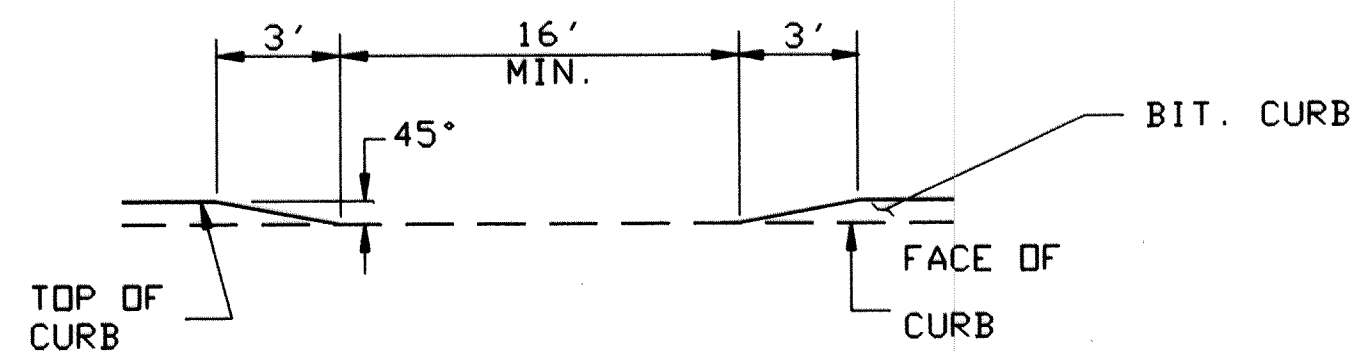
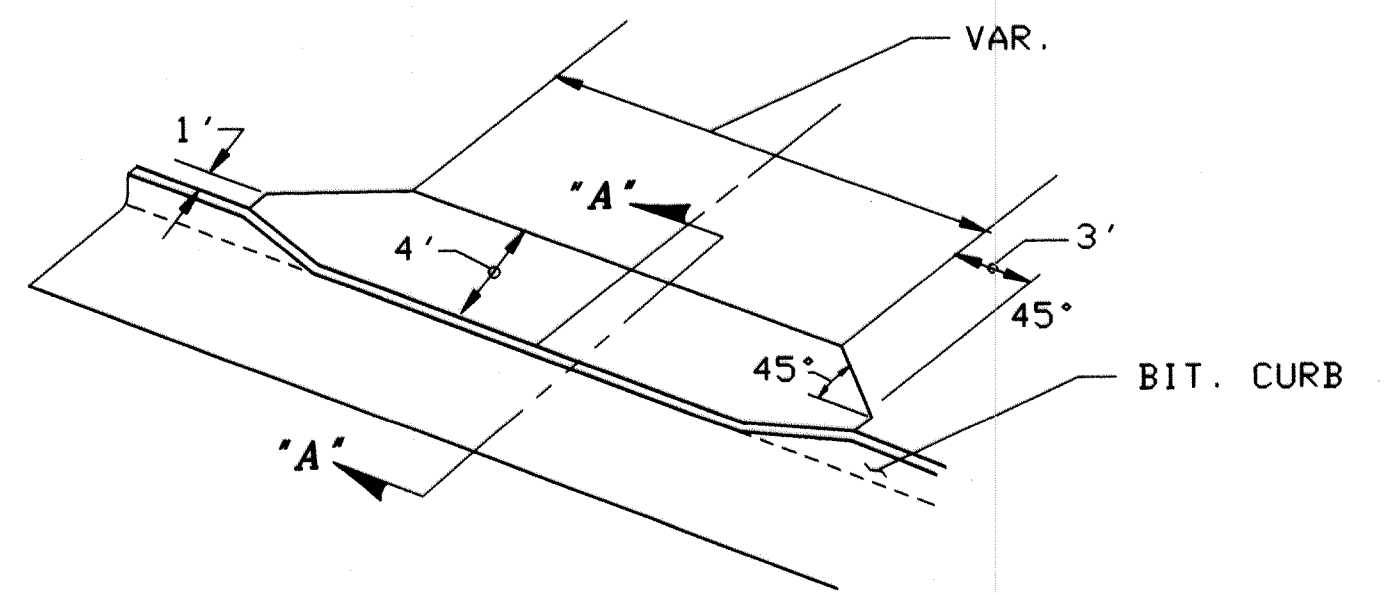

SECTION 'A'-'A'

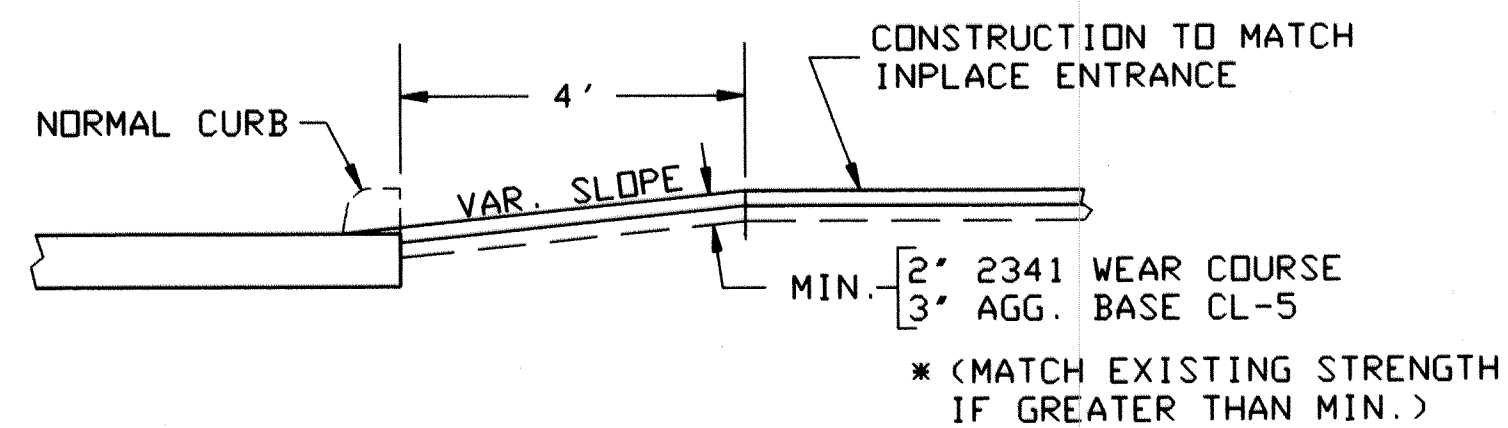

GRADING BERM

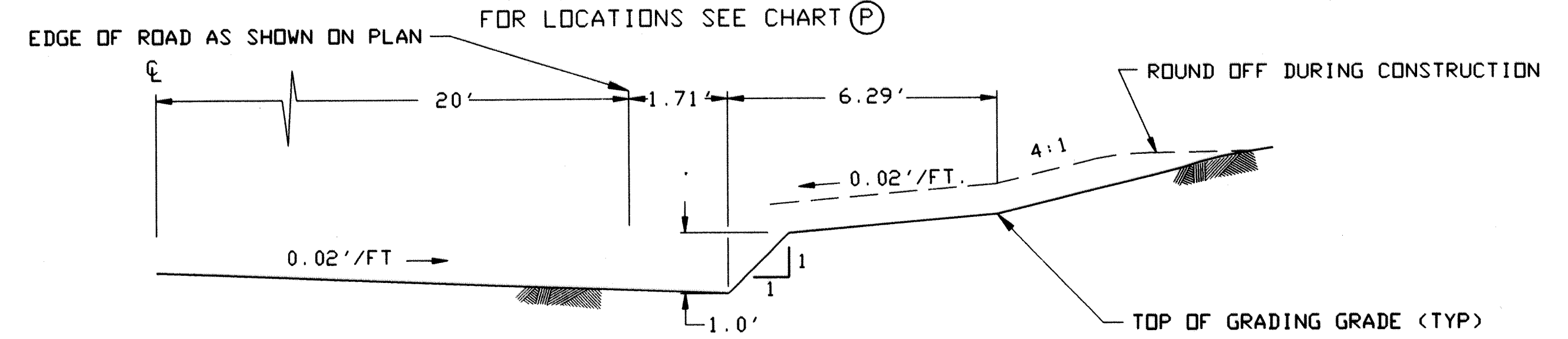

BITUMINOUS CURB DETAIL

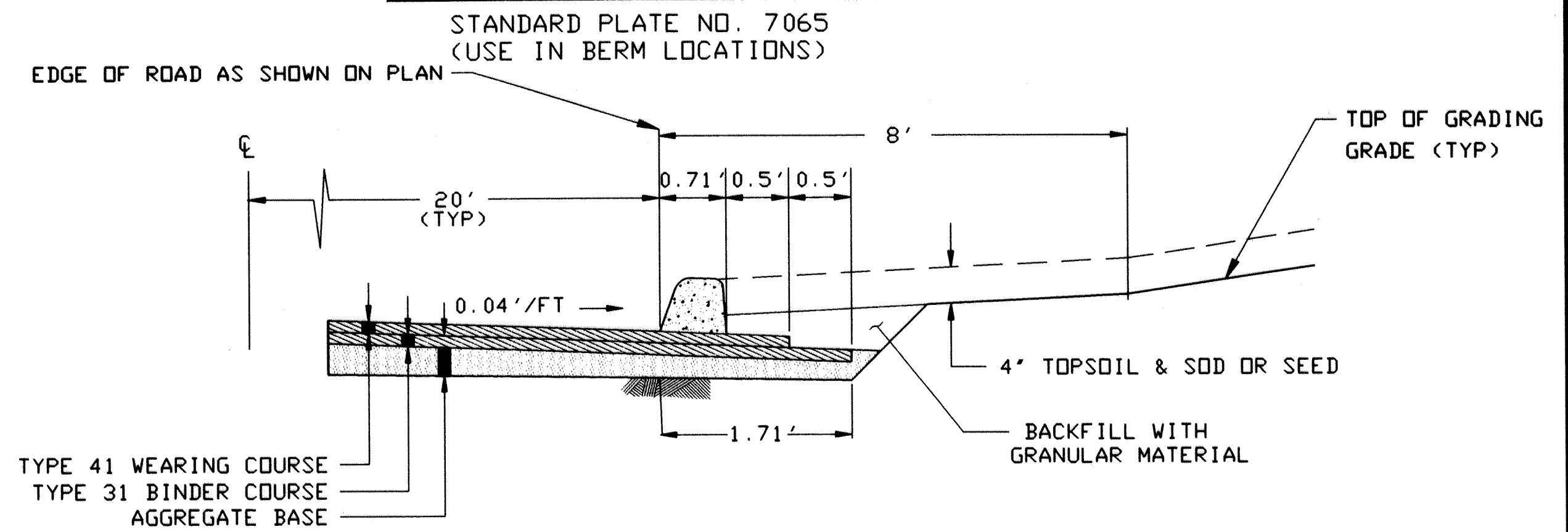

MILLING DETAILS

BUTT JOINTS (PLAN VIEW)

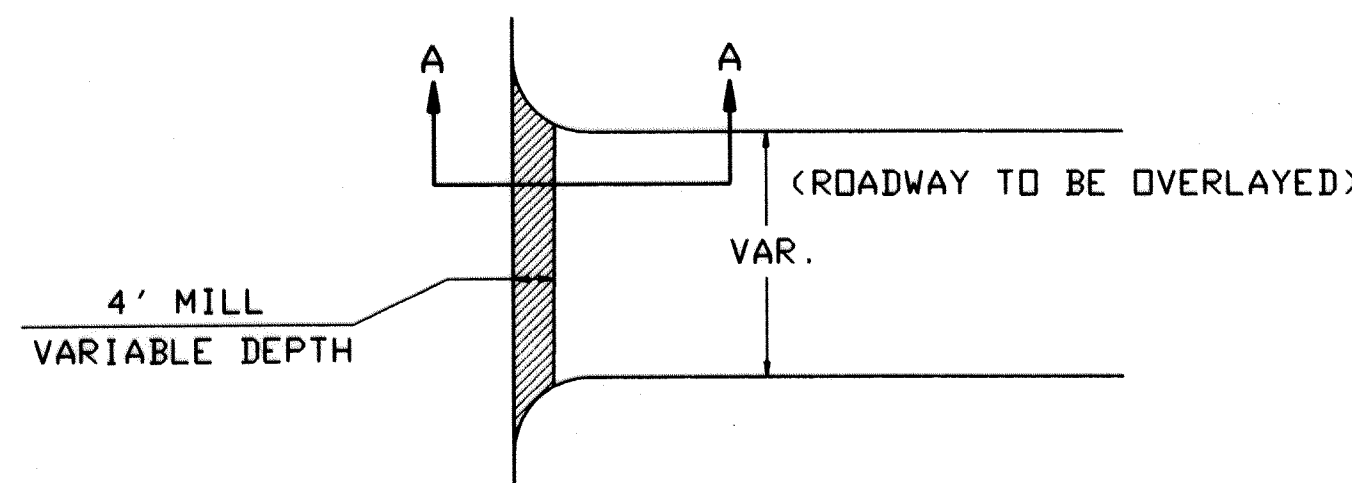

SECTION A-A

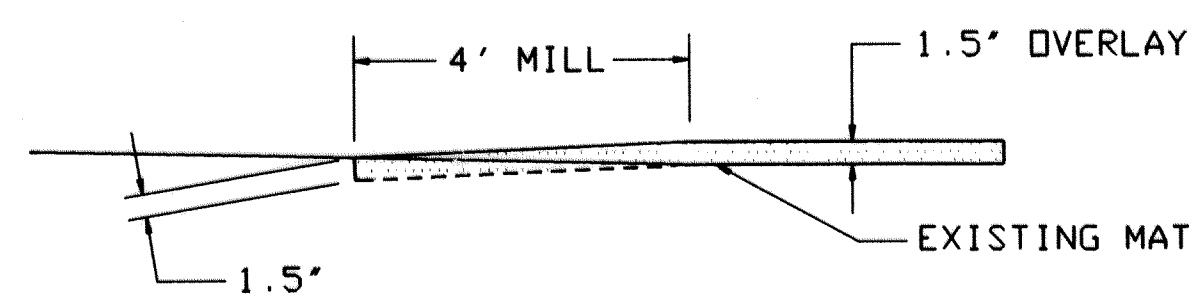

BITUMINOUS SIDE STREETS

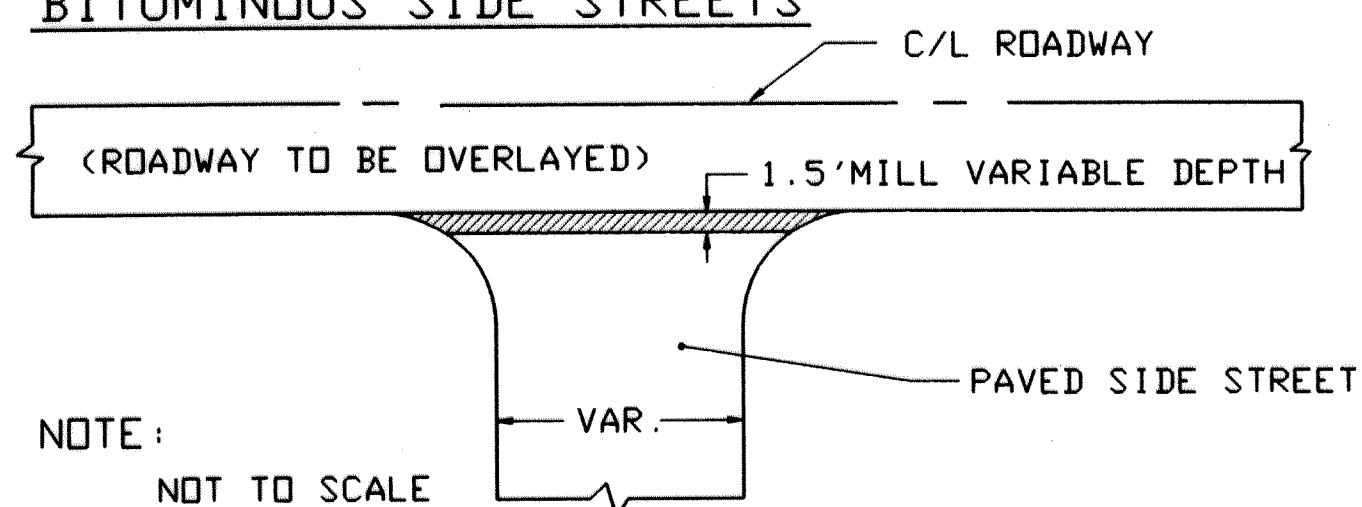

NOTE: NOT TO SCALE

BERM CONSTRUCTION LOCATION (P)			
STATION - STATION	LOCATION	LIN. FT.	REMARKS
21+85 - 22+76	20' LT	91	
22+86 - 23+70	20' LT	84	
23+88 - 24+80	20' LT	92	
24+92 - 25+66	20' LT	74	
25+77 - 26+45	20' LT	68	
26+64 - 27+53	20' LT	89	
27+71 - 28+90	20' LT	119	
29+06 - 29+70	20' LT	64	
29+94 - 31+25	20' LT	131	
31+51 - 32+07	20' LT	56	
32+29 - 35+27	20' LT	298	
37+10 - 39+00	20' RT	190	
65+50 - 67+58	20' LT	208	
71+02 - 74+38	20' RT	336	
74+66 - 77+52	20' RT	286	
75+18 - 76+72	20' LT	154	
90+20 - 91+78	24' LT	158	
91+99 - 93+30	20' LT	131	
TOTAL		2629	

FILE NAME: P:\930460\TAB-CHDVG MN. (04-30-96)

REVISIONS	BY	DATE

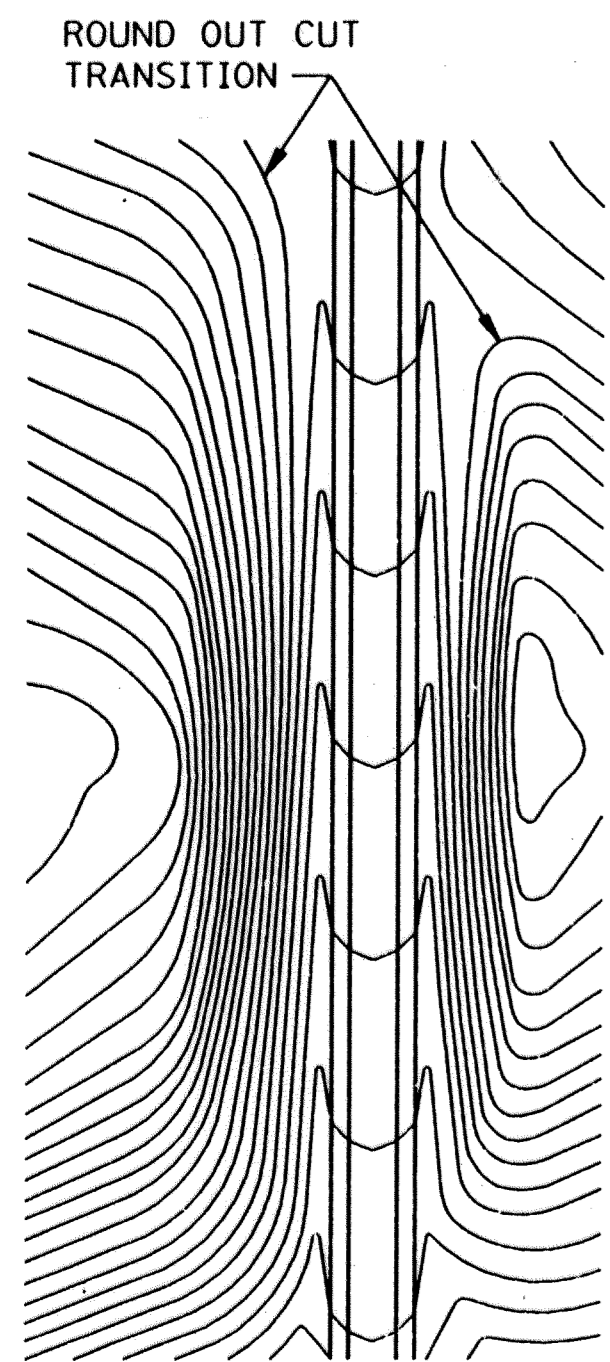

CONTOURING ROAD CUTS

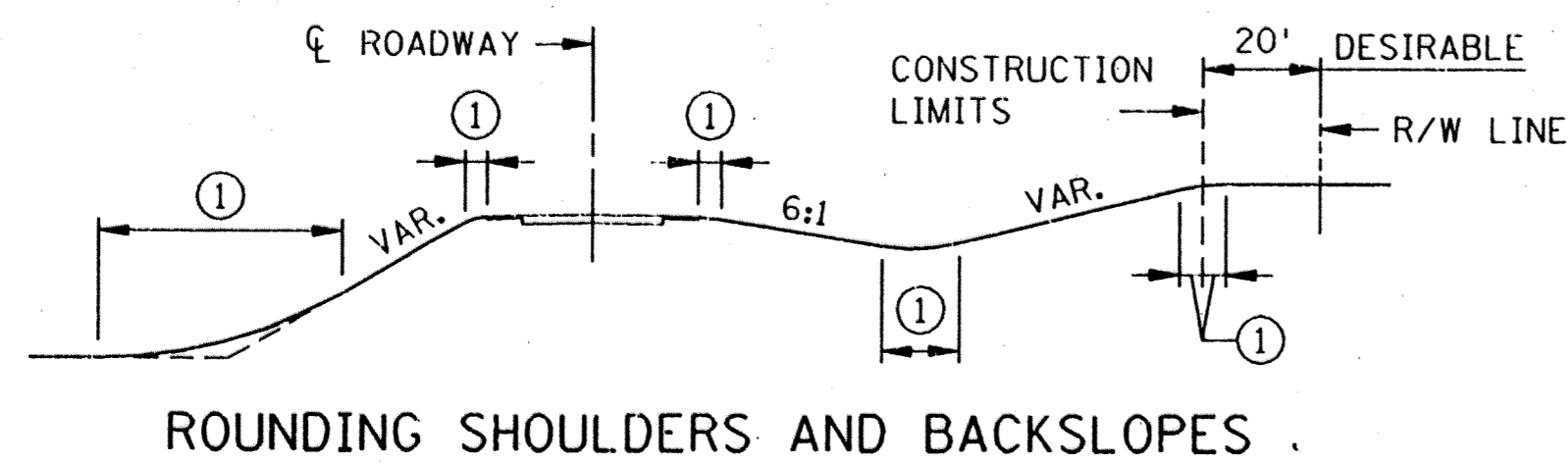

ROUNDING SHOULDERS AND BACKSLOPES

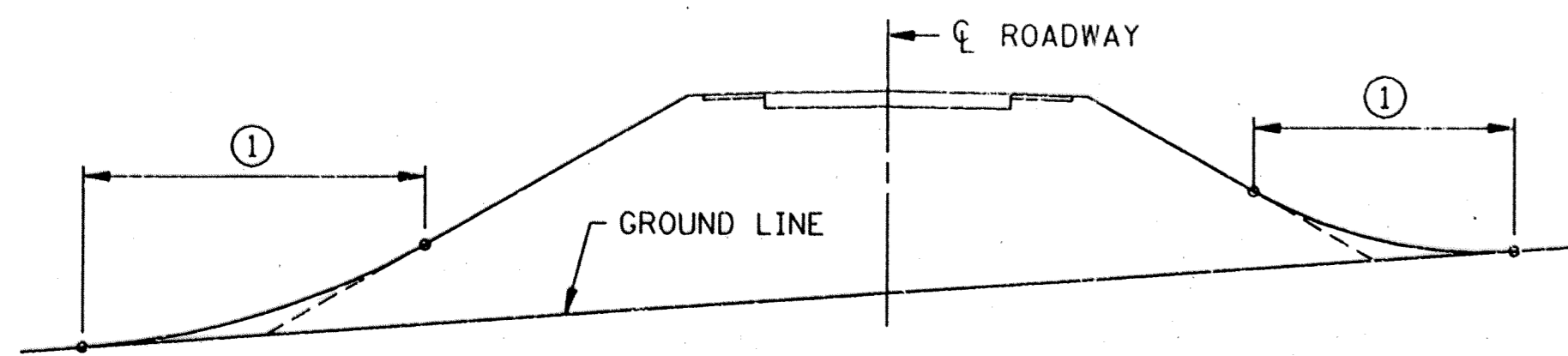

SHAPING FOR DRAINAGE ALONG THE TOE OF FILL SLOPES

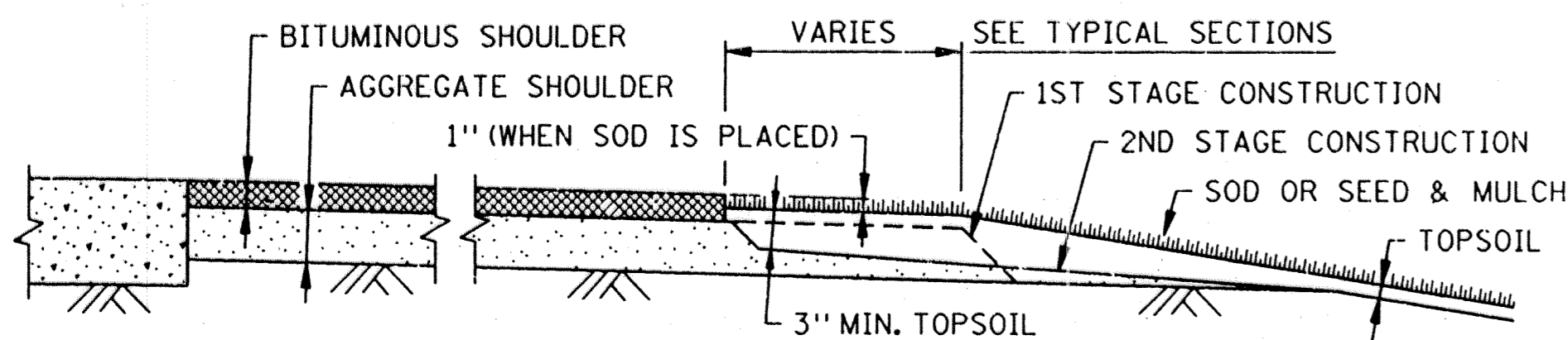

SHAPING AND TOPSOILING INSLOPES

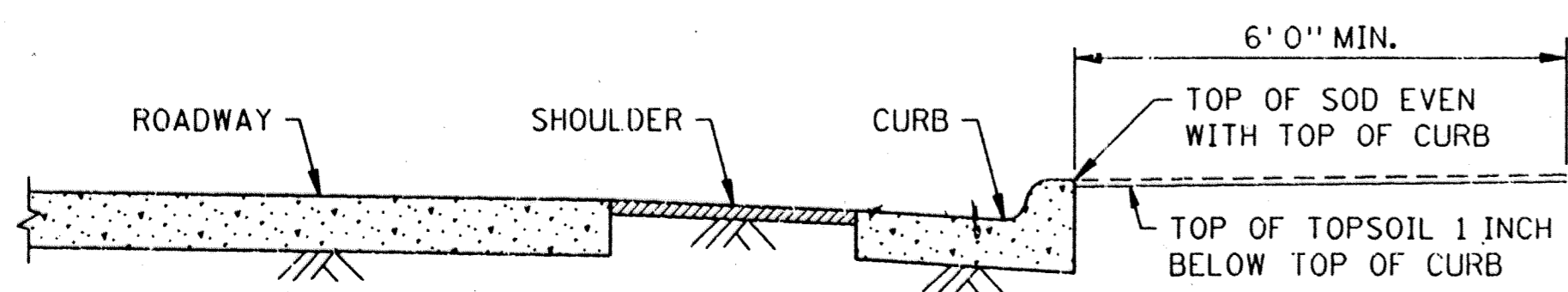

SHAPING ADJACENT TO CURBS WHEN SOD IS PLACED

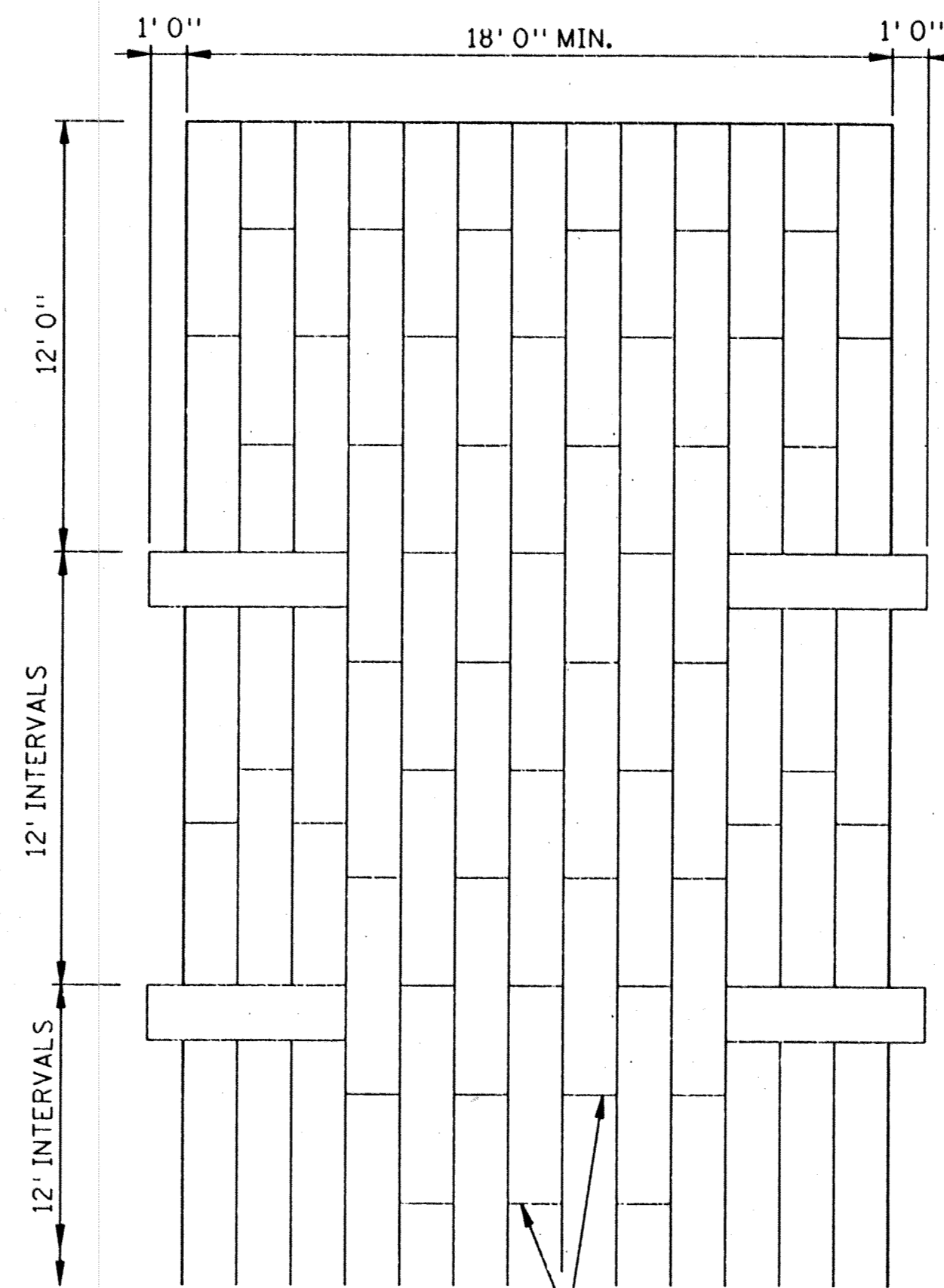

STAGGER JOINTS  
PLAN VIEW

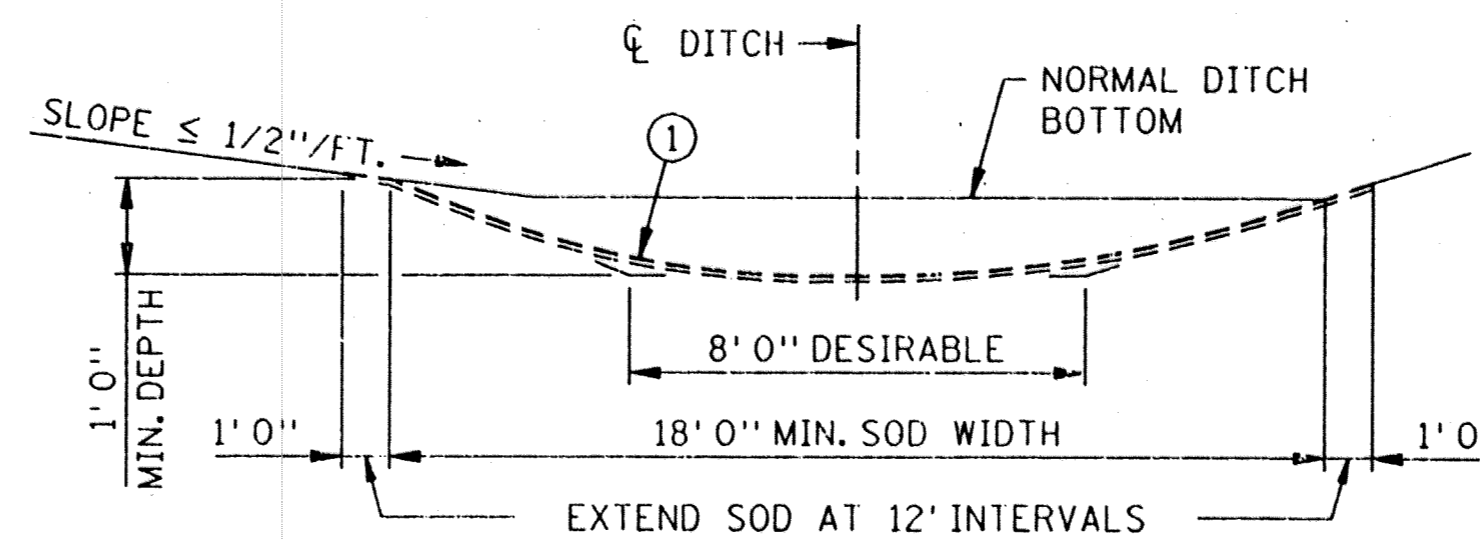

SODDED DITCH CROSS SECTION  
WHERE FRONT OR BACK SLOPE IS FLAT (LESS THAN 1/2"/FT.),  
FIRST NOTCH DITCH AND THEN PROVIDE ROUNDING.

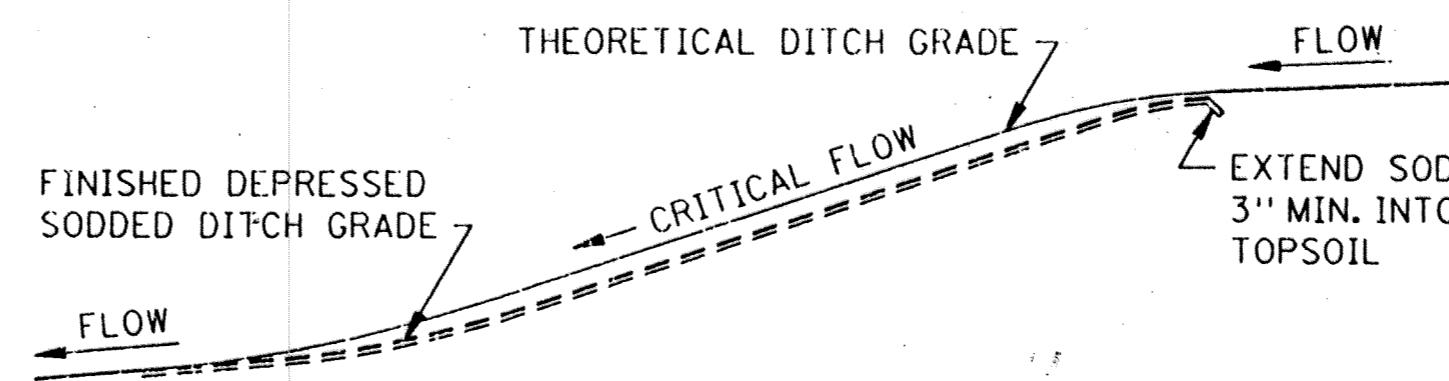

DITCH PROFILE  
SODDED DITCH DETAILS

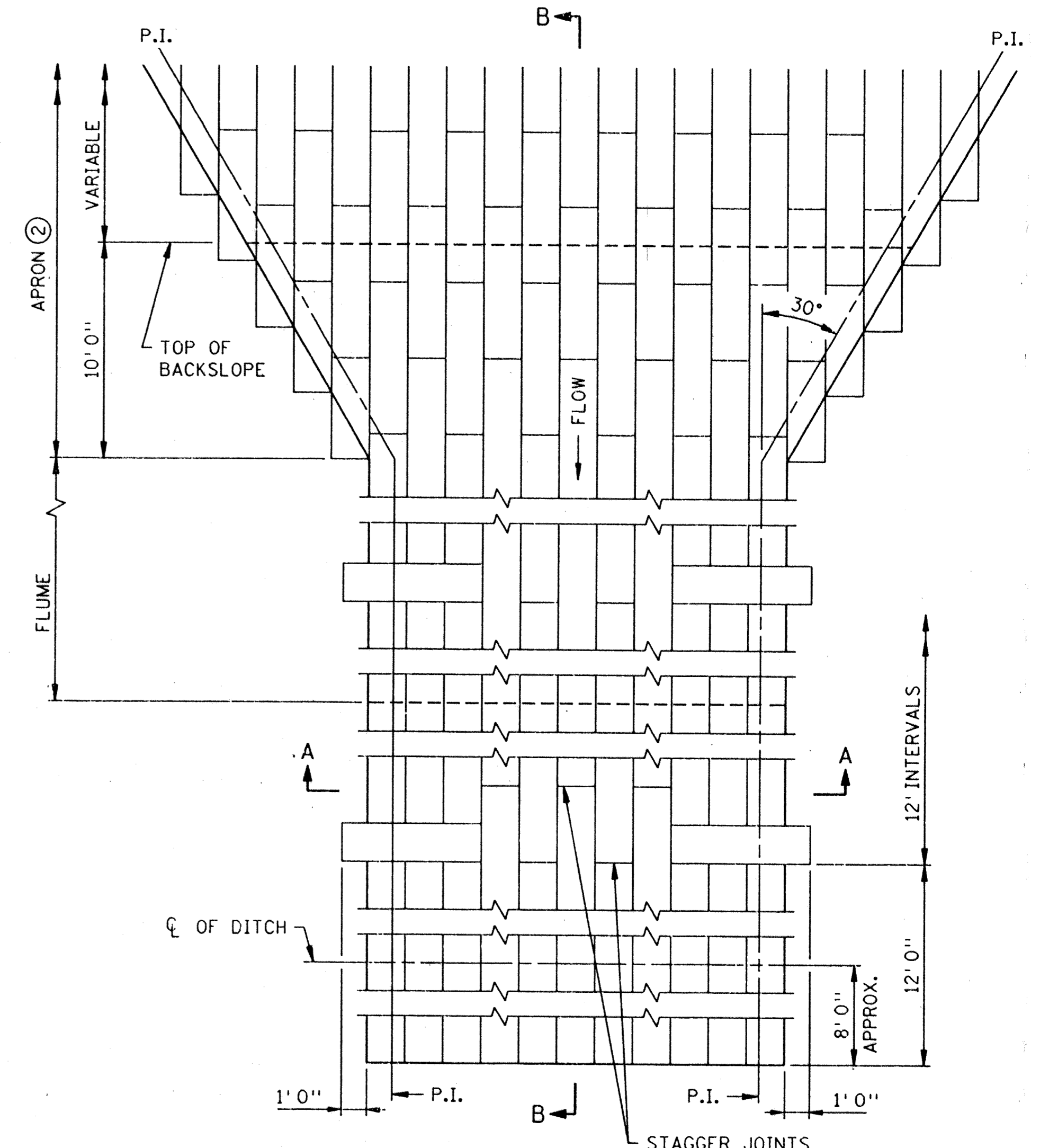

PLAN VIEW

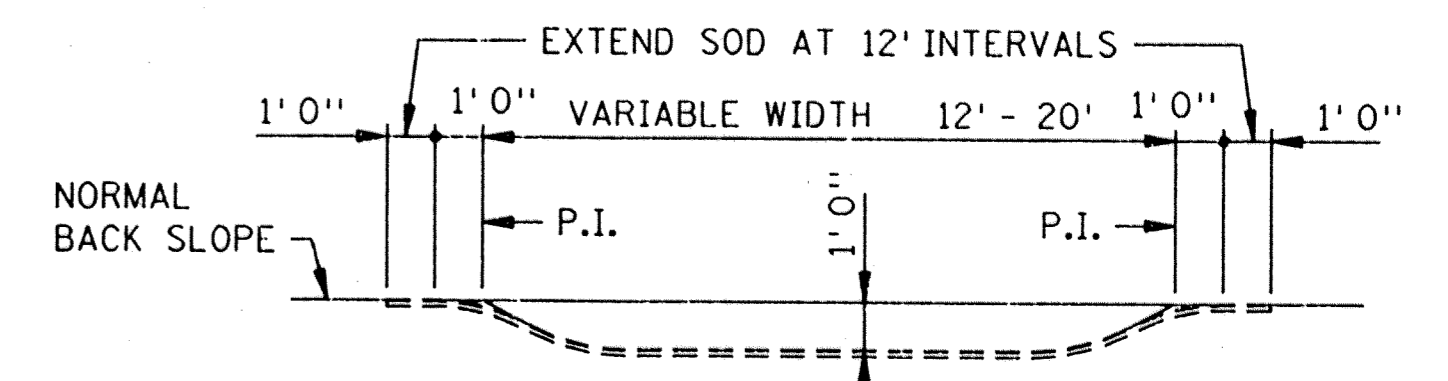

SECTION A-A

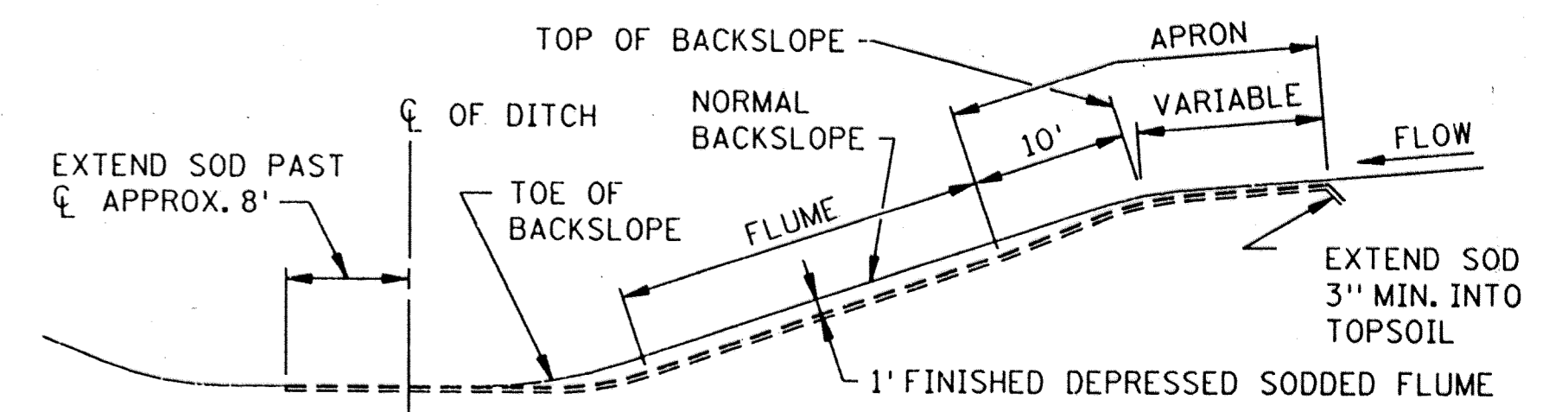

SECTION B-B  
SODDED FLUME DETAILS

- NOTES:  
 SEE SPEC. 2575.3 FOR ADDITIONAL INFORMATION.  
 ① FOR ROUNDING, SEE ROAD DESIGN MANUAL.  
 ② CONSTRUCT TAPER AS DIRECTED BY THE ENGINEER.

STANDARD SHEET NO. 5-297.404	TITLE: PERMANENT EROSION CONTROL ALONG ROADWAYS, DITCHES AND FLUMES
STANDARD APPROVED: DECEMBER 19, 1990	
STATE PROJ. NO. 93-04-60	SHEET NO. 8 OF 42 SHEETS



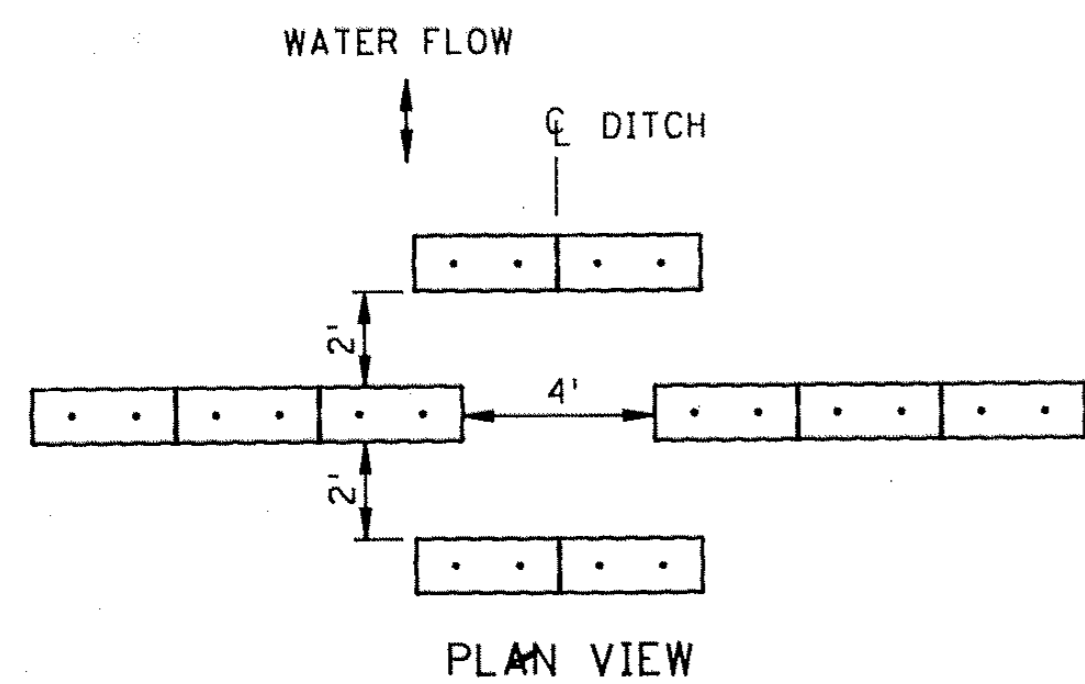

PLAN VIEW

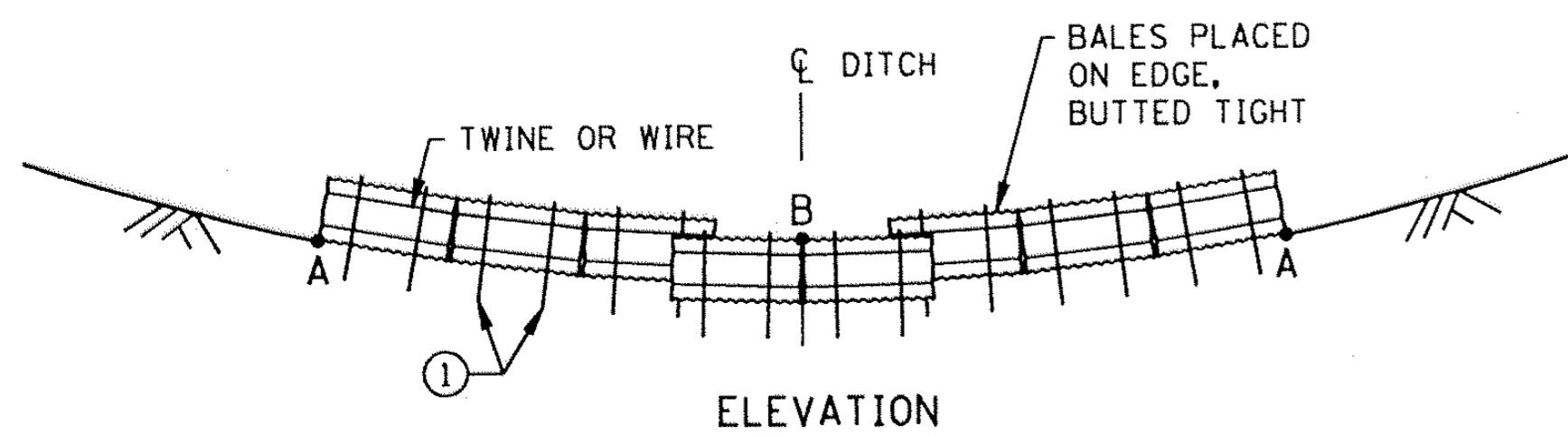

ELEVATION

NOTE:  
POINT A MUST BE HIGHER THAN POINT B  
**BALE DITCH VELOCITY CHECKS**  
( WILL REQUIRE A MINIMUM OF 10 BALES PER SITE )

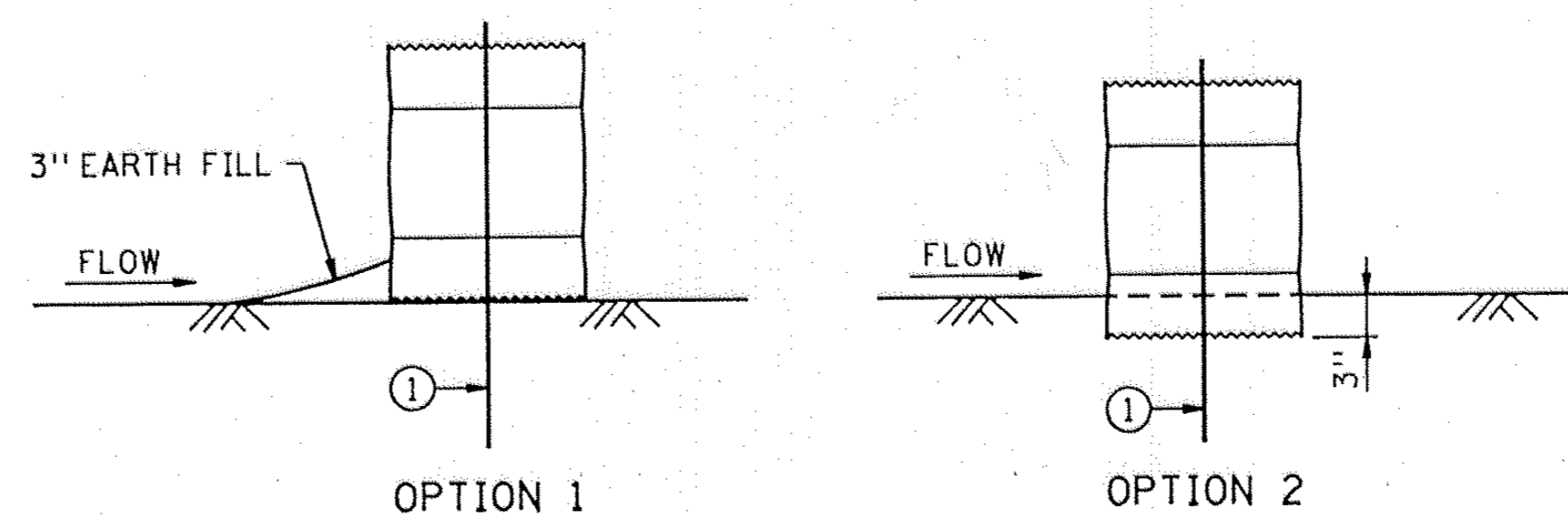

BALE CHECK DETAILS

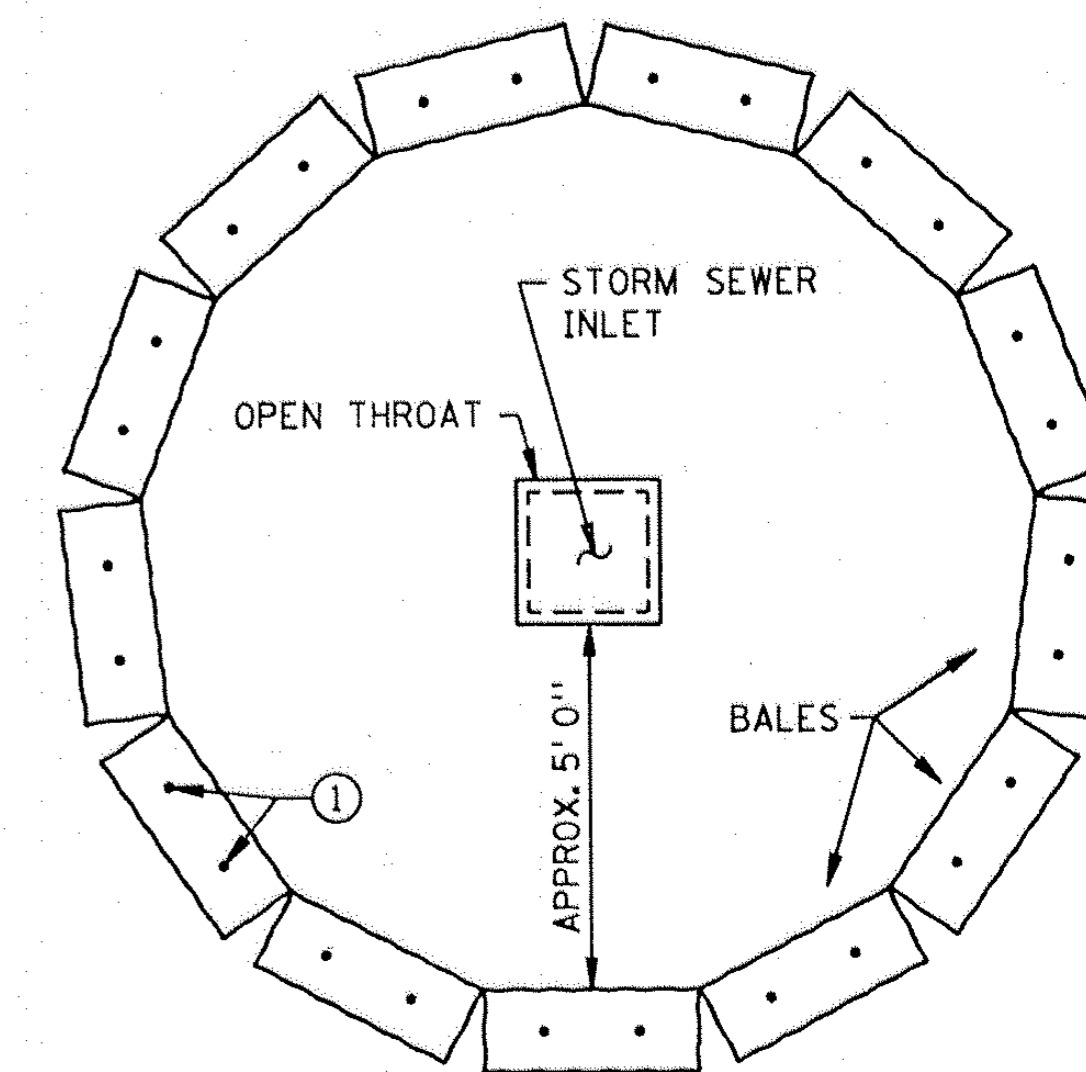

BALE CHECK  
TO PROTECT STORM SEWER INLETS

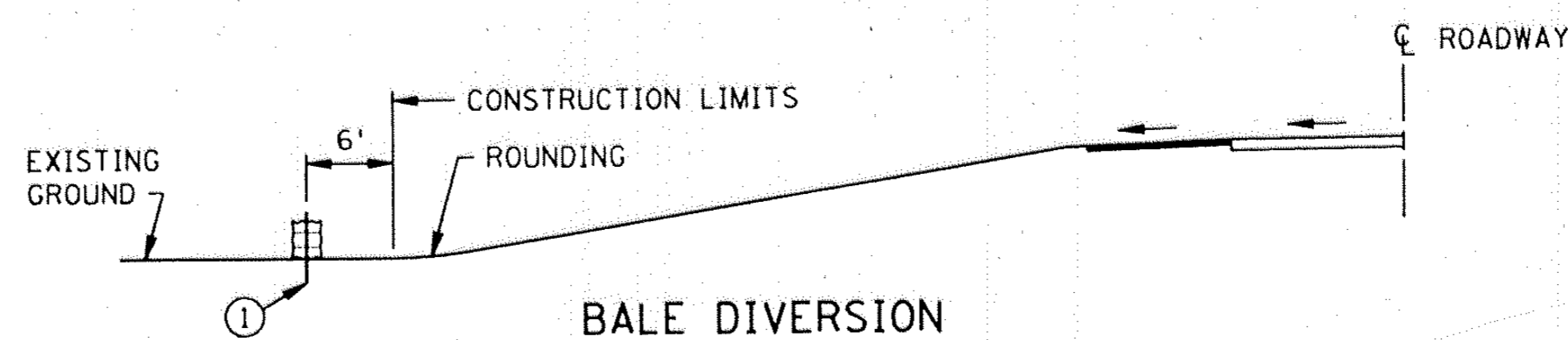

BALE DIVERSION

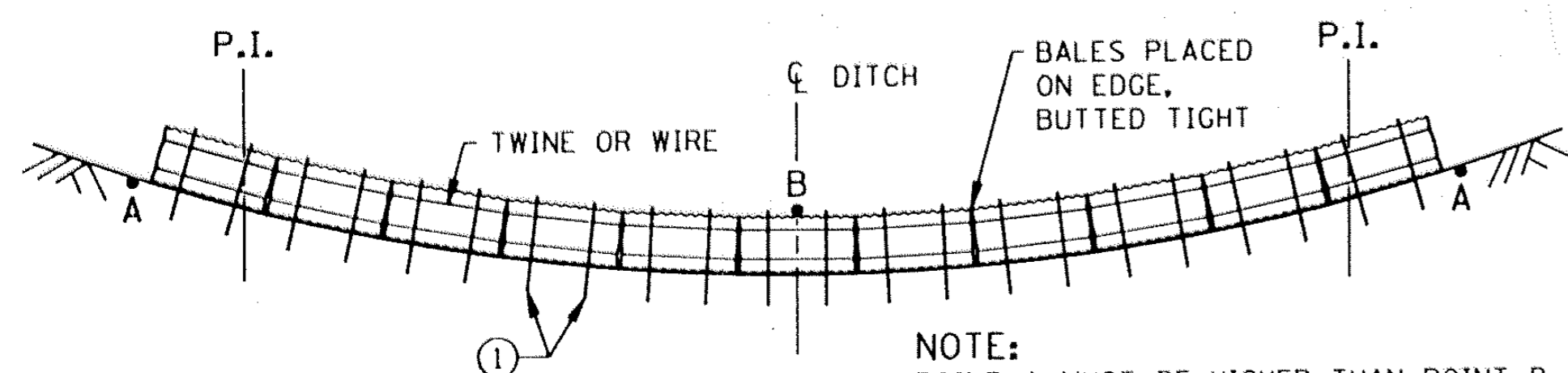

BALE DITCH SEDIMENT CHECK

NOTE:  
POINT A MUST BE HIGHER THAN POINT B

RECOMMENDED SPACING BETWEEN BALE DITCH CHECKS	
DITCH GRADE (%)	SPACING (FT.)
2	100
4	75
6	50
8	40
10	25

NOTE:  
① TWO 2" X 2" WOOD STAKES OR REINFORCING BARS IN EACH BALE AND EMBEDDED IN THE GROUND 10" MINIMUM.

**GRADING SECTION**

STA. 21+15 TO STA. 129+45

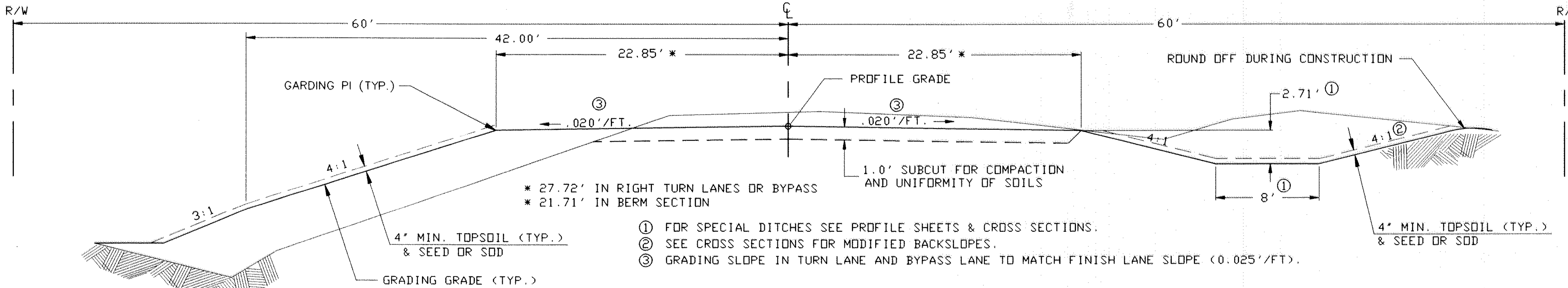

**DESIGN F-1**  
(ALL TRAVEL LANES)

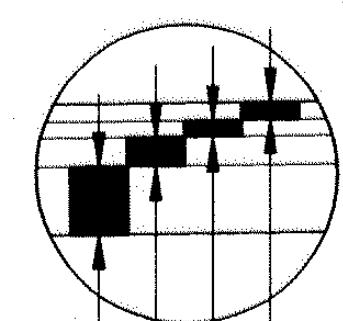

- 1 1/2" TYPE 41 WEARING COURSE-SPEC. 2340 BITUMINOUS MIXTURE DESIGNATION: 41WEA50055Y
- 1 1/2" TYPE 31 BINDER COURSE-SPEC. 2340 BITUMINOUS MIXTURE DESIGNATION: 31BIB50000Y
- 2" TYPE 31 BASE COURSE-SPEC. 2340 BITUMINOUS MIXTURE DESIGNATION: 31BIB50000Y
- 5" AGGREGATE BASE CLASS 5A-SPEC. 2211
- TACK COAT-SPEC. 2357, TO BE APPLIED BETWEEN ALL BITUMINOUS LIFTS.

NOTE: SPECIAL DITCH ELEVATIONS ON THE PLAN & PROFILE AND CROSS SECTION SHEETS ARE FINISHED GRADE ELEVATIONS.

NOTE: RECOVERY AREA IS 42' FROM CENTERLINE. ALL UTILITY POLES AND UNYIELDING OBJECTS SHALL BE REMOVED AND RELOCATED OUTSIDE THE 42' RECOVERY AREA.

**BASE AND BITUMINOUS SECTION**

STA. 21+15 TO STA. 129+45

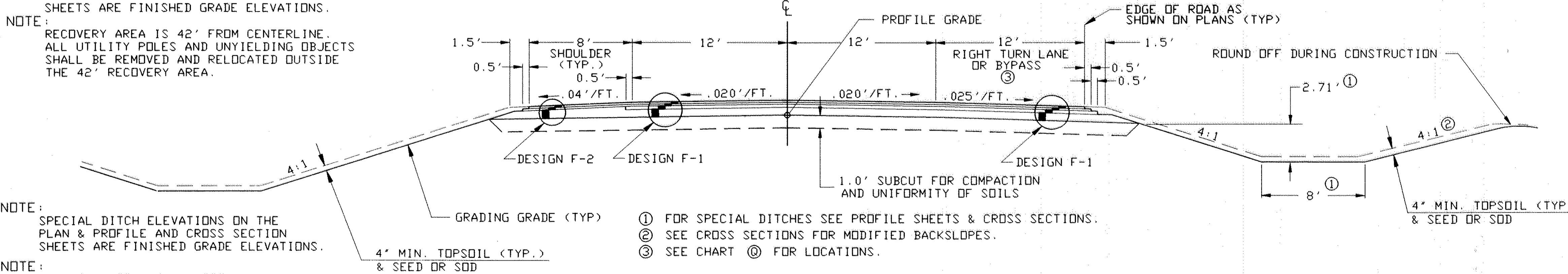

**DESIGN F-2**  
(ALL SHOULDERS)

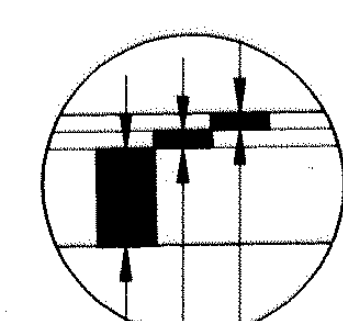

- 1 1/2" TYPE 41 WEARING COURSE-SPEC. 2340 BITUMINOUS MIXTURE DESIGNATION: 41WEA50055Y
- 1 1/2" TYPE 31 BINDER COURSE-SPEC. 2340 BITUMINOUS MIXTURE DESIGNATION: 31BIB50000Y
- VARIABLE DEPTH AGGREGATE BASE CLASS 5A SPEC. 2211
- TACK COAT-SPEC. 2357, TO BE APPLIED BETWEEN ALL BITUMINOUS LIFTS.

NOTE: SPECIAL DITCH ELEVATIONS ON THE PLAN & PROFILE AND CROSS SECTION SHEETS ARE FINISHED GRADE ELEVATIONS.

NOTE: RECOVERY AREA IS 42' FROM CENTERLINE. ALL UTILITY POLES AND UNYIELDING OBJECTS SHALL BE REMOVED AND RELOCATED OUTSIDE THE 42' RECOVERY AREA.

**MUCK EXCAVATION**

STA. 21+15 TO STA. 129+45

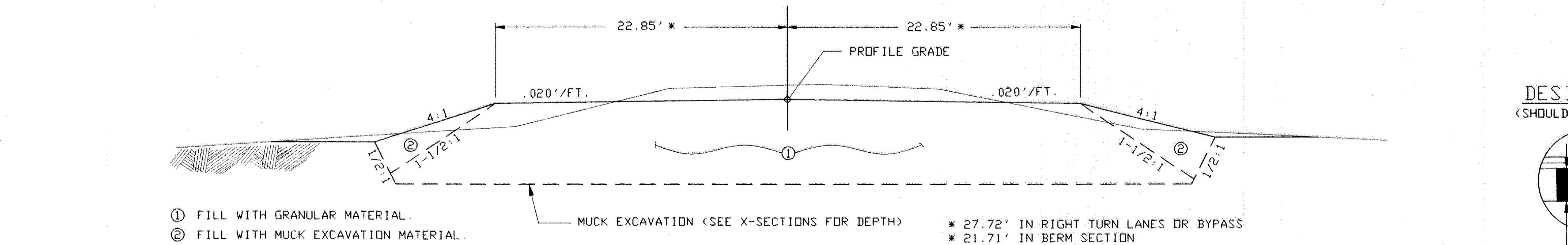

**DESIGN F-3**  
(BITUMINOUS OVERLAY)

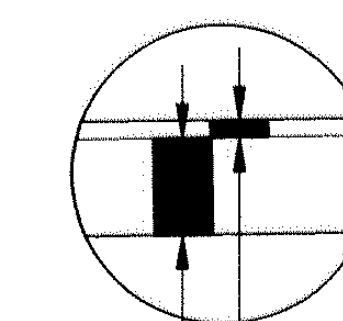

- 1 1/2" TYPE 41 WEARING COURSE-SPEC. 2340 BITUMINOUS MIXTURE DESIGNATION: 41WEA50055Y
- 1 1/2" TYPE 31 BINDER COURSE-SPEC. 2340 BITUMINOUS MIXTURE DESIGNATION: 31BIB50000Y
- 6" AGGREGATE BASE CLASS 5A -SPEC. 2211
- TACK COAT-SPEC. 2357, TO BE APPLIED BETWEEN ALL BITUMINOUS LIFTS.

**DESIGN F-4**  
(SHOULDER WIDENING)

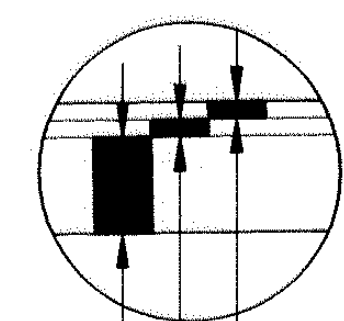

- 1 1/2" TYPE 41 WEARING COURSE-SPEC. 2340 BITUMINOUS MIXTURE DESIGNATION: 41WEA50055Y
- 1 1/2" TYPE 31 BINDER COURSE-SPEC. 2340 BITUMINOUS MIXTURE DESIGNATION: 31BIB50000Y
- 6" AGGREGATE BASE CLASS 5A -SPEC. 2211
- TACK COAT-SPEC. 2357, TO BE APPLIED BETWEEN ALL BITUMINOUS LIFTS.

**BITUMINOUS OVERLAY SECTION**

STA. 16+40 TO STA. 21+15

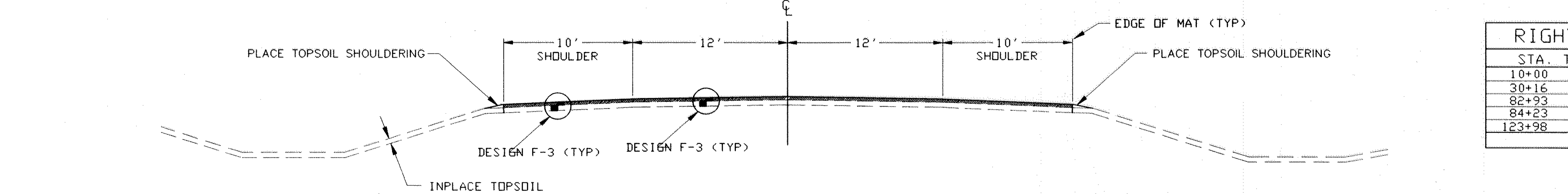

RIGHT TURN LANE AND BYPASS LOCATION ③			
STA. TO	STA.	LOCATION	REMARKS
10+00	16+40	RT CL.	RIGHT TURN LANE
30+16	35+06	RT CL.	RIGHT TURN LANE
82+93	88+51	RT CL.	RIGHT TURN LANE
84+23	91+93	LT CL.	BYPASS
123+98	129+45	RT CL.	BYPASS

TYPICAL SECTIONS

**BITUMINOUS OVERLAY SECTION**

STA. 10+00 TO STA. 12+50

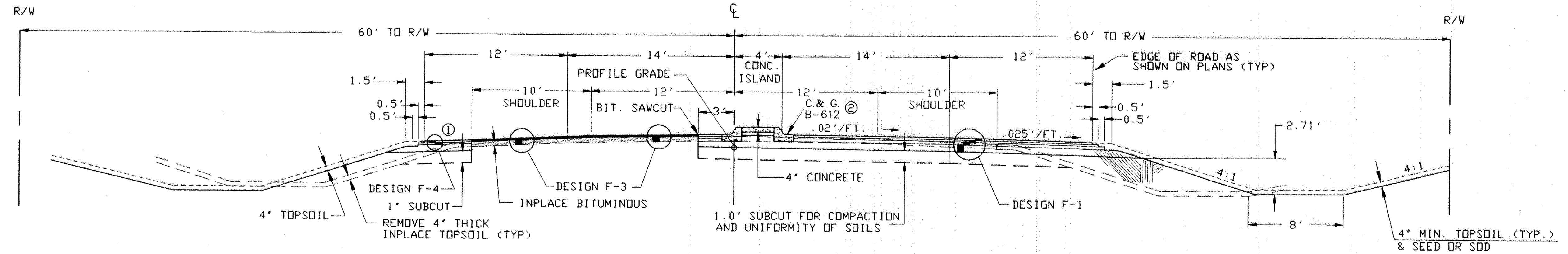

- ① - SHOULDER WIDENING STA. 11+90 TO STA. 12+85
- ② - CONSTRUCTION CURB AND GUTTER DESIGN B-612 SLOPE OUT

**BITUMINOUS OVERLAY SECTION**

STA. 12+50 TO STA. 16+40

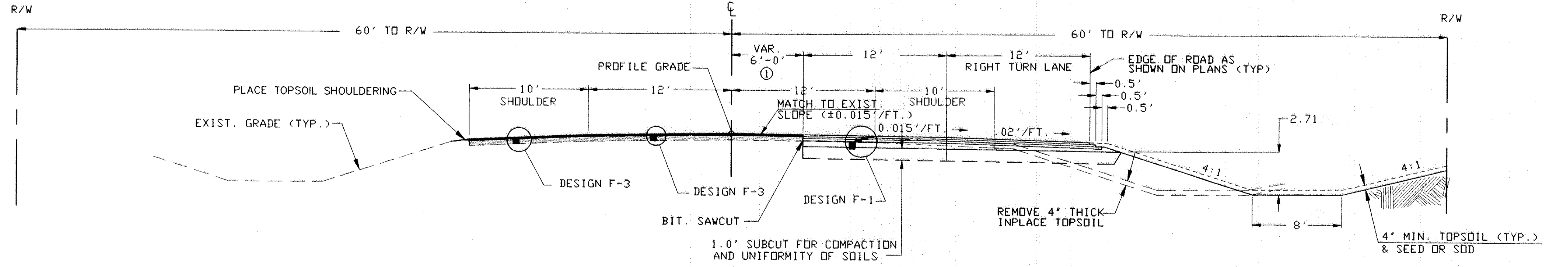

- ① - STA. 12+50 TO STA. 13+40, 6'. AND FROM STA. 13+40 TO STA. 16+40 VAR. 6' TO 0', 50:1

REVISIONS	DATE	BY

FILE NAME: \P\930460\TAB-CH.DWG MN. 04-20-96

B.M. #1 ELEV. 913.47  
TOP S.W. COR TOP STEP (CHURCH)  
STA. 19+00 170' LT.

HAM LAKE BAPTIST CHURCH

COMM. BLDG. 1515

STALLION CUSTOMS 16307

TOM THUMB

BEG. COUNTY PROJ. 93-04-60 &  
BEG. BITUMINOUS OVERLAY  
STA. 10+00.00

T.H. 65

N 127098.55  
E 897116.44  
SIXT-L S88°14'39"E (1324.09')

BIT SAWCUT, 63'RT.CL

ROAD C/L S88°14'39"E (2407.19')

CONSTANCE BLVD. NE C.R. 60

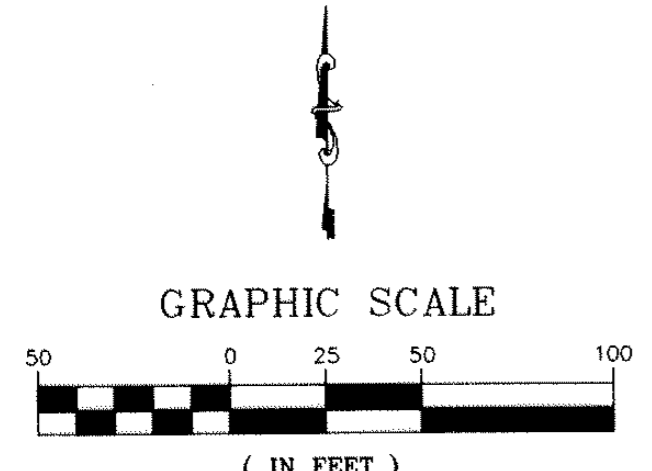

WETLAND  
BITUMINOUS REMOVAL

B.M. #2 ELEV. 912.30  
TOP S.W. COR TOP STEP  
STA. 22+40 LT. #1609

NOTE: SEE SHEET 6 AND SPECIAL PROVISIONS  
FOR SPECIAL CONDITIONS FOR WORK  
PERFORMED ON PARCELS 1,2,4,9 AND 10.

BEG. BITUMINOUS REMOVALS  
STA. 21+15

1609 GAR

1619 GAR

1629

1639

1647/1651

1659

1711

1719

1729

1741

1741

SEPTIC TANK

SEPTIC TANK

SEPTIC TANK

SEPTIC TANK

SEPTIC TANK

SEPTIC TANK

SEPTIC TANK

SEPTIC TANK

SEPTIC TANK

SEPTIC TANK

DRAINFIELD

DRAINFIELD

DRAINFIELD

DRAINFIELD

DRAINFIELD

DRAINFIELD

DRAINFIELD

DRAINFIELD

DRAINFIELD

DRAINFIELD

P.I. 21+68.68  
N 127139.72  
E 898459.49  
SIXT-L S88°14'39"E (1324.09')

REMOVE 18"x72'CMP

BIT SAWCUT, 62'RT.CL

16251

REMOVE 15"x 82'CMP

BIT.SAWCUT, 56'RT.CL

16254

REMOVE C.B. STRUCTURE

REMOVE 12"x46'CMP

REMOVE 15"x 82'CMP

REMOVE 12"x46'CMP

REMOVE 15"x 82'CMP

REMOVE 12"x46'CMP

REMOVE 15"x 82'CMP

REMOVE 12"x46'CMP

REMOVE 15"x 82'CMP

REMOVE 12"x46'CMP

REMOVE 15"x 82'CMP

REMOVE 12"x46'CMP

REMOVE 15"x 82'CMP

REMOVE 12"x46'CMP

B.M. #4 ELEV. 912.56  
N.W. COR CONC LIGHT BASE  
STA. 30+20, 200' RT.

WETLAND  
BITUMINOUS REMOVAL

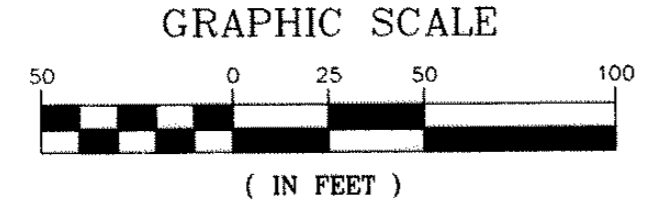

EXISTING CONDITIONS  
AND REMOVAL PLAN  
STA. 10+00 TO 36+00

REVISIONS	DATE	BY

B.M. #5 ELEV. 914.99  
DBL SPIKE IN P.P.  
STA. 27+65.33' LT.

B.M. #6 ELEV. 912.90  
DBL SPIKE IN P.P.  
STA. 43.70, 33' LT.

B.M. #7 ELEV. 913.49  
DBL SPIKE IN P.P. MANKATO  
STA. 49+85, 100' LT.

PARCEL  
13  
2045

PI. 48+36.33  
N 127156.74  
E 901126.40  
SIXT-L S88°57'17"E (1324.09') 40'S.E.

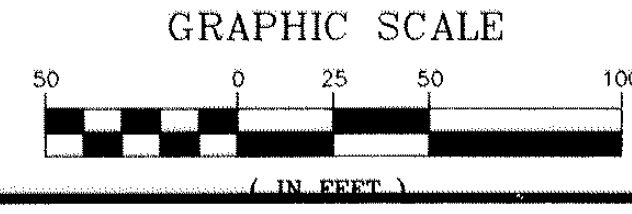
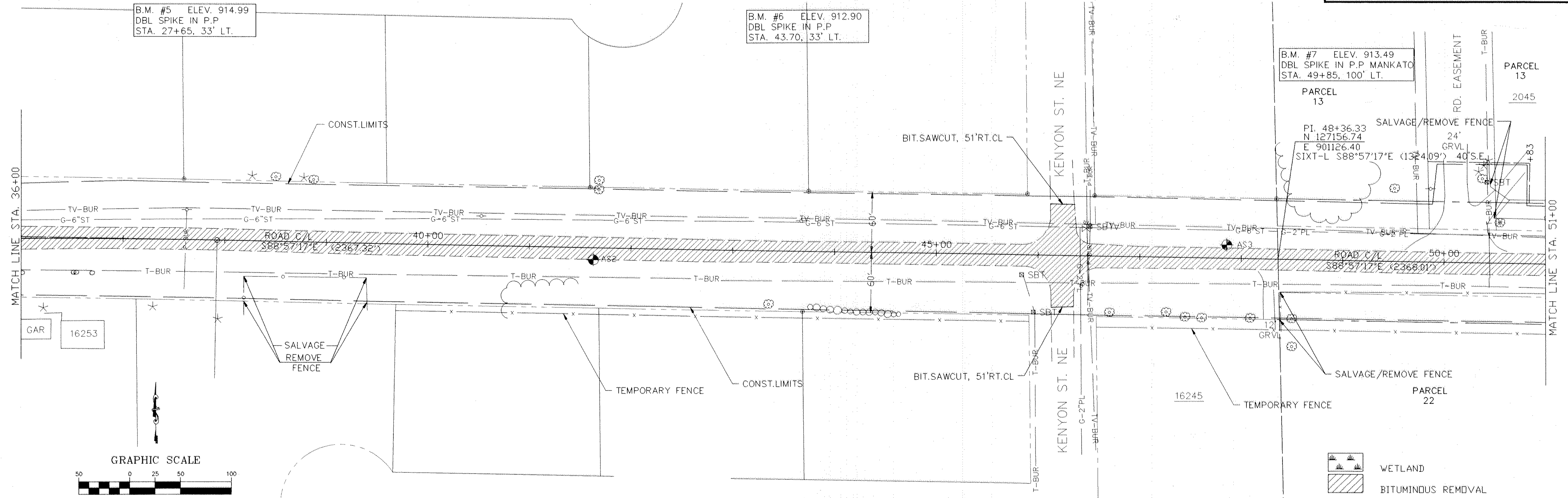

WETLAND  
 BITUMINOUS REMOVAL

PARCEL 13

B.M. #8 ELEV. 914.08  
DBL SPIKE IN P.P.  
STA. 55+75, 33' LT.

PARCEL 14

B.M. #9 ELEV. 914.08  
DBL SPIKE IN P.P. QUAMBA  
STA. 64.40, 100' LT.

PARCEL 14

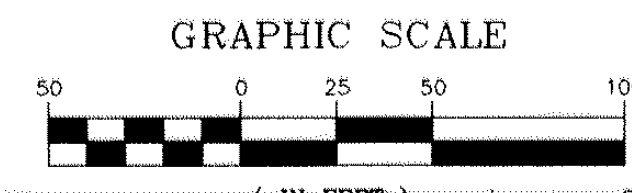
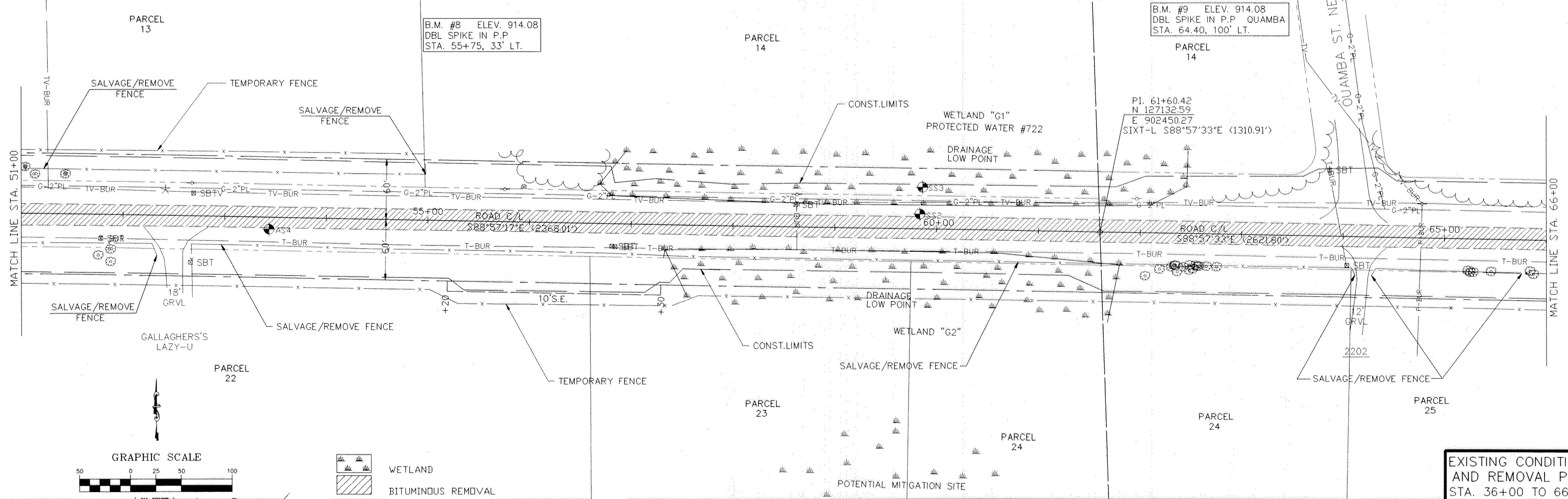

WETLAND  
 BITUMINOUS REMOVAL

EXISTING CONDITIONS AND REMOVAL PLAN  
STA. 36+00 TO 66+00

FILE NAME: NPA930460-EXIST-1.DWG MN 04-30-96

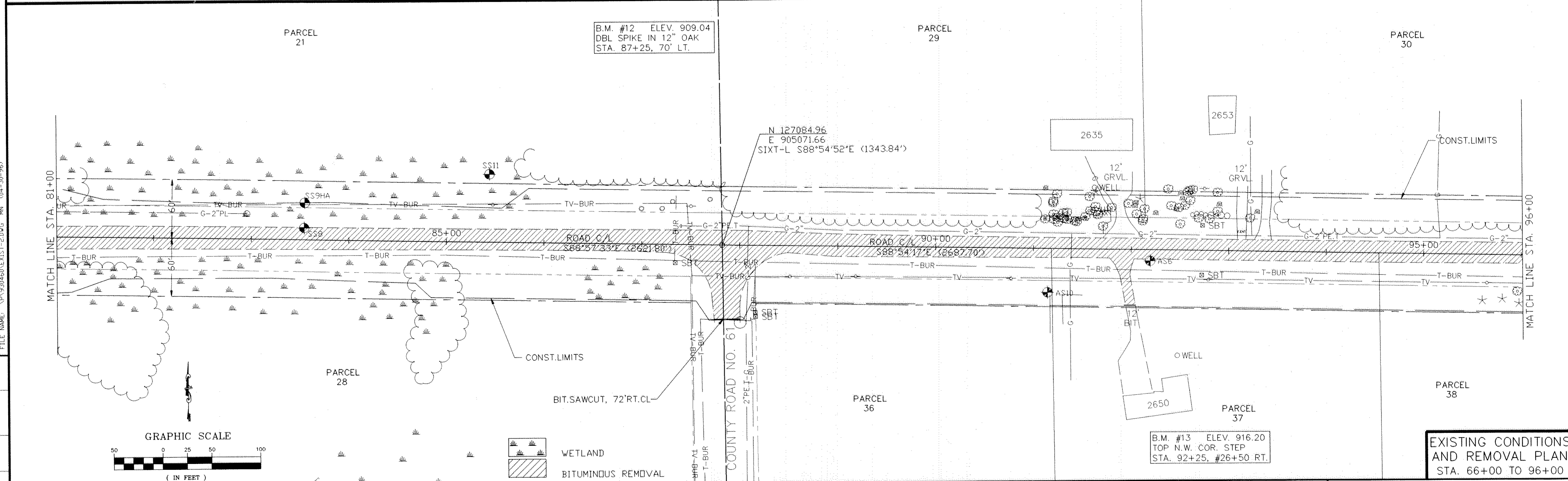
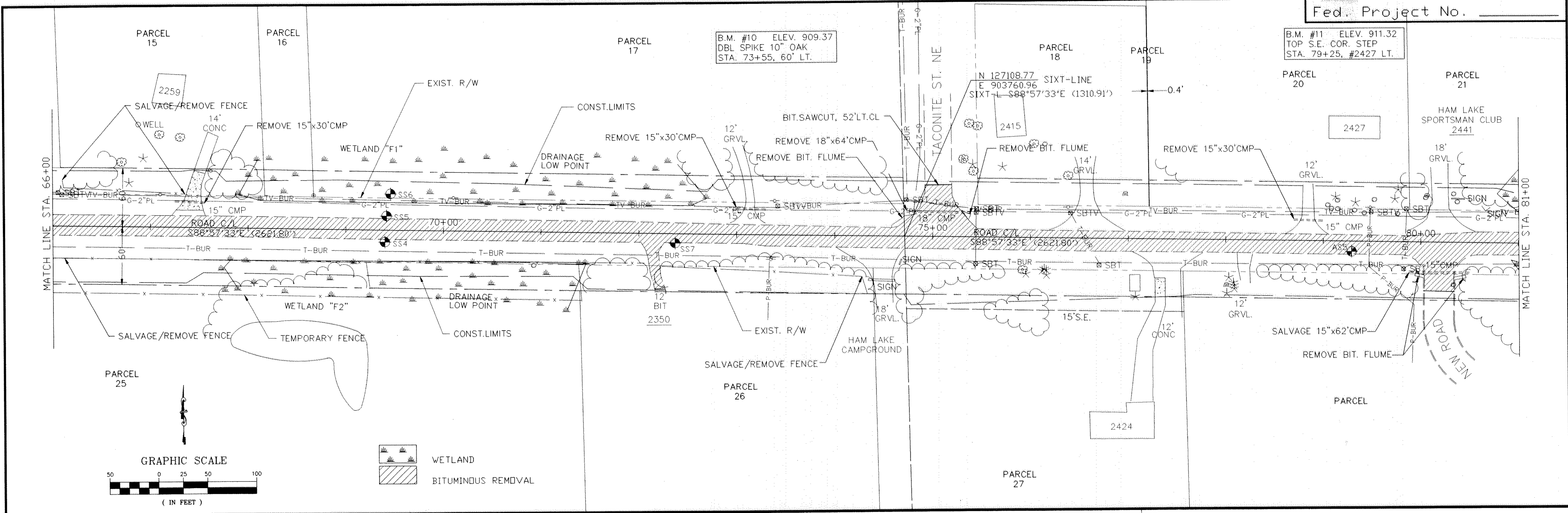

FILE NAME: \P\930460\EXIST-2.DWG. MN. 04-30-96

REVISIONS	DATE	BY

EXISTING CONDITIONS AND REMOVAL PLAN STA. 66+00 TO 96+00

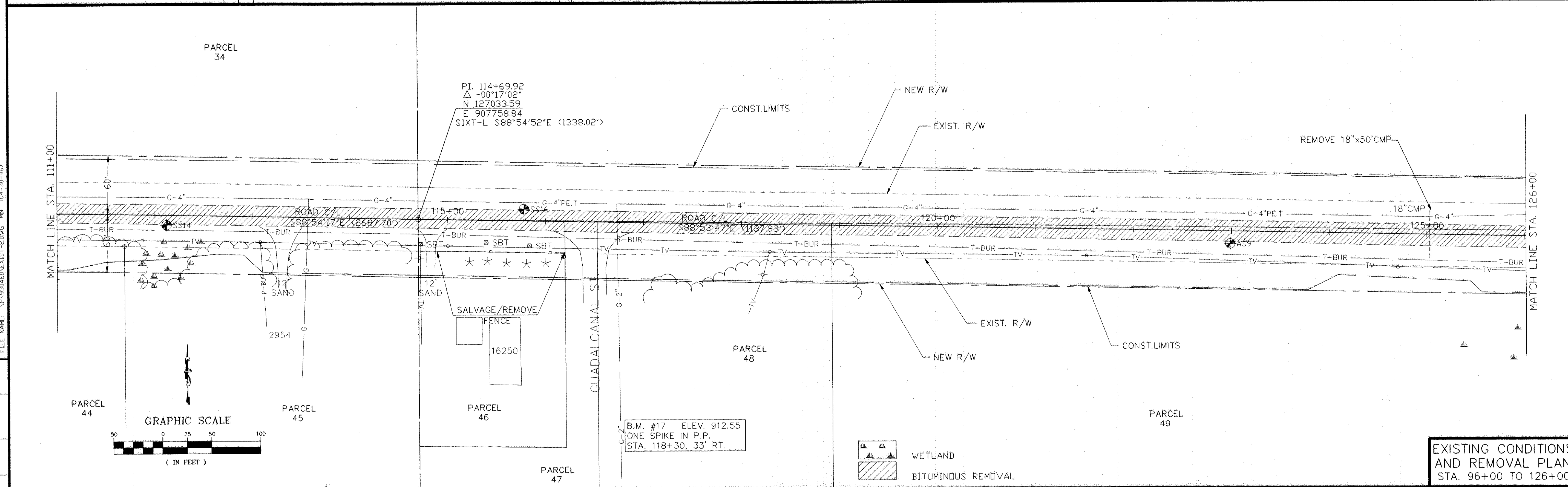
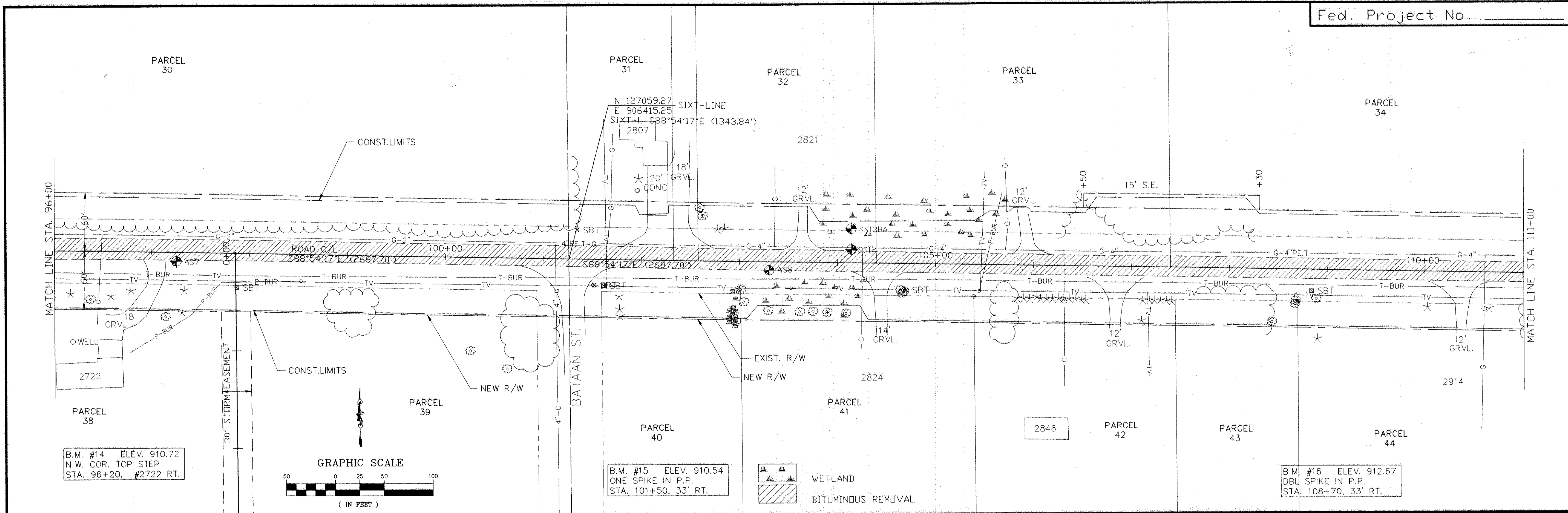

REVISIONS	DATE	BY

EXISTING CONDITIONS AND REMOVAL PLAN STA. 96+00 TO 126+00

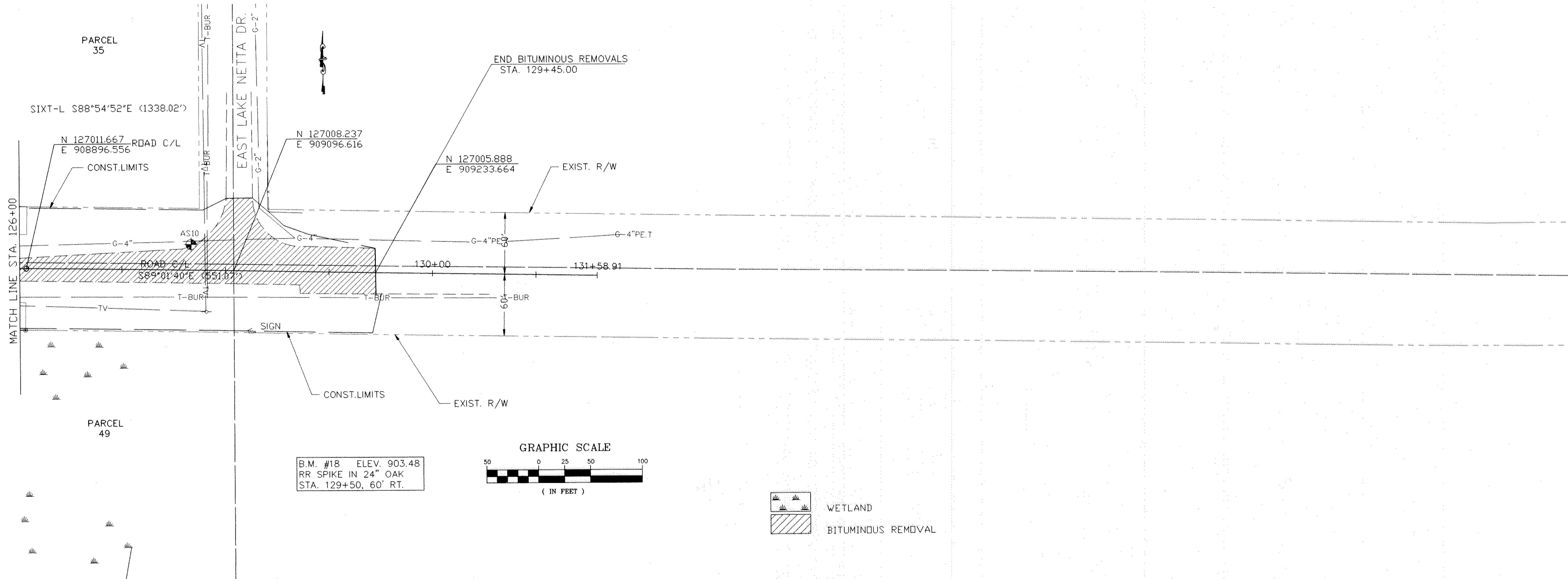

B.M. #18 ELEV. 903.48  
RR SPIKE IN 24" OAK  
STA. 129+50, 60' RT.

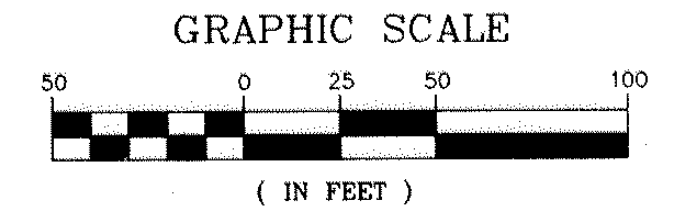

WETLAND  
BITUMINOUS REMOVAL

DATE	BY	REVISIONS

FILE NAME: \PA930460\EXIST-2.DWG MN (04-30-96)

EXISTING CONDITIONS AND REMOVAL PLAN STA. 126+00 TO 131+00



B.M. #1 ELEV. 913.47  
TOP S.W. COR TOP STEP (CHURCH)  
STA. 19+00 170' LT.

HAM LAKE  
BAPTIST  
CHURCH

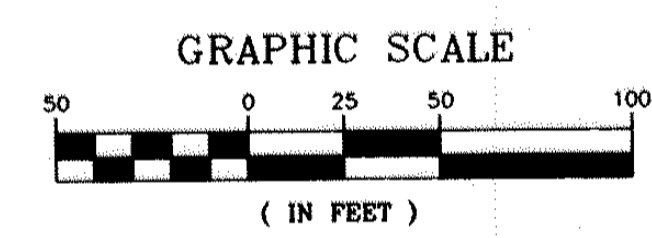
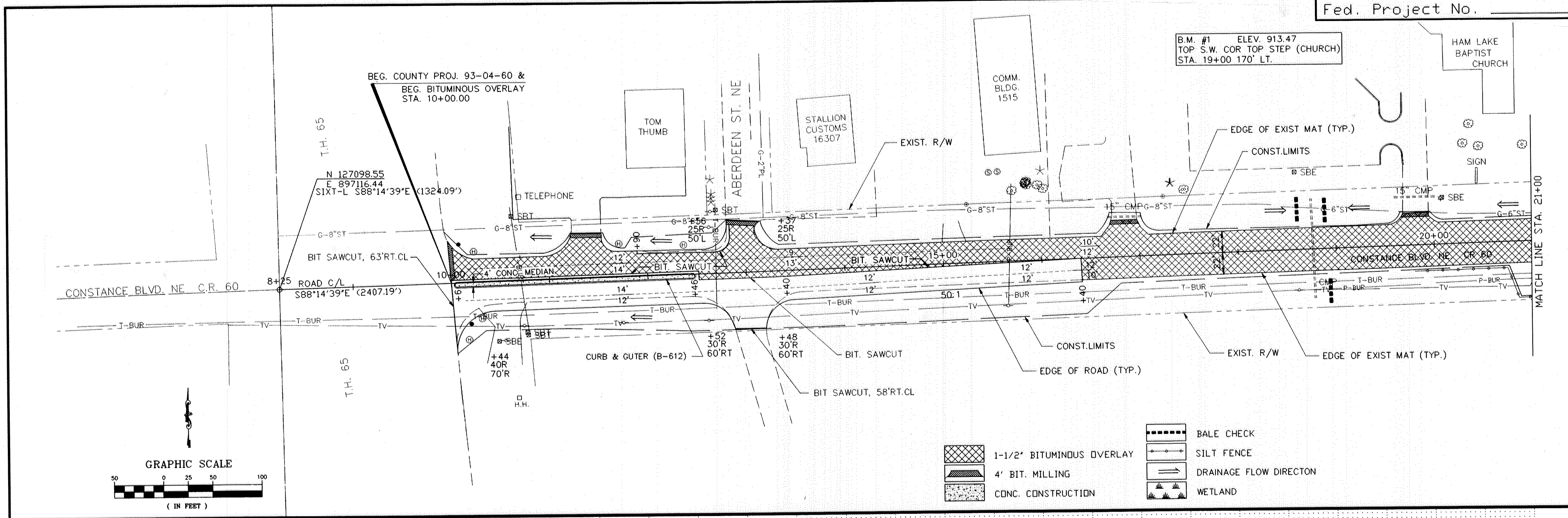

- 1-1/2" BITUMINDUS OVERLAY
- 4" BIT. MILLING
- CONC. CONSTRUCTION
- BAILE CHECK
- SILT FENCE
- DRAINAGE FLOW DIRECTON
- WETLAND

NOTE:  
ALL PROFILE INFO. BASED  
ON GRADING GRADE

NOTE:  
1- THE FINISH BITUMINOUS OVERLAY SURFACE  
SHALL BE MATCHING EXISTING ROAD SURFACE  
SLOPE UNLESS NOTED ON PLANS OTHERWISE.

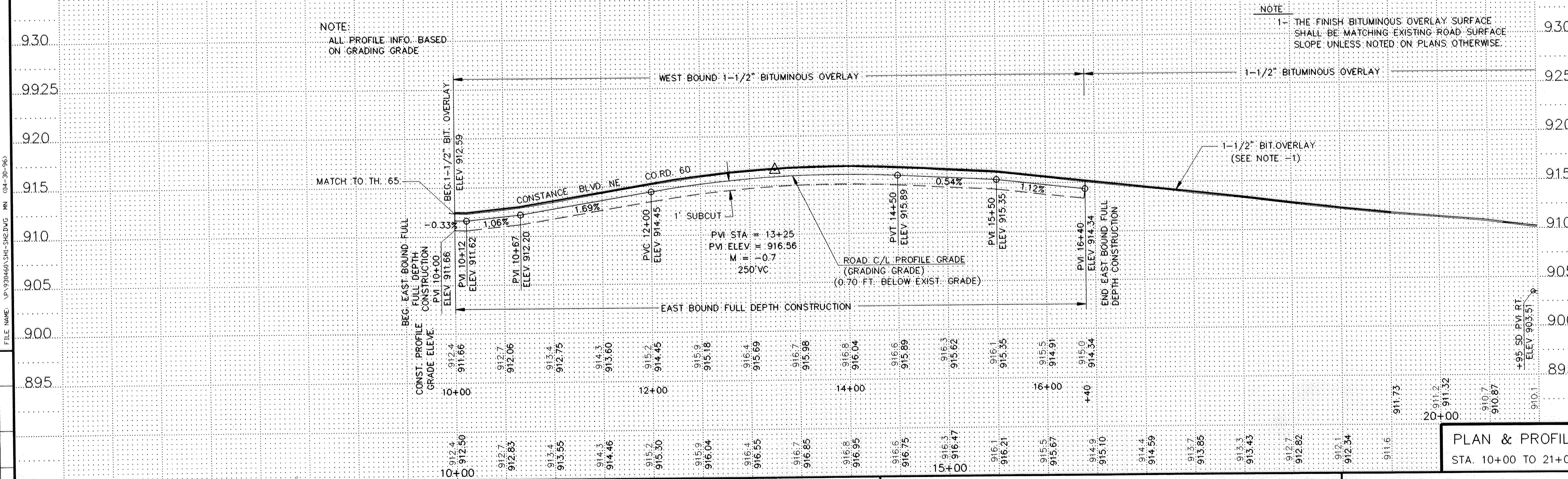

REVISIONS	DATE	BY

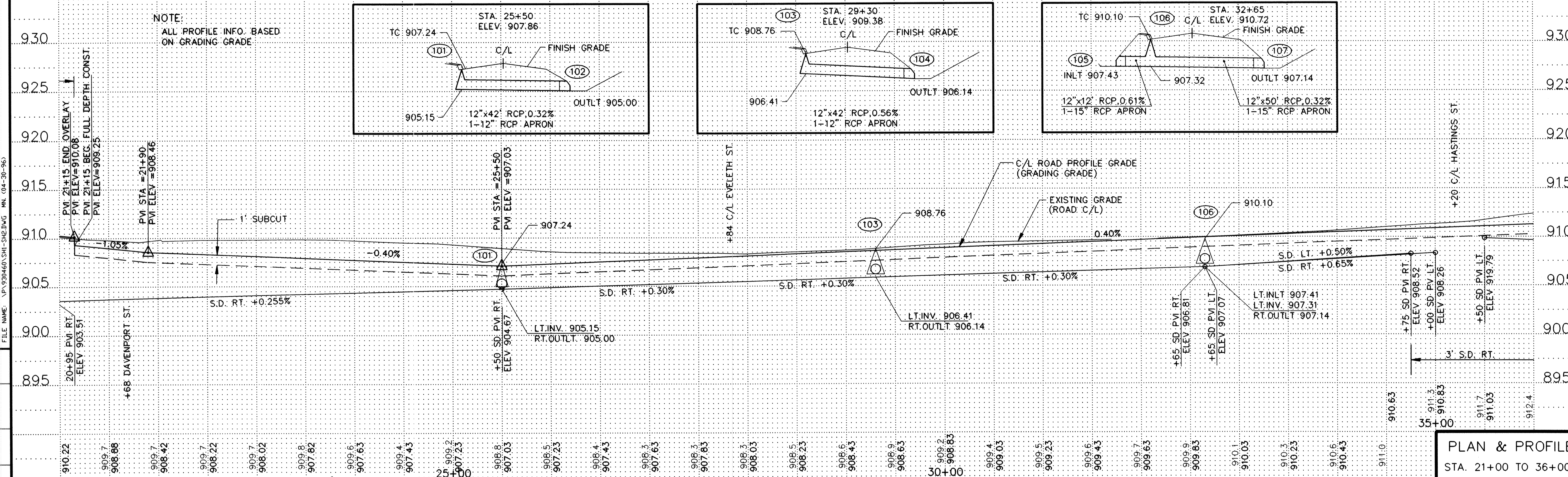
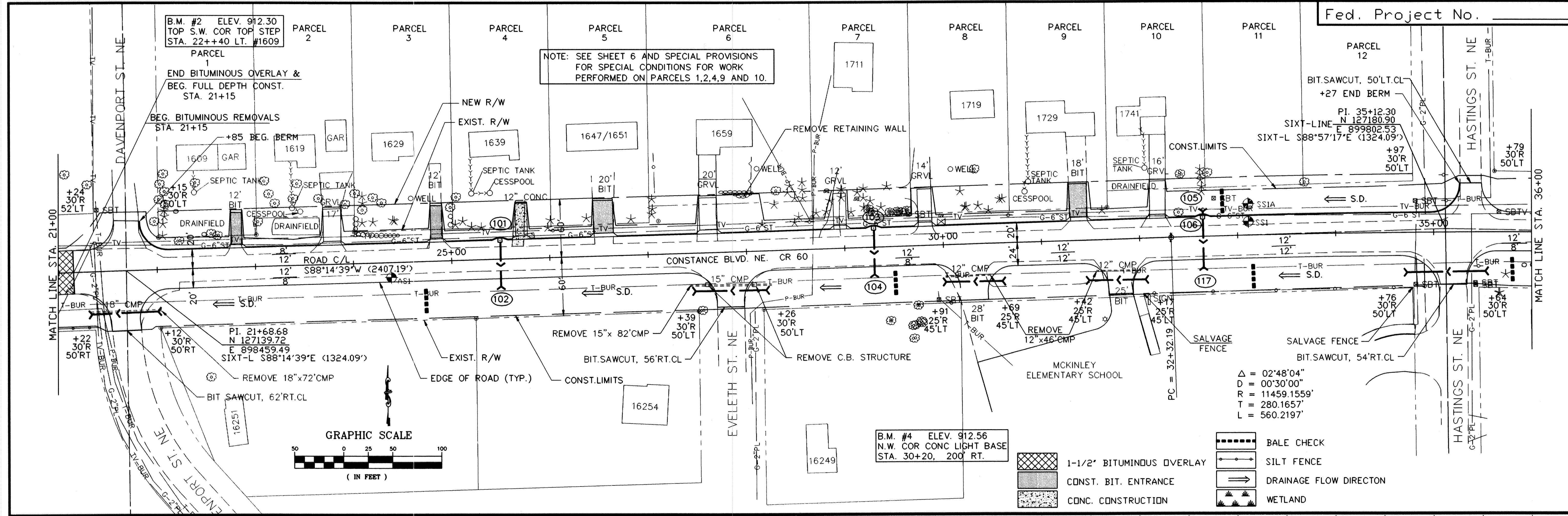

REVISIONS	DATE	BY

B.M. #5 ELEV. 914.99  
DBL SPIKE IN P.P.  
STA. 27+65, 33' LT.

B.M. #6 ELEV. 912.90  
DBL SPIKE IN P.P.  
STA. 43.70, 33' LT.

B.M. #7 ELEV. 913.49  
DBL SPIKE IN P.P. MANKATO  
STA. 49+85, 100' LT.

PARCEL 13  
2045

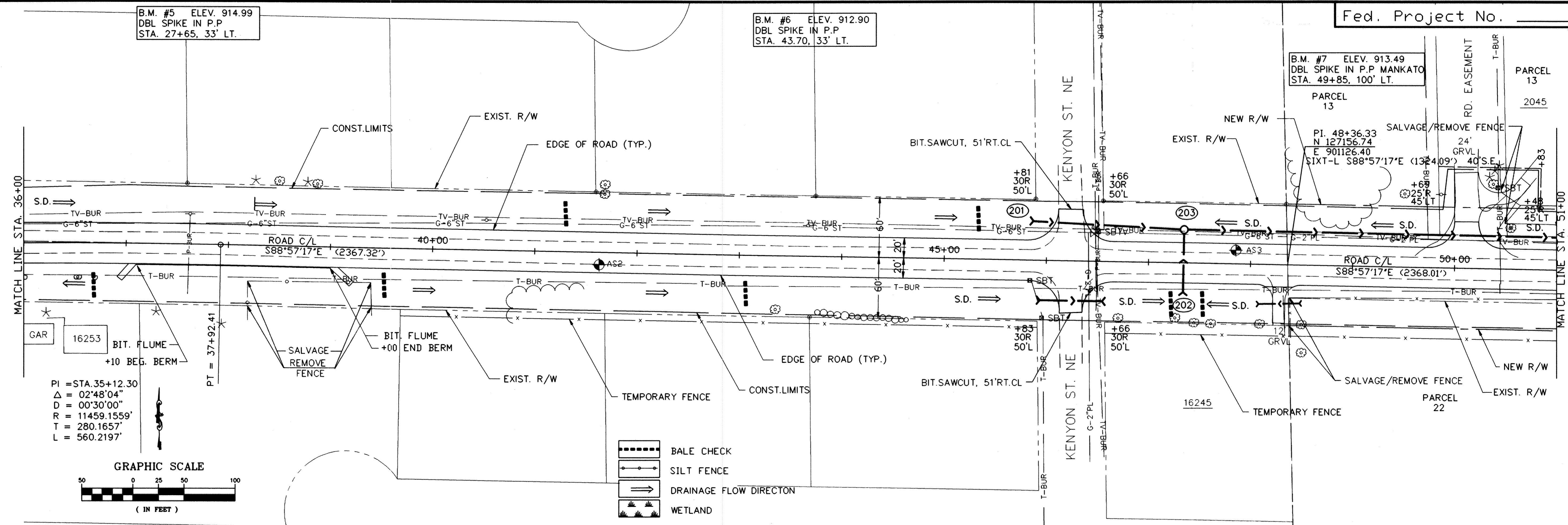

PI = STA. 35+12.30  
Δ = 02°48'04"  
D = 00°30'00"  
R = 11459.1559'  
T = 280.1657'  
L = 560.2197'

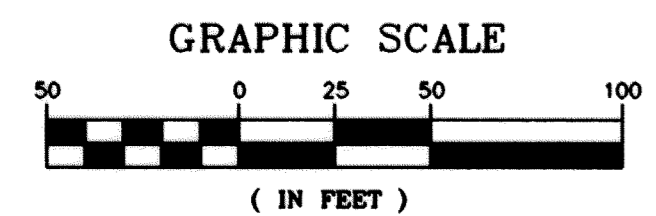

- BALE CHECK
- SILT FENCE
- DRAINAGE FLOW DIRECTION
- WETLAND

NOTE:  
ALL PROFILE INFO. BASED  
ON GRADING GRADE

PVI STA = 38+50  
PVI ELEV = 912.23  
M = -0.09  
100' VC

PVI STA = 45+00  
PVI ELEV = 909.96  
M = 0.10'  
100' VC

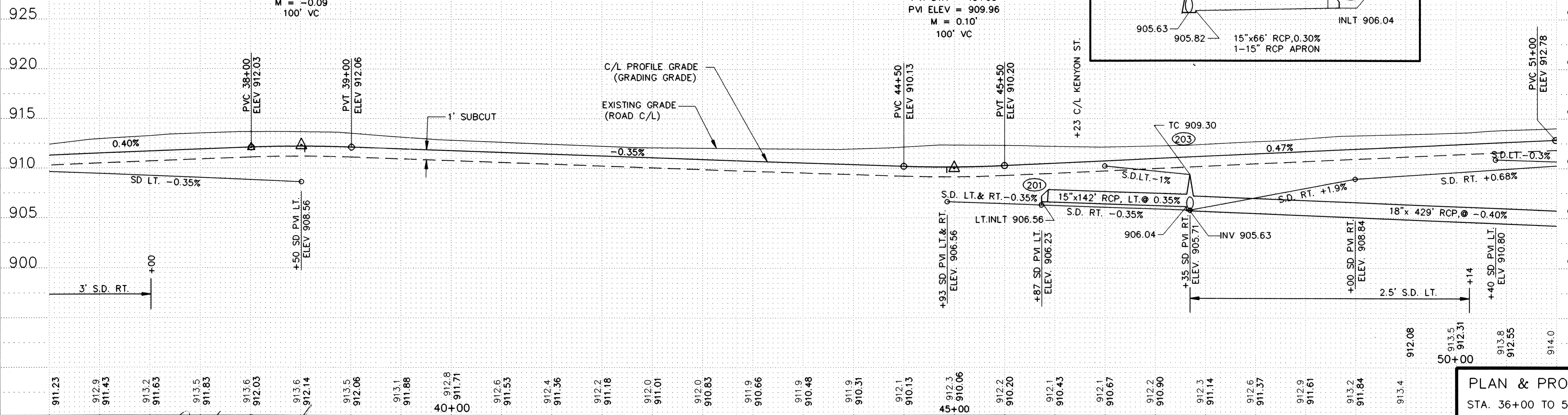
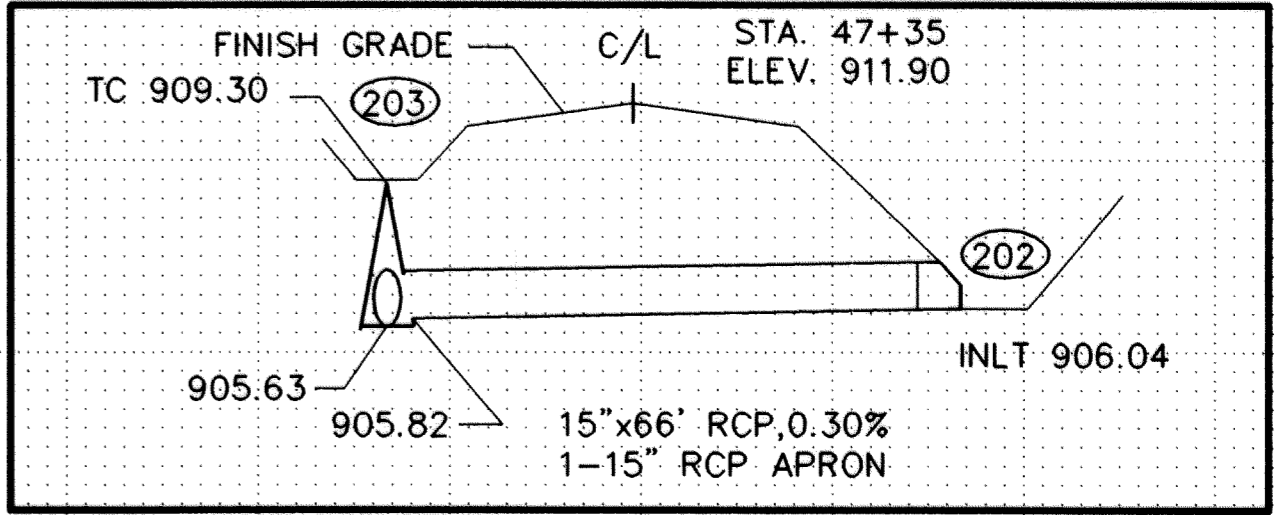

REVISIONS	DATE	BY

PLAN & PROFILE  
STA. 36+00 TO 51+00

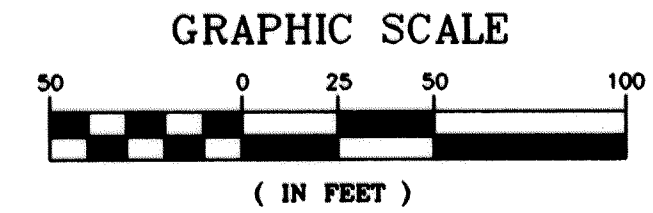
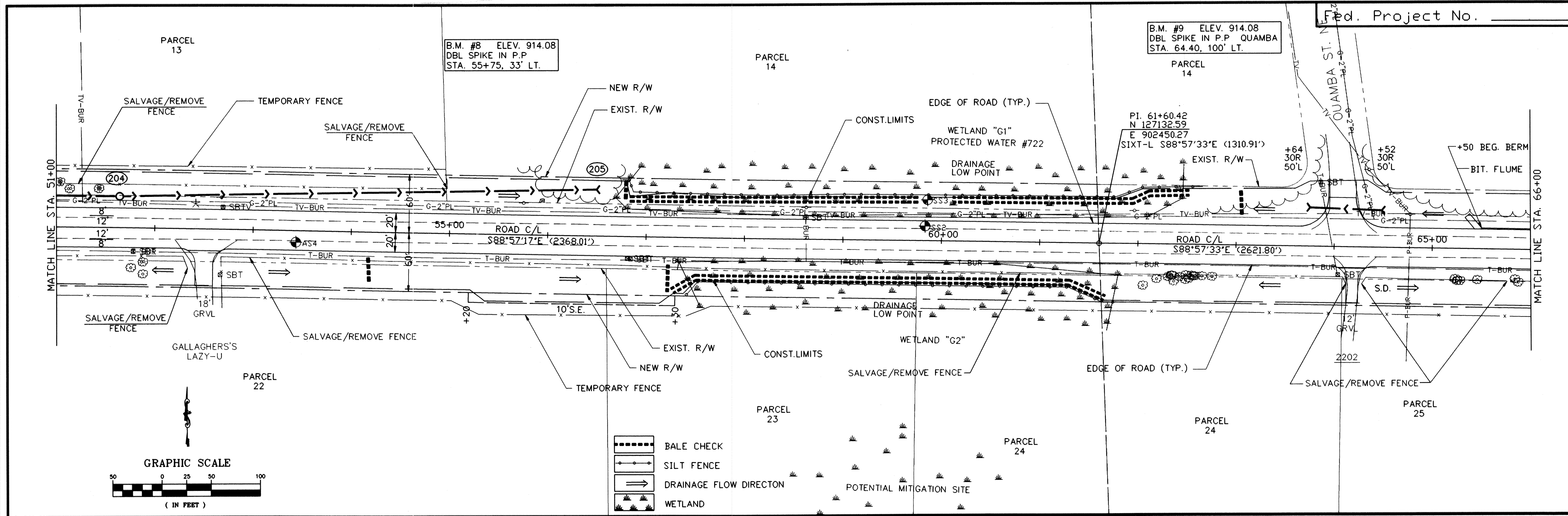

- BALE CHECK
- SILT FENCE
- DRAINAGE FLOW DIRECTON
- WETLAND

NOTE:  
ALL PROFILE INFO. BASED  
ON GRADING GRADE

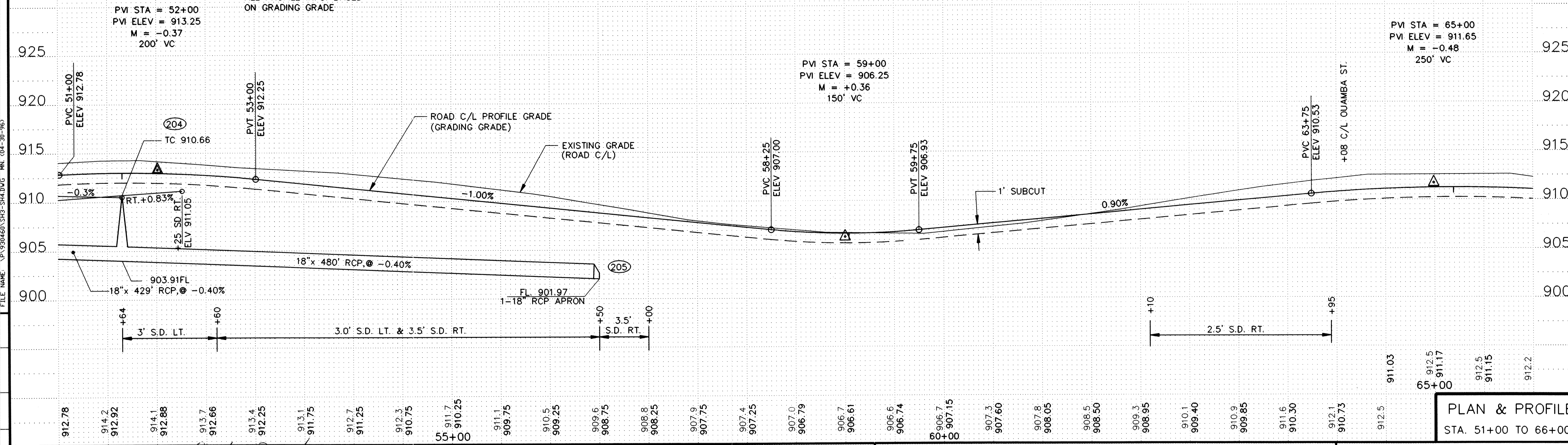

REVISIONS	DATE	BY

B.M. #10 ELEV. 909.37  
DBL SPIKE 10" OAK  
STA. 73+55, 60' LT.

B.M. #11 ELEV. 911.32  
TOP S.E. COR. STEP  
STA. 79+25, #2427 LT.

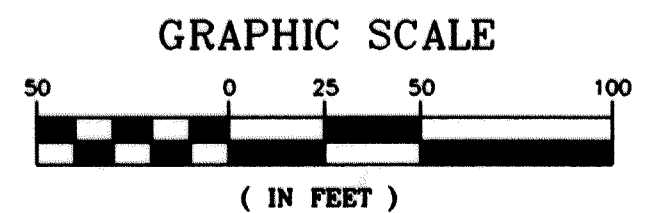
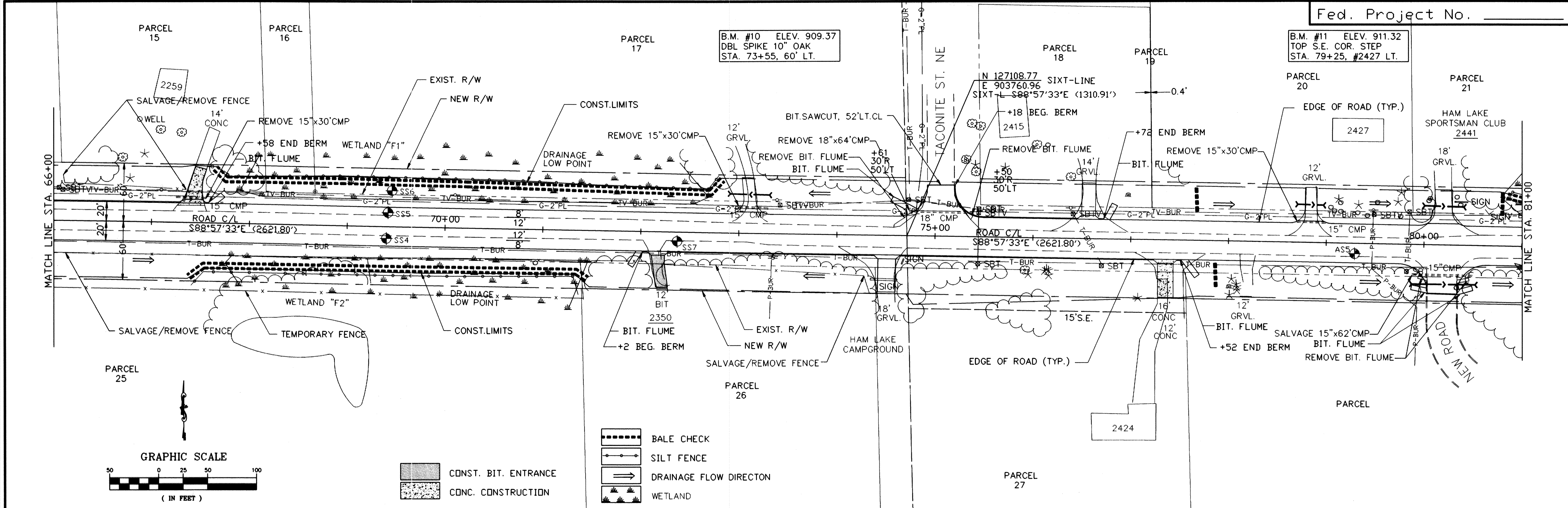

- BALE CHECK
- SILT FENCE
- DRAINAGE FLOW DIRECTION
- WETLAND
- CONST. BIT. ENTRANCE
- CONC. CONSTRUCTION

NOTE:  
ALL PROFILE INFO. BASED  
ON GRADING GRADE

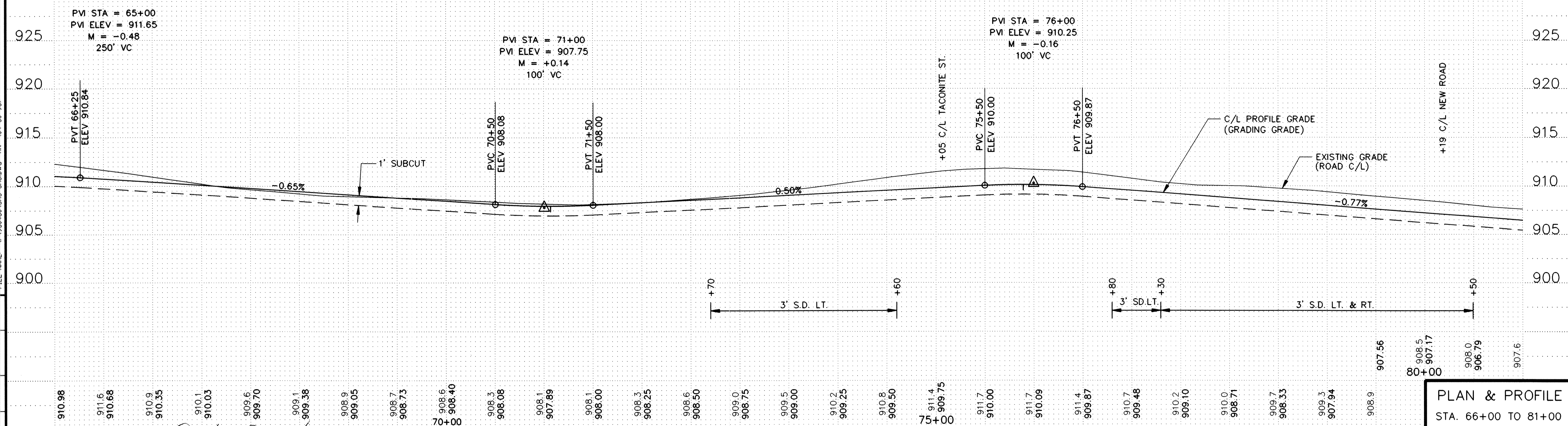

DATE	REVISIONS	BY

PLAN & PROFILE  
STA. 66+00 TO 81+00

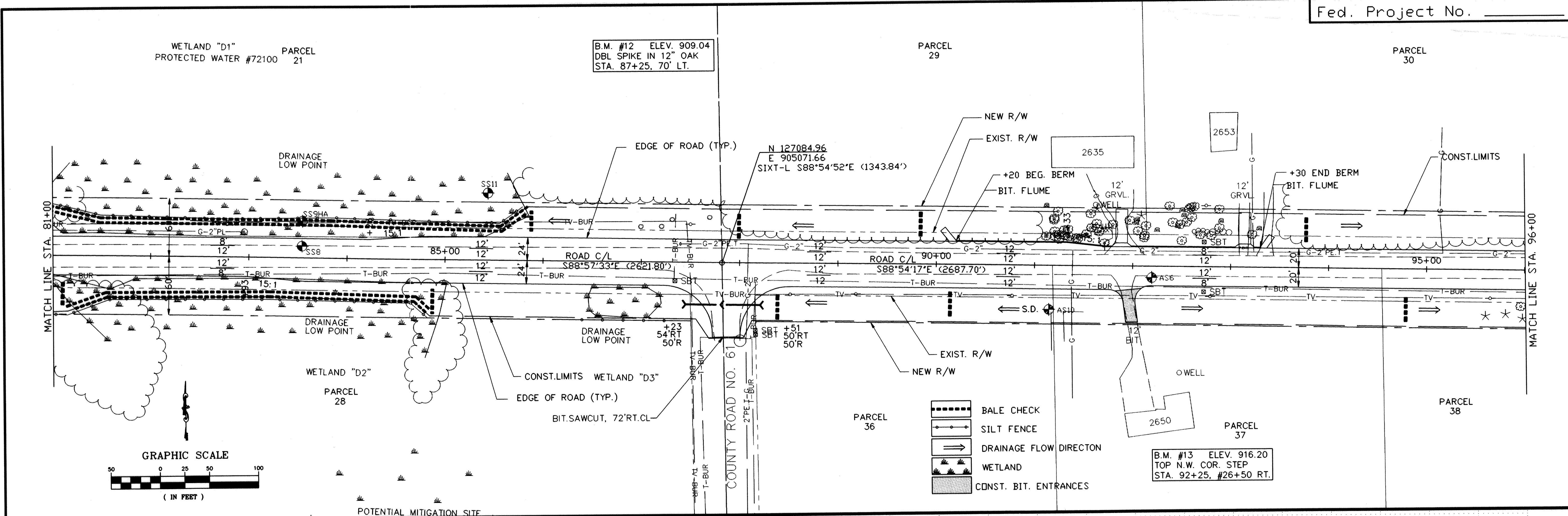

NOTE:  
ALL PROFILE INFO. BASED ON GRADING GRADE

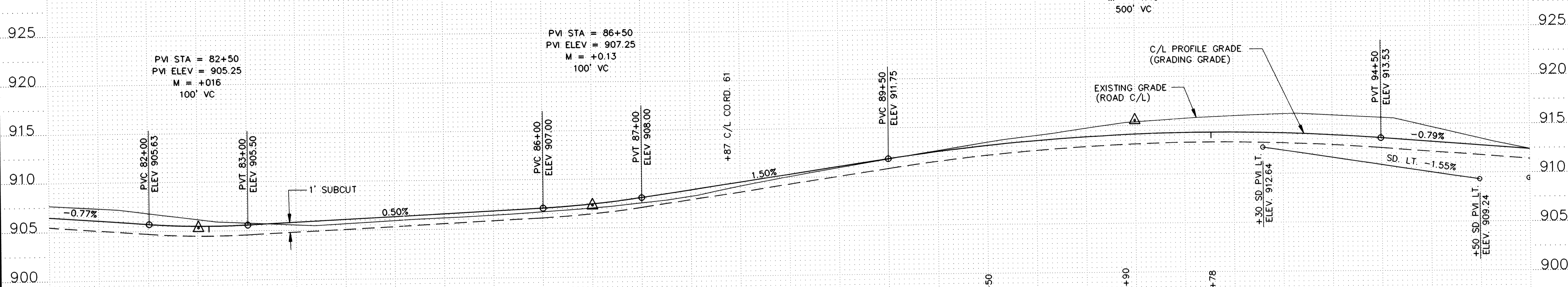

REVISIONS	DATE	BY

906.40	907.3	906.02	906.7	905.63	906.1	905.41	905.7	905.50	905.5	905.75	905.6	906.00	905.9	906.25	906.1	906.50	906.3	906.75	906.6	907.00	907.0	907.38	907.4	908.00	908.1	908.75	909.1	909.50	910.0	910.25	910.9	911.00	911.7	911.75	912.6	912.44	913.4	913.02	914.0	913.48	914.7	913.83	915.3	914.07	915.7	914.19	915.9	914.20	916.1	914.09	915.9	913.86	915.6	913.53	913.53	914.7	913.13	913.5	912.74	912.4
--------	-------	--------	-------	--------	-------	--------	-------	--------	-------	--------	-------	--------	-------	--------	-------	--------	-------	--------	-------	--------	-------	--------	-------	--------	-------	--------	-------	--------	-------	--------	-------	--------	-------	--------	-------	--------	-------	--------	-------	--------	-------	--------	-------	--------	-------	--------	-------	--------	-------	--------	-------	--------	-------	--------	--------	-------	--------	-------	--------	-------

PLAN & PROFILE  
STA. 81+00 TO 96+00

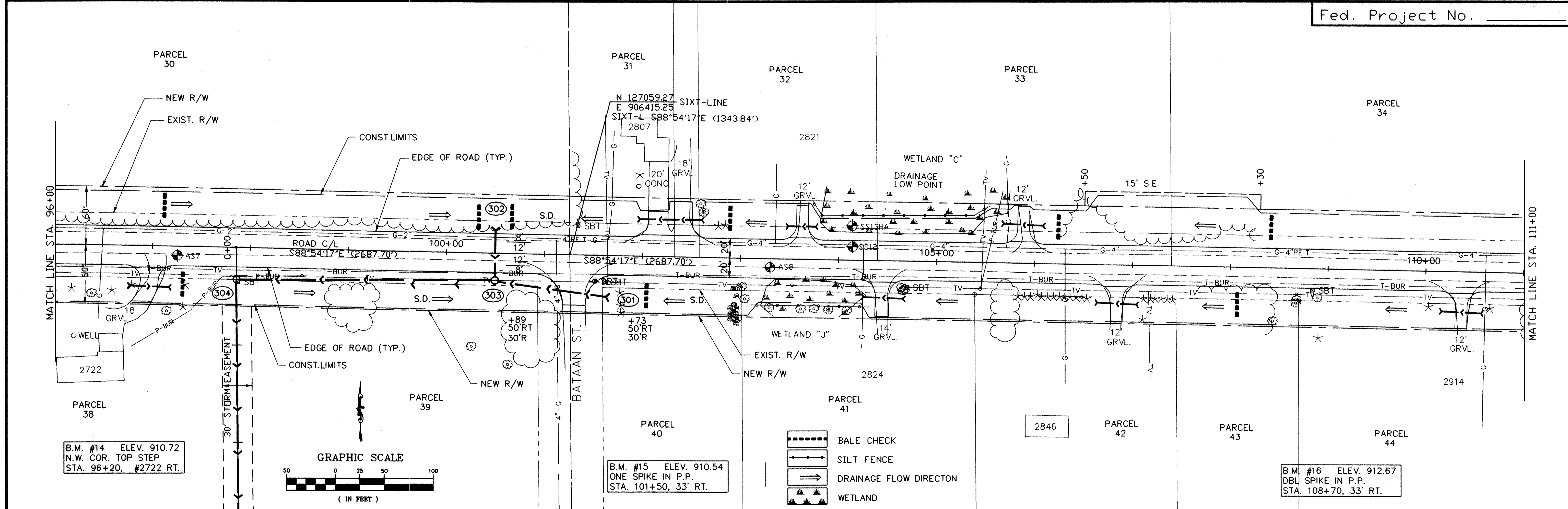

B.M. #14 ELEV. 910.72  
N.W. COR. TOP STEP  
STA. 96+20, #2722 RT.

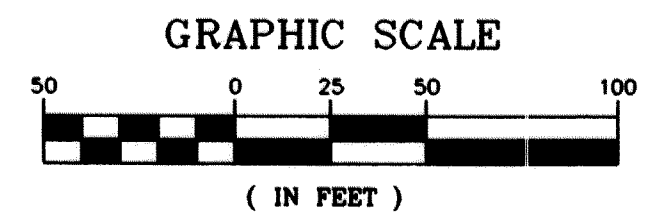

B.M. #15 ELEV. 910.54  
ONE SPIKE IN P.P.  
STA. 101+50, 33' RT.

- BALE CHECK
- SILT FENCE
- DRAINAGE FLOW DIRECTION
- WETLAND

B.M. #16 ELEV. 912.67  
DBL SPIKE IN P.P.  
STA. 108+70, 33' RT.

NOTE:  
ALL PROFILE INFO. BASED  
ON GRADING GRADE

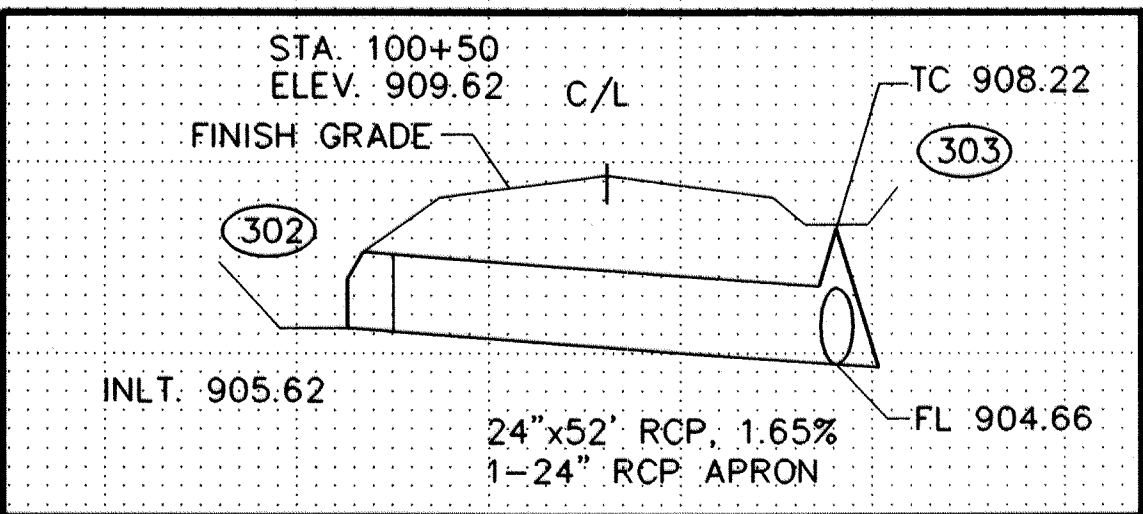

PVI STA = 101+50  
PVI ELEV = 908.00  
M = +0.79  
100' VC

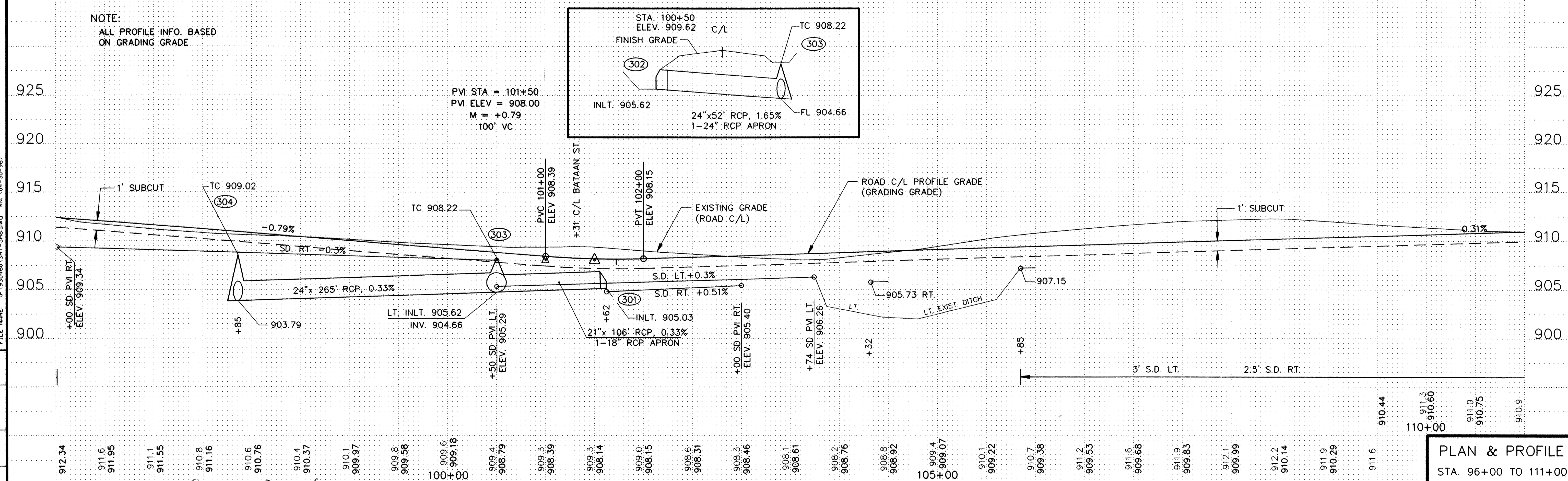

DATE	REVISIONS	BY

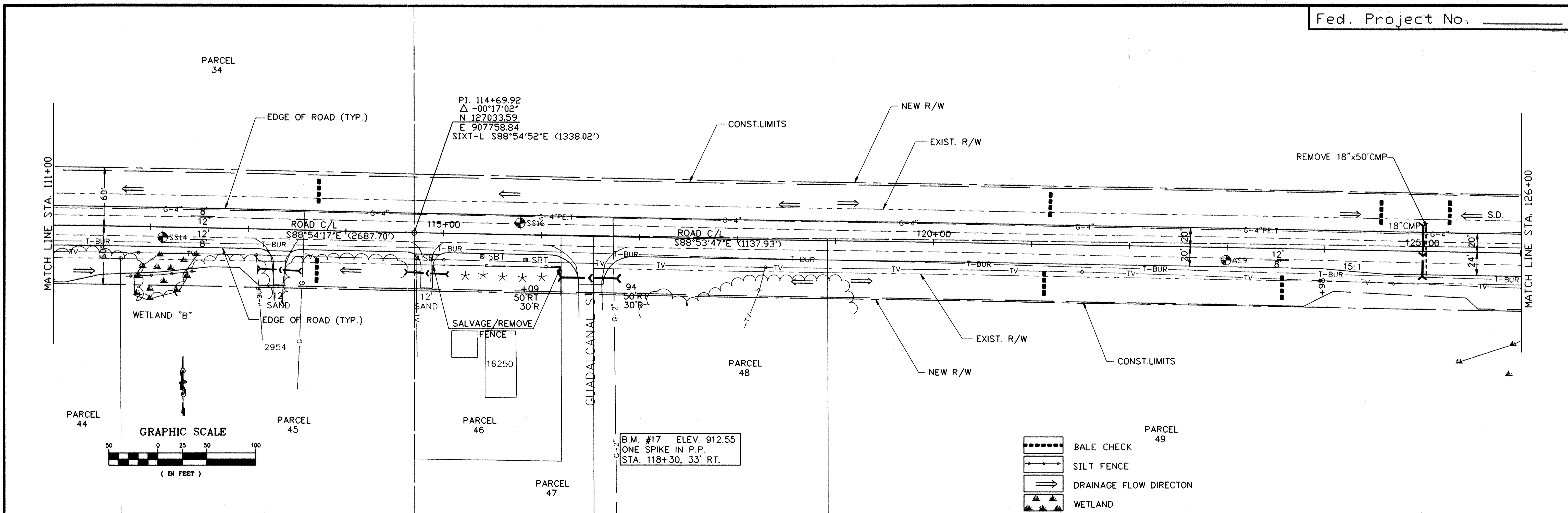

NOTE:  
ALL PROFILE INFO. BASED ON GRADING GRADE

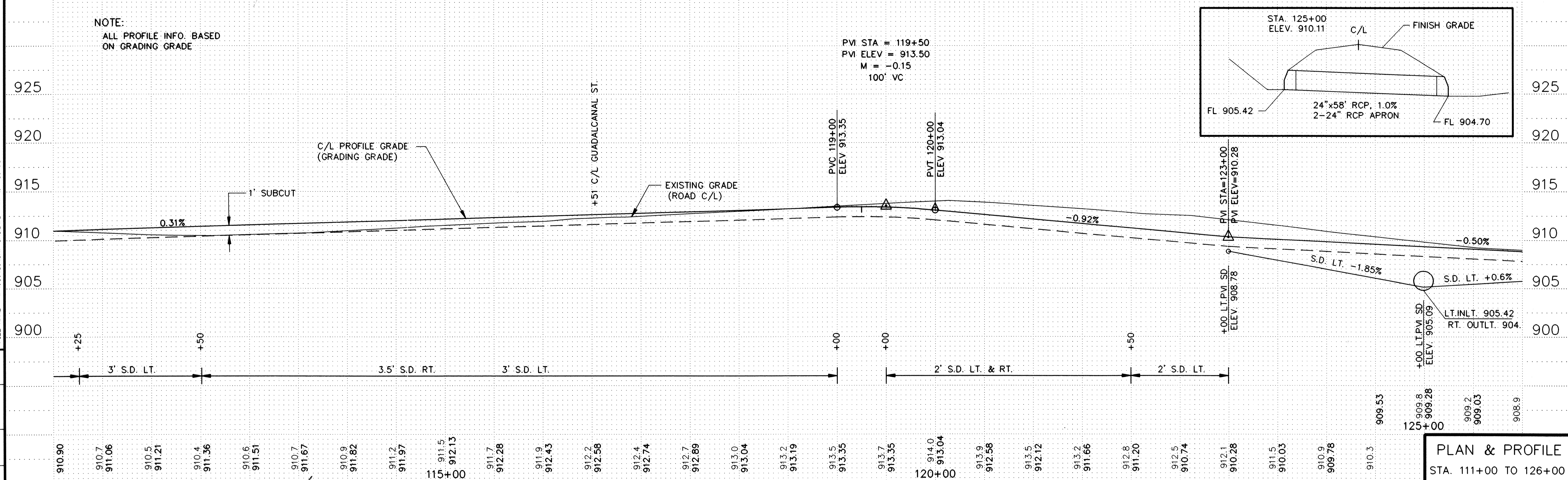

REVISIONS	DATE	BY

PLAN & PROFILE  
STA. 111+00 TO 126+00



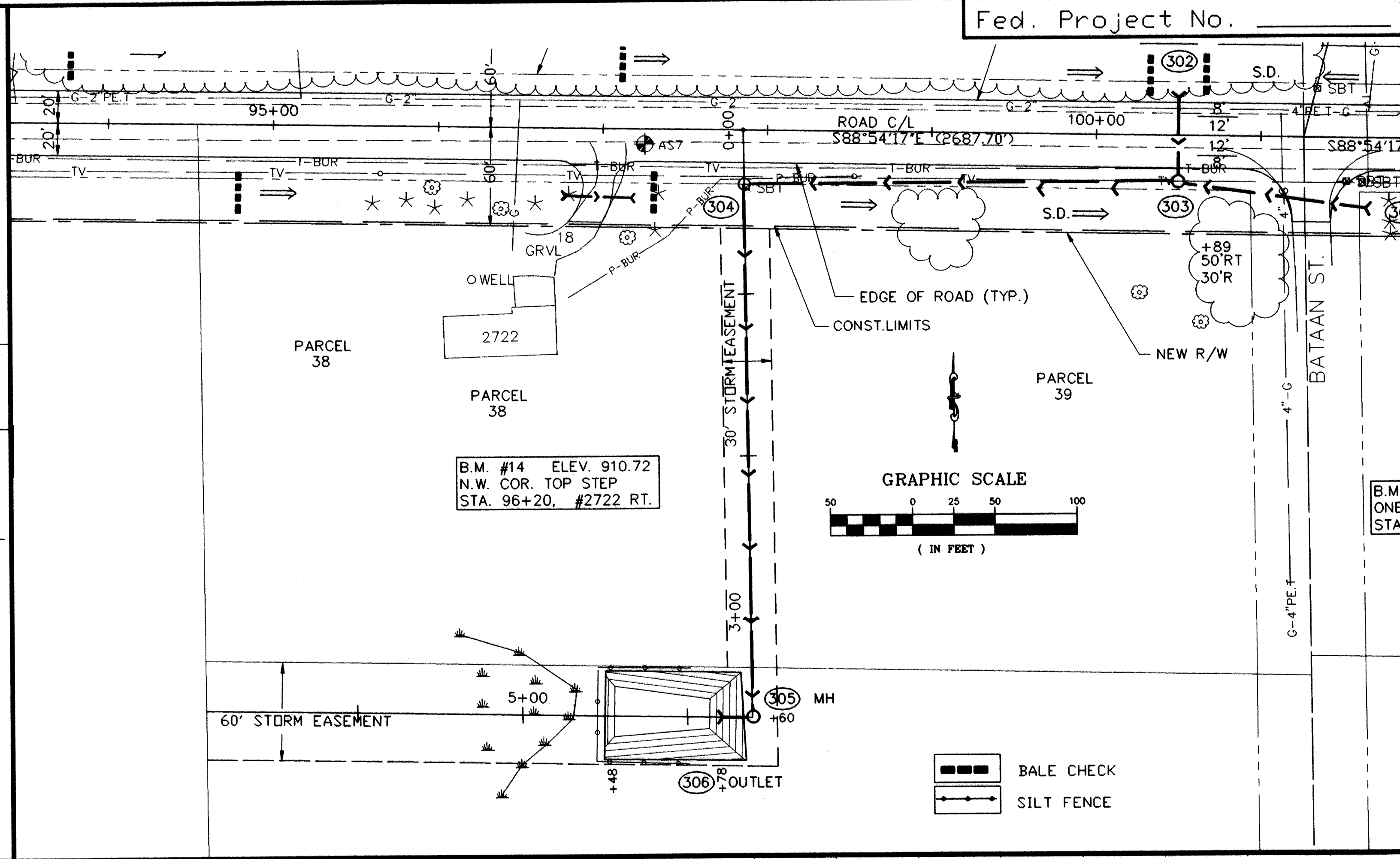
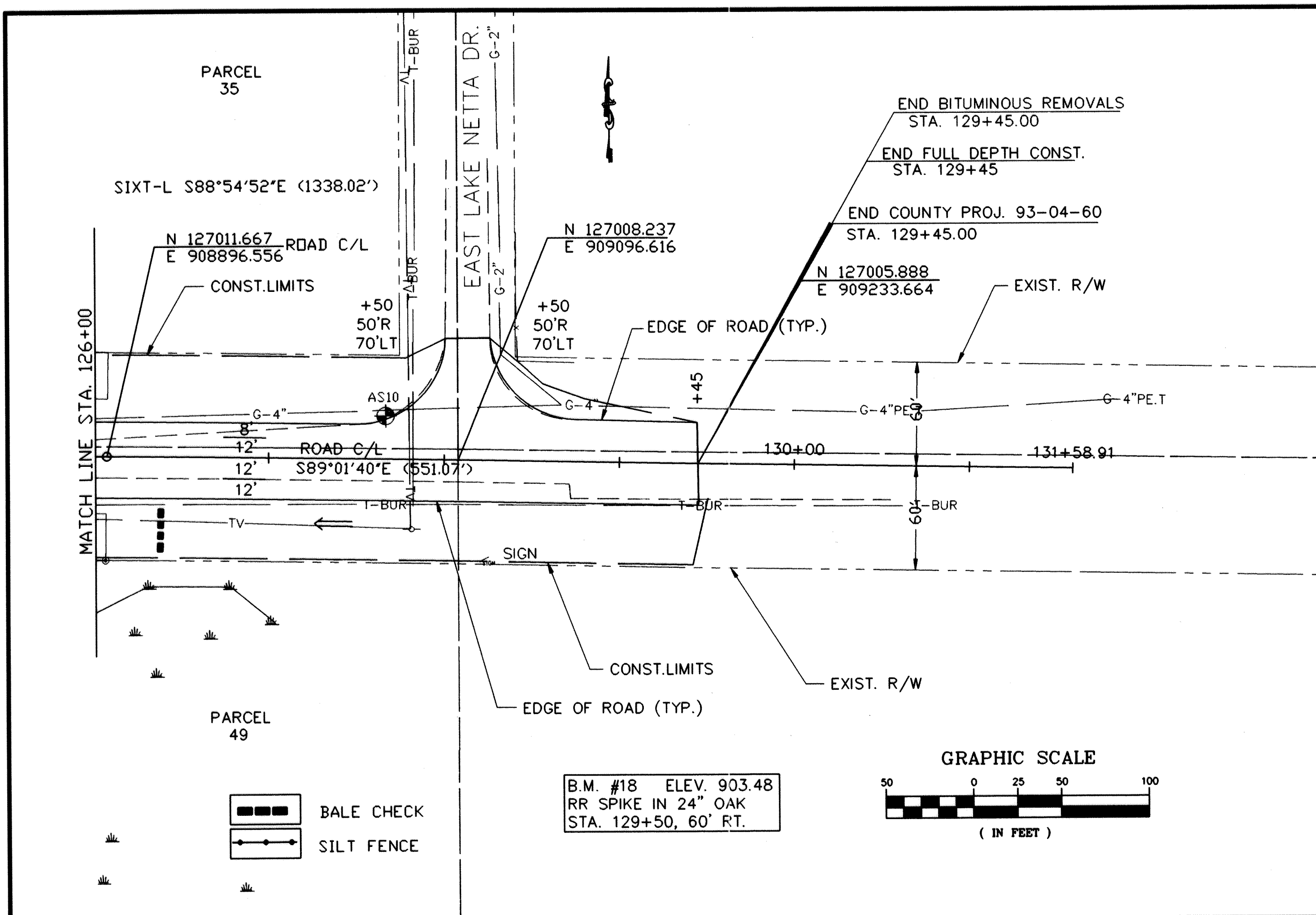

NOTE:  
ALL PROFILE INFO. BASED  
ON GRADING GRADE

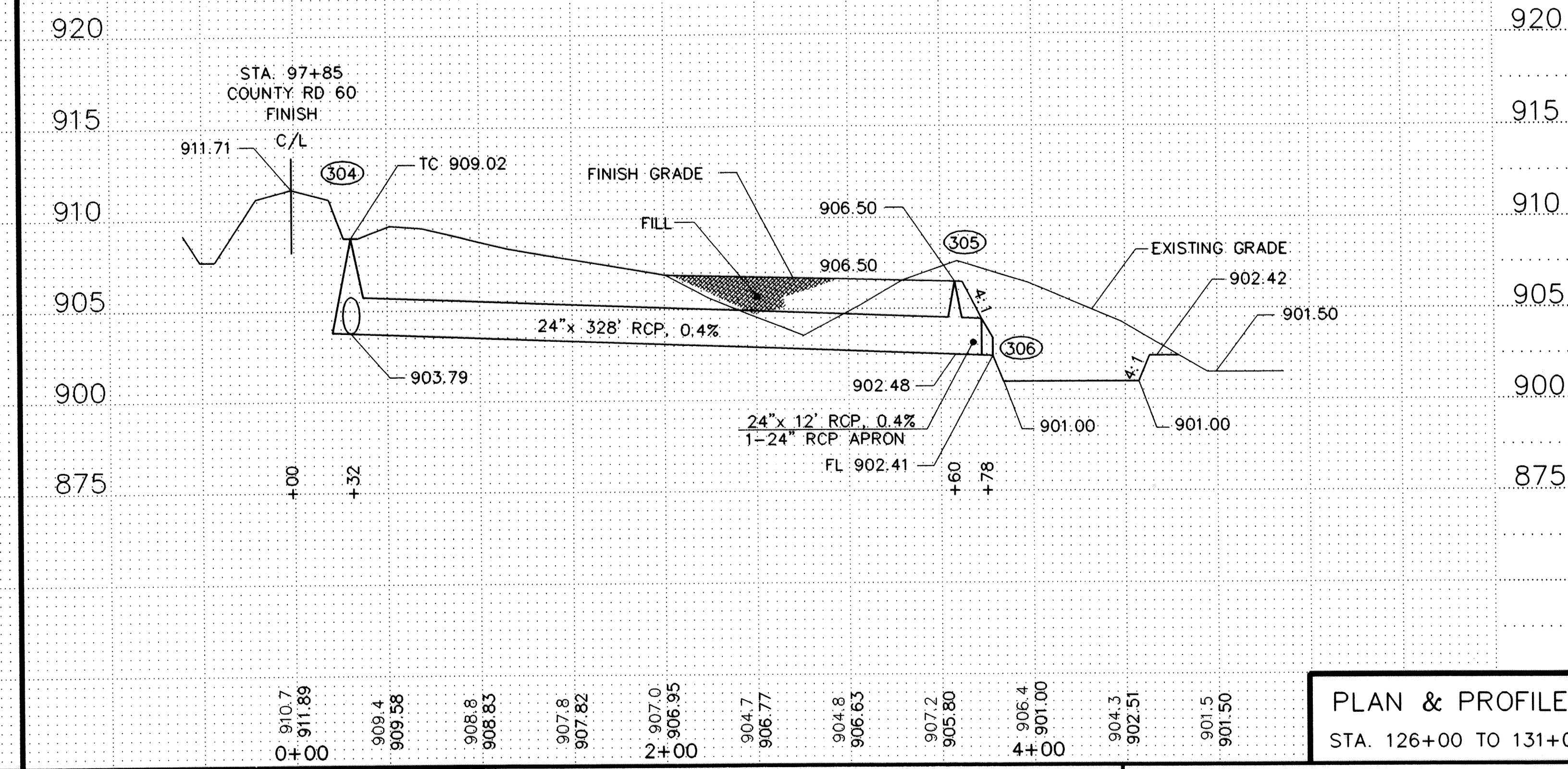
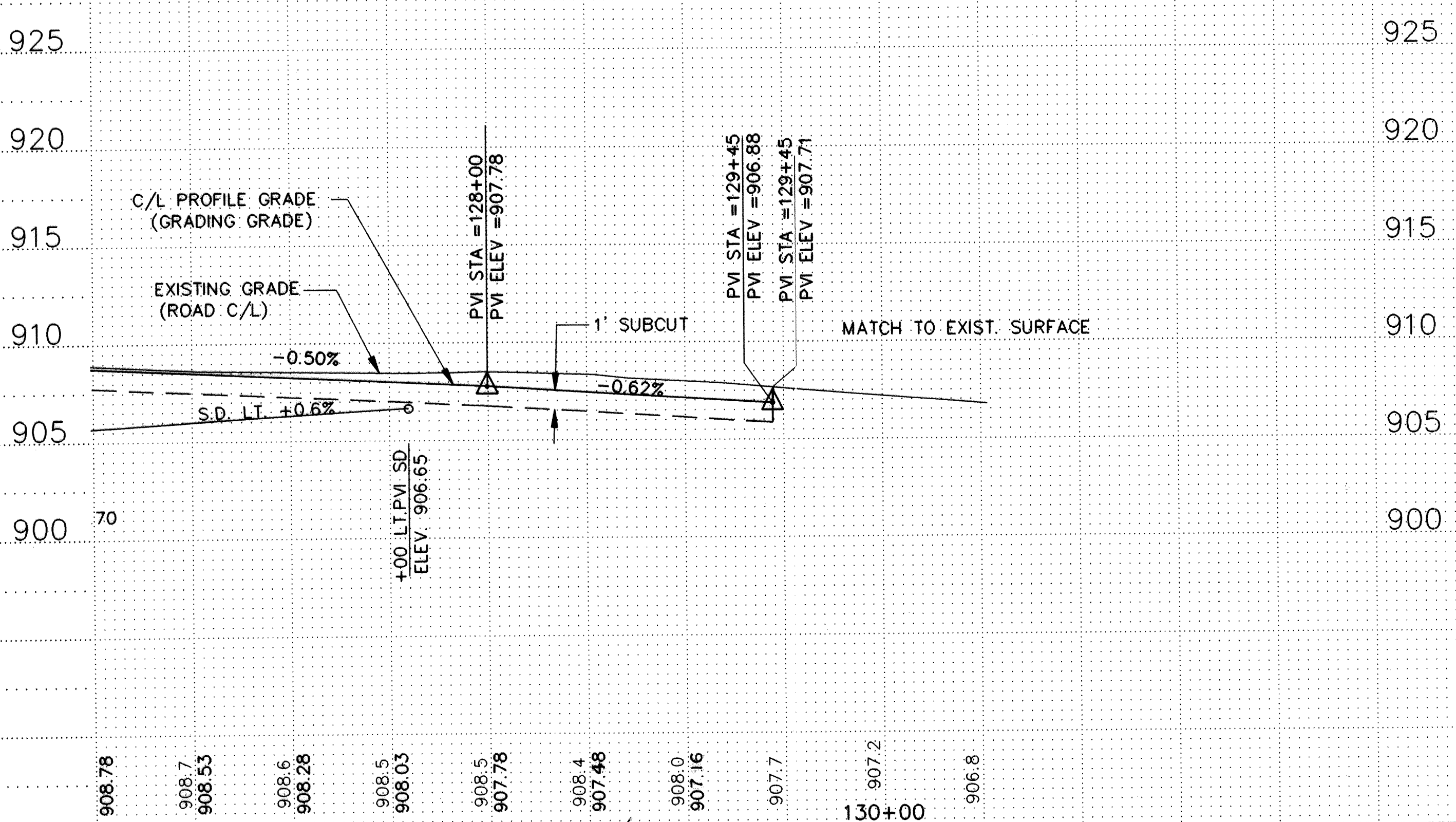

DATE	REVISIONS	BY	DATE	BY

**EXCAVATION EMBANKMENT**  
 SUB-TOTALS CU.YDS. SUB-TOTALS CU.YDS.

Fed. Proj. No.

**EXCAVATION EMBANKMENT**  
 SUB-TOTALS CU.YDS. SUB-TOTALS CU.YDS.

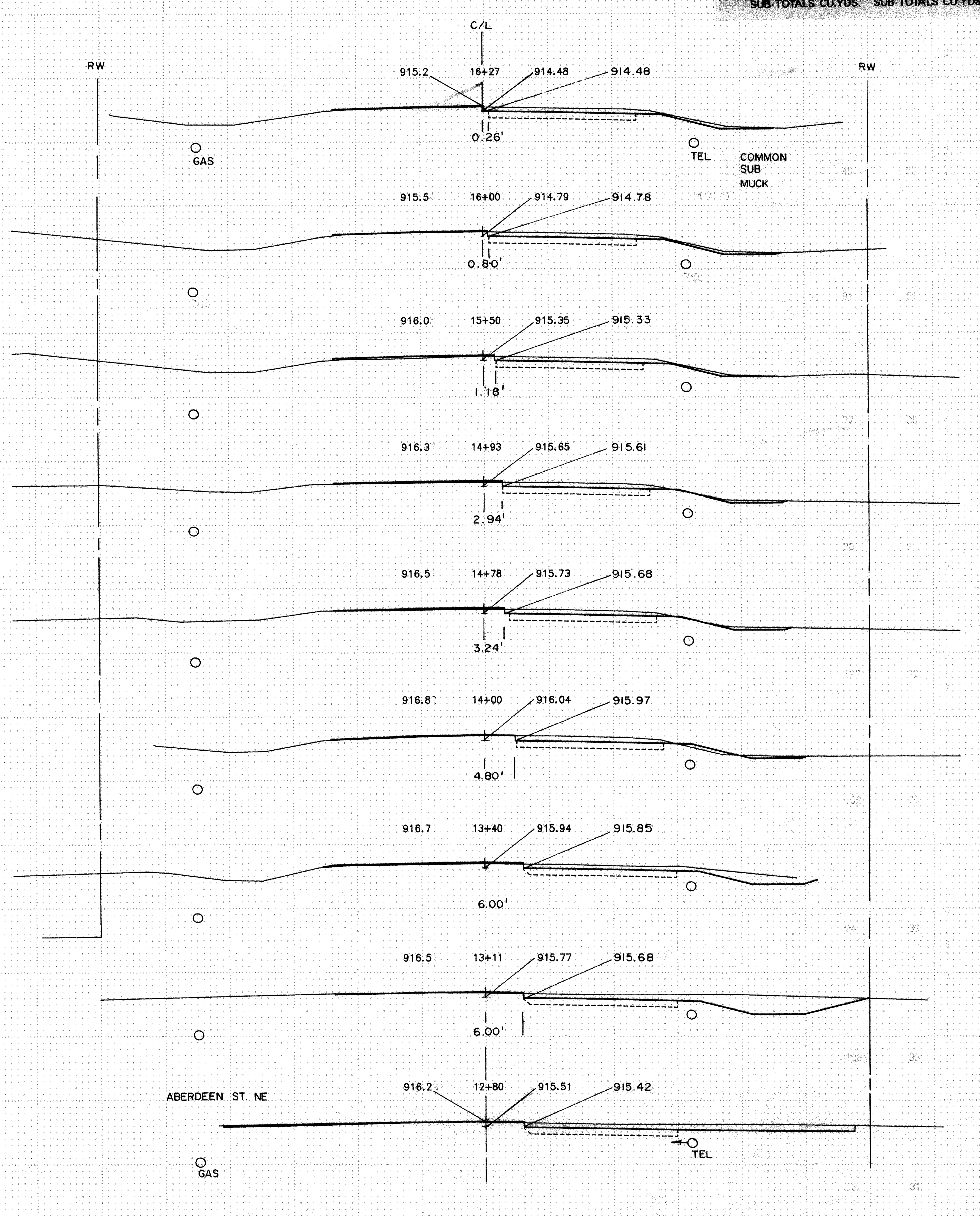
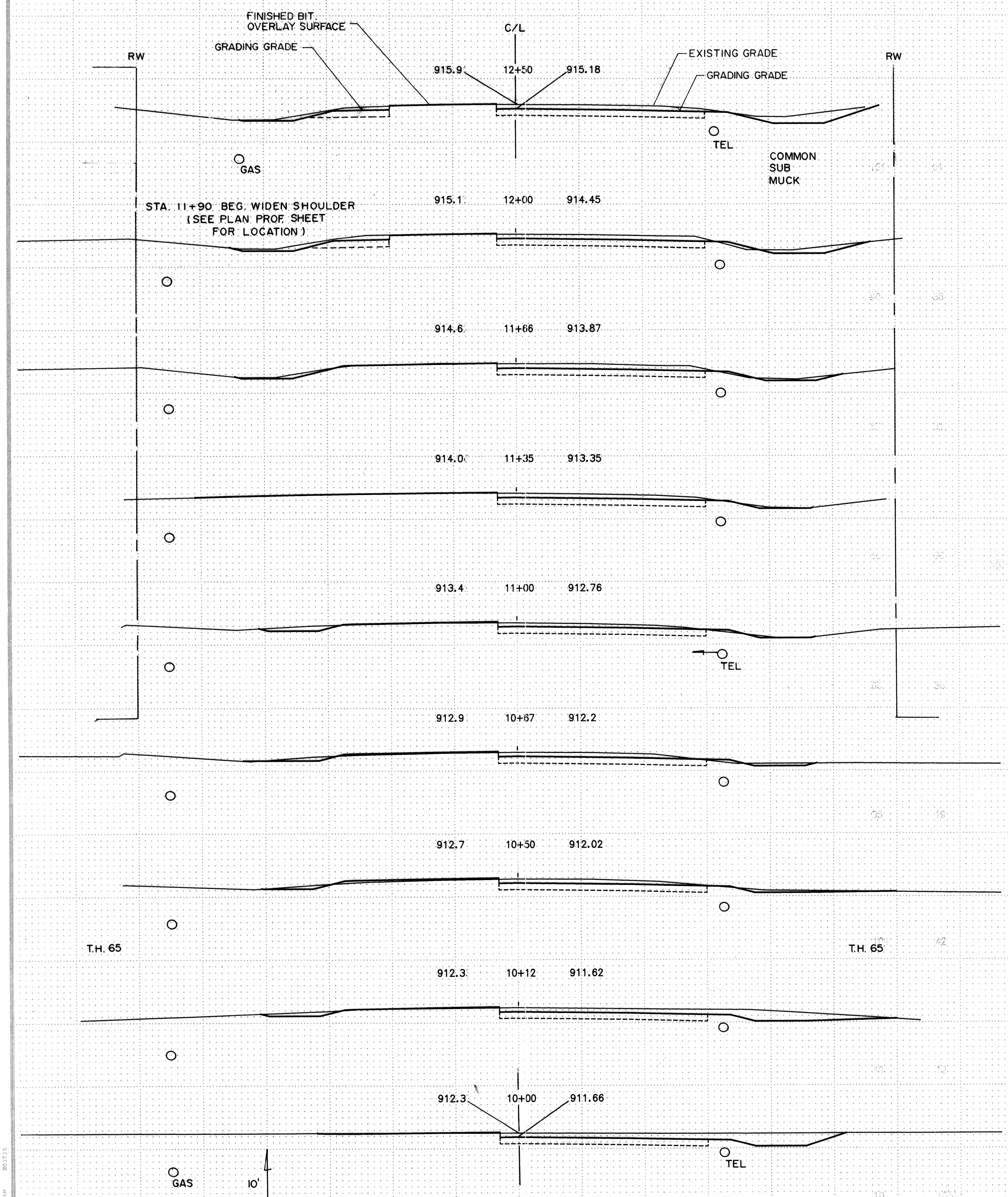

**EXCAVATION EMBANKMENT**  
SUB-TOTALS CU.YDS. SUB-TOTALS CU.YDS.

Fed. Proj. No.

**EXCAVATION EMBANKMENT**  
SUB-TOTALS CU.YDS. SUB-TOTALS CU.YDS.

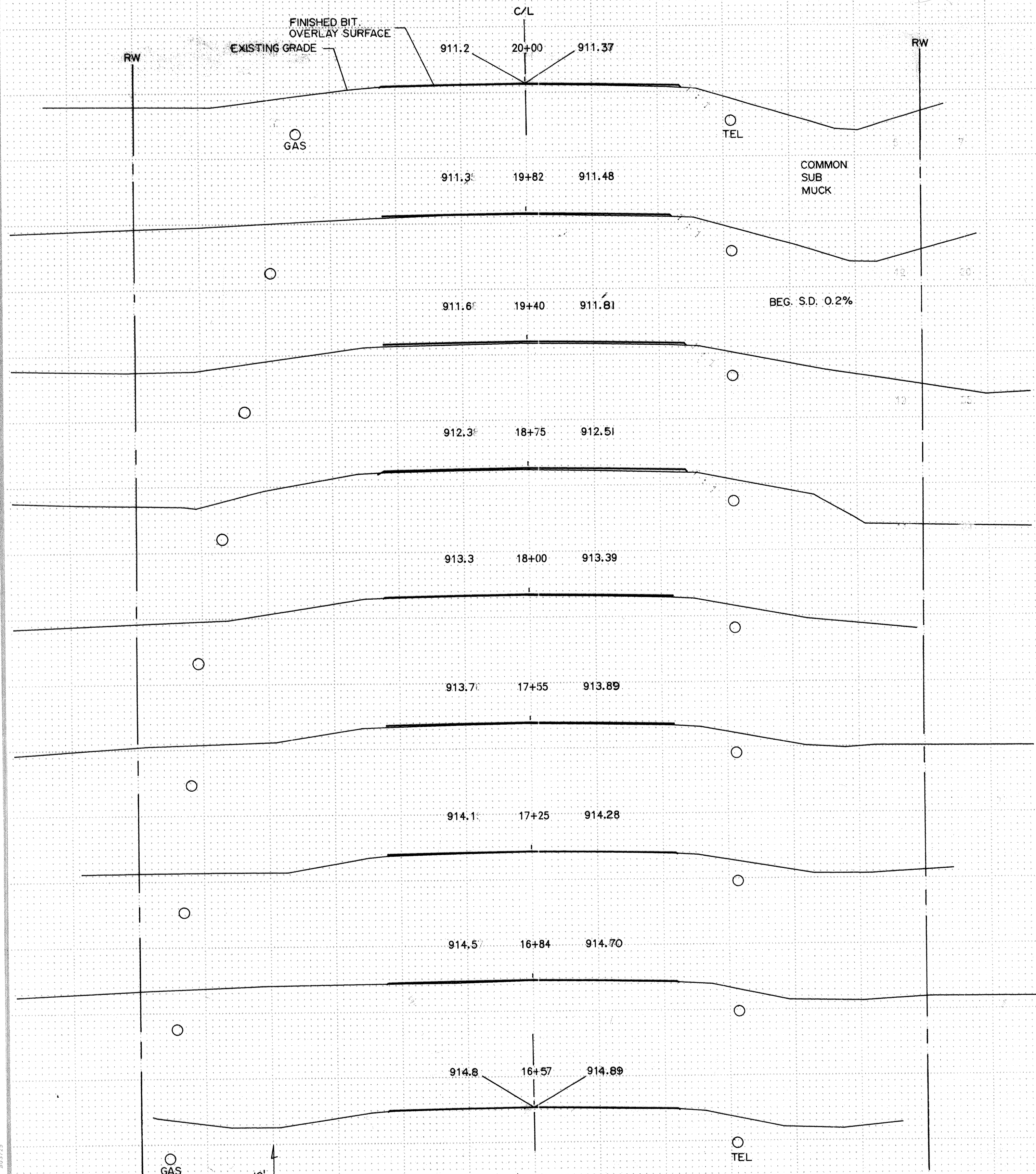

NOTE:  
UTILITY ELEVATIONS ASSUMED  
NOT ACTUAL

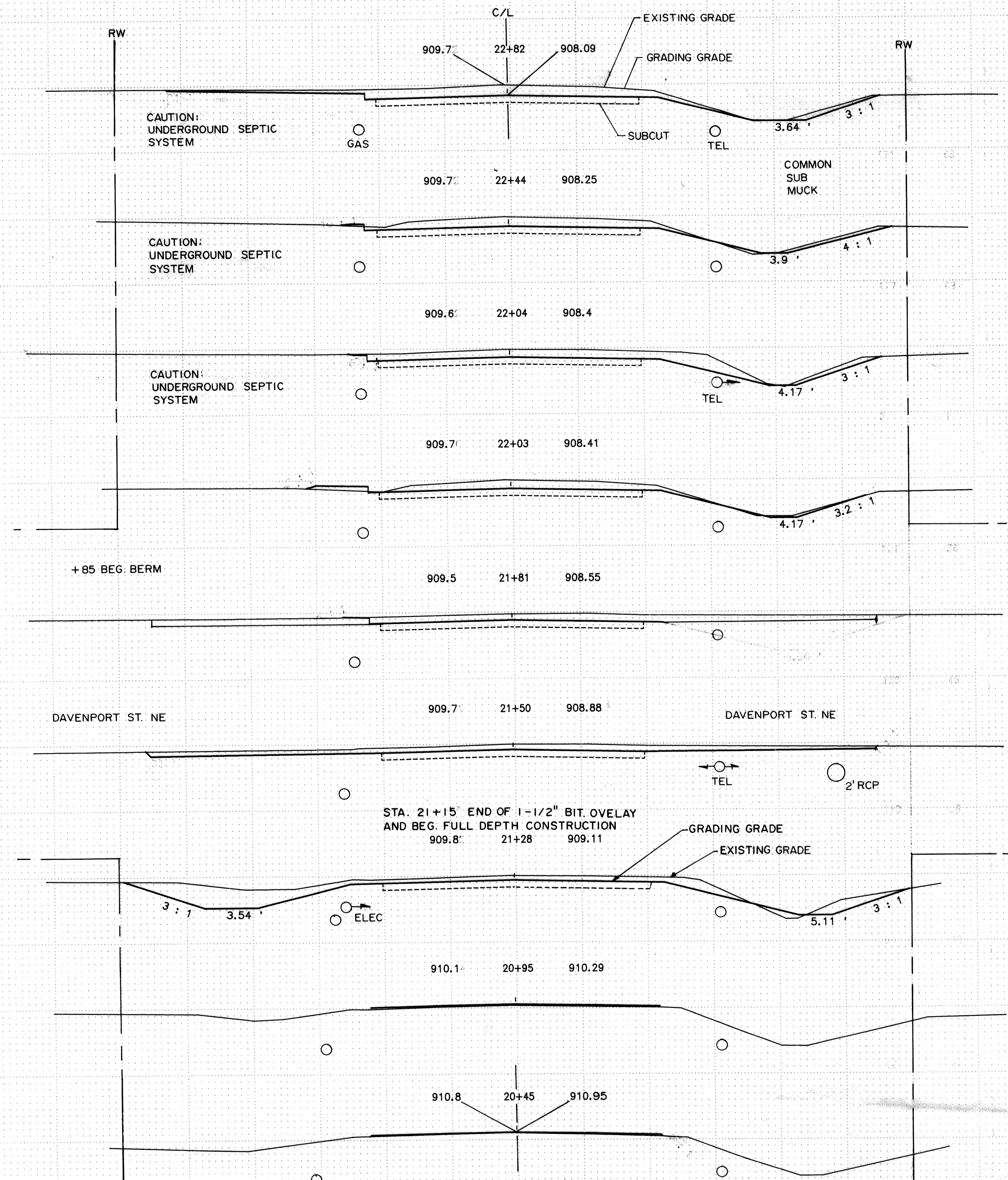

CROSS SECTIONS  
STA. 16+27 TO STA. 22+82

Co. Proj. No. 93-04-60

Sheet No. 27 of 42 Sheets

Copy Equipment Form # 14 303723

**EXCAVATION EMBANKMENT**  
 SUB-TOTALS CU.YDS. SUB-TOTALS CU.YDS.

Fed. Proj. No.

**EXCAVATION EMBANKMENT**  
 SUB-TOTALS CU.YDS. SUB-TOTALS CU.YDS.

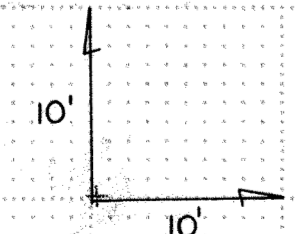
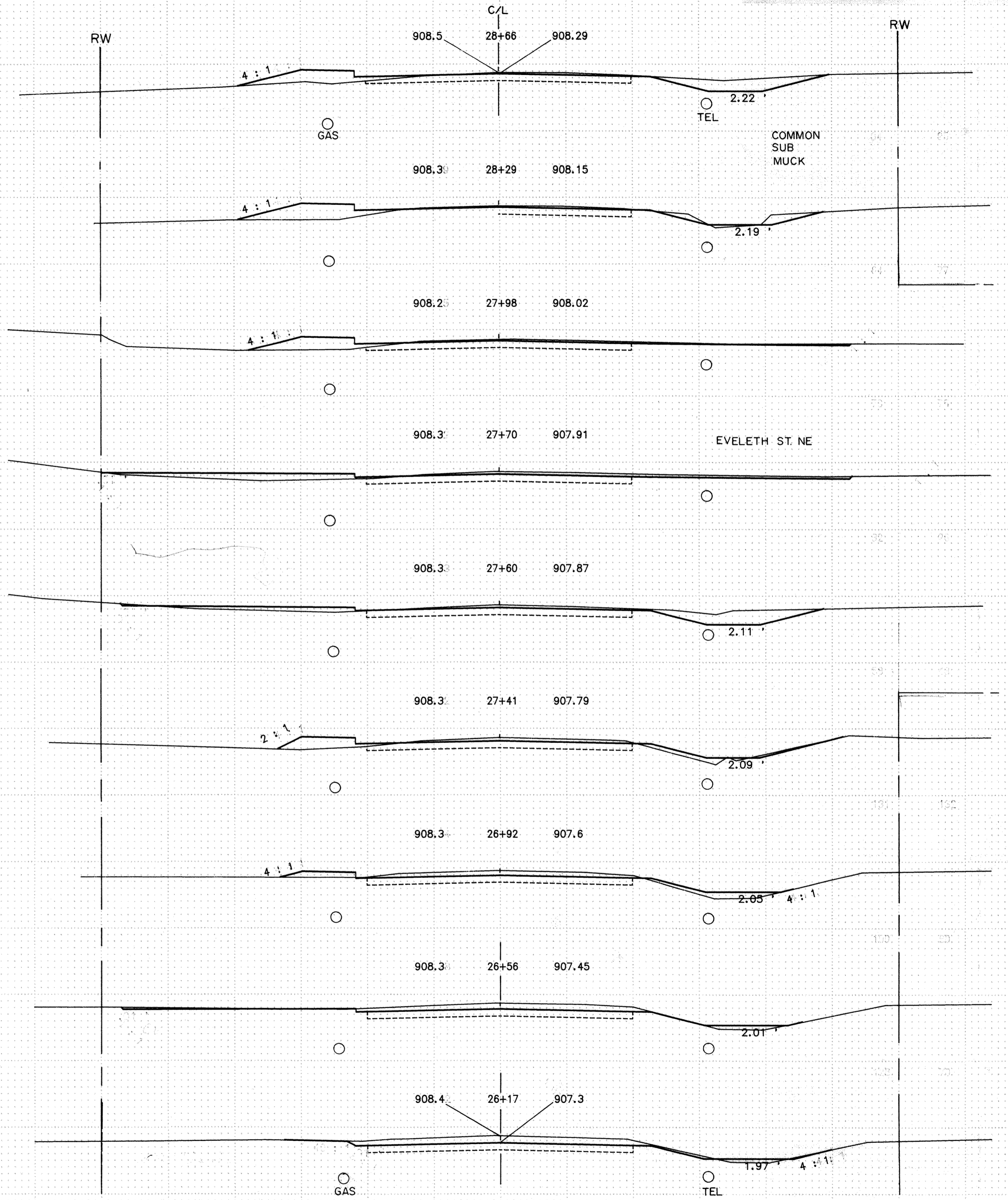
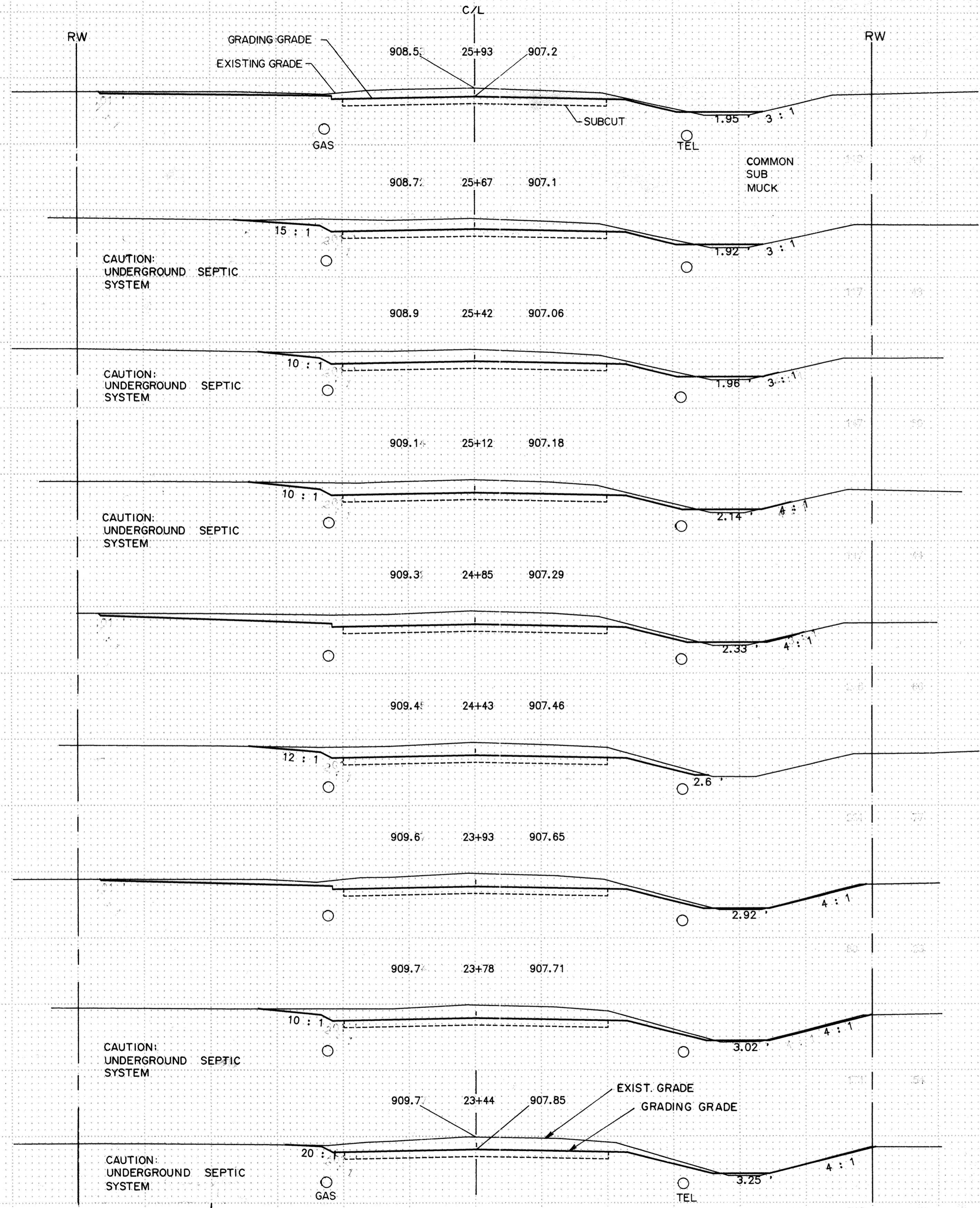

NOTE:  
 UTILITY ELEVATIONS ASSUMED  
 NOT ACTUAL

**EXCAVATION EMBANKMENT**  
SUB-TOTALS CU.YDS. SUB-TOTALS CU.YDS.

Fed. Proj. No.  
**EXCAVATION EMBANKMENT**  
SUB-TOTALS CU.YDS. SUB-TOTALS CU.YDS.

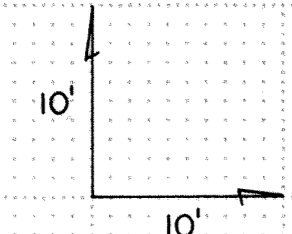
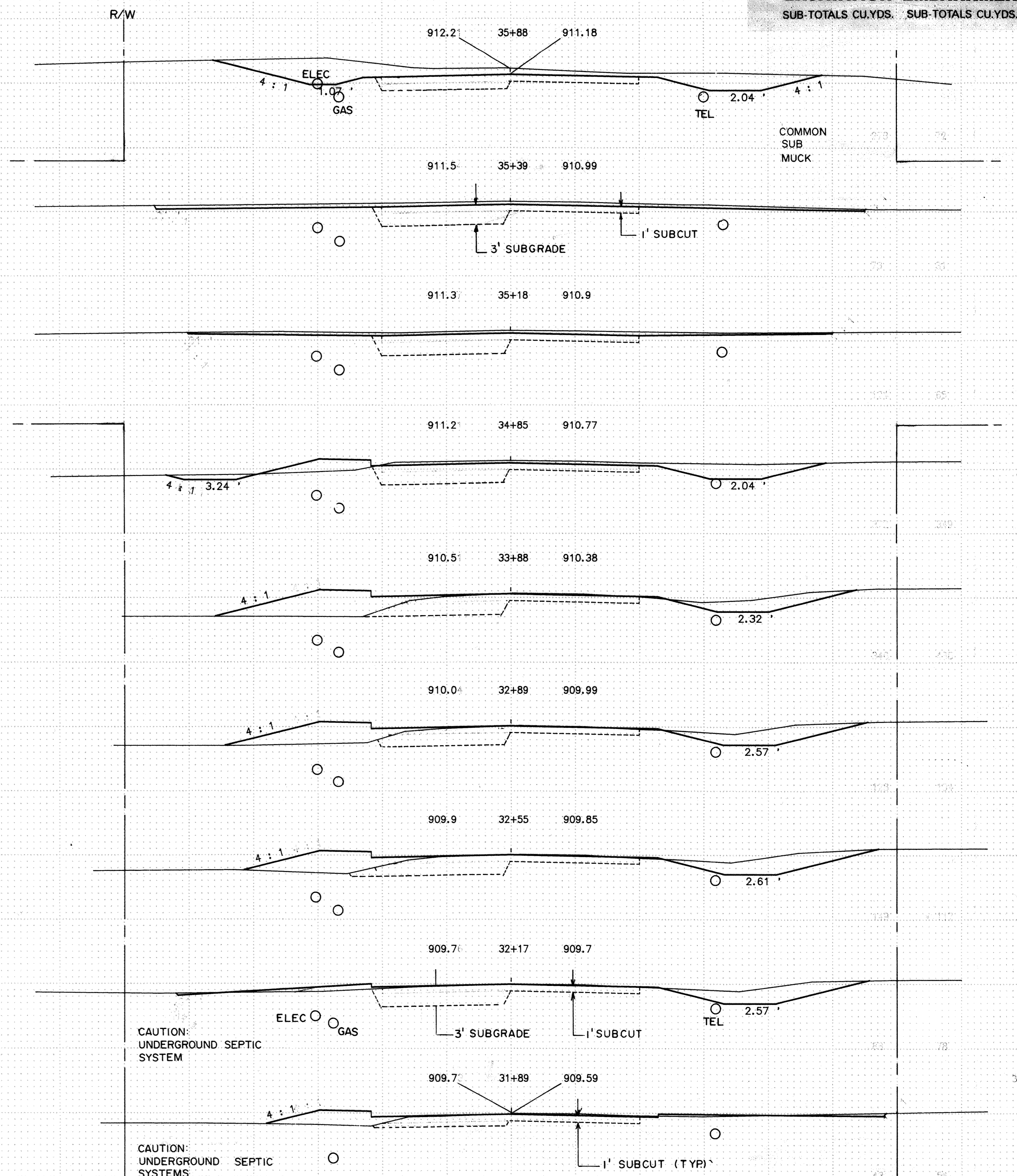
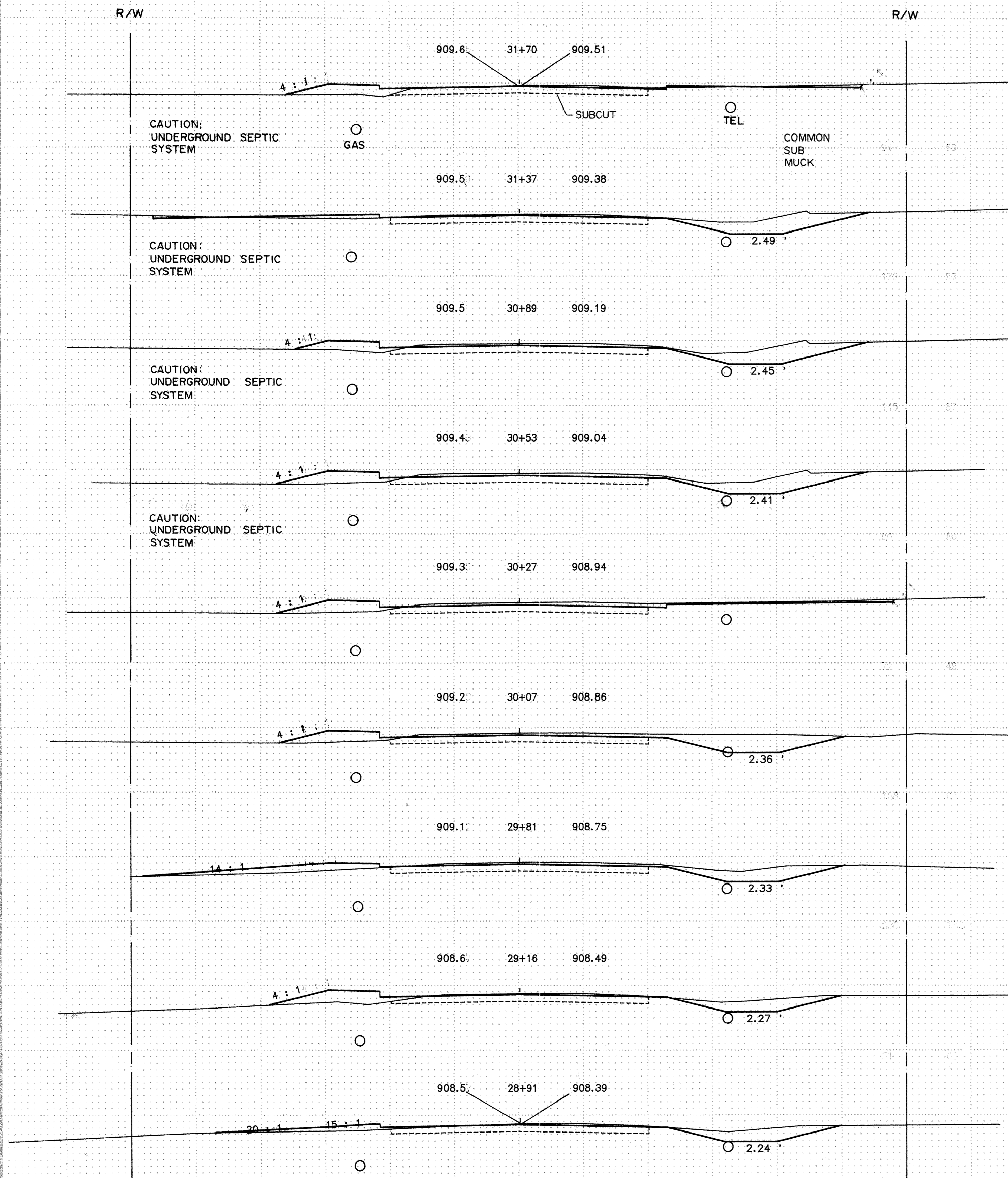

NOTE:  
UTILITY ELEVATIONS ASSUMED  
NOT ACTUAL

CROSS-SECTIONS  
STA. 28+91 TO STA. 35+88

**EXCAVATION EMBANKMENT**

SUB-TOTALS CU.YDS. SUB-TOTALS CU.YDS.

Fed. Proj. No.

**EXCAVATION EMBANKMENT**

SUB-TOTALS CU.YDS. SUB-TOTALS CU.YDS.

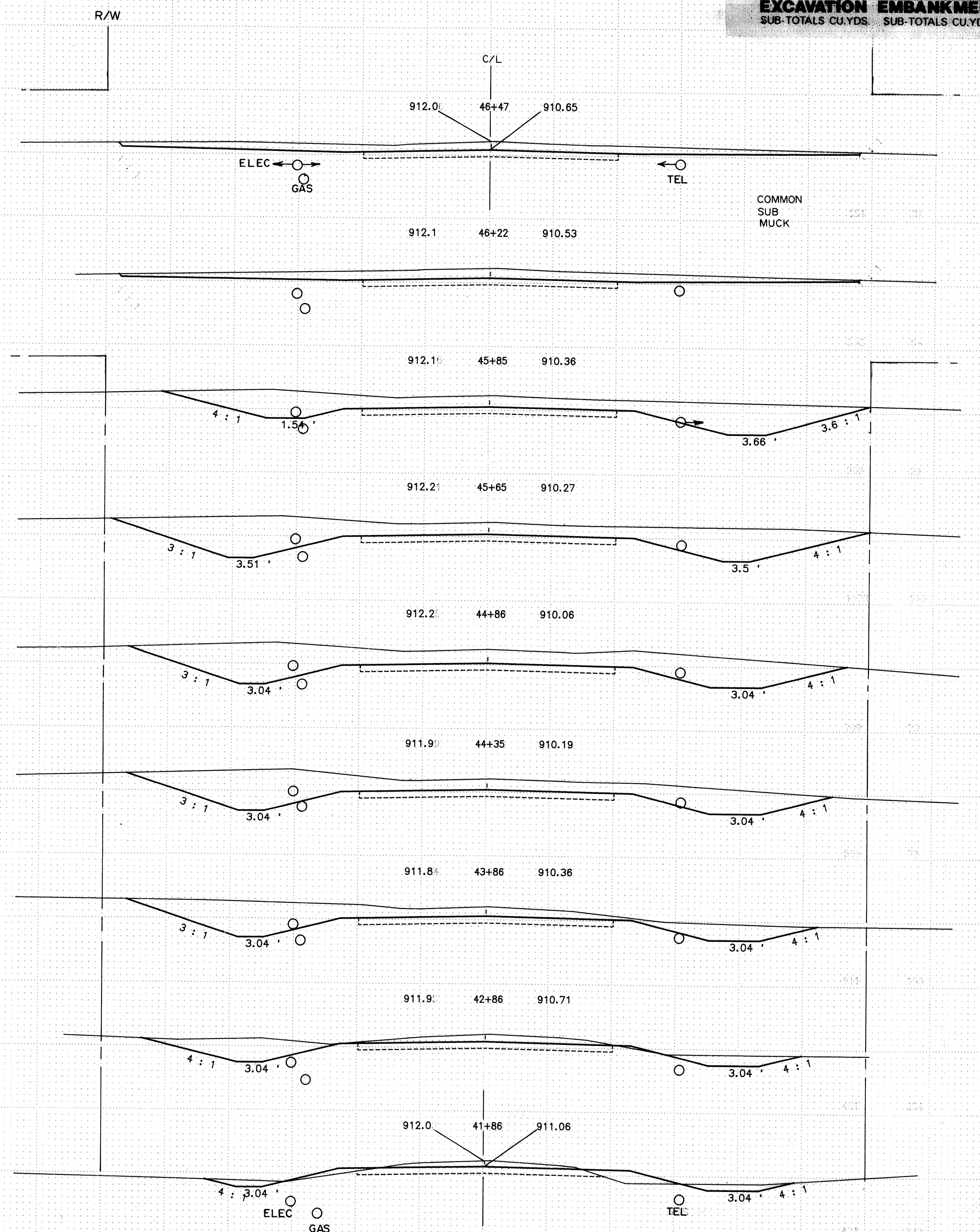
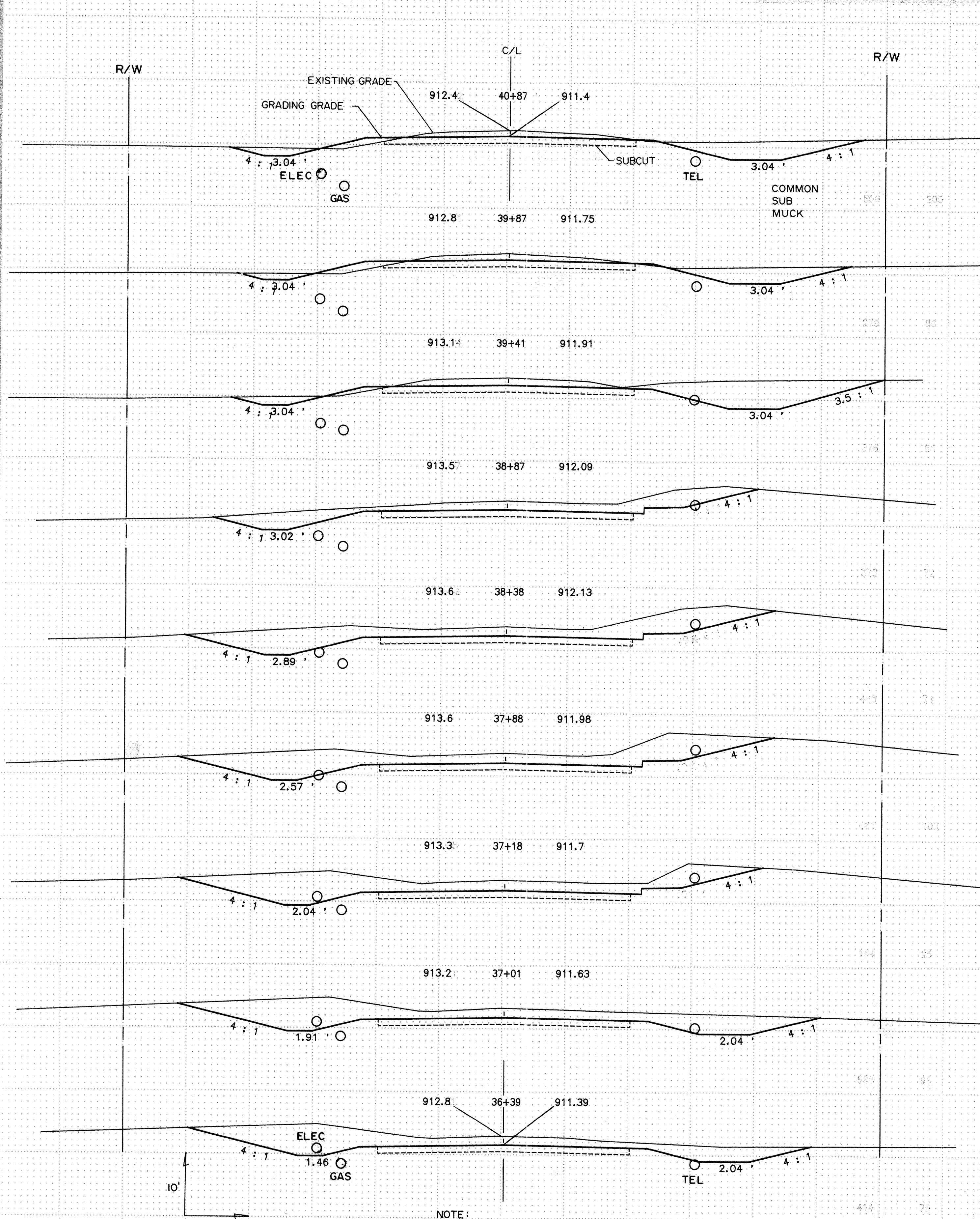

NOTE:  
UTILITY ELEVATIONS  
NOT ACTUAL ASSUMED

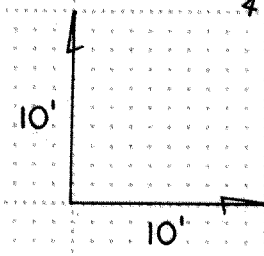

CROSS-SECTIONS  
STA. 36+39 TO STA. 46+47

**EXCAVATION EMBANKMENT**  
SUB-TOTALS CU.YDS. SUB-TOTALS CU.YDS.

Fed. Proj. No.

**EXCAVATION EMBANKMENT**  
SUB-TOTALS CU.YDS. SUB-TOTALS CU.YDS.

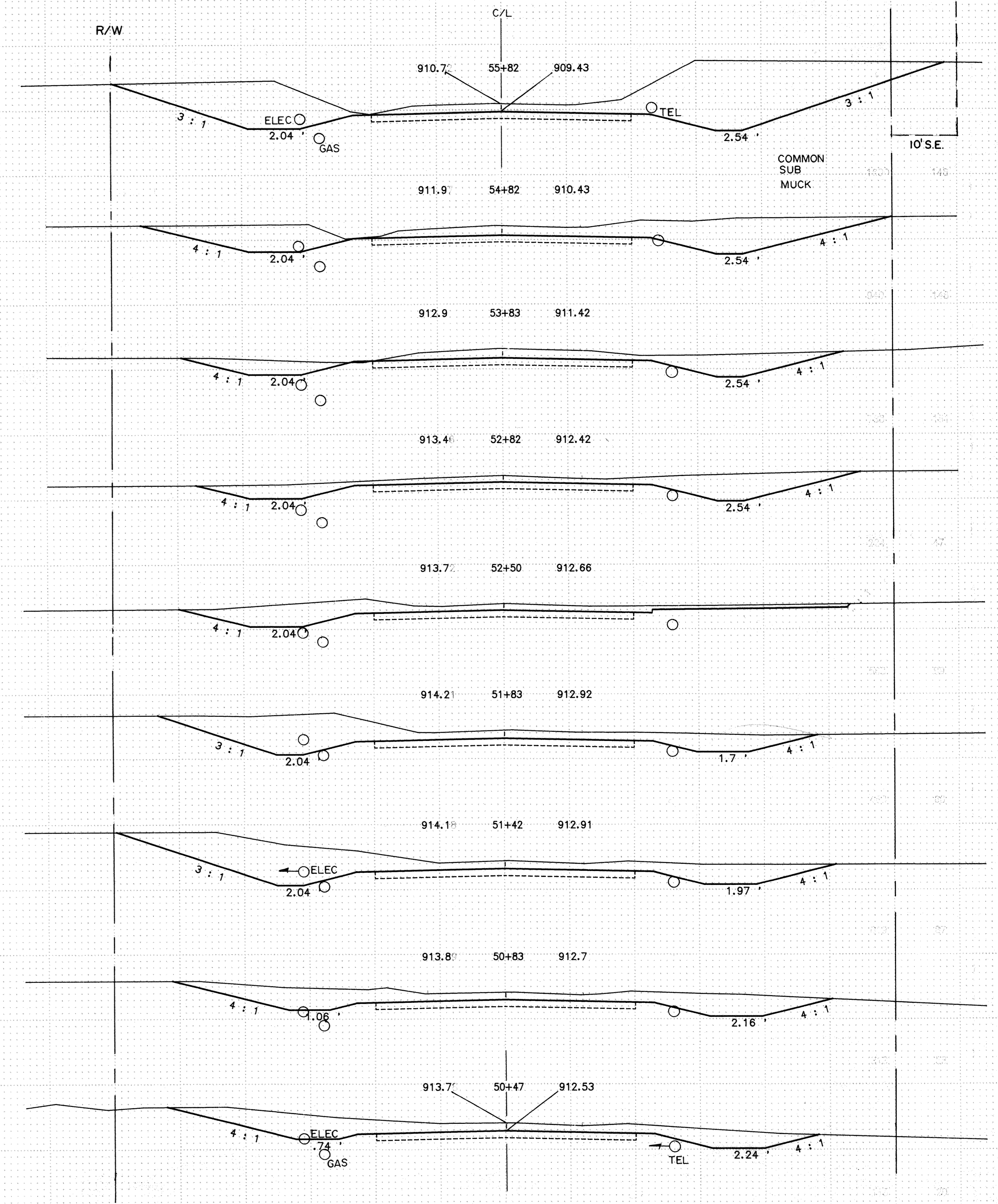
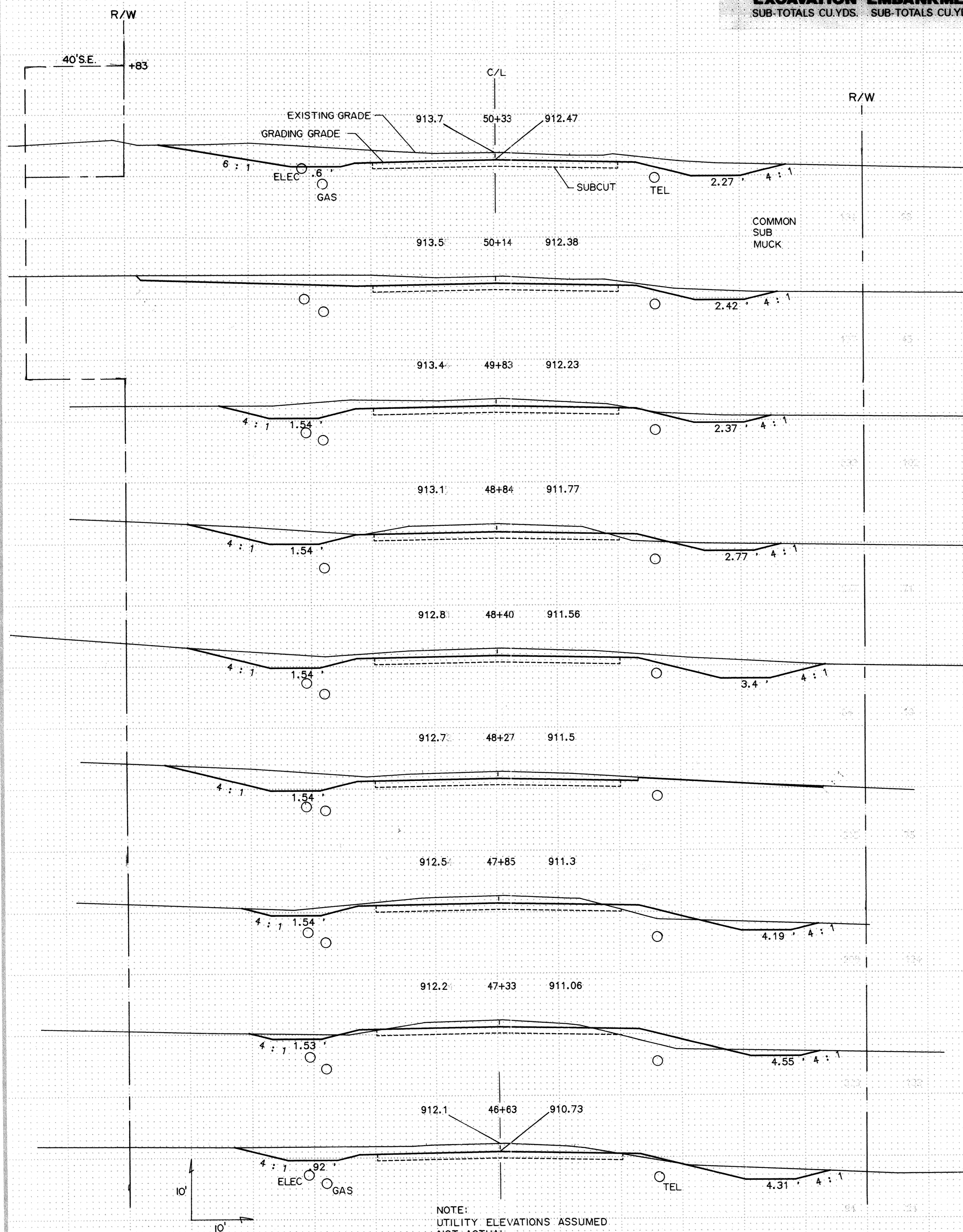

NOTE:  
UTILITY ELEVATIONS ASSUMED  
NOT ACTUAL

CROSS-SECTIONS  
STA. 46+63 TO STA. 55+82

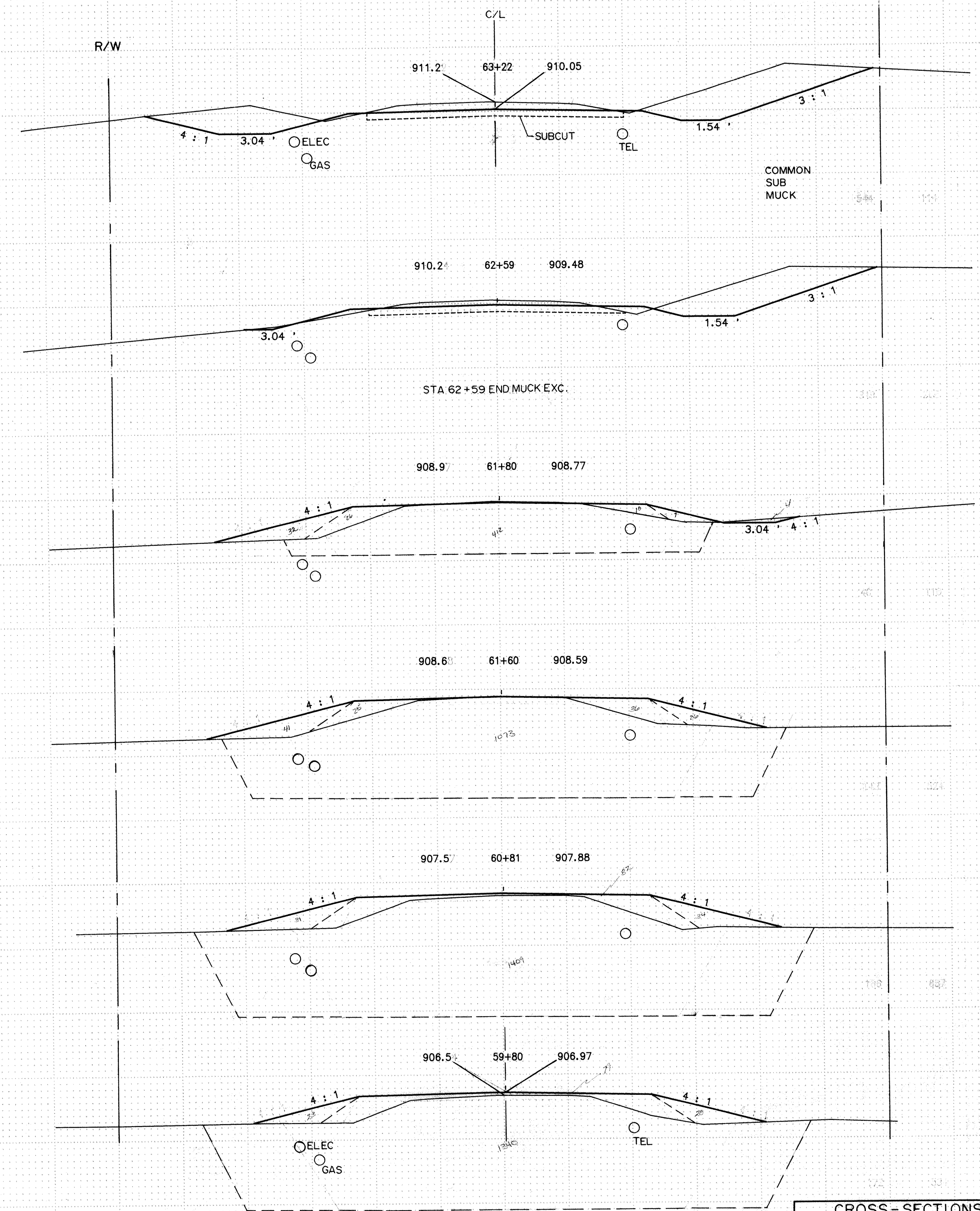
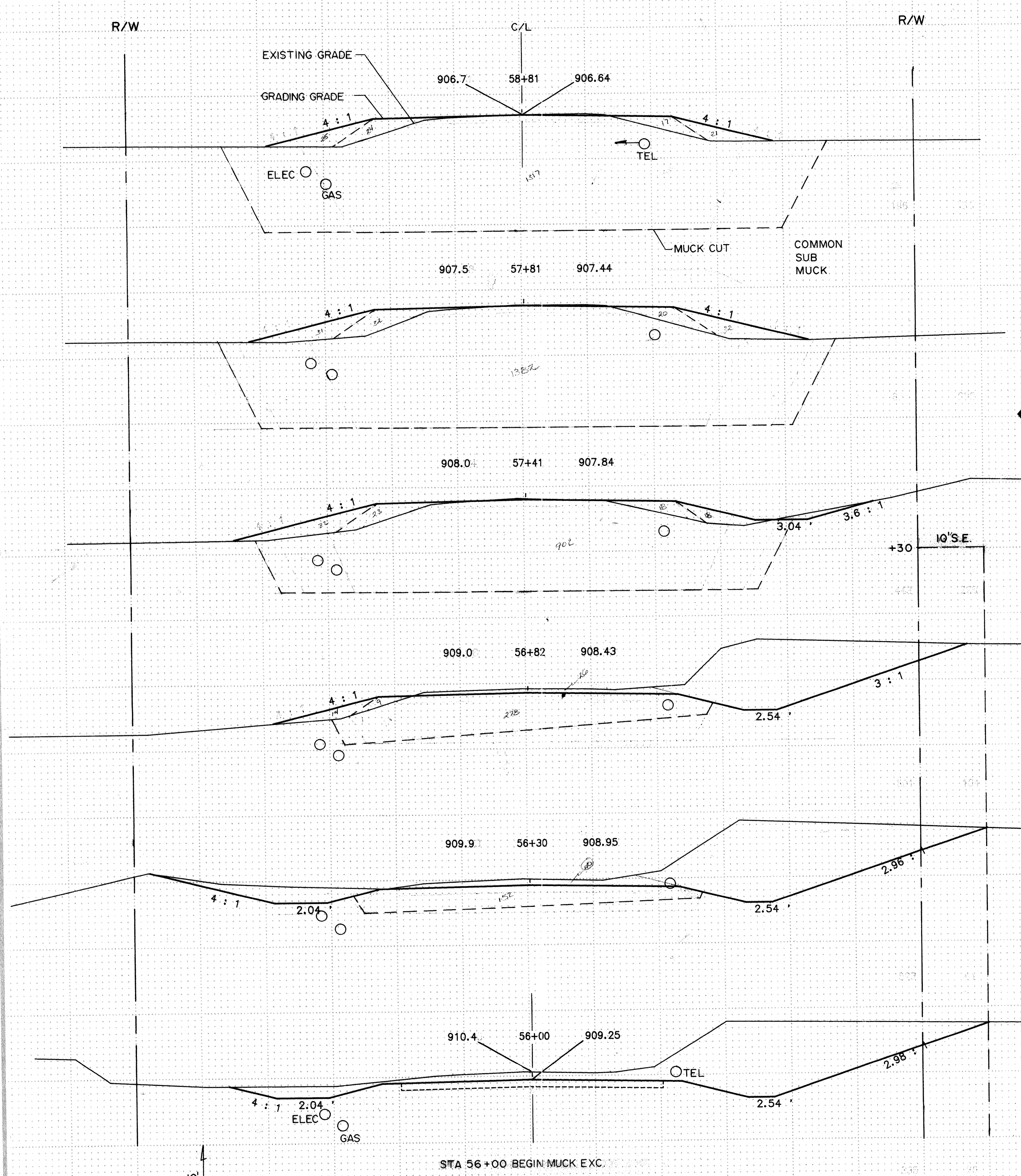

NOTE:  
 UTILITY ELEVATIONS ASSUMED  
 NOT ACTUAL

CROSS-SECTIONS  
 STA. 56+00 TO STA. 63+22

Copy Equipment Form 314 B02722



**EXCAVATION EMBANKMENT**  
 SUB-TOTALS CU.YDS. SUB-TOTALS CU.YDS.

Fed. Proj. No. **EXCAVATION EMBANKMENT**  
 SUB-TOTALS CU.YDS. SUB-TOTALS CU.YDS.

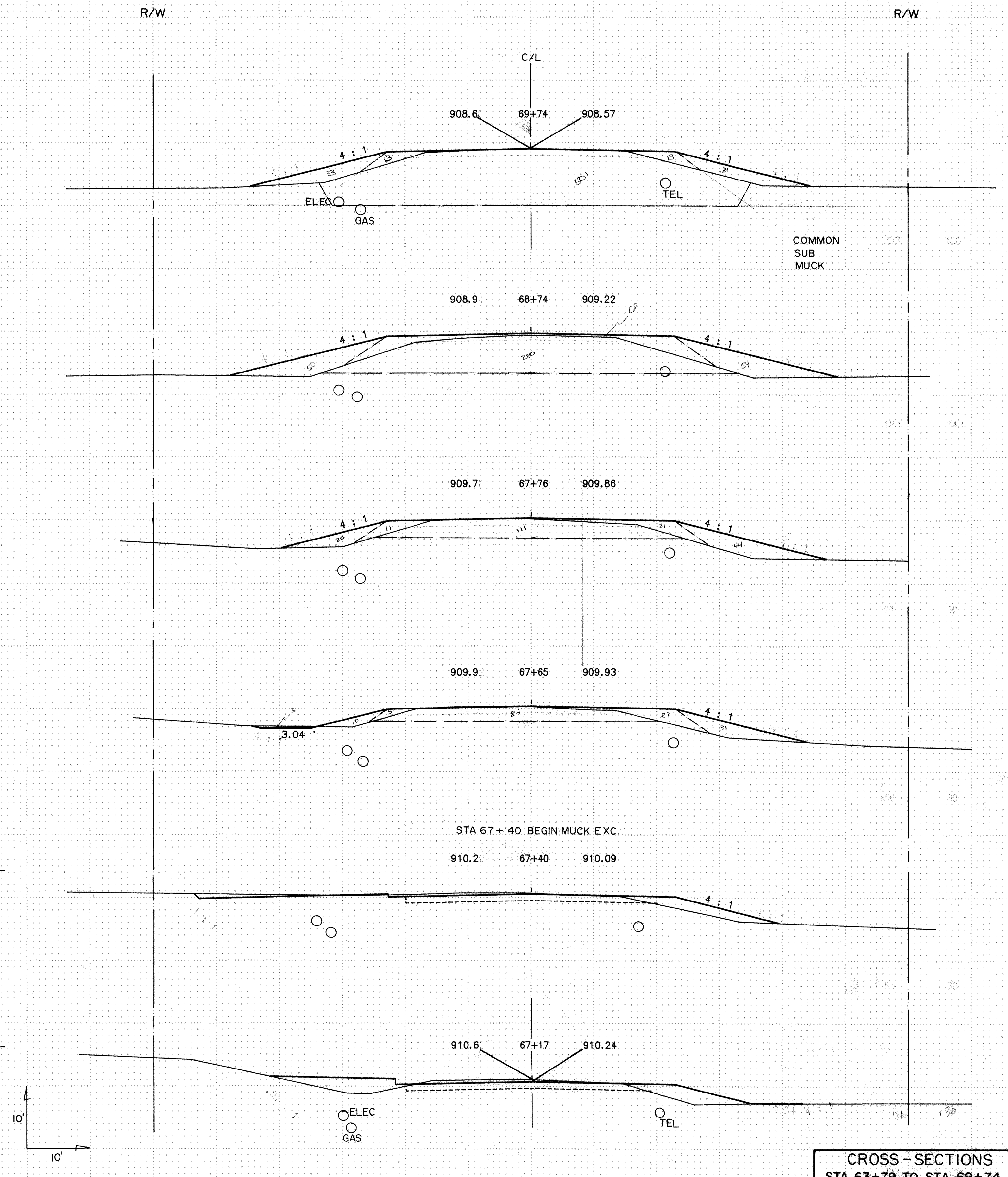
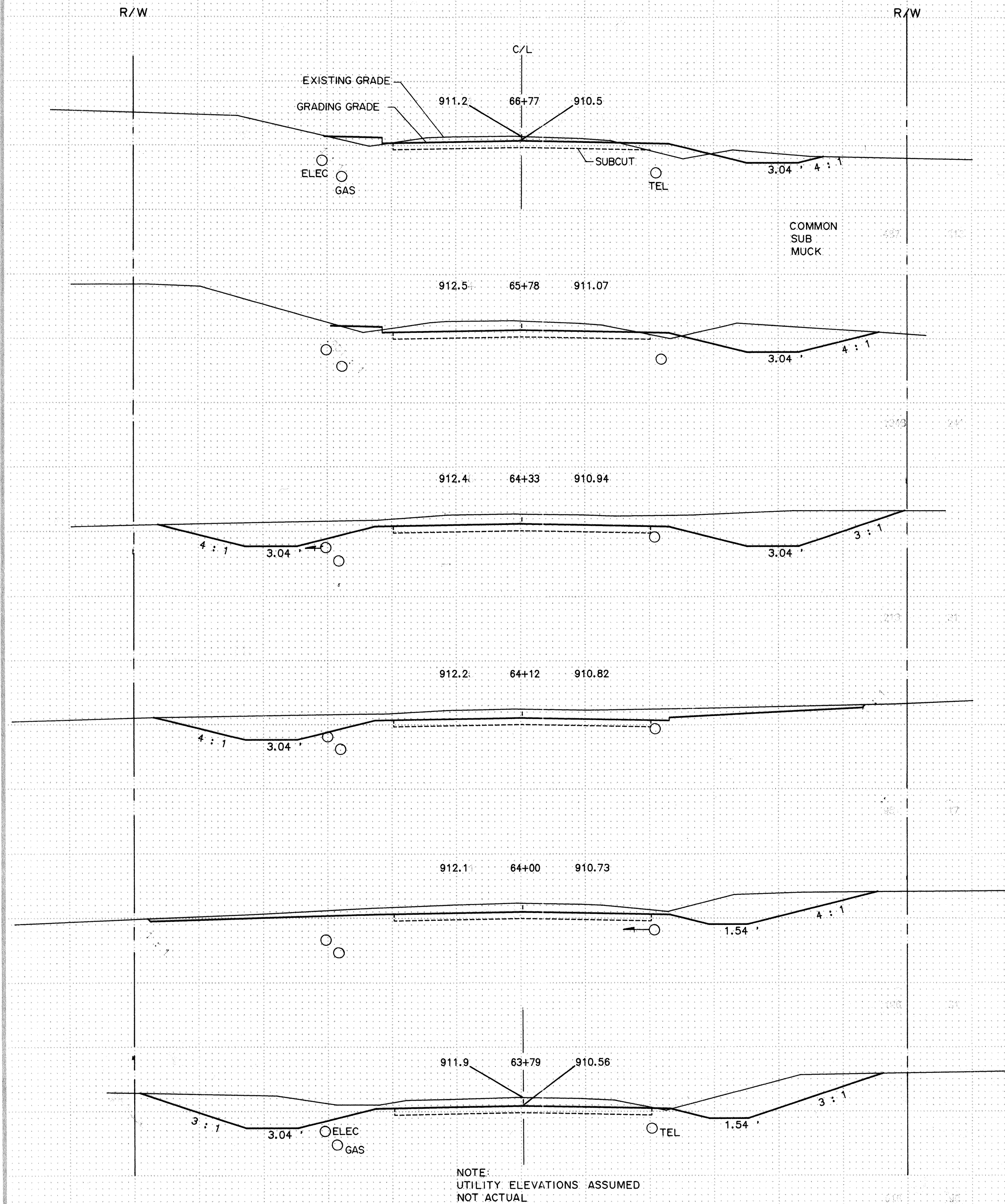

COPY Equipment Form P-14 807275

**EXCAVATION EMBANKMENT**  
 SUB-TOTALS CU.YDS. SUB-TOTALS CU.YDS.

Fed. Proj. No.

**EXCAVATION EMBANKMENT**  
 SUB-TOTALS CU.YDS. SUB-TOTALS CU.YDS.

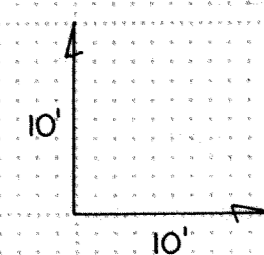
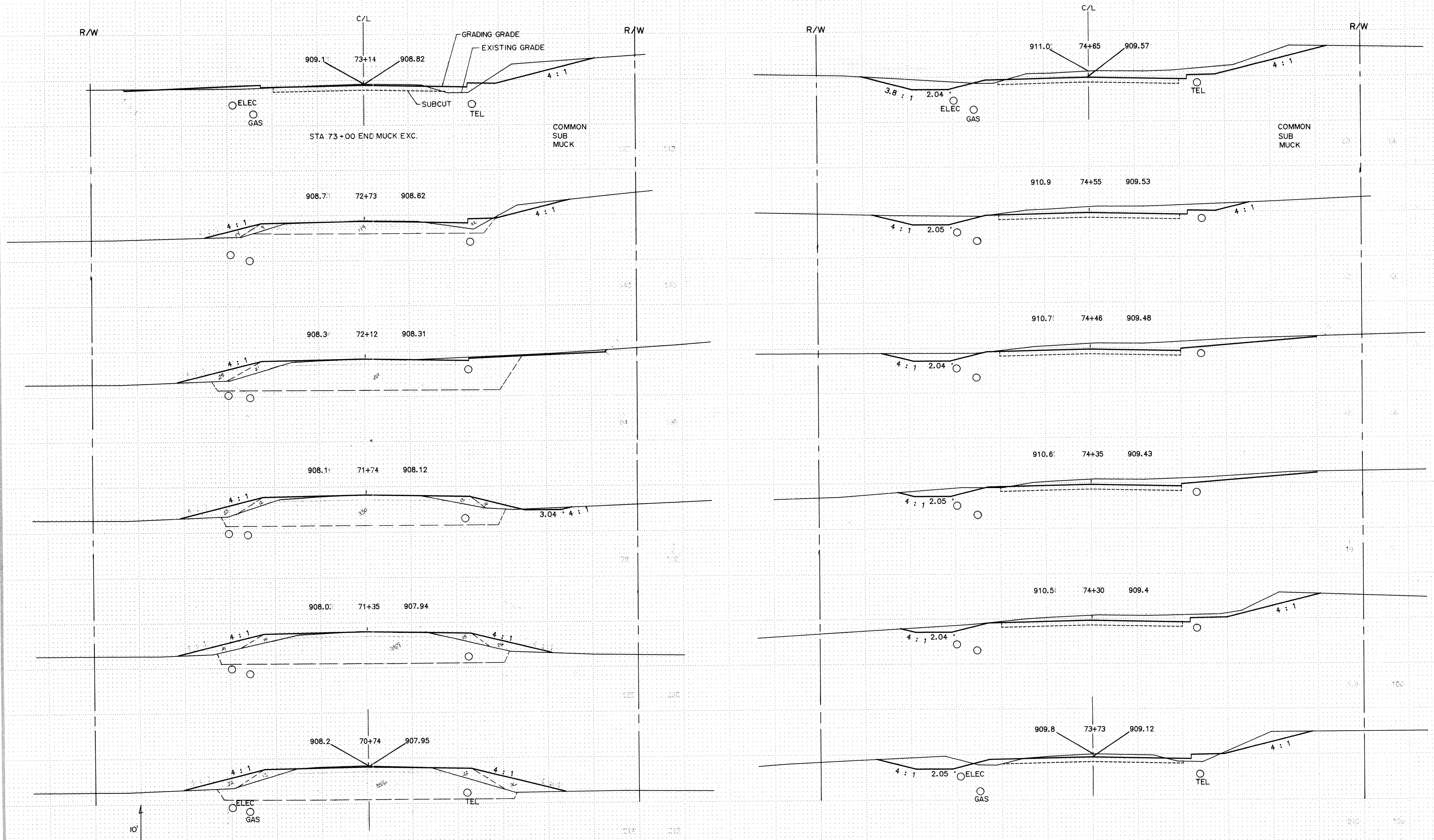

NOTE:  
 UTILITY ELEVATIONS ASSUMED  
 NOT ACTUAL

**EXCAVATION EMBANKMENT**  
 SUB-TOTALS CU.YDS. SUB-TOTALS CU.YDS.

Fed. Proj. No.

**EXCAVATION EMBANKMENT**  
 SUB-TOTALS CU.YDS. SUB-TOTALS CU.YDS.

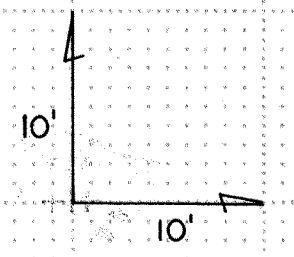
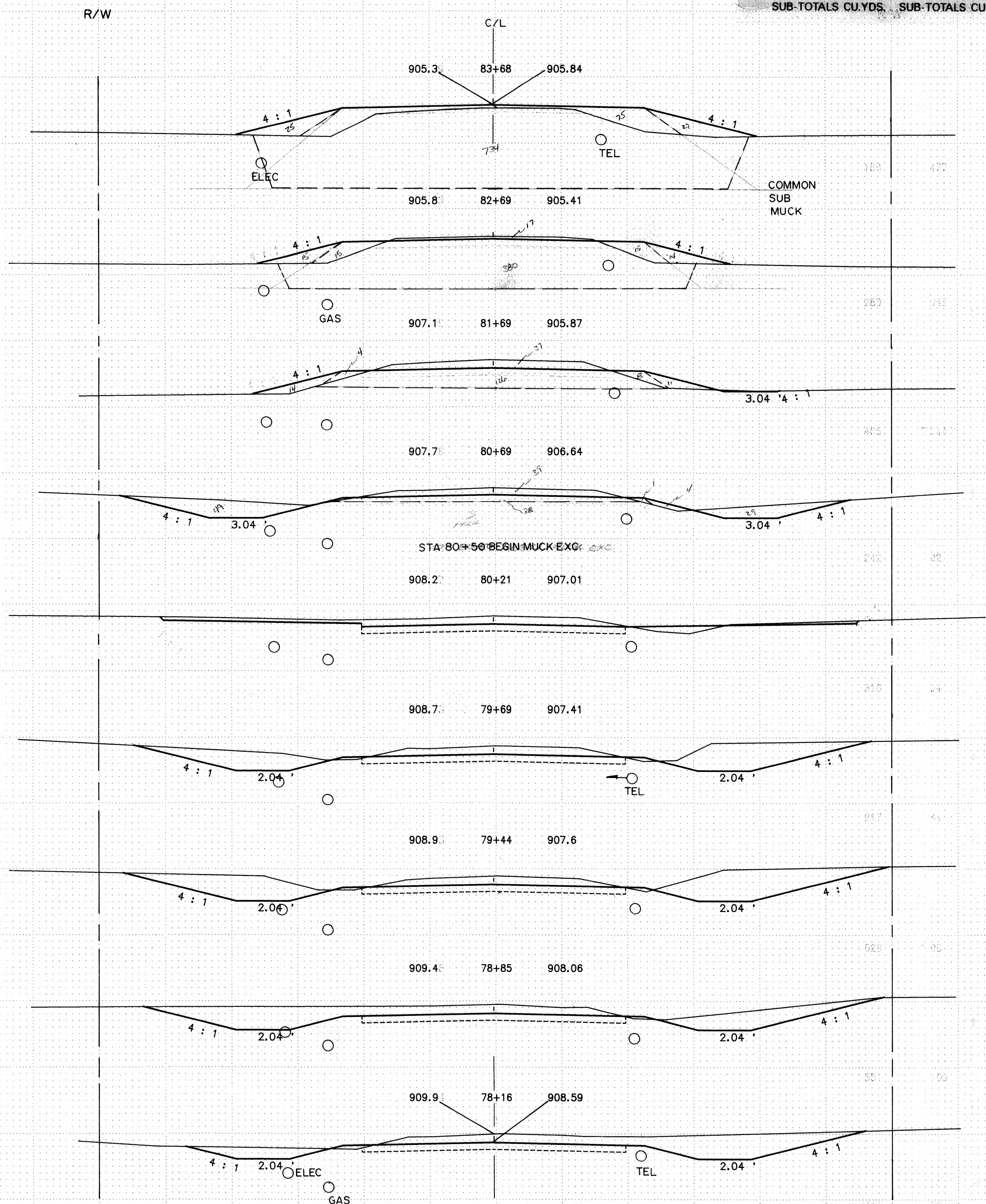
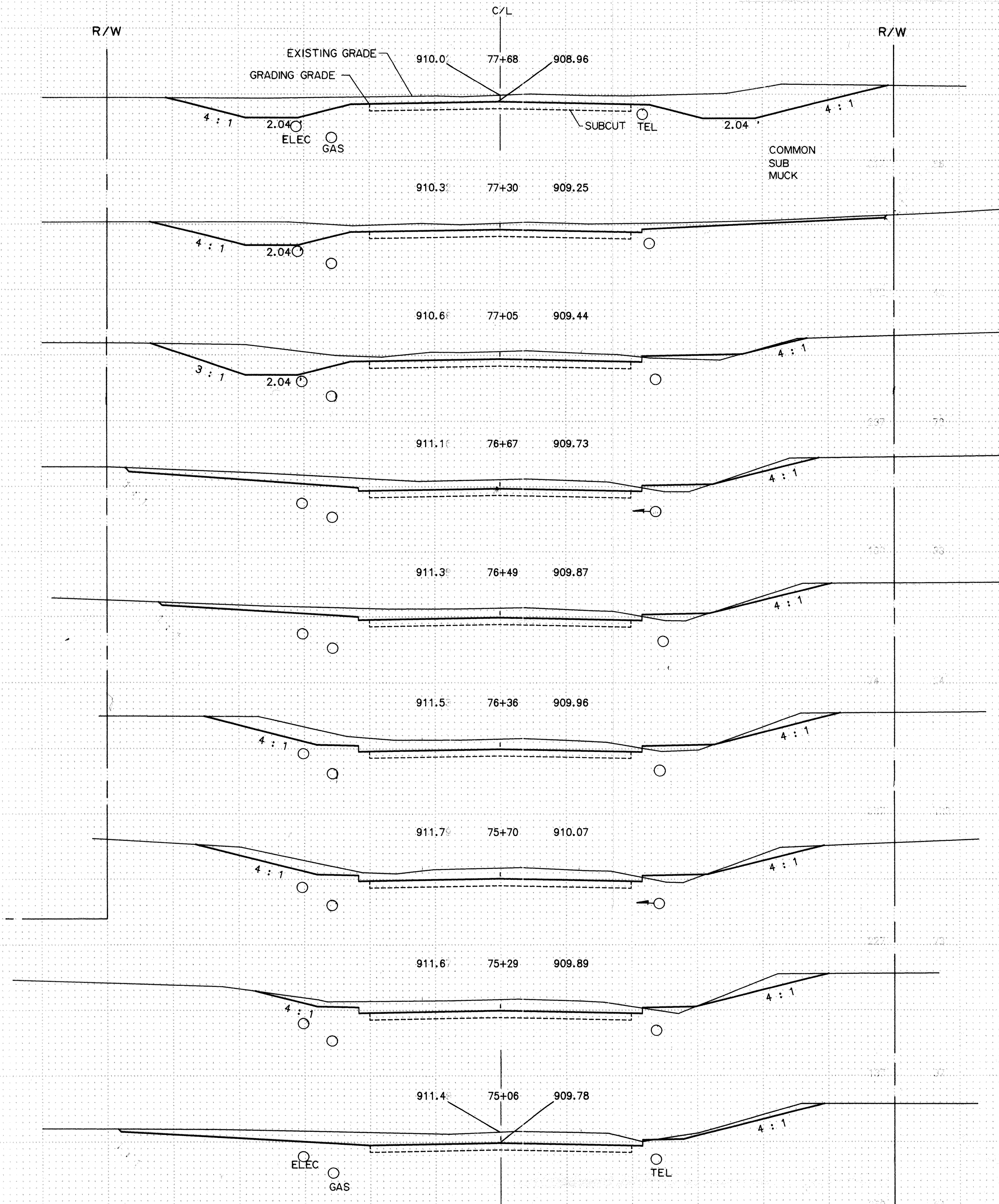

NOTE:  
 UTILITY ELEVATIONS ASSUMED  
 NOT ACTUAL

CROSS-SECTIONS  
 STA. 75+06 TO STA. 83+68

**EXCAVATION EMBANKMENT**  
 SUB-TOTALS CU.YDS. SUB-TOTALS CU.YDS.

Fed. Proj. No. **EXCAVATION EMBANKMENT**  
 SUB-TOTALS CU.YDS. SUB-TOTALS CU.YDS.

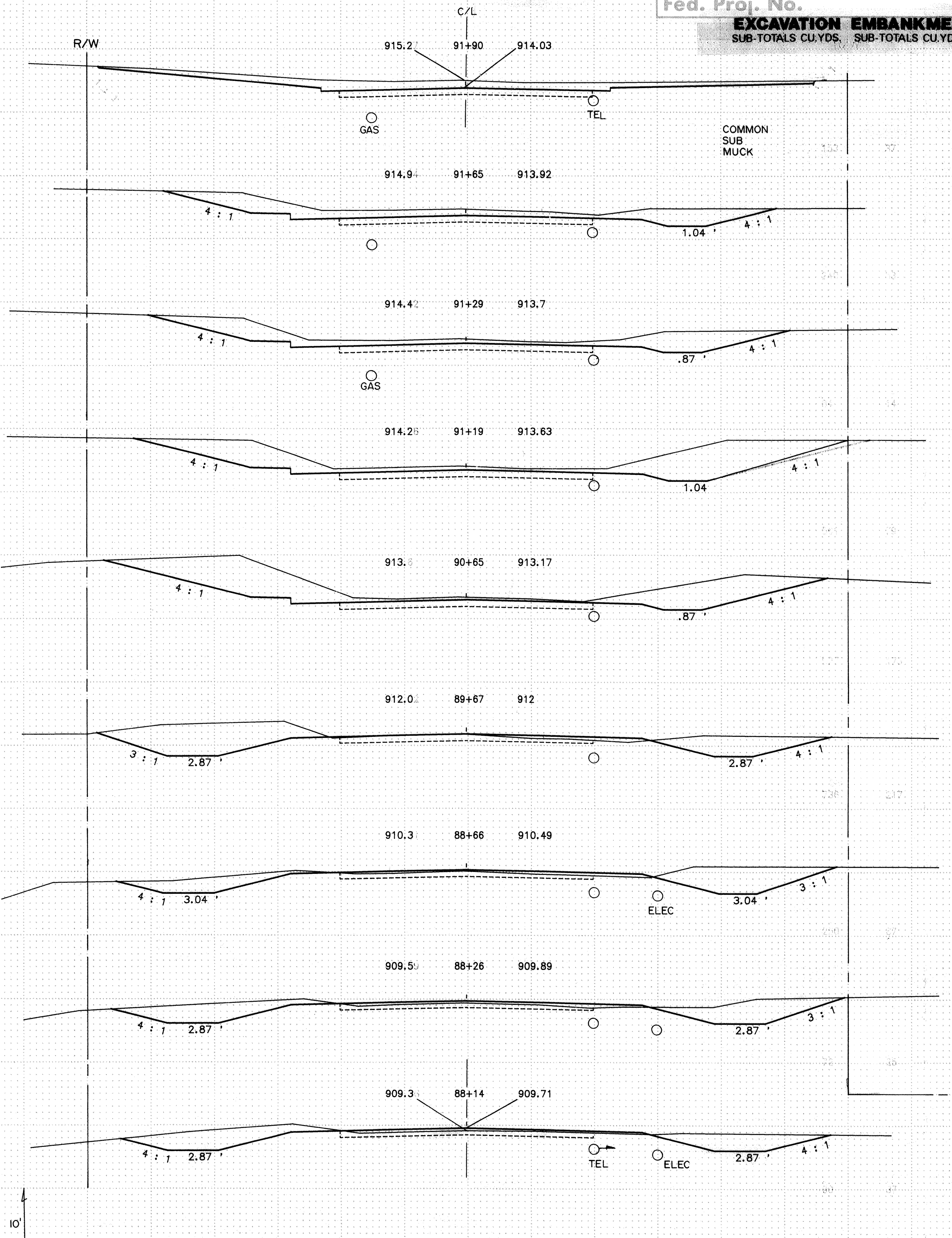
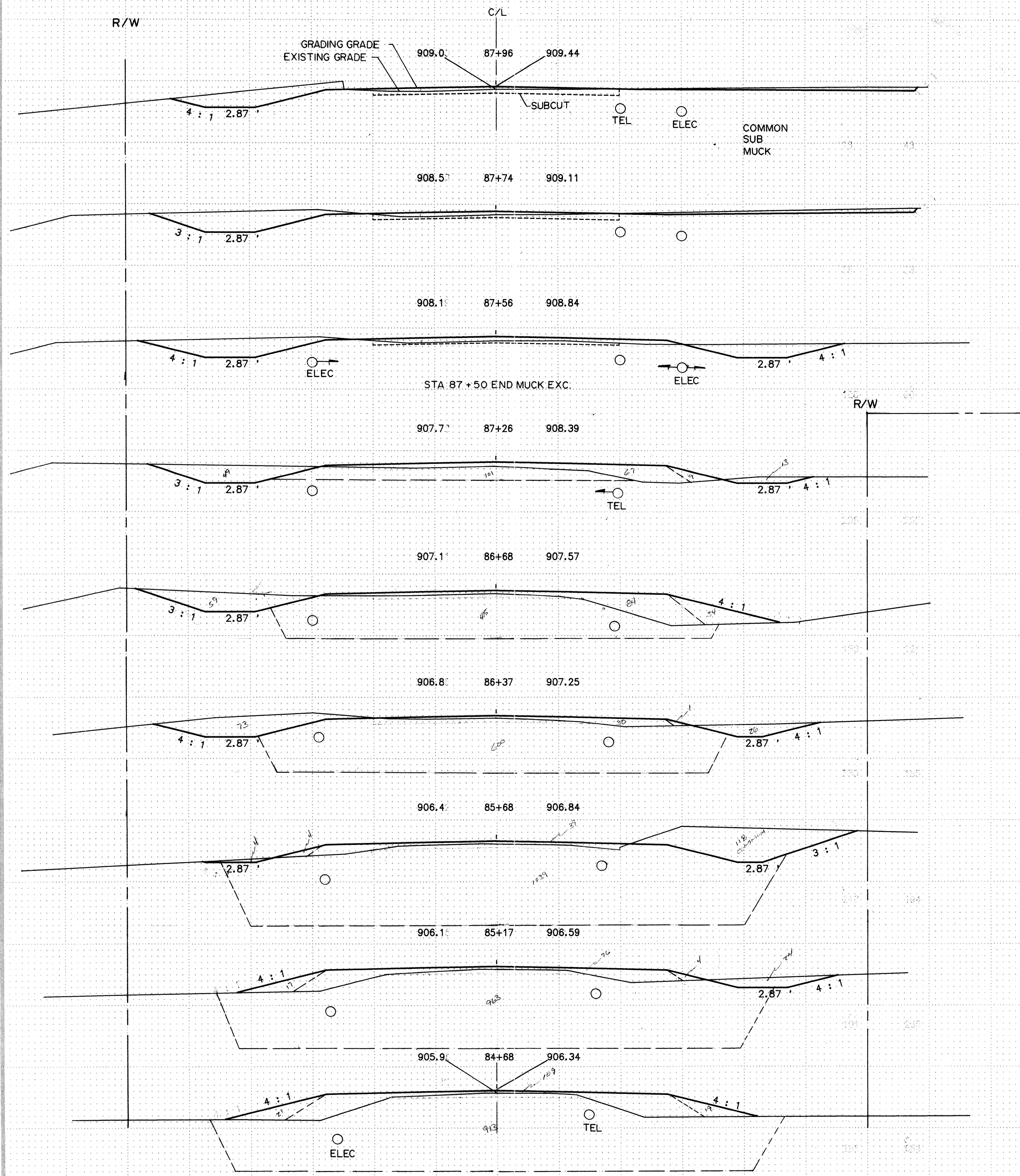

NOTE:  
 UTILITY ELEVATIONS ASSUMED  
 NOT ACTUAL

CROSS-SECTIONS  
 STA. 84+68 TO STA. 91+90

**EXCAVATION EMBANKMENT**  
 SUB-TOTALS CU.YDS. SUB-TOTALS CU.YDS.

Fed. Proj. No.

**EXCAVATION EMBANKMENT**  
 SUB-TOTALS CU.YDS. SUB-TOTALS CU.YDS.

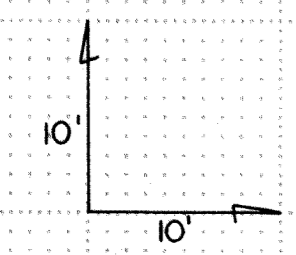
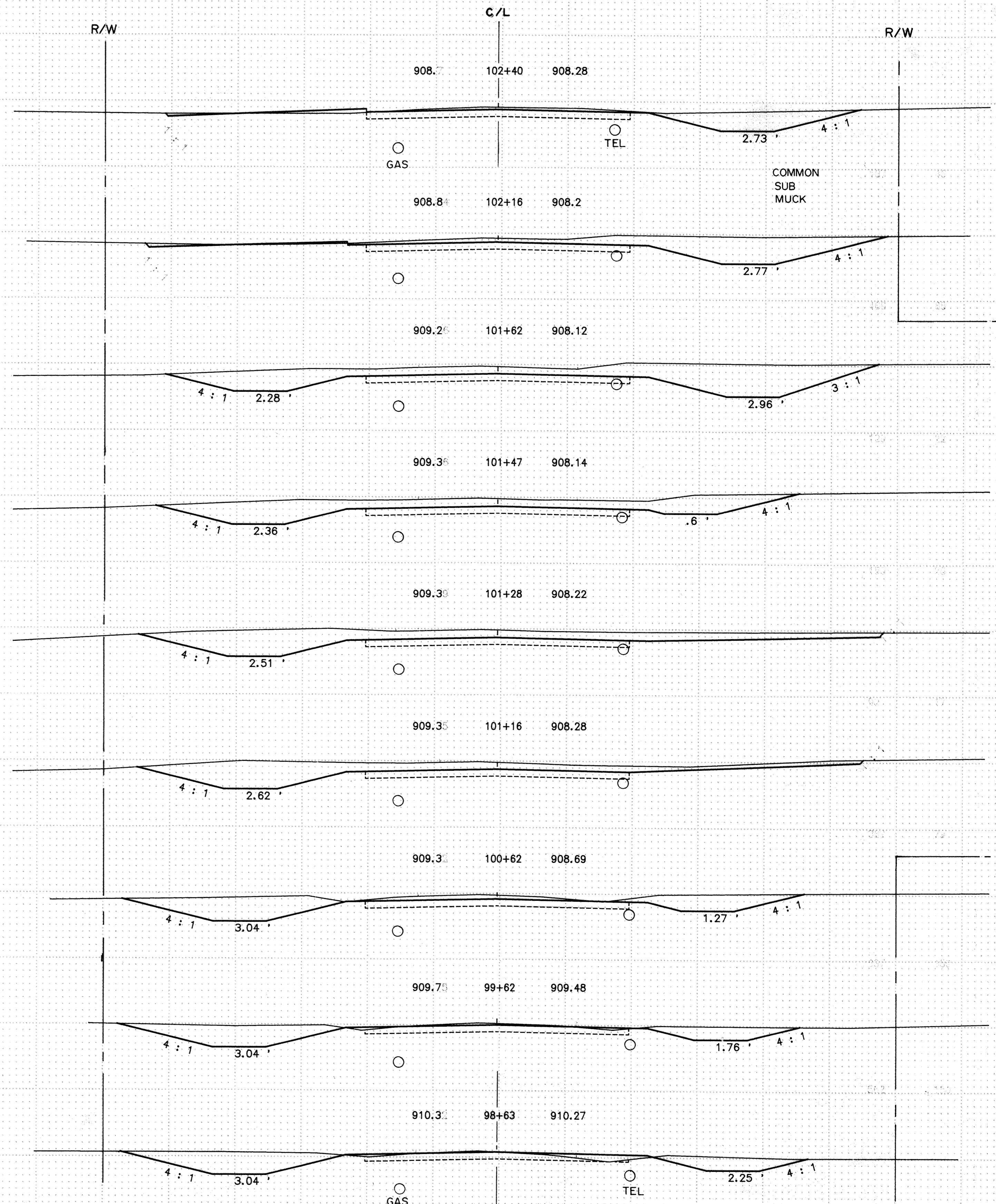
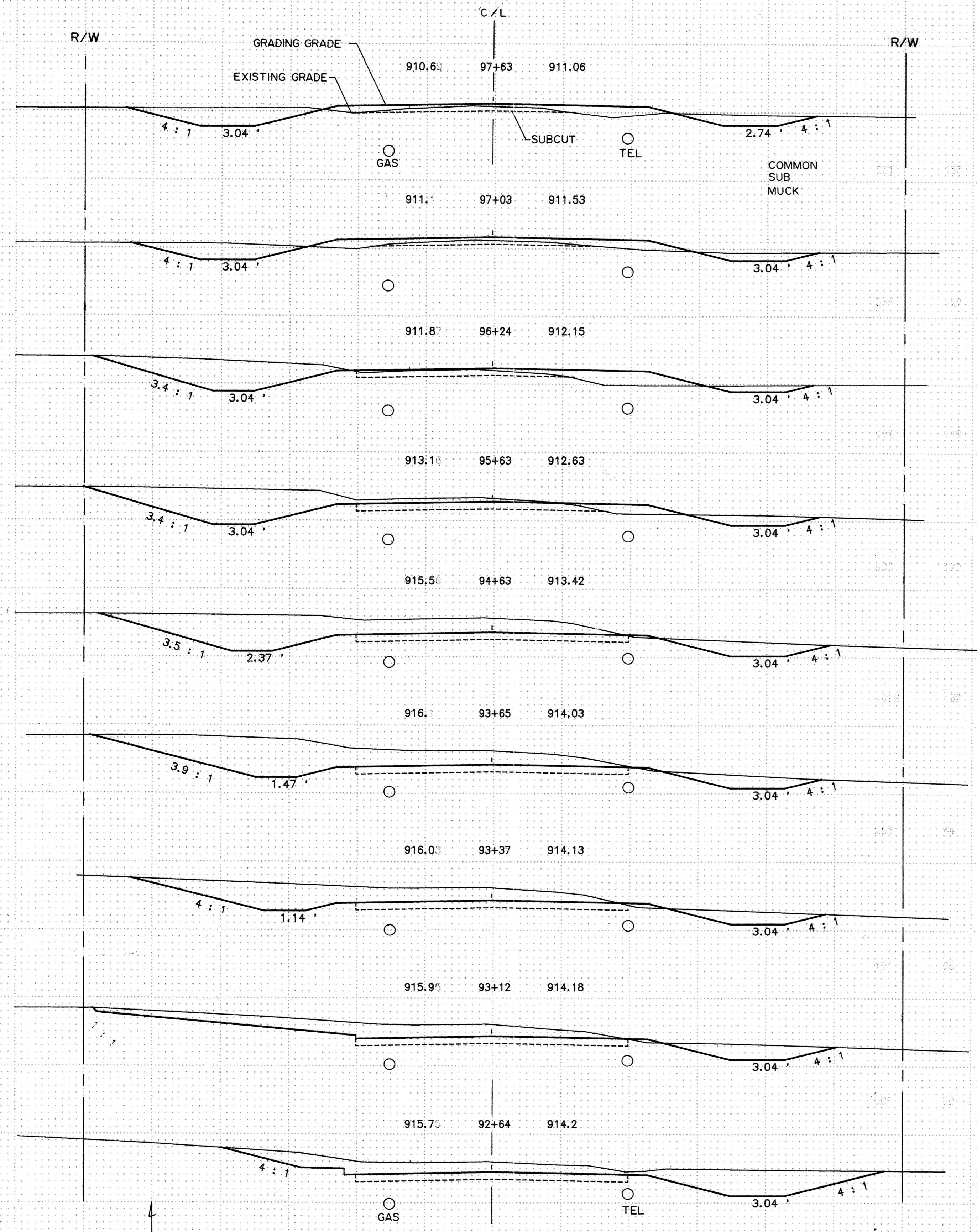

NOTE:  
 UTILITY ELEVATIONS ASSUMED  
 NOT ACTUAL

477 222  
 CROSS-SECTIONS  
 STA. 92+64 TO STA. 102+40

**EXCAVATION EMBANKMENT**  
 SUB-TOTALS CU.YDS. SUB-TOTALS CU.YDS.

Fed. Proj. No. **EXCAVATION EMBANKMENT**  
 SUB-TOTALS CU.YDS. SUB-TOTALS CU.YDS.

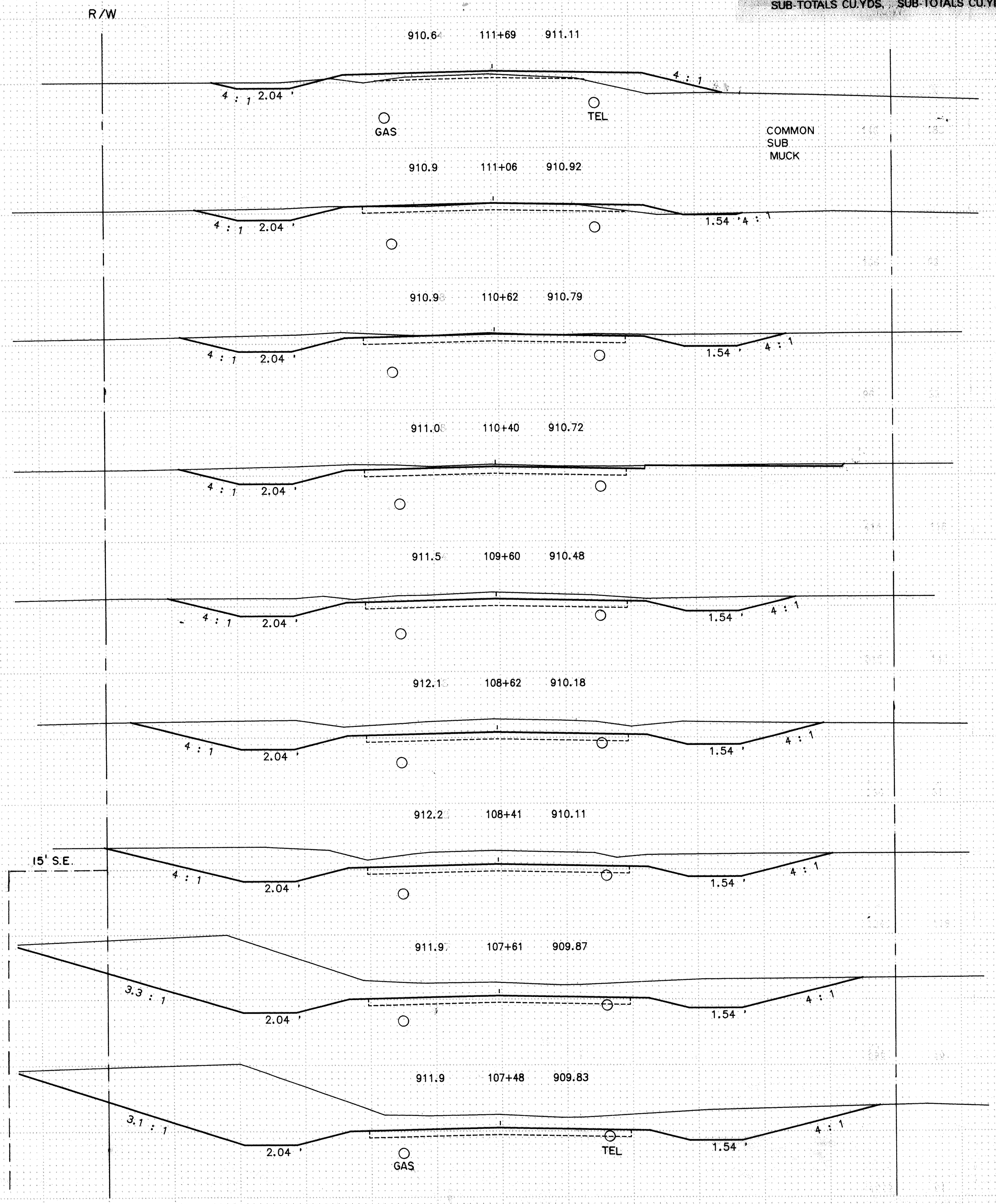
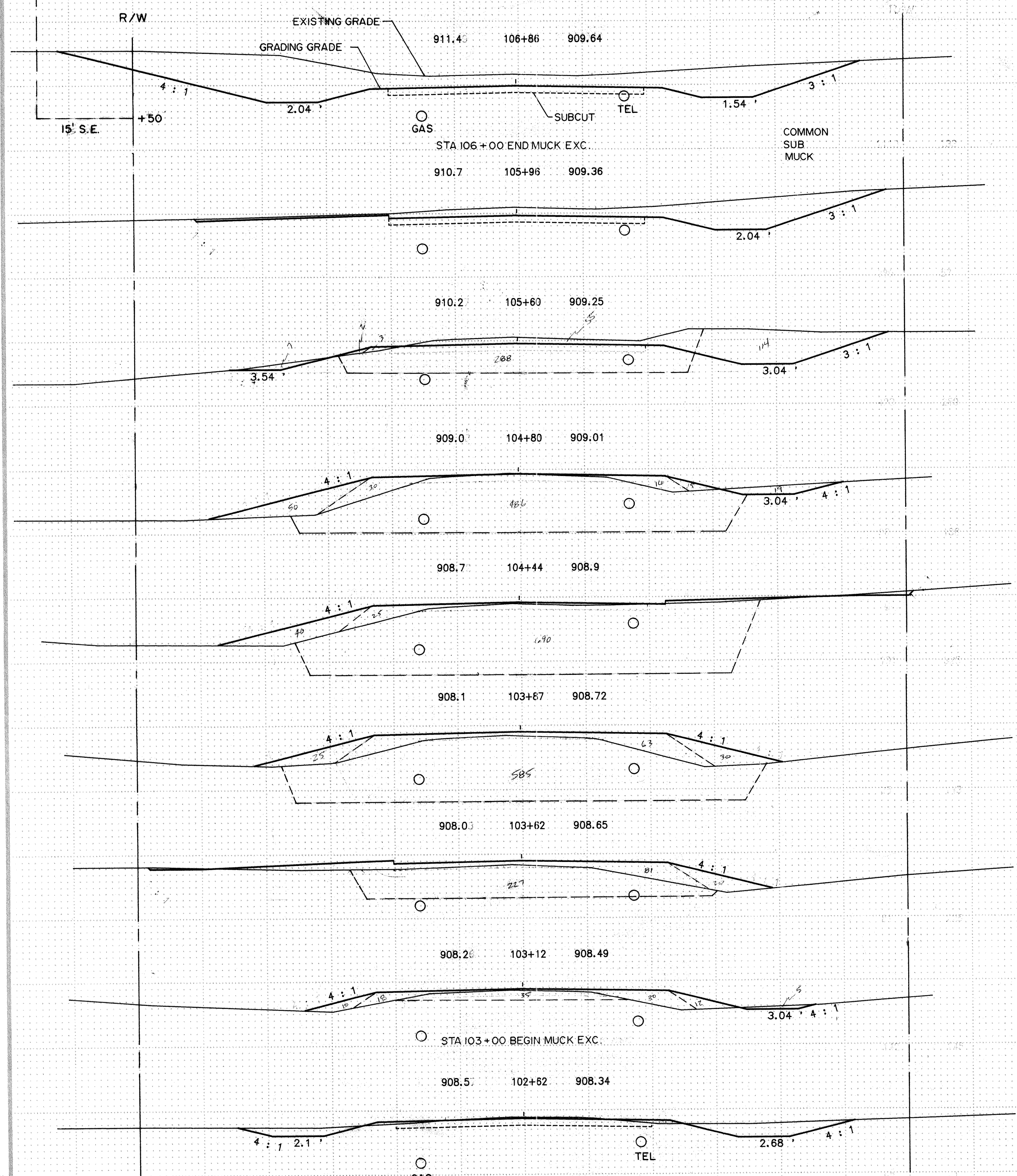

NOTE:  
 UTILITY ELEVATIONS ASSUMED  
 NOT ACTUAL

CROSS-SECTIONS  
 STA. 102+62 TO STA. 111+69

**EXCAVATION EMBANKMENT**  
 SUB-TOTALS CU.YDS. SUB-TOTALS CU.YDS.

Fed. Proj. No. **EXCAVATION EMBANKMENT**  
 SUB-TOTALS CU.YDS. SUB-TOTALS CU.YDS.

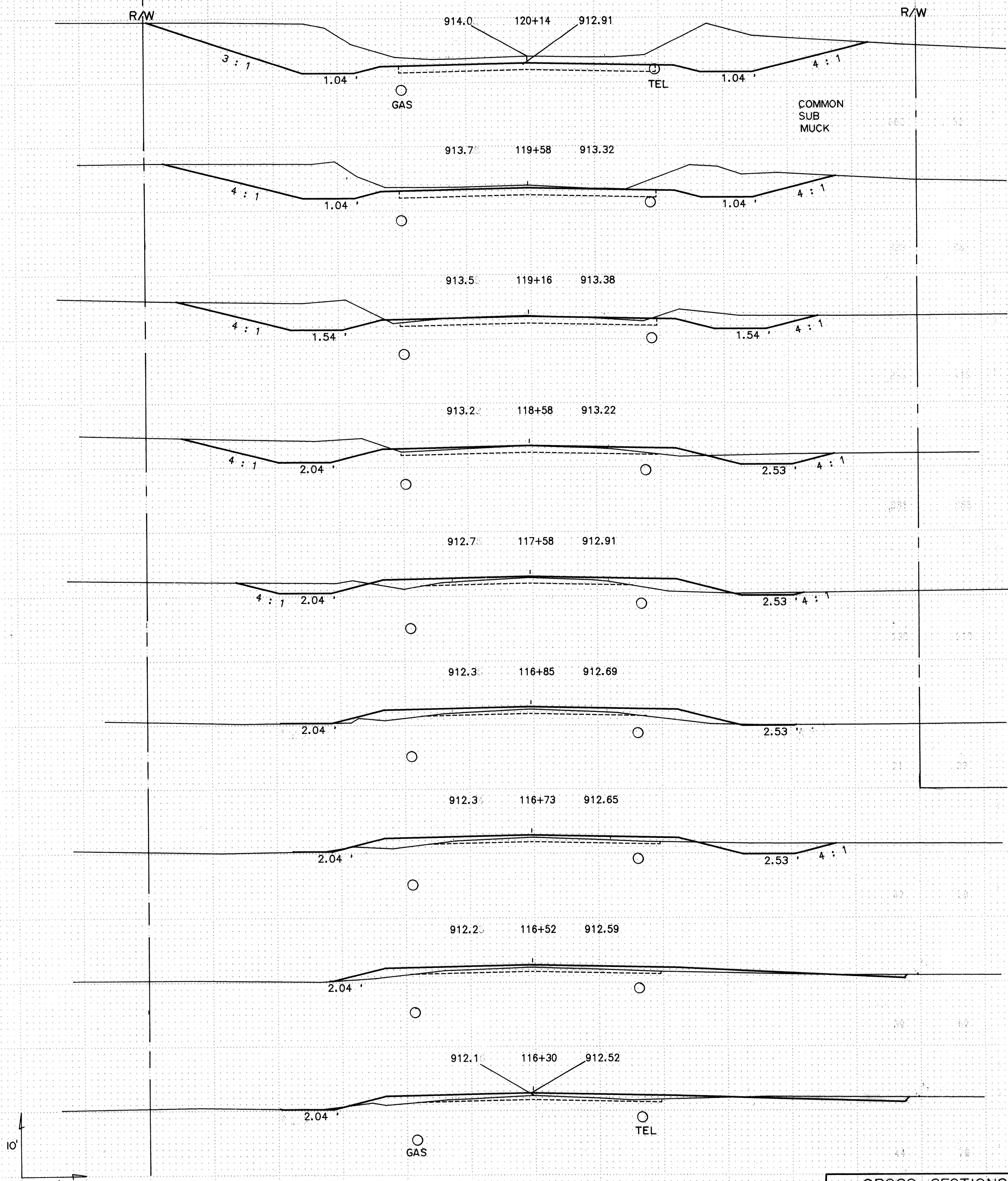
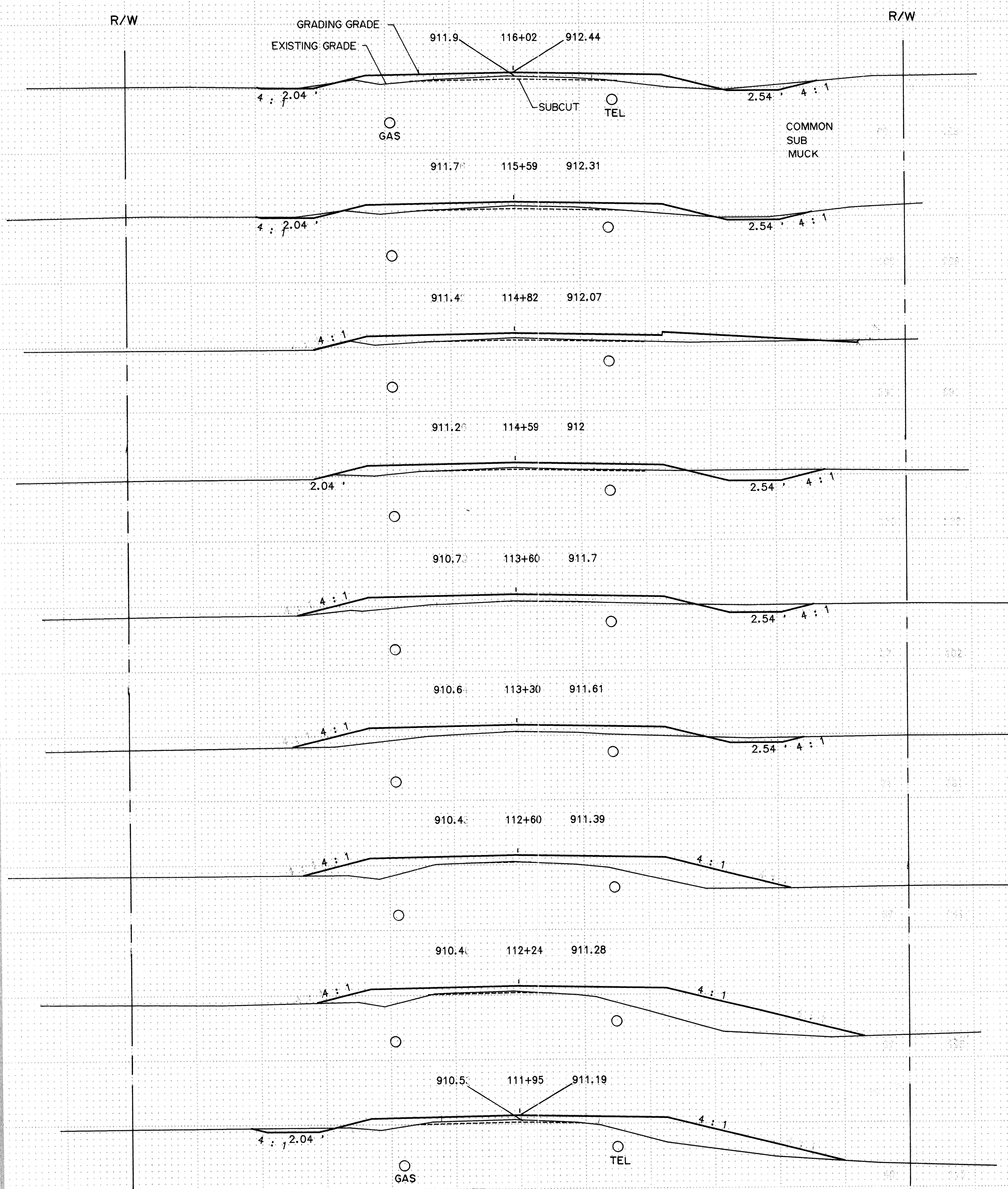

NOTE:  
 UTILITY ELEVATIONS ASSUMED  
 NOT ACTUAL

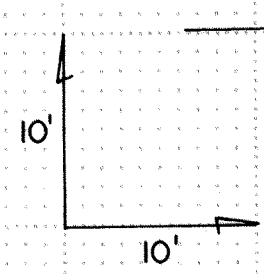

**EXCAVATION EMBANKMENT**  
SUB-TOTALS CU.YDS. SUB-TOTALS CU.YDS.

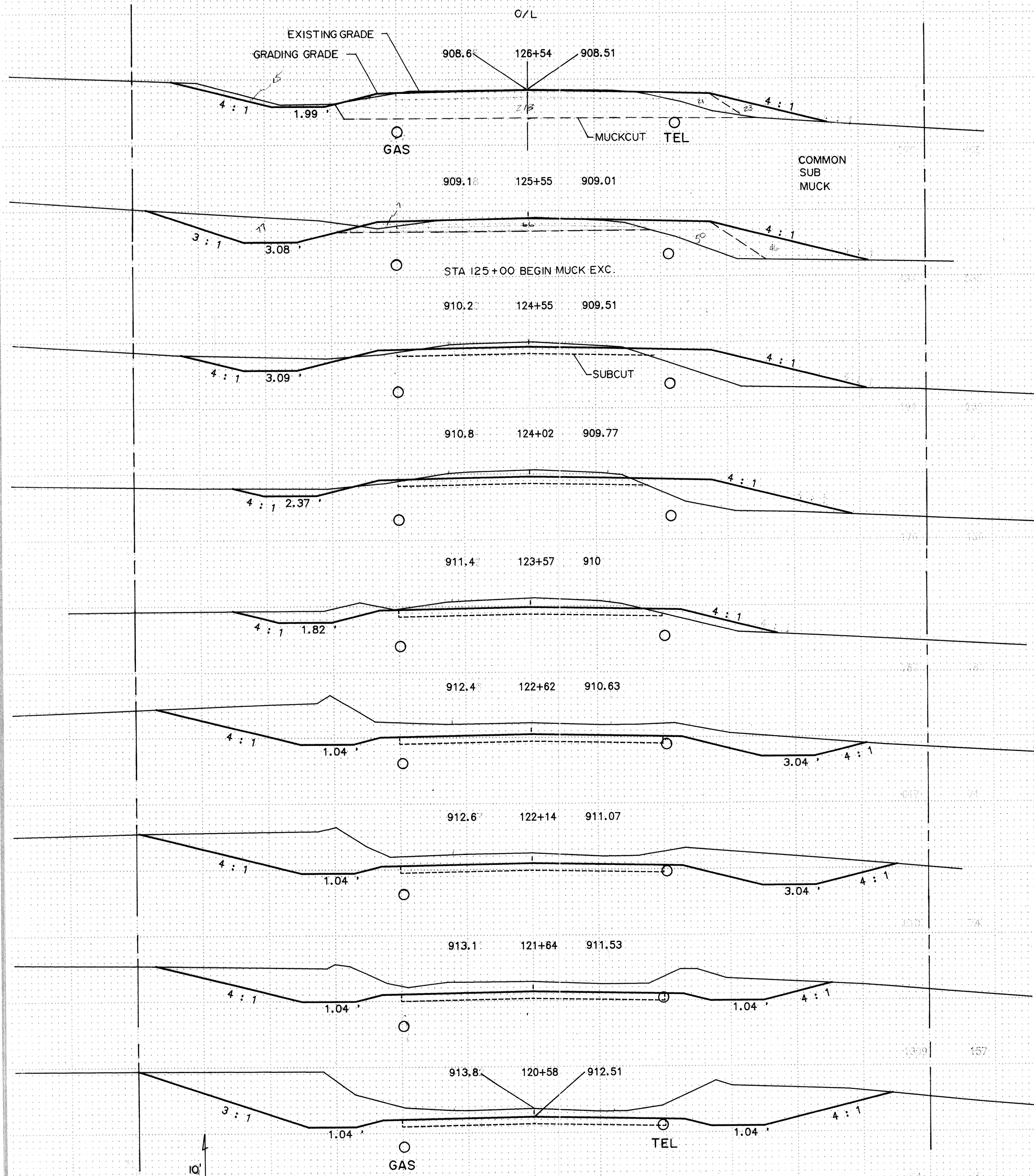

NOTE:  
UTILITY ELEVATIONS ASSUMED  
NOT ACTUAL

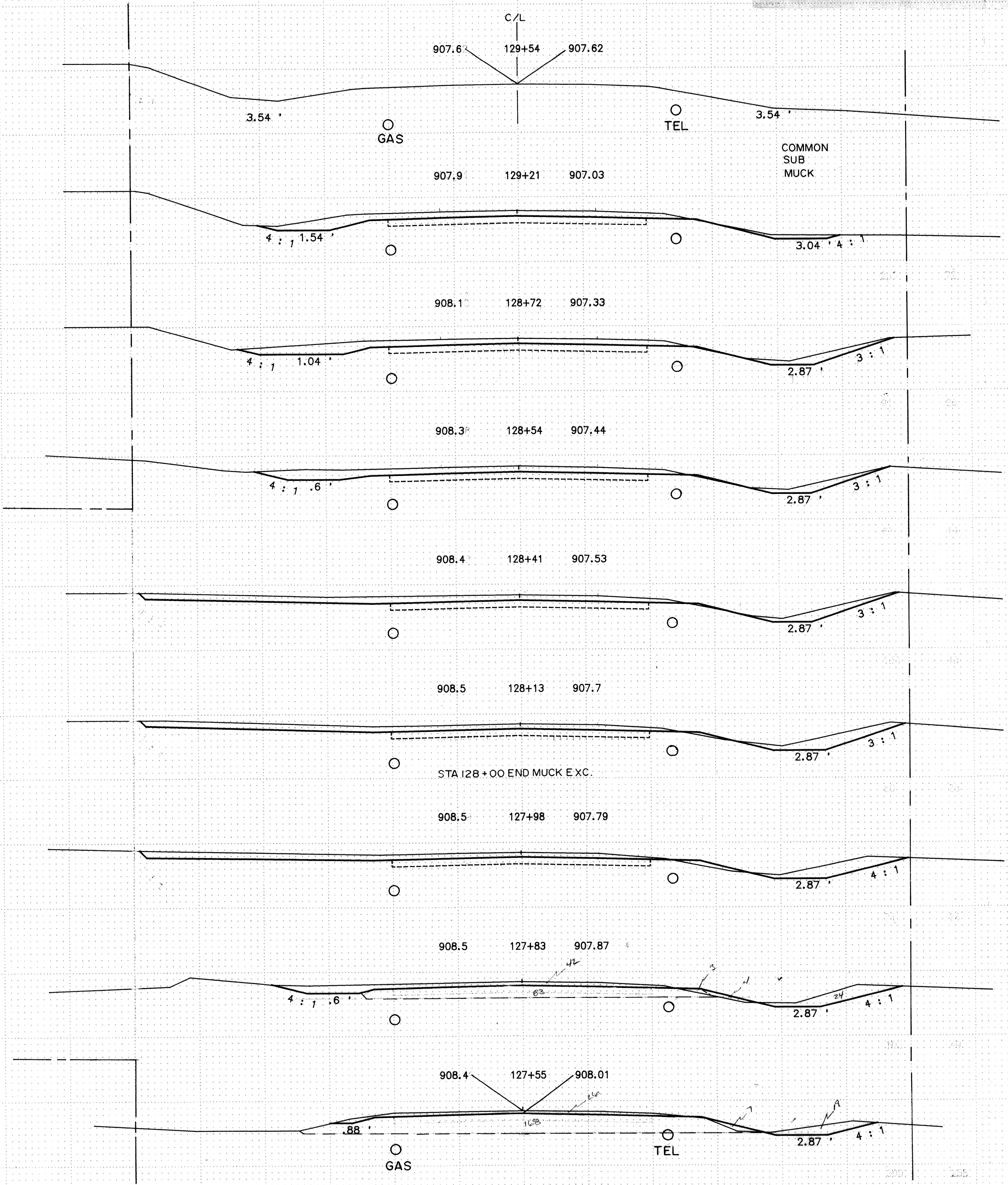

CROSS-SECTIONS  
STA. 120+58 TO STA 129+54



REVISIONS	DATE	BY

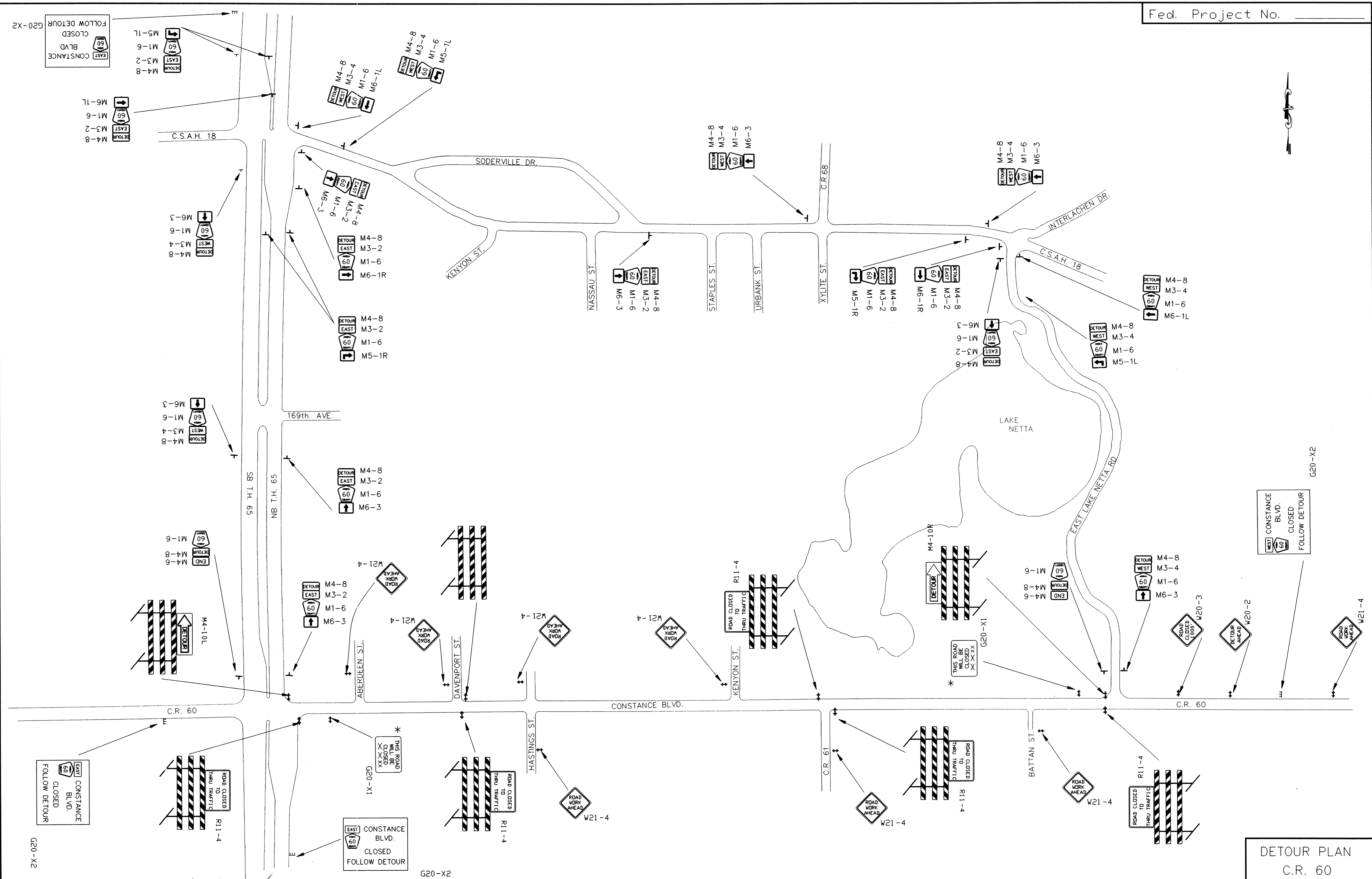

DETOUR PLAN  
C.R. 60

M. U. T. C. D. CODE	SIZE	INSERT	QUANTITY	M. U. T. C. D. CODE	SIZE	INSERT	QUANTITY
W20-2	48" x 48"		• 1	G20-X2MOD	96" x 72"		• 3
W20-3	48" x 48"		• 1	G20-X2MOD	96" x 72"		• 1
W21-4	48" x 48"		• 8	M4-8	24" x 12"		• 3
R11-4	60" x 30"		• 5	M3-2	21" x 12"		• 2
TYPE III	8 FOOT			M1-6	24" x 24"		• 5
					21" x 15"		• 2
M4-10R	48" x 18"		• 1	M4-8	24" x 12"		• 2
TYPE III	8 FOOT			M3-4	21" x 12"		• 2
				M1-6	24" x 24"		• 5
M4-10L	48" x 18"		• 1		21" x 15"		
TYPE III	8 FOOT		• 1	M4-6	24" x 12"		• 2
				M4-8	24" x 12"		
TYPE III	8 FOOT		• 1	M1-6	24" x 24"		
G20-X1	60" x 48"		• 2				

\* SIGNS TO BE INSTALLED A MINIMUM OF SEVEN DAYS PRIOR TO ACTUAL CLOSING DATE OF ROAD CLOSURE AND IMPLEMENTATION OF DETOUR SIGNING. SIGNS TO BE REMOVED AT TIME OF COMPLETED DETOUR INSTALLATION.

NOTES:

- 1) ALL BARRICADES SHALL BE PROPERLY WEIGHTED WITH SANDBAGS.
- 2) ALL BARRICADES SHALL HAVE REFLECTIVE MATERIAL ON BOTH SIDES.
- 3) ALL BARRICADE MARKINGS SHALL BE SLANTED IN ACCORDANCE WITH THE MINNESOTA MANUAL OF UNIFORM TRAFFIC CONTROL DEVICES.
- 4) ALL TRAFFIC CONTROL DEVICES SHALL CONFORM TO THE MOST RECENT EDITION OF THE MINNESOTA MANUAL ON UNIFORM TRAFFIC CONTROL DEVICES, INCLUDING THE FIELD MANUAL DATED APRIL 1995.
- 5) ADDITIONS OR CHANGES TO THIS PLAN MAY BE MADE AS DETERMINED BY THE ENGINEER.

REVISIONS	BY	DATE

DETOUR PLAN  
C.R. 60