

MINNESOTA DEPARTMENT OF TRANSPORTATION ANOKA COUNTY

CONSTRUCTION PLAN FOR GRADING, AGGREGATE BASE AND BITUMINOUS SURFACING.

LOCATED ON CR 60 BETWEEN TH 65 AND EAST LAKE NETTA DRIVE (GEOGRAPHIC DESCRIPTION)

FROM A POINT 162.66' E. AND 1331.56' S. OF THE N.1/4 COR. OF SEC. 17, T-32 N. R-23 W. TO A POINT 1191.08' W. AND 1328.18' S. OF THE N.E. COR. OF SEC. 15, T-32 N. R-23 W. (LEGAL DESCRIPTION)

COUNTY PROJ. NO. 93-04-60

GROSS LENGTH	11,945	FEET	2.262	MILES
BRIDGES-LENGTH	0	FEET	0	MILES
EXCEPTIONS-LENGTH	0	FEET	0	MILES
NET LENGTH	11,945	FEET	2.262	MILES

93-04-60

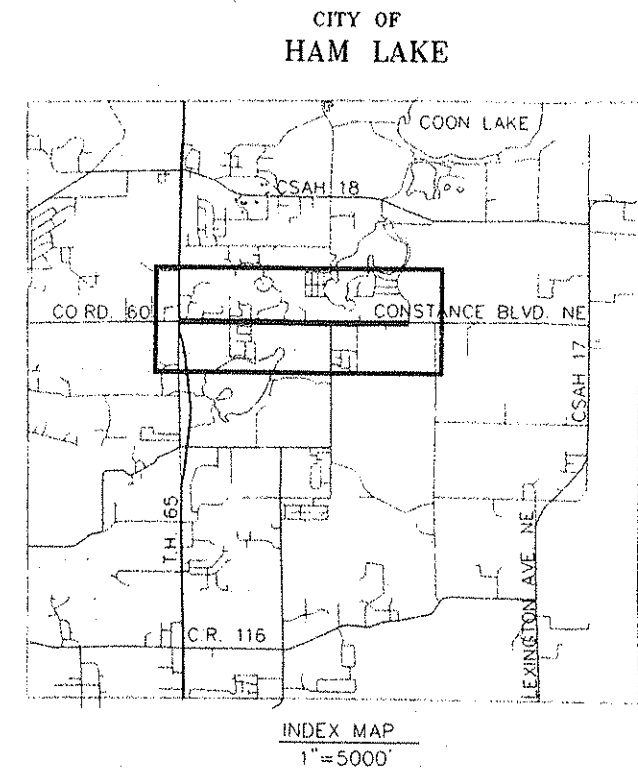
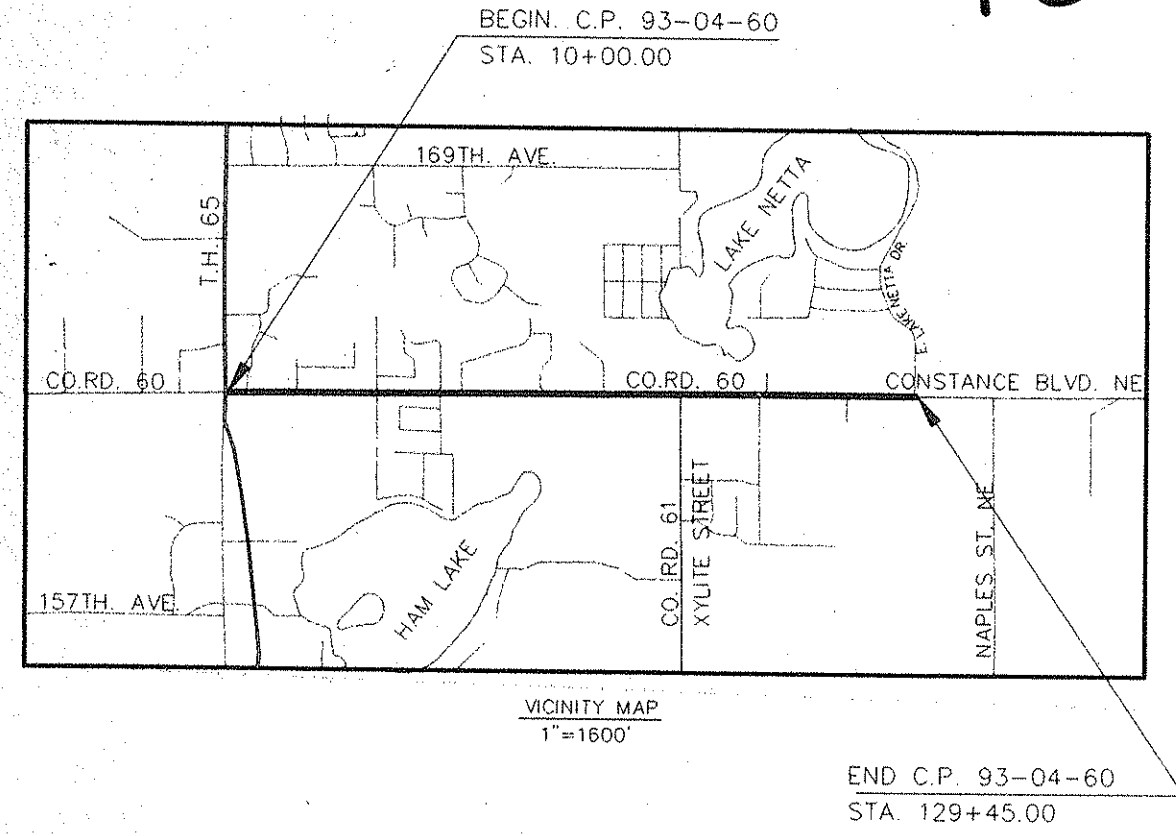

MINN. PROJ. NO. LOCAL FUNDS
GOVERNING SPECIFICATIONS
THE 1988 EDITION OF THE MINNESOTA DEPARTMENT OF TRANSPORTATION "STANDARD SPECIFICATIONS FOR CONSTRUCTION" AS AMENDED BY THE MAY 2, 1994 SUPPLEMENTAL SPECIFICATIONS SHALL GOVERN.

SHEET NO.	DESCRIPTION
1	TITLE SHEET
2	STATEMENT OF ESTIMATED QUANTITIES
3-5	TABULATION CHARTS
6	EARTHWORK SUMMARY
7	STANDARD DETAILS
8-9	EROSION CONTROL DETAILS
10-11	TYPICAL SECTIONS
12-16	EXISTING CONDITIONS AND REMOVAL PLAN
17-25	PLAN AND PROFILE
26-40	CROSS-SECTION
41-42	DETOUR PLAN

THIS PLAN CONTAINS 42 SHEETS

DESIGN DESIGNATION

ΣN18 ₂₀	901,764
R VALUE	70
ADT (1996)=	4550
Proj. ADT (2016)=	7735
Proj. HCADT (2016)=	580
Soil Factor	N/A
10 TON DESIGN	
Shoulder Width	8 FT.

Functional Classification
No. of Traffic Lanes 2. No. of Parking Lanes 0
Design Speed 55 MPH
Based on Stopping Sight Distance
Height of eye 3.5' Height of object 0.5'
Design Speed not achieved at:

STA.	TO STA.	MPH
STA.	TO STA.	MPH
STA.	TO STA.	MPH

I HEREBY CERTIFY THAT THIS PLAN WAS PREPARED BY ME OR UNDER MY DIRECT SUPERVISION AND THAT I AM A DULY REGISTERED PROFESSIONAL ENGINEER UNDER THE LAWS OF THE STATE OF MINNESOTA

DATE April 30, 19 REG. NO. 20235 ENGR. K. JOHNSON AND M. NAJI
DESIGN SQUAD

Recommended for Approval: [Signature] RIGHTS-OF-WAY SECTION 5/12/19
Recommended for Approval: [Signature] TRAFFIC SECTION 5/12/19
Recommended for Approval: [Signature] CONSTRUCTION ENGINEER 5/12/19
Approved May 2, 19 ANOKA COUNTY ENGINEER
Approved .19. CITY OF HAM LAKE ENGINEER

PLAN SYMBOLS

- COUNTY LINE
- TOWNSHIP OR RANGE LINE
- SECTION LINE
- QUARTER LINE
- SIXTEENTH LINE
- RIGHT OF WAY LINE
- SLOPE EASEMENT
- PRESENT RIGHT OF WAY
- PROPERTY LINE
- CORPORATE OR CITY LIMITS
- RETAINING WALL
- RAILROAD
- RAILROAD RIGHT OF WAY
- RIVER OR CREEK
- DRAINAGE DITCH
- CULVERT
- DROP INLET
- GAULD RAIL
- BARBED WIRE FENCE
- WOVEN WIRE FENCE
- CHAIN LINK FENCE
- WOOD FENCE
- STONE WALL OR FENCE
- HEDGE

- LOWLAND
- TIMBER
- ORCHARD
- BRUSH
- NURSERY

- CATTLE GAULD

- OVERPASS (Highway Over)

- UNDERPASS (Highway Under)

- BRIDGE

- BUILDING (One Story Frame)
- F-FRAME C-CONCRETE
- S-STONE T-TILE
- B-BRICK ST-STUCCO

- RAILROAD CROSSING BELL
- RAILROAD CROSSING GATE
- MANHOLE
- CATCH BASIN
- FIRE HYDRANT
- CAST IRON MONUMENT
- IRON PIN
- GRAVEL PIT
- SAND PIT
- BORROW PIT
- POCK QUARRY
- GEOTECHNICAL BORINGS

UTILITY SYMBOLS

- POWER POLE LINE
- TELEPHONE OR TELEGRAPH POLE LINE
- JOINT TELEPHONE & POWER ON POWER POLES
- ON TELEPHONE POLES
- ANCHOR
- STEEL TOWER
- STREET LIGHT
- PEDESTAL (Cable Termination)
- GAS MAIN
- WATERMAIN
- TELEPHONE CABLE IN CONDUIT
- ELECTRIC CABLE IN CONDUIT
- TELEPHONE MANHOLE
- ELECTRIC MANHOLE
- BURIED TELEPHONE CABLE
- BURIED ELECTRIC CABLE
- AERIAL TELEPHONE CABLE
- SEWER (Sanitary or Storm)
- SEWER MANHOLE

SCALES

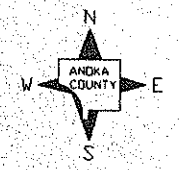
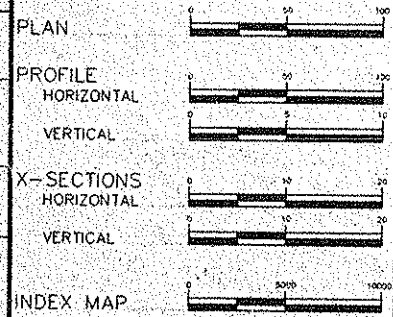

REVISIONS	DATE	BY

COUNTY PROJ. NO. 93-04-60
STATE PROJ. NO.

SHEET NO. 1 OF 42 SHEETS

STATEMENT OF ESTIMATED QUANTITIES

Fed. Project No. _____

CHART NO.	ITEM NO.	ITEM	UNIT	TOTAL QUANTITIES		ANDKA COUNTY	
				ESTIMATED	FINAL	C.P. 93-04-60 ESTIMATED	C.P. 93-04-60 FINAL
	0013.601	CELLULAR MOBILE TELEPHONE	LUMP SUM	1		1	
	0013.601	SURVEY EQUIPMENT	LUMP SUM	1		1	
	0015.601	COMPUTER EQUIPMENT	LUMP SUM	1		1	
	2021.501	MOBILIZATION	LUMP SUM	1		1	
	2031.501	FIELD OFFICE TYPE D	EACH	1		1	
	A 2101.501	CLEARING	ACRE	3.35		3.35	
	A 2101.502	CLEARING	TREE	331		331	
	A 2101.506	GRUBBING	ACRE	3.35		3.35	
	A 2101.507	GRUBBING	TREE	292		292	
①	H 2104.501	REMOVE FENCE	LIN FT	255		255	
①	R 2104.501	REMOVE CULVERT PIPE	LIN FT	450		450	
	C 2104.501	REMOVE CONCRETE RETAINING WALL	LIN FT	18		18	
②	D 2104.505	REMOVE BITUMINOUS PAVEMENT	SQ YD	31012		31012	
③	I 2104.505	REMOVE CONCRETE PAVEMENT	SQ YD	144		144	
	G 2104.509	REMOVE BITUMINOUS FLUME	EACH	4		4	
	K 2104.509	REMOVE DRAINAGE STRUCTURE	EACH	2		2	
	F 2104.511	SAVING CONCRETE PAVEMENT	LIN FT	38		38	
	E 2104.513	SAVING BITUMINOUS PAVEMENT	LIN FT	1275		1275	
①	H 2104.521	SALVAGE FENCE	LIN FT	3698		3698	
①	Q 2104.521	SALVAGE PIPE CULVERT	LIN FT	62		62	
	2104.523	SALVAGE SIGN TYPE C	EACH	35		35	
④	2104.523	SALVAGE SIGN TYPE SPECIAL	EACH	11		11	
	N 2105.501	COMMON EXCAVATION	CU YD	54135 (P)		54135 (P)	
	N 2105.505	MUCK EXCAVATION	CU YD	48952		48952	
	N 2105.507	SUBGRADE EXCAVATION	CU YD	583		583	
	N 2105.522	SELECT GRANULAR BORROW (LV)	CU YD	37634		37634	
⑤	2130.501	WATER	M-GAL	300		300	
⑦	D 2211.503	AGGREGATE BASE (CV) CLASS-SA	CU YD	10050 (P)		10050 (P)	
	2232.501	MILL BITUMINOUS SURFACE	SQ YD	480		480	
⑥	I 0331.601	2" THICK BIT WEARING COURSE	SQ YD	1172		1172	
⑩	D 2340.508	TYPE 41 WEARING COURSE MIXTURE	TDN	4817		4817	
⑩	D 2340.510	TYPE 31 BINDER COURSE MIXTURE	TDN	5885		5885	
	D 2340.514	TYPE 31 BASE COURSE MIXTURE	TDN	4560		4560	
	D 2357.502	BITUMINOUS MATERIAL FOR TACK COAT	GAL	4699		4699	
	0412.602	MAIL BOX SUPPORT	EACH	32		32	
	2451.509	AGGREGATE BEDDING (LV)	CU YD	104		104	
	R 2501.511	15" CS PIPE CULVERT	LIN FT	475		475	
	R 2501.511	18" CS PIPE CULVERT	LIN FT	286		286	
	R 2501.511	24" RC PIPE CULVERT	LIN FT	180		180	
	R 2501.515	12" RC PIPE APRON	EACH	3		3	
	R 2501.515	15" RC PIPE APRON	EACH	2		2	
	R 2501.515	18" RC PIPE APRON	EACH	1		1	
	R 2501.515	21" RC PIPE APRON	EACH	1		1	
	R 2501.515	24" RC PIPE APRON	EACH	7		7	
	R 2501.567	15" CS SAFETY APRON AND GRATE DES 3128F	EACH	28		28	
	R 2501.569	18" CS SAFETY APRON AND GRATE DES 3128F	EACH	12		12	
	S 2503.541	12" RC PIPE SEWER DESIGN 3006	LIN FT	146		146	
	S 2503.541	15" RC PIPE SEWER DESIGN 3006	LIN FT	208		208	
	S 2503.541	18" RC PIPE SEWER DESIGN 3006	LIN FT	909		909	
	S 2503.541	21" RC PIPE SEWER DESIGN 3006	LIN FT	106		106	
	S 2503.541	24" RC PIPE SEWER DESIGN 3006	LIN FT	655		655	
	S 2506.501	CONSTRUCT DRAINAGE STRUCTURE DESIGN H	LIN FT	4.1		4.1	
	S 2506.501	CONSTRUCT DRAINAGE STRUCTURE DESIGN G	LIN FT	6.1		6.1	
	S 2506.501	CONSTRUCT DRAINAGE STRUCTURE DESIGN F	LIN FT	20.2		20.2	
	S 2506.516	CASTING ASSEMBLY	EACH	8		8	
	R-S 2511.507	GRouted RIPRAP	CU YD	29		29	
⑪	2521.501	4" CONCRETE WALK	SO FT	686		686	
⑪	M 2531.501	CONCRETE CURB AND GUTTER DESIGN B612	LIN FT	492		492	
	L 2535.501	BITUMINOUS CURB	LIN FT	2047		2047	
	H 0557.603	INSTALL FENCE	LIN FT	3698		3698	
	H 0557.603	TEMPORARY FENCING	LIN FT	2750		2750	
	0563.601	DETOUR SIGNING	LUMP SUM	1		1	
④	0564.602	INSTALL SIGN TYPE SPECIAL	EACH	11		11	
⑨	2573.501	BALE CHECK	EACH	1674		1674	
⑨	B 2573.503	SILT FENCE, PREASSEMBLED	LIN FT	3448		3448	
	J 2575.501	SEEDING	ACRE	14 (P)		14 (P)	
	J 2575.503	SEED MIXTURE 600	POUND	1049		1049	
	J 2575.505	SODDING TYPE LAWN & BOULEVARD	SQ YD	17720		17720	
	J 2575.511	MULCH MATERIAL TYPE 1	TON	28		28	
	J 2575.519	DISK ANCHORING	ACRE	14 (P)		14 (P)	
	J 2575.523	WOOD FIBER BLANKET TYPE REGULAR	SQ YD	457		457	
	J 2575.531	COMM FERT ANALYSIS 10-10-10	POUND	6995		6995	
	2580.501	TEMPORARY LANE MARKING	RD STA	335		335	

CHART	SHEET NO.	DESCRIPTION
A	3	CLEARING AND GRUBBING
B	3	SILT FENCE
C	3	RETAINING WALL REMOVAL
D	4	BITUMINOUS REMOVAL
E	4	SAVING BITUMINOUS PAVEMENT
F	4	SAVING CONCRETE PAVEMENT
G	4	BIT. FLUME REMOVAL
H	4	FENCE CONSTRUCTION
I	4	ENTRANCES REMOVAL AND CONSTRUCTION CHART
J	4	TURF ESTABLISHMENT
K	4	DRAINAGE STRUCTURE REMOVAL
L	4	BITUMINOUS CURB CONSTRUCTION
M	4	CONCRETE CURB CONSTRUCTION
N	6	EARTHWORK SUMMARY
O	6	BASE AND BITUMINOUS QUANTITIES CHART
P	7	BERM CONSTRUCTION LOCATION
Q	10	RIGHT TURN LANE AND BYPASS LOCATION
R	5	CULVERT TABULATION
S	5	STDRM SEWER TABULATION
T	5	DRAINAGE CASTING SCHEDULE
U	42	TRAFFIC CONTROL DEVICES

PLATE NO.	DESCRIPTION
3000 L	REINFORCED CONCRETE PIPE
3006 G	GASKET JOINT FOR R.C. PIPE
3014 J	REINFORCED CONCRETE PIPE ARCH
3100 G	CONCRETE APRON FOR REINFORCED CONCRETE PIPE
3110 G	CONCRETE APRON FOR REINFORCED CONCRETE PIPE-ARCH
3128 F	SAFETY APRON
3133 B	RIPRAP AT R.C.P. OULET
3145 E	CONCRETE PIPE TIES
4005 L	MANHOLE OR CATCH BASIN (DESIGN F)
4006 L	MANHOLE OR CATCH BASIN (DESIGN G AND DESIGN H)
4010 G	CONCRETE SHORT CONE & ADJUSTING RING
4020 G	MANHOLE OR CATCH BASIN COVER
4101 C	RING CASTING FOR MANHOLE OR CATCH BASIN
4110 E	COVER CASTING FOR MANHOLE
4126 F	CATCH BASIN FRAME CASTING
4140 D	SPECIAL GRATE CASTINGS FOR CATCH BASIN
4149 C	GRATE CASTING FOR CATCH BASIN
4161 F	CURB BOX CASTING FOR CATCH BASIN
4180 H	MANHOLE OR CATCH BASIN STEP
7065 C	BITUMINOUS CURB
7111 H	INSTALLATION & REINFORCEMENT OF CATCH BASIN CASTINGS
8000 L	STANDARD BARRICADES
9102 D	TURF ESTABLISHMENT AREAS (AT PIPE CULVERT ENDS)
9322 J	CHAIN LINK FENCE

2340	TYPE 41 PLANT MIXED WEARING COURSE AND BINDER COURSE BITUMINOUS MIXTURE 110 LBS./SQ.YD. PER 1" THICKNESS
2340	TYPE 31 PLANT MIXED BASE BITUMINOUS MIXTURE 110 LBS./SQ.YD. PER 1" THICKNESS
2357	BITUMINOUS MATERIAL FOR TACK 0.05 GALLONS PER SQ YD. PER LIFT APPLIED
2575	MULCH MATERIAL TYPE 1, 2 TONS PER ACRE
2575	COMMERCIAL FERTILIZER, ANALYSIS 10-10-10 500 LBS./ACRE ON ALL SEED AND SOD AREAS
2575	ROADSIDE SEEDING BASED ON HORIZONTAL MEASUREMENT +10% SEED MIXTURE NO. 600, 75LBS. PER ACRE

- NOTES
- ① INCLUDES ALL TYPES AND SIZES.
 - ② INCLUDES ALL BITUMINOUS PAVEMENTS IRREGARDLESS OF DEPTH AND WIDTH.
 - ③ INCLUDES ALL CONCRETE PAVEMENTS IRREGARDLESS OF DEPTH AND WIDTH.
 - ④ MUNICIPAL STREET SIGNS.
 - ⑤ FOR DUST CONTROL AS DIRECTED BY THE ENGINEER.
 - ⑥ FOR DRIVEWAY CONSTRUCTION SEE CHART 1
 - ⑦ INCLUDES QUANTITY FOR AGGREGATE APPROACHES AND ENTERANCES.
 - ⑧ FOR USE AT CULVERT ENDS.
 - ⑨ FOR TEMPORARY EROSION CONTROL AS SHOWN IN THE PLANS AND AS DIRECTED BY THE ENGINEER.
 - ⑩ INCLUDES QUANTITY FOR ADDITIONAL 1/4" TO DESIGN PAVEMENT THICKNESS.
 - ⑪ FOR MEDIAN CONSTRUCTION.

STATEMENT OF ESTIMATED QUANTITIES

CERTIFIED BY Walter M. ... P.E. REG NO. 20235 May 1 19 96 S.P. _____ S.A.P. _____ C.P. 93-04-60 Sheet No. 2 of 42 Sheets

REVISIONS	DATE	BY

FILE NAME: F:\930406\TAB-CHDVG.MW.04-30-96

CLEARING AND GRUBBING (A)

STATION	LOCATION	CLEARING TREE	GRUBBING TREE	ACRE	ACRE
21+99	50' LT	1			
22+06	35' LT	1			
22+07	47' LT	1			
22+09	54' LT	1			
22+23	29' LT	2			
22+55	35' LT	1			
22+62	34' LT	2			
23+04	46' LT	1			
24+04	30' LT	1			
24+10	42' LT	1			
24+11	55' LT	1			
24+21	42' LT	1			
24+22	29' LT	0			
24+43	43' LT	0			
24+48	28' LT	0			
24+53	52' LT	0			
24+71	29' LT	1			
25+00	35' LT	1			
25+00	48' LT	1			
25+00	55' LT	1			
25+05	37' LT	1			
25+13	40' LT	1			
25+21	34' LT	1			
25+31	33' LT	1			
25+99	31' LT	1			
26+02	39' LT	1			
26+38	40' LT	1			
26+84	37' LT	1			
27+05	42' LT	1			
27+05	57' LT	1			
27+06	47' LT	1			
27+54	59' RT	1			
28+17	28' LT	1			
28+30	47' LT	1			
28+44	59' LT	1			
28+50	28' LT	1			
28+51	53' LT	1			
28+54	34' LT	1			
28+59	53' LT	1			
28+61	38' LT	1			
28+72	37' LT	1			
28+82	38' LT	1			
28+83	58' LT	1			
28+86	49' LT	1			
28+98	52' LT	1			
29+08	37' LT	1			
29+14	48' LT	0			
29+15	57' LT	1			
29+20	56' LT	1			
29+21	41' LT	1			
29+21	41' LT	1			
29+26	40' LT	5			
29+27	46' LT	1			
29+30	37' LT	5			
29+38	41' LT	1			
29+47	36' LT	5			
29+55	36' LT	5			
29+59	36' LT	5			
29+64	37' LT	5			
30+19	54' LT	1			
30+23	38' LT	1			
30+24	39' LT	1			
30+37	39' LT	1			
30+47	34' LT	1			
30+59	45' LT	1			
30+61	46' LT	1			
31+63	30' LT	1			
32+40	25' LT	1			
32+64	58' LT	1			
32+64	46' LT	1			
32+65	51' LT	1			
32+69	53' LT	1			
35+73	44' RT	1			
35+92	35' RT	1			
36+00	34' RT	1			
36+52	34' RT	1			
36+54	34' RT	1			
36+70	34' RT	1			
40+78	42' RT	1			
41+49	36' RT	1			
41+68	58' LT	1			
43+36	53' RT	1			
43+75	55' RT	1			
44+08	58' RT	1			
46+71	56' RT	1			
47+27	56' RT	1			
47+45	59' RT	1			
47+62	60' RT	1			
48+10	59' RT	1			
48+44 - 49+18	41' -60' LT	0.10			0.10

CLEARING AND GRUBBING (A)

STATION	LOCATION	CLEARING TREE	GRUBBING TREE	ACRE	ACRE
48+51	59' RT	1			
50+54	40' LT	4			
51+03	47' LT	5			
51+13	39' LT	2			
51+43	40' LT	5			
51+76	41' RT	1			
51+88	34' RT	2			
51+88	47' RT	1			
52+41	26' LT	2			
55+87 - 56+74	38' -60' LT	0.10			0.10
55+94	33' LT	0			
62+05	43' RT	1			
62+19	36' RT	1			
62+31	33' RT	1			
62+34	32' RT	1			
62+35	32' RT	1			
62+37	30' RT	1			
62+43	33' RT	1			
62+49	31' RT	1			
62+49	36' RT	1			
62+53	35' RT	1			
62+53	33' RT	1			
62+55	32' RT	1			
62+57	32' RT	1			
62+58	32' RT	1			
62+66	32' RT	1			
62+69 - 63+84	37' -60' LT	0.10			0.10
62+76	33' RT	1			
64+70	57' LT	1			
65+24	31' RT	1			
65+26	33' RT	1			
65+29	33' RT	1			
65+46	32' RT	1			
65+84	31' RT	1			
65+88	34' RT	1			
66+78	45' LT	1			
67+60	36' LT	1			
67+79 - 69+21	37' -60' RT	0.15			0.15
68+00	35' LT	1			
68+08	54' LT	3			
71+56	32' RT	1			
72+23 - 74+32	35' -60' RT	0.15			0.15
72+57	52' LT	2			
72+92	51' LT	1			
73+36	23' RT	1			
74+48	47' LT	0			
74+66	35' RT	1			
74+86	53' RT	1			
75+26	42' RT	1			
75+43	32' RT	1			
75+74	36' RT	1			
75+92	33' RT	1			
75+96	38' RT	1			
76+12	34' RT	1			
76+12	57' RT	1			
76+14	32' RT	1			
76+16	33' RT	1			
76+17	38' RT	1			
76+97	44' LT	1			
77+08	60' RT	1			
78+01	49' RT	0			
78+02	55' RT	1			
78+04	39' RT	1			
78+08	44' RT	1			
78+09	47' RT	1			
78+09	51' RT	1			
78+93	31' RT	1			
79+12	45' LT	1			
79+14	41' LT	1			
79+33	40' LT	1			
79+73	43' LT	1			
79+76	29' LT	1			
79+76	53' LT	1			
79+83 - 80+08	32' -60' LT	0.05			0.05
80+45 - 81+27	40' -60' LT	0.10			0.10
81+28	40' LT	1			
81+74	32' LT	1			
84+61	25' RT	1			
85+07	28' RT	1			
86+99	36' LT	1			
87+20	37' LT	1			
87+85 - 91+03	27' -60' LT	0.50			0.50
91+11	31' LT	4			
91+19	48' LT	1			
91+20	47' LT	1			
91+20	35' LT	1			
91+20	30' LT	1			
91+23	56' LT	1			
91+24	32' LT	3			
91+25	27' LT	1			

CLEARING AND GRUBBING (A)

STATION	LOCATION	CLEARING TREE	GRUBBING TREE	ACRE	ACRE
91+30	37' LT	1			
91+30	31' LT	1			
91+34	37' LT	1			
91+34	31' LT	1			
91+44	28' LT	1			
91+46	29' LT	0			
91+52	30' LT	0			
91+53	33' LT	1			
91+56	54' LT	1			
91+58	40' LT	2			
91+63	44' LT	1			
91+63	59' LT	1			
91+63	38' LT	1			
91+65	36' LT	2			
91+69	38' LT	1			
91+70	23' LT	1			
91+72	39' LT	1			
91+75	39' LT	1			
91+79	43' LT	1			
91+96	47' LT	1			
92+04	43' LT	1			
92+04	47' LT	1			
92+05	36' LT	1			
92+08	52' LT	1			
92+12	29' LT	1			
92+11	32' LT	1			
92+13	42' LT	1			
92+25	36' LT	1			
92+40	45' LT	1			
92+46	40' LT	0			
92+48	43' LT	1			
92+50	27' LT	1			
92+50	57' LT	1			
92+52	51' LT	1			
92+55	46' LT	1			
92+57	60' LT	1			
92+60	51' LT	1			
92+69	33' LT	1			
92+80	32' LT	1			
92+88	59' LT	1			
92+88	40' LT	1			
92+90	46' LT	1			
93+22	34' LT	1			
93+29	39' LT	1			
93+50 - 101+35	24' -60' LT	1.00			1.00
95+60	47' RT	1			
95+81	45' RT	1			
95+96	37' RT	1			
95+98	49' RT	1			
96+18	44' RT	1			
96+38	49' RT	1			
96+59	46' RT	1			
96+79	40' RT	1			
97+34	39' RT	1			
98+80 - 99+28	39' -60' RT	0.05			0.05
100+82	42' RT	1			
101+11	57' RT	1			
101+78	38' RT	1			
101+78	38' RT	1			
101+78	51' RT	1			
101+79	58' RT	1			
102+52	55' LT	1			
102+62	46' LT	4			
102+77	33' LT	1			
102+84	32' LT	1			
102+91	53' RT	0			
102+91	59' RT	0			
102+94	33' RT	1			
102+94	56' RT	0			
102+94	49' RT	0			
102+97	58' RT	0			
102+97	40' RT	1			
102+97	53' RT	1			
103+02	29' RT	1			
103+05	42' RT	1			
103+30	50' RT	1			
103+62	51' RT	1			
103+76	51' RT	1			
103+90	51' RT	4			
104+09	52' RT	1			
104+65	27' RT	1			
104+66	31' RT	1			
104+68	29' RT	1			
105+60 - 105+81	24' -60' RT	0.05			0.05
105+83	34' RT	1			
105+90	34' RT	1			
105+96	34' RT	1			
106+04	32' RT	1			
106+08	34' RT	1			
106+14	34' RT	1			

CLEARING AND GRUBBING (A)

STATION	LOCATION	CLEARING TREE	GRUBBING TREE	ACRE	ACRE
106+20	34' RT	1			
106+23 - 108+26	28' -44' LT	0.15			0.15
106+26	34' RT				

BITUMINOUS REMOVAL (D)			
STATION-STATION	LOCATION	DESCRIPTION	SQ. YD.
10+00 - 16+40	RT	MAINLINE	1758
11+90 - 12+85	20' LT	RIGHT TURN LANE	27
21+15 - 29+91	12' LT & RT	MAINLINE	2794
21+67	62' RT	DAVENPORT ST.	178
29+91 - 34+76	12' LT & RT	MAINLINE	1705
34+76 - 39+00	12' LT & RT	MAINLINE	1091
35+20	54' RT	HASTINGS ST.	145
35+38	50' LT	HASTINGS ST.	145
39+00 - 45+85	12' LT & RT	MAINLINE	1659
45+85 - 52+39	12' LT & RT	MAINLINE	1570
52+39 - 60+00	12' LT & RT	MAINLINE	1787
60+00 - 67+00	12' LT & RT	MAINLINE	1700
67+00 - 74+67	12' LT & RT	MAINLINE	1782
74+64 - 82+00	12' LT & RT	MAINLINE	1722
75+05	52' LT	TACONITE ST.	144
80+19	50' RT	NEW STREET	164
82+00 - 87+26	12' LT & RT	MAINLINE	1297
87+26 - 95+00	12' LT & RT	MAINLINE	1881
87+87	72' RT	CO. RD. #61	277
95+00 - 101+00	12' LT & RT	MAINLINE	1421
101+00 - 110+00	12' LT & RT	MAINLINE	2111
110+00 - 118+00	12' LT & RT	MAINLINE	1833
118+00 - 125+00	12' LT & RT	MAINLINE	1653
125+00 - 129+45	12' LT & RT	MAINLINE	1514
21+45 - 129+45	LT & RT	ENTRANCES	654
TOTAL			31012

SAWING BITUMINOUS PAVEMENT (E)			
STATION	LOCATION	REMARKS	LIN. FT.
10+00	RT C/L	COUNTY ROAD 60	63
10+00 - 12+50	3' LT C/L		261
11+90 - 12+85	20' LT C/L		119
12+50 - 16+40	RT C/L		410
21+15	22' LT & RT	COUNTY ROAD 60	44
21+67	62' RT	DAVENPORT STREET	30
22+82	58' LT	ENTRANCE #1616	12
24+86	58' LT	ENTRANCE #1619	12
26+55	58' LT	ENTRANCE #1729	20
30+30	45' RT	ELEMENTARY SCHOOL	28
31+38	58' LT	ENTRANCE #1729	18
31+79	45' LT	ELEMENTARY SCHOOL	28
35+38	50' LT	HASTINGS STREET	28
35+20	54' RT	HASTINGS STREET	30
72+20	58' RT	ENTRANCE #2350	12
75+05	52' LT	TACONITE STREET	12
80+19	50' RT	NEW STREET	30
87+87	72' LT	COUNTY ROAD 61	20
91+99	58' RT	ENTRANCE #2650	28
128+13	70' LT	EAST LAKE NETTA DRIVE	26
129+45	22' LT & RT	COUNTY ROAD 60	44
TOTAL			1275

SAWING CONCRETE PAVEMENT (F)			
STATION	LOCATION	REMARKS	LIN. FT.
25+72	58' LT		12
67+47	58' LT		14
77+40	58' RT		12
TOTAL			38

BITUMINOUS FLUME REMOVAL (G)			
STATION	LOCATION	REMARKS	LIN. FT.
74+70	22' RT	WEST OF TACONITE ST.	1
75+30	27' LT	EAST OF TACONITE ST.	1
80+03	36' RT	WEST OF NEW STREET	1
80+35	38' RT	EAST OF NEW STREET	1
TOTAL			4

FENCE CONSTRUCTION (H)						
STATION-STATION	LOCATION	SALVAGE	REMOVE	INSTALL	TEMPORARY	REMARKS
23+01 - DUT	23' - 60' LT		37			WOOD FENCE
32+01 - 34+78	57' RT	277		277		CHAIN LINK
38+19 - DUT	35' - 60' RT		25			CHAIN LINK
38+19 - 39+40	35' RT	121		121		CHAIN LINK
39+40 - DUT	35' - 60' LT		25			CHAIN LINK
48+39 - DUT	35' - 60' RT		25			WIRE FENCE
48+39 - 52+34	29' RT	395		395		WIRE FENCE
48+39 - 71+40	RT				2301	
52+29 - DUT	28' - 60' RT		32			WIRE FENCE
50+48 - 54+97	44' LT	449		449	449	WIRE FENCE
50+48 - 50+63	44' - 60' LT	45		45		WIRE FENCE
52+67 - 52+69	28' - 59' RT		28			WIRE FENCE
52+67 - 64+08	28' RT	1142		1142		WIRE FENCE
64+33 - 74+28	31' - 41' RT	995		995		WIRE FENCE
66+09 - 66+11	39' - 47' LT		10			WIRE FENCE
66+11 - 67+35	34' - 39' LT	124		124		WIRE FENCE
74+29 - DUT	41' - 60' RT		19			WIRE FENCE
114+55 - 114+75	33' - 40' RT	20		20		WOOD FENCE
114+71 - DUT	33' - 60' RT		27			WOOD FENCE
114+90 - 116+20	33' RT	130		130		WOOD FENCE
116+20 - DUT	33' - 60' RT		27			WOOD FENCE
TOTALS		3698	255	3698	2750	

ENTRANCES REMOVAL AND CONSTRUCTION CHART (I)														
STATION	ADDRESS	LOCATION	DESCRIPTION	REMOVAL LENGTH	INPLACE WIDTH	REPLACEMENT		REMOVAL			REPLACEMENT		CONC. APRON SQ. YD.	BIT APRON SQ. YD.
						LENGTH	WIDTH	CONC. SQ. YD.	BIT SQ. YD.	CONC. SQ. YD.	BIT SQ. YD.	CL-5A CU. YD.		
22+82	1609	58' LT	BITUMINOUS	44	12	35	12							
23+79	1616	58' LT	GRAVEL	42	17	38	17							
24+86	1619	58' LT	BITUMINOUS	42	12	35	12							
25+72	1639	55' LT	CONCRETE	43	12	36	12	57	56	43	41		8	
26+55	1647	58' LT	BITUMINOUS	43	20	36	20							
27+62	1659	58' LT	GRAVEL	43	20	38	20							
28+96	1711	58' LT	GRAVEL	42	12	38	12							
29+82	1719	58' LT	GRAVEL	43	14	40	14							
30+30	SCHOOL	45' RT	BITUMINOUS	45	31	30	28		155		136			
31+38	1729	58' LT	BITUMINOUS	45	18	38	18		90		68			
31+79	SCHOOL	45' RT	BITUMINOUS	25	28	25	28		78		121			10
32+19	1741	58' LT	GRAVEL	44	16	38	16							
48+27	16245	58' RT	GRAVEL	44	12	38	12							9
50+33	2045	58' LT	GRAVEL	52	12	56	12							
52+53	LAZY-U	58' RT	GRAVEL	44	17	38	17							
64+08		47' LT	GRAVEL	38	28	38	28							
64+18	2202	47' RT	GRAVEL	45	12	38	12							
67+47	2259	58' LT	CONCRETE	40	14	38	14	62		53		8		
72+20	2350	58' RT	BITUMINOUS	45	12	38	12							
73+08		47' LT	GRAVEL	53	12	38	12							
74+51	CAMP	46' RT	GRAVEL	43	18	38	18							
76+56	2415	58' LT	GRAVEL	49	14	38	14							10
77+40	2424	58' RT	GRAV/CONC	42	12	40	16	25		64		9		8
78+84	2427	59' LT	GRAVEL	48	12	38	12							
80+20	2441	58' LT	GRAVEL	48	18	35	18							
91+88	2635	58' LT	GRAVEL	43	12	38	12							
91+99	2650	58' RT	BITUMINOUS	46	12	38	12		61		62			8
93+13	2653	58' LT	GRAVEL	43	12	38	12							
97+00	2722	58' RT	GRAVEL	47	18	38	18							
102+16	2807	46' LT	GRAVEL	33	20	38	20							
102+39	2807	58' LT	GRAVEL	42	18	38	18							
103+63	2821	58' LT	GRAVEL	42	12	38	12							
104+46	2824	58' RT	GRAVEL	46	14	38	14							
105+88		58' LT	GRAVEL	42	12	38	12							
106+84	2846	58' RT	GRAVEL	46	12	38	12							
110+33	2914	58' RT	GRAVEL	46	12	38	12							
113+33	2954	58' RT	GRAVEL	46	12	38	12							
114+84	16250	58' RT	GRAVEL	46	12	38	12							
TOTAL								144	654	160	586	204	25	122

TURF ESTABLISHMENT (J)							
STA. TO STA.	LOCATION	SOD SQ. YD.	SEEDING ACRES	SEED POUND	MULCH TONS	FIBER SQ. YD.	FERTILIZER POUND
10+00 - 16+40	RT		0.44	33	0.9		220
21+85 - 32+68	LT	3819					
25+10	RT	65					
27+34 - 37+14	RT	3359					
48+46 - 48+49	RT	886					
63+60 - 64+52	LT	184					
66+07 - 67+86	LT	678					
72+15	RT	40					
73+11	LT	40					
75+18 - 80+44	LT	2036					
75+72 - 78+40	RT	942					
87+23	RT	142					
88+51	RT	156					
90+33 - 93+77	LT	1123					
91+19 - 97+86	RT	2558					
101+25 - 103+93	LT	870					
101+73	RT	109					
102+82	RT	102					
104+46	RT	36					
105+88	LT	36					
106+85	RT	40					
113+29	RT	40					
114+83	RT	36					
116+51	RT	208					
125+02	LT & RT	215					
21+15 - 129+45	LT & RT		12.95	971	25.9		6475
00+60 - 06+80	DRAIN EASMT		0.60	45	1.2		300
TOTAL		17720	13.99	1049	28.0		6995

BITUMINOUS CURB CONSTRUCTION (L)			
STATION - STATION	LOCATION	REMARKS	LIN. FT.
21+85 - 22+76	20' LT		123
22+86 - 23+70	20' LT		103
23+88 - 24+80	20' LT		112
24+92 - 25+66	20' LT		95
25+77 - 26+45	20' LT		88
26+64 - 27+53	20' LT		108
27+71 - 28+90	20' LT		139
37+10 - 39+00	20' RT		190
65+50 - 67+34	20' LT		188
74+75 - 77+27	20' RT		252
75+18 - 76+42	20' LT		142
90+33 - 91+84	20' LT		160
90+50 - 91+90	20' RT		148
91+93 - 93+08	20' LT		134
93+20 - 93+75	20' LT		65
TOTAL			2047

CONCRETE CURB CONSTRUCTION (M)			
STATION - STATION	LOCATION	REMARKS	LIN. FT.
10+06 - 12+46	0' - 4' RT	B-612 (SLOPE OUT)	492
TOTAL			492

DRAINAGE STRUCTURE REMOVAL (K)			
STATION	LOCATION	REMARKS	EACH
27+60	33' RT	C.B. WEST OF EVELETH ST. NE.	1
28+06	34' RT	C.B. EAST OF EVELETH ST. NE.	1
TOTAL			2

TABULATION CHARTS

- BITUMINOUS REMOVAL
- SAWING BITUMINOUS PAVEMENT
- SAWING CONCRETE PAVEMENT
- BITUMINOUS FLUME REMOVAL
- FENCE CONSTRUCTION
- ENTRANCES CONSTRUCTION CHART
- TURF ESTABLISHMENT
- C.B. STRUCTURE REMOVAL
- BITUMINOUS CURB CONSTRUCTION
- CONCRETE CURB CONSTRUCTION

REVISIONS BY DATE
 FILE NAME: P:\9304\TAB-CH.DWG (IN: 04-30-96)

CULVERT TABULATION														RIPRAP OUTLETS				
STATION	LOC	INPLACE	REMARKS	SODDING CULV. PIPE		REMOVE CULV. PIPE		SALVAGE CULV. PIPE		INSTALL CULV. PIPE		FURNISH & INSTALL CULVERT				CU. YD.		
				SO. YD.	LN. FT.	LN. FT.	APR.	LN. FT.	APR.	LN. FT.	APR.	15' CMP	18' CMP	24' RCP	APR.			
21+68	44 RT	18' CMP	DAVENPORT ST.		72											5.8		
27+84	35 RT	15' CMP	EVELTH ST. N.		82								48	2				
30+29	40 RT	12' CMP	SCHOOL ENT.		46					48	2							
31+79	41 RT	12' CMP	SCHOOL ENT.		46					46	2							
35+20	35 RT		HASTINGS ST. NE.									50	2					
46+23	49 RT		KENYON ST. NE.									62	2					
48+27	41 RT		ENT. #16245							30	2							
64+08	39 LT		QUAMBA ST. NE.									50	2					
67+41		15' CMP	ENT. #2259		30													
73+08	35 LT	15' CMP	ENT.		30					20	2							
75+05		18' CMP	TACONITE ST. NE.		64													
78+84	35 LT	15' CMP	ENT. #2427		30					28	2							
80+19	35 RT		NEW STREET					66	2			44	2					
80+20	35 LT		ENT. #2441							34	2							
87+87	43 RT		CD. RD. 61										62	2				
97+00	36 RT		ENT. #2722							28	2							
102+28	36 LT		ENT. #2807 (DBL ENT.)							54	2							
103+63	35 LT		ENT. #2821							18	2							
104+46	39 RT		ENT. #2824							44	2							
105+88	35 LT		ENT.							26	2							
106+84	33 RT		ENT. #2846							35	2							
110+33	33 RT		ENT. #2914							22	2							
113+33	37 RT		ENT. #2954							22	2							
114+84	37 RT		ENT. #16250							20	2							
116+51	37 RT		GUADALCANA									32	2					
125+03	LT & RT	18' CMP	X-ROAD		50									58	2	5.8		
TOTAL					450			66	2			475	28	286	12	180	6	11.6

① SAFETY APRON

DRAINAGE CASTING SCHEDULE				
ASS'Y TYPE	NO REQ'D	FRAME CASTING	GRATE CASTING	CURB BOX CASTING
A	3	801	810	821
B	4	700-7	720	
C	1	700-7	715	
TOTAL	8			

STORM SEWER TABULATION														RIPRAP				
STRUCT.	STATION	LOC	REMARKS	MH/CB	DESIGN	PAY HT. LIN. FT.	TOP OF CASTING ELEVATION	OUTLET ELEVATION	FURNISH & INSTALL CULVERT					APRON EACH	DRAINS TO	GRADE IN%	CU. YD.	
									CASTING ASSEMBLY	12' RCP LIN. FT.	15' RCP LIN. FT.	18' RCP LIN. FT.	21' RCP LIN. FT.					24' RCP LIN. FT.
101	25+50	20.9 LT		CB	H	1.9	907.24	905.15	A	42								
102	25+50	27.5 RT	12' RC APRON OUTLET	OUTLET	APRON			905.00						1	DITCH	0.33	2.1	
103	29+30	20.9 LT		CB	H	2.2	908.76	906.41	A	42								
104	29+30	29.1 RT	12' RC APRON OUTLET	OUTLET	APRON			906.14						1	DITCH	0.56	2.1	
105	32+65	28.6 LT	12' RC APRON OUTLET	INLET	APRON			907.43		12				1	106	0.69		
106	32+65	20.9 LT		CB	G	2.6	910.10	907.32	A	50					107	0.32		
107	32+65	35.4 RT	12' RC APRON OUTLET	OUTLET	APRON			907.14						1	DITCH	0.32	2.1	
201	45+87	38.4 LT	15' RC APRON INLET	INLET	APRON			906.56				142		1	203	0.35		
202	47+35	40.0 RT	12' RC APRON INLET	INLET	APRON			906.04				66		1	203	0.30		
203	47+35	33.0 LT		MH	G	3.5	909.30	905.63	B				423		204	0.40		
204	51+64	33.0 LT		MH	F	6.9	910.66	903.91	B				480		205	0.40		
205	56+50	47.0 LT	18' RC APRON OUTLET	OUTLET	APRON			901.97						1	SWAMP	0.40	3.6	
301	101+62	41.0 RT	18' RC APRON INLET	INLET	APRON			905.03				106		1		0.33		
302	100+50	29.8 LT		INLET	APRON			905.62						1	303	1.65		
303	100+50	28.2 RT		MH	F	3.7	908.22	904.66	B				265		304	0.33		
304	97+85+0+32.7	32.7 RT	ESMT. C/L STA. 0+32.7	MH	F	5.4	909.02	903.79	B				328		305	0.40		
305	3+60	C/L	EASEMENT C/L	MH	F	4.2	906.60	902.48	C				10		306	0.40		
306	3+76	C/L	EASEMENT C/L	OUTLET	APRON			902.42						1	SWAMP	0.40	3.6	
TOTAL						30.4			8	146	208	909	106	655	10			13.5

TABULATION CHARTS

CULVERT TABULATION
STORM SEWER TABULATION
DRAINAGE CASTING SCHEDULE

REVISIONS	DATE	BY

EARTHWORK SUMMARY (N)

SOILS AND CONSTRUCTION NOTES:

EXCAVATION

COMMON EXCAVATION	58,833	CU. YD.	}	REGULAR	36,838	CU. YD.	①
MUCK EXCAVATION	48,952	CU. YD.		SUBCUT	11,833	CU. YD.	
SUBGRADE EXCAVATION	583	CU. YD.		TOPSOIL	10,162	CU. YD.	

EMBANKMENT (CV)

SELECT GRANULAR	57,498	CU. YD.
SUBCUT	11,833	CU. YD.
TOPSOIL	7,257	CU. YD.
MUCK	3,408	CU. YD.

BALANCE

TOPSOIL
 TOPSOIL DRESSING (CV) - [TOPSOIL STRIPPING (EV) x SHRINKAGE FACTOR] = EXCESS(-) OR SHORTAGE(+)
 $7,257 - (10,162 \times 0.85) = -1,380$ CU. YD. EXCESS

SELECT GRANULAR BORROW
 SEL SGRAN(CV)+SUBCUT - [REGULAR EXCAVATION (EV) x SHRINKAGE FACTOR] - [SUBCUT EXCAVATION x SHRINKAGE FACTOR] = EXCESS(-) OR SHORTAGE(+)
 $57,498+11,833 - [(36,838 - 4,698) \times 0.85] - (11,833 \times 0.90) = 31,362$ CU. YD. BORROW
 BORROW = (CV) x SWELL FACTOR = $31,362 \times 1.2 = 37,634$ CU. YD. (LV)

MUCK
 MUCK EMBANKMENT (CV) - [MUCK EXCAVATION (EV) x SHRINKAGE FACTOR] = EXCESS(-) OR SHORTAGE(+)
 $3,408 - (48,952 \times 0.85) = -38,201$ CU. YD. EXCESS

SOIL FACTORS:

- (1) REGULAR GRADING AND TOPSOIL DRESSING (EV TO CV): 85% SHRINKAGE
- (2) SUBCUT COMPACTION (EV TO CV): 90% SHRINKAGE
- (3) SELECT GRANULAR BORROW (CV TO LV): 120% SWELL
- (4) MUCK EXCAVATION (EV TO CV): 60% SHRINKAGE

① INCLUDES 4,698 CU. YD. CONCRETE AND BITUMINOUS REMOVAL. CONCRETE AND BITUMINOUS PAVEMENT REMOVALS WILL BE PAID UNDER ITEM 2104

1. TOP OF GRADING GRADE IS DEFINED AS THE BOTTOM OF THE AGGREGATE BASE.
2. IN FILL AREAS, THE SUBGRADE SHALL BE CONSTRUCTED WITH SELECTED GRADING MATERIAL.
3. SELECTED GRADING MATERIALS SHALL CONSIST OF SELECT GRANULAR MATERIALS.
4. GRANULAR MATERIAL, REGARDLESS OF SOURCE, SHALL MEET THE REQUIREMENTS OF SPEC. 3149.2B.
5. COMPACTION OF THE GRADING PORTION OF THIS PROJECT SHALL BE BY THE "QUALITY COMPACTION METHOD" WITH THE EXCEPTION OF CULVERT AND STORM SEWER TRENCHES WHICH SHALL BE COMPACTED BY THE "SPECIFIED DENSITY METHOD".
6. TEST ROLLING WILL NOT BE REQUIRED.
7. BITUMINOUS OR CONCRETE ITEMS REMOVED BY CONSTRUCTION SHALL BECOME THE PROPERTY OF THE CONTRACTOR AND SHALL BE EITHER RECYCLED OR DISPOSED OF IN ACCORDANCE WITH THE REQUIREMENTS OF 2104.3C3 WITH NO DIRECT COMPENSATION MADE THEREFORE.
8. DISPOSITION OF EXCESS EXCAVATED MATERIAL SHALL BE IN ACCORDANCE WITH THE REQUIREMENTS OF 2105.3D WITH NO DIRECT COMPENSATION THEREFORE.
9. WHERE MATCHING INTO THE INPLACE ROADWAY AT THE ENDS OF CONSTRUCTION, CUT VERTICALLY TO THE TOP OF THE GRADING GRADE, AND THEN AT A 20:1 TAPER TO THE BOTTOM OF THE RECOMMENDED SUBGRADE EXCAVATION.
10. WHERE CONNECTING NEW SURFACING TO AN INPLACE PAVEMENT, THE EXCAVATION SHALL BE BACKFILLED PROMPTLY TO AVOID UNDERMINING THE INPLACE PAVEMENT.
11. USE TACK COAT BETWEEN ALL BITUMINOUS MIXTURES PRIOR TO PLACING BITUMINOUS MIXTURES AND PRIOR TO PLACING ANY BITUMINOUS MIXTURES ON EXISTING CONCRETE OR BITUMINOUS SURFACES. THE BITUMINOUS TACK COAT MATERIAL SHALL BE APPLIED AT UNIFORM RATE OF 0.03 TO 0.05 GALLONS PER SQUARE YARD BETWEEN BITUMINOUS LAYERS. THE APPLICATION RATES ARE FOR UNDILUTED EMULSION (AS SUPPLIED FROM THE REFINERY); ASPHALT EMULSION MAY BE FURTHER DILUTED IN THE FIELD IN ACCORDANCE WITH SPEC. 2357.
12. COMPACTION OF ALL OF THE BITUMINOUS COURSES SHALL BE BY THE "MODIFIED SPECIFIED DENSITY METHOD".
13. COMPACTION OF THE AGGREGATE BASE LAYERS SHALL BE BY THE "SPECIFIED DENSITY METHOD".
14. PLACE MINIMUM 4 INCHES TOPSOIL OR SLOPE DRESSING ON ALL AREAS DISTURBED BY CONSTRUCTION AND SCHEDULED FOR PERMANENT TURF ESTABLISHMENT FERTILIZE WITH COMMERCIAL FERTILIZER, ANALYSIS 10-10-10, AT A RATE OF 500 POUND PER ACRE.
15. USE MIXTURE 600 SEED AND TYPE 1 MULCH IN AREAS TO BE SEEDDED.
16. SOD ALL DISTURBED LAWNS.
17. ALL SOD UTILIZED WITHIN THE PROJECT LIMITS SHALL MEET THE REQUIREMENTS OF SPEC 3878.2A (LAWN AND BOULEVARD SOD).
18. ORGANIC AND NONGRANULAR EXCAVATED MATERIAL MAY BE USED IN EMBANKMENT CONSTRUCTION IN AREAS OUTSIDE OF A 1 1/2:1 SLOPE FROM THE BACK OF CURB, OR GRADING P.I.
19. BITUMINOUS REMOVAL QUANTITY BASED ON SQUARE YARDS REMOVED. IN PLACE SURFACE ASSUMED TO BE 5-1/2 INCH IN DEPTH. CONTRACTOR SHALL INVESTIGATE AND MAKE OWN DETERMINATION OF ACTUAL PAVEMENT DEPTH.
20. ALL SILT FENCING AS SHOWN IN THE PLANS SHALL BE IN PLACE PRIOR TO THE COMMENCEMENT OF GRADING OPERATIONS.
21. A DOUBLE ROW OF BALE CHECKS SHALL BE INSTALLED TO PROTECT THE DNR PROTECTED WATERS AND WETLAND "F", BOTH NORTH AND SOUTH OF THE ROAD.
22. PERMANENT DITCH CHECKS TO SERVE AS SEDIMENTATION BASINS SHALL BE CONSTRUCTED IN DITCH INLETS INTO THE DNR PROTECTED WATERS AND WETLANDS "F" AT LOCATIONS TO BE DETERMINED BY THE ENGINEER. THIS WORK SHALL BE CONSIDERED INCIDENTAL WITH NO DIRECT PAYMENT MADE THEREFORE.
23. PARCELS 1, 2, 4, 9 AND 10 HAVE SEPTIC SYSTEMS AND DRAIN FIELDS WHICH WILL BE WITHIN THE NEW RIGHT-OF-WAY. CARE SHALL BE EXERCISED WHEN WORKING ON OR NEAR THESE SYSTEMS. SPECIFIC CONDITIONS ARE AS FOLLOWS:
 - A. ONLY EQUIPMENT WITH TRACKS SHOULD BE USED IN THE VICINITY OF DRAIN FIELDS SO AS NOT TO COMPACT SOILS.
 - B. TREES SCHEDULED FOR CLEARING AND GRUBBING IN OR AROUND A SEPTIC SYSTEM SHALL BE CUT AND STUMPS GROUND DOWN. TOTAL STUMP AND ROOT REMOVAL COULD AFFECT DRAIN FIELD OPERATIONS.
 - C. NO EQUIPMENT OF ANY KIND SHALL BE ALLOWED 27' NORTH OF CENTERLINE ALONG PARCEL 2.

BASE AND BITUMINOUS QUANTITIES CHART (D)

STATION - STATION	LOCATION	DESCRIPTION	BIT. SURFACE CONSTRUCTION		BIT. WEAR		BIT. BINDER		BIT. BASE		BITUMINOUS TACK COAT		AGGREGATE BASE CL-5A	
			SO. YD.	DEPTH	TON	DEPTH	TON	DEPTH	TON	DEPTH	TON	GALLON	DEPTH	CU. YD.
10+00 - 16+40	RT	MAINLINE	1930	1.5'	159	1.5'	186	2'	239	193	5'	306		
11+90 - 12+84	LT	SHOULDER WIDENING	49	1.5'	4	1.5'	5			2	6'	13		
21+15 - 129+45	12' LT & RT	MAINLINE	28880	1.5'	2383	1.5'	2826	2'	3872	2948	5'	4011		
21+15 - 21+85	20' LT	SHOULDER	62	1.5'	5	1.5'	6			3	5'	12		
21+15 - 37+10	20' RT	SHOULDER	1418	1.5'	117	1.5'	145			71	5'	285		
21+15 - 86+13	20' LT	SHOULDER	5776	1.5'	477	1.5'	591			289	5'	1160		
21+85 - 28+90	20' LT	BERM SHOULDER	627	1.5'	59	1.5'	73			36	5'	124		
28+90 - 30+44	20' LT	SHOULDER	137	1.5'	11	1.5'	14			7	5'	27		
30+44 - 35+06	24' RT	RIGHT TURN LANE	616	1.5'	51	1.5'	62	2'	83	64	5'	105		
35+06 - 37+10	20' RT	SHOULDER	181	1.5'	15	1.5'	19			9	5'	36		
37+10 - 39+00	20' RT	BERM SHOULDER	178	1.5'	17	1.5'	21			10	5'	35		
39+00 - 52+59	20' RT	SHOULDER	1208	1.5'	100	1.5'	124			60	5'	243		
50+23 - 56+55	20' LT	SHOULDER	562	1.5'	46	1.5'	57			28	5'	113		
52+59 - 57+00	20' RT	BERM SHOULDER	392	1.5'	37	1.5'	46			22	5'	78		
56+55 - 66+50	20' LT	SHOULDER	884	1.5'	73	1.5'	90			44	5'	178		
57+00 - 74+59	20' RT	SHOULDER	1564	1.5'	129	1.5'	160			78	5'	314		
65+50 - 67+36	20' LT	BERM SHOULDER	76	1.5'	8	1.5'	9			4	5'	15		
67+36 - 75+18	20' LT	SHOULDER	695	1.5'	57	1.5'	71			35	5'	140		
74+59 - 77+29	20' RT	BERM SHOULDER	240	1.5'	23	1.5'	28			14	5'	48		
75+18 - 76+49	20' LT	BERM SHOULDER	116	1.5'	11	1.5'	14			7	5'	23		
76+49 - 84+23	20' LT	SHOULDER	688	1.5'	57	1.5'	70			34	5'	138		
77+29 - 82+93	20' RT	SHOULDER	501	1.5'	41	1.5'	51			25	5'	101		
82+93 - 88+51	24' RT	RIGHT TURN LANE	744	1.5'	61	1.5'	75	2'	100	78	5'	127		
84+23 - 91+93	24' LT	BYPASS LANE	1027	1.5'	85	1.5'	103	2'	138	107	5'	175		
88+51 - 90+50	20' RT	SHOULDER	177	1.5'	15	1.5'	18			9	5'	36		
91+93 - 93+75	20' LT	BERM SHOULDER	162	1.5'	17	1.5'	19			9	5'	32		
90+50 - 91+90	20' RT	BERM SHOULDER	124	1.5'	12	1.5'	15			7	5'	25		
91+90 - 123+98	20' RT	SHOULDER	2852	1.5'	235	1.5'	292			143	5'	573		
93+75 - 129+45	20' LT	SHOULDER	3173	1.5'	262	1.5'	325			159	5'	637		
123+98 - 129+45	20' RT	BYPASS LANE	729	1.5'	60	1.5'	73	2'	98	76	5'	124		
21+67	50' RT	DAVENPORT ST	139	1.5'	11	1.5'	14			7	5'	49		
21+70	50' LT	DAVENPORT ST	139	1.5'	11	1.5'	14			7	5'	49		
27+83	50' RT	EVELETH ST	129	1.5'	11	1.5'	13			7	5'	46		
35+20	50' RT	HASTINGS ST	112	1.5'	9	1.5'	11			6	5'	40		
35+38	50' LT	HASTINGS ST	132	1.5'	11	1.5'	13			7	5'	47		
46+23	50' LT	KENYON ST	122	1.5'	10	1.5'	12			6	5'	44		
46+25	50' RT	KENYON ST	115	1.5'	10	1.5'	12			6	5'	41		
50+11	50' LT	STREET APPRACH	116	1.5'	10	1.5'	12			6	5'	42		
64+08	50' LT	QUAMBA ST	132	1.5'	11	1.5'	13			7	5'	47		
75+05	50' LT	TACONITE ST	139	1.5'	11	1.5'	14			7	5'	48		
80+19	50' RT	NEW STREET	143	1.5'	12	1.5'	14			7	5'	51		
87+87	74' RT	COUNTY ROAD 61	275	1.5'	23	1.5'	27	2'	31	28	5'	94		
101+31	50' RT	BATAAN ST	119	1.5'	10	1.5'	12			6	5'	43		
116+51	50' RT	GUADALCANA ST	122	1.5'	10	1.5'	12			6	5'	44		
128+16	72' LT	E LAKE NETTA DR	255	1.5'	21	1.5'	25			13	5'	88		
21+15 - 129+45	20' LT & RT	1.5' ENT. KICKOUT	120	1.5'	10	1.5'	12				5'	43		
			58075		4817		5885		4560	4699		10050		

① INCLUDES AN ADDITIONAL 1/4" THICKNESS TO THE PLANNED QUANTITY.

TABULATION CHARTS, EARTHWORK SUMMARY, CONSTRUCTION NOTES

REVISIONS BY DATE

FILE NAME: P:\930460\TAB-CH.DWG PK. (04-30-96)

TYPICAL UNPAVED ENTRANCE

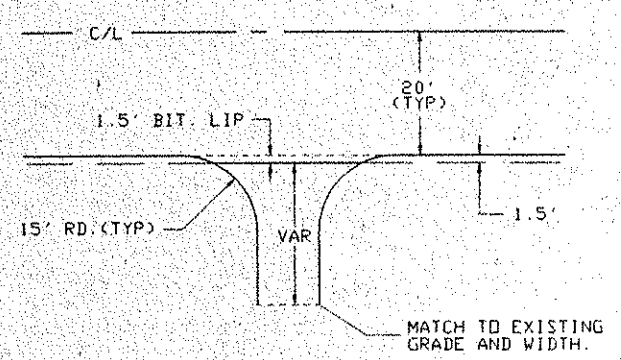

NOTE: ENTRANCE INSLOPE SHALL BE 6:1.

BITUMINOUS APRON DETAIL

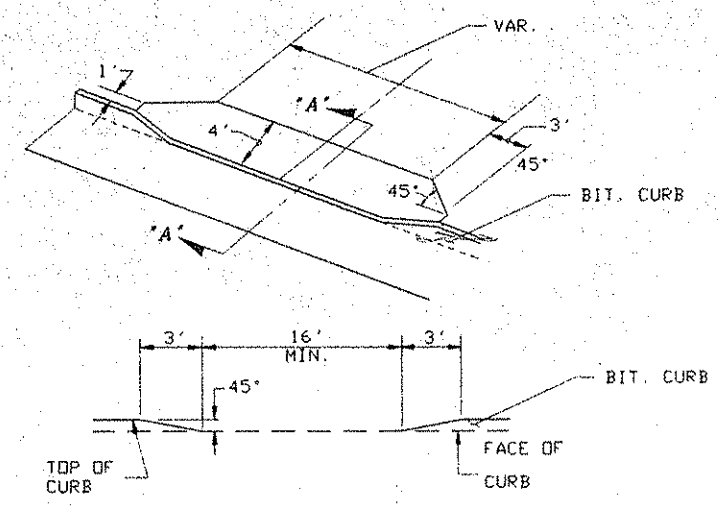

SECTION 'A'-'A'

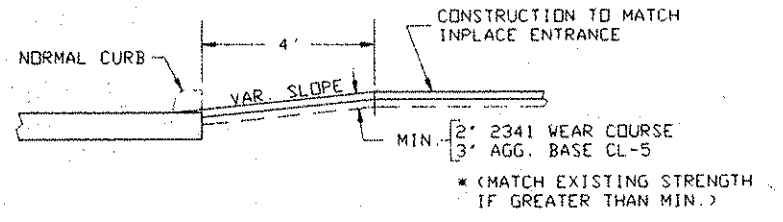

* (MATCH EXISTING STRENGTH IF GREATER THAN MIN.)

GRADING BERM FOR LOCATIONS SEE CHART (P)

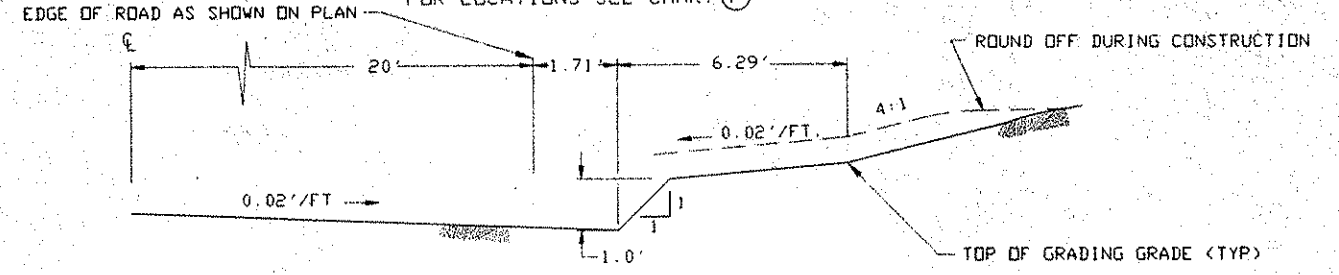

BITUMINOUS CURB DETAIL

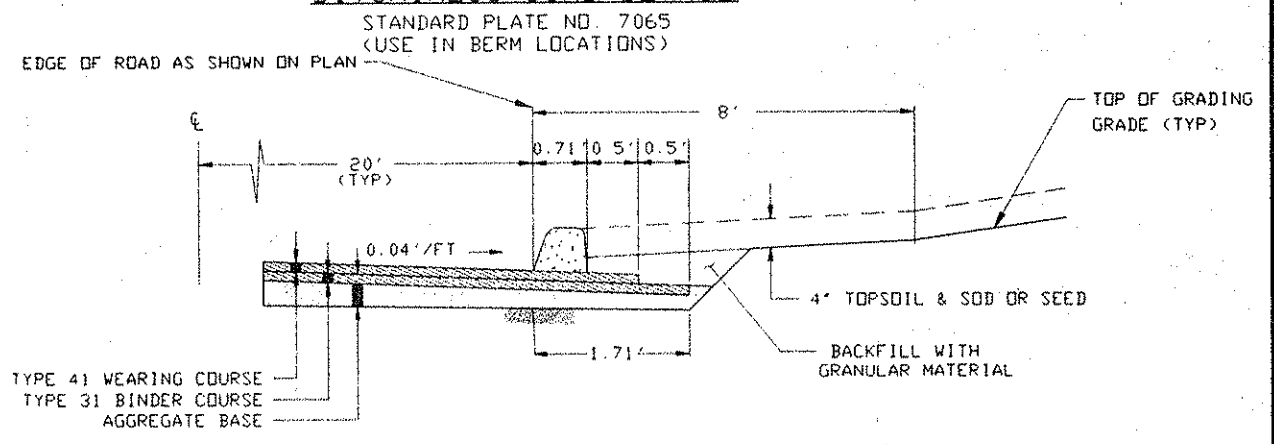

MILLING DETAILS

BUTT JOINTS (PLAN VIEW)

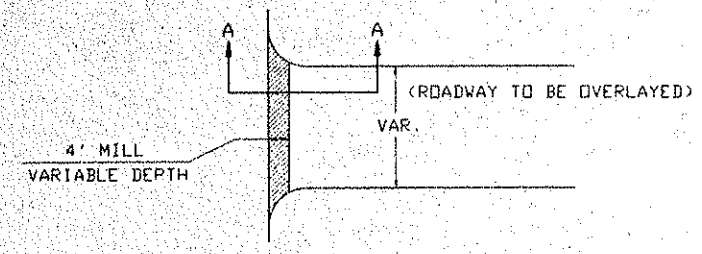

SECTION A-A

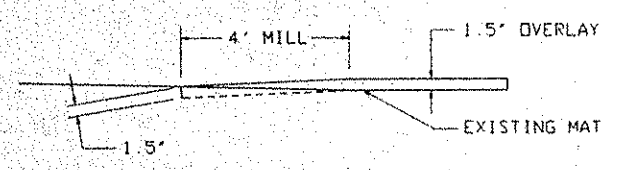

BITUMINOUS SIDE STREETS

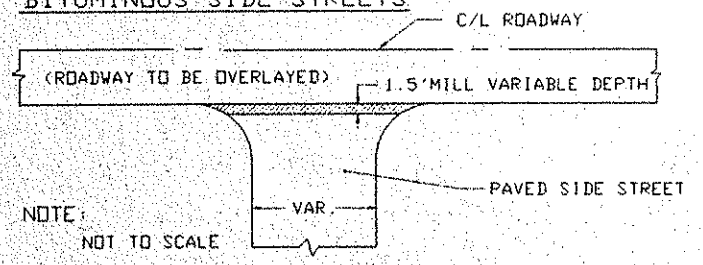

BERM CONSTRUCTION LOCATION (P)

STATION - STATION	LOCATION	LIN. FT.	REMARKS
21+85 - 22+76	20' LT	91	
22+86 - 23+70	20' LT	84	
23+88 - 24+80	20' LT	92	
24+92 - 25+66	20' LT	74	
25+77 - 26+45	20' LT	68	
26+64 - 27+53	20' LT	89	
27+71 - 28+90	20' LT	119	
29+06 - 29+70	20' LT	64	
29+94 - 31+25	20' LT	131	
31+51 - 32+07	20' LT	56	
32+29 - 35+27	20' LT	298	
37+10 - 39+00	20' RT	190	
65+50 - 67+58	20' LT	208	
71+02 - 74+38	20' RT	336	
74+66 - 77+52	20' RT	286	
75+18 - 76+72	20' LT	154	
90+20 - 91+78	24' LT	158	
91+99 - 93+30	20' LT	131	
TOTAL		2629	

REVISIONS	DATE	BY

FILE NAME: P:\3066\TAB-CHDWG.MN.04-30-96

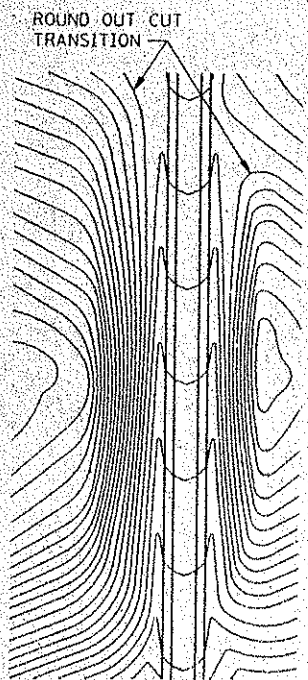

CONTOURING ROAD CUTS

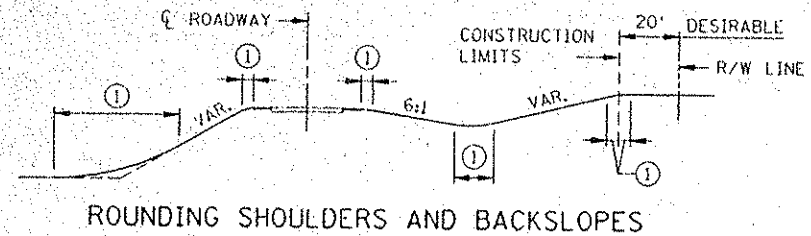

ROUNDING SHOULDERS AND BACKSLOPES

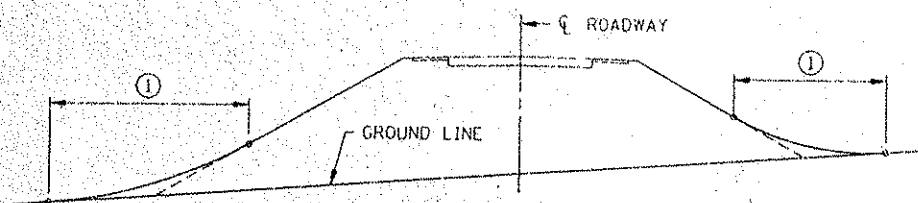

SHAPING FOR DRAINAGE ALONG THE TOE OF FILL SLOPES

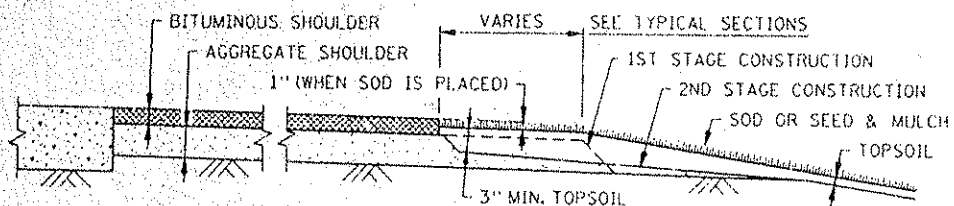

SHAPING AND TOPSOILING INSLOPES

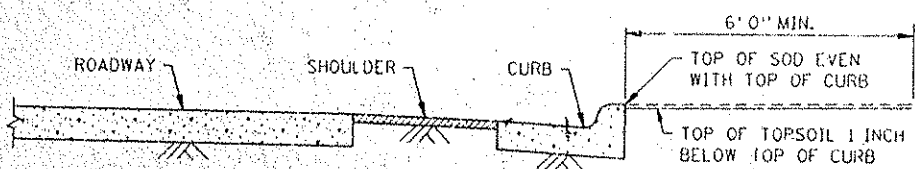

SHAPING ADJACENT TO CURBS WHEN SOD IS PLACED

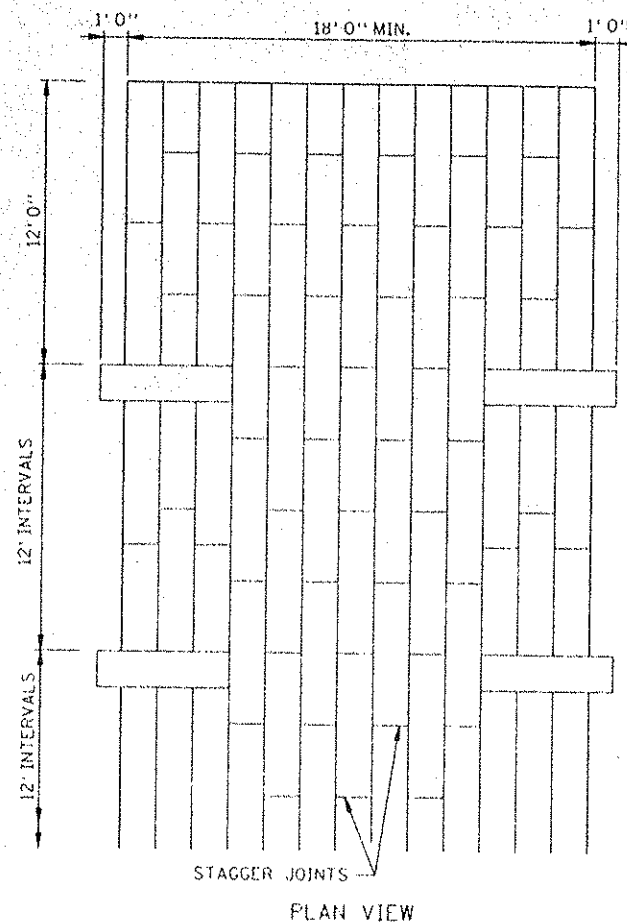

STAGGER JOINTS
PLAN VIEW

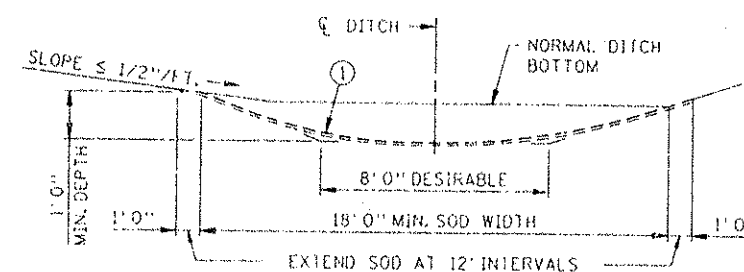

SODDED DITCH CROSS SECTION
WHERE FRONT OR BACK SLOPE IS FLAT (LESS THAN 1/2"/FT.), FIRST NOTCH DITCH AND THEN PROVIDE ROUNDING.

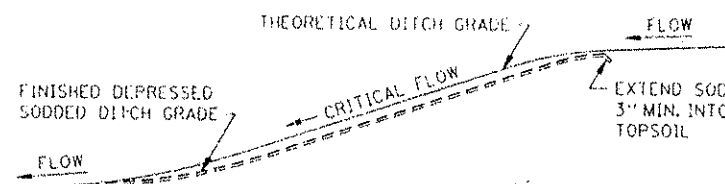

DITCH PROFILE
SODDED DITCH DETAILS

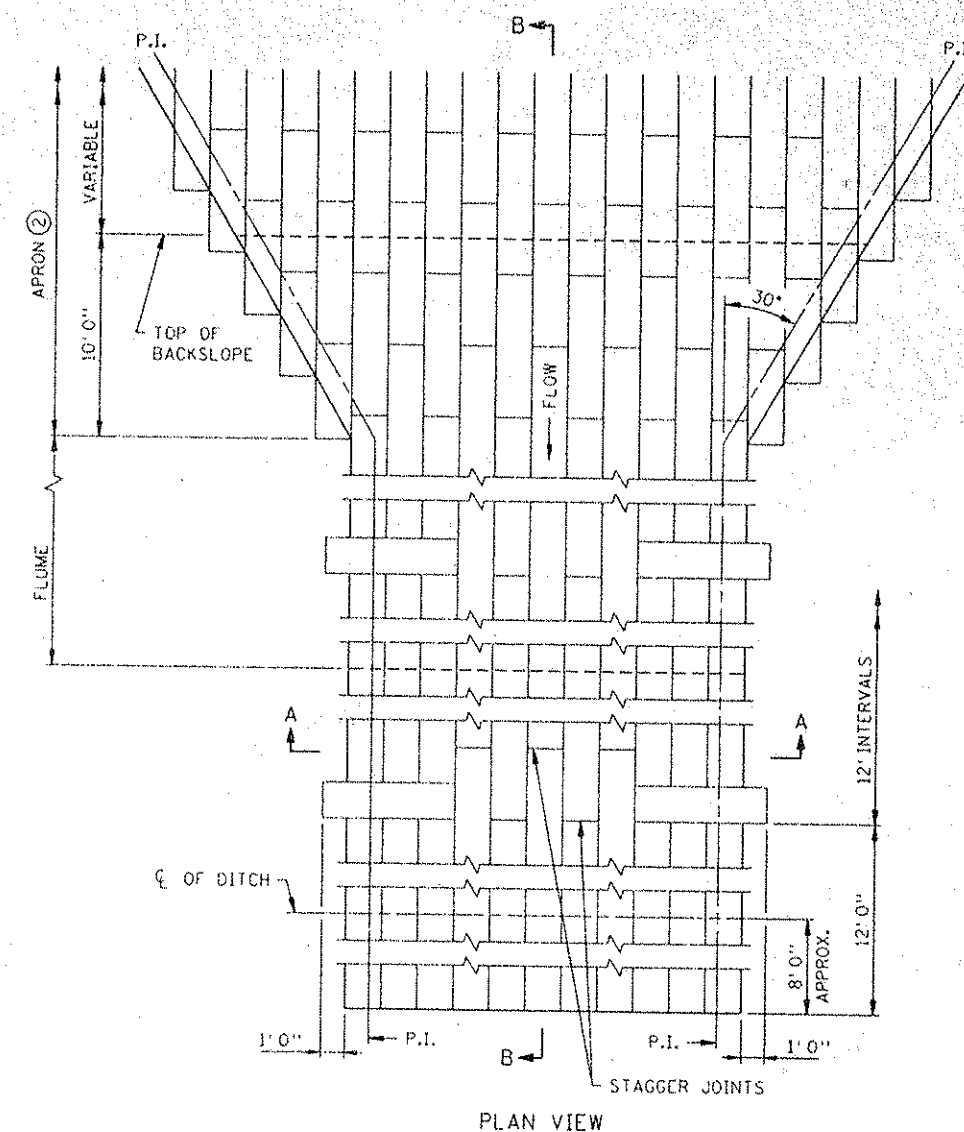

PLAN VIEW

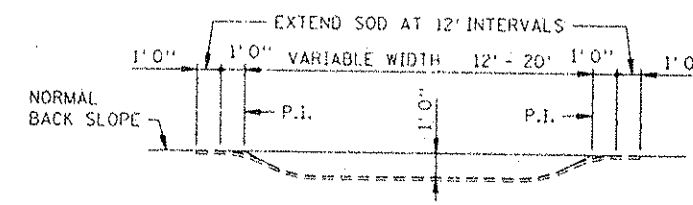

SECTION A-A

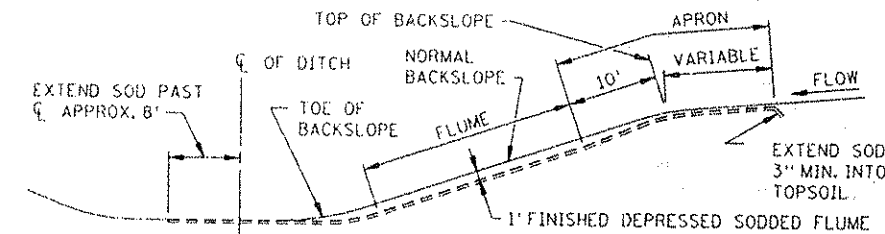

SECTION B-B
SODDED FLUME DETAILS

- NOTES:
 SEE SPEC. 2575.3 FOR ADDITIONAL INFORMATION.
 ① FOR ROUNDING, SEE ROAD DESIGN MANUAL.
 ② CONSTRUCT TAPER AS DIRECTED BY THE ENGINEER.

STANDARD SHEET NO. 5-297.404	TITLE: PERMANENT EROSION CONTROL ALONG ROADWAYS, DITCHES AND FLUMES
STANDARD APPROVED DECEMBER 19, 1990	
STATE PROJ. NO. 93-04-60	SHEET NO. 8 OF 42 SHEETS

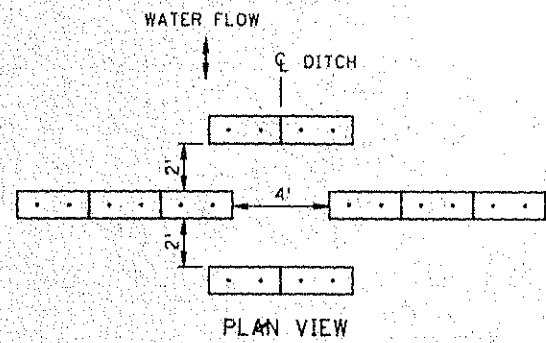

PLAN VIEW

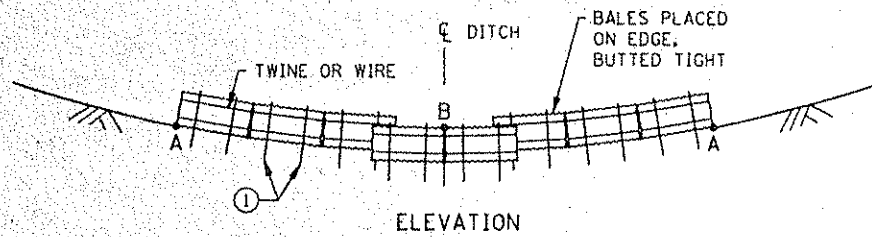

ELEVATION

NOTE:
POINT A MUST BE HIGHER THAN POINT B

BALE DITCH VELOCITY CHECKS
(WILL REQUIRE A MINIMUM OF 10 BALES PER SITE)

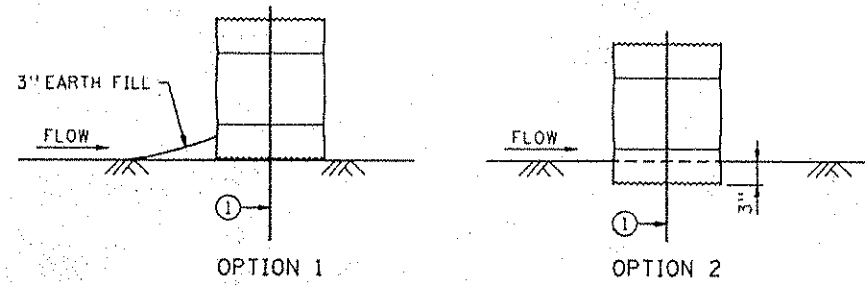

BALE CHECK DETAILS

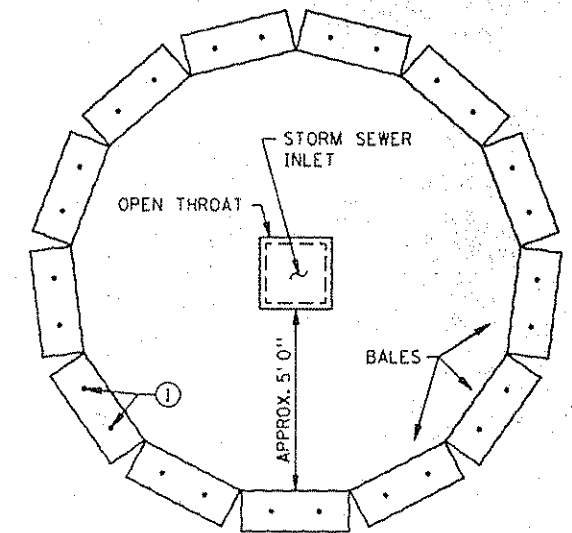

BALE CHECK TO PROTECT STORM SEWER INLETS

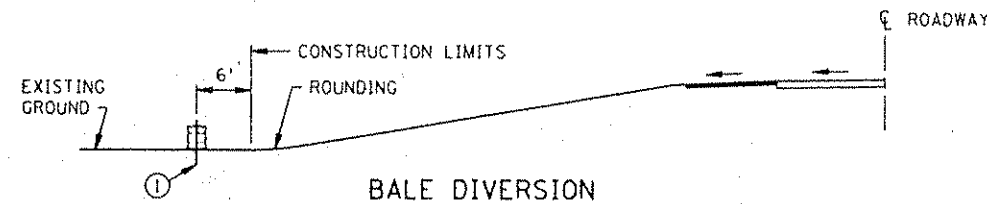

BALE DIVERSION

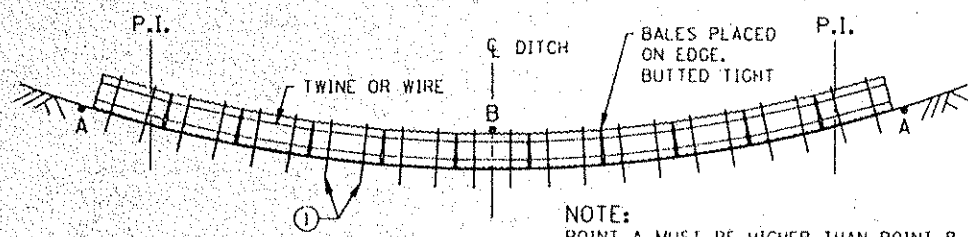

NOTE:
POINT A MUST BE HIGHER THAN POINT B

BALE DITCH SEDIMENT CHECK

RECOMMENDED SPACING BETWEEN BALE DITCH CHECKS	
DITCH GRADE (%)	SPACING (FT.)
2	100
4	75
6	50
8	40
10	25

NOTE:
① TWO 2" X 2" WOOD STAKES OR REINFORCING BARS IN EACH BALE AND EMBEDDED IN THE GROUND 10" MINIMUM.

B.M. #1 ELEV. 913.47
TCP S.W. COR TOP STEP (CHURCH)
STA. 19+00 170' LT

BEG. COUNTY PROJ. 93-04-60 &
BEG. BITUMINOUS OVERLAY
STA. 10+00.00

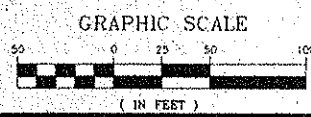
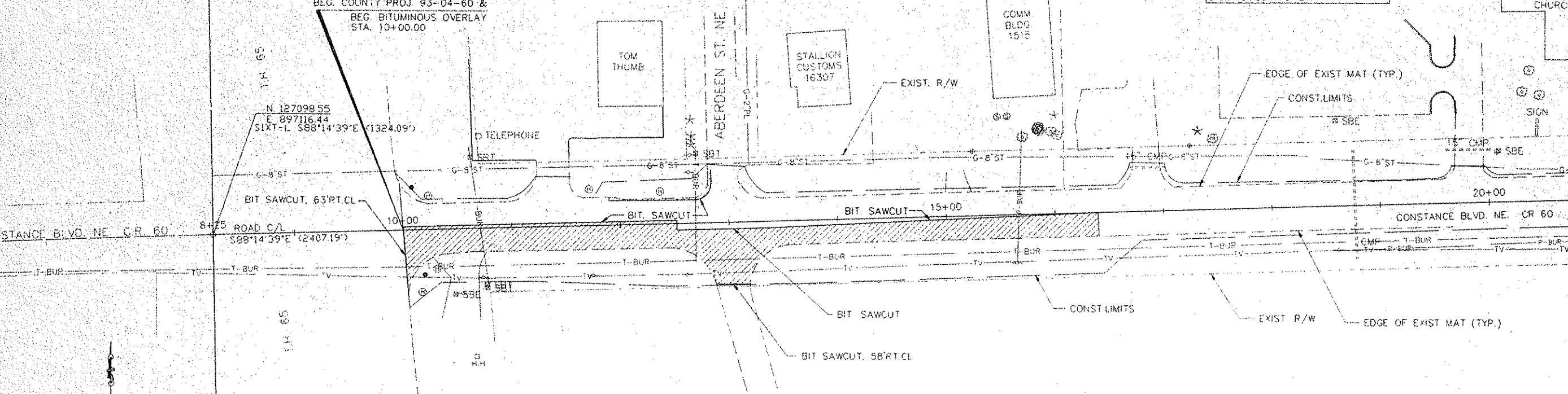

WETLAND
BITUMINOUS REMOVAL

B.M. #2 ELEV. 912.30
TOP S.W. COR TOP STEP
STA. 22+40 LT. #1609
PARCEL 1

NOTE: SEE SHEET 6 AND SPECIAL PROVISIONS
FOR SPECIAL CONDITIONS FOR WORK
PERFORMED ON PARCELS 1, 2, 4, 9, AND 10.

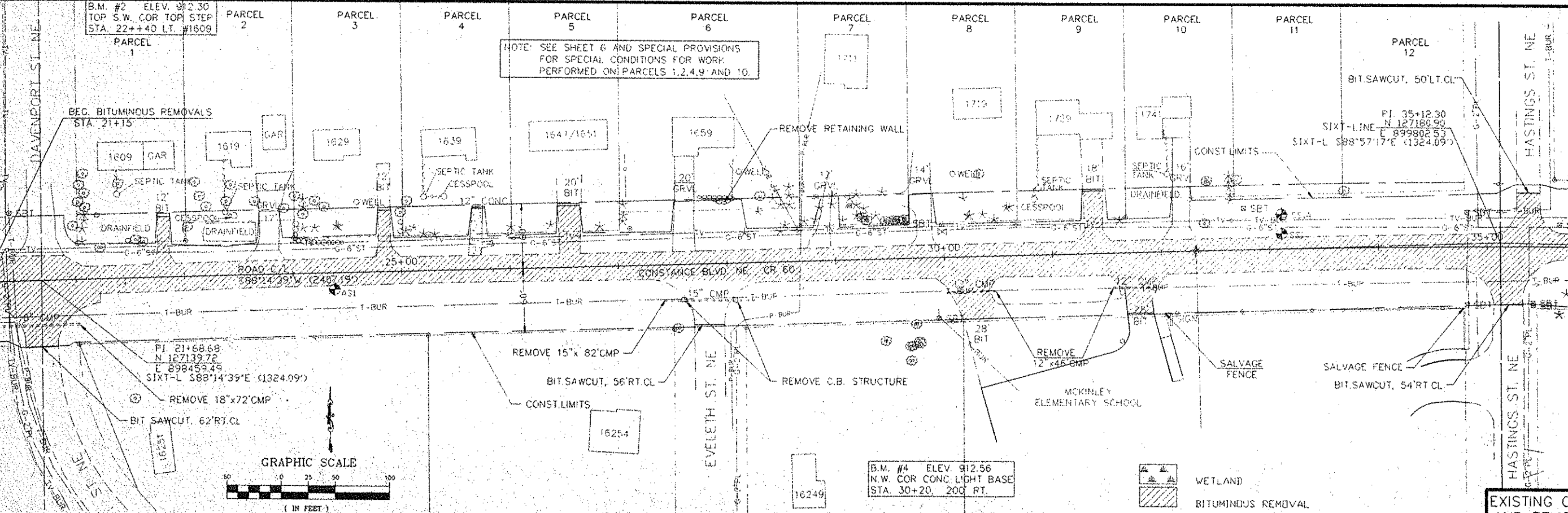

WETLAND
BITUMINOUS REMOVAL

B.M. #4 ELEV. 912.56
N.W. COR CONC. LIGHT BASE
STA. 30+20, 200' RT.

EXISTING CONDITIONS
AND REMOVAL PLAN
STA. 10+00 TO 36+00

REV.	DATE	BY

B.M. #5 ELEV. 914.99
DBL SPIKE IN P.P.
STA. 274+65.33' LT.

B.M. #6 ELEV. 912.90
DBL SPIKE IN P.P.
STA. 43.70, 33' LT.

B.M. #7 ELEV. 913.49
DBL SPIKE IN P.P. MANKATO
STA. 49+85, 100' LT.

PARCEL
13
2045

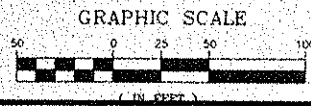
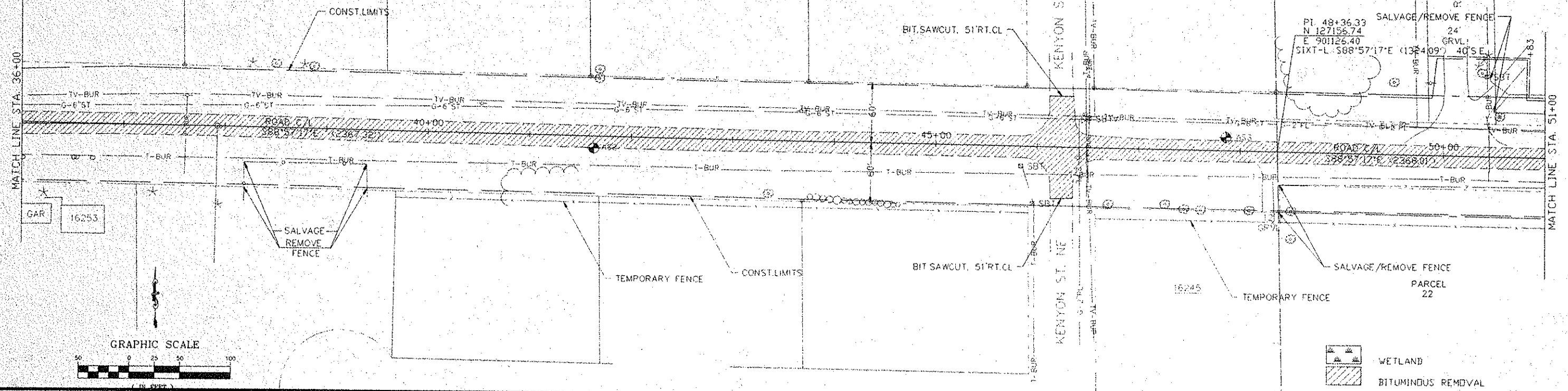

WETLAND
BITUMINDUS REMOVAL

PARCEL 13

B.M. #8 ELEV. 914.08
DBL SPIKE IN P.P.
STA. 55+75.33' LT.

PARCEL 14

B.M. #9 ELEV. 914.08
DBL SPIKE IN P.P. QUAMBA
STA. 64.40, 100' LT.

PARCEL 14

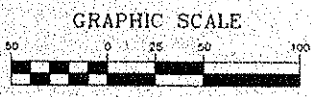
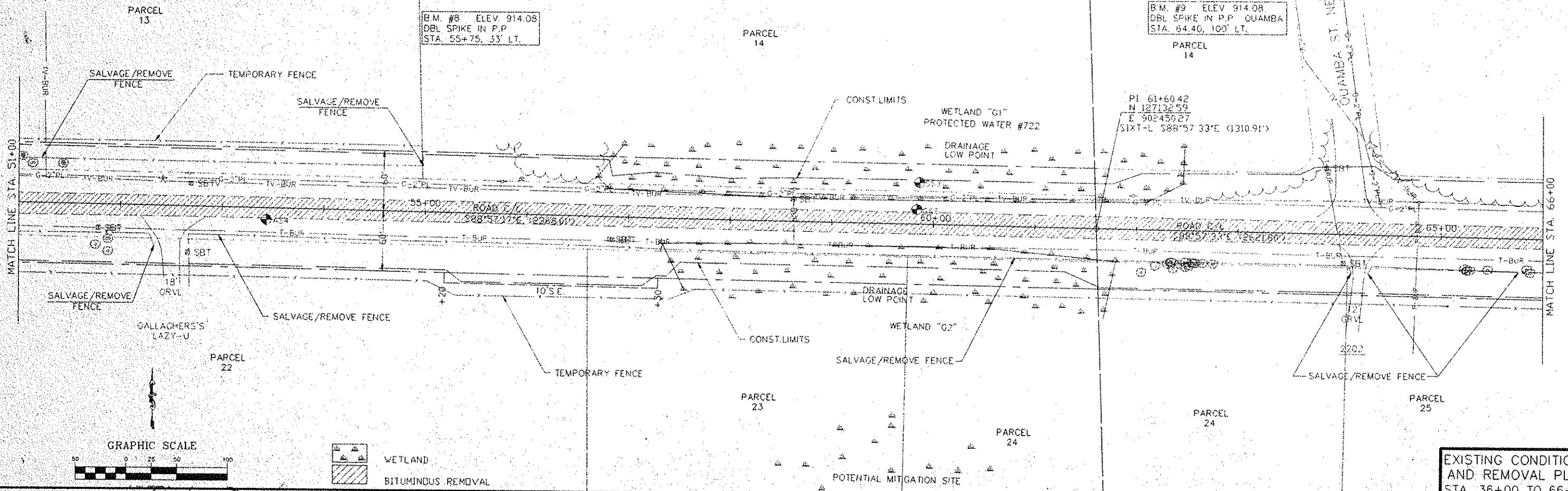

WETLAND
BITUMINDUS REMOVAL

EXISTING CONDITIONS
AND REMOVAL PLAN
STA. 36+00 TO 66+00

REVISIONS	DATE	BY

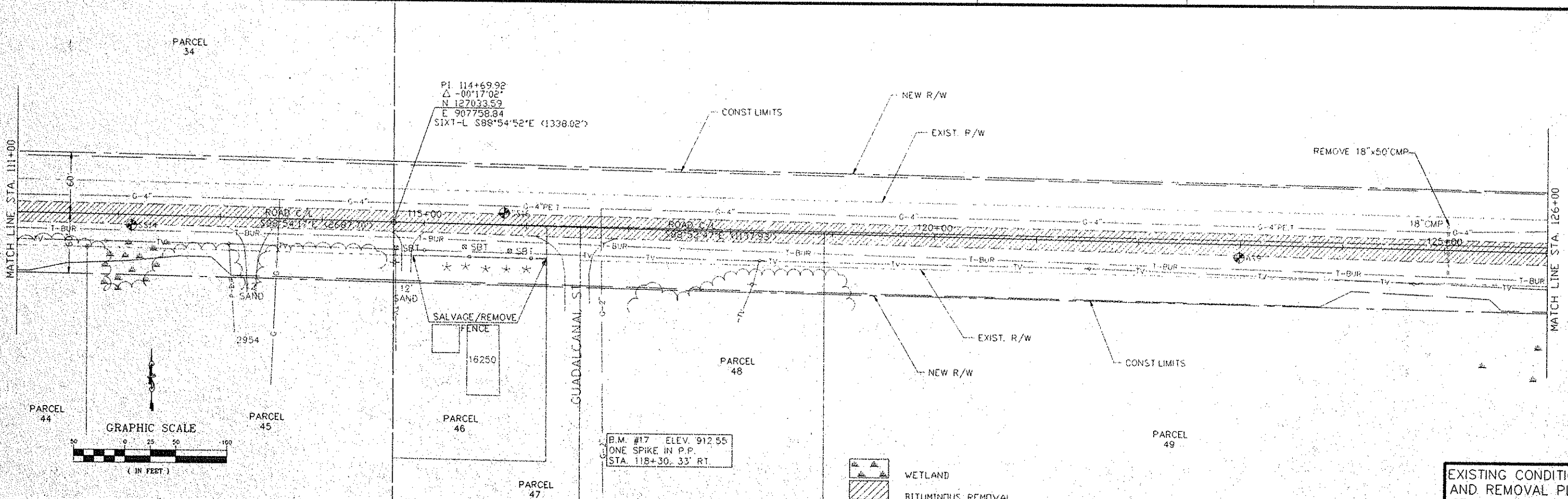
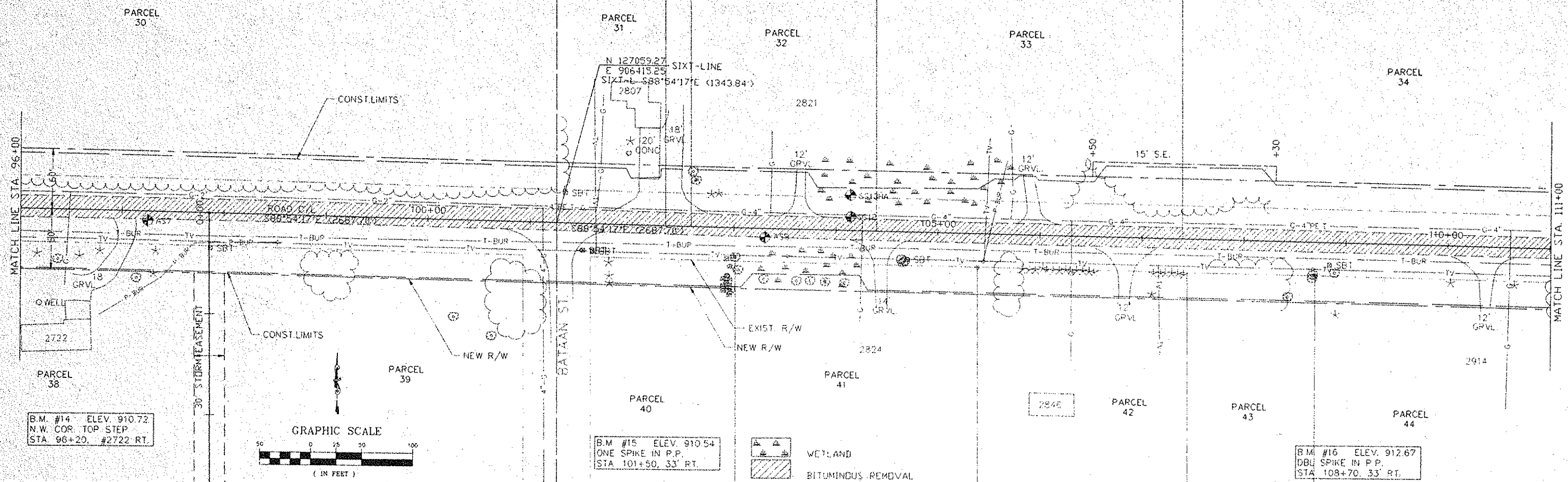

REVISIONS	DATE	BY

CERTIFIED BY [Signature] P.E. REG. NO. 20235 April 30, 1996

S.P. _____ S.A.P. _____ C.P. 93-04-60 Sheet No. 15 of 42 Sheets

EXISTING CONDITIONS AND REMOVAL PLAN STA. 96+00 TO 126+00

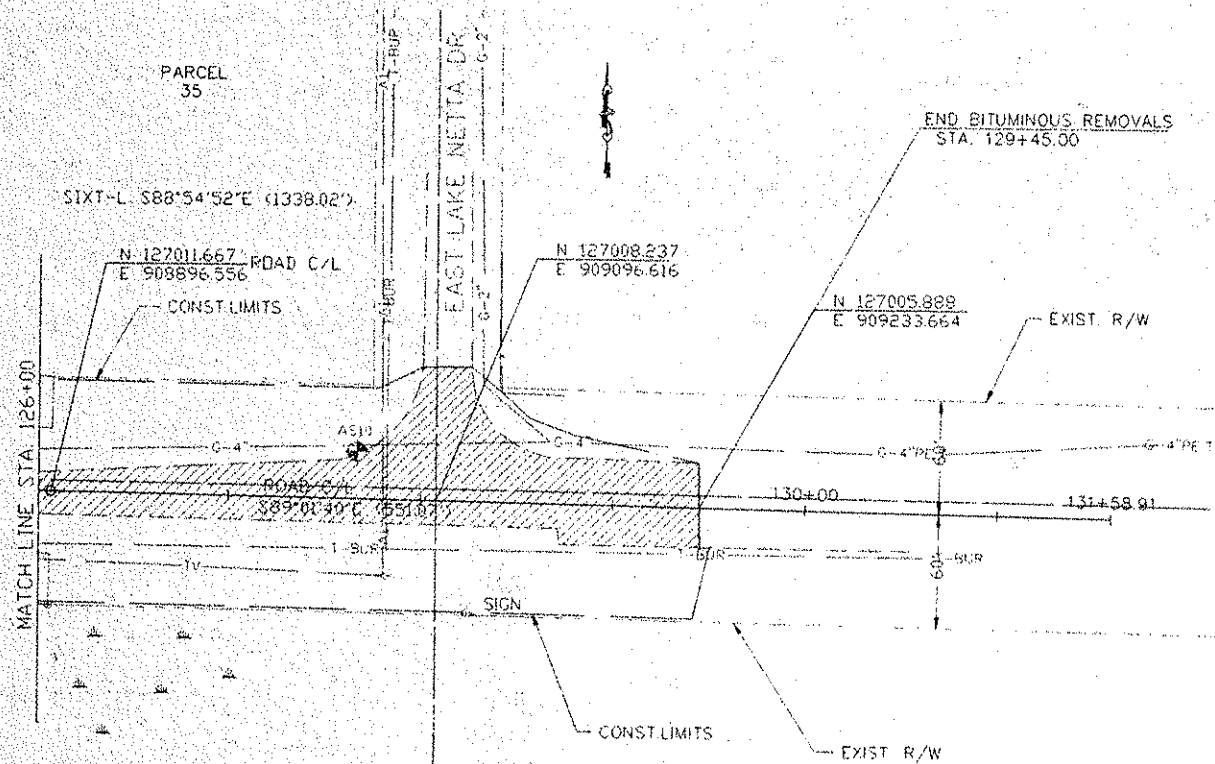

B.M. #18 ELEV. 903.48
RR SPIKE IN 24" OAK
STA. 129+50.60' RT.

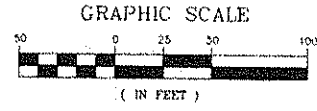

WETLAND
 BITUMINOUS REMOVAL

REVISIONS	DATE	BY

FILE NAME: P:\030460\EXIST-2.DWG 11/11/04 10:30:56

CERTIFIED BY *[Signature]* P.E. REG NO. 20235 April 30 19 96

S.P. _____ S.A.P. _____ C.P. 93-04-60

Sheet No. 16 of 42 Sheets

EXISTING CONDITIONS AND REMOVAL PLAN
STA. 126+00 TO 131+00

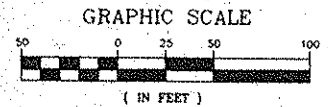
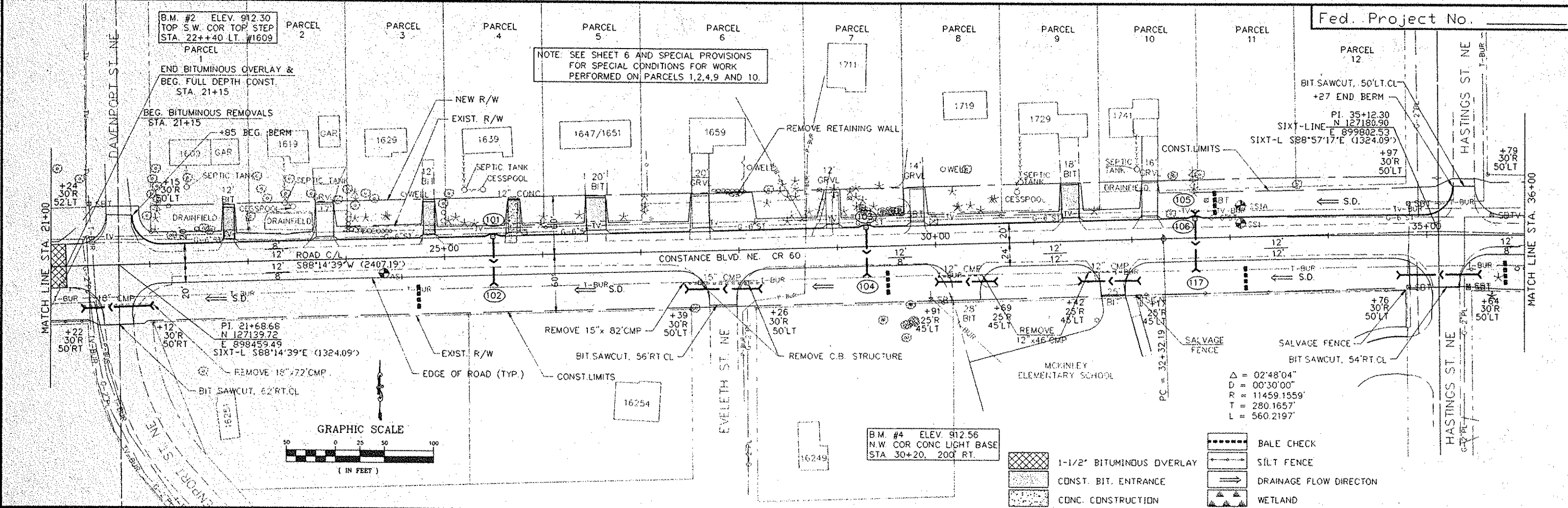

NOTE:
ALL PROFILE INFO. BASED ON GRADING GRADE

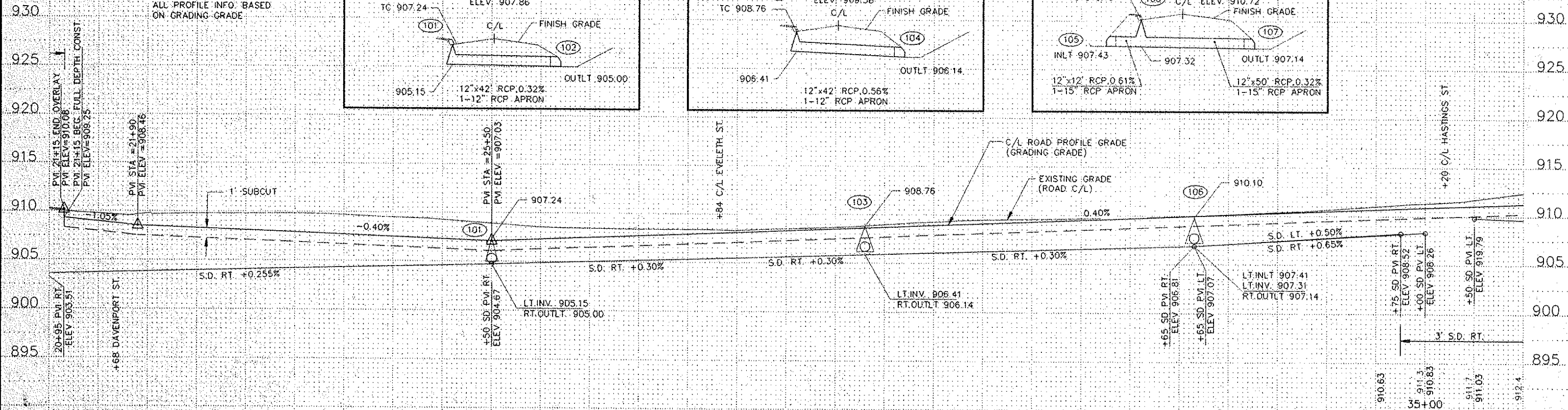
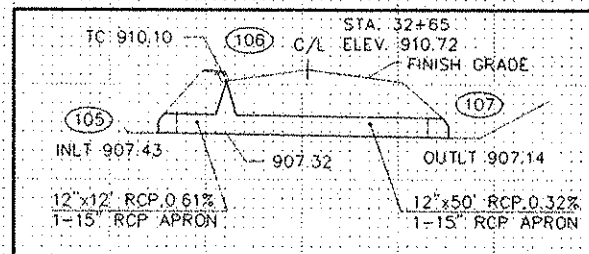
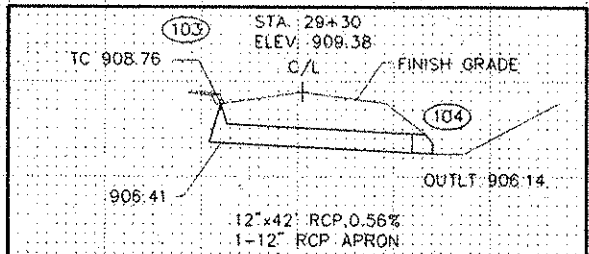
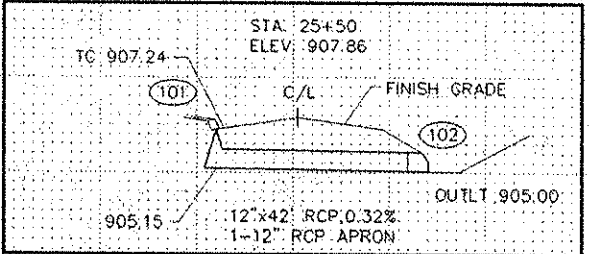

REVISIONS	DATE	BY

B.M. #5 ELEV. 914.99
DBL SPIKE IN P.P.
STA. 27+65, 33' LT.

B.M. #6 ELEV. 912.90
DBL SPIKE IN P.P.
STA. 43.70, 33' LT.

Fed. Project No. _____

B.M. #7 ELEV. 913.49
DBL SPIKE IN P.P. MANKATO
STA. 49+85, 100' LT.

PARCEL 13
2045

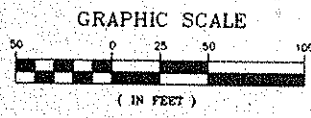
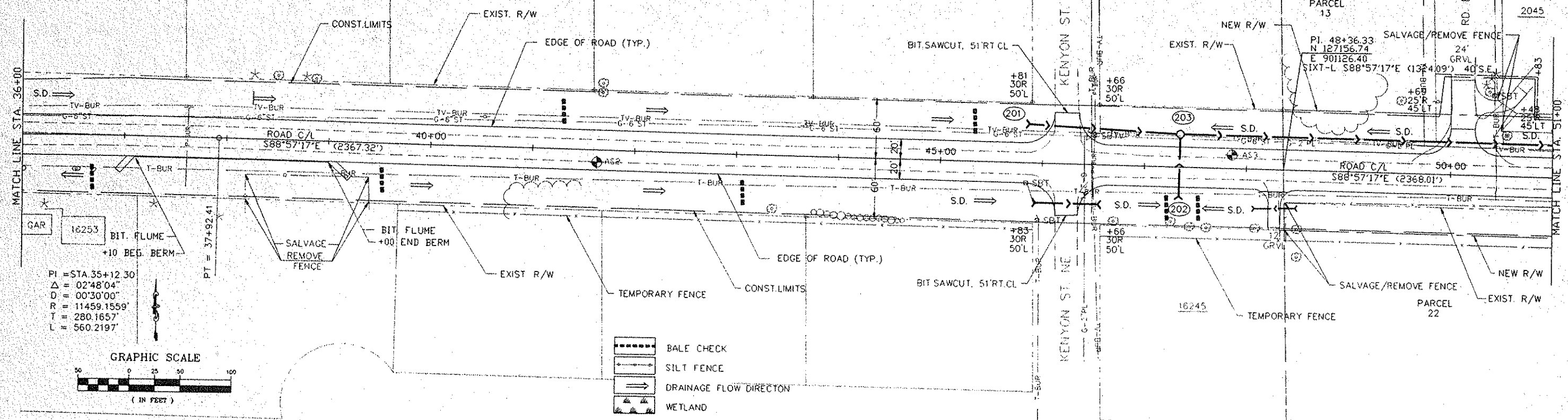

- BALE CHECK
- SILT FENCE
- DRAINAGE FLOW DIRECTION
- WETLAND

NOTE:
ALL PROFILE INFO. BASED
ON GRADING GRADE

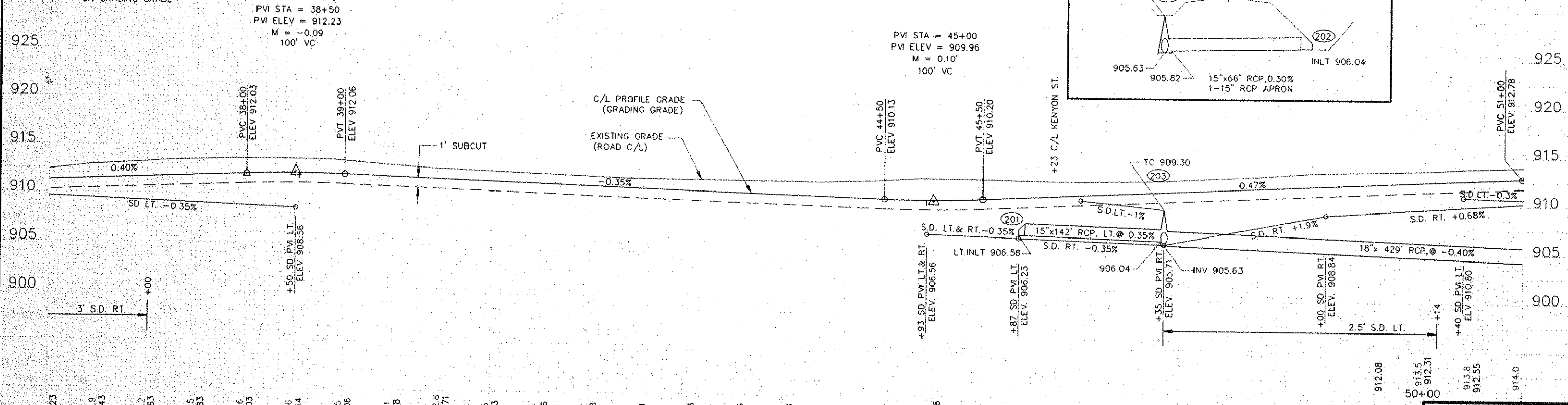

REVISIONS	DATE	BY

CERTIFIED BY *[Signature]*

P.E. REG NO. 20235 April 30 19 96

S.P. _____ S.A.P. _____ C.P. 93-04-60 Sheet No. 19 of 42 Sheets

PLAN & PROFILE
STA. 36+00 TO 51+00

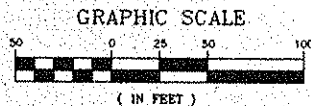
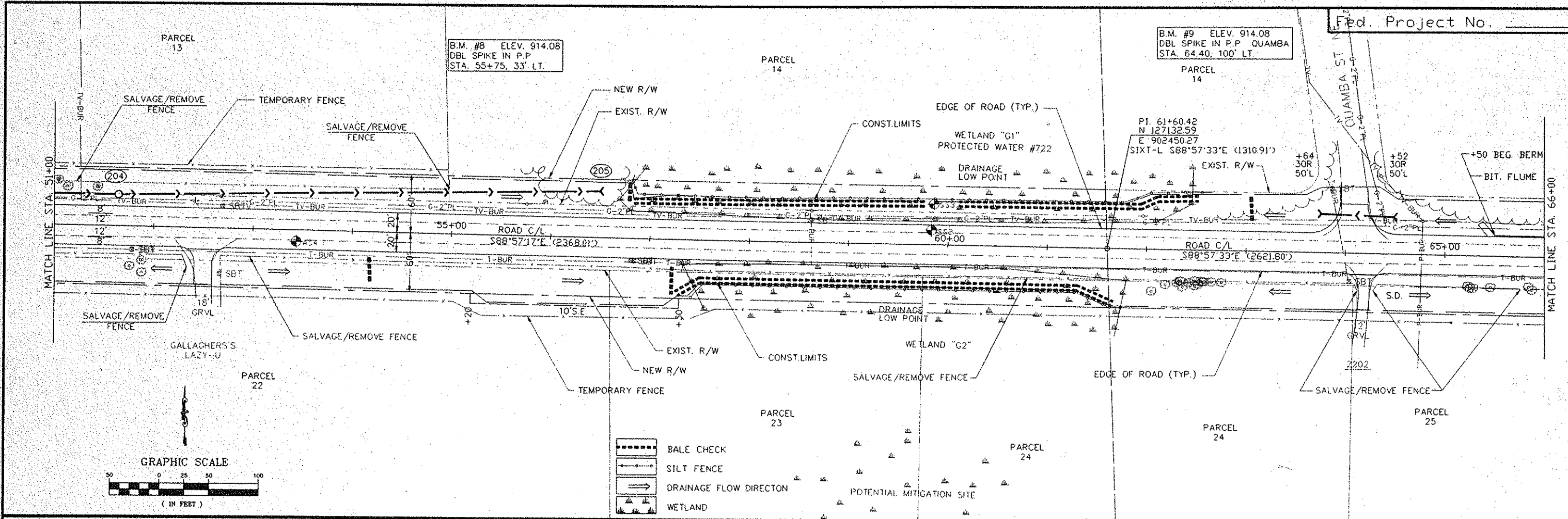

- BALE CHECK
- SILT FENCE
- DRAINAGE FLOW DIRECTION
- WETLAND

NOTE:
ALL PROFILE INFO. BASED
ON GRADING GRADE

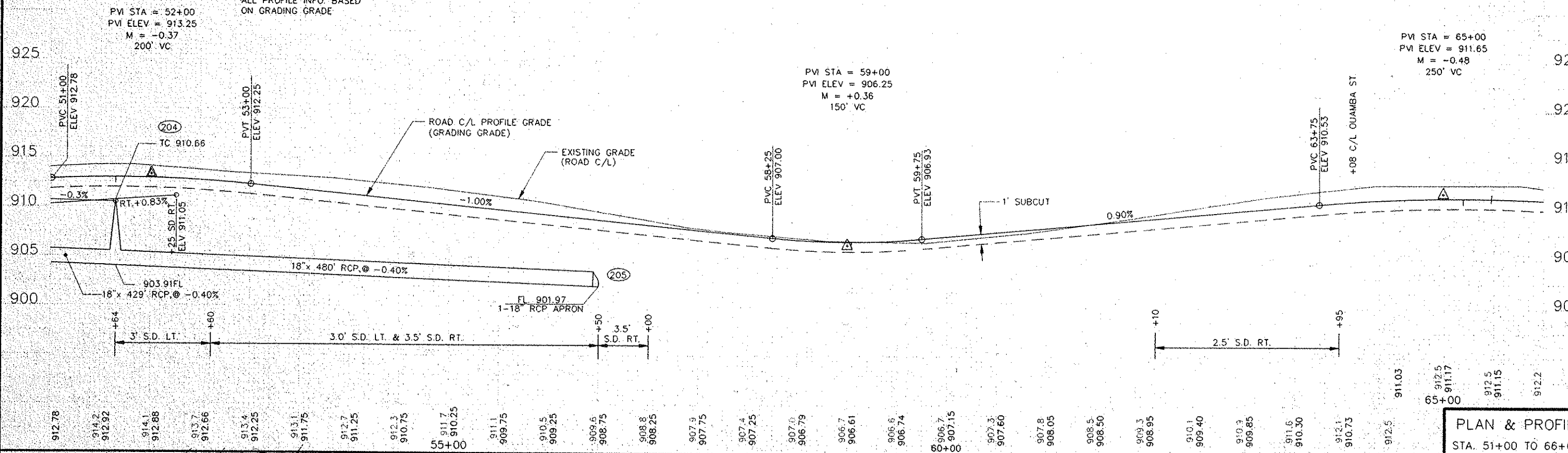

REVISIONS	DATE	BY

B.M. #10 ELEV. 909.37
DBL SPIKE 10" OAK
STA. 73+55.60' LT.

B.M. #11 ELEV. 911.32
TOP S.E. COR. STEP
STA. 79+25. #2427 LT.

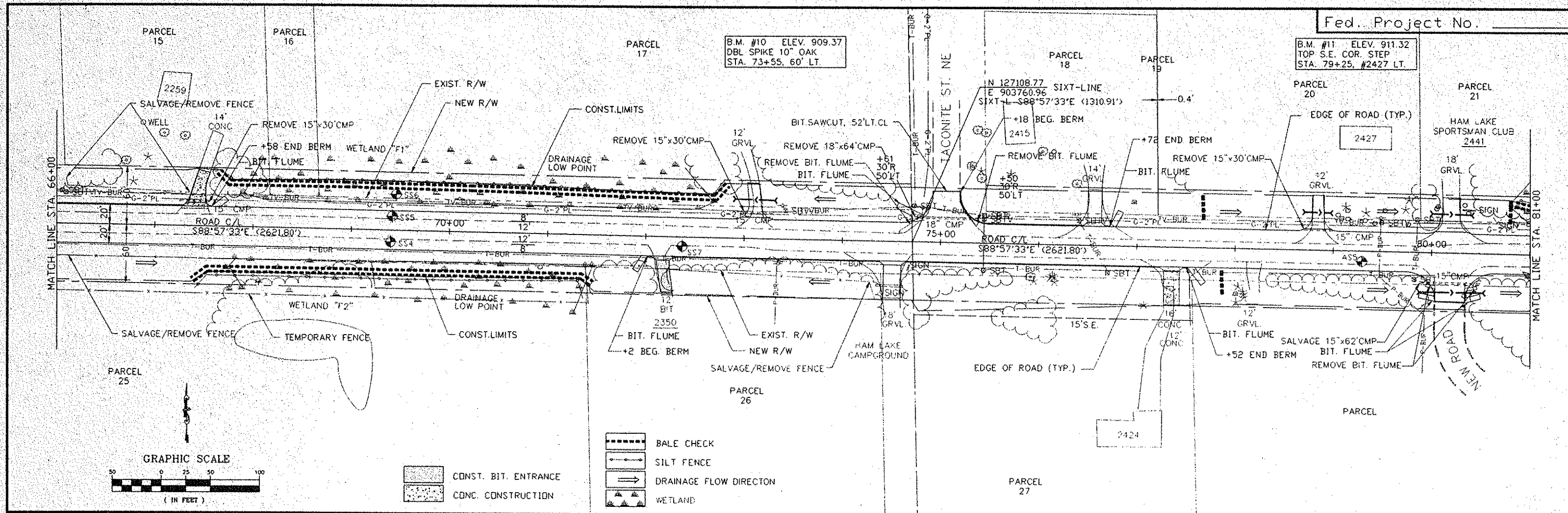

NOTE:
ALL PROFILE INFO. BASED
ON GRADING GRADE.

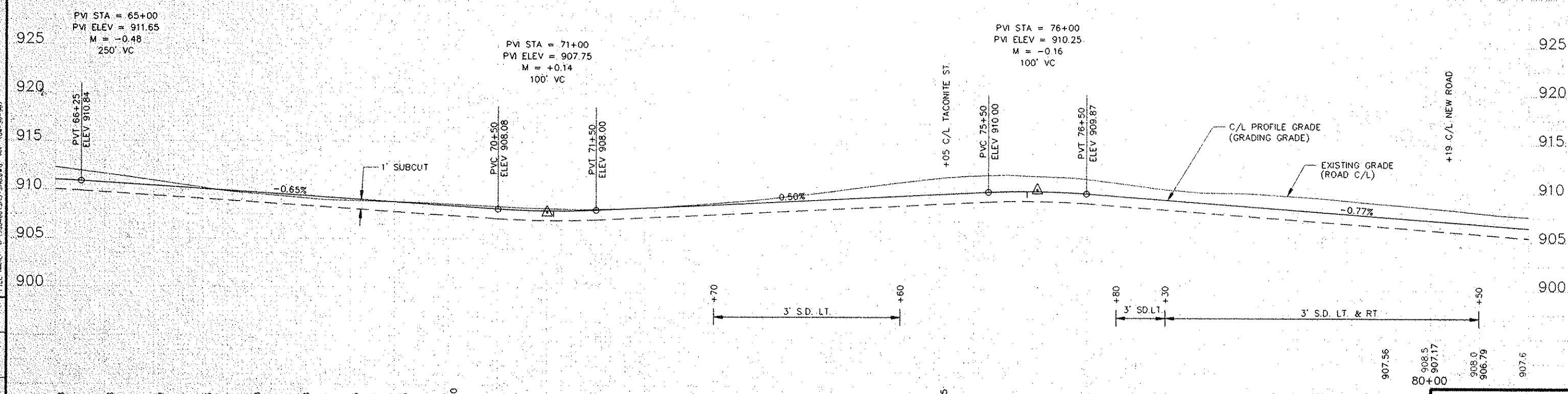

REVISIONS	DATE	BY

CERTIFIED BY *[Signature]* P.E. REG NO. 20235 April 30, 19 96 S.P. _____ S.A.P. _____ C.P. 93-04-60 Sheet No. 21 of 42 Sheets

PLAN & PROFILE
STA. 66+00 TO 81+00

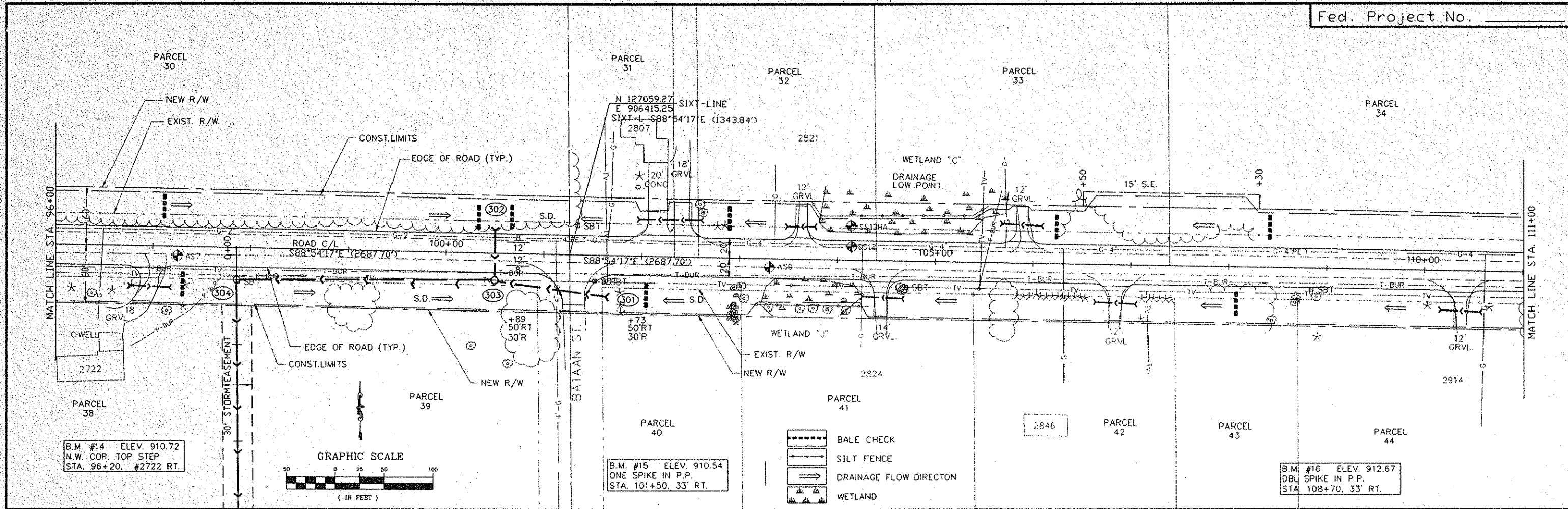

NOTE:
ALL PROFILE INFO. BASED ON GRADING GRADE

PVI STA = 101+50
 PVI ELEV = 908.00
 M = +0.79
 100' VC

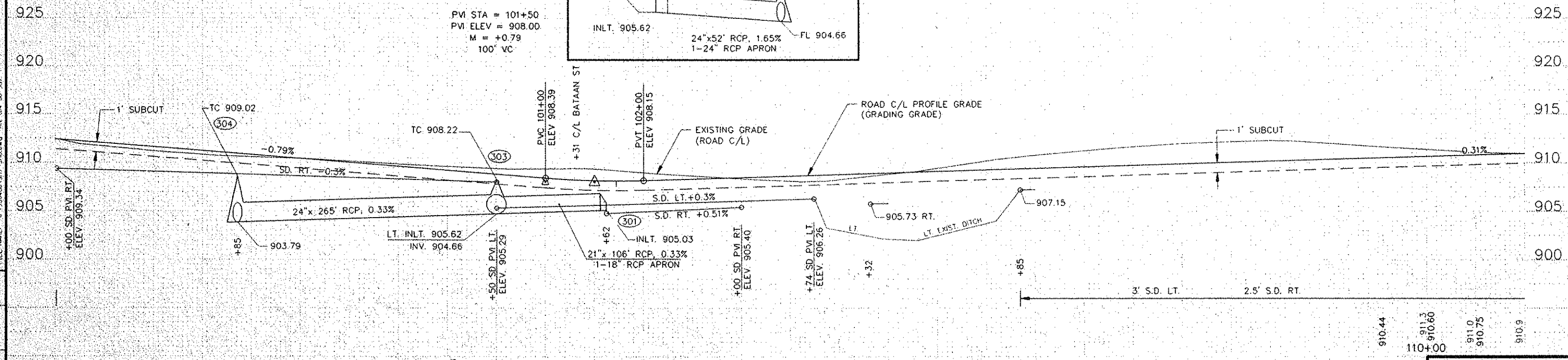
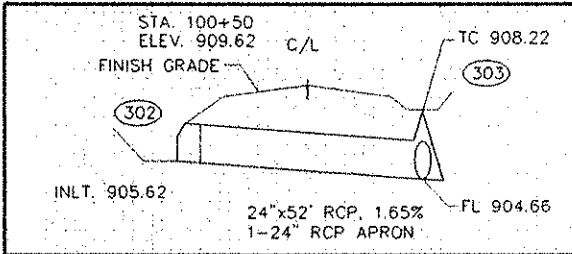

PLAN & PROFILE
 STA. 96+00 TO 111+00

REVISIONS	DATE	BY

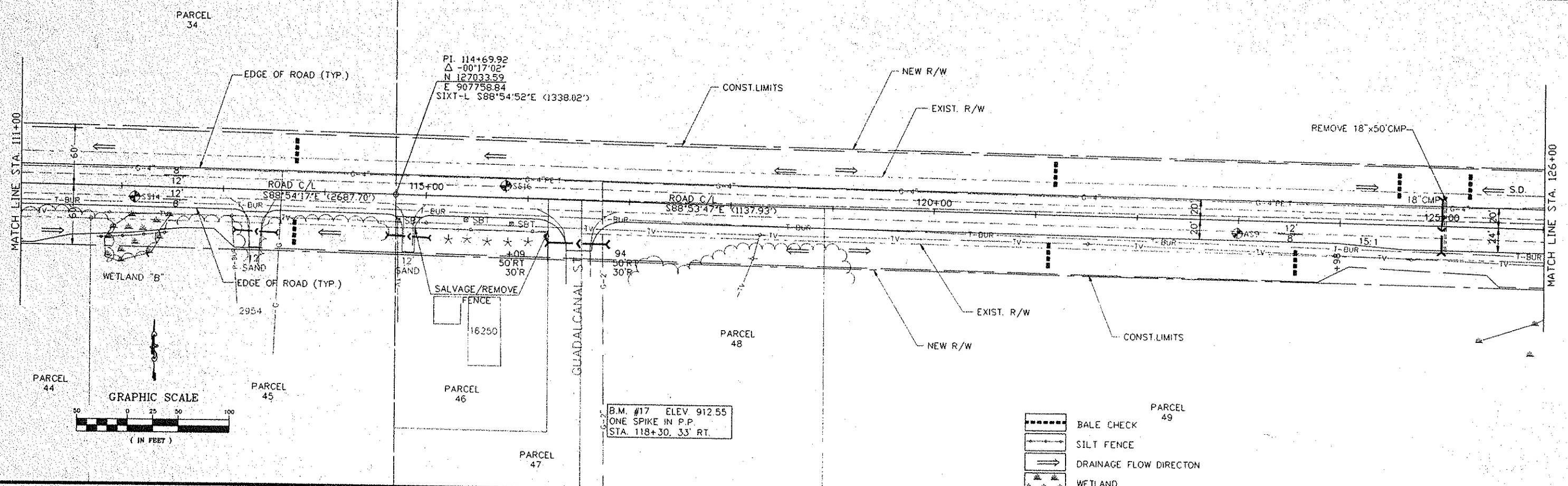

NOTE:
ALL PROFILE INFO. BASED
ON GRADING GRADE

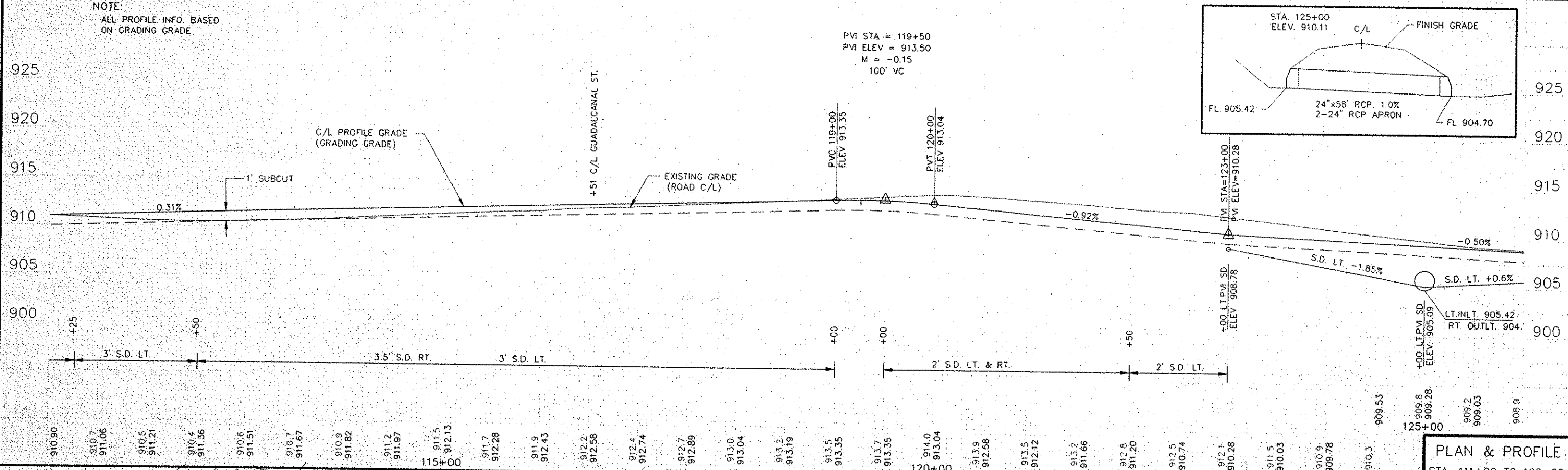

REVISIONS	DATE	BY

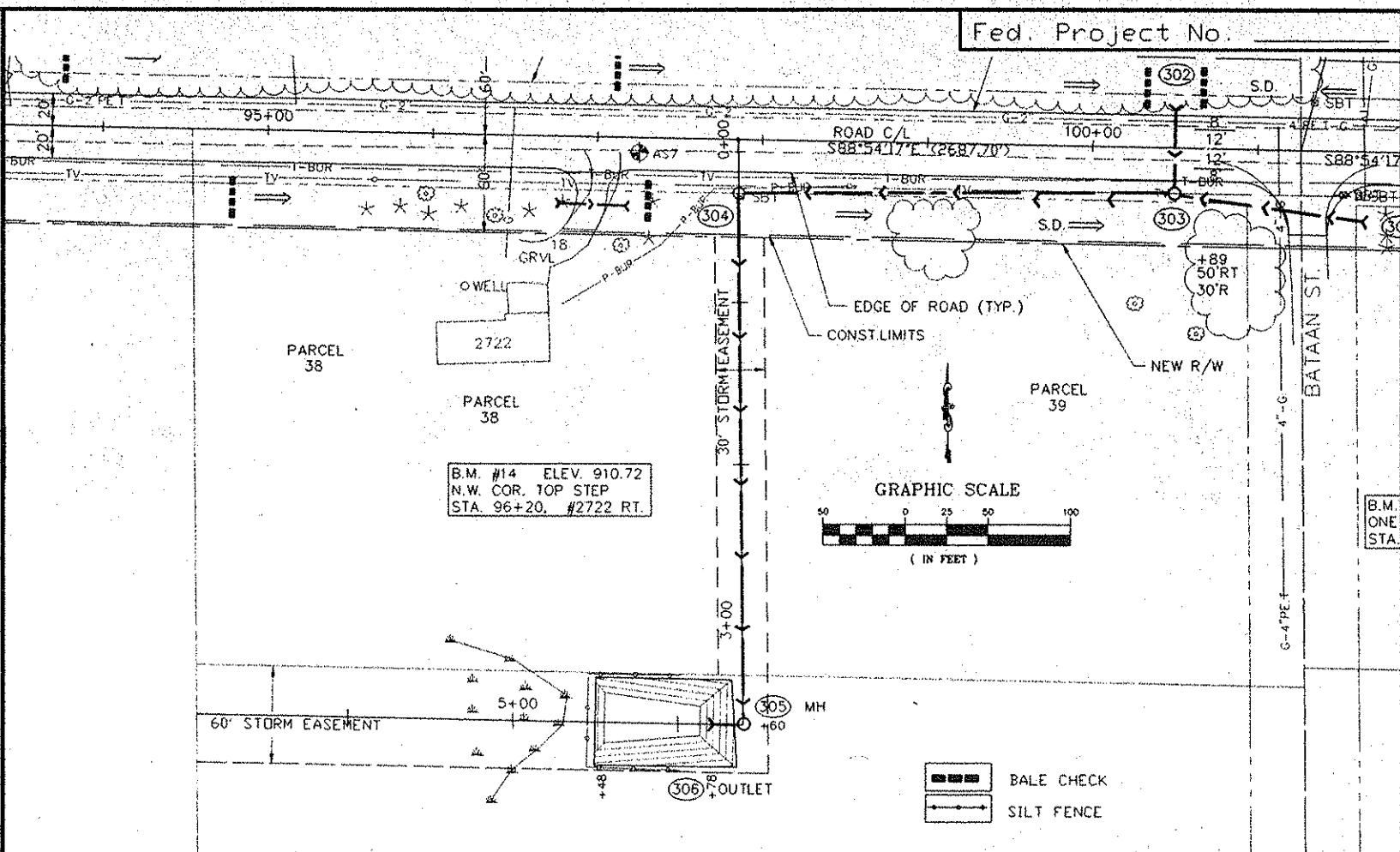
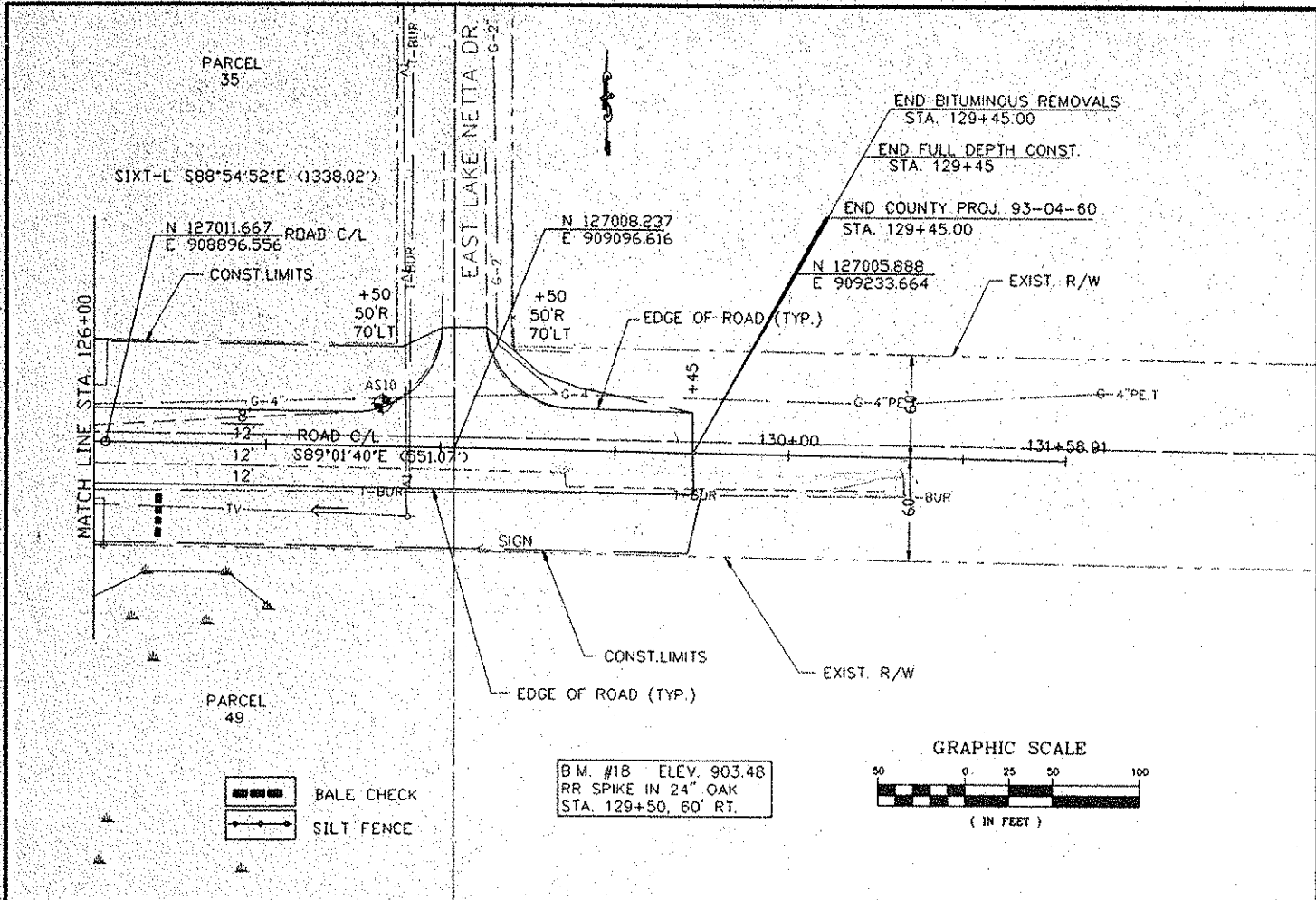

NOTE:
ALL PROFILE INFO. BASED
ON GRADING GRADE

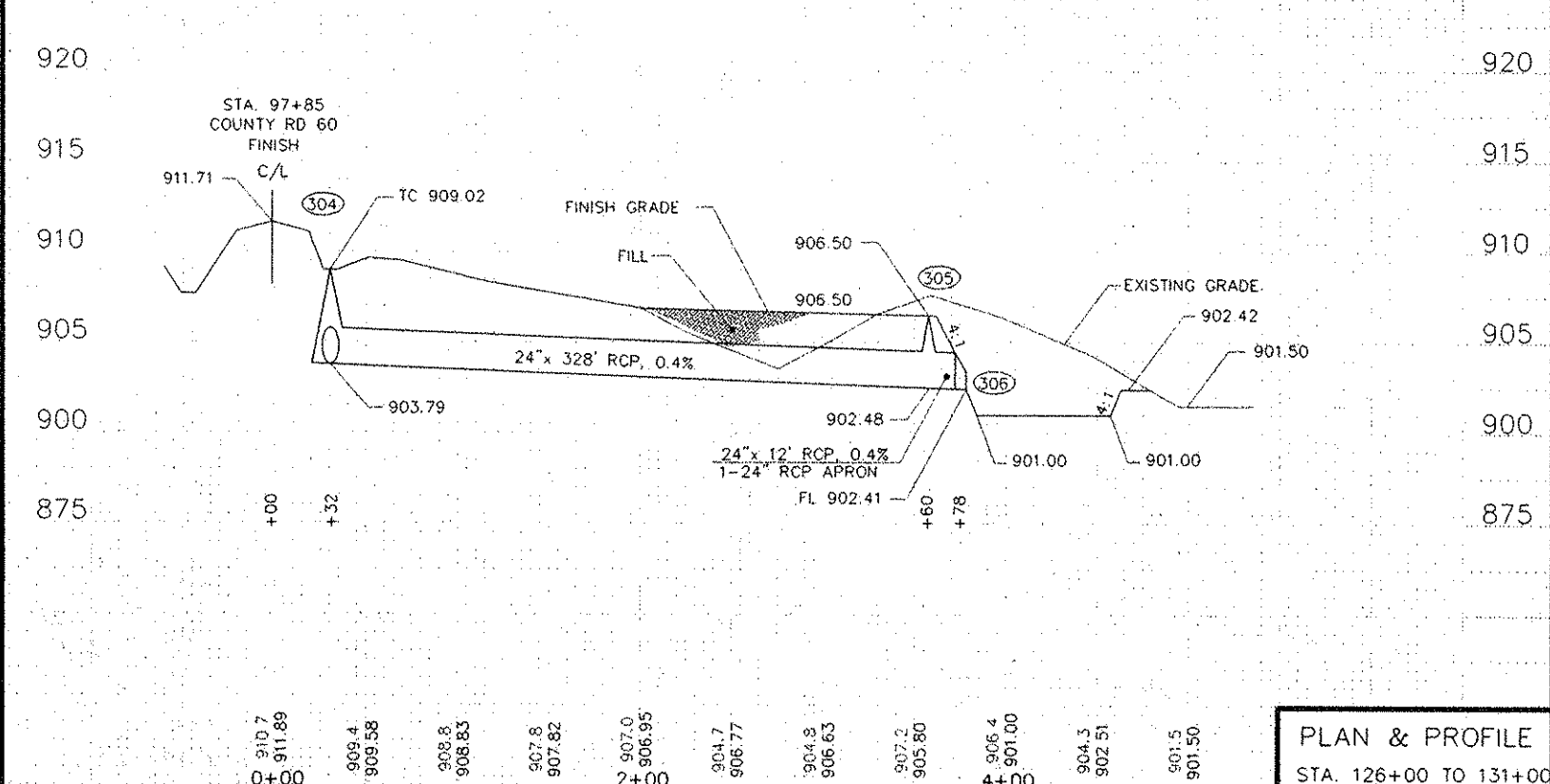
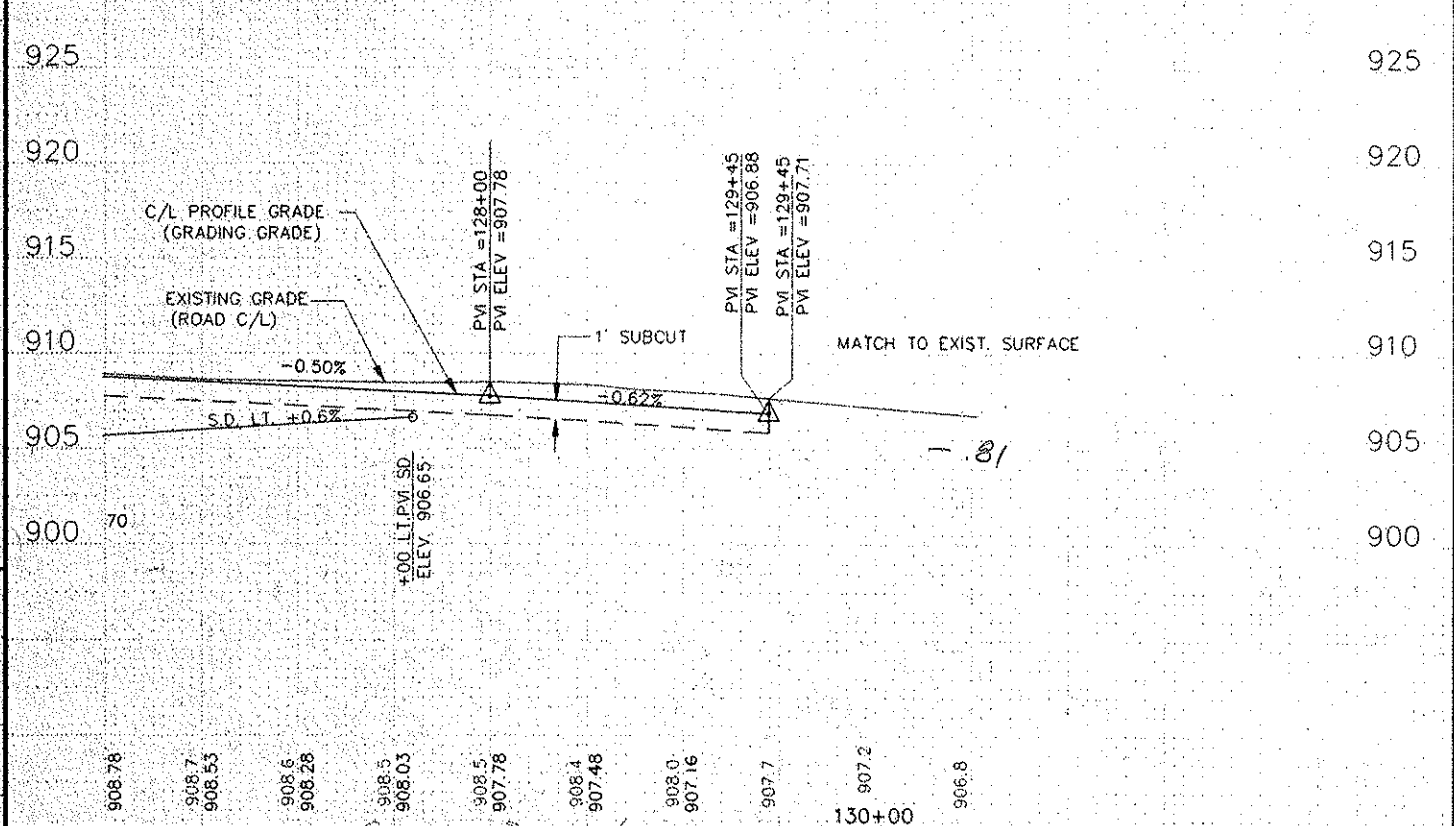

REVISIONS	DATE	BY

EXCAVATION EMBANKMENT
 SUB-TOTALS CU.YDS. SUB-TOTALS CU.YDS.

Proj. No. **EXCAVATION EMBANKMENT**
 SUB-TOTALS CU.YDS. SUB-TOTALS CU.YDS.

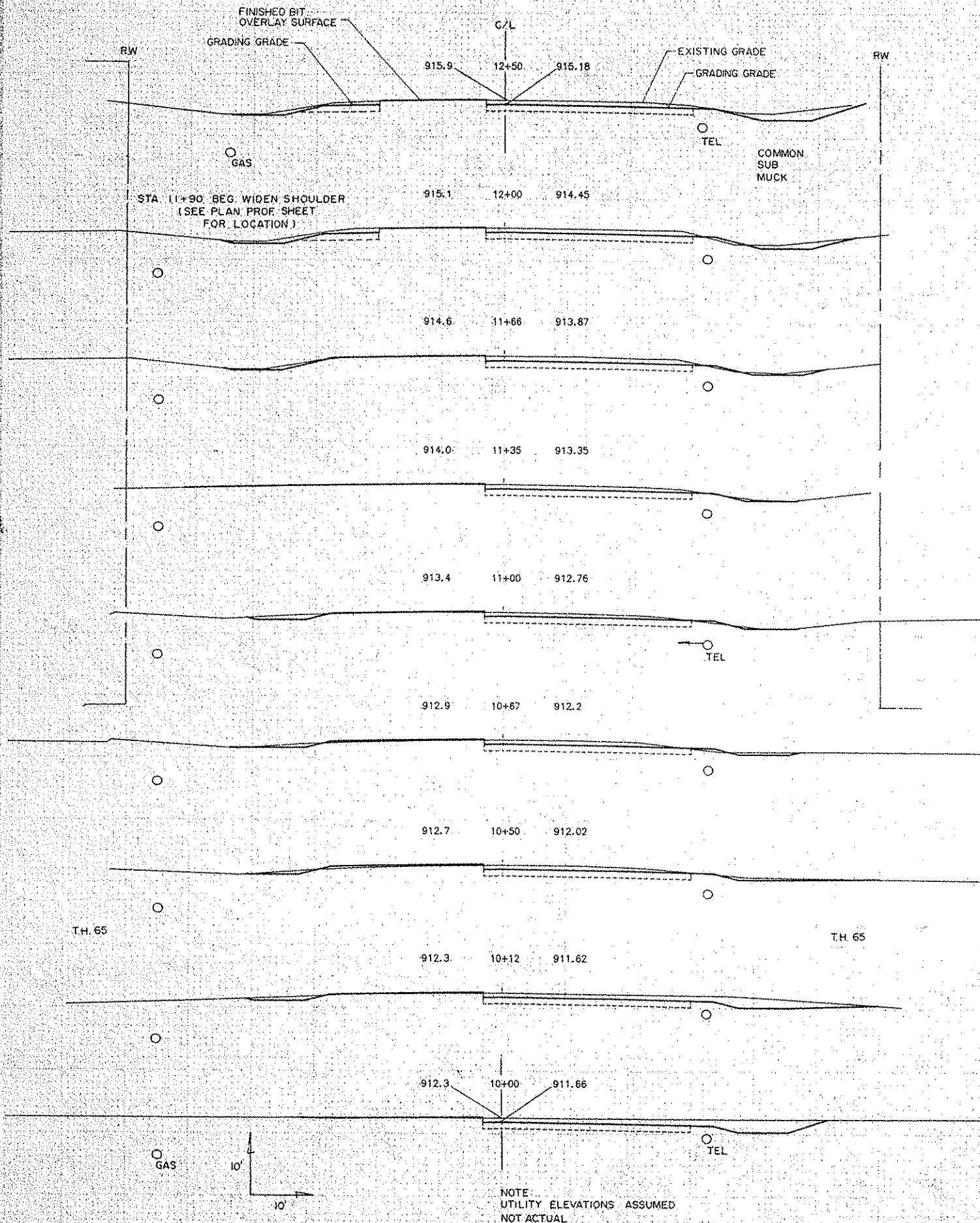

NOTE:
 UTILITY ELEVATIONS ASSUMED
 NOT ACTUAL

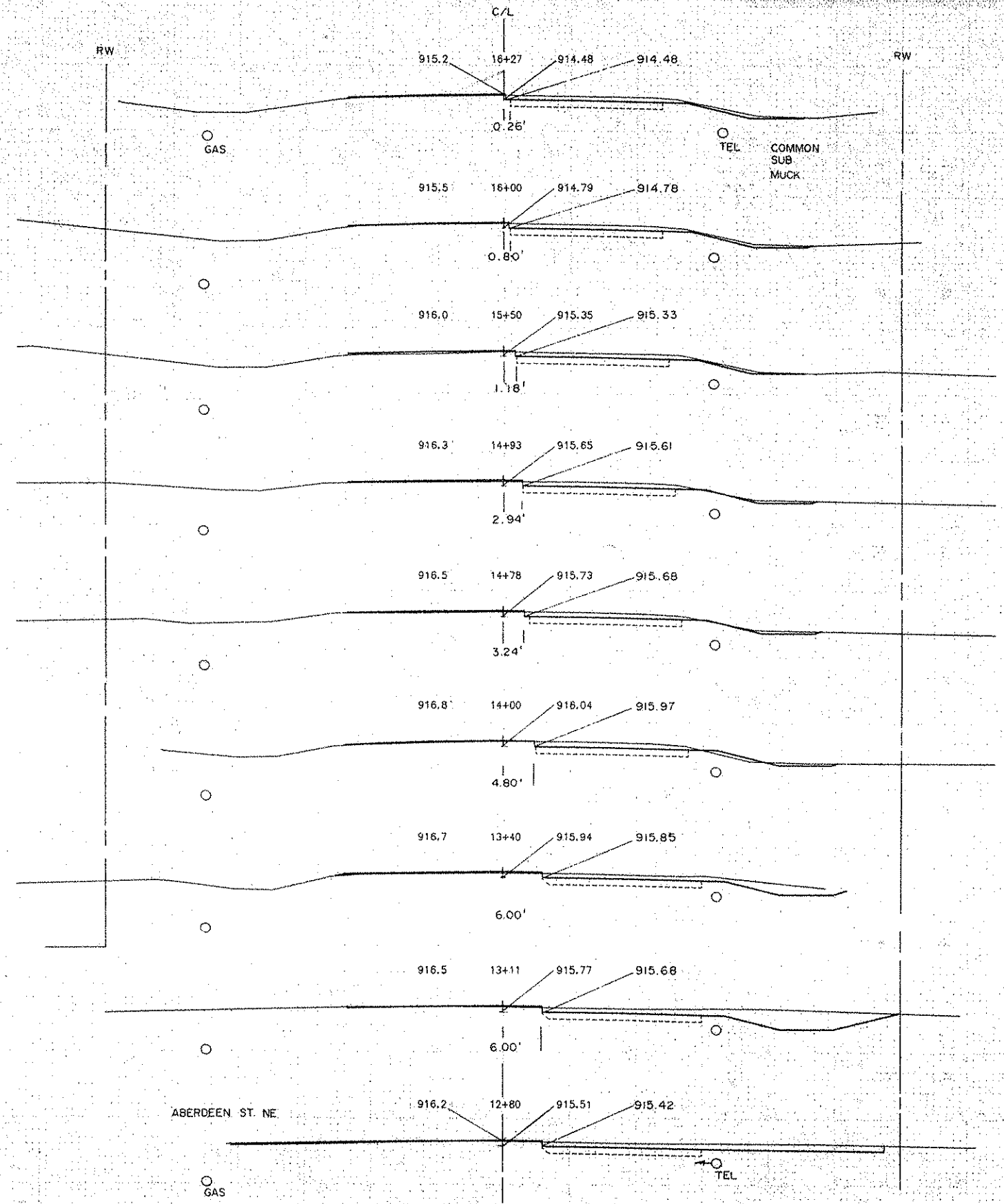

EXCAVATION EMBANKMENT
 SUB-TOTALS CU.YDS. SUB-TOTALS CU.YDS.

Fed. Proj. No. **EXCAVATION EMBANKMENT**
 SUB-TOTALS CU.YDS. SUB-TOTALS CU.YDS.

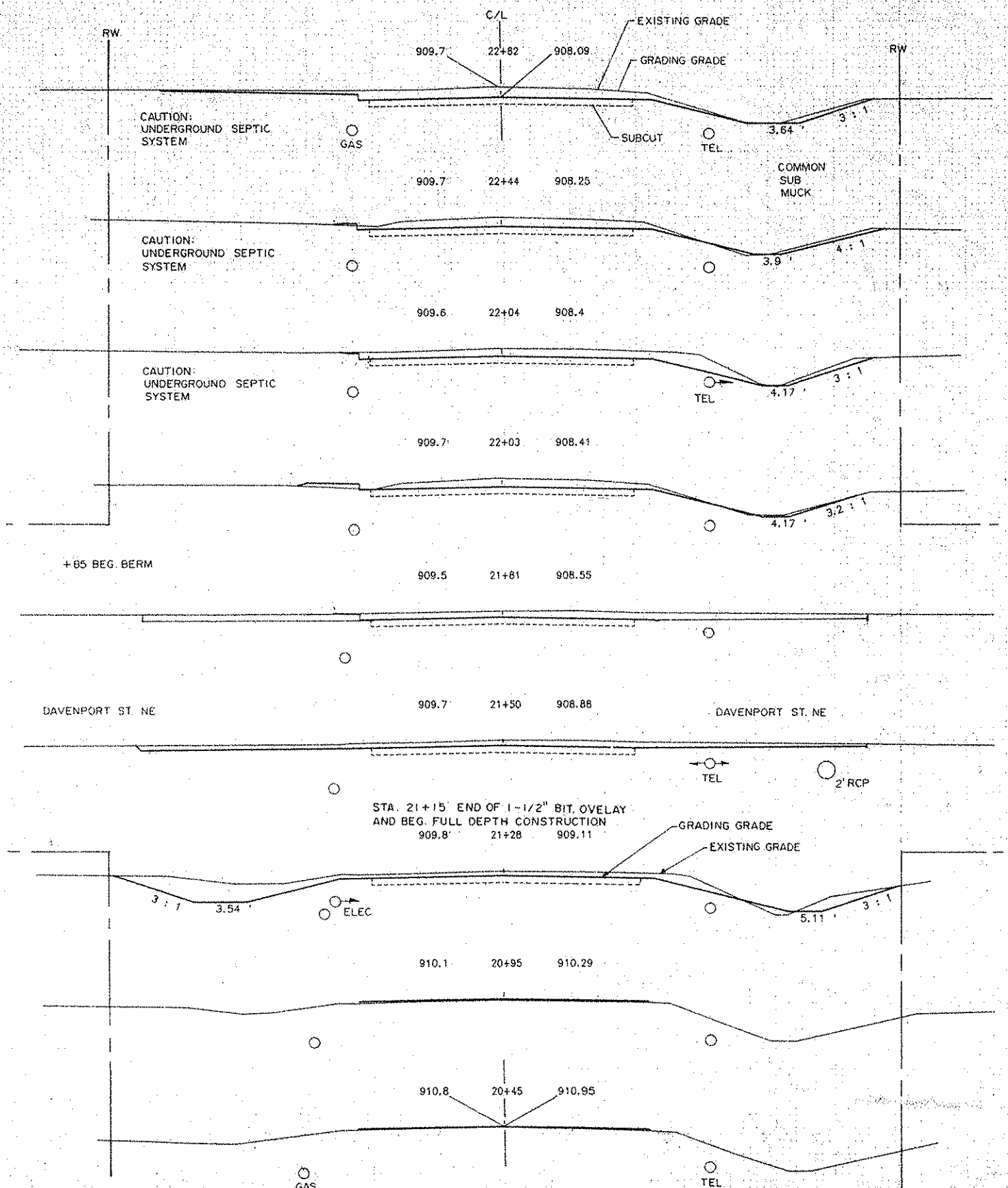
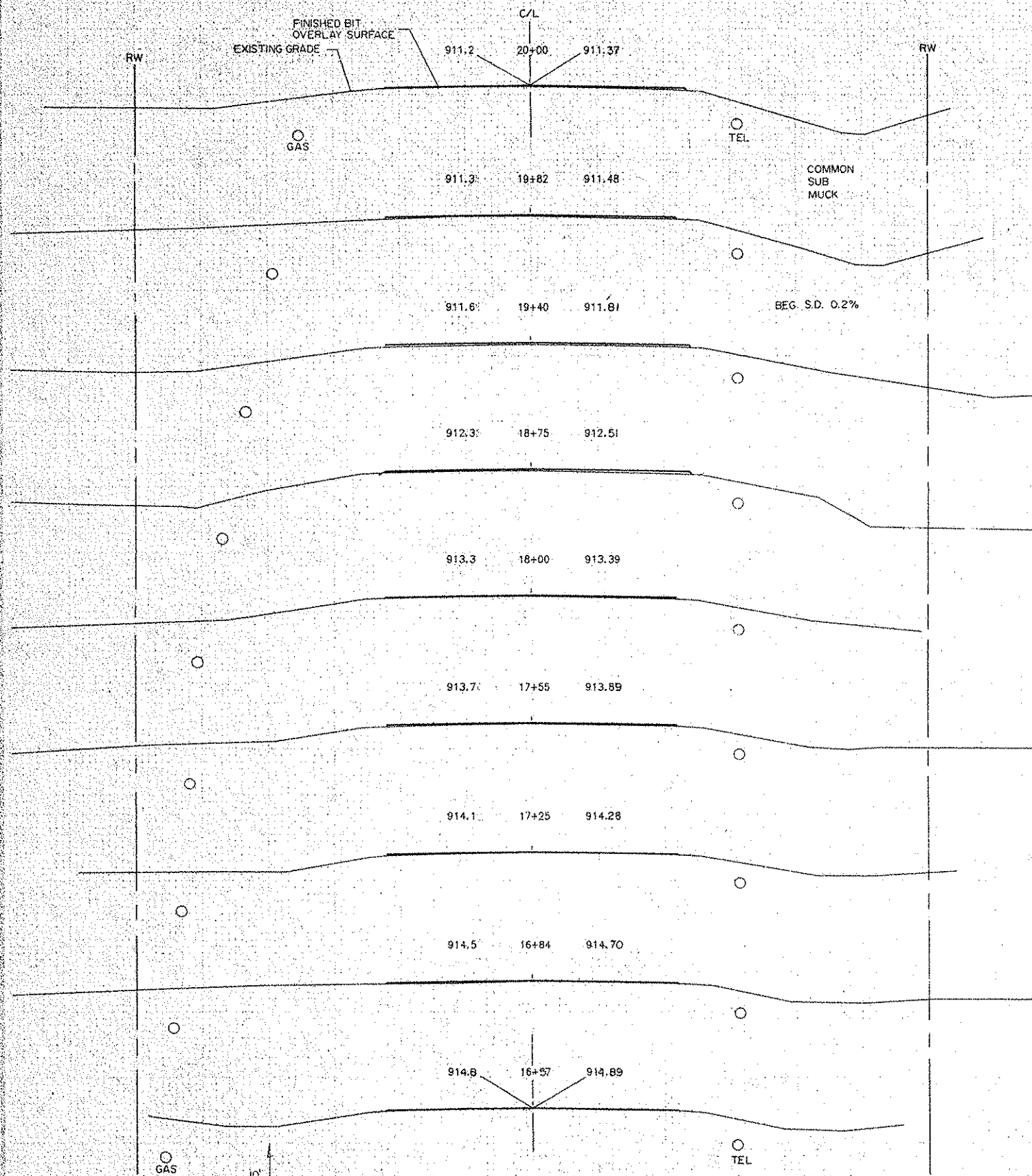

NOTE:
 UTILITY ELEVATIONS ASSUMED
 NOT ACTUAL

CROSS SECTIONS
 STA 16+27 TO STA. 22+82

EXCAVATION EMBANKMENT
 SUB-TOTALS CU.YDS. SUB-TOTALS CU.YDS.

Fed. Proj. No.

EXCAVATION EMBANKMENT
 SUB-TOTALS CU.YDS. SUB-TOTALS CU.YDS.

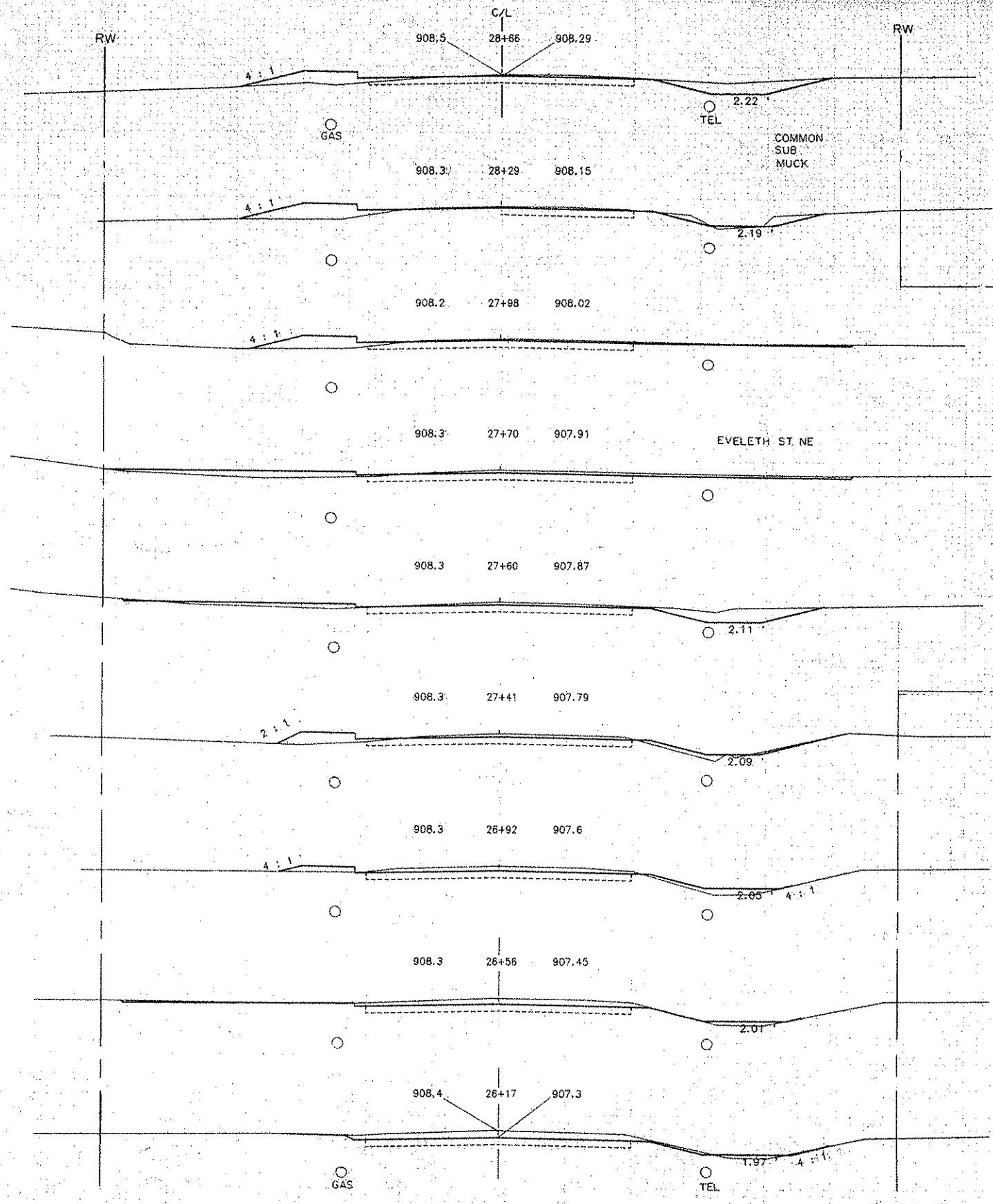
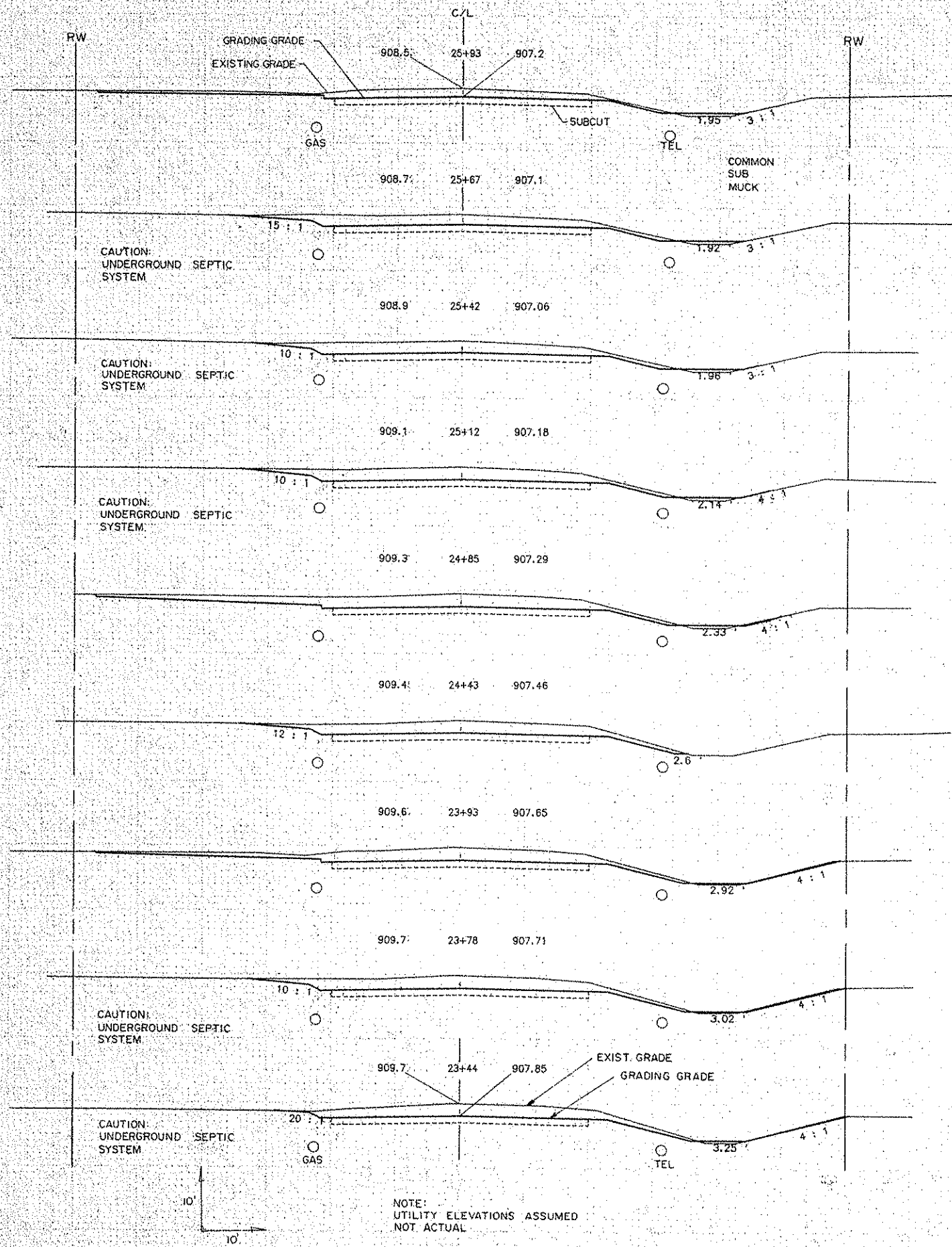

NOTE:
 UTILITY ELEVATIONS ASSUMED
 NOT ACTUAL

EXCAVATION EMBANKMENT
SUB-TOTALS CU.YDS. SUB-TOTALS CU.YDS.

Field Proj. No.

EXCAVATION EMBANKMENT
SUB-TOTALS CU.YDS. SUB-TOTALS CU.YDS.

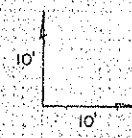
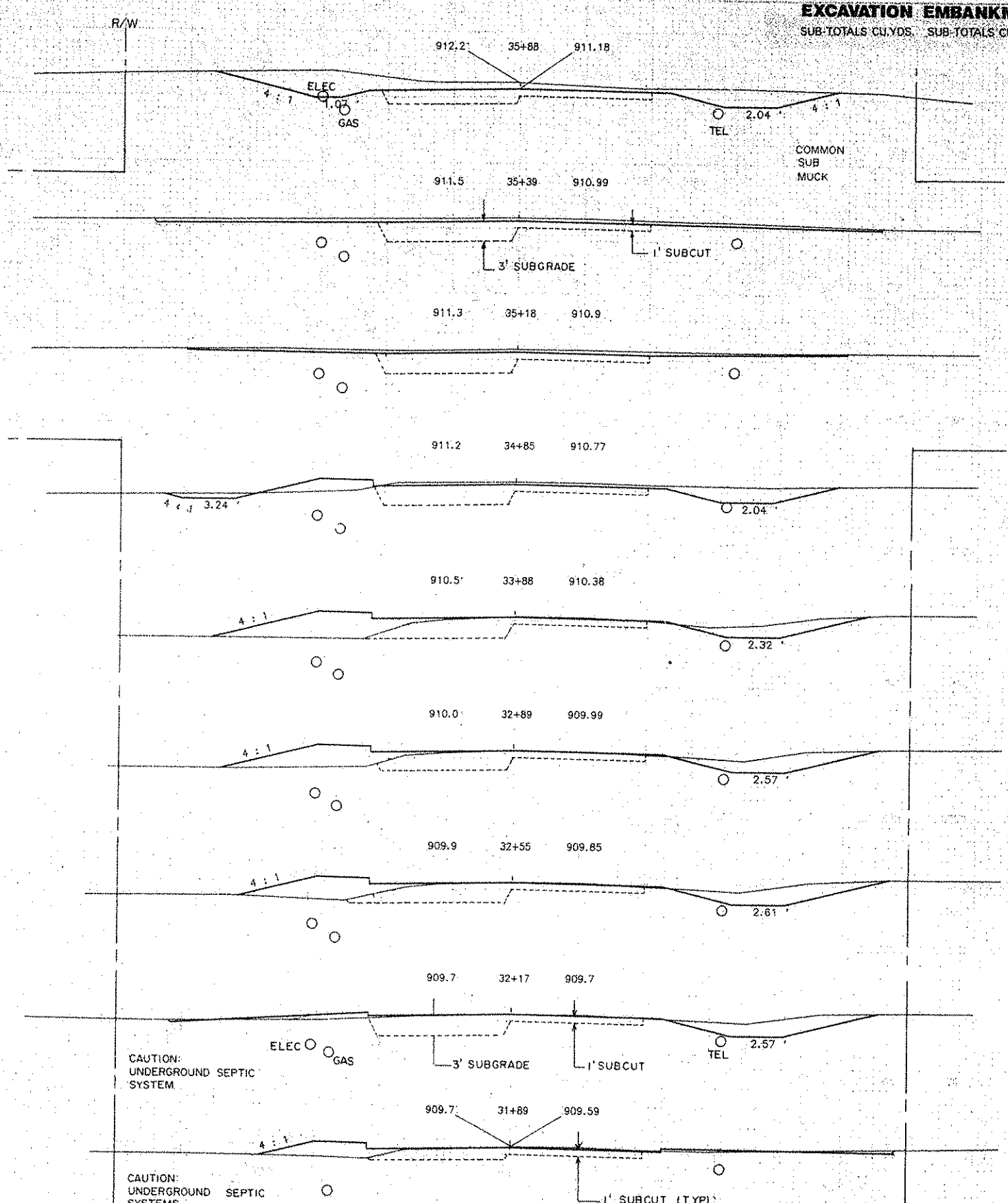
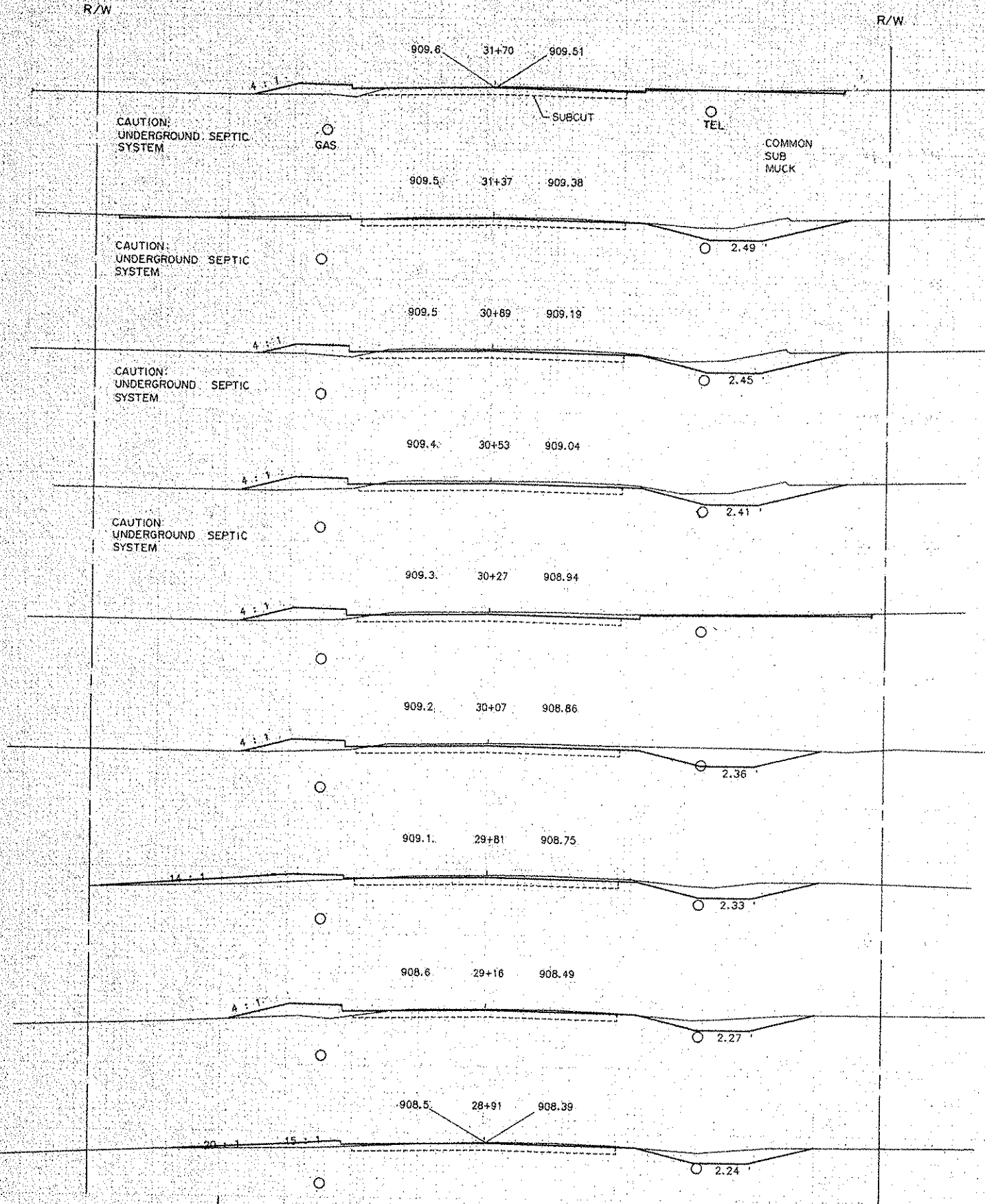

NOTE:
UTILITY ELEVATIONS ASSUMED
NOT ACTUAL

EXCAVATION EMBANKMENT
SUB-TOTALS CU. YDS. SUB-TOTALS CU. YDS.

Fed. Proj. No. **EXCAVATION EMBANKMENT**
SUB-TOTALS CU. YDS. SUB-TOTALS CU. YDS.

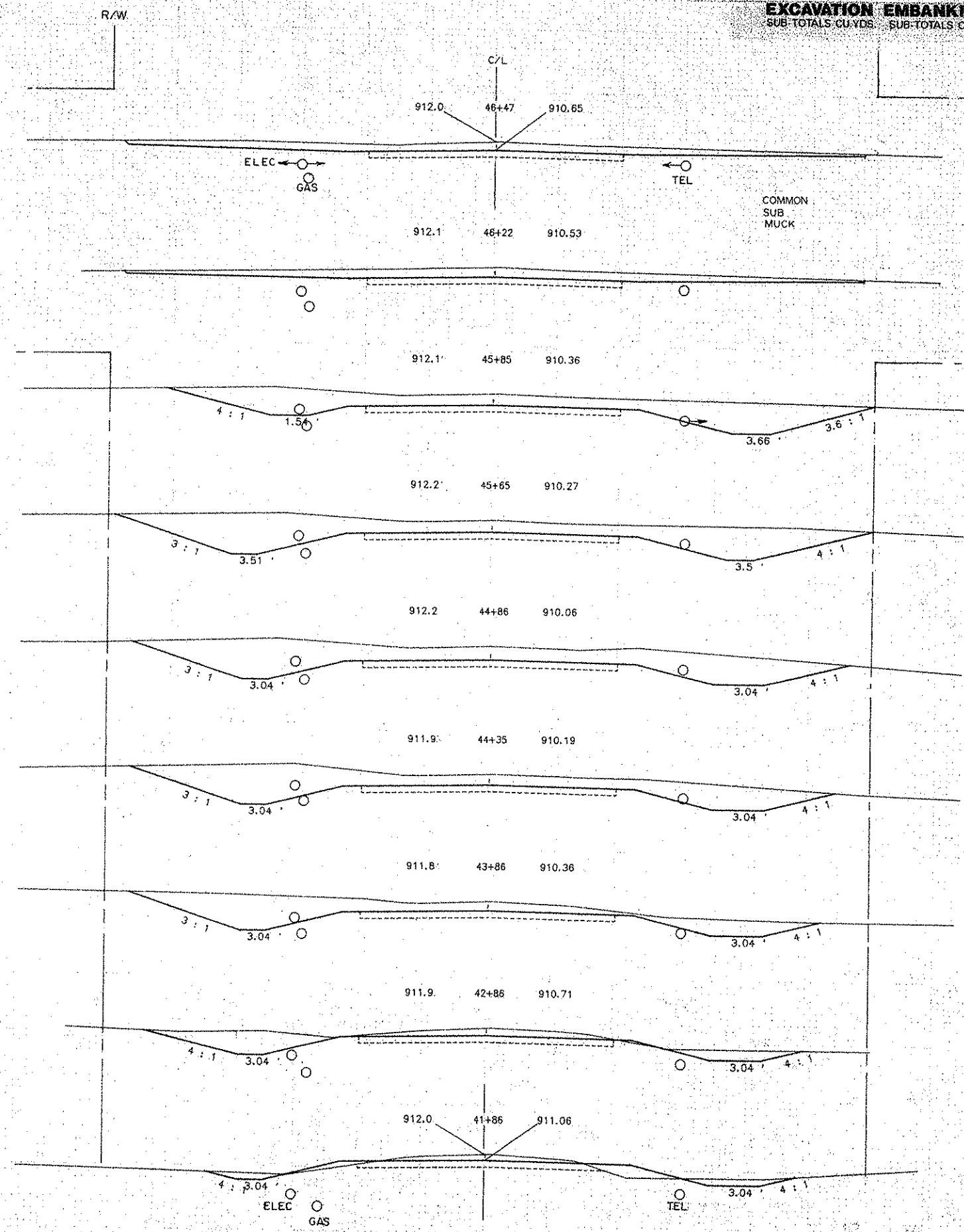
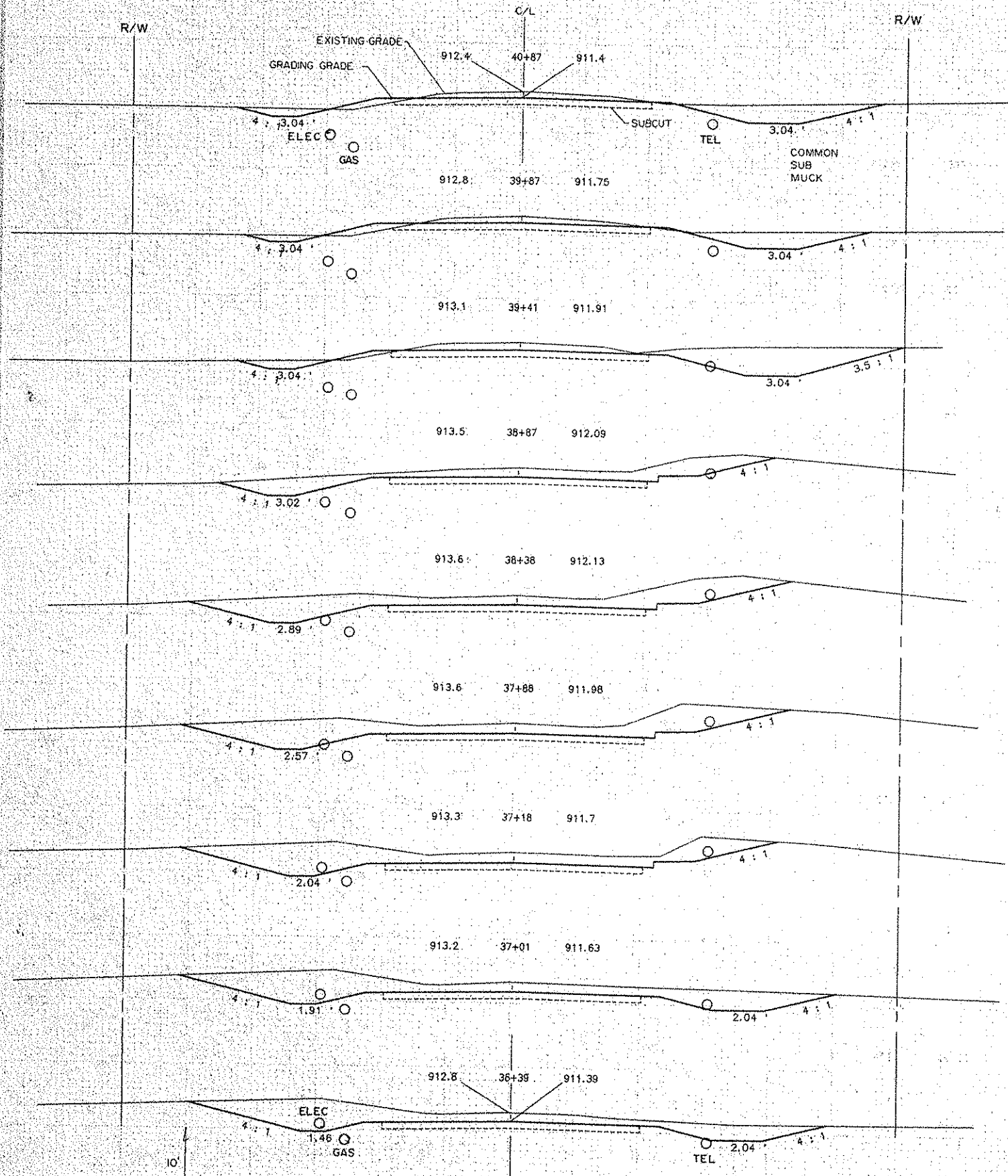

NOTE:
UTILITY ELEVATIONS ASSUMED
NOT ACTUAL

CROSS-SECTIONS
STA. 36+39 TO STA. 46+47

Co. Proj. No. 93-04-60

Sheet No. 30 of 42 Sheets

EXCAVATION EMBANKMENT
 SUB-TOTALS CU.YDS. SUB-TOTALS CU.YDS.

Fed. Proj. No.

EXCAVATION EMBANKMENT
 SUB-TOTALS CU.YDS. SUB-TOTALS CU.YDS.

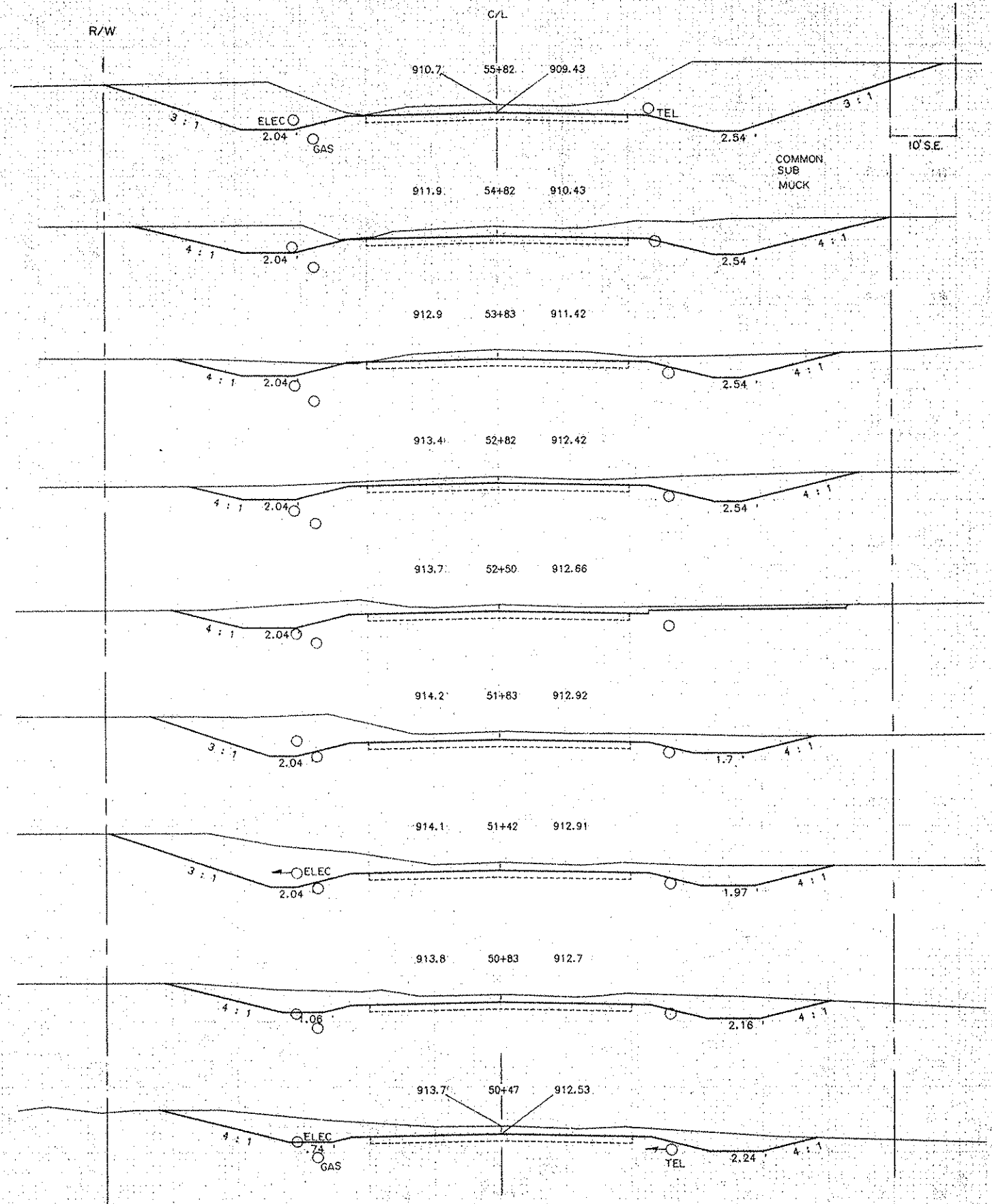
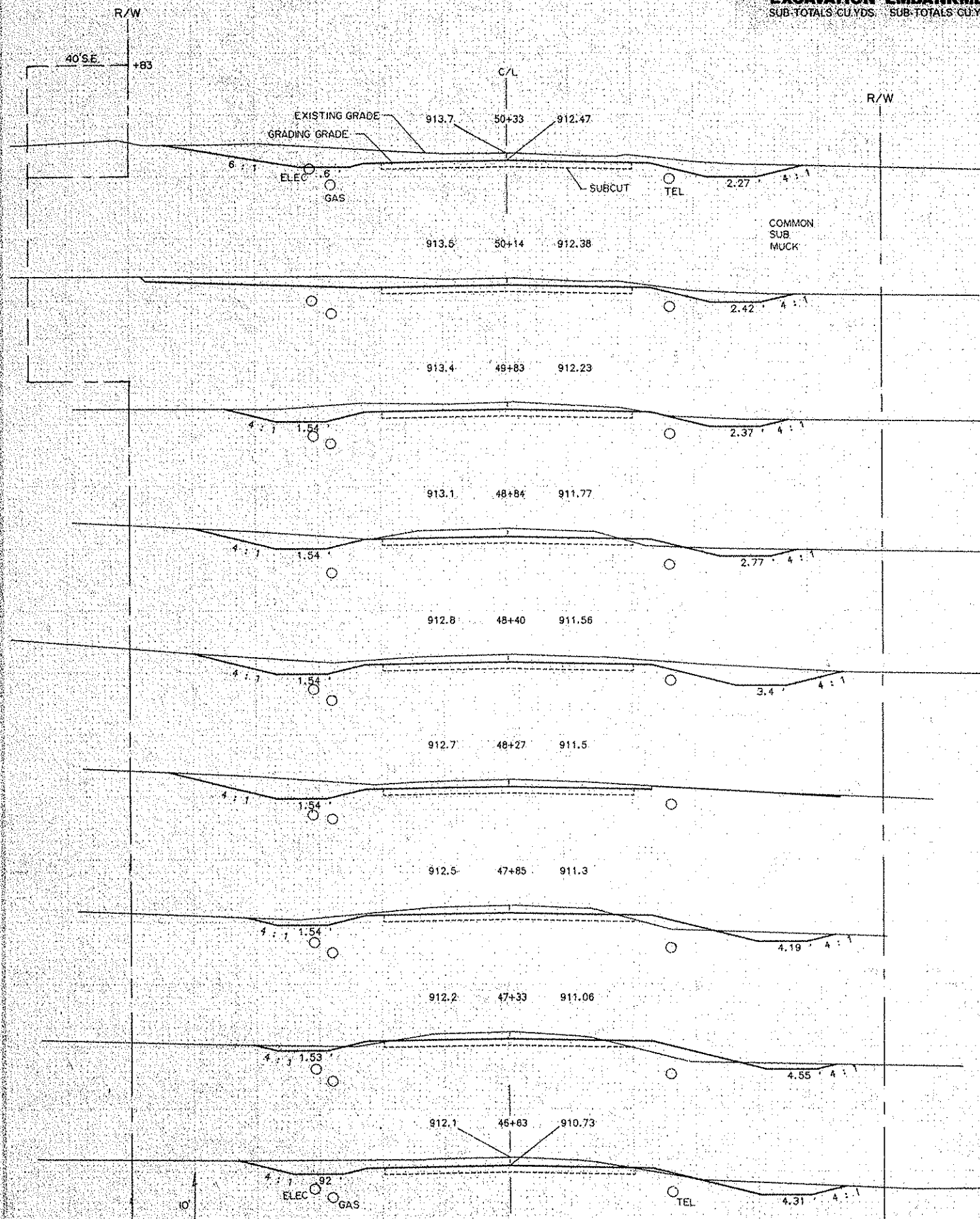

NOTE:
 UTILITY ELEVATIONS ASSUMED
 NOT ACTUAL

CROSS-SECTIONS
 STA. 46+63 TO STA. 55+82

Co. Proj. No. 93-04-60

Sheet No. 31 of 42 Sheets

EXCAVATION EMBANKMENT
 SUB-TOTALS CU.YDS. SUB-TOTALS CU.YDS.

Proj. No. **EXCAVATION EMBANKMENT**
 SUB-TOTALS CU.YDS. SUB-TOTALS CU.YDS.

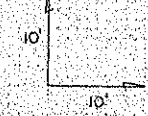
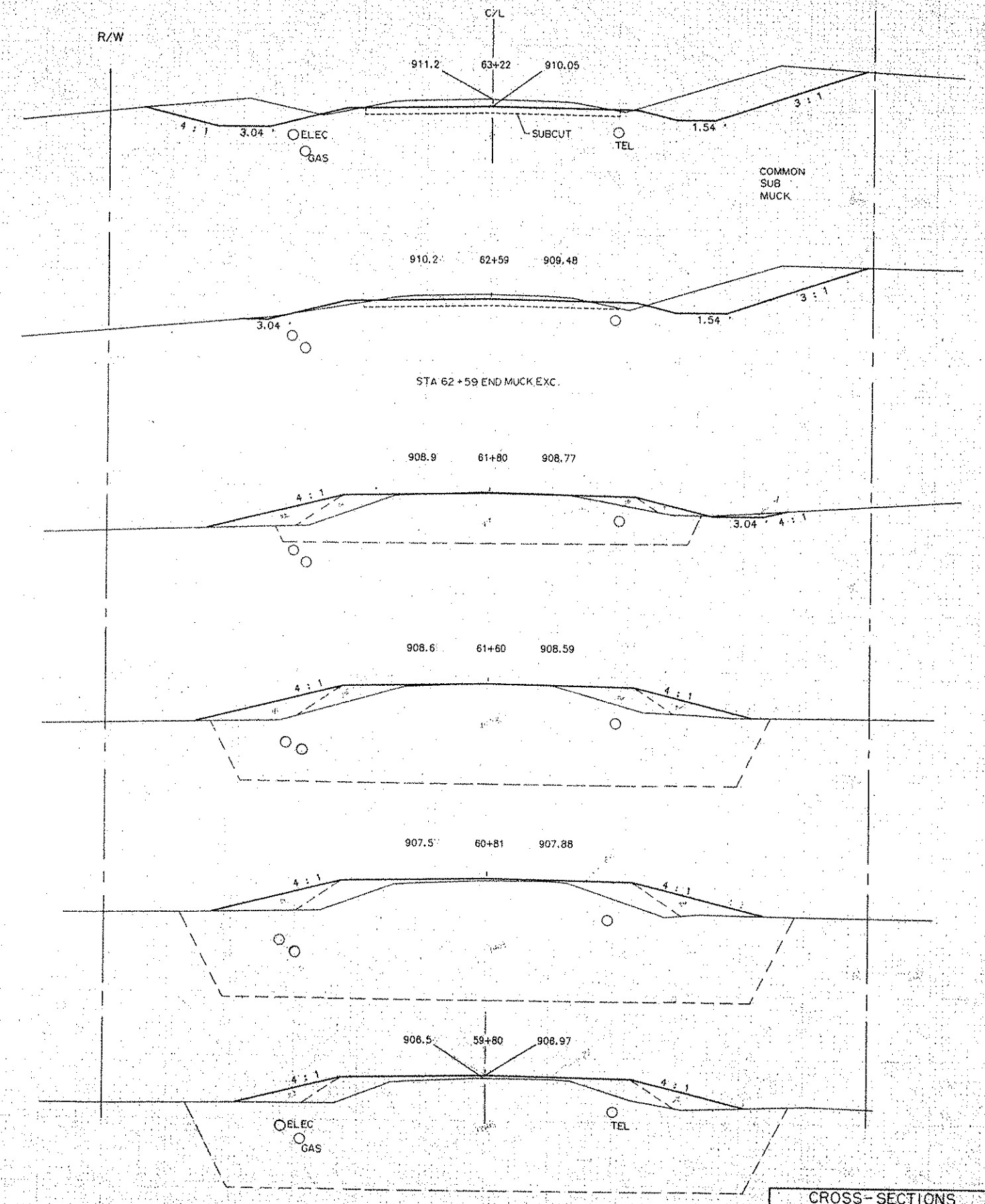
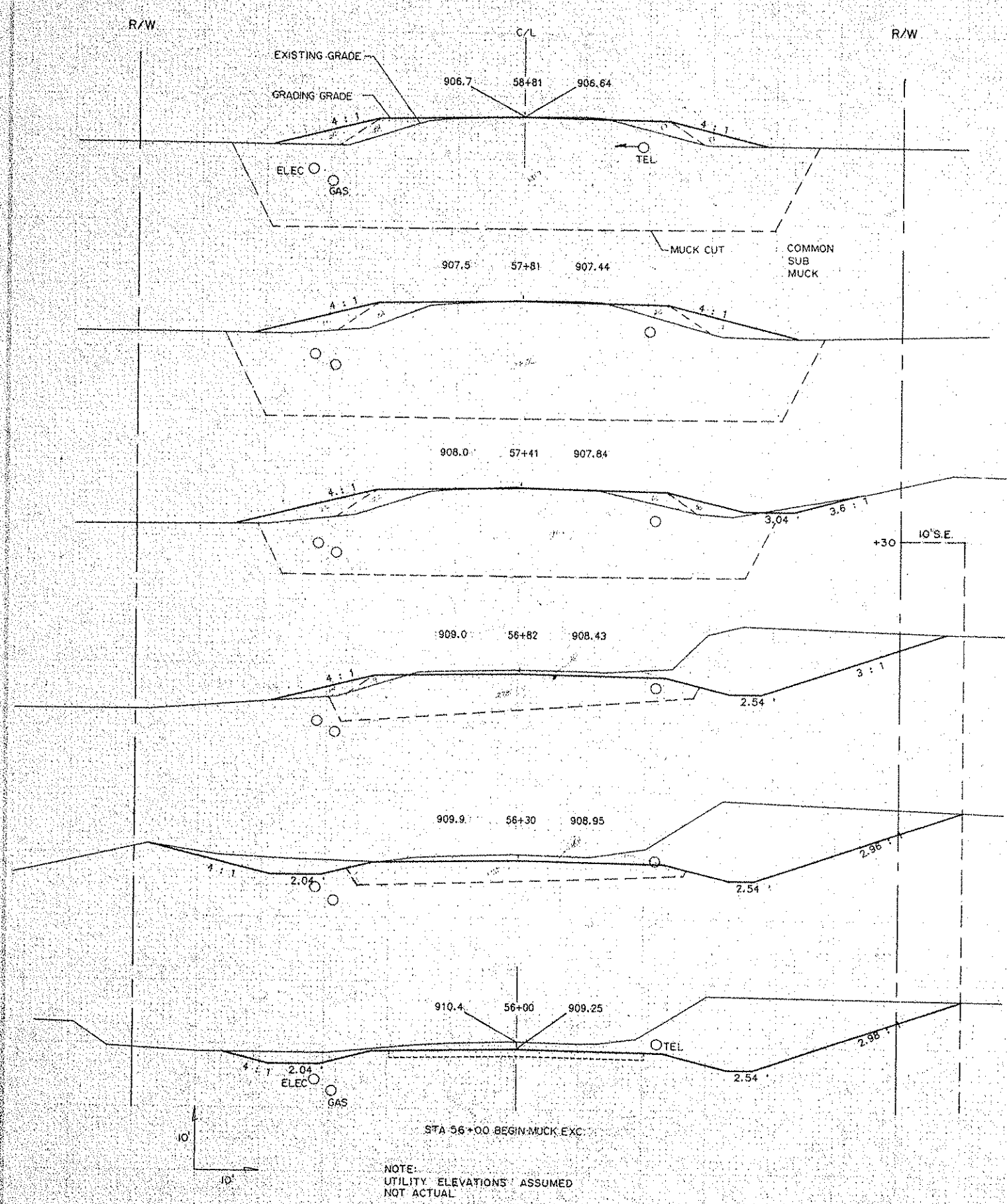

NOTE:
 UTILITY ELEVATIONS ASSUMED
 NOT ACTUAL

Co. Proj. No. 93-04-60

CROSS-SECTIONS
 STA. 56+00 TO STA. 63+22
 Sheet No. 32 of 42 Sheets

EXCAVATION EMBANKMENT
 SUB-TOTALS CU. YDS. SUB-TOTALS CU. YDS.

Feet. Proj. No.

EXCAVATION EMBANKMENT
 SUB-TOTALS CU. YDS. SUB-TOTALS CU. YDS.

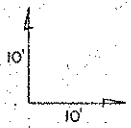
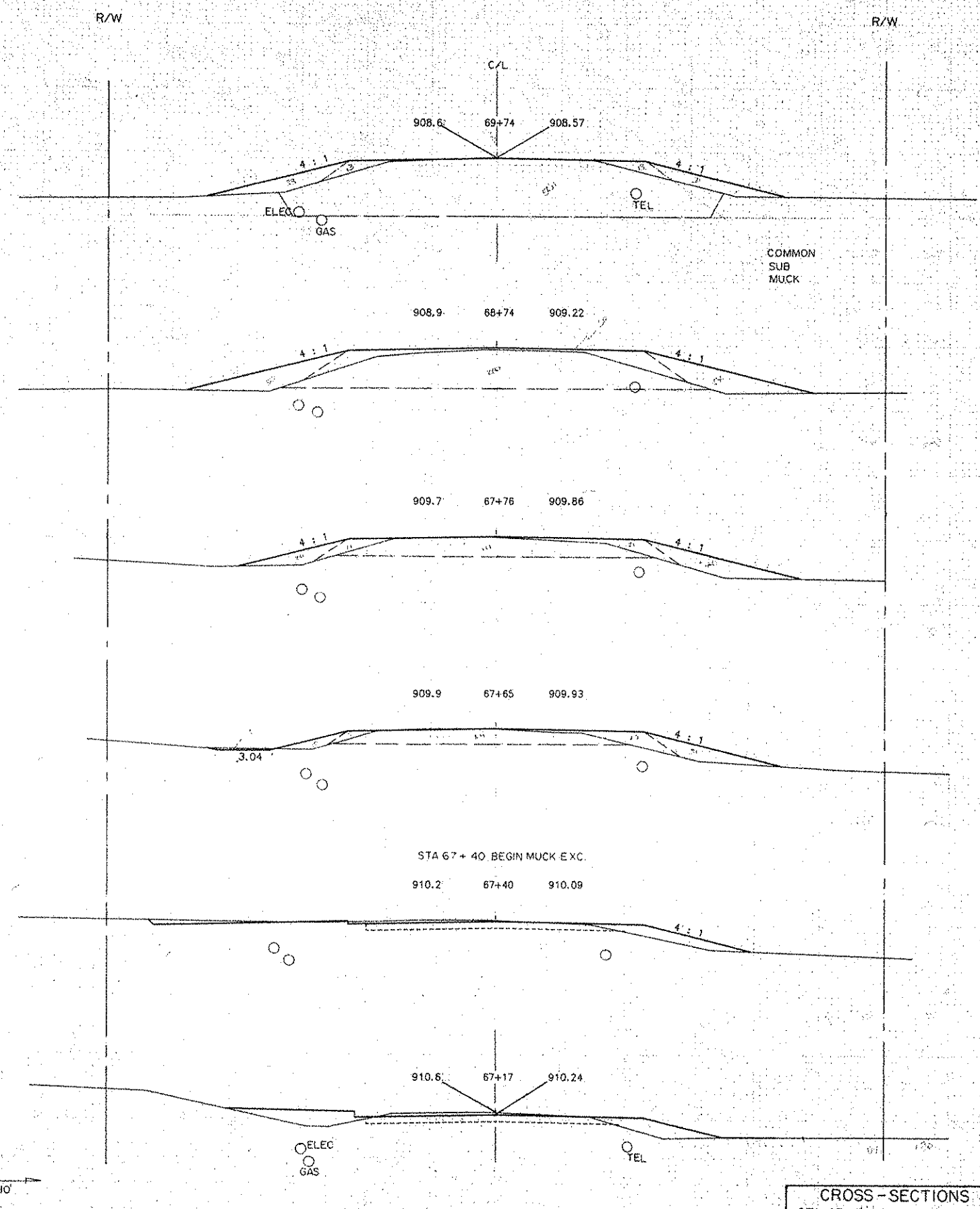
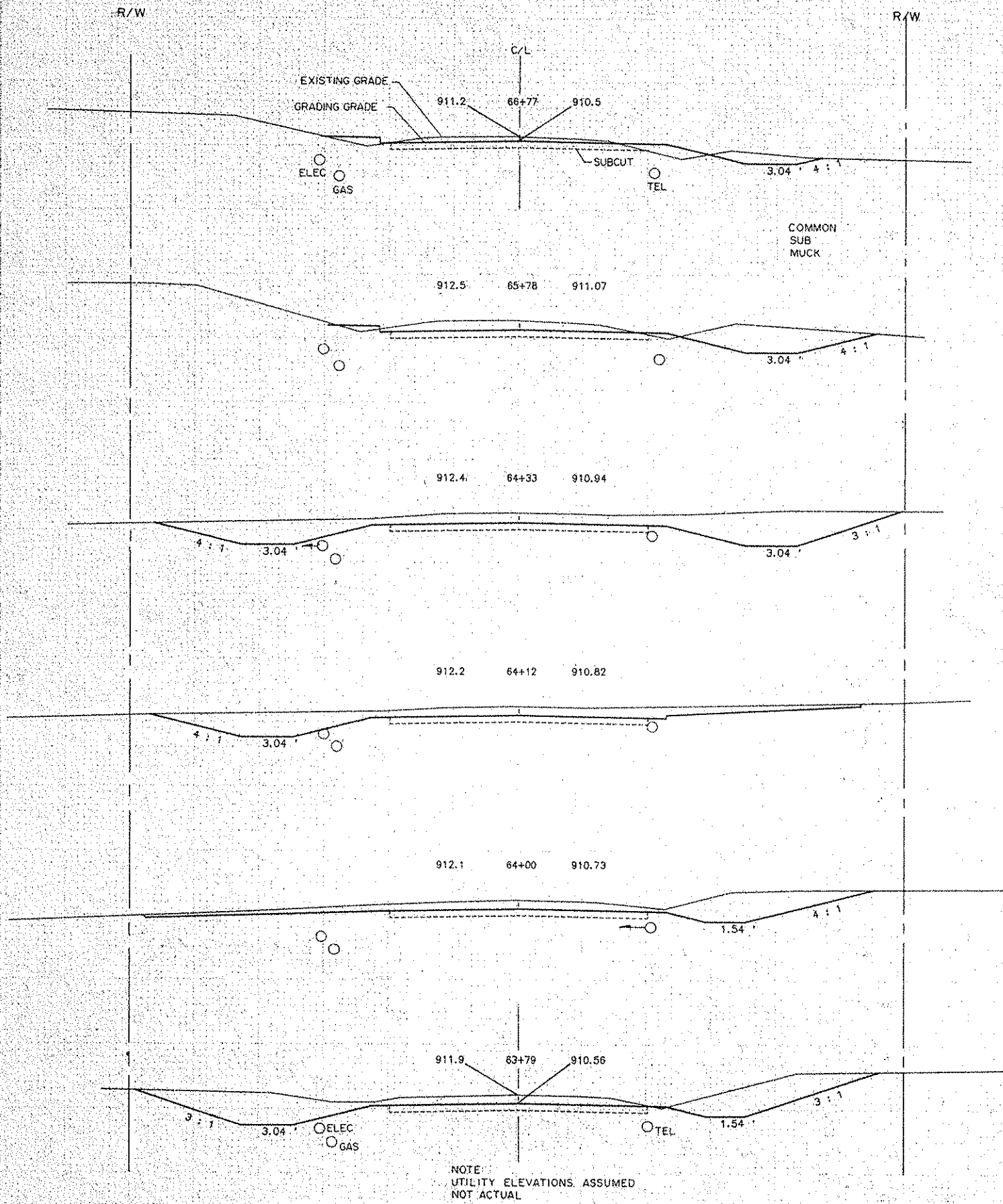

EXCAVATION EMBANKMENT
 SUB-TOTALS CU.YDS. SUB-TOTALS CU.YDS.

Fed. Proj. No. **EXCAVATION EMBANKMENT**
 SUB-TOTALS CU.YDS. SUB-TOTALS CU.YDS.

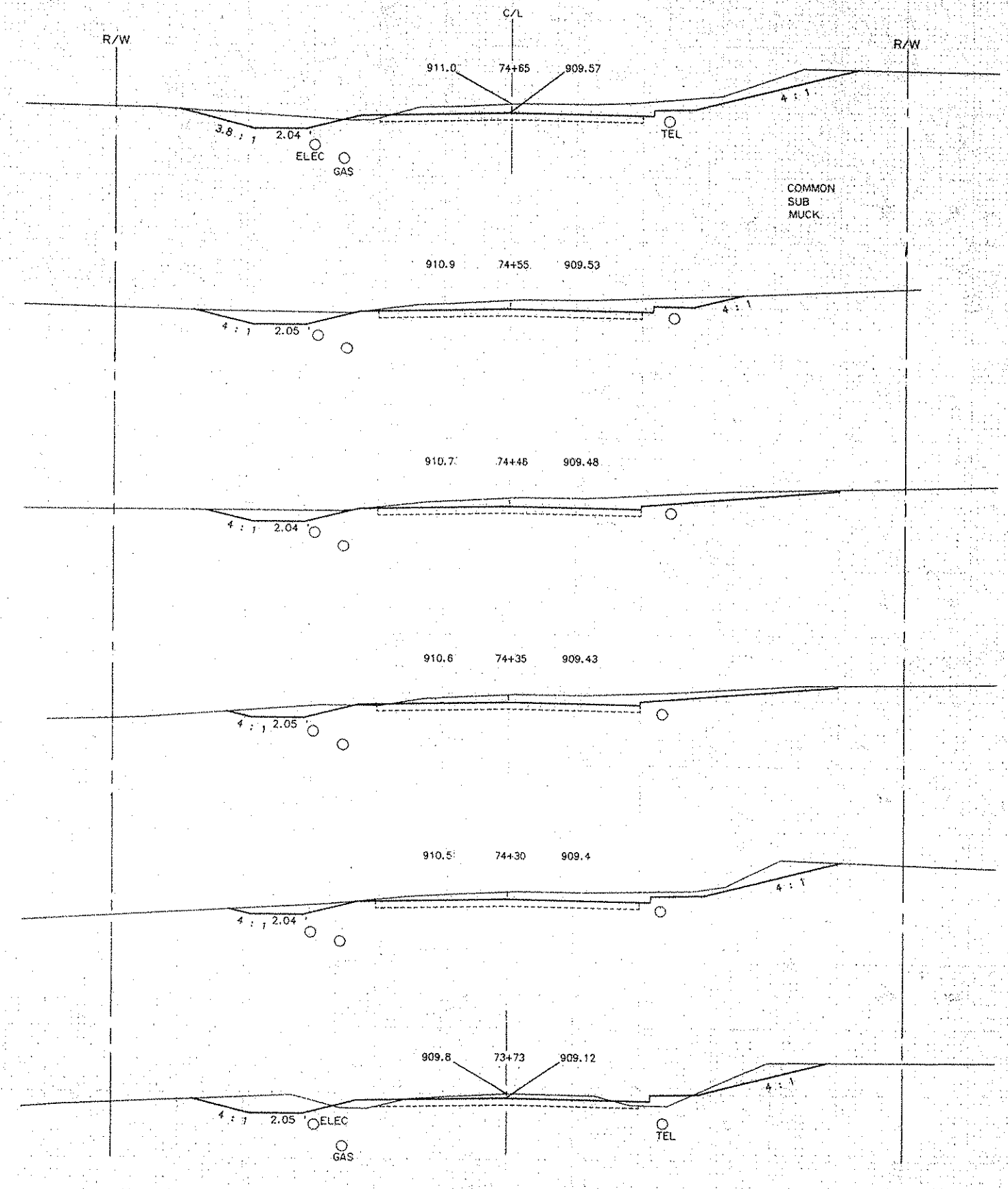
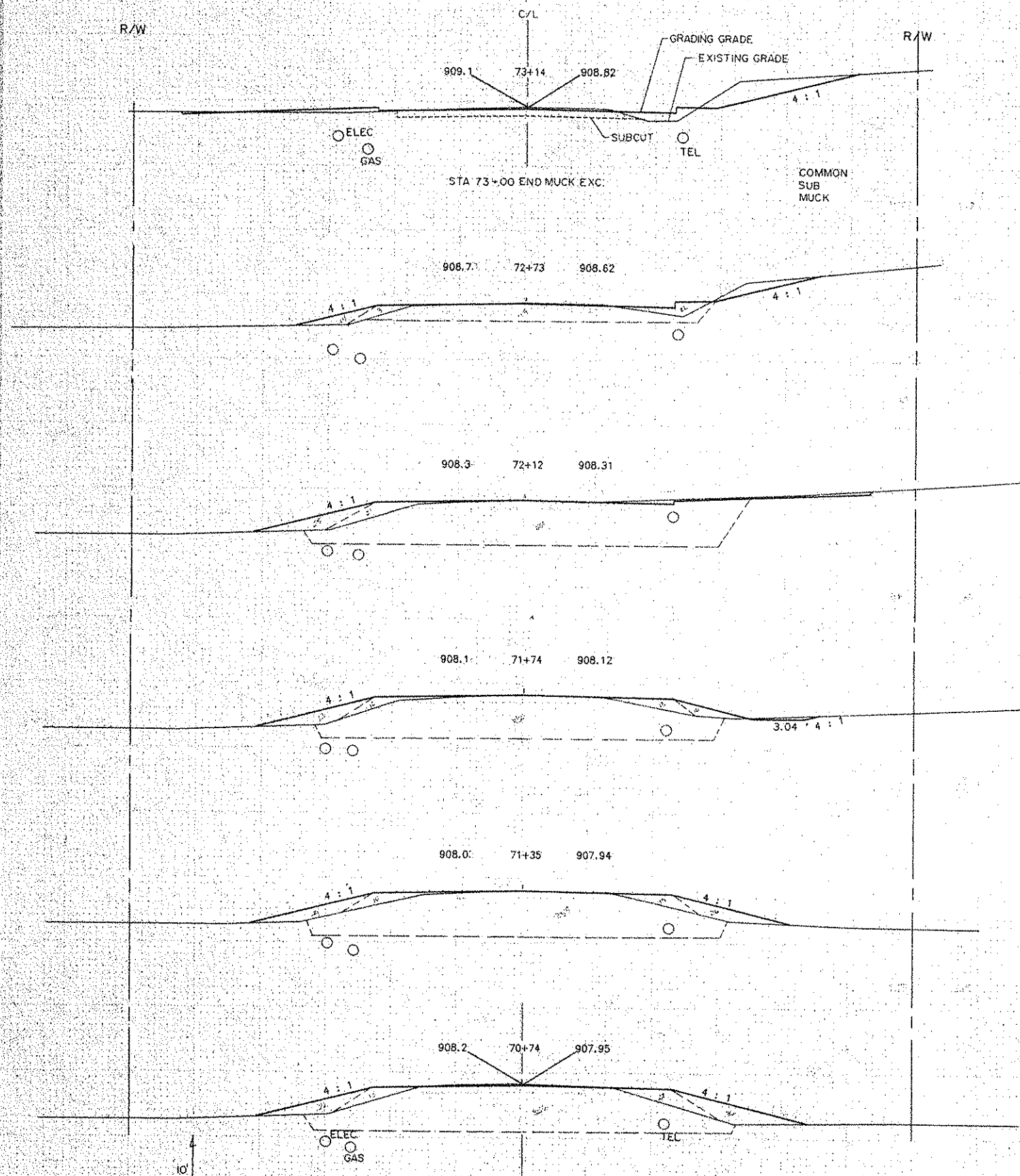

NOTE:
 UTILITY ELEVATIONS ASSUMED
 NOT ACTUAL

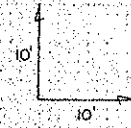

CROSS-SECTIONS
 STA. 70+74 TO STA. 74+65

EXCAVATION EMBANKMENT
 SUB-TOTALS CU.YDS. SUB-TOTALS CU.YDS.

Co. Proj. No.

EXCAVATION EMBANKMENT
 SUB-TOTALS CU.YDS. SUB-TOTALS CU.YDS.

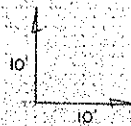
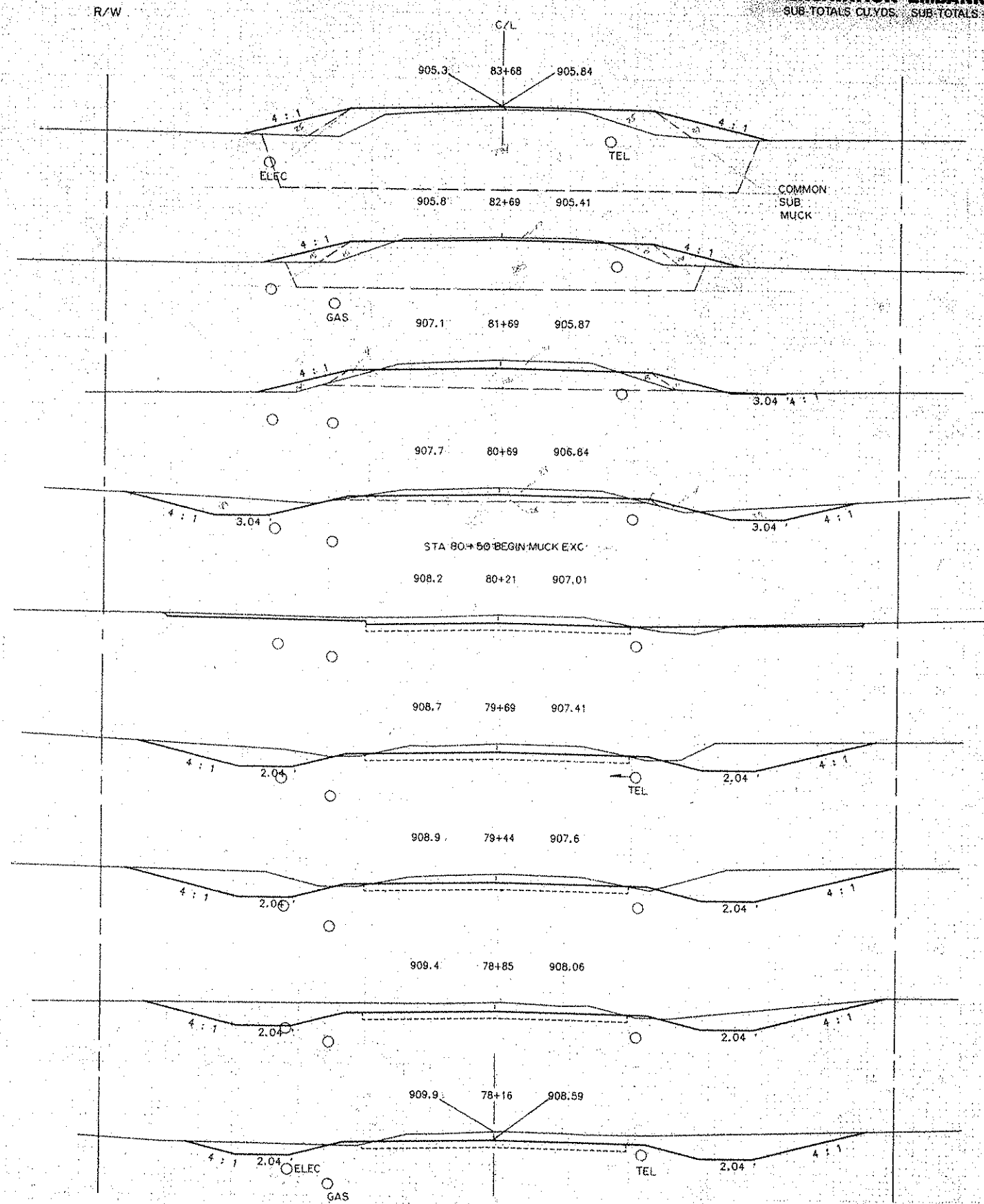
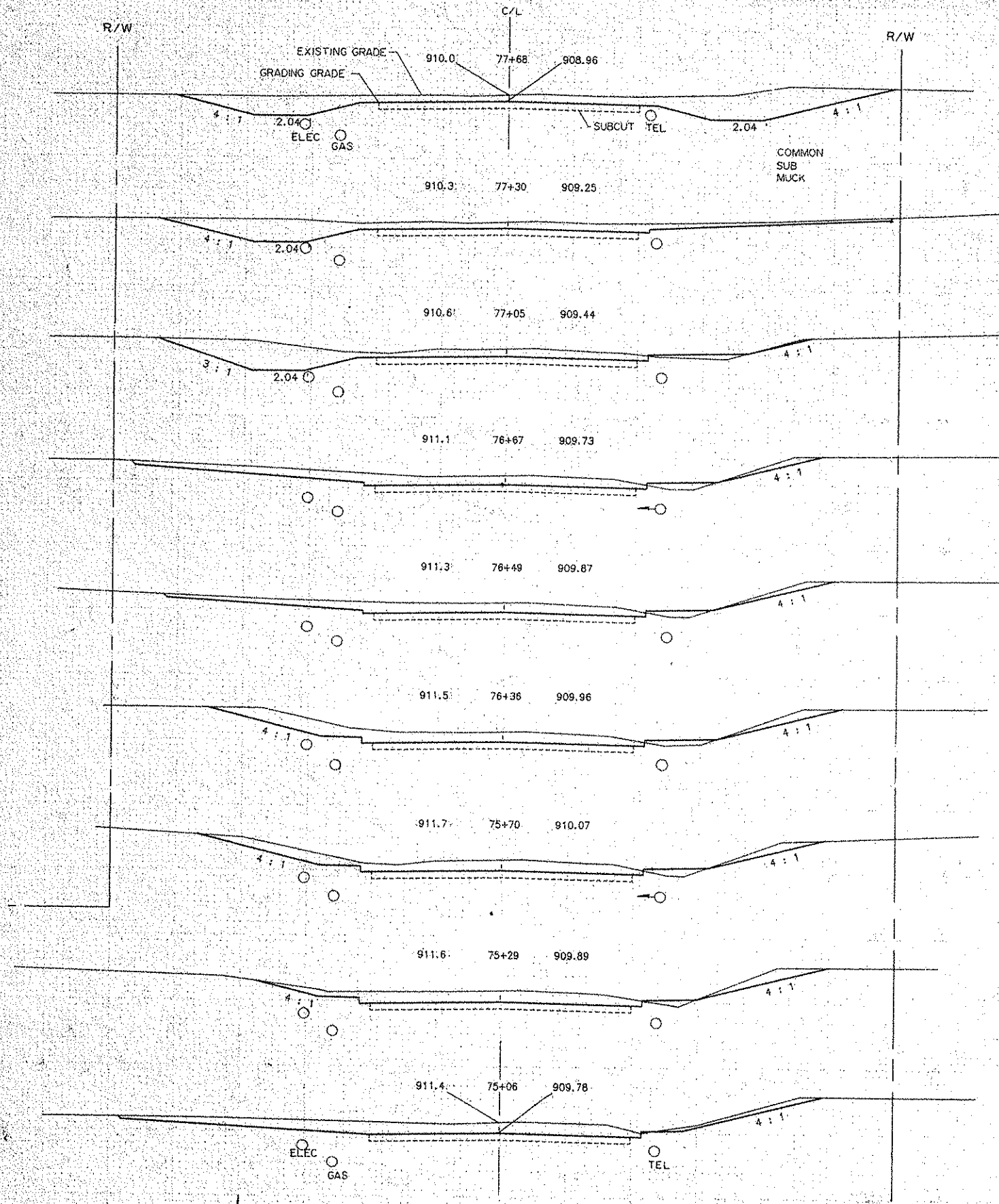

NOTE:
 UTILITY ELEVATIONS ASSUMED
 NOT ACTUAL

EXCAVATION EMBANKMENT
 SUB-TOTALS CU.YDS. SUB-TOTALS CU.YDS.

Exc. Proj. No. **EXCAVATION EMBANKMENT**
 SUB-TOTALS CU.YDS. SUB-TOTALS CU.YDS.

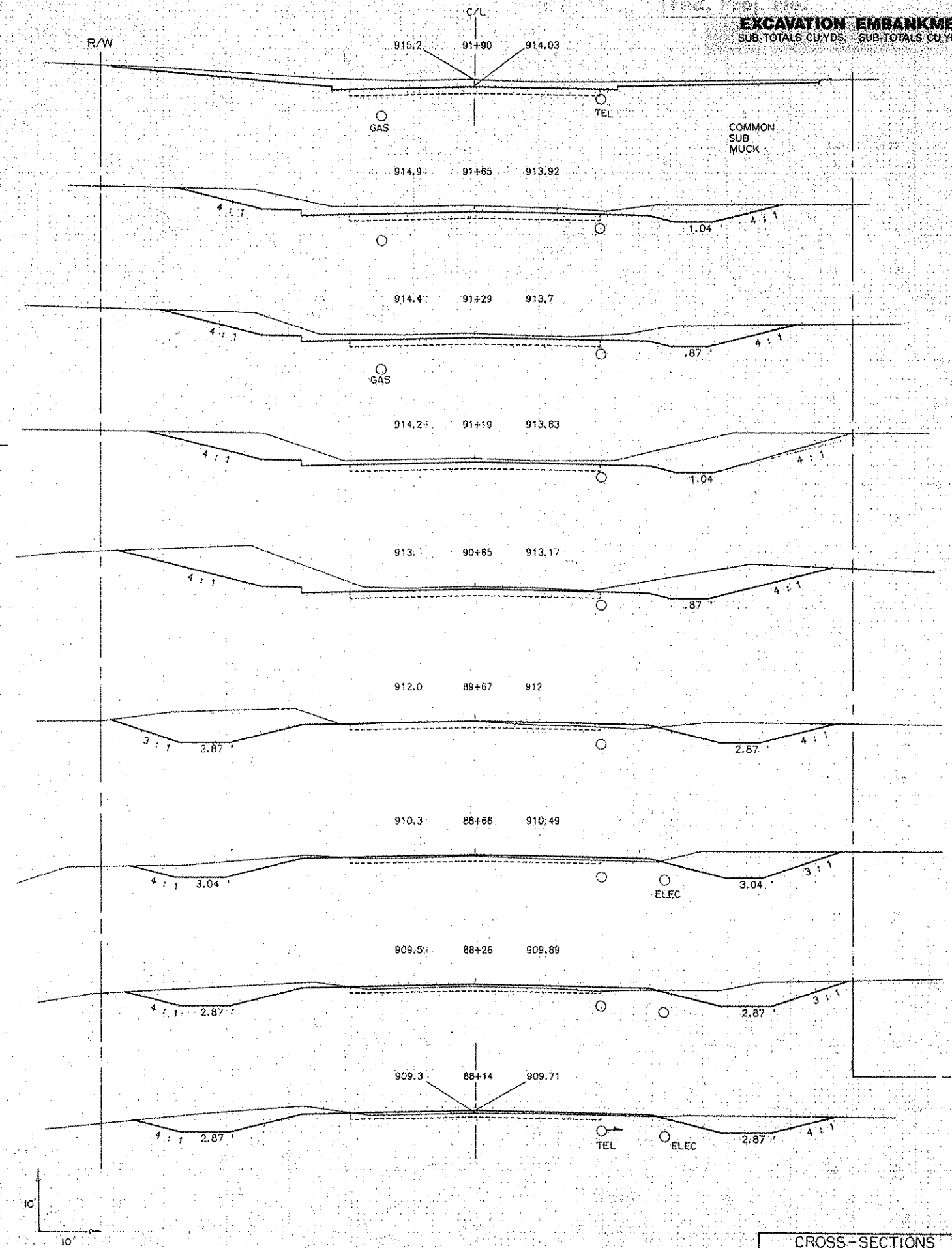
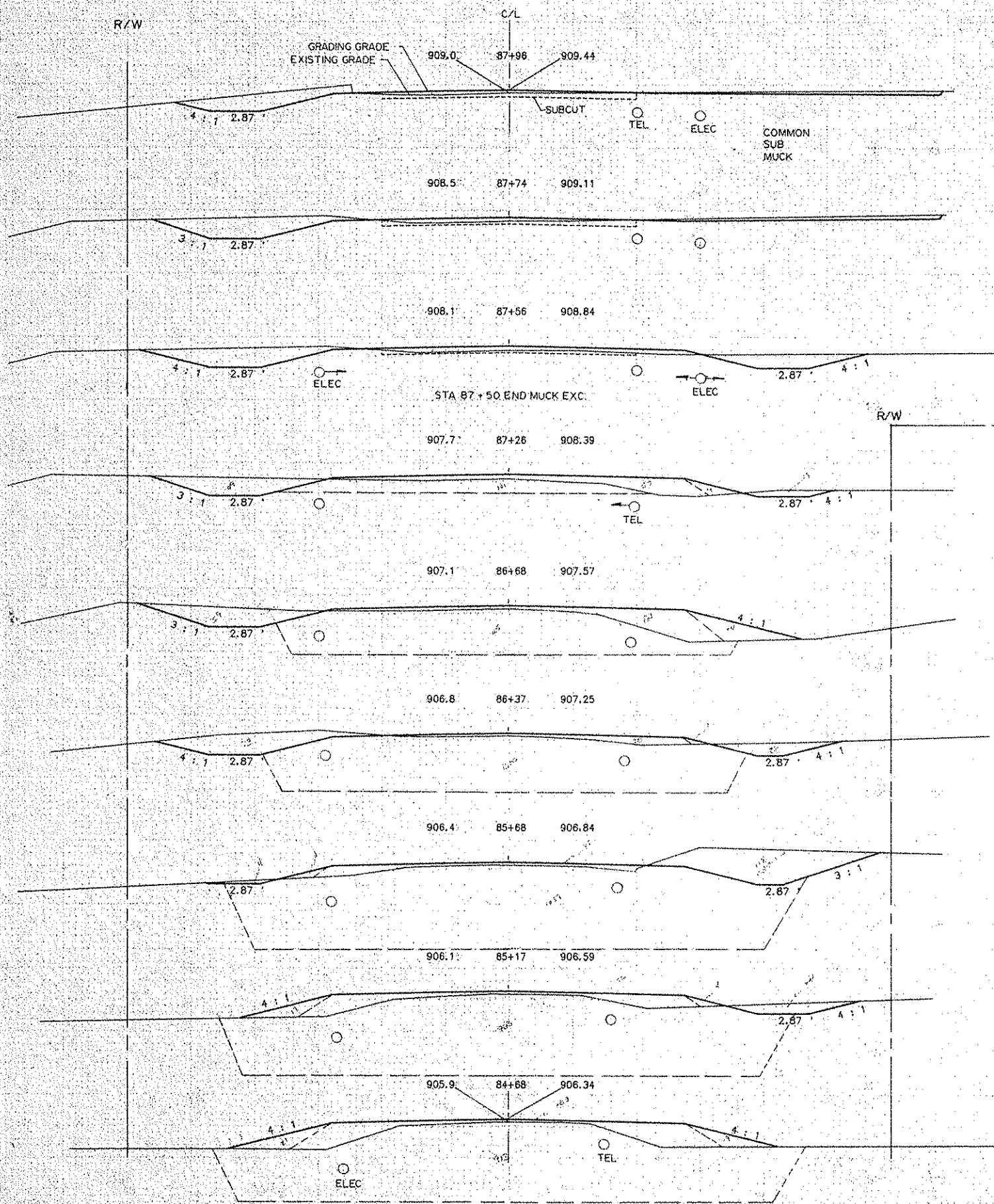

EXCAVATION EMBANKMENT
 SUB-TOTALS CU.YDS. SUB-TOTALS CU.YDS.

Proj. No. **EXCAVATION EMBANKMENT**
 SUB-TOTALS CU.YDS. SUB-TOTALS CU.YDS.

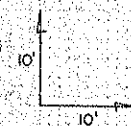
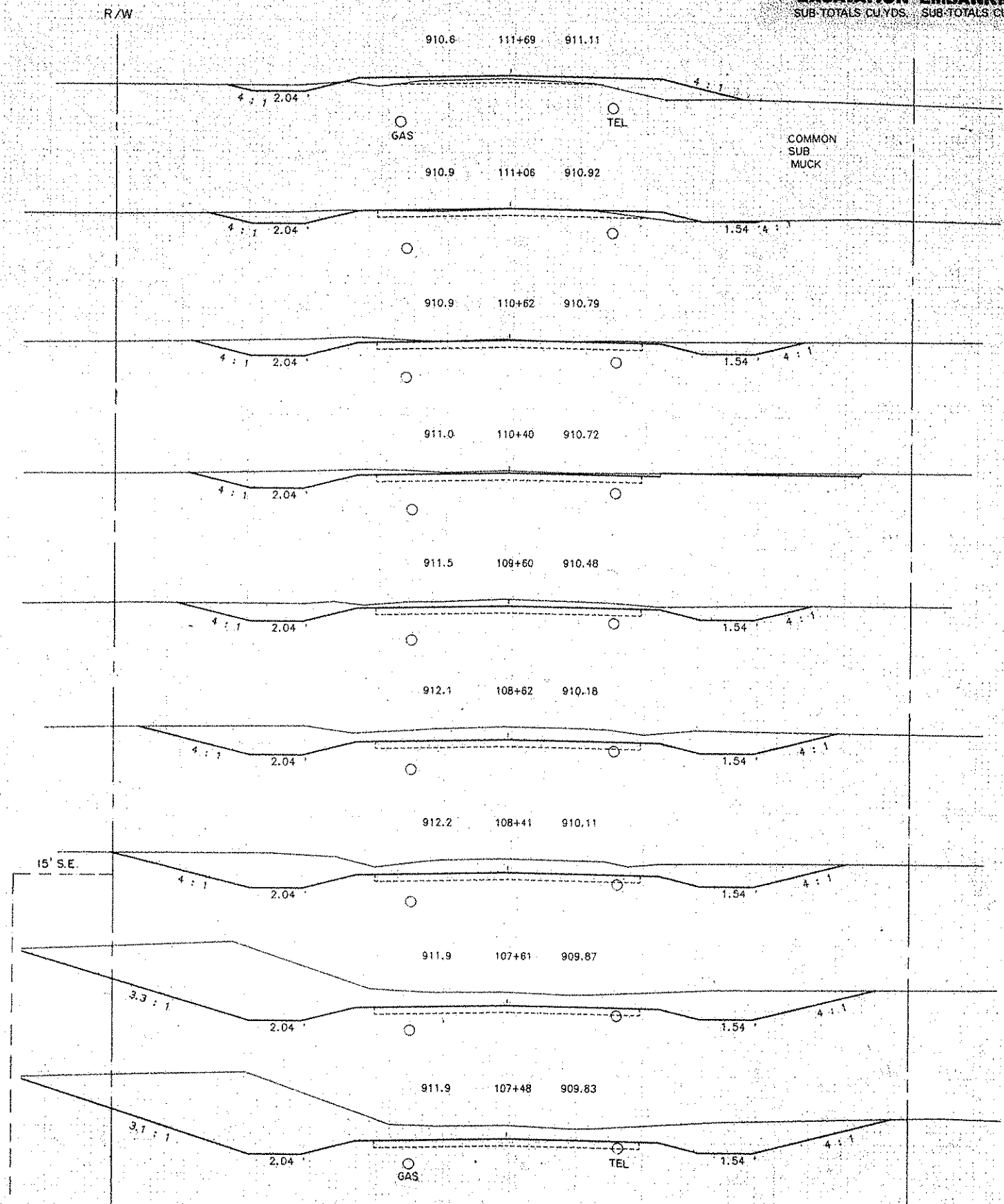
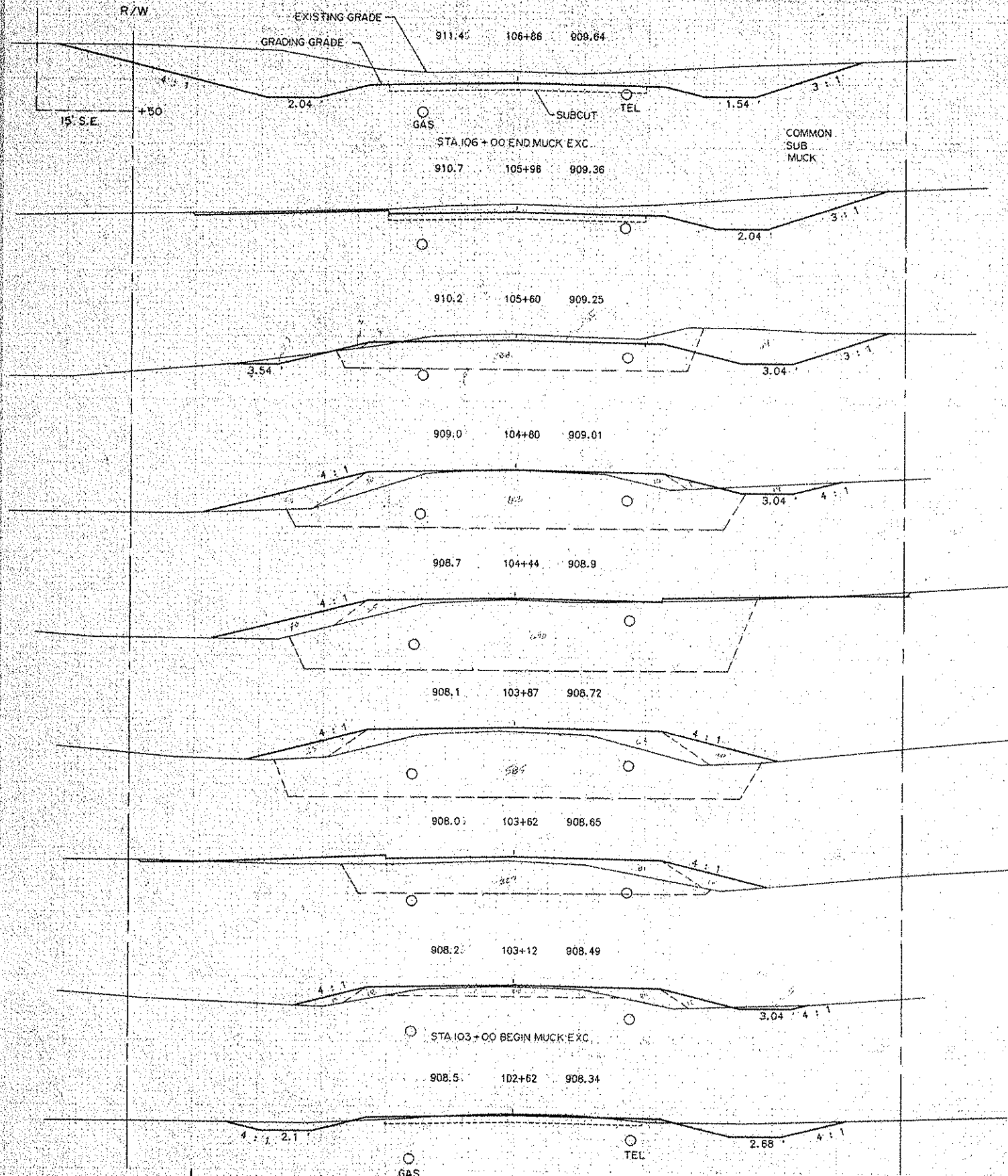

NOTE:
 UTILITY ELEVATIONS ASSUMED
 NOT ACTUAL

EXCAVATION EMBANKMENT
 SUB-TOTALS CU.YDS. SUB-TOTALS CU.YDS.

Proj. No. **EXCAVATION EMBANKMENT**
 SUB-TOTALS CU.YDS. SUB-TOTALS CU.YDS.

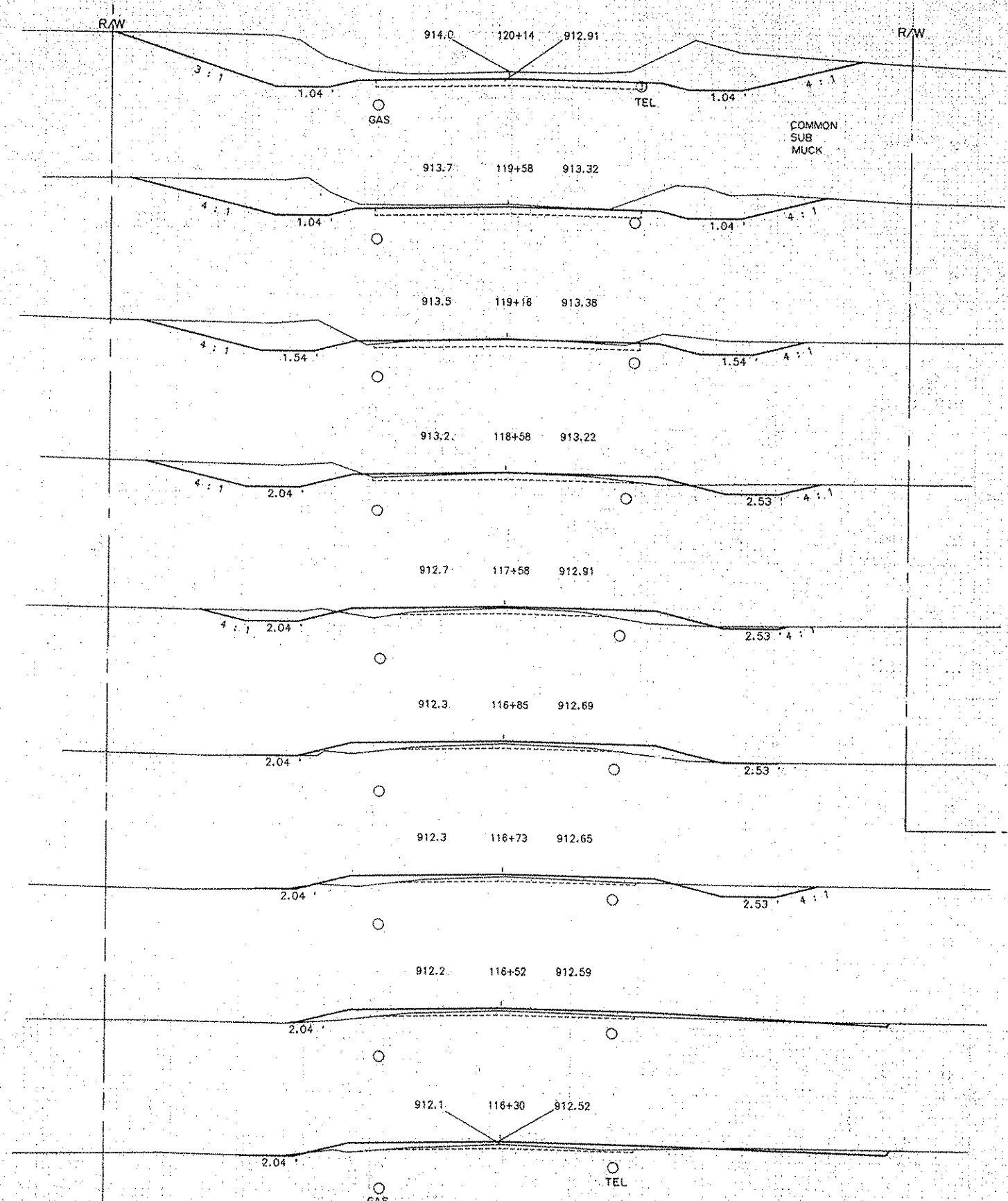
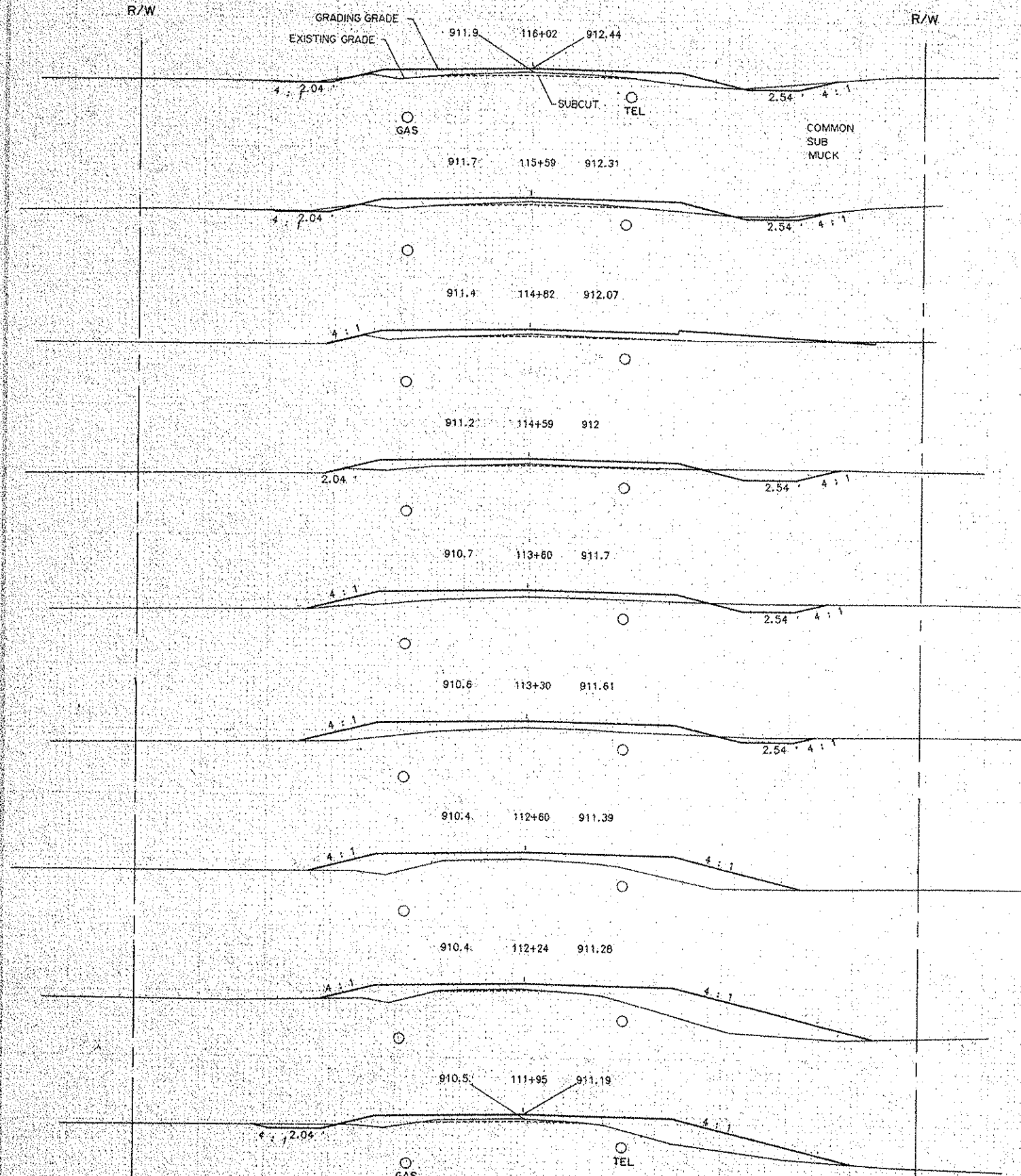

NOTE:
 UTILITY ELEVATIONS ASSUMED
 NOT ACTUAL

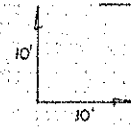

EXCAVATION EMBANKMENT
 SUB-TOTALS CU.YDS. SUB-TOTALS CU.YDS.

Dist. Proj. No. **EXCAVATION EMBANKMENT**
 SUB-TOTALS CU.YDS. SUB-TOTALS CU.YDS.

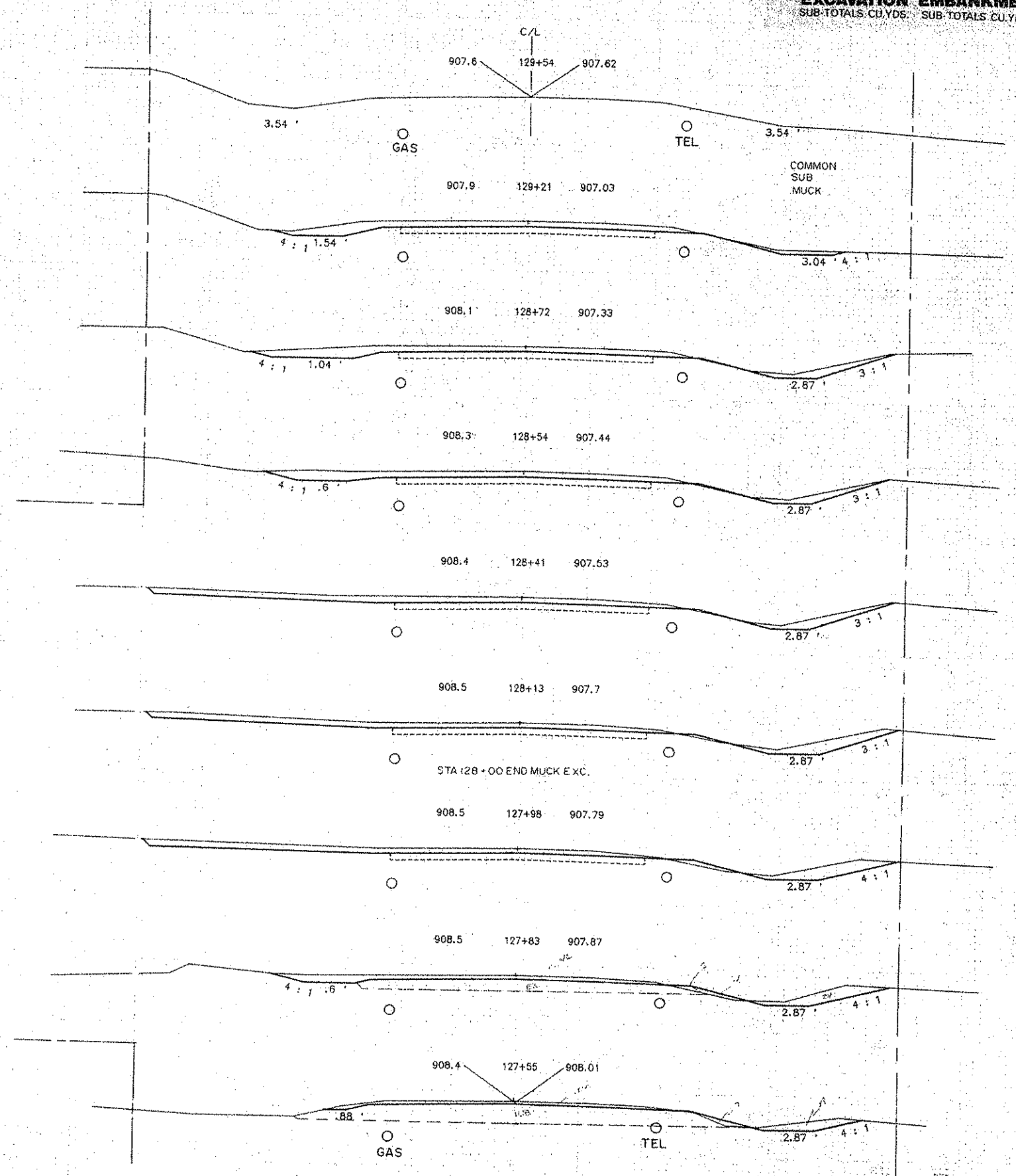
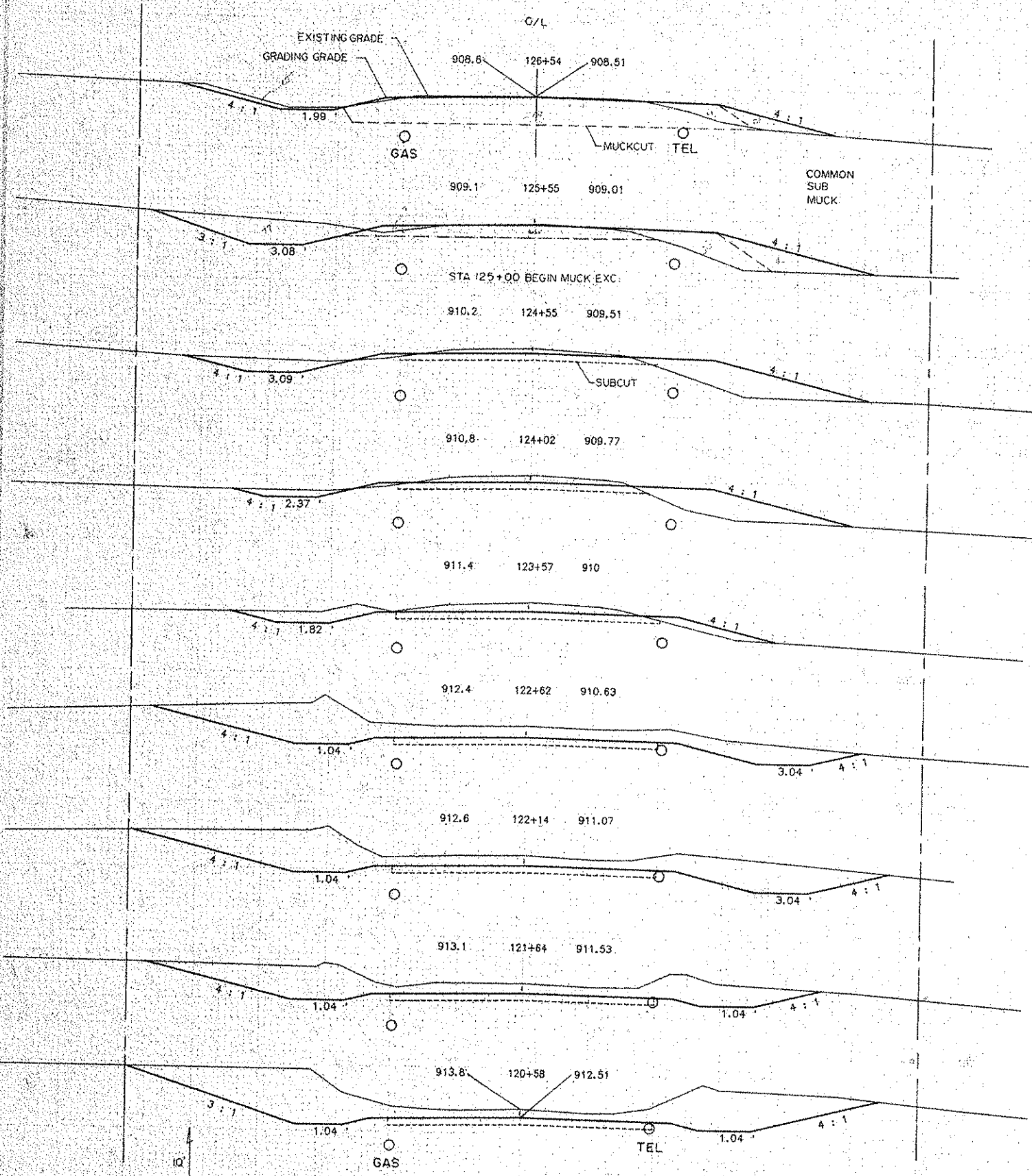

NOTE:
 UTILITY ELEVATIONS ASSUMED
 NOT ACTUAL

CROSS-SECTIONS
 STA. 120+58 TO STA 129+54

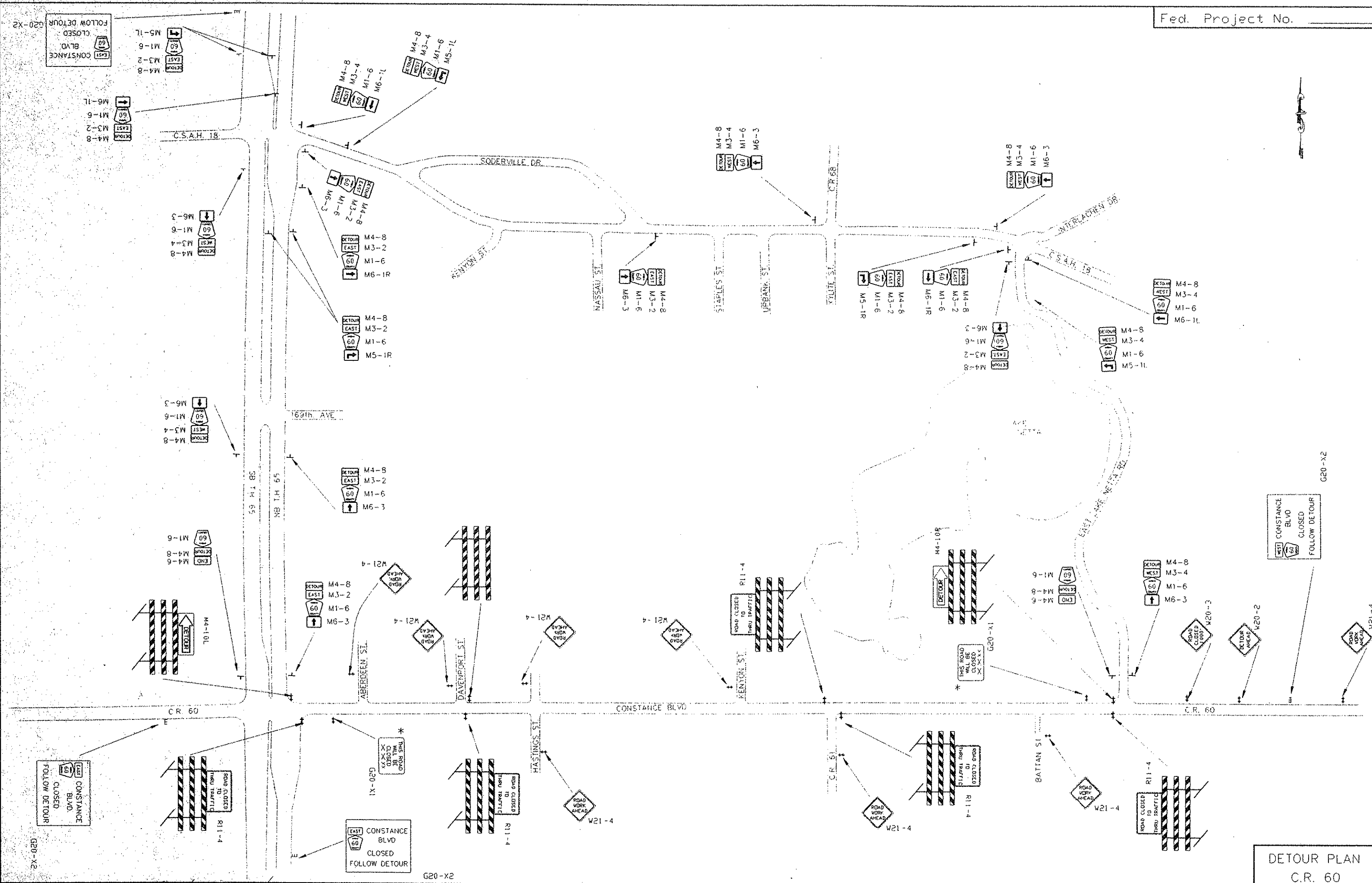

REVISIONS	DATE	BY

DETOUR PLAN
C.R. 60

M. U. T. C. D. CODE	SIZE	INSERT	QUANTITY	M. U. T. C. D. CODE	SIZE	INSERT	QUANTITY
W20-2	48' x 48'		• 1	G20-X2MOD	96' x 72'		• 3
W20-3	48' x 48'		• 1	G20-X2MOD	96' x 72'		• 1
W21-4	48' x 48'		• 8	M4-8	24' x 12'		• 3
R11-4	60' x 30'		• 5	M3-2	21' x 12'		• 2
TYPE III	8 FOOT			M1-6	24' x 24'		• 5
M4-10R	48' x 18'		• 1		21' x 15'		• 2
TYPE III	8 FOOT						• 1
M4-10L	48' x 18'		• 1	M4-8	24' x 12'		• 2
TYPE III	8 FOOT			M3-4	21' x 12'		• 2
TYPE III	8 FOOT		• 1	M1-6	24' x 24'		• 5
G20-X1	60' x 48'		• 2		21' x 15'		
				M4-6	24' x 12'		
				M4-8	24' x 12'		• 2
				M1-6	24' x 24'		

* SIGNS TO BE INSTALLED A MINIMUM OF SEVEN DAYS PRIOR TO ACTUAL CLOSING DATE OF ROAD CLOSURE AND IMPLEMENTATION OF DETOUR SIGNING SIGNS TO BE REMOVED AT TIME OF COMPLETED DETOUR INSTALLATION.

- NOTES:
- 1) ALL BARRICADES SHALL BE PROPERLY WEIGHTED WITH SANDBAGS.
 - 2) ALL BARRICADES SHALL HAVE REFLECTIVE MATERIAL ON BOTH SIDES
 - 3) ALL BARRICADE MARKINGS SHALL BE SLANTED IN ACCORDANCE WITH THE MINNESOTA MANUAL OF UNIFORM TRAFFIC CONTROL DEVICES.
 - 4) ALL TRAFFIC CONTROL DEVICES SHALL CONFORM TO THE MOST RECENT EDITION OF THE MINNESOTA MANUAL ON UNIFORM TRAFFIC CONTROL DEVICES, INCLUDING THE FIELD MANUAL DATED APRIL 1995.
 - 5) ADDITIONS OR CHANGES TO THIS PLAN MAY BE MADE AS DETERMINED BY THE ENGINEER.

REVISION	DATE	BY

CERTIFIED BY Angela M. ... P. E. REG NO. 21235 April 30 19 96

DETOUR PLAN
C.R. 60