

PLAN SYMBOLS

- COUNTY LINE.....
- TOWNSHIP OR RANGE LINE.....
- SECTION LINE.....
- QUARTER LINE.....
- SIXTEENTH LINE.....
- RIGHT OF WAY LINE.....
- SLOPE EASEMENT.....
- PRESENT RIGHT OF WAY.....
- PROPERTY LINE.....
- CORPORATE OR CITY LIMITS.....
- RETAINING WALL.....
- RAILROAD.....
- RAILROAD RIGHT OF WAY.....
- RIVER OR CREEK.....
- DRAINAGE DITCH.....
- CULVERT.....
- DROP INLET.....
- RAILROAD GARD.....
- BARBED WIRE FENCE.....
- WOVEN WIRE FENCE.....
- CHAIN LINK FENCE.....
- WOOD FENCE.....
- STONE WALL OR FENCE.....
- HEDGE.....

- LOWLAND.....
- TIMBER.....
- ORCHARD.....
- BRUSH.....
- NURSERY.....

- CATTLE GARD.....
- OVERPASS (Highway Over).....
- UNDERPASS (Highway Under).....
- BRIDGE.....

- BUILDING (One Story Frame).....
- F-FRAME C-CONCRETE.....
- S-STONE T-TILE.....
- B-BRICK ST-STUCCO.....

- RAILROAD CROSSING BELL.....
- RAILROAD CROSSING GATE.....
- MANHOLE.....
- CATCH BASIN.....
- FIRE HYDRANT.....
- CAST IRON MONUMENT.....
- IRON PIN.....
- GRAVEL PIT.....
- SAND PIT.....
- BORROW PIT.....
- ROCK QUARRY.....
- GEOTECHNICAL BORINGS.....

UTILITY SYMBOLS

- POWER POLE LINE.....
- TELEPHONE OR TELEGRAPH POLE LINE.....
- JOINT TELEPHONE & POWER ON POWER POLES.....
- JOINT TELEPHONE & POWER ON TELEPHONE POLES.....
- ANCHOR.....
- STEEL TOWER.....
- STREET LIGHT.....
- PEDESTAL (Cable Terminal).....
- GAS MAIN.....
- WATERMAIN.....
- TELEPHONE CABLE IN CONDUIT.....
- ELECTRIC CABLE IN CONDUIT.....
- TELEPHONE MANHOLE.....
- ELECTRIC MANHOLE.....
- BURIED TELEPHONE CABLE.....
- BURIED ELECTRIC CABLE.....
- AERIAL TELEPHONE CABLE.....
- SEWER (Sanitary or Storm).....
- SEWER MANHOLE.....

SCALES

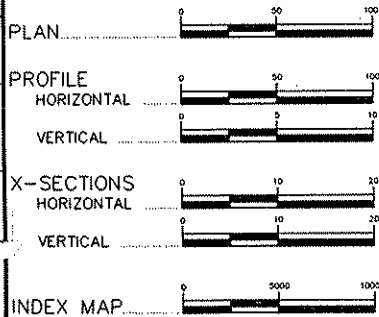

REVISIONS	BY	DATE

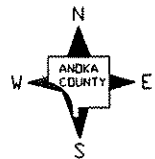

MINNESOTA DEPARTMENT OF TRANSPORTATION

ANOKA COUNTY

CONSTRUCTION PLAN FOR GRADING, AGGREGATE BASE AND BITUMINOUS SURFACING.

LOCATED ON CR 7 BETWEEN CSAH 22 (VIKING BLVD) AND CSAH 24 (227TH AVE.) (GEOGRAPHIC DESCRIPTION)

FROM A POINT 15.610' N. & 72.094' E. OF THE S. 1/4 COR. OF SEC.19,T.33N., R.24W. TO A POINT 1389.304' N. & 1088.624' E. OF OF W.1/4 COR. OF SEC.5,T.33N.,R.24W. (LEGAL DESCRIPTION)

COUNTY PROJ. NO. 94-03-07

GROSS LENGTH..... 21,183.31 FEET 4.012 MILES
 BRIDGES-LENGTH..... FEET MILES
 EXCEPTIONS-LENGTH..... FEET MILES
 NET LENGTH..... 21,183.31 FEET 4.012 MILES

END C.P. 94-03-07
 STA. 711+33

CITIES OF ST. FRANCIS
 OAK GROVE
 BURNS

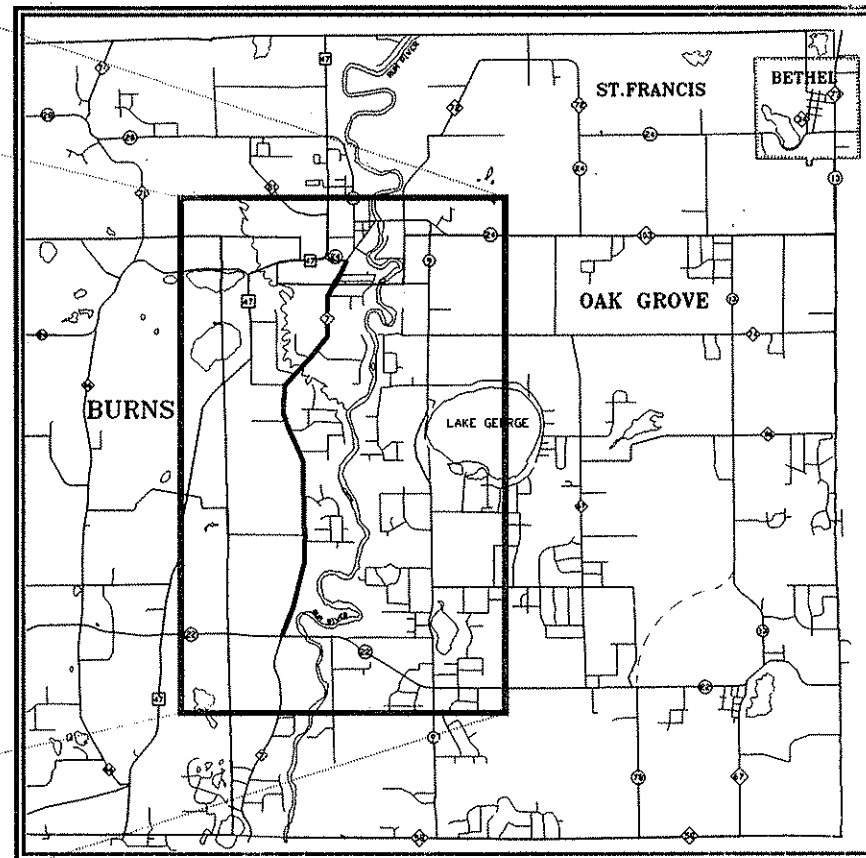
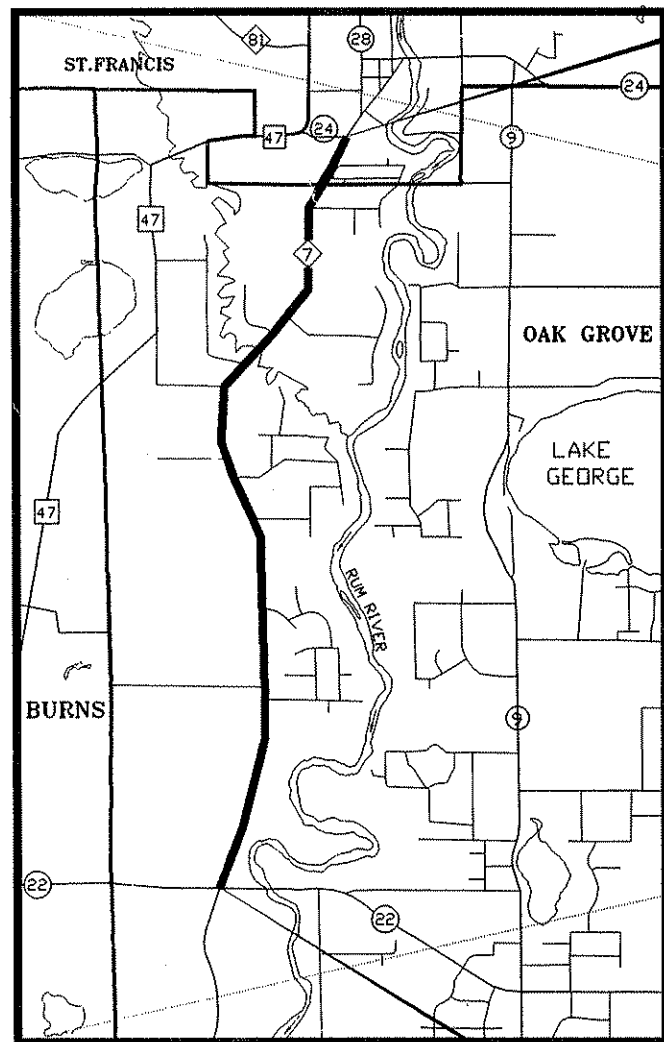

INDEX MAP
 1"=5000'

VICINITY MAP
 1"=2500'

BEGIN. C.P. 94-03-07
 499+50

MINN. PROJ. NO. _____
 MINN. PROJ. NO. _____ LOCAL FUNDS _____
GOVERNING SPECIFICATIONS
 THE 1988 EDITION OF THE MINNESOTA DEPARTMENT OF TRANSPORTATION "STANDARD SPECIFICATIONS FOR CONSTRUCTION" AS AMENDED BY THE MAY 2, 1994 SUPPLEMENTAL SPECIFICATIONS SHALL GOVERN.
 ALL TRAFFIC CONTROL DEVICES SHALL CONFORM TO THE MMUTCD, INCLUDING "FIELD MANUAL FOR TEMPORARY TRAFFIC CONTROL ZONE LAYOUTS APRIL 1995."

INDEX

SHEET NO.	DESCRIPTION
1	TITLE SHEET
2	STATEMENT OF ESTIMATED QUANTITIES
3-7	TABULATION CHARTS
8	EARTHWORK SUMMARY
9-10	EROSION CONTROL DETAILS
11-12	TYPICAL SECTIONS
13-20	EXISTING CONDITIONS AND REMOVAL PLAN
21-23	SUPERELEVATION CHARTS
24-38	PLAN AND PROFILE
39-65	CROSS-SECTION
66-67	DETOUR PLAN

THIS PLAN CONTAINS 67 SHEETS

DESIGN DESIGNATION

EN1820	691.485
R VALUE	60
ADT (1997)=	3,489
Proj. ADT (2017)=	5,931
Proj. HCADT (2017)=	445
Soil Factor	N/A
10 TON DESIGN	
Shoulder Width	8 FT.

Functional Classification COLLECTOR
 No. of Traffic Lanes 2 No. of Parking Lanes 0
 Design Speed:

55 MPH	STA. 499+50 TO STA. 576+67
50 MPH	STA. 576+67 TO STA. 688+05
45 MPH	STA. 685+05 TO STA. 711+33

Based on Stopping Sight Distance
 Height of eye 3.5' Height of object 0.5'
 Design Speed not achieved at:
 STA. TO STA. MPH.
 STA. TO STA. MPH.
 STA. TO STA. MPH.

I HEREBY CERTIFY THAT THIS PLAN WAS PREPARED BY ME OR UNDER MY DIRECT SUPERVISION AND THAT I AM A DULY REGISTERED PROFESSIONAL ENGINEER UNDER THE LAWS OF THE STATE OF MINNESOTA.

DATE 2/21/97 REG. NO. 20235 ENGR. *Randy W. Joch* ASSISTANT COUNTY ENGINEER
 DESIGN SQUAD K. JOHNSON AND M. NAJ

Recommended for Approval	RIGHT-OF-WAY SECTION	19
Recommended for Approval	TRAFFIC SECTION	19
Recommended for Approval	CONSTRUCTION ENGINEER	19
Approved	ANOKA COUNTY ENGINEER	19
Approved	CITY OF OAK GROVE ENGINEER	19
Approved	CITY OF ST. FRANCIS ENGINEER	19

COUNTY PROJ. NO. 94-03-07
 STATE PROJ. NO. _____ SHEET NO. 1 OF 67 SHEETS

STATEMENT OF ESTIMATED QUANTITIES

CHART NO.	ITEM NO.	ITEM	UNIT	ANOKA COUNTY	
				C. P. 94-03-07	
				ESTIMATED	FINAL
	0013.601	CELLULAR MOBILE TELEPHONE	LUMP SUM	1	
	0015.601	COMPUTER EQUIPMENT	LUMP SUM	1	
	2021.501	MOBILIZATION	LUMP SUM	1	
	2031.501	FIELD OFFICE TYPE D	EACH	1	
	A 2101.501	CLEARING	ACRE	11.05	
	A 2101.502	CLEARING	TREE	214	
	A 2101.506	GRUBBING	ACRE	11.05	
	A 2101.507	GRUBBING	TREE	188	
①	H 2104.501	REMOVE FENCE	LIN FT	1413	
②	O 2104.501	REMOVE CULVERT PIPE	LIN FT	496	
③	D 2104.505	REMOVE BITUMINOUS PAVEMENT	SQ YD	51411	
④	K 2104.505	REMOVE CONCRETE PAVEMENT	SQ YD	83	
⑤	F 2104.505	REMOVE GROUTED RIPRAP	SQ YD	20	
⑥	B 2104.511	SAWING CONCRETE PAVEMENT	LIN FT	23	
⑦	E 2104.513	SAWING BITUMINOUS PAVEMENT	LIN FT	600	
⑧	H 2104.521	SALVAGE FENCE	LIN FT	8421	
⑨	I 2104.521	SALVAGE TWISTED END TREATMENT	EACH	4	
⑩	2104.523	SALVAGE SIGN TYPE C	EACH	133	
⑪	2104.523	SALVAGE SIGN TYPE SPECIAL	EACH	14	
⑫	0104.602	SALVAGE STONE FOUNDATION	* CU YD	100	
	U 2105.501	COMMON EXCAVATION	* CU YD	115144 (P)	
	U 2105.507	SUBGRADE EXCAVATION	CU YD	5979	
	U 2105.525	TOPSOIL BORROW (LV)	CU YD	4312	
⑬	2123.509	DOZER	HOUR	80	
⑭	2130.501	WATER	M-GALLON	350	
⑮	V,K 2211.503	AGGREGATE BASE (CV) CLASS-5A	CU YD	16379 (P)	
⑯	C 2232.501	MILL BITUMINOUS SURFACE	SQ YD	1882	
⑰	K 0331.601	2" THICK BITUMINOUS WEARING COURSE	SQ YD	2082	
⑱	0331.601	SAWED/SEALED JOINT	LIN FT	15845	
⑲	V 2340.508	TYPE 41 WEARING COURSE MIXTURE	TON	8017	
⑳	V 2340.510	TYPE 31 BINDER COURSE MIXTURE	TON	6150	
㉑	V 2340.514	TYPE 31 BASE COURSE MIXTURE	TON	8145	
	V 2357.502	BITUMINOUS MATERIAL FOR TACK COAT	GALLON	6134	
	0412.602	MAIL BOX SUPPORT	EACH	58	
	O,R 2501.511	15" CS PIPE CULVERT	LIN FT	1646	
	O 2501.511	18" CS PIPE CULVERT	LIN FT	1494	
	O 2501.515	24" RC PIPE APRON	EACH	12	
	R 2501.515	18" RC SAFETY APRON & GRATE, DES 3128F	EACH	2	
	R 2501.515	36" RC PIPE APRON	EACH	2	
	O 2501.561	24" RC PIPE CULVERT, DES 3006	LIN FT	304	
	O 2501.567	15" CS SAFETY APRON & GRATE, DES 3128F	EACH	86	
	O,R 2501.567	18" CS SAFETY APRON & GRATE, DES 3128F	EACH	28	
	R 2503.501	18" RC PIPE SEWER DESIGN 3006	LIN FT	628	
	R 2503.501	36" RC PIPE SEWER DESIGN 3006	LIN FT	460	
	O 0504.602	ADJUST VALVE BOX- WATER	EACH	4	
	P 0504.602	RELOCATE HYDRANT AND VALVE	EACH	1	
	R 2506.501	CONSTRUCTION DRAINAGE STRUCTURE DESIGN 60-4020	LIN FT	9.2	
	R 2506.501	CONSTRUCTION DRAINAGE STRUCTURE DESIGN H	LIN FT	11.7	
	R 2506.501	CONSTRUCTION DRAINAGE STRUCTURE DESIGN SPECIAL 1	LIN FT	3.8	
	R 2506.501	CONSTRUCTION DRAINAGE STRUCTURE DESIGN SPECIAL 2	LIN FT	3.6	
	T 2506.516	CASTING ASSEMBLY	EACH	6	
	S 0506.602	ADJUST FRAME AND RING CASTING (SANITARY)	EACH	4	

BASIS OF PLANNED QUANTITIES

2340	TYPE 31 PLANT MIXED WEARING COURSE AND BINDER COURSE BITUMINOUS MIXTURE 110 LBS./SQ. YD. PER 1" THICKNESS
2340	TYPE 31 PLANT MIXED BASE BITUMINOUS MIXTURE 110 LBS./SQ. YD. PER 1" THICKNESS
2357	BITUMINOUS MATERIAL FOR TACK 0.05 GALLONS PER SQ. YD. PER LIFT APPLIED
2575	MULCH MATERIAL TYPE 1, 2 TONS PER ACRE
2575	COMMERCIAL FERTILIZER, ANALYSIS 10-10-10 (OR EQUIVALENT) 500 LBS./ACRE ON ALL SEED AREAS
2575	ROADSIDE SEEDING BASED ON HORIZONTAL MEASUREMENT +10% SEED MIXTURE NO. 900, 45 LBS. PER ACRE

STATEMENT OF ESTIMATED QUANTITIES

CHART NO.	ITEM NO.	ITEM	UNIT	ANOKA COUNTY	
				C. P. 94-03-07	
				ESTIMATED	FINAL
	O,R 2511.507	GROUTED RIPRAP	CU YD	5.8	
	K 2531.507	6" CONCRETE DRIVEWAY PAVEMENT	SQ YD	70	
⑳	J 2535.501	BITUMINOUS CURB	LIN FT	3453	
	M 0554.602	ECCENTRIC LOADER BCT	EACH	4	
㉑	H 0557.603	INSTALL FENCE	LIN FT	7879	
	H 0557.603	TEMPORARY FENCING	LIN FT	546	
	0563.601	DETOUR SIGNING	LUMP SUM	1	
㉒	0564.602	INSTALL SIGN TYPE SPECIAL	EACH	14	
㉓	2573.501	BALE CHECK	EACH	320	
㉔	G 2573.503	SILT FENCE, PREASSEMBLED	LIN FT	2238	
㉕	L 2573.508	BITUMINOUS LINED FLUME	SQ YD	195	
	N 2575.501	SEEDING	ACRE	35.3 (P)	
	N 2575.503	SEED, MIXTURE 900	POUND	1498	
	N 2575.505	SODDING, TYPE LAWN AND BOULEVARD	SQ YD	26337	
	N 2575.511	MULCH MATERIAL TYPE-1	TON	70.6	
	2575.519	DISK ANCHORING	ACRE	35.3 (P)	
㉖	N,O 2575.524	TURF ESTABLISHMENT BLANKET, TYPE STRAW	SQ YD	8776	
	N 2575.531	COMMERCIAL FERTILIZER ANALYSIS 10-10-10	POUND	17630	
	2580.501	TEMPORARY LANE MARKING	RD STA	636	

STANDARD PLATES

THESE STANDARD PLATES AS APPROVED BY THE FHWA SHALL APPLY.

PLATE NO.	DESCRIPTION
3000 L	REINFORCED CONCRETE PIPE
3006 G	GASKET JOINT FOR R. C. PIPE
3040 F	CORRUGATED METAL PIPE CULVERT
3100 G	CONCRETE APRON FOR REINFORCED CONCRETE PIPE
3128 F	SAFETY APRON
3133 B	RIPPRAP AT RCP OUTLETS
3145 E	CONCRETE PIPE TIES
3221 C	CORRUGATED STEEL PIPE COUPLING BAND
4010 H	CONCRETE SHORT CONE AND ADJUSTING RING
4101 C	RING CASTING FOR MANHOLE OR CATCH BASIN
4110 F	COVER CASTING FOR MANHOLE
4180 H	MANHOLE OR CATCH BASIN STEP
4006 L	MANHOLE OR CATCH BASIN
4220 G	MANHOLE OR CATCH BASIN COVER
8000 L	STANDARD BARRICADES
8307 P	STEEL PLATE BEAM GUARDRAIL
8329 F	ECCENTRIC LOADER BREAKAWAY CABLE TERMINAL (ELT)
9132 D	TURF ESTABLISHMENT AREAS (AT PIPE CULVERT ENDS)
9322 J	CHAIN LINK FENCE

SEE TRAFFIC SIGNAL PLAN SHEETS FOR ADDITIONAL STANDARD PLATES

INDEX OF TABULATION CHARTS

CHART	SHEET No.	DESCRIPTION
A	3-4	CLEARING AND GRUBBING
B	4	SAWING CONCRETE PAVEMENT
C	4	MILL BITUMINOUS SURFACE
D	4	BITUMINOUS REMOVAL
E	4	SAWING BITUMINOUS PAVEMENT
F	4	CONCRETE RIPRAP REMOVAL
G	4	SILT FENCE
H	4	FENCE CONSTRUCTION AND REMOVALS
I	4	SALVAGE TWISTED END TREATMENT
J	4	BITUMINOUS CURB CONSTRUCTION
K	5	ENTRANCES REMOVAL AND CONSTRUCTION
L	5	BITUMINOUS FLUME CONSTRUCTION
M	5	GUARDRAIL CONSTRUCTION
N	5	TURF ESTABLISHMENT
O	6	CULVERT TABULATION
P	6	RELOCATE HYDRANT
Q	6	ADJUST VALVE BOX-WATER
R	7	STORM SEWER TABULATION
S	7	SANITARY MANHOLES TABULATION
T	7	DRAINAGE CASTING SCHEDULE
U	8	EARTHWORK SUMMARY
V	8	BASE AND BITUMINOUS QUANTITIES CHART
W	11	RIGHT TURN LANE AND BYPASS LOCATION
X	12	BERM CONSTRUCTION LOCATIONS

NOTES

- ① INCLUDES ALL TYPES AND SIZES.
- ② INCLUDES ALL BITUMINOUS PAVEMENTS (REGARDLESS OF DEPTH AND WIDTH).
- ③ MUNICIPAL STREET SIGNS.
- ④ FOR DUST CONTROL AS DIRECTED BY THE ENGINEER.
- ⑤ INCLUDES QUANTITY FOR AGGREGATE APPROACHES AND ENTRANCES.
- ⑥ INCLUDES QUANTITY FOR ADDITIONAL 1/4" TO DESIGN PAVEMENT THICKNESS.
- ⑦ FOR DRIVEWAY CONSTRUCTION, SEE CHART K.
- ⑧ SEE SHEET 11 AND SPECIAL PROVISIONS FOR ALTERNATE CONCRETE CURB AND GUTTER.
- ⑨ FOR EROSION CONTROL AS SHOWN IN THE PLANS OR AS DIRECTED BY THE ENGINEER.
- ⑩ JOINTS TO BE PLACED AT 40 FT SPACING ACROSS LANES OF TRAFFIC AND EXTEND 1 FT.
- ⑪ OLD BARN FOUNDATION ON PARCEL 5.
- ⑫ FOR USE AT CULVERT ENDS AND AS DIRECTED BY THE ENGINEER. SEE STD. PLATE 9102 D.
- ⑬ FOR SPREADING EXCESS MATERIAL FOR THE NEW ANOKA COUNTY FACILITY LOCATED WEST OF STA. 694+37 TO 701+52.
- ⑭ SALVAGE TO ANOKA COUNTY HIGHWAY MAINTENANCE.

REVISIONS BY DATE BY
 * 3-4-97 DWF

CLEARING AND GRUBBING (A)

Table with 6 columns: STATION - STATION, LOCATION, CLEARING TREE, CLEARING ACRE, GRUBBING TREE, GRUBBING ACRE. Rows include station ranges like 499+43 to 554+05.

CLEARING AND GRUBBING (A)

Table with 6 columns: STATION - STATION, LOCATION, CLEARING TREE, CLEARING ACRE, GRUBBING TREE, GRUBBING ACRE. Rows include station ranges like 554+07 to 616+00.

CLEARING AND GRUBBING (A)

Table with 6 columns: STATION - STATION, LOCATION, CLEARING TREE, CLEARING ACRE, GRUBBING TREE, GRUBBING ACRE. Rows include station ranges like 616+06 to 652+51.

CLEARING AND GRUBBING (A)

Table with 6 columns: STATION - STATION, LOCATION, CLEARING TREE, CLEARING ACRE, GRUBBING TREE, GRUBBING ACRE. Rows include station ranges like 652+52 to 682+95.

FILE NAME: \940307.DWG\07TAB-CH.DWG M.N. 02-18-97

REVISIONS table with columns: NO., DATE, BY.

CERTIFIED BY Randall M. ...

P. E. REG NO. 20235 2/21 19 97

S. P. _____ S. A. P. _____ C. P. 94-03-07 Sheet No. 3 of 67 Sheets

CULVERT TABULATION

(D)

STATION	LOC	INPLACE	REMARKS	FURNISH AND INSTALL						FIBER BLANKET SQ. YD.	RIPRAP OUTLETS CU. YD.			
				REMOVE CULV. PIPE		15' CMP		18' CMP				24' RCP		
				LIN. FT.	APRON	LIN. FT.	APRON	LIN. FT.	APRON			LIN. FT.	APRON	
501+43	LT.	15" X 33' CMP	ENTRANCE - NO CULV. REQ'D.	33										
503+42	RT.	15" X 32' CMP	ENTRANCE - NO CULV. REQ'D.	32										
508+21	LT.		SEE STORM SEWER CHART											
507+84	RT.	15" X 32' CMP	ENTRANCE	32		38	2							
513+50	RT.		ENTRANCE			32	2							
514+44	C/L	15" X 36' CMP	C/L PIPE CROSSING	36						50	2	28		
515+90	LT.		ENTRANCE			42	2							
520+08	LT.	15" X 37' CMP	OUTLET FROM POND										2.2	
521+71	RT.		ENTRANCE	27		40	2							
521+84	LT.	18" X 54' CSP	200 TH. LANE	54				48	2			101		
533+68	RT.		ENTRANCE - NO CULV. REQ'D.									42		
535+80	LT.		ENTRANCE			38	2							
536+98	LT.		ENTRANCE			46	2							
542+36	LT.		ENTRANCE			36	2							
542+43	RT.		ENTRANCE			44	2							
543+22	LT.		ENTRANCE			50	2							
545+02	RT.		ENTRANCE			52	2							
550+95	RT.		204 LN. N.W.					56	2			101		
553+88	LT.		ENTRANCE - NO CULV. REQ'D.									42		
558+40	RT.		ENTRANCE			38	2							
562+14	C/L		C/L PIPE CROSSING							48	2	28		
563+01	RT.		ENTRANCE - NO CULV. REQ'D.			36	2							
564+12	RT.		ENTRANCE - NO CULV. REQ'D.			38	2							
565+59	RT.		ENTRANCE - NO CULV. REQ'D.			38	2							
566+47	RT.		ENTRANCE - NO CULV. REQ'D.			38	2							
568+50	RT.	15" X 30' CMP	ENTRANCE - NO CULV. REQ'D.	30		40	2							
568+59	LT.		ENTRANCE			38	2							
569+30	LT.		ENTRANCE			34	2							
572+08	LT.		ENTRANCE			38	2							
572+56	LT.		ENTRANCE			36	2							
574+38	RT.		208 T.H. AVE. N.W.					56	2			101		
581+81	LT.		SEE STORM SEWER CHART											
583+89	C/L	15" X 40' CMP	REMOVAL AT 584+95	40						50	2	28		
587+05	LT.		ENTRANCE			40	2					85		
587+05	RT.		ENTRANCE			40	2					127		
590+84	LT.		ENTRANCE - NO CULV. REQ'D.											
597+79	RT.		211 LN.N.W.-NO CULV. REQ'D.											
601+07	RT.		ENTRANCE - NO CULV. REQ'D.											
601+29	LT.		ENTRANCE			28	2							
604+56	LT.		SEE STORM SEWER CHART											
606+50	LT.	15" X 31' CMP	SEE STORM SEWER CHART	31										
609+71	RT.		SUNSHINE DR. N.W.					52	2			172		
615+12	LT.	15" X 46' CMP	214 T.H. AVE. N.W.	46				46	2			192		
615+12	RT.		ENTRANCE - NO CULV. REQ'D.											
616+94	RT.		ENTRANCE - NO CULV. REQ'D.											
617+24	LT.		ENTRANCE - NO CULV. REQ'D.											
619+00	LT.		ENTRANCE - NEW			22	2							
620+01	LT.	15" X 30' CMP	ENTRANCE	30		40	2							
621+45	LT.		ENTRANCE - REMOVE											
623+69	RT.		ENTRANCE			36	2							
623+94	LT.		ENTRANCE			50	2							
627+49	RT.		ENTRANCE			44	2							
628+45	C/L		C/L PIPE CROSSING							52	2	28		
630+66	RT.		ENTRANCE			44	2							
633+00	LT.		ENTRANCE			34	2							
634+78	LT.		217 T.H. - NO CULV. REQ'D.									161		
634+78	RT.		ENTRANCE - NO CULV. REQ'D.											
641+69	LT.		218 T.H. AVE. N.W.					52	2			220		
646+16	RT.		ENTRANCE - NO CULV. REQ'D.											
653+30	LT.		219 T.H. AVE. N.W.					44	2					
653+87	RT.		ENT. - SEE STORM SEWER											
654+95	RT.		ENT. - SEE STORM SEWER											
655+85	LT.		ENTRANCE			42	2							
658+63	RT.		219 T.H. AVE. N.W.									61		
659+20	C/L		C/L PIPE CROSSING							48	2			
660+27	LT.		ENTRANCE			42	2							
665+49	LT.		ENTRANCE			38	2					61		
666+83	RT.		ENTRANCE			40	2							
667+60	LT.		ENTRANCE			28	2					61		
670+90	RT.	15" X 30' CMP	ENTRANCE	30		44	2							
673+56	LT.		ENTRANCE			38	2							
677+06	RT.		ENTRANCE			32	2							
681+43	RT.		ENTRANCE - NO CULV. REQ'D.											
681+74	LT.		ENTRANCE			32	2							
682+48	LT.		ENTRANCE - NO CULV. REQ'D.											
688+18	LT.		ENTRANCE			38	2							
688+10	RT.		224 T.H. AVE. N.W.					60	2			101		
689+40	LT.		ENTRANCE			40	2							
692+08	LT.		ENTRANCE			28	2							
697+55	LT.		NEW ENTRANCE					56	2			110		
697+55	RT.		225 T.H. AVE. N.W.					56	2			110		
705+23	RT.	18" X 48' CMP	227 T.H. AVE. N.W.					66	2			22		
706+52	C/L		C/L PIPE CROSSING	48						56	2	26		
708+64	LT.		ENTRANCE			36	2							
TOTALS				469		1646	86	592	22	304	12	2008	2.2	

RELOCATE HYDRANT (P)

STATION	LOCATION	REMARKS	EACH	PRDP. STA.	PRDP. LOC.
697+77	60.5' RT.	NO WORK REQUIRED			
702+49	34' LT.		1	702+49	58' LT.
TOTAL =			1		

ADJUST VALVE BOX-WATER (Q)

STATION	LOCATION	REMARKS	EACH
697+62	40.7' RT.		1
697+63	32.9' RT.		1
697+66	39.2' RT.		1
709+80.2	39.5' RT.		1
TOTAL =			4

TABULATION CHARTS

CULVERT TABULATION
ADJUST VALVE BOX - WATER
RELOCATE HYDRANT

REVISIONS	BY	DATE

FILE NAME: \940307.DWG\07TAB-CH.DWG M.N. 02-18-97

STORM SEWER TABULATION

STRUCT.	STATION	LOC	REMARKS	MH/CB	DESIGN	PAY HT. LIN. FT.	TOP OF CASTING ELEVATION	OUTLET ELEVATION	RE-CONST. LIN. FT.	FURNISH AND INSTALL			APRONS			DRAINS TO	GRADE IN%	PIPE LOWER ELEVATION	RIP-RAP C. Y.
										CASTING ASSEMBLY	18" CMP LIN. FT.	18" RCP LIN. FT.	36" RCP LIN. FT.	18" CMP	18" RCP				
1	507+57	35.0' LT	APRON INLET		APRON		900.65	900.65							2	-0.5125	900.65		
2	509+12	35.0' LT		MH	H	3.7	904.14	899.85							3	-0.561	898.98		
3	510+70	35.0' LT	APRON OUTLET		APRON			898.98							DITCH	-0.6062			
4	580+32	35.0' LT	APRON INLET		APRON			894.19							5	-0.406	893.80		
5	581+28	35.0' LT		MH	H	3.8	898.18	893.80							6	-0.5052	893.03		
6	583+18	35.0' LT	APRON OUTLET		APRON			893.03							DITCH	-0.145			
7	603+82	35.0' LT	APRON INLET		APRON			901.69							8	-0.4471	900.99		
8	605+38	35.0' LT		MH	H	4.2	905.75	900.99							9	-0.4471	900.30		
9	606+94	35.0' LT	APRON OUTLET		APRON			900.30							DITCH	-0.4471			
10	652+63	39.0' RT	APRON OUTLET		APRON			893.12							10	3.16	893.12	3.6	
11	653+12	21.0' RT		CB	SPECIAL-2	3.6	898.67	894.67							11	3.97	894.67		
12	655+30	21.0' RT		CB	SPECIAL-1	3.8	907.49	903.32							12	2.61	903.32		
13	656+94	39.0' RT	APRON INLET		APRON			912.75							DITCH				
14	695+14	133.0' ± LT	ACHD SHOP SITE - C/L DIT.		APRON		912.00±	901.50±							14	0.31	901.50		
15	697+10	255.0' ± LT	ACHD SHOP SITE - C/L DIT.	MH	60-4020	9.2	912.00±	902.19±							15	0.31	902.19		
16	698+97	388.0' ± LT	ACHD SHOP SITE - C/L DIT.		APRON			902.90±										3.6	
TOTALS=						28.3				6	902	628	460	6	2	2			

H	11.7
SPECIAL-1	3.8
SPECIAL-2	3.6
54-4020	9.2

SANITARY MANHOLES TABULATION

STATION	LOC	OWNERSHIP	INPLACE ELEV.	PROPOSED ELEV.	ADJUST FT.	REMARKS
704+99.8	50.8' RT	ST.FRANCIS	910.58	912.40	+1.82	
709+00.4	49.6' RT	ST.FRANCIS	911.96	910.43	-1.53	
709+01.9	16.4' RT	ST.FRANCIS	912.20	912.17	-0.03	
709+03.2	26.1' LT	ST.FRANCIS	912.32	912.32	0.00	NO ADJUSTMENT REQUIRED
709+48.1	49.5' RT	ST.FRANCIS	911.20	910.51	-0.69	

TYPICAL BOX CATCH BASIN

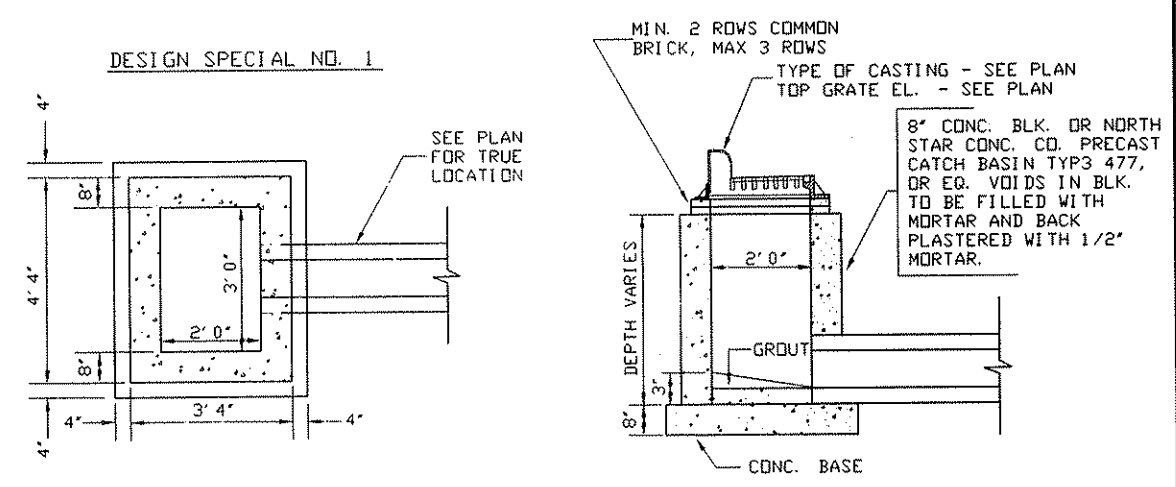

C. B. CASTING DETAIL DESIGN SPECIAL NO. 1

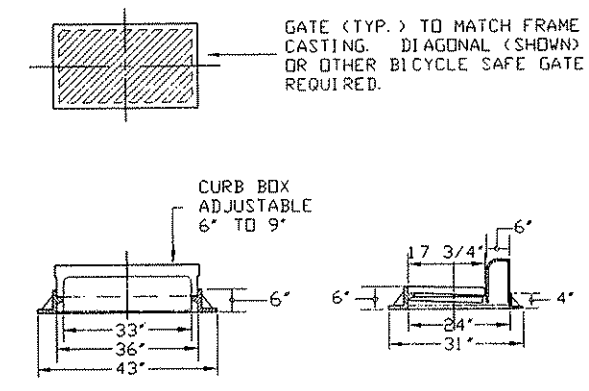

DESIGN SPECIAL NO. 2

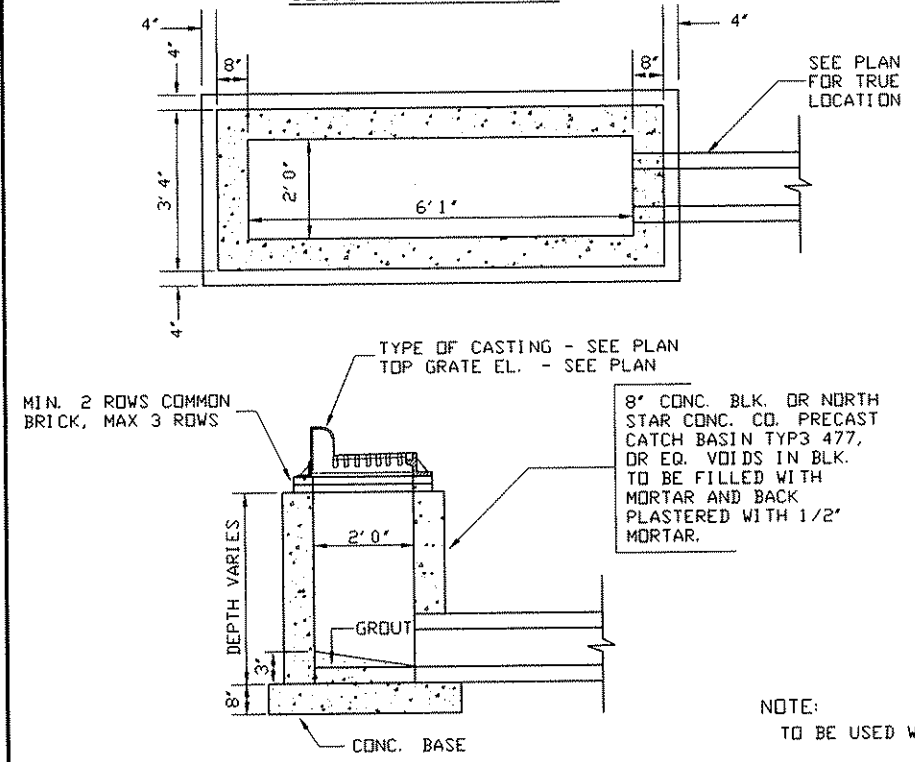

C. B. CASTING DETAIL DESIGN SPECIAL NO. 2

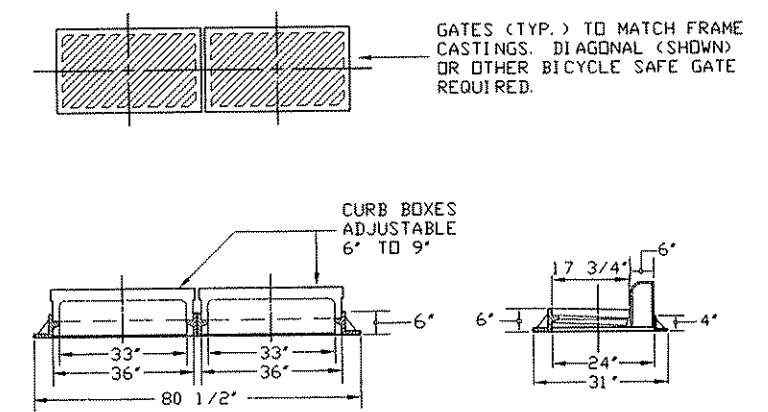

TABULATION CHARTS

STORM SEWER TABULATION
DRAINAGE CASTING SCHEDULE
ADJUST SANITARY MANHOLES
STORM SEWER STRUCTURES

REVISIONS
DATE
BY

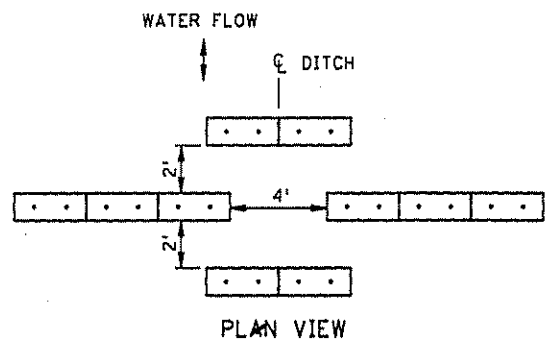

PLAN VIEW

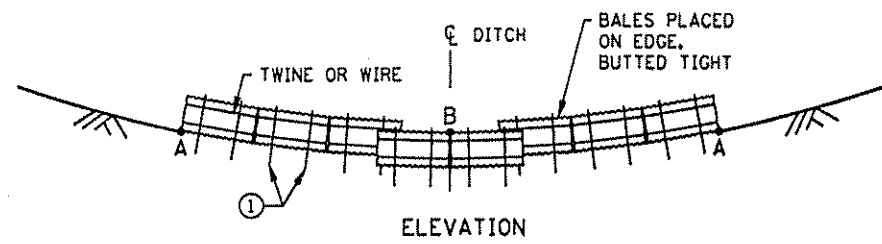

ELEVATION

NOTE:
POINT A MUST BE HIGHER THAN POINT B

BALE DITCH VELOCITY CHECKS
(WILL REQUIRE A MINIMUM OF 10 BALES PER SITE)

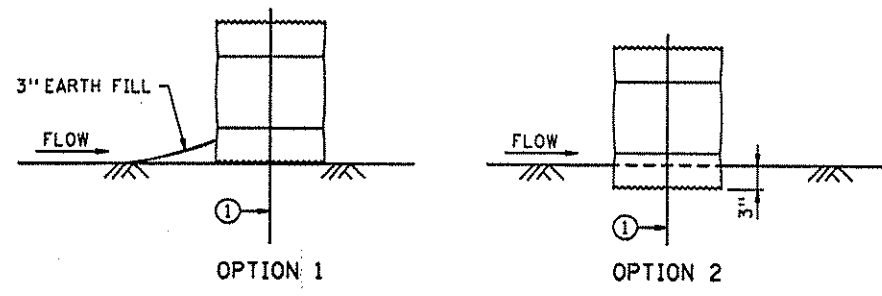

BALE CHECK DETAILS

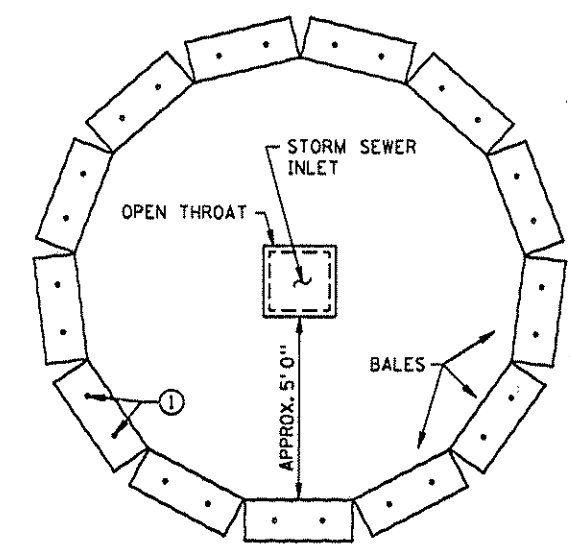

BALE CHECK TO PROTECT STORM SEWER INLETS

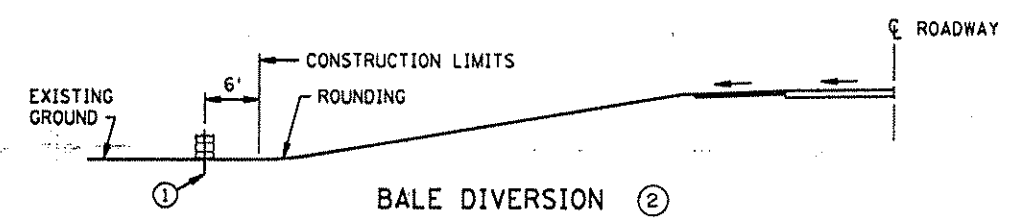

BALE DIVERSION ②

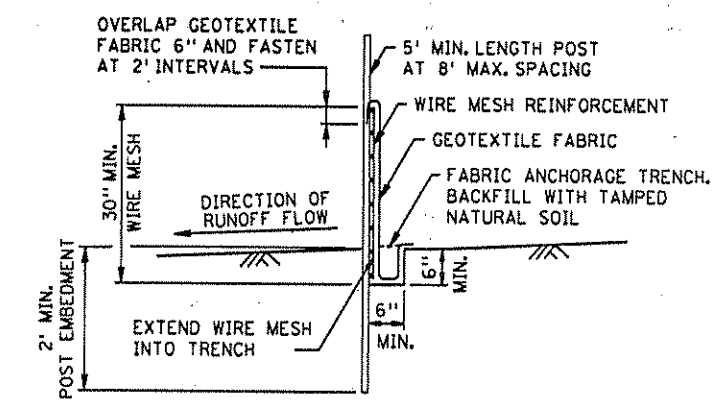

SILT FENCE DETAIL

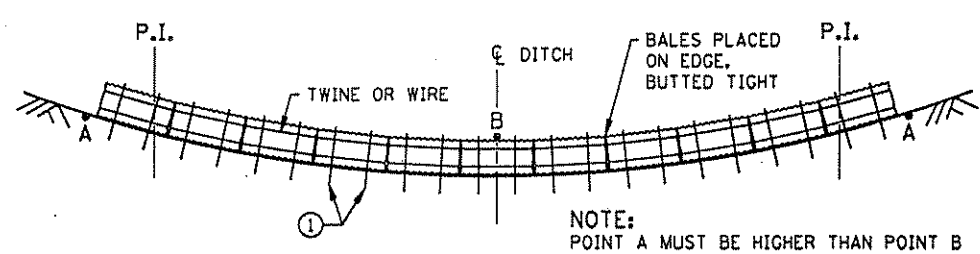

BALE DITCH SEDIMENT CHECK

NOTE:
POINT A MUST BE HIGHER THAN POINT B

RECOMMENDED SPACING BETWEEN BALE DITCH CHECKS	
DITCH GRADE (%)	SPACING (FT.)
2	100
4	75
6	50
8	40
10	25

NOTE:
① TWO 2" X 2" WOOD STAKES OR REINFORCING BARS IN EACH BALE AND EMBEDDED IN THE GROUND 10" MINIMUM.
② SILT FENCE MAY ALSO BE USED AS A DEVIATION DEVICE.

SERVER CAG4511/USFR/STANDARDS FILE NAME S4052H93.SPN

CERTIFIED BY *Douglas M. [Signature]* P.E. REG NO. 20835 2/21 19 97

STANDARD SHEET NO. 5-297.405 (MODIFIED)	TITLE: TEMPORARY EROSION CONTROL
STANDARD APPROVED: AUGUST 2, 1993	
CO. PROJ. NO. <u>94-03-02</u>	SHEET NO. <u>9</u> OF <u>67</u> SHEETS

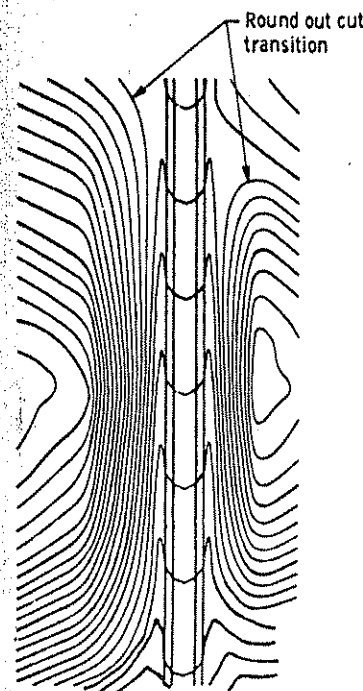

CONTOURING ROAD CUTS

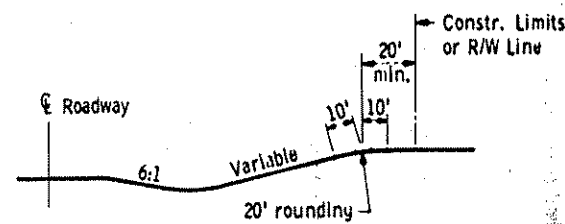

ROUNDING BACK SLOPES

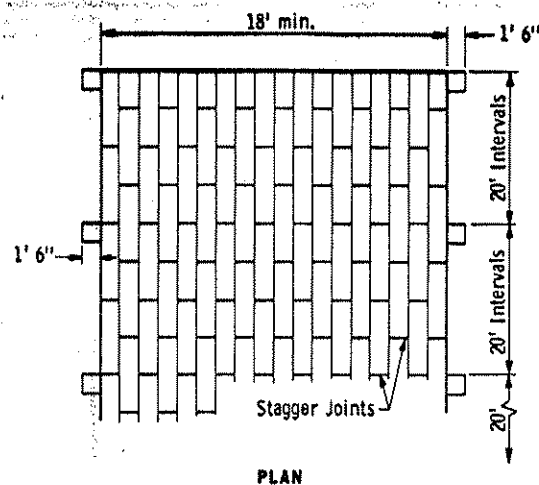

PLAN

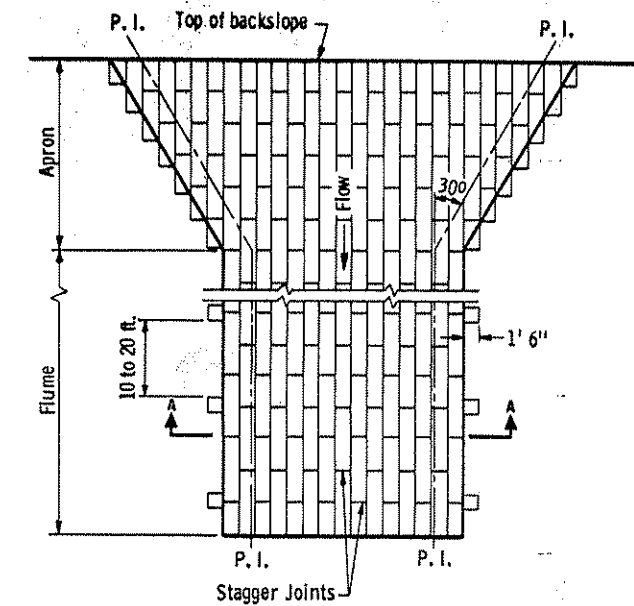

PLAN

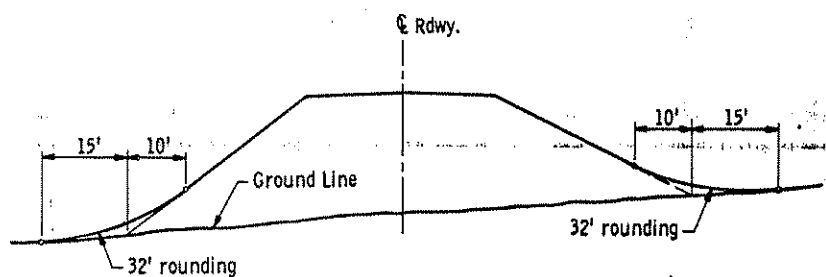

SHAPING FOR DRAINAGE ALONG THE TOE OF FILL SLOPES

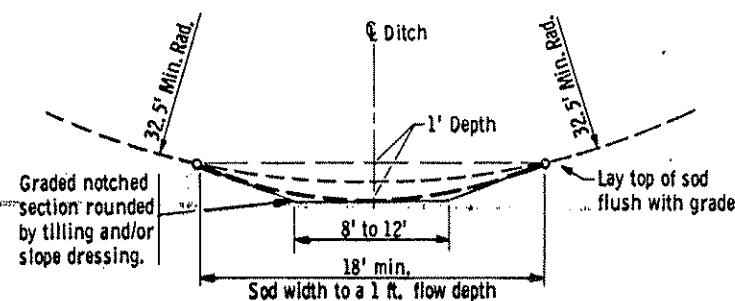

SODDED DITCH CROSS SECTION

Ditches having a minimum radius of 32.5 feet and requiring sod shall be constructed according to the above details. Where ditch radius is less than 32.5 feet, notching is not required. Sod a minimum of 18 feet in width.

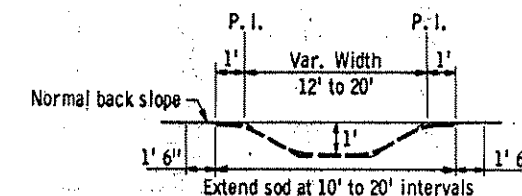

SECTION A-A

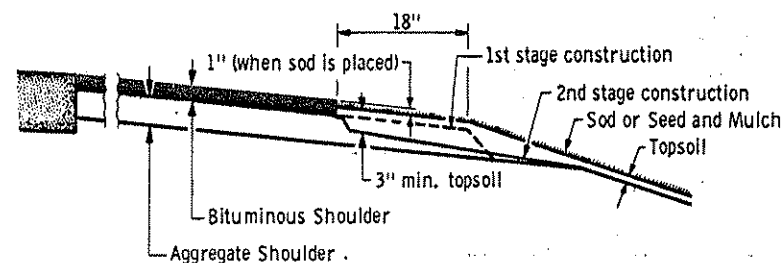

SHAPING AND TOPSOILING INSLOPES

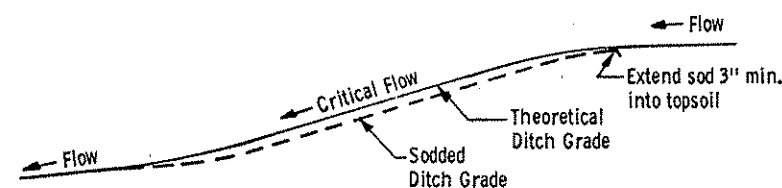

DITCH PROFILE

NOTE: APPLIES TO DITCH GRADES 2.0% OR GREATER.

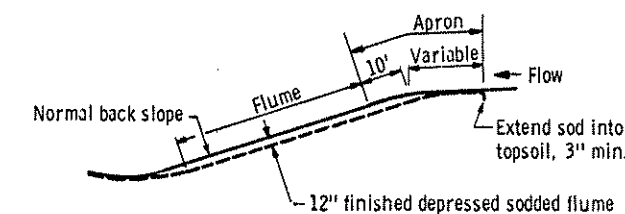

LONGITUDINAL CROSS SECTION

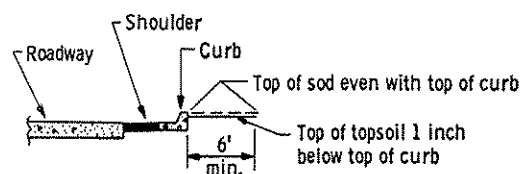

SHAPING ADJACENT TO CURBS WHEN SOD IS PLACED

SODDED DITCH DETAILS

SODDED FLUME DETAILS

APPROVED Dec. 17, 1974
 Leonard & Eitte
 Engineering Standards Engineer
 MATERIALS, RESEARCH AND
 STANDARDS DIVISION

GRADING SECTION

STA. 499+34.69 TO STA. 709+43

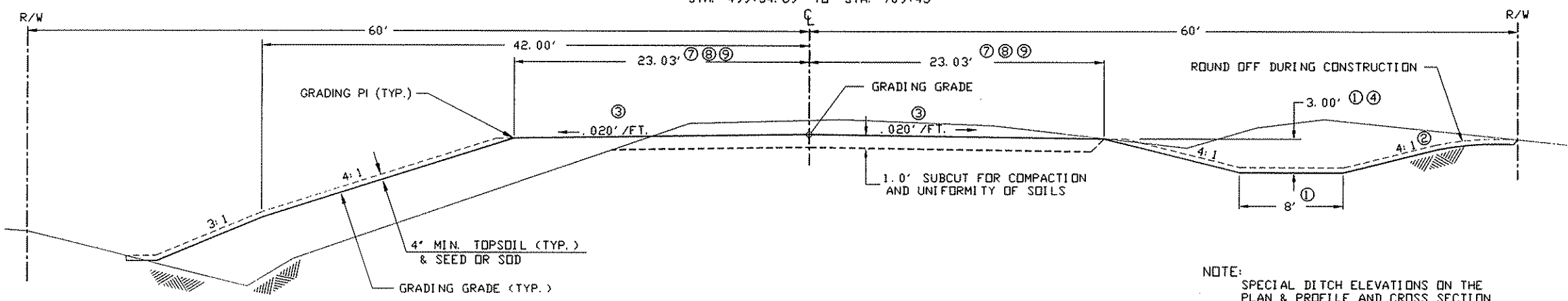

DESIGN F-1
(ALL TRAVEL LANES)

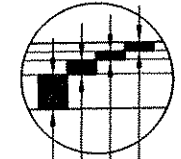

- GE = 14.5"
- 1 1/2" TYPE 41 WEARING COURSE—SPEC. 2340 BITUMINOUS MIXTURE DESIGNATION: 41WEA50055Y
 - 1 1/2" TYPE 31 BINDER COURSE—SPEC. 2340 BITUMINOUS MIXTURE DESIGNATION: 31BB50000Y
 - 2" TYPE 31 BASE COURSE—SPEC. 2340 BITUMINOUS MIXTURE DESIGNATION: 31BB50000Y
 - 4 1/2" AGGREGATE BASE CLASS 5A—SPEC. 2211 TACK COAT—SPEC. 2357, TO BE APPLIED BETWEEN ALL BITUMINOUS LIFTS.

BASE AND BITUMINOUS SECTION

STA. 499+34.69 TO STA. 709+43

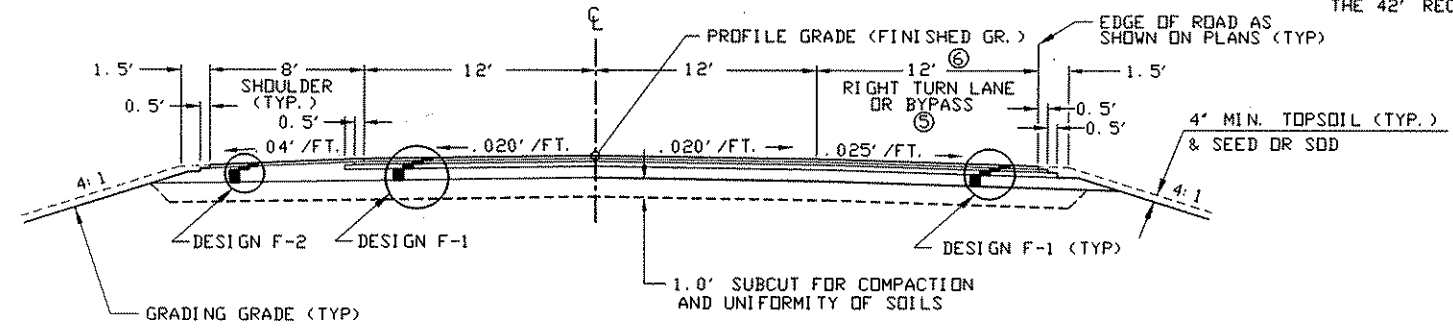

NOTE:
SPECIAL DITCH ELEVATIONS ON THE PLAN & PROFILE AND CROSS SECTION SHEETS ARE FINISHED GRADE ELEVATIONS.
RECOVERY AREA IS 42' FROM CENTERLINE. ALL UTILITY POLES AND UNYIELDING OBJECTS SHALL BE REMOVED AND RELOCATED OUTSIDE THE 42' RECOVERY AREA.

DESIGN F-2
(ALL SHOULDERS)

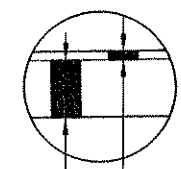

- GE = 10"
- 1 1/2" TYPE 41 WEARING COURSE—SPEC. 2340 BITUMINOUS MIXTURE DESIGNATION: 41WEA50055Y
 - VARIABLE DEPTH AGGREGATE BASE CLASS 5A SPEC. 2211 AVG = 7"

SUBGRADE EXCAVATION

STA. 499+75	TO	STA. 503+50	RT.
STA. 583+25	TO	STA. 586+50	RT.
STA. 605+00	TO	STA. 607+50	RT.
STA. 607+00	TO	STA. 609+00	LT.
STA. 643+25	TO	STA. 645+50	RT.
STA. 701+55	TO	STA. 705+30	RT.
STA. 701+55	TO	STA. 707+00	LT.

- ① FOR SPECIAL DITCHES SEE PROFILE SHEETS & CROSS SECTIONS.
- ② SEE CROSS SECTIONS FOR MODIFIED BACKSLOPES.
- ③ GR. SLOPE IN RT. TN. / BY-PASS LN. TO MATCH FIN. LN. SLOPE.
- ④ 2.40' IN RT. TN. / BY-PASS LN. CONSTRUCTION.
- ⑤ SEE CHART W FOR LOCATIONS.
- ⑥ 14' IN BERM CONST. AREAS.
- ⑦ 27.91' IN RIGHT TURN LANES OR BYPASS
- ⑧ 21.71' IN SHLD. BERM SECTION
- ⑨ 29.21' IN TN. LN. / BY-PASS BERM SECTION

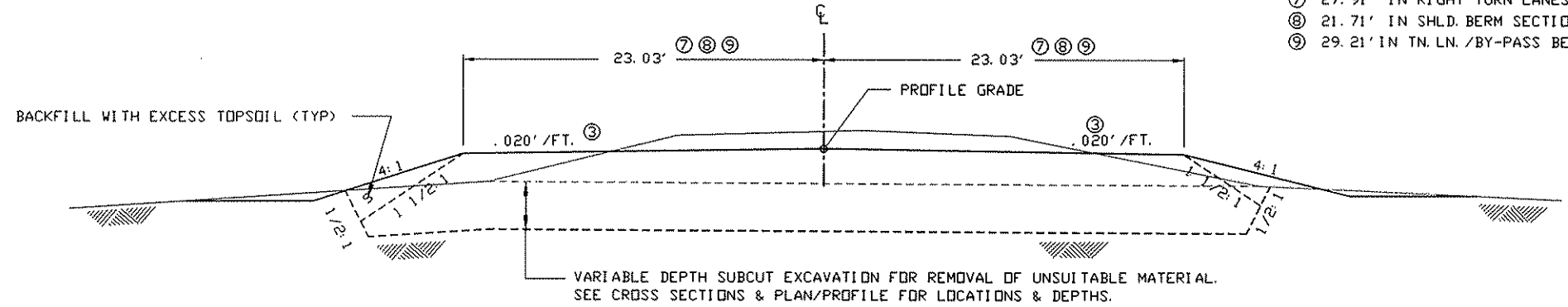

DESIGN F-3
(BITUMINOUS OVERLAY)

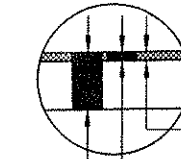

- MILL 1 1/2" DEEP PRIOR TO 1 1/2" OVERLAY
- 1 1/2" TYPE 31 WEARING COURSE—SPEC. 2340 BITUMINOUS MIXTURE DESIGNATION: 41WEA50055Y
- INPLACE BASE AND BITUMINOUS SURFACE
- TACK COAT—SPEC. 2357, TO BE APPLIED BETWEEN ALL BITUMINOUS LIFTS.

BITUMINOUS OVERLAY SECTION

STA. 709+43 TO STA. 711+23

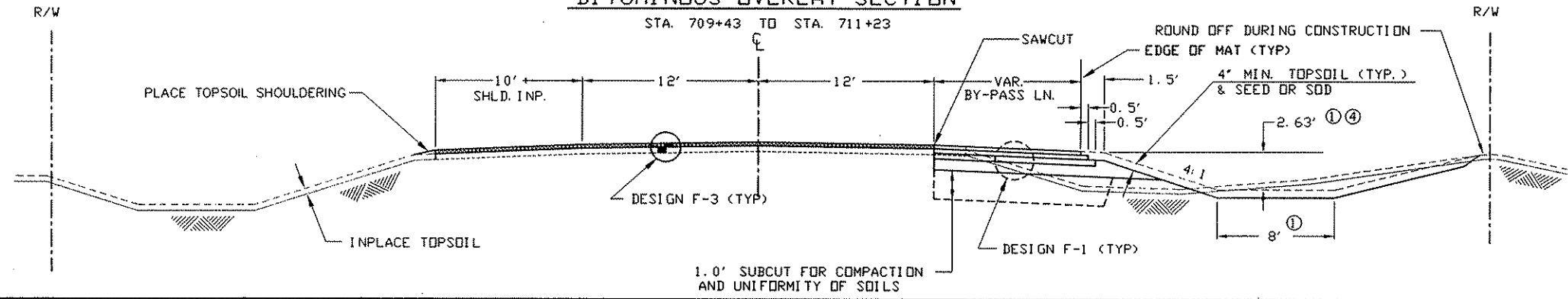

RIGHT TURN LANE AND BYPASS LOCATION (W)

STA. TO	STA.	LOCATION	REMARKS
499+30	504+39	LT.	RIGHT TURN LANE
631+04	637+14	RT	BY-PASS LANE
692+56	698+13	RT	RIGHT TURN LANE
696+99	702+51	LT	RIGHT TURN LANE
705+68	711+33	RT	BY-PASS LANE

NOTE:
NOT TO SCALE

TYPICAL SECTIONS

REVISIONS	DATE	BY

FILE NAME: S:\SDSKPROJ\940307\DWG\07TYP.DWG MN. (02-18-97)

TYPICAL UNPAVED ENTRANCE

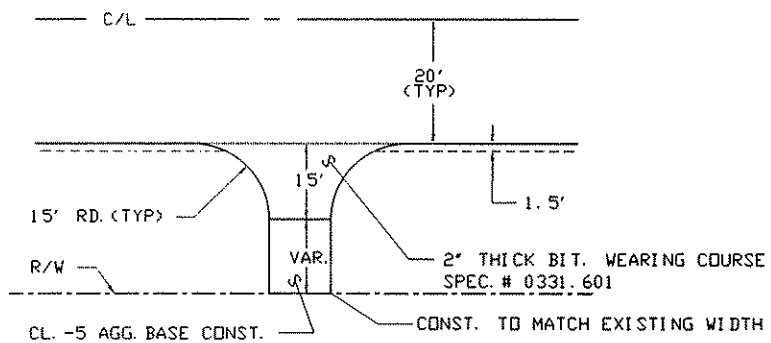

NOTE: ENTRANCE INSLOPE SHALL BE 6:1.

TYPICAL PAVED ENTRANCE

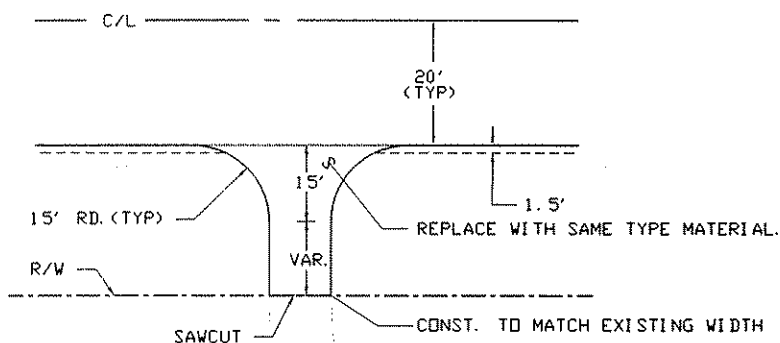

NOTE: ENTRANCE INSLOPE SHALL BE 6:1.

STREET APPROACHES

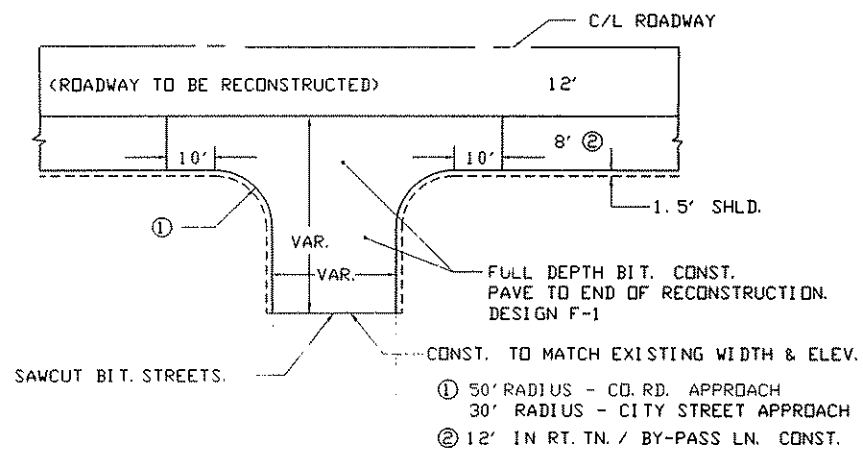

NOTE:
NOT TO SCALE

BERM DETAIL

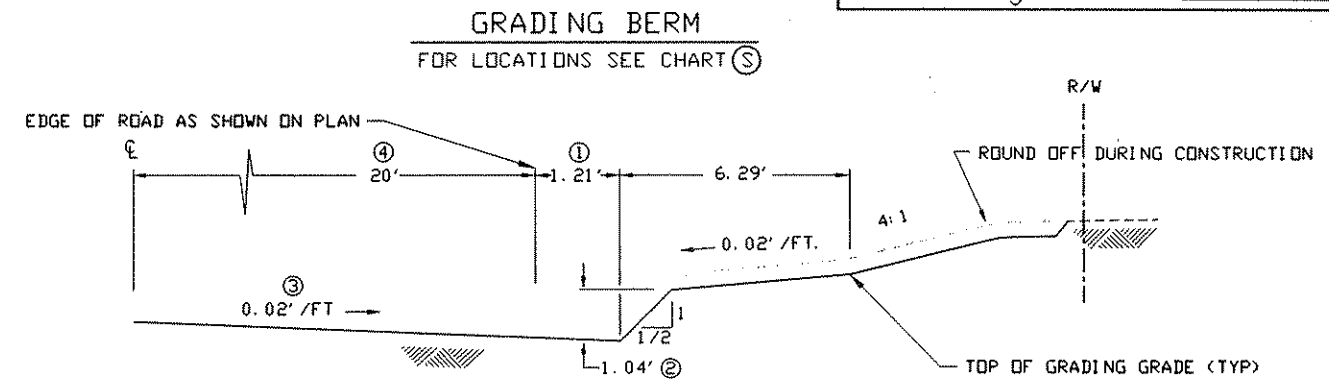

BITUMINOUS CURB DETAIL

STANDARD PLATE NO. 7065 C
(USE IN BERM LOCATIONS)

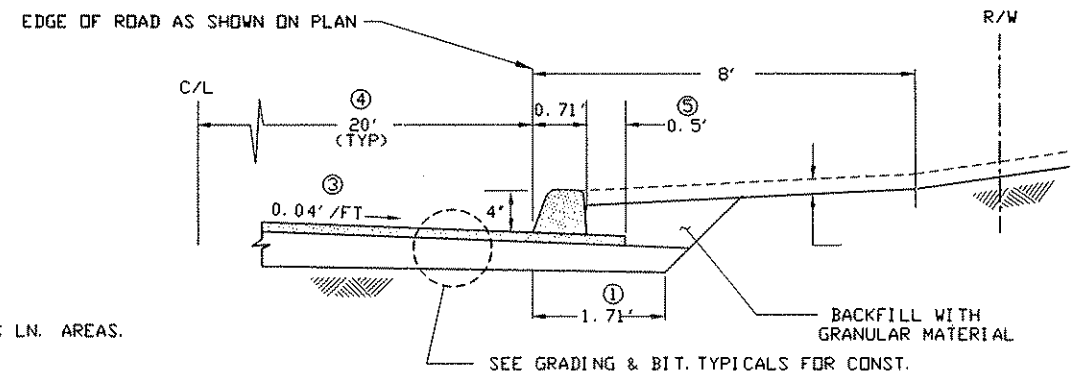

- ① 1.71' IN RT. TN. / BY-PASS LN. AREAS.
- ② 1.25' IN RT. TN. / BY-PASS LN. AREAS.
- ③ SEE GRADING TYP. FOR SLOPE RT. TN. / BY-PASS LN. AREAS.
- ④ 26' IN RT. TN. / BY-PASS LN. AREAS.
- ⑤ 1.5' IN RT. TN. / BY-PASS LN. AREAS.

**CONCRETE CURB & GUTTER DETAIL
ALTERNATE CONCRETE CURB & GUTTER**

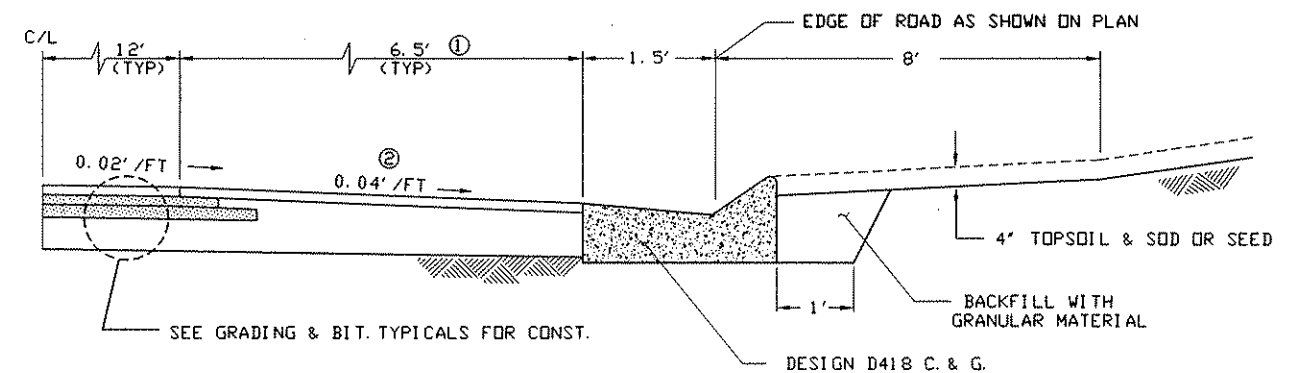

- ① 12.50' IN RT. TN. LN.
- ② 2.5% SLOPE IN RT. TR. LN.

BERM CONSTRUCTION LOCATION

STATION - STATION	LOCATION	REMARKS	LIN. FT.
499+50 - 501+70	26' LT		200
508+75 - 510+50	20' LT		175
562+30 - 569+40	20' RT		710
580+50 - 583+00	20' LT		250
590+57 - 592+50	20' LT		198
600+00 - 602+00	20' RT		200
604+00 - 606+76	20' RT		237
614+86 - 617+19	20' LT		233
632+50 - 635+25	20' RT		100
653+00 - 658+53	20' RT		553
657+00 - 658+76	20' RT		176
TOTAL			3716

TYPICAL SECTIONS

FILE NAME: S:\5056RPRO\940307\DWG\07TYP.DWG MN. (02-18-97)

REVISIONS	DATE	BY

B.M. #32 ELEV. 912.69
R.R. SPIKE IN P.P. S.W. COR.
CSAH 7 & 22 ELEV 912.69

B.M. #33 ELEV. 901.81
R.R. SPIKE IN 10" TRIPLE OAK
STA. 507+20, 100' RT.

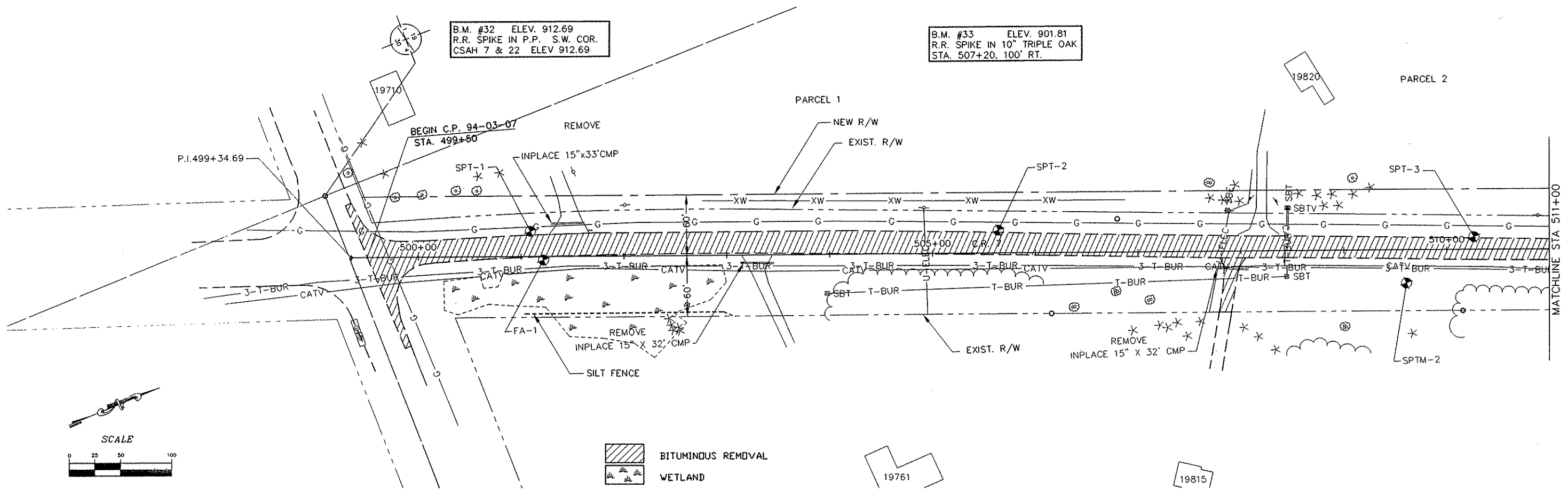

B.M. #34 ELEV. 899.03
R.R. SPIKE IN P.P.
STA. 513+90, 33' LT.

CURVE #1
PI = 519+61.72
D = 1'30"
Δ = 8'42'48" LT.
R = 3819.72'
T = 291.00'
L = 580.89'

B.M. #36 ELEV. 912.77
R.R. SPIKE 12" OAK
STA. 526+45, 59' RT.

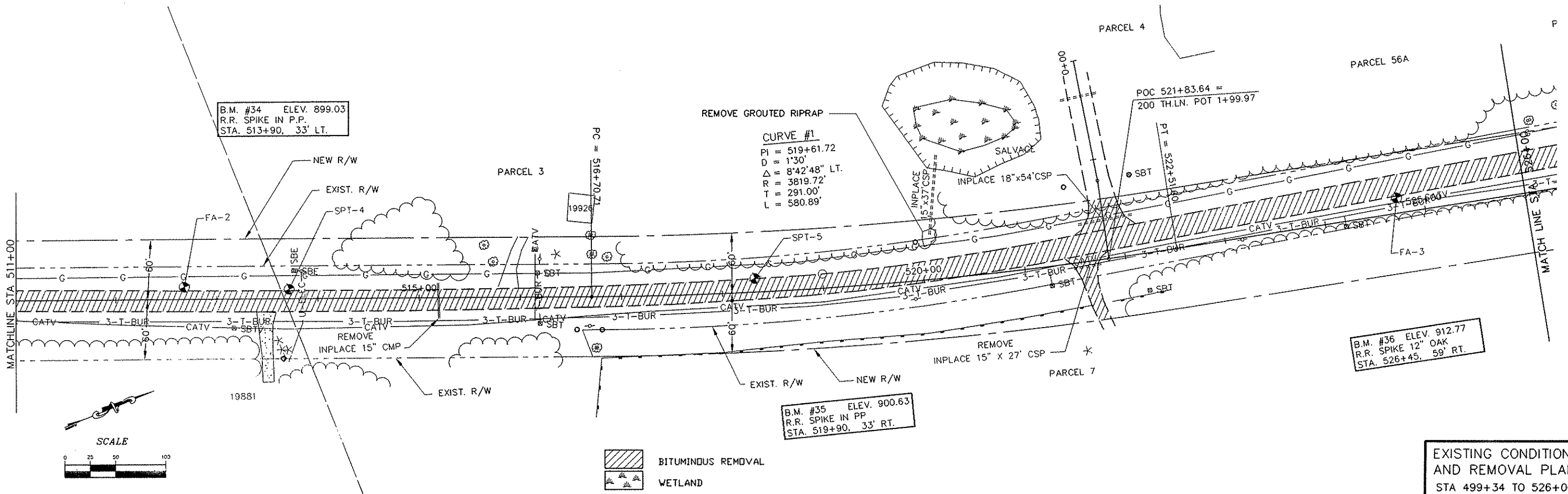

FILE NAME: S:\SDSR\PROJ\940307\DWG\SH1-REM.DWG, (02-18-97)

REVISIONS	DATE	BY

EXISTING CONDITION
AND REMOVAL PLAN
STA 499+34 TO 526+00

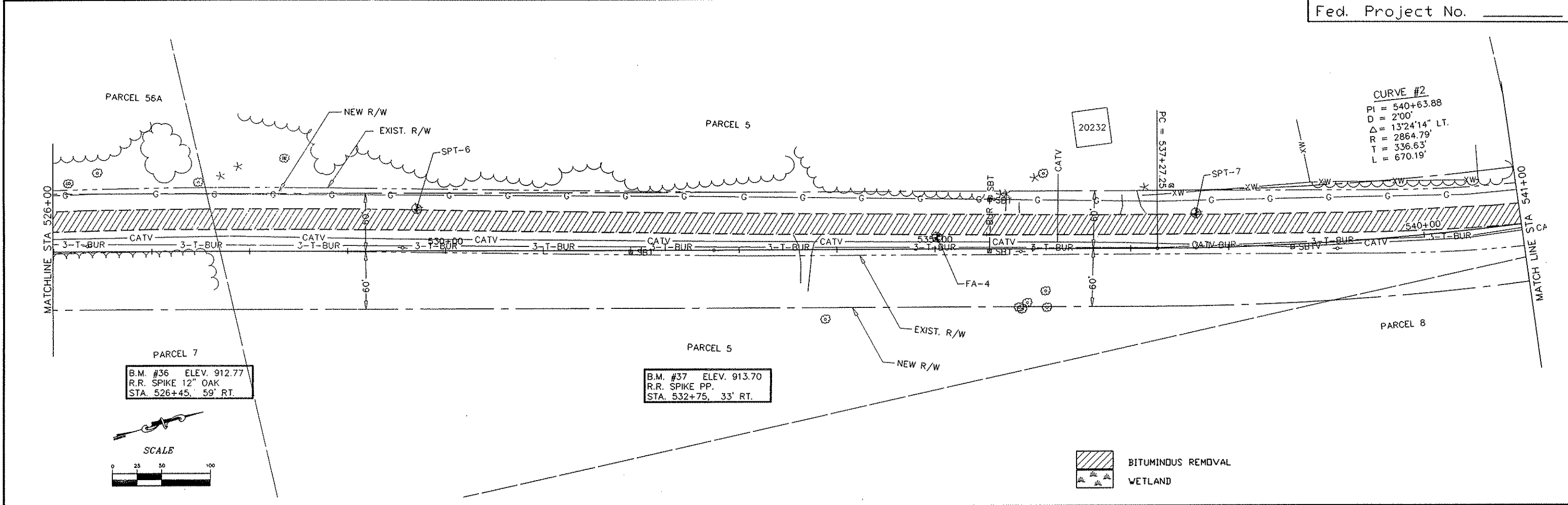

B.M. #36 ELEV. 912.77
R.R. SPIKE 12" OAK
STA. 526+45.59' RT.

B.M. #37 ELEV. 913.70
R.R. SPIKE PP.
STA. 532+75.33' RT.

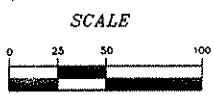

BITUMINOUS REMOVAL
 WETLAND

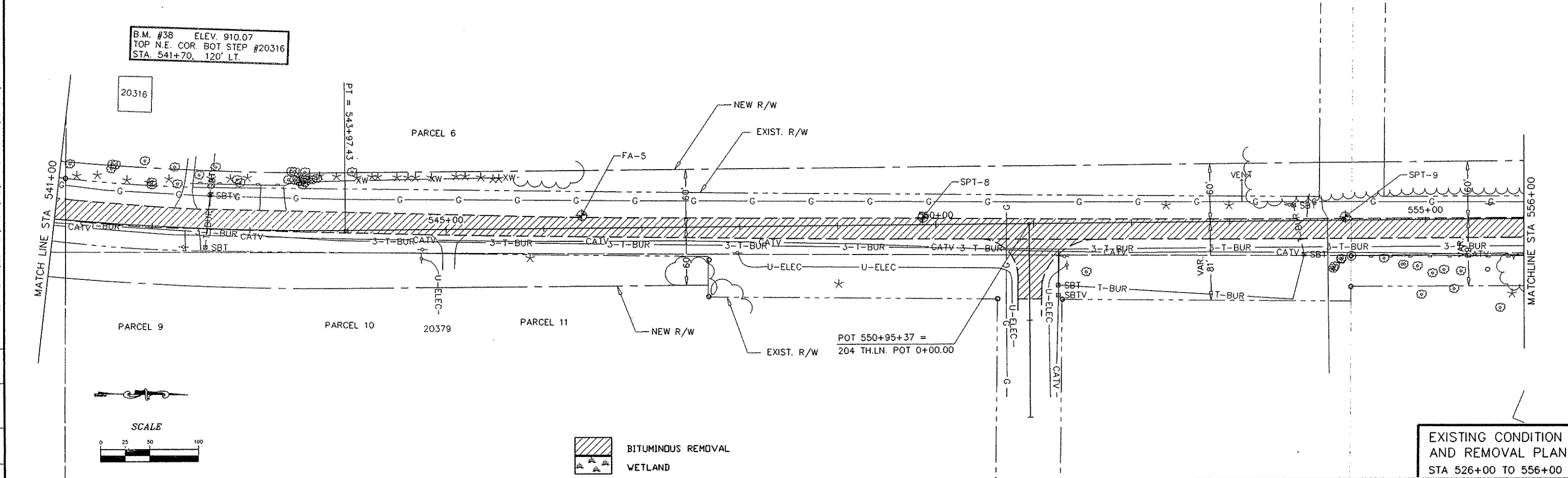

B.M. #38 ELEV. 910.07
TOP N.E. COR. BOT STEP #20316
STA. 541+70.120' LT.

POT 550+95+37 =
204 TH.LN. POT 0+00.00

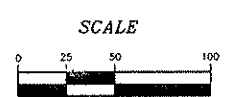

BITUMINOUS REMOVAL
 WETLAND

EXISTING CONDITION
AND REMOVAL PLAN
STA 526+00 TO 556+00

REVISIONS	DATE	BY

B.M. # 39 ELEV. 905.52
R.R. SPIKE IN PP
STA. 559+75, 33' LT.

B.M. #40 ELEV. 904.94
S.W. COR. GRANITE BASE FLAG POLE
STA. 564+50, IN CEMETARY

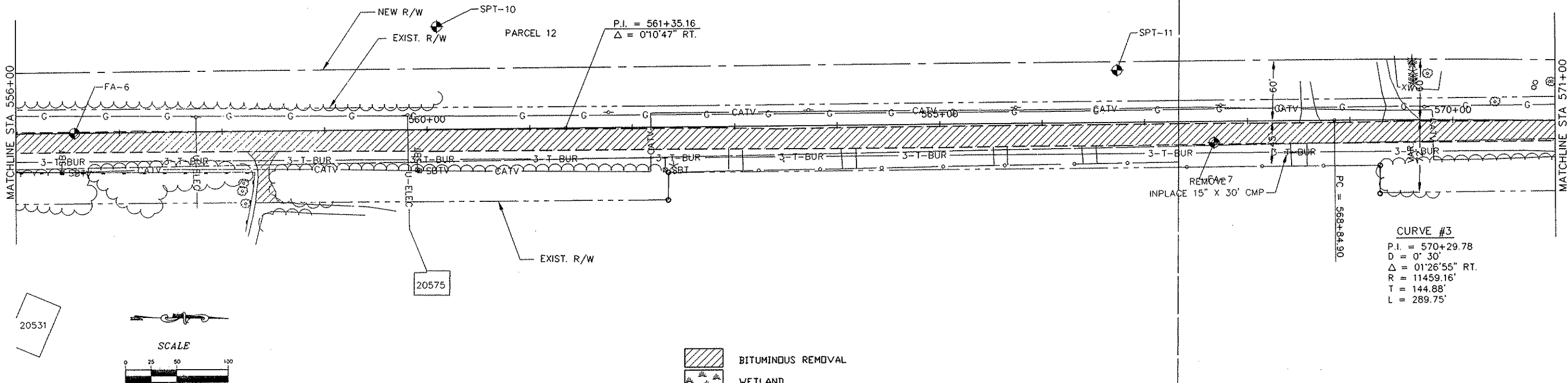

CURVE #3
P.I. = 570+29.78
D = 0' 30"
Δ = 01°26'55" RT.
R = 11459.16'
T = 144.88'
L = 289.75'

BITUMINOUS REMOVAL
 WETLAND

FILE NAME: S:\SDSK\SDSKPROJ\940307\DWG\SPJ-REM.DWG MN. (02-18-97)

B.M. #41 ELEV. 902.80
S.W. COR. CONC. SLAB #20746
STA. 571+60, 120' LT.

B.M. #42 ELEV. 899.75
R.R. SPIKE IN P.P.
STA. 575+80, 33' LT.

B.M. #43 ELEV. 901.98
R.R. SPIKE IN TRIPLE 18" OAK
STA. 580+50, 100' LT.

B.M. #44 ELEV. 896.58
R.R. SPIKE IN 8" POPIAR
STA. 584+94, 125' LT.

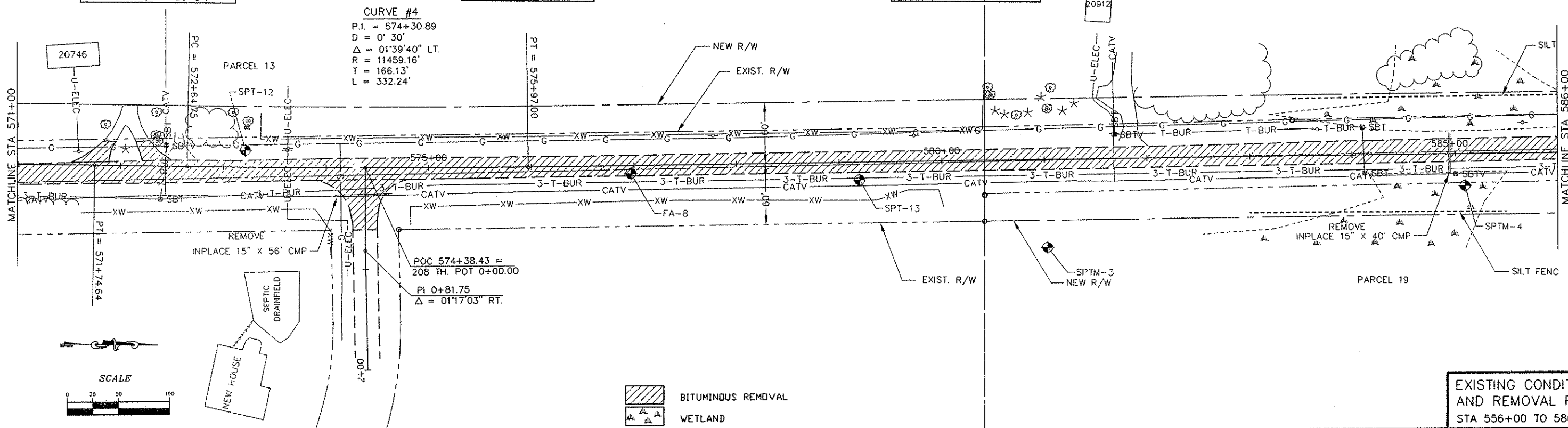

CURVE #4
P.I. = 574+30.89
D = 0' 30"
Δ = 01°39'40" LT.
R = 11459.16'
T = 166.13'
L = 332.24'

BITUMINOUS REMOVAL
 WETLAND

EXISTING CONDITION
AND REMOVAL PLAN
STA 556+00 TO 586+00

REVISIONS	DATE	BY

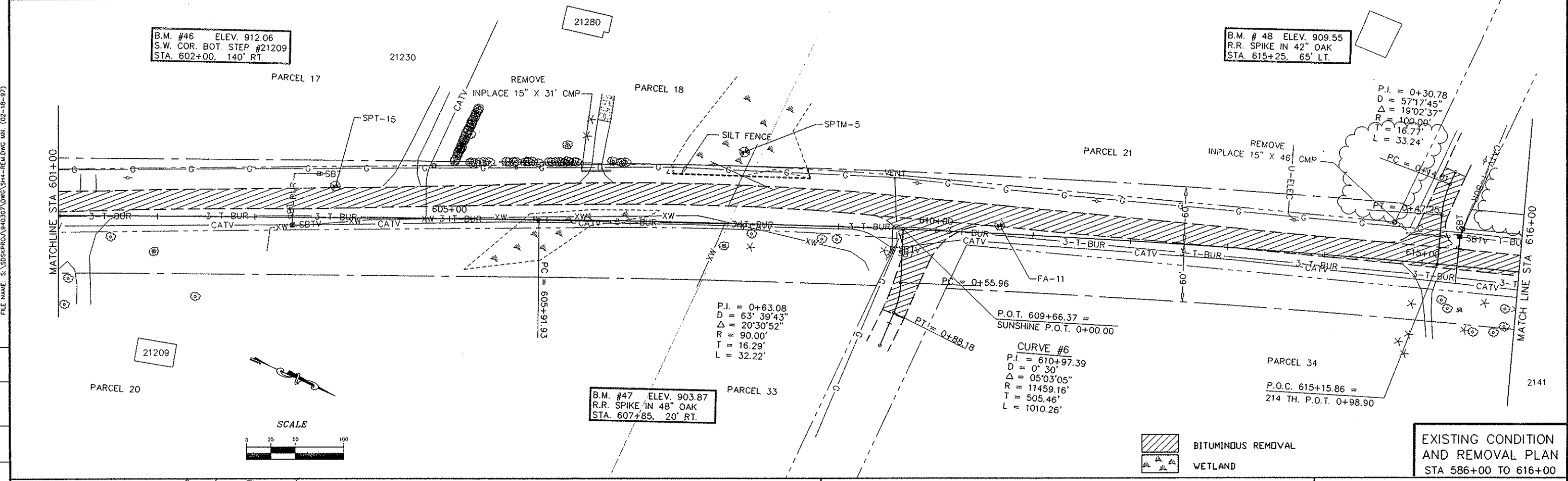
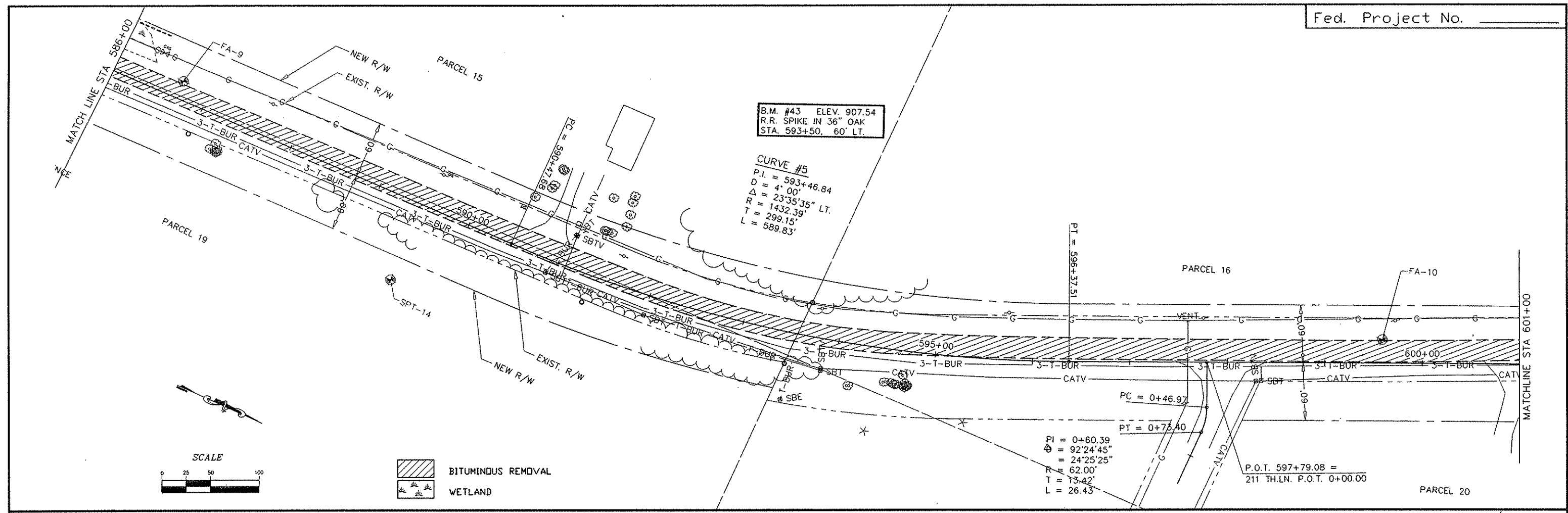

REVISIONS	DATE	BY

FILE NAME: S:\SDSPROJ\940307\DWG\SM4-REG.DWG MAX. (02-18-97)

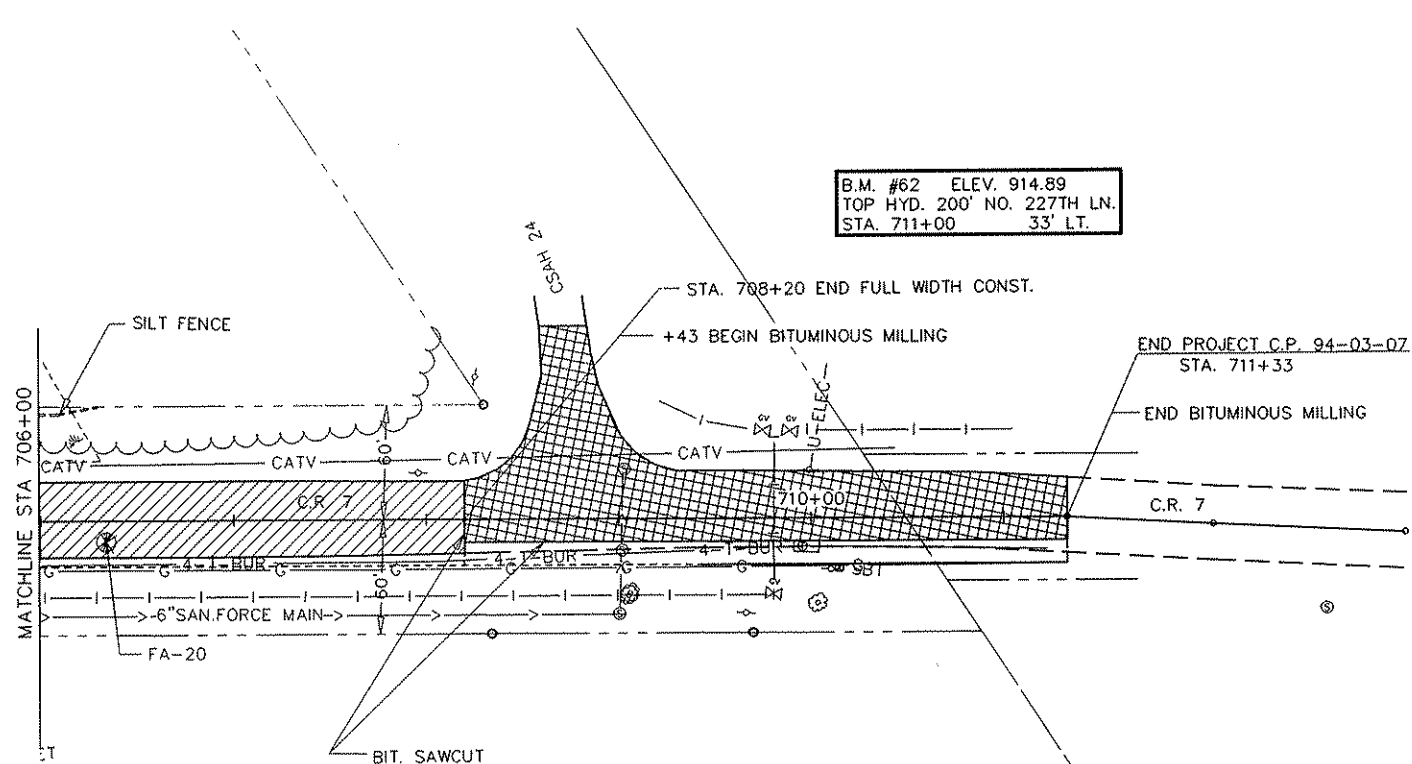

B.M. #62 ELEV. 914.89
 TOP HYD. 200' NO. 227TH LN.
 STA. 711+00 33' LT.

 BITUMINDUS REMOVAL
 BITUMINDUS MILLING
 WETLAND

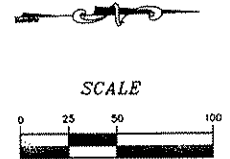

FILE NAME: S:\SDSKR\ROA\940307\DWG\SH8 - REM.DWG, MIN. (02-18-97)

REVISIONS	DATE	BY

EXISTING CONDITION
 AND REMOVAL PLAN
 STA 706+00 TO 711+33

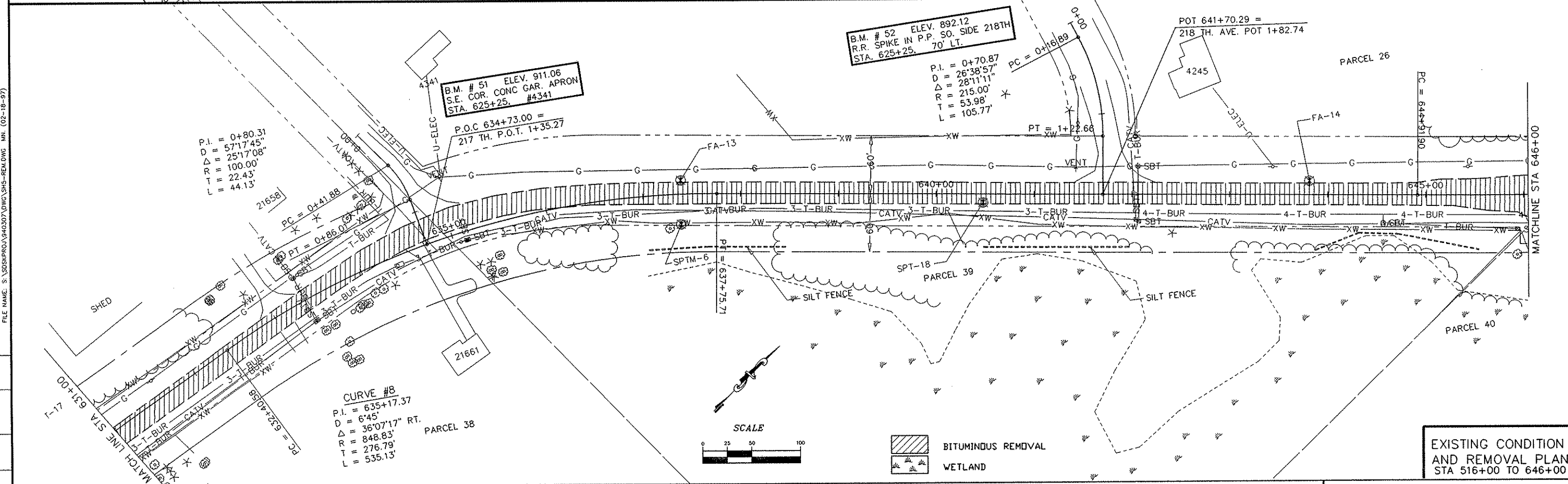
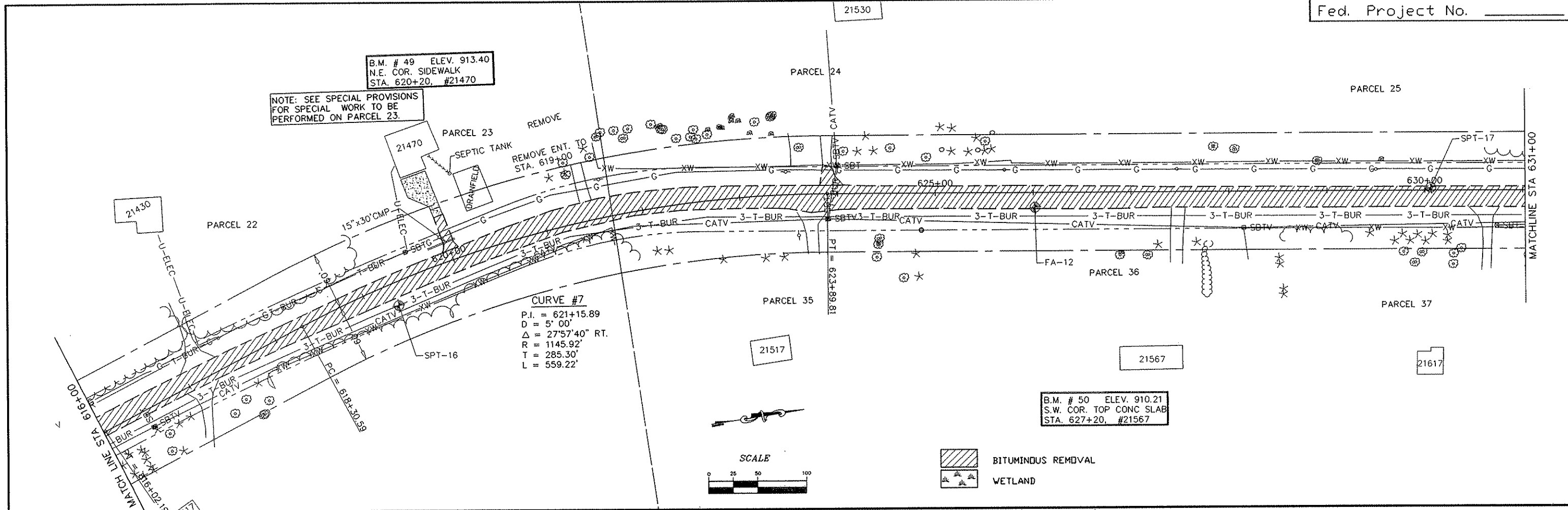

REVISIONS	DATE	BY

FILE NAME: S:\SDR\PROJ\940307\DWG\SPS-REM.DWG MN. (02-18-97)

EXISTING CONDITION AND REMOVAL PLAN STA 516+00 TO 646+00

B.M. # 53 ELEV. 886.91
TOP WEST BOLT N.E. ABUTMENT
STA. 649+00.

B.M. # 54 ELEV. 897.23
R.R. SPIKE IN P.P. S.W. COR.
STA. 653+10 219TH AVE.



CURVE #9
P.I. = 649+54.20
D = 0°45'
Δ = 06°55'34"
R = 7639.44'
T = 462.30'
L = 923.48'

PI = 0+75.92
D = 57°17'45"
Δ = 11°16'47"
R = 100.00'
T = 9.88'
L = 19.69'

CURVE #10
P.I. = 658+15.78
D = 0°15'
Δ = 00°56'35" LT.
R = 22918.31'
T = 188.61'
L = 377.20'

B.M. # 56 ELEV. 919.12
R.R. SPIKE IN P.P.
STA. 667+50 60' LT.

CURVE #11
P.I. = 666+83.56
D = 3°30'00"
Δ = 36°02'21" LT.
R = 1637.02'
T = 532.52'
L = 1029.69'

-  BITUMINOUS REMOVAL
-  1.5" BITUMINOUS MILLING
-  WETLAND

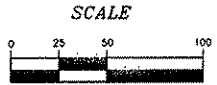

-  BITUMINOUS REMOVAL
-  WETLAND

EXISTING CONDITION
AND REMOVAL PLAN
STA 546+00 TO 676+00

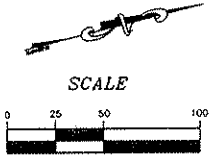
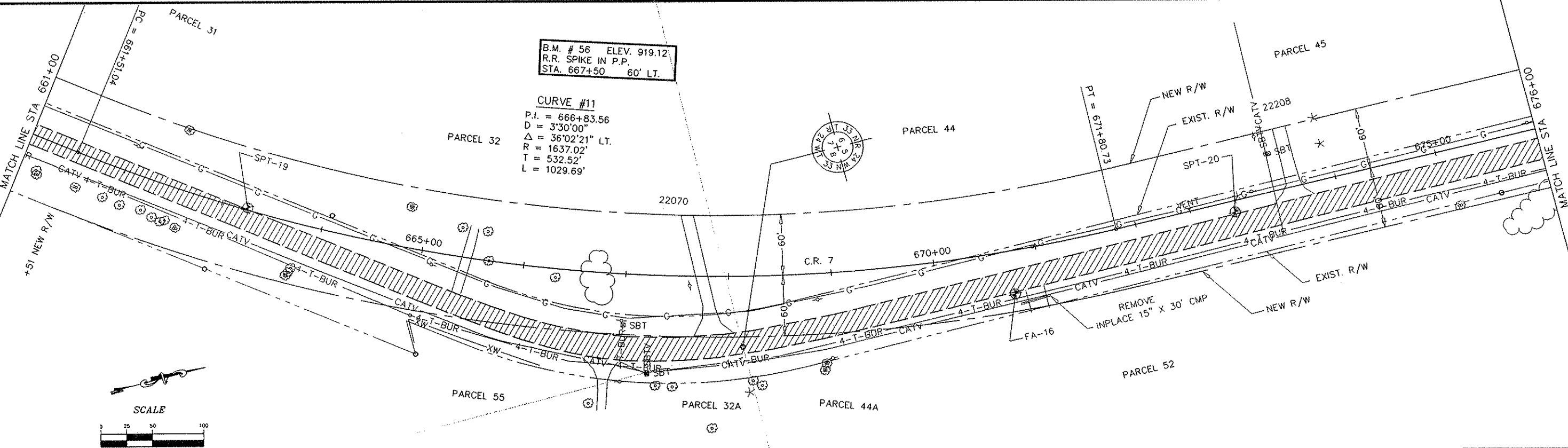

REVISIONS	DATE	BY

B.M. # 58 ELEV. 921.55
R.R. SPIKE IN 24" ELM
STA. 688+30 70' LT.

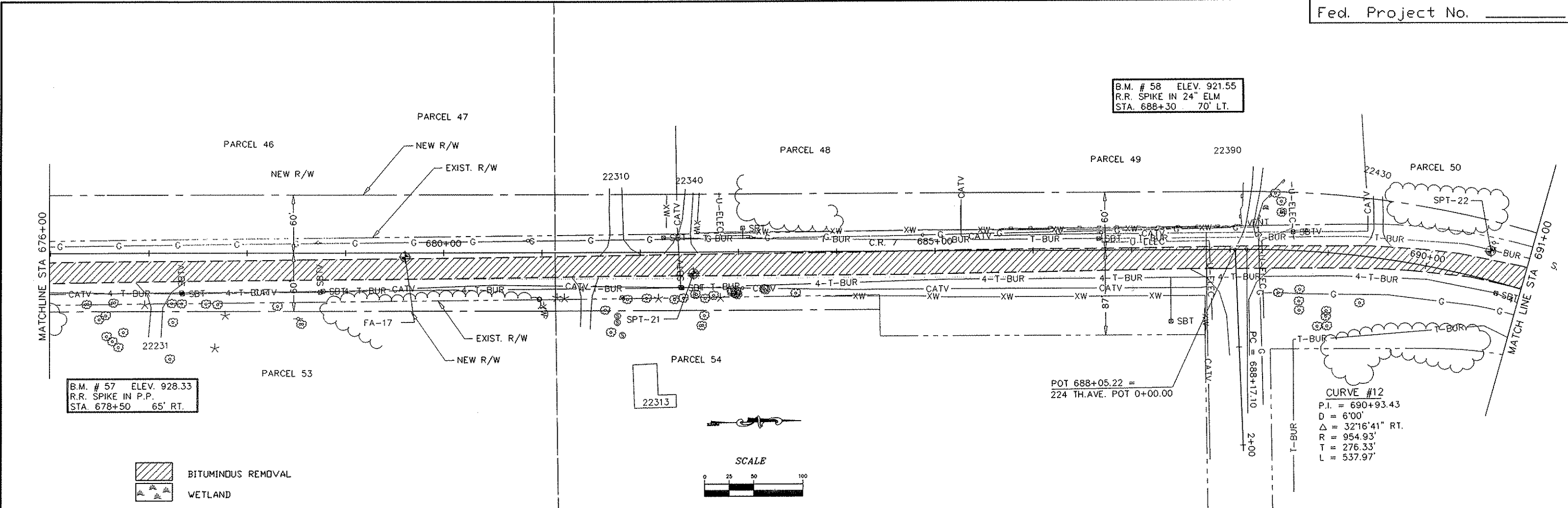

B.M. # 57 ELEV. 928.33
R.R. SPIKE IN P.P.
STA. 678+50 65' RT.

BITUMINDOUS REMOVAL
 WETLAND

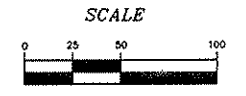

CURVE #12
P.I. = 690+93.43
D = 6'00"
Δ = 32'16".41" RT.
R = 954.93'
T = 276.33'
L = 537.97'

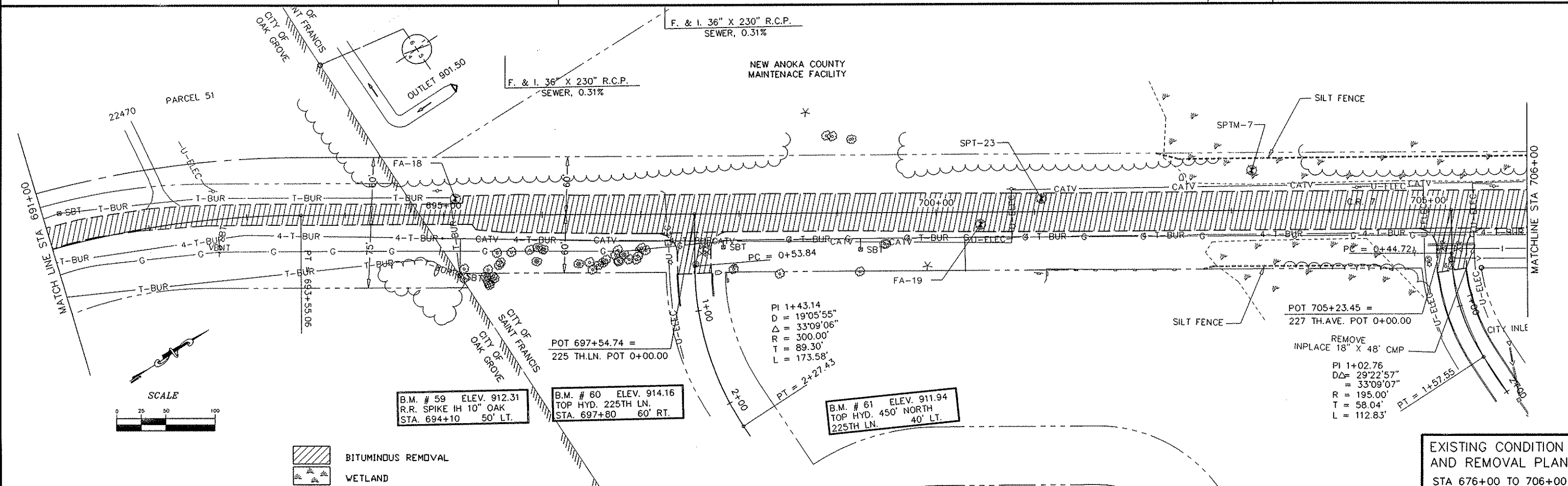

F. & I. 36" X 230" R.C.P.
SEWER, 0.31%

NEW ANOKA COUNTY
MAINTENANCE FACILITY

F. & I. 36" X 230" R.C.P.
SEWER, 0.31%

POT 705+23.45 =
227 TH.AVE. POT 0+00.00

REMOVE
INPLACE 18" X 48" CMP
PI 1+02.76
DΔ = 29'22".57"
= 33'09".07"
R = 195.00'
T = 58.04'
L = 112.83'

B.M. # 59 ELEV. 912.31
R.R. SPIKE IH 10" OAK
STA. 694+10 50' RT.

B.M. # 60 ELEV. 914.16
TOP HYD. 225TH LN.
STA. 697+80 60' RT.

B.M. # 61 ELEV. 911.94
TOP HYD. 450' NORTH
225TH LN. 40' LT.

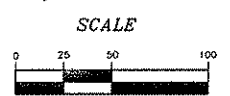

BITUMINDOUS REMOVAL
 WETLAND

**EXISTING CONDITION
AND REMOVAL PLAN**
STA 676+00 TO 706+00

REVISIONS	DATE	BY

CURVE # 1
 DEGREE = 1° 30' 00"
 DESIGN SPEED 55 MPH
 MAX e = 0.032/FT

CURVE # 2
 DEGREE = 2° 00' 00"
 DESIGN SPEED 55 MPH
 MAX e = 0.040/FT

CURVE # 5
 DEGREE = 4° 00' 00"
 DESIGN SPEED 55 MPH
 MAX e = 0.057/FT

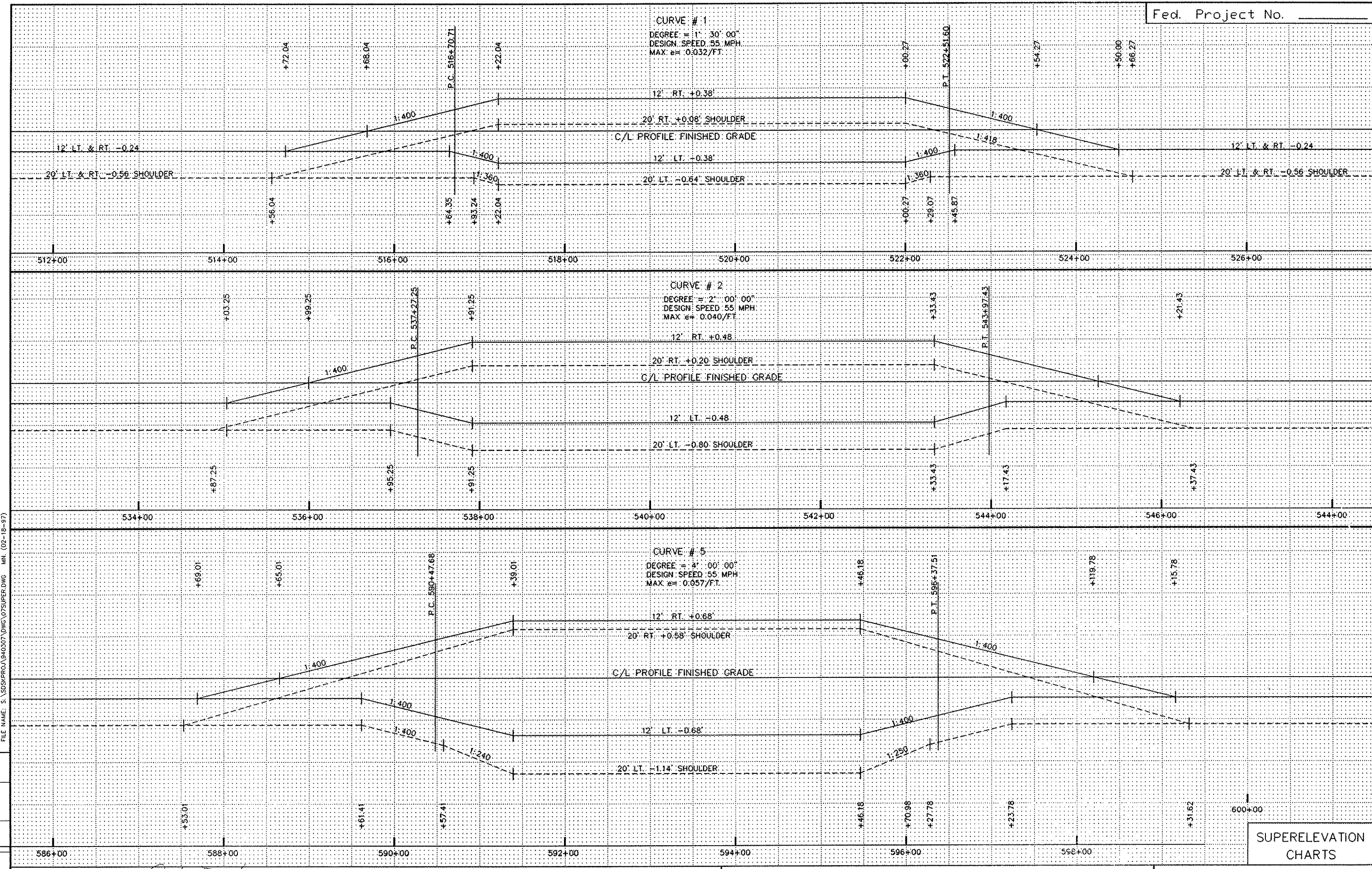

REVISIONS	DATE	BY

SUPERELEVATION CHARTS

FILE NAME: S:\SDSK\PROJ\940307\DWG\07SUPER.DWG MN. (02-18-97)

CURVE # 7
 DEGREE = 5° 00' 00"
 DESIGN SPEED 50 MPH
 MAX e = 0.056/FT.

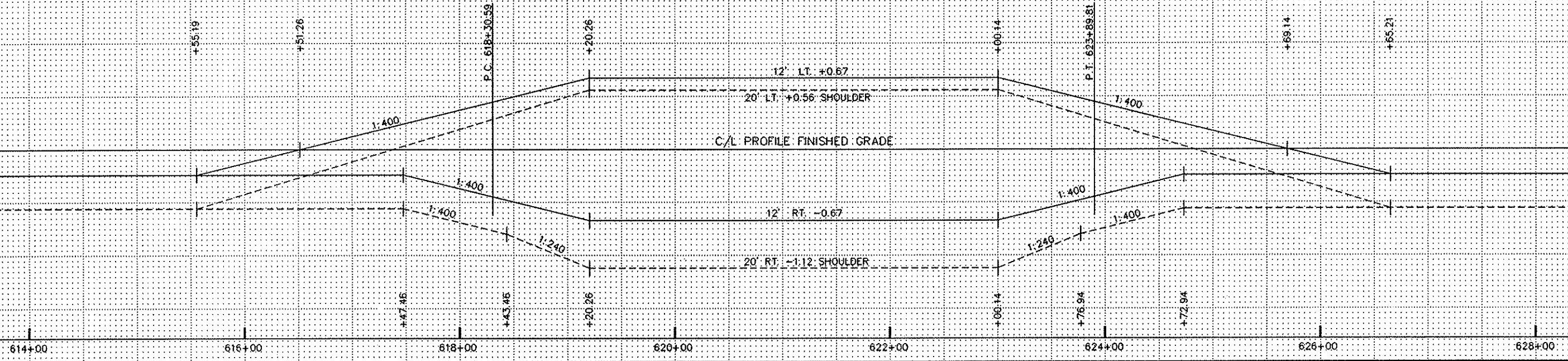

CURVE # 8
 DEGREE = 6° 45' 00"
 DESIGN SPEED 50 MPH
 MAX e = 0.060/FT.

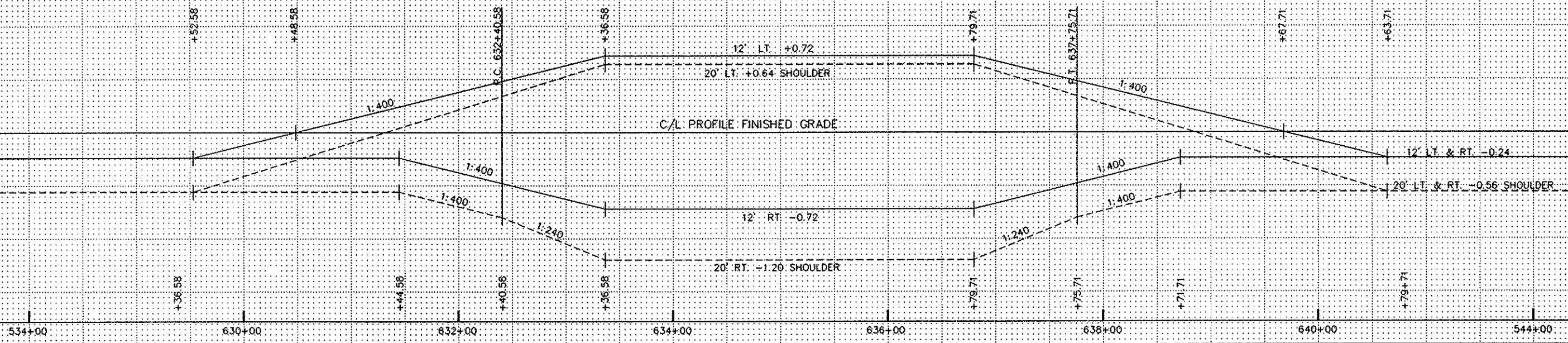

FILE NAME: S:\S056PROJ\940307\DWG\07SUPER.DWG MN. (02-18-97)

REVISIONS	DATE	BY

SUPERELEVATION CHARTS

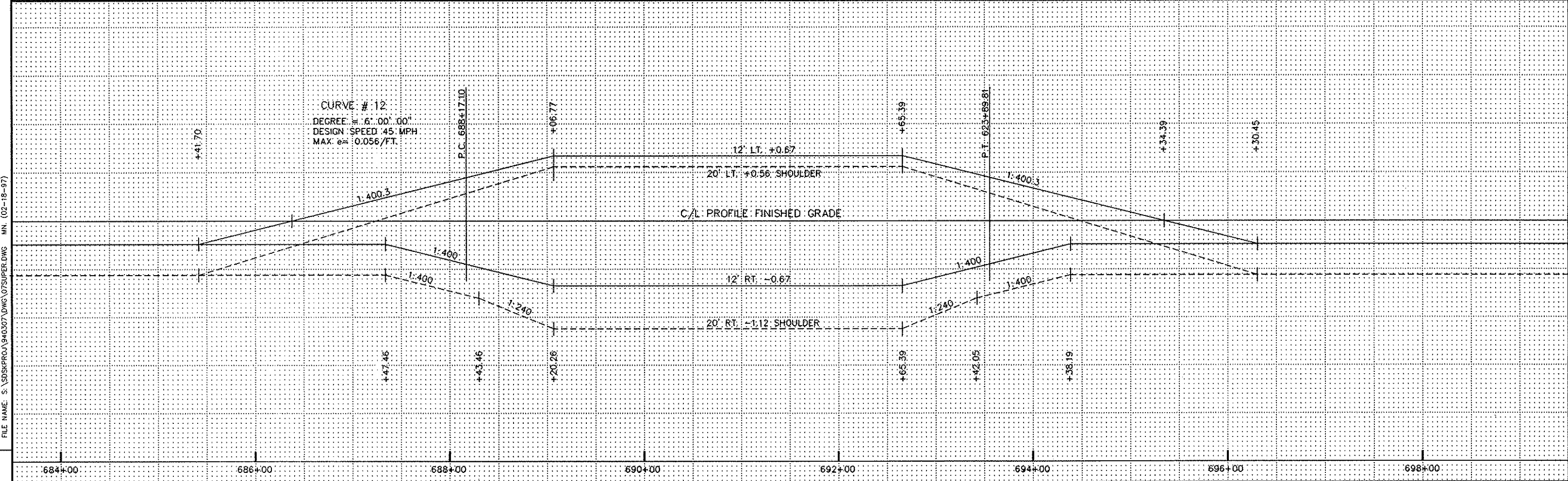
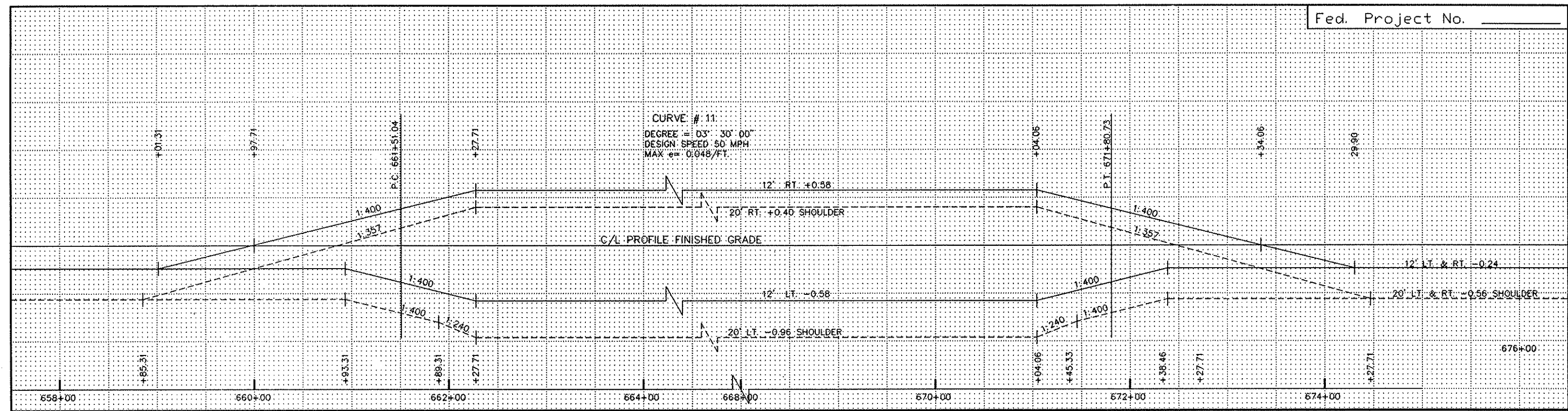

REVISIONS	BY	DATE

SUPERELEVATION CHARTS

FILE NAME: S:\SDSKPROJ\940307\DWG\07SUPER.DWG MN. (02-18-97)

B.M. #32 ELEV. 912.69
R.R. SPIKE IN P.P. S.W. COR.
CSAH 7 & 22 ELEV 912.69

B.M. #33 ELEV. 901.81
R.R. SPIKE IN 10" TRIPLE OAK
STA. 507+20, 100' RT.

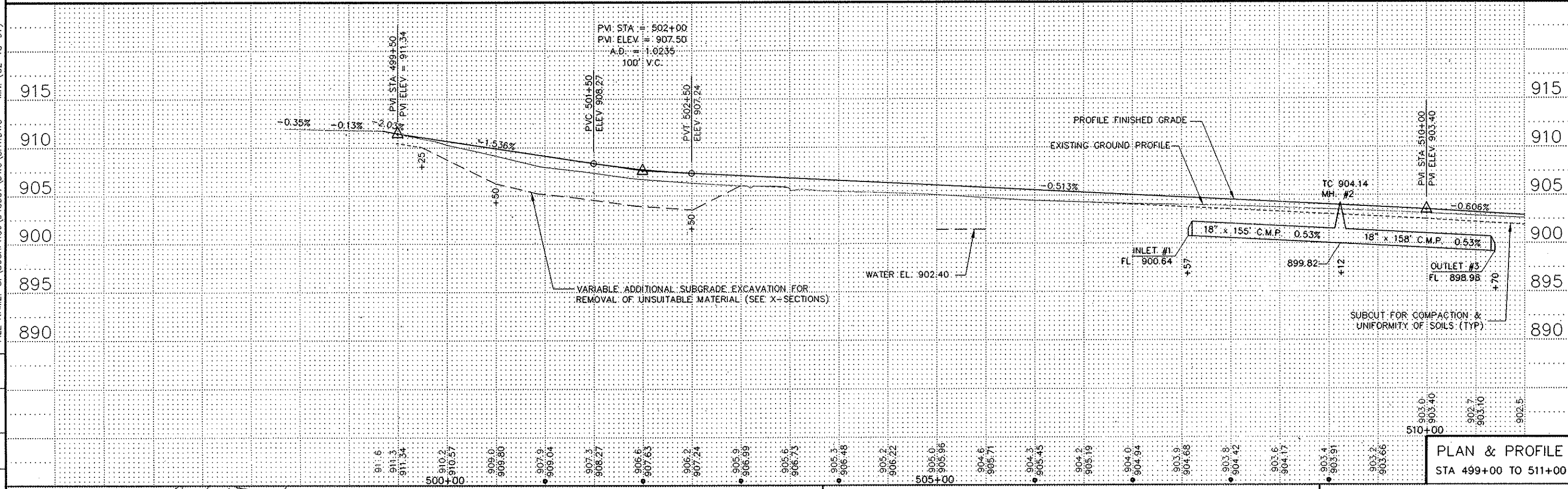
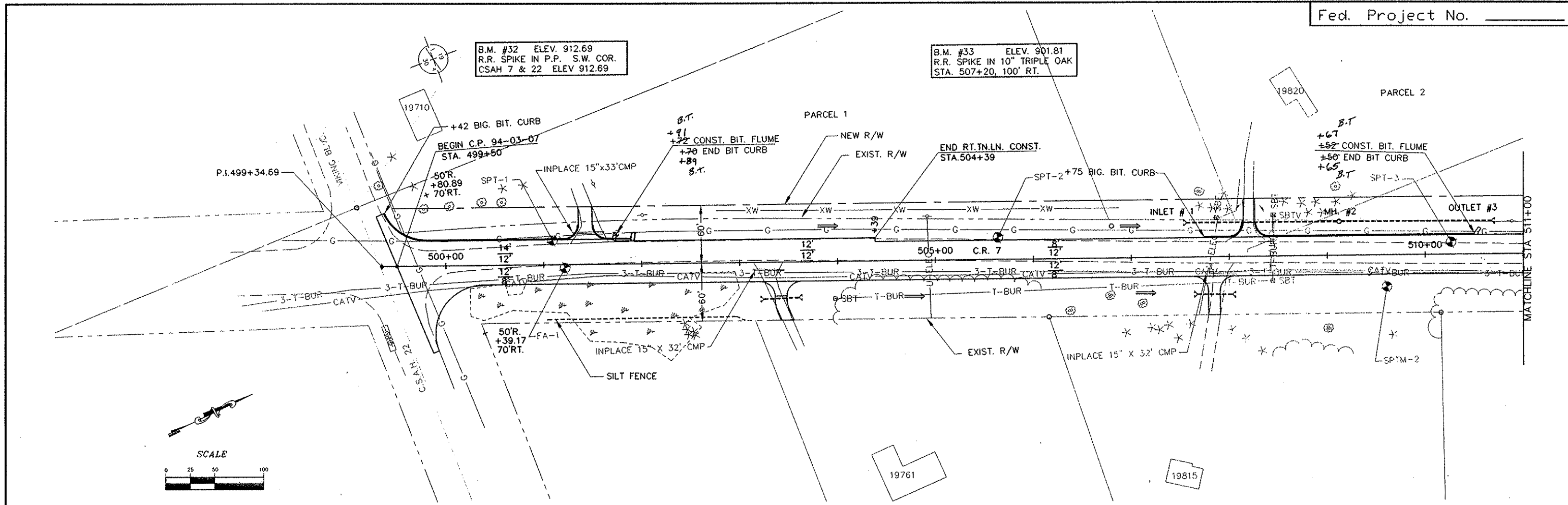

REVISIONS	DATE	BY

FILE NAME: S:\SOSKPROJ\940307\DWG\SH1.DWG MN. (02-18-97)

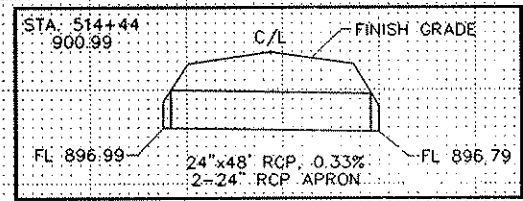
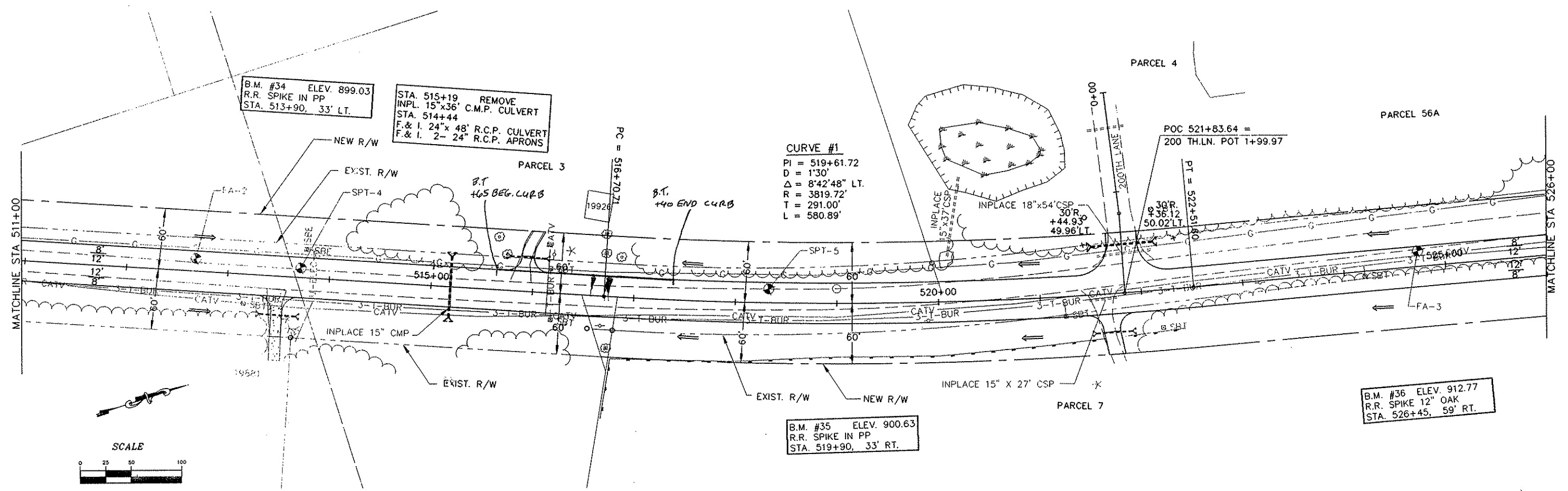

LOW POINT ELEV. = 900.99
 LOW POINT STA. = 514+43.5079
 PVI STA. = 514+50
 PVI ELEV. = 900.67
 A.D. = 1.2966
 200' VC

PVI STA. = 526+00
 PVI ELEV. = 909.48
 A.D. = -0.1737
 100' VC

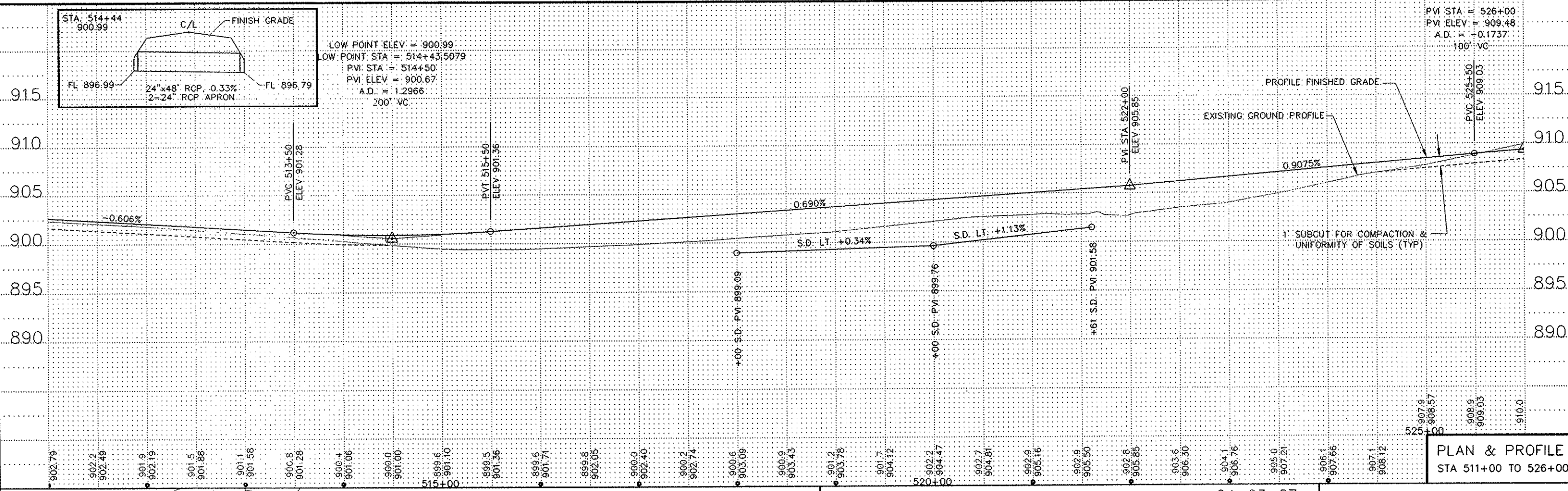

REVISIONS	DATE	BY

PLAN & PROFILE
 STA 511+00 TO 526+00

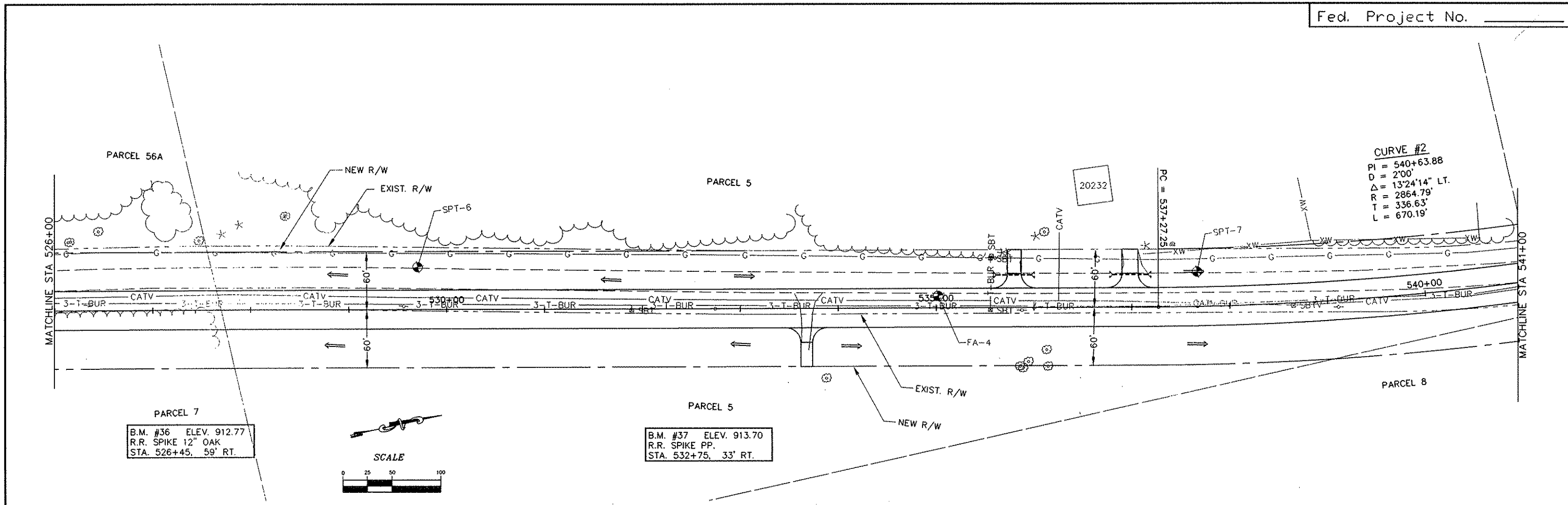

PARCEL 7
 B.M. #36 ELEV. 912.77
 R.R. SPIKE 12" OAK
 STA. 526+45, 59' RT.

PARCEL 5
 B.M. #37 ELEV. 913.70
 R.R. SPIKE PP.
 STA. 532+75, 33' RT.

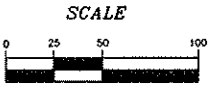

FILE NAME: S:\SOSKPROJ\940307\DWG\SH3.DWG MN. (02-18-97)

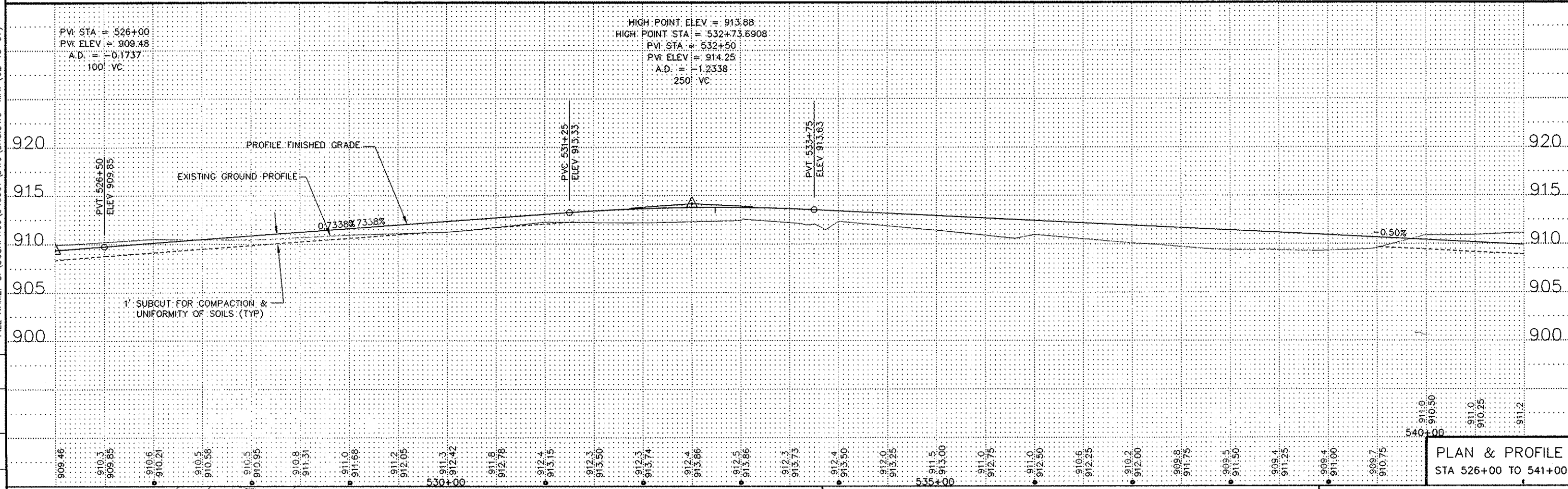

DATE	REVISIONS	BY

B.M. #38 ELEV. 910.07
TOP N.E. COR. BOT STEP #20316
STA. 541+70, 120' LT.

20316

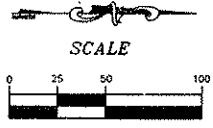
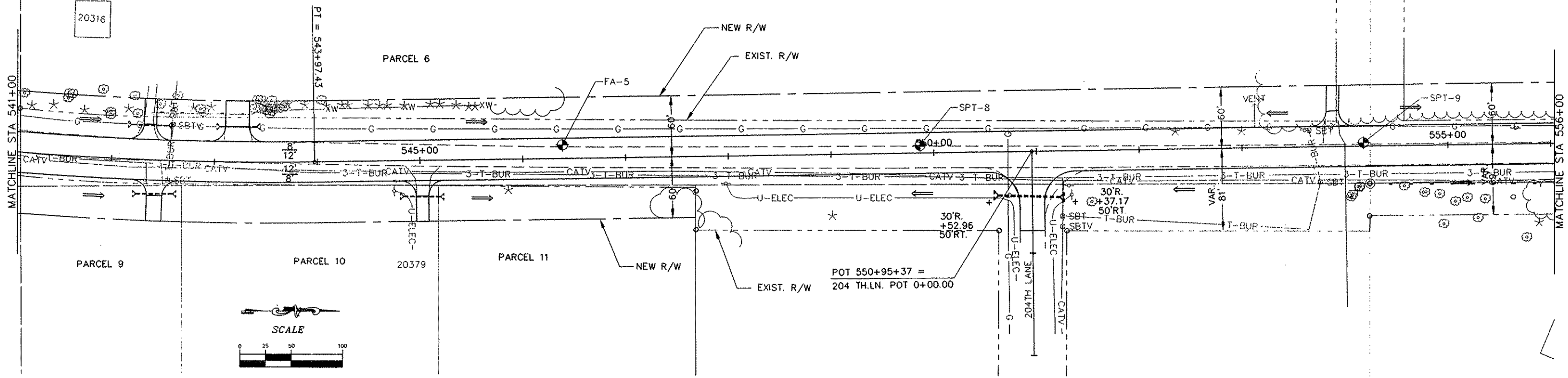

POT 550+95+37 =
204 TH.LN. POT 0+00.00

FILE NAME: S:\SDSK\PROJ\940307\DWG\SH4.DWG MN. (02-18-97)

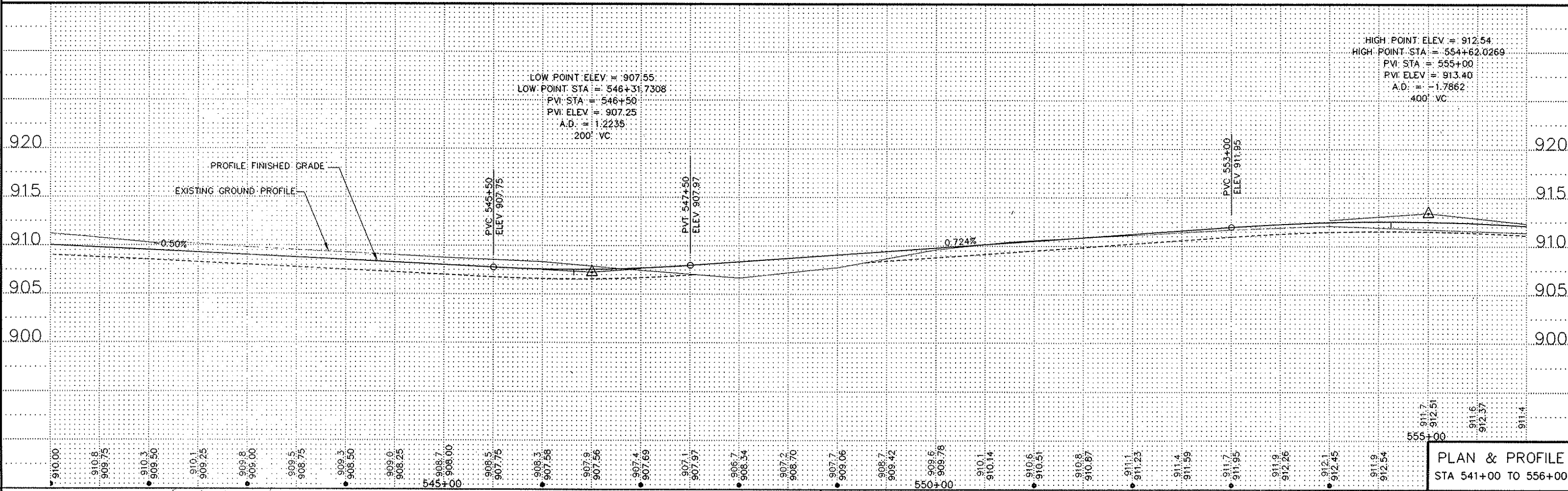

REVISIONS		
DATE	BY	DATE

B.M. # 39 ELEV. 905.52
R.R. SPIKE IN PP
STA. 559+75. 33' LT.

B.M. #40 ELEV. 904.94
S.W. COR. GRANITE BASE FLAG POLE
STA. 564+50. IN CEMETARY

STA. 562+14
F.& I. 24" x 48" R.C.P. CULVERT
F.& I. 2- 24" R.C.P. APRONS

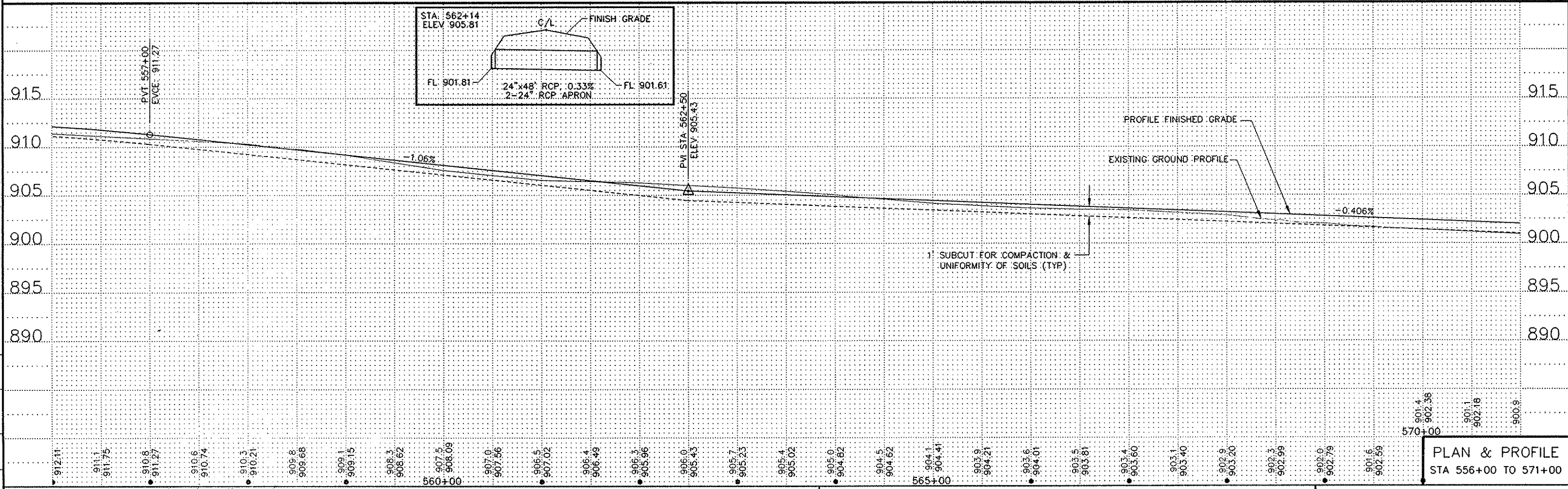
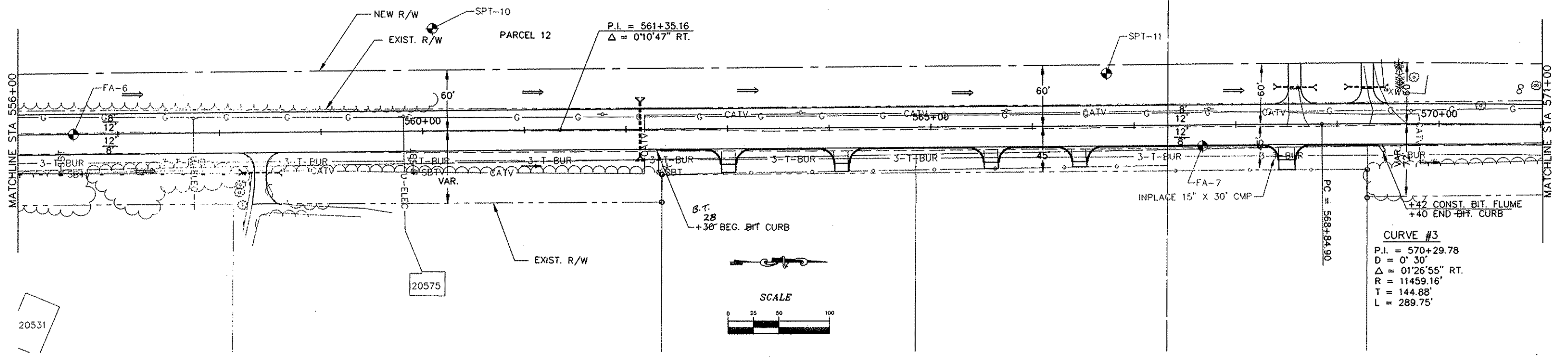

REVISIONS	DATE	BY

FILE NAME: S:\SDSK\PROJ\DWG\940307\SH05.DWG MN. (02-18-97)

PLAN & PROFILE
STA 556+00 TO 571+00

B.M. #41 ELEV. 902.80
S.W. COR. CONC. SLAB #20746
STA. 571+60, 120' LT.

B.M. #42 ELEV. 899.75
R.R. SPIKE IN P.P.
STA. 575+80, 33' LT.

B.M. #43 ELEV. 901.98
R.R. SPIKE IN TRIPLE 18" OAK
STA. 580+50, 100' LT.

B.M. #44 ELEV. 896.58
R.R. SPIKE IN 8" POPIAR
STA. 584+94, 125' LT.

STA. 583+89
REMOVE
INPL. 15"x40' C.M.P. CULVERT
F. & I. 24"x 48' R.C.P. CULVERT
F. & I. 2- 15" R.C.P. APRONS

CURVE #4
P.I. = 574+30.89
D = 0' 30"
Δ = 01'39"40" LT.
R = 11459.16'
T = 166.13'
L = 332.24'

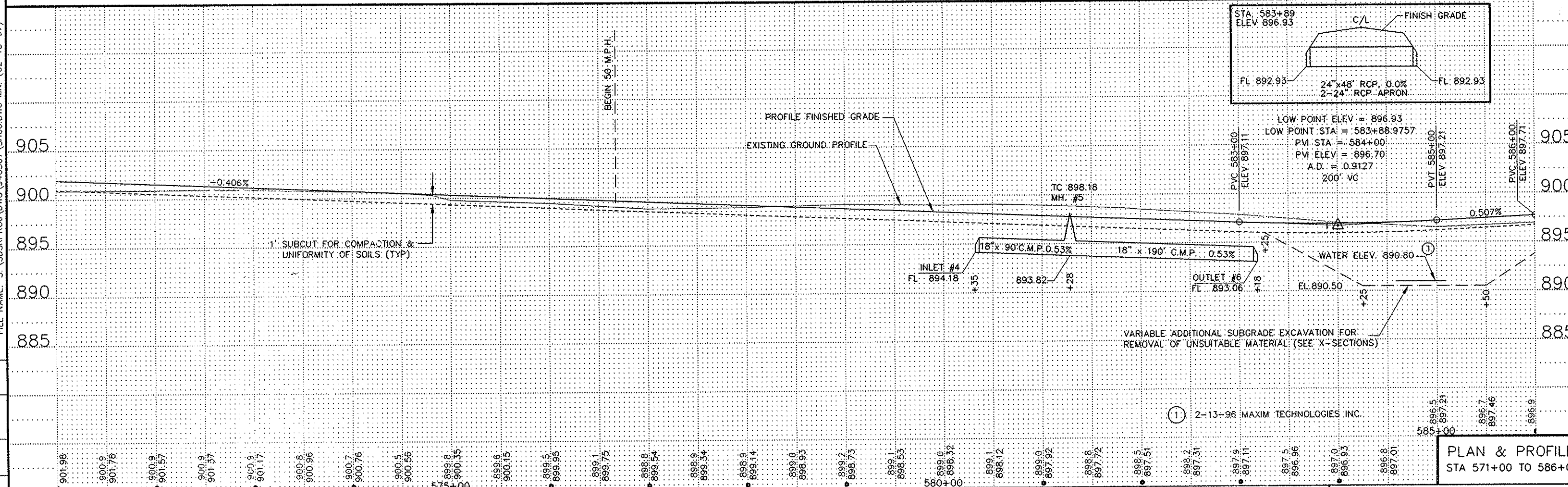
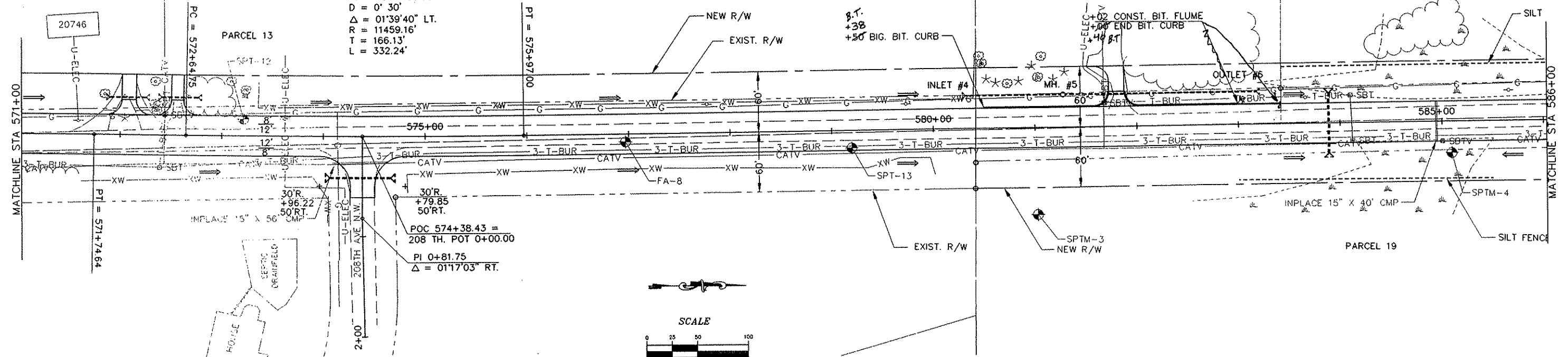

PLAN & PROFILE
STA 571+00 TO 586+00

REVISIONS	BY	DATE	BY

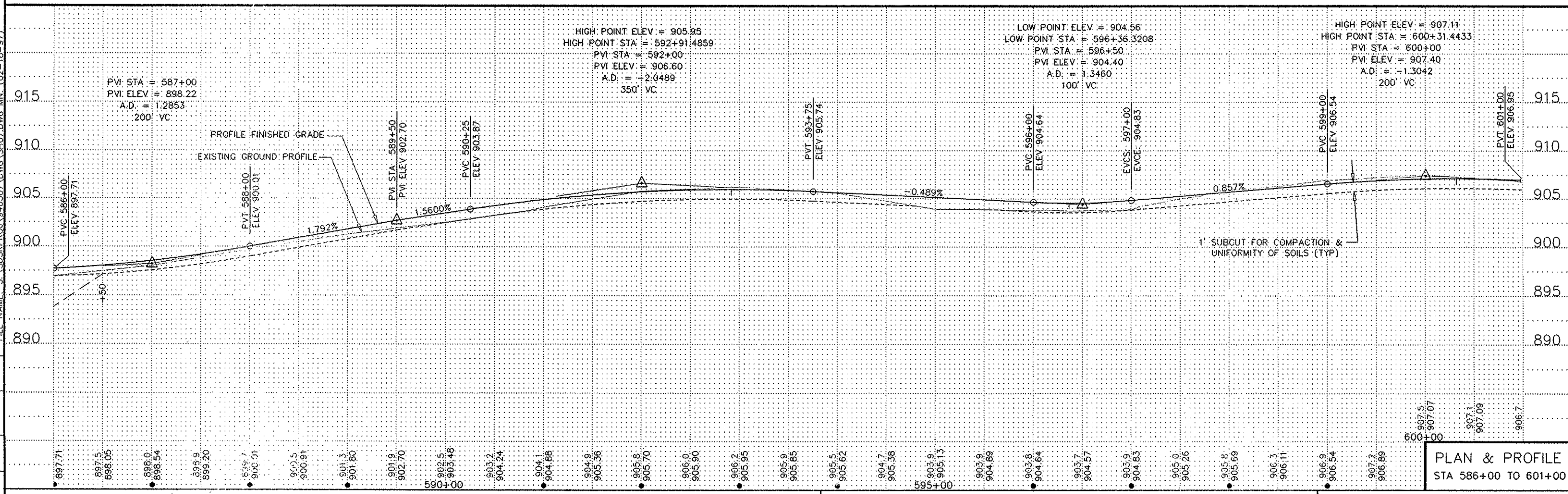
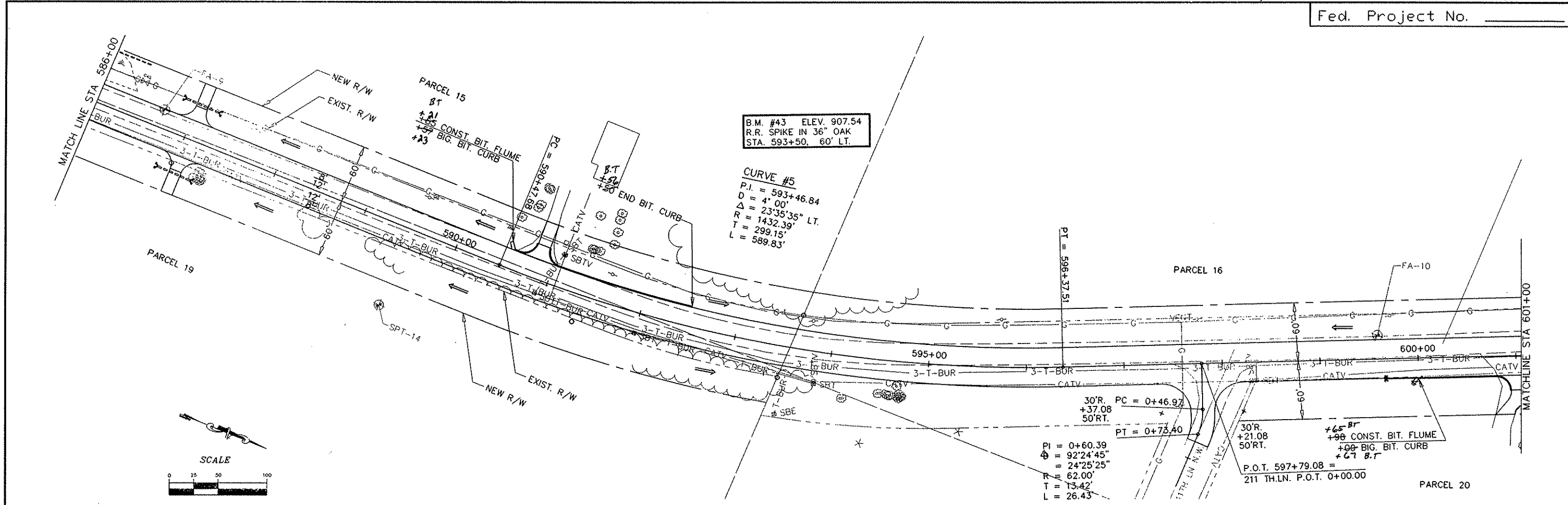

REVISIONS	DATE	BY

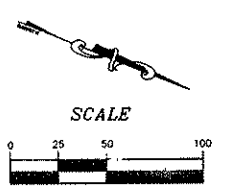
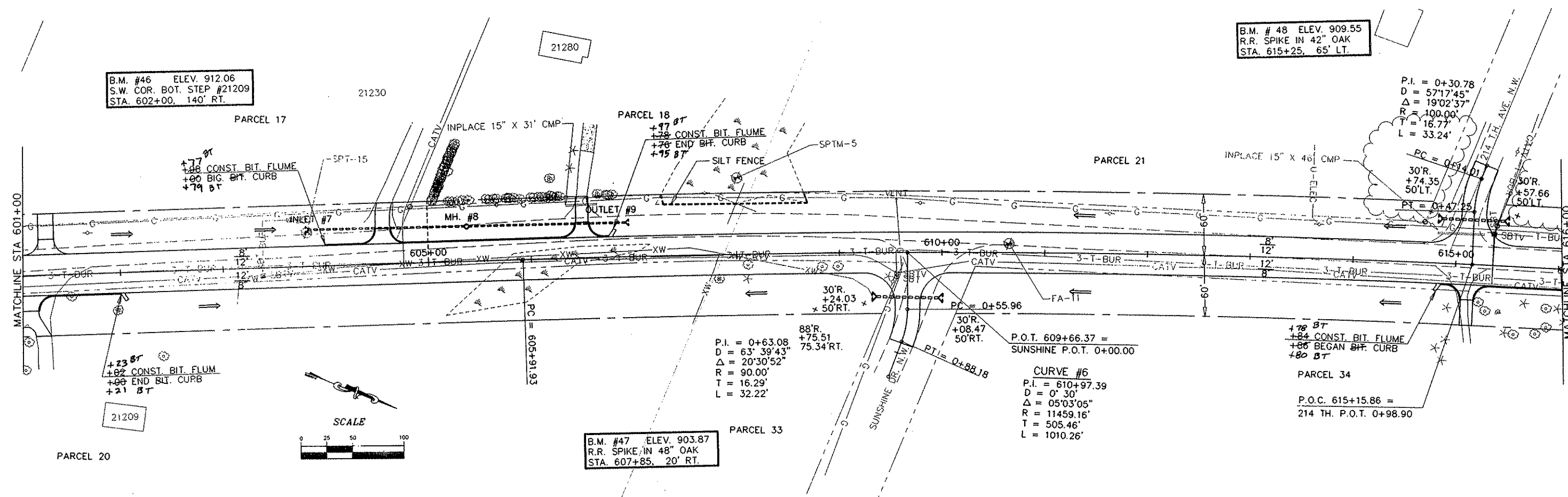

LOW POINT ELEV = 903.93
 LOW POINT STA = 608+03.2370
 PVI STA = 608+50
 PVI ELEV = 903.60
 A.D. = 1.6795
 200' VC

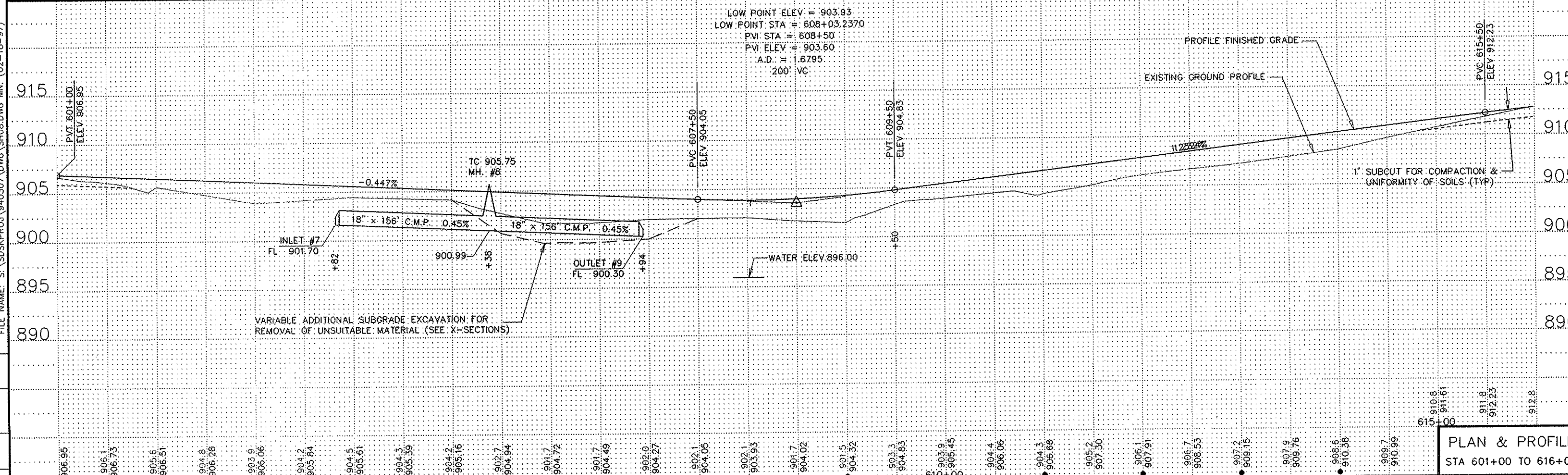

REVISIONS	DATE	BY

FILE NAME: S:\SDSKPROJ\940307\DWG\SH08.DWG MN. (02-18-97)

B.M. # 49 ELEV. 913.40
N.E. COR. SIDEWALK
STA. 620+20. #21470

STA. 628+45
F. & I. 24" x 52" R.C.P. CULVERT
F. & I. 2- 24" R.C.P. APRONS

NOTE: SEE SPECIAL PROVISIONS
FOR SPECIAL WORK TO BE
PERFORMED ON PARCEL 23.

CURVE #7
P.I. = 621+15.89
D = 5' 00"
Δ = 27°57'40" RT.
R = 1145.92'
T = 285.30'
L = 559.22'

B.M. # 50 ELEV. 910.21
S.W. COR. TOP CONC SLAB
STA. 627+20. #21567

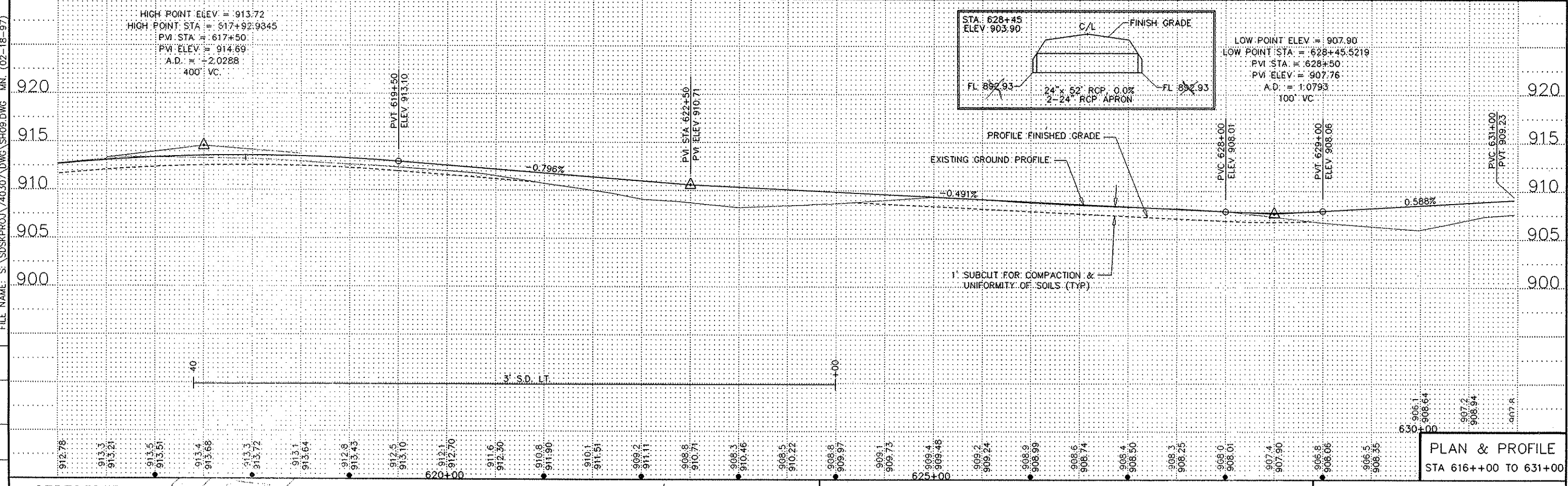
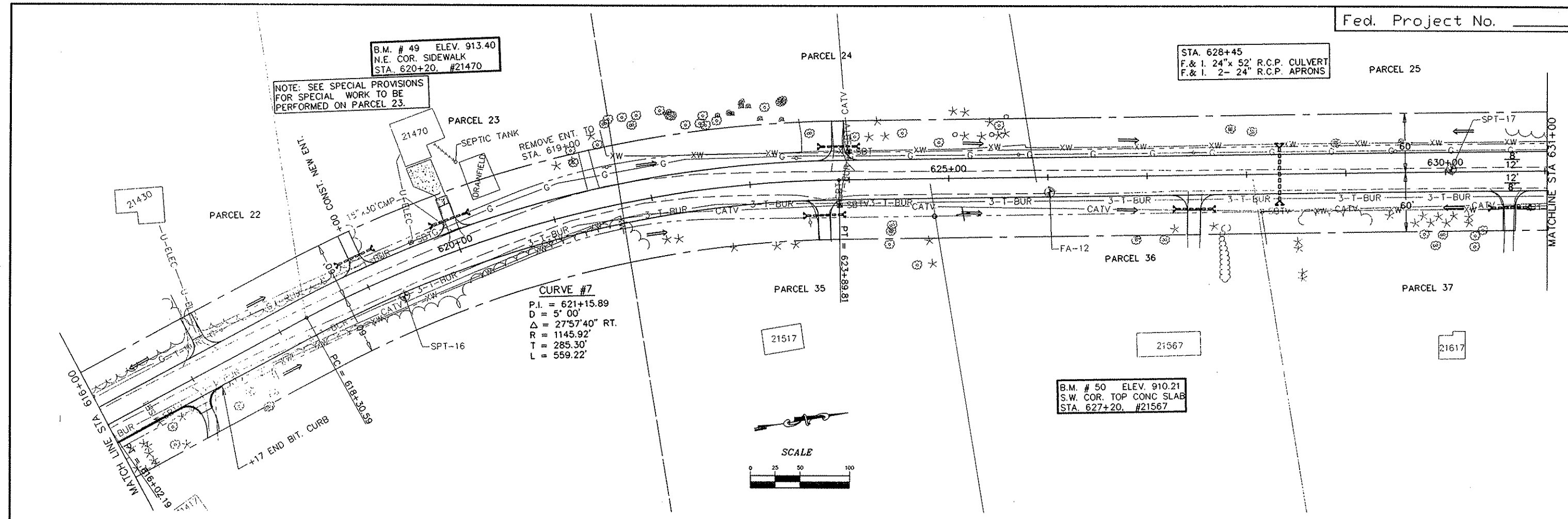
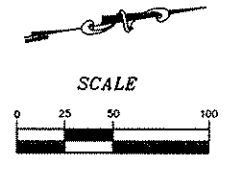

FILE NAME: S:\SDSKPROJ\740307\DWG\SH09.DWG MN. (02-18-97)

REVISIONS	DATE	BY

PLAN & PROFILE
STA 616+00 TO 631+00

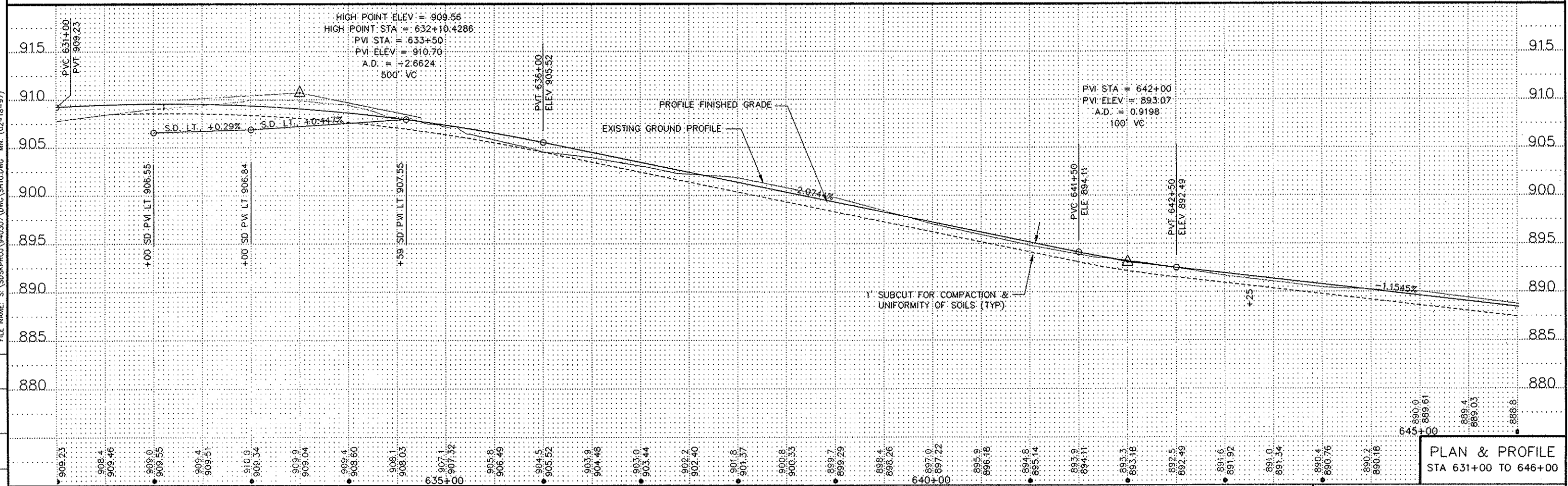
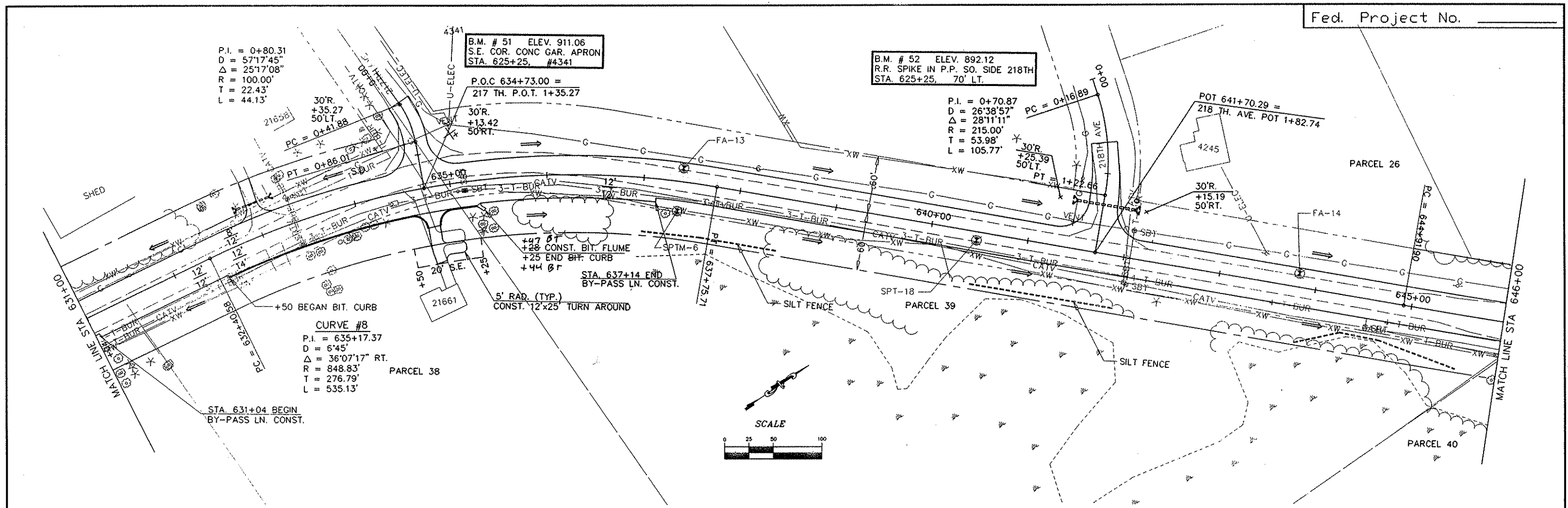

REVISIONS	DATE	BY

PLAN & PROFILE
STA 631+00 TO 646+00

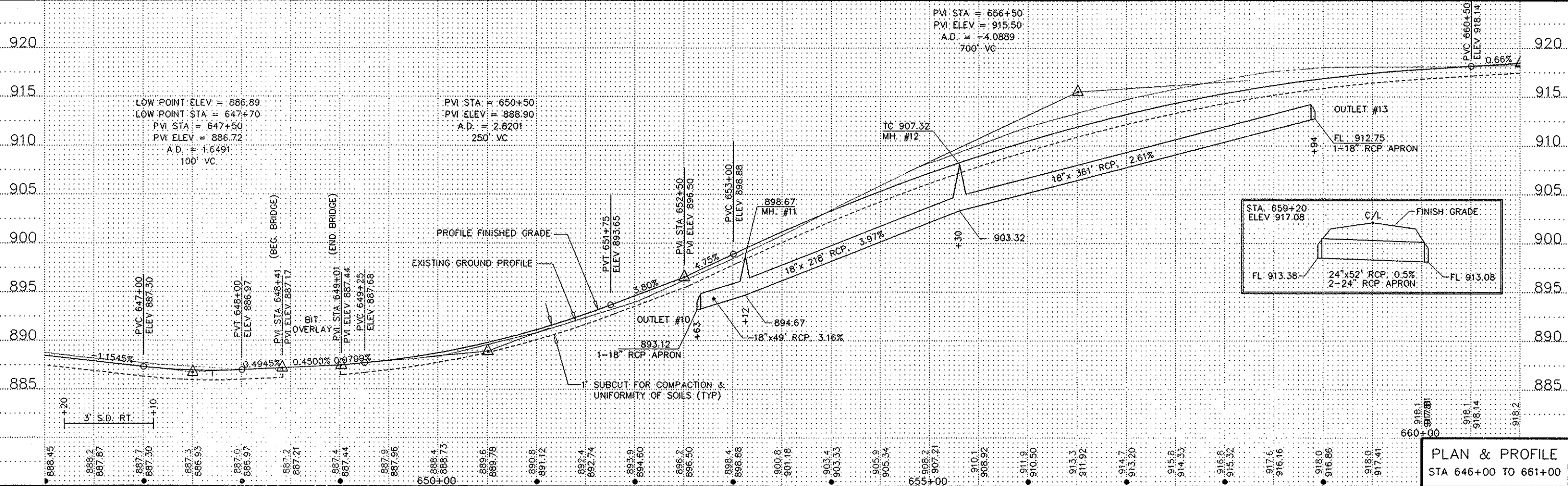
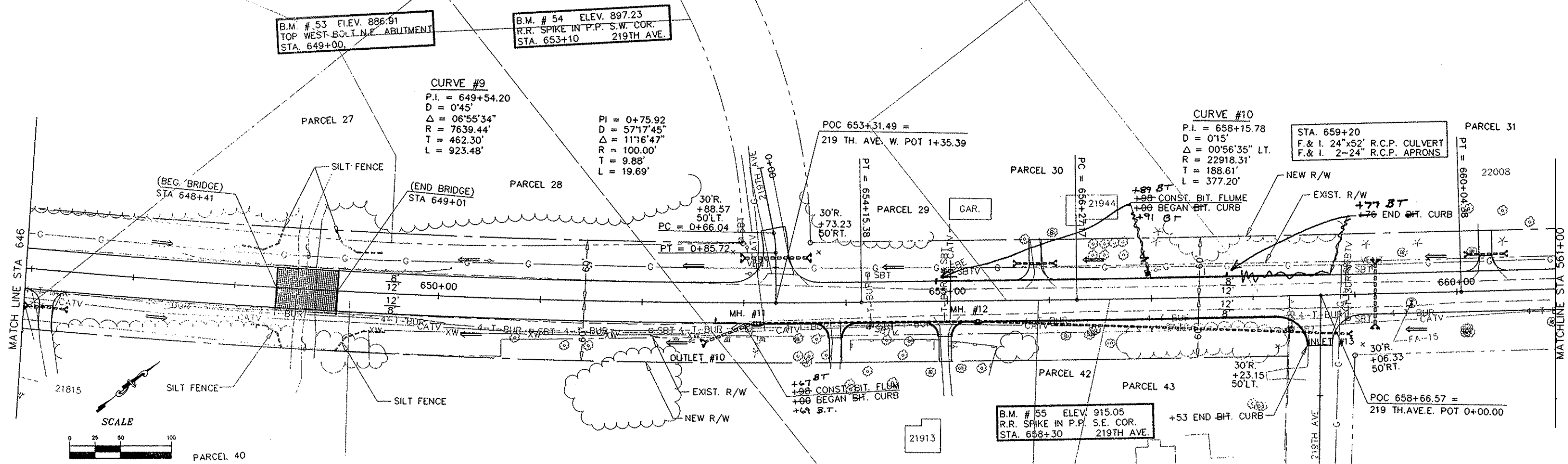

REVISIONS	DATE	BY

B.M. # 56 ELEV. 919.12'
R.R. SPIKE IN P.P.
STA. 667+50 60' LT.

CURVE #11
P.I. = 666+83.56
D = 3'30"00"
Δ = 36°02'21" LT.
R = 1637.02'
T = 532.52'
L = 1029.69'

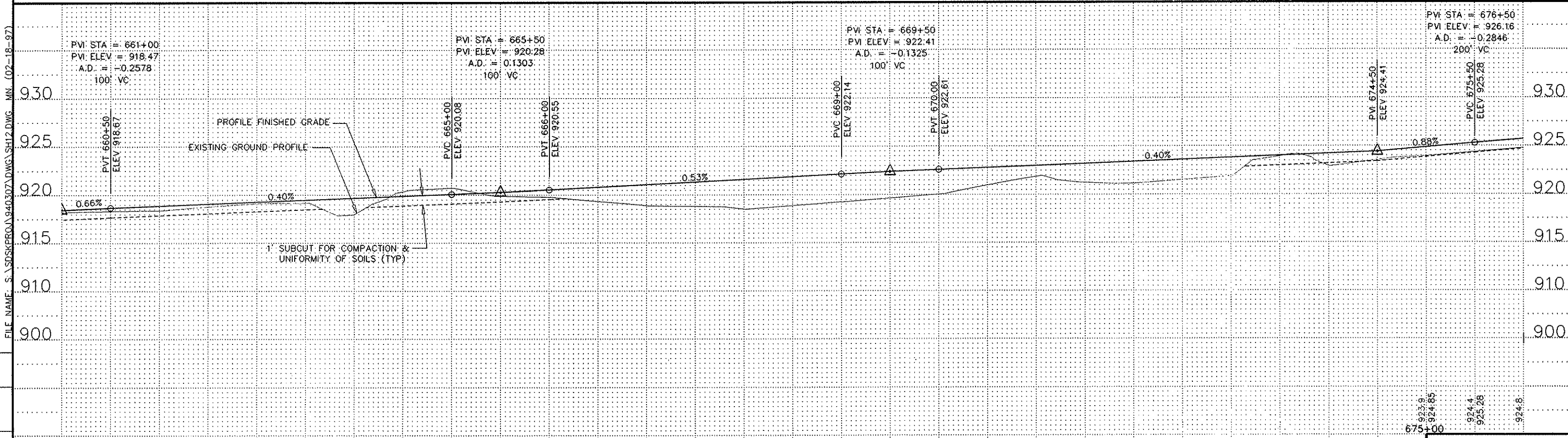
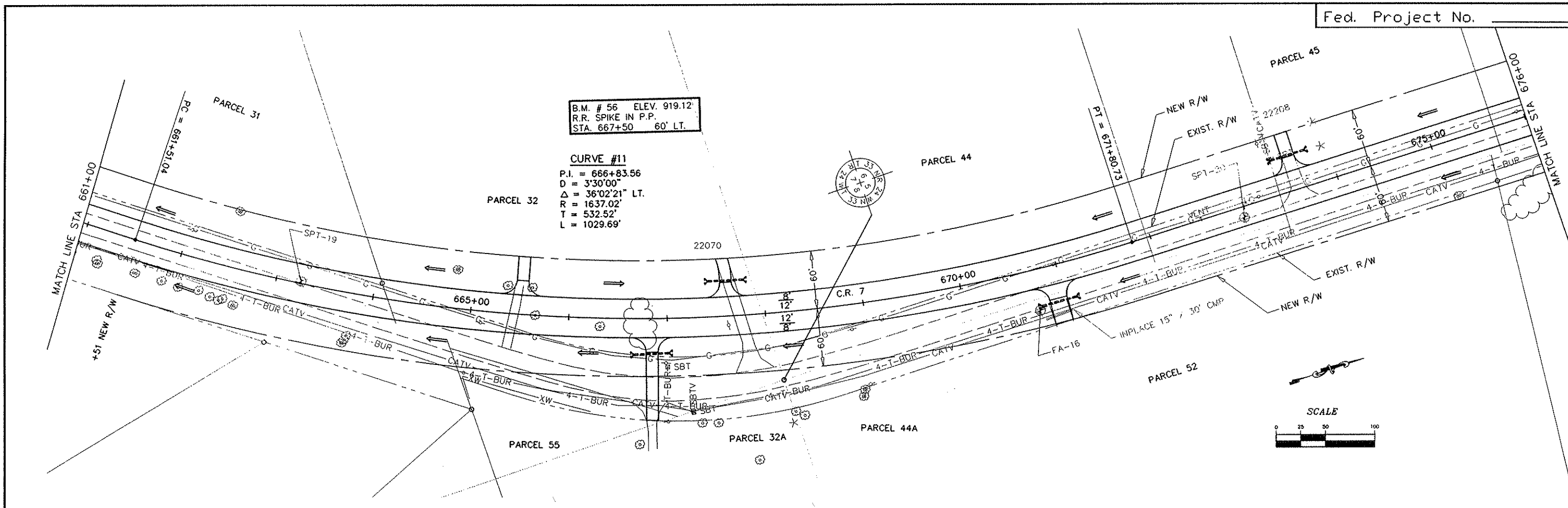

REVISIONS	DATE	BY

PLAN & PROFILE
STA 661+00 TO 676+00

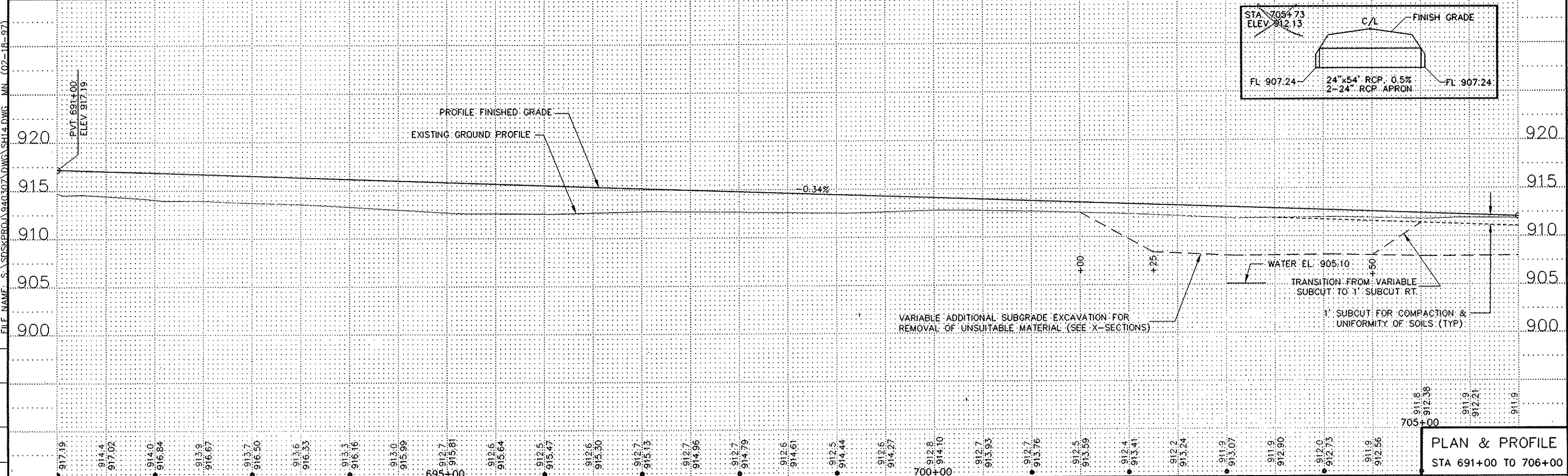
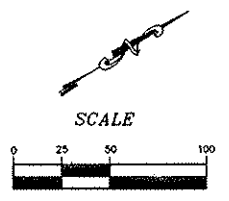
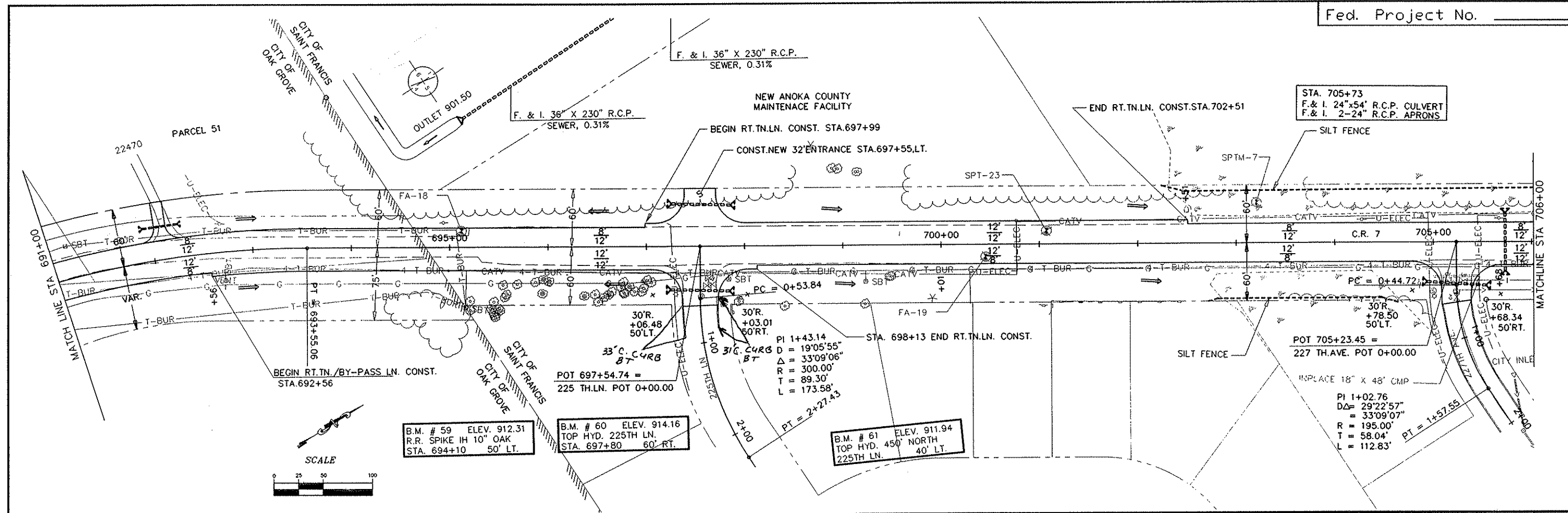

REVISIONS	DATE	BY

B.M. #62 ELEV. 914.89
 TOP HYD. 200' NO. 227TH LN.
 STA. 711+00 33' LT.

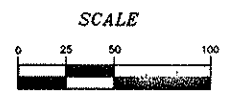
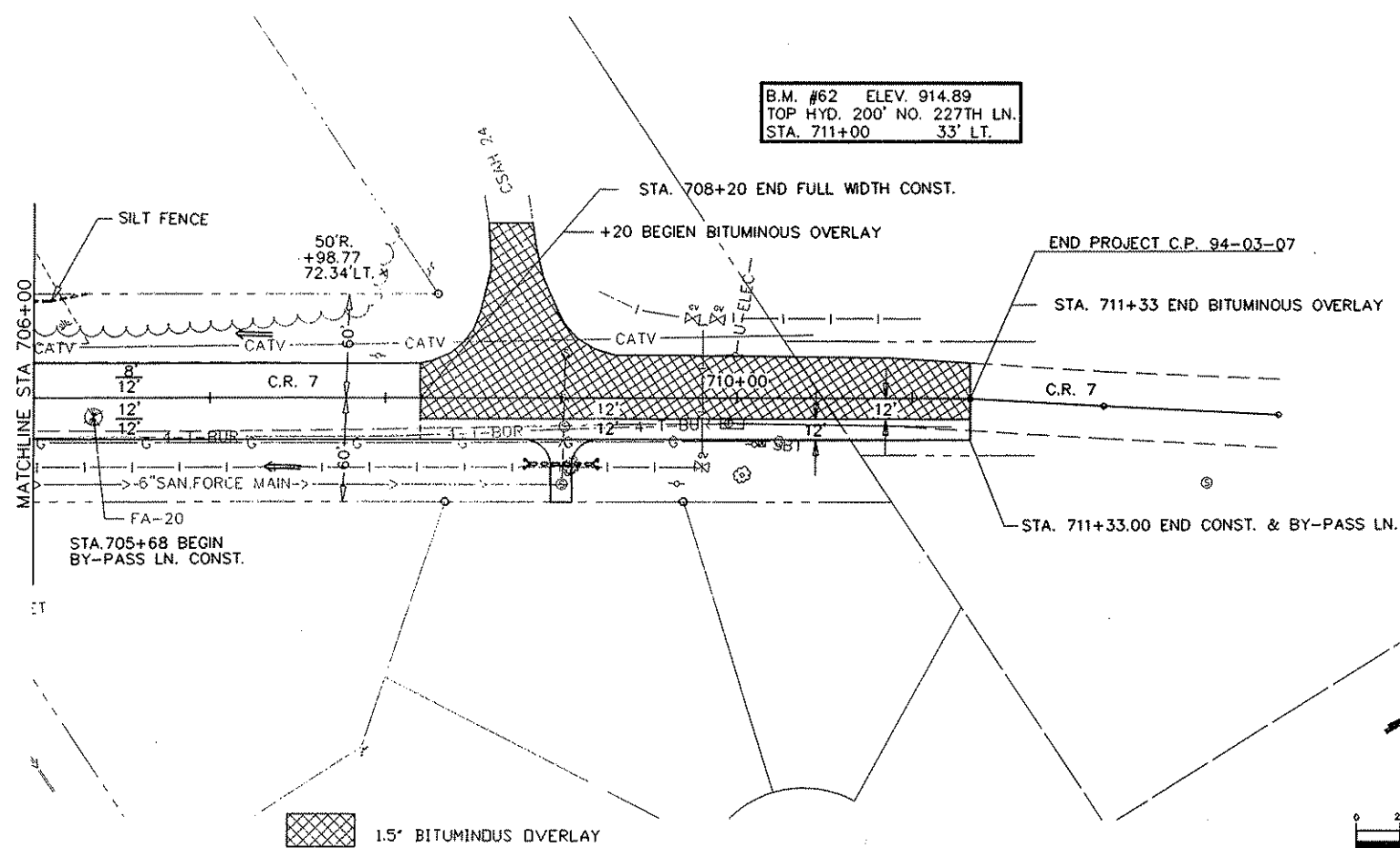

FILE NAME: S:\SDSK\PROJ\940307\DWG\SH15.DWG MN. (02-18-97)

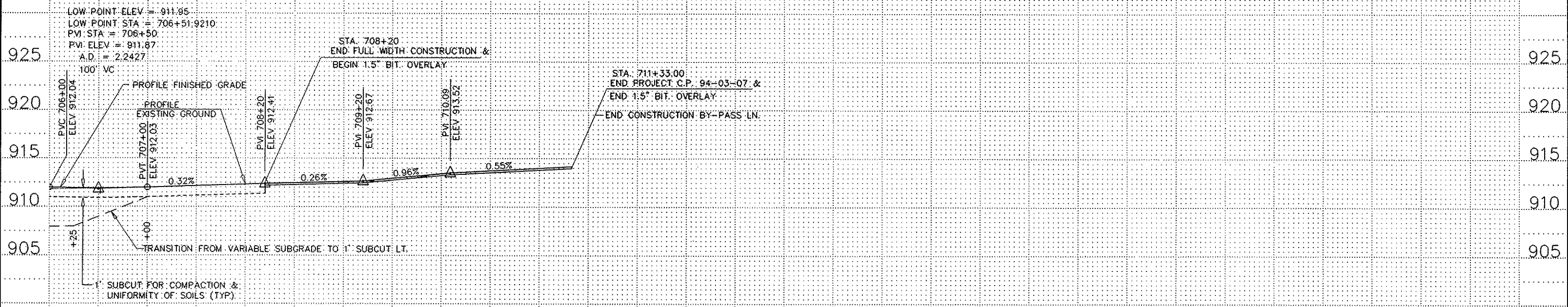

REVISIONS	DATE	BY

912.04	911.9	911.87	912.0	912.03	912.2	912.19	912.4	912.35	912.4	912.49	912.6	912.62	912.7	912.96	913.4	913.43	913.75	914.02
--------	-------	--------	-------	--------	-------	--------	-------	--------	-------	--------	-------	--------	-------	--------	-------	--------	--------	--------

PLAN & PROFILE
 STA 706+00 TO 710+95

EXCAVATION EMBANKMENT
SUB-TOTALS CU.YDS. SUB-TOTALS CU.YDS.

EXCAVATION EMBANKMENT
SUB-TOTALS CU.YDS. SUB-TOTALS CU.YDS.

REG
SUB
TOPSOIL

REG
SUB
TOPSOIL

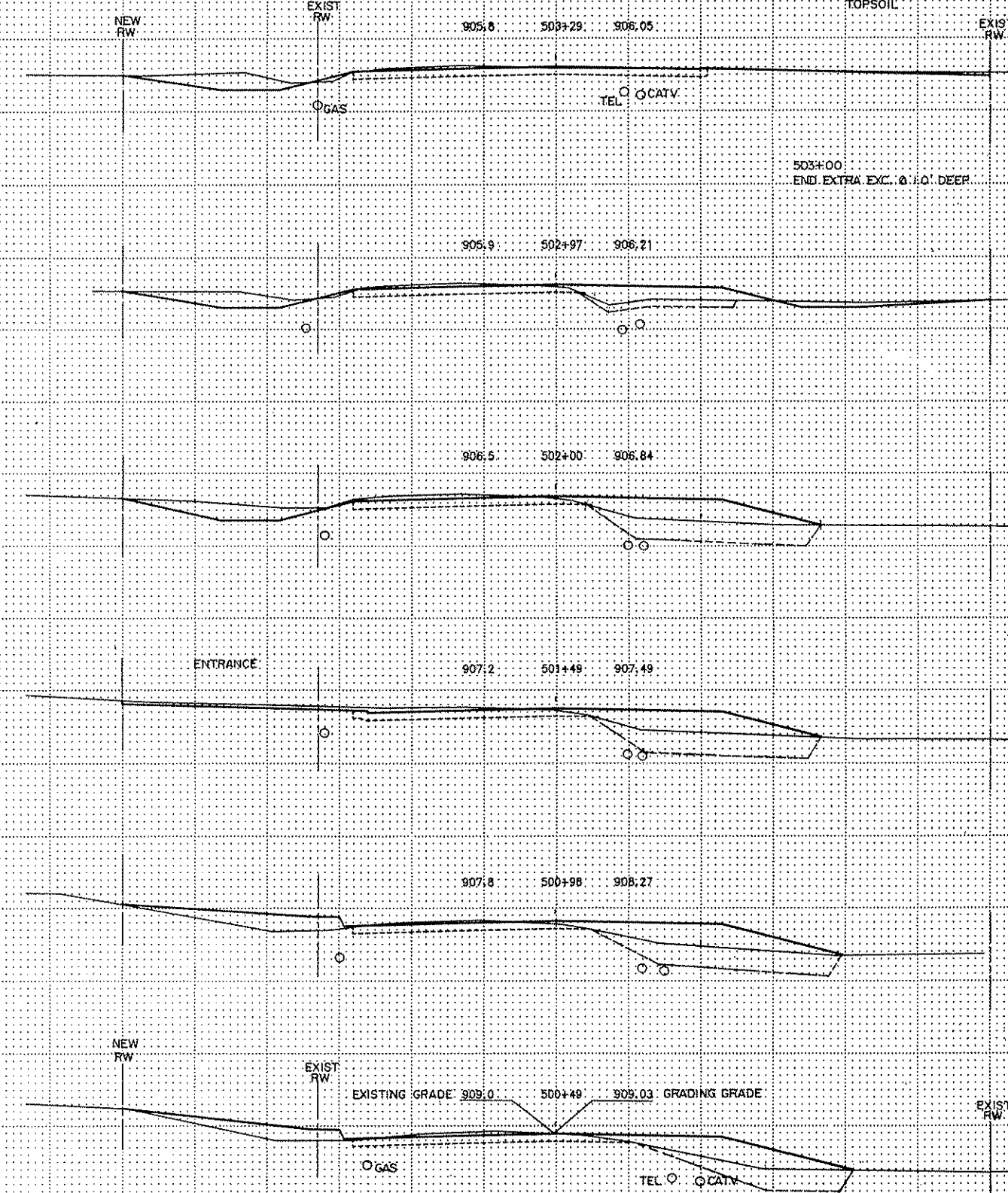
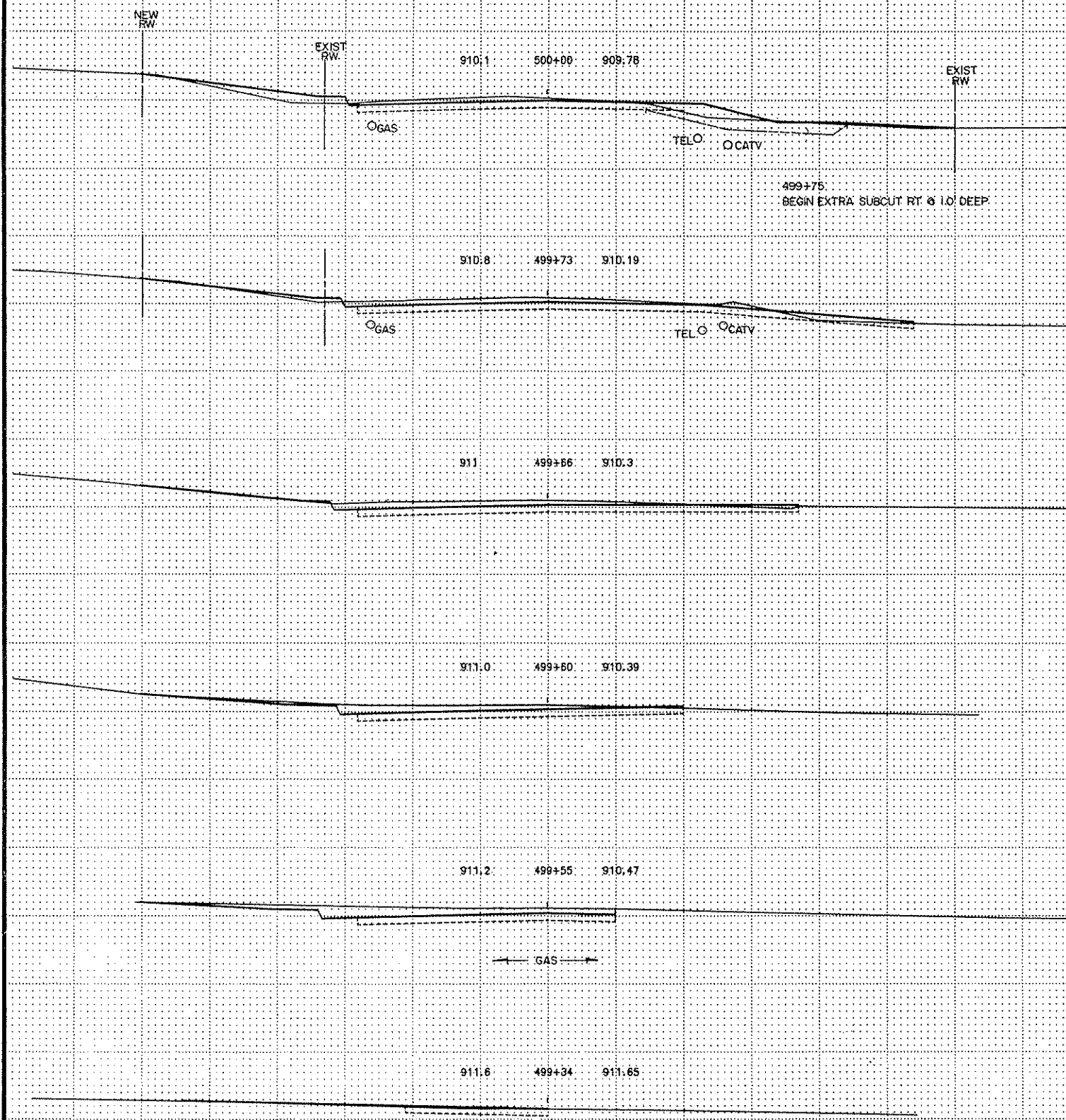

NOTE: UTILITY ELEVATIONS ASSUMED.
NOT ACTUAL

CROSS-SECTIONS

STA. 499+34 TO STA. 503+29

EXCAVATION EMBANKMENT
SUB-TOTALS CU.YDS. SUB-TOTALS CU.YDS.

EXCAVATION EMBANKMENT
SUB-TOTALS CU.YDS. SUB-TOTALS CU.YDS.

REG
SUB
TOPSOIL

REG
SUB
TOPSOIL

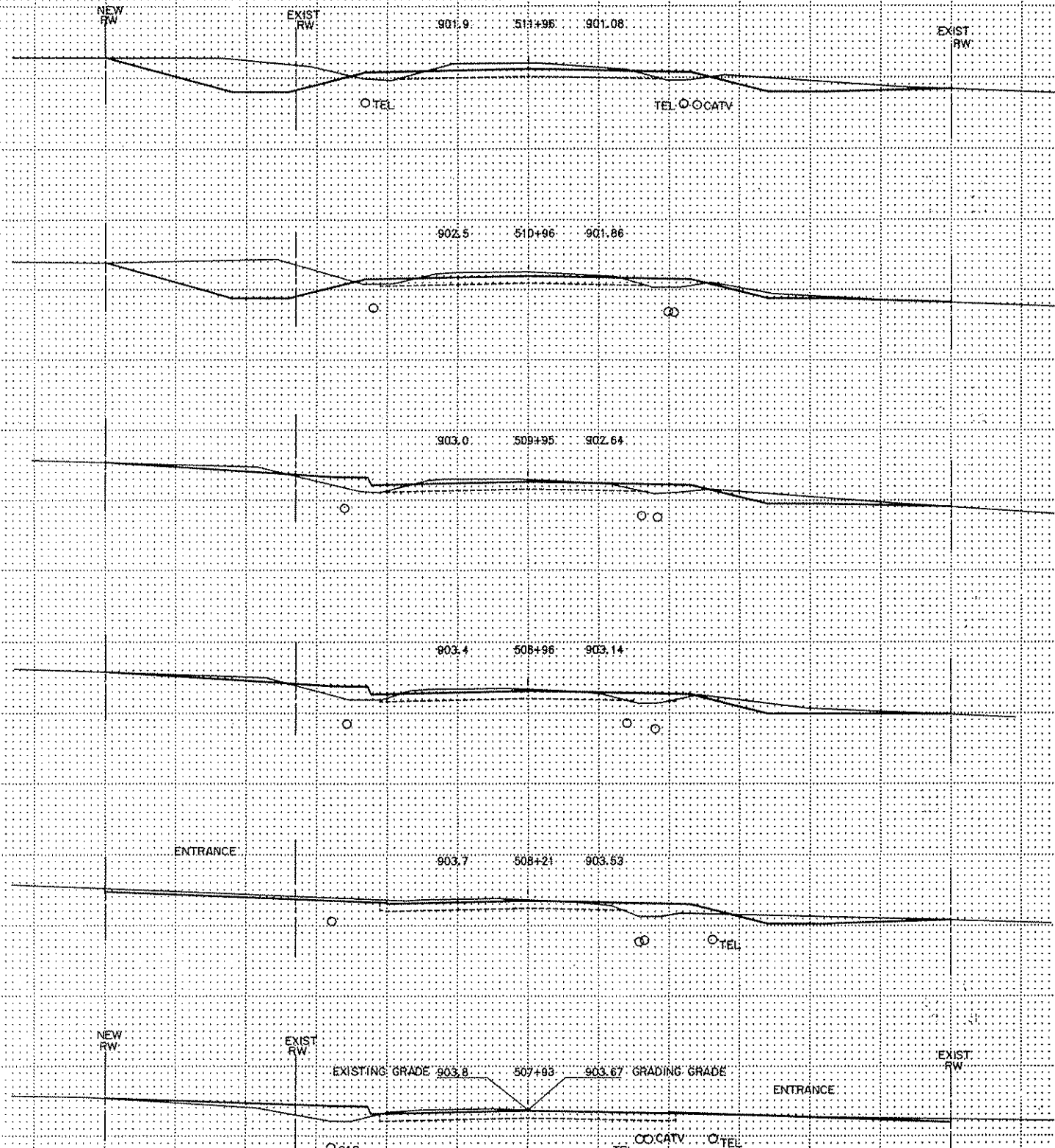
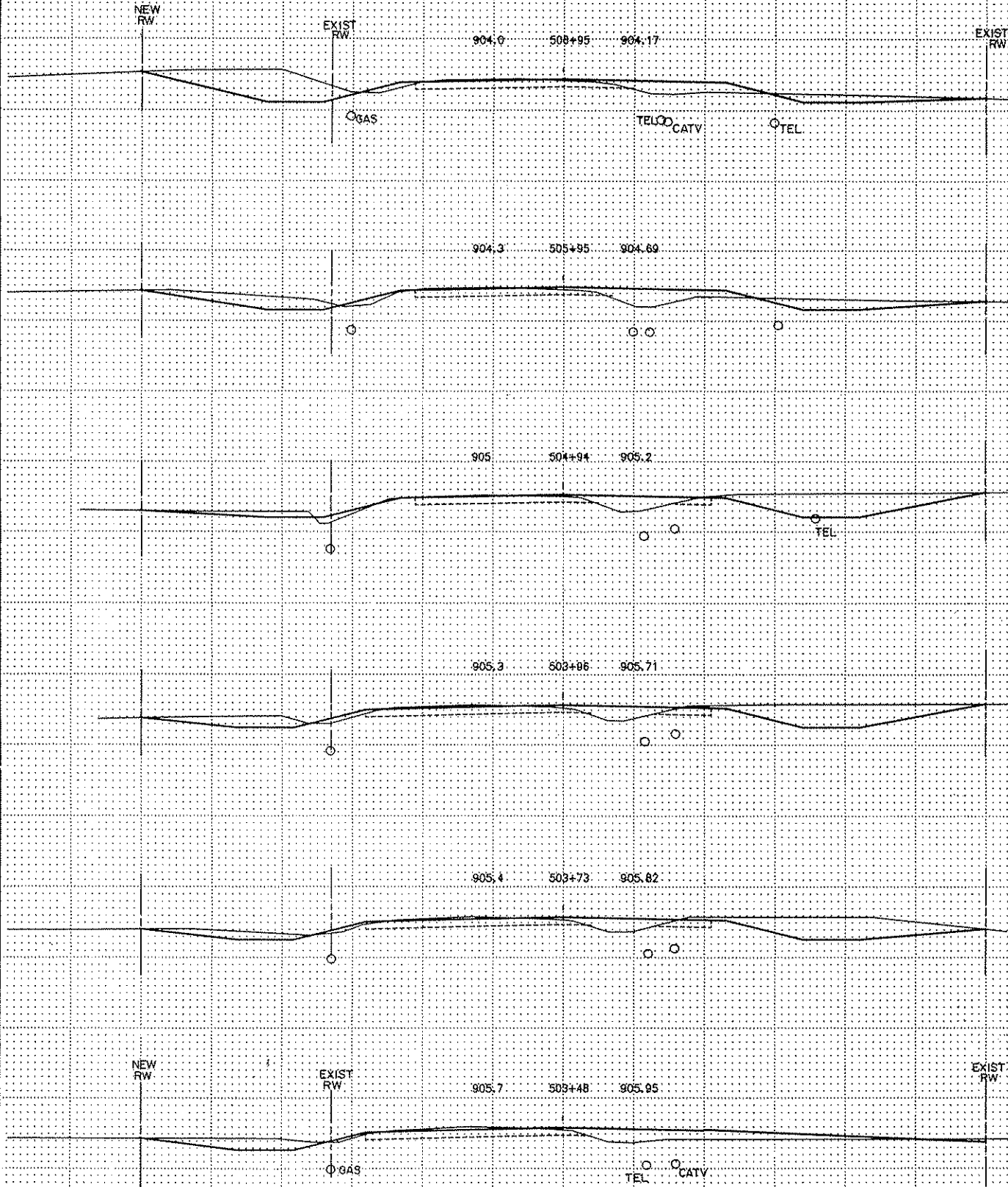

NOTE: UTILITY ELEVATIONS ASSUMED
NOT ACTUAL

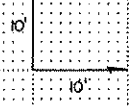

CROSS-SECTIONS
STA 503+48 TO STA 511+96

PLATE 3 Full Cross Section DOT-ED blueprint. Order Form MAB Plate 3DY

EXCAVATION EMBANKMENT
SUB-TOTALS CU.YDS. SUB-TOTALS CU.YDS.

EXCAVATION EMBANKMENT
SUB-TOTALS CU.YDS. SUB-TOTALS CU.YDS.

REG
SUB
TOPSOIL

REG
SUB
TOPSOIL

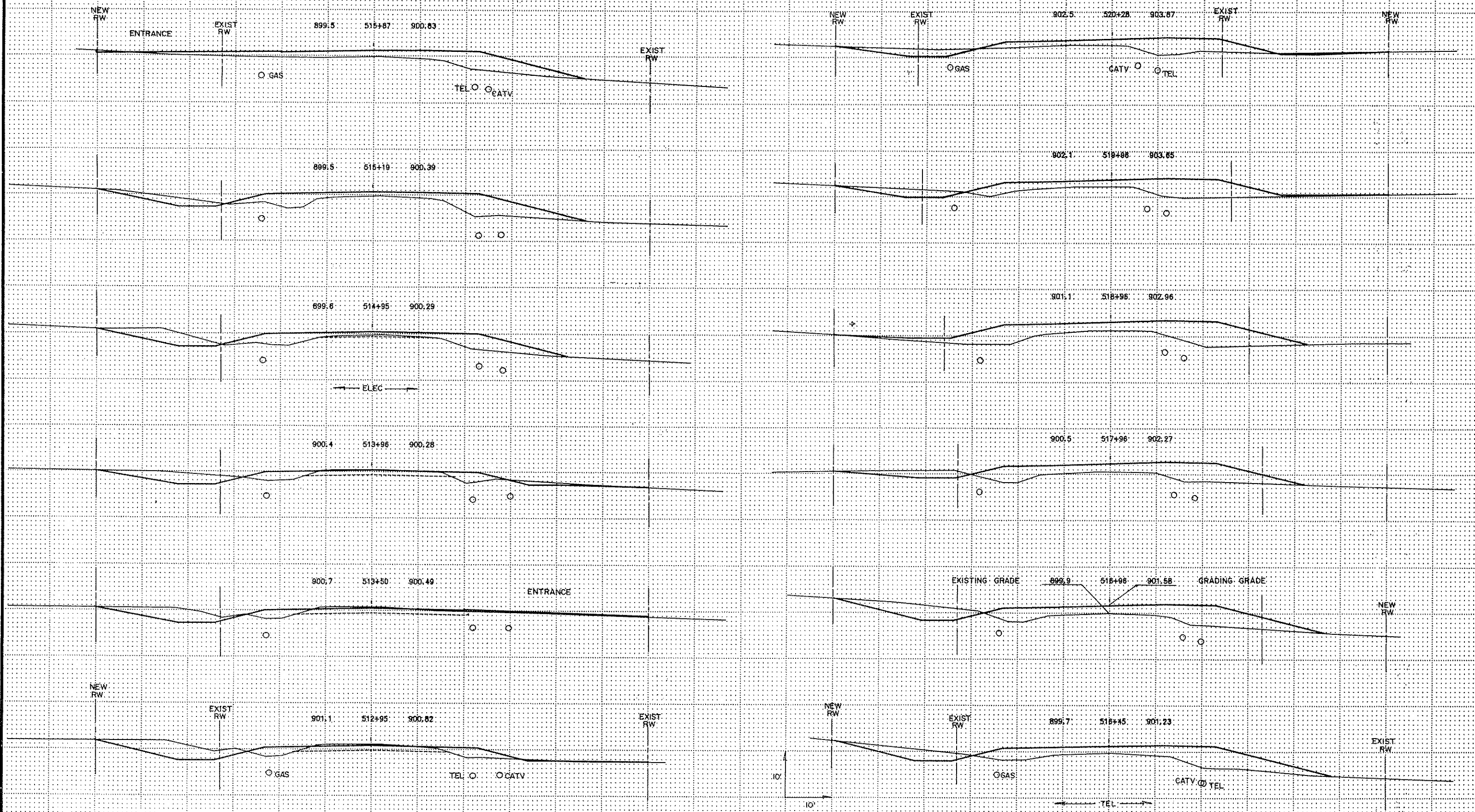

NOTE: UTILITY ELEVATIONS ASSUMED.
NOT ACTUAL

CROSS-SECTIONS
STA. 512+95 TO STA. 520+28

PLATE 3 Full Cross Section DOTTED blueprint Civil Form M&B Plate 3DV

EXCAVATION EMBANKMENT
SUB-TOTALS CU.YDS. SUB-TOTALS CU.YDS.

EXCAVATION EMBANKMENT
SUB-TOTALS CU.YDS. SUB-TOTALS CU.YDS.

REG.
SUB.
TOPSOIL

REG.
SUB.
TOPSOIL

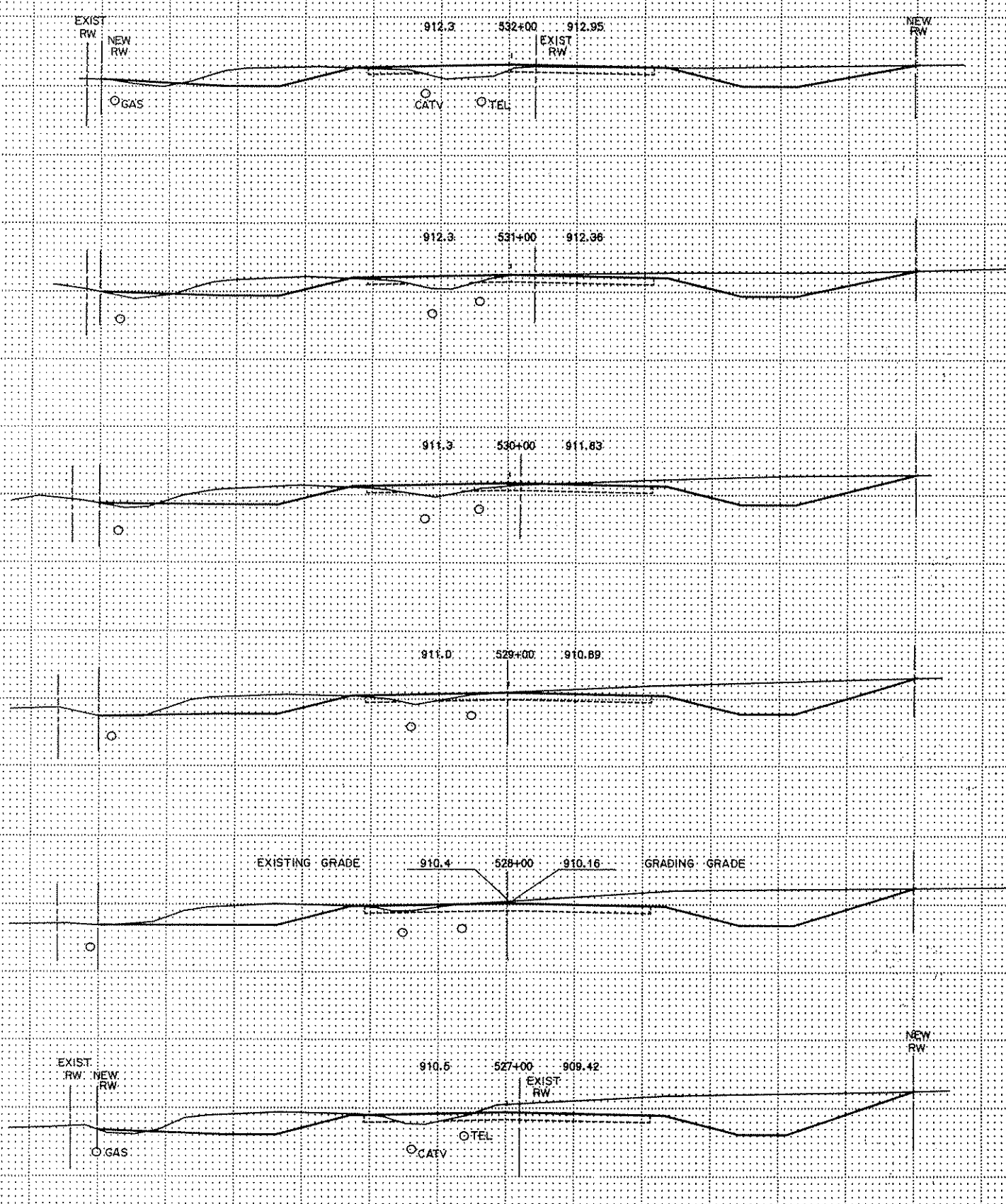
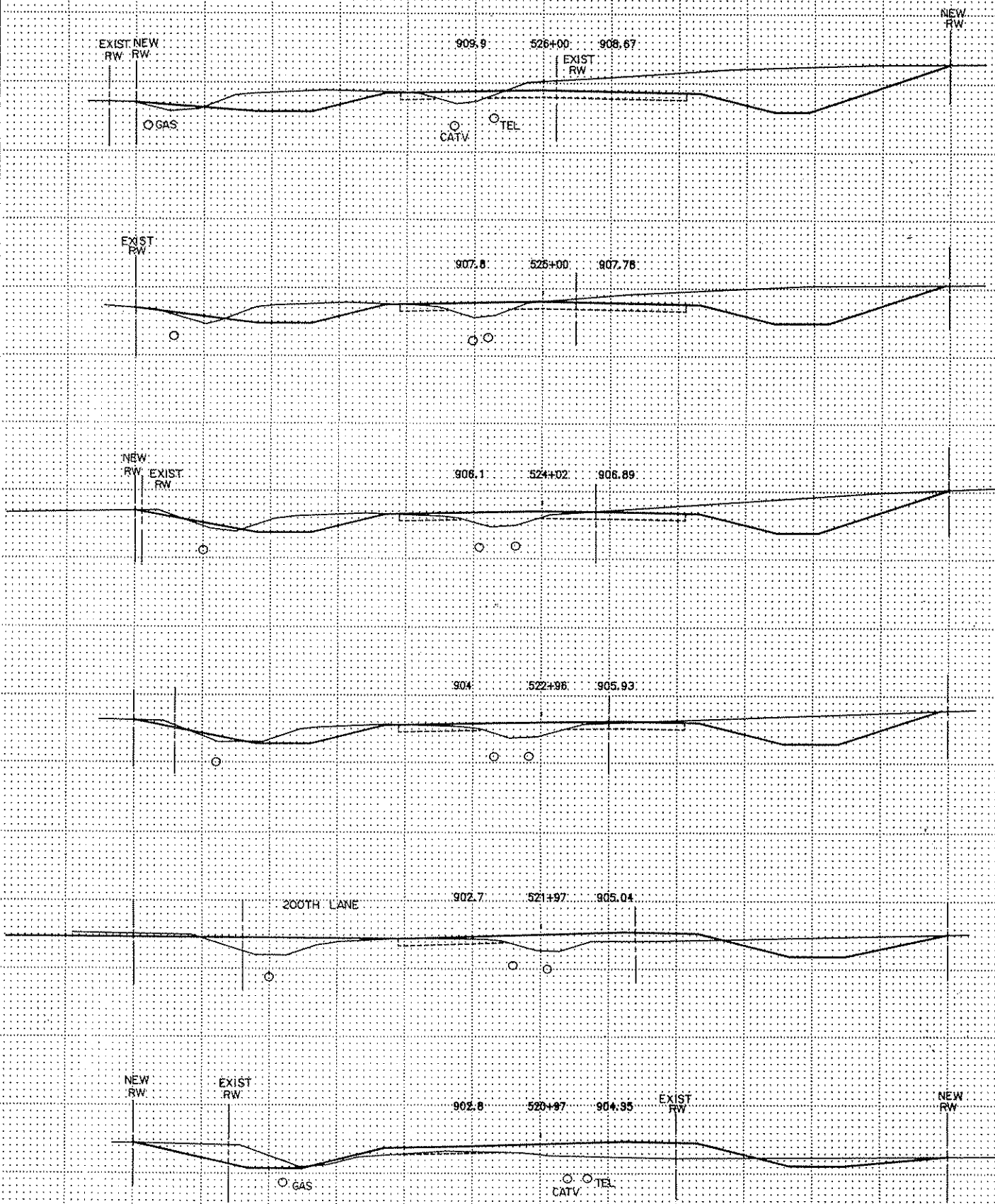

NOTE: UTILITY ELEVATIONS ASSUMED
NOT ACTUAL

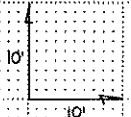

CROSS-SECTIONS
STA. 520+97 TO STA. 532+00

PLATE 3 For Cross Section: DOTTED blueprint. Clear Form: M&B Page 3DV

EXCAVATION SUB-TOTALS CU.YDS. EMBANKMENT SUB-TOTALS CU.YDS.

EXCAVATION SUB-TOTALS CU.YDS. EMBANKMENT SUB-TOTALS CU.YDS.

REG. SUB-TOPSOIL.

REG. SUB-TOPSOIL.

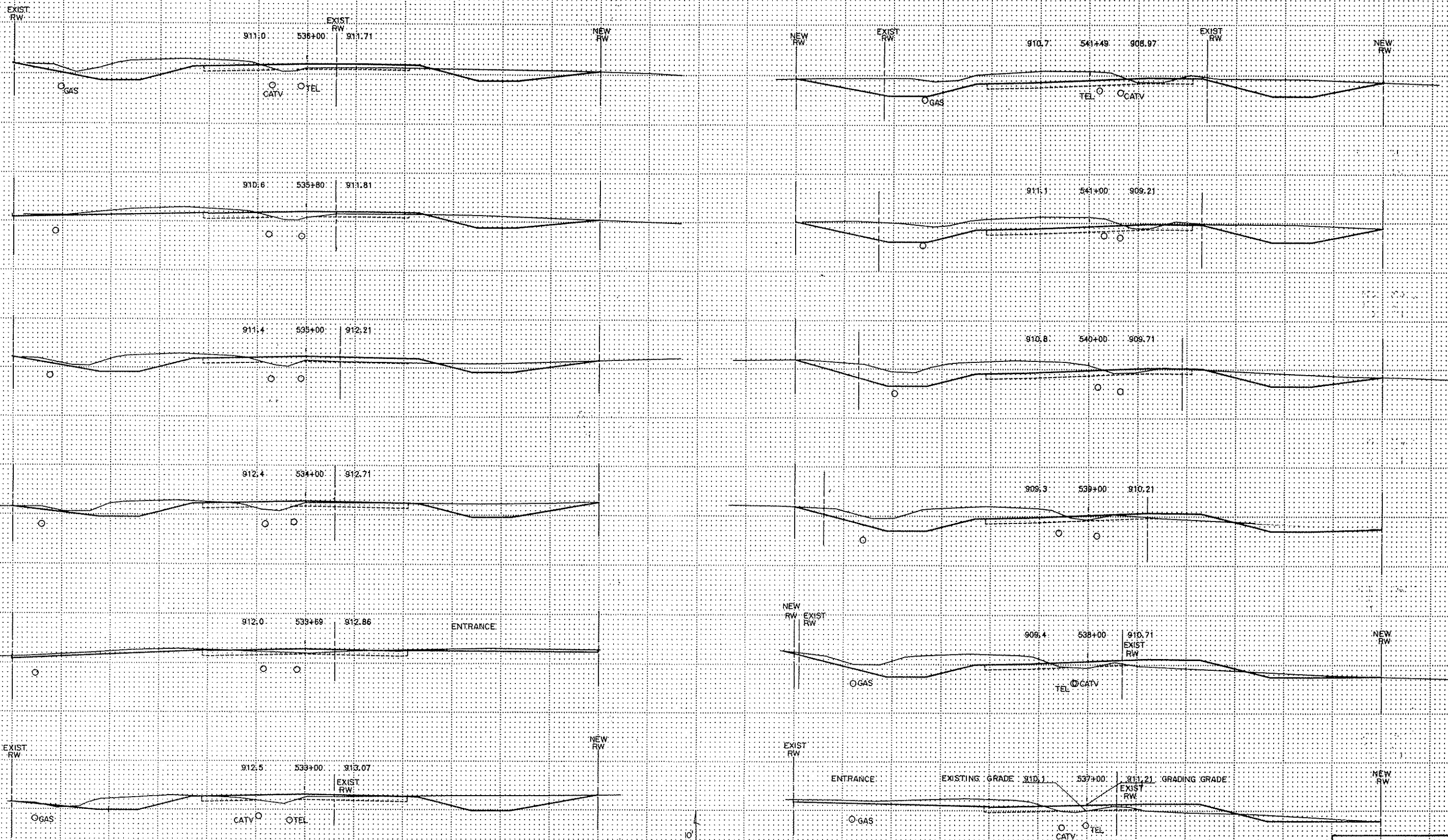

NOTE: UTILITY ELEVATIONS ASSUMED NOT ACTUAL.

CROSS-SECTIONS
STA. 533+00 TO STA. 541+49

PLATE 3 Full Cross Section DOTTED blueprint Order Form # WMB Plate 3D

EXCAVATION EMBANKMENT
 SUB-TOTALS CU.YDS. SUB-TOTALS CU.YDS.

EXCAVATION EMBANKMENT
 SUB-TOTALS CU.YDS. SUB-TOTALS CU.YDS.

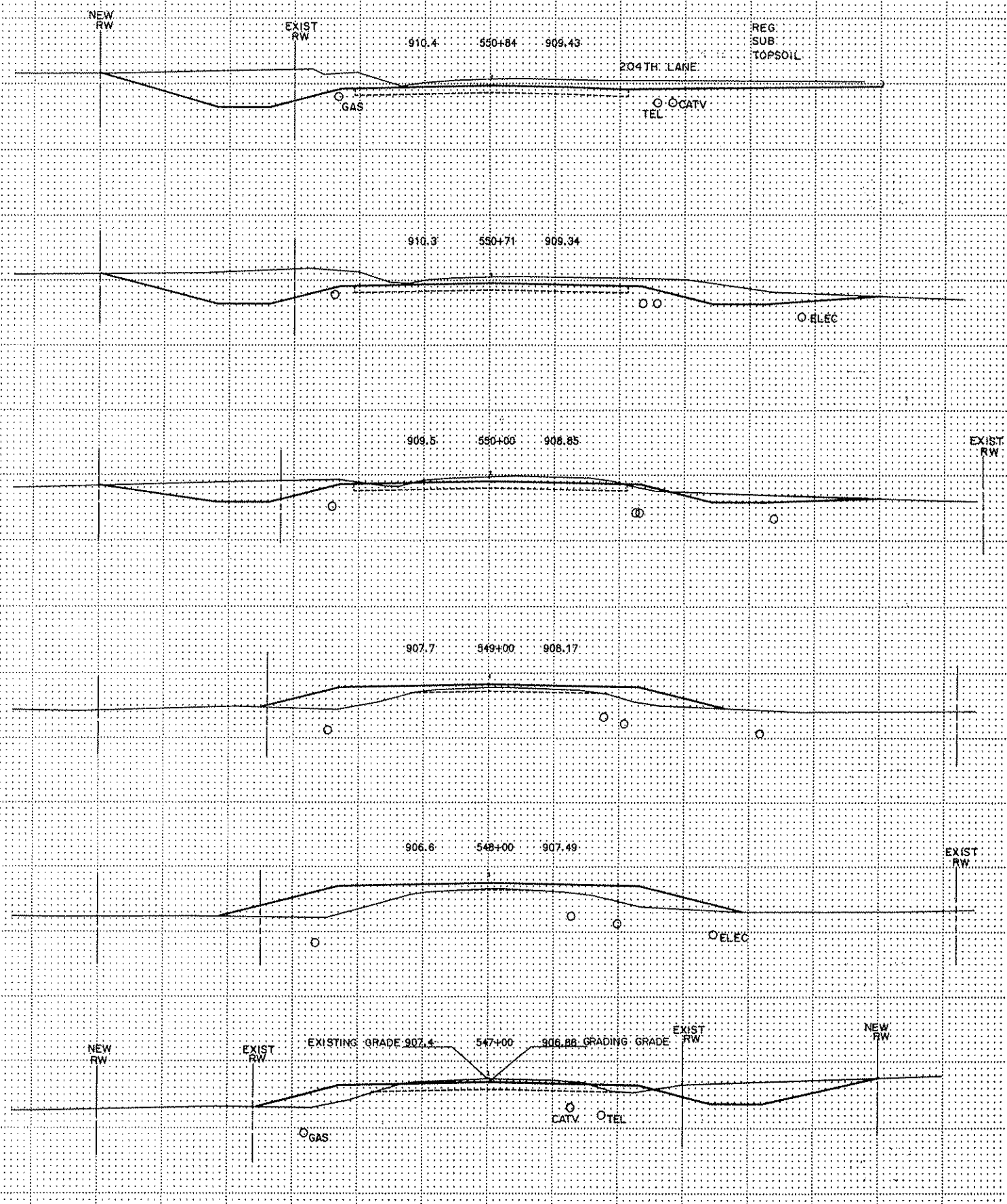
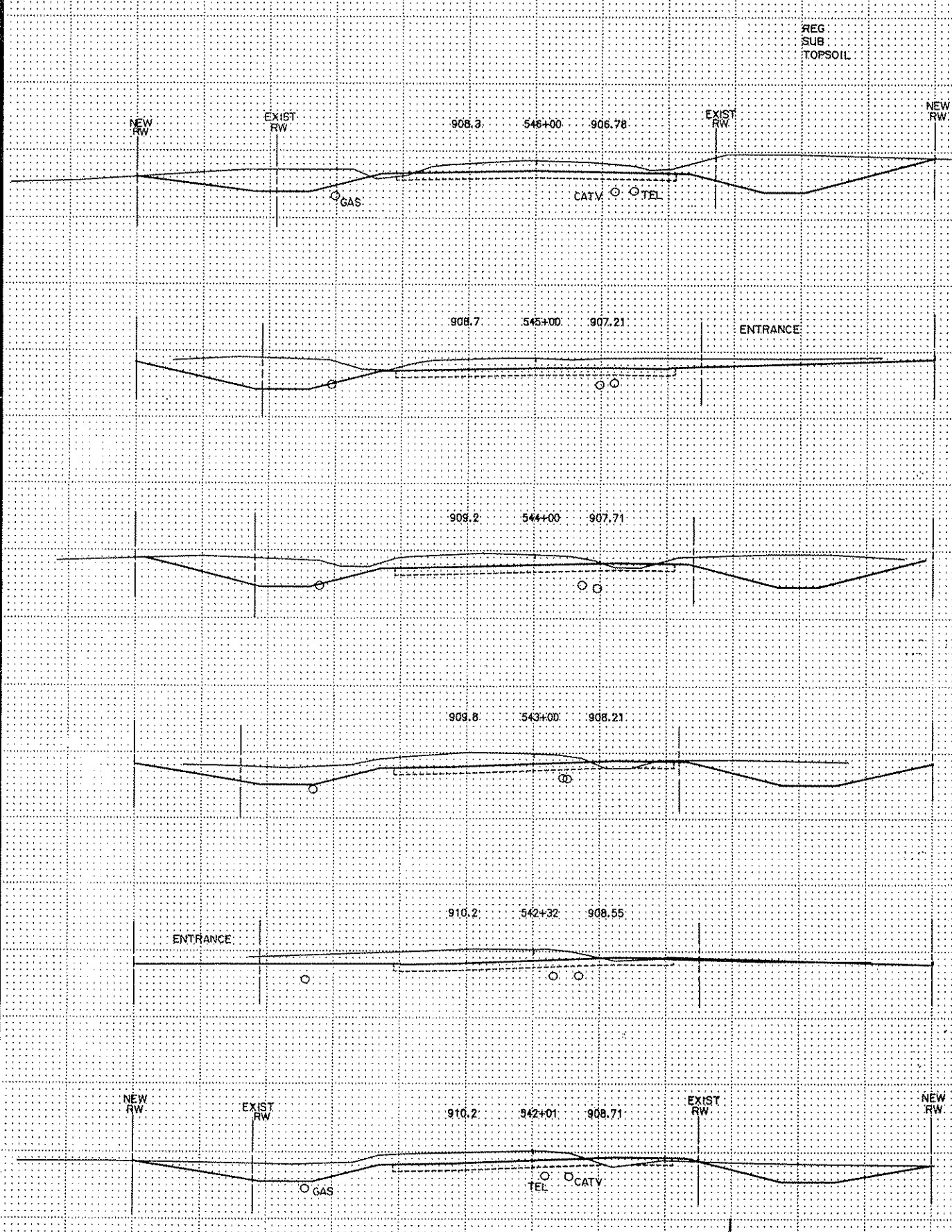

NOTE: UTILITY ELEVATIONS ASSUMED
 NOT ACTUAL

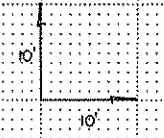

CROSS-SECTIONS
 STA. 542+01 TO STA. 550+84

PLATE 3 Full Cross Section DOTTED blueprint Order Form VMB Plate 3DY

EXCAVATION EMBANKMENT
 SUB-TOTALS CU.YDS. SUB-TOTALS CU.YDS.

EXCAVATION EMBANKMENT
 SUB-TOTALS CU.YDS. SUB-TOTALS CU.YDS.

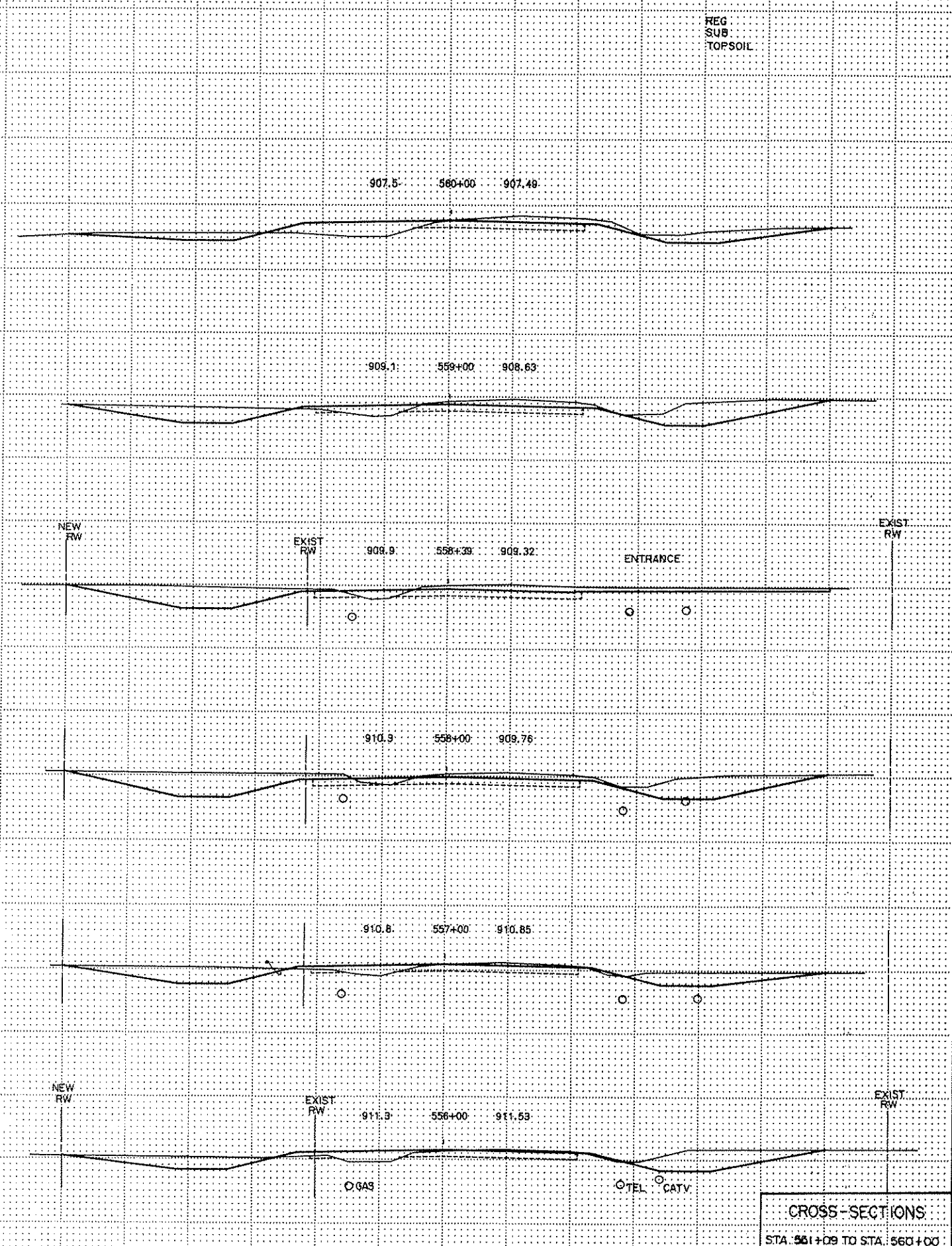
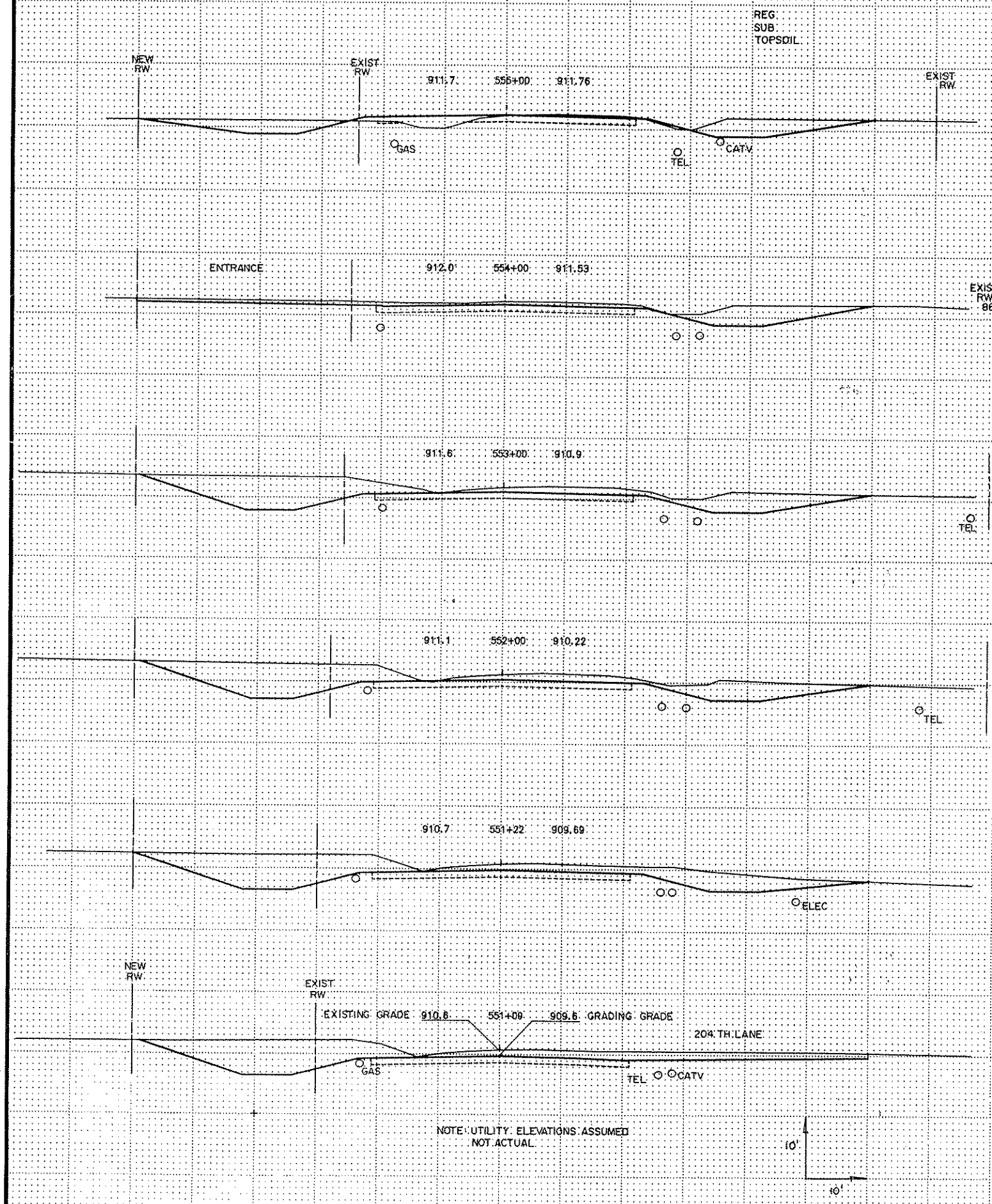

CROSS-SECTIONS
 STA. 561+09 TO STA. 560+00

DATE 3 File Cross Section 10/11/07 Order Form 1/10/07 Page 30V

EXCAVATION EMBANKMENT
SUB-TOTALS CU.YDS. SUB-TOTALS CU.YDS.

EXCAVATION EMBANKMENT
SUB-TOTALS CU.YDS. SUB-TOTALS CU.YDS.

REG
SUB
TOPSOIL

REG
SUB
TOPSOIL

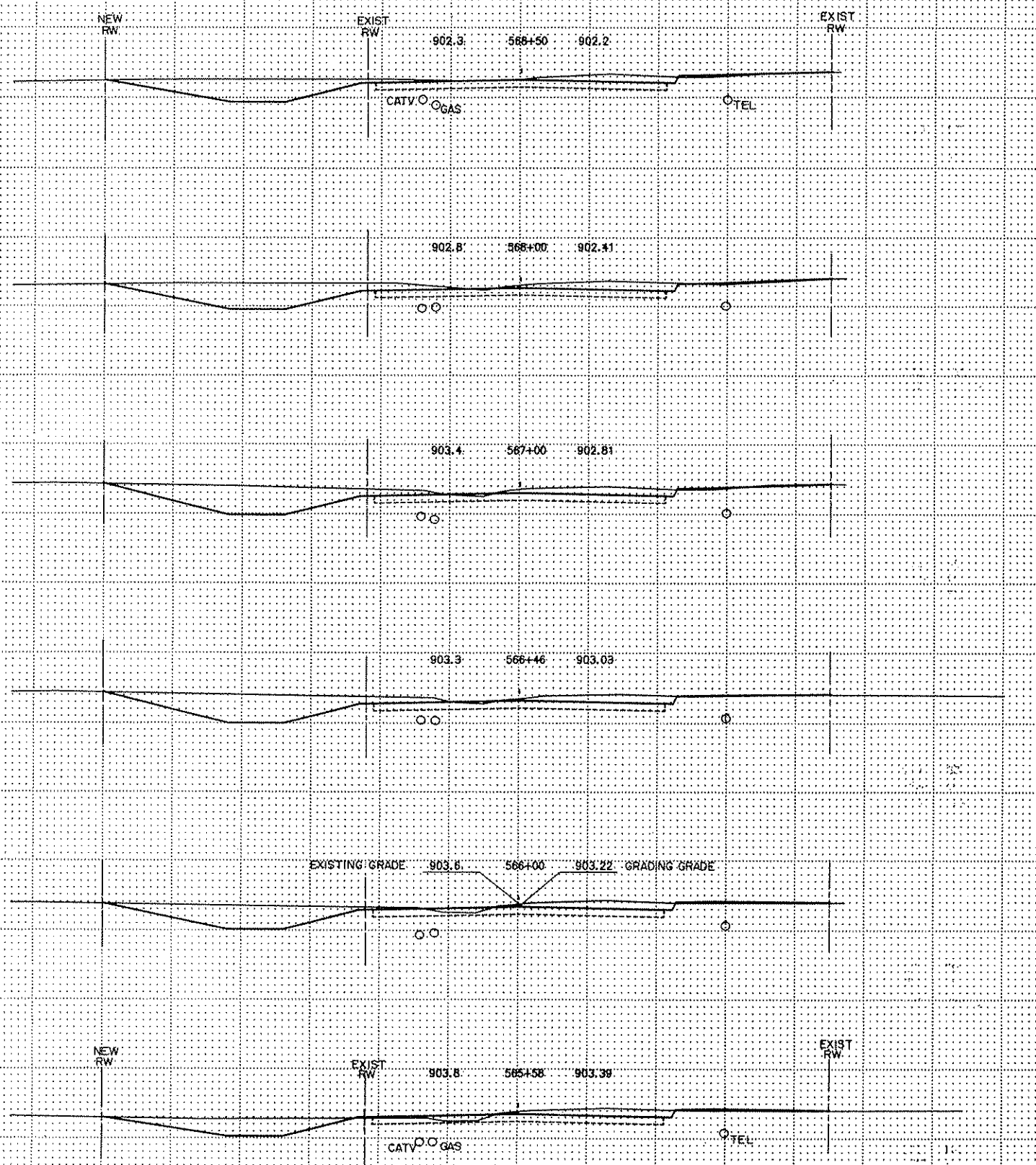
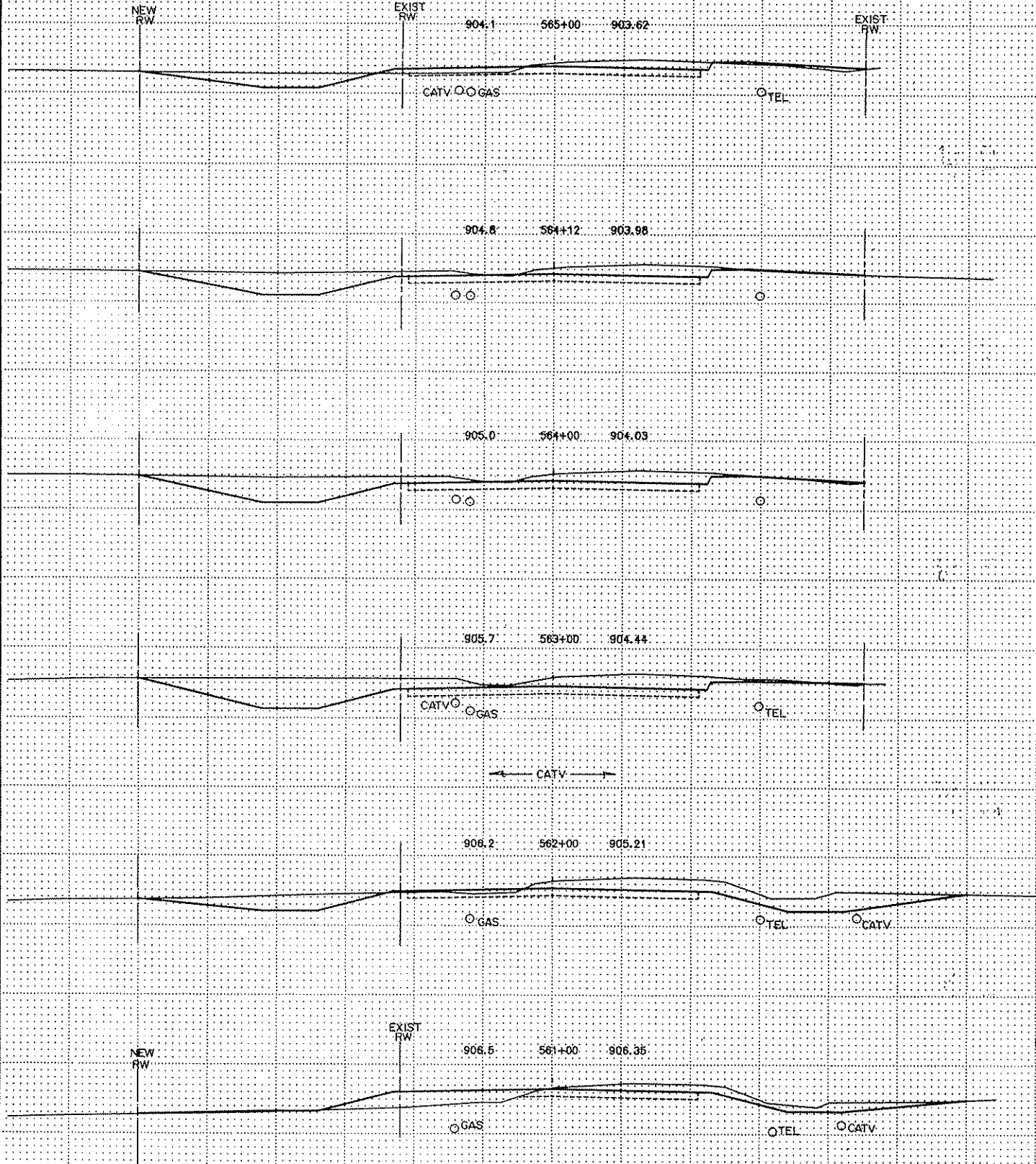

NOTE: UTILITY ELEVATIONS ASSUMED
NOT ACTUAL

10'

PLATE 3 Full Cross Section COTTED blueprint Clear Form MVB Plate 3DV

CROSS-SECTIONS
STA. 561+00 TO STA. 566+50

EXCAVATION EMBANKMENT
 SUB-TOTALS CU.YDS. SUB-TOTALS CU.YDS.

EXCAVATION EMBANKMENT
 SUB-TOTALS CU.YDS. SUB-TOTALS CU.YDS.

REG
 SUB
 TOPSOIL

REG
 SUB
 TOPSOIL

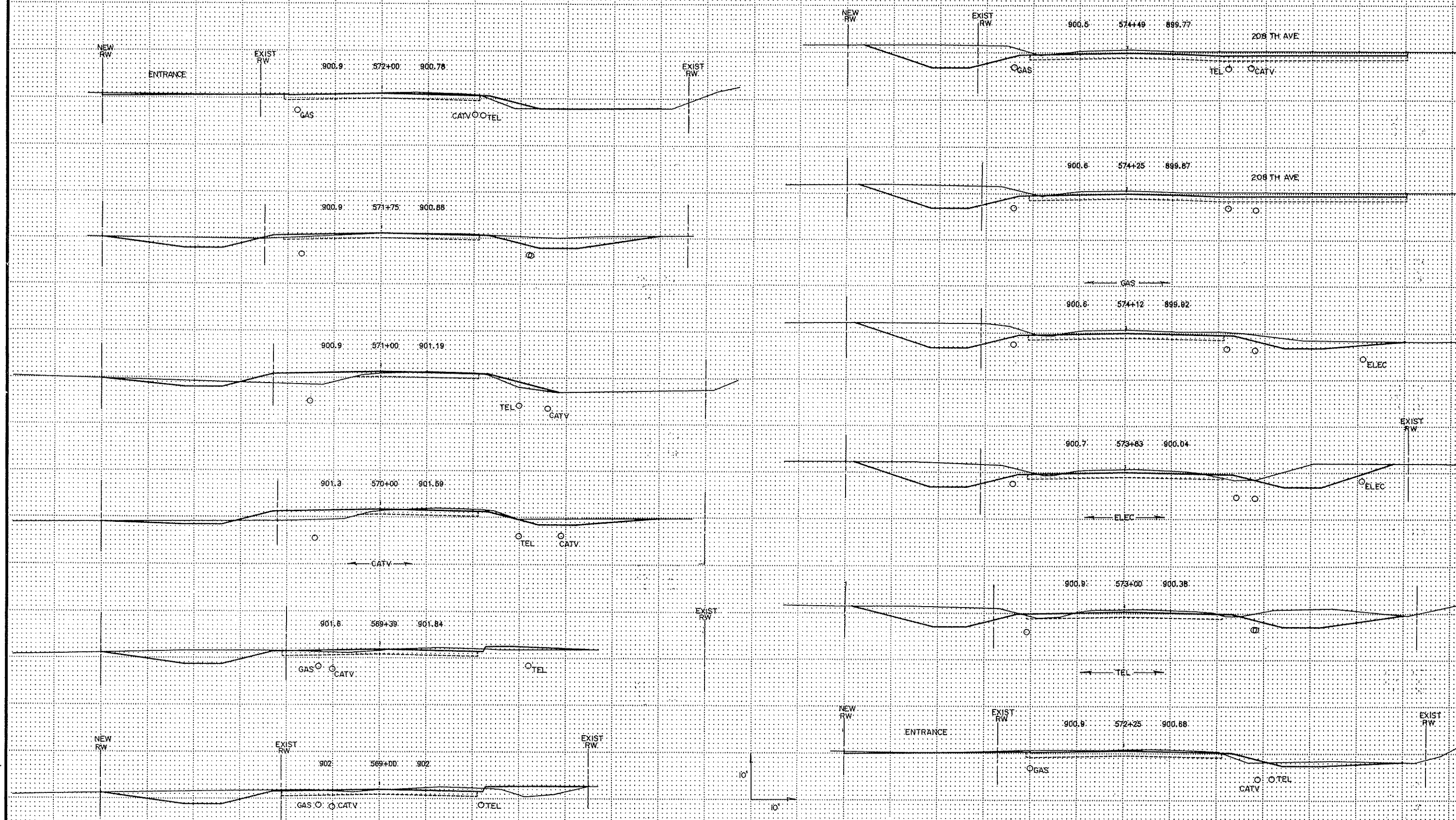

NOTE: UTILITY ELEVATIONS ASSUMED
 NOT ACTUAL

CROSS-SECTIONS

STA. 569+00 TO STA. 574+49

PLATE 3 Full Cross Section DOTTED blueprint. Order Form M&B Plate 3D3

EXCAVATION EMBANKMENT
SUB-TOTALS CU.YDS. SUB-TOTALS CU.YDS.

EXCAVATION EMBANKMENT
SUB-TOTALS CU.YDS. SUB-TOTALS CU.YDS.

REG
SUB
TOPSOIL

REG
SUB
TOPSOIL

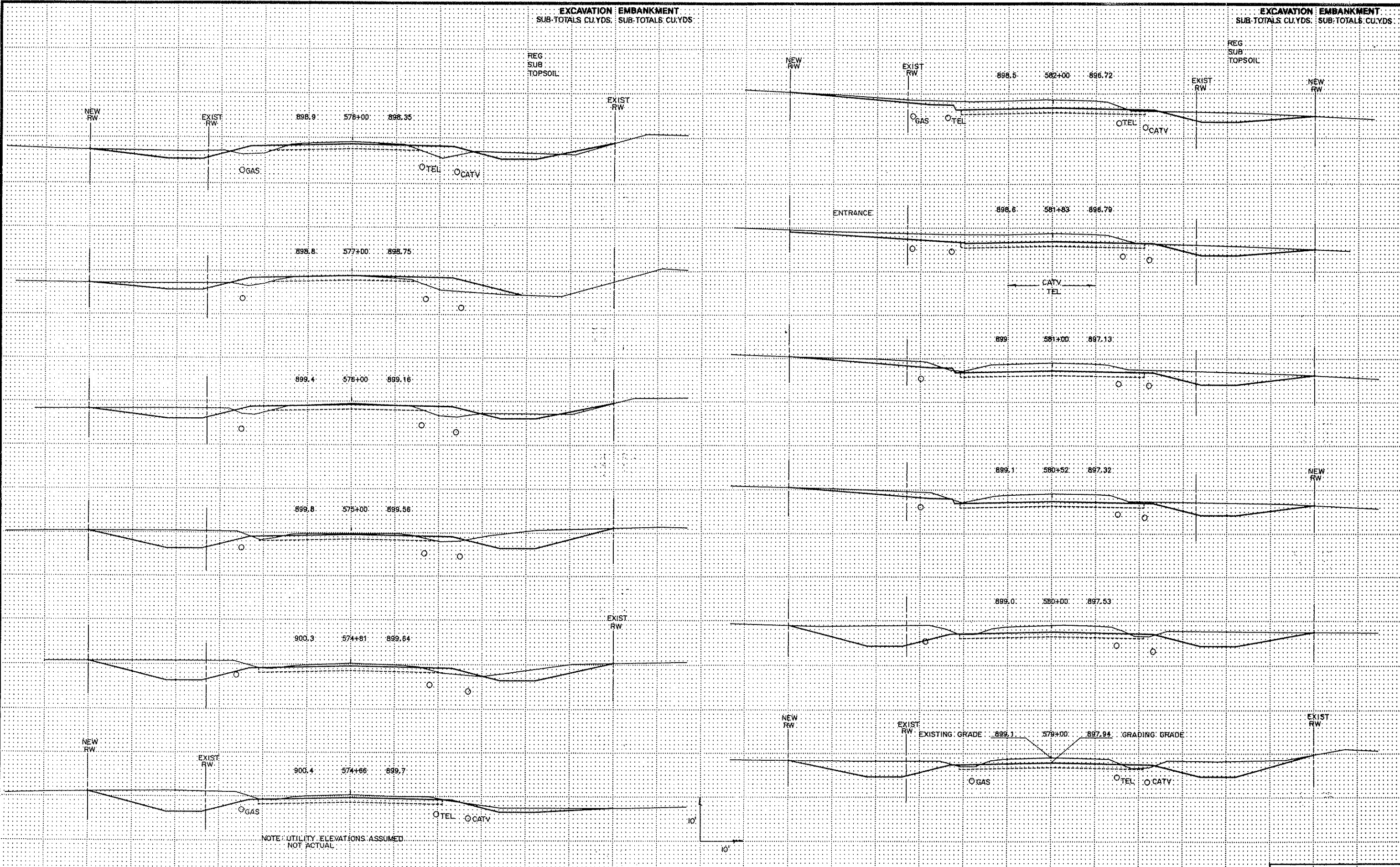

NOTE: UTILITY ELEVATIONS ASSUMED
NOT ACTUAL

10'
10'

CROSS-SECTIONS
STA. 574+66 TO STA. 582+00

PLATE 3 For Cross Section DOTTED Client Form # WMB Plate 3D1

EXCAVATION EMBANKMENT
SUB-TOTALS CU.YDS. SUB-TOTALS CU.YDS.

EXCAVATION EMBANKMENT
SUB-TOTALS CU.YDS. SUB-TOTALS CU.YDS.

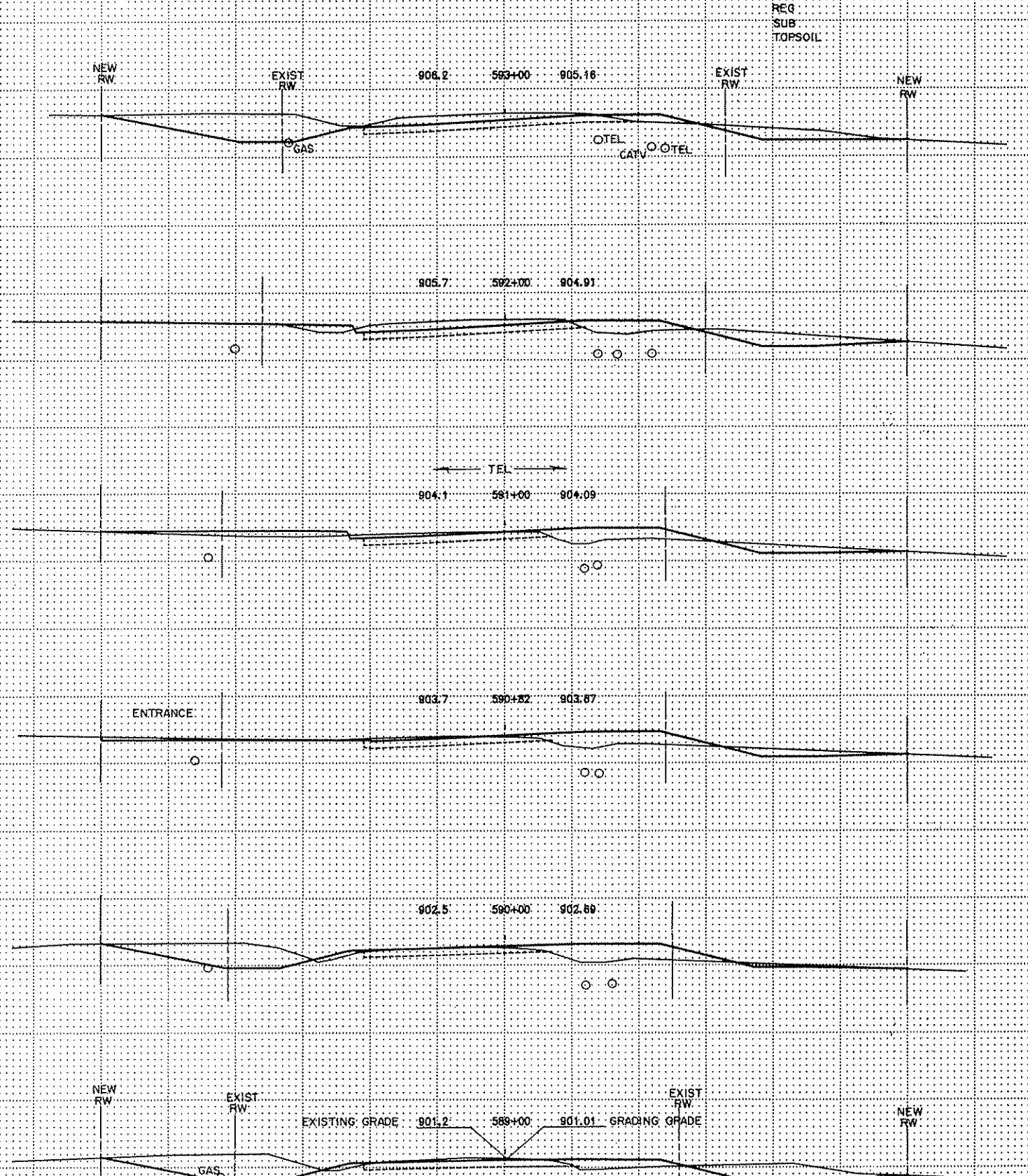
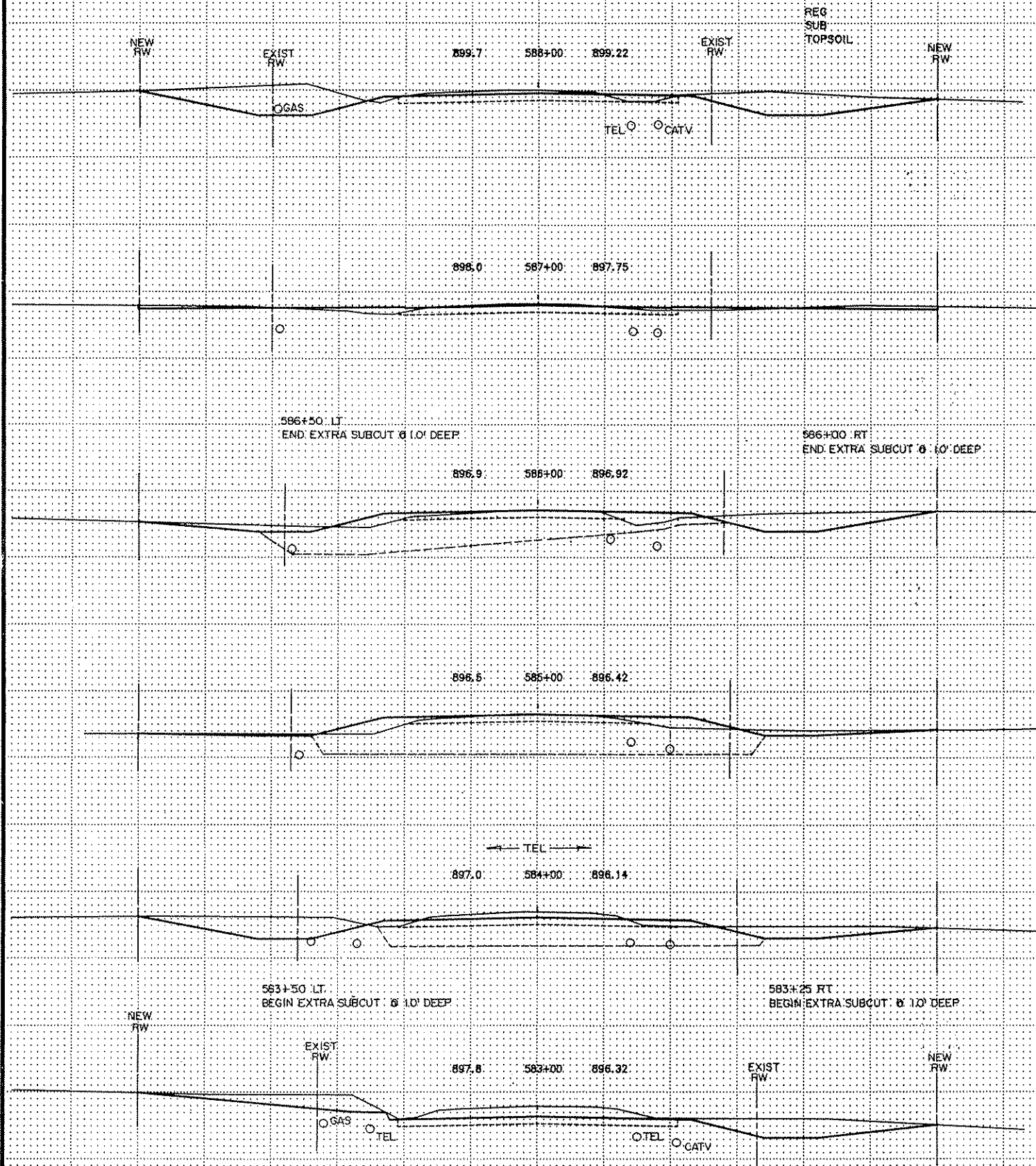

NOTE: UTILITY ELEVATIONS ASSUMED
NOT ACTUAL

10'
10'

CROSS-SECTIONS
STA. 583+00 TO STA. 593+00

PLATE 3 Full Cross Section DOTTED blueprint Order Form MAB Plate 30V

EXCAVATION SUB-TOTALS CU.YDS. EMBANKMENT SUB-TOTALS CU.YDS.

EXCAVATION SUB-TOTALS CU.YDS. EMBANKMENT SUB-TOTALS CU.YDS.

REG SUB TOPSOIL

REG SUB TOPSOIL

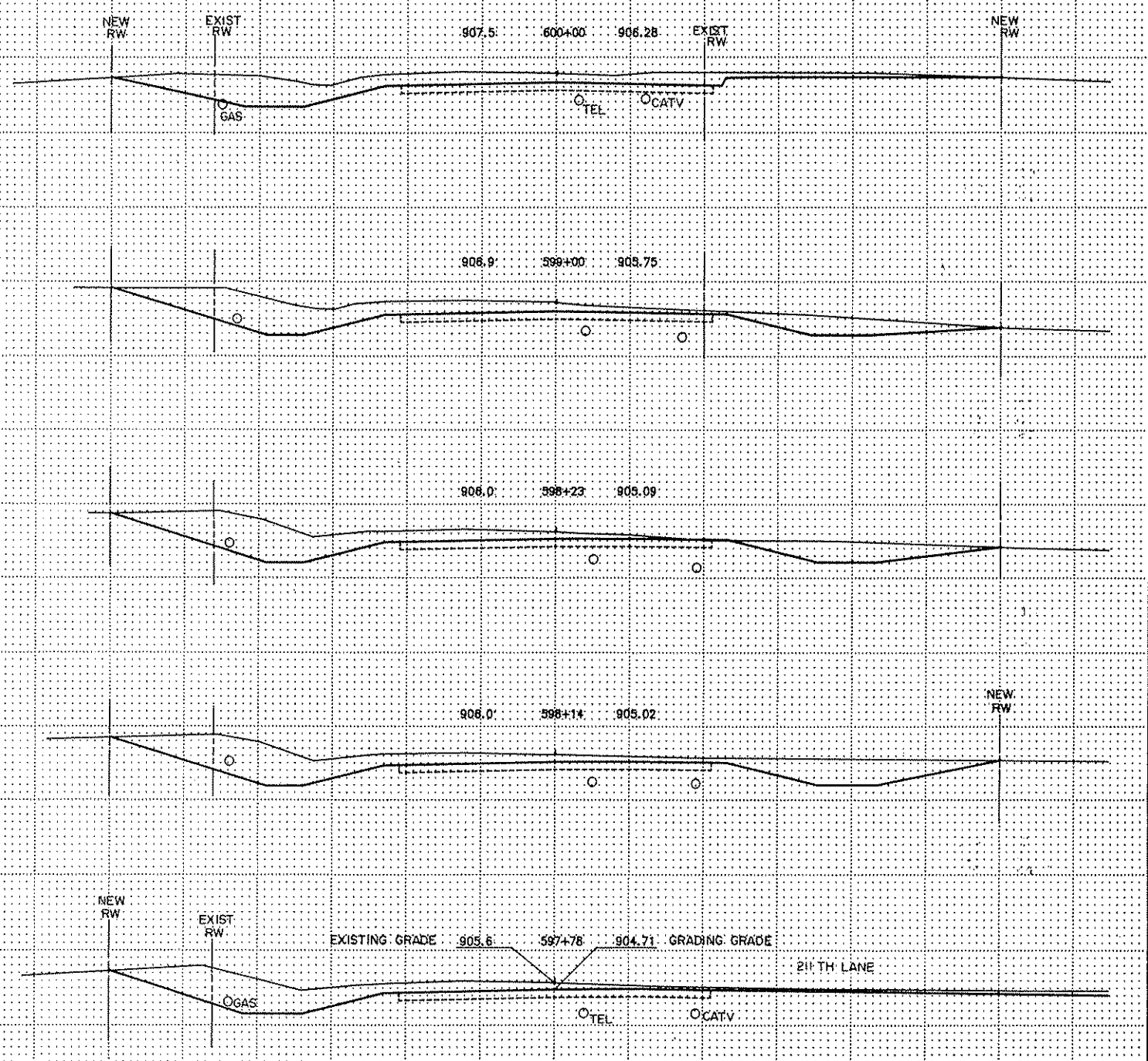
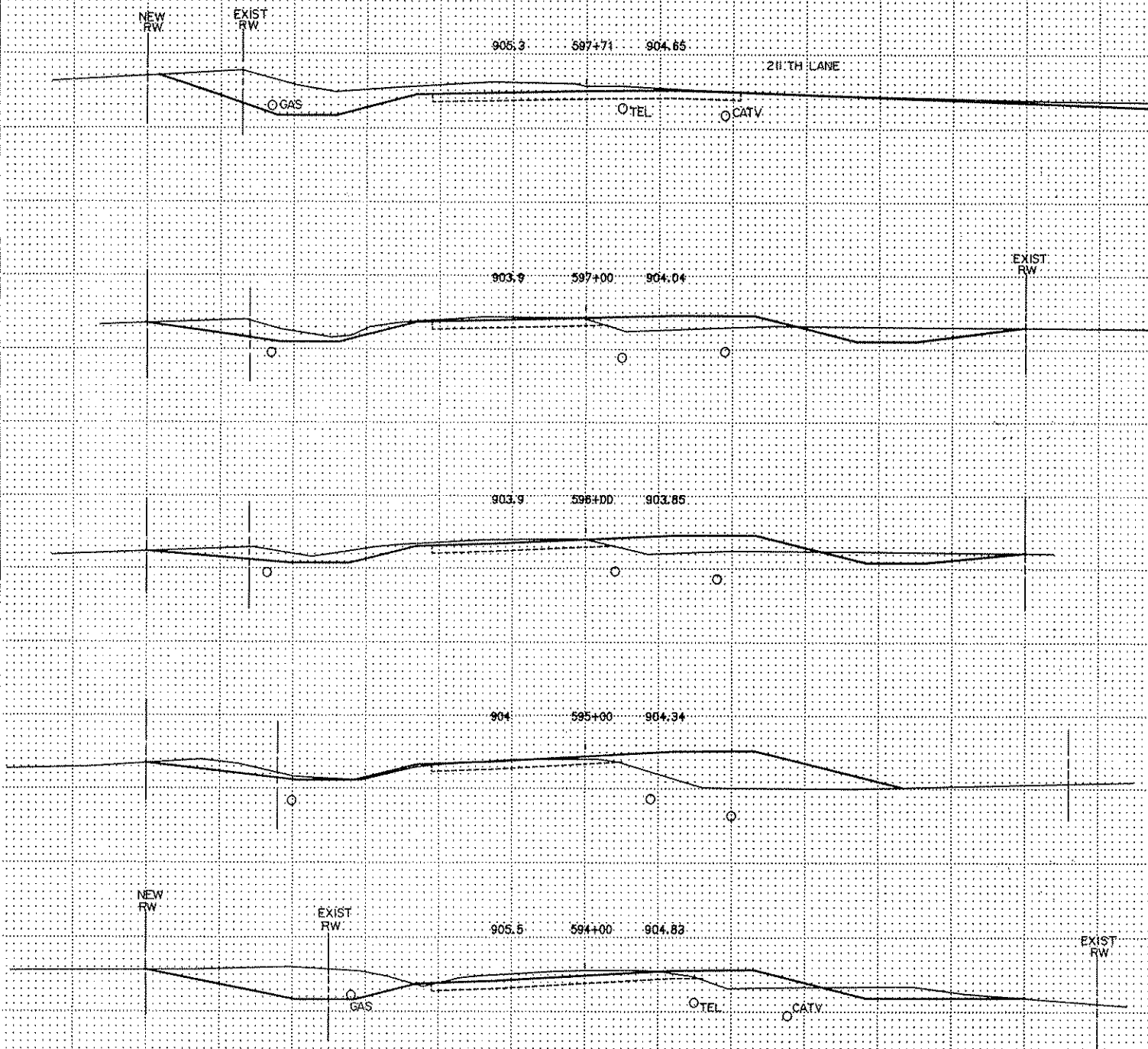

NOTE: UTILITY ELEVATIONS ASSUMED NOT ACTUAL

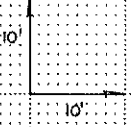

EXISTING GRADE 905.6 597+78 904.71 GRADING GRADE

PLATE 3 For Cross Section DOTTED Clear Form 1018 Plate 3DV

CROSS-SECTIONS STA. 594+00 TO STA. 600+00

EXCAVATION EMBANKMENT
SUB-TOTALS CU.YDS. SUB-TOTALS CU.YDS.

EXCAVATION EMBANKMENT
SUB-TOTALS CU.YDS. SUB-TOTALS CU.YDS.

605+00 RT
BEGIN EXTRA SUBCUT @ 10' DEEP

REG
SUB
TOPSOIL

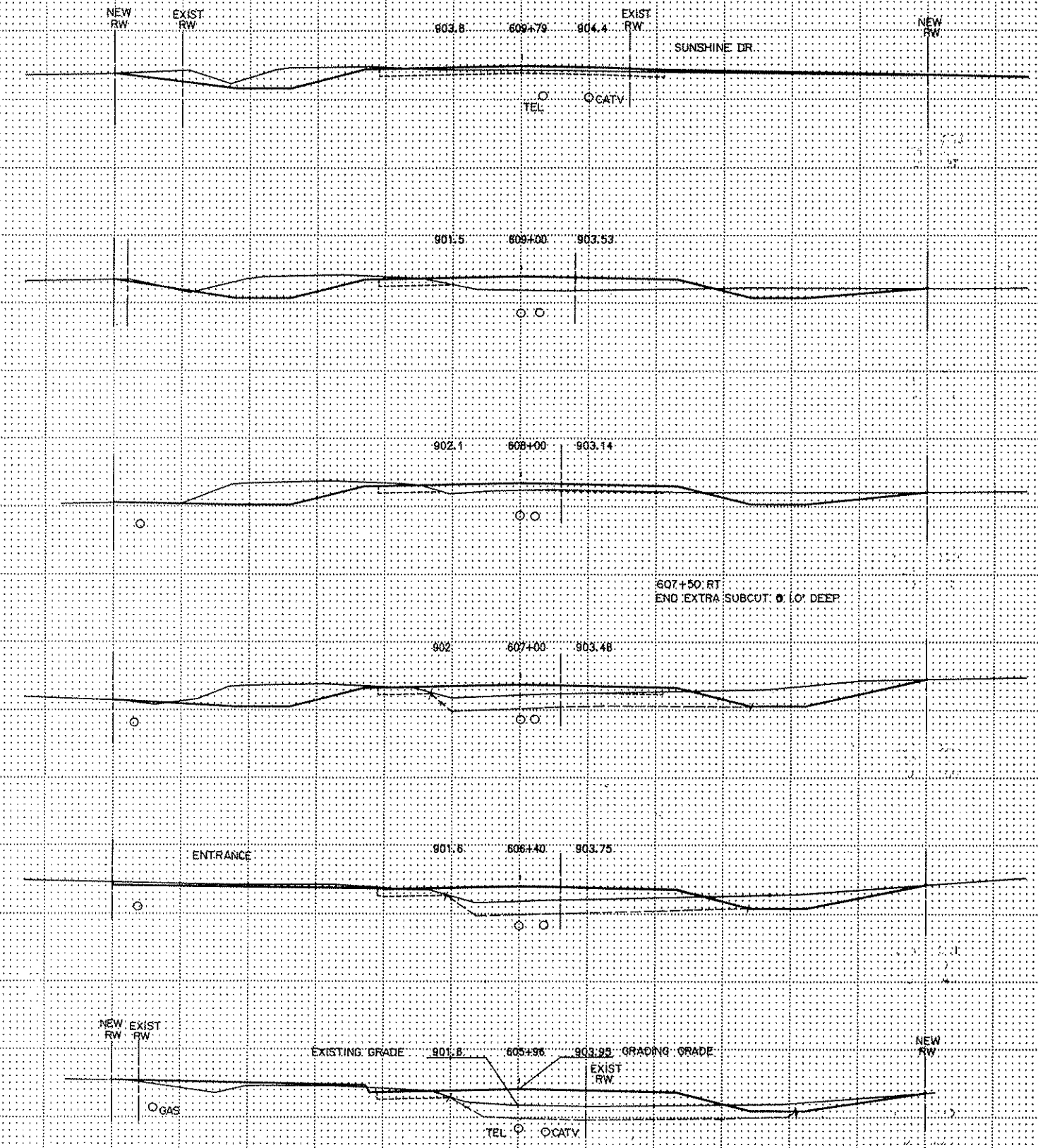
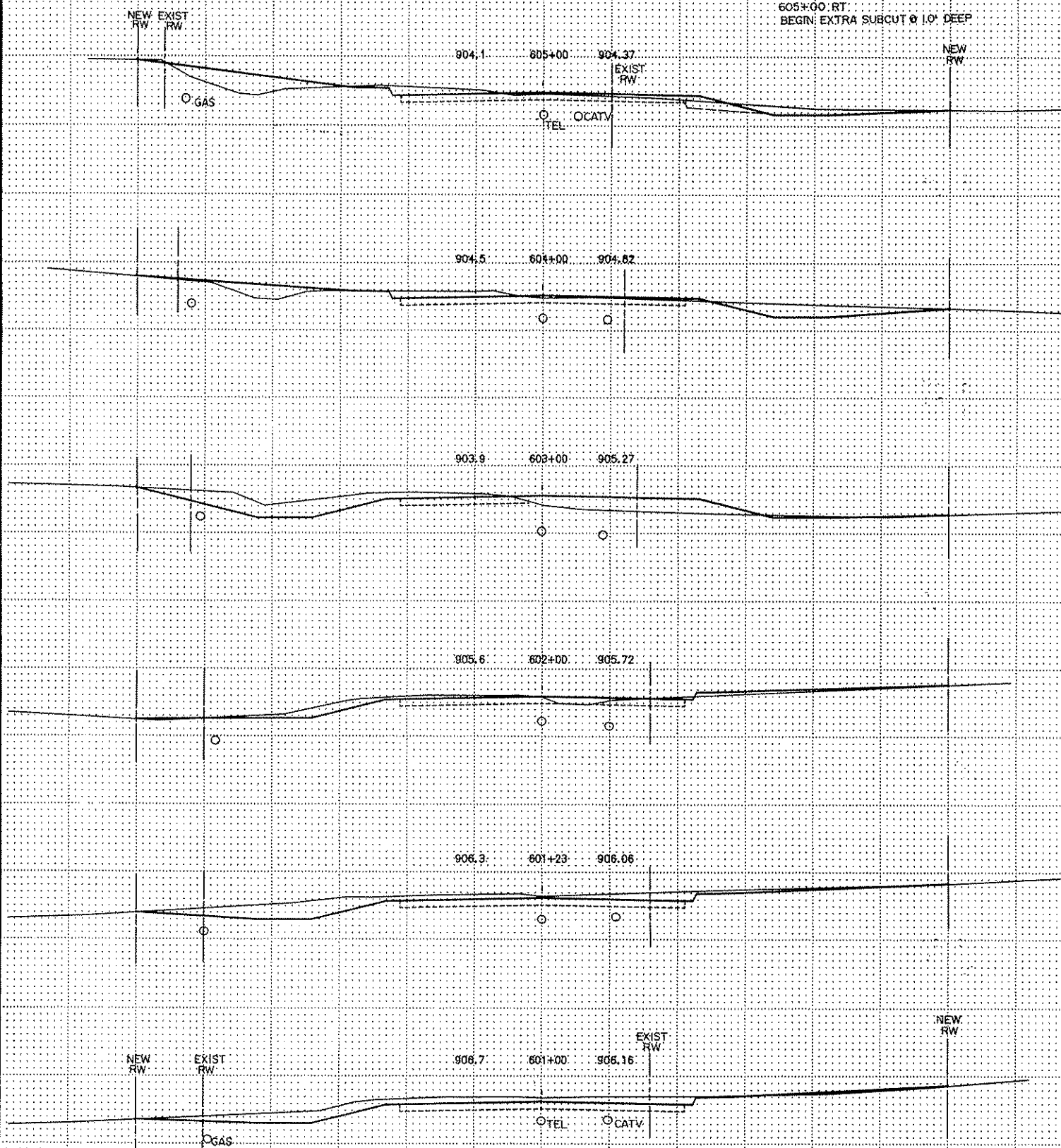

NOTE: UTILITY ELEVATIONS ASSUMED
NOT ACTUAL

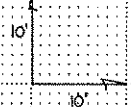

EXISTING GRADE 901.8 805+36 903.22 GRADING GRADE

CROSS-SECTIONS
STA: 601+00 TO STA: 809+79

PLATE 3 Full Cross Section 30" x 30" blue print. Order Form 148 Page 30V

PLATE 3 E-4 Cross Section DOTTED blueprint 1:30 Form ANB Page 3DV

EXCAVATION SUB-TOTALS CU.YDS. EMBANKMENT SUB-TOTALS CU.YDS.

EXCAVATION SUB-TOTALS CU.YDS. EMBANKMENT SUB-TOTALS CU.YDS.

REG SUB TOPSOIL

REG SUB TOPSOIL

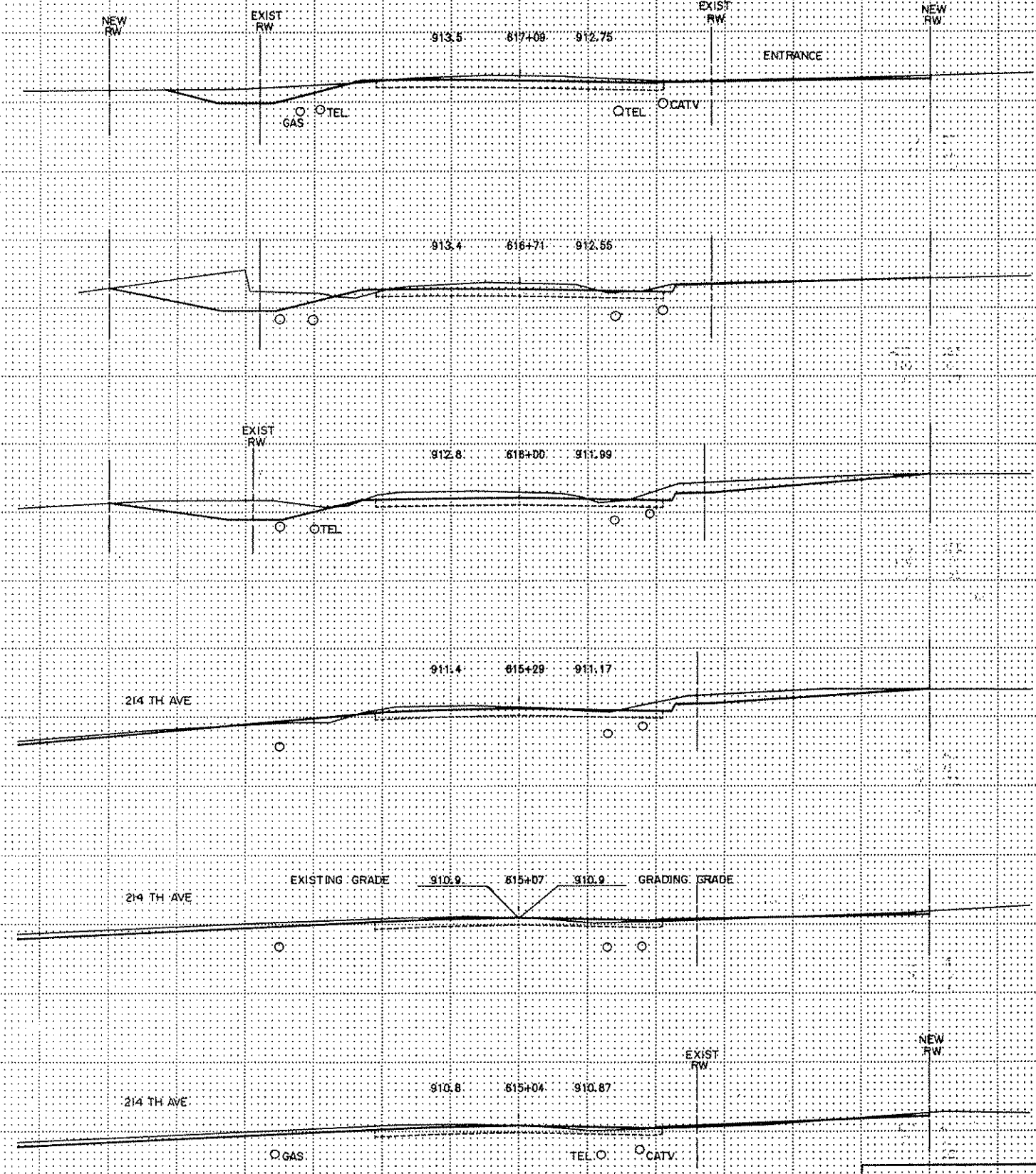
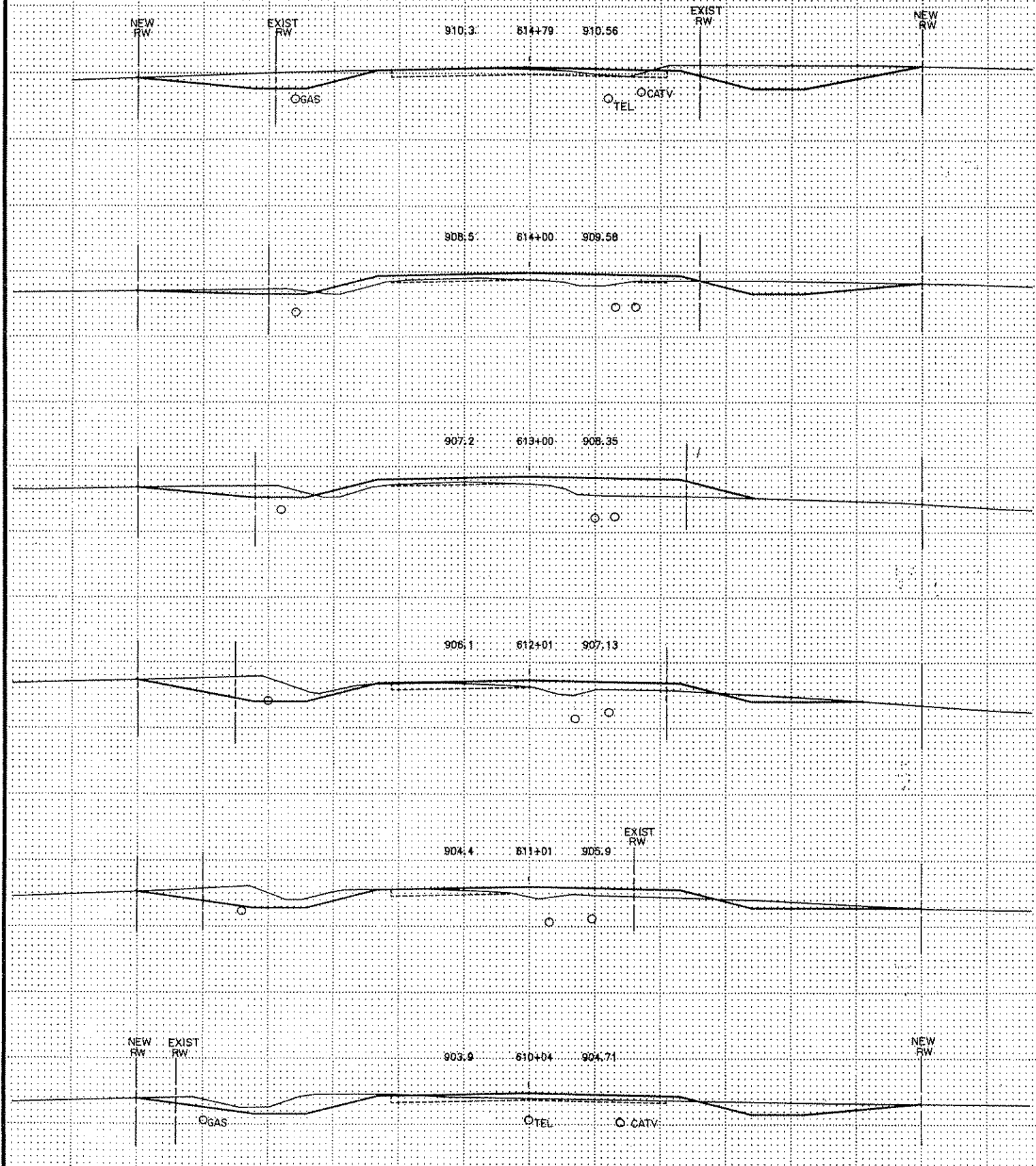

NOTE: UTILITY ELEVATIONS ASSUMED NOT ACTUAL

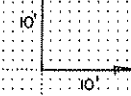

CROSS-SECTIONS: STA. 610+04 TO STA. 617+09

PLATE 3 Full Cross Section - DOTTED Clear Form 145B Page 3DV blueprint

EXCAVATION SUB-TOTALS CU.YDS. EMBANKMENT SUB-TOTALS CU.YDS.

EXCAVATION SUB-TOTALS CU.YDS. EMBANKMENT SUB-TOTALS CU.YDS.

REG SUB TOPSOIL

REG SUB TOPSOIL

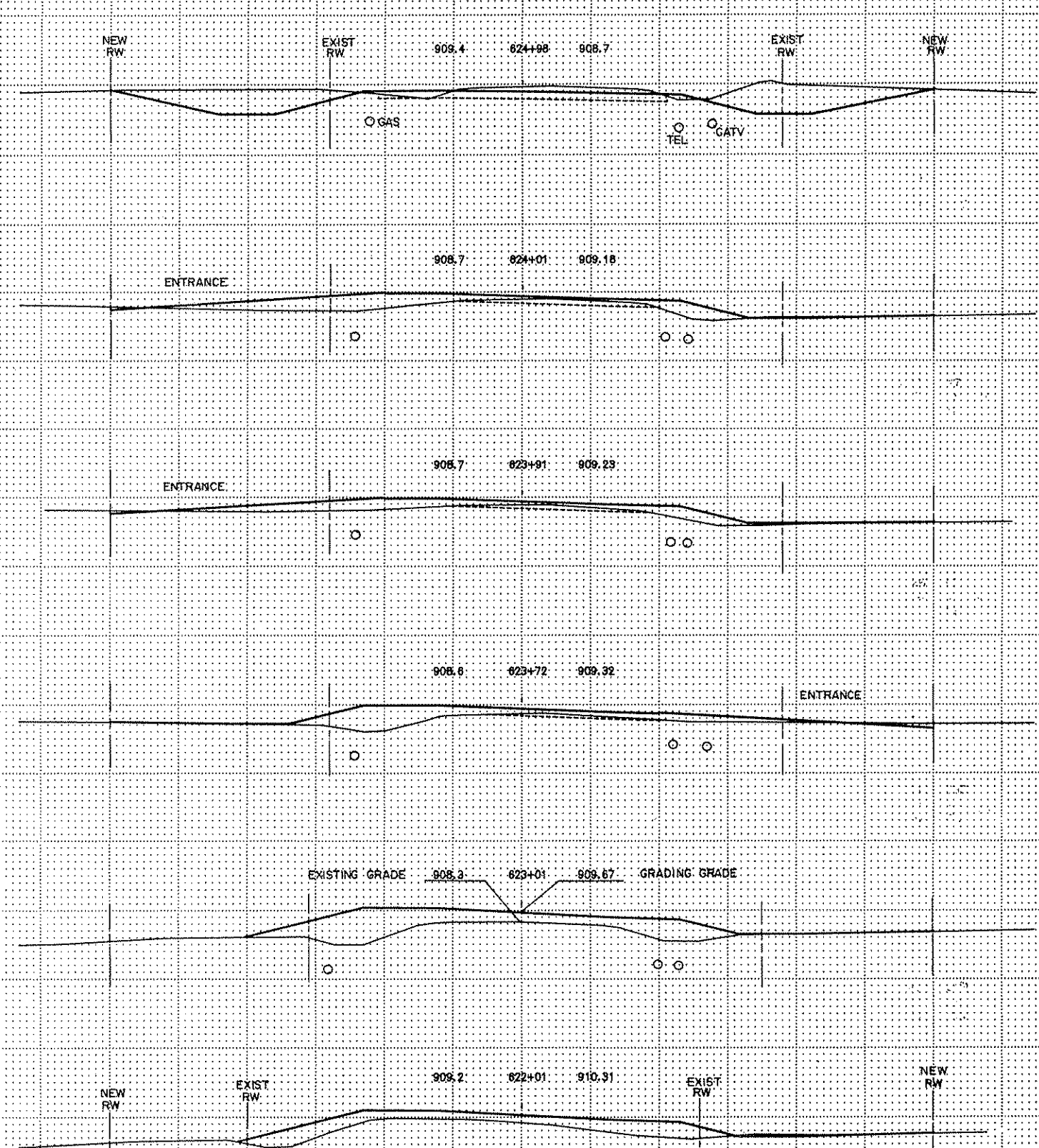
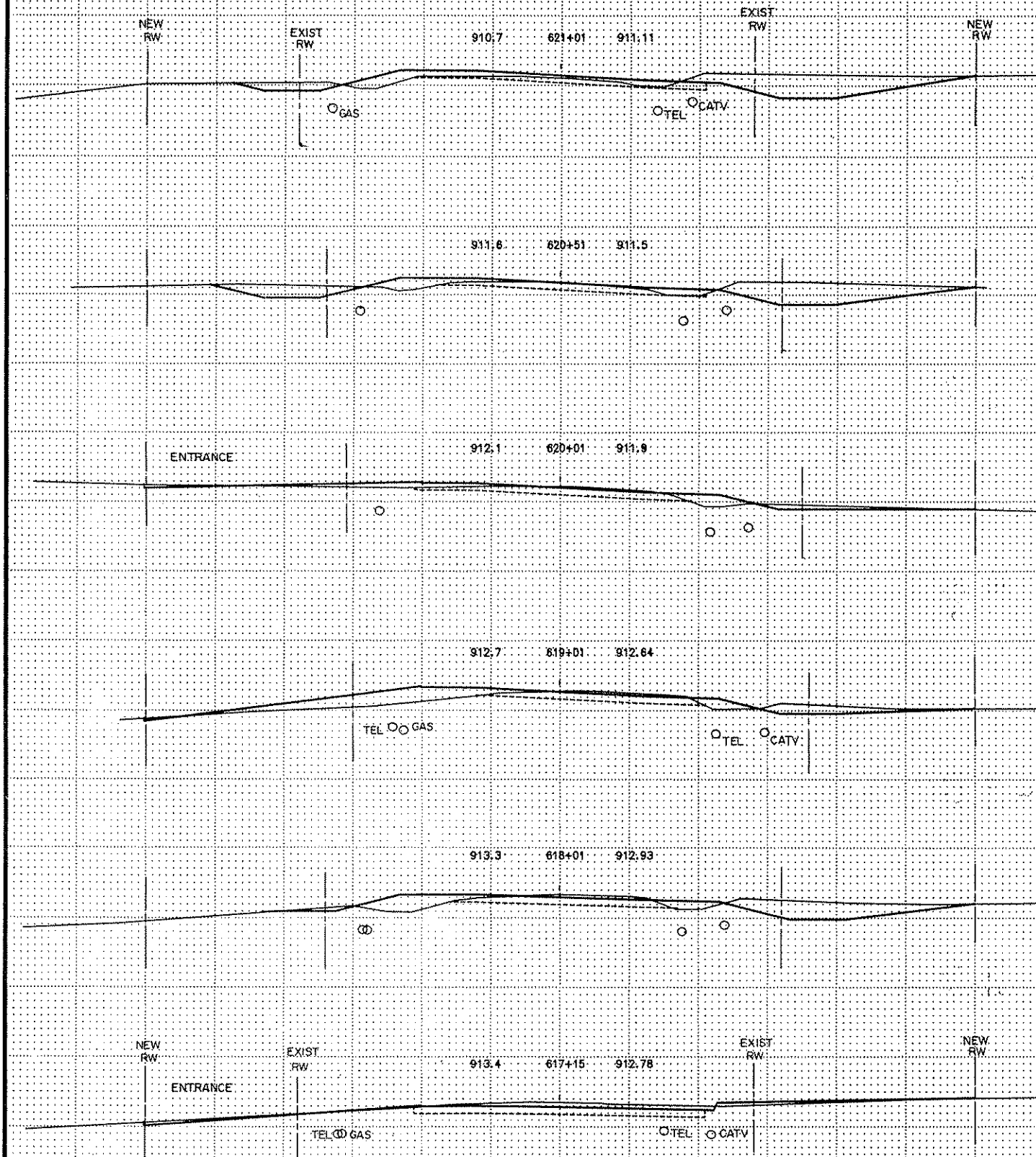

NOTE: UTILITY ELEVATIONS ASSUMED NOT ACTUAL

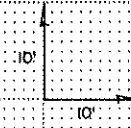

CROSS-SECTIONS STA. 617+15 TO STA. 624+98

EXCAVATION EMBANKMENT
SUB-TOTALS CU.YDS. SUB-TOTALS CU.YDS.

EXCAVATION EMBANKMENT
SUB-TOTALS CU.YDS. SUB-TOTALS CU.YDS.

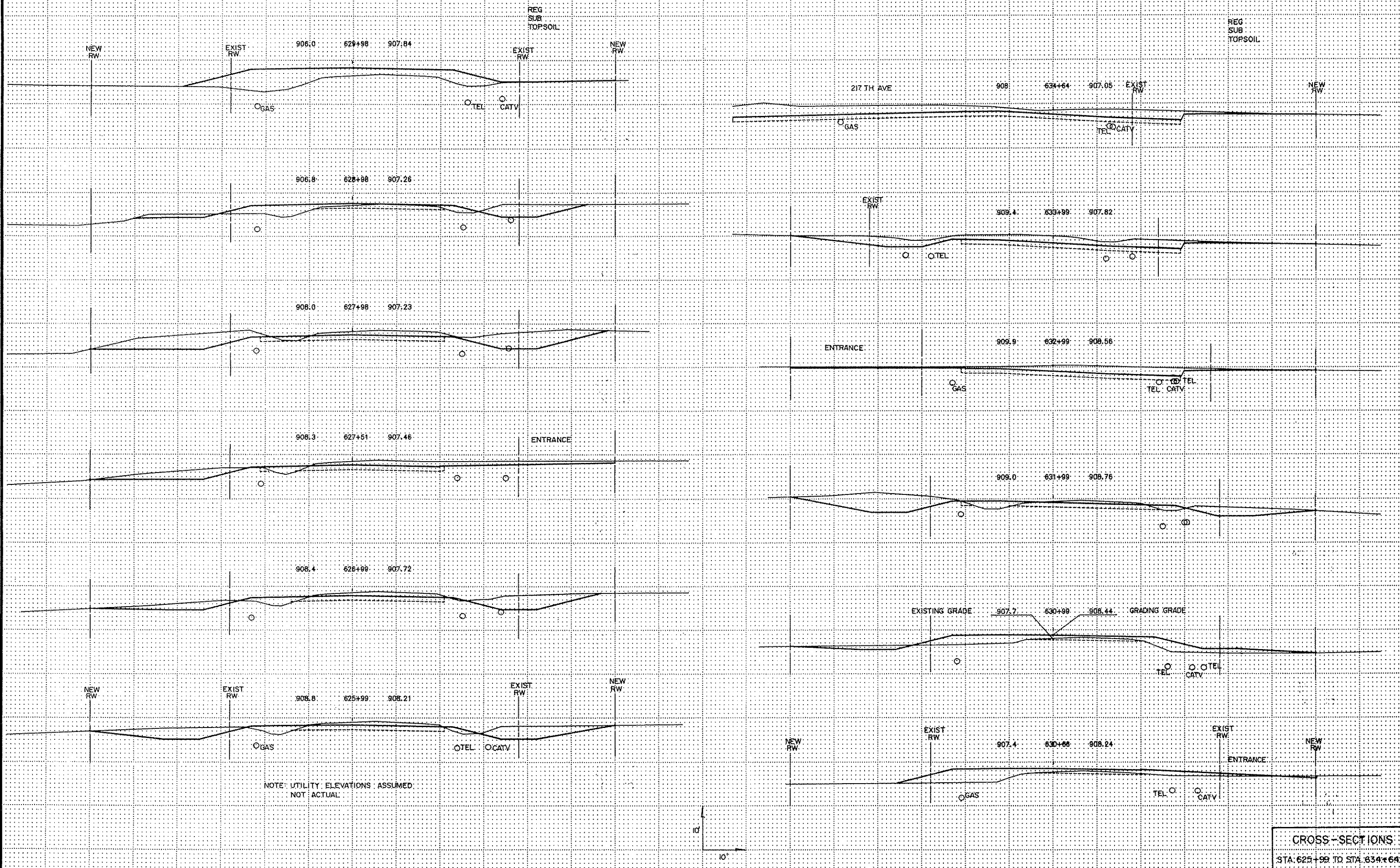

NOTE: UTILITY ELEVATIONS ASSUMED NOT ACTUAL

CROSS-SECTIONS
STA. 625+99 TO STA. 634+64

PLATE 3 Full Cross Section DOTTED blueprint. Order Form NMB Plate 30V

PLATE 3 Full Cross Section DOTTED Blueprint Order Form: NWS Plate 30Y

EXCAVATION EMBANKMENT
SUB-TOTALS CU.YDS. SUB-TOTALS CU.YDS.
REG SUB TOPSOIL

EXCAVATION EMBANKMENT
SUB-TOTALS CU.YDS. SUB-TOTALS CU.YDS.
REG SUB TOPSOIL

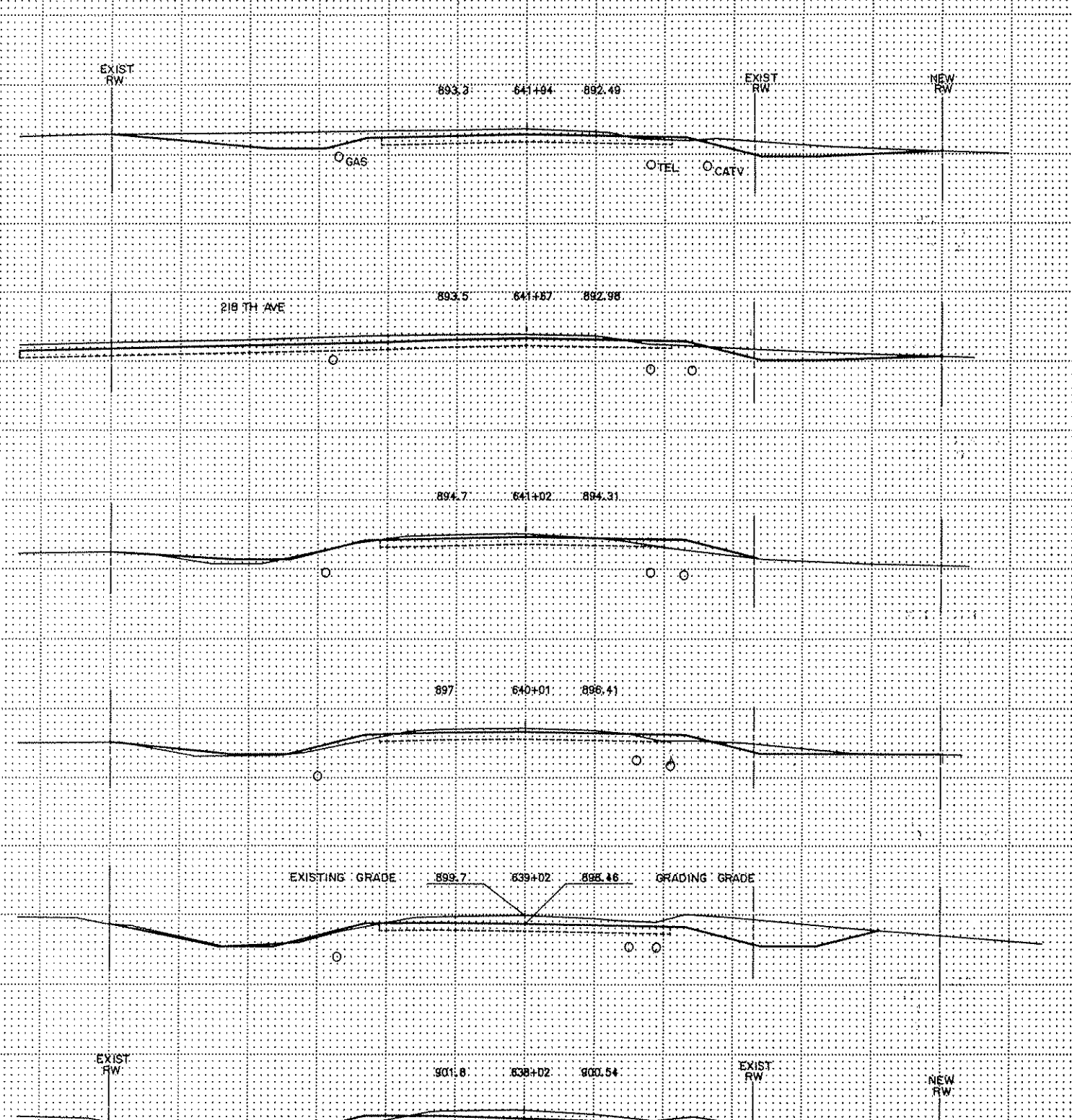
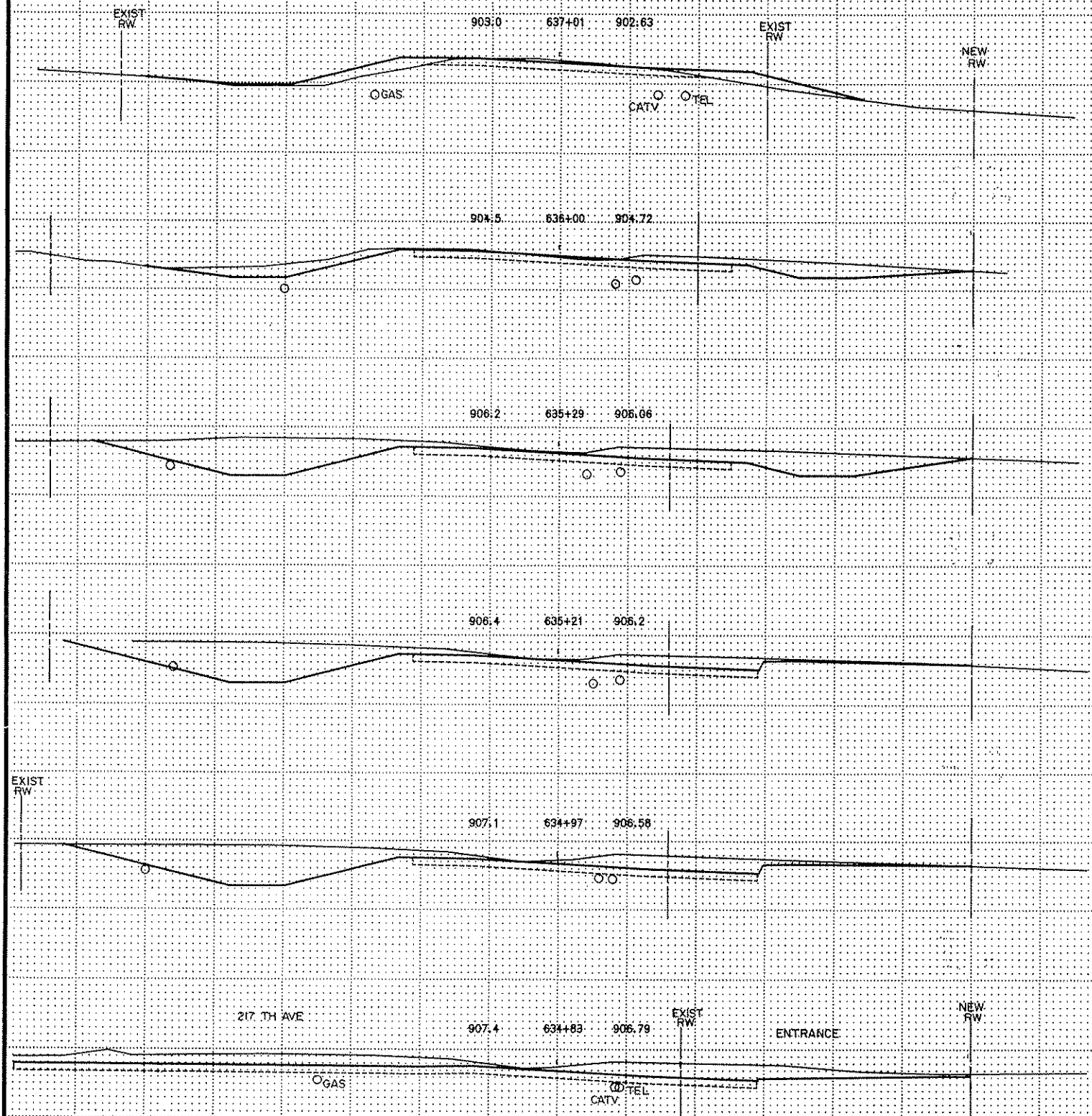

NOTE: UTILITY ELEVATIONS ASSUMED NOT ACTUAL

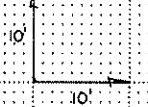

EXCAVATION EMBANKMENT
 SUB-TOTALS CU.YDS. SUB-TOTALS CU.YDS.

EXCAVATION EMBANKMENT
 SUB-TOTALS CU.YDS. SUB-TOTALS CU.YDS.

REG
 SUB
 TOPSOIL

REG
 SUB
 TOPSOIL

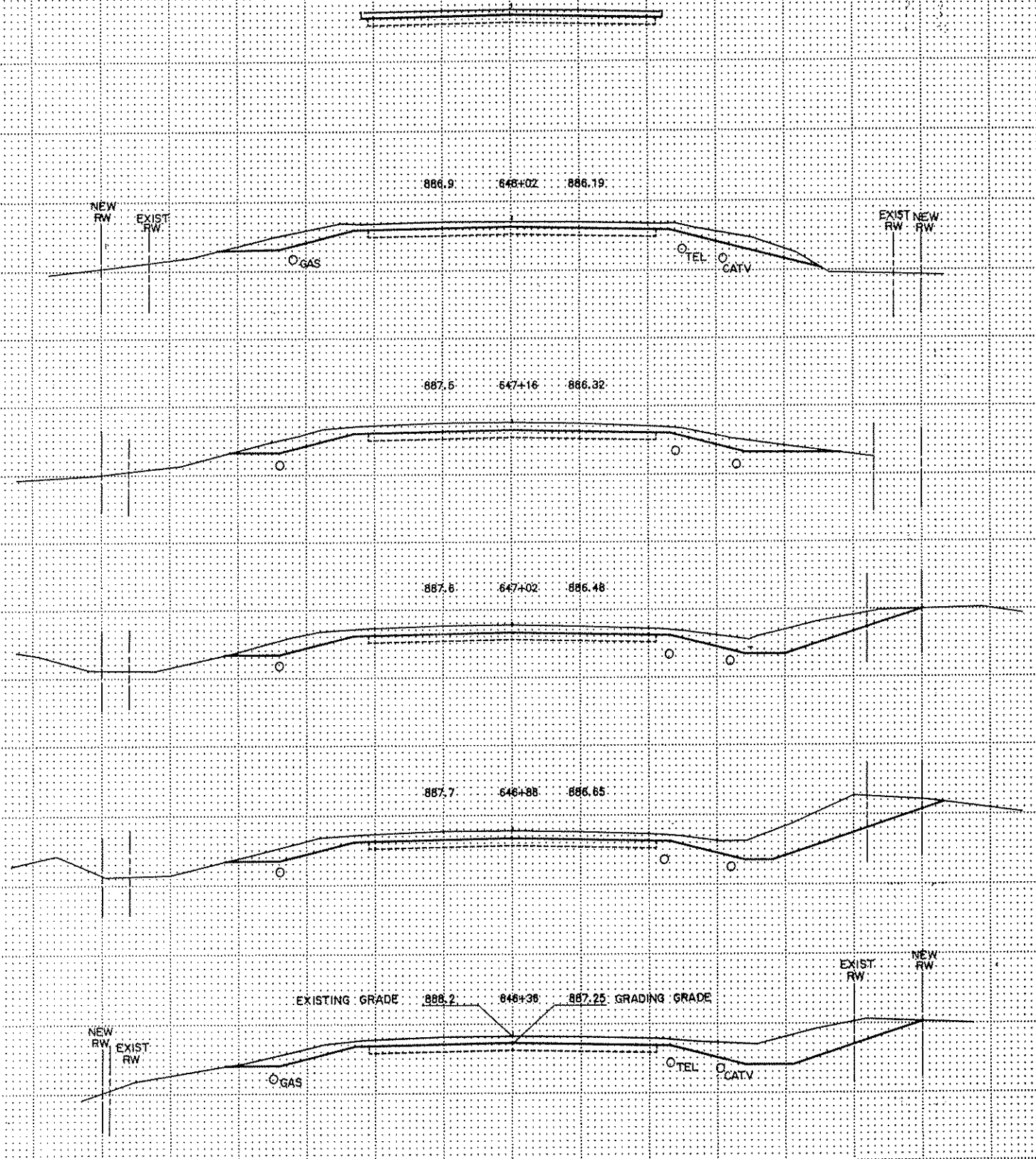
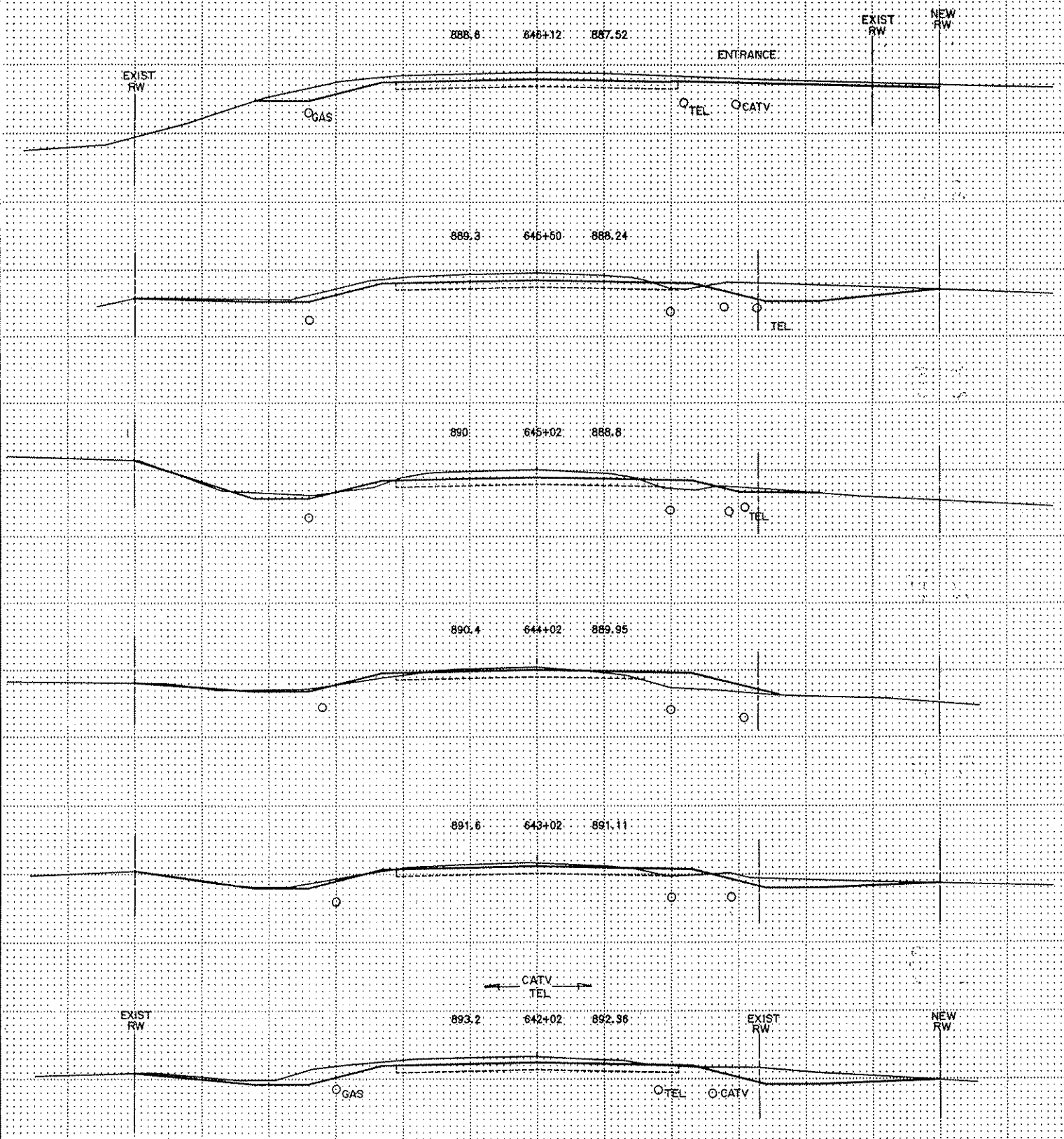

NOTE: UTILITY ELEVATIONS ASSUMED.
 NOT ACTUAL.

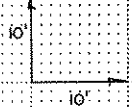

CROSS-SECTIONS
 STA. 642+02 TO STA. 648+41

PLATE 3 Full Cross Section DOTTED Order Form M&B Plate 3DY

PLATE 3 Full Cross Section, DOTTED blueprint, Order Form: M&S Print .JCV

EXCAVATION EMBANKMENT
SUB-TOTALS CU.YDS. SUB-TOTALS CU.YDS.

EXCAVATION EMBANKMENT
SUB-TOTALS CU.YDS. SUB-TOTALS CU.YDS.

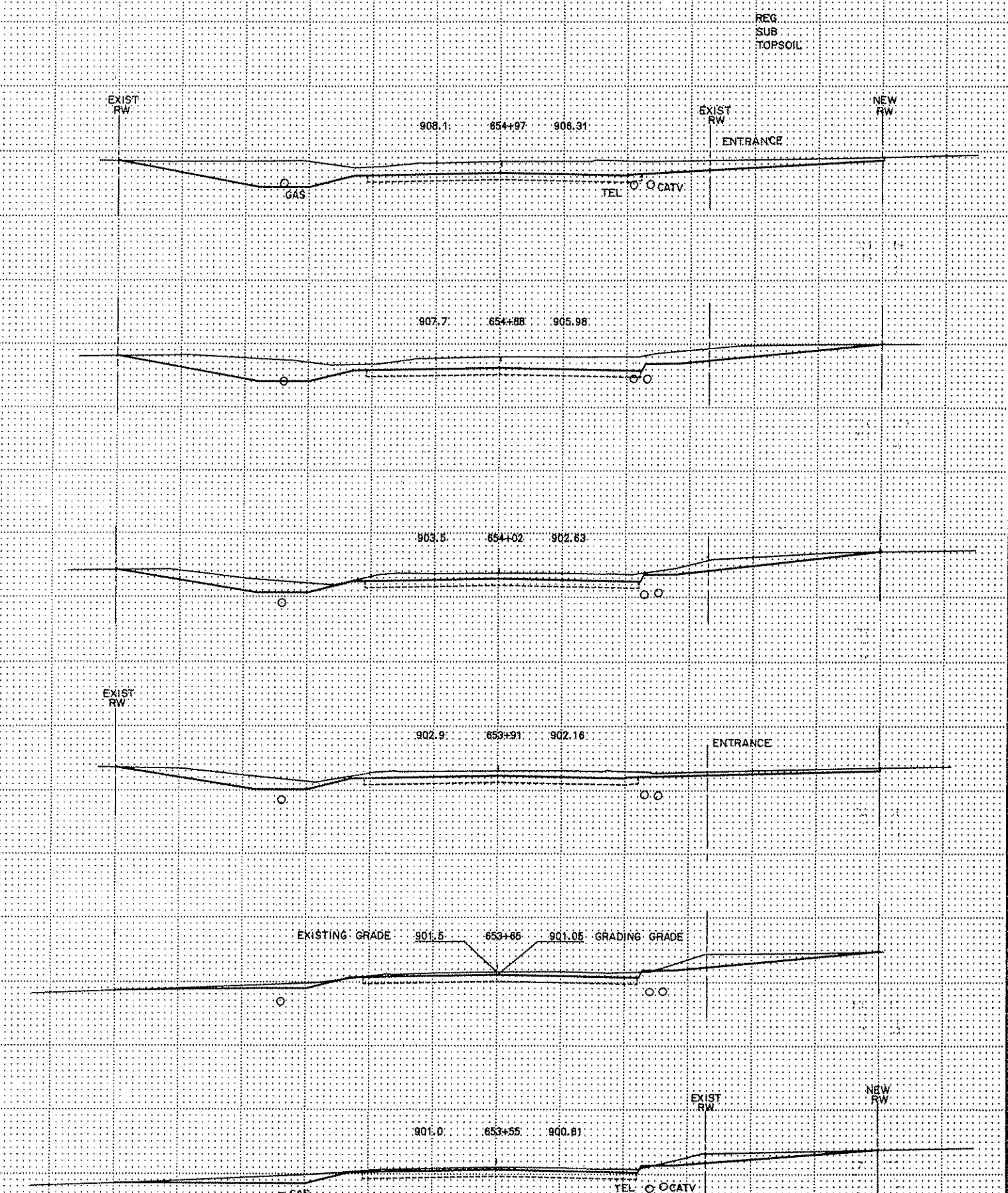
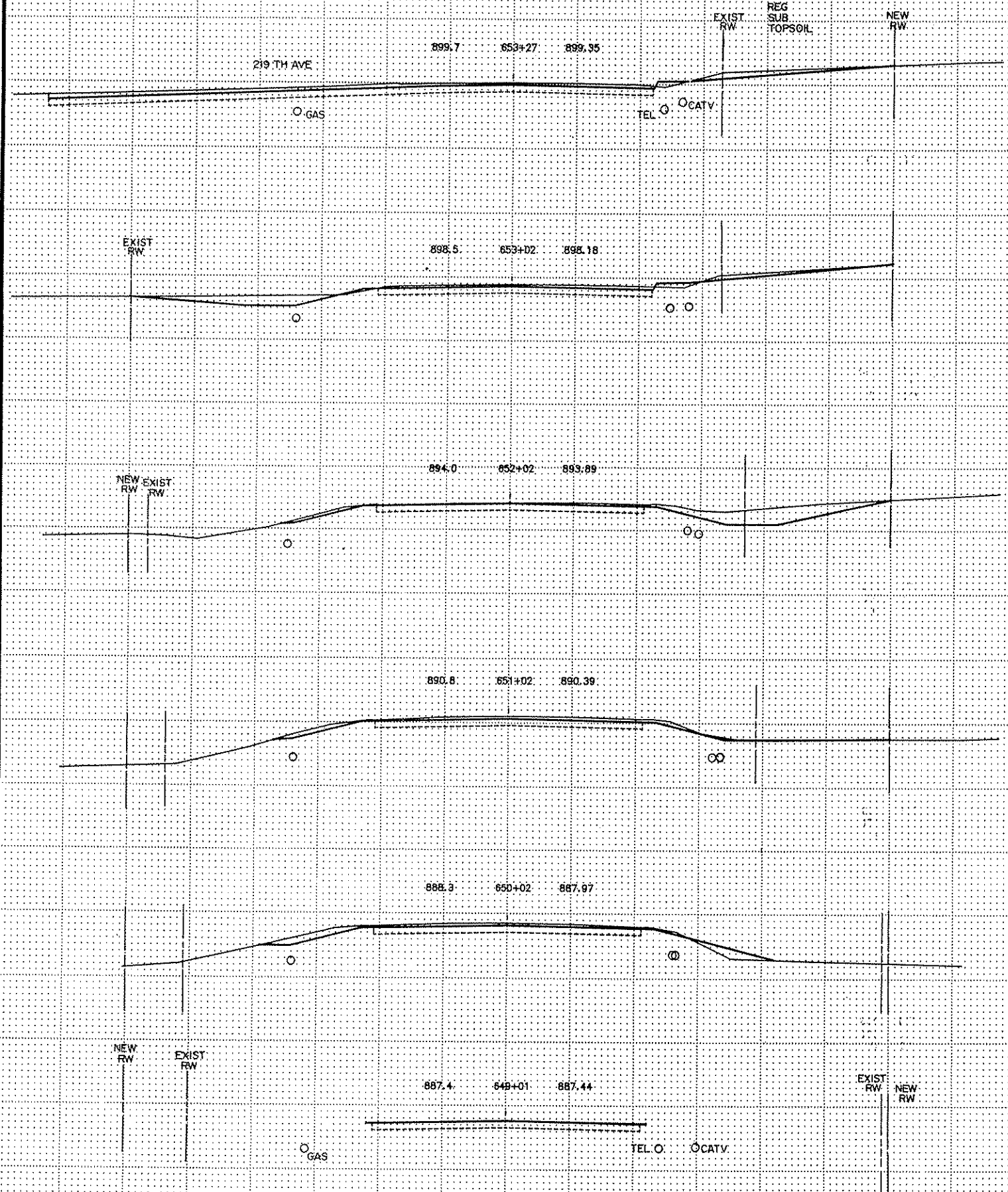

NOTE: UTILITY ELEVATIONS ASSUMED
NOT ACTUAL

10'
10'

CROSS-SECTIONS
STA. 649+01 TO STA. 654+97

EXCAVATION EMBANKMENT
 SUB-TOTALS CU.YDS. SUB-TOTALS CU.YDS.

EXCAVATION EMBANKMENT
 SUB-TOTALS CU.YDS. SUB-TOTALS CU.YDS.

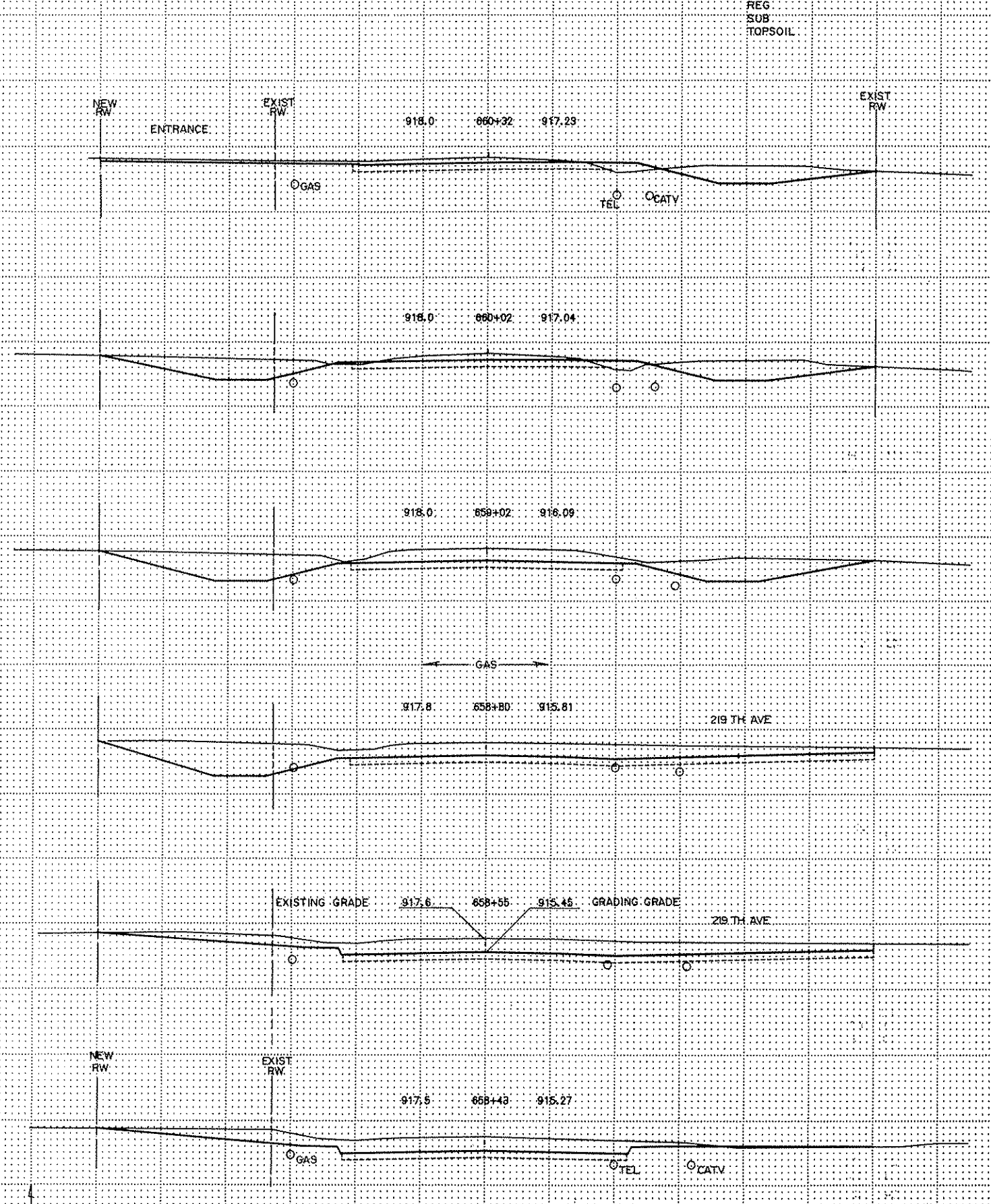
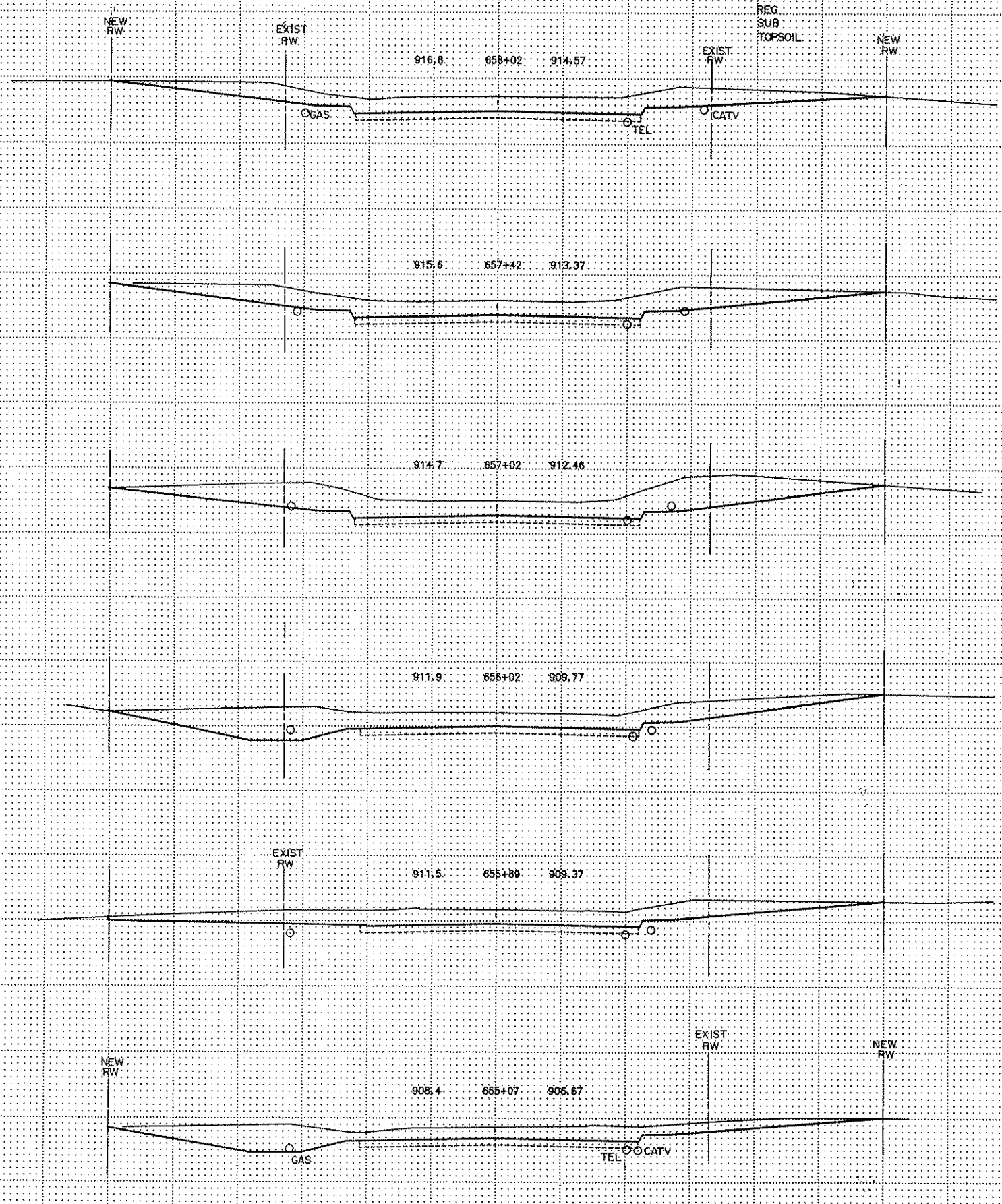

NOTE: UTILITY ELEVATIONS ASSUMED NOT ACTUAL

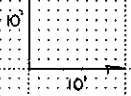

CROSS-SECTIONS

STA. 655+07 TO STA. 660+42

EXCAVATION EMBANKMENT
SUB-TOTALS CU.YDS. SUB-TOTALS CU.YDS.

EXCAVATION EMBANKMENT
SUB-TOTALS CU.YDS. SUB-TOTALS CU.YDS.

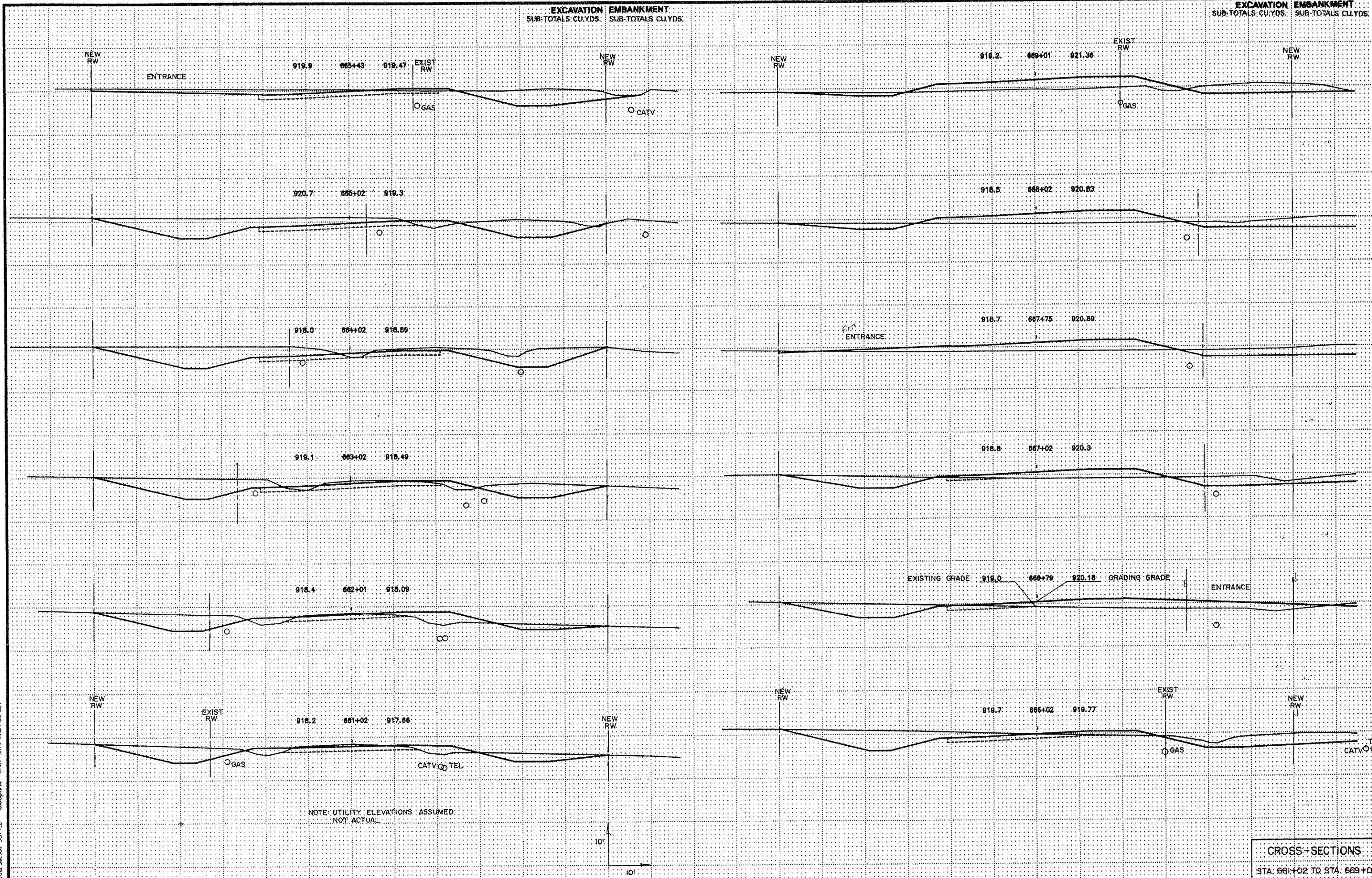

NOTE: UTILITY ELEVATIONS ASSUMED
NOT ACTUAL

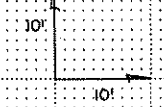

CROSS-SECTIONS
STA. 661+02 TO STA. 669+01

PLATE 3 Full Cross Section, DOTTED Order Form VAB Plate 30V

EXCAVATION EMBANKMENT
 SUB-TOTALS CU.YDS. SUB-TOTALS CU.YDS.
 REG 1236 161
 SUB 156 0
 TOPSOIL 0 III

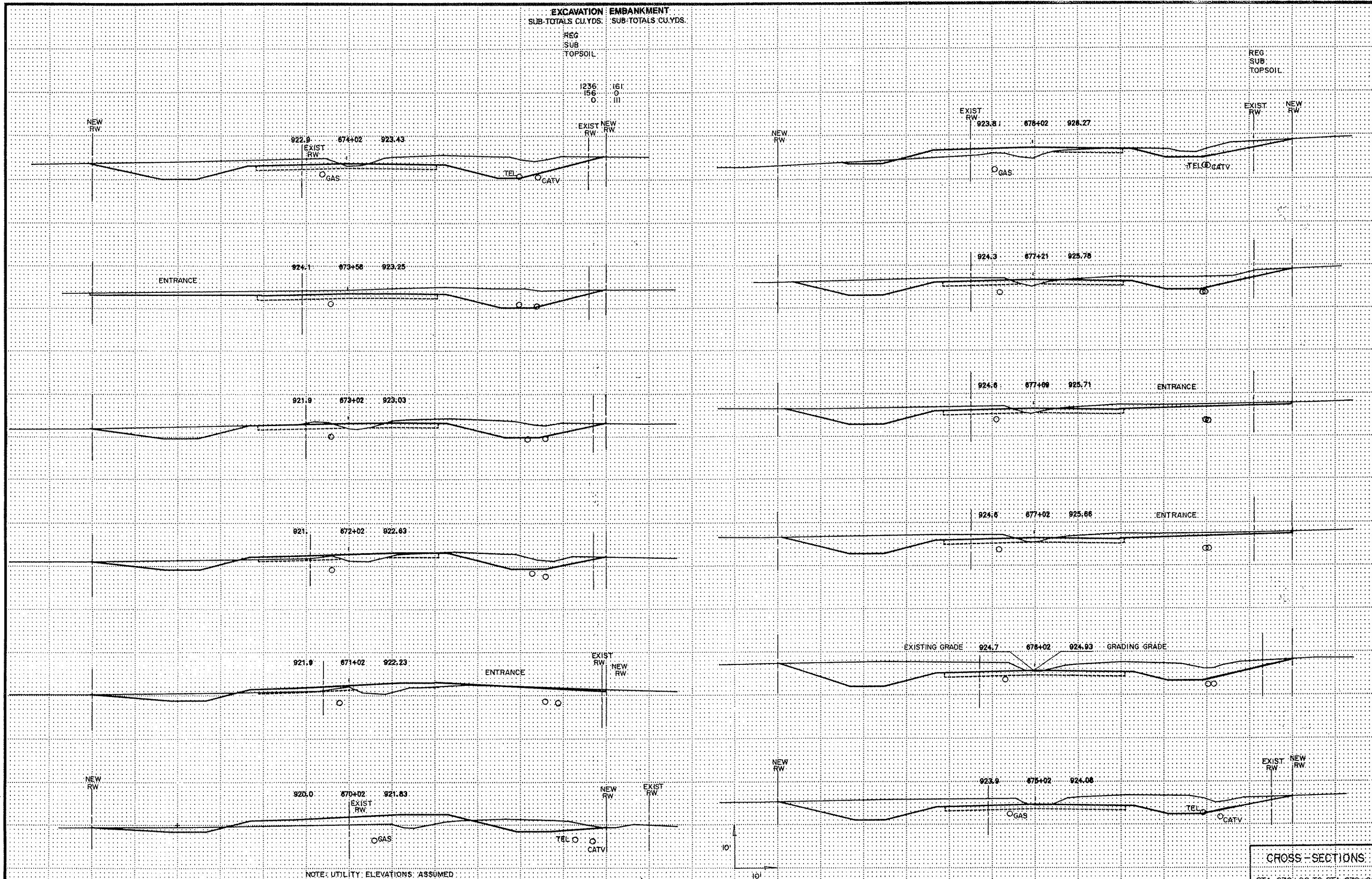

NOTE: UTILITY ELEVATIONS ASSUMED
 NOT ACTUAL

CROSS-SECTIONS
 STA. 670+02 TO STA. 678+02

PLATE 3 Full Cross Section DOTTED blueprint
 Order Form VMB Page 3DV

EXCAVATION EMBANKMENT
SUB-TOTALS CU.YDS. SUB-TOTALS CU.YDS.

EXCAVATION EMBANKMENT
SUB-TOTALS CU.YDS. SUB-TOTALS CU.YDS.

REG.
SUB.
TOPSOIL

REG.
SUB.
TOPSOIL

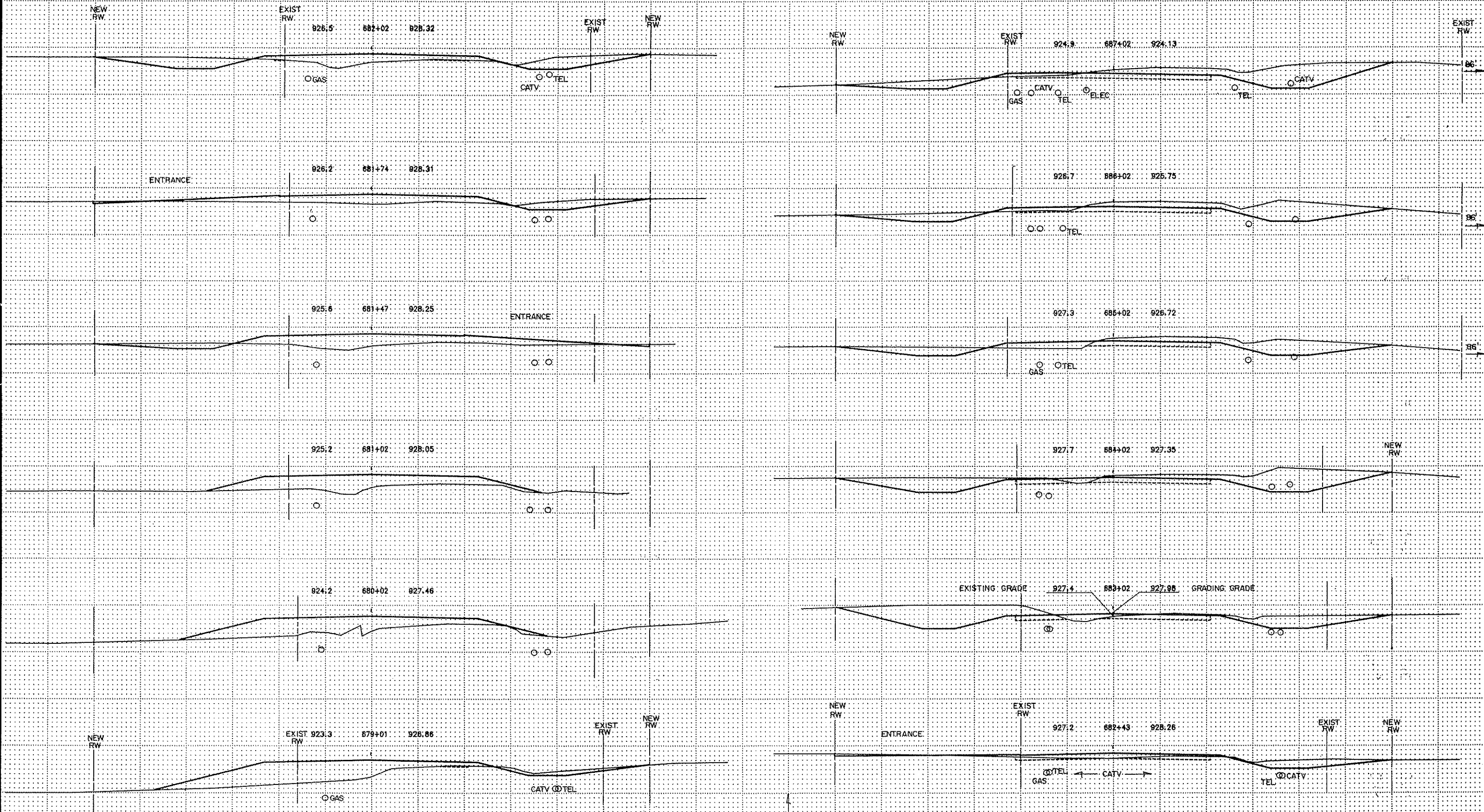

NOTE: UTILITY ELEVATIONS ASSUMED.
NOT ACTUAL

CROSS-SECTIONS
STA 679+01 TO STA 687+02

PLATE 3 Full Cross Section DOTTED blueprint Order Form MAB Plate 30V

EXCAVATION EMBANKMENT
SUB-TOTALS CU.YDS. SUB-TOTALS CU.YDS.

EXCAVATION EMBANKMENT
SUB-TOTALS CU.YDS. SUB-TOTALS CU.YDS.

REG.
SUB.
TOPSOIL

REG.
SUB.
TOPSOIL

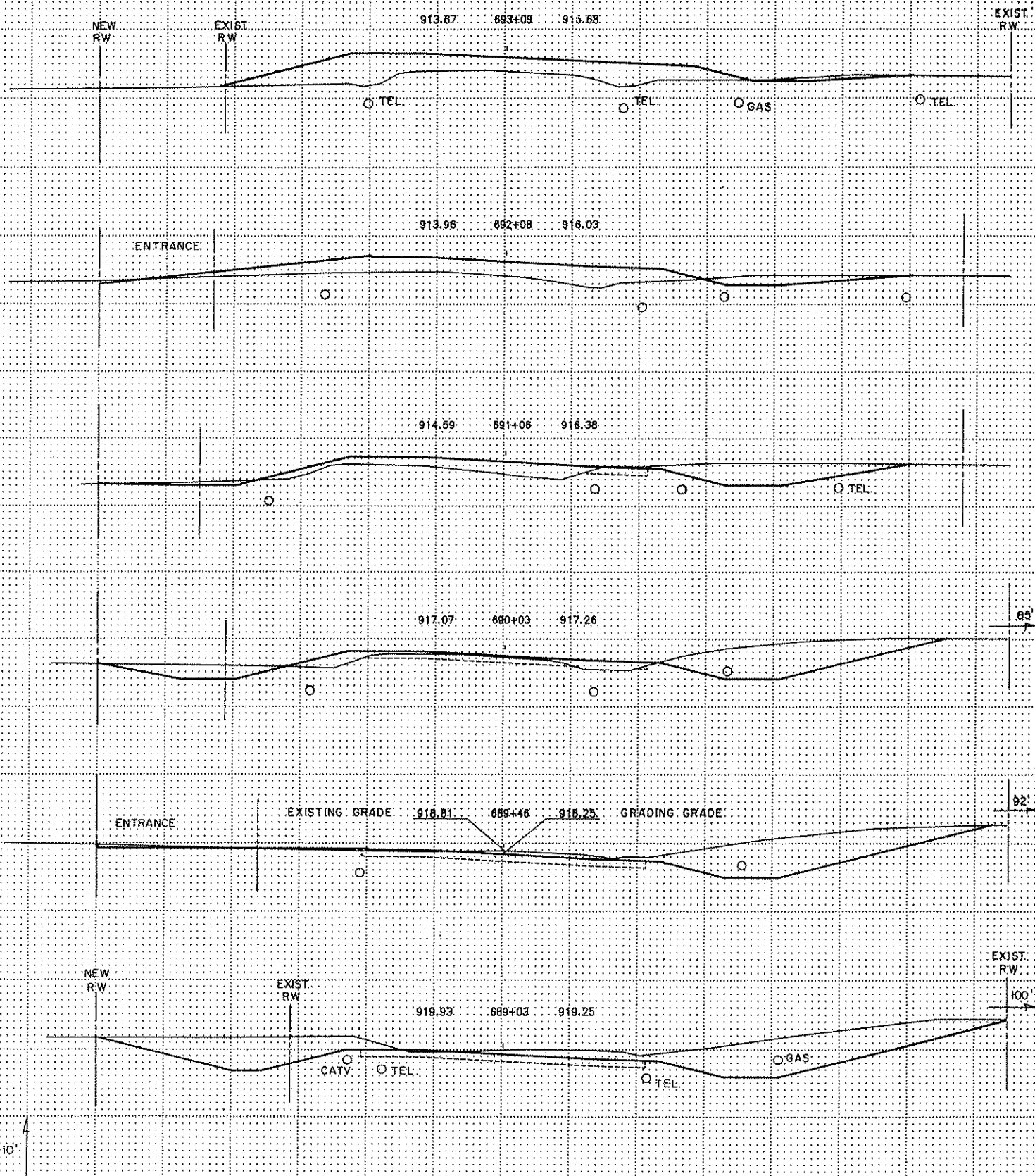
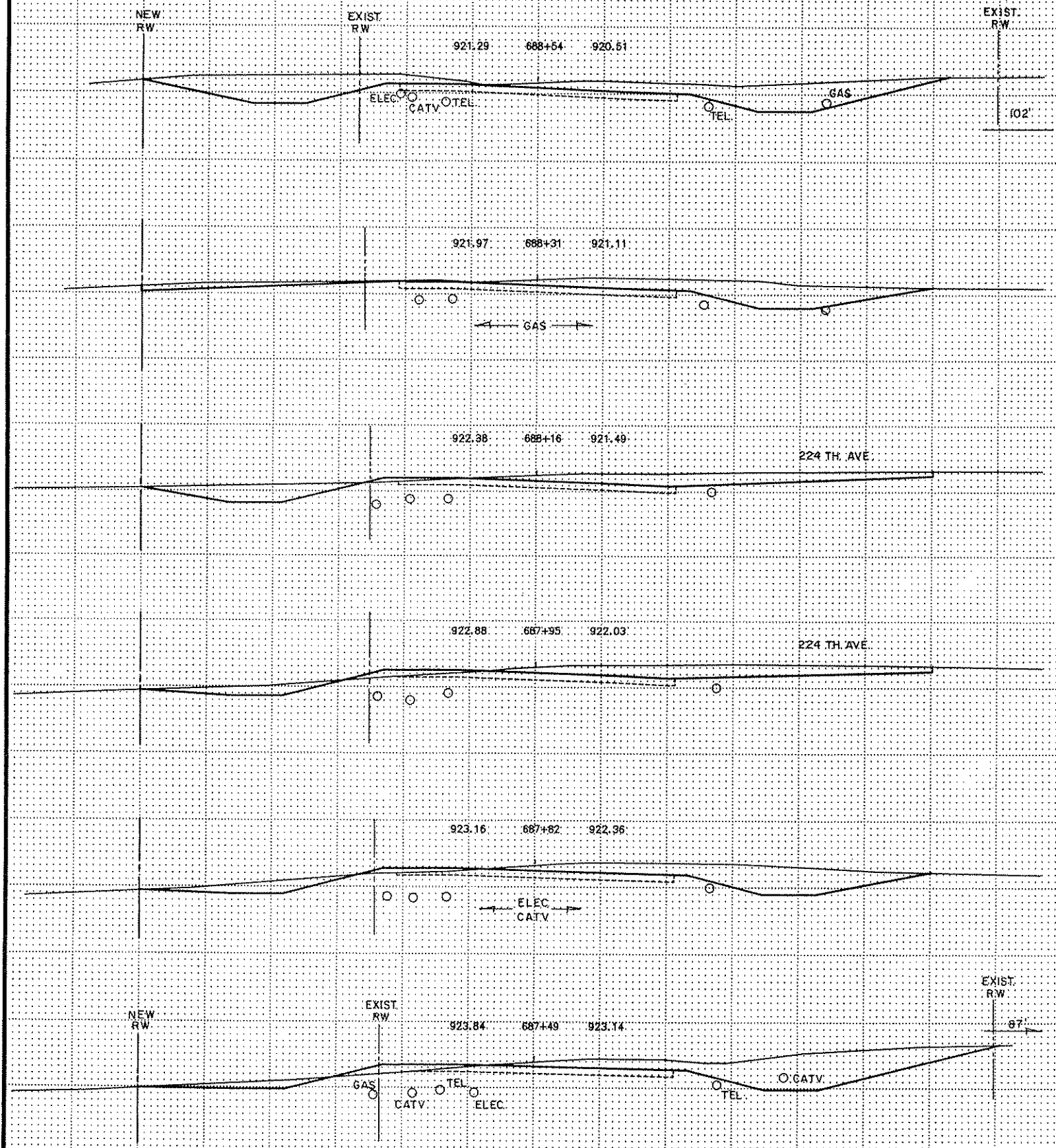

NOTE: UTILITY ELEVATIONS ASSUMED
NOT ACTUAL

PLATE 3 F&E Cross Section DOTTED Order Form M&B Plate 3DY

CROSS-SECTIONS
STA. 687+49 TO STA. 693+09

EXCAVATION EMBANKMENT
SUB-TOTALS CU.YDS. SUB-TOTALS CU.YDS.

EXCAVATION EMBANKMENT
SUB-TOTALS CU.YDS. SUB-TOTALS CU.YDS.

REG.
SUB
TOPSOIL

REG.
SUB
TOPSOIL

EXIST. RW 912.71 697+72 914.09

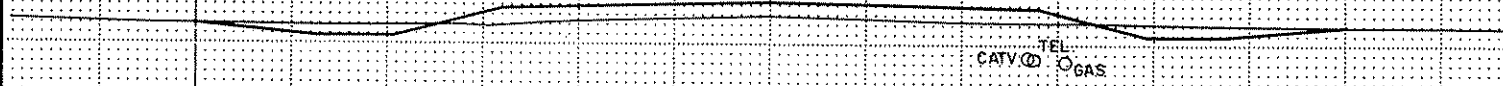

912.74 697+34 914.22



912.77 697+09 914.31

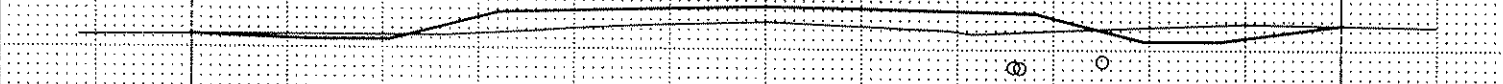

912.53 696+09 914.65

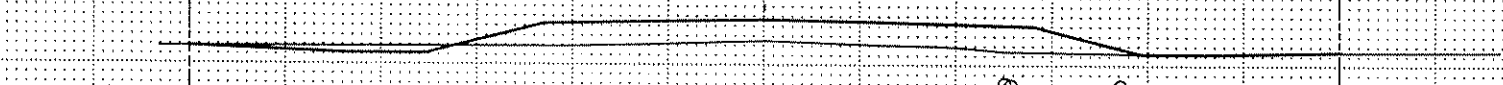

EXIST. RW 912.61 695+09 914.99

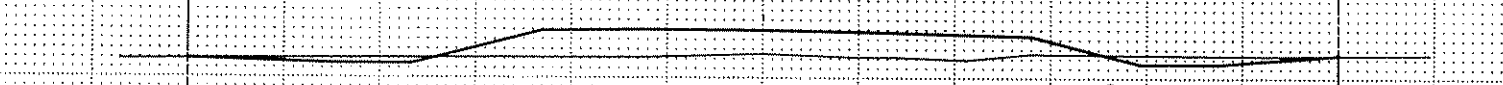

NEW RW 913.22 694+09 915.34

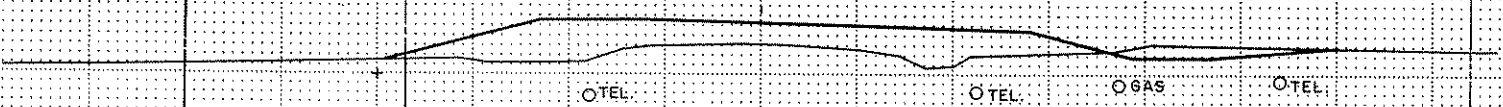

NOTE: UTILITY ELEVATIONS ASSUMED
NOT ACTUAL.

EXIST. RW 911.69 703+09 912.25

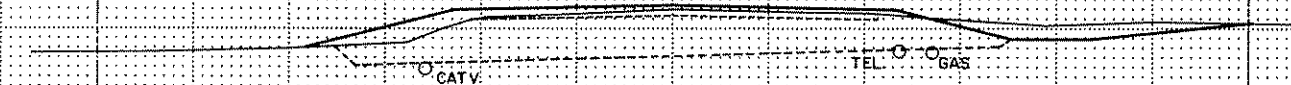

912.35 702+09 912.59

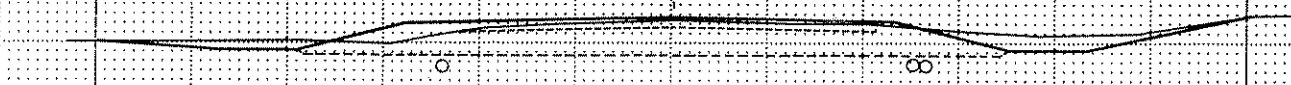

702+00
BEGIN EXTRA SUBCUT 1' B. RT. @ 10' DEEP

912.54 701+09 912.94

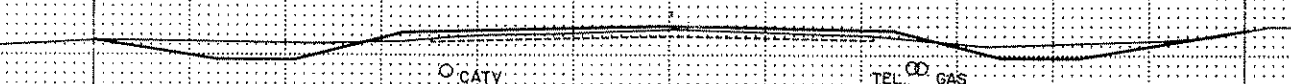

ELEC
CATV

912.82 700+09 913.28

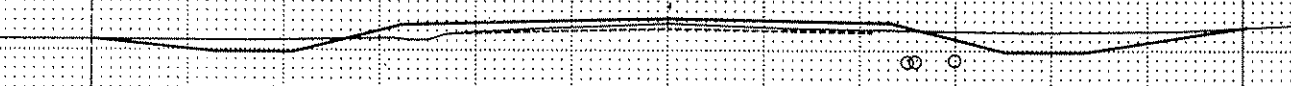

EXISTING GRADE 912.61 699+09 913.62 GRADING GRADE

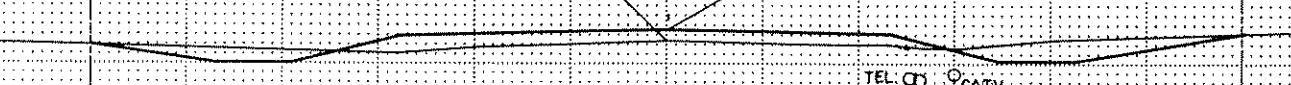

912.85 698+09 913.97

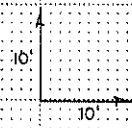
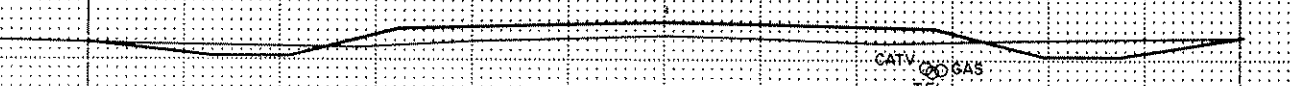

CROSS - SECTIONS
STA. 694+09 TO STA. 703+09

PLATE 3 Full Cross Section DOTTED blueprint Order Form M&B Plate 3DV

EXCAVATION EMBANKMENT
SUB-TOTALS CU.YDS. SUB-TOTALS CU.YDS.

EXCAVATION EMBANKMENT
SUB-TOTALS CU.YDS. SUB-TOTALS CU.YDS.

REG.
SUB.
TOPSOIL

REG.
SUB.
TOPSOIL

EXIST. R.W. 912.02 707+09 911.27 EXIST. R.W.

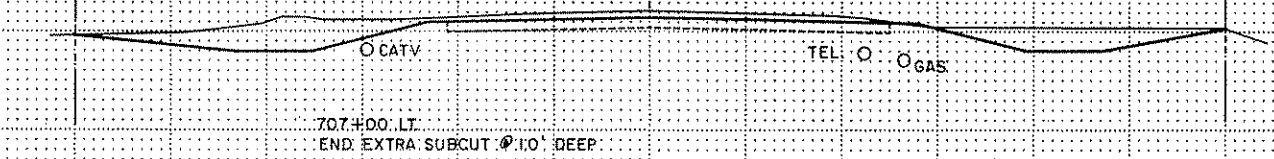

912.66 708+06 912.62 EXIST. R.W.

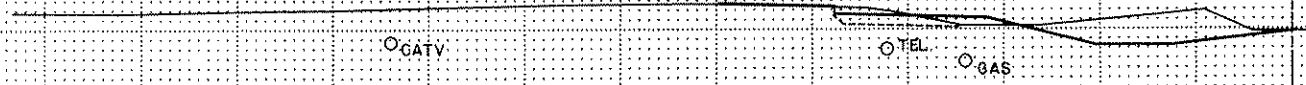

911.86 705+09 911.22

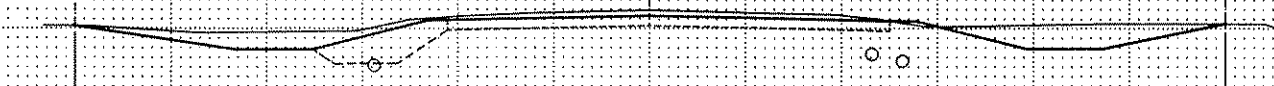

912.66 708+90 912.66

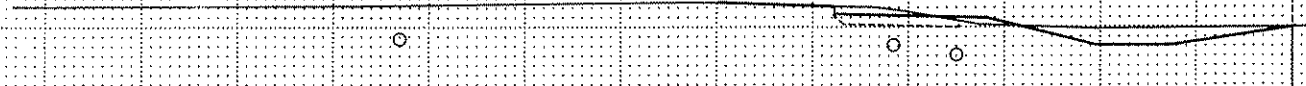

911.89 705+57 911.4

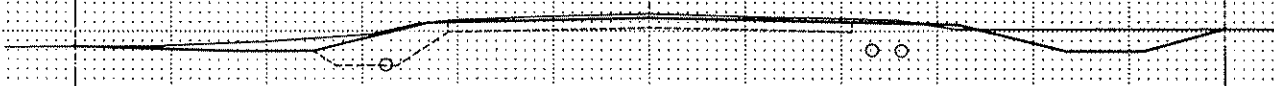

912.48 708+63 912.5

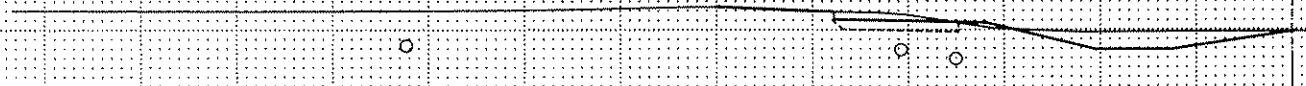

911.91 705+38 911.46 227 TH. AVE.

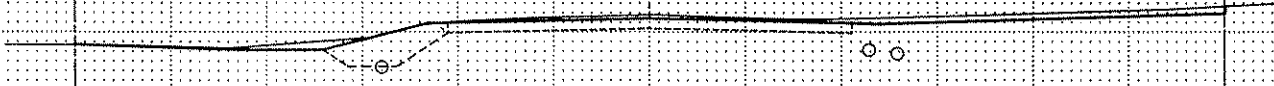

912.43 708+50 912.47

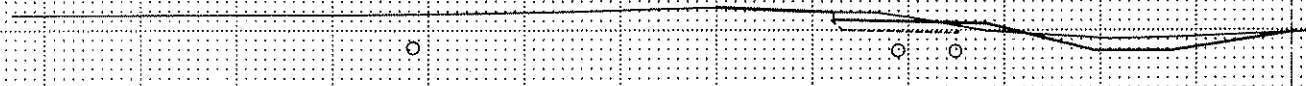

911.78 705+08 911.57 227 TH. AVE.

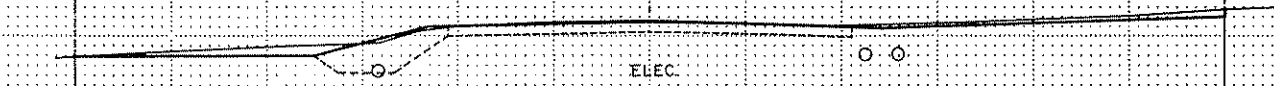

EXIST. R.W. EXISTING GRADE 912.41 708+36 912.44 GRADING GRADE

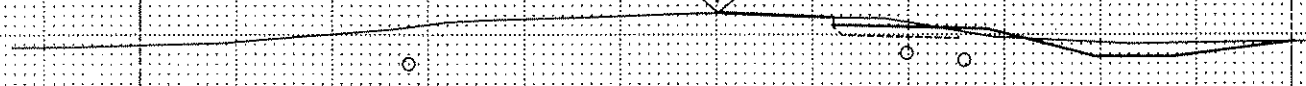

EXIST. R.W. 911.99 704+09 911.91 EXIST. R.W.

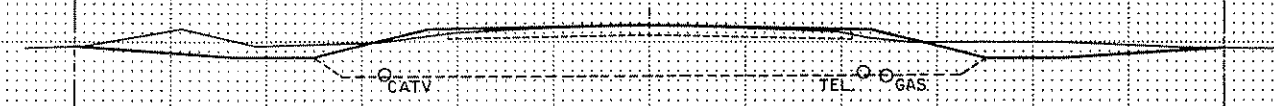

EXISTING R.W. 912.41 708+09 911.59 EXIST. R.W.

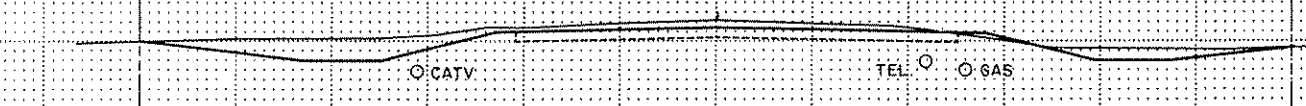

NOTE: UTILITY ELEVATIONS ASSUMED
NOT ACTUAL

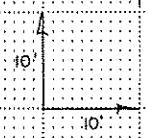

CROSS-SECTIONS
STA. 704+09 TO STA. 709+06

PLATE 3 Full Cross Section DOTTED blueprint Clear Form WMB Plate 3DV

EXCAVATION EMBANKMENT
 SUB-TOTALS CU.YDS. SUB-TOTALS CU.YDS.

REG
 SUB
 TOPSOIL

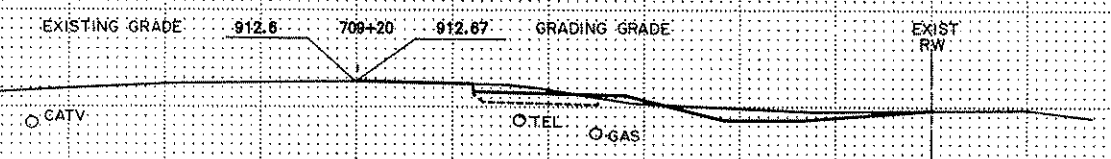
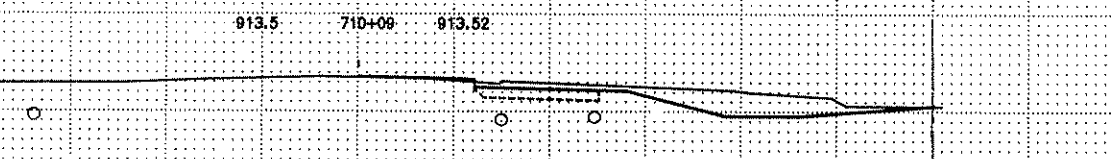
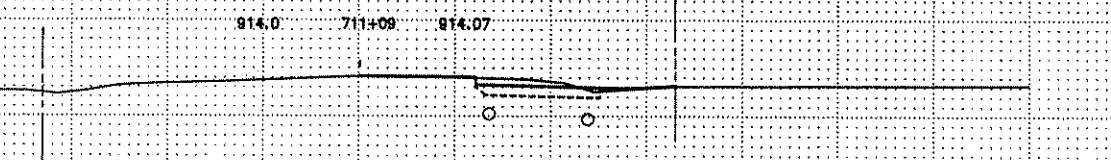
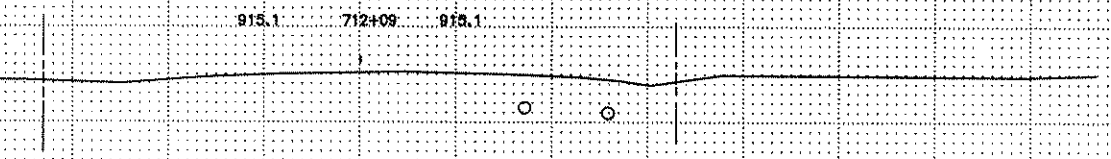
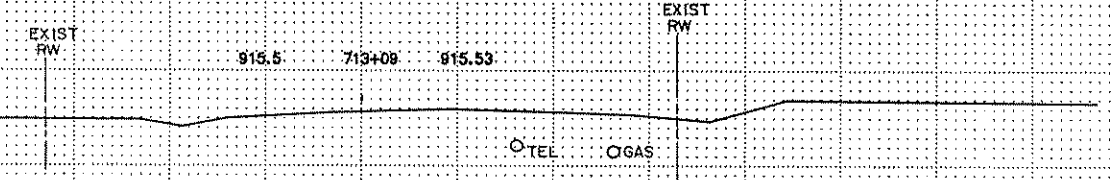

NOTE: UTILITY ELEVATIONS ASSUMED
 NOT ACTUAL

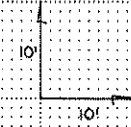

CROSS-SECTIONS
 STA. 709+20 TO STA. 713+09

PLATE 3 Full Cross Section DOTTED blueprint. Order Form MB Plate 3DV

- NOTES:**
- 1) ALL BARRICADES SHALL BE PROPERLY WEIGHTED WITH SANDBAGS.
 - 2) ALL BARRICADES SHALL HAVE REFLECTIVE MATERIAL ON BOTH SIDES.
 - 3) ALL BARRICADE MARKINGS SHALL BE SLANTED IN ACCORDANCE WITH THE MINNESOTA MANUAL ON UNIFORM TRAFFIC CONTROL DEVICES, INCLUDING THE FIELD MANUAL DATED APRIL 1995.
 - 4) ALL TRAFFIC CONTROL DEVICES SHALL CONFORM TO THE MOST RECENT EDITION OF THE MINNESOTA MANUAL ON UNIFORM TRAFFIC CONTROL DEVICES, INCLUDING THE FIELD MANUAL DATED APRIL 1995.
 - 5) ADDITIONS OR CHANGES TO THIS PLAN MAY BE MADE AS DETERMINED BY THE ENGINEER.

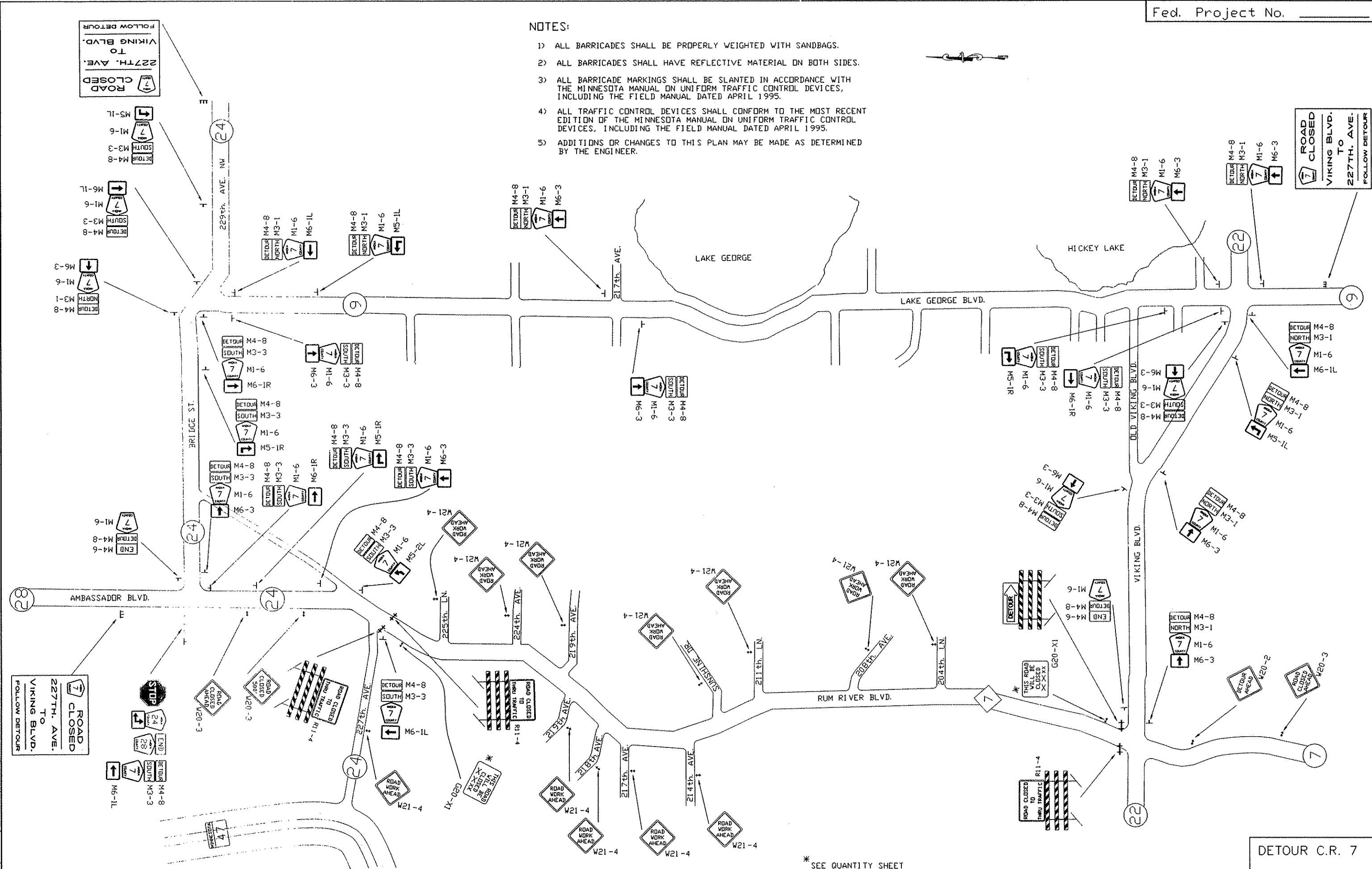

REVISIONS	DATE	BY

DETOUR C.R. 7

* SEE QUANTITY SHEET

M. U. T. C. D. CODE	SIZE	INSERT	QUANTITY
W20-2	48" x 48"		• 1
W20-3	48" x 48"		• 2 • 1
W21-4	48" x 48"		• 12
M4-10R TYPE III	48" x 18" 8 FOOT		• 1
R11-4 TYPE III	60" x 30" 8 FOOT		• 3
G20-X2	96" x 84"		• 1
G20-X2	96" x 84"		• 2
G20-X1	60" x 48"		• 2

M. U. T. C. D. CODE	SIZE	INSERT	QUANTITY	
M4-8	24" x 12"		M5-1L	• 2
M3-1	24" x 12"		M6-1L	• 2
M1-6	24" x 24"		M6-3	• 6
	21" x 15"			
M4-8	24" x 12"		M5-1L	• 1
M3-3	24" x 12"		M5-1R	• 3
M1-6	24" x 24"		M5-2	• 1
	21" x 15"		M6-1L	• 3
			M6-1R	• 3
			M6-3	• 6
M4-6	24" x 12"			
M4-8	24" x 12"			• 2
M1-6	24" x 24"			

* SIGN TO BE INSTALLED A MINIMUM OF SEVEN DAYS PRIOR TO ACTUAL CLOSING DATE OF ROAD CLOSURE AND IMPLEMENTATION OF DETOUR SIGING. SIGNS TO BE REMOVED AT TIME OF DETOUR INSTALLATION.

NOTES:

- 1) ALL BARRICADES SHALL BE PROPERLY WEIGHTED WITH SANDBAGS.
- 2) ALL BARRICADES SHALL HAVE REFLECTIVE MATERIAL ON BOTH SIDES.
- 3) ALL BARRICADE MARKINGS SHALL BE SLANTED IN ACCORDANCE WITH THE MINNESOTA MANUAL ON UNIFORM TRAFFIC CONTROL DEVICES, INCLUDING THE FIELD MANUAL DATED APRIL 1995.
- 4) ALL TRAFFIC CONTROL DEVICES SHALL CONFORM TO THE MOST RECENT EDITION OF THE MINNESOTA MANUAL ON UNIFORM TRAFFIC CONTROL DEVICES, INCLUDING THE FIELD MANUAL DATED APRIL 1995.
- 5) ADDITIONS OR CHANGES TO THIS PLAN MAY BE MADE AS DETERMINED BY THE ENGINEER.

REVISIONS	BY
DATE	DATE

QUANTITIES
DETOUR C.R. 7

CERTIFIED BY [Signature] P. E. REG NO. 20225 2/21 19 97

S. P. _____ S. A. P. _____ C. P. 94-03-07 Sheet No. 67 of 67 Sheets