

EDGE DROP OFF

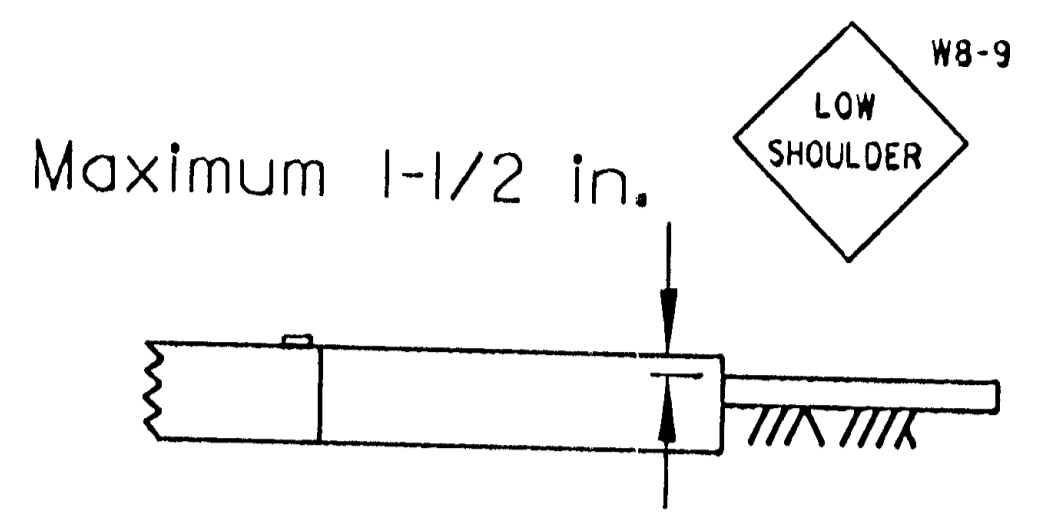

EDGE DROP OFF - WITH TAPER

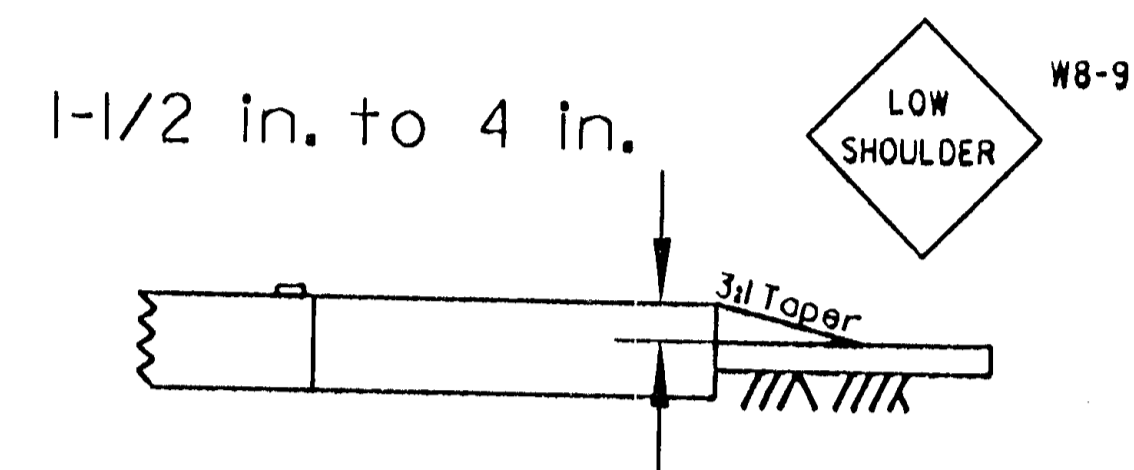

SHOULDER SHALL BE CLOSED WITH APPROPRIATE WARNING SIGNS AND CHANNELIZING DEVICES AT A MAXIMUM OF 100 FT. SPACING.

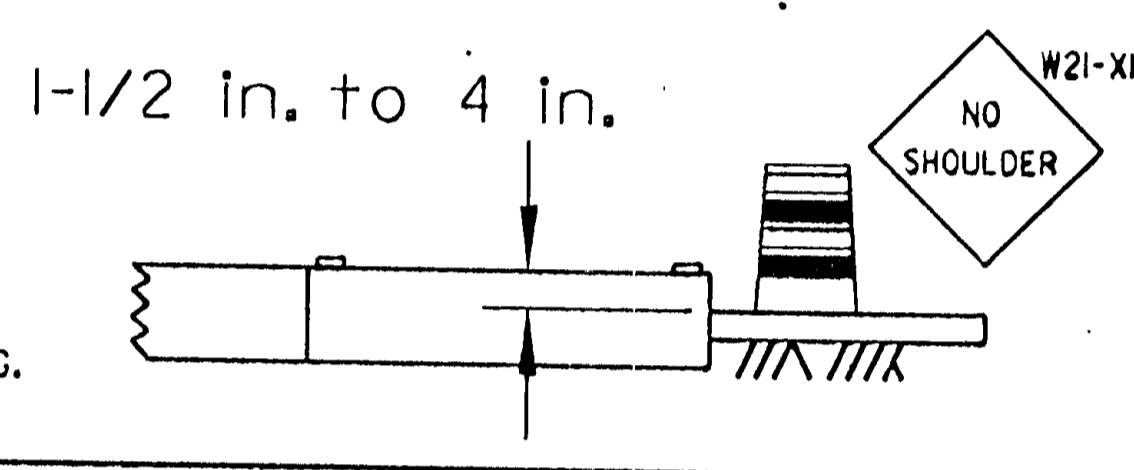

EDGE DROP-OFF WITH TAPER (SHOULDER - OPEN)

THIS CONDITION WILL NOT BE PERMITTED UNLESS THE 6:1 SLOPE IS COMPACTED SO THAT A VEHICLE MAY SAFELY DRIVE ONTO IT WITHOUT LOSING CONTROL AND IN THE OPINION OF THE ENGINEER THERE ARE NO OTHER HAZARDOUS CONDITIONS.

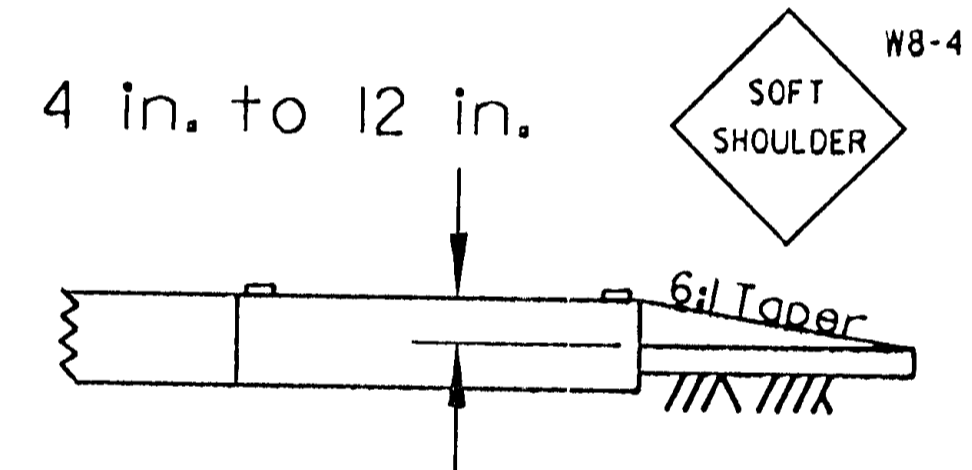

EDGE DROP-OFF WITH TAPER (SHOULDER - CLOSED)

SHOULDER SHALL BE CLOSED WITH APPROPRIATE WARNING SIGNS AND CHANNELIZING DEVICES AT A MAXIMUM OF 100 FT. SPACING

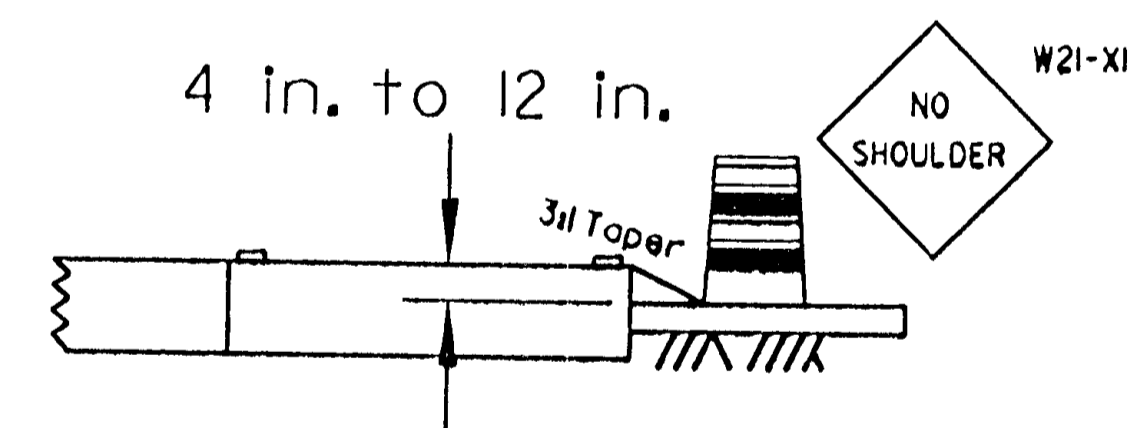

ADJACENT LANE SHALL BE CLOSED WITH APPROPRIATE LANE CLOSURE LAYOUT SHOWN IN APPENDIX B. CHANNELIZING DEVICES TO BE AT A MAXIMUM OF 100 FT. SPACING AND TYPE III EVERY 1000 FT.

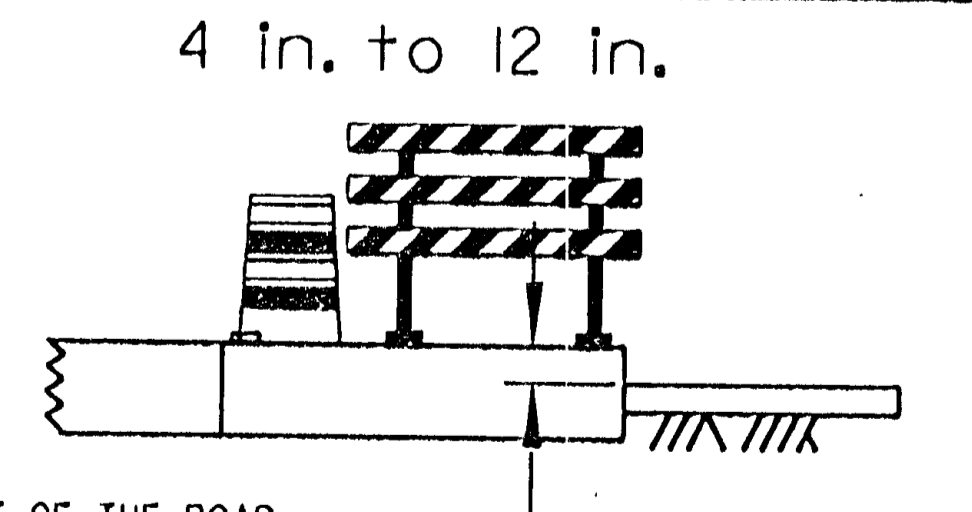

NOTE: SIGNS ARE REQUIRED ONLY ON THE SIDE OF THE ROAD THAT IS AFFECTED BY CONSTRUCTION (EXCEPT SIGNS THAT ARE FOR A LANE CLOSURE ON DIVIDED HIGHWAYS).

UNEVEN LANES

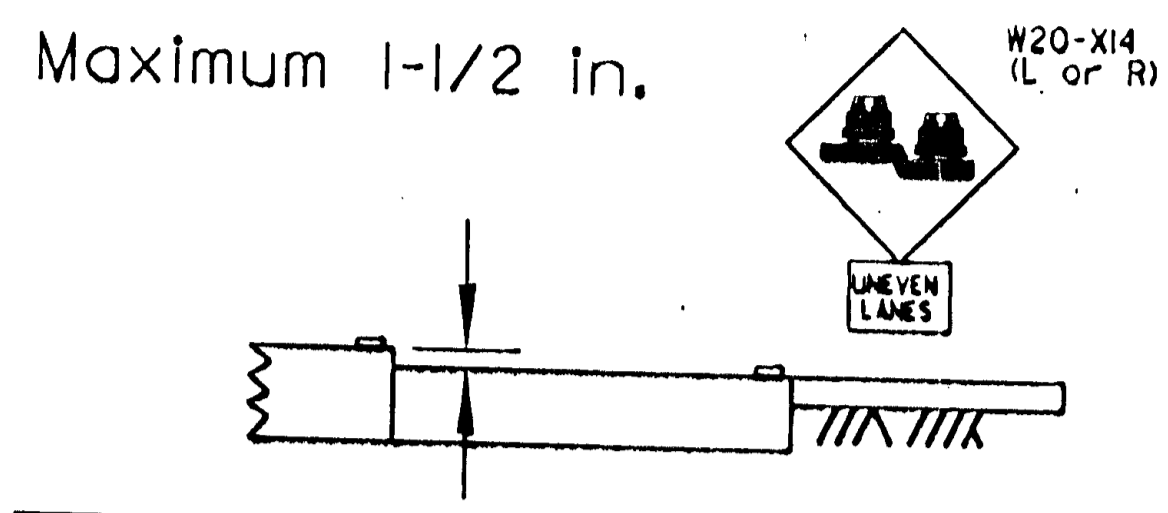

UNEVEN LANES - WITH TAPER

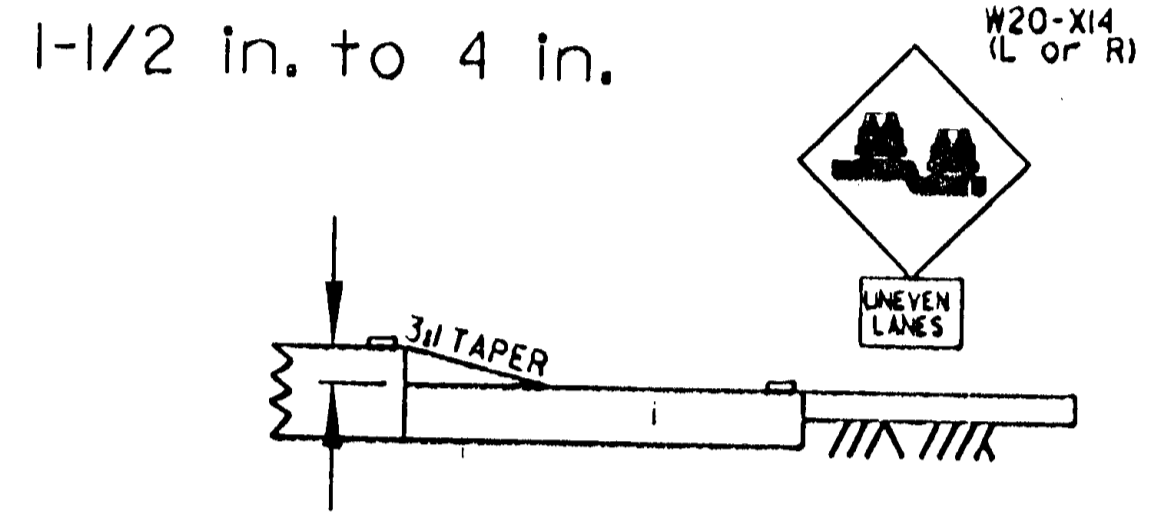

1-1/2 in. to 4 in.

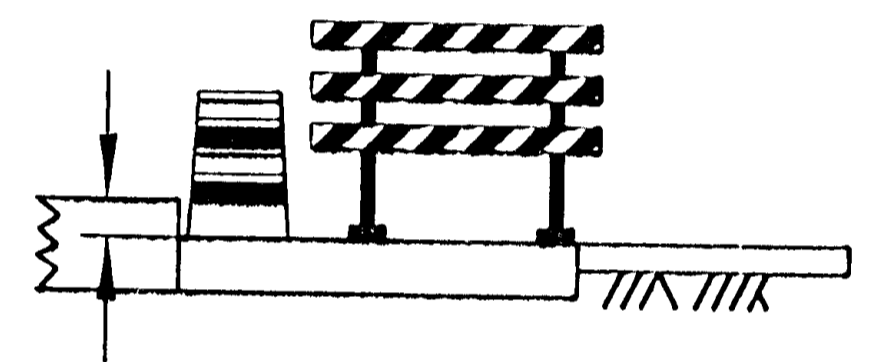

LANE SHALL BE CLOSED WITH APPROPRIATE LANE CLOSURE FROM APPENDIX B. CHANNELIZING DEVICES AT A MAXIMUM OF 100 FT. SPACING AND A TYPE III BARRICADE EVERY 1000 FT.

NOTE: FOR DIVIDED HIGHWAYS, USE SIGNS ON RIGHT AND LEFT SIDE. SIGN SEQUENCE SHOWN FOR ONE DIRECTION ONLY; OTHER DIRECTION SHALL BE IDENTICAL.

MILLED EDGE

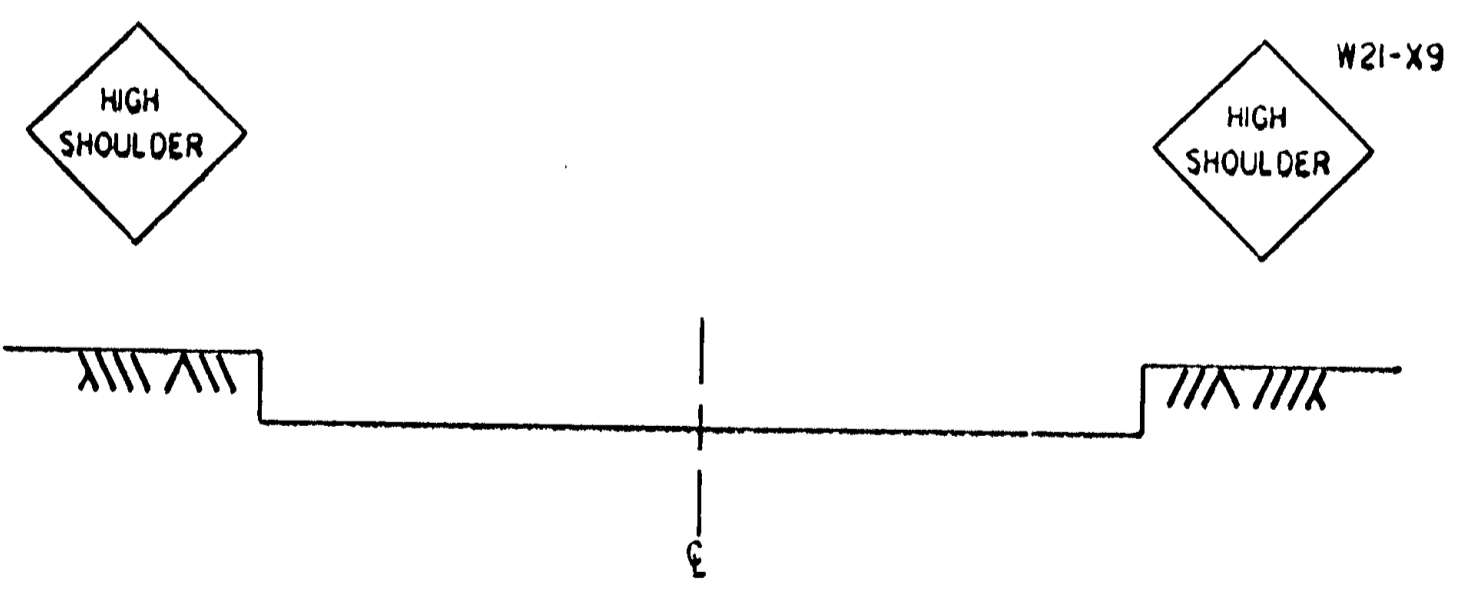

NOTE: MILLED EDGES SHOULD BE TREATED WITH TAPERS, CHANNELIZERS, AND SIGNING AS SHOWN ON EDGE DROP-OFF DETAILS.

NOTE: ALL TRAFFIC CONTROL DEVICES AND SIGNING SHALL CONFORM TO THE MINNESOTA MANUAL ON UNIFORM TRAFFIC CONTROL DEVICES, INCLUDING APPENDIX B, DATED NOVEMBER 1992.

GUIDELINES

THESE GUIDELINES ARE INTENDED TO INCREASE TRAFFIC SAFETY USING TRAFFIC CONTROL DEVICES, SAFETY RELATED APPURTENANCES, AND CONSTRUCTION TECHNIQUES FOR UNEVEN LANES, MILLED EDGES, AND EDGE DROP-OFFS THAT OCCUR IN HIGHWAY WORK ZONES. THE BEST WAY TO INCREASE TRAFFIC SAFETY IS TO MAKE EVERY ATTEMPT TO MINIMIZE EXPOSURE TO UNEVEN LANES, MILLED EDGES, AND EDGE DROP-OFFS; HOWEVER, IT IS REALIZED THAT THIS IS OFTEN NOT POSSIBLE OR FEASIBLE. ONLY WHEN UNEVEN LANES, MILLED EDGES, OR EDGE DROP-OFFS ARE DEEMED NECESSARY, SHALL THE APPROPRIATE PORTION(S) OF THESE GUIDELINES BE APPLIED TO ENHANCE TRAFFIC SAFETY.

APPROPRIATE UNEVEN LANE WARNING SIGNS OR SHOULDER WARNING SIGNS SHALL BE REPEATED AFTER EACH INTERSECTION.

MAXIMUM WARNING SIGN SPACING SHALL BE:
 A - 1 MILE WHEN THE SPEED LIMIT IS GREATER THAN 30 MPH AND
 B - 1/4 MILE WHEN THE SPEED LIMIT IS 30 MPH OR LESS.

WHEN SPACE PERMITS, MINIMUM WARNING SIGN SIZE SHALL BE:
 A - 48 INCHES x 48 INCHES WHEN THE SPEED LIMIT IS GREATER THEN 30 MPH AND
 B - 36 INCHES x 36 INCHES WHEN THE SPEED LIMIT IS 30 MPH OR LESS.

1. FOR DROP-OFFS OF 1-1/2 INCHES OR LESS, APPROPRIATE WARNING SIGNS SHALL BE PROVIDED.
2. FOR DROP-OFFS GREATER THAN 1-1/2 INCHES UP TO 4 INCHES:
 - A - THE EDGE SHALL BE TAPERED AND COMPACTED AT A RATE OF 3:1 AND APPROPRIATE WARNING SIGNS SHALL BE PROVIDED; OR
 - B - IF THE TAPER IS NOT PROVIDED, TRAFFIC SHALL NOT BE PERMITTED TO CROSS THE DROP-OFF AND THAT PORTION OF THE ROADWAY SHALL BE CLOSED TO TRAFFIC WITH THE APPROPRIATE WARNING SIGNS AND DEVICES.
3. FOR DROP-OFFS GREATER THAN 4 INCHES UP TO 12 INCHES:
 - A - THE EDGE SHALL BE TAPERED AND COMPACTED AT A RATE OF 6:1 AND APPROPRIATE WARNING SIGNS SHALL BE PROVIDED, (6:1 TAPER SHALL NOT BE USED AS A TRAFFIC CARRYING LANE);
 - B - THE EDGE SHALL BE TAPERED AND COMPACTED AT A RATE OF 3:1, TRAFFIC SHALL NOT BE ALLOWED TO CROSS THE DROP-OFF, AND THAT PORTION OF THE ROADWAY SHALL BE CLOSED TO TRAFFIC WITH APPROPRIATE WARNING SIGNS AND CHANNELIZING DEVICES; OR
 - C - IF A TAPER IS NOT PROVIDED, THE TRAFFIC OR AUXILIARY LANE ADJACENT TO THE DROP-OFF SHALL BE CLOSED TO TRAFFIC WITH THE APPROPRIATE WARNING SIGNS AND CHANNELIZING DEVICES OR A POSITIVE BARRIER, SUCH AS A PORTABLE PRECAST CONCRETE BARRIER, SHALL BE PROVIDED TO PREVENT TRAFFIC FROM CROSSING THE DROP-OFF.
4. FOR SHOULDER EDGE DROP-OFFS:
 - A - 0-2 FOOT SHOULDER WIDTH AND A 0-12 INCH DROP-OFF; USE GUIDELINES AS SHOWN
 - B - 2-8 FOOT SHOULDER WIDTH AND A 0-4 INCH DROP-OFF; INSTALL EDGELINE OR USE GUIDELINES AS SHOWN
 - C - 8 FOOT OR GREATER SHOULDER WIDTH AND A 0-4 INCH DROP-OFF; NO TRAFFIC CONTROL REQUIRED
 - D - GREATER THAN 2 FOOT SHOULDER WIDTH AND A 4-12 INCH DROP-OFF; USE GUIDELINES AS SHOWN
5. DROP-OFFS GREATER THAN 4 INCHES ADJACENT TO TRAFFIC CARRYING LANES ARE PERMITTED WITHOUT TAPERS OR POSITIVE BARRIERS FOR:
 - A - PROJECTS WITHIN URBAN AREA WHEN THE SPEED LIMIT IS 30 MPH OR LESS; OR
 - B - SHORT TERM (7 CALENDAR DAYS OR LESS) CONCRETE OR UTILITY REPAIR, LESS THAN 50 FEET IN LENGTH WHEN THE SPEED LIMIT IS GREATER THAN 30 MPH.
6. AT NO TIME SHALL THERE BE MORE THAN ONE UNEVEN LANE CONDITION BETWEEN THE TRAFFIC CARRYING LANES WHICH INCLUDE AUXILIARY LANES, TURN LANES, AND RAMP ACCESS OR EGRESS AREAS. WEATHER PERMITTING, ALL EXPOSED UNEVEN LANES CONDITIONS WITHIN THE TRAFFIC CARRYING LANES SHALL BE 'MATCHED' WITHIN 24 HOURS.
7. MILLING OPERATIONS SHALL BE REQUIRED TO COMPLETE THE FULL WIDTH OF THE SECTION UNDER CONSTRUCTION AT THE END OF EACH WORK PERIOD.

Traffic Control Treatment of Longitudinal Joints and Edge Drop-offs in Work Zones

VAX780 OSA3:145,1001 FILE NAME LANEDGE.DGN