

TYPICAL SECTION

Ⓐ STATION 184+04 TO STATION 404+76

Ⓑ STATION 404+76 TO STATION 601+97

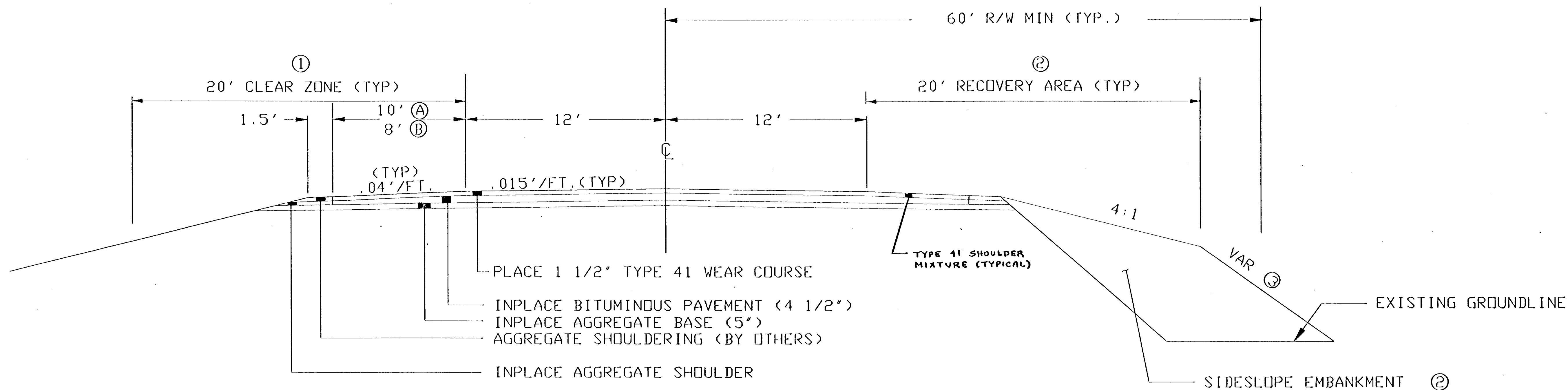

NOTES:

- ⓐ PROVIDE OBSTACLE-FREE AREA WITHIN THIS ZONE. SEE CHART D FOR MISCELLANEOUS REMOVALS.
- ⓑ PROVIDE A 4:1 SHOULDER INSLOPE WITHIN RECOVERY AREA. SEE CHART C FOR EMBANKMENT REQUIREMENTS.
- ⓒ 3:1 MAXIMUM

TYPICAL SECTION

REVISIONS			
DATE	BY	DATE	BY