

PLAN SYMBOLS

COUNTY LINE	---
TOWNSHIP OR RANGE LINE	---
SECTION LINE	---
QUARTER LINE	---
SIXTEENTH LINE	---
RIGHT OF WAY LINE	---
SLOPE (EASEMENT)	---
PRESENT RIGHT OF WAY	---
PROPERTY LINE	---
CORPORATE OR CITY LIMITS	---
RETAINING WALL	---
RAILROAD	---
RAILROAD RIGHT OF WAY	---
RIVER OR CREEK	---
DRAINAGE DITCH	---
CULVERT	---
DROP BUILT	---
GALENE RAIL	---
BARBED WIRE FENCE	---
WOODEN WIRE FENCE	---
CHAIN LINK FENCE	---
WOOD FENCE	---
STONE WALL ON FENCE	---
WEDGE	---

LOWLAND	---
TIMBER	---
ORCHARD	---
BIROSE	---
MURSEBY	---
GATE CULVERT	---
OVERPASS (Highway Over)	---
UNDERPASS (Highway Under)	---
BRIDGE	---
BUILDINGS (One Story Frame)	---
F-FRAME C-CORNER	---
S-STEEL T-PILE	---
R-BRICK ST-STRUCK	---
RAILROAD CROSSING BELL	---
RAILROAD CROSSING GATE	---
MANSION	---
CATCH BASIN	---
FIRE HYDRANT	---
CAST IRON MONUMENT	---
IRON PIN	---
GRAVEL PIT	---
SAND PIT	---
BORROW PIT	---
ROCK CHIPPY	---

UTILITY SYMBOLS

POWER POLE LINE	---
TELEPHONE OR TELEGRAPH POLE LINE	---
JOINT TELEPHONE & POWER ON POWER POLES	---
ONE TELEPHONE POLES	---
ANCHOR	---
STREET LIGHT	---
STREET LIGHT	---
PEDISTAL (Cable Terminal)	---
GAS MAIN	---
WATER MAIN	---
TELEPHONE CABLE IN CONDUIT	---
ELECTRIC CABLE IN CONDUIT	---
TELEPHONE MANHOLE	---
ELECTRIC MANHOLE	---
TURBID TELEPHONE CABLE	---
BURIED ELECTRIC CABLE	---
AERIAL TELEPHONE CABLE	---
SEWER (Sanitary or Storm)	---
SEWER MANHOLE	---

SCALES

PLAN	0 5m 10m 20m
PROFILE HORIZONTAL	0 5m 10m 20m
VERTICAL	0 0.5m 1m 2m
X-SECTIONS HORIZONTAL	0 1m 2m 4m
VERTICAL	0 1m 2m 4m
INDEX MAP	0.5km 1km 2km

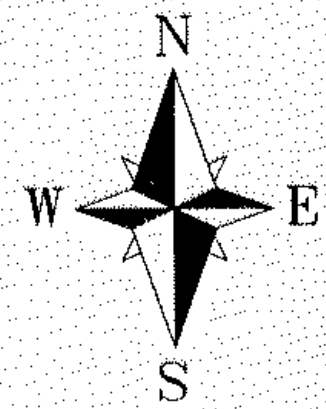

MINNESOTA DEPARTMENT OF TRANSPORTATION

ANOKA COUNTY

CONSTRUCTION PLAN FOR GRADING, DRAINAGE, AGGREGATE BASE, BITUMINOUS SURFACING, CURB & GUTTER, SIGNAL SYSTEMS, CONCRETE WALK, AND BITUMINOUS PATH.

LOCATED ON C.S.A.H. 1 FROM C.S.A.H. 8 (OSBORNE RD) TO MISSISSIPPI BLVD in the cities of Fridley and Coon Rapids (Geographic Description)

STATE PROJ. NO. 02-601-37

C.S.A.H. 1

GROSS LENGTH	2095.000 METERS	2.095 KILOMETERS
BRIDGES-LENGTH	0.000 METERS	0.000 KILOMETERS
EXCEPTIONS-LENGTH	0.000 METERS	0.000 KILOMETERS
NET LENGTH	2095.000 METERS	2.095 KILOMETERS

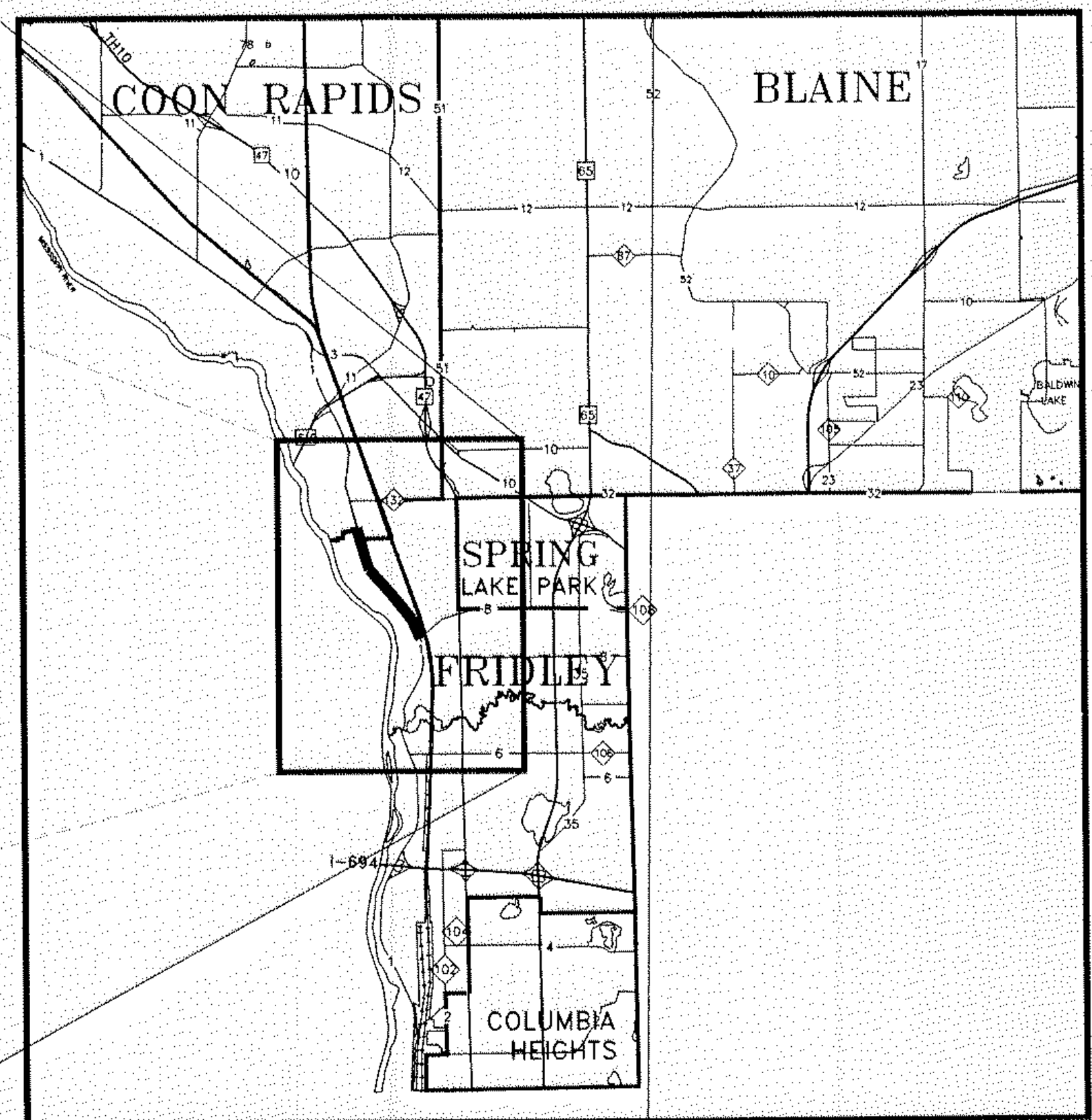
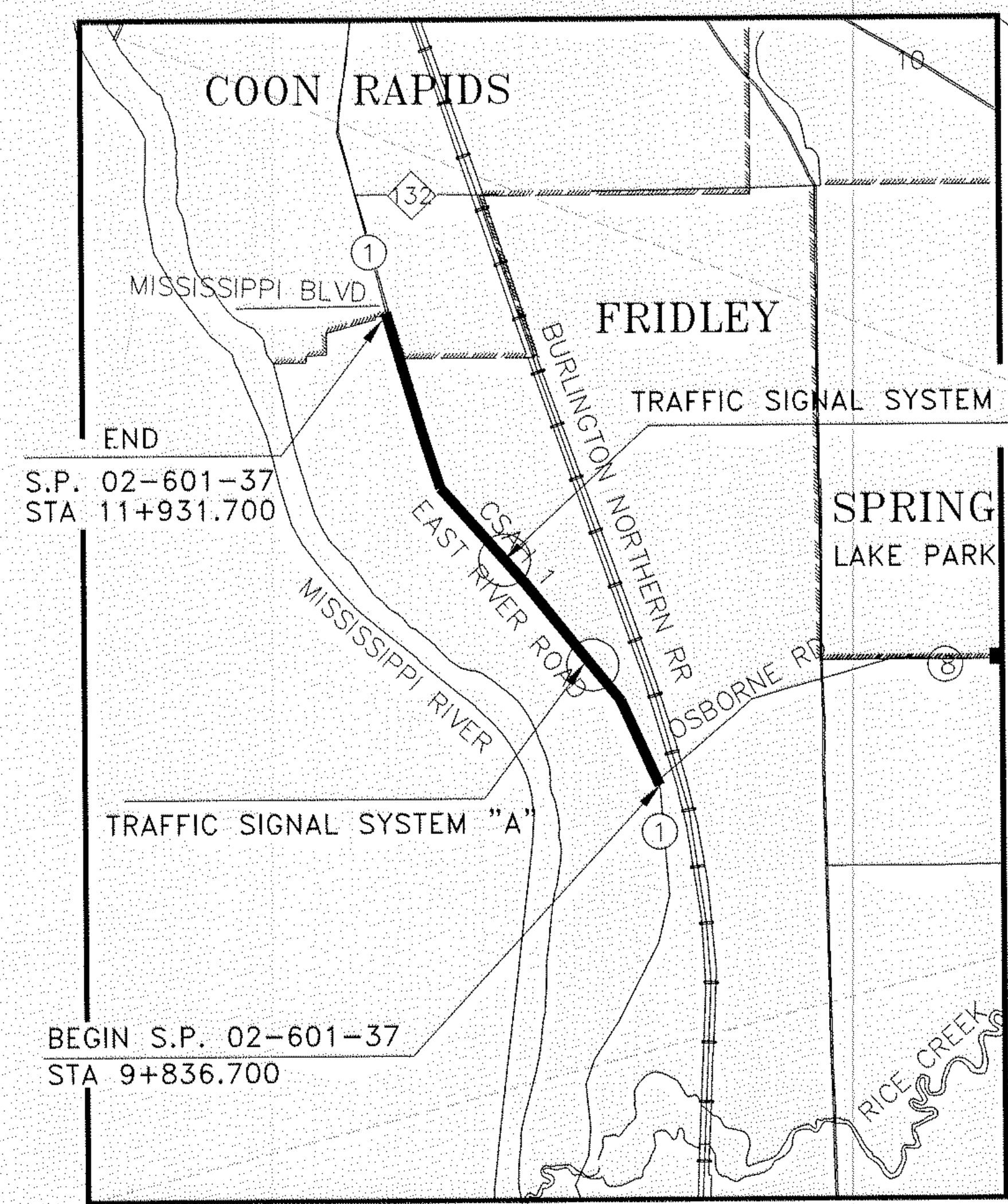

MINN. PROJ. NO. STP 0298 (123)

GOVERNING SPECIFICATIONS

THE 1995 EDITION OF THE MINNESOTA DEPARTMENT OF TRANSPORTATION "STANDARD SPECIFICATIONS FOR CONSTRUCTION" SHALL GOVERN. ALL TRAFFIC CONTROL DEVICES SHALL CONFORM TO THE MMUTCD, INCLUDING "FIELD MANUAL FOR TEMPORARY TRAFFIC CONTROL ZONE LAYOUTS - JANUARY 1998."

INDEX

SHEET NO.	DESCRIPTION
1	TITLE SHEET
2 - 3	STATEMENT OF ESTIMATED QUANTITIES
4 - 8	TABULATION CHARTS
9	STANDARD DETAILS PLAN
10	EARTHWORK SUMMARY / PAVEMENT CHART
11 - 12	EROSION CONTROL DETAILS
13	TYPICAL SECTIONS
14	ALIGNMENT PLANS
15	ALIGNMENT TABULATION CHARTS
16 - 18	EXISTING CONDITION AND REMOVAL PLAN
19	SUPERELEVATION CHART
20 - 25	CONSTRUCTION PLAN AND PROFILE
26 - 37	DRAINAGE PLAN AND TABULATION
38 - 59	CROSS-SECTION
60 - 61	DETOUR LAYOUT AND TAB.
62 - 68	SIGNING AND STRIPING PLANS
69 - 80	TRAFFIC SIGNAL SYSTEMS
81 - 93	TRAFFIC CONTROL PLANS

THIS PLAN CONTAINS 93 SHEETS

DESIGN DESIGNATION

ESAL ₂₀	3 968 553
R VALUE	50
ADT (1998) =	20 516
Proj. ADT (2018) =	34 877
Proj. HCADT (2018) =	2 616
Soil Factor	NA
8.2	METRIC TON DESIGN

Functional Classification ARTERIAL HIGH DENSITY
 No. of Traffic Lanes 4 No. of Parking Lanes 0
 Design Speed 80 Km/h
 Based on: Stopping Sight Distance
 Height of eye 1070 mm Height of object 150 mm
 Design Speed not achieved at:
 STA. TO STA. MPH
 STA. TO STA. MPH

BIKE PATH DESIGN DESIGNATION BLOCK

Design Speed 30 Km/h
 Based on: Stopping Sight Distance
 Height of eye 1400 mm Height of object 0 mm

Approved	,19	ANOKA COUNTY ENGINEER	Date
Approved	,19	CITY OF COON RAPIDS ENGINEER	Date
Approved	,19	CITY OF FRIDLEY ENGINEER	Date
Metro Division State Aid Engineer: Reviewed for Compliance with State and Federal Aid Rules/Policy			Date
Approved for State and Federal Aid Funding: State Aid Engineer			Date

NO.	DATE	BY	CKD	APPR	REVISION

I HEREBY CERTIFY THAT THIS PLAN WAS PREPARED BY ME OR UNDER MY DIRECT SUPERVISION AND THAT I AM A DULY REGISTERED PROFESSIONAL ENGINEER UNDER THE LAWS OF THE STATE OF MINNESOTA.

DATE REG. NO.

DRAWN BY	DATE
DESIGN BY	DATE
CHECKED BY	DATE

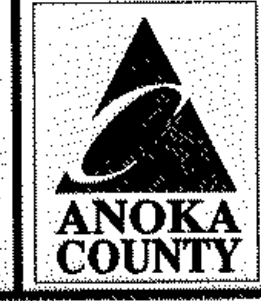

ANOKA COUNTY
HIGHWAY DEPT.

STATE PROJECT NO.	02-601-37
STATE PROJECT NO.	127-020-20
STATE PROJECT NO.	114-020-18
COUNTY PROJECT NO.	

TITLE SHEET
Sheet 1 of 93 Sheets

MAIL BOX SALVAGE AND INSTALL (I)

Table with 5 columns: STATION, ADDRESS, LOC., DESCRIPTION, EACH. Lists 16 items for mail box salvage and installation.

REMOVE RETAINING WALL (M)

Table with 4 columns: STATION - STATION, LOC., REMARKS, m. Lists 10 items for removing retaining walls.

REMOVE BITUMINOUS FLUME (J)

Table with 4 columns: STATION TO STATION, DESCRIPTION, REMARKS, EACH. Lists 8 items for removing bituminous flume.

SALVAGE GUARDRAIL (N)

Table with 4 columns: STATION - STATION, LOC., REMARKS, m. Lists 1 item for salvaging guardrail.

REMOVE CONCRETE PAVEMENT (K)

Table with 4 columns: STATION - STATION, LOCATION, REMARKS, m². Lists 3 items for removing concrete pavement.

SILT FENCE LOCATION (O)

Table with 6 columns: STATION - STATION, LOCATION, REMARKS, m, m. Lists 5 items for silt fence locations.

SANITARY SEWER MODIFICATIONS (P)

Large table with 15 columns: STATION, LOCATION, INPL., EXISTING SAN. SEWER (INPLACE TOP ELEV., PROP. TOP ELEV., ADJUST. EACH, RECONST. m), DESIGN, TOP CAST ELEV., INVERT ELEV., PAY HT. m, NEW CONST. (F. & I. CASTING ASSEMBLY, F. & I. GATE VALVE, F. & I. 150mm TEE, F. & I. 150mm PLUG), REMARKS. Lists 30 items for sanitary sewer modifications.

CONSTRUCT CONCRETE WALK (R)

Table with 9 columns: STATION TO STATION, LOC., DESCRIPTION, 100mm m², 125mm m², 150mm m², 200mm REINFORCED m². Lists 50 items for constructing concrete walks.

SANITARY CASTING SCHEDULE (Q)

Table with 6 columns: ASS'Y TYPE, NO., REQ'D., FRAME CASTING, GRATE CASTING, RING CASTING, COVER CASTING. Lists casting schedule details.

TABULATION CHARTS

MAIL BOX SALVAGE AND INSTALL
REMOVE BITUMINOUS FLUME
REMOVE CONCRETE PAVEMENT
REMOVE RETAINING WALL
SALVAGE GUARDRAIL
SILT FENCE LOCATION
SANITARY SEWER MODIFICATION
SANITARY CASTING SCHEDULE
CONSTRUCT CONCRETE WALK

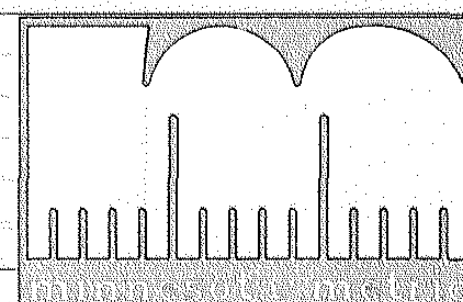

I HEREBY CERTIFY THAT THIS PLAN WAS PREPARED BY ME OR UNDER MY DIRECT SUPERVISION AND THAT I AM A DULY REGISTERED PROFESSIONAL ENGINEER UNDER THE LAWS OF THE STATE OF MINNESOTA.

DRAWN BY _____ DATE _____
DESIGN BY _____ DATE _____
CHECKED BY _____ DATE _____



ANOKA COUNTY HIGHWAY DEPT.

STATE PROJECT NO. 02-601-37
STATE PROJECT NO. 127-020-20
STATE PROJECT NO. 114-020-18
COUNTY PROJECT NO. _____

TABULATION CHARTS

PASSENGER SHELTER PAD

FOR LOCATION SEE CHART R

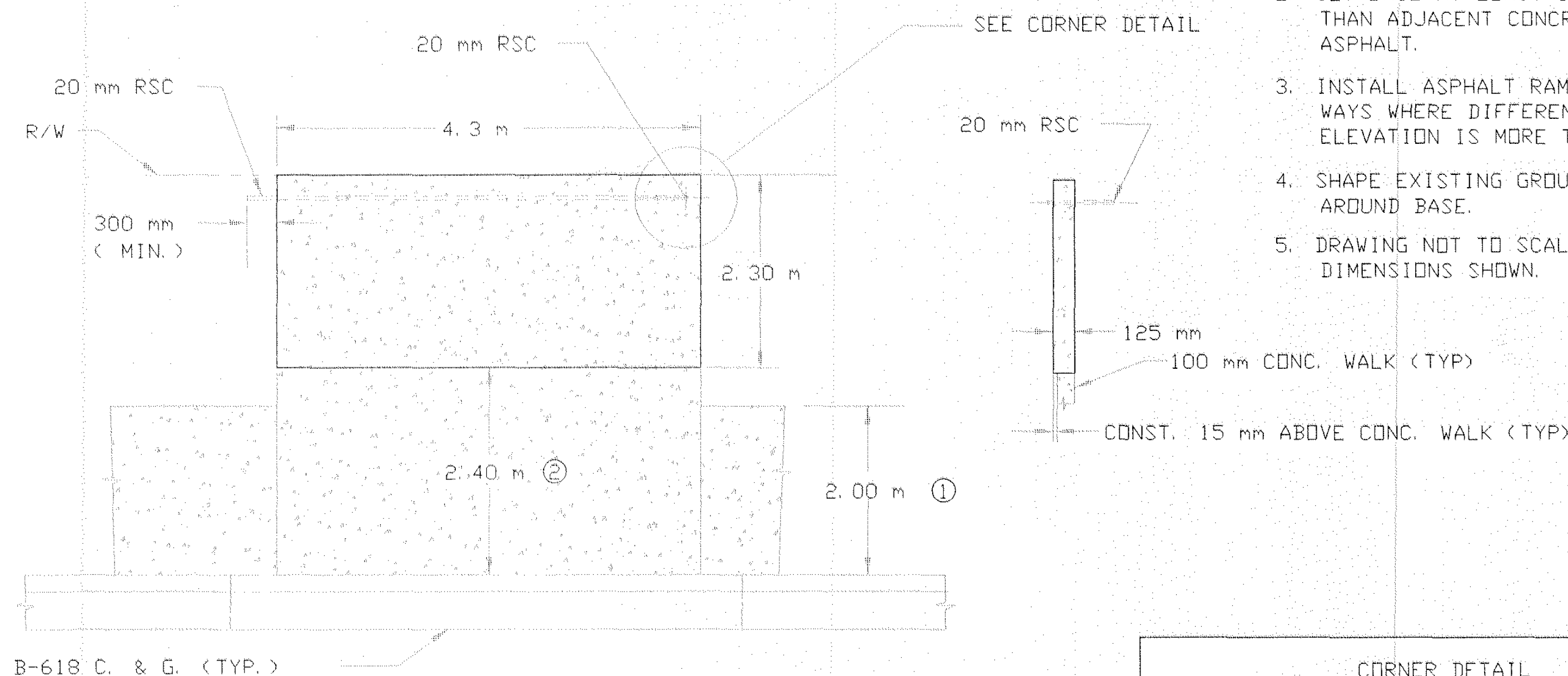

- NOTES:
1. SAWCUT OPENINGS IN EXISTING CONCRETE OR ASPHALT 38 mm WIDER THAN CAST-IN-PLACE SLAB ON ALL SIDES.
 2. SET BASE AT LEAST 13 mm HIGHER THAN ADJACENT CONCRETE OR ASPHALT.
 3. INSTALL ASPHALT RAMP AT DOORWAYS WHERE DIFFERENCE IN ELEVATION IS MORE THAN 13 mm
 4. SHAPE EXISTING GROUND TO DRAIN AROUND BASE.
 5. DRAWING NOT TO SCALE - USE DIMENSIONS SHOWN.

B-618 C. & G. (TYP.)

1. BOARDING PADS TO BE 2.00 m X 20.00 m (EXCEPT WHERE R/W PROHIBITS)
2. OPTIMUM CONDITION EXCEPT WHERE R/W PROHIBITS

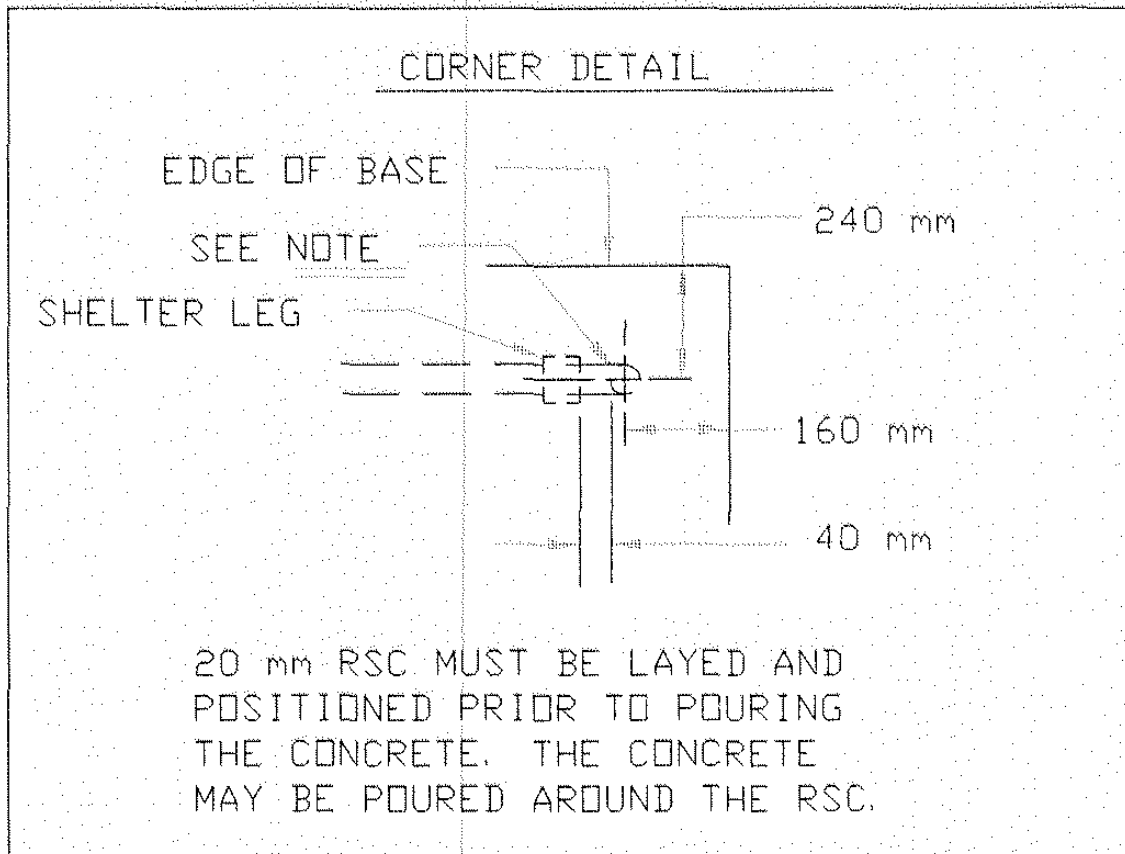
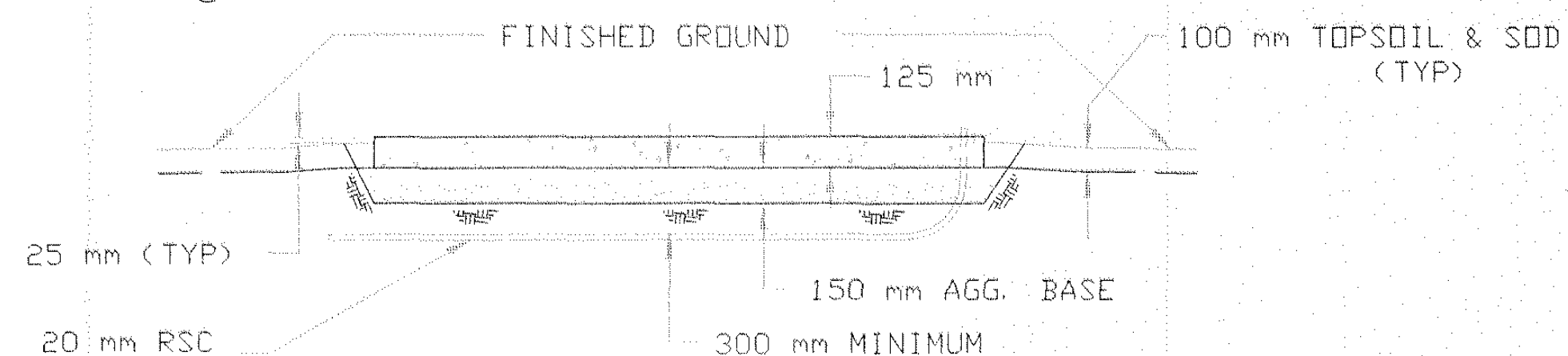

WATERMAIN CROSSING DETAIL

PLAN VIEW
STA. 9+868.30 TO STA. 9+886.60

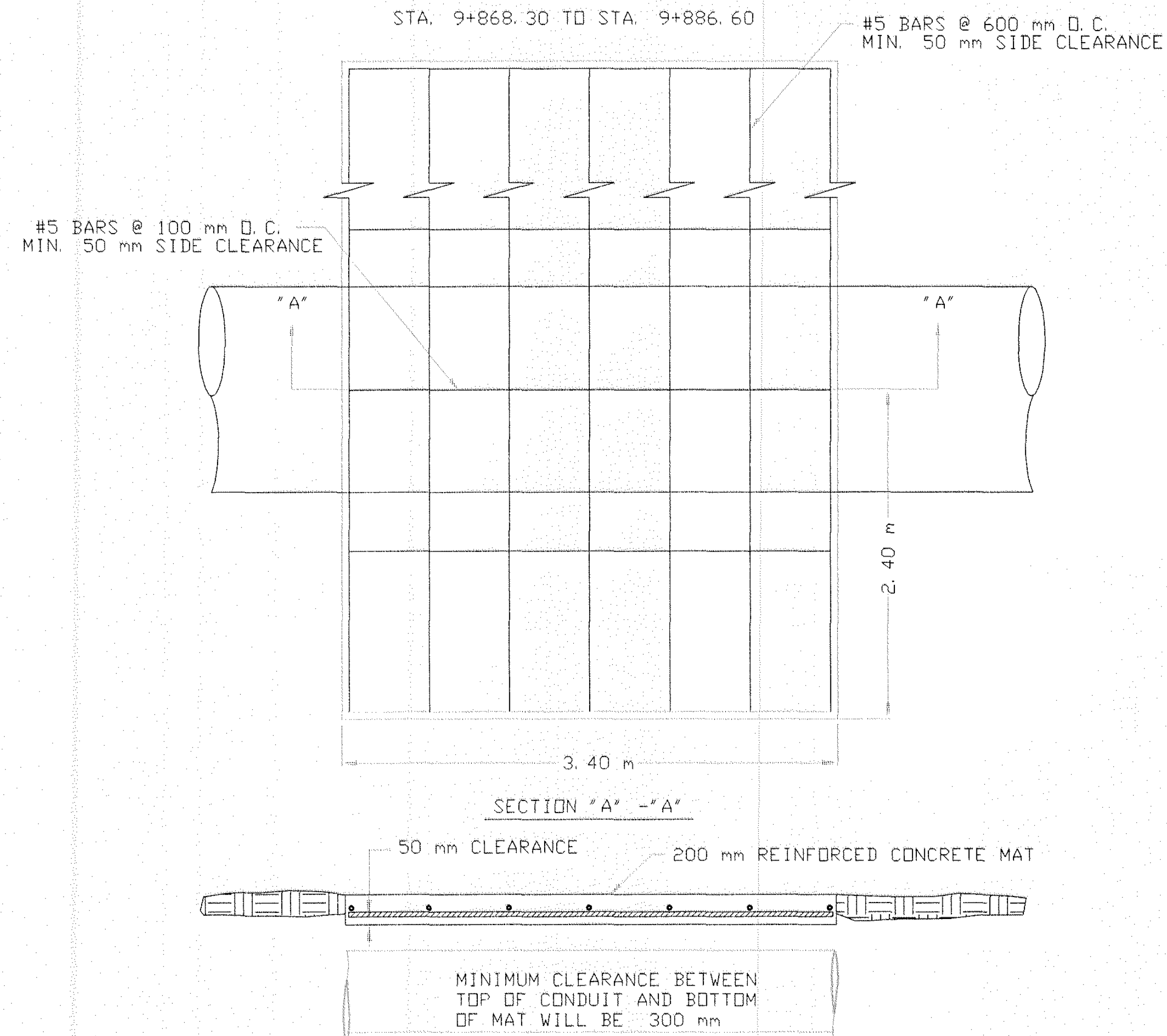

MODULAR BLOCK RETAINING WALL DETAIL

FOR LOCATION SEE CHART AA

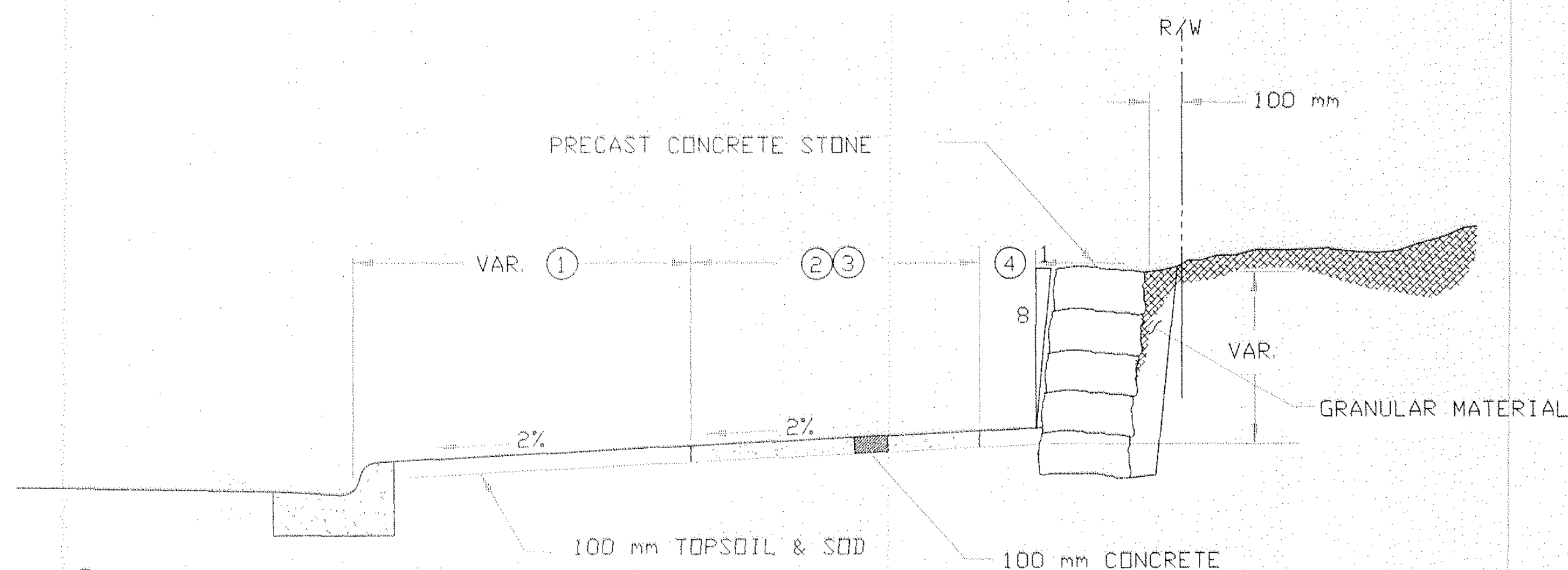

1. SEE PLANS AND X-SECTION FOR BOULEVARD WIDTHS.
2. 1.50 m CONC. SIDEWALK OR 3.0 m BIT. BIKE PATH
3. SEE TYPICAL SEC. FOR LOC. SPECIAL SLOPE
4. 0.50 m MIN. CLEAR ZONE ADJ. TO BIT. PATH, 0.45 m MIN. ADJ. TO 1.5 m CONCRETE WALK

CONCRETE ENCASED CASTING

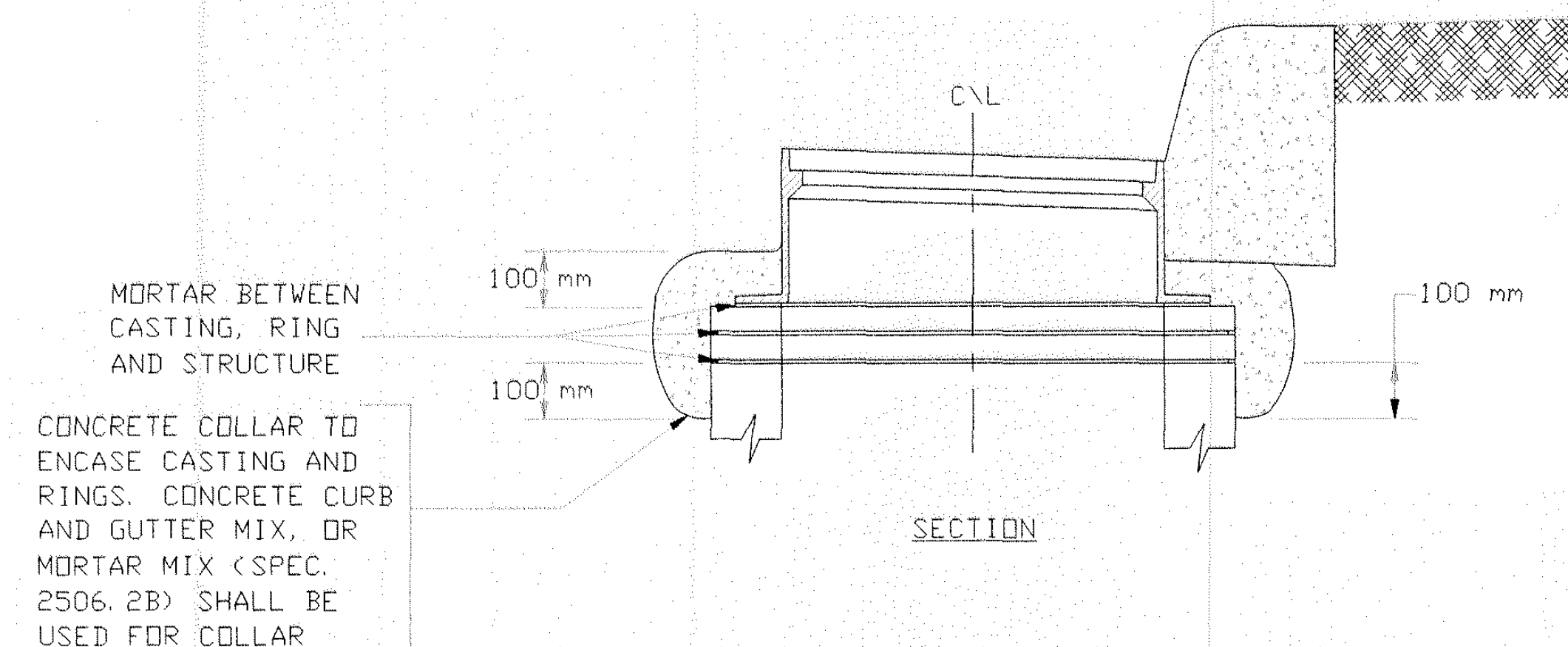

NO	DATE	BY	CKD	APPR	REVISION

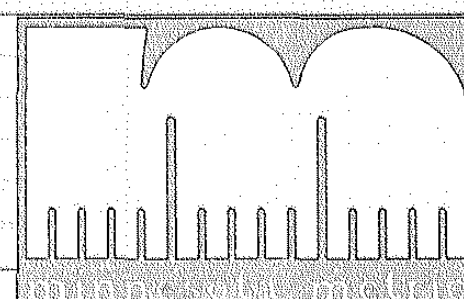

I HEREBY CERTIFY THAT THIS PLAN WAS PREPARED BY ME OR UNDER MY DIRECT SUPERVISION AND THAT I AM A DULY REGISTERED PROFESSIONAL ENGINEER UNDER THE LAWS OF THE STATE OF MINNESOTA.

DRAWN BY: MN DATE 03/04/99
 DESIGN BY: KGJ DATE 03/04/99
 CHECKED BY: LR DATE 03/04/99

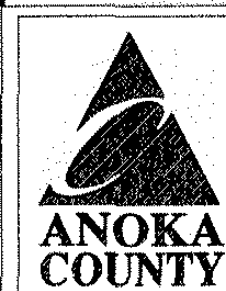

ANOKA COUNTY
HIGHWAY DEPT.

STATE PROJECT NO. 02-601-37
 STATE PROJECT NO. 127-020-20
 STATE PROJECT NO. 114-020-18
 COUNTY PROJECT NO.

STANDARD DETAILS
PLAN

EARTHWORK SUMMARY

BALANCE

Fed. Project No.

EXCAVATION

EMBANKMENT (CV)

COMMON EXCAVATION . . .53 287 m3
REGULAR 30 140 m3
SUBCUT 15 049 m3
TOPSOIL 8 098 m3
COMMON EXCAVATION . . .53 287 - 7 874 = 45 413 m3 (PAY ITEM)

EMBANKMENT (REG.) . . . 9 245 m3
SUBCUT 15 049 m3
TOPSOIL 8 889 m3

TOPSOIL
[TOPSOIL STRIPPING (EV) x SHRINKAGE FACTOR] - TOPSOIL DRESSING (CV) FACTOR] = EXCESS (+) OR SHORTAGE (-)
(8 098 x 0.80) - 8 889 = - 2 411 m3 SHORTAGE (CV). (SEE NOTE 22.)

EMBANKMENT MATERIAL
[(REG. EXCAVATION (EV) - REMOVALS) x SHRINKAGE FACTOR] + [SUBCUT x SHRINKAGE FACTOR] - [REG. EMBANKMENT (CV) + SUBCUT] = SHORTAGE (-) OR EXCESS (+).
[(30 140 - 7 874) x 0.80] + (15 049 x 0.80) - [9 245 + 15 049] = + 5 558 m3 EXCESS (CV)

SOIL FACTORS:
(1) REGULAR GRADING AND TOPSOIL DRESSING (EV TO CV): 80% SHRINKAGE
(2) SUBCUT COMPACTION (EV TO CV): 90% SHRINKAGE
(3) SELECT GRANULAR BORROW (CV TO LV): 120% SWELL
(4) TOPSOIL BORROW (CV TO LV): 120% SWELL

INCLUDES 7 874 m3 OF BITUMINOUS AND CONC. PAVEMENT REMOVALS (SEE REMOVAL CHARTS FOR PAY ITEMS.)

SOILS AND CONSTRUCTION NOTES:

- 1. TOP OF GRADING GRADE IS DEFINED AS THE BOTTOM OF THE AGGREGATE BASE.
2. IN FILL AREAS, THE SUBGRADE SHALL BE CONSTRUCTED WITH SELECTED GRADING MATERIAL.
3. SELECTED GRADING MATERIALS SHALL CONSIST OF SELECT GRANULAR MATERIALS.
4. GRANULAR MATERIAL, REGARDLESS OF SOURCE, SHALL MEET THE REQUIREMENTS OF SPEC. 3149.2B.
5. COMPACTION OF THE GRADING PORTION OF THIS PROJECT SHALL BE BY THE "SPECIFIED DENSITY METHOD".
6. TEST ROLLING WILL NOT BE REQUIRED.
7. BITUMINOUS OR CONCRETE ITEMS REMOVED BY CONSTRUCTION SHALL BECOME THE PROPERTY OF THE CONTRACTOR AND SHALL BE EITHER RECYCLED OR DISPOSED OF IN ACCORDANCE WITH THE REQUIREMENTS OF 2104.3C3 WITH NO DIRECT COMPENSATION MADE THEREFORE.
8. DISPOSITION OF EXCESS EXCAVATED MATERIAL SHALL BE IN ACCORDANCE WITH THE REQUIREMENTS OF 2105.3D WITH NO DIRECT COMPENSATION THEREFORE.
9. WHERE MATCHING INTO THE INPLACE ROADWAY AT THE ENDS OF CONSTRUCTION, CUT VERTICALLY TO THE TOP OF THE GRADING GRADE, AND THEN AT A 20:1 TAPER TO THE BOTTOM OF THE RECOMMENDED SUBGRADE EXCAVATION.
10. WHERE CONNECTING NEW SURFACING TO AN INPLACE PAVEMENT, THE EXCAVATION SHALL BE BACKFILLED PROMPTLY TO AVOID UNDERMINING THE INPLACE PAVEMENT.
11. USE TACK COAT BETWEEN ALL BITUMINOUS MIXTURES PRIOR TO PLACING BITUMINOUS MIXTURES AND PRIOR TO PLACING ANY BITUMINOUS MIXTURES ON EXISTING CONCRETE OR BITUMINOUS SURFACES. THE BITUMINOUS TACK COAT MATERIAL SHALL BE APPLIED AT UNIFORM RATE OF 0.23 L/m2 BETWEEN BITUMINOUS LAYERS. THE APPLICATION RATES ARE FOR UNDILUTED EMULSION (AS SUPPLIED FROM THE REFINERY); ASPHALT EMULSION MAY BE FURTHER DILUTED IN THE FIELD IN ACCORDANCE WITH SPEC. 2357.
12. COMPACTION OF THE AGGREGATE BASE LAYERS SHALL BE BY THE "SPECIFIED DENSITY METHOD", UNLESS RECYCLED MATERIAL'S.
13. PLACE MINIMUM 100mm TOPSOIL OR SLOPE DRESSING ON ALL AREAS DISTURBED BY CONSTRUCTION AND SCHEDULED FOR PERMANENT TURF ESTABLISHMENT. FERTILIZE WITH COMMERCIAL FERTILIZER, ANALYSIS 10-10-10, AT A RATE OF 560 kg PER ha.
14. USE MIXTURE 90A SEED AND TYPE 1 MULCH IN AREAS TO BE SEEDED.
15. SOD ALL MAINTAINED LAWNS DISTURBED BY CONSTRUCTION.
16. ALL SOD UTILIZED WITHIN THE PROJECT LIMITS SHALL MEET THE REQUIREMENTS OF SPEC. 3878.2A (LAWN AND SOD).
17. ORGANIC AND NONGRANULAR EXCAVATED MATERIAL MAY BE USED IN EMBANKMENT CONSTRUCTION IN AREAS OUTSIDE OF A 1 1/2:1 SLOPE FROM THE BACK OF CURB, OR GRADING P.I.
18. BITUMINOUS REMOVAL QUANTITY BASED ON SQUARE METER REMOVED. IN PLACE SURFACE ASSUMED TO BE 244 mm IN DEPTH. CONTRACTOR SHALL INVESTIGATE AND MAKE OWN DETERMINATION OF ACTUAL PAVEMENT DEPTH.
19. ALL SILT FENCING AS SHOWN IN THE PLANS SHALL BE IN PLACE PRIOR TO THE COMMENCEMENT OF GRADING OPERATIONS.
20. A DOUBLE ROW OF BALE CHECKS SHALL BE INSTALLED ALONG DITCH RUNS FOR EROSION CONTROL AS DIRECTED BY THE ENGINEER.
21. TOPSOIL STRIPPINGS TO BE SALVAGED AND UTILIZED TO ITS FULLEST EXTENT WITHIN THE PROJECT LIMITS.

BASE AND BITUMINOUS QUANTITIES CHART

Table with columns: STATION - STATION, LOCATION, DESCRIPTION, BIT. SURFACE CONSTRUCTION, BITUMINOUS (40 mm WEAR, 60 mm BINDER, 120 mm BASE), TACK COAT, AGGREGATE (BASE CL-5A), and m3. Includes sub-sections for LNB ALIGNMENT, LSB ALIGNMENT, and CITY ROADS.

TACK COAT INCLUDES TWO LAYERS. (0.23 L/m2)
6 mm BITUMINOUS THICKNESS ADDED TO BINDER AND BASE COURSES.

TABULATION CHARTS

EARTHWORK SUMMARY, CONSTRUCTION NOTES
BASE AND BITUMINOUS QUANTITIES CHART

Table with columns: NO, DATE, BY, CKD, APPR, REVISION, NAME: 10-EarthW.dwg, 3-1-99, 10:10:05 am EST

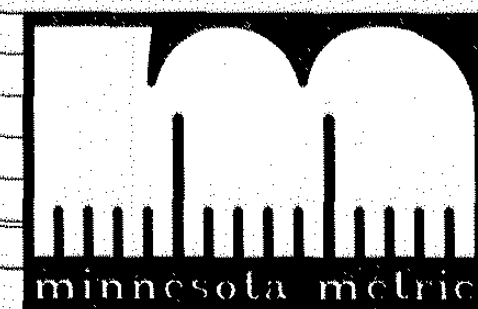

I HEREBY CERTIFY THAT THIS PLAN WAS PREPARED BY ME OR UNDER MY DIRECT SUPERVISION AND THAT I AM A DULY REGISTERED PROFESSIONAL ENGINEER UNDER THE LAWS OF THE STATE OF MINNESOTA.

DRAWN BY: MN DATE 12/22/98
DESIGN BY: KGJ DATE 12/22/98
CHECKED BY: LR DATE 12/22/98

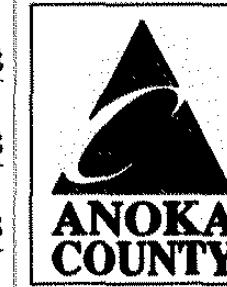

ANOKA COUNTY
HIGHWAY DEPT.

STATE PROJECT NO. 02-601-37
STATE PROJECT NO. 127-020-20
STATE PROJECT NO. 114-020-18
COUNTY PROJECT NO.

TABULATION CHARTS

Sheet 10 of 93 Sheets

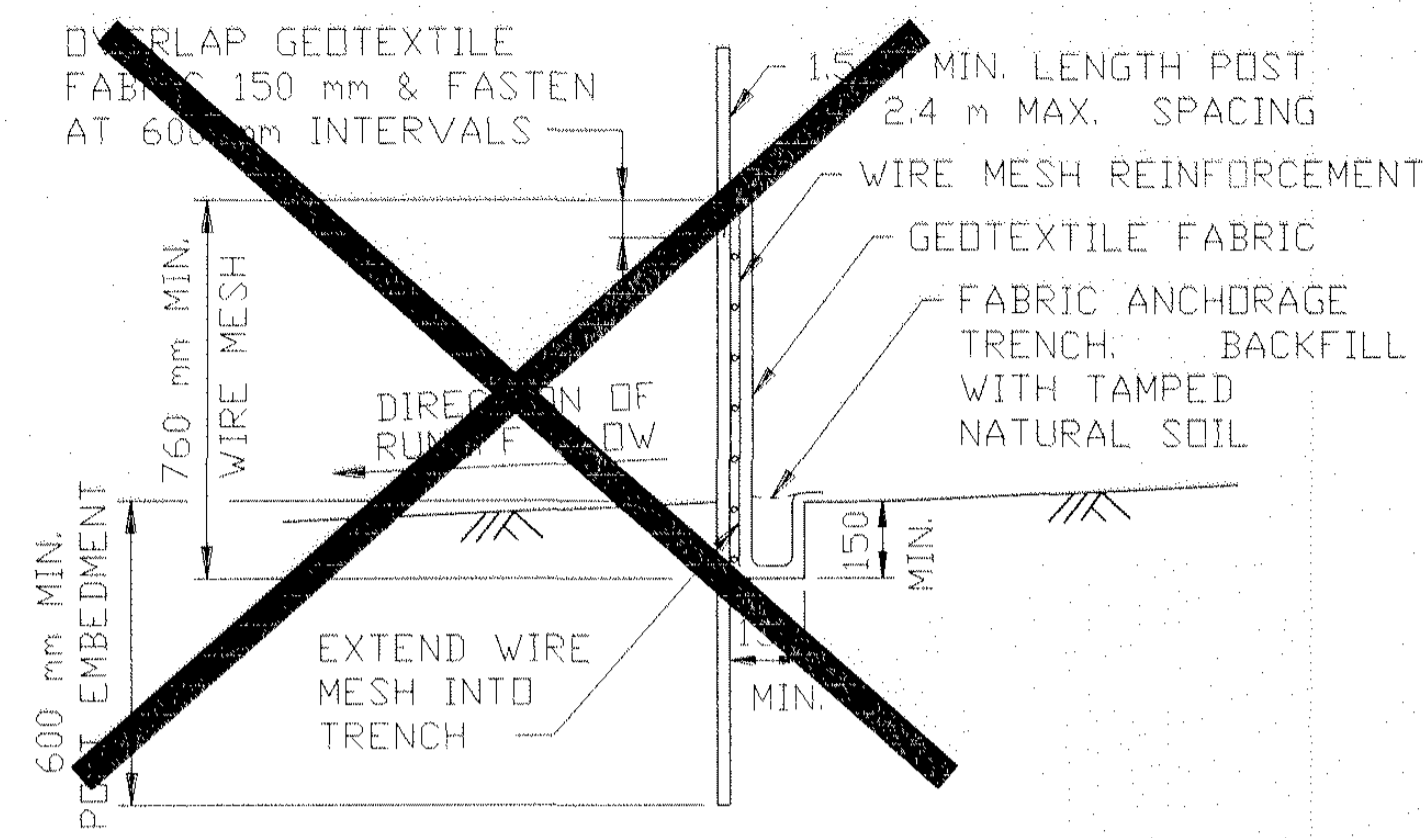

HEAVY DUTY

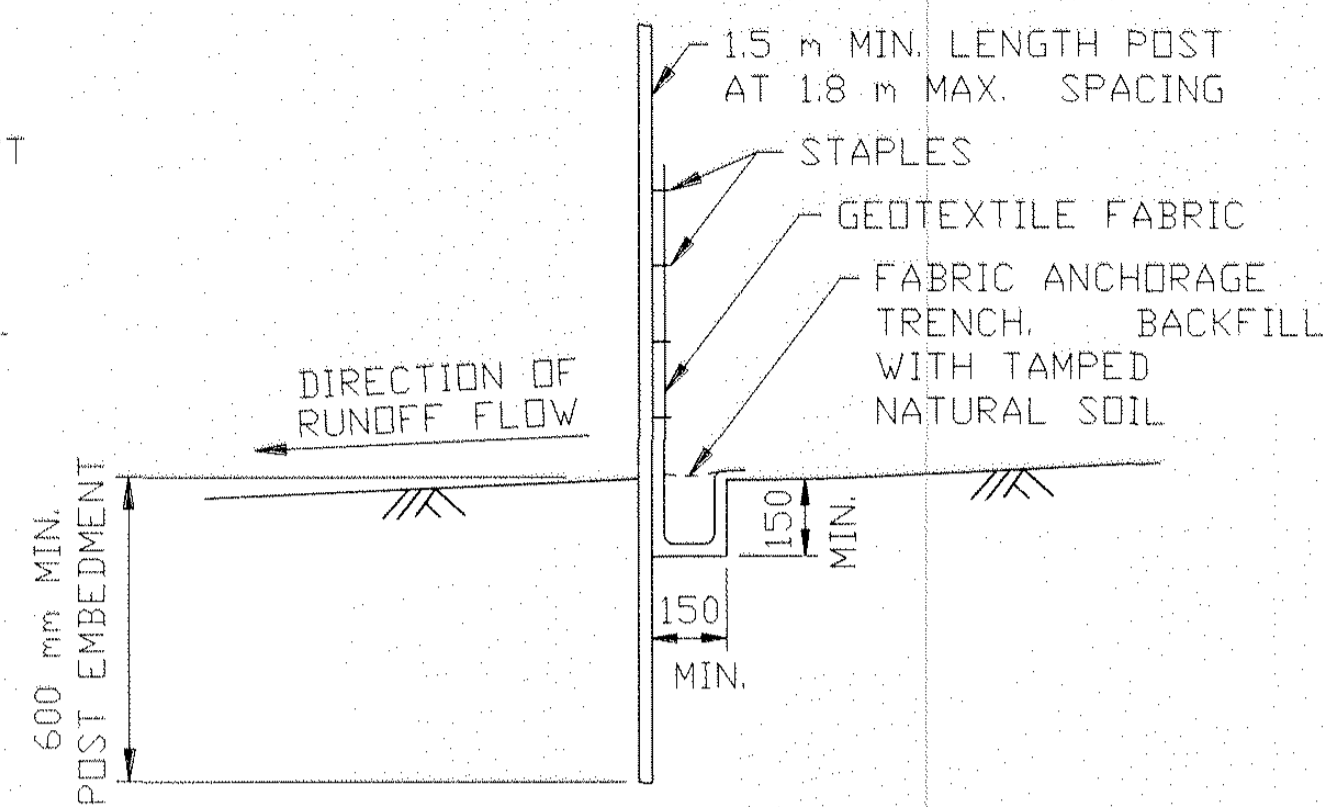

SELF SUPPORTING TYPE PREASSEMBLED

SILT FENCE DETAILS
TO PROTECT AREAS FROM SHEET FLOW
(SEE SPEC. 3886)

DESIGN CRITERIA:
MAXIMUM CONTRIBUTING AREA: 1.2 ha

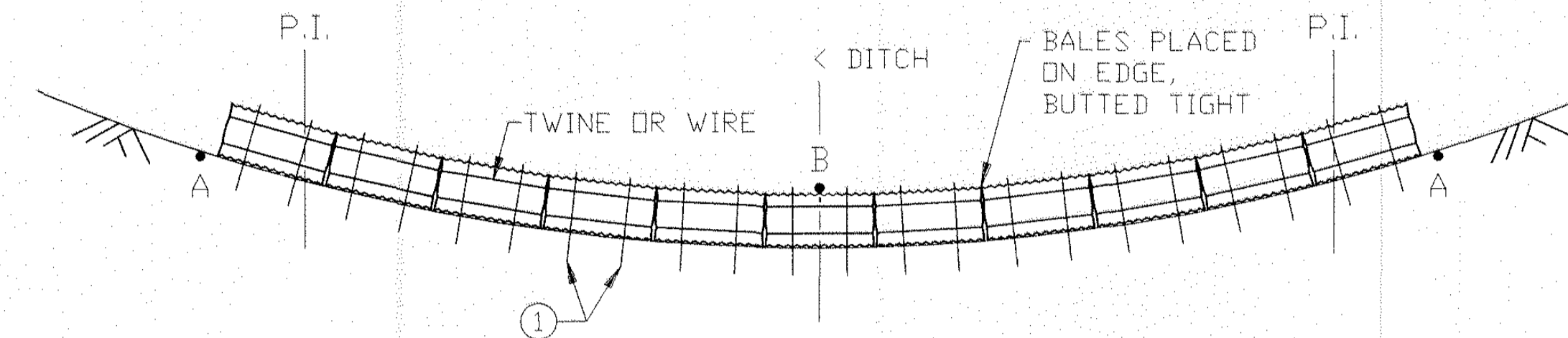

NOTE:
POINT A MUST BE HIGHER THAN POINT B
BALE DITCH SEDIMENT CHECK

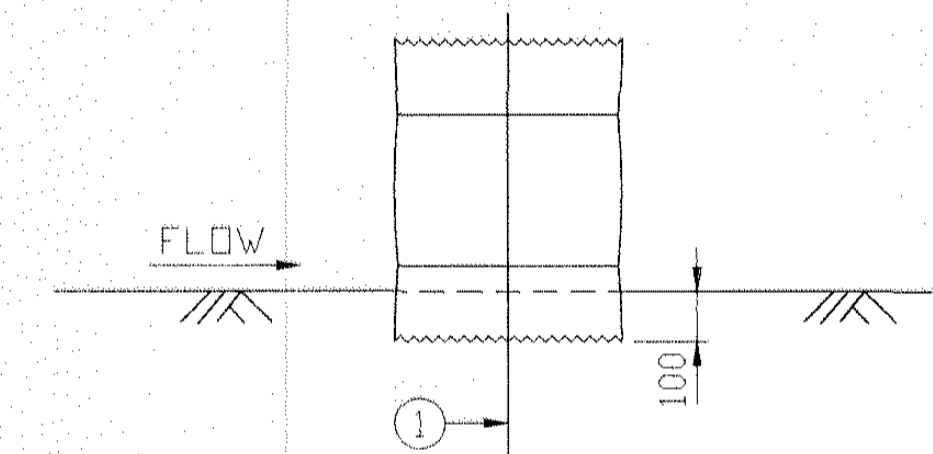

BALE CHECK DETAIL

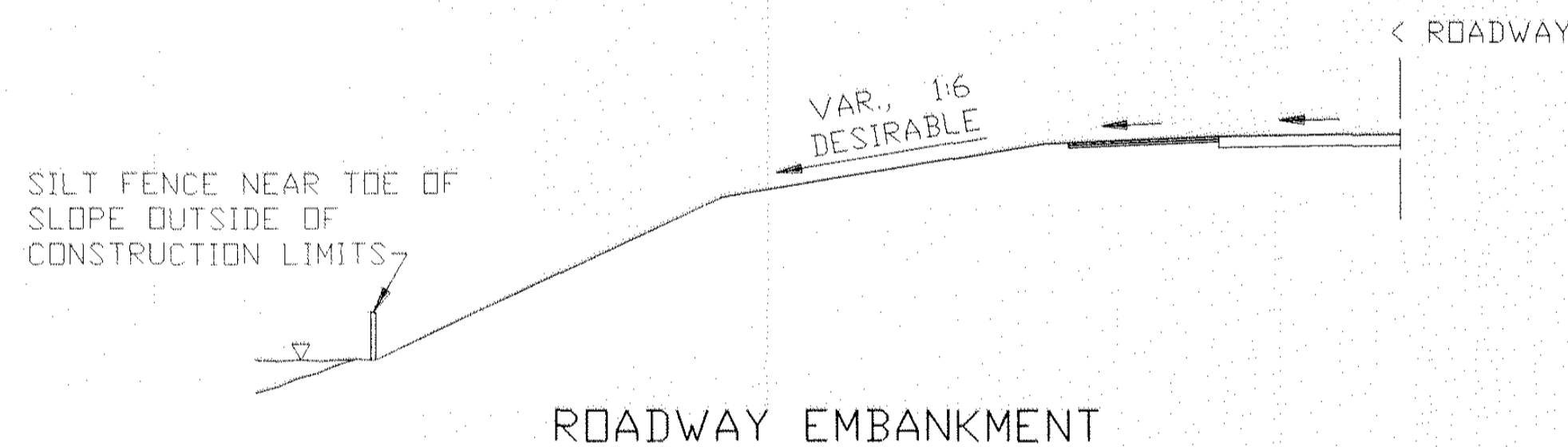

ROADWAY EMBANKMENT

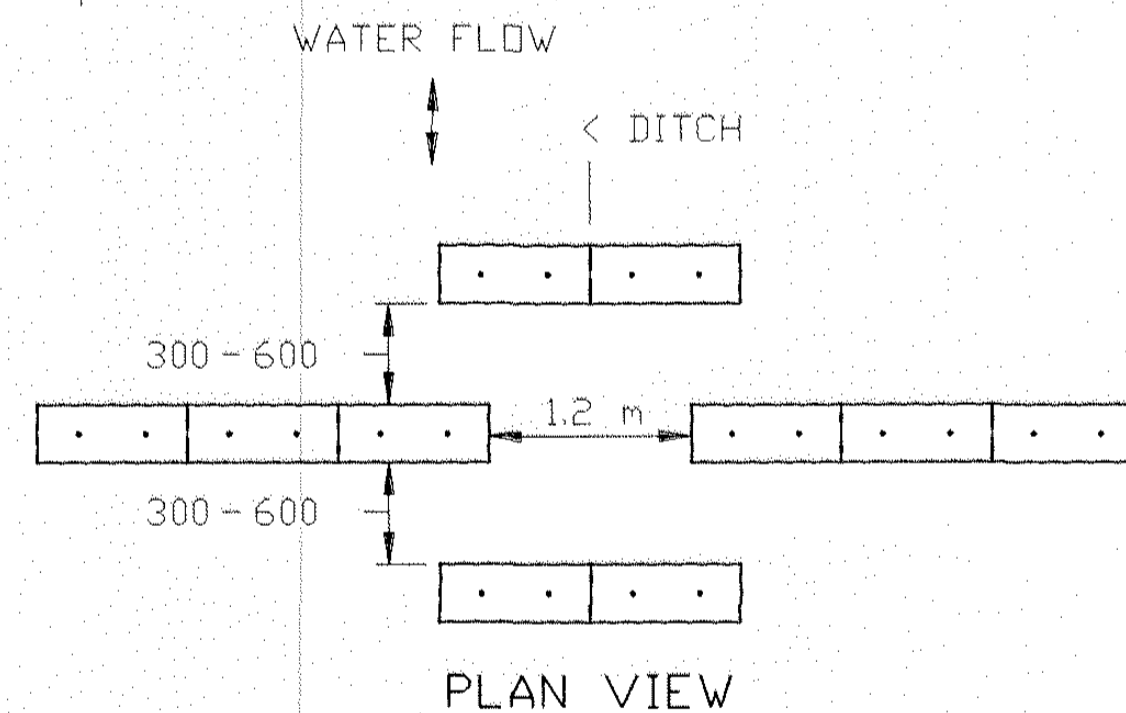

PLAN VIEW

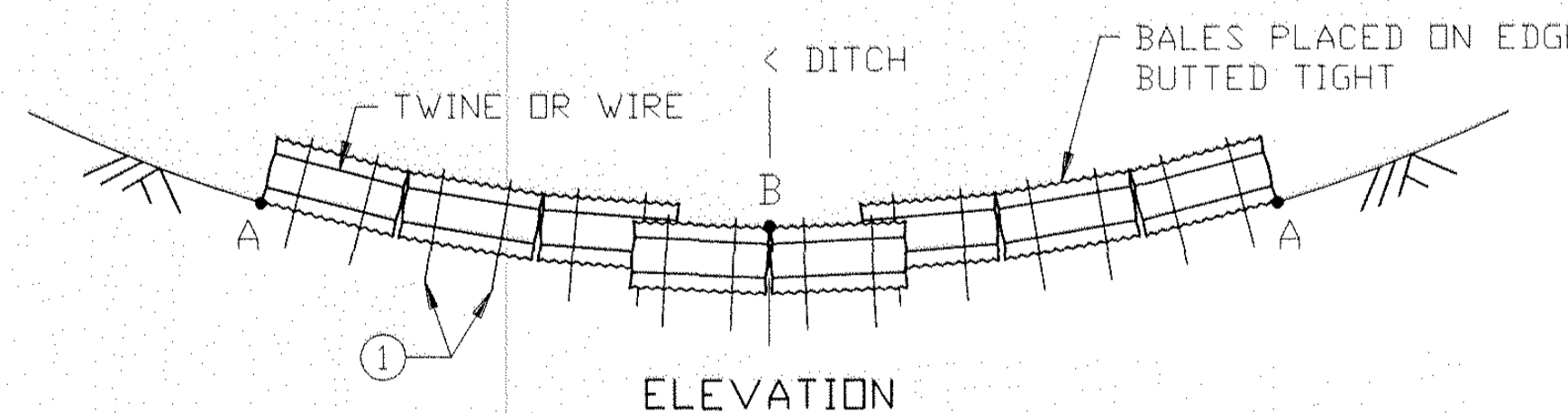

ELEVATION

NOTE:
POINT A MUST BE HIGHER THAN POINT B
BALE DITCH VELOCITY CHECKS
(WILL REQUIRE A MINIMUM OF 10 BALES PER SITE)

RECOMMENDED SPACING BETWEEN DITCH CHECKS	
DITCH GRADE (%)	SPACING (m)
2	30
4	23
6	15
8	12
10	8

DESIGN CRITERIA:

	BALE	ROCK
STORM FREQUENCY:	2 YR. - 24 HR.	10 YR. - 24 HR.
MAX. FLOW VELOCITY:	1.5 m/s	3.6 m/s
MAX. DITCH GRADE:	5%	—
MAX. DRAINAGE AREA:	0.8 ha	2.0 ha

NOTE:
TWO 50 mm X 50 mm WOOD STAKES OR REINFORCING BARS IN EACH BALE AND EMBEDDED IN THE GROUND 250 mm MINIMUM.

NOTE: ALL DIMENSIONS ARE IN MILLIMETERS, EXCEPT AS NOTED.

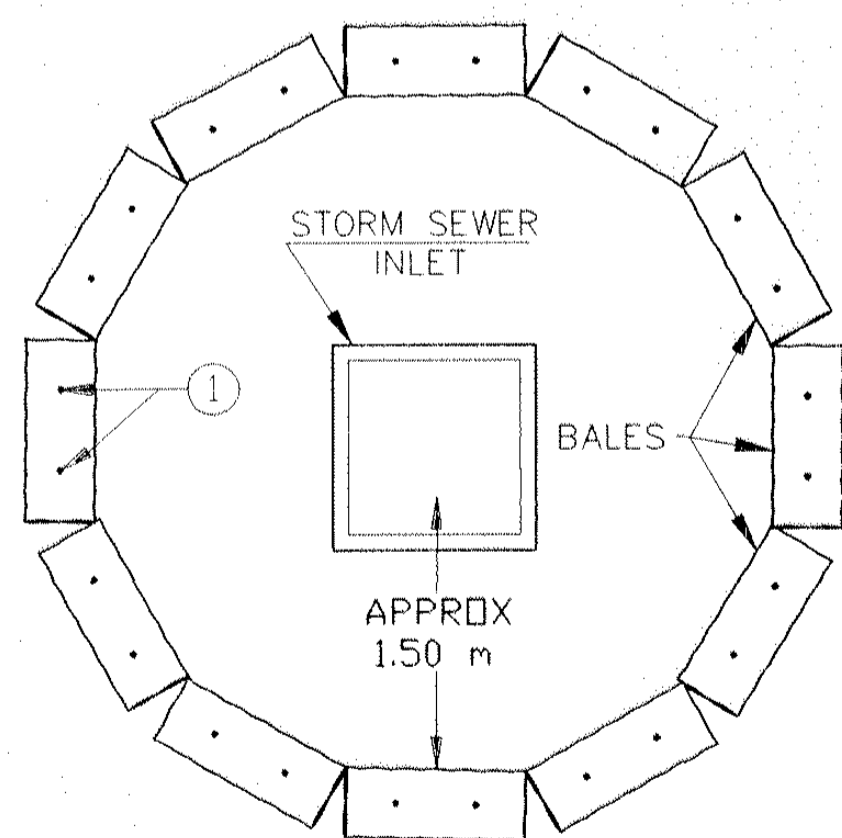

BALE CHECK TO PROTECT STORM SEWER INLETS

NO	DATE	BY	CKD	APPR	REVISION

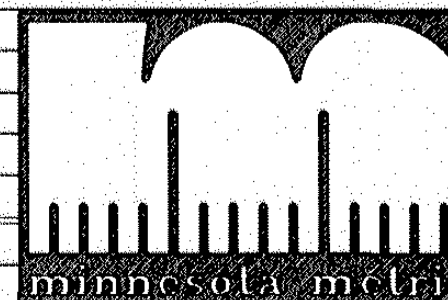

I HEREBY CERTIFY THAT THIS PLAN WAS PREPARED BY ME OR UNDER MY DIRECT SUPERVISION AND THAT I AM A DULY REGISTERED PROFESSIONAL ENGINEER UNDER THE LAWS OF THE STATE OF MINNESOTA.
DATE _____ REG. NO. _____

DRAWN BY _____ DATE _____
DESIGN BY _____ DATE _____
CHECKED BY _____ DATE _____

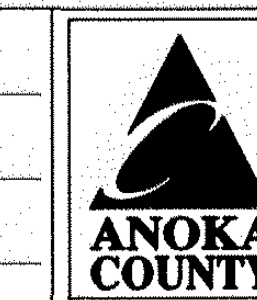

ANOKA COUNTY HIGHWAY DEPT.

STATE PROJECT NO. 02-601-37
STATE PROJECT NO. 127-020-20
STATE PROJECT NO. 114-020-18
COUNTY PROJECT NO. _____

TEMPORARY EROSION CONTROL
Sheet 11 of 93 Sheets

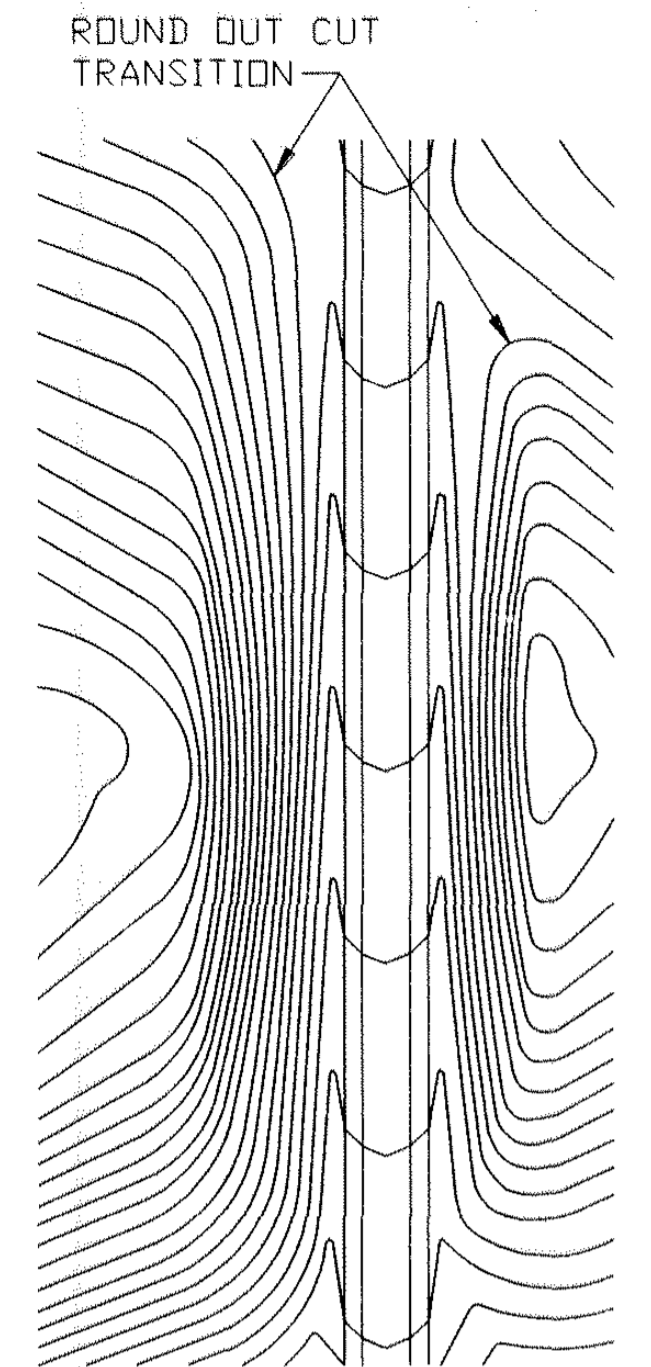

CONTOURING ROAD CUTS

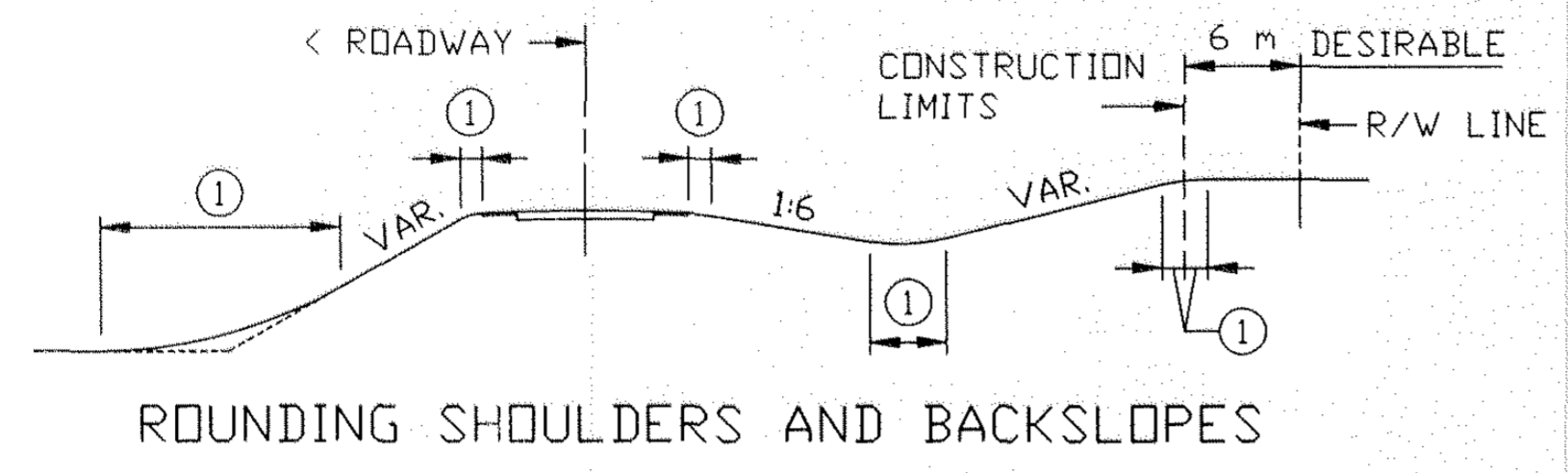

ROUNDING SHOULDERS AND BACKSLOPES

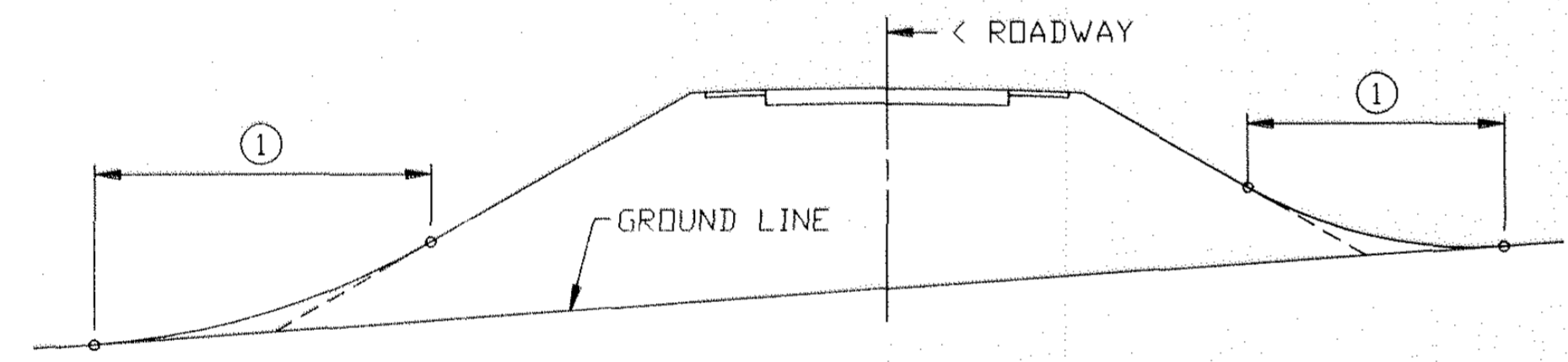

SHAPING FOR DRAINAGE ALONG THE TOE OF FILL SLOPES

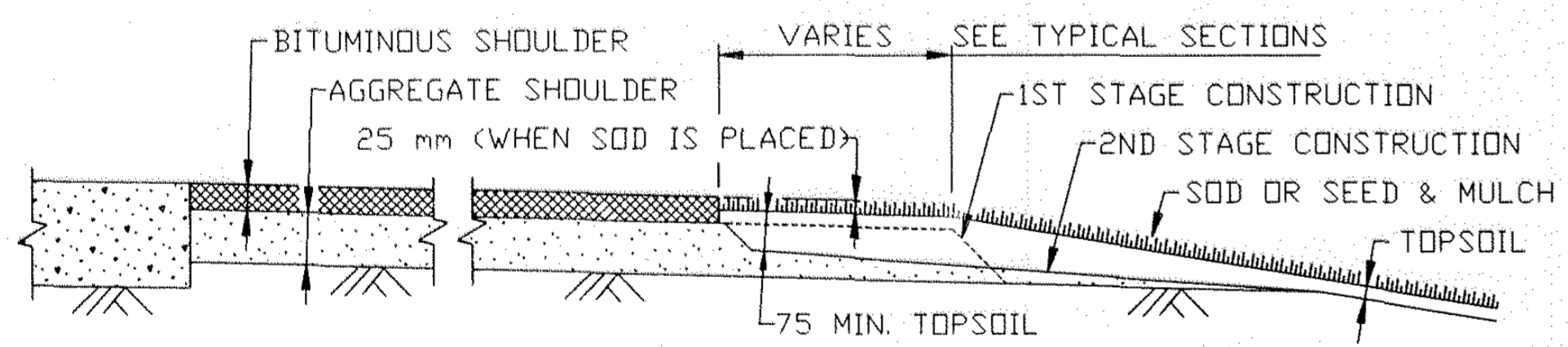

SHAPING AND TOPSOILING INSLOPES

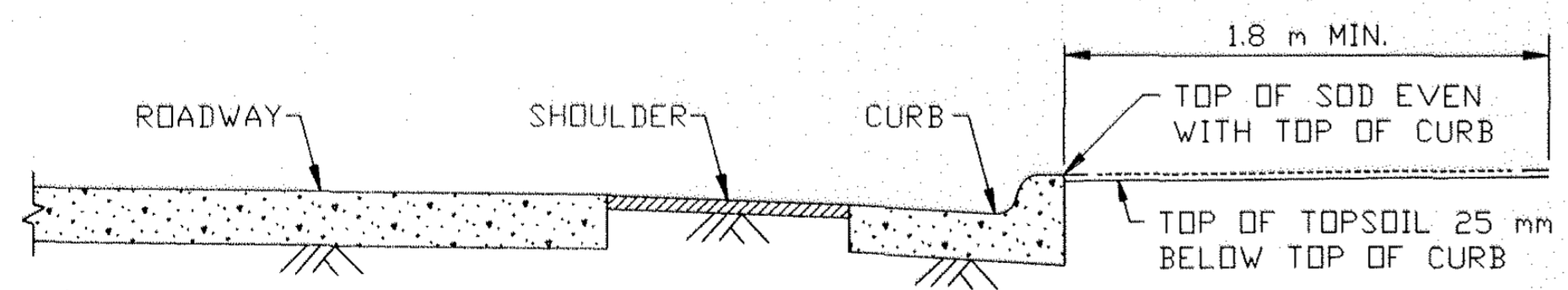

SHAPING ADJACENT TO CURBS WHEN SOD IS PLACED

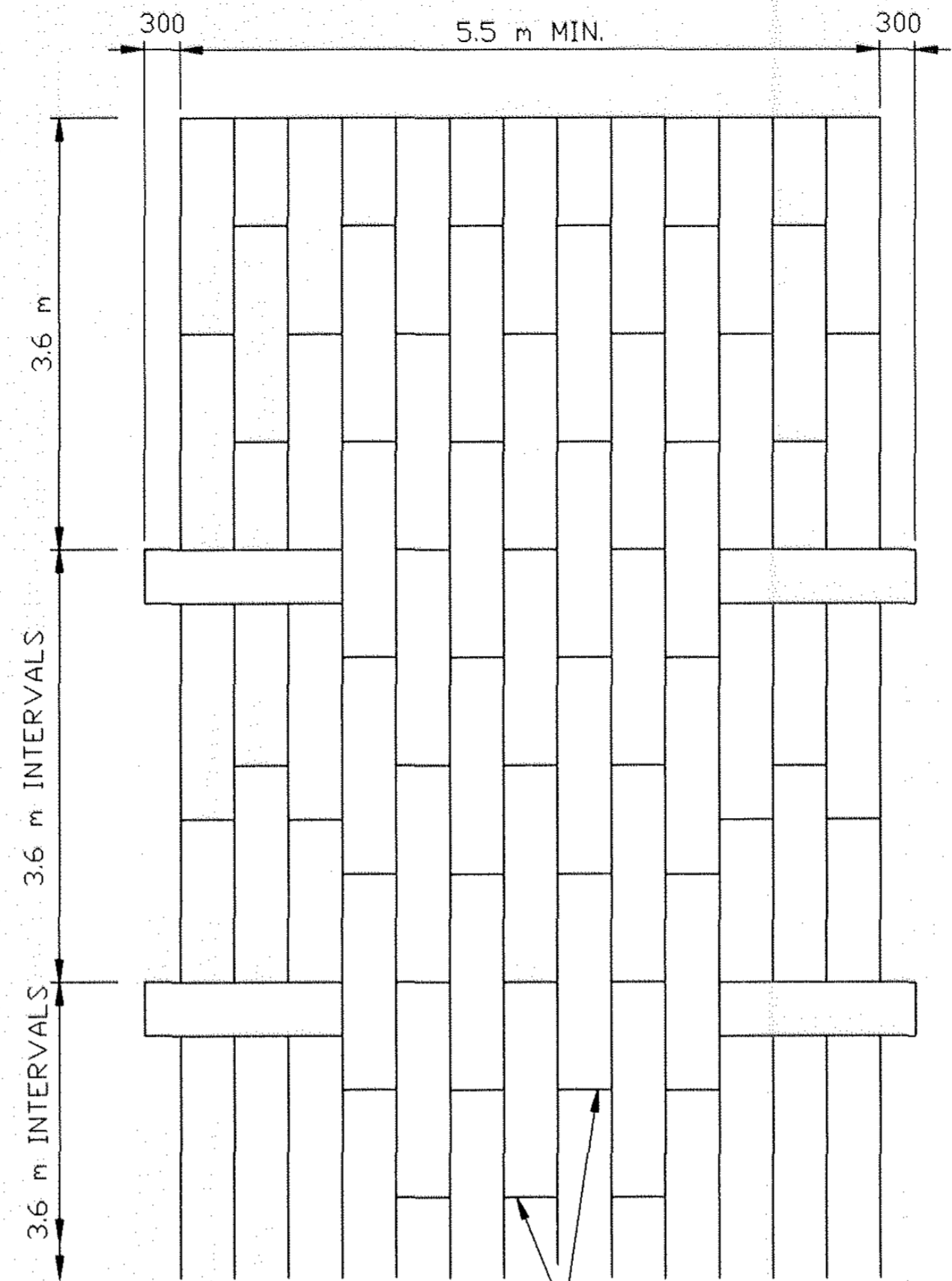

STAGGER JOINTS
PLAN VIEW

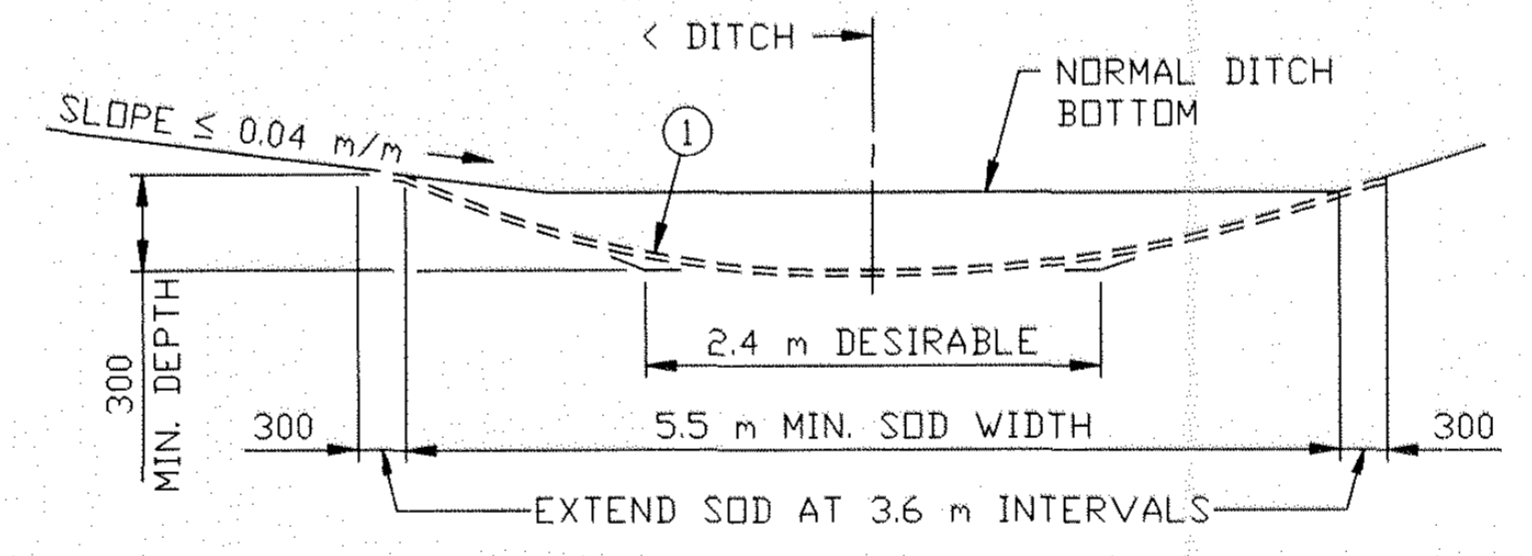

SODDED DITCH CROSS SECTION
WHERE FRONT OR BACK SLOPE IS FLAT (LESS THAN 0.04 m/m), FIRST NOTCH DITCH AND THEN PROVIDE ROUNDING.

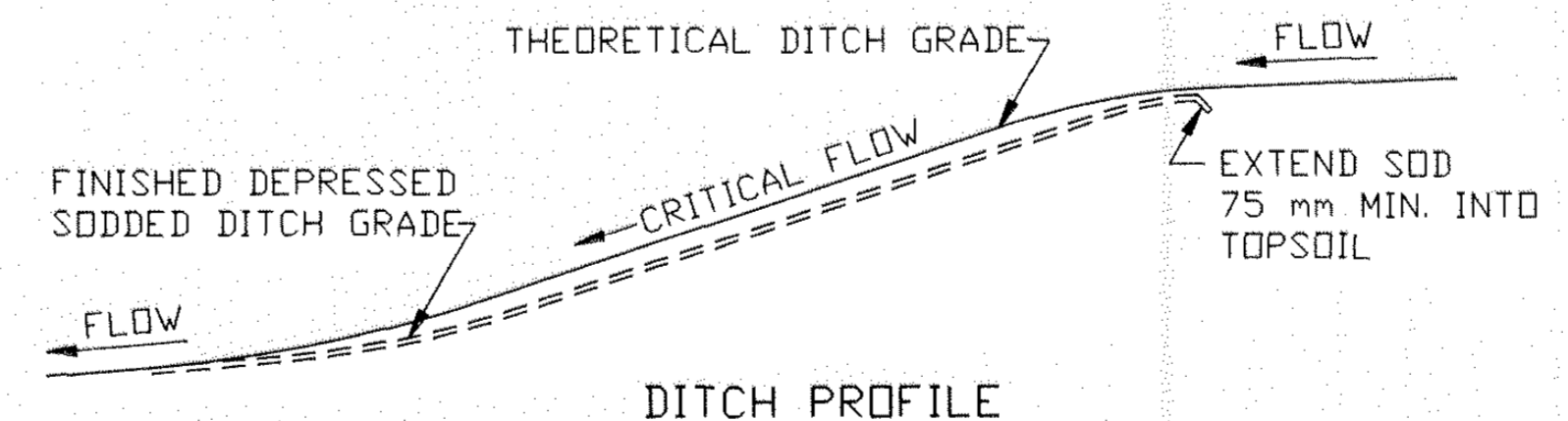

DITCH PROFILE
SODDED DITCH DETAILS

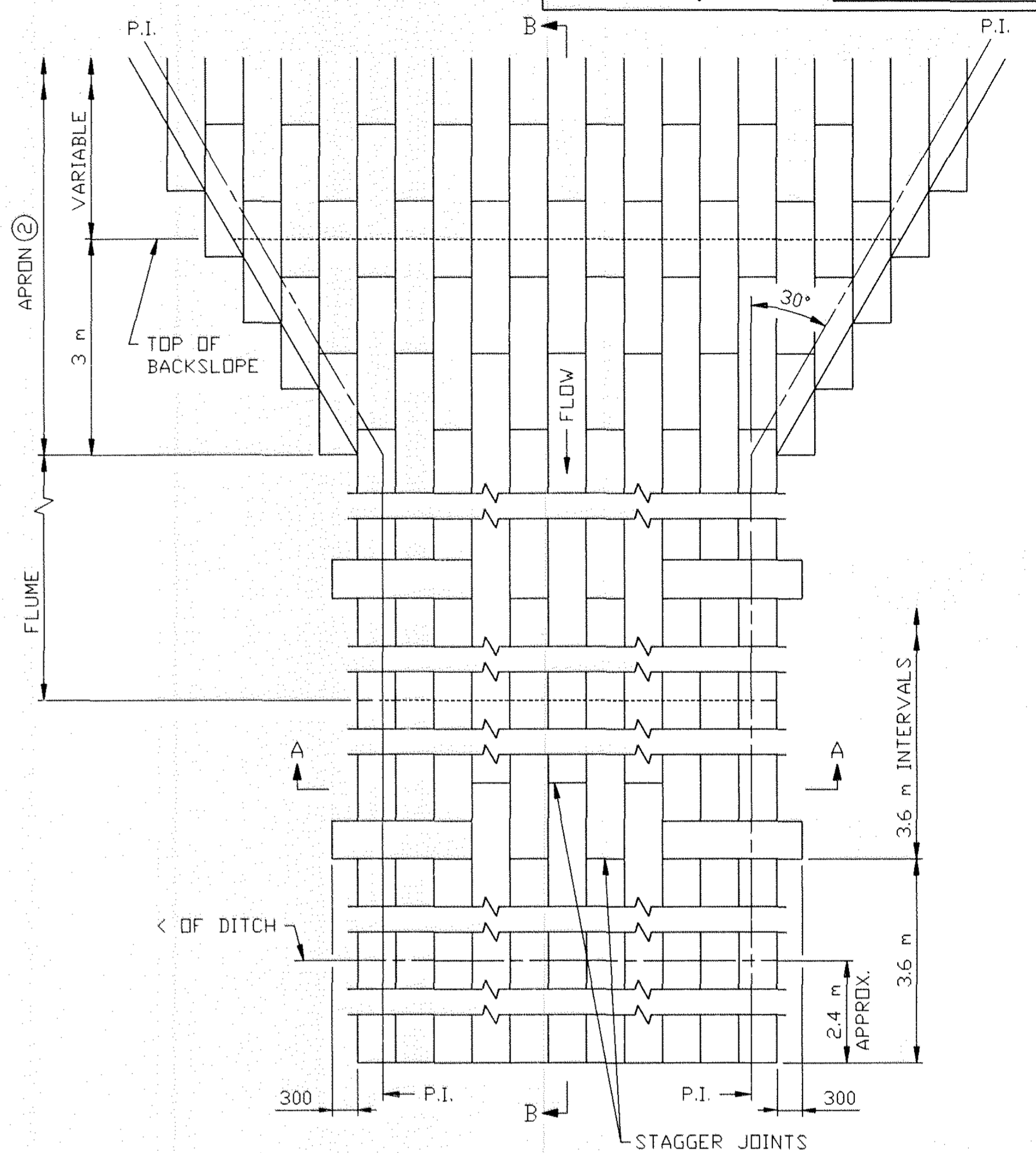

PLAN VIEW

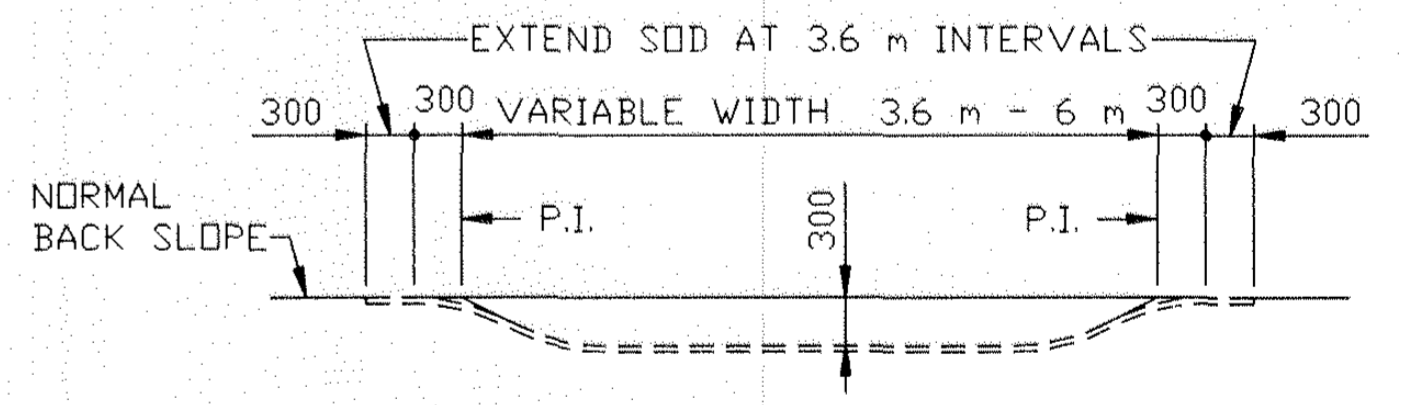

SECTION A-A

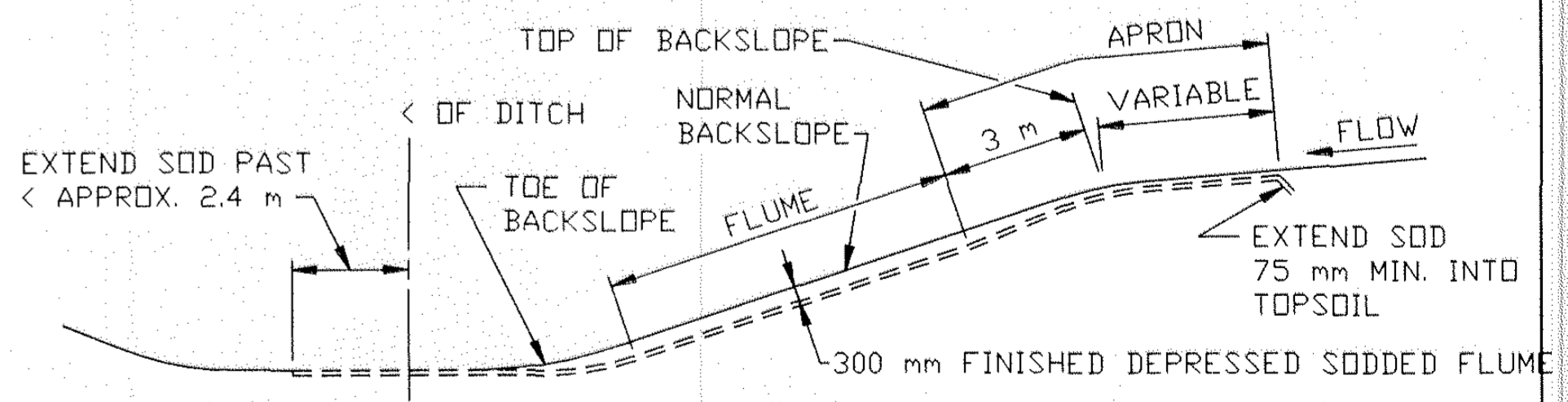

SECTION B-B

SODDED FLUME DETAILS

- NOTES:
SEE SPEC. 2575.3 FOR ADDITIONAL INFORMATION.
① FOR ROUNDING, SEE ROAD DESIGN MANUAL.
② CONSTRUCT TAPER AS DIRECTED BY THE ENGINEER.

NOTE: ALL DIMENSIONS ARE IN MILLIMETERS, EXCEPT AS NOTED.

STANDARD SHEET No. 5-297.404

NO	DATE	BY	CKD	APPR	REVISION

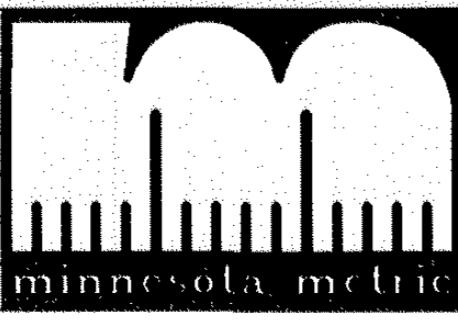

I HEREBY CERTIFY THAT THIS PLAN WAS PREPARED BY ME OR UNDER MY DIRECT SUPERVISION AND THAT I AM A DULY REGISTERED PROFESSIONAL ENGINEER UNDER THE LAWS OF THE STATE OF MINNESOTA.
DATE _____ REG. NO. _____

DRAWN BY _____ DATE _____
DESIGN BY _____ DATE _____
CHECKED BY _____ DATE _____

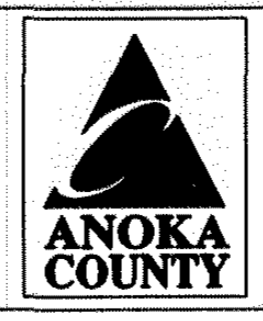

ANOKA COUNTY
HIGHWAY DEPT.

STATE PROJECT NO. 02-601-37
STATE PROJECT NO. 127-020-20
STATE PROJECT NO. 114-020-18
COUNTY PROJECT NO. _____

PERMANENT EROSION CONTROL
ALONG ROADWAYS, DITCHES AND FLUME
Sheet 12 of 93 Sheets

TYPICAL MAINLINE CONSTRUCTION

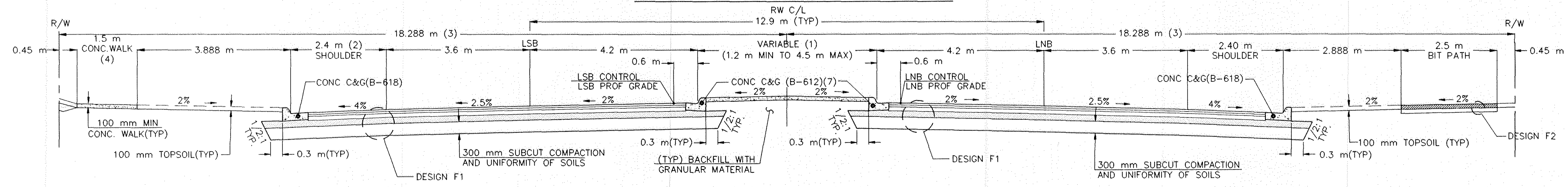

TYPICAL TURN BAY CONSTRUCTION

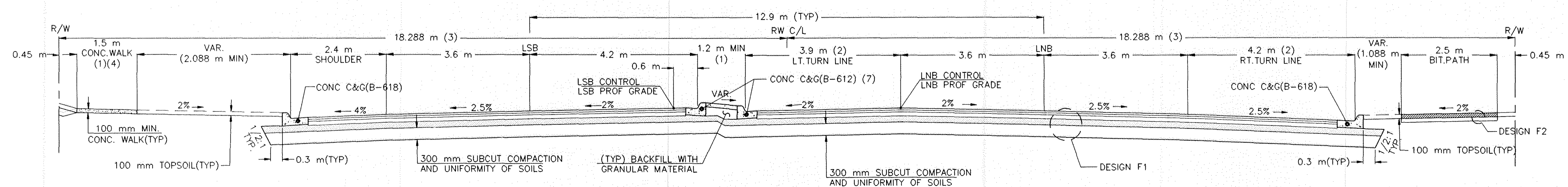

SPECIAL SIDEWALK AND BIT. PATH CONSTRUCTION

LNB STA. 11+120.000 TO STA. 11+265.000 RT.
 LSB STA. 10+895.000 TO STA. 10+910.000 LT.
 LSB STA. 11+210.000 TO STA. 11+270.000 LT.

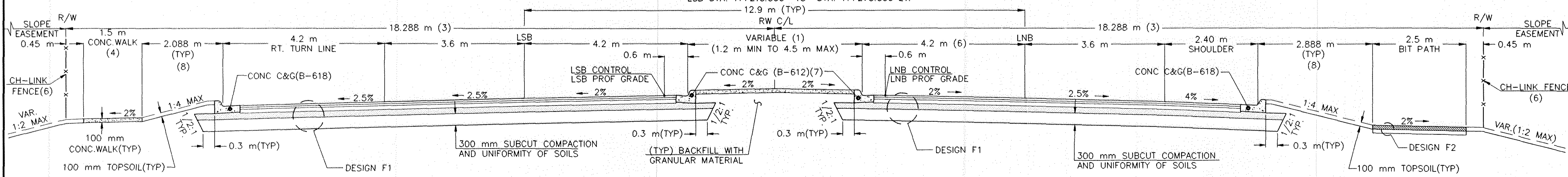

DETAIL "A"

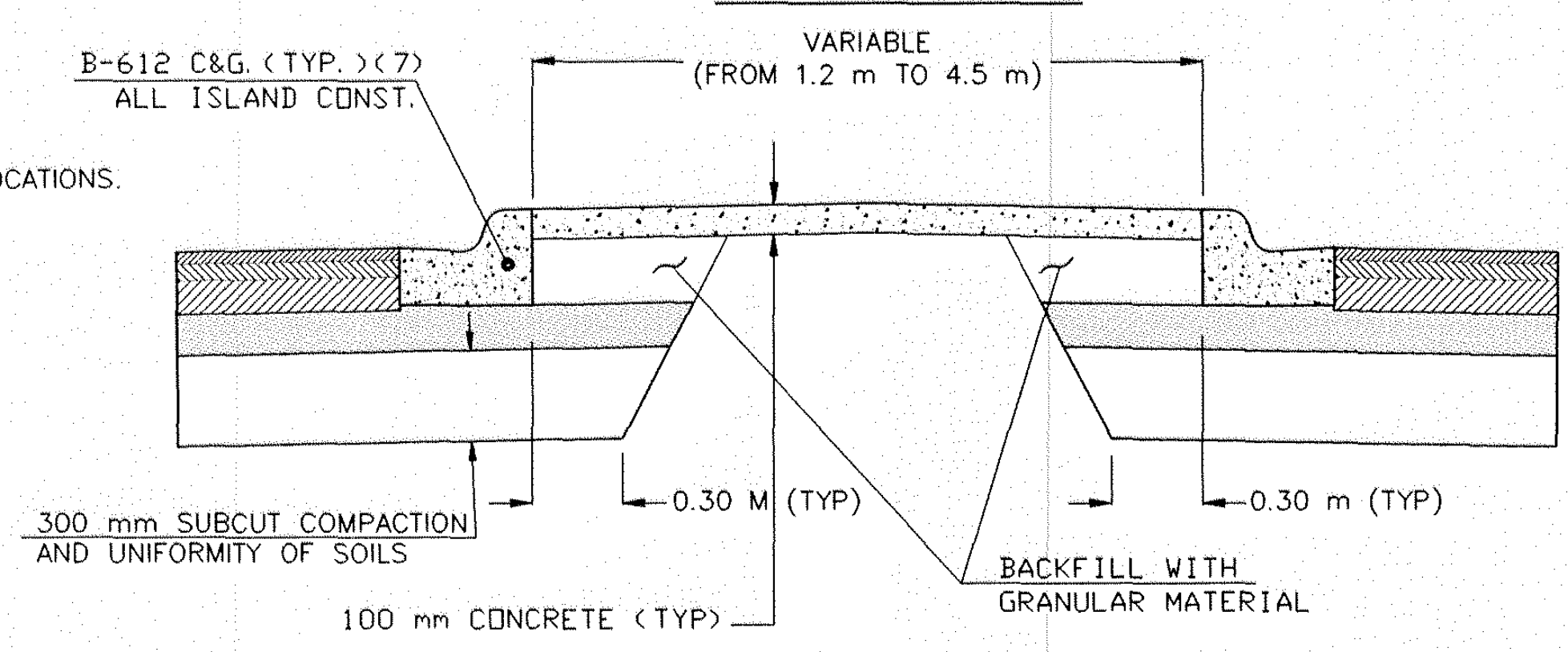

DESIGN F-2
BITUMINOUS PATH

50 mm TYPE HWVE47540C
 100 mm AGGREGATE BASE CLASS 5

DESIGN F-1

40 mm TYPE HWVE47540C
 60 mm TYPE HVNW37540C
 120 mm TYPE MVNW35035B
 180 mm AGGREGATE BASE CLASS 5

- (1) SEE PLAN AND PROFILE SHEET FOR LOCATION.
- (2) SEE CHART--- FOR RT TURN LANE LOCATION.
- (3) SEE PLAN AND PROFILE SHEET FOR VAR. R/W WIDTHS LOCATIONS.
- (4) BEGIN STA. 10+887.500 TO STA 11+927.100
- (5) SEE PLAN PROF SHEET FOR LT. TURN LANE LOC.
- (6) F&I CHAIN LINK FENCE AT R/W LINE IN 1:2 SLOPE AREAS. SEE CHART S FOR LOCATION.
- (7) B-12 C&G IN MEDIAN AND FREE RIGHT ISLAND CONST.
- (8) 1.5m LNB 11+120 - 11+253 RT.
 1.5m LSB 11+210 - 11+260 LT.
 SEE PLAN VIEW FOR TRANSITIONS.

NO	DATE	BY	CKD	APPR	REVISION
NAME:	13-Typcl.dwg		82698	42120	

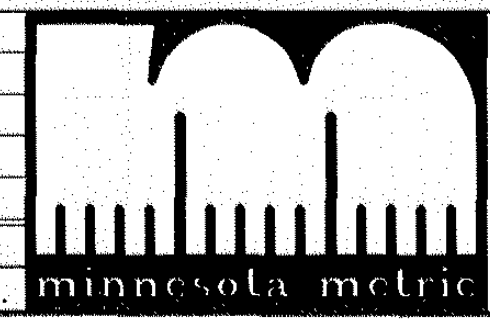

I HEREBY CERTIFY THAT THIS PLAN WAS PREPARED BY ME OR UNDER MY DIRECT SUPERVISION AND THAT I AM A DULY REGISTERED PROFESSIONAL ENGINEER UNDER THE LAWS OF THE STATE OF MINNESOTA.

DATE _____ REG. NO. _____

DRAWN BY _____ DATE _____
 DESIGN BY _____ DATE _____
 CHECKED BY _____ DATE _____

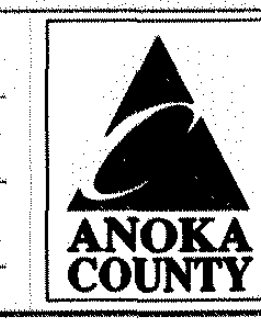

ANOKA COUNTY
HIGHWAY DEPT.

STATE PROJECT NO. 02-601-37
 STATE PROJECT NO. 127-020-20
 STATE PROJECT NO. 114-020-18
 COUNTY PROJECT NO. _____

TYPICAL SECTIONS
 Sheet 13 of 93 Sheets

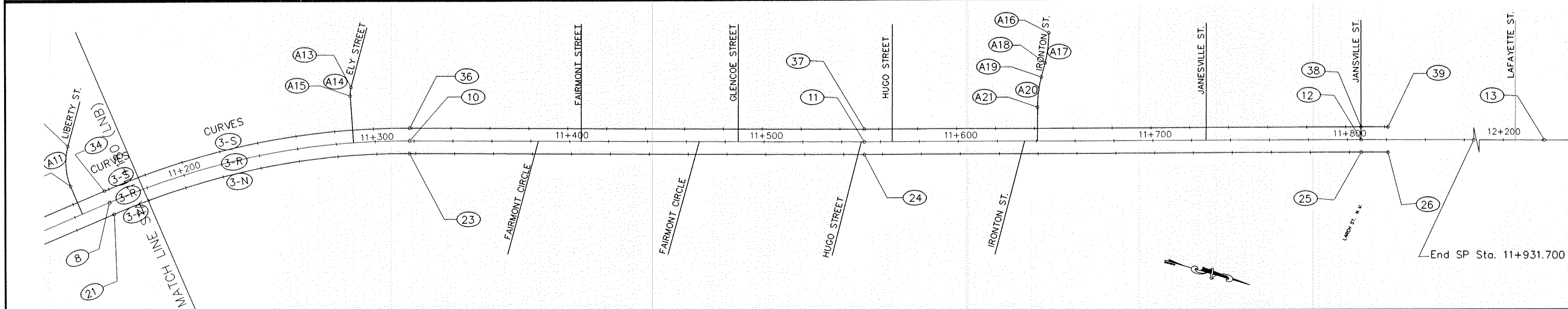
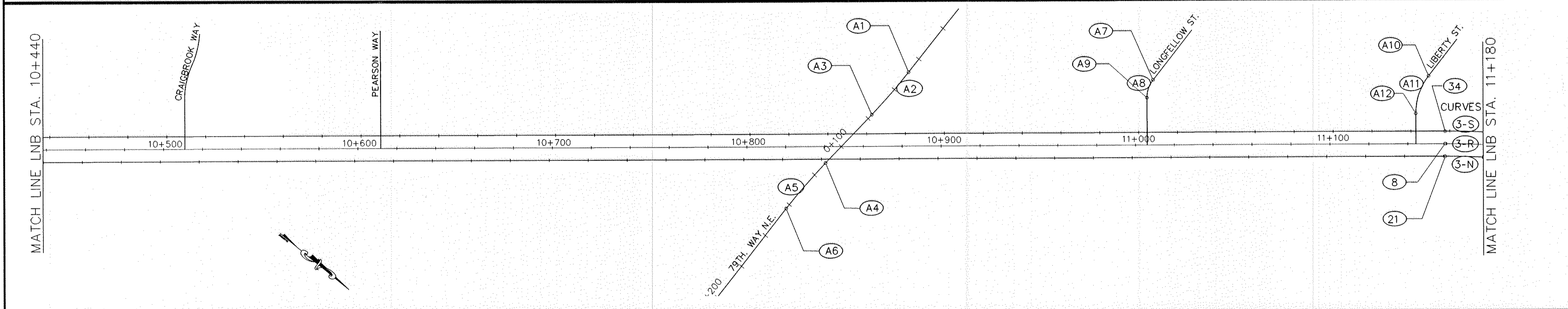
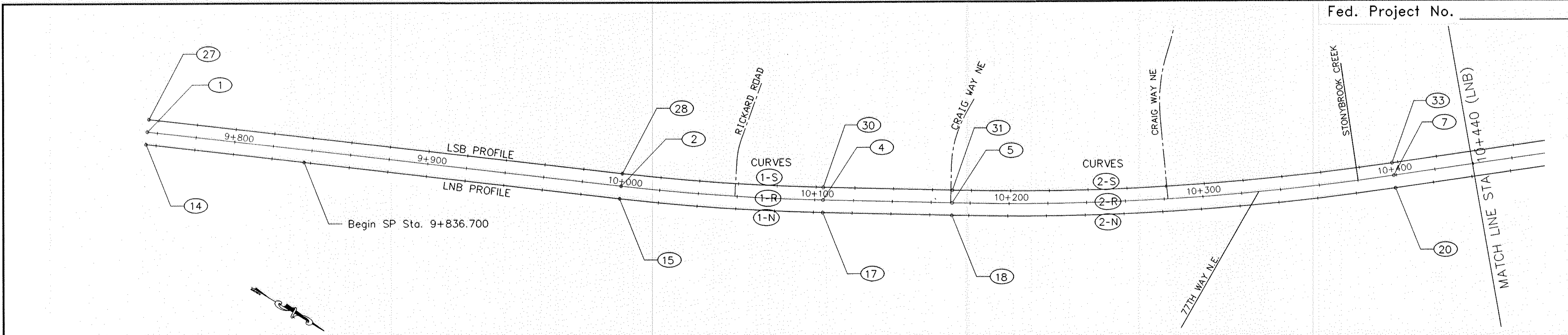

NO	DATE	BY	CKD	APPR	REVISION

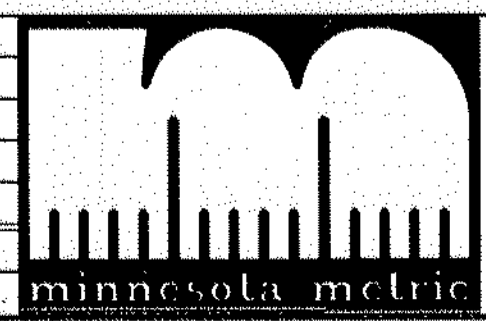

I HEREBY CERTIFY THAT THIS PLAN WAS PREPARED BY ME OR UNDER MY DIRECT SUPERVISION AND THAT I AM A DULY REGISTERED PROFESSIONAL ENGINEER UNDER THE LAWS OF THE STATE OF MINNESOTA.

DATE _____ REG. NO. _____

DRAWN BY _____ DATE _____
 DESIGN BY _____ DATE _____
 CHECKED BY _____ DATE _____

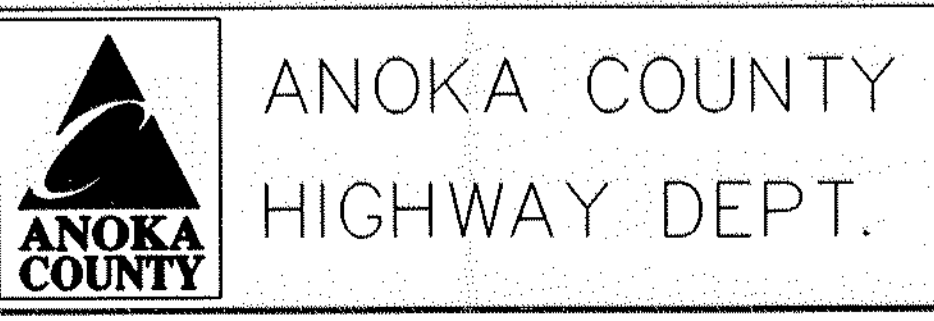

STATE PROJECT NO. 02-601-37
 STATE PROJECT NO. 127-020-20
 STATE PROJECT NO. 114-020-18
 COUNTY PROJECT NO. _____

ALIGNMENT PLAN
 Sheet 14 of 93 Sheets

ALIGNMENT TABULATION												
CURVE NO.	POINT NO.	POINT TYPE	LOCATION	CURVE DATA					COORDINATES			
				COURSE	DELTA	RADIUS(m)	TANGENT(m)	LENGTH(m)	NORTHING	EASTING	AZIMUTH	
R/W CENTERLINE ALIGNMENT												
	1	PI	LRW STA. 9+754.82	N24°28'01"W					20612.8633	270726.8336	335°31'59"	
	2	PC	LRW STA. 10+000.00						20836.0257	270625.2876		
1-R	3	PI	LRW STA. 10+052.16	N29°35'52"W	05°07'51"	1164.25	52.16	104.26	20883.5046	270603.6832	150°24'09"	
	4	PT	LRW STA. 10+104.26						20928.8612	270577.9194		
	5	PC	LRW STA. 10+170.76						20986.6841	270545.0744		
2-R	6	PI	LRW STA. 10+285.00	N39°16'18"W	09°40'26"	1350.00	114.24	227.94	20353.8287	269565.5876	320°43'42"	
	7	PT	LRW STA. 10+398.70						21174.4577	270416.3356		
	8	PC	LRW STA. 11+159.17						21763.1771	269934.9584		
3-R	9	PI	LRW STA. 11+239.60	N15°57'52"W	23°18'27"	390.00	80.44	158.65	21825.4471	269884.0421	164°02'08"	
	10	PT	LRW STA. 11+317.81						21902.7800	269861.9000		
	11	PI	LRW STA. 11+551.64	N16°19'55"W	00°22'03"				22127.5900	269797.6000	343°40'05"	
	12	PI	LRW STA. 11+807.03	N15°59'25"W	00°20'30"				22372.6800	269725.8000	344°00'35"	
	13	PI	LRW STA. 12+221.16						22770.7800	269611.7000		
LNB ALIGNMENT												
	14	PI	LNB STA. 9+754.82	N24°28'01"W					20615.5346	270732.7040	335°31'59"	
	15	PC	LNB STA. 10+000.00						20838.6948	270631.1591		
1-N	16	PI	LNB STA. 10+052.45	S29°35'51"E	05°07'51"	1170.70	52.46	104.84	20886.4377	270609.4347	150°24'09"	
	17	PT	LNB STA. 10+104.83						20932.0465	270583.5276		
	18	PC	LNB STA. 10+171.33						20989.8698	270550.6827		
2-N	19	PI	LNB STA. 10+286.12	N39°16'18"W	09°40'26"	1356.45	114.79	229.03	21089.6783	270493.9887	320°43'42"	
	20	PT	LNB STA. 10+400.36						21178.5405	270421.3289		
	21	PC	LNB STA. 11+160.83						21767.2600	269940.0000		
3-N	22	PI	LNB STA. 11+239.94	S15°57'52"E	23°18'27"	383.55	79.11	156.02	21828.5000	269889.9000	164°02'08"	
	23	PT	LNB STA. 11+316.86						21904.5600	269868.1000		
	24	PI	LNB STA. 11+550.71	N16°19'55"W	00°22'03"				22129.3900	269803.8000	343°40'05"	
	25	PI	LNB STA. 11+806.10	N15°59'25"W	00°20'30"				22374.4700	269732.0000	344°00'35"	
	26	PI	LNB STA. 11+819.88						22387.7200	269728.2000		
LSB ALIGNMENT												
	27	PI	LSB STA. 9+754.82	N24°28'01"W					20615.5346	270732.7040	335°31'59"	
	28	PC	LSB STA. 10+000.00						20838.6948	270631.1591		
1-S	29	PI	LSB STA. 10+051.87	N29°35'52"W	05°07'51"	1157.80	51.87	103.68	20886.4377	270609.4347	150°24'09"	
	30	PT	LSB STA. 10+103.68						20932.0465	270583.5276		
	31	PC	LSB STA. 10+170.18						20989.8698	270550.6827		
2-S	32	PI	LSB STA. 10+283.87	N39°16'18"W	09°40'26"	1343.55	113.69	226.85	21089.6783	270493.9887	320°43'42"	
	33	PT	LSB STA. 10+397.03						21178.5405	270421.3289		
	34	PC	LSB STA. 11+160.83						21767.2600	269940.0000		
3-S	35	PI	LSB STA. 11+239.26	N15°57'52"W	23°18'27"	396.45	81.77	161.27	21828.5000	269889.9000	164°02'08"	
	36	PT	LSB STA. 11+318.77						21904.5600	269868.1000		
	37	PI	LSB STA. 11+552.58	N16°19'55"W	00°22'03"				22129.3900	269803.8000	343°40'05"	
	38	PI	LSB STA. 11+807.97	N15°59'25"W	00°20'30"				22374.4700	269732.0000	344°00'35"	
	39	PI	LSB STA. 11+821.80						22387.7200	269728.2000		
CITY STREETS												
	A1	PC	STA. 0+048.52	79TH. WAY N.E.	N89°25'32"E				21525.8123	270080.1650	270°34'28"	
A2	A2	PI	STA. 0+062.92	79TH. WAY N.E.		05°29'40"	300.00	14.40	28.77			
	A3	PT	STA. 0+077.29	79TH. WAY N.E.	N85°04'48"W				21524.7220	270108.9020	274°55'12"	
	A4	PC	STA. 0+111.72	79TH. WAY N.E.	N85°04'48"W				21521.7688	270143.2086	274°55'12"	
A5	A5	PI	STA. 0+127.16	79TH. WAY N.E.		05°53'28"	300.00	15.44	30.85	21520.4449	270158.5883	
	A6	PT	STA. 0+142.57	79TH. WAY N.E.	N89°07'27"W				21520.7065	270174.0226	270°52'33"	
	A7	PC	STA. 0+072.39	LONG FELLOW ST.	N89°17'50"E				21625.9874	270004.0753	270°42'10"	
A8	A8	PI	STA. 0+077.48	LONG FELLOW ST.		38°34'09"	14.55	5.09	9.79	21626.0498	270009.1658	
	A9	PT	STA. 0+082.19	LONG FELLOW ST.	N50°43'42"E				21629.2724	270013.1070	309°16'18"	
	A10	PC	STA. 0+072.39	LIBERTY STREET	N89°00'36"E				21734.7178	269913.3049	270°59'24"	
A11	A11	PI	STA. 0+077.48	LIBERTY STREET		38°13'09"	31.00	10.74	20.68	21734.9151	269924.0436	
	A12	PT	STA. 0+082.19	LIBERTY STREET	N88°56'51"E				21741.7139	269932.3584	271°03'09"	
	A13	PC	STA. 0+091.53	ELY STREET	N88°56'49"E				21866.1637	269844.0056	271°03'11"	
A14	A14	PI	STA. 0+093.77	ELY STREET		19°10'44"	13.26	2.24	4.44	21866.2049	269846.2454	
	A15	PT	STA. 0+095.97	ELY STREET	N69°46'05"E				21866.9796	269848.3475	290°13'55"	
	A16	PC	STA. 0+123.99	IRONTON STREET	N74°01'42"E				22203.3092	269717.6977	285°58'18"	
A17	A17	PI	STA. 0+131.83	IRONTON STREET		14°39'30"	61.00	7.85	15.61	22205.4680	269725.2406	
	A18	PT	STA. 0+139.59	IRONTON STREET	N88°41'12"E				22205.6479	269733.0844	271°18'48"	
	A19	PC	STA. 0+147.04	IRONTON STREET	N88°41'12"E				22205.8186	269740.5298	271°18'48"	
A20	A20	PI	STA. 0+154.89	IRONTON STREET		14°39'30"	61.00	7.85	15.61	22205.9984	269748.3736	
	A21	PT	STA. 0+162.65	IRONTON STREET	N74°01'42"E				22208.1572	269755.9165	285°59'09"	

NO	DATE	BY	CKD	APPR	REVISION

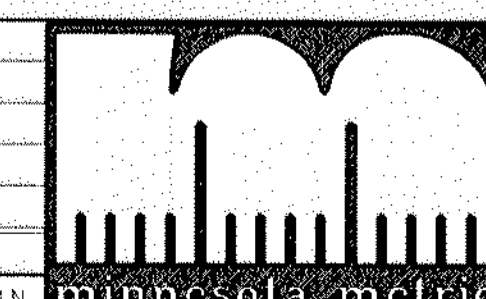

I HEREBY CERTIFY THAT THIS PLAN WAS PREPARED BY ME OR UNDER MY DIRECT SUPERVISION AND THAT I AM A DULY REGISTERED PROFESSIONAL ENGINEER UNDER THE LAWS OF THE STATE OF MINNESOTA.

DATE _____ REG. NO. _____

DRAWN BY _____ DATE _____
 DESIGN BY _____ DATE _____
 CHECKED BY _____ DATE _____



ANOKA COUNTY
HIGHWAY DEPT.

STATE PROJECT NO. 02-601-37
 STATE PROJECT NO. 127-020-20
 STATE PROJECT NO. 114-020-18
 COUNTY PROJECT NO. _____

ALIGNMENT TABULATION
 Sheet 15 of 93 Sheets

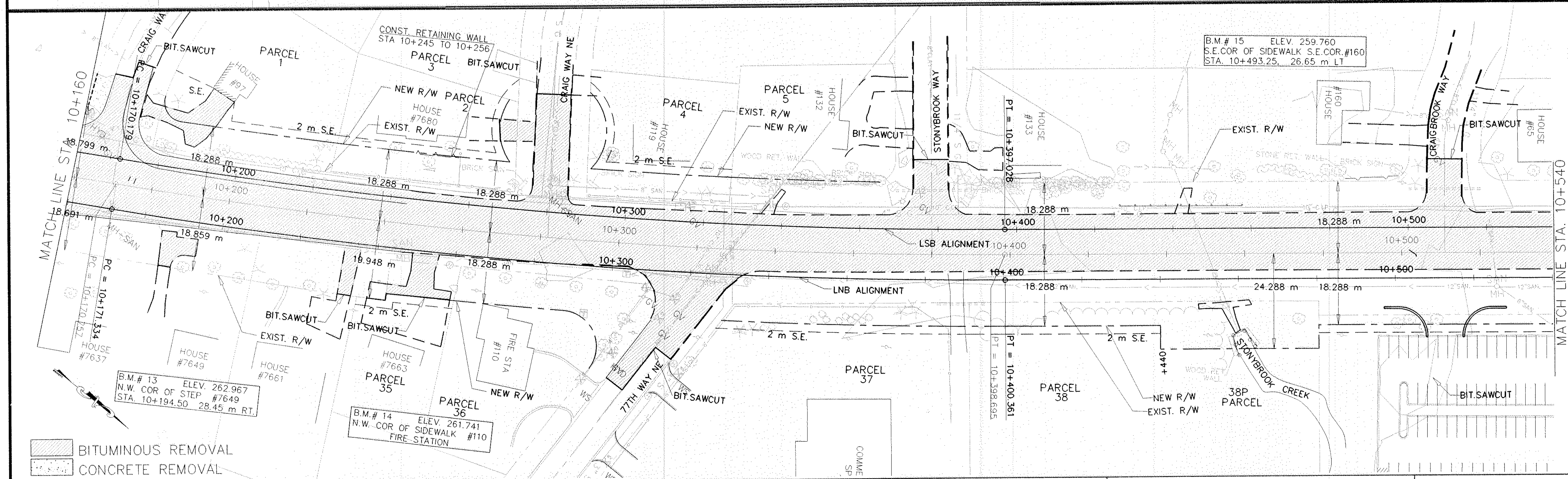
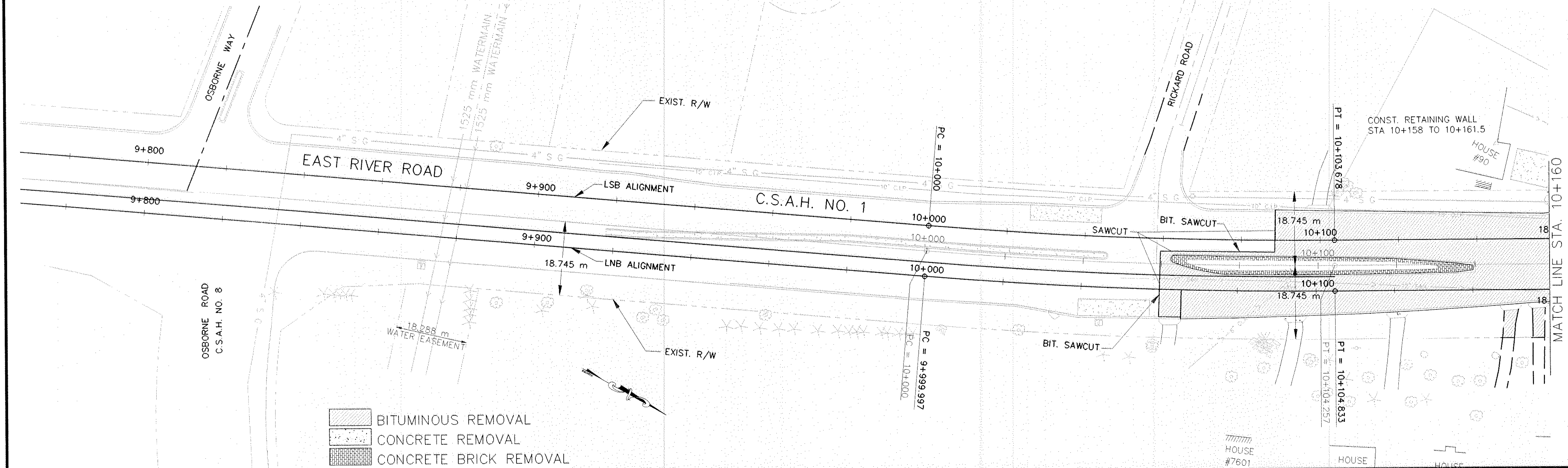

NO	DATE	BY	CKD	APPR	REVISION

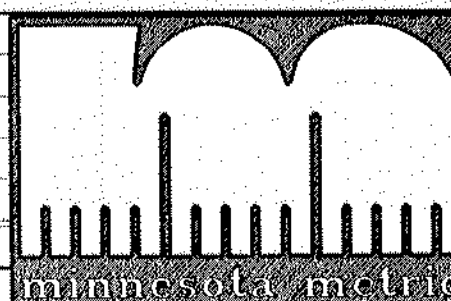

I HEREBY CERTIFY THAT THIS PLAN WAS PREPARED BY ME OR UNDER MY DIRECT SUPERVISION AND THAT I AM A DULY REGISTERED PROFESSIONAL ENGINEER UNDER THE LAWS OF THE STATE OF MINNESOTA.

DRAWN BY _____ DATE _____
 DESIGN BY _____ DATE _____
 CHECKED BY _____ DATE _____



**ANOKA COUNTY
HIGHWAY DEPT.**

STATE PROJECT NO. 02-601-37
 STATE PROJECT NO. 127-020-20
 STATE PROJECT NO. 114-020-18
 COUNTY PROJECT NO. _____

**EXISTING CONDITION
AND REMOVAL PLAN**
 STA. 9+800 TO STA. 10+540
 Sheet 16 of 93 Sheets

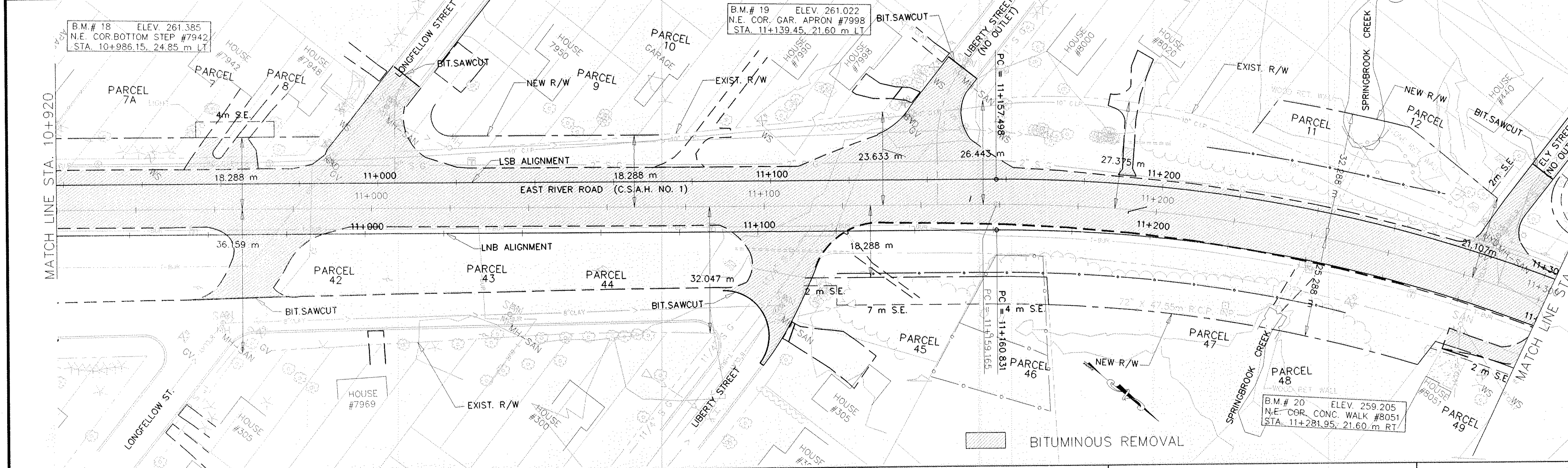
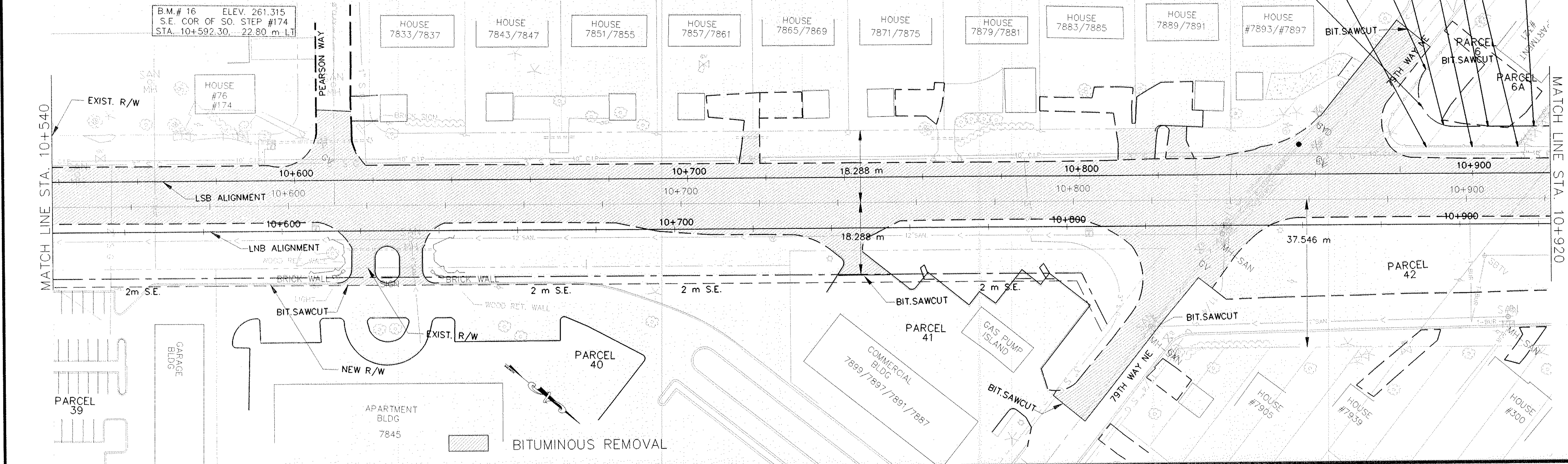

NO	DATE	BY	CKD	APPR	REVISION

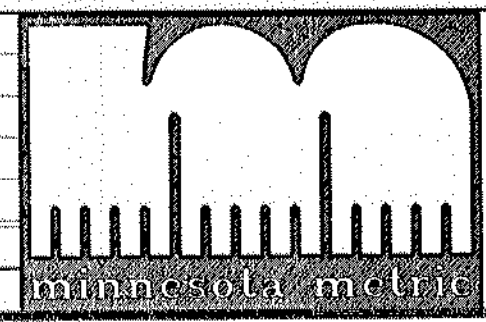

I HEREBY CERTIFY THAT THIS PLAN WAS PREPARED BY ME OR UNDER MY DIRECT SUPERVISION AND THAT I AM A DULY REGISTERED PROFESSIONAL ENGINEER UNDER THE LAWS OF THE STATE OF MINNESOTA.

DATE _____ REG. NO. _____

DRAWN BY _____ DATE _____
 DESIGN BY _____ DATE _____
 CHECKED BY _____ DATE _____



**ANOKA COUNTY
 HIGHWAY DEPT.**

STATE PROJECT NO. 02-601-37
 STATE PROJECT NO. 127-020-20
 STATE PROJECT NO. 114-020-18
 COUNTY PROJECT NO. _____

**EXISTING CONDITION
 AND REMOVAL PLAN**
 STA. 10+540 TO STA. 11+300
 Sheet 17 of 93 Sheets

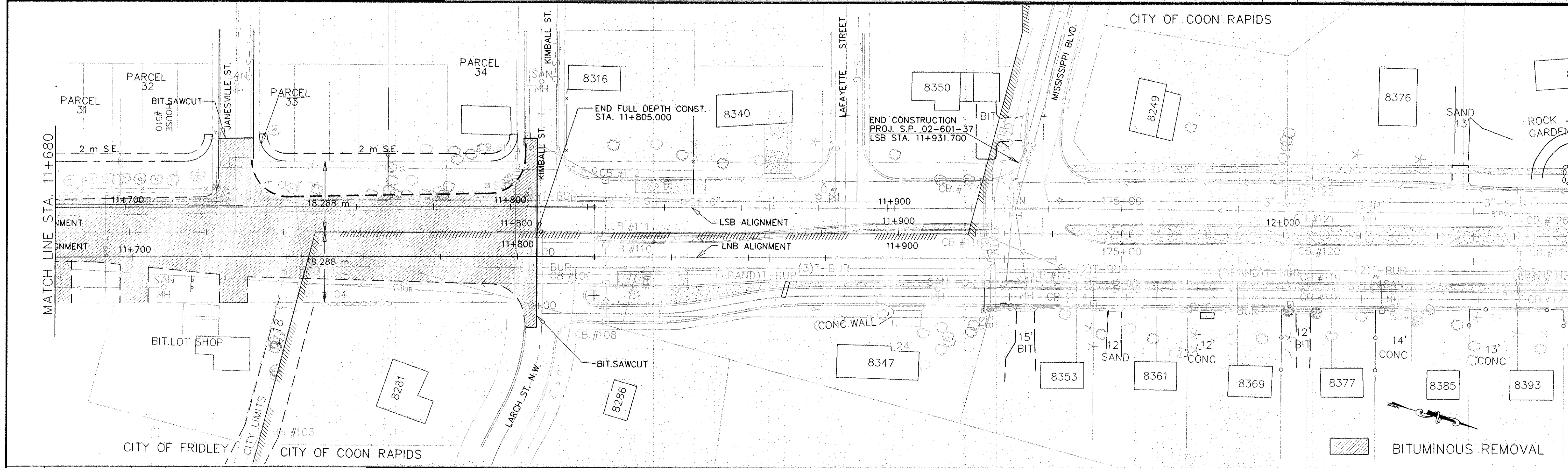
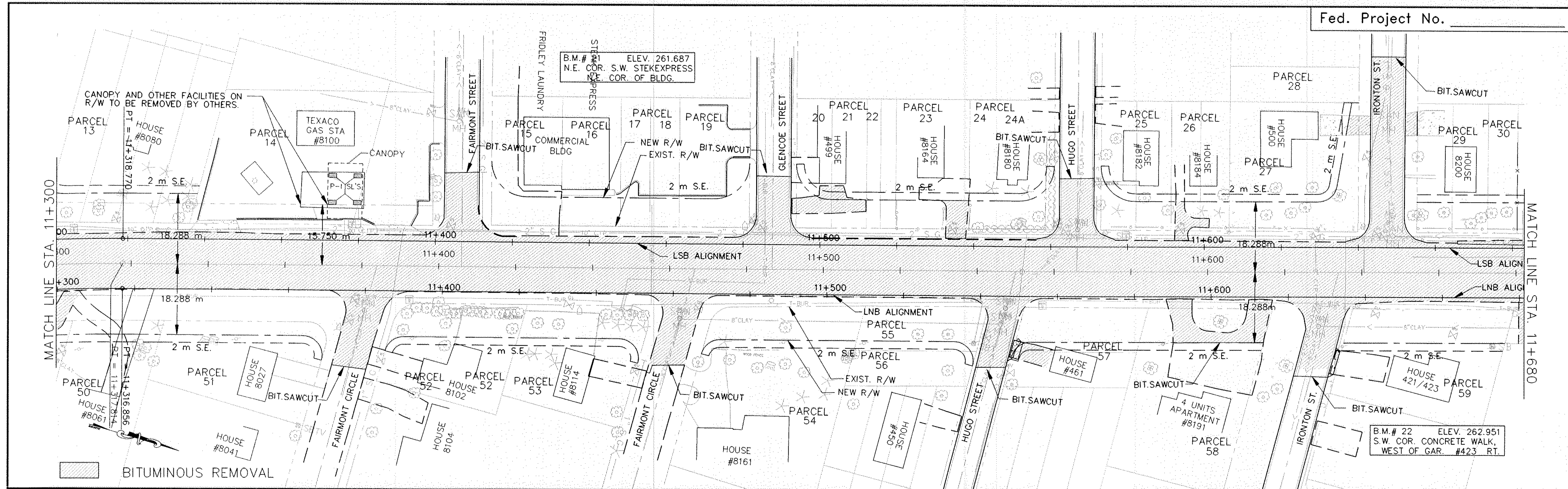

NO	DATE	BY	CKD	APPR	REVISION



I HEREBY CERTIFY THAT THIS PLAN WAS PREPARED BY ME OR UNDER MY DIRECT SUPERVISION AND THAT I AM A DULY REGISTERED PROFESSIONAL ENGINEER UNDER THE LAWS OF THE STATE OF MINNESOTA.

DATE _____ REG. NO. _____

DRAWN BY _____ DATE _____
 DESIGN BY _____ DATE _____
 CHECKED BY _____ DATE _____

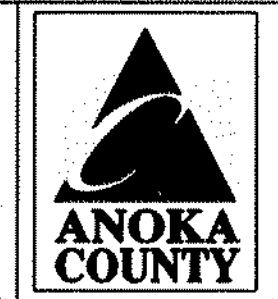

**ANOKA COUNTY
HIGHWAY DEPT.**

STATE PROJECT NO. 02-601-37
 STATE PROJECT NO. 127-020-20
 STATE PROJECT NO. 114-020-18
 COUNTY PROJECT NO. _____

**EXISTING CONDITION
AND REMOVAL PLAN**
 STA. 11+300 TO 11+931.700
 Sheet 18 of 93 Sheets

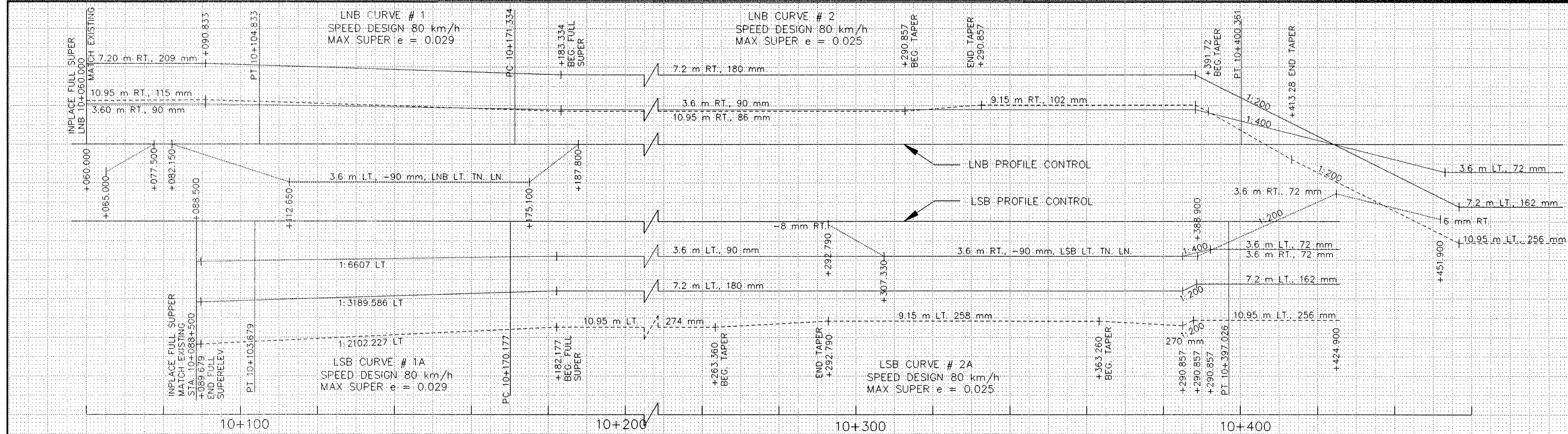
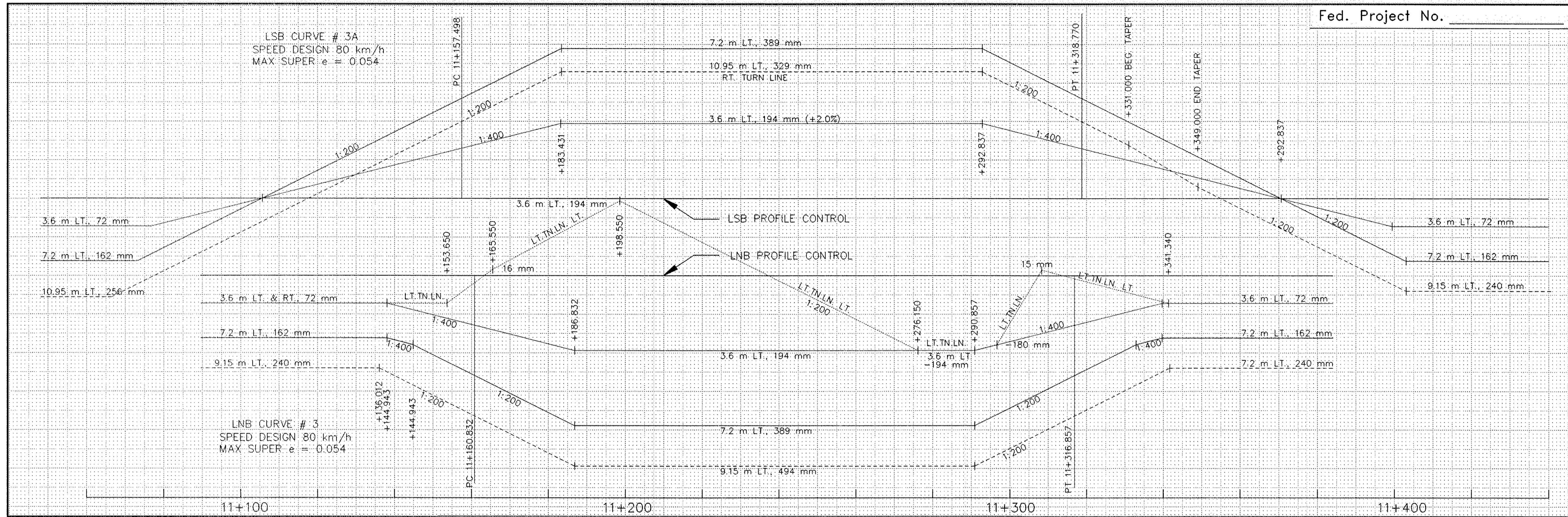

NO	DATE	BY	CKD	APPR	REVISION

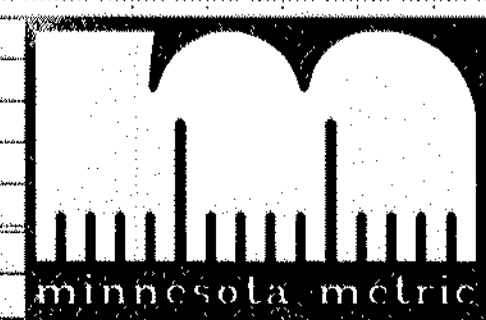

I HEREBY CERTIFY THAT THIS PLAN WAS PREPARED BY ME OR UNDER MY DIRECT SUPERVISION AND THAT I AM A DULY REGISTERED PROFESSIONAL ENGINEER UNDER THE LAWS OF THE STATE OF MINNESOTA.

DATE _____ REG. NO. _____

DRAWN BY: MN DATE _____
 DESIGN BY: DATE _____
 CHECKED BY: DATE _____

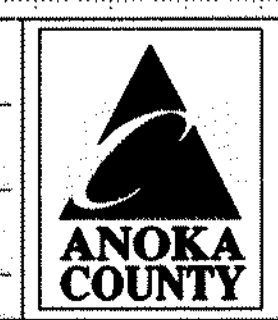

**ANOKA COUNTY
HIGHWAY DEPT.**

STATE PROJECT NO. 02-601-37
 STATE PROJECT NO. 127-020-20
 STATE PROJECT NO. 114-020-18
 COUNTY PROJECT NO. _____

SUPERELEVATION

Sheet 19 of 93 Sheets

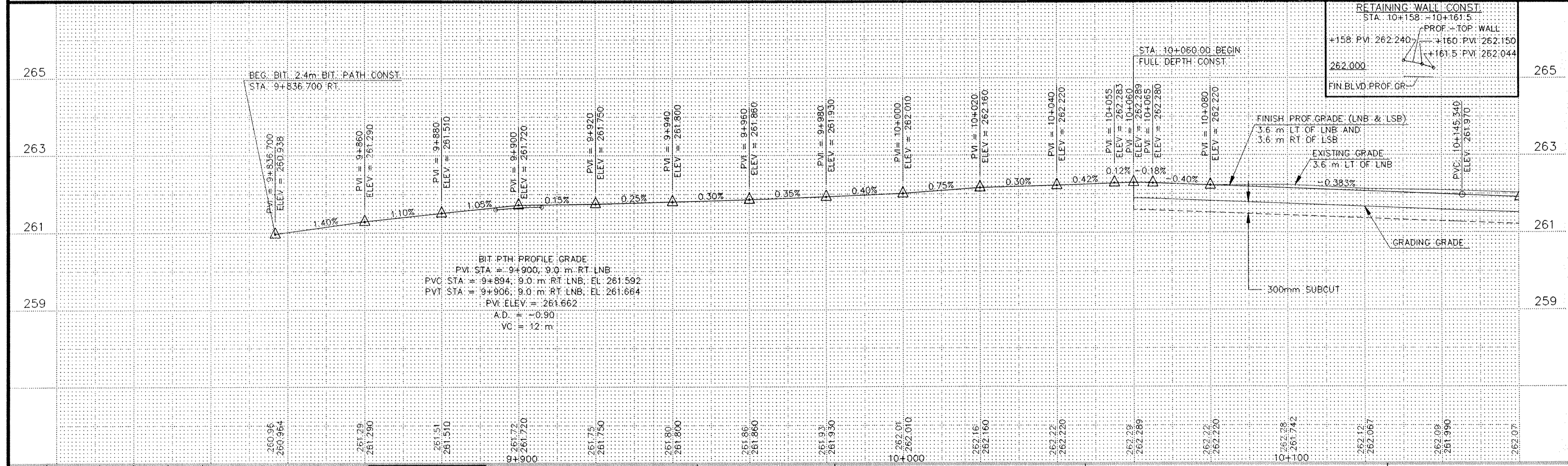
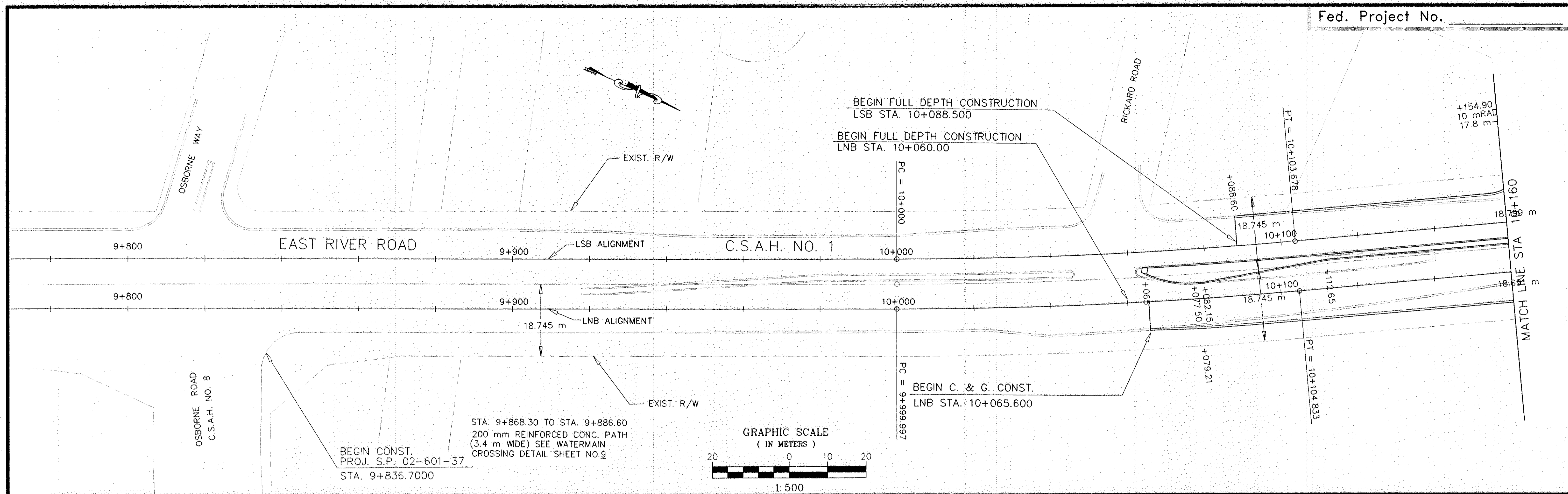

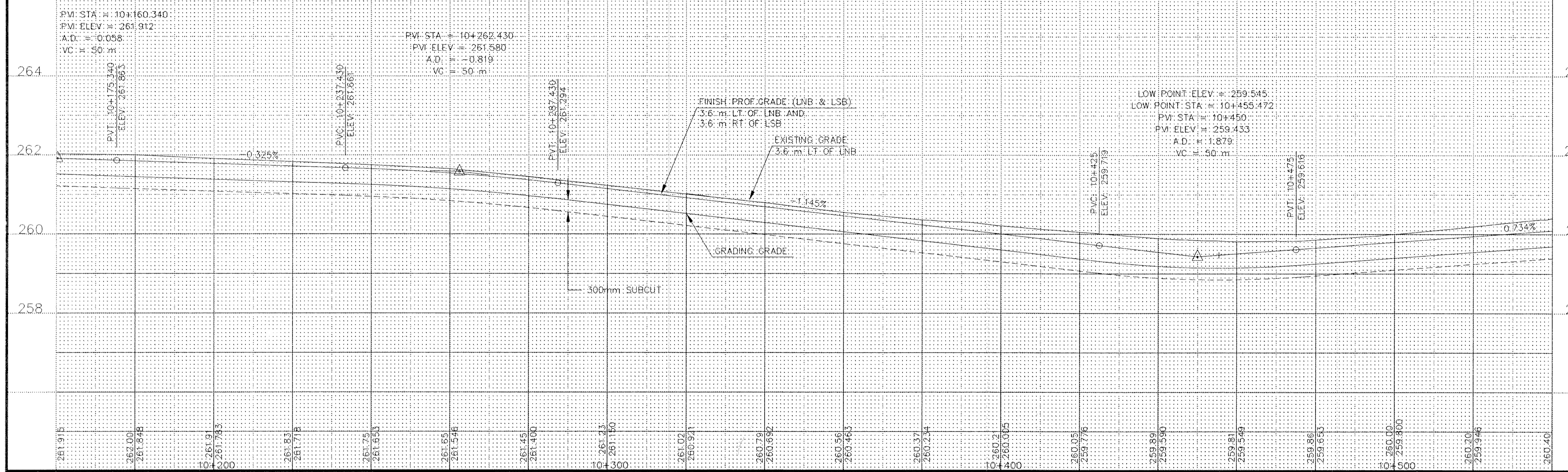
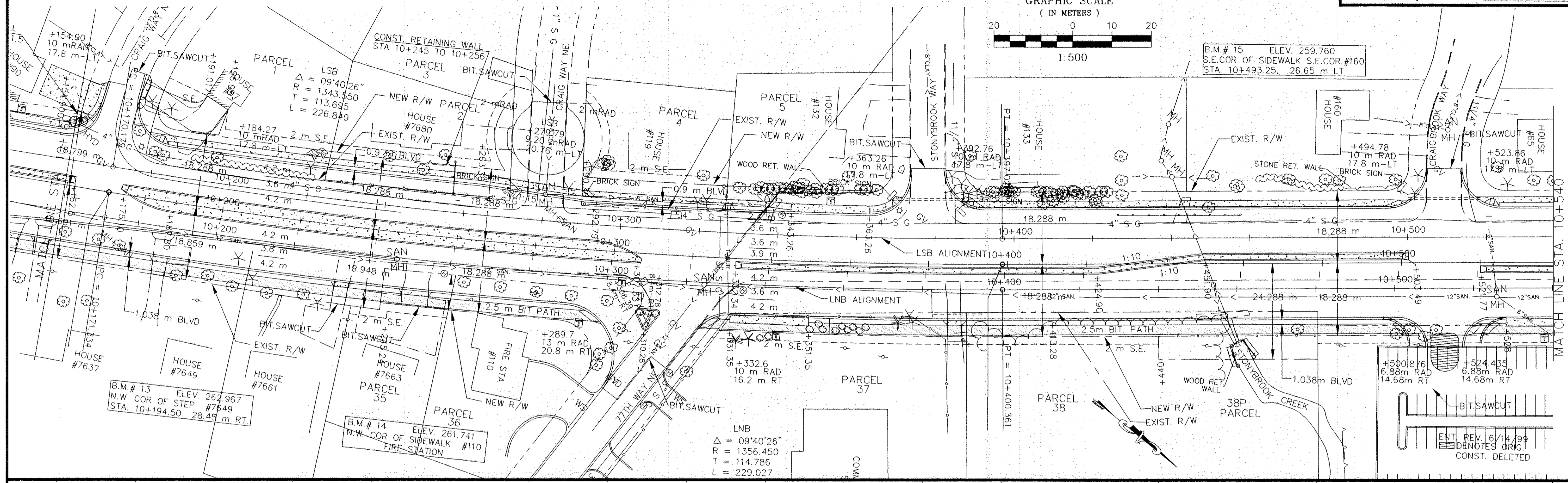
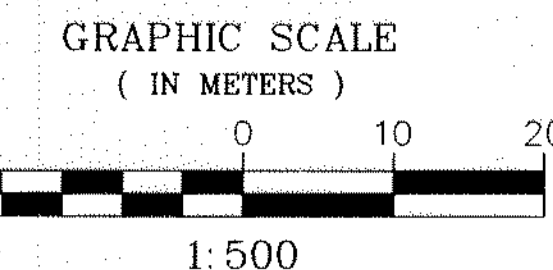

NO	DATE	BY	CKD	APPR	REVISION

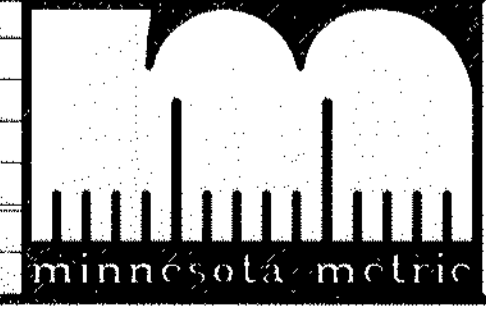

I HEREBY CERTIFY THAT THIS PLAN WAS PREPARED BY ME OR UNDER MY DIRECT SUPERVISION AND THAT I AM A DULY REGISTERED PROFESSIONAL ENGINEER UNDER THE LAWS OF THE STATE OF MINNESOTA.

DATE _____ REG. NO. _____

DRAWN BY: MN DATE 03/03/99
 DESIGN BY: KGJ DATE 03/03/99
 CHECKED BY: LR DATE 03/03/99

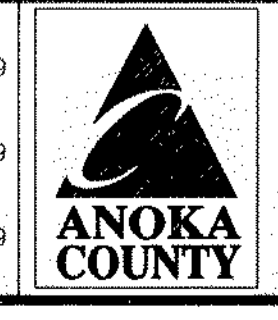

**ANOKA COUNTY
 HIGHWAY DEPT.**

STATE PROJECT NO. 02-601-37
 STATE PROJECT NO. 127-020-20
 STATE PROJECT NO. 114-020-18
 COUNTY PROJECT NO. _____

PLAN AND PROFILE
 STA. 10+160 TO STA. 10+540
 Sheet 21 of 93 Sheets

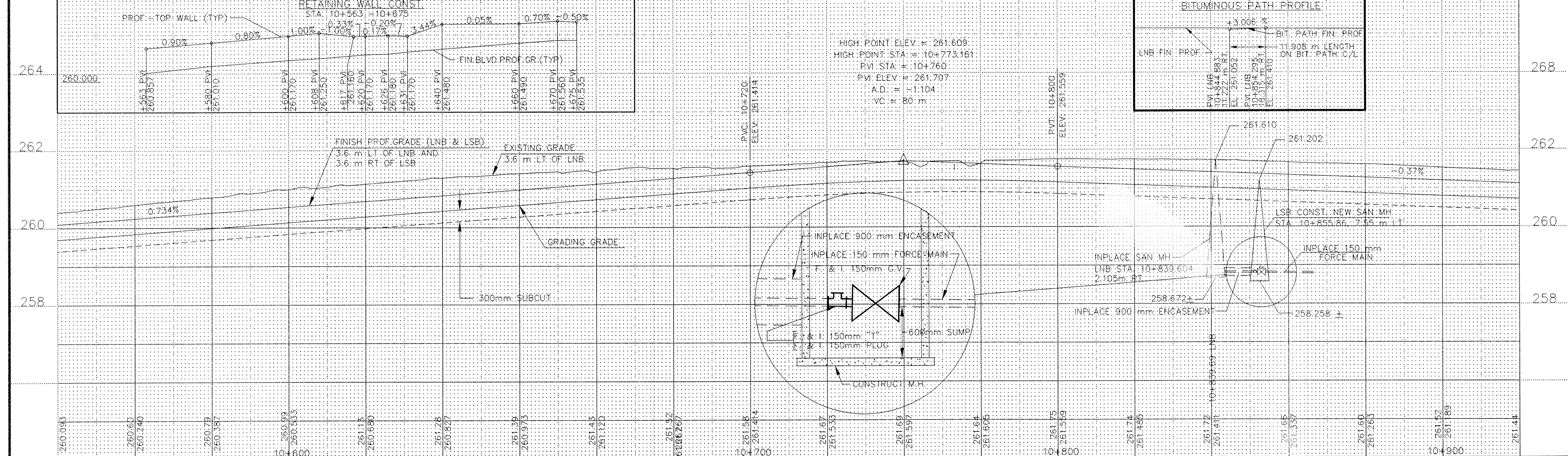
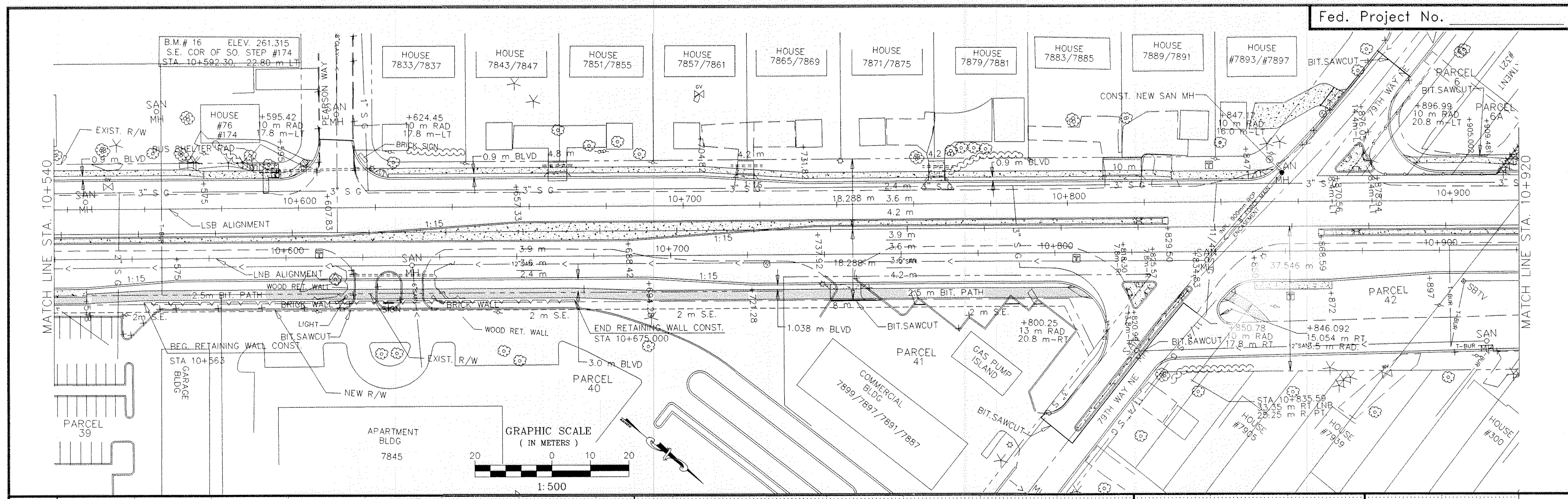

NO	DATE	BY	CKD	APPR	REVISION

I HEREBY CERTIFY THAT THIS PLAN WAS PREPARED BY ME OR UNDER MY DIRECT SUPERVISION AND THAT I AM A DULY REGISTERED PROFESSIONAL ENGINEER UNDER THE LAWS OF THE STATE OF MINNESOTA.

DRAWN BY: MN DATE 03/04/99
 DESIGN BY: KGJ DATE 03/04/99
 CHECKED BY: LR DATE 03/04/99

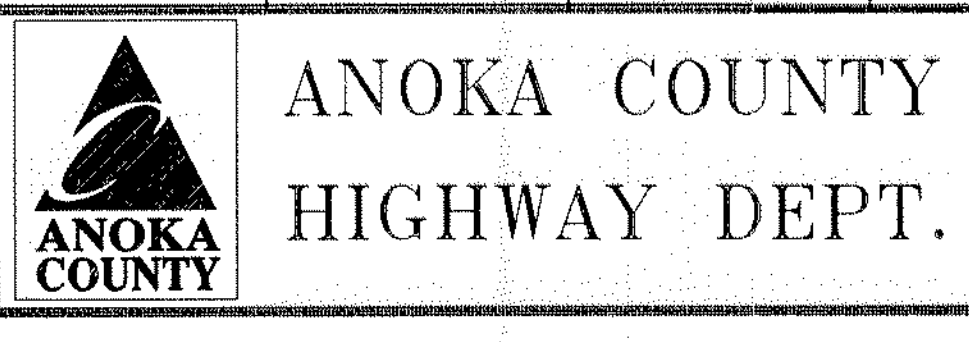

STATE PROJECT NO. 02-601-37
 STATE PROJECT NO. 127-020-20
 STATE PROJECT NO. 114-020-18
 COUNTY PROJECT NO.

PLAN AND PROFILE
 STA. 10+540 TO STA. 10+920
 Sheet 22 of 93 Sheets

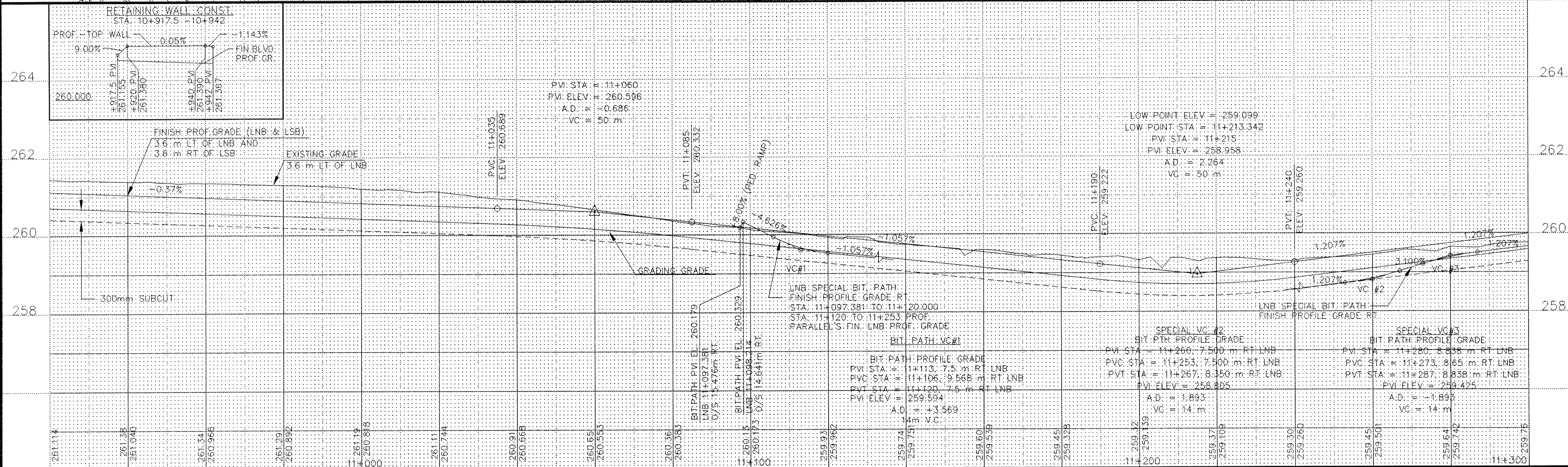
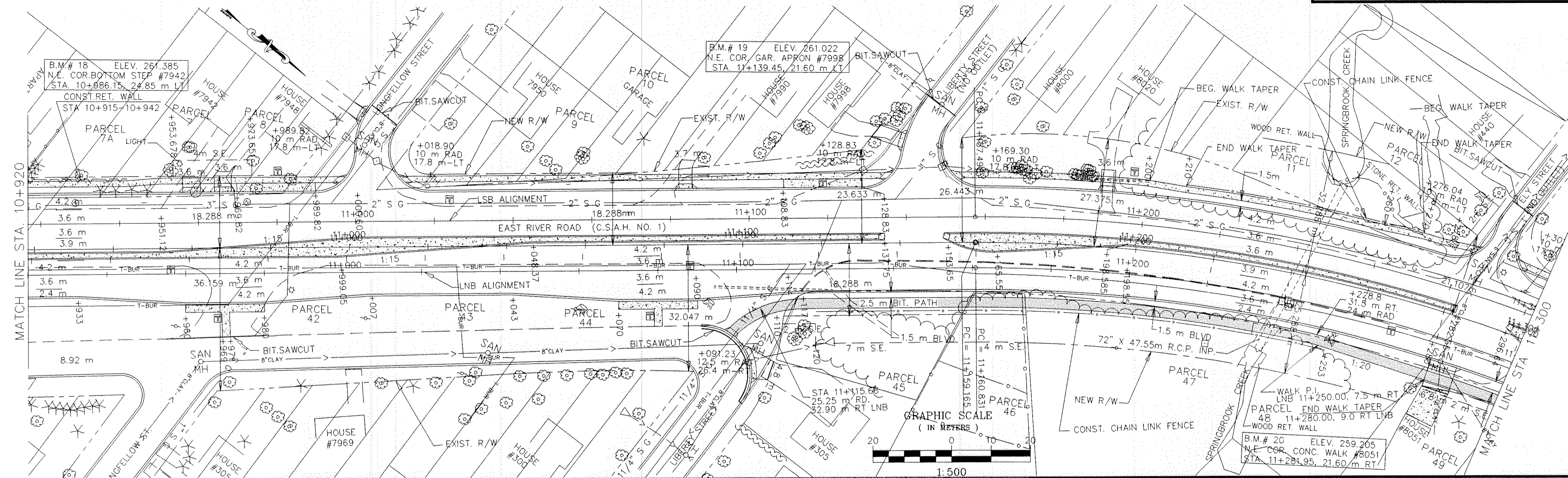

NO	DATE	BY	CKD	APPR	REVISION



I HEREBY CERTIFY THAT THIS PLAN WAS PREPARED BY ME OR UNDER MY DIRECT SUPERVISION AND THAT I AM A DULY REGISTERED PROFESSIONAL ENGINEER UNDER THE LAWS OF THE STATE OF MINNESOTA.

DATE _____ REG. NO. _____

DRAWN BY: MN DATE 03/04/99
 DESIGN BY: KGJ DATE 03/04/99
 CHECKED BY: LR DATE 03/04/99



ANOKA COUNTY
HIGHWAY DEPT.

STATE PROJECT NO. 02-601-37
 STATE PROJECT NO. 127-020-20
 STATE PROJECT NO. 114-020-18
 COUNTY PROJECT NO. _____

PLAN AND PROFILE
 STA. 10+920 TO STA. 11+300
 Sheet 23 of 93 Sheets

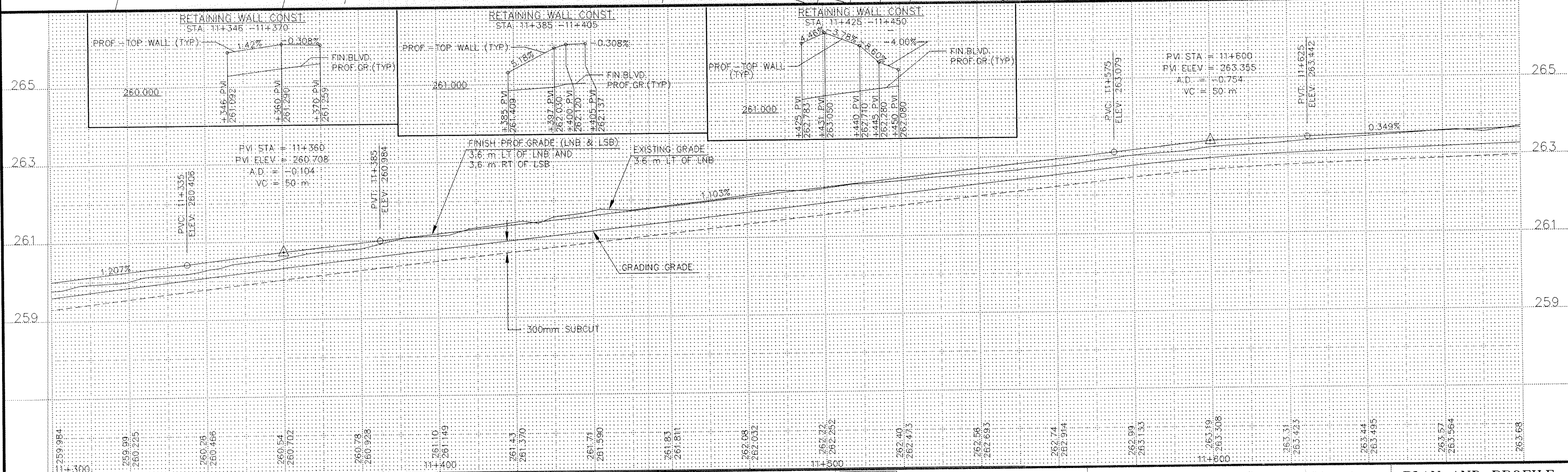
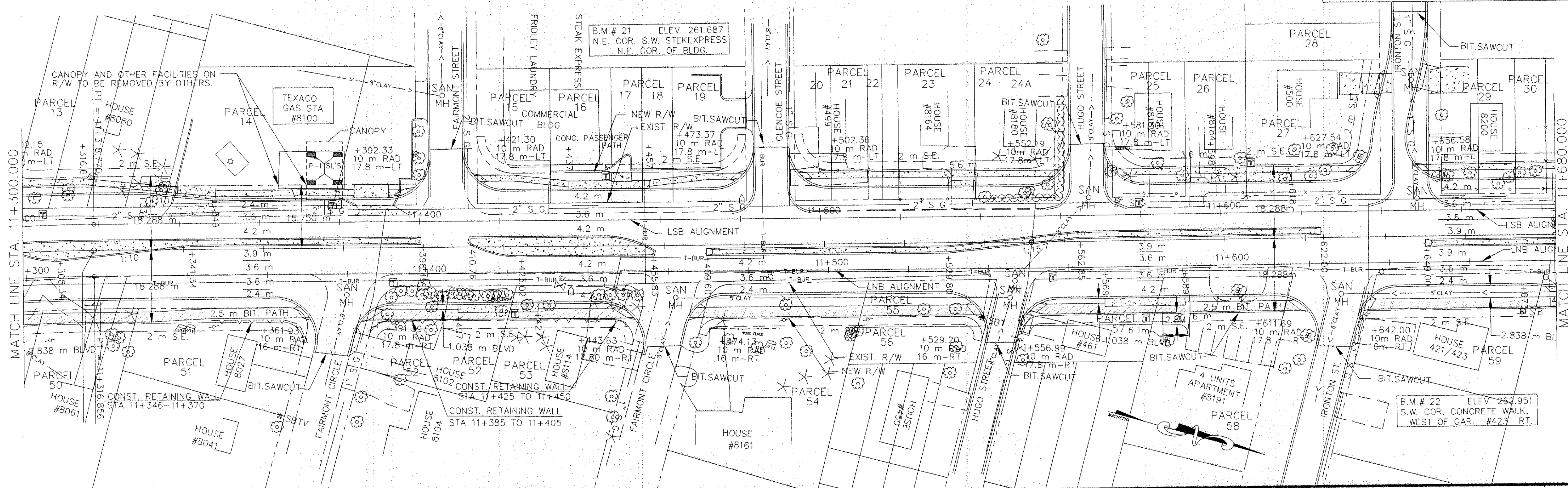

NO	DATE	BY	CKD	APPR	REVISION

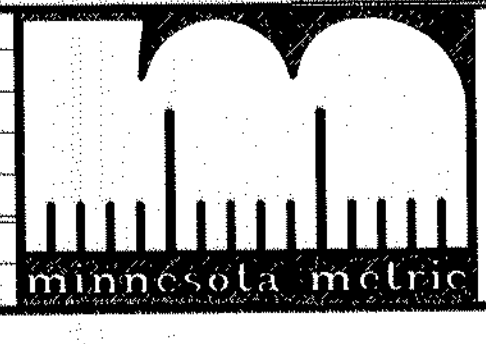

I HEREBY CERTIFY THAT THIS PLAN WAS PREPARED BY ME OR UNDER MY DIRECT SUPERVISION AND THAT I AM A DULY REGISTERED PROFESSIONAL ENGINEER UNDER THE LAWS OF THE STATE OF MINNESOTA.

DATE _____ REG. NO. _____

DRAWN BY: MN DATE 03/04/99
 DESIGN BY: KGJ DATE 03/04/99
 CHECKED BY: LR DATE 03/04/99



**ANOKA COUNTY
HIGHWAY DEPT.**

STATE PROJECT NO. 02-601-37
 STATE PROJECT NO. 127-020-20
 STATE PROJECT NO. 114-020-18
 COUNTY PROJECT NO. _____

PLAN AND PROFILE
 STA. 11+300 TO STA. 11+680
 Sheet 24 of 93 Sheets

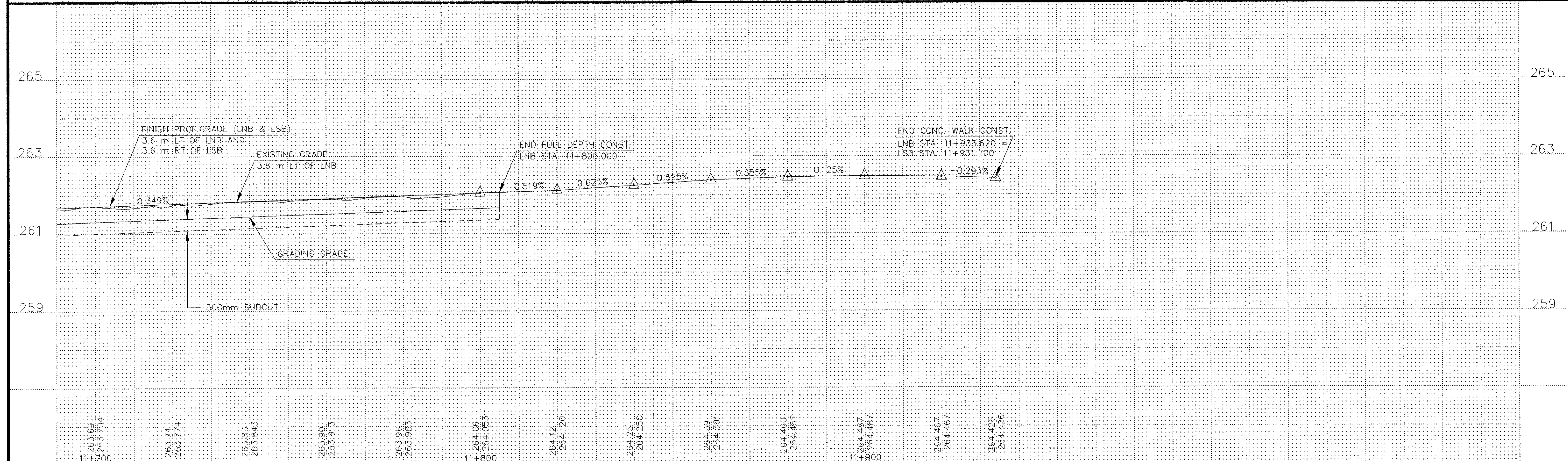
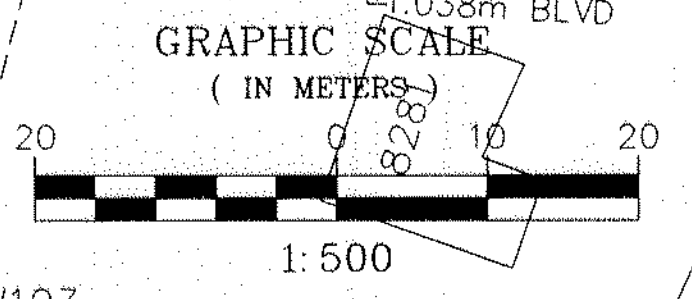
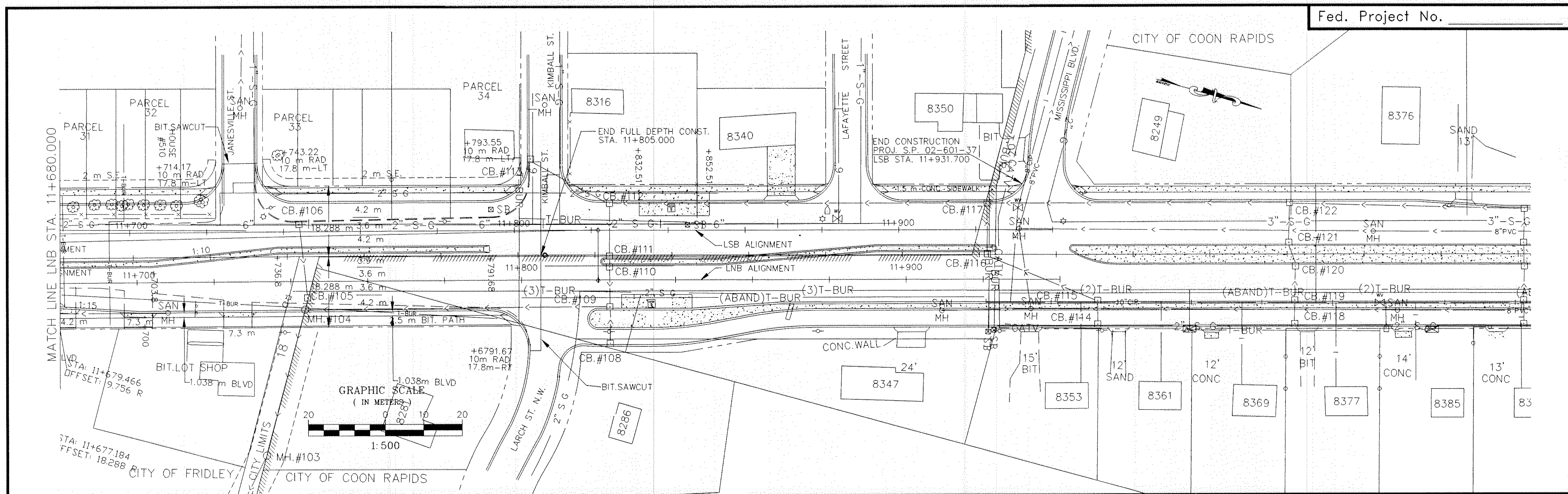

NO	DATE	BY	CKD	APPR	REVISION

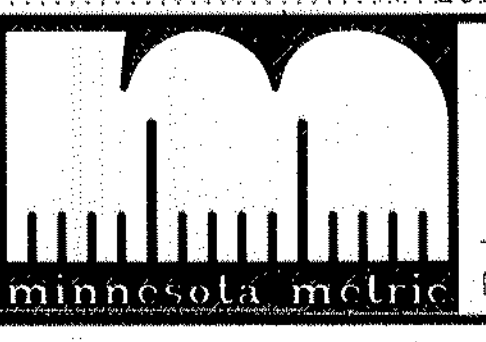

I HEREBY CERTIFY THAT THIS PLAN WAS PREPARED BY ME OR UNDER MY DIRECT SUPERVISION AND THAT I AM A DULY REGISTERED PROFESSIONAL ENGINEER UNDER THE LAWS OF THE STATE OF MINNESOTA.

DATE _____ REG. NO. _____

DRAWN BY MN DATE 03/04/99
 DESIGN BY KGJ DATE 03/04/99
 CHECKED BY LR DATE 03/04/99



ANOKA COUNTY
HIGHWAY DEPT.

STATE PROJECT NO. 02-601-37
 STATE PROJECT NO. 127-020-20
 STATE PROJECT NO. 114-020-18
 COUNTY PROJECT NO. _____

PLAN AND PROFILE
 STA. 11+680 TO STA. 11+805
 Sheet 25 of 93 Sheets

ALIGNMENT	STA - STA	OFFSET	ITEM	REMOVE				ADJUST	NOTES
				MH OR CB (EACH)	PIPE SEWER (m)	APRON (EACH)	PIPE CULVERT (m)		
LNB ALIGNMENT	10+372.7-10+390.5	22.5 LT - 23.0 LT	450 mm CMP				19.5		
LNB ALIGNMENT	10+440.8	32.5 LT	MANHOLE						1
LNB ALIGNMENT	10+443.5	28.4 LT	MANHOLE						1
LNB ALIGNMENT	10+440.8-10+443.5	32.5 LT - 29.4 LT	1200 mm RCP						1
LNB ALIGNMENT	10+443.5-10+460.0	29.4 LT - 14.9 RT	1200 mm RCP		46.2				
LNB ALIGNMENT	10+446.1	79.5 LT	MANHOLE						1
LNB ALIGNMENT	10+442.5	41.8 LT	CATCH BASIN						1
LNB ALIGNMENT	10+440.8-10+442.5	32.5 LT - 41.8 LT	1500 mm RCP						1
LNB ALIGNMENT	10+442.5-10+446.1	41.8 LT - 79.5 LT	1500 mm RCP						1
LNB ALIGNMENT	10+435.7-10+443.5	23.9 LT-28.4 LT	375 mm RCP				9.0		
LNB ALIGNMENT	10+443.5-10+452.8	28.4 LT-25.7 LT	375 mm RCP				10.5		
LNB ALIGNMENT	10+503.7-10+522.2	22.8 LT - 22.8 LT	450 mm CMP				18.3		
LNB ALIGNMENT	10+592.4-10+623.3	22.7 LT - 23.0 LT	450 mm CMP				30.9		
LNB ALIGNMENT	10+667.3-10+675.2	23.4 LT - 23.6 LT	375 mm CMP				7.8		
LNB ALIGNMENT	10+716.5-10+724.5	23.3 LT - 23.3 LT	375 mm CMP				8.4		
LNB ALIGNMENT	10+764.0-10+773.5	23.8 LT - 23.8 LT	375 mm CMP				9.6		
LNB ALIGNMENT	10+787.0	58.8 RT	CATCH BASIN	1					
LNB ALIGNMENT	10+793.9	64.8 RT	MANHOLE	1					
LNB ALIGNMENT	10+797.1	66.5 RT	CATCH BASIN	1					
LNB ALIGNMENT	10+787.0-10+797.1	58.8 RT - 66.5 RT	300 mm RCP				12.8		
LNB ALIGNMENT	10+784.8-10+793.9	75.0 RT - 64.8 RT	375 mm RCP		14.5				
LNB ALIGNMENT	10+810.5-10+831.2	23.6 LT - 23.7 LT	450 mm CMP				21.7		
LNB ALIGNMENT	11+000.6	34.5 LT	CATCH BASIN	1					
LNB ALIGNMENT	11+008.4	28.0 LT	CATCH BASIN	1					
LNB ALIGNMENT	11+021.6	21.7 LT	MANHOLE	1					
LNB ALIGNMENT	11+132.5	24.8 LT	CATCH BASIN	1					
LNB ALIGNMENT	11+152.0	25.9 LT	CATCH BASIN	1					
LNB ALIGNMENT	11+000.6 - 11+008.4	34.5 LT - 28.0 LT	300 mm RCP		9.8				
LNB ALIGNMENT	11+008.4 - 11+021.6	28.0 LT - 21.7 LT	300 mm RCP		15.0				
LNB ALIGNMENT	11+021.6 - 11+132.5	21.7 LT - 24.8 LT	300 mm RCP		111.0				
LNB ALIGNMENT	11+132.5 - 11+152.0	24.8 LT - 25.9 LT	300 mm RCP		19.5				
LNB ALIGNMENT	11+152.0 - 11+171.0	25.9 LT - 24.2 LT	300 mm RCP & APRON		17.8	1			
LNB ALIGNMENT	11+070.8 - 11+089.3	35.4 RT - 48.8 RT	300 mm RCP & APRON		20.8	1			
LNB ALIGNMENT	11+081.2	42.4 RT	CATCH BASIN	1					
LNB ALIGNMENT	11+086.8	46.8 RT	MANHOLE	1					
LNB ALIGNMENT	11+089.3	48.8 RT	CATCH BASIN	1					
LNB ALIGNMENT	11+086.8 + 11+106.0	46.5 RT - 21.8 RT	600 mm RCP & APRON		30.5	1			
LNB ALIGNMENT	11+106.0 + 11+124.7	21.8 RT - 18.1 RT	600 mm RCP & APRON		18.7	1			
LNB ALIGNMENT	11+095.7 - 11+120.0	10.5 RT - 18.2 RT	450 mm CMP				25.5		
LNB ALIGNMENT	11+177.5 - 11+180.0	32.0 RT - 60.0 RT	375 mm RCP & APRON		26.2	1			
LNB ALIGNMENT	11+235.5 - 11+248.5	13.5 RT - 29.5 LT	1800 mm RCP & APRON			1	45.3		
LNB ALIGNMENT	11+730.0 - 11+743.4	52.5 RT - 7.4 RT	525 mm RCP		48.5				
LNB ALIGNMENT	11+743.4 - 11+742.3	7.4 RT - 16.5 LT	525 mm RCP		24.2				
LNB ALIGNMENT	11+742.3	16.5 LT	CATCH BASIN	1					
LNB ALIGNMENT	11+743.8	6.0 RT	CATCH BASIN	1					
LNB ALIGNMENT	11+743.4	7.4 RT	MANHOLE					1	2
LNB ALIGNMENT	11+802.3	31.7 LT	CATCH BASIN	1					
LNB ALIGNMENT	11+823.0	19.5 LT	CATCH BASIN	1					
LNB ALIGNMENT	11+802.3 - 11+823.0	31.7 LT - 19.5 LT	300 mm RCP				24.2		
LNB ALIGNMENT	11+823.0	19.5 LT - 17.0 RT	525 mm RCP				36.0		
LNB ALIGNMENT	11+823.0	6.5 LT	CATCH BASIN	1					
LNB ALIGNMENT	11+823.0	3.0 LT	CATCH BASIN	1					
LNB ALIGNMENT	11+823.0	7.0 RT	CATCH BASIN	1					
LNB ALIGNMENT	11+823.0	16.0 RT	CATCH BASIN	1					
TOTALS				19	462.9	6	219.3	1	

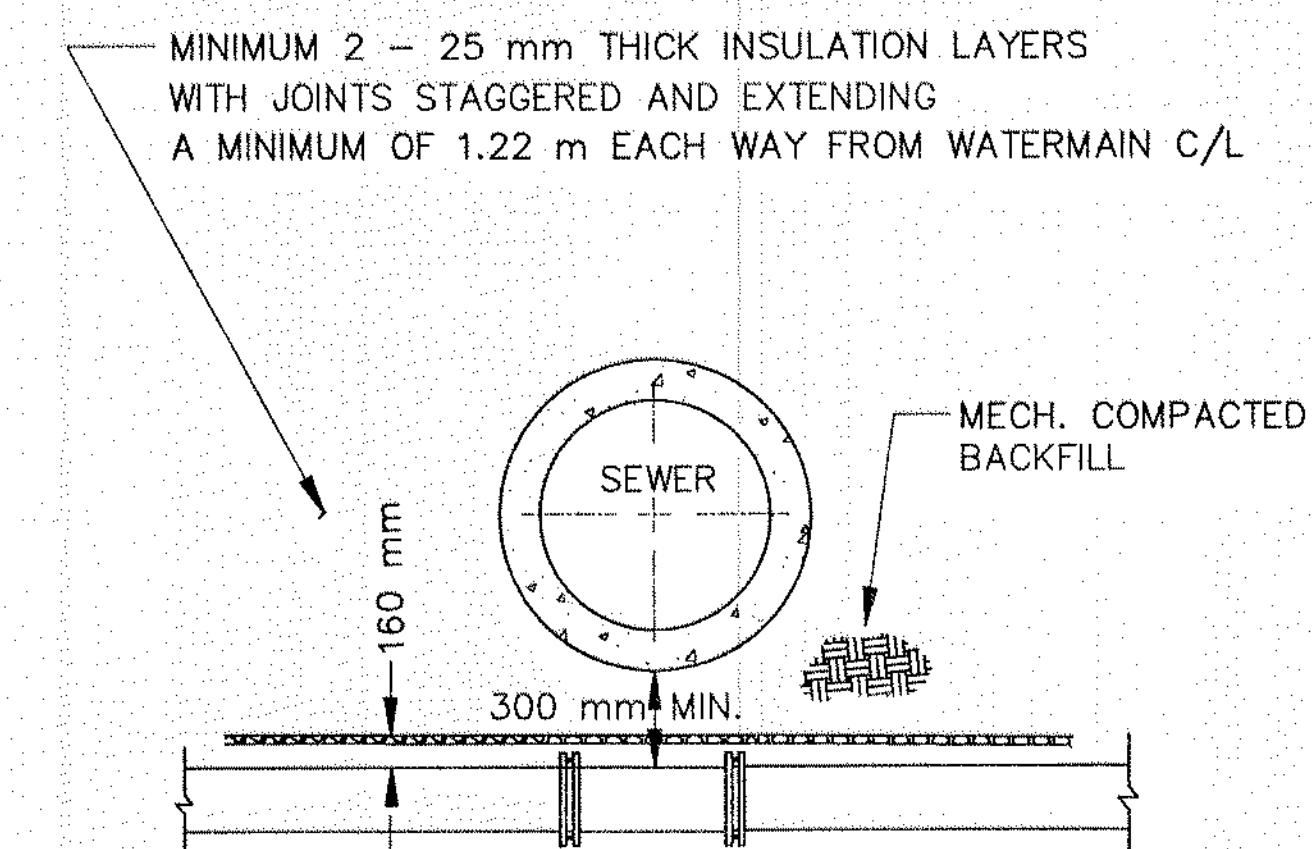

WATERMAIN INSULATION

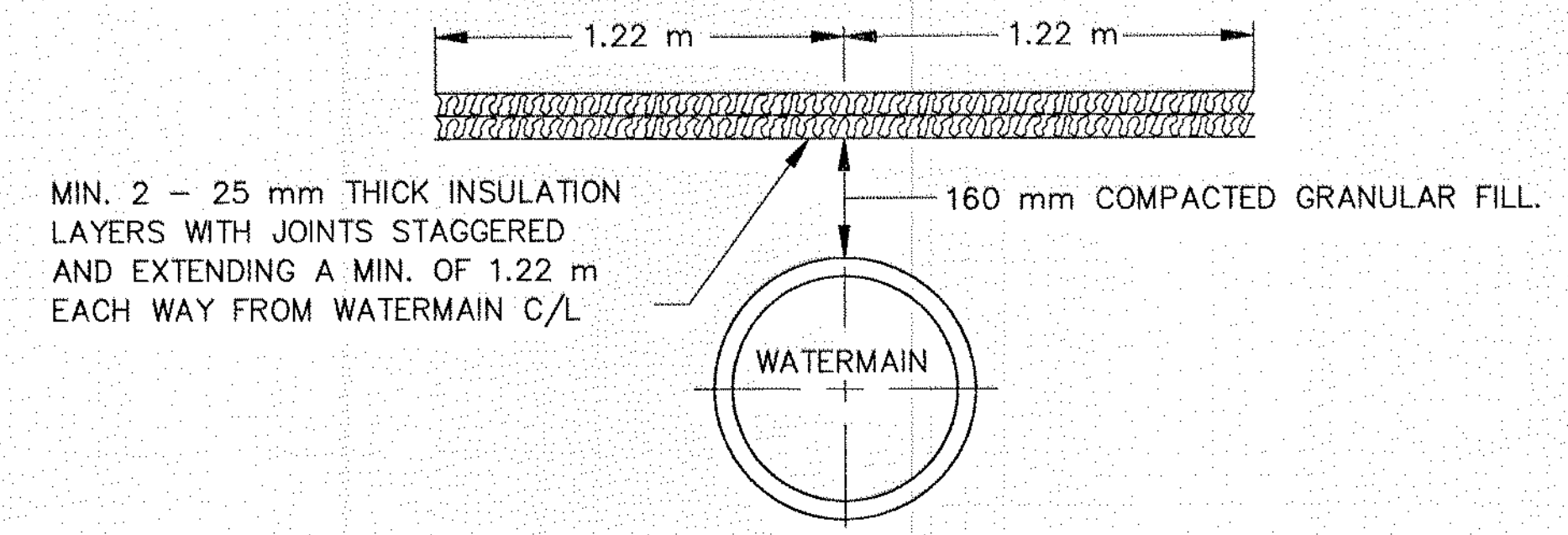

GENERAL STORM SEWER NOTES:
 PROVIDE STEPS IN ALL DRAINAGE STRUCTURES GREATER THAN 1.2 m IN DEPTH. STEPS WILL BE CONSIDERED INCIDENTAL TO DRAINAGE STRUCTURE CONSTRUCTION.
 DRAINAGE STRUCTURE LOCATIONS ARE GIVEN AT CENTER OF GRATE CASTING. TOP OF CASTING ELEVATIONS ARE MEASURED AT FLOW LINES.
 PIPE APRON LOCATIONS AND ELEVATIONS ARE GIVEN AT END OF APRON.
 PROVIDE INSULATION FOR EXISTING WATERMAINS WITHIN 600 mm PROXIMITY OF PROPOSED STORM SEWER PIPES. SEE DETAIL ABOVE.

- NOTES:
 1. LEAVE AS IS
 2. REMOVE EXISTING MANHOLE CASTING (INCIDENTAL) AND REPLACE WITH CASTING ASSEMBLY B-1, ADJUST TO FIT CURB. TC=263.742

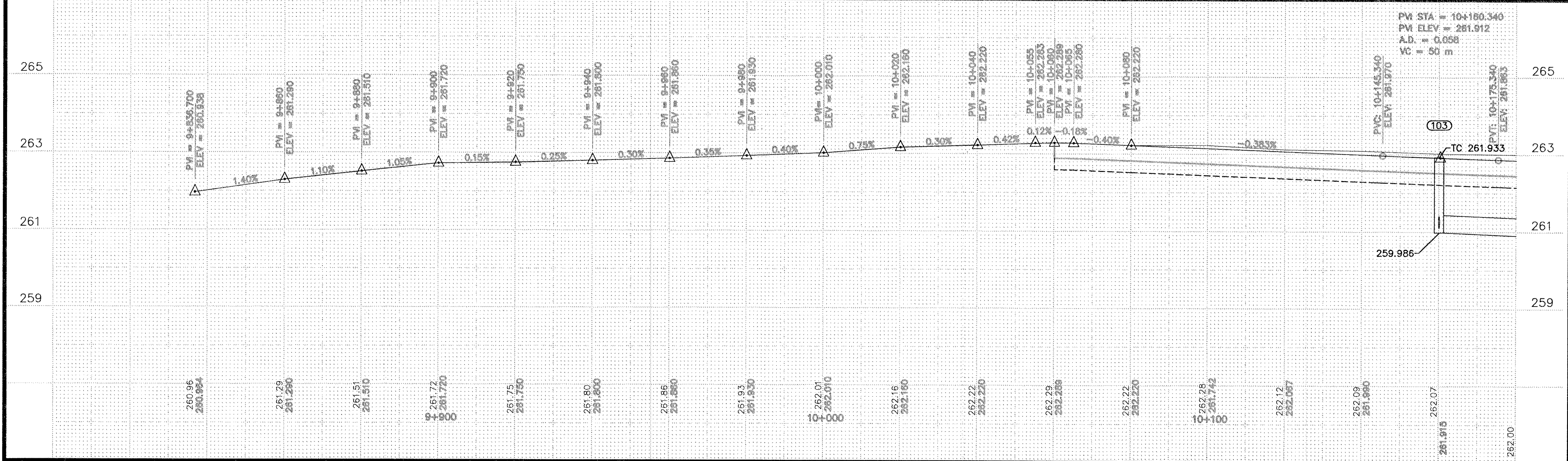
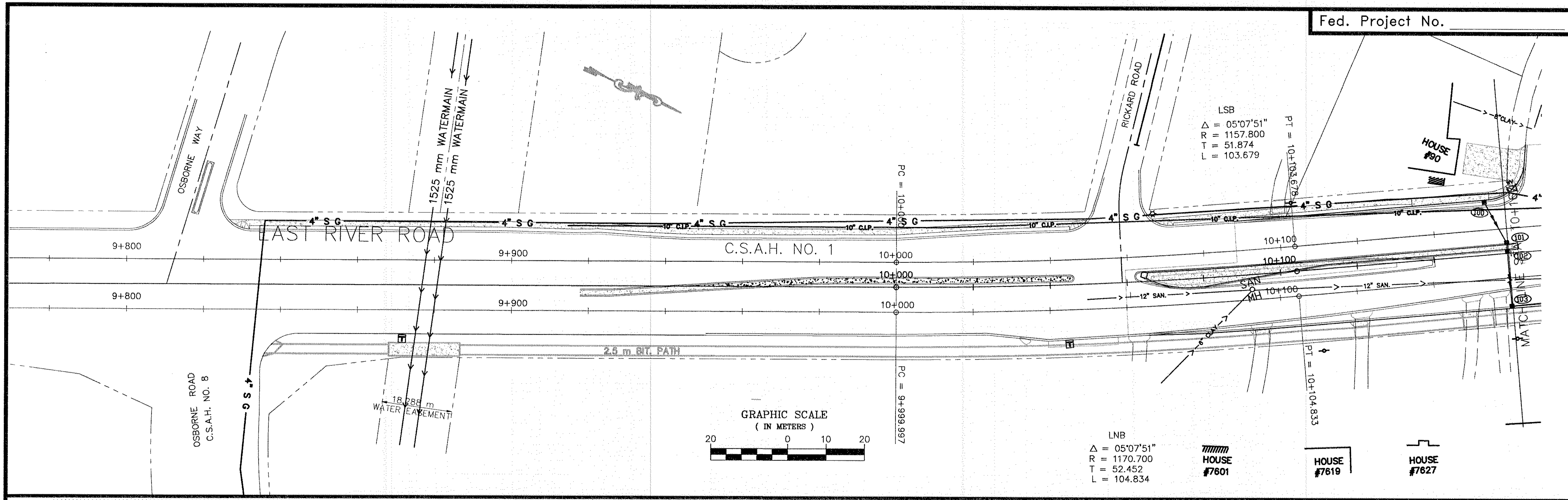

NO	DATE	BY	CKD	APPR	REVISION

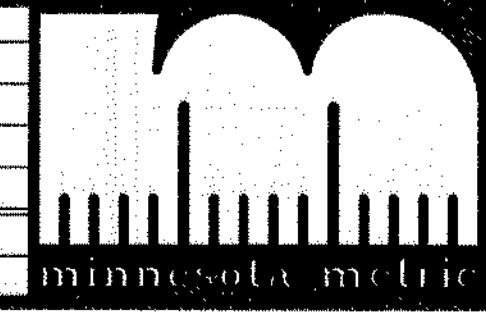

I HEREBY CERTIFY THAT THIS PLAN WAS PREPARED BY ME OR UNDER MY DIRECT SUPERVISION AND THAT I AM A DULY REGISTERED PROFESSIONAL ENGINEER UNDER THE LAWS OF THE STATE OF MINNESOTA.

DATE _____ REG. NO. _____



ANOKA COUNTY
HIGHWAY DEPT.

STATE PROJECT NO. 02-601-37
 STATE PROJECT NO. 127-020-20
 STATE PROJECT NO. 114-020-18
 COUNTY PROJECT NO. _____

DRAINAGE PLAN
AND PROFILE
 STA. 880+000 TO STA. 10+160
 Sheet 29 of 93 Sheets

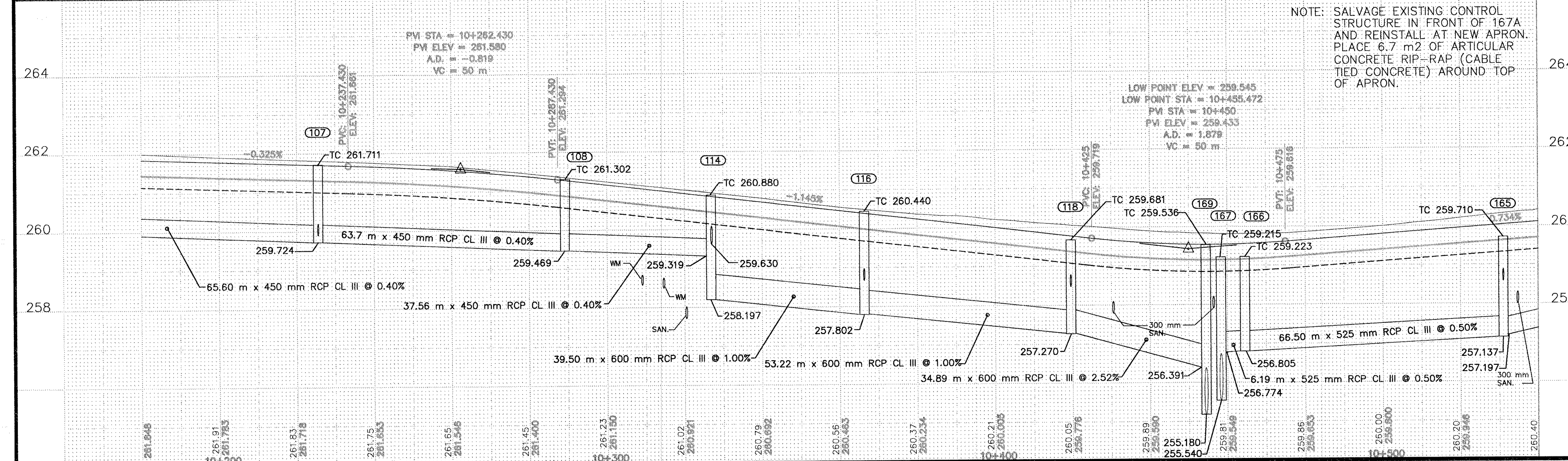
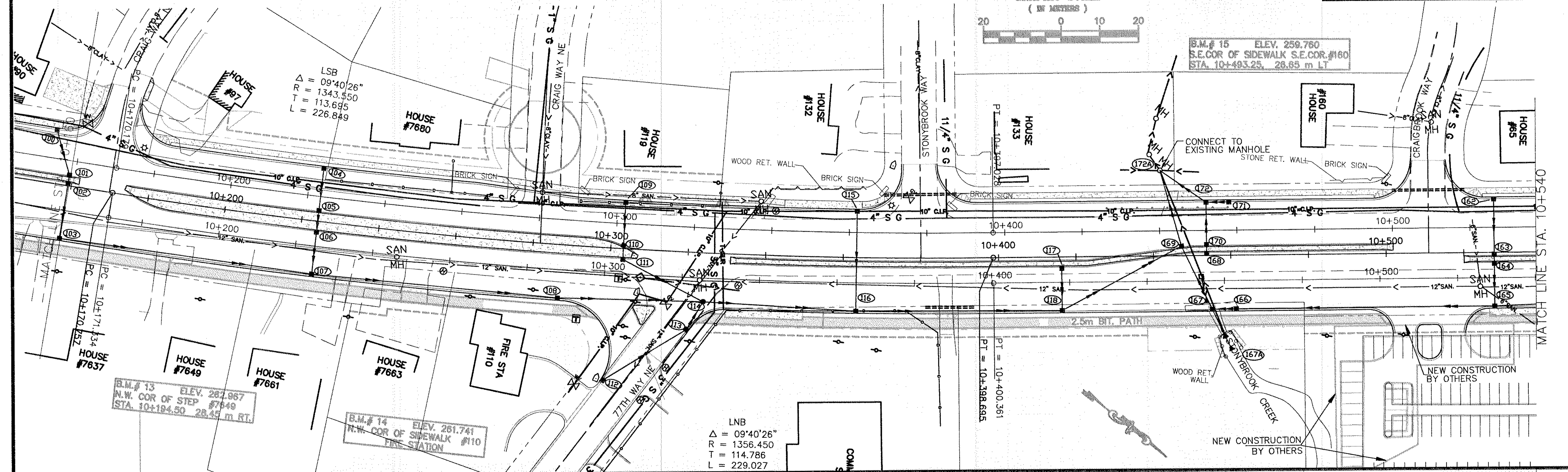
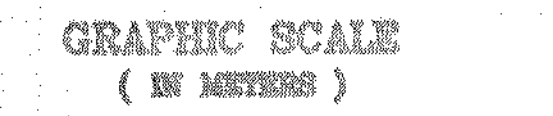

NOTE: SALVAGE EXISTING CONTROL STRUCTURE IN FRONT OF 167A AND REINSTALL AT NEW APRON. PLACE 6.7 m² OF ARTICULAR CONCRETE RIP-RAP (CABLE TIED CONCRETE) AROUND TOP OF APRON.

NO	DATE	BY	CKD	APPR	REVISION



I HEREBY CERTIFY THAT THIS PLAN WAS PREPARED BY ME OR UNDER MY DIRECT SUPERVISION AND THAT I AM A DULY REGISTERED PROFESSIONAL ENGINEER UNDER THE LAWS OF THE STATE OF MINNESOTA.

DATE _____ REG. NO. _____



ANOKA COUNTY HIGHWAY DEPT.

STATE PROJECT NO. 02-601-37
 STATE PROJECT NO. 127-020-20
 STATE PROJECT NO. 114-020-18
 COUNTY PROJECT NO. _____

DRAINAGE PLAN AND PROFILE
 STA. 10+160 TO STA. 10+540
 Sheet 30 of 93 Sheets

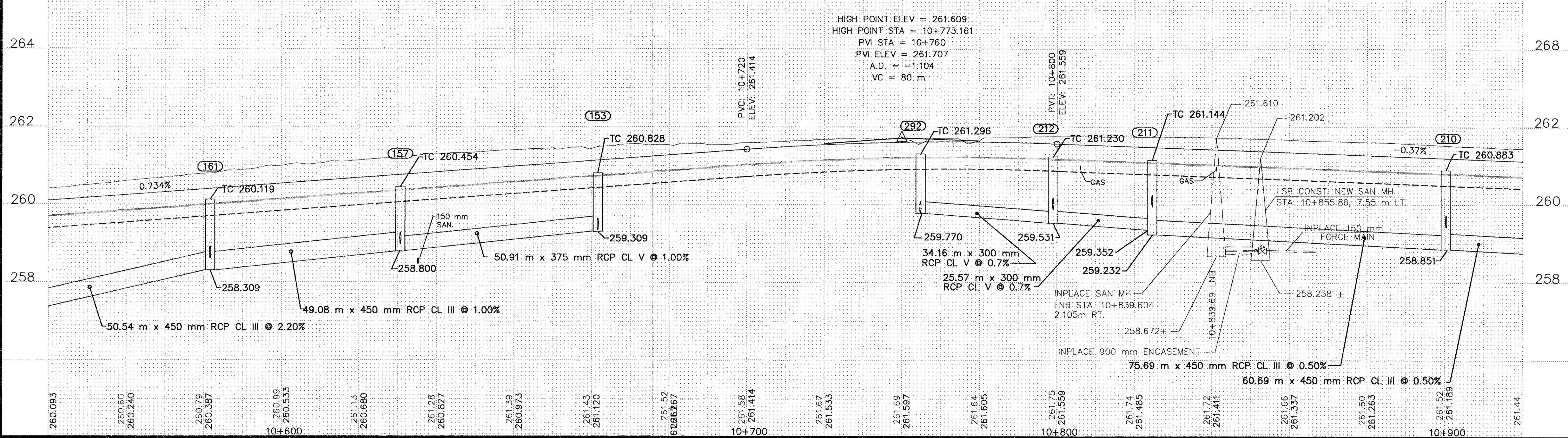
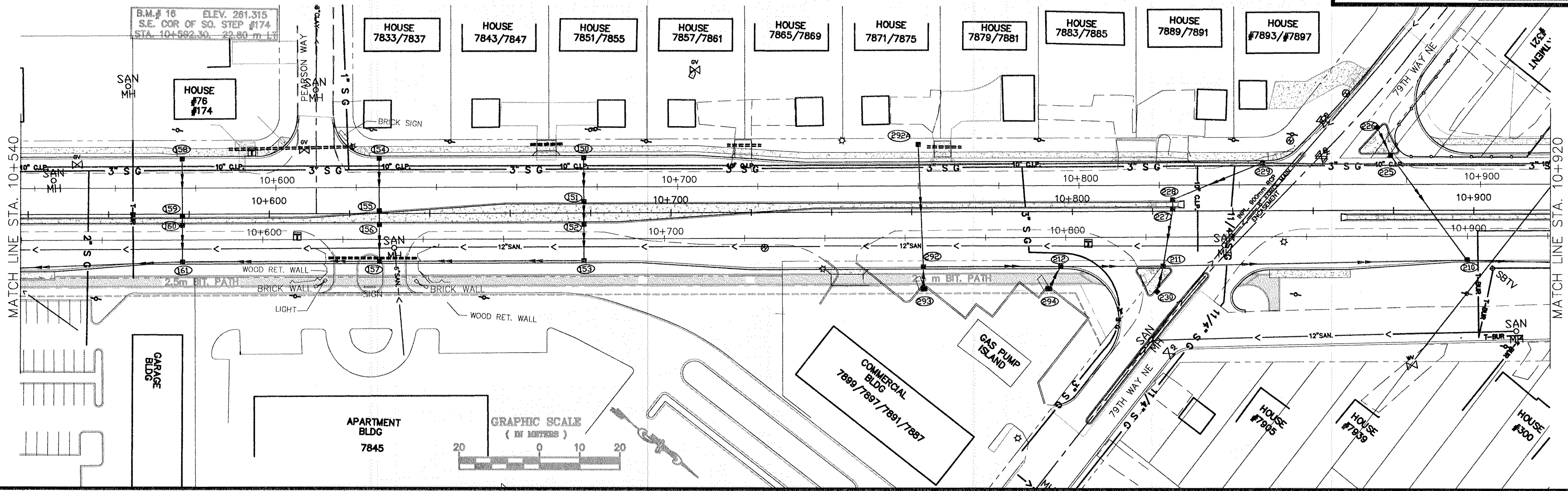

NO	DATE	BY	CKD	APPR	REVISION

NAME: 22-PlanP.dwg 81098 35051



I HEREBY CERTIFY THAT THIS PLAN WAS PREPARED BY ME OR UNDER MY DIRECT SUPERVISION AND THAT I AM A DULY REGISTERED PROFESSIONAL ENGINEER UNDER THE LAWS OF THE STATE OF MINNESOTA.

DATE _____ REG. NO. _____



ANOKA COUNTY HIGHWAY DEPT.

STATE PROJECT NO. 02-601-37
STATE PROJECT NO. 127-020-20
STATE PROJECT NO. 114-020-18
COUNTY PROJECT NO. _____

DRAINAGE PLAN AND PROFILE
STA. 10+540 TO STA. 10+920
Sheet 31 of 93 Sheets

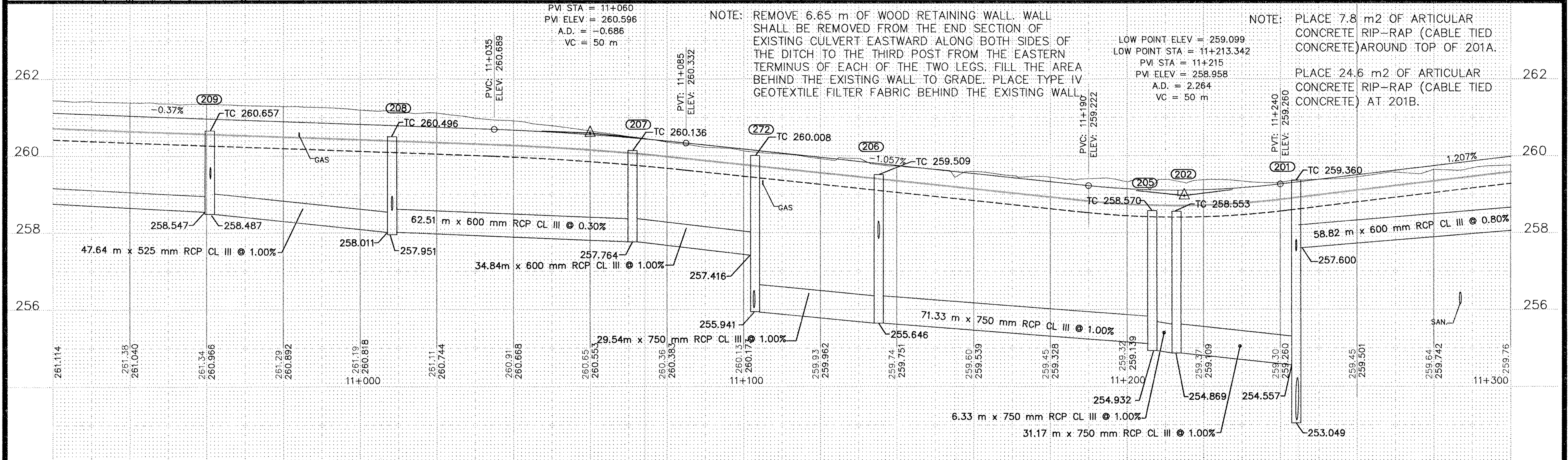
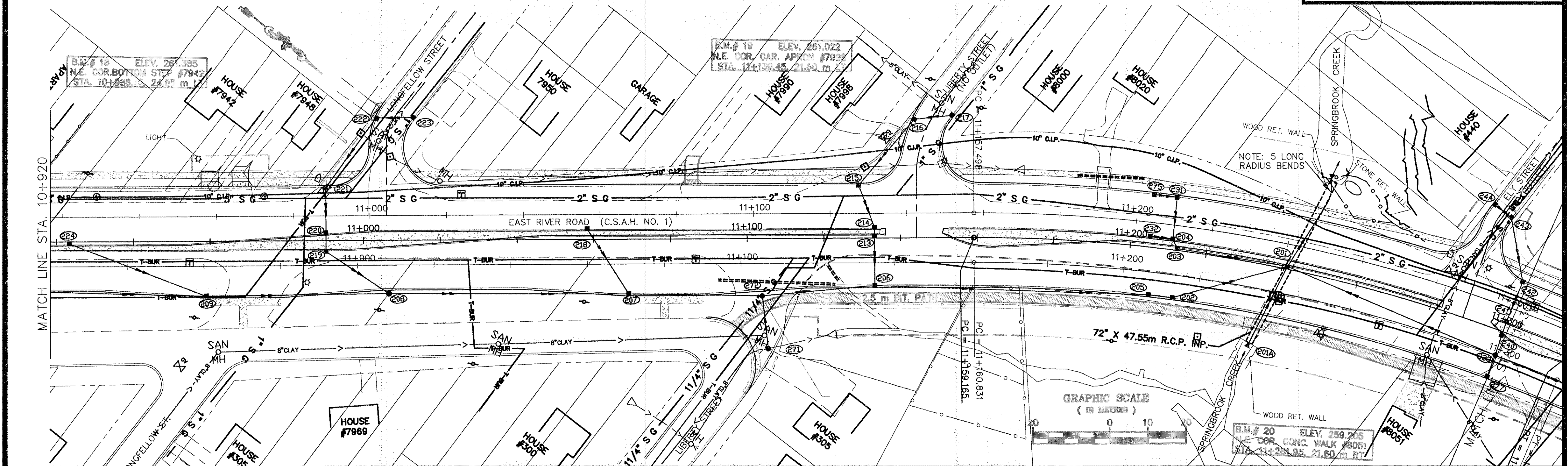

NO	DATE	BY	CKD	APPR	REVISION

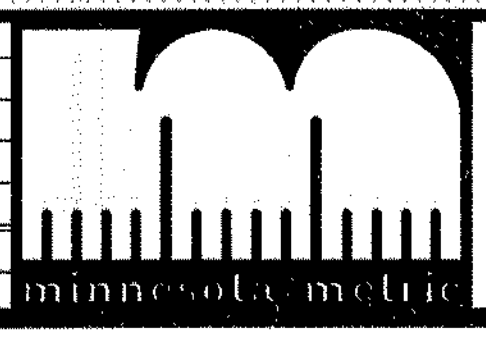

I HEREBY CERTIFY THAT THIS PLAN WAS PREPARED BY ME OR UNDER MY DIRECT SUPERVISION AND THAT I AM A DULY REGISTERED PROFESSIONAL ENGINEER UNDER THE LAWS OF THE STATE OF MINNESOTA.

DATE _____ REG. NO. _____



ANOKA COUNTY
HIGHWAY DEPT.

STATE PROJECT NO. 02-601-37
STATE PROJECT NO. 127-020-20
STATE PROJECT NO. 114-020-18
COUNTY PROJECT NO. _____

DRAINAGE PLAN
AND PROFILE
STA. 10+920 TO STA. 11+300
Sheet 32 of 93 Sheets

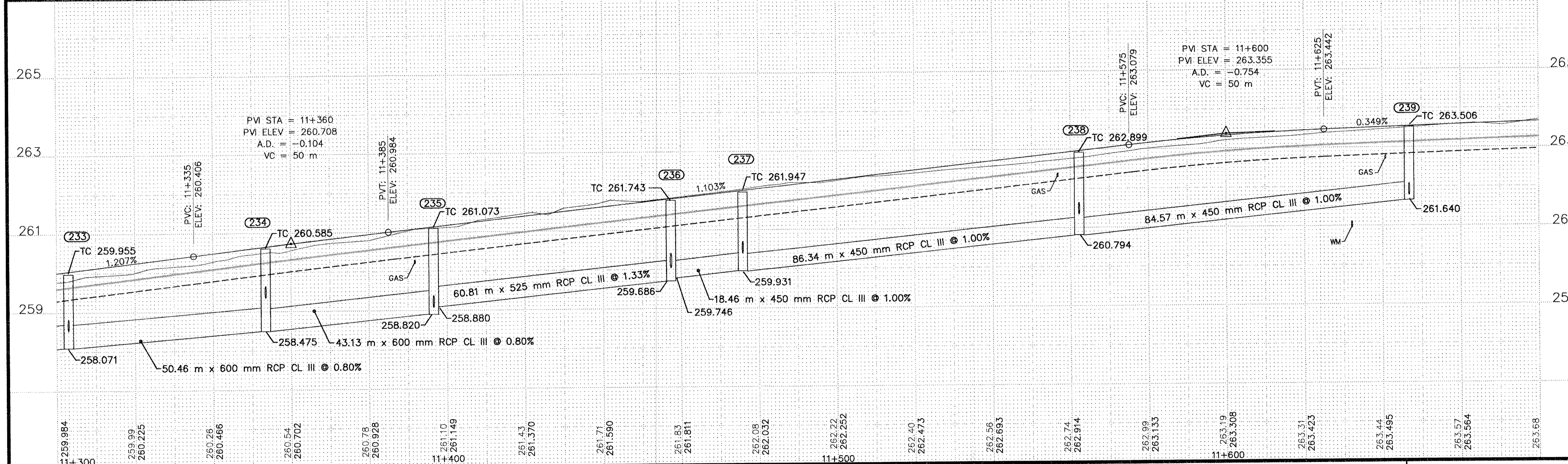
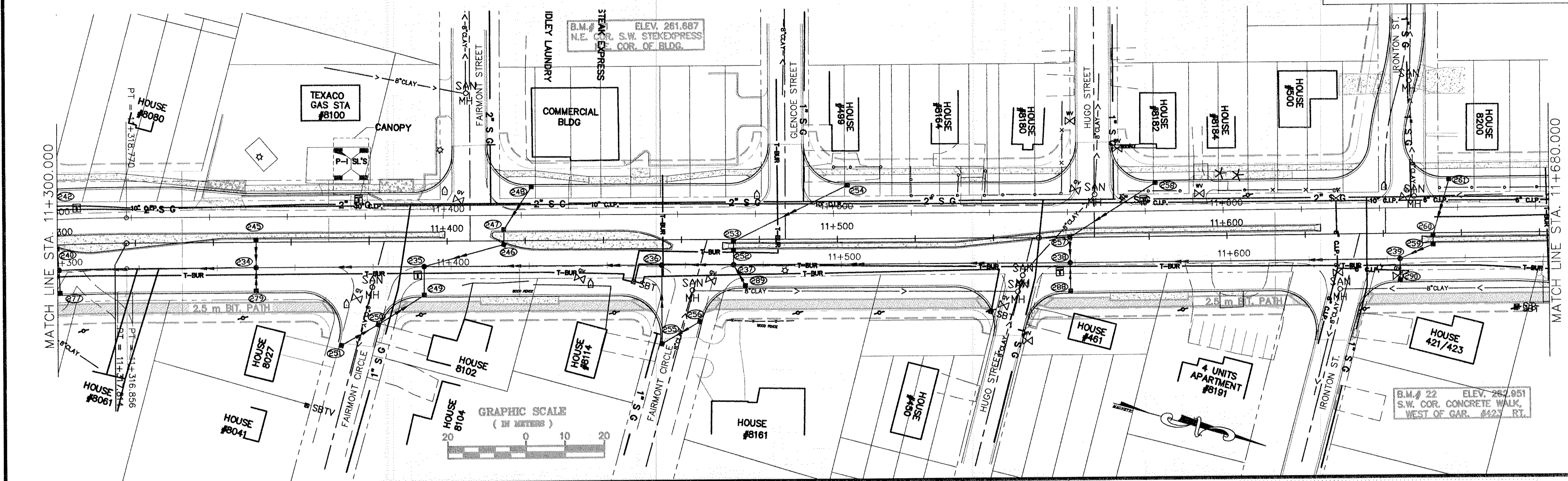

NO	DATE	BY	CKD	APPR	REVISION

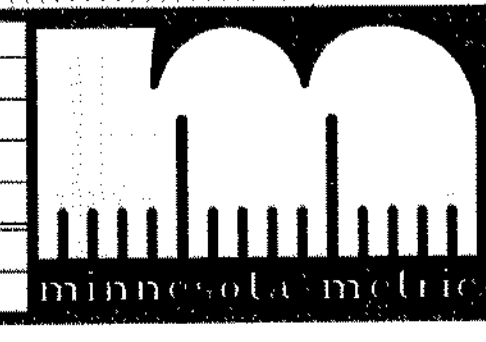

I HEREBY CERTIFY THAT THIS PLAN WAS PREPARED BY ME OR UNDER MY DIRECT SUPERVISION AND THAT I AM A DULY REGISTERED PROFESSIONAL ENGINEER UNDER THE LAWS OF THE STATE OF MINNESOTA.

DATE _____ REG. NO. _____



ANOKA COUNTY
HIGHWAY DEPT.

STATE PROJECT NO. 02-601-37
STATE PROJECT NO. 127-020-20
STATE PROJECT NO. 114-020-18
COUNTY PROJECT NO. _____

DRAINAGE PLAN AND PROFILE
STA. 11+300 TO STA. 11+680
Sheet 33 of 93 Sheets

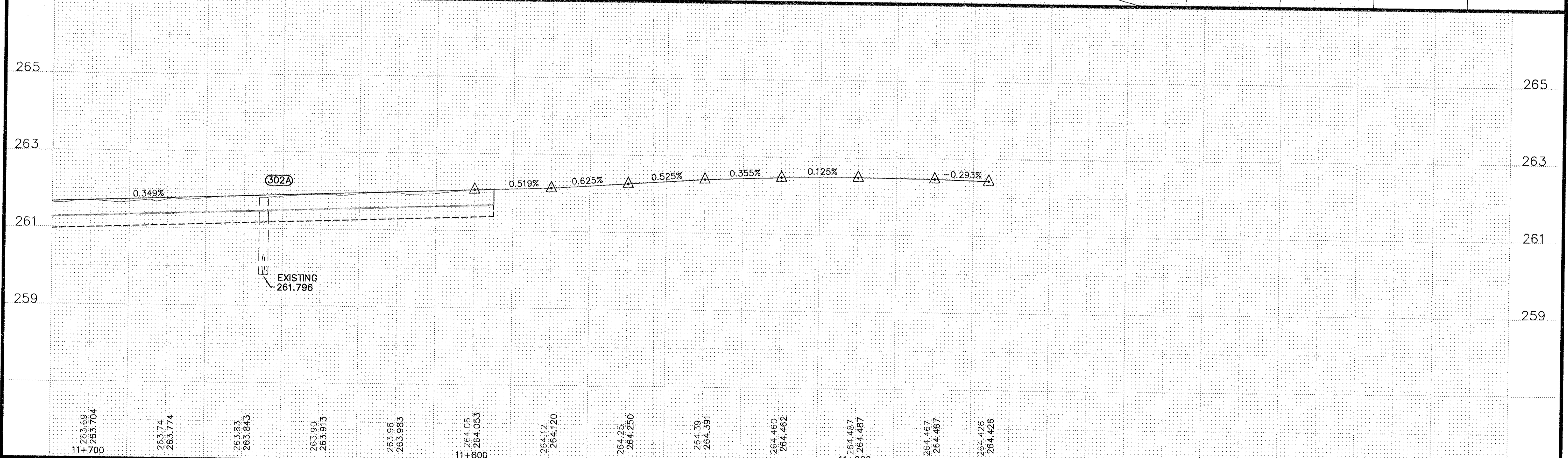
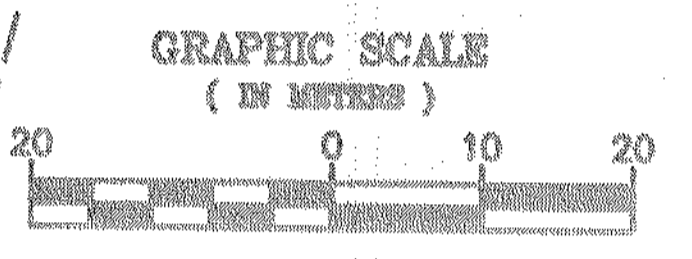
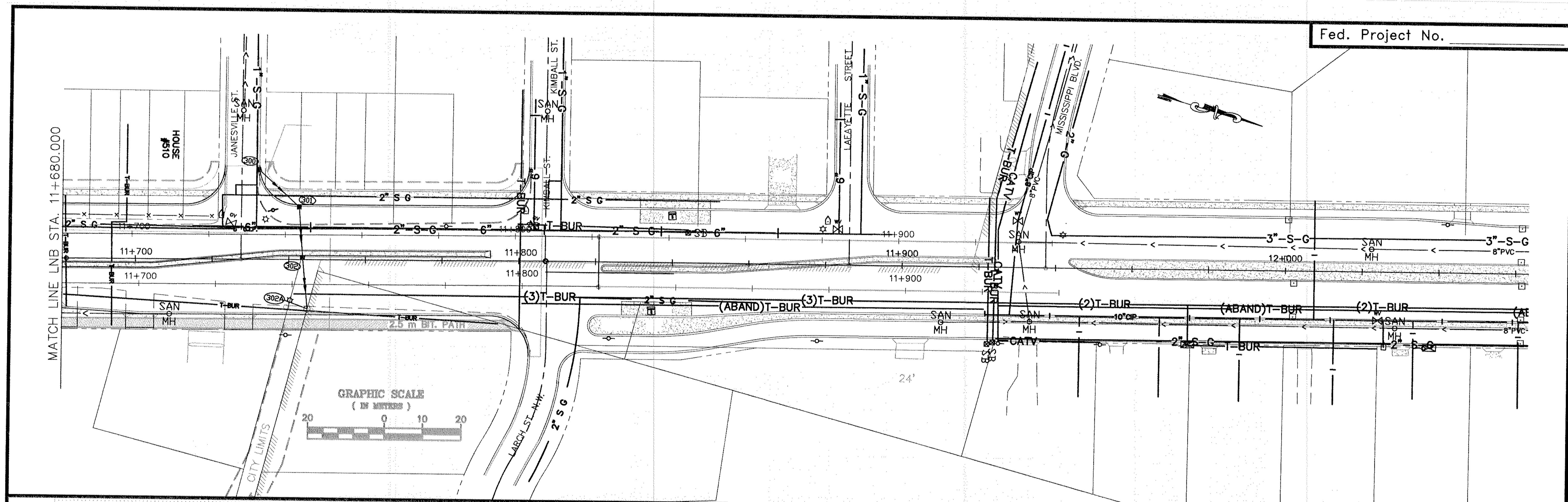

NO	DATE	BY	CKD	APPR	REVISION



I HEREBY CERTIFY THAT THIS PLAN WAS PREPARED BY ME OR UNDER MY DIRECT SUPERVISION AND THAT I AM A DULY REGISTERED PROFESSIONAL ENGINEER UNDER THE LAWS OF THE STATE OF MINNESOTA.

DATE _____ REG. NO. _____



**ANOKA COUNTY
HIGHWAY DEPT.**

STATE PROJECT NO. 02-601-37
 STATE PROJECT NO. 127-020-20
 STATE PROJECT NO. 114-020-18
 COUNTY PROJECT NO. _____

**DRAINAGE PLAN
AND PROFILE**
 STA. 11+680 TO STA. 11+805
 Sheet 34 of 93 Sheets

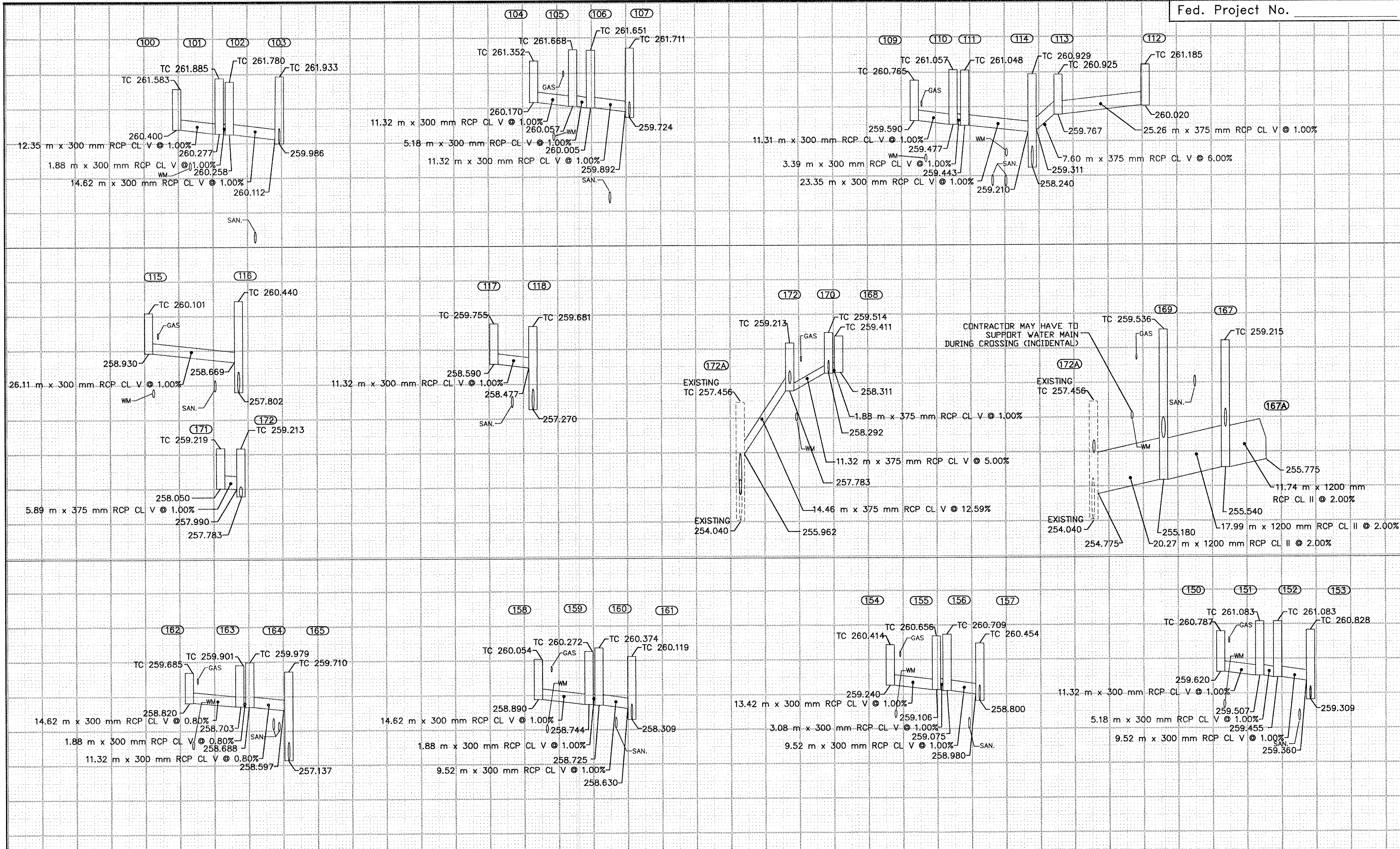

NO	DATE	BY	CKD	APPR	REVISION

NAME: n:\anoka\9708\dwg\30-profilep.dwg

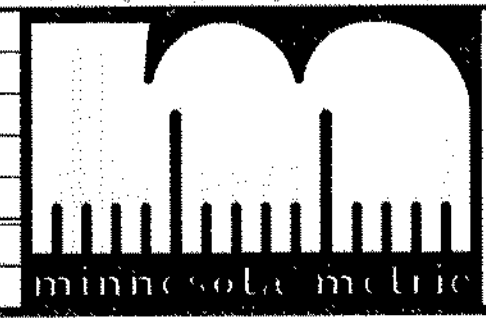

I HEREBY CERTIFY THAT THIS PLAN WAS PREPARED BY ME OR UNDER MY DIRECT SUPERVISION AND THAT I AM A DULY REGISTERED PROFESSIONAL ENGINEER UNDER THE LAWS OF THE STATE OF MINNESOTA.

DATE _____ REG. NO. _____



**ANOKA COUNTY
HIGHWAY DEPT.**

STATE PROJECT NO. 02-601-37
 STATE PROJECT NO. 127-020-20
 STATE PROJECT NO. 114-020-18
 COUNTY PROJECT NO. _____

MISC. STORM PROFILES
 Sheet 35 of 93 Sheets

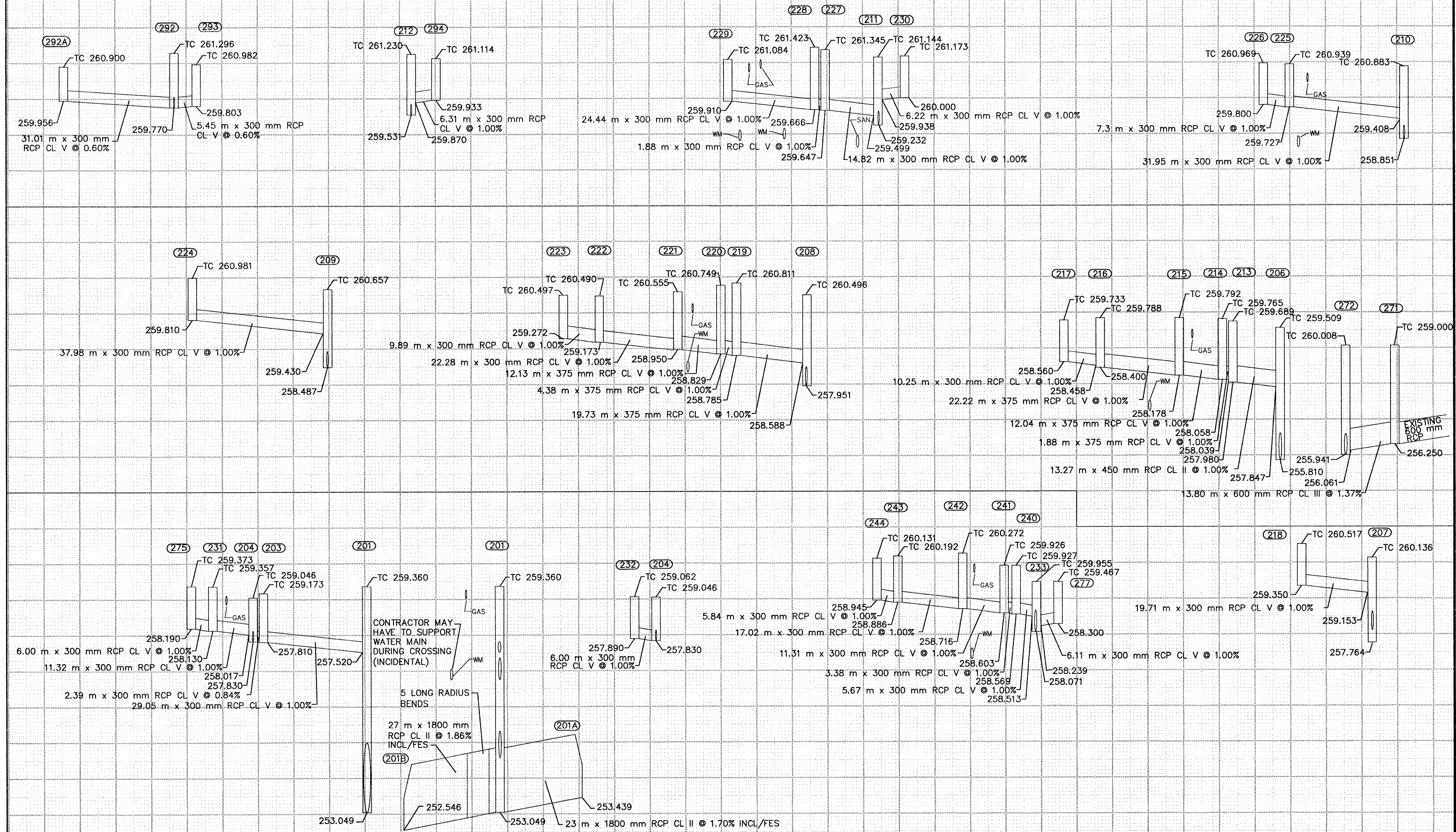

NO	DATE	BY	CKD	APPR	REVISION
NAME: n:\anoka\9708\dwg\31-profile.dwg					



I HEREBY CERTIFY THAT THIS PLAN WAS PREPARED BY ME OR UNDER MY DIRECT SUPERVISION AND THAT I AM A DULY REGISTERED PROFESSIONAL ENGINEER UNDER THE LAWS OF THE STATE OF MINNESOTA.

DATE _____ REG. NO. _____

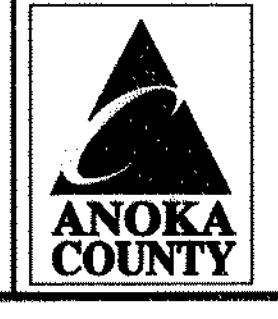

**ANOKA COUNTY
HIGHWAY DEPT.**

STATE PROJECT NO. 02-601-37
 STATE PROJECT NO. 127-020-20
 STATE PROJECT NO. 114-020-18
 COUNTY PROJECT NO. _____

MISC. STORM PROFILES
 Sheet 36 of 93 Sheets

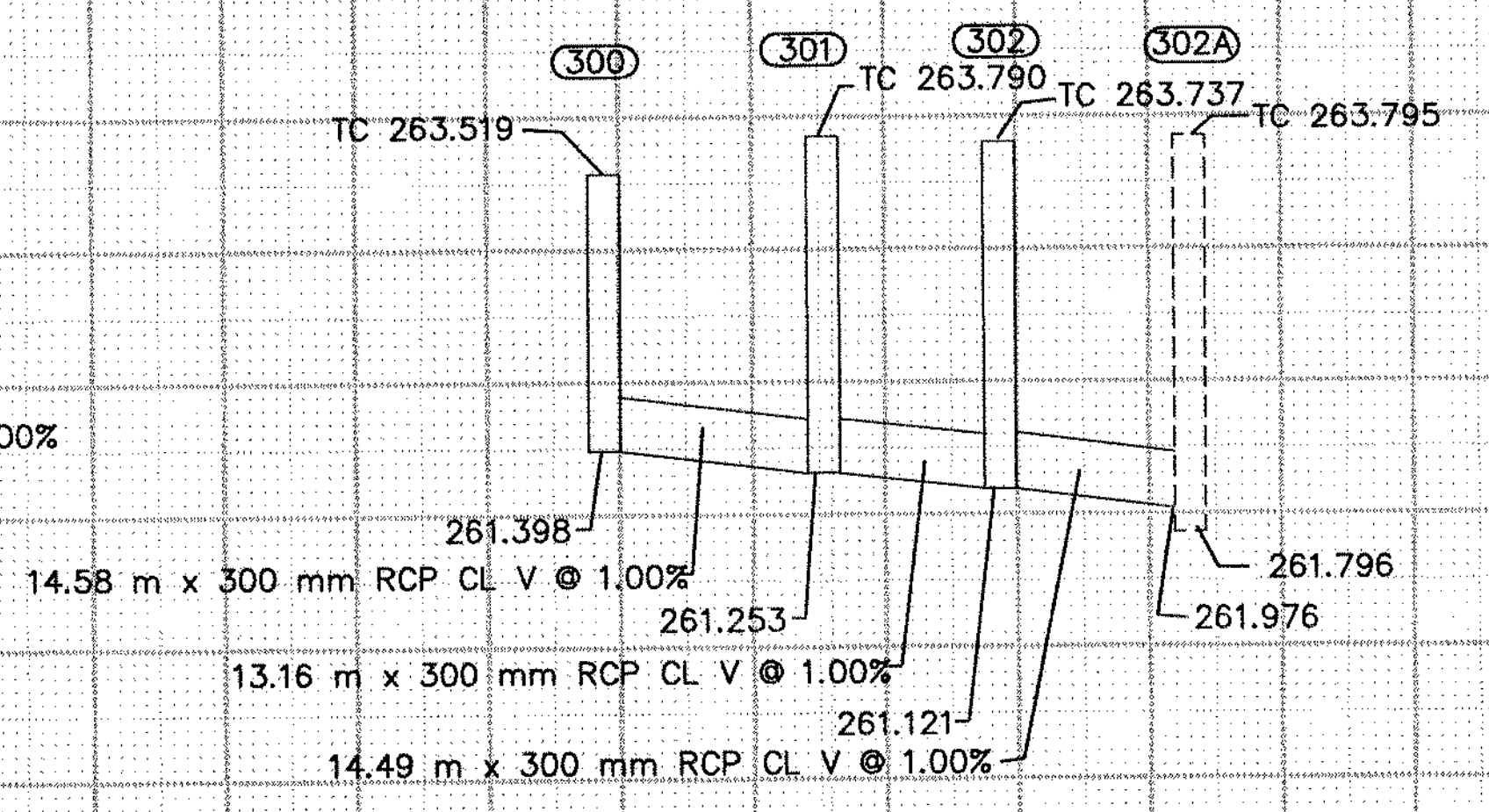
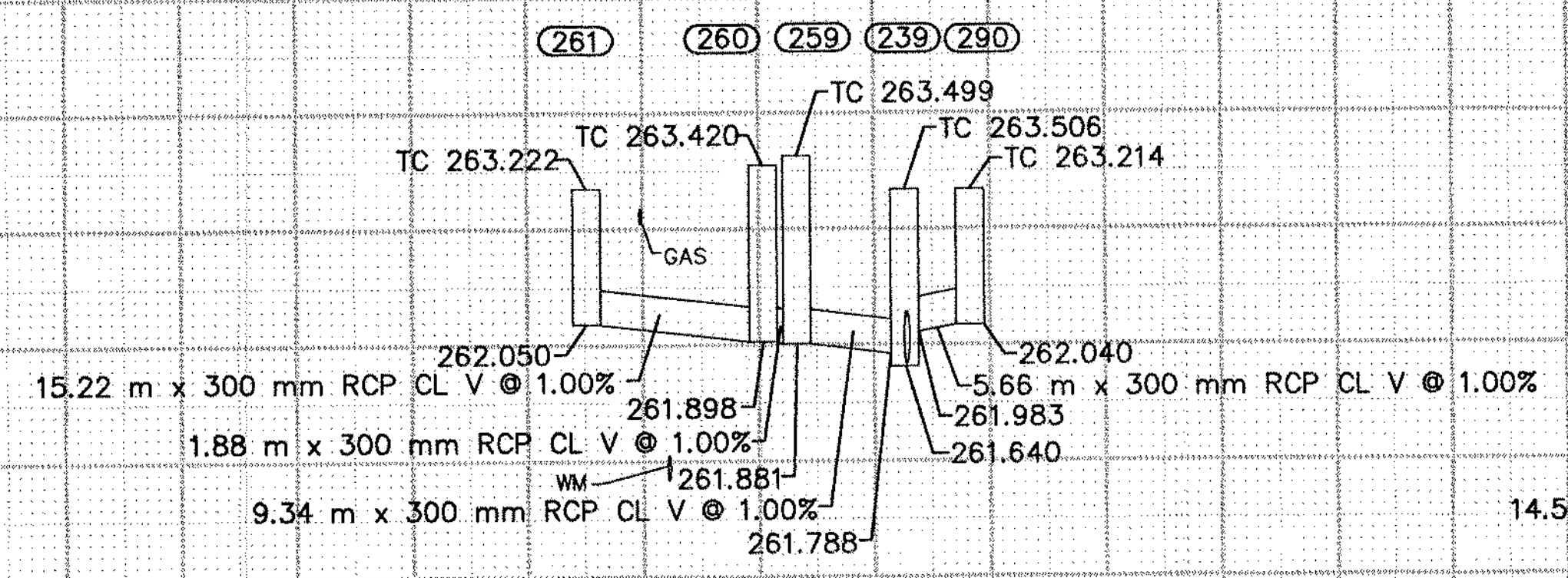
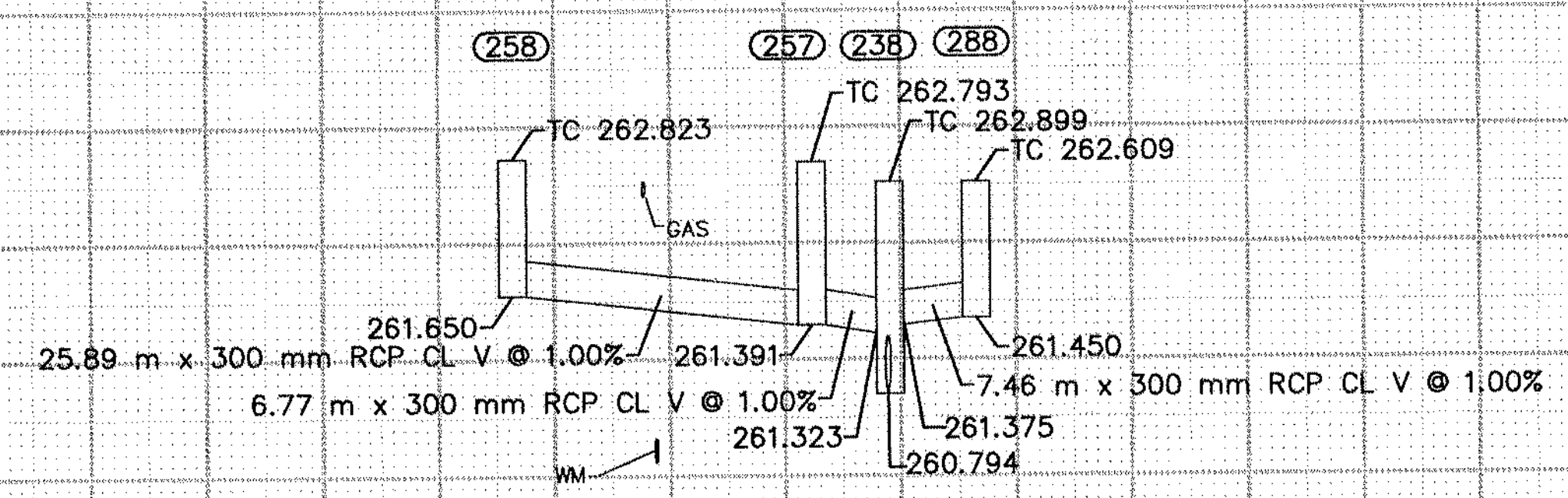
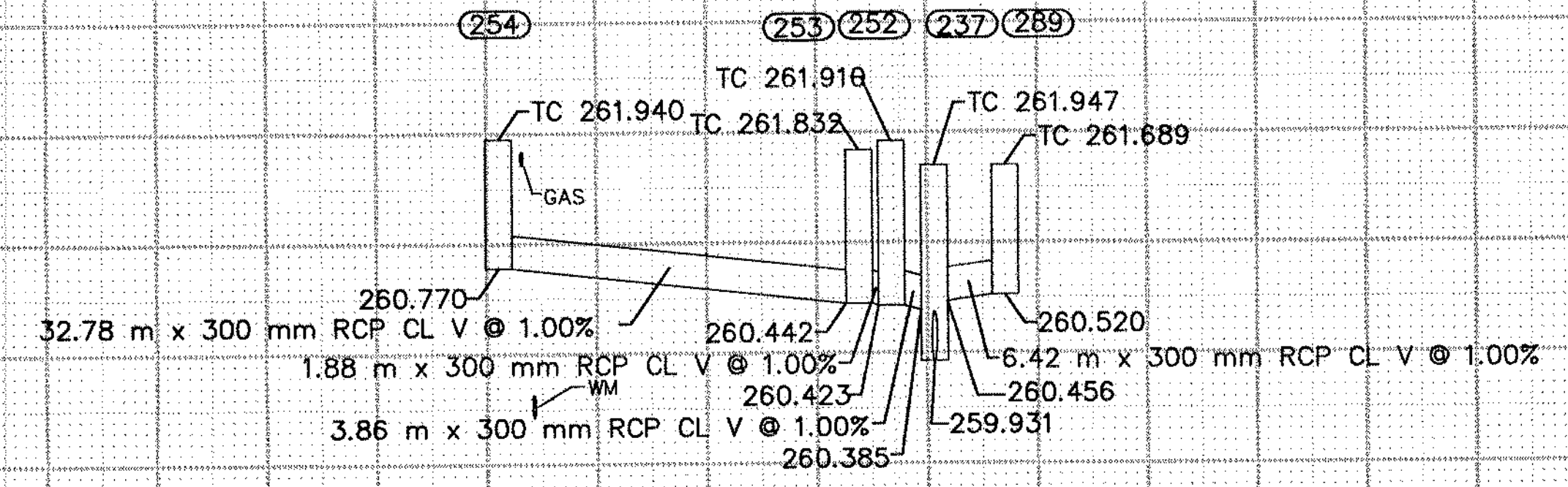
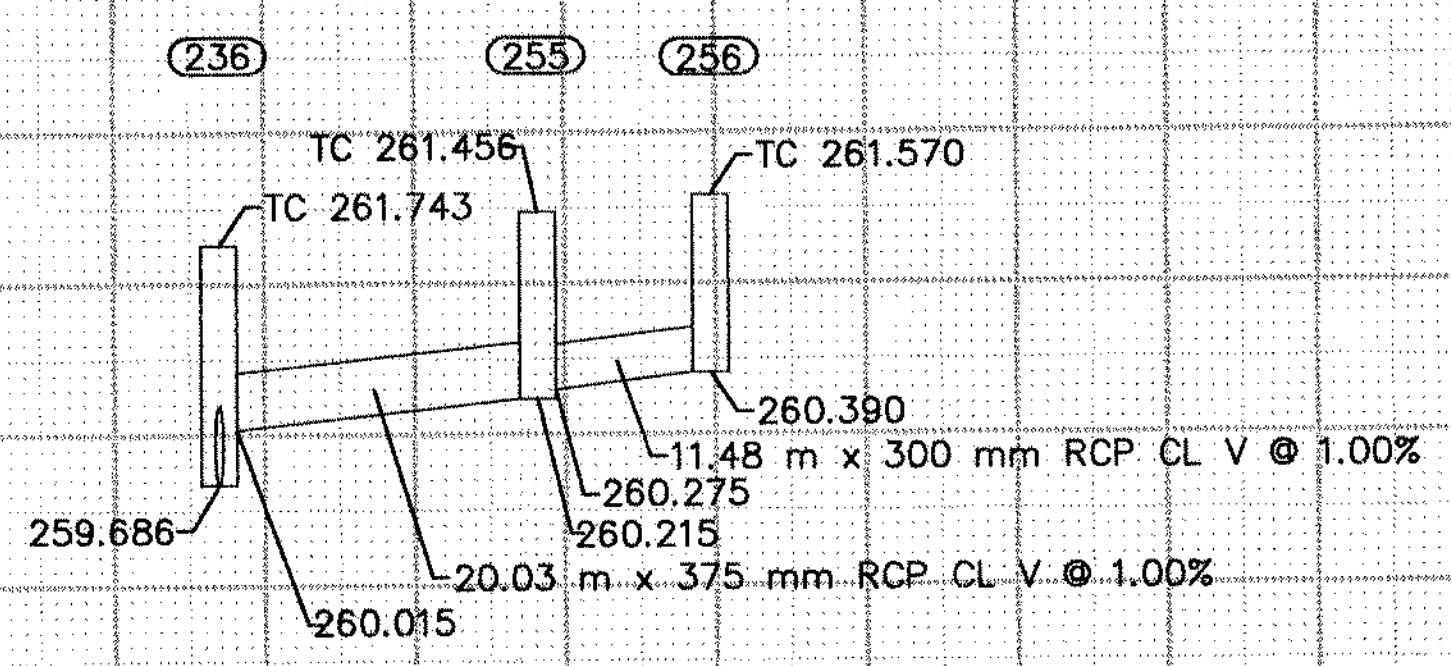
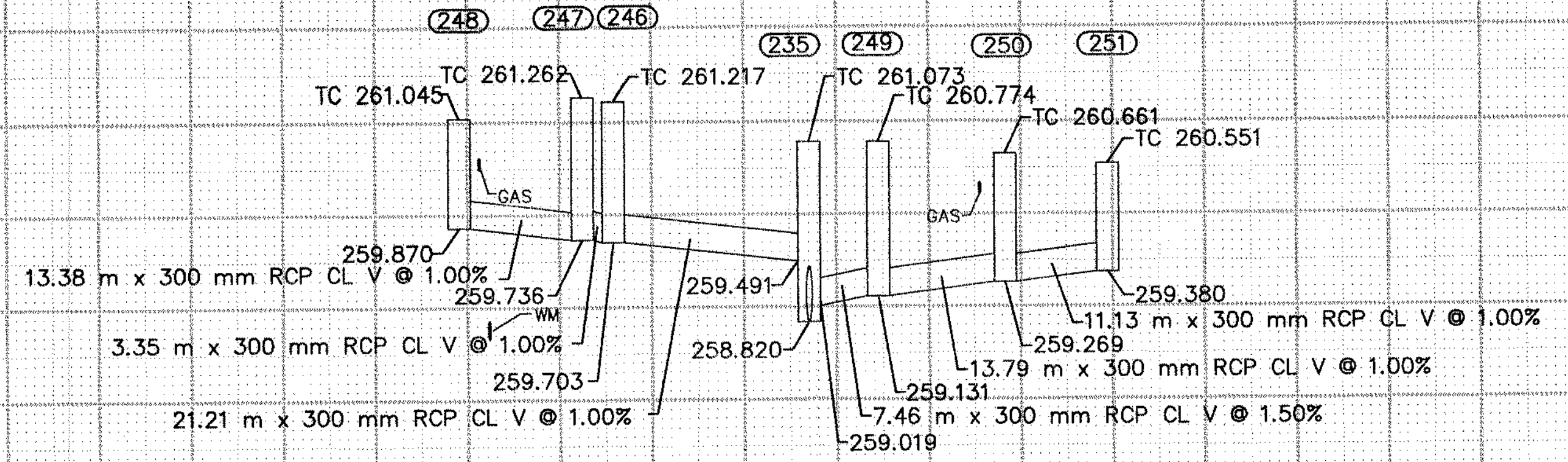
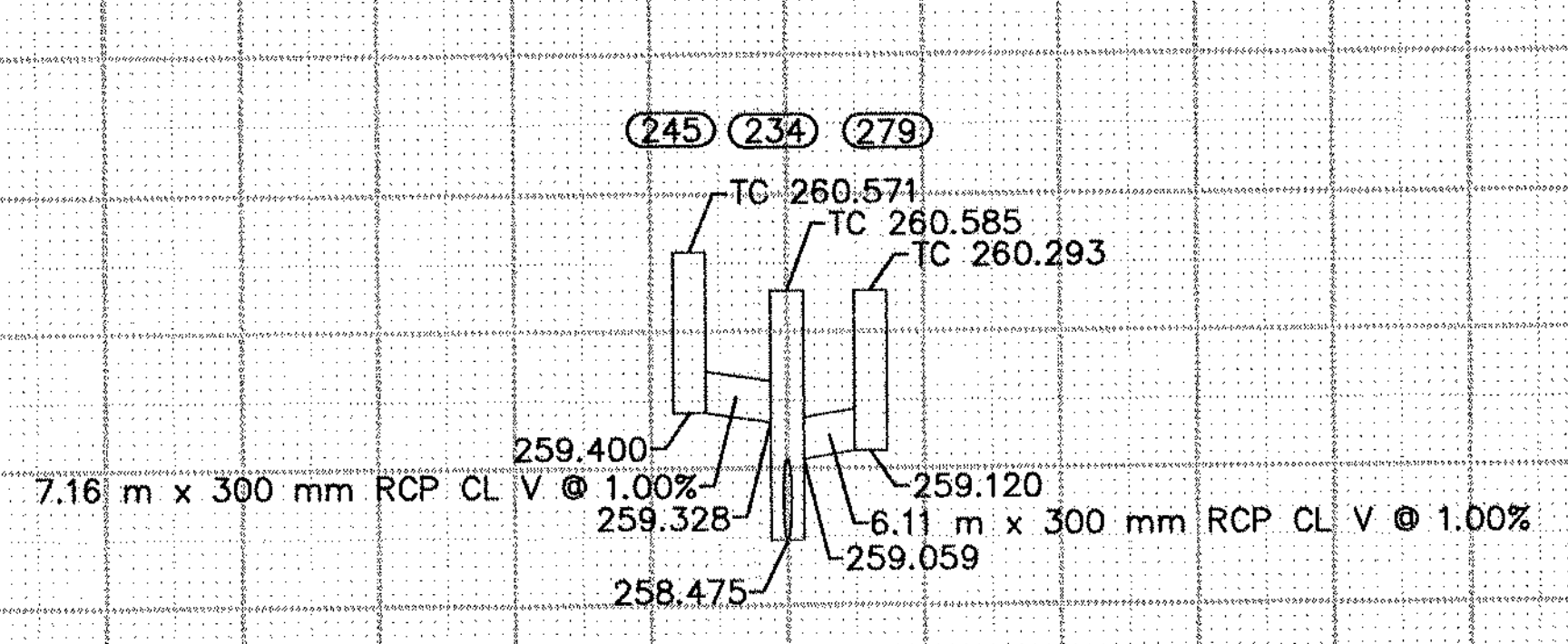

NO	DATE	BY	CKD	APPR	REVISION

NAME: n:\anoka\9708\dwg\32-profilep.dwg

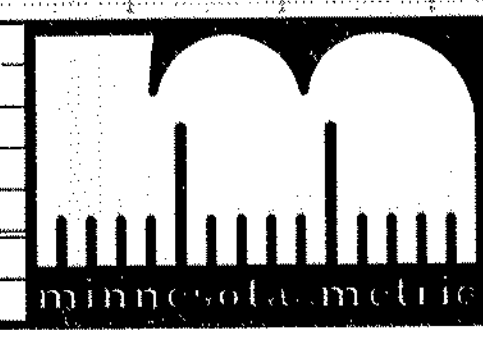

I HEREBY CERTIFY THAT THIS PLAN WAS PREPARED BY ME OR UNDER MY DIRECT SUPERVISION AND THAT I AM A DULY REGISTERED PROFESSIONAL ENGINEER UNDER THE LAWS OF THE STATE OF MINNESOTA.

DATE _____ REG. NO. _____



ANOKA COUNTY
HIGHWAY DEPT.

STATE PROJECT NO. 02-601-37
 STATE PROJECT NO. 127-020-20
 STATE PROJECT NO. 114-020-18
 COUNTY PROJECT NO. _____

MISC. STORM PROFILES

Sheet 37 of 93 Sheets

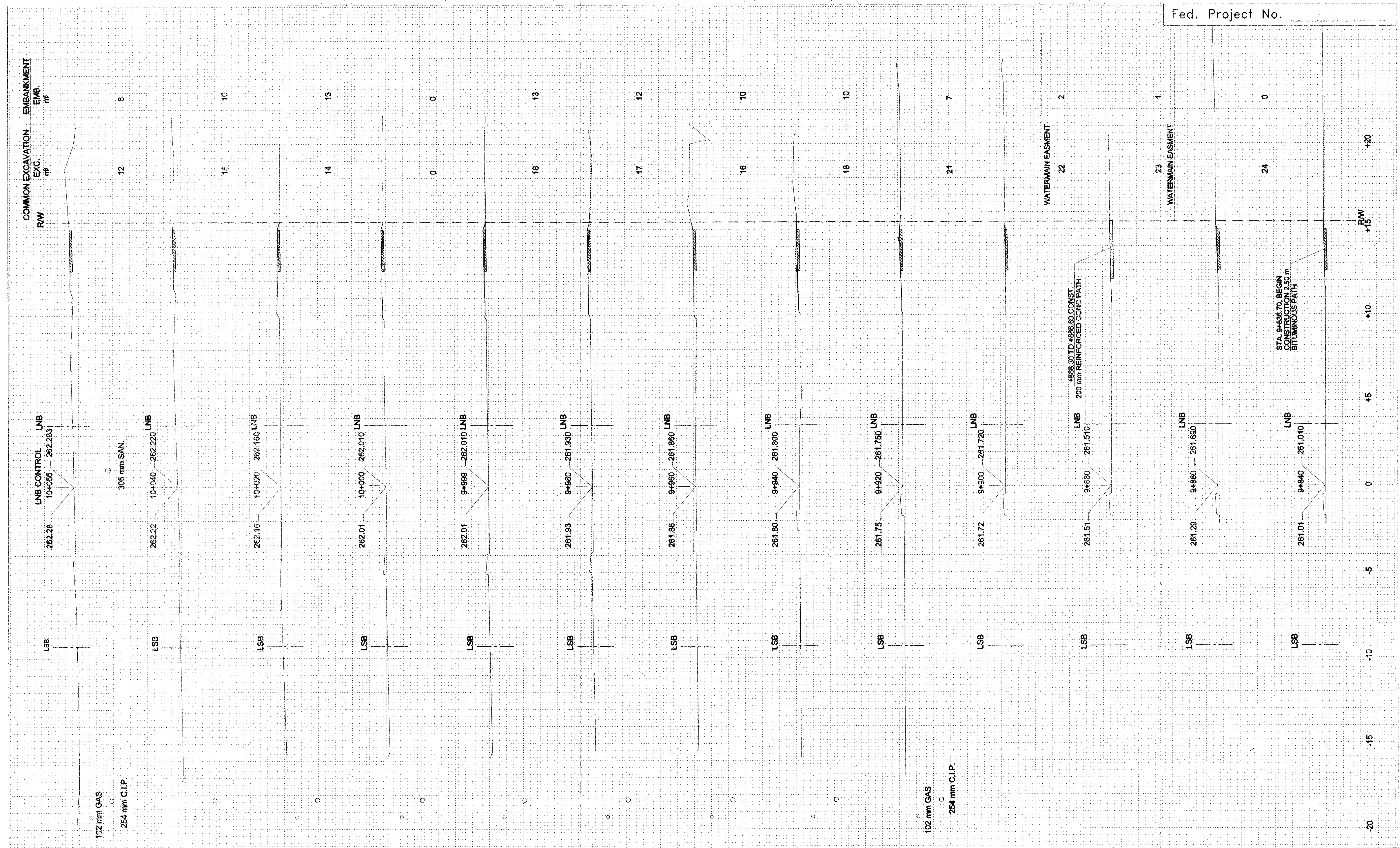

NO.	DATE	BY	CKD	APPR	REVISION

NAME: SECT1.dwg 102898 34732

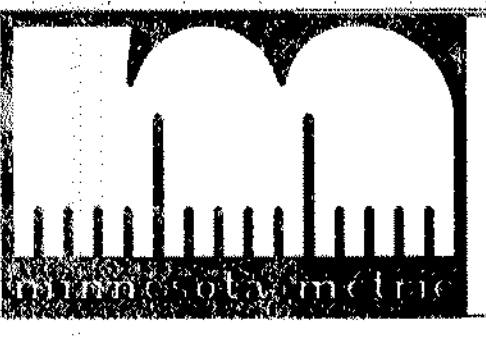

I HEREBY CERTIFY THAT THIS PLAN WAS PREPARED BY ME OR UNDER MY DIRECT SUPERVISION AND THAT I AM A DULY REGISTERED PROFESSIONAL ENGINEER UNDER THE LAWS OF THE STATE OF MINNESOTA.

DATE _____ REG. NO. _____

DRAWN BY _____ DATE _____
 DESIGN BY _____ DATE _____
 CHECKED BY _____ DATE _____



ANOKA COUNTY
HIGHWAY DEPT.

STATE PROJECT NO. 02-601-37
 STATE PROJECT NO. 127-020-20
 STATE PROJECT NO. 114-020-18
 COUNTY PROJECT NO. _____

CROSS-SECTION
 STA 9+840.00 TO 10+055.00
 Sheet 38 of 93 Sheets

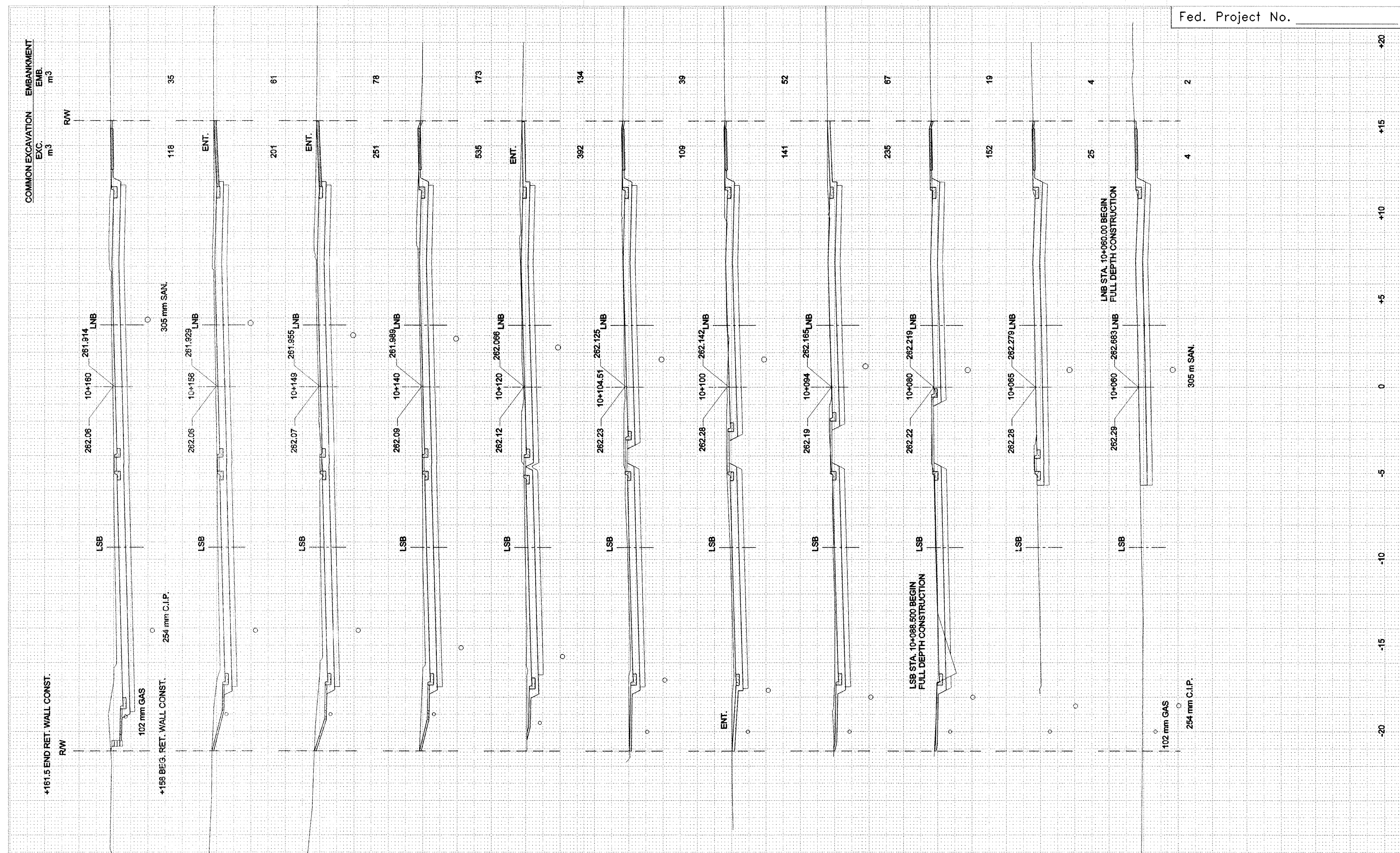

NO	DATE	BY	CKD	APPR	REVISION
NAME: SECT2.dwg	11390	23903			

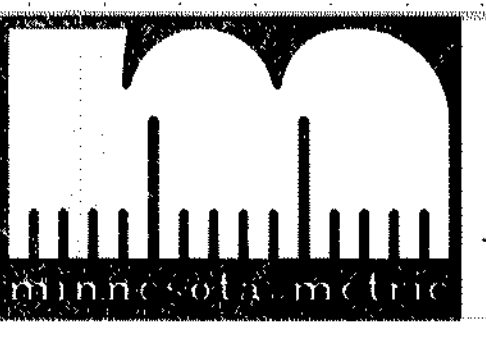

I HEREBY CERTIFY THAT THIS PLAN WAS PREPARED BY ME OR UNDER MY DIRECT SUPERVISION AND THAT I AM A DULY REGISTERED PROFESSIONAL ENGINEER UNDER THE LAWS OF THE STATE OF MINNESOTA.

DATE _____ REG. NO. _____

DRAWN BY _____ DATE _____
 DESIGN BY _____ DATE _____
 CHECKED BY _____ DATE _____

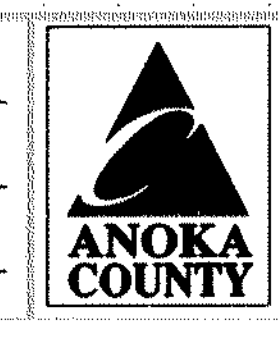

**ANOKA COUNTY
 HIGHWAY DEPT.**

STATE PROJECT NO. 02-601-37
 STATE PROJECT NO. 127-020-20
 STATE PROJECT NO. 114-020-18
 COUNTY PROJECT NO. _____

CROSS- SECTION
 STA 10+060.000 TO 10+160.000
 Sheet 39 of 93 Sheets

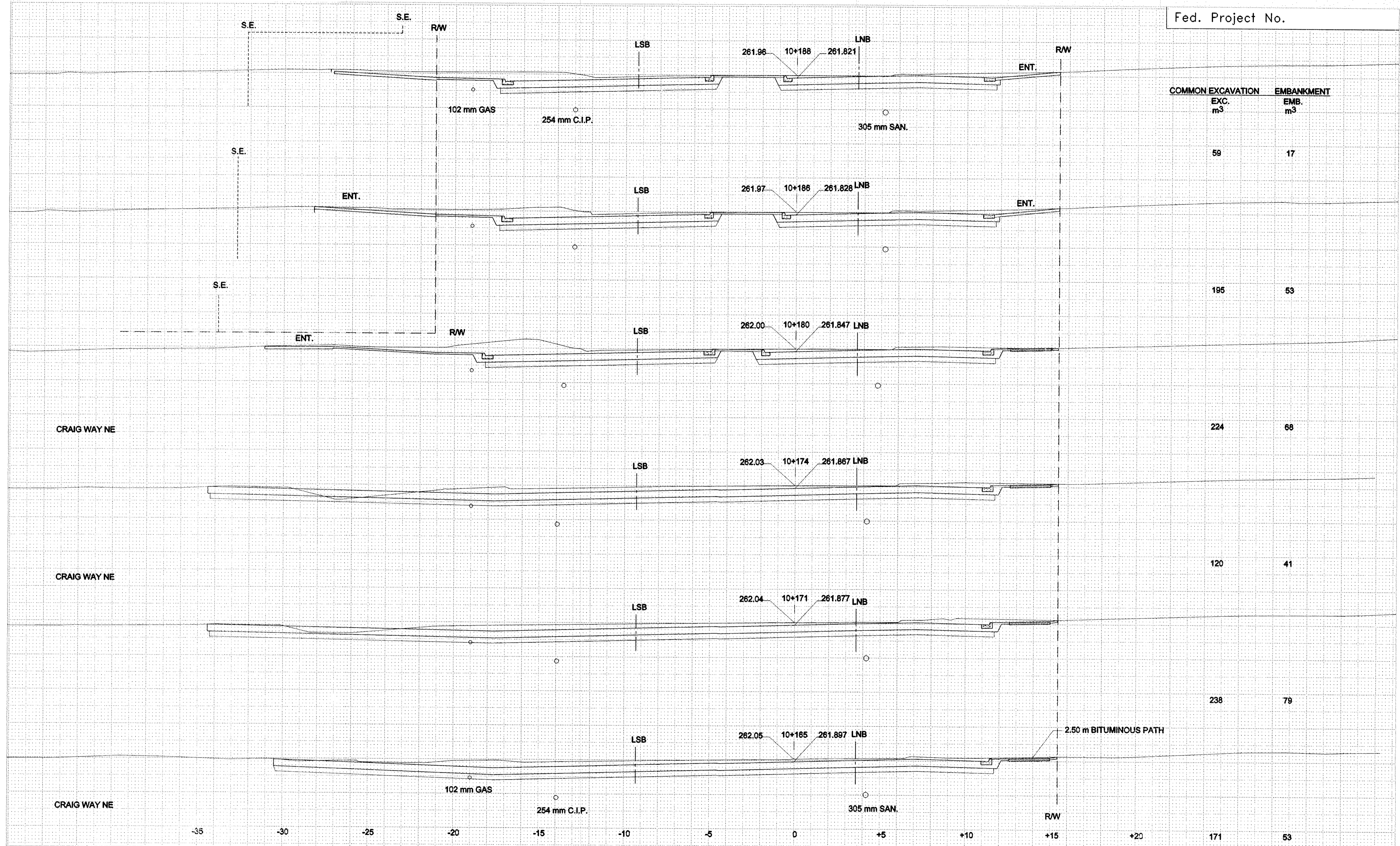

COMMON EXCAVATION	EMBANKMENT
EXC. m ³	EMB. m ³

59	17
----	----

195	53
-----	----

224	68
-----	----

120	41
-----	----

238	79
-----	----

171	53
-----	----

NO	DATE	BY	CKD	APPR	REVISION
NAME	SECT3.dwg	11-3-98	3:21:07	pm	EST

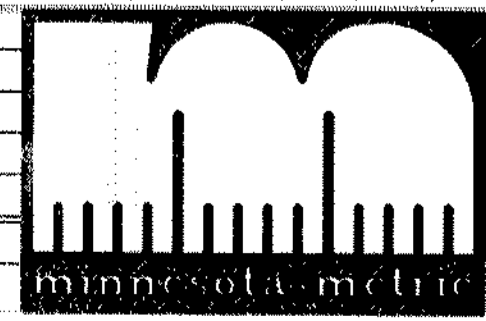

I HEREBY CERTIFY THAT THIS PLAN WAS PREPARED BY ME OR UNDER MY DIRECT SUPERVISION AND THAT I AM A DULY REGISTERED PROFESSIONAL ENGINEER UNDER THE LAWS OF THE STATE OF MINNESOTA.

DATE _____ REG. NO. _____

DRAWN BY _____ DATE _____
 DESIGN BY _____ DATE _____
 CHECKED BY _____ DATE _____



**ANOKA COUNTY
HIGHWAY DEPT.**

STATE PROJECT NO. 02-601-37
 STATE PROJECT NO. 127-020-20
 STATE PROJECT NO. 114-020-18
 COUNTY PROJECT NO. _____

CROSS- SECTION
 STA 10+165.000 TO 10+188.00
 Sheet 40 of 93 Sheets

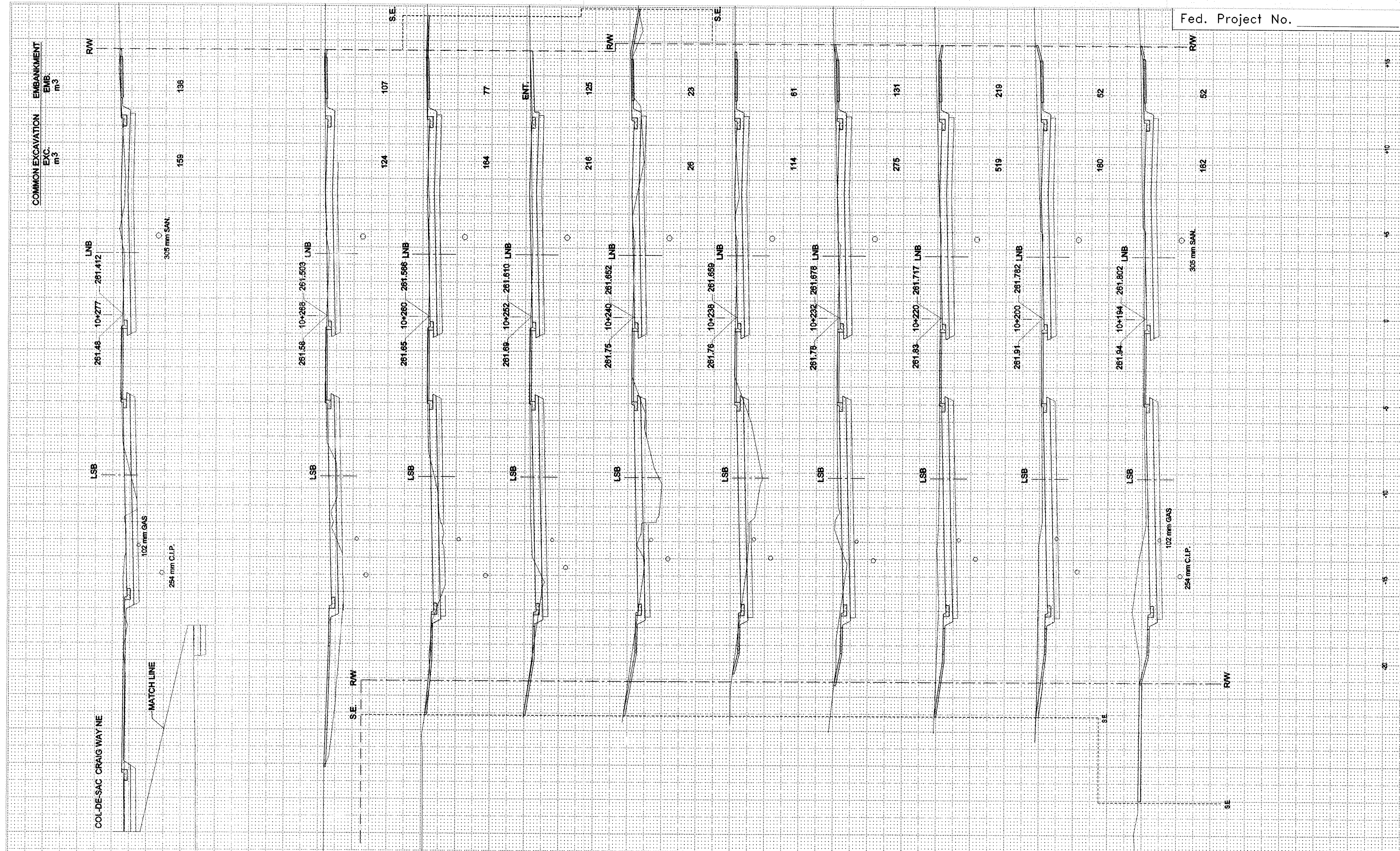

NO	DATE	BY	CKD	APPR	REVISION
NAME: SECT4.dwg	3499	114026			

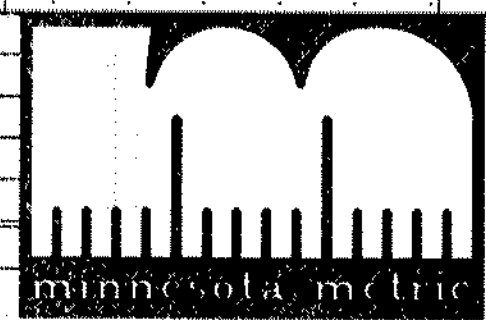

I HEREBY CERTIFY THAT THIS PLAN WAS PREPARED BY ME OR UNDER MY DIRECT SUPERVISION AND THAT I AM A DULY REGISTERED PROFESSIONAL ENGINEER UNDER THE LAWS OF THE STATE OF MINNESOTA.

DATE _____ REG. NO. _____

DRAWN BY _____ MN DATE 03/01/99
 DESIGN BY _____ KGJ DATE 03/01/99
 CHECKED BY _____ LR DATE 03/01/99

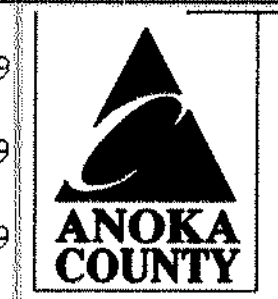

ANOKA COUNTY
 HIGHWAY DEPT.

STATE PROJECT NO. _____ 02-601-37
 STATE PROJECT NO. _____ 127-020-20
 STATE PROJECT NO. _____ 114-020-18
 COUNTY PROJECT NO. _____

CROSS- SECTION
 STA 10+194.000 TO 10+277.000
 Sheet 41 of 93 Sheets

COMMON EXCAVATION EXC. m³
EMBANKMENT EMB. m³

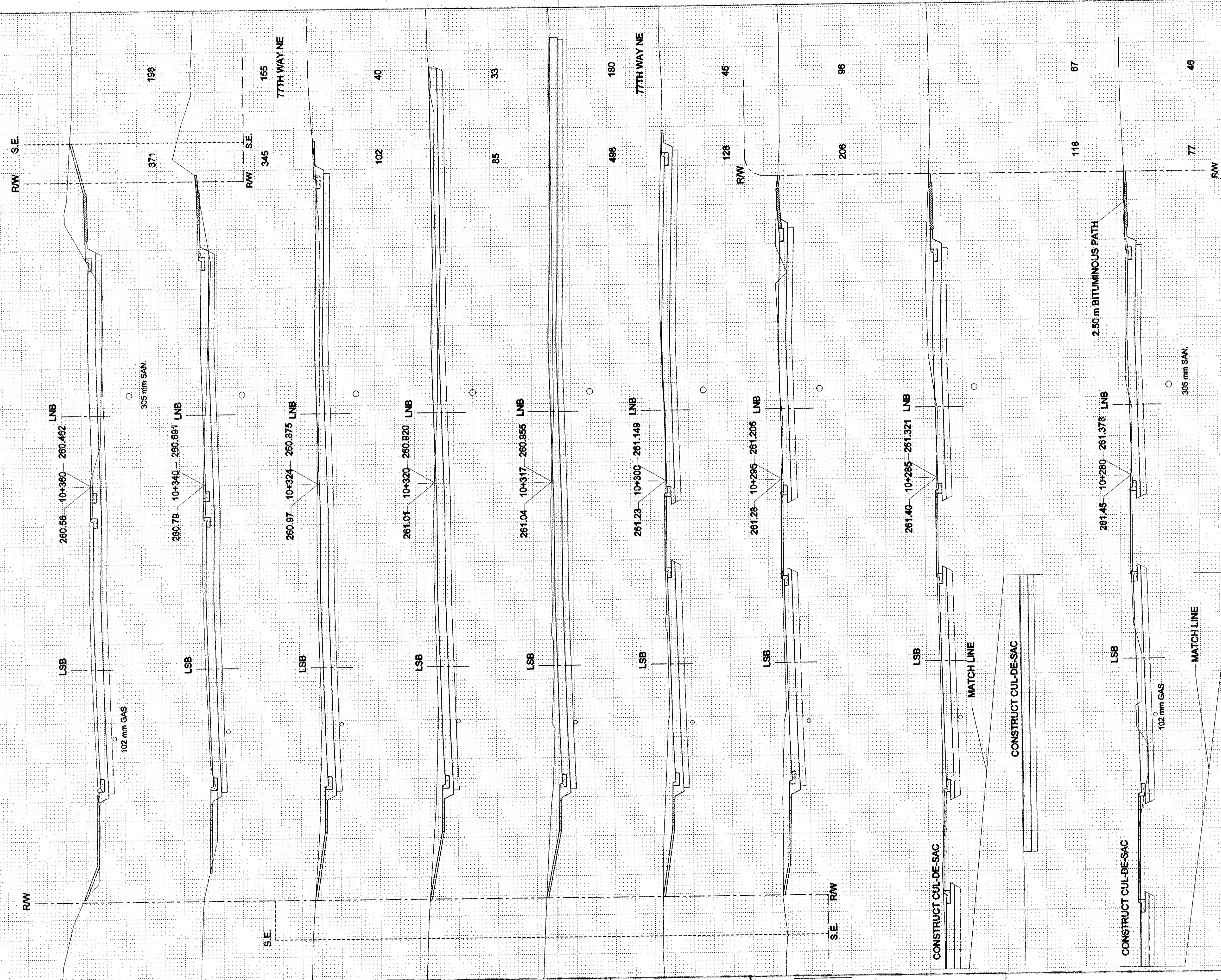

NO	DATE	BY	CKD	APPR	REVISION

NAME: SECT5.dwg 11-5-98 3:40:38 pm EST

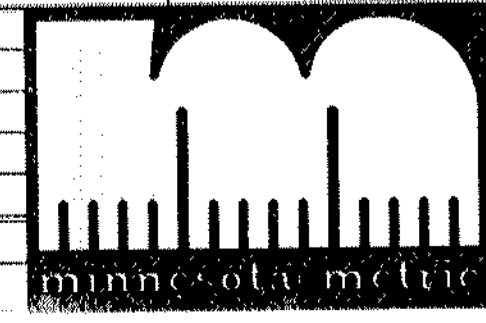

I HEREBY CERTIFY THAT THIS PLAN WAS PREPARED BY ME OR UNDER MY DIRECT SUPERVISION AND THAT I AM A DULY REGISTERED PROFESSIONAL ENGINEER UNDER THE LAWS OF THE STATE OF MINNESOTA.

DATE _____ REG. NO. _____

DRAWN BY _____ DATE _____
 DESIGN BY _____ DATE _____
 CHECKED BY _____ DATE _____



ANOKA COUNTY HIGHWAY DEPT.

STATE PROJECT NO. 02-601-37
 STATE PROJECT NO. 127-020-20
 STATE PROJECT NO. 114-020-18
 COUNTY PROJECT NO. _____

CROSS- SECTION
 STA 10+280.000 TO 10+360.000
 Sheet 42 of 93 Sheets

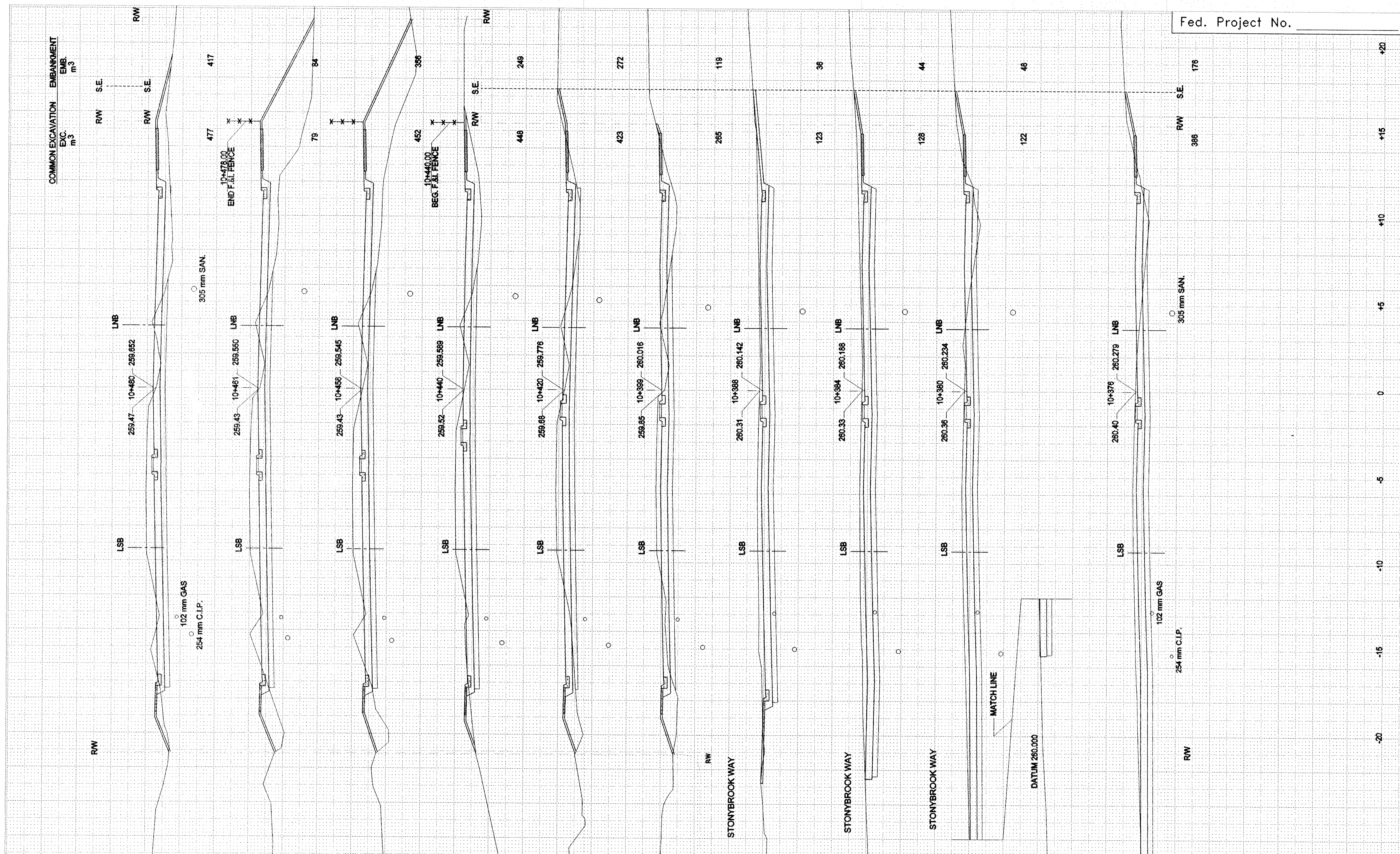

NO	DATE	BY	CKD	APPR	REVISION

NAME: SECT6.dwg 11498 124344



I HEREBY CERTIFY THAT THIS PLAN WAS PREPARED BY ME OR UNDER MY DIRECT SUPERVISION AND THAT I AM A DULY REGISTERED PROFESSIONAL ENGINEER UNDER THE LAWS OF THE STATE OF MINNESOTA.

DATE _____ REG. NO. _____

DRAWN BY _____ DATE _____
 DESIGN BY _____ DATE _____
 CHECKED BY _____ DATE _____



ANOKA COUNTY
HIGHWAY DEPT.

STATE PROJECT NO. 02-601-37
 STATE PROJECT NO. 127-020-20
 STATE PROJECT NO. 114-020-18
 COUNTY PROJECT NO. _____

CROSS- SECTION
 STA 10+376.000 TO 10+480.000
 Sheet 43 of 93 Sheets

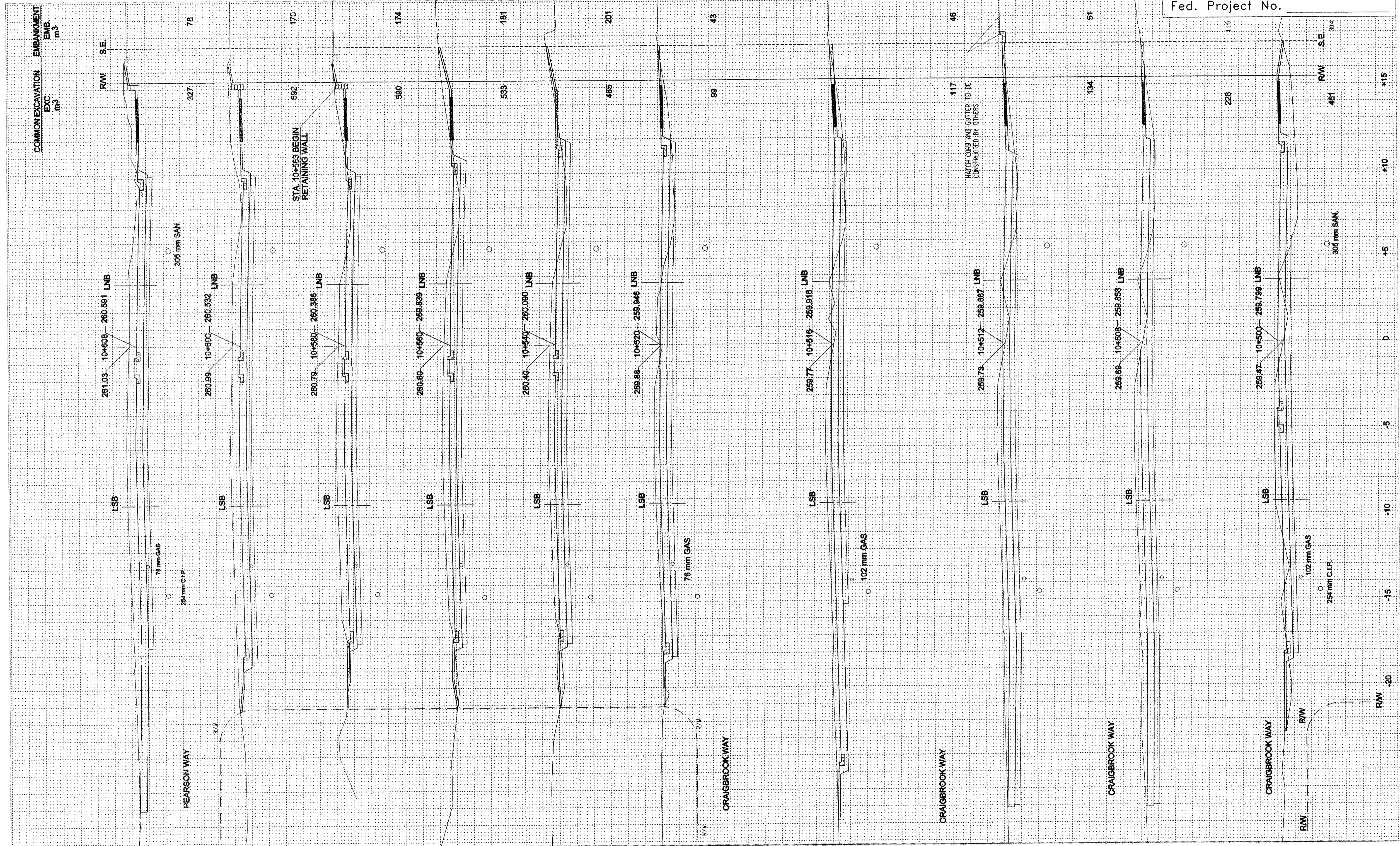

NO.	DATE	BY	CHKD	APPR	REVISION
1	12-28-98	LBC			
2	10-55-10				am EST

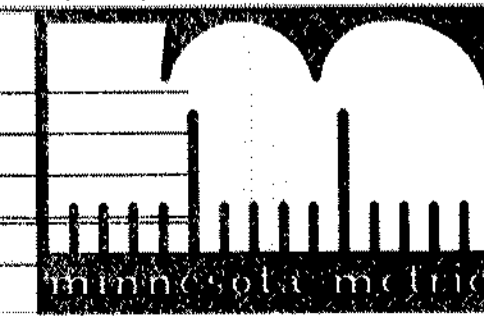

BY ME OR UNDER MY DIRECT SUPERVISION AND THAT I AM A DULY REGISTERED PROFESSIONAL ENGINEER UNDER THE LAWS OF THE STATE OF MINNESOTA.

DATE _____ REG. NO. _____

DRAWN BY: PGL DATE: 9/10/98
 DESIGN BY: KGJ DATE: 12/28/98
 CHECKED BY: LR DATE: 12/28/98

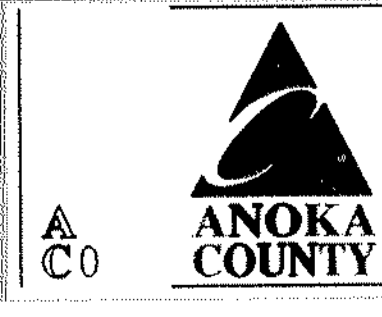

ANOKA COUNTY HIGHWAY DEPT.

STATE PROJECT NO. 02-601-37
 STATE PROJECT NO. 127-020-20
 STATE PROJECT NO. 114-020-18
 COUNTY PROJECT NO. _____

CROSS-SECTION
 STA 10+500.000 TO 10+608.000
 Sheet 44 of 93 Sheets

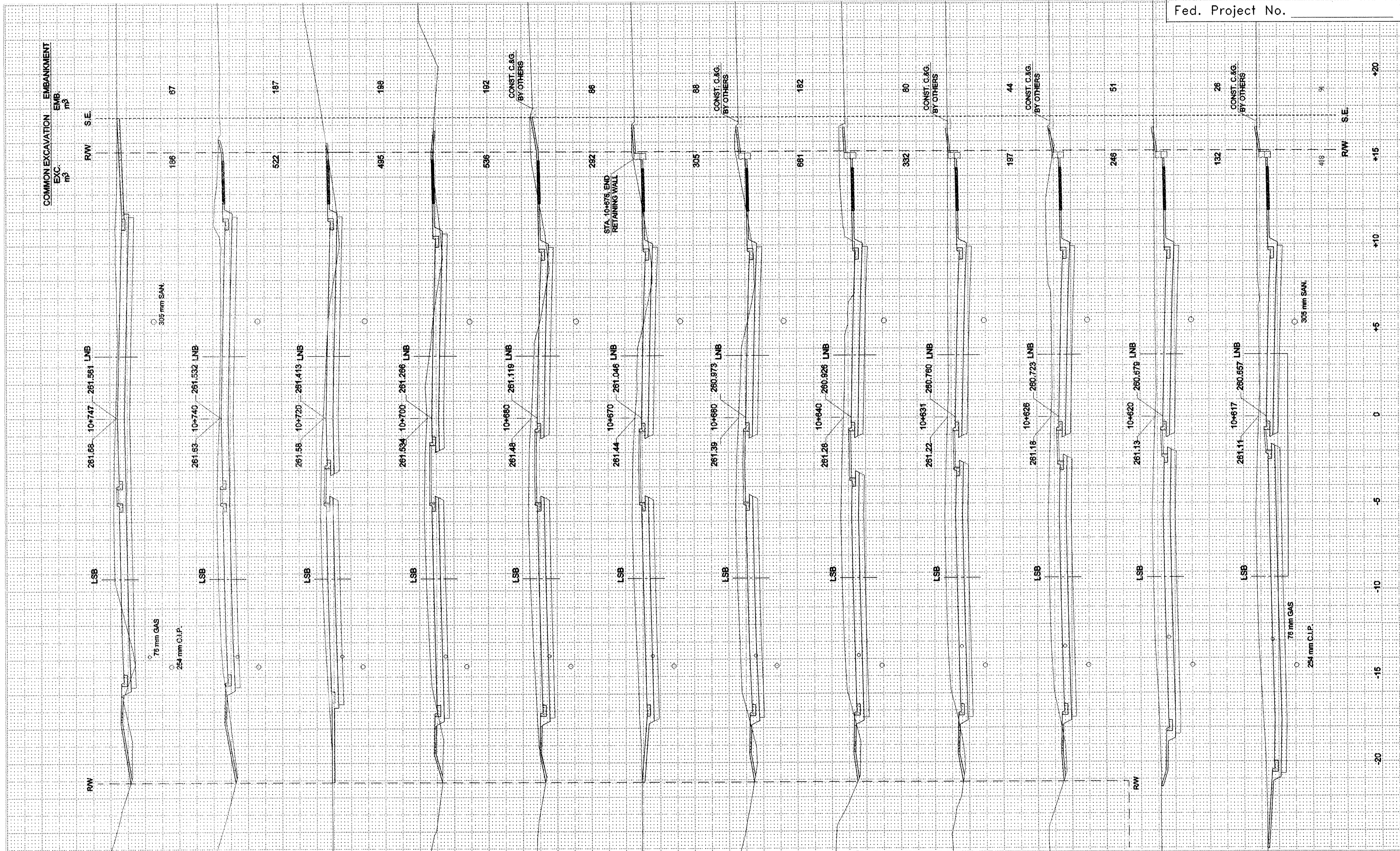

NO	DATE	BY	CKD	APPR	REVISION
NAME	SECT8.dwg	12-22-98	6:02:04	pm	EST



BY ME OR UNDER MY DIRECT SUPERVISION AND THAT I AM A DULY REGISTERED PROFESSIONAL ENGINEER UNDER THE LAWS OF THE STATE OF MINNESOTA.

DATE _____ REG. NO. _____

DRAWN BY MN DATE 12/22/98
 DESIGN BY KGJ DATE 12/22/98
 CHECKED BY LR DATE 12/22/98



**ANOKA COUNTY
HIGHWAY DEPT.**

STATE PROJECT NO. 02-601-37
 STATE PROJECT NO. 127-020-20
 STATE PROJECT NO. 114-020-18
 COUNTY PROJECT NO. _____

CROSS-SECTION
 STA 10+617.000 TO 10+747.000
 Sheet 45 of 93 Sheets

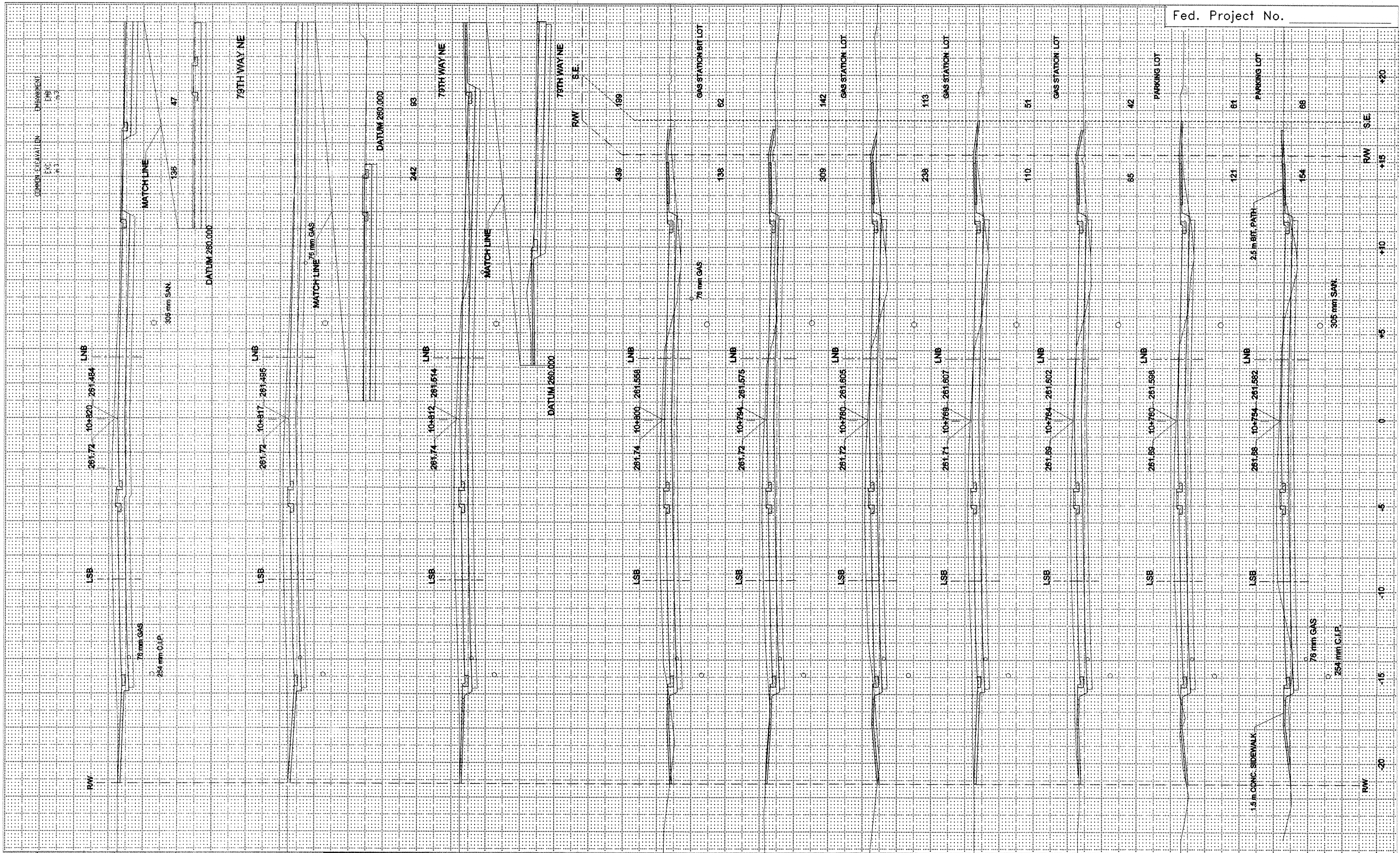

NO	DATE	BY	CKD	APPR	REVISION

NAME: SECT9.dwg 3-1-99 4:04:29 pm EST

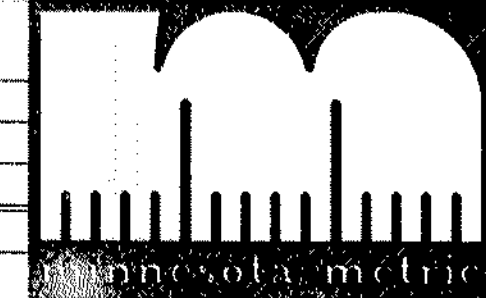

BY ME OR UNDER MY DIRECT SUPERVISION AND THAT I AM A DULY REGISTERED PROFESSIONAL ENGINEER UNDER THE LAWS OF THE STATE OF MINNESOTA.

DATE _____ REG. NO. _____

DRAWN BY: KGJ DATE 03/01/99
 DESIGN BY: KGJ DATE 03/01/99
 CHECKED BY: LR DATE 03/01/99

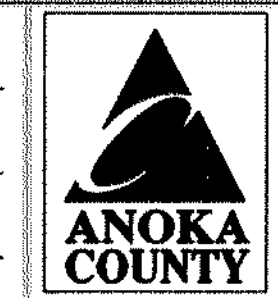

ANOKA COUNTY
 HIGHWAY DEPT.

STATE PROJECT NO. 02-601-37
 STATE PROJECT NO. 127-020-20
 STATE PROJECT NO. 114-020-18
 COUNTY PROJECT NO. _____

CROSS-SECTION
 STA 10+754.000 TO 10+820.000
 Sheet 46 of 93 Sheets

COMMON EXCAVATION	EMBANKMENT
EXC. n.3	EMB. n.3
EDGE OF MAT + SERVICE RD. (TYP)	

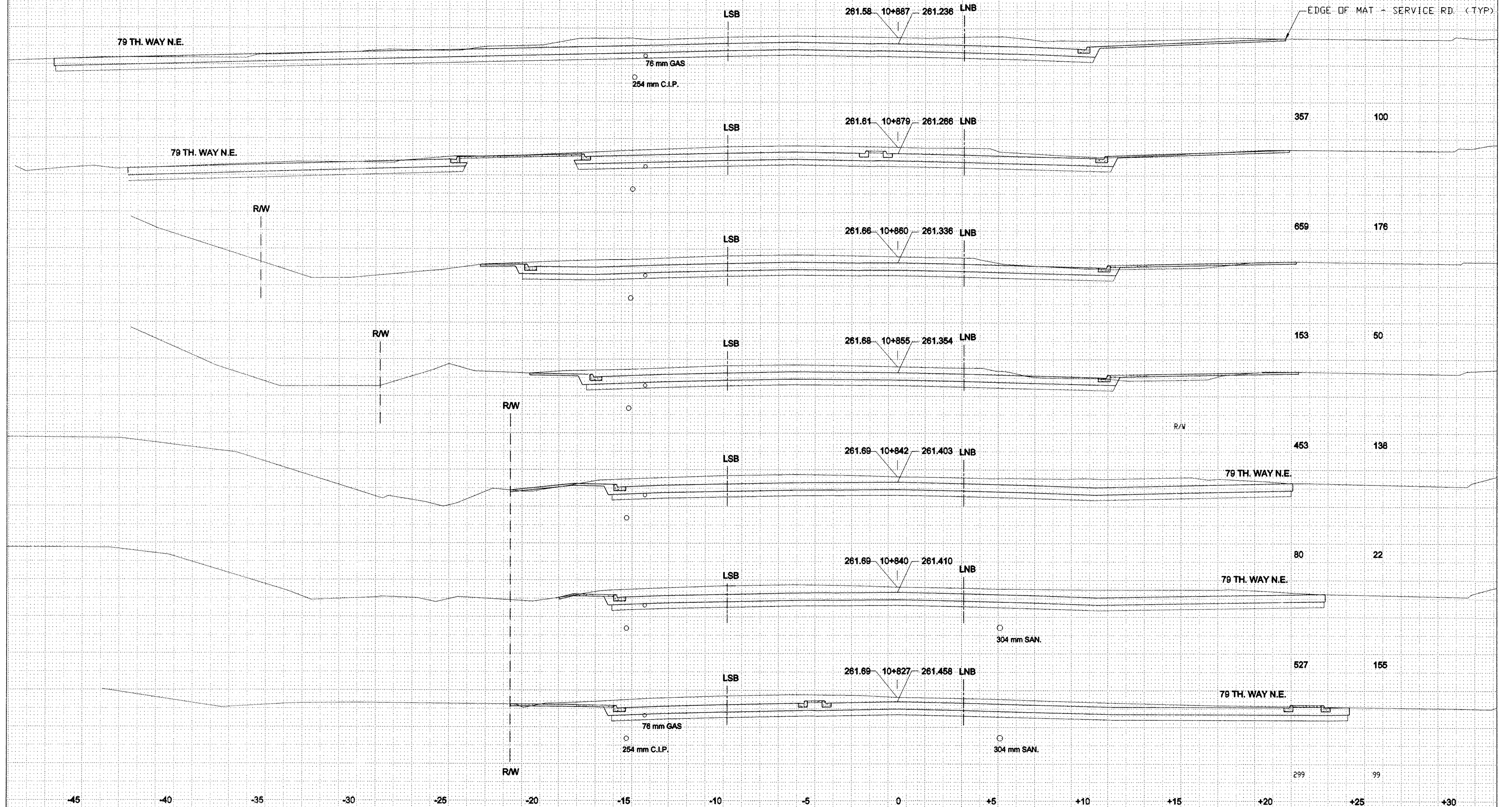

NO	DATE	BY	CKD	APPR	REVISION

NAME: SECT10.dwg 11-4-98 2:45:48 pm EST

I HEREBY CERTIFY THAT THIS PLAN WAS PREPARED BY ME OR UNDER MY DIRECT SUPERVISION AND THAT I AM A DULY REGISTERED PROFESSIONAL ENGINEER UNDER THE LAWS OF THE STATE OF MINNESOTA.

DATE _____ REG. NO. _____

DRAWN BY _____ DATE _____
 DESIGN BY _____ DATE _____
 CHECKED BY _____ DATE _____

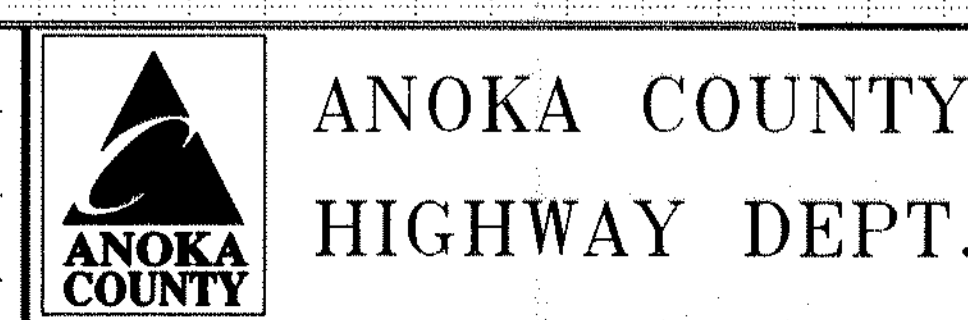

STATE PROJECT NO. 02-601-37
 STATE PROJECT NO. 127-020-20
 STATE PROJECT NO. 114-020-18
 COUNTY PROJECT NO. _____

CROSS-SECTION
 STA 10+827.000 TO 10+887.000
 Sheet 47 of 93 Sheets

COMMON EXCAVATION
EXC.
m³

EMBANKMENT
EMB.
m³

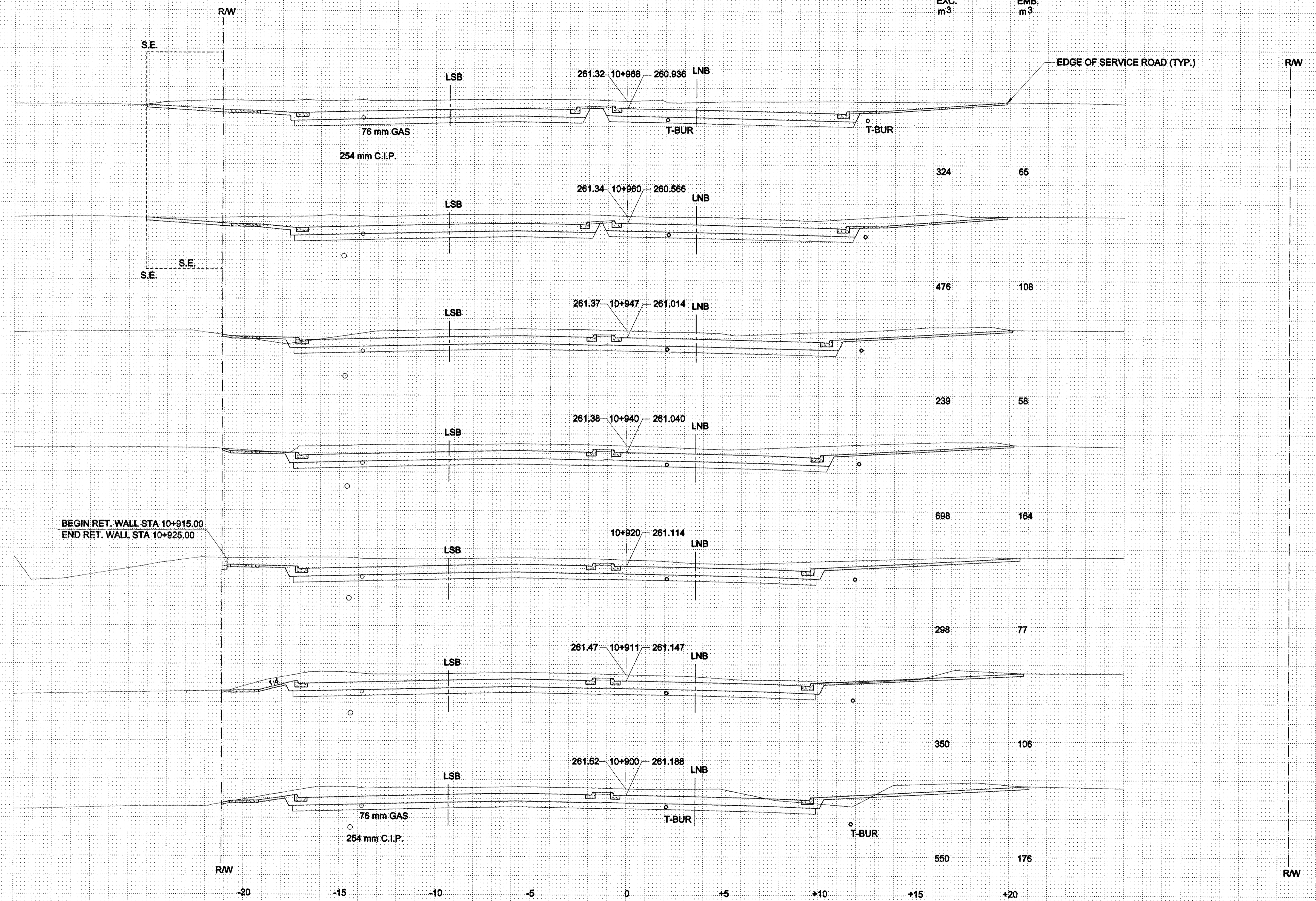

BEGIN RET. WALL STA 10+915.00
END RET. WALL STA 10+925.00

NO	DATE	BY	CKD	APPR	REVISION

NAME: SECT11.dwg 8-17-98 5:04:08 pm EST

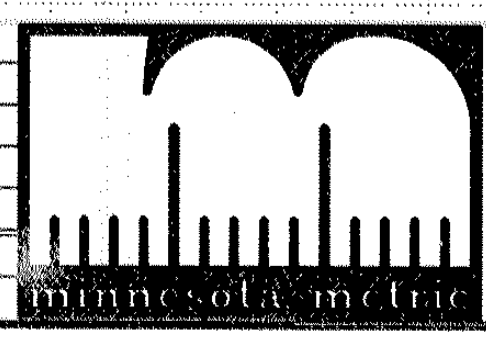

I HEREBY CERTIFY THAT THIS PLAN WAS PREPARED BY ME OR UNDER MY DIRECT SUPERVISION AND THAT I AM A DULY REGISTERED PROFESSIONAL ENGINEER UNDER THE LAWS OF THE STATE OF MINNESOTA.

DATE _____ REG. NO. _____

DRAWN BY _____ DATE _____
DESIGN BY _____ DATE _____
CHECKED BY _____ DATE _____



ANOKA COUNTY
HIGHWAY DEPT.

STATE PROJECT NO. 02-601-37
STATE PROJECT NO. 127-020-20
STATE PROJECT NO. 114-020-18
COUNTY PROJECT NO. _____

CROSS- SECTION
STA 10+900.000 TO 10+968.000
Sheet 48 of 93 Sheets

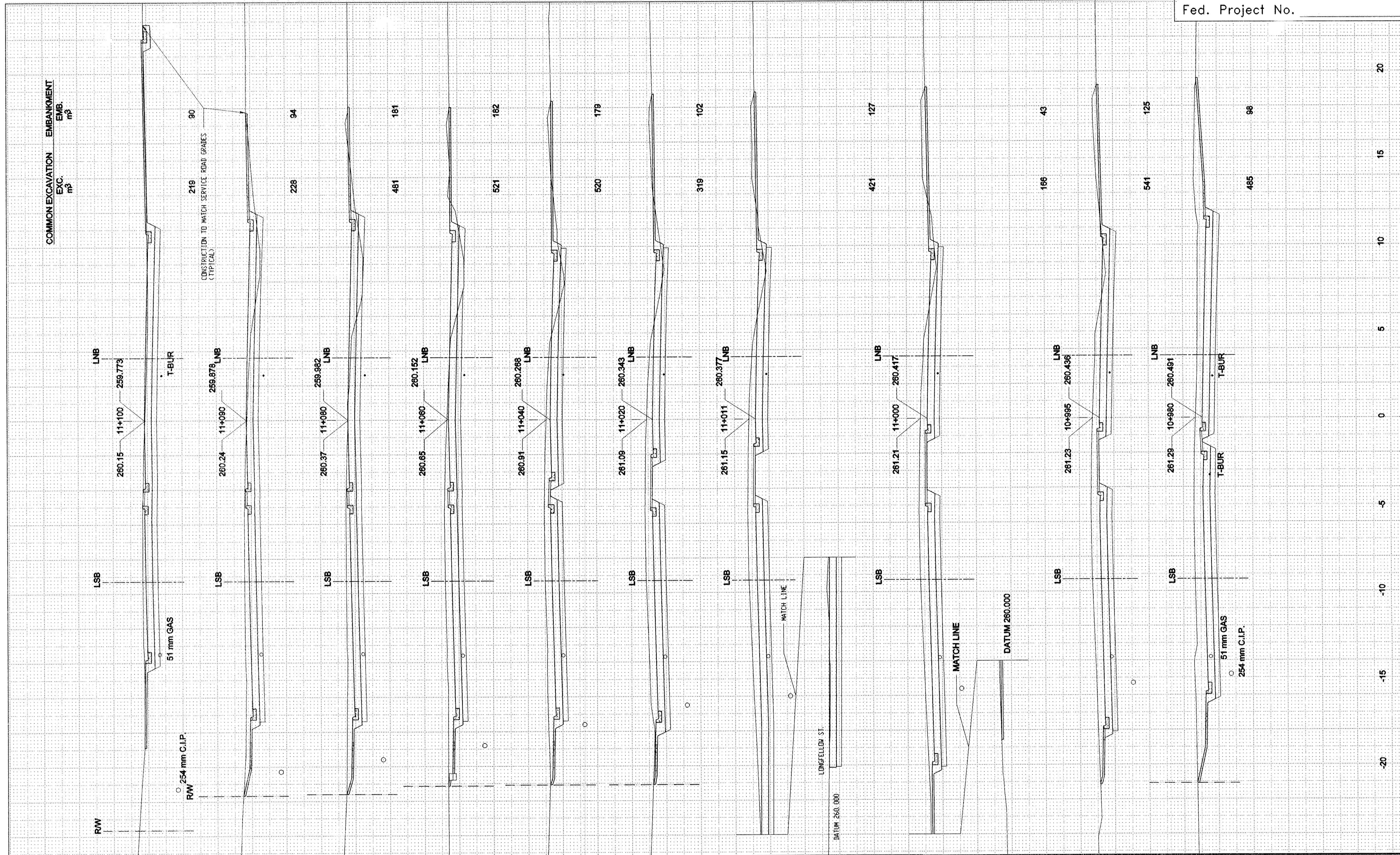

NO	DATE	BY	CKD	APPR	REVISION

NAME: SECT12.dwg 11-23-98 3:45:22 am EST



BY ME OR UNDER MY DIRECT SUPERVISION AND THAT I AM A DULY REGISTERED PROFESSIONAL ENGINEER UNDER THE LAWS OF THE STATE OF MINNESOTA.
 DATE _____ REG. NO. _____

DRAWN BY _____ DATE _____
 DESIGN BY _____ DATE _____
 CHECKED BY _____ DATE _____

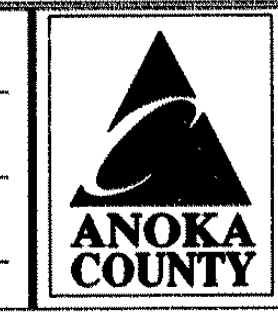

**ANOKA COUNTY
 HIGHWAY DEPT.**

STATE PROJECT NO. 02-601-37
 STATE PROJECT NO. 127-020-20
 STATE PROJECT NO. 114-020-18
 COUNTY PROJECT NO. _____

CROSS- SECTION
 STA 10+980.000 TO 11+100.000
 Sheet 49 of 93 Sheets

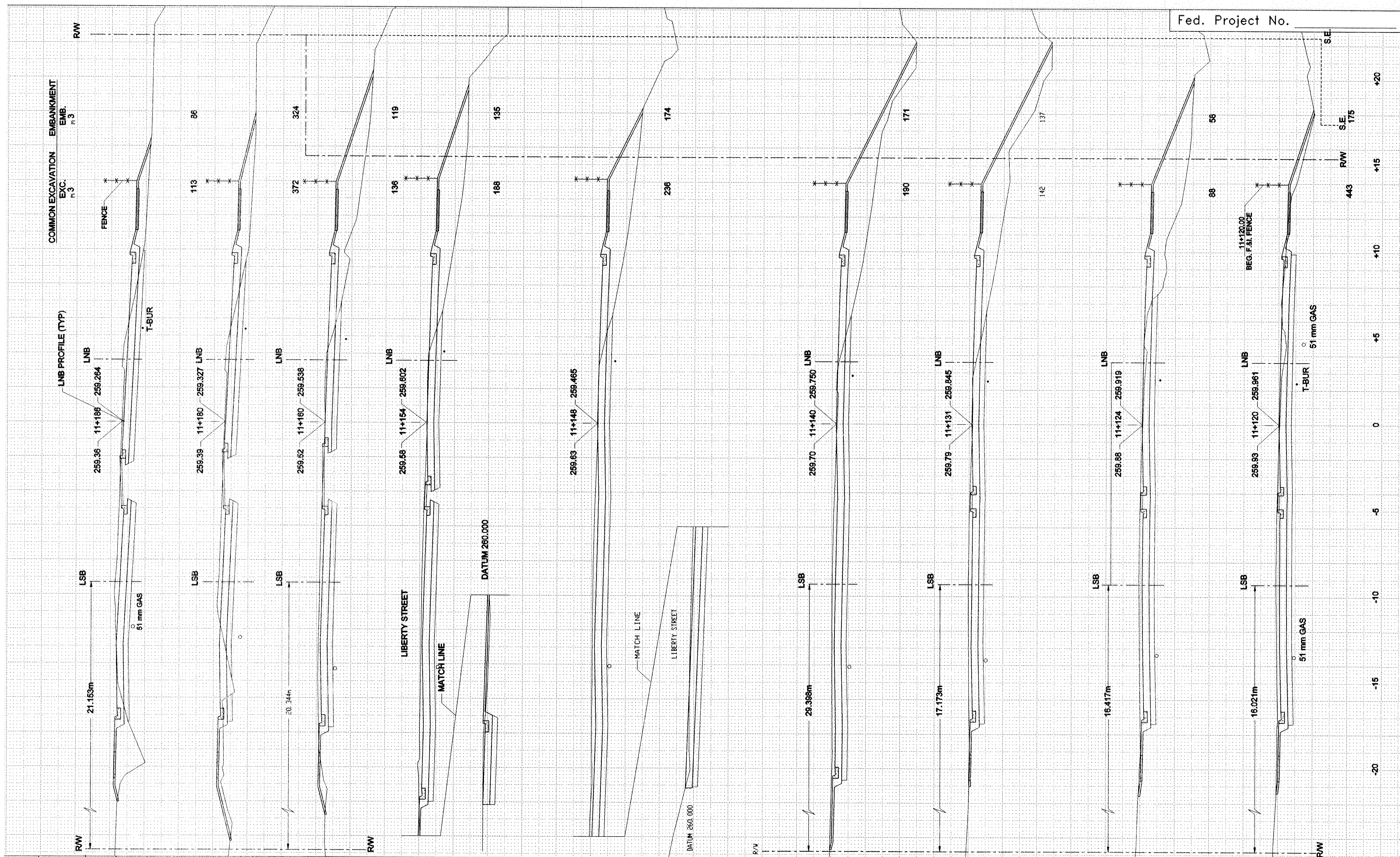

NO	DATE	BY	CKD	APPR	REVISION
NAME	SECT113.dwg	8-17-98	5:30:35 pm EST		

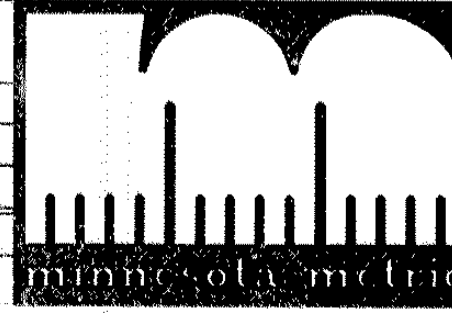

BY ME OR UNDER MY DIRECT SUPERVISION AND THAT I AM A DULY REGISTERED PROFESSIONAL ENGINEER UNDER THE LAWS OF THE STATE OF MINNESOTA.

DATE _____ REG. NO. _____

DRAWN BY _____ DATE _____
 DESIGN BY _____ DATE _____
 CHECKED BY _____ DATE _____

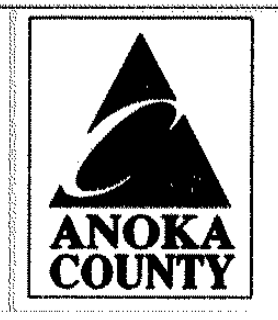

ANOKA COUNTY
HIGHWAY DEPT.

STATE PROJECT NO. 02-601-37
 STATE PROJECT NO. 127-020-20
 STATE PROJECT NO. 114-020-18
 COUNTY PROJECT NO. _____

CROSS-SECTION
 STA 11+120.000 TO 11+186.000
 Sheet 50 of 93 Sheets

COMMON EXCAVATION	EMBANKMENT
EXC. m ³	EMB. m ³

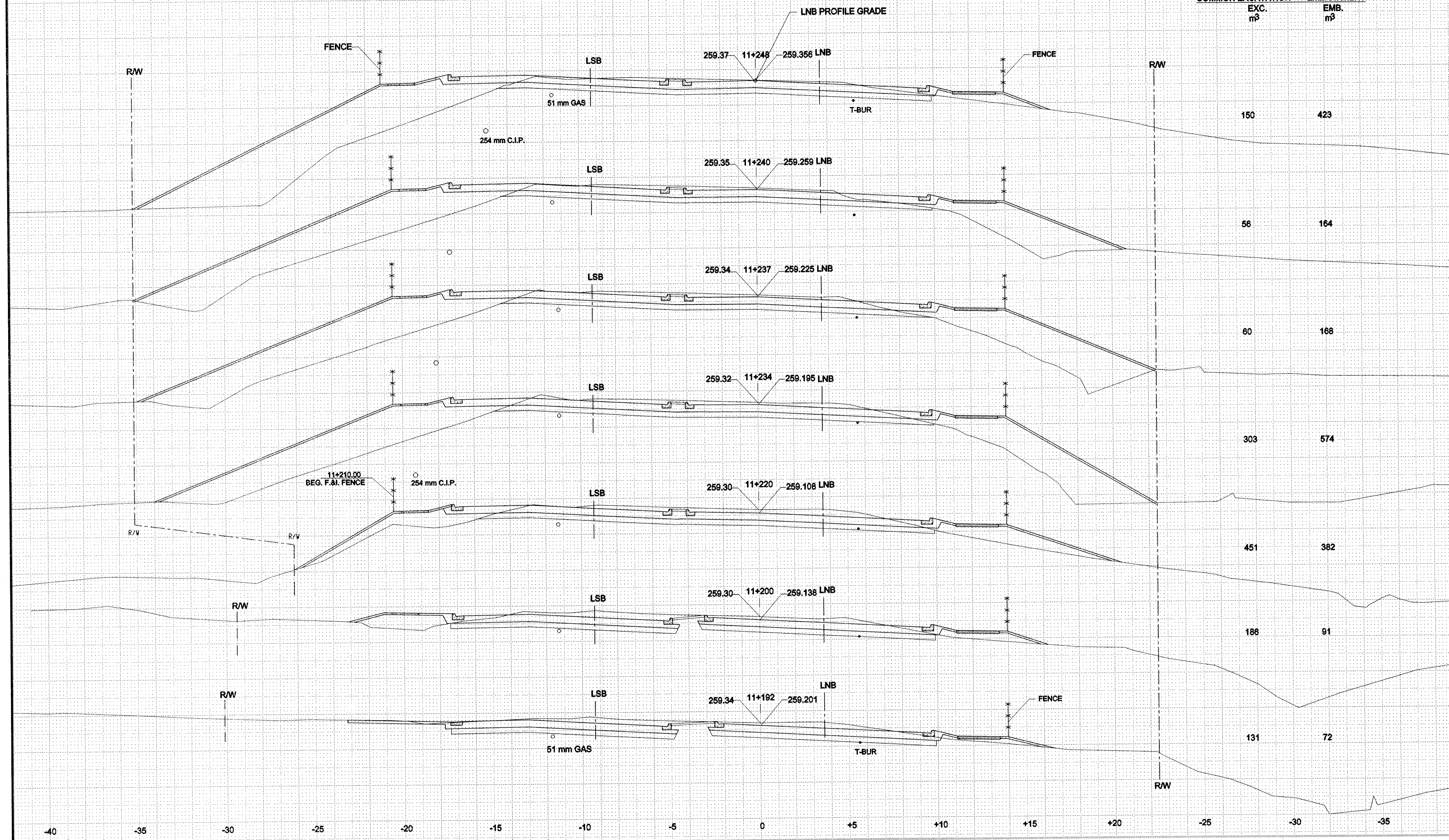

150	423
56	164
60	168
303	574
451	382
186	91
131	72

NO	DATE	BY	CKD	APPR	REVISION

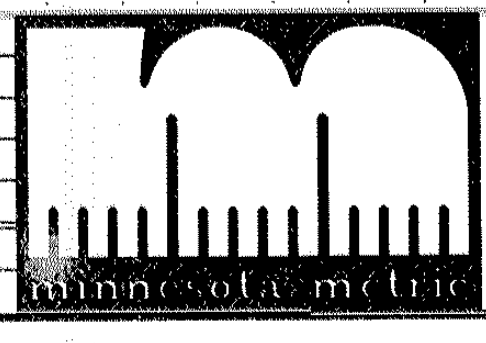

I HEREBY CERTIFY THAT THIS PLAN WAS PREPARED BY ME OR UNDER MY DIRECT SUPERVISION AND THAT I AM A DULY REGISTERED PROFESSIONAL ENGINEER UNDER THE LAWS OF THE STATE OF MINNESOTA.

DATE _____ REG. NO. _____

DRAWN BY _____ DATE _____
 DESIGN BY _____ DATE _____
 CHECKED BY _____ DATE _____



ANOKA COUNTY
HIGHWAY DEPT.

STATE PROJECT NO. 02-601-37
 STATE PROJECT NO. 127-020-20
 STATE PROJECT NO. 114-020-18
 COUNTY PROJECT NO. _____

CROSS-SECTION
 STA 11+192.000 TO 11+248.000
 Sheet 51 of 93 Sheets

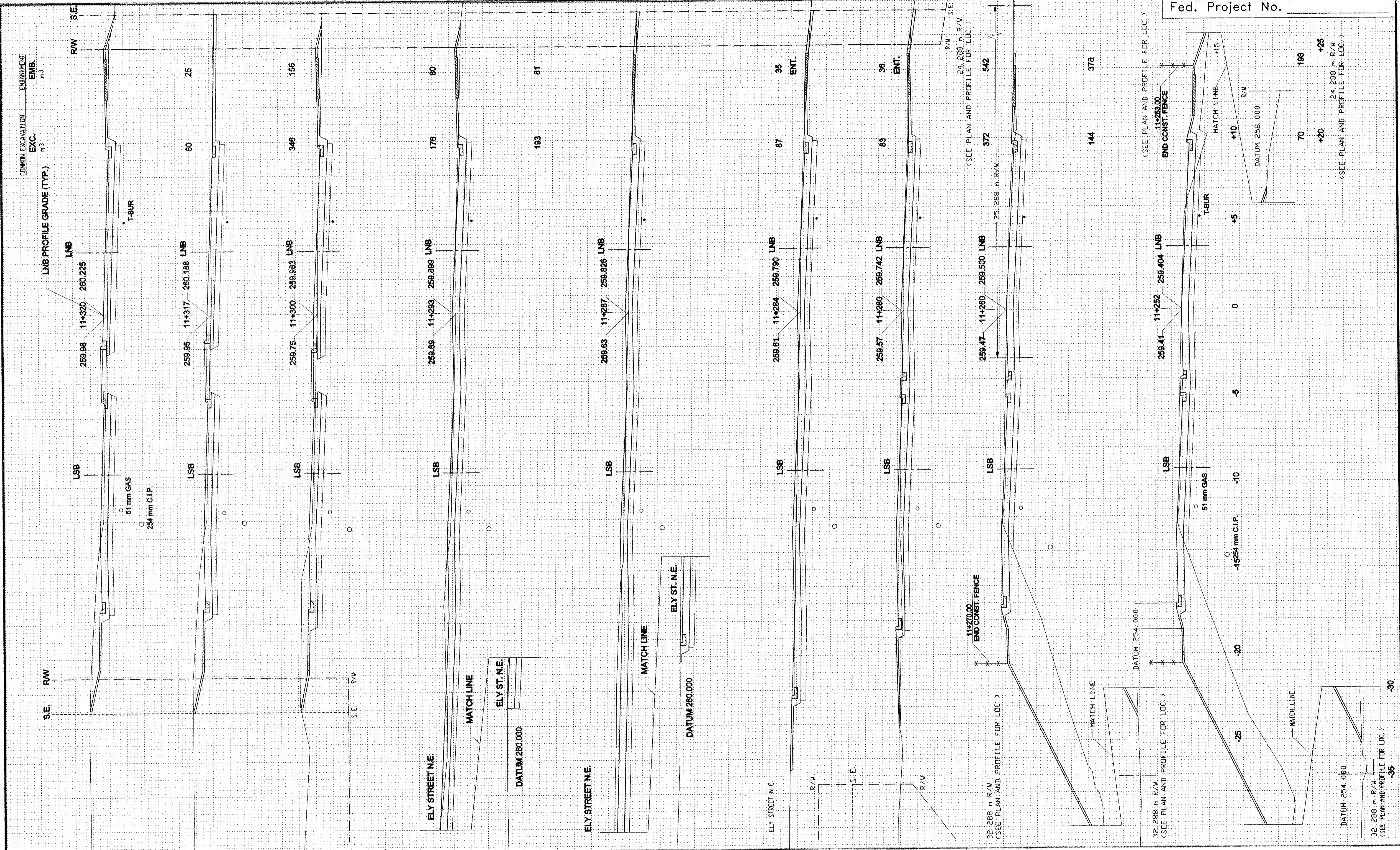

NO	DATE	BY	CKD	APPR	REVISION
1	8-17-98				

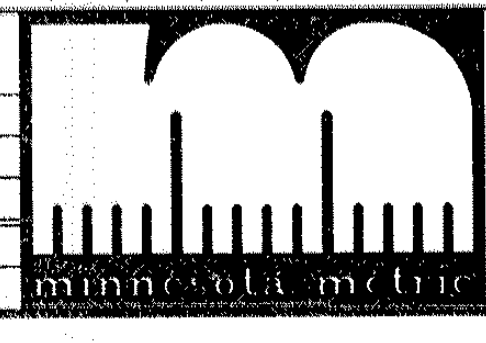

BY ME OR UNDER MY DIRECT SUPERVISION AND THAT I AM A DULY REGISTERED PROFESSIONAL ENGINEER UNDER THE LAWS OF THE STATE OF MINNESOTA.

DATE _____ REG. NO. _____

DRAWN BY _____ DATE _____
 DESIGN BY _____ DATE _____
 CHECKED BY _____ DATE _____

ANOKA COUNTY
HIGHWAY DEPT.

STATE PROJECT NO. 02-601-37
 STATE PROJECT NO. 127-020-20
 STATE PROJECT NO. 114-020-18
 COUNTY PROJECT NO. _____

CROSS- SECTION
 STA 11+252.000 TO 11+320.000
 Sheet 52 of 93 Sheets

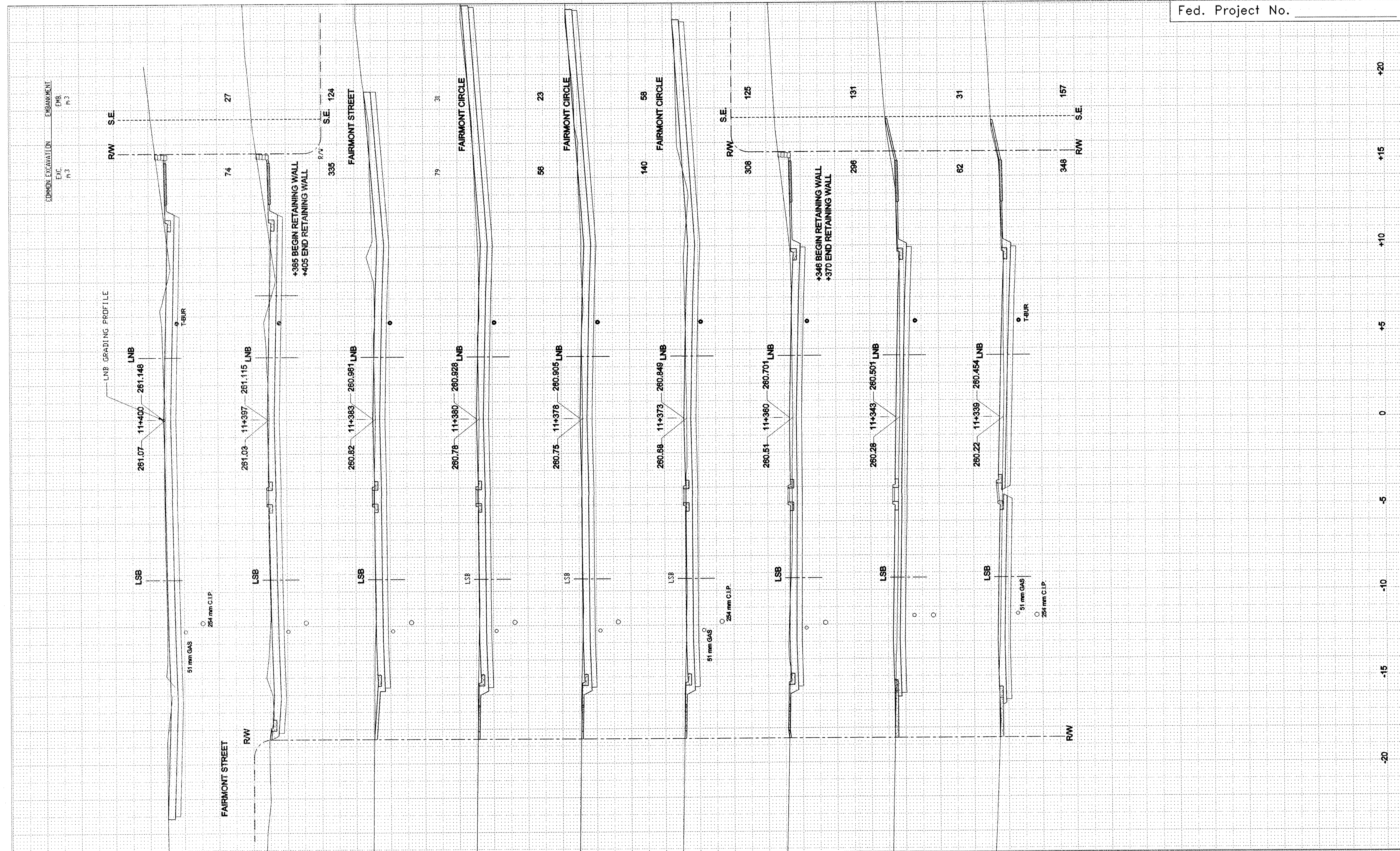

NO	DATE	BY	CKD	APPR	REVISION

NAME: SECT16.dwg 8-17-98 6:07:15 pm EST

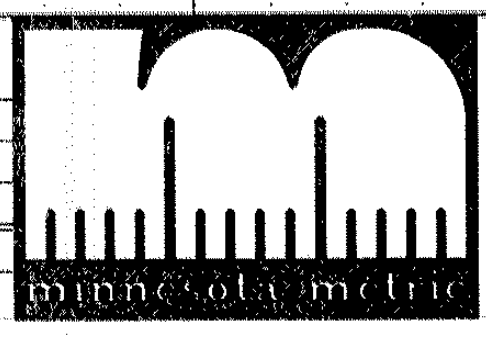

BY ME OR UNDER MY DIRECT SUPERVISION AND THAT I AM A DULY REGISTERED PROFESSIONAL ENGINEER UNDER THE LAWS OF THE STATE OF MINNESOTA.

DATE _____ REG. NO. _____

DRAWN BY _____ DATE _____
 DESIGN BY _____ DATE _____
 CHECKED BY _____ DATE _____



ANOKA COUNTY
HIGHWAY DEPT.

STATE PROJECT NO. 02-601-37
 STATE PROJECT NO. 127-020-20
 STATE PROJECT NO. 114-020-18
 COUNTY PROJECT NO. _____

CROSS- SECTION
 STA 11+339.000 TO 11+400.000
 Sheet 53 of 93 Sheets

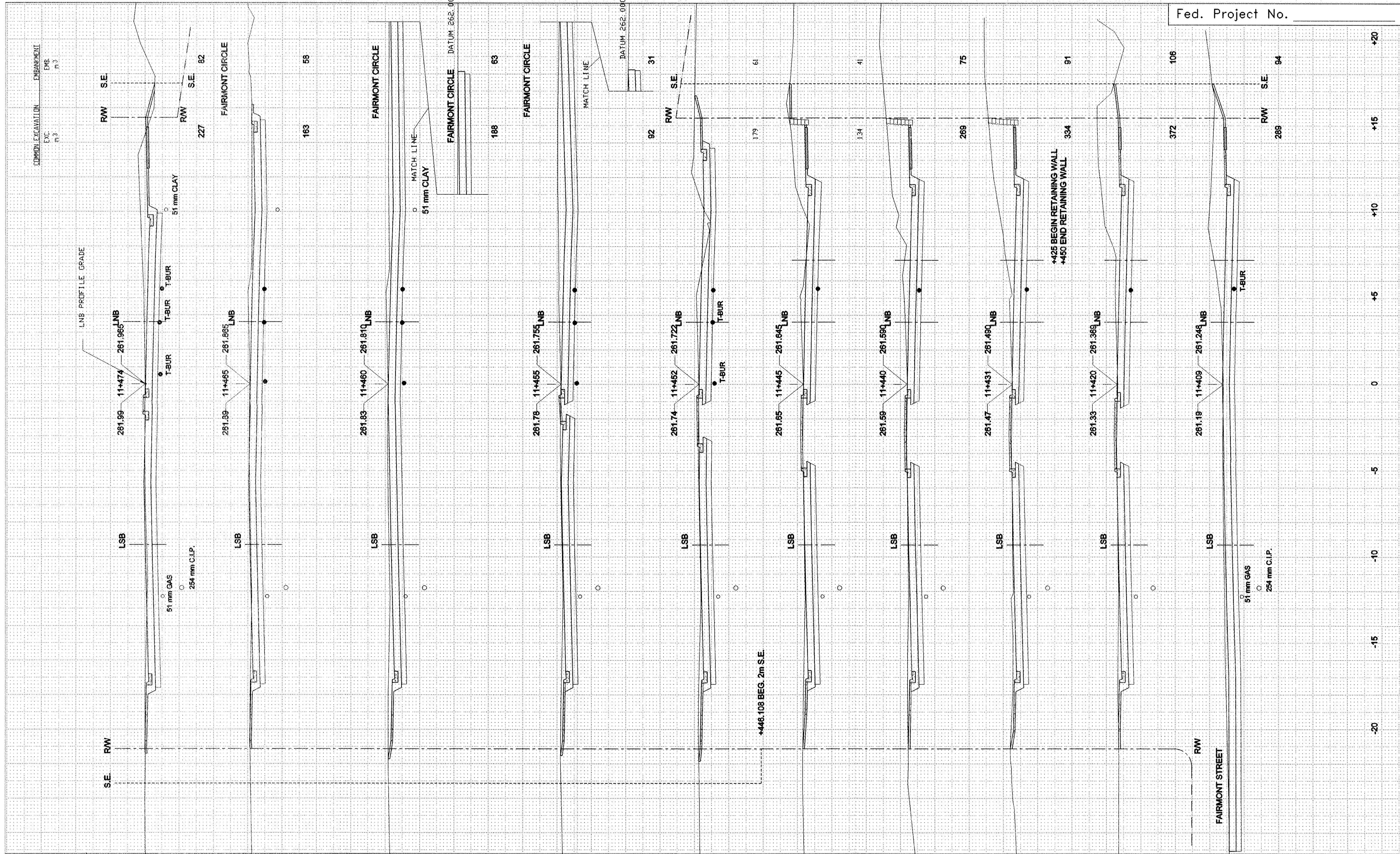

NO	DATE	BY	CKD	APPR	REVISION

NAME: SECT17.dwg 2/199 114454



BY ME OR UNDER MY DIRECT SUPERVISION AND THAT I AM A DULY REGISTERED PROFESSIONAL ENGINEER UNDER THE LAWS OF THE STATE OF MINNESOTA.

DATE _____ REG. NO. _____

DRAWN BY _____ DATE _____
 DESIGN BY _____ DATE _____
 CHECKED BY _____ DATE _____

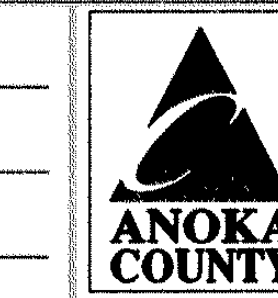

**ANOKA COUNTY
 HIGHWAY DEPT.**

STATE PROJECT NO. 02-601-37
 STATE PROJECT NO. 127-020-20
 STATE PROJECT NO. 114-020-18
 COUNTY PROJECT NO. _____

CROSS- SECTION
 STA 11+409.000 TO 11+474.000
 Sheet 54 of 93 Sheets

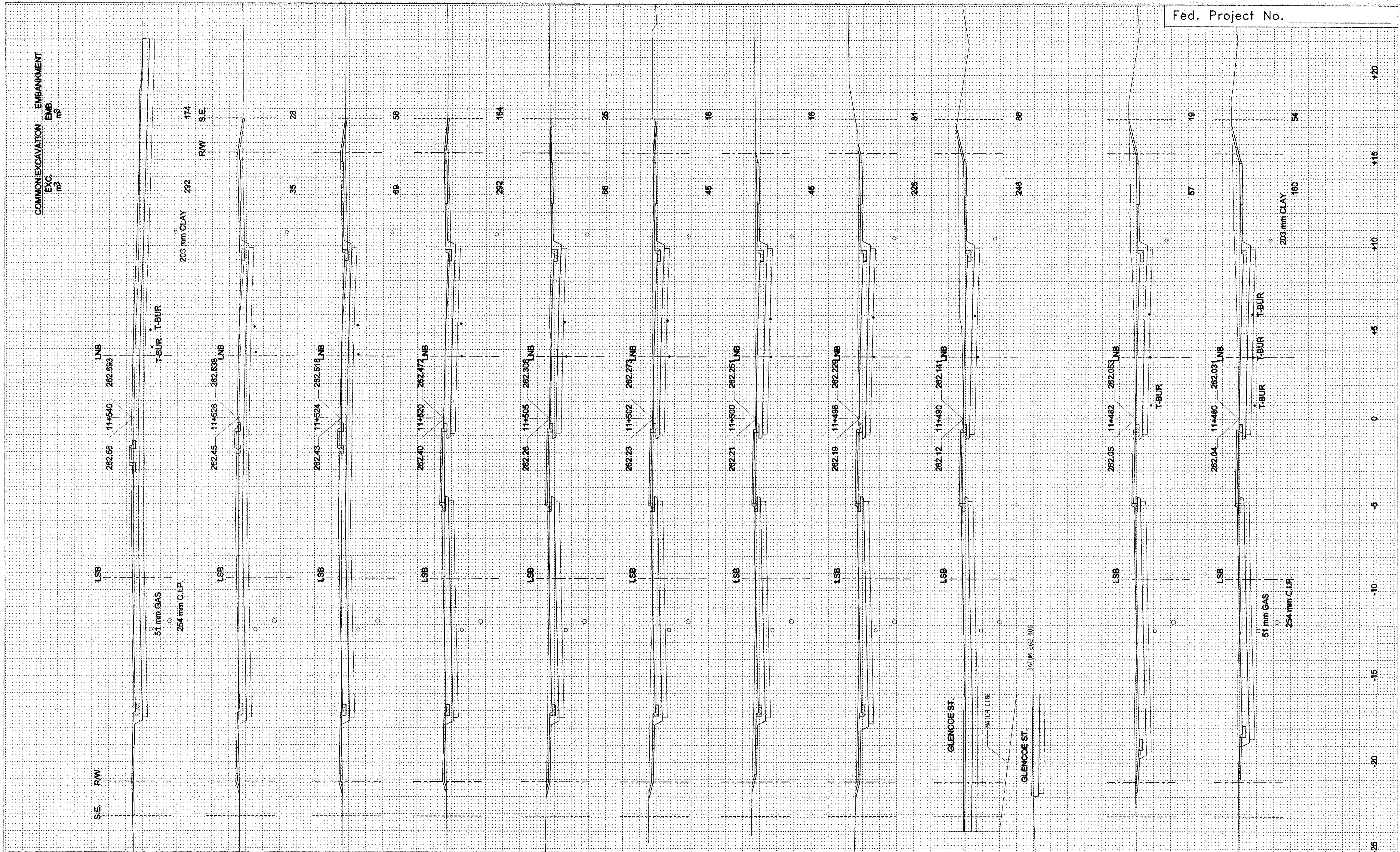

NO	DATE	BY	CKD	APPR	REVISION

NAME: SECT18.dwg 3499 115525

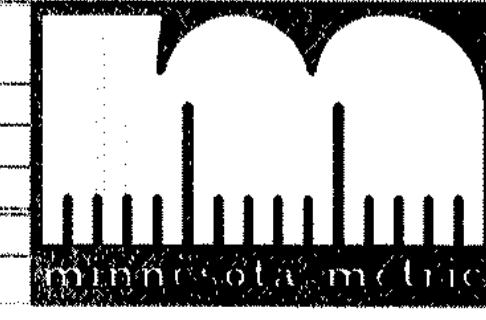

BY ME OR UNDER MY DIRECT SUPERVISION AND THAT I AM A DULY REGISTERED PROFESSIONAL ENGINEER UNDER THE LAWS OF THE STATE OF MINNESOTA.

DATE _____ REG. NO. _____

DRAWN BY _____ MN DATE 03/01/99
 DESIGN BY _____ KGJ DATE 03/01/99
 CHECKED BY _____ LR DATE 03/01/99



ANOKA COUNTY
 HIGHWAY DEPT.

STATE PROJECT NO. _____ 02-601-37
 STATE PROJECT NO. _____ 127-020-20
 STATE PROJECT NO. _____ 114-020-18
 COUNTY PROJECT NO. _____

CROSS-SECTION
 STA 11+480.000 TO 11+540.000
 Sheet 55 of 93 Sheets

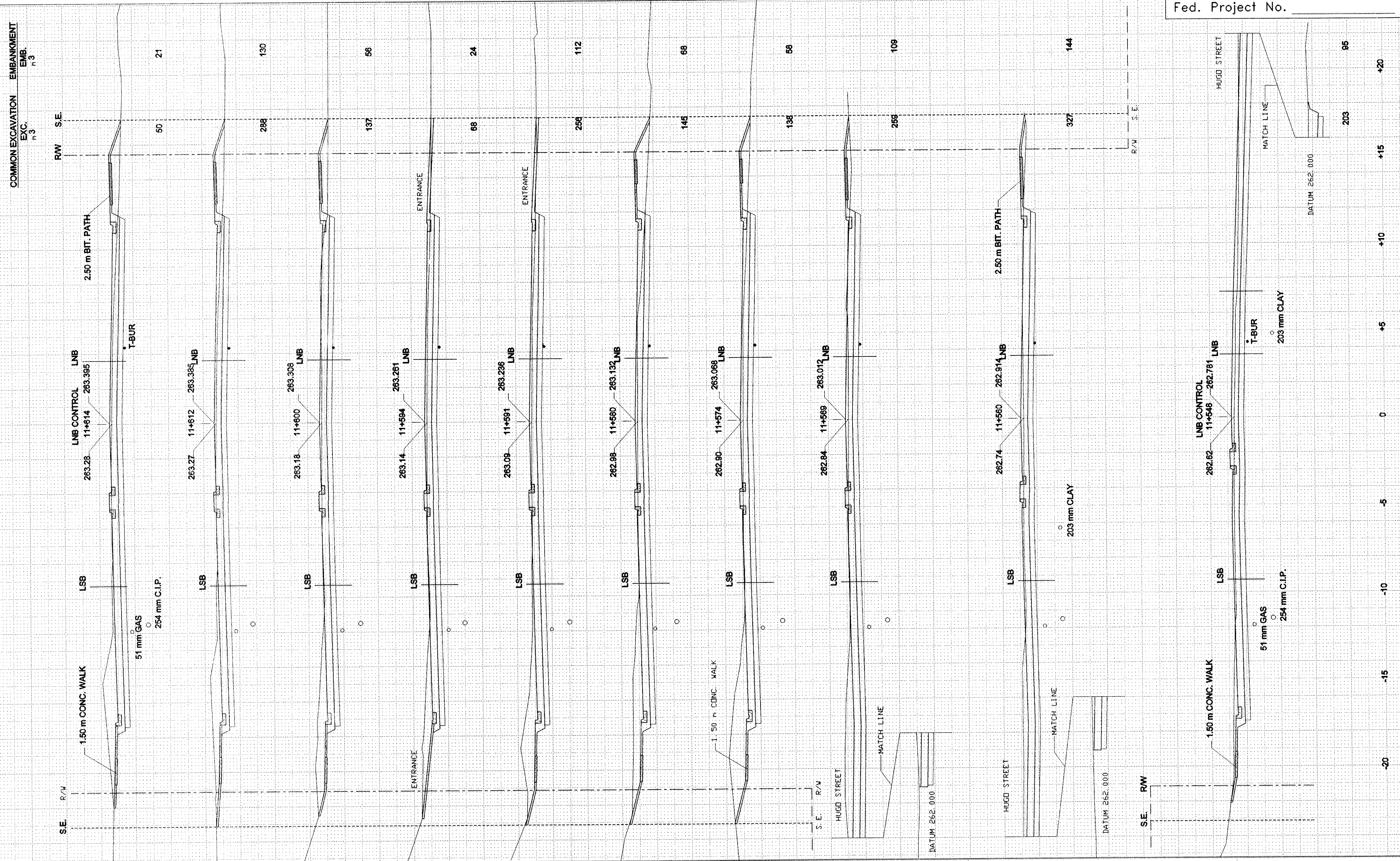

NO	DATE	BY	CKD	APPR	REVISION

NAME: SECT19.dwg 8-17-98 2:39:33 pm EST



BY ME OR UNDER MY DIRECT SUPERVISION AND THAT I AM A DULY REGISTERED PROFESSIONAL ENGINEER UNDER THE LAWS OF THE STATE OF MINNESOTA.

DATE _____ REG. NO. _____

DRAWN BY _____ DATE _____
 DESIGN BY _____ DATE _____
 CHECKED BY _____ DATE _____



ANOKA COUNTY
HIGHWAY DEPT.

STATE PROJECT NO. 02-601-37
 STATE PROJECT NO. 127-020-20
 STATE PROJECT NO. 114-020-18
 COUNTY PROJECT NO. _____

CROSS-SECTION
 STA 11+548.000 TO 11+614.000
 Sheet 56 of 93 Sheets

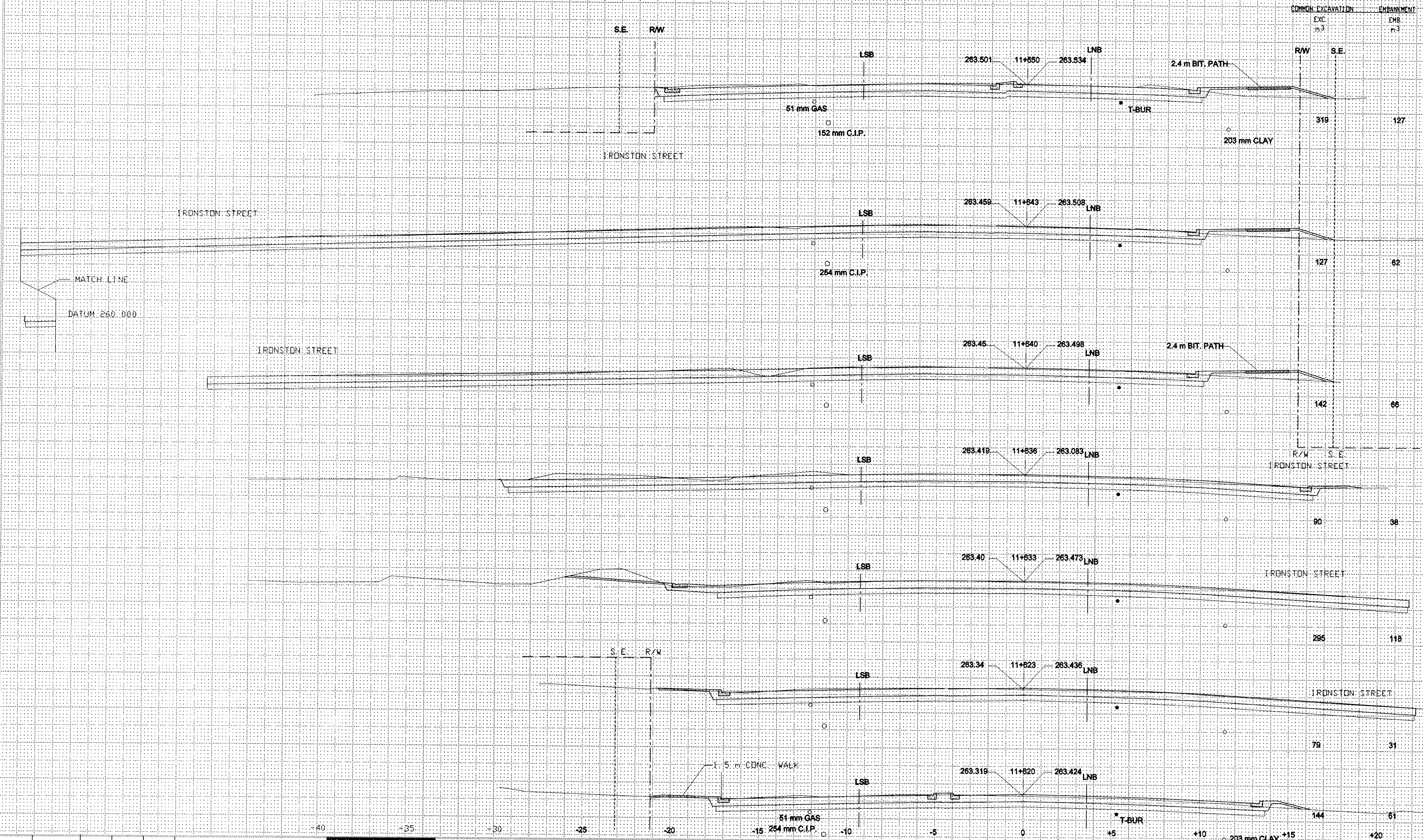

NO	DATE	BY	CKD	APPR	REVISION

NAME: SECT20.dwg 3-4-99 12:47:03 pm EST



I HEREBY CERTIFY THAT THIS PLAN WAS PREPARED BY ME OR UNDER MY DIRECT SUPERVISION AND THAT I AM A DULY REGISTERED PROFESSIONAL ENGINEER UNDER THE LAWS OF THE STATE OF MINNESOTA.

DATE _____ REG. NO. _____

DRAWN BY _____ MN DATE 03/01/99
 DESIGN BY _____ KGJ DATE 03/01/99
 CHECKED BY _____ LR DATE 03/01/99



**ANOKA COUNTY
 HIGHWAY DEPT.**

STATE PROJECT NO. 02-601-37
 STATE PROJECT NO. 127-020-20
 STATE PROJECT NO. 114-020-18
 COUNTY PROJECT NO. _____

CROSS-SECTION
 STA 11+620.000 TO 11+650.000
 Sheet 57 of 93 Sheets

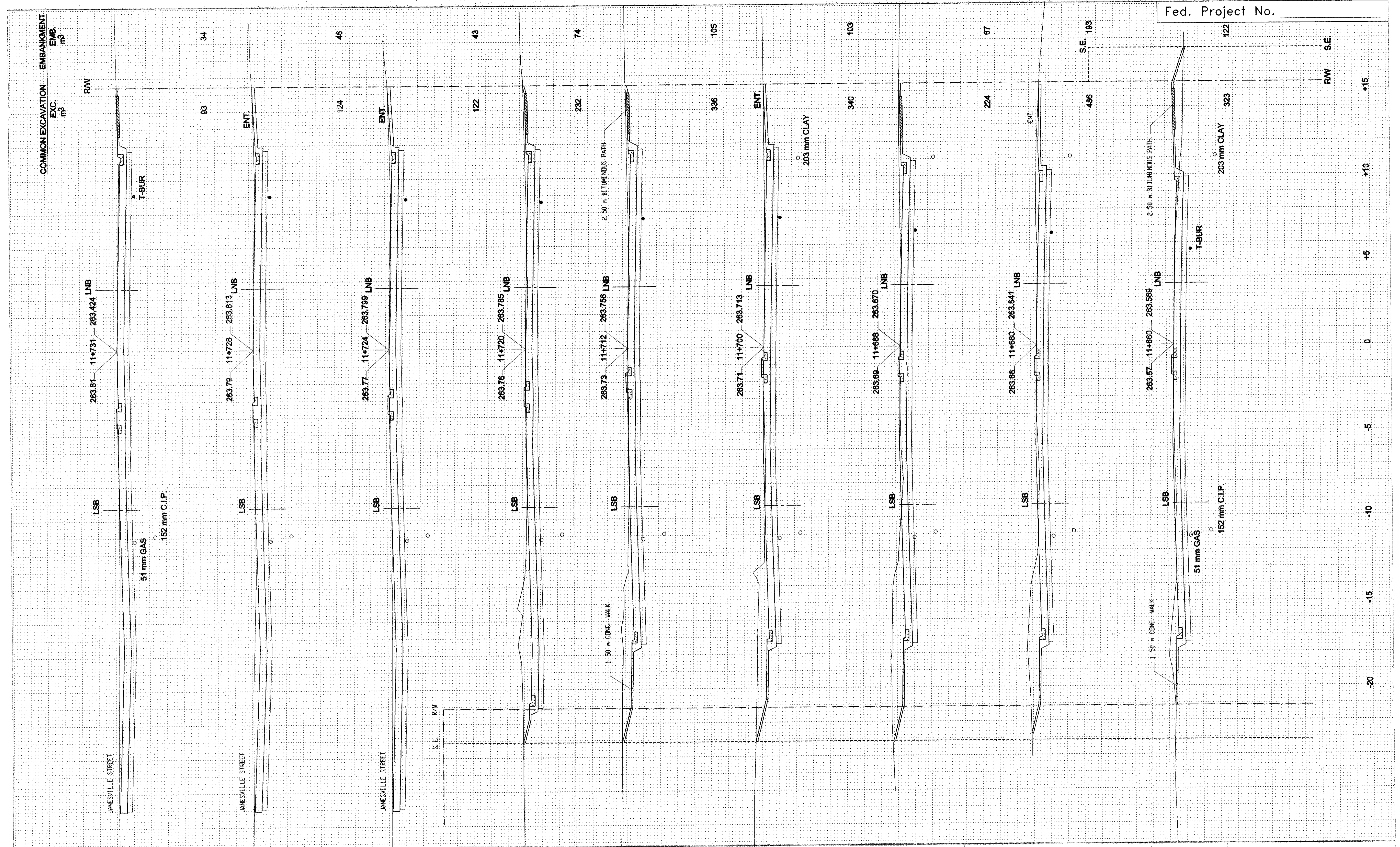

NO	DATE	BY	CKD	APPR	REVISION



BY ME OR UNDER MY DIRECT SUPERVISION AND THAT I AM A DULY REGISTERED PROFESSIONAL ENGINEER UNDER THE LAWS OF THE STATE OF MINNESOTA.

DATE _____ REG. NO. _____

DRAWN BY _____ DATE _____
 DESIGN BY _____ DATE _____
 CHECKED BY _____ DATE _____



**ANOKA COUNTY
HIGHWAY DEPT.**

STATE PROJECT NO. 02-601-37
 STATE PROJECT NO. 127-020-20
 STATE PROJECT NO. 114-020-18
 COUNTY PROJECT NO. _____

CROSS- SECTION
 STA 11+660.000 TO 11+731.000
 Sheet 58 of 93 Sheets

COMMON EXCAVATION EMBANKMENT
 EXC EMB
 m³ m³

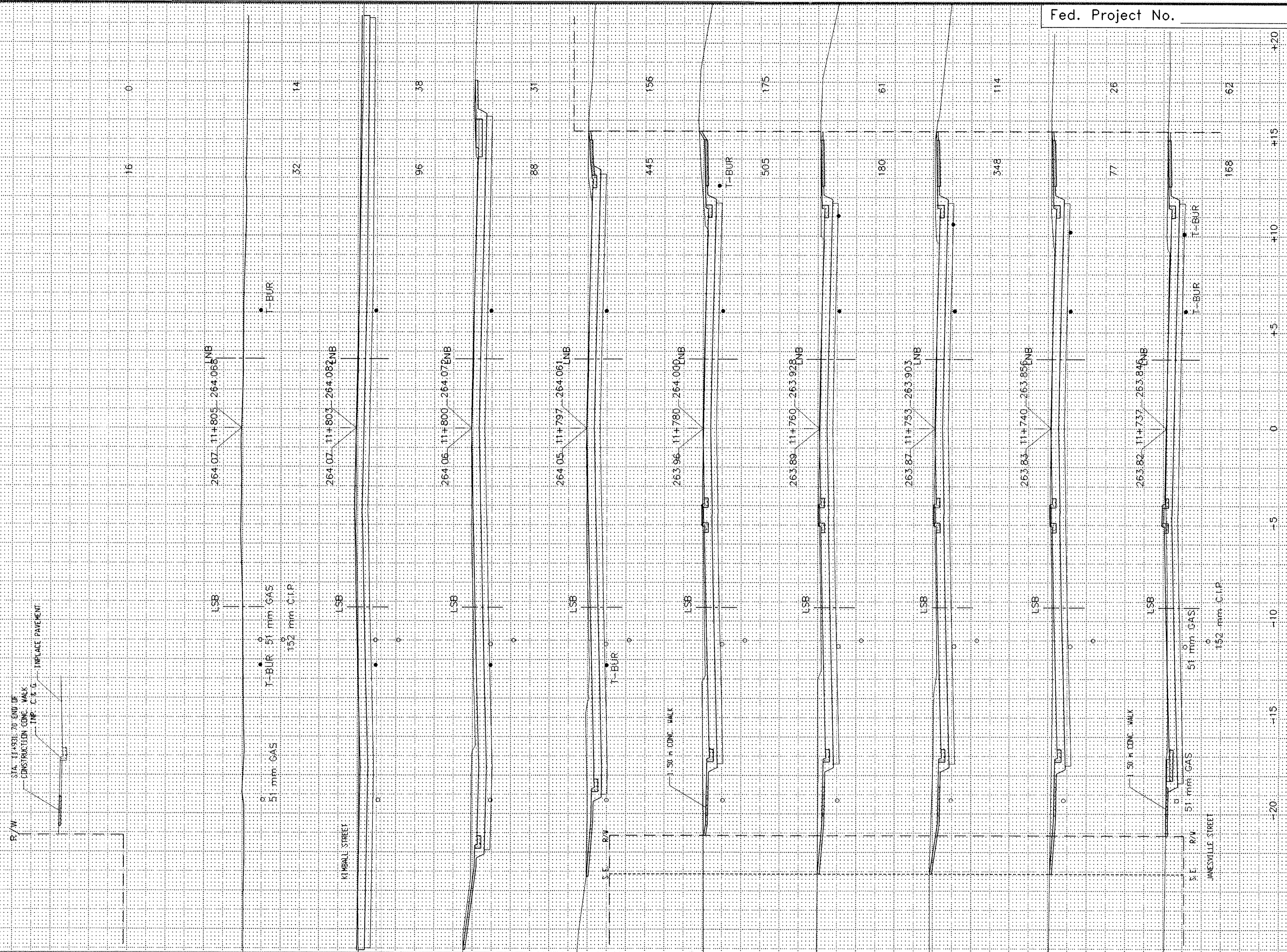
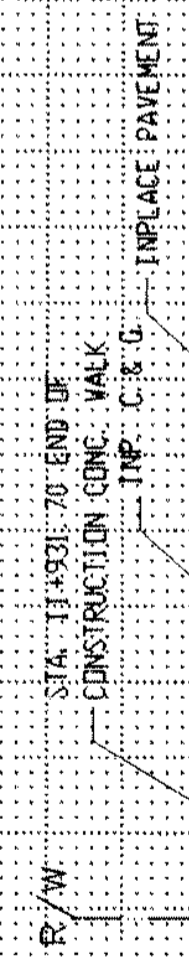

NO	DATE	BY	CKD	APPR	REVISION
NAME	SECT22.dwg	3499	10315		

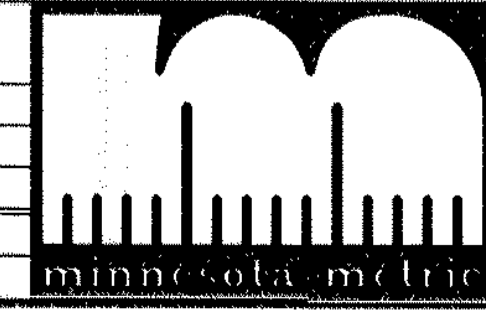

BY ME OR UNDER MY DIRECT SUPERVISION AND THAT I AM A DULY REGISTERED PROFESSIONAL ENGINEER UNDER THE LAWS OF THE STATE OF MINNESOTA.
 DATE _____ REG. NO. _____

DRAWN BY _____ MN DATE 03/01/99
 DESIGN BY _____ KGJ DATE 03/01/99
 CHECKED BY _____ LR DATE 03/01/99



ANOKA COUNTY
 HIGHWAY DEPT.

STATE PROJECT NO. _____ 02-601-37
 STATE PROJECT NO. _____ 127-020-20
 STATE PROJECT NO. _____ 114-020-18
 COUNTY PROJECT NO. _____

CROSS-SECTION
 STA 11+737.000 TO 11+805.000
 Sheet 59 of 93 Sheets

NOTES:

- 1) ALL TRAFFIC CONTROL DEVICES SHALL CONFORM TO THE MINNESOTA MANUAL ON UNIFORM TRAFFIC CONTROL DEVICES, INCLUDING THE FIELD MANUAL DATED JANUARY, 1998
- 2) ALL TYPE 111 BARRICADES SHALL BE REFLECTORIZED ON BOTH SIDES BARRICADE MARKINGS SHALL BE SLANTED IN ACCORDANCE WITH THE Mn. MUTCD.

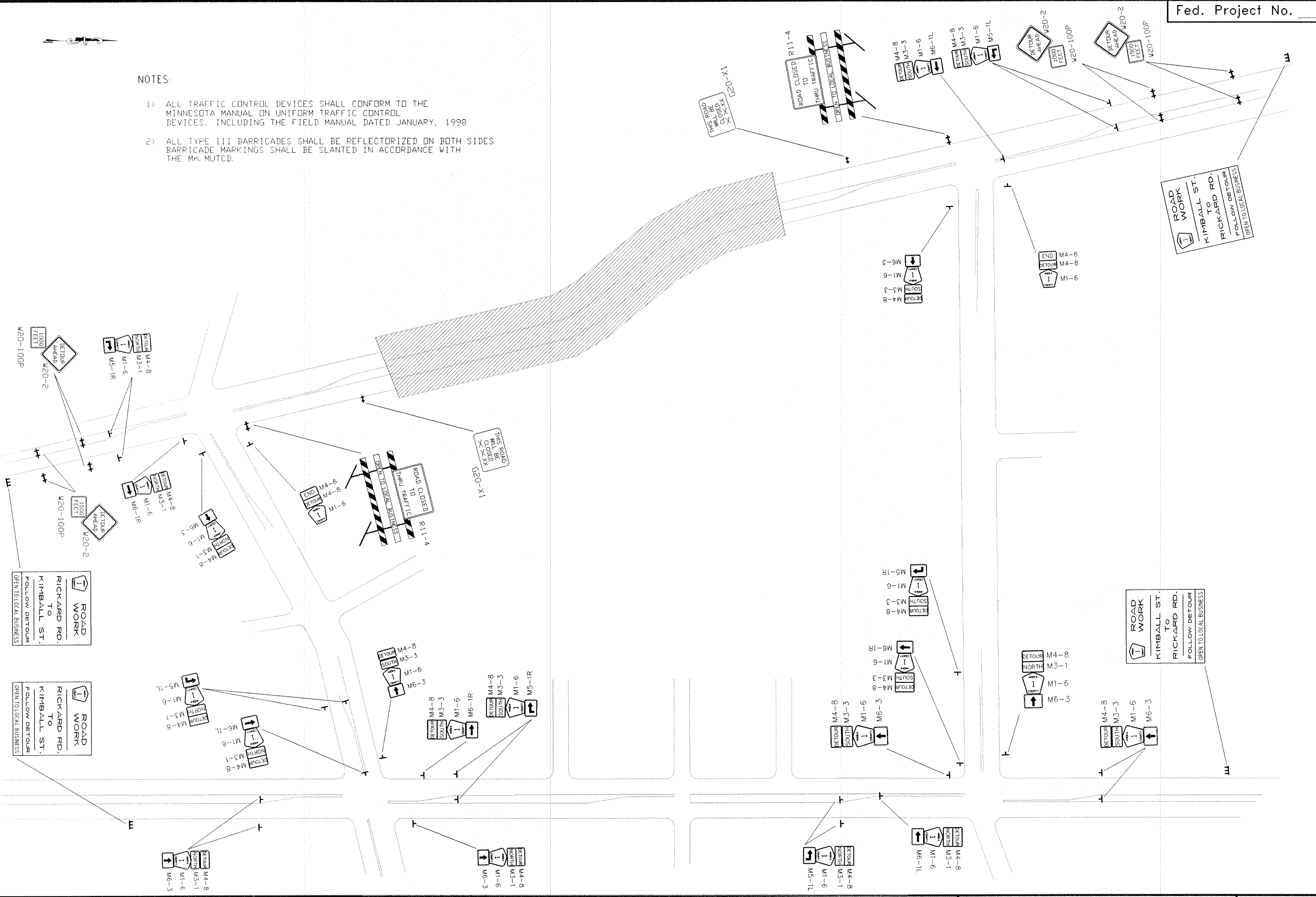

NO	DATE	BY	CKD	APPR	REVISION

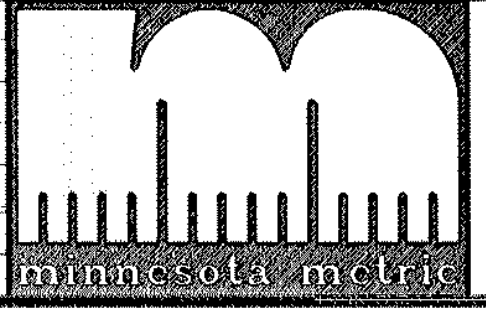

I HEREBY CERTIFY THAT THIS PLAN WAS PREPARED BY ME OR UNDER MY DIRECT SUPERVISION AND THAT I AM A DULY REGISTERED PROFESSIONAL ENGINEER UNDER THE LAWS OF THE STATE OF MINNESOTA.

DATE _____ REG. NO. _____











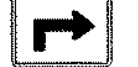

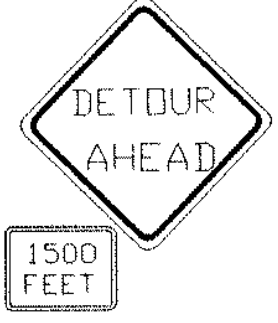
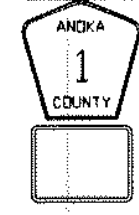



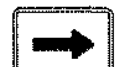

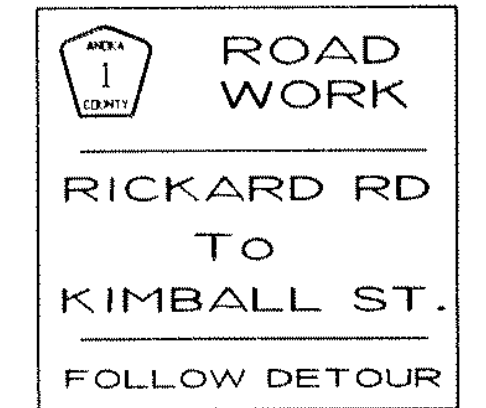
DRAWN BY D.M. DATE 3/98
 DESIGN BY D.M. DATE 3/98
 CHECKED BY J.P./R.B. DATE 6/98

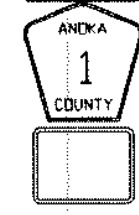
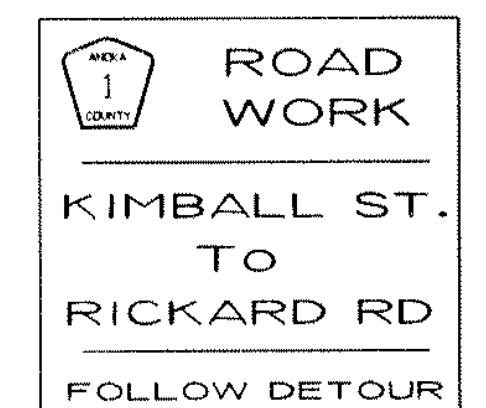

ANOKA COUNTY
 HIGHWAY DEPT.

STATE PROJECT NO. 02-601-37
 STATE AID PROJECT NO. 127-020-20
 STATE AID PROJECT NO. 114-020-18
 COUNTY PROJECT NO. _____

DETOUR C.S.A.H. 1
 Sheet 60 of 93 Sheets

M. U. T. C. D. CODE	SIZE	INSERT	QUANTITY	M. U. T. C. D. CODE	SIZE	INSERT	QUANTITY	
W20-2	48" x 48"		• 4	M4-8	24" x 12"	M5-1R 	• 2	
W20-100P	24" x 18"			M3-1	24" x 12"		M5-1L 	• 4
W20-2	48" x 48"		• 4	M1-6	24" x 24"		M6-1L 	• 2
W20-100P	24" x 18"					21" x 15"		M6-3 
R11-4	60" x 30"		• 2			M6-1R 	• 1	
SIGN SPECIAL TYPE 111	96" x 12" 8 FOOT					M4-8	24" x 12"	
G20-X2	96" x 84"		• 2	M3-3	24" x 12"	M5-1R 	• 3	
SIGN SPECIAL	96" x 12"					M1-6	24" x 24"	
G20-X2	96" x 84"		• 2			M6-1L 	• 1	
SIGN SPECIAL	96" x 12"							M6-3 
G20-X1	60" x 48"		• 2	M4-6	24" x 12"			
				M4-8	24" x 12"			
				M1-6	24" x 24"		• 2	

LETTER SIZE "6C"
BLACK ON ORANGE

LETTER SIZE "6C"
BLACK ON ORANGE

SIGN TO BE INSTALLED A MINIMUM OF TEN DAYS
PRIOR TO ACTUAL CLOSING DATE OF ROAD
CLOSURE AND IMPLEMENTATION OF DETOUR SIGNING.
SIGNS TO BE REMOVED AT TIME OF DETOUR INSTALLATION.

NOTES:

- 1) ALL TRAFFIC CONTROL DEVICES SHALL CONFORM TO THE MINNESOTA MANUAL ON UNIFORM TRAFFIC CONTROL DEVICES, INCLUDING THE FIELD MANUAL DATED JANUARY, 1998
- 2) ALL BARRICADES SHALL BE REFLECTORIZED ON BOTH SIDES. BARRICADE MARKINGS SHALL BE SLANTED IN ACCORDANCE WITH THE Mn. MUTCD.

NO	DATE	BY	CKD	APPR	REVISION



I HEREBY CERTIFY THAT THIS PLAN WAS PREPARED BY ME OR UNDER MY DIRECT SUPERVISION AND THAT I AM A DULY REGISTERED PROFESSIONAL ENGINEER UNDER THE LAWS OF THE STATE OF MINNESOTA.

DATE _____ REG. NO. _____

DRAWN BY DM DATE 3/98
 DESIGN BY DM DATE 3/98
 CHECKED BY JP / R.R. DATE 6/98



ANOKA COUNTY
HIGHWAY DEPT.

STATE PROJECT NO. 02-601-37
 STATE AID PROJECT NO. 127-020-20
 STATE AID PROJECT NO. 114-020-18
 COUNTY PROJECT NO. _____

DETOUR QUANTITY
C.S.A.H. 1
Sheet 61 of 93 Sheets

NOTES:

- 1.) LOCATIONS OF 'NO PASSING ZONES' ARE APPROXIMATE. EXACT LOCATIONS WILL BE DETERMINED IN THE FIELD.
- 2.) ALL TRAFFIC CONTROL DEVICES SHALL CONFORM THE MOST RECENT EDITION OF THE MINNESOTA MANUAL ON UNIFORM TRAFFIC CONTROL DEVICES, INCLUDING THE FIELD MANUAL DATED JANUARY 1998.

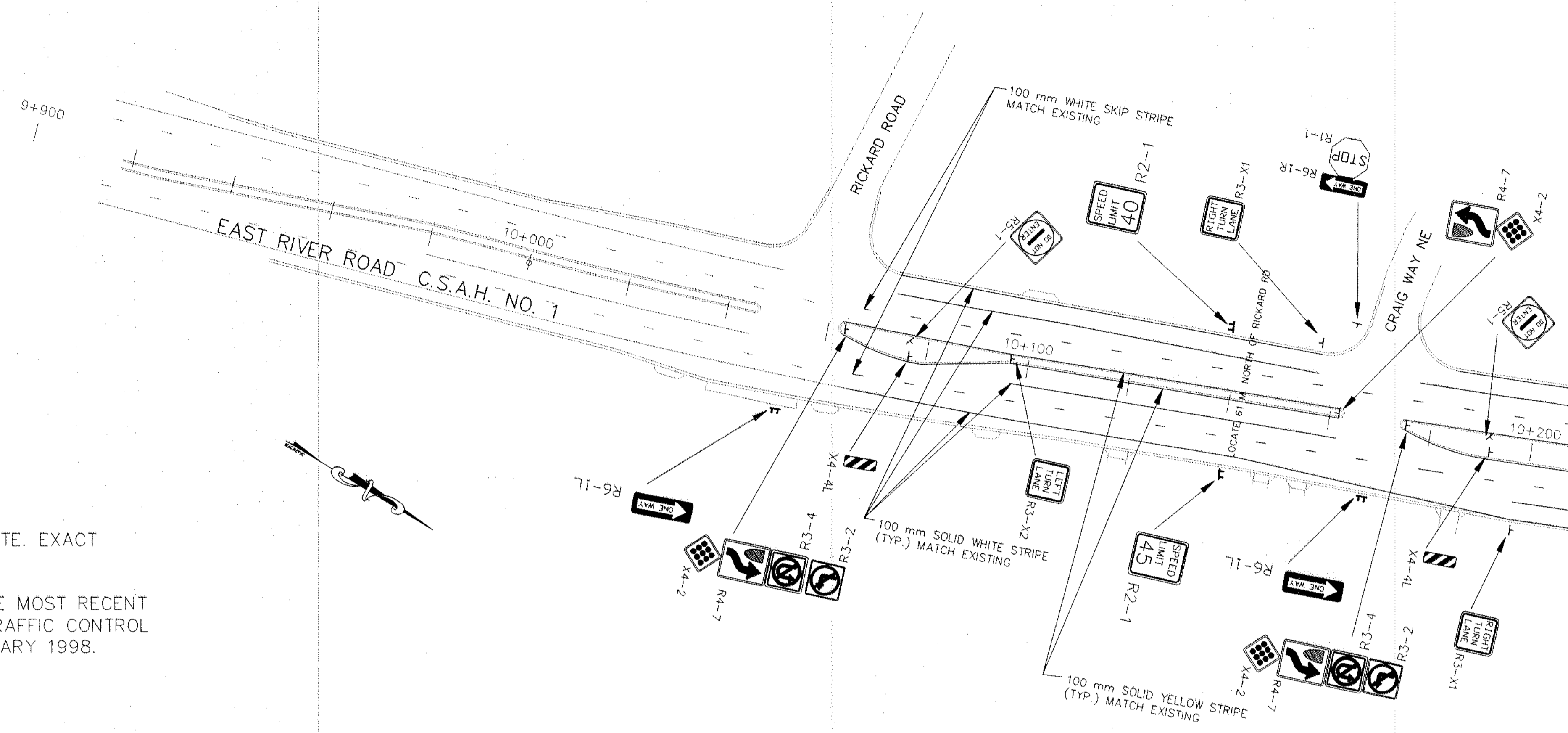

MATCHLINE 'A' STA. 10+211 SEE SHEET 63 of 93

NO	DATE	BY	CKD	APPR	REVISION

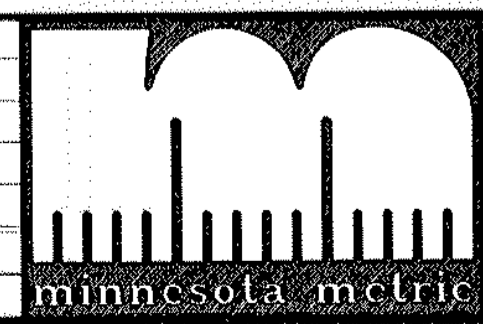

I HEREBY CERTIFY THAT THIS PLAN WAS PREPARED BY ME OR UNDER MY DIRECT SUPERVISION AND THAT I AM A DULY REGISTERED PROFESSIONAL ENGINEER UNDER THE LAWS OF THE STATE OF MINNESOTA.

DATE _____ REG. NO. _____

DRAWN BY _____ DATE _____
 DESIGN BY _____ DATE _____
 CHECKED BY _____ DATE _____



ANOKA COUNTY
HIGHWAY DEPT.

STATE PROJECT NO. 02-601-37
 STATE PROJECT NO. 127-020-20
 STATE AID PROJECT NO. 114-020-18
 COUNTY PROJECT NO. _____

SIGNING / STRIPING DETAILS
 Sheet 62 of 93 Sheets

MATCHLINE 'A' STA. 10+211 SEE SHEET 62 of 93

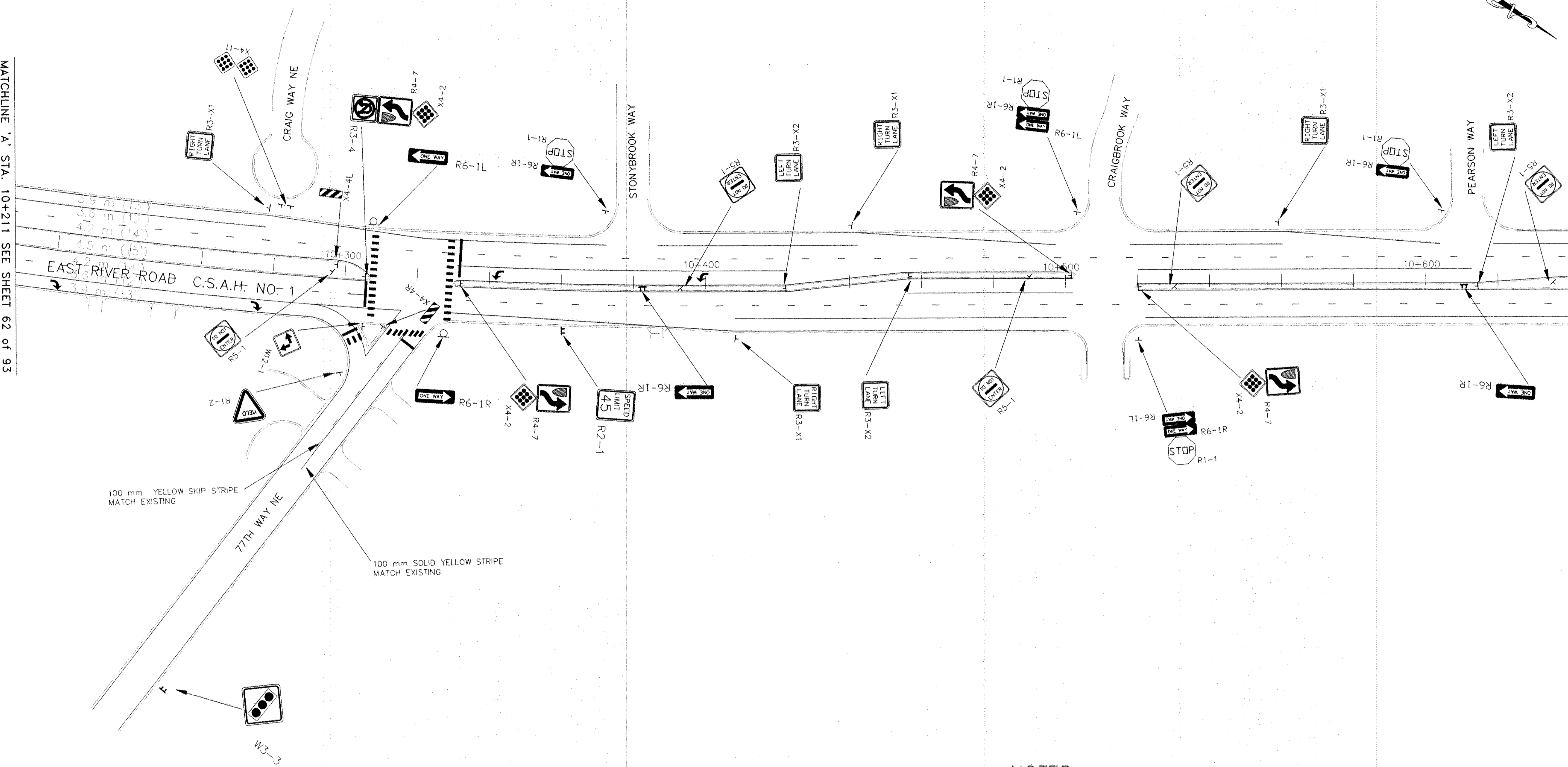

MATCHLINE 'B' STA. 10+640 SEE SHEET 64 of 93

NOTES:

- 1.) LOCATIONS OF 'NO PASSING ZONES' ARE APPROXIMATE. EXACT LOCATIONS WILL BE DETERMINED IN THE FIELD.
- 2.) ALL TRAFFIC CONTROL DEVICES SHALL CONFORM THE MOST RECENT EDITION OF THE MINNESOTA MANUAL ON UNIFORM TRAFFIC CONTROL DEVICES, INCLUDING THE FIELD MANUAL DATED JANUARY 1998.

NO	DATE	BY	CKD	APPR	REVISION

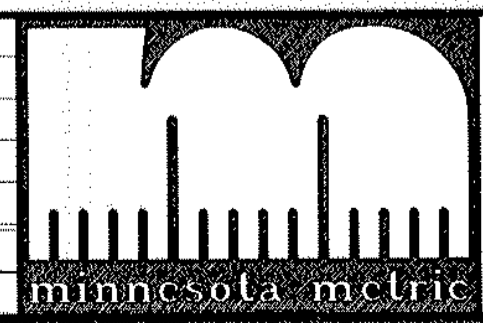

I HEREBY CERTIFY THAT THIS PLAN WAS PREPARED BY ME OR UNDER MY DIRECT SUPERVISION AND THAT I AM A DULY REGISTERED PROFESSIONAL ENGINEER UNDER THE LAWS OF THE STATE OF MINNESOTA.

DATE _____ REG. NO. _____

DRAWN BY _____ DATE _____
 DESIGN BY _____ DATE _____
 CHECKED BY _____ DATE _____



ANOKA COUNTY
HIGHWAY DEPT.

STATE PROJECT NO. 02-601-37
 STATE PROJECT NO. 127-020-20
 STATE AID PROJECT NO. 114-020-18
 COUNTY PROJECT NO. _____

SIGNING /
 STRIPING DETAILS

Sheet 63 of 93 Sheets

MATCHLINE 'B' STA. 10+640 SEE SHEET 63 OF 93

MATCHLINE 'C' STA. 11+072 SEE SHEET 65 OF 93

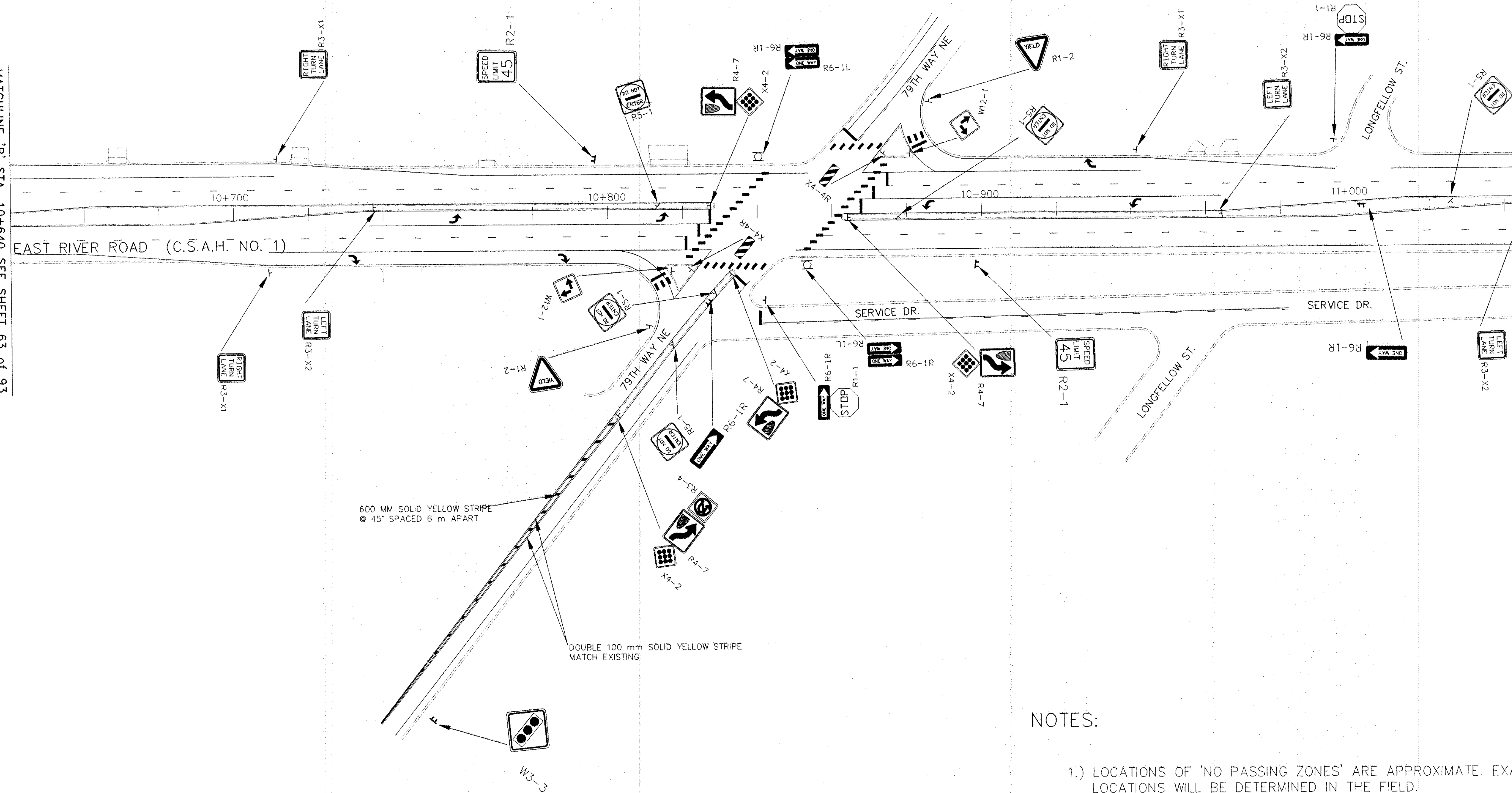

NOTES:

- 1.) LOCATIONS OF 'NO PASSING ZONES' ARE APPROXIMATE. EXACT LOCATIONS WILL BE DETERMINED IN THE FIELD.
- 2.) ALL TRAFFIC CONTROL DEVICES SHALL CONFORM THE MOST RECENT EDITION OF THE MINNESOTA MANUAL ON UNIFORM TRAFFIC CONTROL DEVICES, INCLUDING THE FIELD MANUAL DATED JANUARY 1998.

NO	DATE	BY	CKD	APPR	REVISION



I HEREBY CERTIFY THAT THIS PLAN WAS PREPARED BY ME OR UNDER MY DIRECT SUPERVISION AND THAT I AM A DULY REGISTERED PROFESSIONAL ENGINEER UNDER THE LAWS OF THE STATE OF MINNESOTA.

DATE _____ REG. NO. _____

DRAWN BY _____ DATE _____
 DESIGN BY _____ DATE _____
 CHECKED BY _____ DATE _____



ANOKA COUNTY
HIGHWAY DEPT.

STATE PROJECT NO. 02-601-37
 STATE PROJECT NO. 127-020-20
 STATE AID PROJECT NO. 114-020-18
 COUNTY PROJECT NO. _____

SIGNING /
STRIPING DETAILS

Sheet 64 of 93 Sheets

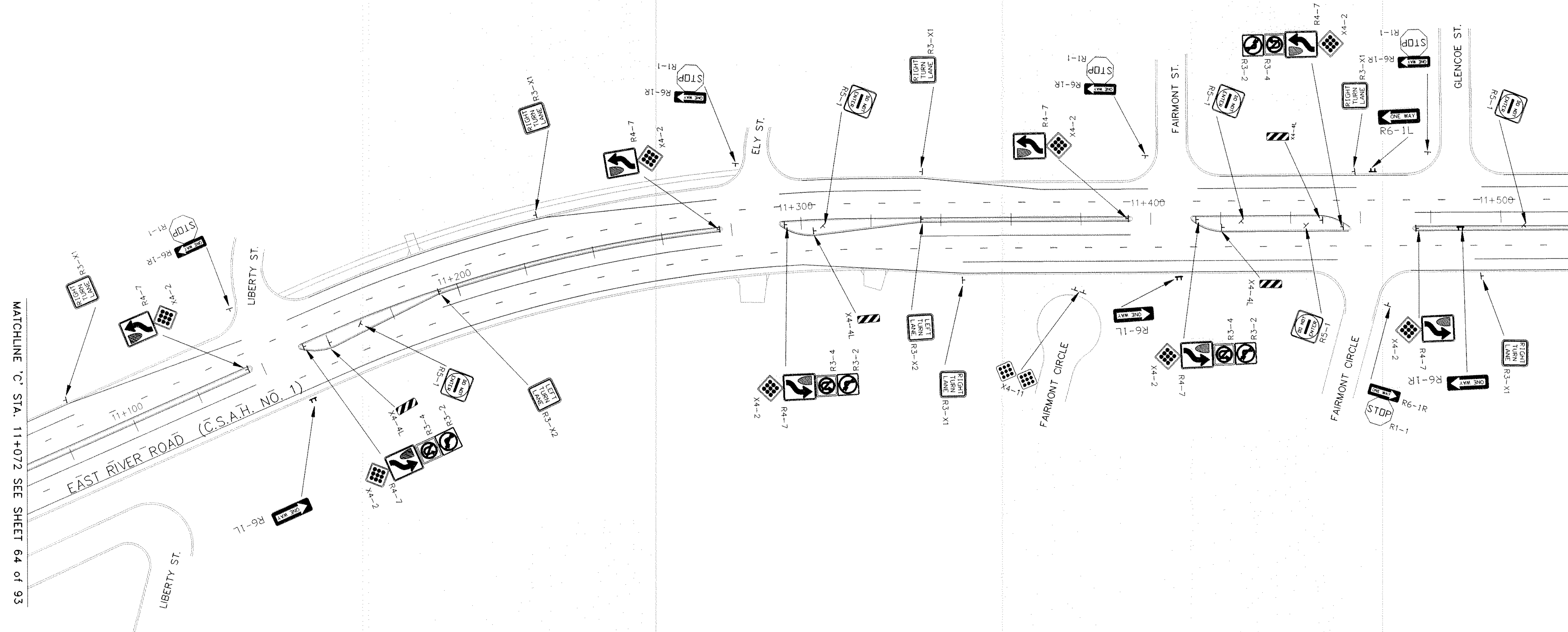

NOTES:

- 1.) LOCATIONS OF 'NO PASSING ZONES' ARE APPROXIMATE. EXACT LOCATIONS WILL BE DETERMINED IN THE FIELD.
- 2.) ALL TRAFFIC CONTROL DEVICES SHALL CONFORM THE MOST RECENT EDITION OF THE MINNESOTA MANUAL ON UNIFORM TRAFFIC CONTROL DEVICES, INCLUDING THE FIELD MANUAL DATED JANUARY 1998.

NO	DATE	BY	CKD	APPR	REVISION

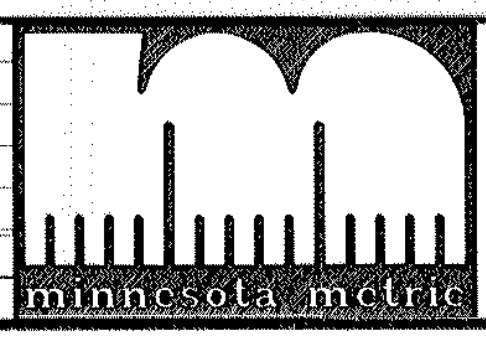

I HEREBY CERTIFY THAT THIS PLAN WAS PREPARED BY ME OR UNDER MY DIRECT SUPERVISION AND THAT I AM A DULY REGISTERED PROFESSIONAL ENGINEER UNDER THE LAWS OF THE STATE OF MINNESOTA.

DATE _____ REG. NO. _____

DRAWN BY _____ DATE _____
 DESIGN BY _____ DATE _____
 CHECKED BY _____ DATE _____



ANOKA COUNTY
 HIGHWAY DEPT.

STATE PROJECT NO. 02-601-37
 STATE PROJECT NO. 127-020-20
 STATE AID PROJECT NO. 114-020-18
 COUNTY PROJECT NO. _____

SIGNING /
 STRIPING DETAILS

Sheet 65 of 93 Sheets

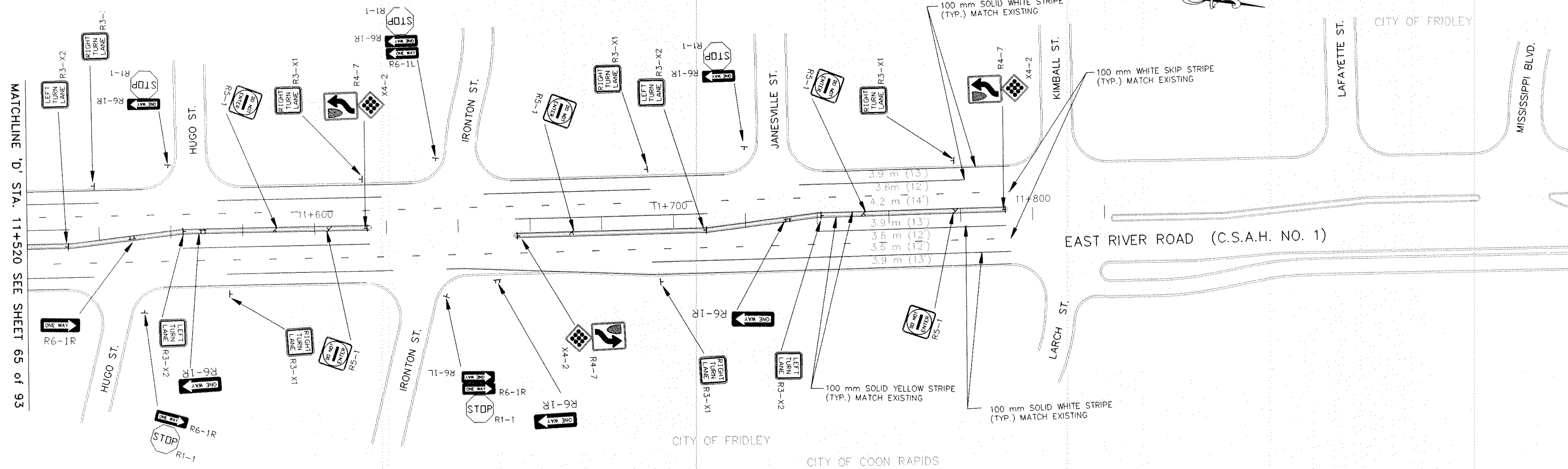

MATCHLINE 'D' STA. 11+520 SEE SHEET 65 of 93

NOTES:

- 1.) LOCATIONS OF 'NO PASSING ZONES' ARE APPROXIMATE. EXACT LOCATIONS WILL BE DETERMINED IN THE FIELD.
- 2.) ALL TRAFFIC CONTROL DEVICES SHALL CONFORM THE MOST RECENT EDITION OF THE MINNESOTA MANUAL ON UNIFORM TRAFFIC CONTROL DEVICES, INCLUDING THE FIELD MANUAL DATED JANUARY 1998.

NO	DATE	BY	CKD	APPR	REVISION

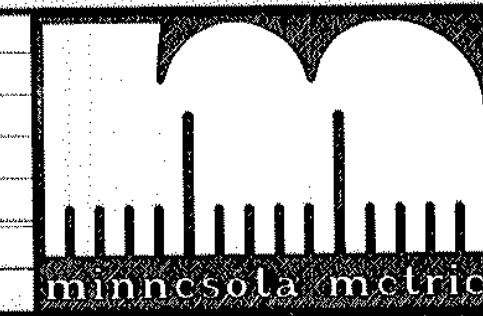

I HEREBY CERTIFY THAT THIS PLAN WAS PREPARED BY ME OR UNDER MY DIRECT SUPERVISION AND THAT I AM A DULY REGISTERED PROFESSIONAL ENGINEER UNDER THE LAWS OF THE STATE OF MINNESOTA.

DATE _____ REG. NO. _____

DRAWN BY _____ DATE _____
 DESIGN BY _____ DATE _____
 CHECKED BY _____ DATE _____

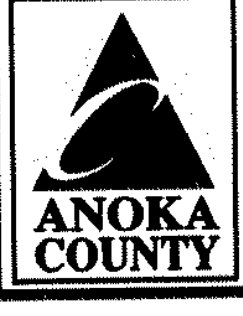

ANOKA COUNTY
HIGHWAY DEPT.

STATE PROJECT NO. 02-601-37
 STATE PROJECT NO. 127-020-20
 STATE AID PROJECT NO. 114-020-18
 COUNTY PROJECT NO. _____

SIGNING /
STRIPING DETAILS

Sheet 66 of 93 Sheets

M. U. T. C. D. CODE	SIZE	PANEL AREA		INSERT	No. of ISLAND MOUNT INSTALL			MOUNTING HEIGHT		M. U. T. C. D. CODE	SIZE	PANEL AREA		INSERT	No. of ISLAND MOUNT INSTALL			MOUNTING HEIGHT	
		FT. ²	m ²		No. GROUND POST MOUNT INSTALL	No. POST	FT.	m	FT. ²			m ²	No. GROUND POST MOUNT INSTALL		No. POST	FT.	m		
R1-1	30" x 30"	6.25	.581	STOP	0	17	1	7.0'	2.13	W3-3	36" x 36"	9.00	.836	Vertical Traffic Signal	0	2	2	7.0'	2.13
R1-2	36" x 36" x 36"	3.90	.362	YIELD	0	3	1	7.0'	2.13	W12-1	24" x 24"	4.00	.372	Left Turn Arrow	3	0	1	4.0'	1.22
R2-1	36" x 48"	12.00	1.115	SPEED LIMIT 40	0	1	2	7.0'	2.13	X4-2	18" x 18"			Flashed Yellow Diamond	22	0	(5)		
R2-1	36" x 48"	12.00	1.115	SPEED LIMIT 45	0	4	2	7.0'	2.13	X4-11	18" x 18"			Flashed Yellow Diamond	0	4	1	4.0'	1.22
R3-2	24" x 24"	4.00	.372	No Left Turn	6	0	(1)			X4-4L	12" x 36"			Vertical Bar	7	0	1	4.0'	1.22
R3-4	24" x 24"	4.00	.372	No Right Turn	8	0	(1)			X4-4R	12" x 36"			Vertical Bar	3	0	1	4.0'	1.22
R3-X1	30" x 30"	6.25	.581	RIGHT TURN LANE	0	21	1	7.0'	2.13										
R3-X2	30" x 30"	6.25	.581	LEFT TURN LANE	13	0	1	7.0'	2.13										
R4-7	24" x 30"	5.00	.465	Right Turn Arrow	22	0	1	7.0'	2.13										
R5-1	30" x 30"	6.25	.581	DO NOT ENTER	22	0	1	7.0'	2.13										
R6-1R	36" x 12"	3.00	.279	ONE WAY (Right)	17	0	(2)												
R6-1L	36" x 12"	3.00	.279	ONE WAY (Left)	4	0	(4)												
R6-1R	48" x 18"	6.00	.557	ONE WAY (Right)	8	1	2	7.0'	2.13										
R6-1L	48" x 18"	6.00	.557	ONE WAY (Left)	0	5	2	7.0'	2.13										

- *1. MOUNTED BACK TO BACK WITH R4-7
- *2. MOUNTED ABOVE R1-1 (STOP)
- *3. MOUNTED ON SIGNAL POLE
- *4. MOUNTED BACK TO BACK WITH R6-1R ABOVE R1-1
- *5. MOUNTED BELOW R4-7

NOTES:

- 1.) LOCATIONS OF 'NO PASSING ZONES' ARE APPROXIMATE. EXACT LOCATIONS WILL BE DETERMINED IN THE FIELD.
- 2.) ALL TRAFFIC CONTROL DEVICES SHALL CONFORM THE MOST RECENT EDITION OF THE MINNESOTA MANUAL ON UNIFORM TRAFFIC CONTROL DEVICES, INCLUDING THE FIELD MANUAL DATED JANUARY 1998.

FF

NO	DATE	BY	CKD	APPR	REVISION

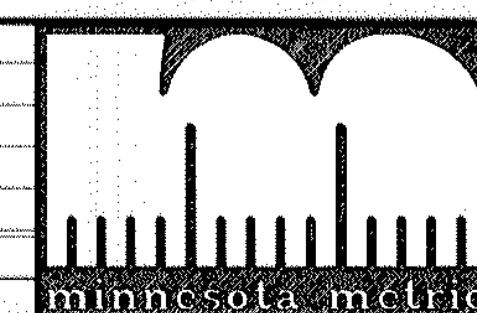

I HEREBY CERTIFY THAT THIS PLAN WAS PREPARED BY ME OR UNDER MY DIRECT SUPERVISION AND THAT I AM A DULY REGISTERED PROFESSIONAL ENGINEER UNDER THE LAWS OF THE STATE OF MINNESOTA.

DATE _____ REG. NO. _____

DRAWN BY _____ DATE _____
 DESIGN BY _____ DATE _____
 CHECKED BY _____ DATE _____

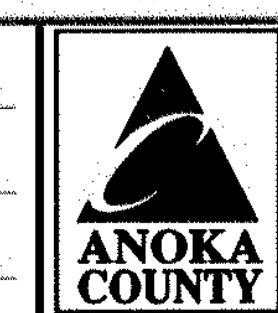

ANOKA COUNTY
HIGHWAY DEPT.

STATE PROJECT NO. 02-601-37
 STATE PROJECT NO. 127-020-20
 STATE AID PROJECT NO. 114-020-18
 COUNTY PROJECT NO. _____

SIGNING / STRIPING DETAILS
 Sheet 67 of 93 Sheets

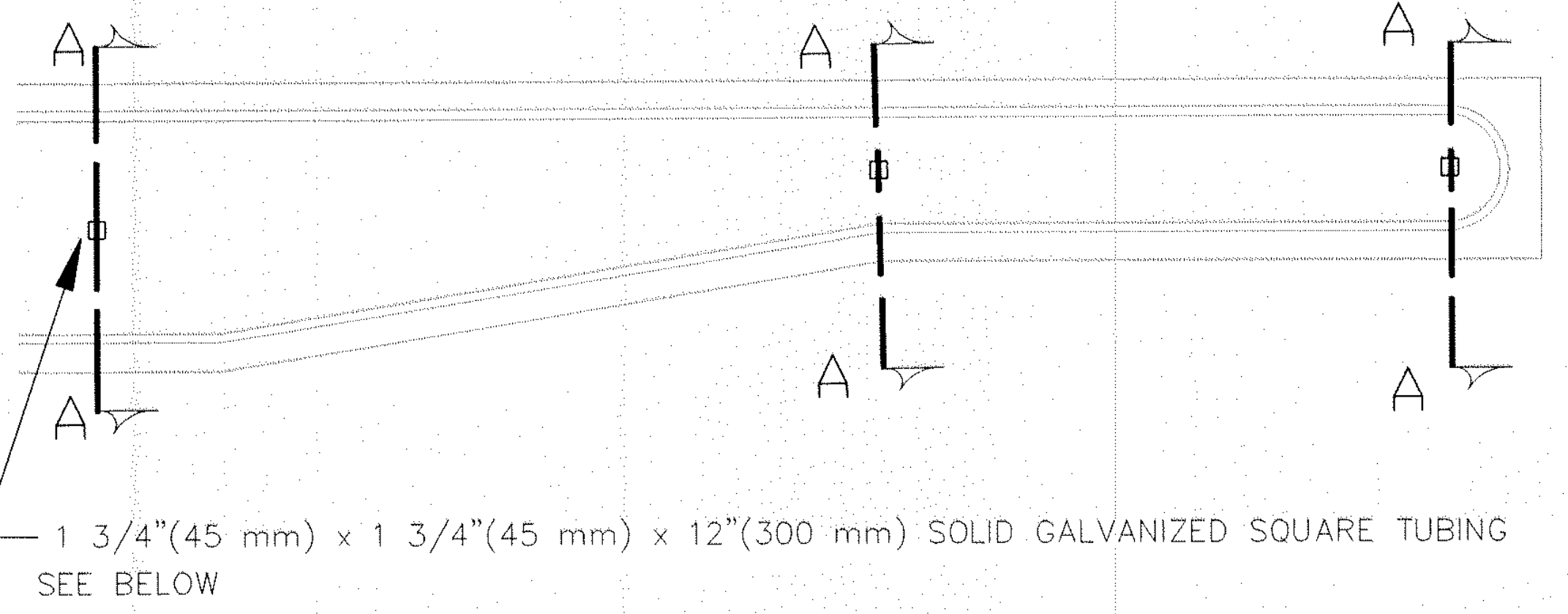
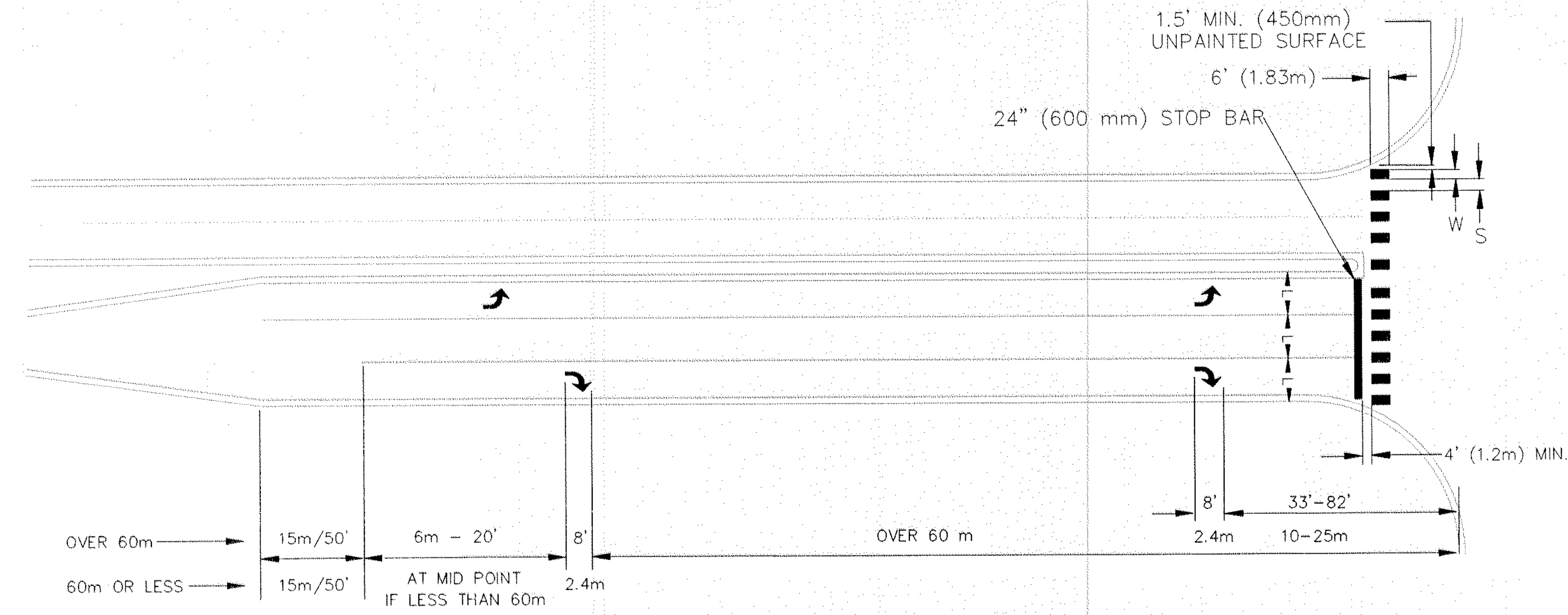

(L)	(W)	(S)
WIDTH OF INSIDE LANE	WIDTH OF PAINTED AREAS	WIDTH OF SPACE
9'	2.0'	2.5'
10'	2.5'	2.5'
11'	2.5'	3.0'
12'	3.0'	3.0'
13'	3.0'	3.5'

- NOTES: CROSSWALKS:
- 1.) PAINTED AREAS ARE TO BE CENTERED ON CENTER AND LANE LINES, EVEN IF INTERSECTION IS NOT ALIGNED.
 - 2.) LOCATION OF ZEBRA CROSSWALKS AND STOP BARS, SIGNAL LOOPS AND PED RAMPS ARE APPROXIMATE. FINAL LOCATIONS ARE TO BE DETERMINED AND FIELD VERIFIED DURING CONSTRUCTION BY THE FIELD ENGR.
 - 3.) ZEBRA CROSSWALKS ARE TO BE PARALLEL TO THE DRIVING LANE OR LANES, EVEN IF THE STREET IS ON AN ANGLE TO THE INTERSECTION.
 - 4.) A MIN. OF 1.5' (450mm) CLEAR DISTANCE MUST BE LEFT ADJACENT TO THE CURB. IF LAST PAINTED AREA FALLS INTO THIS AREA, IT MUST BE OMITTED.
 - 5.) ON TWO LANE STREETS, USE SPACING SHOWN FOR AN 11' (3.3m) NSIDE LANE.

(L)	(W)	(S)
WIDTH OF INSIDE LANE	WIDTH OF PAINTED AREAS	WIDTH OF SPACE
2.7m	600mm	750mm
3.0m	750mm	750mm
3.3m	750mm	900mm
3.6m	900mm	900mm
4.0m	900mm	1100mm

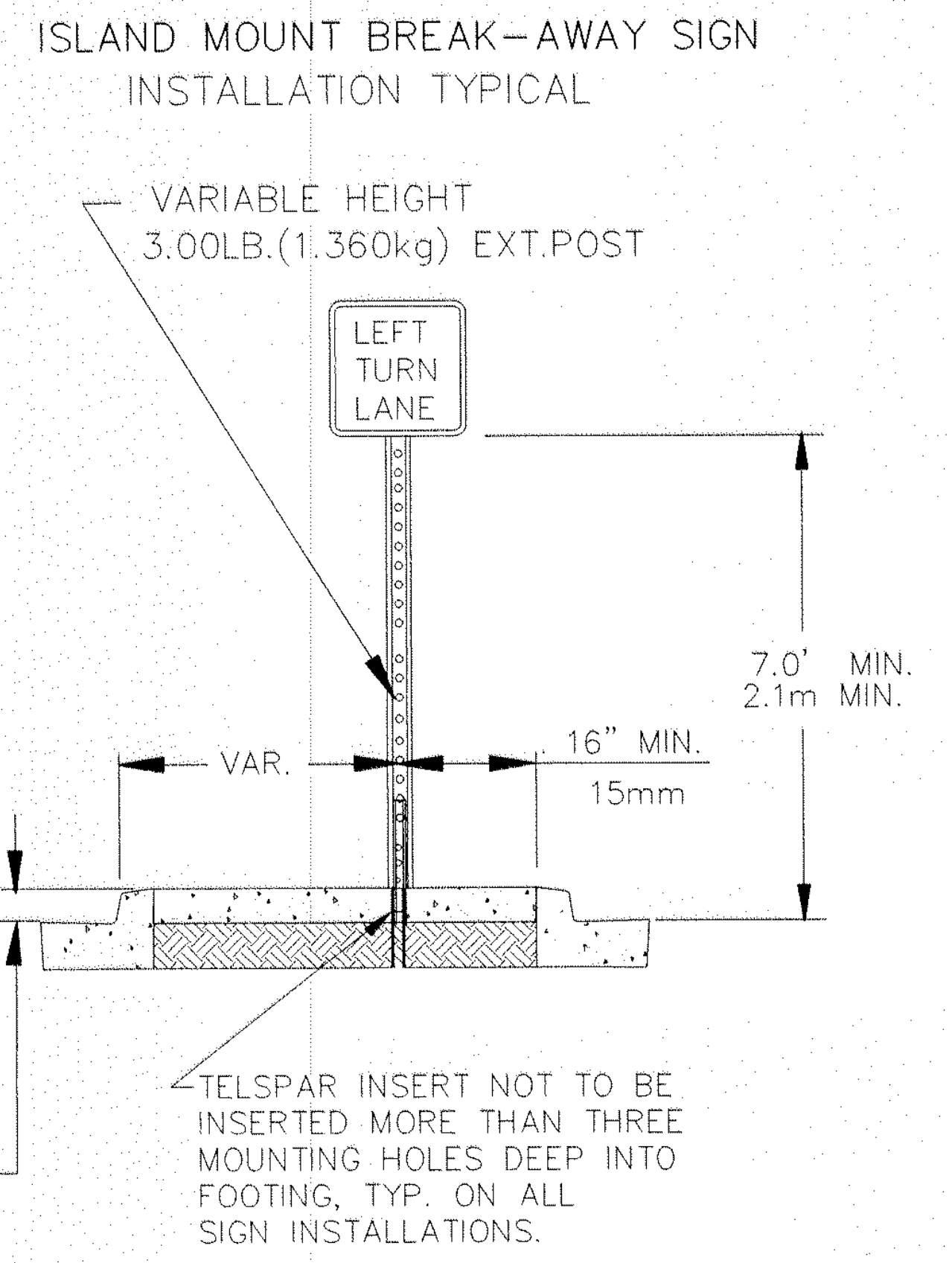
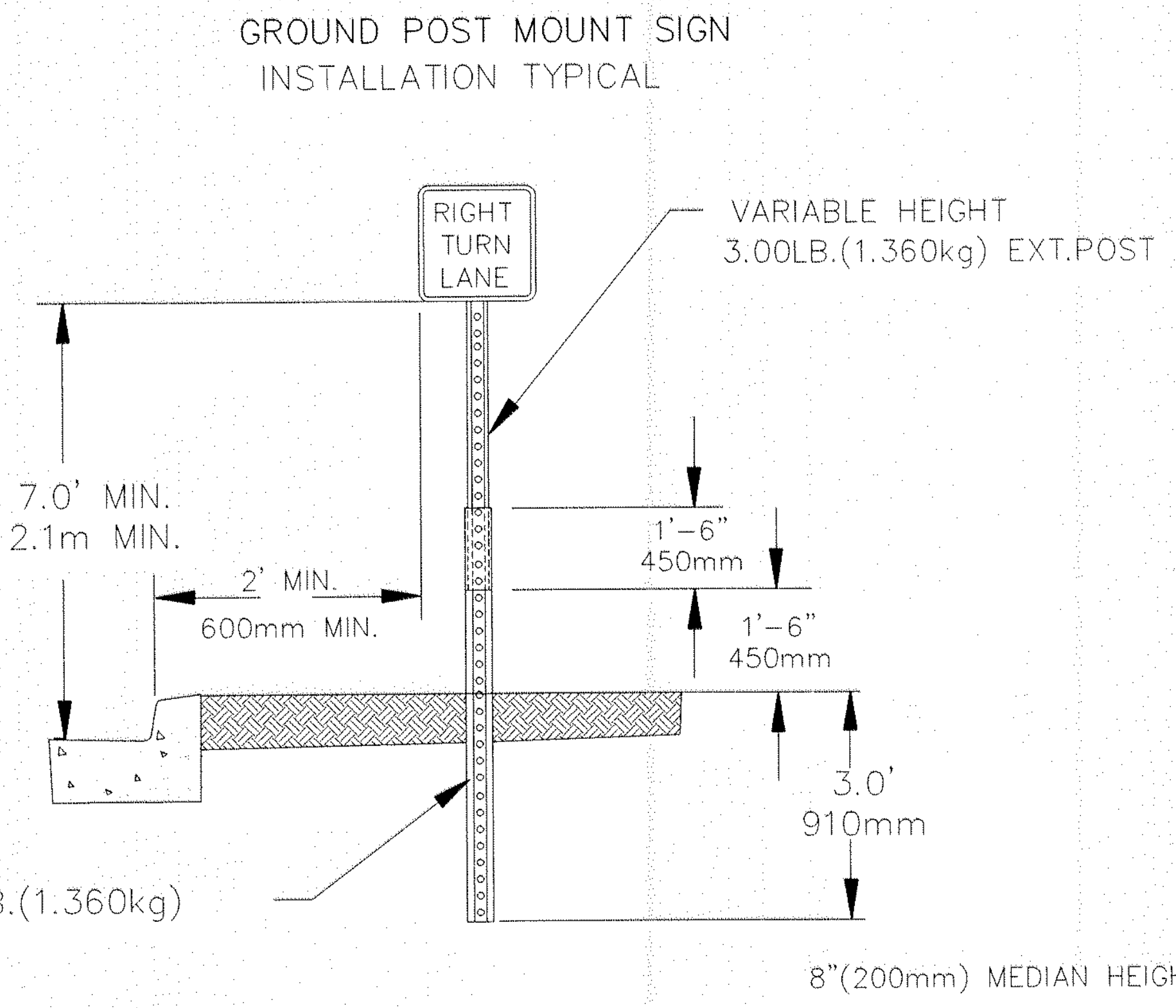
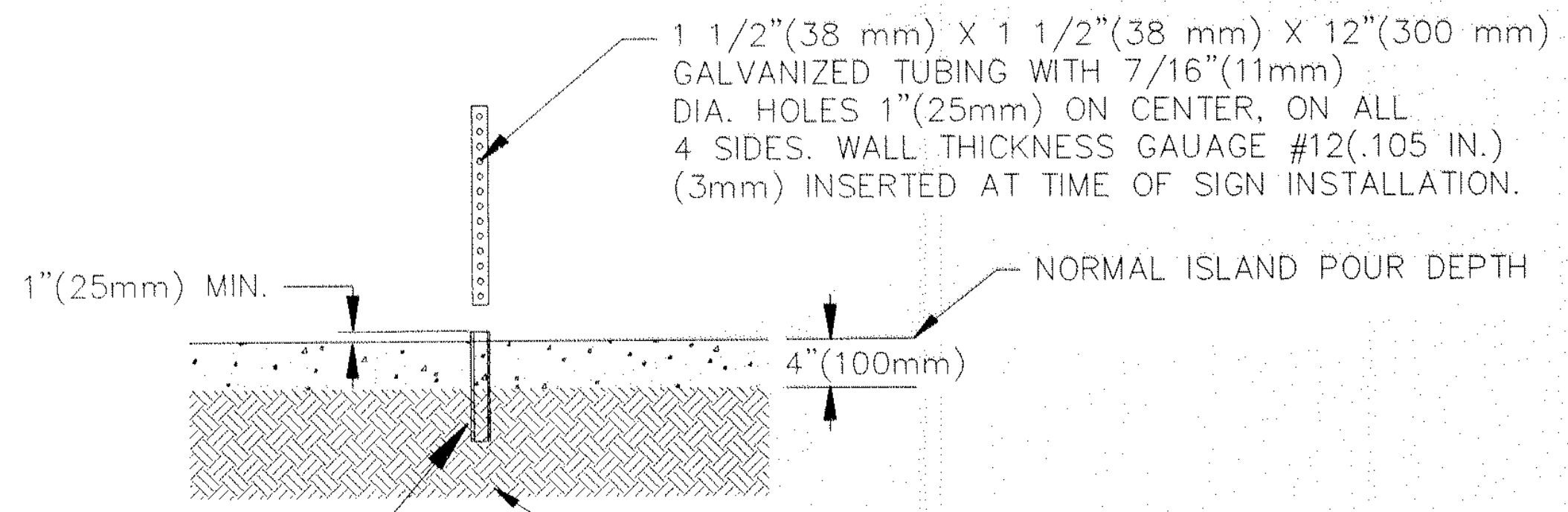

INSTALL 1 3/4\"(45MM) X 1 3/4\"(45MM) X 12\"(300 mm) SOLID WALL GALVANIZED SQUARE TUBING BEFORE CONCRETE POUR. HAMMER INTO GROUND SO THAT 1\" (25mm) OF TUBE IS ABOVE TOP OF CURB. RE-PLUMB AT TIME OF POUR.

NO	DATE	BY	CKD	APPR	REVISION

I HEREBY CERTIFY THAT THIS PLAN WAS PREPARED BY ME OR UNDER MY DIRECT SUPERVISION AND THAT I AM A DULY REGISTERED PROFESSIONAL ENGINEER UNDER THE LAWS OF THE STATE OF MINNESOTA.

DATE _____ REG. NO. _____

DRAWN BY _____ DATE _____
 DESIGN BY _____ DATE _____
 CHECKED BY _____ DATE _____

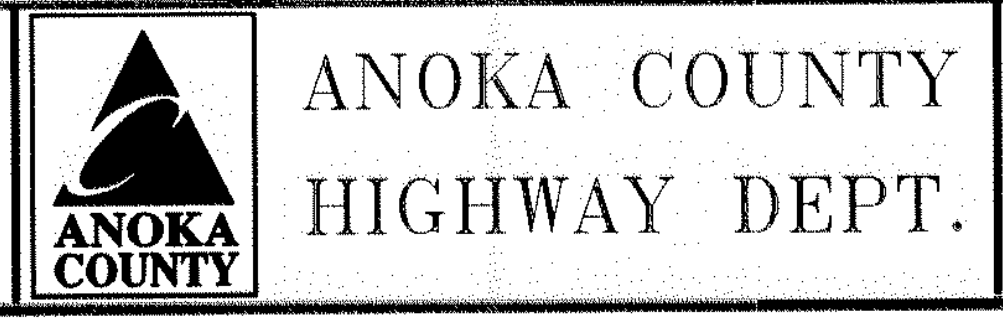

STATE PROJECT NO. 02-601-37
 STATE PROJECT NO. 127-020-20
 STATE AID PROJECT NO. 114-020-18
 COUNTY PROJECT NO. _____

SIGNING / STRIPING DETAILS
 Sheet 68 of 93 Sheets

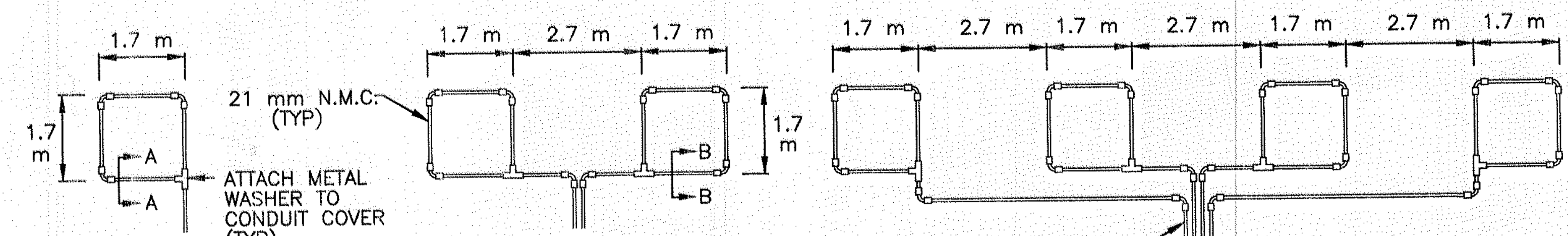

21 mm N.M.C. (TYP)
ATTACH METAL WASHER TO CONDUIT COVER (TYP)

LOOP RETURN CONDUITS MAY BE PLACED IN COMMON TRENCH (TYP)

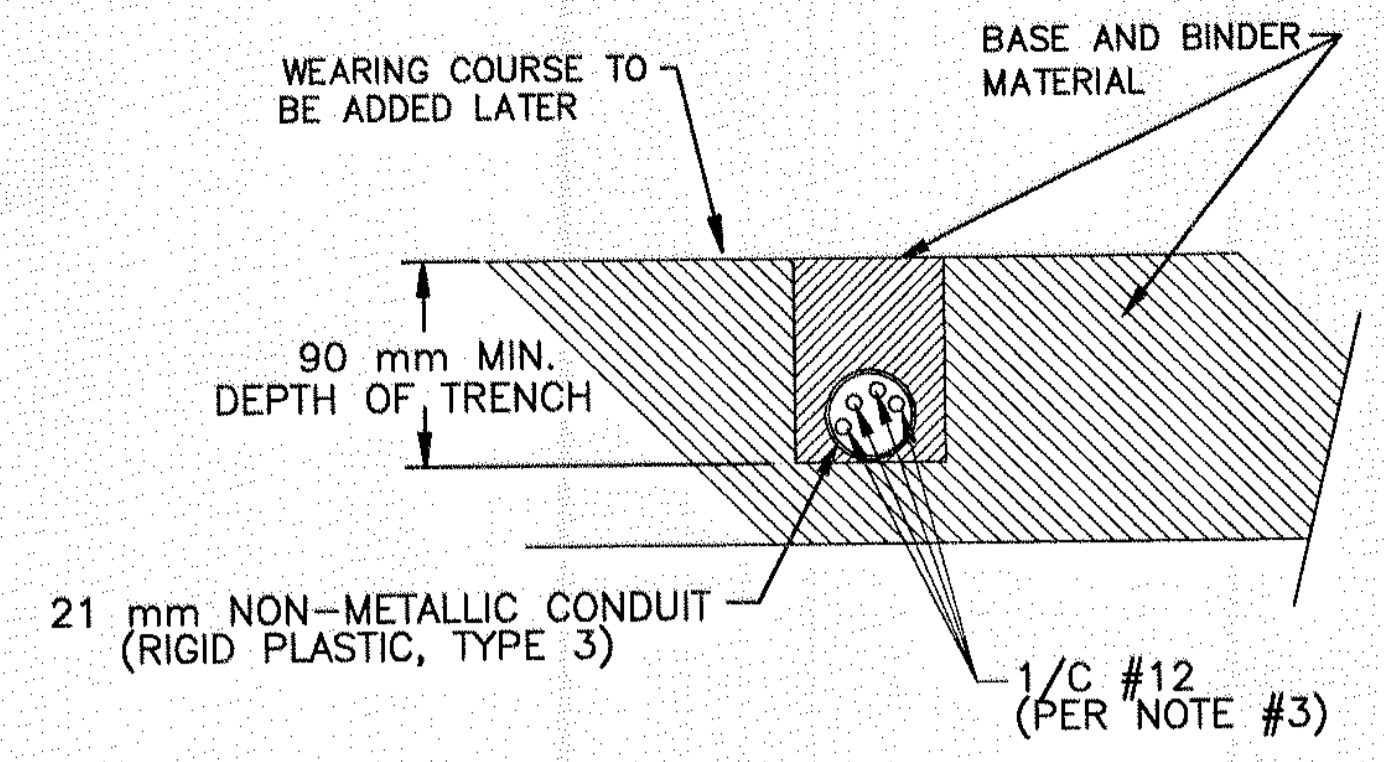

SECTION A-A

DETAIL FOR LOOP INSTALLATION IN NEW ROADWAY

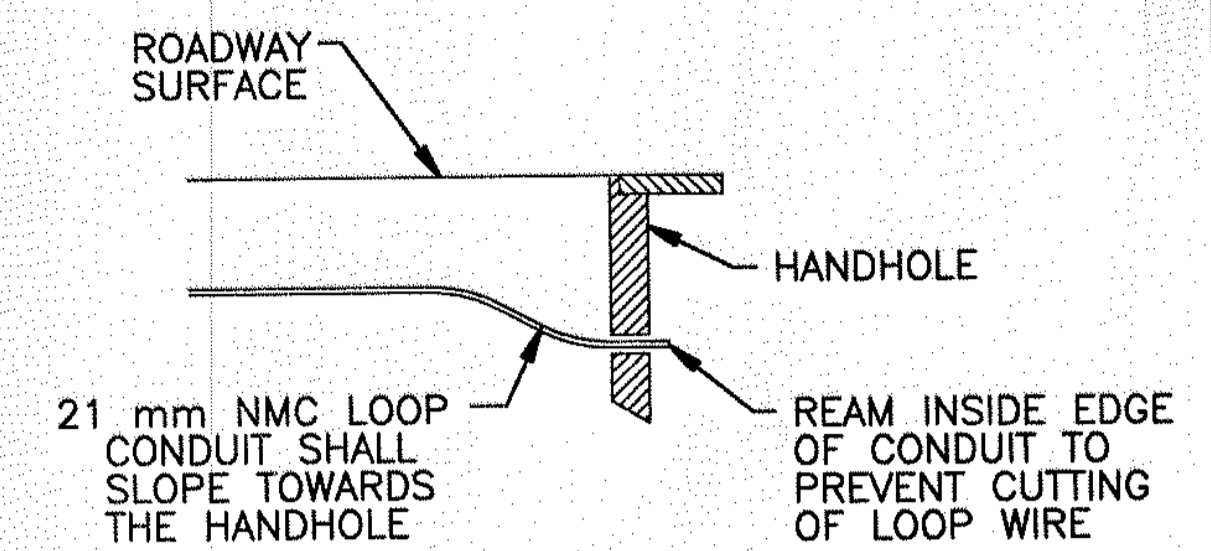

DRAINAGE DETAIL

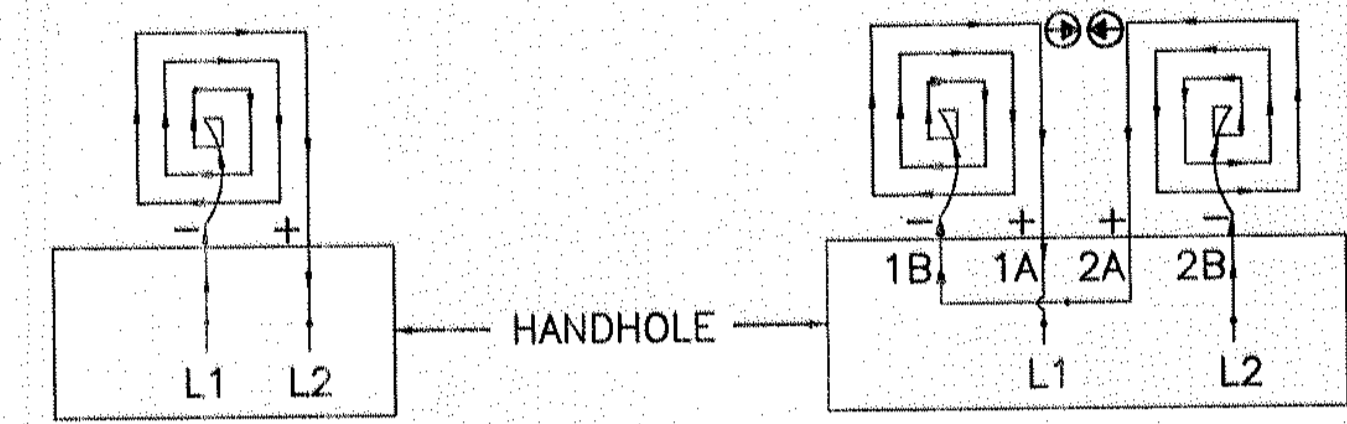

LOOP DETECTOR DETAIL A
(LOOP PHASING FOR SINGLE CONNECTION)

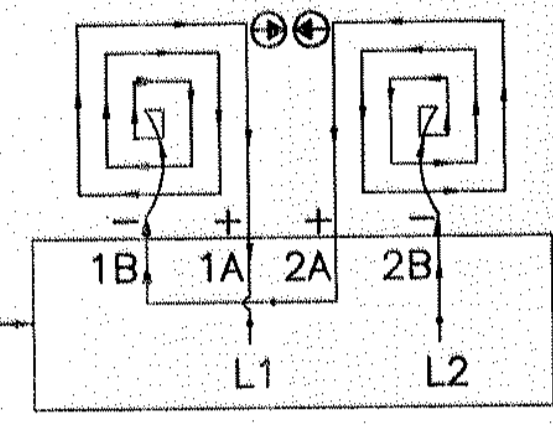

LOOP CONNECTIONS SHALL BE LABELED AND SPLICED IN THE HANDHOLE AS FOLLOWS:

- L1 TO 1A
- 1B TO 2A
- 2B TO L2

LOOP DETECTOR DETAIL B
(LOOP PHASING FOR SERIES CONNECTION)

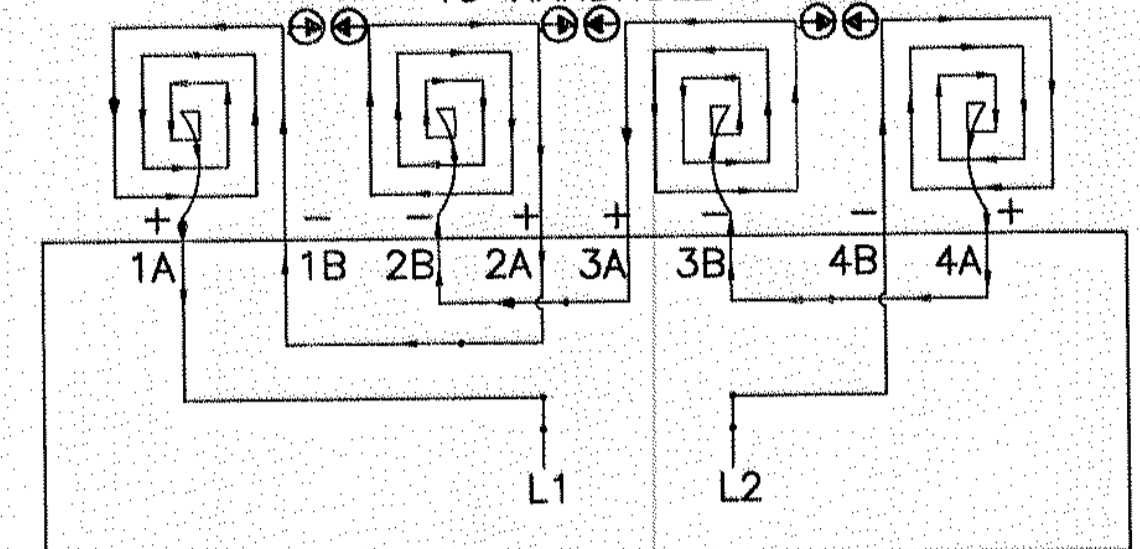

LOOP CONNECTIONS SHALL BE LABELED AND SPLICED IN THE HANDHOLE AS FOLLOWS:

- L1 TO 1A
- 1B TO 2A
- 2B TO 3A
- 3B TO 4A
- 4B TO L2

SPLICE CONTROL CABLE TO L1 & L2 IN HANDHOLE. ALL CONDUCTORS SHALL BE TAGGED IN HANDHOLE (1A, 1B, ECT)

LOOP DETECTOR DETAIL C
(LOOP PHASING FOR SERIES CONNECTION)

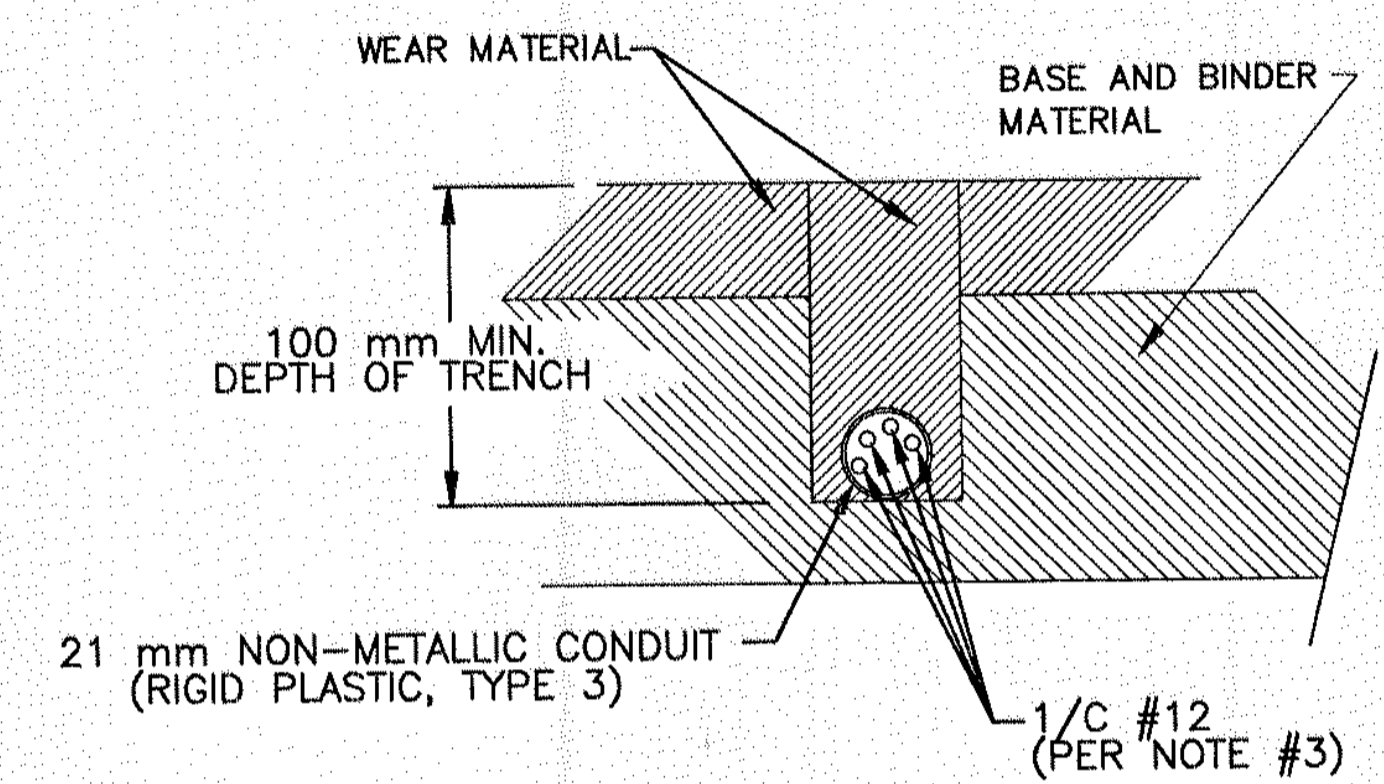

SECTION B-B

DETAIL FOR LOOP INSTALLATION IN EXISTING ROADWAY

- LOOP DETECTOR WIRING**
- 1) ALL CORNERS SHALL BE 90° CONDUIT BENDS.
 - 2) CONNECT WIRES IN HANDHOLES USING SPLICE KIT METHOD DESCRIBED IN THE SPECIAL PROVISIONS.
 - 3) LOOP DETECTOR WIRES SHALL BE #12 AWG CROSSED LINKED POLYETHYLENE (XLP). SEE SPECIAL PROVISIONS.
 - 4) LOOP LEAD IN WIRES SHALL BE TWISTED A MIN. OF (5) TURNS PER 0.3 METER (1 FOOT) THROUGH THE CONDUIT TO THE HANDHOLE.
 - 5) NMC DESIGNATES NON-METALLIC CONDUIT (SPEC. 3803)
 - 6) LOOPS 1.7 m x 1.7 m THRU 1.7 m x 4.3 m SHALL HAVE (4) TURNS.
 - 7) LOOPS 1.7 m x 4.6 m AND LARGER SHALL HAVE (2) TURNS.

STANDARD PLATES	
THESE STANDARD PLATES AS APPROVED BY FHWA SHALL APPLY:	
PLATE NO.	DESCRIPTION
* M8110 D	TRAFFIC SIGNAL BRACKETING - POLE MOUNTED
* M8111 C	TRAFFIC SIGNAL BRACKETING - PEDESTAL MOUNTED
* M8112 C	PEDESTAL FOUNDATION
M8113 C	MAGNETIC VEHICLE DETECTOR INSTALLATION
* M8114 A	PVC HANDHOLE/PULLBOX
M8115 D	PEDESTRIAN PUSH BUTTON INSTALLATION
* M8118 C	SERVICE EQUIPMENT AND POLE-TRAFFIC CONTROL SIGNALS
* M8119 C	GROUND MOUNTED CABINET FOUNDATION
* M8120 K	PA85 POLE FOUNDATION
* M8121 D	TRANSFORMER BASE AND POLE BASE PLATE
* M8122 C	PEDESTAL AND PEDESTAL BASE
* M8123 D	POLE AND MAST ARM
* M8124 E	MAST ARM SIGNAL HEAD MOUNTS
* M8126 F	PA90 AND PA100 POLE FOUNDATION

* - APPLIES TO THIS PROJECT

LEGEND OF SYMBOLS

CONTROLLER AND SERVICE EQUIP. NO's	(A)
SIGNAL BASE NO.	(B)
SIGNAL FACE NO.	(C)
LUMINAIRE NO.	(D)
CONTROLLER AND CABINET	(E)
CONTROLLER AND CABINET - IN PLACE	(F)
HANDHOLE - IN PLACE	(G)
RIGID STEEL CONDUIT (RSC)	(H)
RIGID STEEL CONDUIT (RSC) - IN PLACE	(I)
SIGNAL FACE WITH BACKGROUND SHIELD	(J)
SIGNAL FACE W/O BACKGROUND SHIELD	(K)
SIGNAL FACE - IN PLACE	(L)
PEDESTRIAN INDICATORS	(M)
PEDESTRIAN INDICATORS - IN PLACE	(N)
PEDESTRIAN PUSH BUTTONS ON PEDESTAL OR POLE	(O)
PEDESTRIAN PUSH BUTTON STATION	(P)
TRAFFIC SIGNAL PEDESTAL	(Q)
TRAFFIC SIGNAL PEDESTAL - INPLACE	(R)
TRAFFIC SIGNAL POLE AND MAST ARM	(S)
TRAFFIC SIGNAL POLE AND MAST ARM - IN PLACE	(T)
STREET LIGHT POLE AND LUMINAIRE	(U)
STREET LIGHT POLE AND LUMINAIRE - IN PLACE	(V)
MAST ARM AND LUMINAIRE	(W)
MAST ARM AND LUMINAIRE - INPLACE	(X)
WOOD POLE	(Y)
WOOD POLE - IN PLACE	(Z)
SOURCE OF POWER	(AA)
RAILROAD SIGNAL - IN PLACE	(AB)
RIGHT OF WAY LINE	(AC)
CENTERLINE	(AD)
EDGE OF ROADWAY	(AE)
SHOULDERLINE	(AF)
CURB LINE	(AG)
STOP BAR	(AH)

ABBREVIATIONS

3-1(EG)	SIGNAL HEAD PHASE "3" - NO "1"	P2-1(EG)	PEDESTRIAN INDICATION PHASE "2" - NO. "1"
BR. GR.	BARE GROUND	PB	PUSH BUTTON
CH. SW.	CHECK SWITCH	PB2-1(EG)	PUSH BUTTON PHASE "2" - NO. "1"
CLR	CLEAR	PEC	PHOTOELECTRIC CELL
D2-1(EG)	DETECTOR PHASE "2" - NO. "1"	PED	PEDESTRIAN
DWK	DON'T WALK	R	RED
EQG	EQUIPMENT GROUND	R&S	REMOVE AND SALVAGE
EVP	EMERGENCY VEHICLE PRE-EMPTION	RLTA	RED LEFT TURN ARROW
F&I	FURNISH AND INSTALL	RRTA	RED RIGHT TURN ARROW
FL	FLASH/FLASHING	RSC	RIGID STEEL CONDUIT
G	GREEN	SOP	SOURCE OF POWER
GLTA	GREEN LEFT TURN ARROW	SPR	SPARE
GRN	GREEN	ST. LHT	STREET LIGHT
GR. R	GROUND ROD	STA	STATION
GRTA	GREEN RIGHT TURN ARROW	SW	SWITCH
GTHA	GREEN THRU ARROW	SWD	SWITCHED
HH	HANDHOLE	S&R	SALVAGE AND REINSTALL
HPS	HIGH PRESSURE SODIUM	TDW	TELEPHONE DROP WIRE
JB	JUNCTION BOX	WLK	WALK
LUM	LUMINAIRE	YEL	YELLOW
NEU	NEUTRAL	YLTA	YELLOW LEFT TURN ARROW
NMC	NONMETALLIC CONDUIT	YRTA	YELLOW RIGHT TURN ARROW
		YTHA	YELLOW THRU ARROW

CONDUCTOR COLOR CODE

R	RED
O	ORANGE
BL	BLUE
WH	WHITE
R/BLK	RED WITH BLACK TRACER
O/BLK	ORANGE WITH BLACK TRACER
BL/BLK	BLUE WITH BLACK TRACER
WH/BLK	WHITE WITH BLACK TRACER
BLK	BLACK
BLK/WH	BLACK WITH WHITE TRACER
G/BLK	GREEN WITH BLACK TRACER
G	GREEN

NO.	BY	DATE	REVISIONS	ITEM	DESIGN	CHECKED

I hereby certify that this plan was prepared by me or under my direct supervision and that I am a duly Registered Professional Engineer under the laws of the state of Minnesota.
Date: 3/10/98 Reg. No. 22457



ANOKA COUNTY, MINNESOTA
CITY OF FRIDLEY
S.P. 02-601-37
S.P. 127-020-20

TRAFFIC SIGNAL SYSTEMS
DETAILS & STANDARD PLATES
EAST RIVER ROAD (CSAH 1) AT 77TH WAY NE/
79TH WAY NE

FILE NO.	ANOKC9708	69
DATE		93

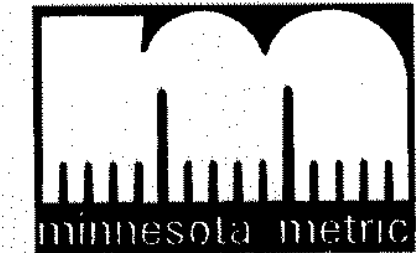

SIGNAL SERVICE CABINET

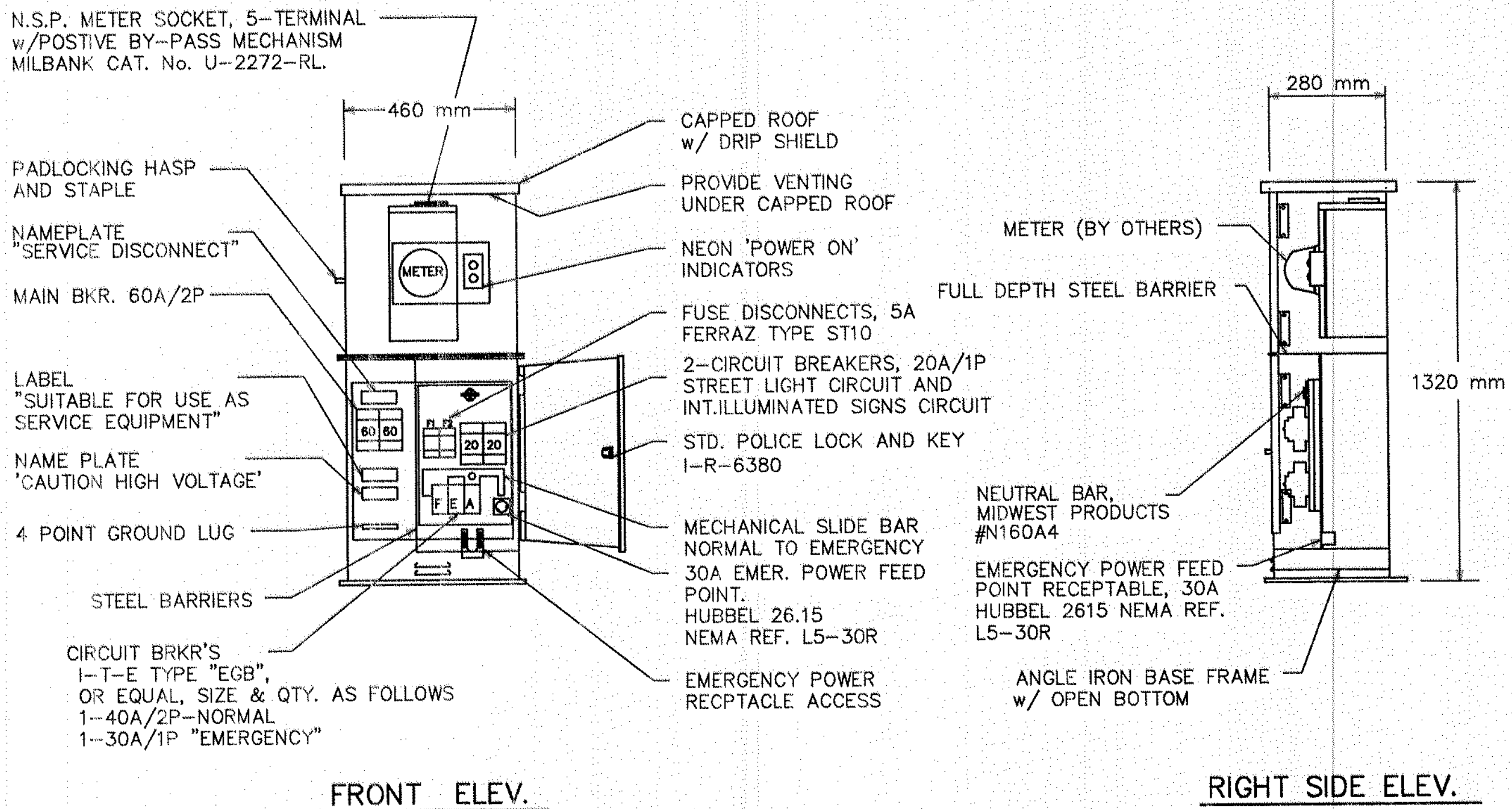

CONSTRUCTION NOTES

ENCLOSURE SHALL BE FABRICATED FROM #12 GA. ALL WELDED COLD ROLLED STEEL FOR OUTDOOR WEATHER PROOF SERVICE. DOORS TO BE GASKETED, ALL HINGES, PINS AND LOCKS TO BE OF NON CORRODING CONSTRUCTION. CABINET TO BE PRIMED INSIDE AND OUT WITH RUST INHIBITING PRIMER. FINISH PER MN/DOT #3527. ENCLOSURE SHALL BE 'UL' APPROVED

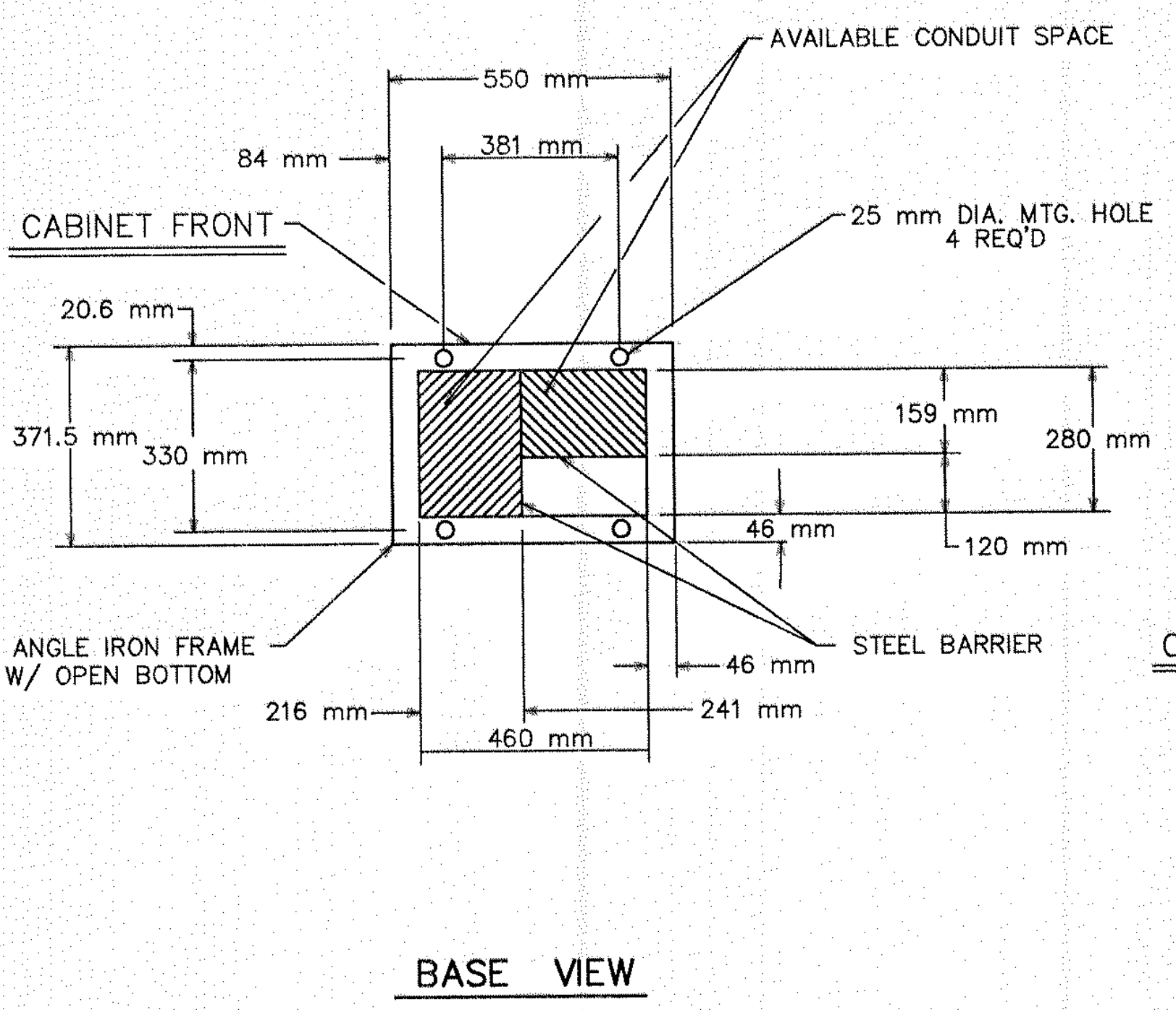

SERVICE CABINET FOUNDATION

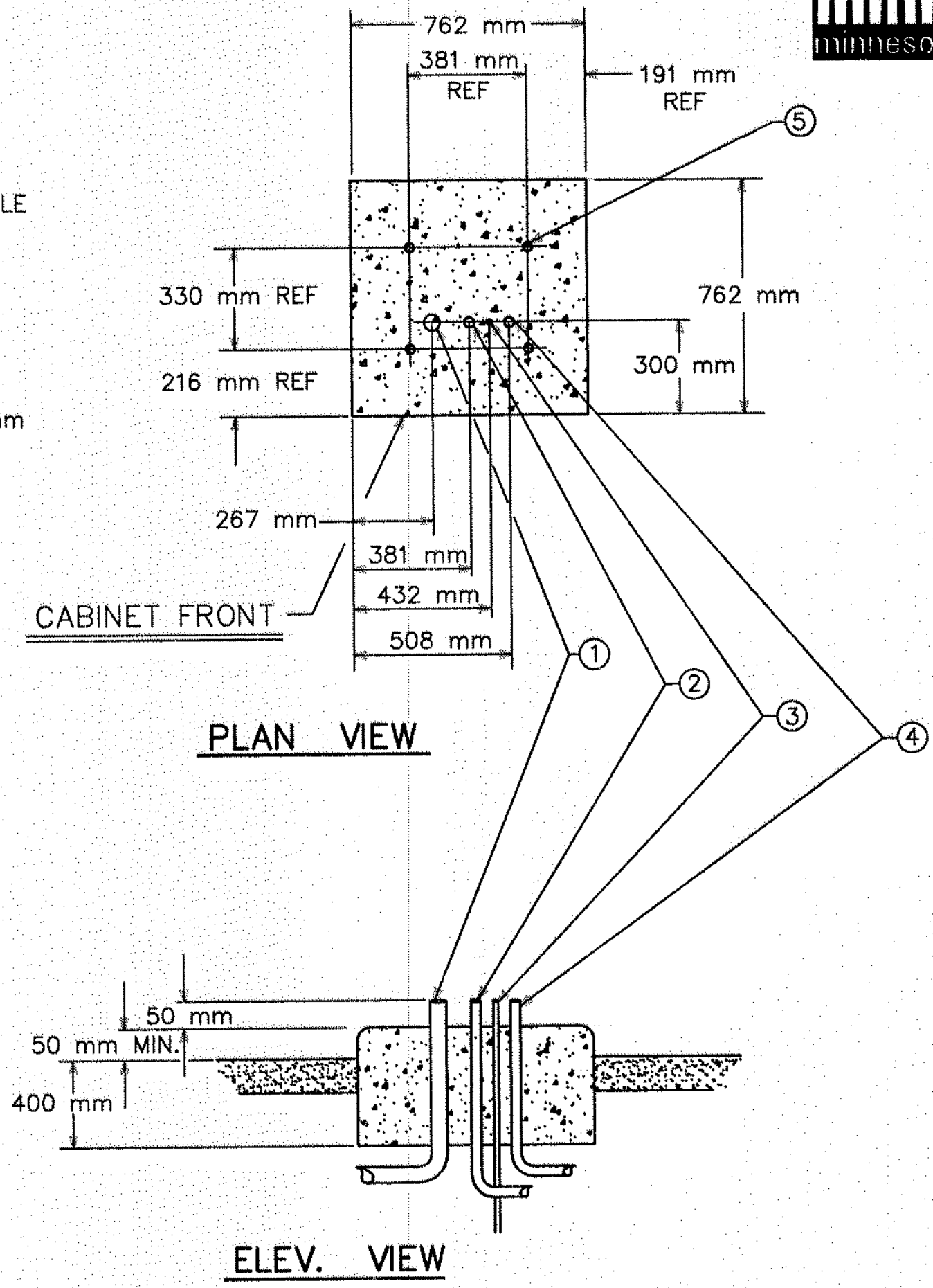

MAST ARM POLE PEDESTRIAN PUSH BUTTON DETAIL

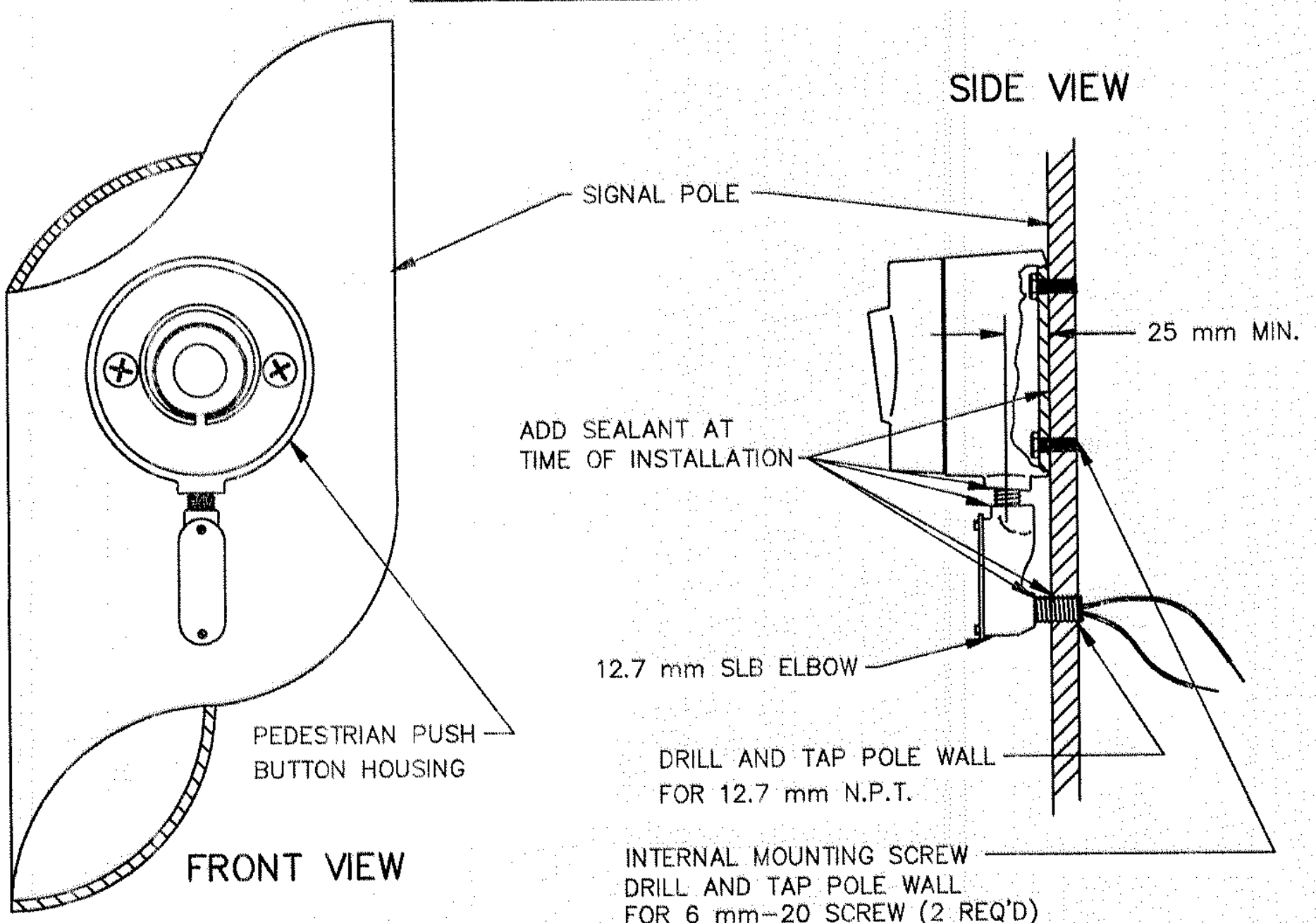

- Ⓐ 35 mm R.S.C. FOR SERVICE CONNECTION
- Ⓑ 103 mm R.S.C. TO HH
- Ⓒ 103 mm R.S.C. TO HH
- Ⓓ 78 mm R.S.C. STUBOUT, THREAD & CAP BOTH ENDS (FOR FUTURE USE).
- Ⓔ 15.8 mm DIA X 4.6 m GROUND ROD
- Ⓕ 53 mm R.S.C. STUBOUT, THREAD & CAP BOTH ENDS (FOR FUTURE USE).

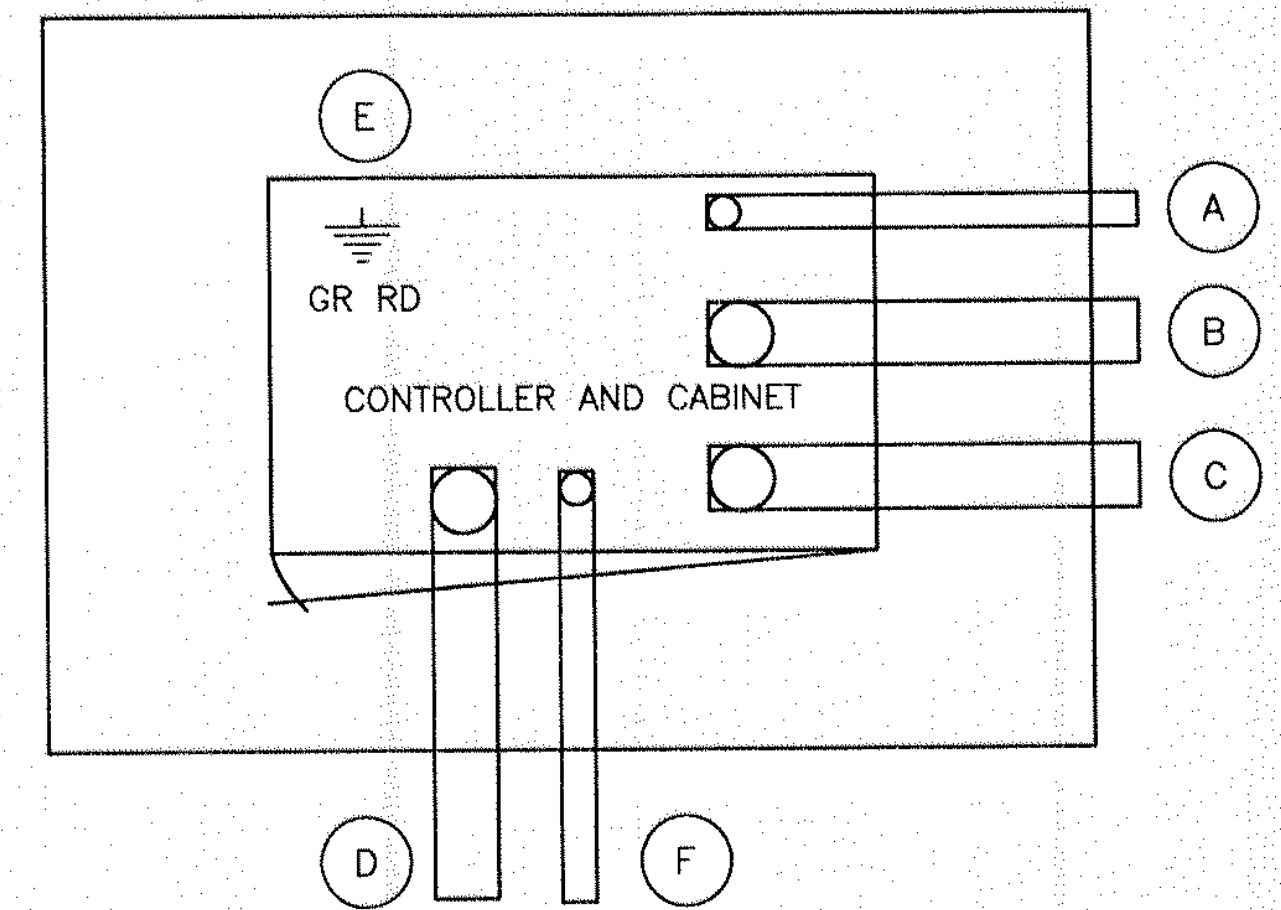

EVP DETECTOR AND LIGHT MOUNTING DETAIL ON MAST ARM

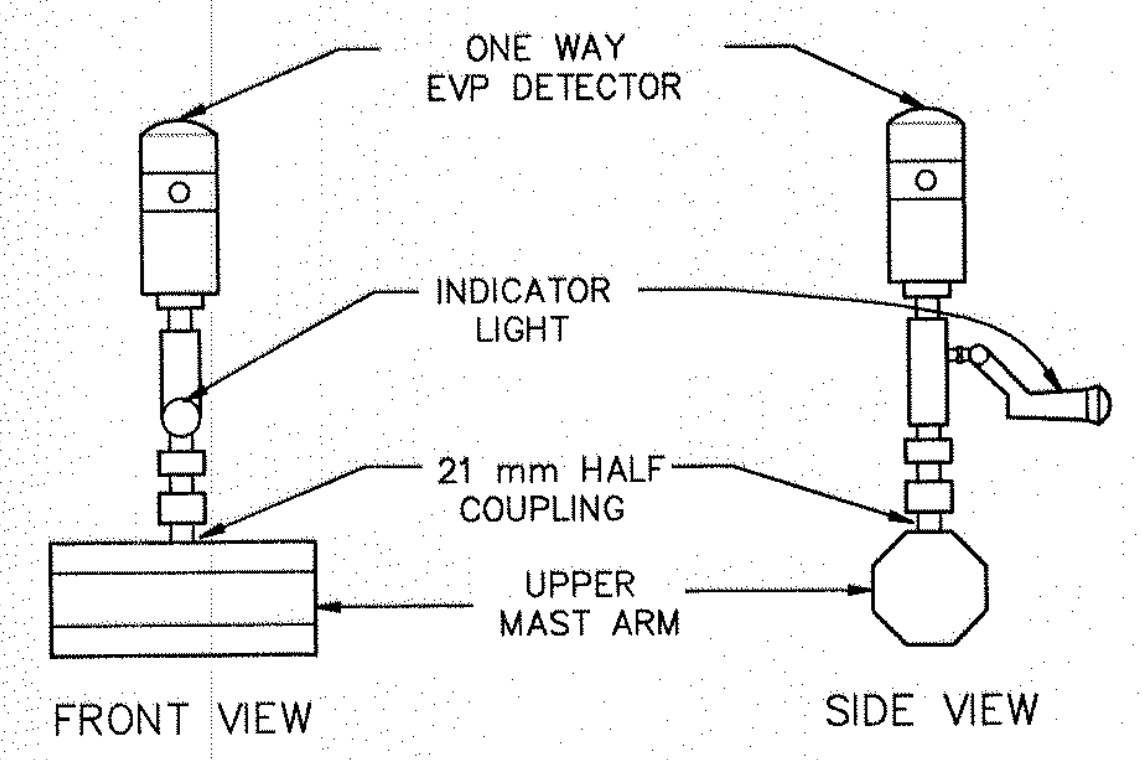

NO.	BY	DATE	REVISIONS	ITEM	DESIGN	CHECKED

I hereby certify that this plan was prepared by me or under my direct supervision and that I am a duly Registered Professional Engineer under the laws of the state of Minnesota.

Date: 3/10/98 Reg. No. 22457



ANOKA COUNTY, MINNESOTA
CITY OF FRIDLEY
 S.P. 02-601-37
 S.P. 127-020-20

TRAFFIC SIGNAL SYSTEMS
DETAILS
 EAST RIVER ROAD (CSAH 1) AT 77TH WAY NE/
 79TH WAY NE

FILE NO.	70
ANOKC9708	
DATE	
	93



TYPE "D" SIGNS - F & I									
SIGNAL SYSTEM	SIGN PANEL	SIZE (inches)	SIZE (meters)	NO. REQ.	NO. POSTS PER SIGN	POST SPACING (mm)	AREA (sq. meters) PER SIGN	POLE NO.	ø
A	D-1	120x18	3.05x0.46	1	3	1145	1.40	1	4.8 m
A	D-2	120x18	3.05x0.46	1	3	1145	1.40	3	8.5 m
A	D-3	120x18	3.05x0.46	1	3	1145	1.40	4	1.2 m
B	D-4	102x18	2.60x0.46	1	3	1145	1.20	1	8.5 m
B	D-5	120x18	3.05x0.46	1	3	1145	1.40	3	2.4 m
B	D-6	102x18	2.60x0.46	1	3	1145	1.20	4	8.5 m
B	D-7	120x18	3.05x0.46	1	3	1145	1.40	6	2.4 m
TYPE "C" SIGNS - F & I									
A	R6-1L	36x12	0.91x0.30	1	①	-	0.28	3	-
A	R6-1R	36x12	0.91x0.30	1	①	-	0.28	1	-
B	R6-1L	36x12	0.91x0.30	2	①	-	0.28	1,4	-

NOTES:

- COLOR FOR SIGNS D-1, D-2, D-4 AND D-6 SHALL BE WHITE LEGEND AND BORDER ON BLUE BACKGROUND, FULLY REFLECTORIZED.
- COLOR FOR SIGNS D-3, D-5 AND D-7 SHALL BE WHITE LEGEND AND BORDER ON GREEN BACKGROUND, FULLY REFLECTORIZED.
- CORNERS EXTENDING BEYOND THE BORDER SHALL NOT BE TRIMMED.
- FOR STRUCTURAL DETAILS, TYPE "D" SIGNS, SEE DETAILS AND STANDARD SIGNS MANUAL.
- FOR TYPE "D" STRINGER AND PANEL-JOINT DETAIL, SEE DETAILS AND STANDARD SIGNS MANUAL.
- TYPE "C" SIGN PANELS SHALL BE FURNISHED AND INSTALLED BY SIGNAL CONTRACTOR INCIDENTAL TO ITEM NO. 2565.511 FOR EACH SIGNAL SYSTEM. SEE SPECIAL PROVISIONS.
- TYPE "D" SIGN PANELS SHALL BE INTERNALLY ILLUMINATED STREET NAME SIGN PANELS. SEE SPECIAL PROVISIONS AND DETAILS ON THIS SHEET FOR FURTHER INFORMATION.
- ALL INTERNALLY ILLUMINATED SIGN PANELS SHALL BE MEASURED AND PAID FOR BY THE SIGNAL CONTRACTOR UNDER ITEM NO. 2564.602 (INTERNALLY LIT SIGN-TYPE "D"-SIGNALS).
- SEE STANDARD SIGNS MANUAL FOR ARROW DETAILS.
- ① = SIGN PANEL TO BE MOUNTED ON MAST ARM POLE AS DIRECTED IN SPECIAL PROVISIONS.

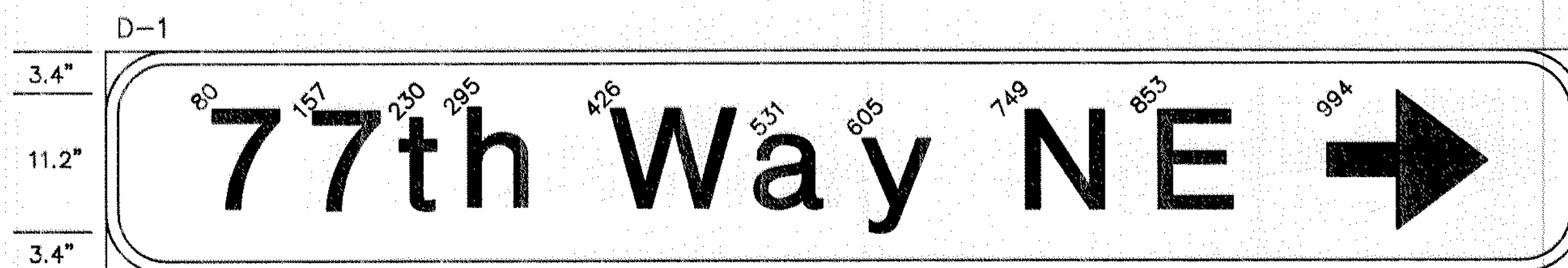

120"x18", 3"R, 1.0"B.
Line 1 104.4: 8"-6" E MOD., 5-13 ARROW 0

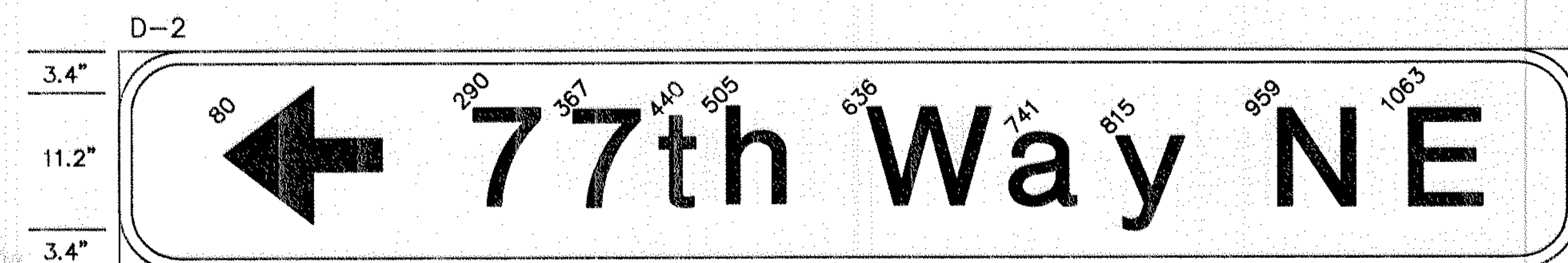

120"x18", 3"R, 1.0"B.
Line 1 104.4: 5-13 ARROW 180, 8"-6" E MOD.

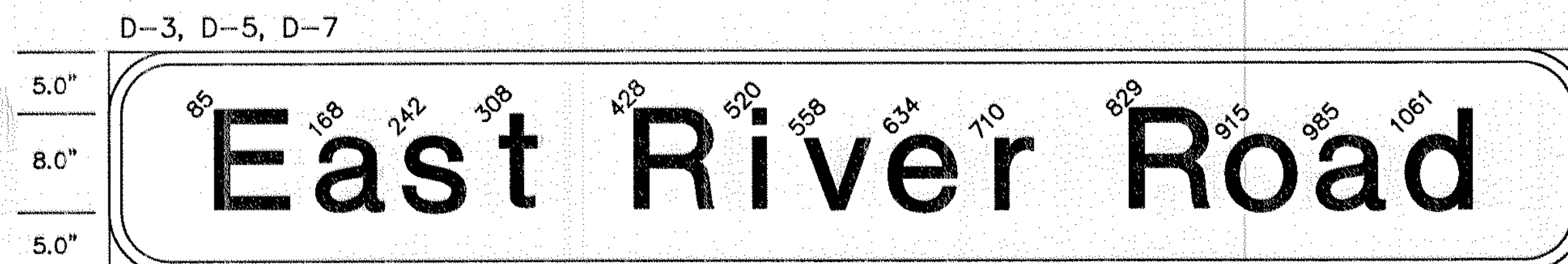

120"x18", 3"R, 1.0"B.
Line 1 102.6: 8"-6" E MOD.

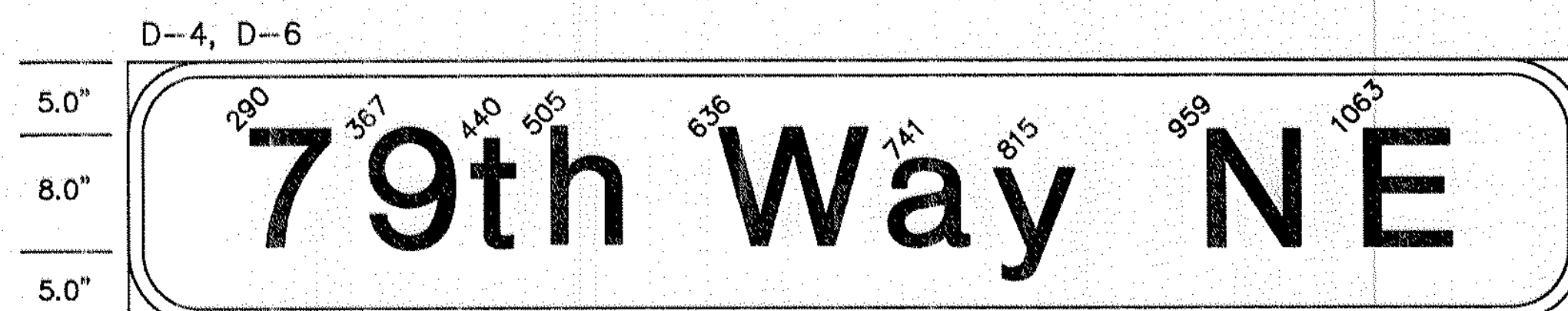

102"x18", 3"R, 1.0"B.
Line 1 84.5: 8"-6" E MOD.

NOTE: ALL DIMENSIONS OF DETAILED SIGN PANELS ARE IN INCHES.

INTERNALLY ILLUMINATED STREET NAME SIGN ELECTRICAL DETAILS

EACH SIGN (ONE PER MAST ARM POLE) IS TO BE FED WITH SEPARATE WIRES FROM THE SIGNAL SERVICE CABINET.

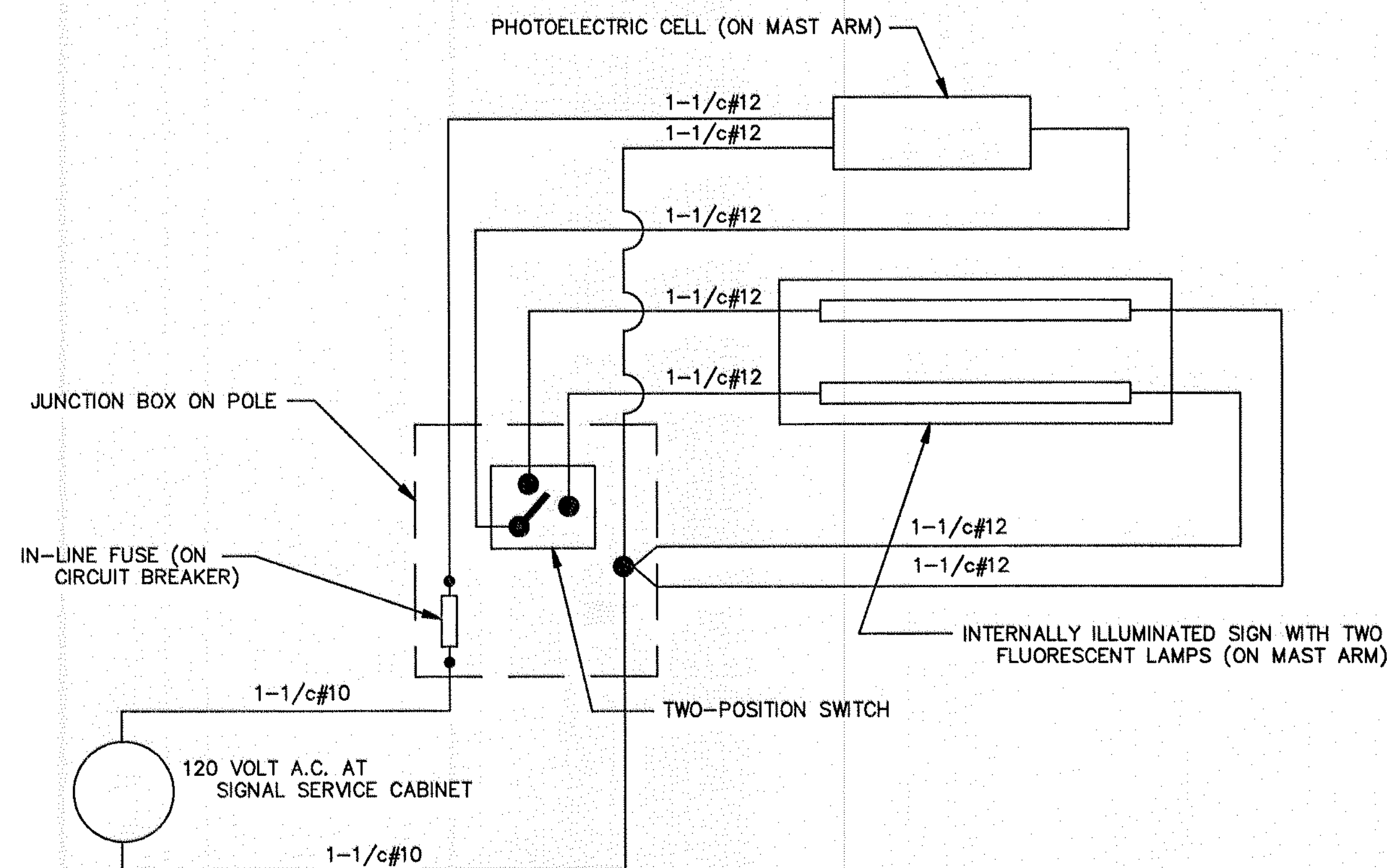
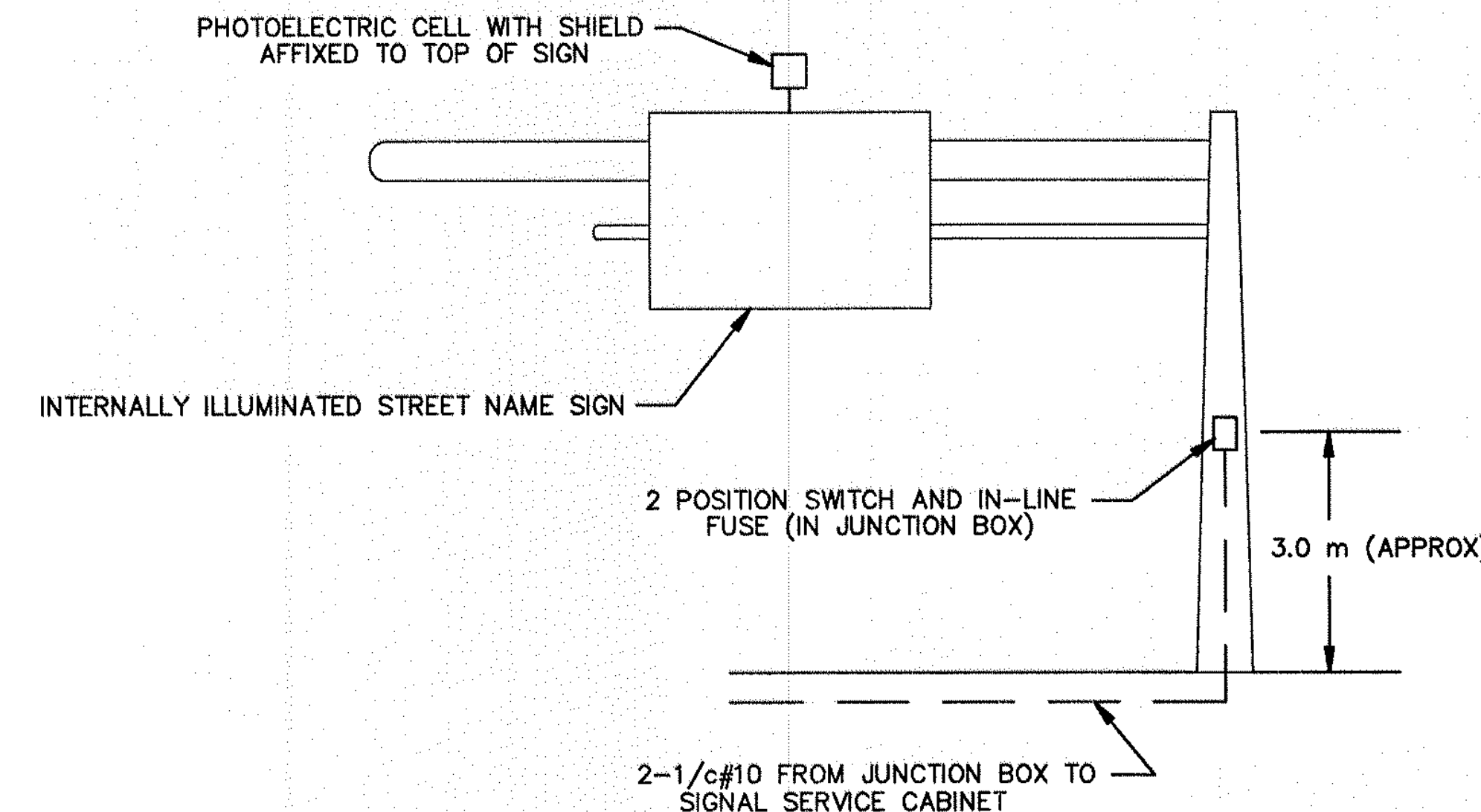

NO.	BY	DATE	REVISIONS	ITEM	DESIGN	CHECKED	DATE

I hereby certify that this plan was prepared by me or under my direct supervision and that I am a duly Registered Professional Engineer under the laws of the state of Minnesota.
Date: 3/10/98 Reg. No. 22457



ANOKA COUNTY, MINNESOTA
CITY OF FRIDLEY
S.P. 02-601-37
S.P. 127-020-20

TRAFFIC SIGNAL SYSTEMS
MAST ARM SIGNING DETAILS
EAST RIVER ROAD (CSAH 1) AT 77TH WAY NE/
79TH WAY NE

FILE NO. ANOKC9708
DATE
71
93

NOTES:

- 1) LOCATION OF POLES, CONTROLLER CABINET, SERVICE CABINET, LOOP DETECTORS AND HANDHOLES SHALL BE DETERMINED IN THE FIELD BY THE ENGINEER.
- 2) SEE SPECIAL PROVISIONS FOR COUNTY FURNISHED MATERIALS.
- 3) LOOP DETECTOR WIRES SHALL BE CROSS-LINKED POLYETHYLENE (XLP) IN 21 mm N.M.C. SEE SPECIAL PROVISIONS AND DETAILS.
- 4) NEW HANDHOLES SHALL BE PVC HANDHOLES WITH METAL FRAMES AND COVERS, PER Mn/DOT STANDARD PLATE NO. M8114A.
- 5) EACH SIGNAL FACE SHALL HAVE BACKGROUND SHIELD.
- 6) EACH PEDESTRIAN INDICATION SHALL BE A ONE SECTION HAND/WALKING PERSON INDICATION. SEE SPECIAL PROVISIONS.
- 7) ALL "RED" VEHICLE SIGNAL INDICATIONS AND ALL "HAND" PEDESTRIAN SIGNAL INDICATIONS SHALL BE LED. SEE SPECIAL PROVISIONS.
- 8) SEE SPECIAL PROVISIONS REGARDING REMOVAL AND SALVAGING OF INPLACE SIGNAL SYSTEM (INCIDENTAL TO ITEM NO.2565.511).
- 9) INPLACE ITEMS TO BE REUSED INPLACE AS PART OF THE NEW SIGNAL SYSTEM SHALL BE PROTECTED AND MAINTAINED INPLACE. SEE SPECIAL PROVISIONS.
- 10) SEE SPECIAL PROVISIONS AND DETAILS REGARDING SIGN PANELS TO BE FURNISHED AND INSTALLED BY CONTRACTOR.
- 11) CONTRACTOR SHALL PROVIDE EXTENDED BRACKETS FOR EACH POLE MOUNTED VEHICLE SIGNAL FACE.
- 12) A 21 mm HALF COUPLING, 21 mm PIPE NIPPLE AND CONDUIT OUTLET BODY SHALL BE FURNISHED AND INSTALLED APPROX. 1.8 m FROM THE LEFT END OF MAST ARM 3 AND APPROX. 8.0 m FROM THE LEFT END OF MAST ARMS 1 AND 4 (FOR EVP).
- 13) (S & R) = SALVAGE AND REINSTALL.
- 14) (INTERCONNECT) DENOTES ITEMS TO BE MEASURED AND PAID FOR SEPARATELY FROM ITEM NO. 2565.511.

LOOP DETECTORS			
NUMBER	SIZE (m)	LOCATION	FUNCTION
D1-1	2-1.7x1.7	6 m & 15 m	1
D1-2	2-1.7x1.7	1.5 m & 10.5 m	1
D2-1	1.7x1.7	100 m	1
D2-2	1.7x1.7	100 m	1
D4-1	1.7x1.7	INPLACE	3,8
D4-2	3-1.7x1.7	AS SHOWN	7
D4-3	1.7x4.6	AS SHOWN	7
D6-1	1.7x1.7	100 m	1
D6-2	1.7x1.7	100 m	1

NOTE: LOCATION=DISTANCE FROM STOP BAR TO FRONT OF LOOP DETECTOR.

LOOP DETECTORS FUNCTIONS:

- 1) CALL AND EXTEND
- 2) CALL ONLY
- 3) EXTEND ONLY
- 4) CALL ONLY DENSITY
- 5) DELAYED CALL ONLY
- 6) DELAYED CALL ONLY DENSITY
- 7) DELAYED CALL- IMMEDIATE EXTEND
- 8) CARRY OVER (STRETCH)
- 9) ADVISORY DETECTOR
- 10) SAMPLING DETECTOR
- 11) SPECIAL DETECTOR

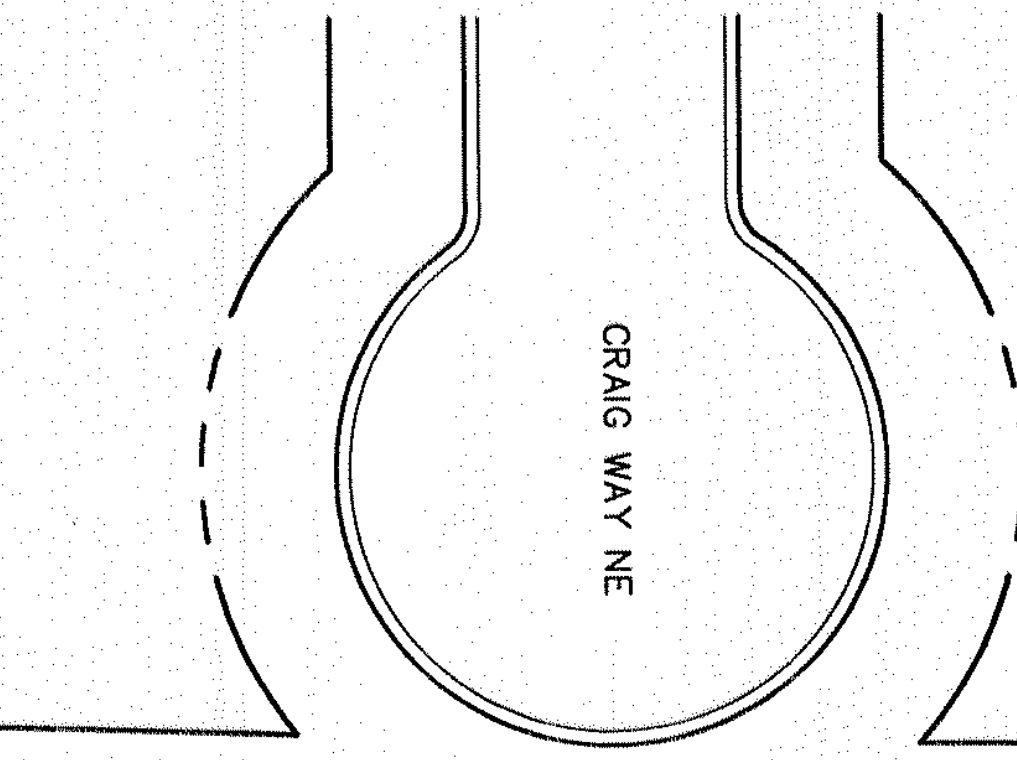

- 3) PA100 POLE FOUNDATION
TYPE PA100-A-13.7-D12-3 (DAVT AT 350°)
LUMINAIRE-200 WATT H.P.S. WITH PEC
AND CHECK SWITCH
3-ONE WAY SIGNALS-OVERHEAD (0 m, 3.3 m AND 6.9 m FROM LEFT END OF MAST ARM)
TYPE 10B-POLE MOUNTED 90°
TYPE 10A-POLE MOUNTED 270°
PEDESTRIAN PUSH BUTTON
R6-1 SIGN PANEL (915 mm x 300 mm)-
POLE MOUNTED 0°
TYPE "D" SIGN PANEL (3050 mm x 460 mm)-
OVERHEAD (D-2)-INTERNALLY ILLUMINATED
INSTALL ONE WAY EVP DETECTOR AND LIGHT-OVERHEAD (#6.1)-SEE SPECIAL PROVISIONS
EXTEND INTO H.H.9:
78 mm R.S.C.
2-12/c#12
3-3/c#12
1-3/c#20
1-3/c#12 (LUM)
2-1/c#10 (ST.NAME SIGN)

- 4) PA90 POLE FOUNDATION
TYPE PA90-A-9.1
ONE WAY SIGNAL-OVERHEAD
TYPE 10B-POLE MOUNTED 0°
PEDESTRIAN PUSH BUTTON
TYPE "D" SIGN PANEL (3050 mm x 460 mm)-
OVERHEAD (D-3)-INTERNALLY ILLUMINATED
INSTALL ONE WAY EVP DETECTOR
AND LIGHT-OVERHEAD (#4)-
SEE SPECIAL PROVISIONS
EXTEND INTO H.H.10:
78 mm R.S.C.
1-12/c#12
2-3/c#12
1-3/c#20
2-1/c#10 (ST.NAME SIGN)

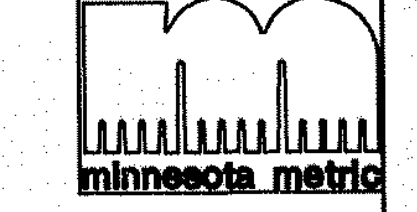
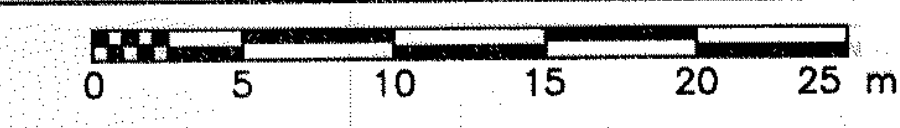

- A) INSTALL CONTROLLER AND CABINET (FURNISHED BY COUNTY)
CABINET FOUNDATION
EXTEND INTO H.H.16:
METERED SIGNAL SERVICE
35 mm R.S.C.
3-1/c#6
EXTEND INTO H.H.1:
103 mm R.S.C.
3-12/c#12
5-3/c#12
1-3/c#20
1-3/c#20-INPLACE (S & R)
5-2/c#14

EXTEND INTO H.H.15:
103 mm R.S.C.
3-12/c#12
4-3/c#12
2-3/c#20
4-2/c#14
1-6 Pr.#19 (INTERCONNECT)
STUB OUT 1-53 mm R.S.C. AND 1-78 mm R.S.C.
FROM CABINET TO SOUTH (THREAD AND CAP BOTH ENDS-FOR FUTURE USE)

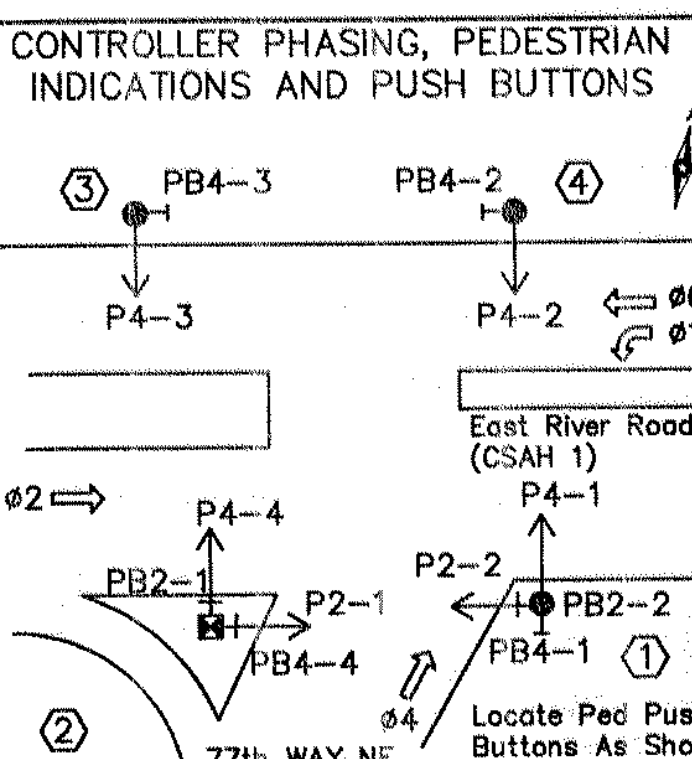
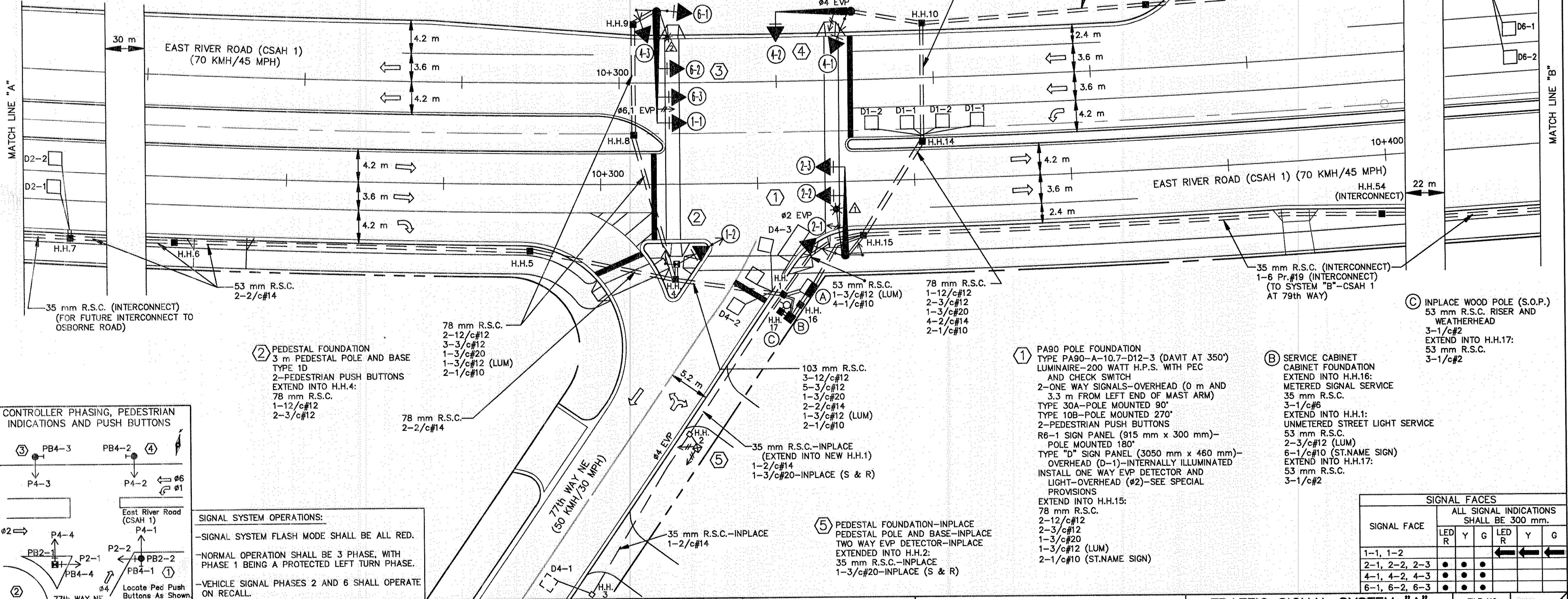

SIGNAL SYSTEM OPERATIONS:
-SIGNAL SYSTEM FLASH MODE SHALL BE ALL RED.
-NORMAL OPERATION SHALL BE 3 PHASE, WITH PHASE 1 BEING A PROTECTED LEFT TURN PHASE.
-VEHICLE SIGNAL PHASES 2 AND 6 SHALL OPERATE ON RECALL.

I hereby certify that this plan was prepared by me or under my direct supervision and that I am a duly Registered Professional Engineer under the laws of the state of Minnesota.
Date: 3/10/98 Reg. No. 22457



ANOKA COUNTY, MINNESOTA
CITY OF FRIDLEY
S.P. 02-601-37
S.P. 127-020-20

TRAFFIC SIGNAL SYSTEM "A"
INTERSECTION LAYOUT
EAST RIVER ROAD (CSAH 1) AT 77TH WAY NE

SIGNAL FACES						
ALL SIGNAL INDICATIONS SHALL BE 300 mm.						
SIGNAL FACE	LED R			LED Y G		
	R	Y	G	R	Y	G
1-1, 1-2	•	•	•	•	•	•
2-1, 2-2, 2-3	•	•	•	•	•	•
4-1, 4-2, 4-3	•	•	•	•	•	•
6-1, 6-2, 6-3	•	•	•	•	•	•

NO.	BY	DATE	REVISIONS	ITEM	DESIGN	CHECKED

FILE NO. ANOKC9708	72
DATE	
	93

BASE OVERLAY DRG. NO.

CONTROLLER CABINET

Fed. Project No.

CONDUCTOR COLOR CODING

R	BLK	
O	WH	2-1/c#6
BL		
WH		
R/BLK	R	
O/BLK	WH	3/c#12
BL/BLK	BLK	
WH/BLK		
BLK	BLK	2/c#14
BLK/WH	CLEAR	
G/BLK		
G		
	R OR O	
	WH OR YEL	3/c#20
	BLK OR BL	

NOTE:
ALL TERMINAL BLOCK CONNECTIONS
SHALL BE ARRANGED AS SPECIFIED ABOVE.

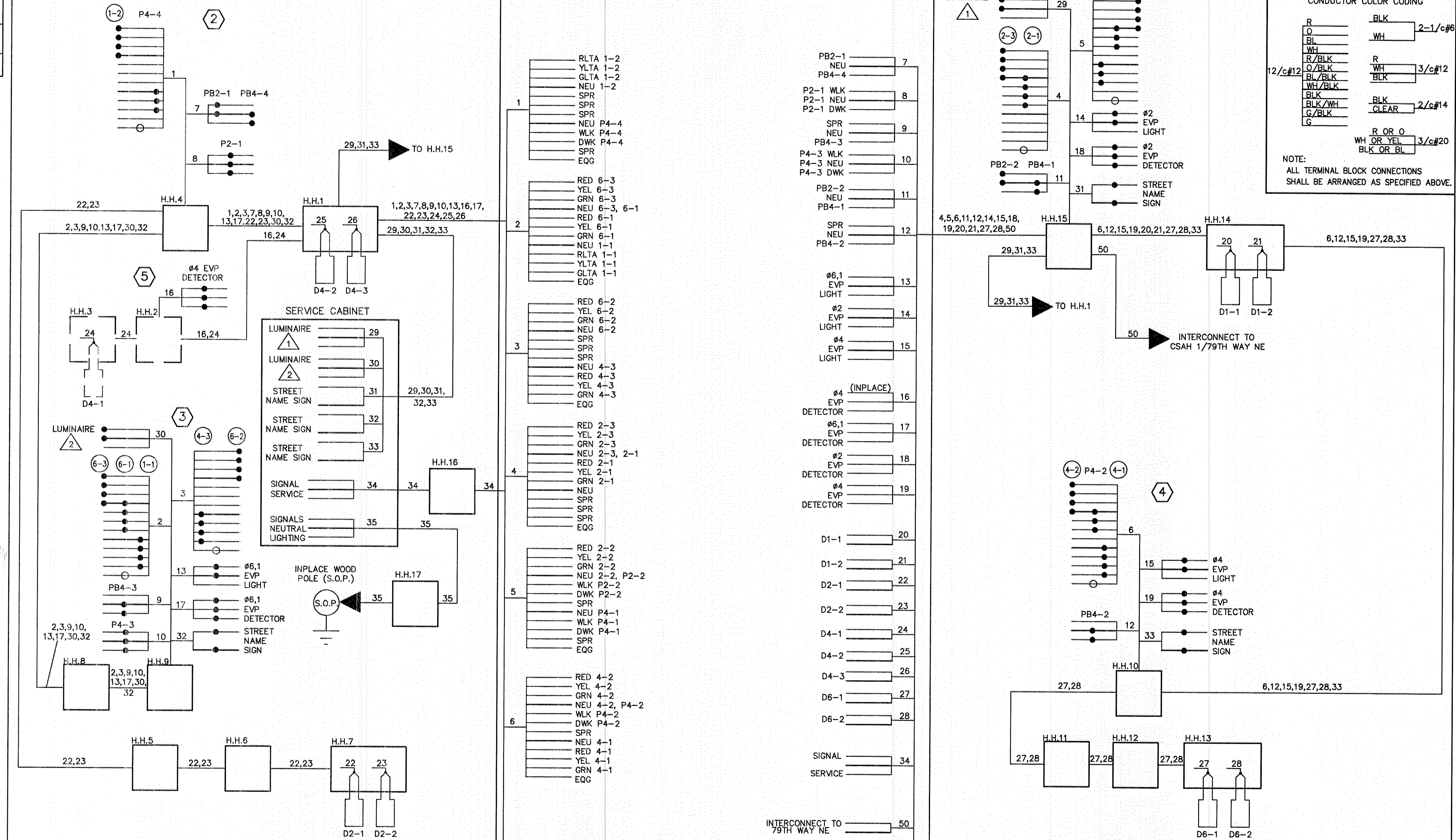

NO.	BY	DATE	REVISIONS	ITEM	DESIGN	CHECKED

I hereby certify that this plan was prepared by me or under my direct supervision and that I am a duly Registered Professional Engineer under the laws of the State of Minnesota.
John M. Jones
 Date: 3/10/98 Reg. No. 22457



ANOKA COUNTY, MINNESOTA
 CITY OF FRIDLEY
 S.P. 02-601-37
 S.P. 127-020-20

TRAFFIC SIGNAL SYSTEM "A"
 FIELD WIRING DIAGRAM
 EAST RIVER ROAD (CSAH 1) AT 77TH WAY NE

FILE NO.
 ANOKC9708
 DATE
 73
 93

NOTES:

- 1) LOCATION OF POLES, CONTROLLER CABINET, SERVICE CABINET, LOOP DETECTORS AND HANDHOLES SHALL BE DETERMINED IN THE FIELD BY THE ENGINEER.
- 2) SEE SPECIAL PROVISIONS FOR COUNTY FURNISHED MATERIALS.
- 3) LOOP DETECTOR WIRES SHALL BE CROSS-LINKED POLYETHYLENE (XLP) IN 21 mm N.M.C. SEE SPECIAL PROVISIONS AND DETAILS.
- 4) NEW HANDHOLES SHALL BE PVC HANDHOLES WITH METAL FRAMES AND COVERS, PER Mn/DOT STANDARD PLATE NO.MB114A.
- 5) EACH SIGNAL FACE SHALL HAVE BACKGROUND SHIELD.
- 6) EACH PEDESTRIAN INDICATION SHALL BE A ONE SECTION HAND/WALKING PERSON INDICATION. SEE SPECIAL PROVISIONS.
- 7) ALL "RED" VEHICLE SIGNAL INDICATIONS AND ALL "HAND" PEDESTRIAN SIGNAL INDICATIONS SHALL BE LED. SEE SPECIAL PROVISIONS.
- 8) SEE SPECIAL PROVISIONS REGARDING REMOVAL AND SALVAGING OF INPLACE SIGNAL SYSTEM (INCIDENTAL TO ITEM NO.2565.511).
- 9) SEE SPECIAL PROVISIONS AND DETAILS REGARDING SIGN PANELS TO BE FURNISHED AND INSTALLED BY CONTRACTOR.
- 10) CONTRACTOR SHALL PROVIDE EXTENDED BRACKETS FOR EACH POLE MOUNTED VEHICLE SIGNAL FACE.
- 11) A 21 mm HALF COUPLING, 21 mm PIPE NIPPLE AND CONDUIT OUTLET BODY SHALL BE FURNISHED AND INSTALLED APPROX. 1.8 m FROM THE LEFT END OF EACH MAST ARM (FOR EVP).
- 12) VEHICLE SIGNAL FACES 3-2 AND 4-2 SHALL BE OPTICALLY PROGRAMMED SIGNAL FACES. SEE SPECIAL PROVISIONS.
- 13) (INTERCONNECT) DENOTES ITEMS TO BE MEASURED AND PAID FOR SEPARATELY FROM ITEM NO. 2565.511.

LOOP DETECTORS			
NUMBER	SIZE (m)	LOCATION	FUNCTION
D1-1	2-1.7x1.7	6 m & 15 m	1
D1-2	2-1.7x1.7	1.5 m & 10.5 m	1
D2-1	1.7x1.7	100 m	1
D2-2	1.7x1.7	100 m	1
D3-1	1.7x3.0	35 m	3,8
D3-2	3-1.7x1.7	AS SHOWN	7
D3-3	2-1.7x1.7	AS SHOWN	7
D4-1	1.7x3.6	35 m	3,8
D4-2	2-1.7x1.7	AS SHOWN	7
D4-3	2-1.7x1.7	AS SHOWN	7
D4-4	3-1.7x1.7	AS SHOWN	1
D5-1	2-1.7x1.7	6 m & 15 m	1
D5-2	2-1.7x1.7	1.5 m & 10.5 m	1
D6-1	1.7x1.7	100 m	1
D6-2	1.7x1.7	100 m	1

NOTE: LOCATION=DISTANCE FROM STOP BAR TO FRONT OF LOOP DETECTOR.

LOOP DETECTORS FUNCTIONS:

- 1) CALL AND EXTEND
- 2) CALL ONLY
- 3) EXTEND ONLY
- 4) CALL ONLY DENSITY
- 5) DELAYED CALL ONLY
- 6) DELAYED CALL- IMMEDIATE EXTEND
- 7) CARRY OVER (STRETCH)
- 8) ADVISORY DETECTOR
- 9) SAMPLING DETECTOR
- 10) SPECIAL DETECTOR

- 5) PEDESTAL FOUNDATION
3 m PEDESTAL POLE AND BASE
TYPE 2B
PEDESTRIAN PUSH BUTTON
EXTEND INTO H.H.9:
78 mm R.S.C.
1-12/c#12
2-3/c#12

- 4) PA100 POLE FOUNDATION
TYPE PA100-A-12.2-D12-3 (DAVIT AT 350)
LUMINAIRE-200 WATT H.P.S. WITH PEC
AND CHECK SWITCH
3-ONE WAY SIGNALS-OVERHEAD (0 m, 3.3 m
AND 6.9 m FROM LEFT END OF MAST ARM)
TYPE 10B-POLE MOUNTED 270°
PEDESTRIAN PUSH BUTTON
R6-1 SIGN PANEL (915 mm x 300 mm)-
POLE MOUNTED 0°
TYPE "D" SIGN PANEL (2595 mm x 460 mm)-
OVERHEAD (D-6)-INTERNALLY ILLUMINATED
ONE WAY EVP DETECTOR AND LIGHT-
OVERHEAD (#6,1)
EXTEND INTO H.H.8:
78 mm R.S.C.
2-12/c#12
2-3/c#12
1-3/c#20
1-3/c#20
1-3/c#12 (LUM)
2-1/c#10 (ST.NAME SIGN)

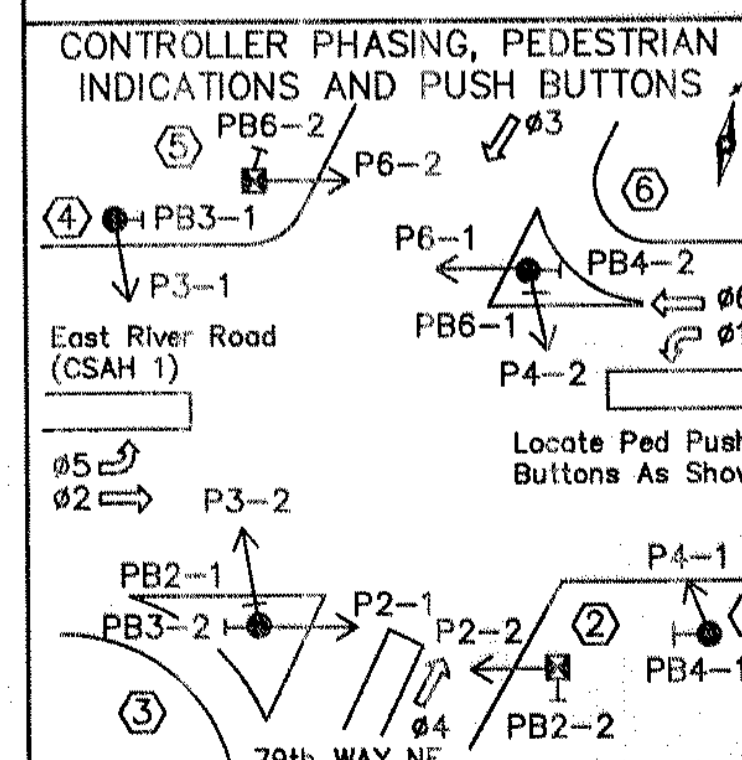
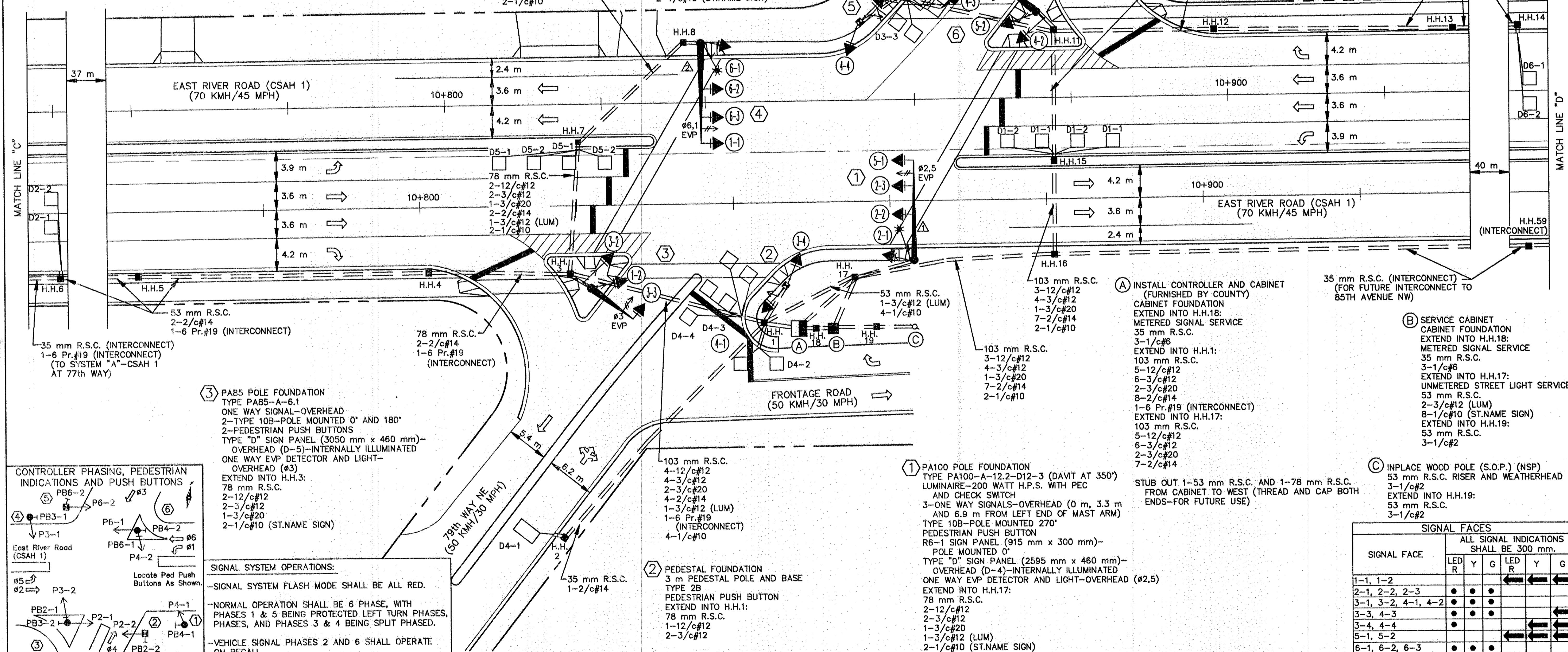

SIGNAL SYSTEM OPERATIONS:
-SIGNAL SYSTEM FLASH MODE SHALL BE ALL RED.
-NORMAL OPERATION SHALL BE 6 PHASE, WITH PHASES 1 & 5 BEING PROTECTED LEFT TURN PHASES, PHASES, AND PHASES 3 & 4 BEING SPLIT PHASES.
-VEHICLE SIGNAL PHASES 2 AND 6 SHALL OPERATE ON RECALL.

SIGNAL FACES						
SIGNAL FACE	ALL SIGNAL INDICATIONS SHALL BE 300 mm.					
	LED R	Y	G	LED R	Y	G
1-1, 1-2				←	←	←
2-1, 2-2, 2-3	•	•	•			
3-1, 3-2, 4-1, 4-2	•	•	•			
3-3, 4-3	•	•	•			
3-4, 4-4	•	•	•			
5-1, 5-2				←	←	←
6-1, 6-2, 6-3	•	•	•			

I hereby certify that this plan was prepared by me or under my direct supervision and that I am a duly Registered Professional Engineer under the laws of the state of Minnesota.
Date: 3/10/98 Reg. No. 22457



ANOKA COUNTY, MINNESOTA
CITY OF FRIDLEY
S.P. 02-601-37
S.P. 127-020-20

TRAFFIC SIGNAL SYSTEM "B"
INTERSECTION LAYOUT
EAST RIVER ROAD (CSAH 1) AT 79TH WAY NE

FILE NO. ANOKC9708
DATE
74
93

BASE OVERLAY DRG. NO.

CONTROLLER CABINET

Fed. Project No.

CONDUCTOR COLOR CODING	
R	BLK 2-1/c#6
O	WH 2-1/c#6
BL	WH 3/c#12
R/BLK	R WH 3/c#12
O/BLK	WH BLK 3/c#12
WH/BLK	BLK WH 3/c#12
BLK	BLK 2/c#14
BLK/WH	CLEAR 2/c#14
G/BLK	R OR O WH OR YEL 3/c#20
G	BLK OR BL 3/c#20

NOTE:
ALL TERMINAL BLOCK CONNECTIONS SHALL BE ARRANGED AS SPECIFIED ABOVE.

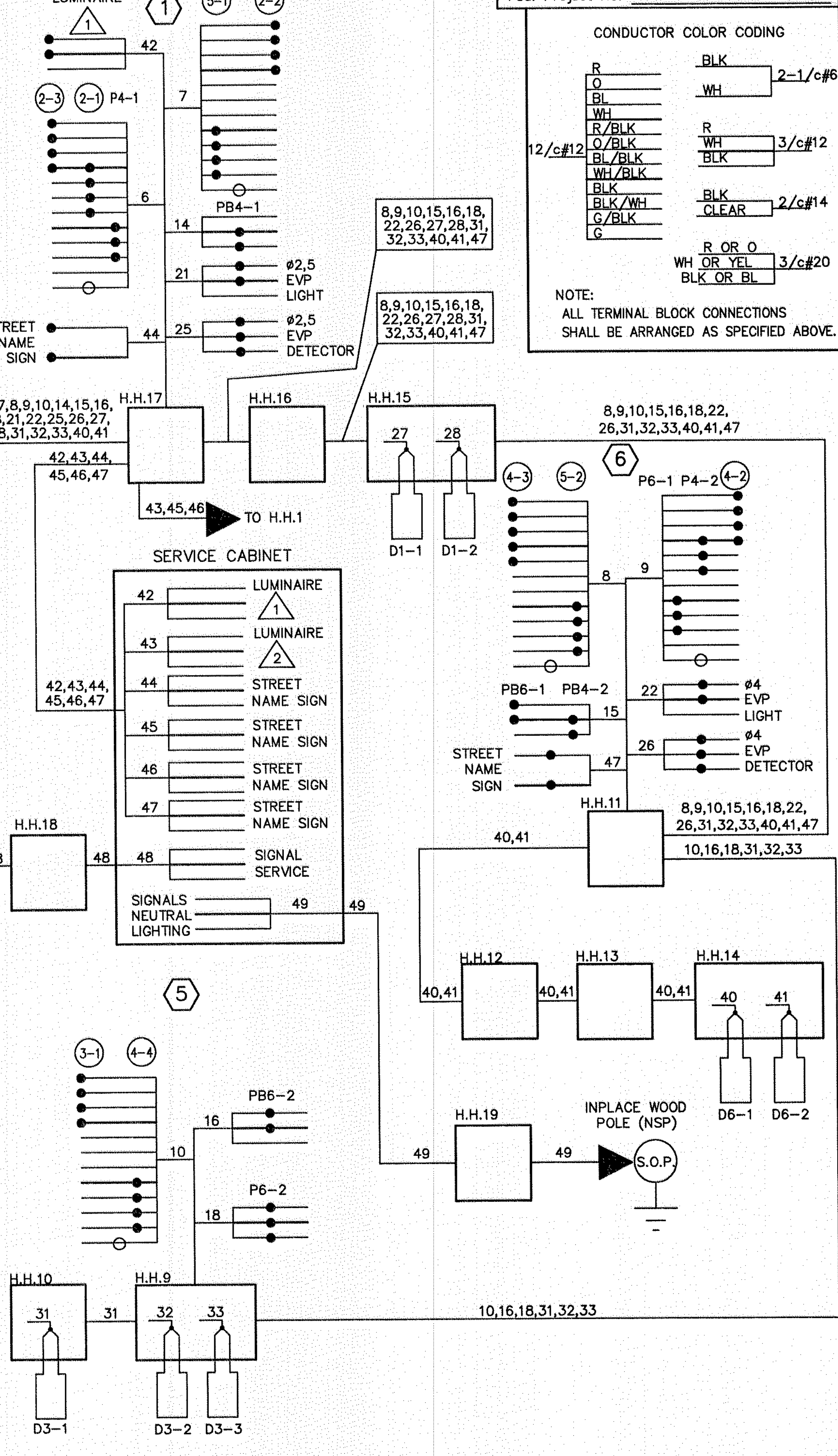
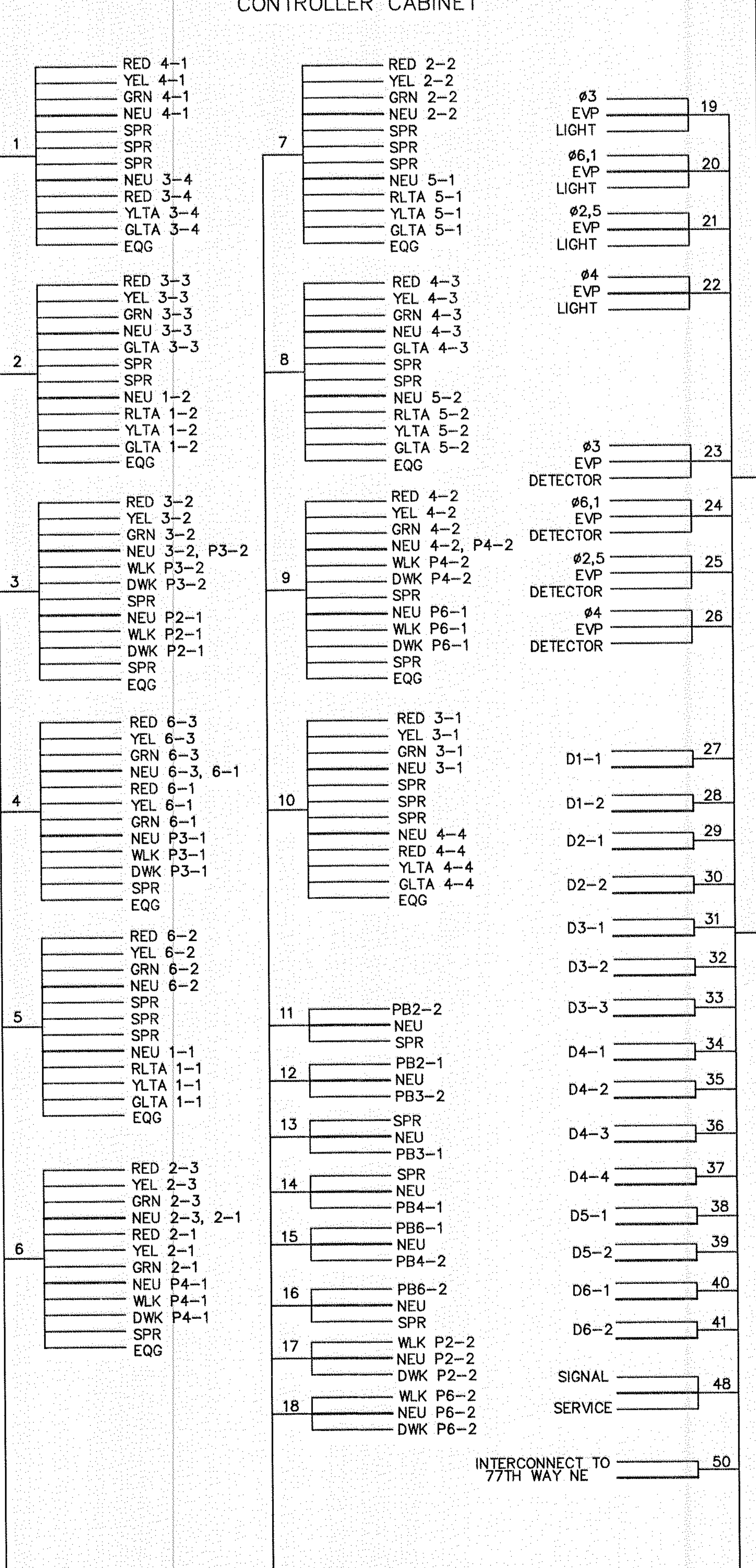
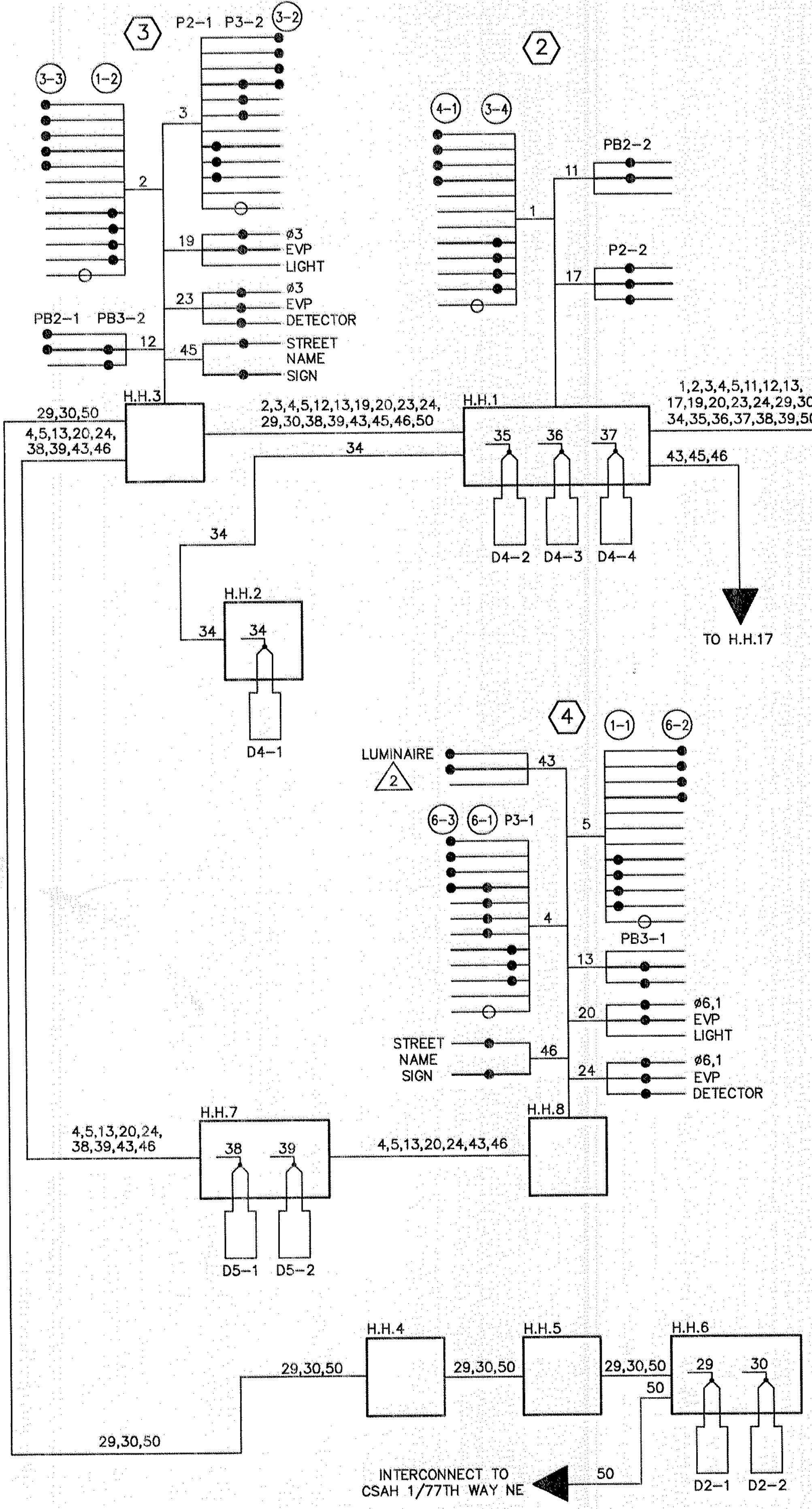

NO.	BY	DATE	REVISIONS	ITEM	DESIGN	CHECKED

I hereby certify that this plan was prepared by me or under my direct supervision and that I am a duly Registered Professional Engineer under the laws of the State of Minnesota.

Date: 3/10/98 Reg. No. 22457



ANOKA COUNTY, MINNESOTA
CITY OF FRIDLEY
S.P. 02-601-37
S.P. 127-020-20

TRAFFIC SIGNAL SYSTEM "B"
FIELD WIRING DIAGRAM
EAST RIVER ROAD (CSAH 1) AT 79TH WAY NE

FILE NO. ANOKC9708
DATE
75
93

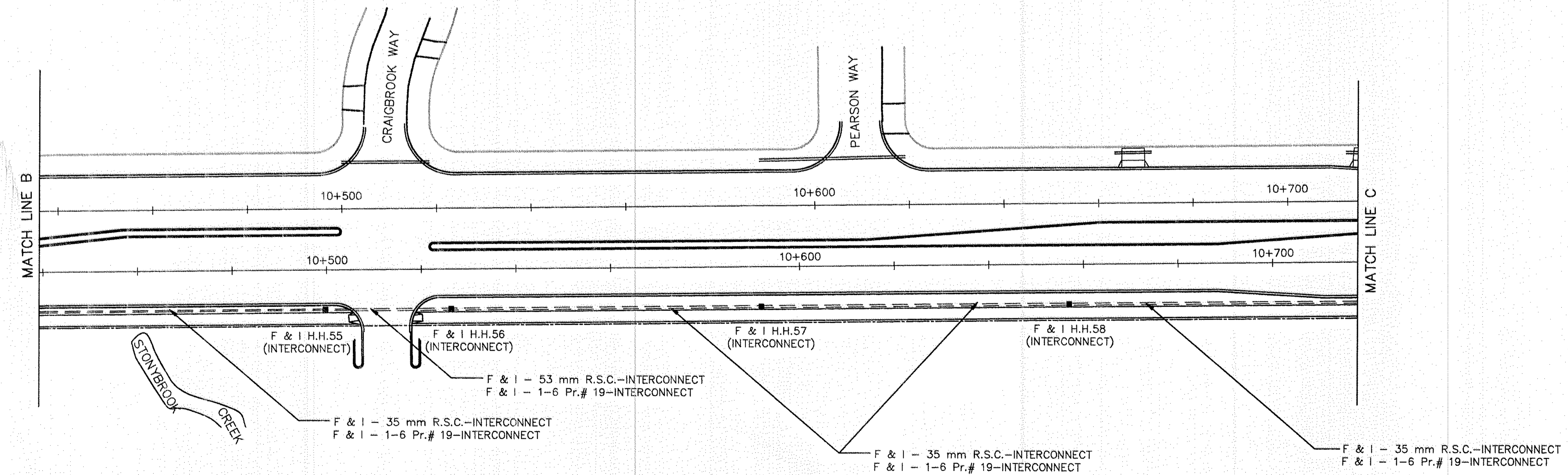
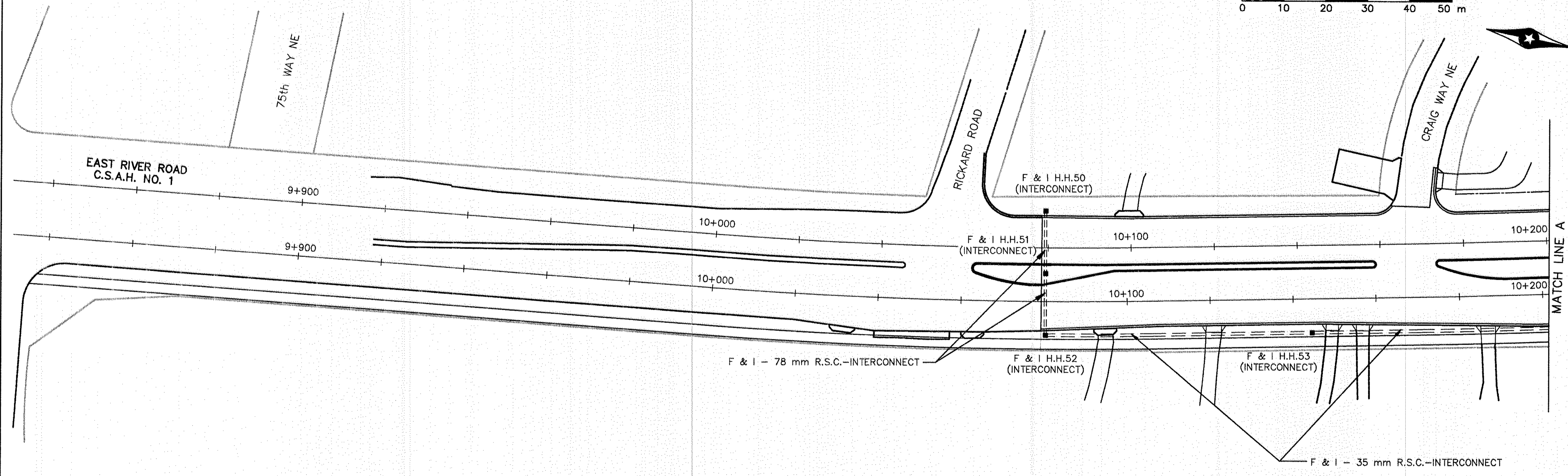
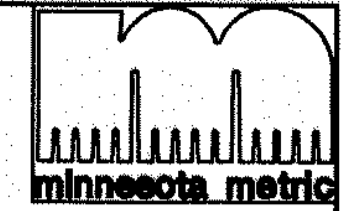
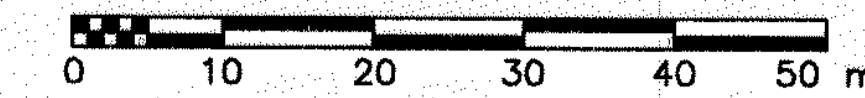

NO.	BY	DATE	REVISIONS	ITEM	DESIGN	CHECKED

I hereby certify that this plan was prepared by me or under my direct supervision and that I am a duly Registered Professional Engineer under the laws of the state of Minnesota.

John M. Jones
 Date: 3/10/98 Reg. No. 22457



ANOKA COUNTY, MINNESOTA
CITY OF FRIDLEY
 S.P. 02-601-37
 S.P. 127-020-20

TRAFFIC SIGNAL INTERCONNECT
MATCH LINES
 EAST RIVER ROAD (CSAH 1) (BETWEEN
 OSBORNE ROAD AND 79TH WAY NE)

FILE NO. ANOKC970B	76
DATE	93

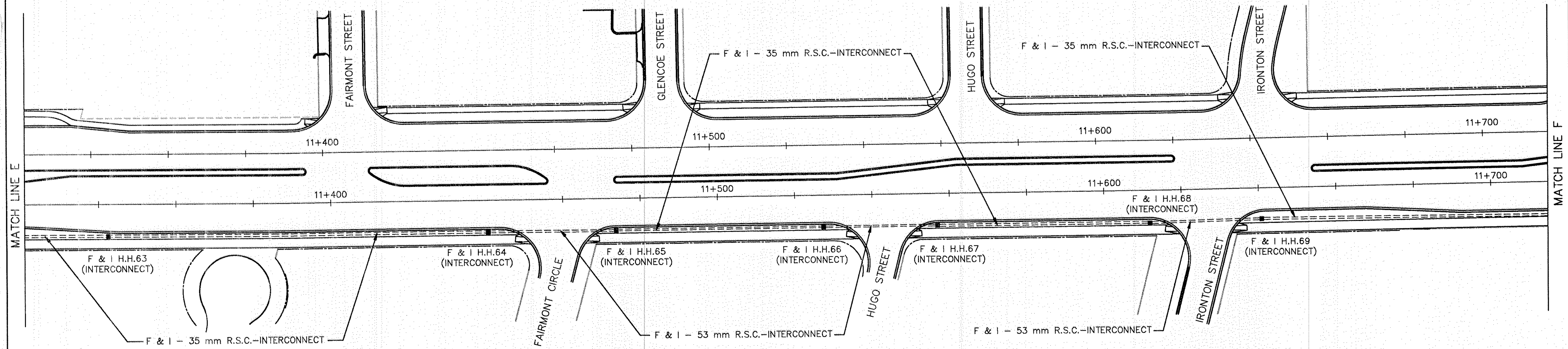
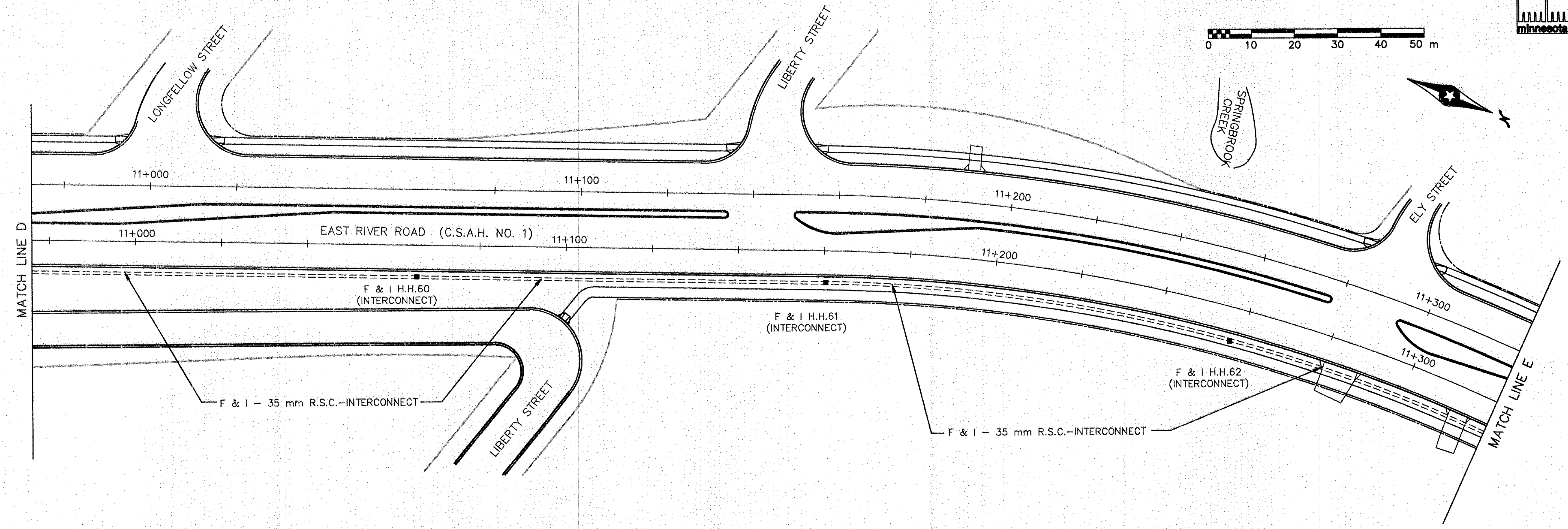
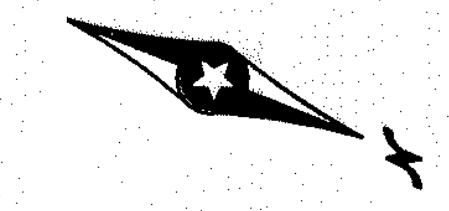
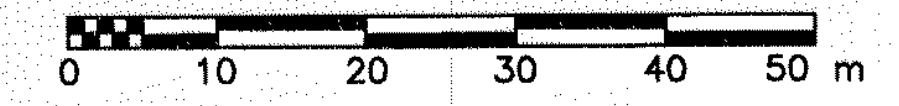

NO.	BY	DATE	REVISIONS	ITEM	DESIGN	CHECKED

I hereby certify that this plan was prepared by me or under my direct supervision and that I am a duly Registered Professional Engineer under the laws of the state of Minnesota.

John M. Jones
 Date: 3/10/98 Reg. No. 22457



ANOKA COUNTY, MINNESOTA
 CITY OF FRIDLEY
 S.P. 02-601-37
 S.P. 127-020-20

TRAFFIC SIGNAL INTERCONNECT
 MATCH LINES
 EAST RIVER ROAD (CSAH 1) (BETWEEN
 79TH WAY NE AND 85TH AVENUE)

FILE NO.	77
ANOKC9708	
DATE	93

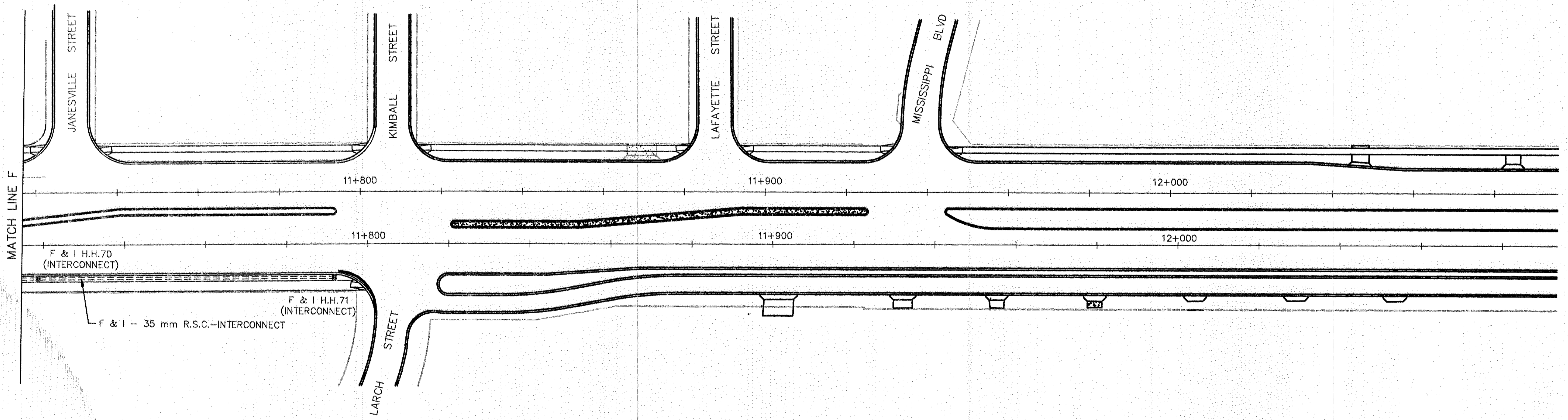
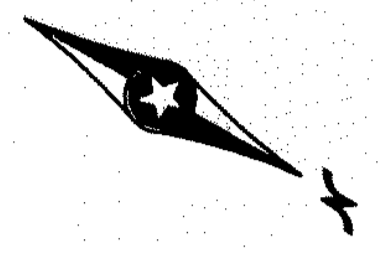

NO.	BY	DATE	REVISIONS	ITEM	DESIGN	CHECKED

I hereby certify that this plan was prepared by me or under my direct supervision and that I am a duly Registered Professional Engineer under the laws of the state of Minnesota.

John M. Jones
 Date: 3/10/98 Reg. No. 22457



ANOKA COUNTY, MINNESOTA
 CITY OF FRIDLEY
 S.P. 02-601-37
 S.P. 127-020-20

TRAFFIC SIGNAL INTERCONNECT
 MATCH LINES
 EAST RIVER ROAD (CSAH 1) (BETWEEN
 OSBORNE ROAD AND 79TH WAY NE)

FILE NO. ANOKC9708	78
DATE	93

① 40' WOOD POLE FOUNDATION TYPE 10B MOUNTED AT 90° TYPE 10A MOUNTED AT 180° LUMINAIRE AND EXTENSION (BY OTHERS) PEDESTRIAN PUSH BUTTON AND SIGN JUNCTION BOX #1 2" R.S.C. RISER AND WEATHERHEAD 2-12/C #12 1-3/C #12

② 40' WOOD POLE-CLASS 2 TYPE 10A MOUNTED AT 270° TYPE 10A MOUNTED AT 180° TYPE 10B MOUNTED AT 90° 2-DOWN GUY, GUARD, AND ANCHORS PEDESTRIAN PUSH BUTTON AND SIGN JUNCTION BOX #2 2" R.S.C. RISER AND WEATHERHEAD 3-12/C #12 1-3/C #12 2-2/C #14 1 1/4" R.S.C. RISER BELOW JUNCTION BOX #2 EXTEND INTO HH 6 WITH: 2-2/C #14

③ 40' WOOD POLE-CLASS 2 TYPE 30A POLE MOUNTED AT 90° TYPE 10A MOUNTED AT 270° LUMINAIRE AND EXTENSION (BY OTHERS) 2-DOWN GUY, GUARD, AND ANCHORS PEDESTRIAN PUSH BUTTON AND SIGN PEDESTRIAN WALK JUNCTION BOX #3 2" R.S.C. RISER AND WEATHERHEAD 1-12/C #12 1-3/C #12 4-2/C #14 1-3/C #20 2" R.S.C. RISER BELOW JUNCTION BOX #3 EXTEND INTO HH 3 WITH: 1-12/C #12 1-3/C #12 4-2/C #14 1-3/C #20

④ 8' PEDESTAL POLE AND BASE PEDESTAL FOUNDATION TYPE 4A PEDESTRIAN PUSH BUTTON AND SIGN PEDESTRIAN WALK (SEE DETAIL "A") 2" R.S.C. EXTENDED INTO HH 3 WITH: 1-12/C #12 1-3/C #12

⑤ 40' WOOD POLE-CLASS 2 TYPE 10B POLE MOUNTED AT 0° TYPE 30A POLE MOUNTED AT 180° 2-DOWN GUY, GUARD AND ANCHORS 2-PEDESTRIAN PUSH BUTTONS AND SIGNS PEDESTRIAN WALK JUNCTION BOX #5 2-2" R.S.C. RISERS EXTEND INTO HH 1 WITH: 6-12/C #12 3-3/C #12 6-2/C #14 3-3/c #20 2-2" R.S.C. RISERS AND WEATHERHEADS ABOVE J.B. 5 WITH: 5-12/C #12 3-3/c #12 6-2/C #14 3-3/c #20

A CONTROLLER AND CABINET CABINET FOUNDATION EXTEND 2-3" R.S.C. INTO HH 1 WITH: 6-12/C #12 3-3/C #12 7-2/C #14 4 3/4" #20 EXTEND INTO HH 2 METERED SIGNAL SERVICE 1-1/4" R.S.C. 3-1/c #6

B SERVICE CABINET CABINET FOUNDATION EXTEND INTO HH 2 METERED SIGNAL SERVICE 1 1/4" R.S.C. 3-1/c #6 EXTEND INTO HH 5 2" R.S.C. 3-1/c #6 1-1/c #6 BR. GR.

⑥ 8' PEDESTAL POLE AND BASE PEDESTAL FOUNDATION 2-WAY EVP DETECTOR EXTEND INTO HH 9: 1 1/4" R.S.C. 1-3/c #20

NOTES:
 1) SEE SPECIAL PROVISIONS FOR CONTRACTOR'S RESPONSIBILITY FOR LOCATION OF UTILITIES.
 2) ALL SIGNAL FACES SHALL HAVE BACKGROUND SHIELDS.
 3) LUMINAIRE AT LOCATIONS 1 AND 3 TO BE INSTALLED BY OTHERS.
 4) SEE SPECIAL PROVISIONS FOR ANOKA COUNTY SERVICE CABINET DETAILS.
 5) HANDHOLES SHALL BE CONCRETE WITH CONCRETE COVERS.
 6) LOOP DETECTOR WIRES SHALL BE CROSS LINKED POLYETHYLENE (CLP) IN 1" N.M.C. SEE SPECIAL PROVISIONS.
 7) ALL PEDESTRIAN INDICATORS SHALL BE 12" x 12"
 8) CONTRACTOR SHALL INSTALL COUNTY FURNISHED CONTROLLER AND CABINET. SEE SPECIAL PROVISIONS.
 9) CONTRACTOR SHALL RESTORE AREAS DISTURBED DURING CONSTRUCTION SOO SHALL BE USED ON THE SOUTHEAST CORNER OF THE INTERSECTION, SEED SHALL BE USED ON ALL OTHER AREAS. SEE SPECIAL PROVISIONS.
 10) CONTRACTOR SHALL INSTALL CITY-FURNISHED EVP DETECTOR, LEAD IN CABLE AND PEDESTRIAN LIGHTS AT LOCATIONS INDICATED IN THE PLANS. THE CITY SHALL HAVE THE OPTION OF ADDING ONE ADDITIONAL EVP DETECTOR AT A LOCATION TO BE DETERMINED AT THE TIME OF INSTALLATION.

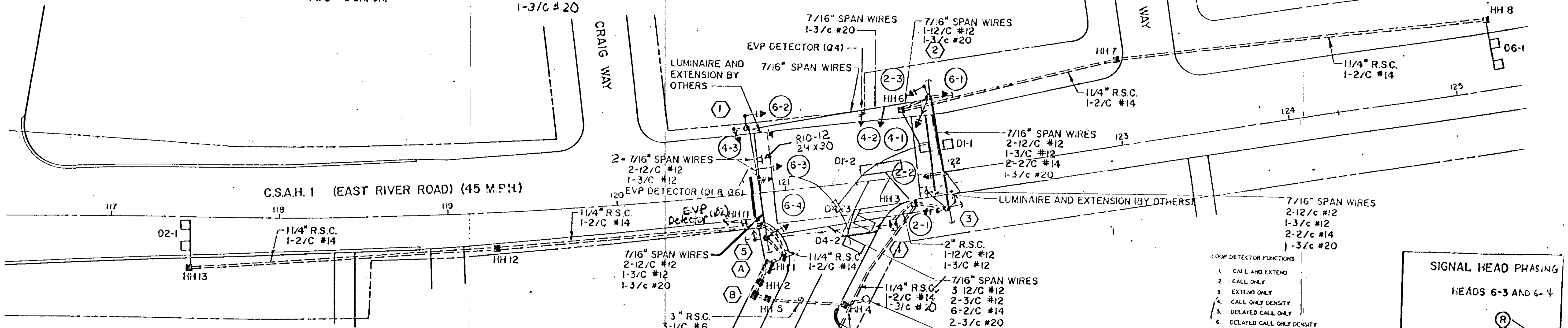

SIGNAL INDICATIONS							
FACE	PHASE	FLASH	R	Y	G	Y	G
2-1	2	R	12"	12"	12"		
2-2	2	R	12"	12"	12"		
2-3	2	R	12"	12"	12"		
4-1	4	R	12"	12"	12"		
4-2	4	R	12"	12"	12"		
4-3	4	R	12"	12"	12"		
6-1	6	R	12"	12"	12"		
6-2	6	R	12"	12"	12"		
6-3	1 & 6	R	12"	12"	12"	12"	12"
6-4	1 & 6	R	12"	12"	12"	12"	12"

LOOP DETECTORS			
NUMBER	SIZE	LOCATION	FUNCTION
D1-1	2-6'x6'	—	5 & 8
D1-2	6'x24'	—	12
D2-1	2-6'x6'	330'	1
D4-1	6'x12'	180'	3, 8
D4-2	6'x12'	—	7
D4-3	6'x12'	—	7
D6-1	2-6'x6'	330'	1

* DISTANCE TO STOP BAR

- LOOP DETECTOR FUNCTIONS
1. CALL AND EXTEND
 2. CALL ONLY
 3. EXTEND ONLY
 4. CALL ONLY DENSITY
 5. DELAYED CALL ONLY
 6. DELAYED CALL ONLY DENSITY
 7. DELAYED CALL - IMMEDIATE EXTEND
 8. CARRY OVER (STRETCH)
 9. ADVISORY DETECTOR
 10. SAMPLING DETECTOR
 11. SPECIAL DETECTOR
 12. EXTEND ONLY (OPERATES DURING OR ONLY)

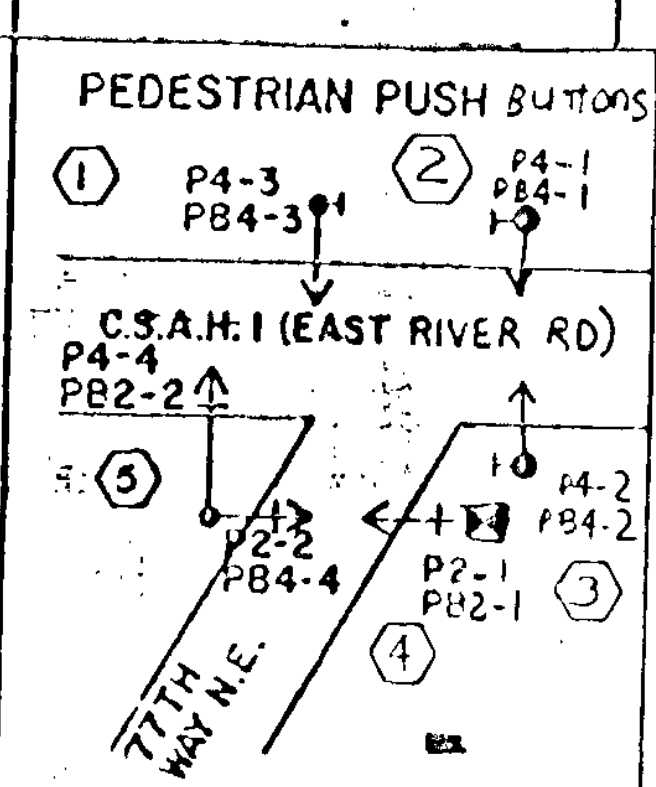
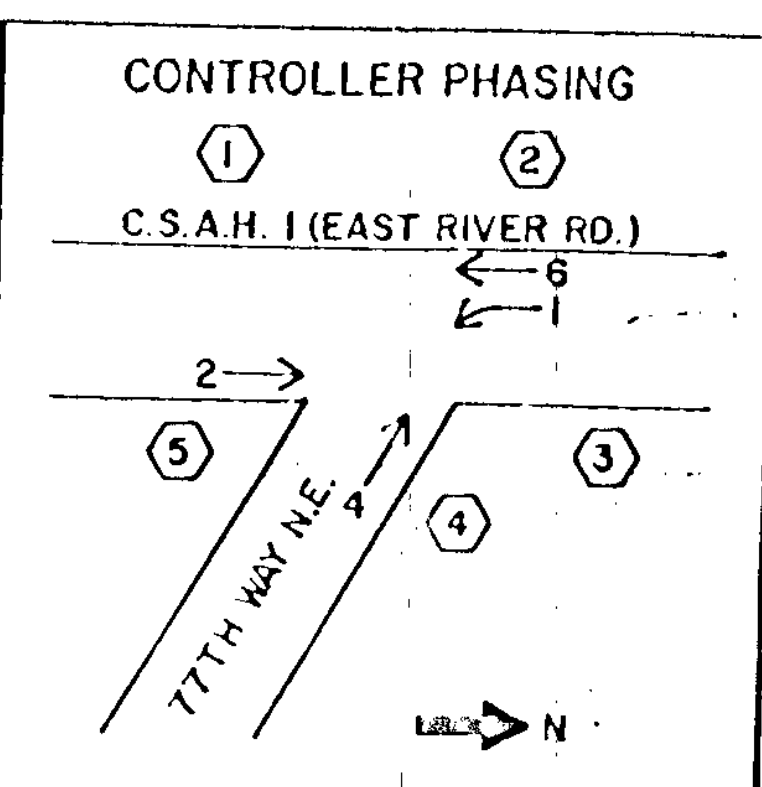
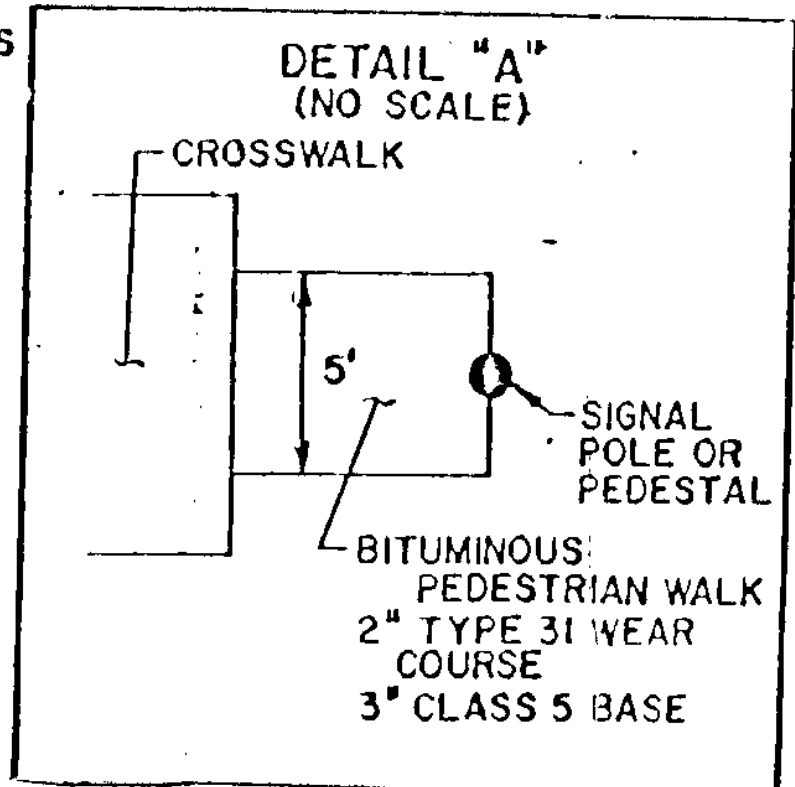
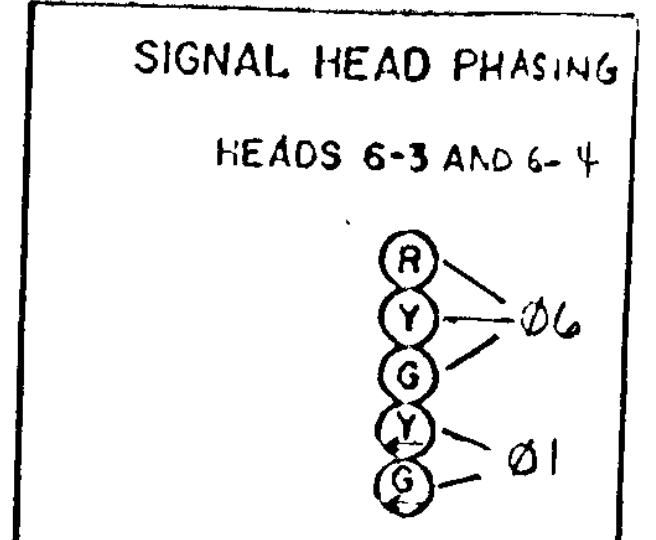

NO.	BY	DATE	REVISIONS	ITEM	DESIGN	CHECKED

I hereby certify that this plan was prepared by me or under my direct supervision and that I am a duly Registered Professional Engineer under the laws of the state of Minnesota.

Date: 3/12/08 Reg. No. 22457

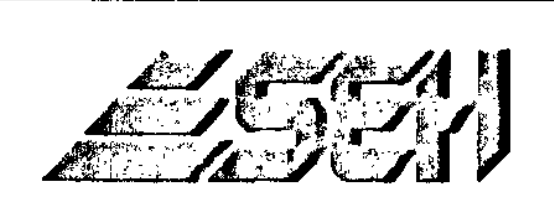

ANOKA COUNTY, MINNESOTA
 CITY OF FRIDLEY
 S.P. 02-601-37
 S.P. 127-020-20

INPLACE SIGNAL SYSTEM "A"
 FOR INFORMATION ONLY
 EAST RIVER ROAD (CSAH 1) AT 77TH WAY NE

FILE NO. ANOKC9708
 DATE 79
 93

NOTES:

- 1) ALL HANDHOLES ARE CONCRETE WITH TYPE "C" COVERS.
- 2) ALL PEDESTRIAN INDICATIONS ARE 9"x 9".
- 3) ALL SIGNAL FACES ARE 12"-3 SECTION R-Y-G, EXCEPT THAT SIGNAL FACES B2, B3, C2 AND C3 12"-4 SECTION R-Y-G-GLTA.

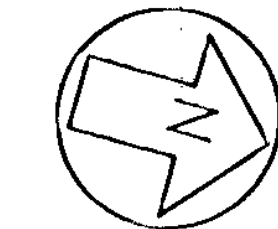

③ WOOD POLE
 2-DOWN GUYS, GUARDS AND ANCHORS
 TYPE 20B MOUNTED AT 270°
 PEDESTRIAN PUSH BUTTON AND SIGN
 JUNCTION BOX
 2" R.S.C. RISER AND WEATHERHEAD ABOVE
 JUNCTION BOX
 2-12/C#12
 1-3/C#12
 3-2/C#14
 1 1/4" R.S.C. RISER BELOW JUNCTION BOX
 INTO HANDHOLE
 3-2/C#14

④ WOOD POLE
 DOWN GUY, GUARD AND ANCHOR
 TYPE 10B MOUNTED AT 0°
 PEDESTRIAN PUSH BUTTON AND SIGN
 JUNCTION BOX
 2" R.S.C. RISER AND WEATHERHEAD ABOVE
 JUNCTION BOX
 1-12/C#12
 1-3/C#12
 1-2/C#14
 1" N.M.C. RISER BELOW JUNCTION BOX
 INTO HANDHOLE
 1-2/C#14

① WOOD POLE
 2-DOWN GUYS, GUARDS AND ANCHORS
 TYPE 20B MOUNTED AT 270°
 PEDESTRIAN PUSH BUTTON AND SIGN
 JUNCTION BOX
 2-2" R.S.C. RISERS AND WEATHERHEADS
 EXTEND INTO CONTROLLER CABINET
 4-12/C#12
 4-3/C#12
 5-2/C#14
 METER AND DISCONNECT-WOOD POLE MOUNTED
 1 1/4" R.S.C. RISER AND WEATHERHEAD ABOVE METER
 1 1/4" R.S.C. RISER BELOW DISCONNECT INTO
 CONTROLLER CABINET

Ⓐ CONTROLLER AND CABINET
 CABINET FOUNDATION
 EXTENDED TO SIGNAL SYSTEM:
 4-12/C#12
 4-3/C#12
 7-2/C#14

② WOOD POLE
 DOWN GUY, GUARD AND ANCHOR
 TYPE 10B MOUNTED AT 270°
 PEDESTRIAN PUSH BUTTON AND SIGN
 JUNCTION BOX
 2" R.S.C. RISER AND WEATHERHEAD ABOVE
 JUNCTION BOX
 1-12/C#12
 1-3/C#12
 1-2/C#14
 1 N.M.C. RISER BELOW JUNCTION BOX
 INTO HANDHOLE
 1-2/C#14

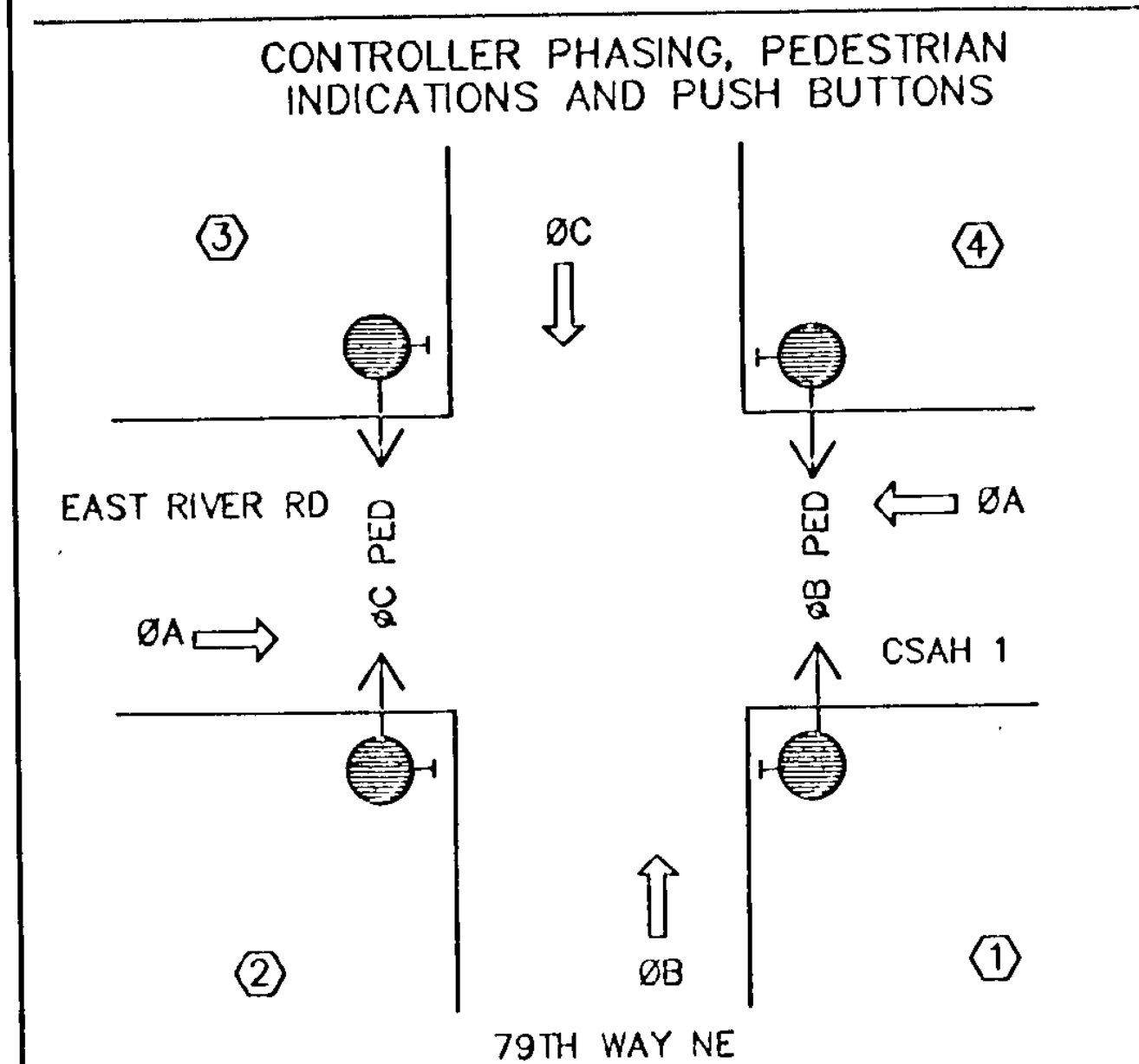
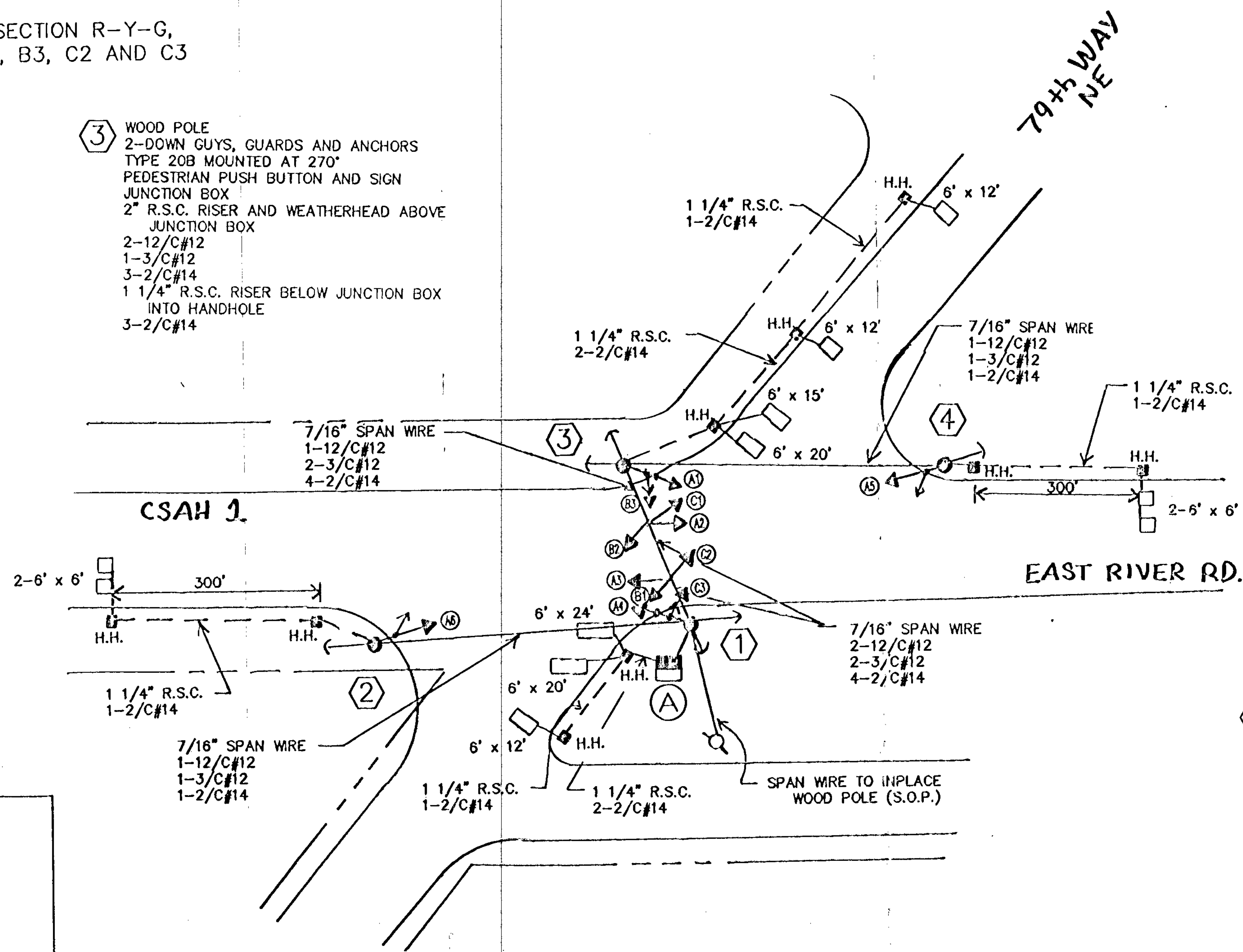

NO.	BY	DATE	REVISIONS	ITEM	DESIGN	CHECKED

I hereby certify that this plan was prepared by me or under my direct supervision and that I am a duly Registered Professional Engineer under the laws of the state of Minnesota.
 Date: 3/10/98 Reg. No. 22457

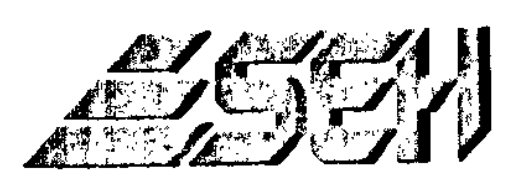

ANOKA COUNTY, MINNESOTA
 CITY OF FRIDLEY
 S.P. 02-601-37
 S.P. 127-020-20

INPLACE SIGNAL SYSTEM "B"
 FOR INFORMATION ONLY
 EAST RIVER ROAD (CSAH 1) AT 79TH WAY NE

FILE NO.
 ANOKC9708
 DATE
 80
 93

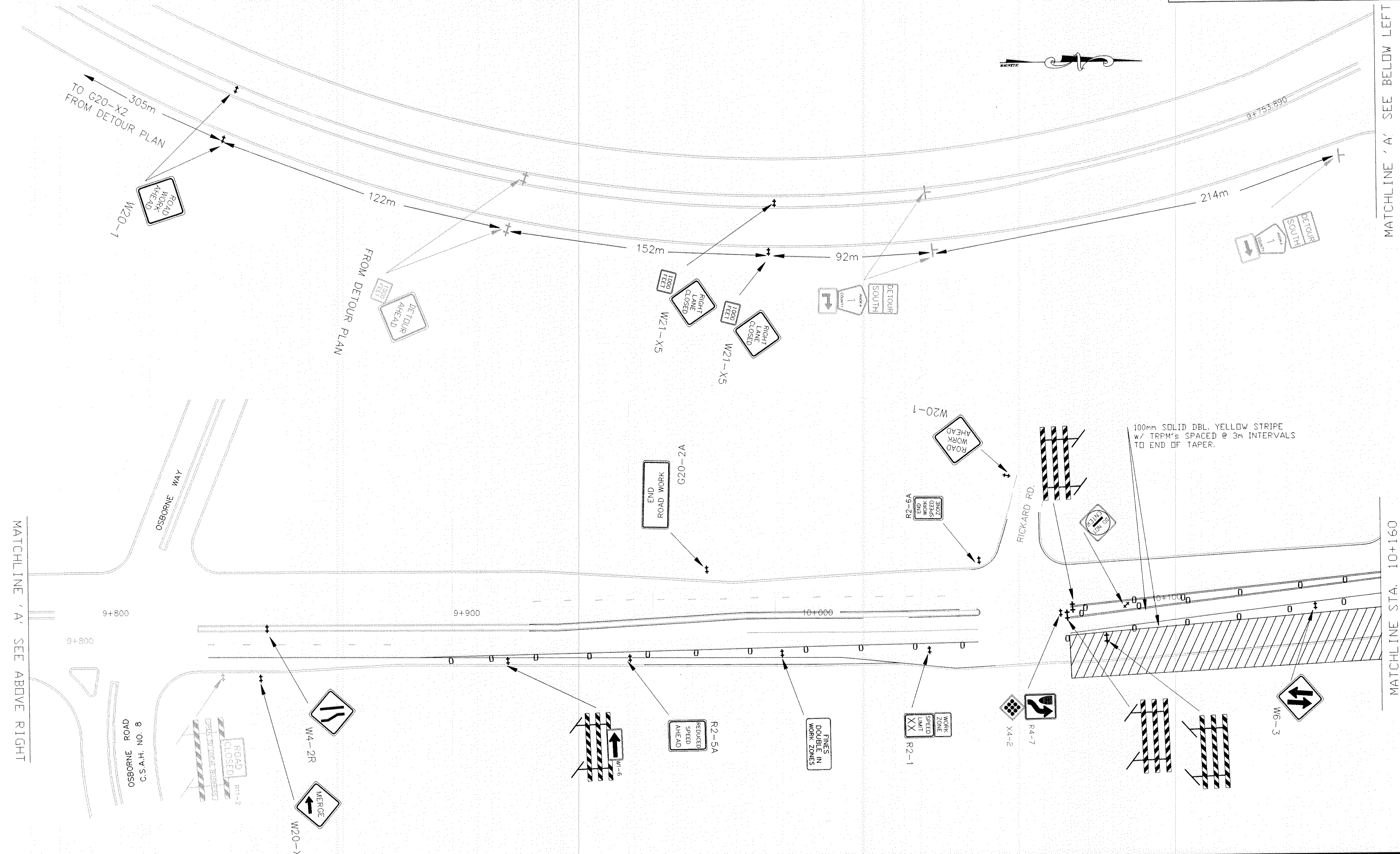

MATCHLINE 'A' SEE ABOVE RIGHT

MATCHLINE 'A' SEE BELOW LEFT

NO	DATE	BY	CKD	APPR	REVISION

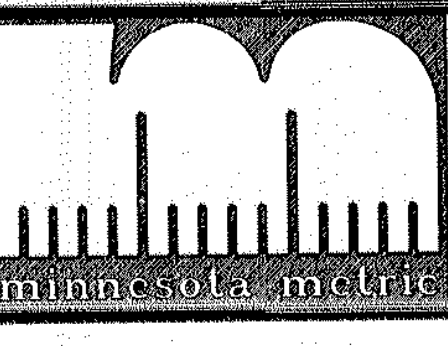

I HEREBY CERTIFY THAT THIS PLAN WAS PREPARED BY ME OR UNDER MY DIRECT SUPERVISION AND THAT I AM A DULY REGISTERED PROFESSIONAL ENGINEER UNDER THE LAWS OF THE STATE OF MINNESOTA.

DATE _____ REG. NO. _____

DRAWN BY: D. M. DATE: 5/98
 DESIGN BY: _____ DATE: _____
 CHECKED BY: _____ DATE: _____

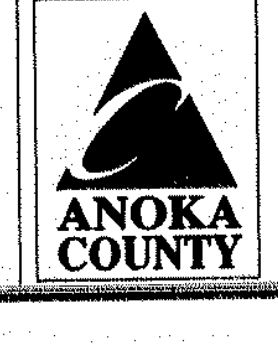

ANOKA COUNTY
 HIGHWAY DEPT.

STATE PROJECT NO. 02-601-37
 STATE AID PROJECT NO. 127-020-20
 STATE AID PROJECT NO. 114-020-18
 COUNTY PROJECT NO. _____

STAGE 2
 550mm BEFORE PROJECT
 TO STA. 10+160
 Sheet 81 of 93 Sheets

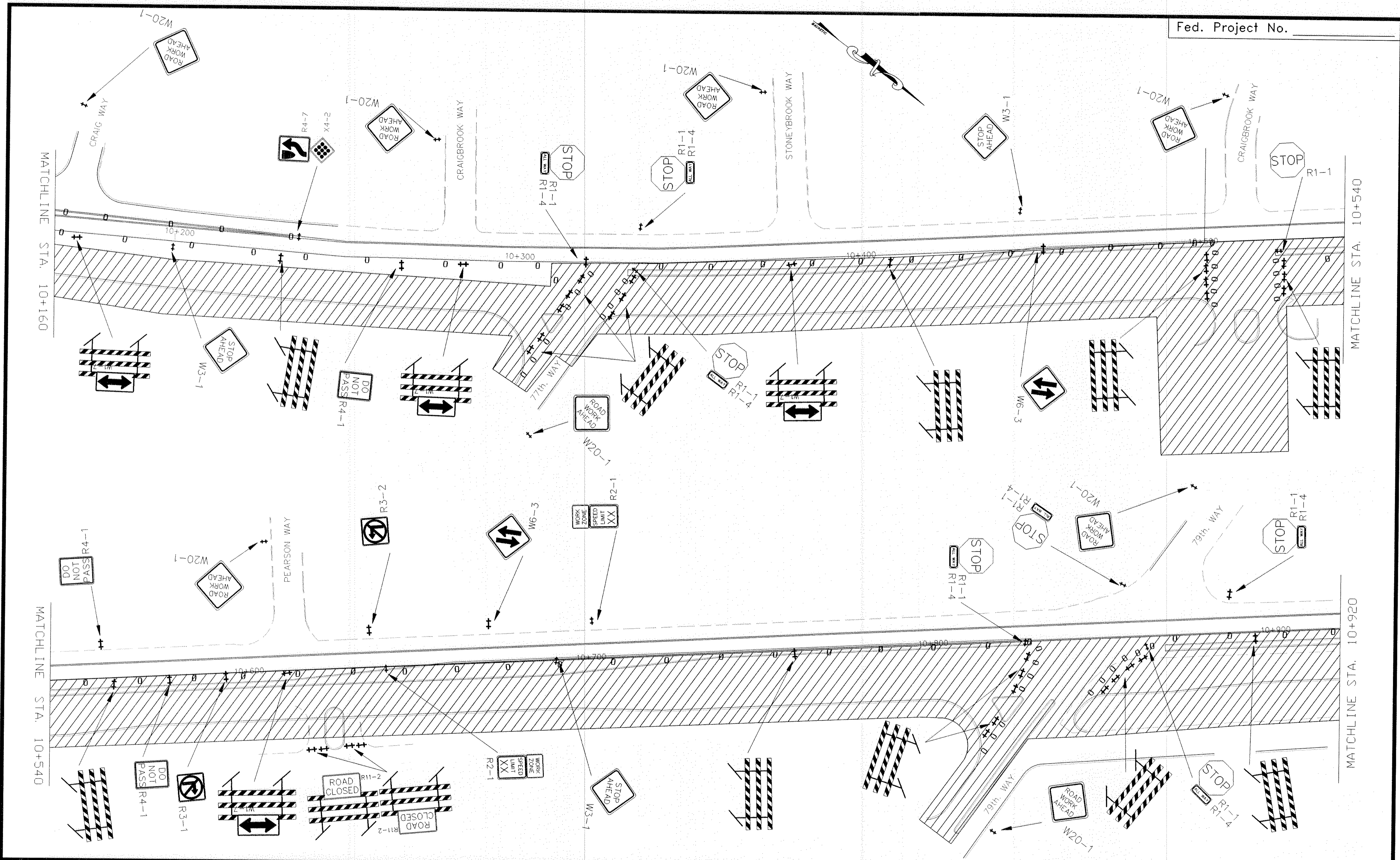

NO	DATE	BY	CKD	APPR	REVISION

NAME: S:\SDSKPROJ\000000\000000\026000.DWG

I HEREBY CERTIFY THAT THIS PLAN WAS PREPARED BY ME OR UNDER MY DIRECT SUPERVISION AND THAT I AM A DULY REGISTERED PROFESSIONAL ENGINEER UNDER THE LAWS OF THE STATE OF MINNESOTA.

DATE _____ REG. NO. _____

DRAWN BY: D. M. DATE: 5/98
 DESIGN BY: _____ DATE: _____
 CHECKED BY: _____ DATE: _____



ANOKA COUNTY
 HIGHWAY DEPT.

STATE PROJECT NO. 02-601-37
 STATE AID PROJECT NO. 127-020-20
 STATE AID PROJECT NO. 114-020-18
 COUNTY PROJECT NO. _____

STAGE 2
 STA. 10+160 TO STA. 10+920
 Sheet 82 of 93 Sheets

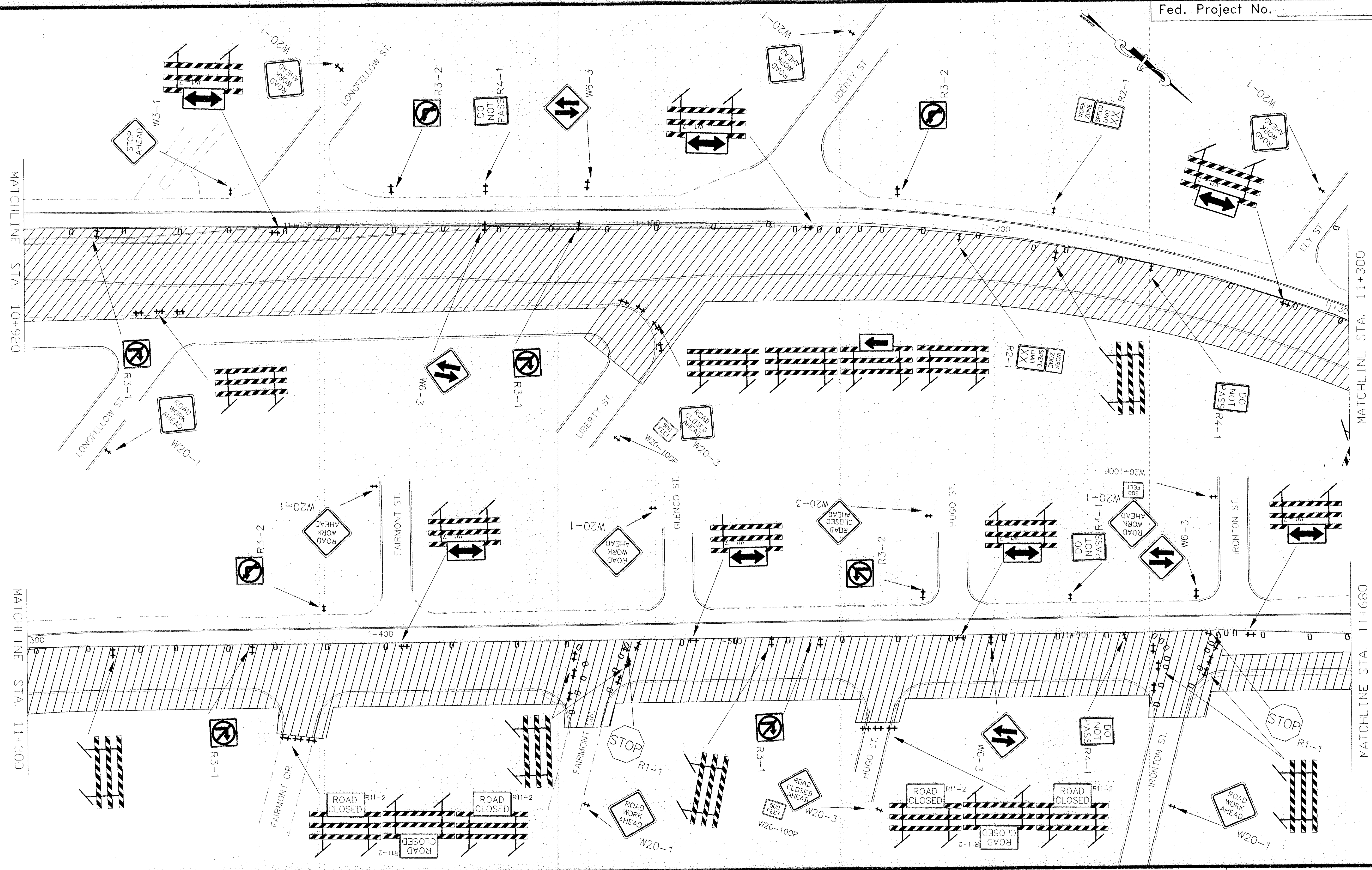

NO	DATE	BY	CKD	APPR	REVISION



I HEREBY CERTIFY THAT THIS PLAN WAS PREPARED BY ME OR UNDER MY DIRECT SUPERVISION AND THAT I AM A DULY REGISTERED PROFESSIONAL ENGINEER UNDER THE LAWS OF THE STATE OF MINNESOTA.

DATE _____ REG. NO. _____

DRAWN BY: D. M. DATE: 5/98
 DESIGN BY: _____ DATE: _____
 CHECKED BY: _____ DATE: _____



ANOKA COUNTY
HIGHWAY DEPT.

STATE PROJECT NO. 02-601-37
 STATE AID PROJECT NO. 127-020-20
 STATE AID PROJECT NO. 114-020-18
 COUNTY PROJECT NO. _____

STAGE 2
 STA. 10+920 TO STA. 11+680
 Sheet 83 of 93 Sheets

BEGIN 100mm SOLID WHITE TAPER STRIPE w/TRPM's SPACED @ 3m INTERVALS

BEGIN REMOVAL WHITE SKIP STRIPE

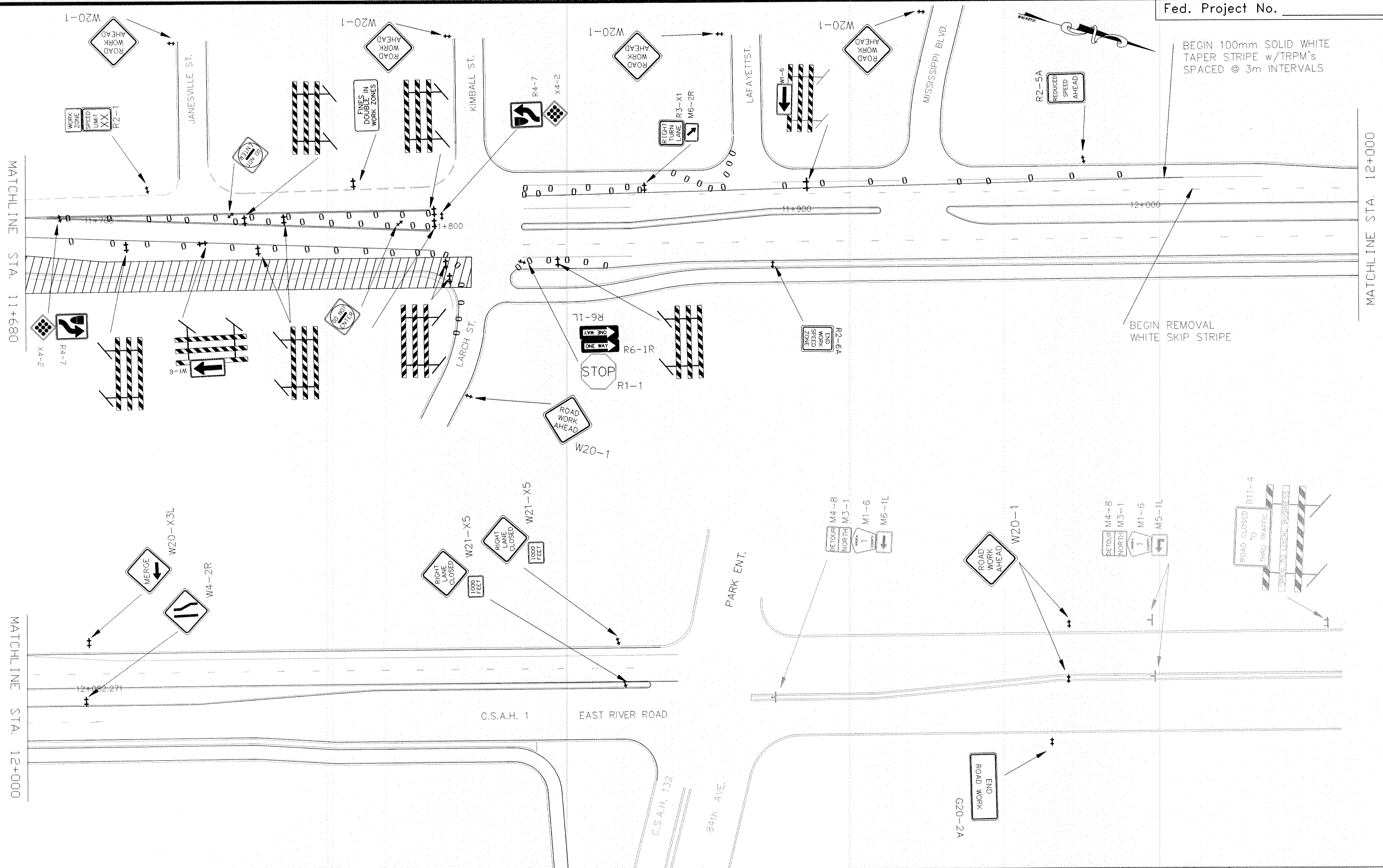

MATCHLINE STA. 11+680

MATCHLINE STA. 12+000

MATCHLINE STA. 12+000

NO	DATE	BY	CKD	APPR	REVISION

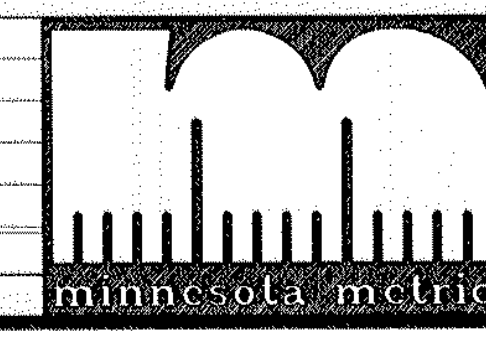

I HEREBY CERTIFY THAT THIS PLAN WAS PREPARED BY ME OR UNDER MY DIRECT SUPERVISION AND THAT I AM A DULY REGISTERED PROFESSIONAL ENGINEER UNDER THE LAWS OF THE STATE OF MINNESOTA.

DATE _____ REG. NO. _____

DRAWN BY: D. M. DATE: 5/98
 DESIGN BY: _____ DATE: _____
 CHECKED BY: _____ DATE: _____

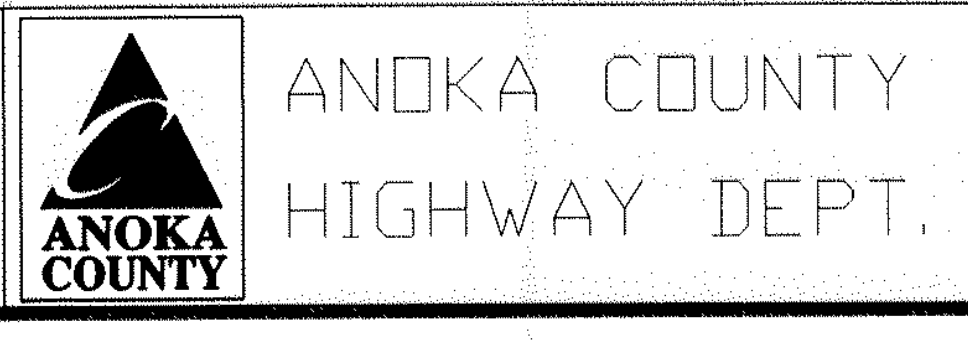

STATE PROJECT NO. 02-601-37
 STATE AID PROJECT NO. 127-020-20
 STATE AID PROJECT NO. 114-020-18
 COUNTY PROJECT NO. _____

STAGE 2
 STA. 11+680 TO 550mm BEYOND PROJECT
 Sheet 84 of 93 Sheets

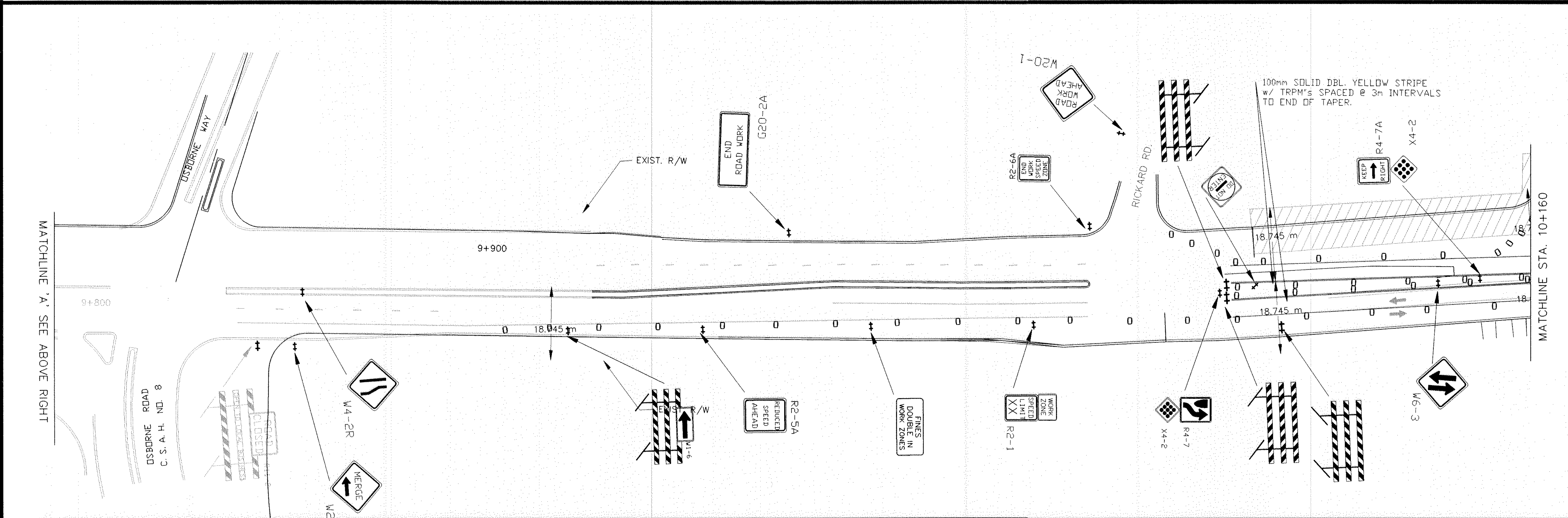
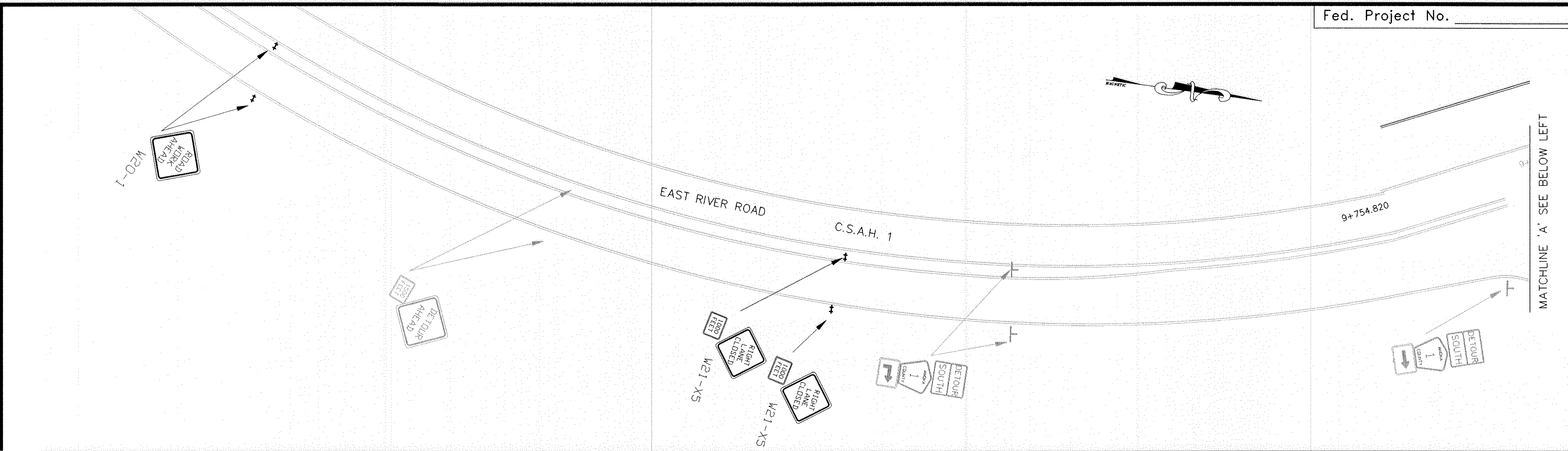

NO	DATE	BY	CKD	APPR	REVISION

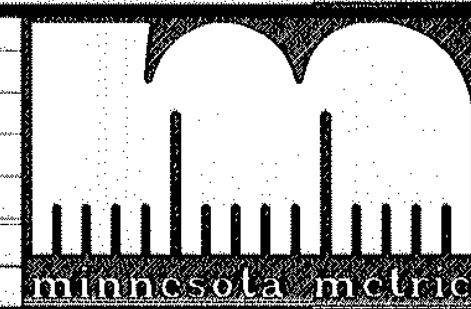

I HEREBY CERTIFY THAT THIS PLAN WAS PREPARED BY ME OR UNDER MY DIRECT SUPERVISION AND THAT I AM A DULY REGISTERED PROFESSIONAL ENGINEER UNDER THE LAWS OF THE STATE OF MINNESOTA.

DATE _____ REG. NO. _____

DRAWN BY D.M. DATE 5/98
 DESIGN BY _____ DATE _____
 CHECKED BY _____ DATE _____

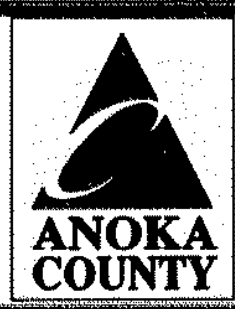

ANOKA COUNTY
HIGHWAY DEPT.

STATE PROJECT NO. 02-601-37
 STATE AID PROJECT NO. 127-020-20
 STATE AID PROJECT NO. 114-020-18
 COUNTY PROJECT NO. _____

STAGE 3
 550m IN ADVANCE OF
 PROJECT TO STA. 10+160
 Sheet 85 of 93 Sheets

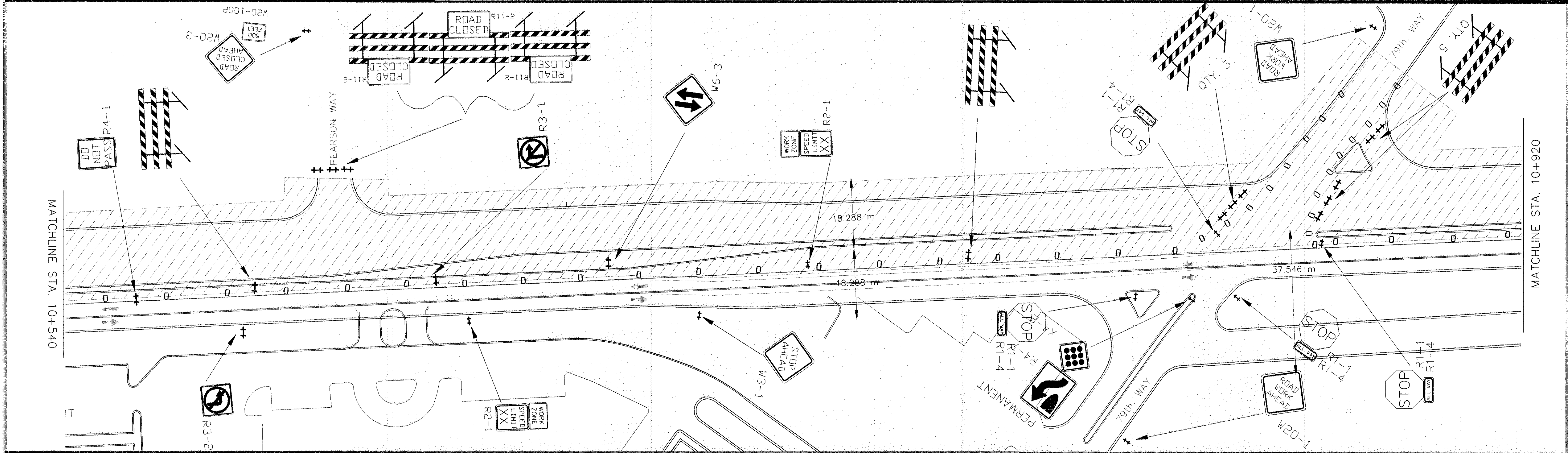
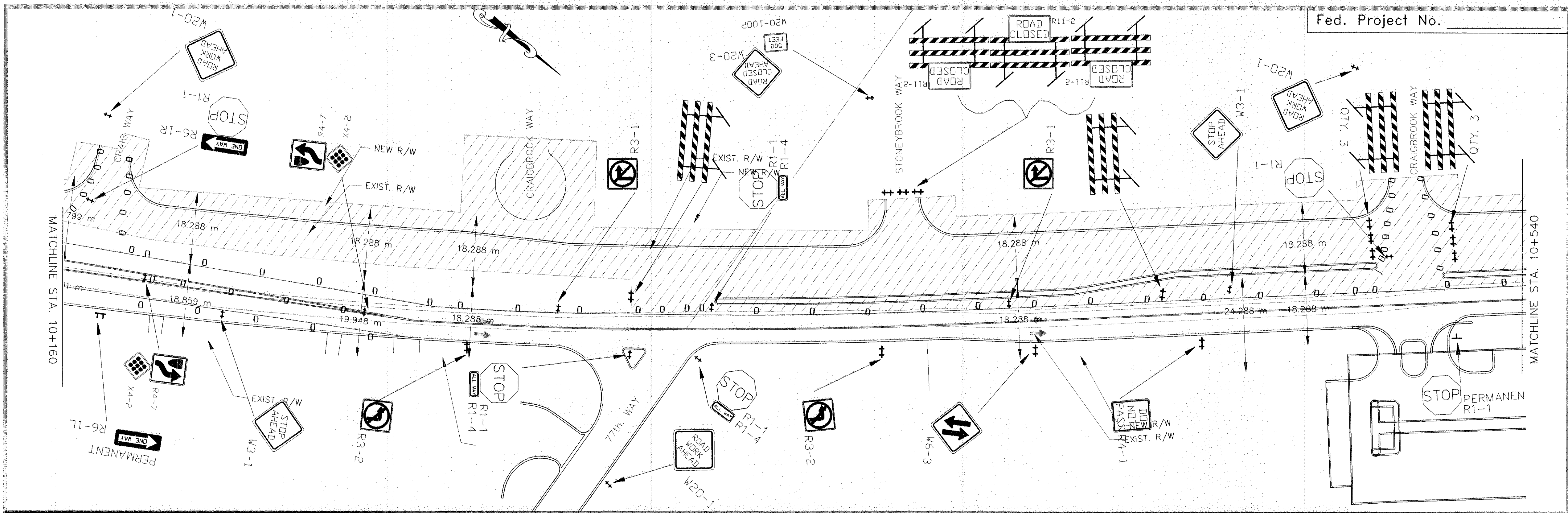

NO	DATE	BY	CKD	APPR	REVISION
NAME: S:\SDSKPRD\J\000000\000000\026000.DWG					

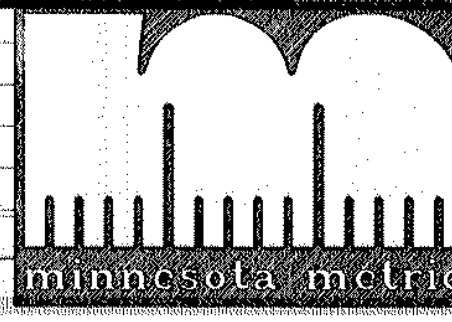

I HEREBY CERTIFY THAT THIS PLAN WAS PREPARED BY ME OR UNDER MY DIRECT SUPERVISION AND THAT I AM A DULY REGISTERED PROFESSIONAL ENGINEER UNDER THE LAWS OF THE STATE OF MINNESOTA.

DATE _____ REG. NO. _____

DRAWN BY D.M. DATE 5/98
 DESIGN BY _____ DATE _____
 CHECKED BY _____ DATE _____

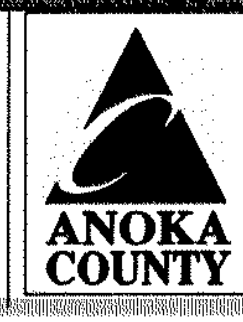

ANOKA COUNTY
HIGHWAY DEPT.

STATE PROJECT NO. 02-601-37
 STATE AID PROJECT NO. 127-020-20
 STATE AID PROJECT NO. 114-020-18
 COUNTY PROJECT NO. _____

STAGE 3
 STA 10+160 TO 10+920
 Sheet 86 of 93 Sheets

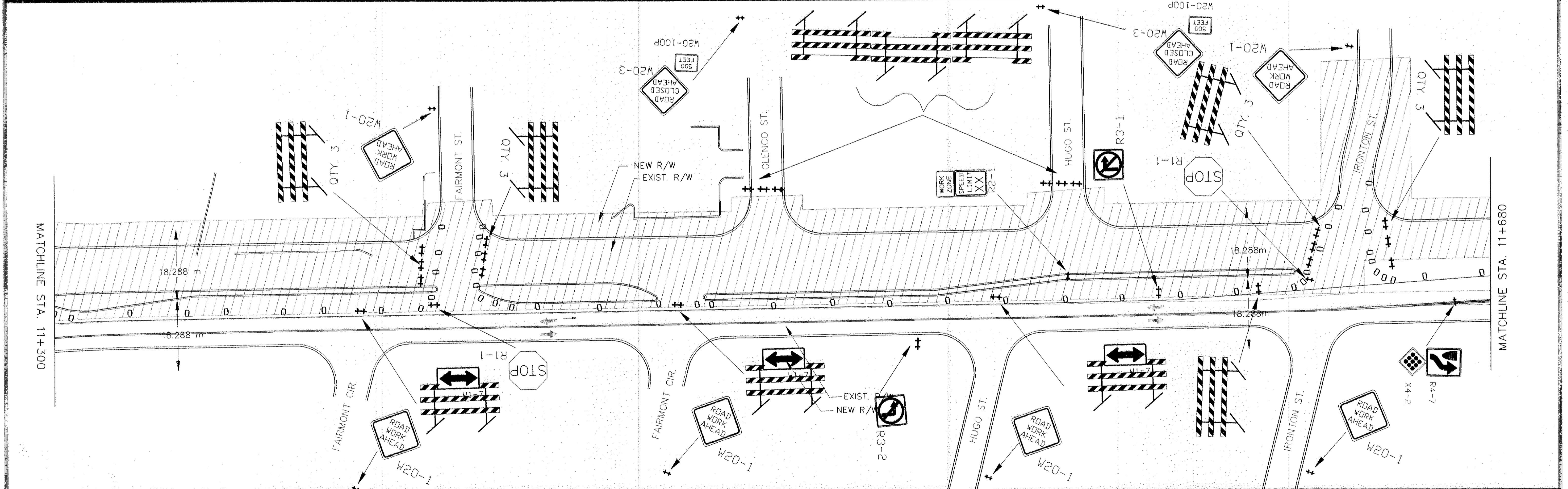
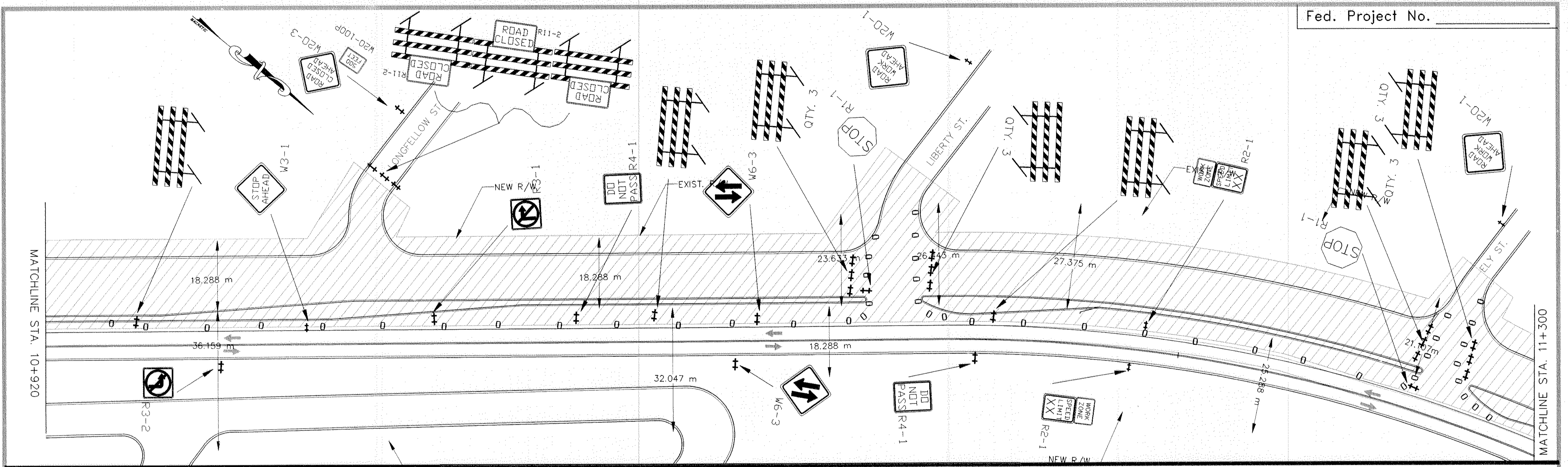

NO	DATE	BY	CKD	APPR	REVISION

NAME: S:\SDSKPRD\J\000000\000000\026000.DWG

I HEREBY CERTIFY THAT THIS PLAN WAS PREPARED BY ME OR UNDER MY DIRECT SUPERVISION AND THAT I AM A DULY REGISTERED PROFESSIONAL ENGINEER UNDER THE LAWS OF THE STATE OF MINNESOTA.

DATE _____ REG. NO. _____

DRAWN BY: D.M. DATE: 5/98

DESIGN BY: _____ DATE: _____

CHECKED BY: _____ DATE: _____

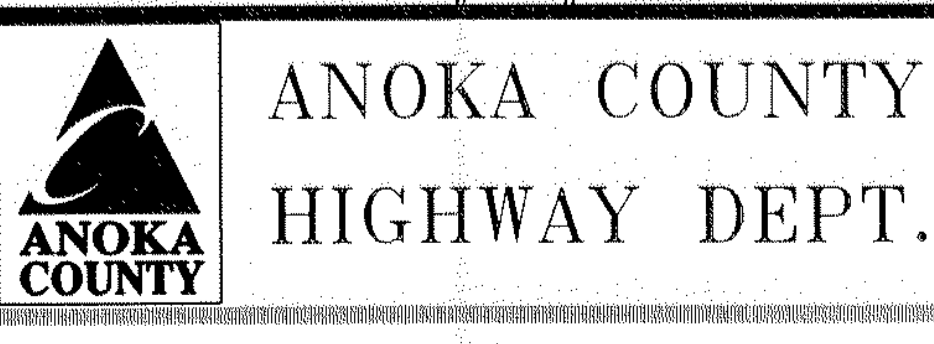

STATE PROJECT NO. 02-601-37

STATE AID PROJECT NO. 127-020-20

STATE AID PROJECT NO. 114-020-18

COUNTY PROJECT NO. _____

STAGE 3

STA 10+920 TO 11+680

Sheet 87 of 93 Sheets

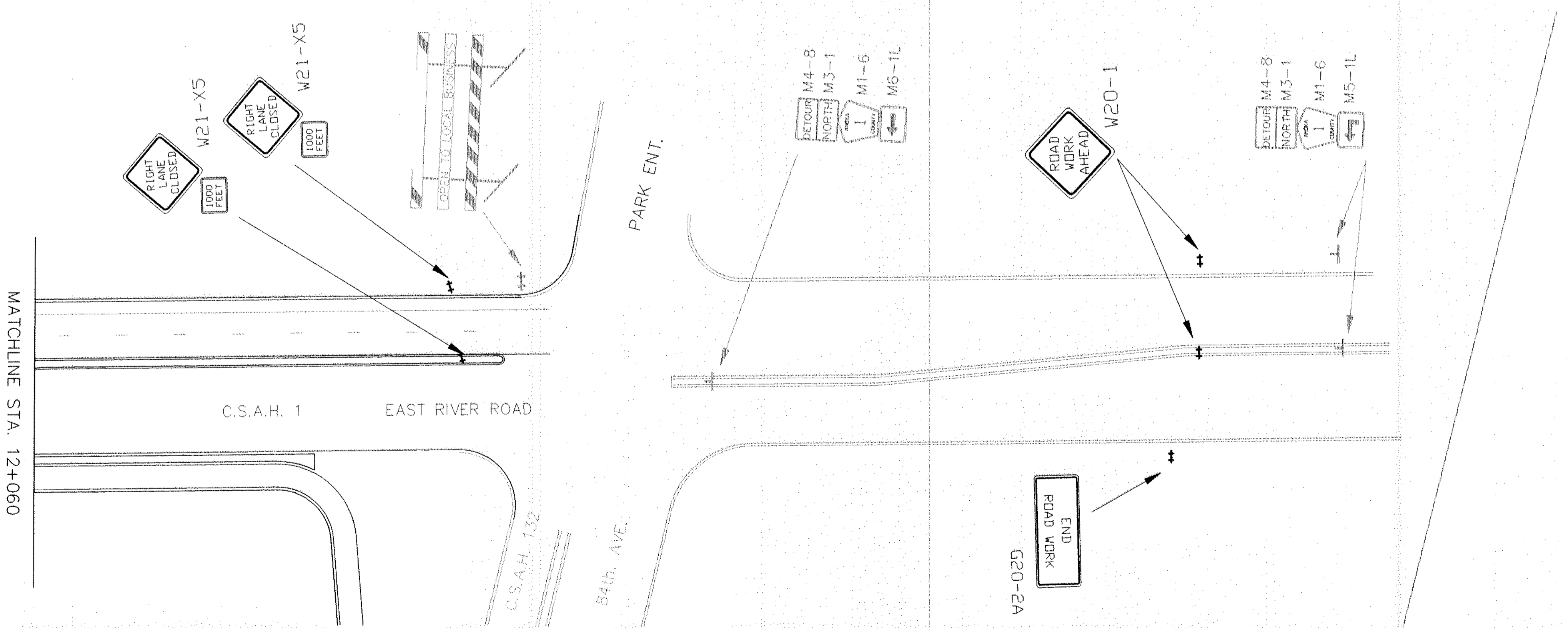
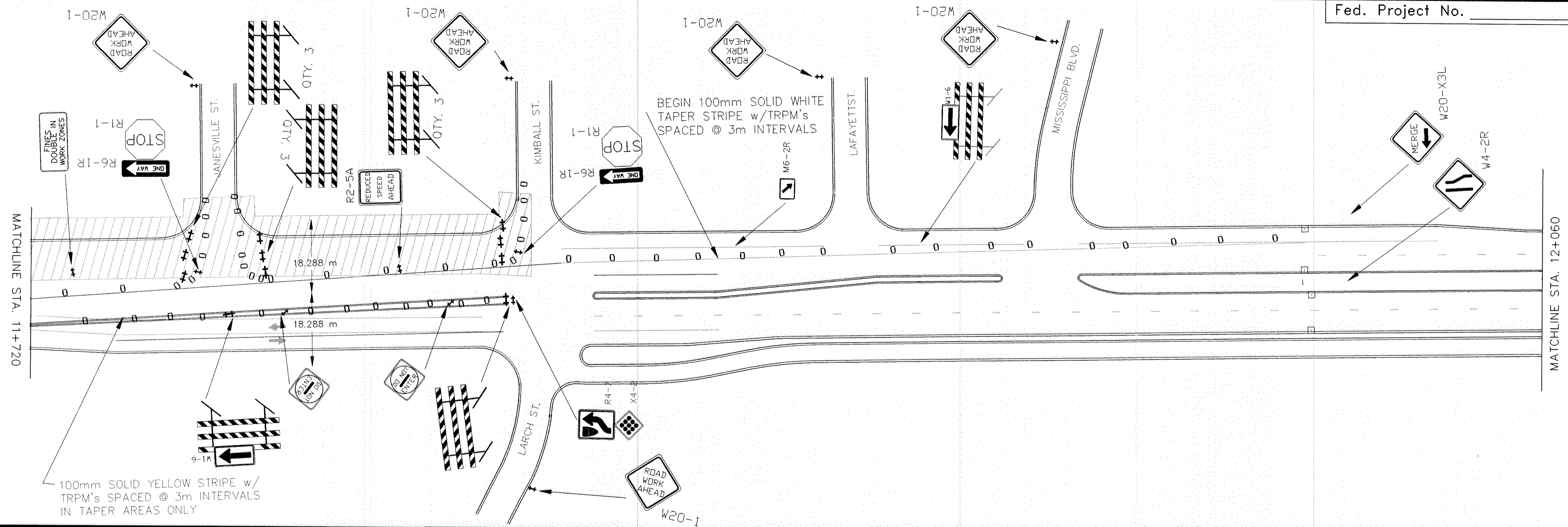

NO	DATE	BY	CKD	APPR	REVISION

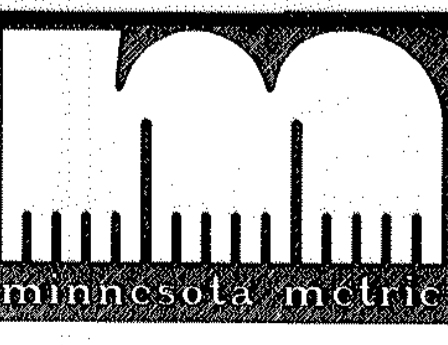

I HEREBY CERTIFY THAT THIS PLAN WAS PREPARED BY ME OR UNDER MY DIRECT SUPERVISION AND THAT I AM A DULY REGISTERED PROFESSIONAL ENGINEER UNDER THE LAWS OF THE STATE OF MINNESOTA.

DATE _____ REG. NO. _____

DRAWN BY D.M. DATE 5/98
 DESIGN BY _____ DATE _____
 CHECKED BY _____ DATE _____

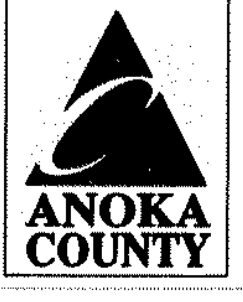

ANOKA COUNTY HIGHWAY DEPT.

STATE PROJECT NO. 02-601-37
 STATE AID PROJECT NO. 127-020-20
 STATE AID PROJECT NO. 114-020-18
 COUNTY PROJECT NO. _____

STAGE 3
 STA. 11+680 TO 550m BEYOND PROJECT
 Sheet 88 of 93 Sheets

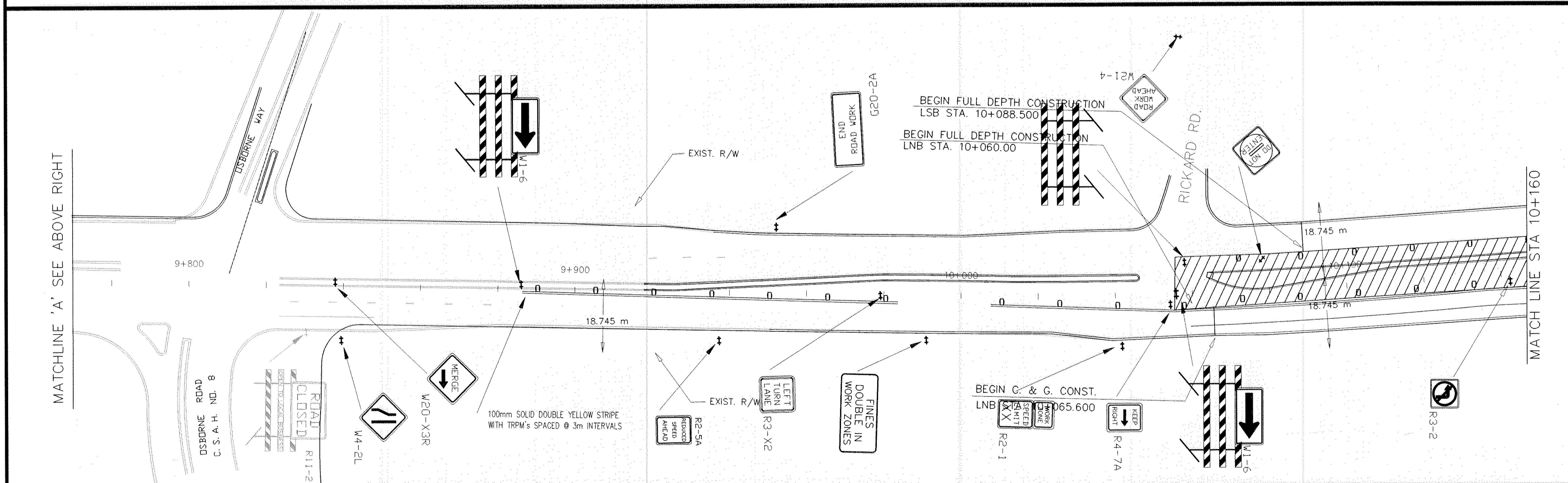
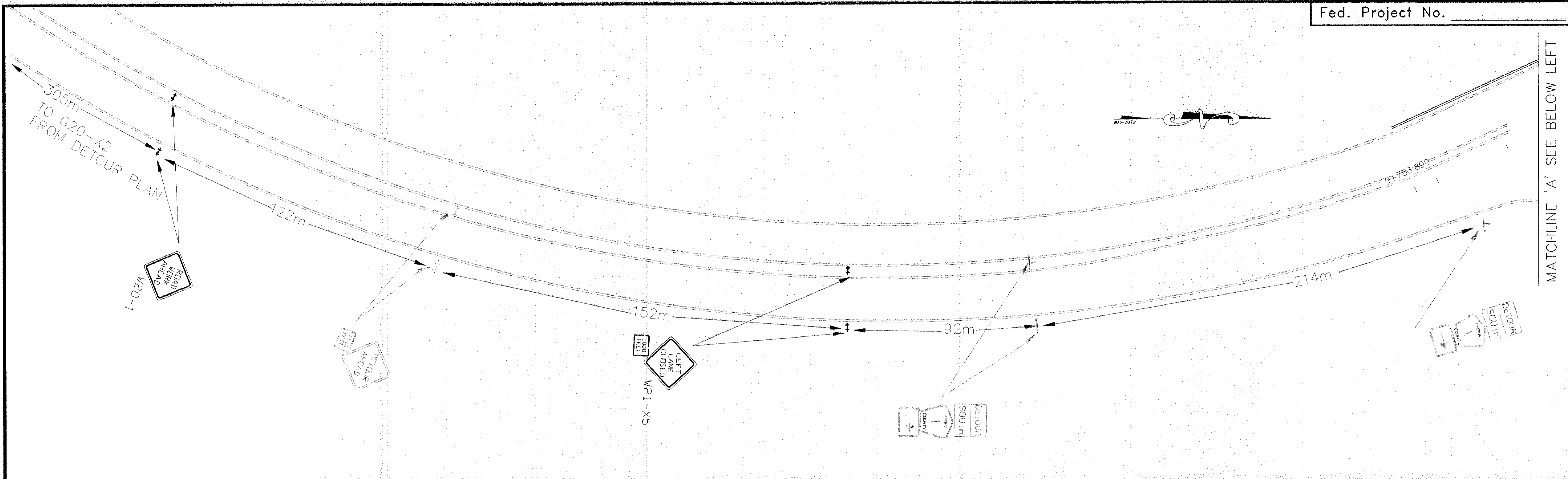

NO	DATE	BY	CKD	APPR	REVISION

NAME: S:\SPSKPROJ\000000\000000\026000.DWG

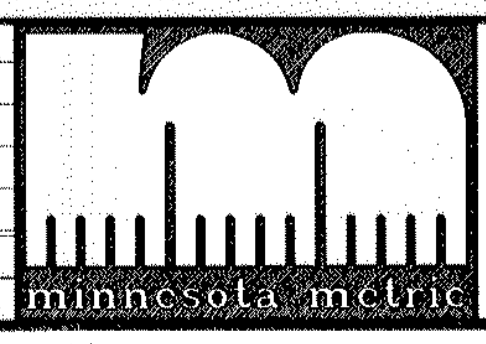

I HEREBY CERTIFY THAT THIS PLAN WAS PREPARED BY ME OR UNDER MY DIRECT SUPERVISION AND THAT I AM A DULY REGISTERED PROFESSIONAL ENGINEER UNDER THE LAWS OF THE STATE OF MINNESOTA.

DATE _____ REG. NO. _____

DRAWN BY: DM DATE: 5/98
 DESIGN BY: _____ DATE: _____
 CHECKED BY: _____ DATE: _____

ANOKA COUNTY
HIGHWAY DEPT.

STATE PROJECT NO. 02-601-37
 STATE AID PROJECT NO. 127-020-20
 STATE AID PROJECT NO. 114-0202-18
 COUNTY PROJECT NO. _____

STAGE 4
 550m BEFORE PROJECT
 TO STA. 10+160
 Sheet 89 of 93 Sheets

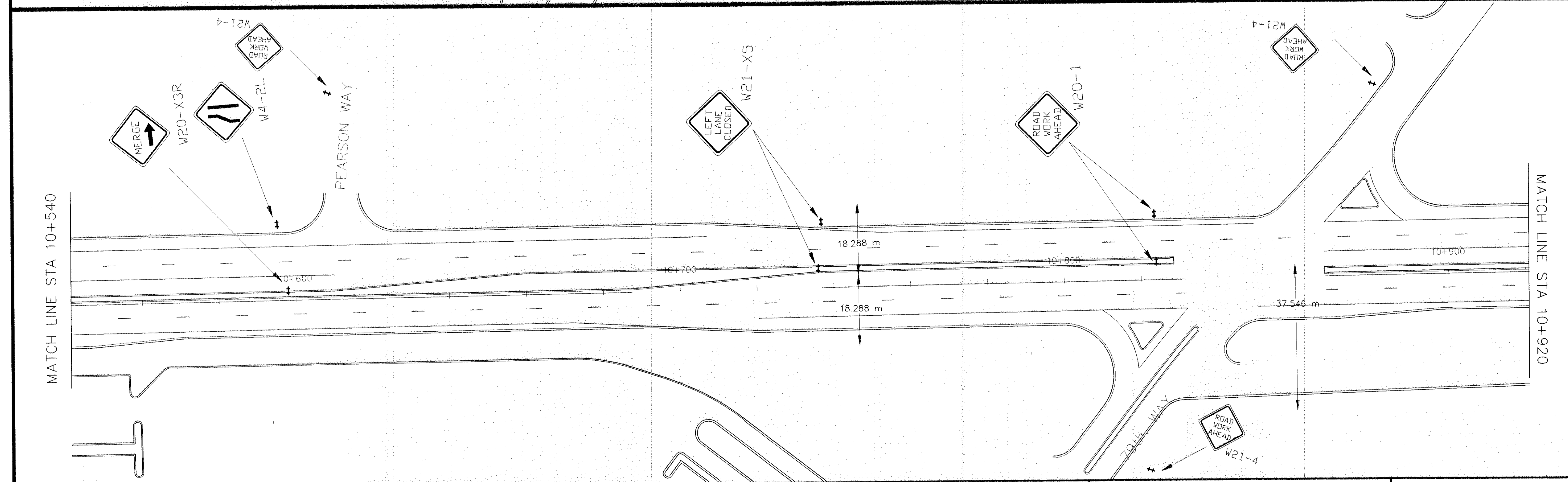
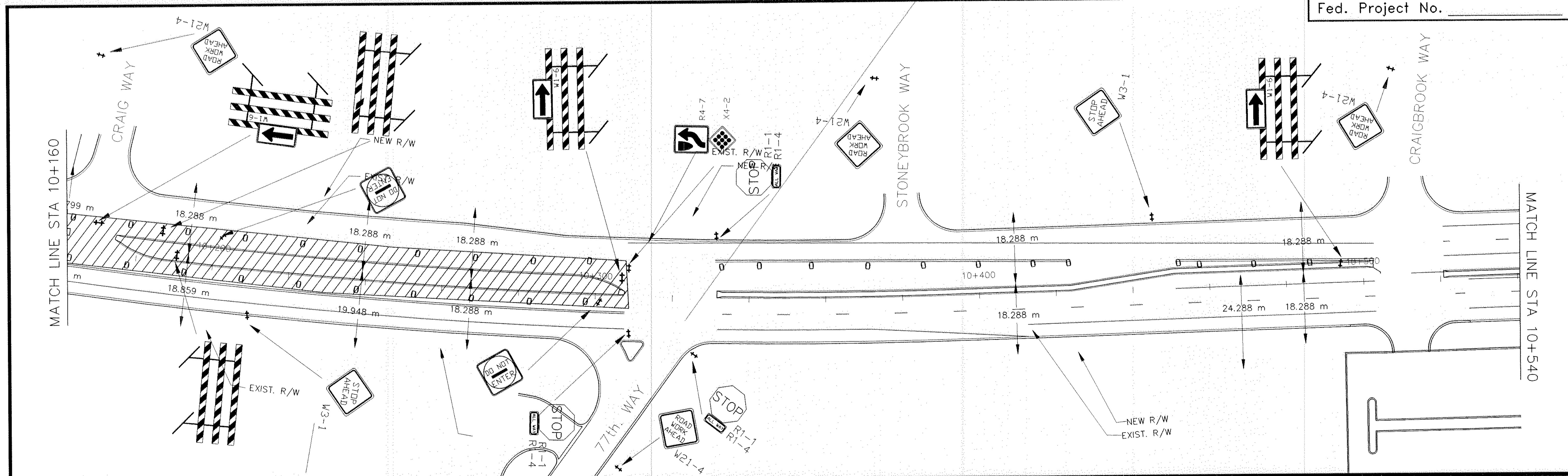

NO	DATE	BY	CKD	APPR	REVISION

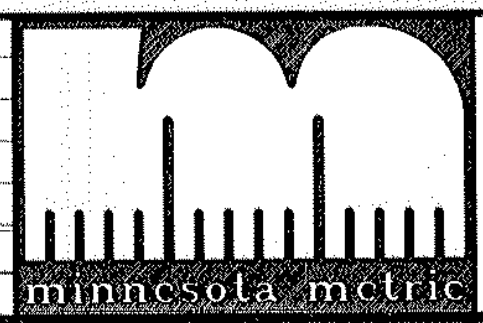

I HEREBY CERTIFY THAT THIS PLAN WAS PREPARED BY ME OR UNDER MY DIRECT SUPERVISION AND THAT I AM A DULY REGISTERED PROFESSIONAL ENGINEER UNDER THE LAWS OF THE STATE OF MINNESOTA.

DATE _____ REG. NO. _____

DRAWN BY: DM DATE: 5/98
 DESIGN BY: _____ DATE: _____
 CHECKED BY: _____ DATE: _____



ANOKA COUNTY
HIGHWAY DEPT.

STATE PROJECT NO. 02-601-37
 STATE AID PROJECT NO. 127-020-20
 STATE AID PROJECT NO. 114-0202-18
 COUNTY PROJECT NO. _____

STAGE 4
 STA 10+160 TO 10+920
 Sheet 90 of 93 Sheets

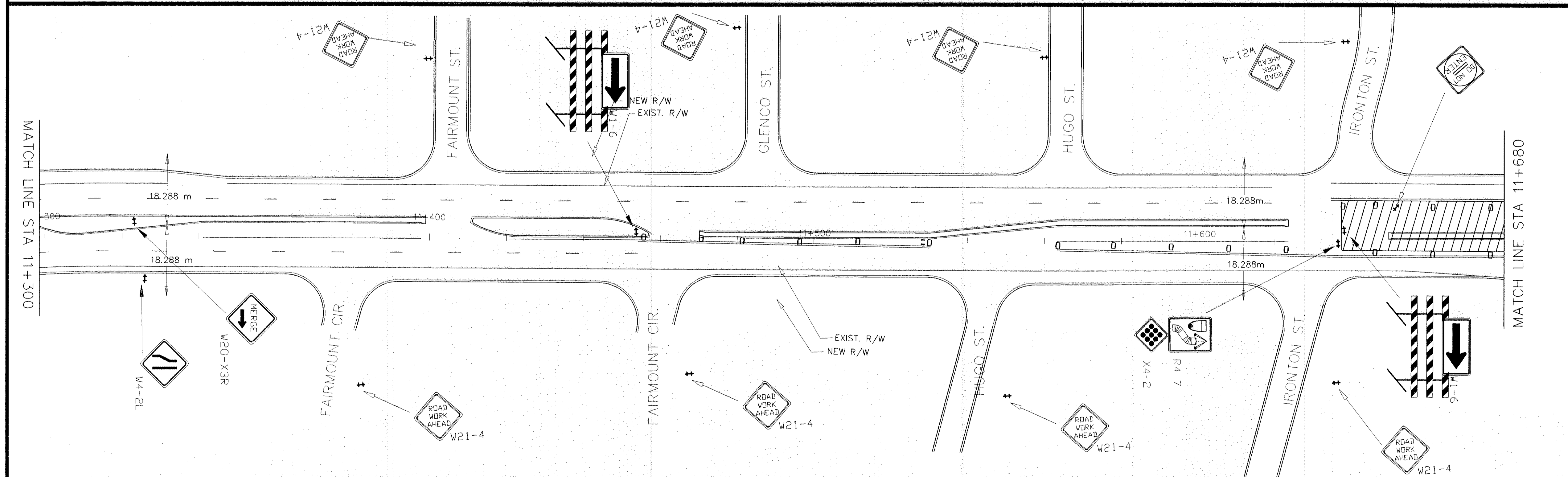
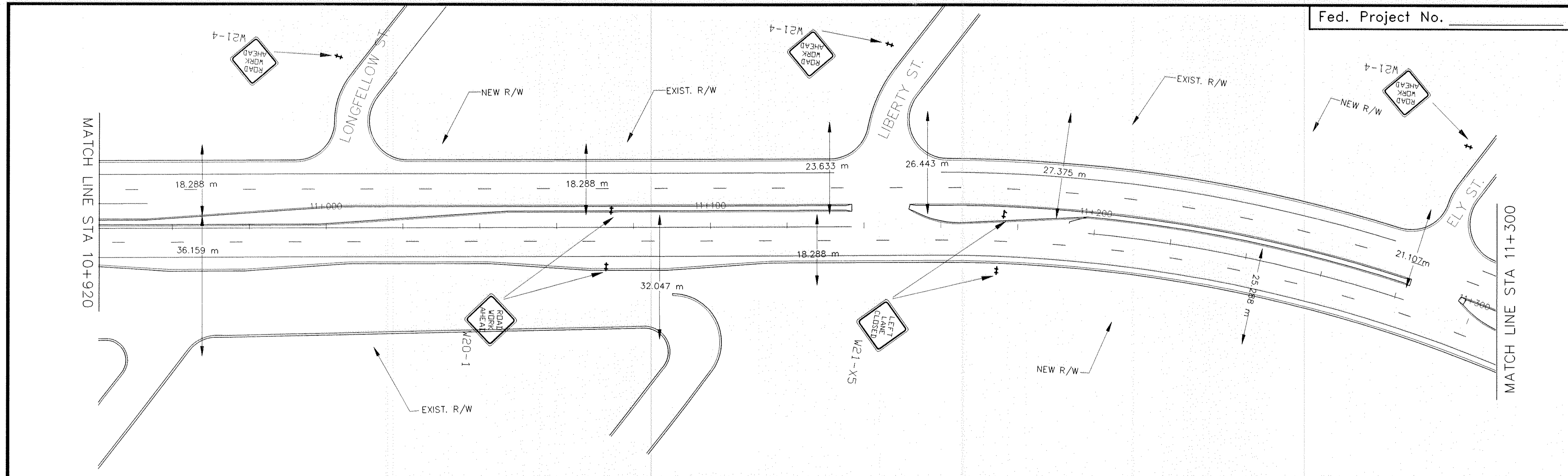

NO	DATE	BY	CKD	APPR	REVISION

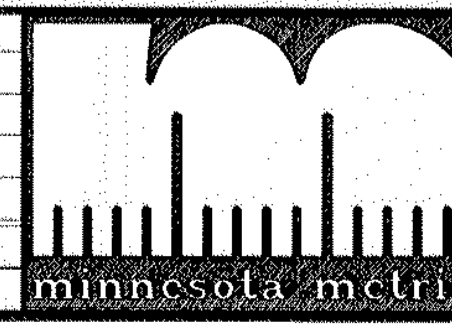

I HEREBY CERTIFY THAT THIS PLAN WAS PREPARED BY ME OR UNDER MY DIRECT SUPERVISION AND THAT I AM A DULY REGISTERED PROFESSIONAL ENGINEER UNDER THE LAWS OF THE STATE OF MINNESOTA.

DATE _____ REG. NO. _____

DRAWN BY: DM DATE: 5/98
 DESIGN BY: _____ DATE: _____
 CHECKED BY: _____ DATE: _____



ANOKA COUNTY
HIGHWAY DEPT.

STATE PROJECT NO. 02-601-37
 STATE AID PROJECT NO. 127-020-20
 STATE AID PROJECT NO. 114-0202-18
 COUNTY PROJECT NO. _____

STAGE 4
 STA 10+920 TO 11+680
 Sheet 91 of 93 Sheets

NAME: S:\SDSKPROJ\000000\000000\026000.DWG

Fed. Project No. _____

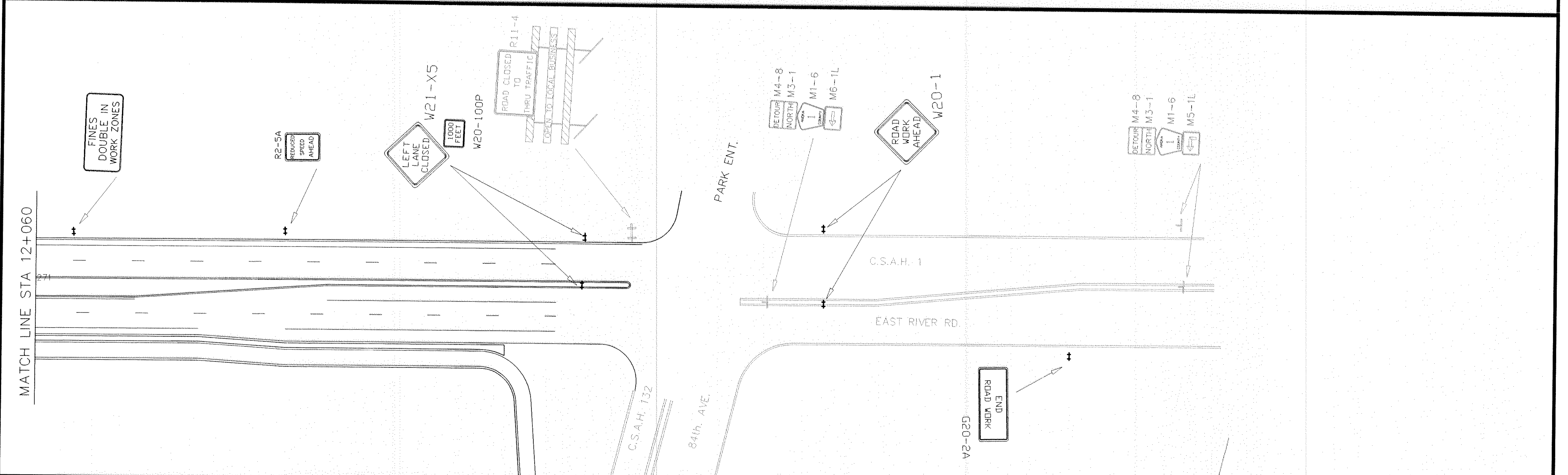
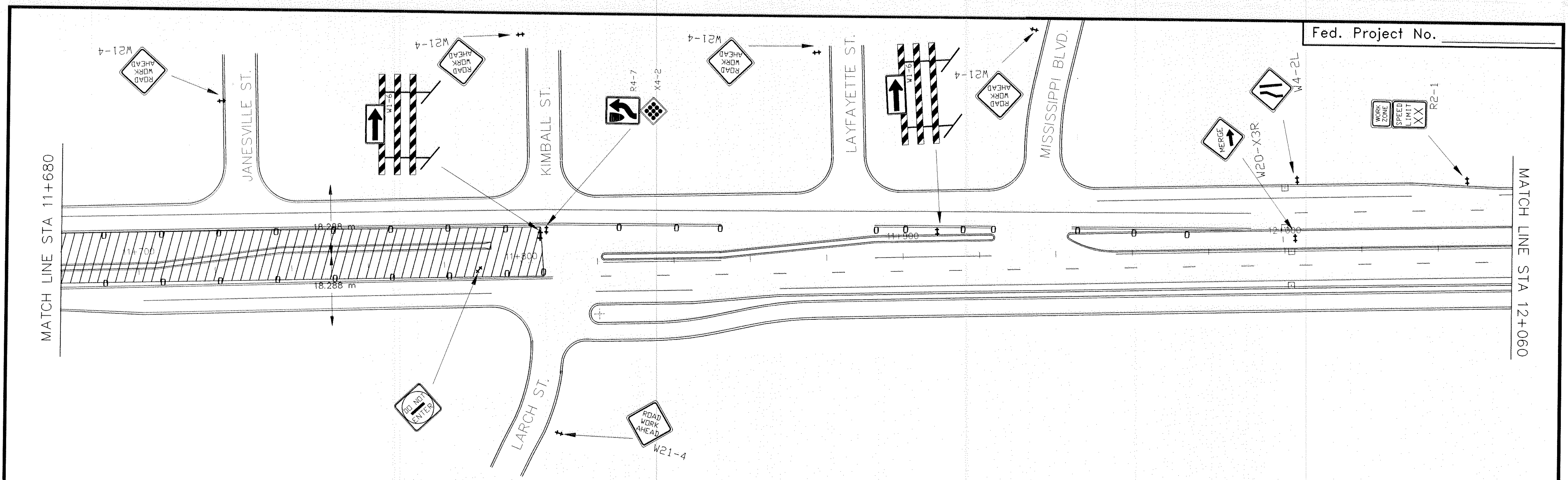

NO	DATE	BY	CKD	APPR	REVISION

I HEREBY CERTIFY THAT THIS PLAN WAS PREPARED BY ME OR UNDER MY DIRECT SUPERVISION AND THAT I AM A DULY REGISTERED PROFESSIONAL ENGINEER UNDER THE LAWS OF THE STATE OF MINNESOTA.

DATE _____ REG. NO. _____

DRAWN BY: DM DATE: 5/98
 DESIGN BY: _____ DATE: _____
 CHECKED BY: _____ DATE: _____



ANOKA COUNTY
HIGHWAY DEPT.

STATE PROJECT NO. 02-601-37
 STATE AID PROJECT NO. 127-020-20
 STATE AID PROJECT NO. 114-0202-18
 COUNTY PROJECT NO. _____

STAGE 4
 STA 11+680 TO
 550m BEYOND PROJECT
 Sheet 92 of 93 Sheets

M. U. T. C. D. CODE	SIZE	INSERT	STAGE II	STAGE III	STAGE IV
			QTY	QTY	QTY
R1-1	48" x 48"	STOP	• 13	• 15	• 3
R1-4	18" x 6"		• 7	• 7	• 3
R2-1	24" x 30"	SPEED LIMIT XX	• 6	• 5	• 2
R2-5A	24" x 30"	REDUCE SPEED AHEAD	• 2	• 2	• 1
R2-6A	24" x 30"	END WORK SPEED ZONE	• 2	• 1	• 0
R2-X6P	24" x 18"	WORK ZONE	• 6	• 5	• 2
R3-1	24" x 24"		• 5	• 5	• 0
R3-2	24" x 24"		• 5	• 5	• 1
R3-X1	30" x 30"	RIGHT TURN LANE	• 1	• 1	• 0
R3-X2	30" x 30"	LEFT TURN LANE	• 0	• 0	• 1
R4-1	24" x 30"	DO NOT PASS	• 7	• 4	• 0
R4-7	24" x 30"		• 4	• 6	• 4
R5-1	30" x 30"	NO NO U-TURN	• 3	• 3	• 5
R6-1R	36" x 12"	ONE WAY	• 1	• 2	• 0
R6-1L	36" x 12"	ONE WAY	• 1	• 2	• 0
R11-2	48" x 30"	ROAD CLOSED	• 8	• 15	• 0
TYPE III L	8 FT.		• 21	• 4	• 12
TYPE III R	8 FT.		• 64	• 76	• 0
W1-6	48" x 24"		• 3	• 2	• 9
W1-7	48" x 24"		• 11	• 3	• 0

M. U. T. C. D. CODE	SIZE	INSERT	STAGE II	STAGE III	STAGE IV
			QTY	QTY	QTY
W3-1a	48" x 48"		• 4	• 4	• 2
W4-2L	48" x 48"		• 0	• 0	• 4
W4-2R	48" x 48"		• 2	• 2	• 0
W6-3	48" x 48"		• 7	• 5	• 0
W20-1	48" x 48"	ROAD WORK AHEAD	• 28	• 23	• 31
W20-100P	24" x 18"	500 FEET	• 3	• 5	• 0
W20-100P	24" x 18"	1000 FEET	• 4	• 4	• 31
W20-3	48" x 48"	ROAD CLOSED AHEAD	• 3	• 5	• 0
W20-X3L	48" x 48"	MERGE	• 2	• 2	• 0
W20-X3R	48" x 48"	MERGE	• 0	• 0	• 4
W21-X5R	48" x 48"	RIGHT LANE CLOSED	• 4	• 3	• 0
W21-X5R	48" x 48"	LEFT LANE CLOSED	• 0	• 0	• 8
X4-2	18" x 18"		• 4	• 6	• 4
M6-2R	21" x 15"		• 1	• 1	• 0
G20-2A	48" x 24"	END ROAD WORK	• 2	• 2	• 2

M. U. T. C. D. CODE	SIZE	INSERT	STAGE II	STAGE III	STAGE IV
			QTY	QTY	QTY
R16-X14	66" x 36"	FINES DOUBLE IN WORK ZONES	• 2	• 2	• 2
REBOUNDABLE DRUM			• 281	• 291	• 98

NOTES:

1. ALL TRAFFIC CONTROL DEVICES SHALL CONFORM TO THE MINNESOTA MANUAL ON UNIFORM TRAFFIC CONTROL DEVICES, INCLUDING THE FIELD MANUAL DATED JANUARY, 1998.
2. PAVEMENT MARKINGS IN ALL TAPER AREAS SHALL HAVE TEMPORARY RAISED PAVEMENT MARKERS AT 3m INTERVALS.
3. ALL TYPE III BARRICADES SHALL BE REFLECTORIZED ON BOTH SIDES, AND BARRICADE MARKINGS SHALL BE SLANTED IN ACCORDANCE WITH THE MINNESOTA MANUAL ON UNIFORM TRAFFIC CONTROL DEVICES.

NO	DATE	BY	CKD	APPR	REVISION

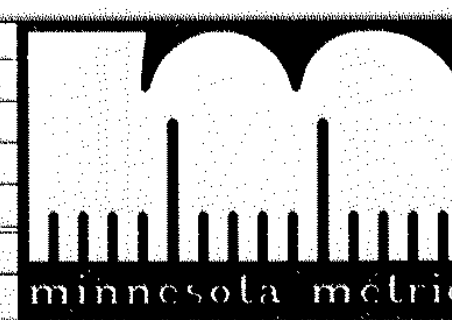

I HEREBY CERTIFY THAT THIS PLAN WAS PREPARED BY ME OR UNDER MY DIRECT SUPERVISION AND THAT I AM A DULY REGISTERED PROFESSIONAL ENGINEER UNDER THE LAWS OF THE STATE OF MINNESOTA.

DATE _____ REG. NO. _____

DRAWN BY _____ DATE _____
 DESIGN BY _____ DATE _____
 CHECKED BY _____ DATE _____

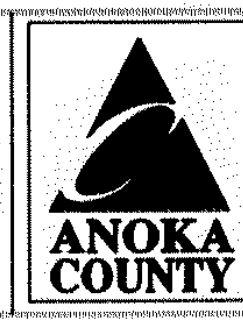

ANOKA COUNTY
HIGHWAY DEPT.

STATE PROJECT NO. 02-601-37
 STATE AID PROJECT NO. 127-020-20
 STATE AID PROJECT NO. 114-020-18
 COUNTY PROJECT NO. _____

STAGE QUANTITIES
EAST RIVER ROAD
C.S.A.H. 1
Sheet 93 of 93 Sheets