

ANOKA COUNTY HIGHWAY DEPARTMENT

CONSTRUCTION PLAN FOR GRADING, STORM SEWER, TRAIL AND BITUMINOUS PAVING COUNTY ROAD 116

FROM C.S.A.H. 83 (ARMSTRONG BLVD.) TO C.R. 56 (RAMSEY BLVD. N.W.)

GROSS LENGTH.....1712 METERS
BRIDGES-LENGTH.....0 METERS
EXCEPTIONS-LENGTH.....0 METERS
NET LENGTH.....1712 METERS



BEGIN 95-05-116
STA. 1+000

END 95-05-116
STA. 2+712

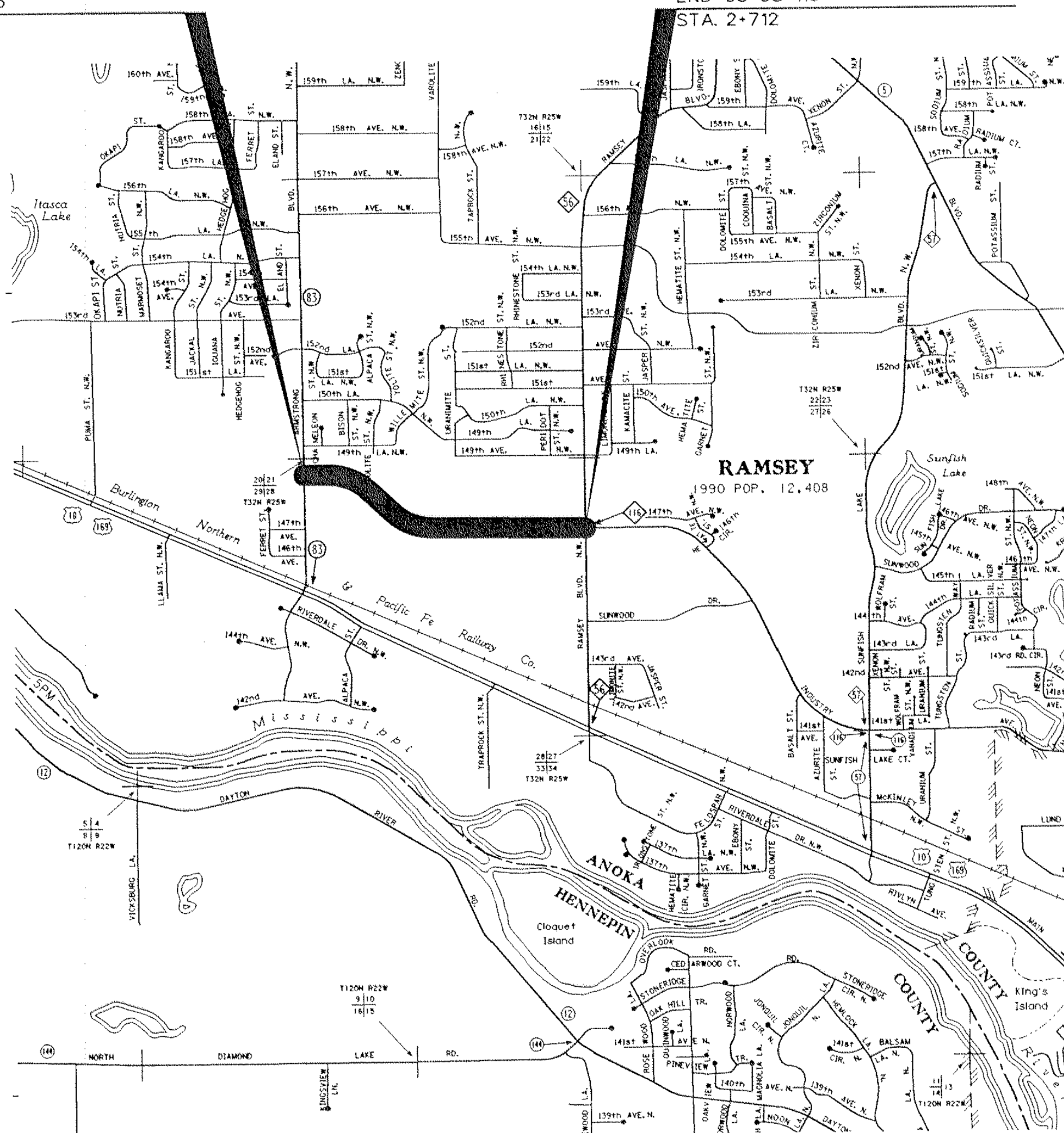

SCALES

PLAN	10	
PROFILE	10	1
	HORIZ.	VERT.
INDEX MAP	1000	
GENERAL LAYOUT	100	
X-SECTION	2	2
	HORIZ.	VERT.

ALL DIMENSIONS ARE IN METERS UNLESS NOTED OTHERWISE

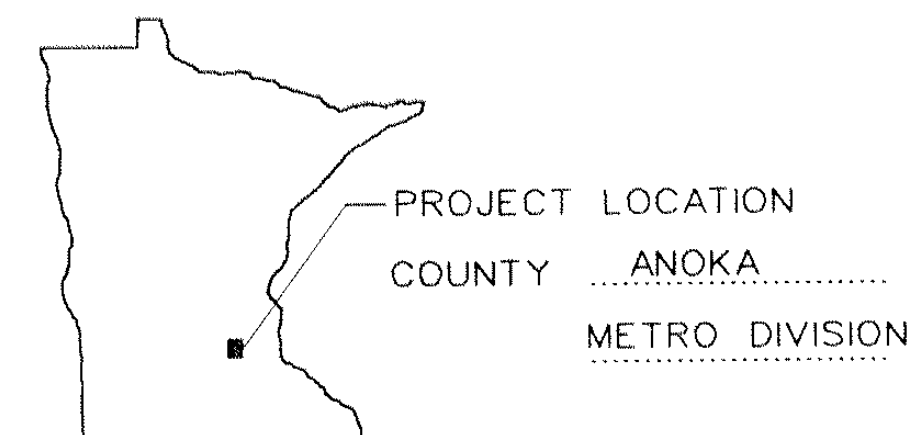

PLAN REVISIONS		
DATE	SHEET NO.	APPROVED BY

PLAN SYMBOLS

- STATE LINE.....
- COUNTY LINE.....
- TOWNSHIP OR RANGE LINE.....
- SECTION LINE.....
- QUARTER LINE.....
- SIXTEENTH LINE.....
- RIGHT-OF-WAY LINE.....
- PRESENT RIGHT-OF-WAY LINE.....
- CONTROL OF ACCESS LINE.....
- PROPERTY LINE (Except Land Lines).....
- VACATED PLATTED PROPERTY.....
- CORPORATE OR CITY LIMITS.....

- TRUNK HIGHWAY CENTER LINE.....
- RETAINING WALL.....
- RAILROAD.....
- RAILROAD RIGHT-OF-WAY LINE.....
- RIVER OR CREEK.....
- DRY RUN.....

- DRAINAGE DITCH.....
- DRAIN TILE.....
- CULVERT.....
- DROP INLET.....
- GUARD RAIL.....
- BARBED WIRE FENCE.....
- WOVEN WIRE FENCE.....
- CHAIN LINK FENCE.....
- RAILROAD SNOW FENCE.....
- STONE WALL OR FENCE.....
- HEDGE.....
- RAILROAD CROSSING SIGN.....
- RAILROAD CROSSING BELL.....
- ELECTRIC WARNING SIGN.....
- CROSSING GATE.....
- MEANDER CORNER.....

- SPRINGS.....
- MARSH.....
- TIMBER ORCHARD.....
- BRUSH.....
- NURSERY.....

- CATCH BASIN.....
- FIRE HYDRANT.....
- CATTLE GUARD.....
- OVERPASS (Highway Over).....
- UNDERPASS (Highway Under).....
- BRIDGE.....

- BUILDING (One Story Frame).....
- F-FRAME C-CONCRETE
- S-STONE T-TILE
- B-BRICK ST-STUCCO
- IRON PIPE OR ROD.....
- MONUMENT (STONE, CONCRETE, OR METAL).....
- WOODEN HUB.....
- GRAVEL PIT.....
- SAND PIT.....
- BORROW PIT.....
- ROCK QUARRY.....

UTILITY SYMBOLS

- POWER POLE LINE.....
- TELEPHONE OR TELEGRAPH POLE LINE.....
- JOINT TELEPHONE AND POWER ON POWER POLES ON TELEPHONE POLES.....

- ANCHOR.....
- STEEL TOWER.....
- STREET LIGHT.....
- PEDESTAL (TELEPHONE CABLE TERMINAL).....

- GAS MAIN.....
- WATER MAIN.....
- CONDUIT.....
- TELEPHONE CABLE IN CONDUIT.....
- ELECTRIC CABLE IN CONDUIT.....
- TELEPHONE MANHOLE.....
- ELECTRIC MANHOLE.....
- BURIED COMMUNICATION CABLE.....
- BURIED TELEPHONE CABLE.....
- BURIED ELECTRIC CABLE.....
- AERIAL TELEPHONE CABLE.....
- SEWER (SANITARY).....
- SEWER (STORM).....
- SEWER MANHOLE.....
- HANDHOLE.....
- CATCH BASIN.....

GOVERNING SPECIFICATIONS

THE 1995 EDITION OF THE MINNESOTA DEPARTMENT OF TRANSPORTATION "STANDARD SPECIFICATIONS FOR CONSTRUCTION" (METRIC) SHALL GOVERN.

ALL TRAFFIC CONTROL DEVICES SHALL CONFORM TO THE MINNESOTA MANUAL ON UNIFORM TRAFFIC CONTROL DEVICES, INCLUDING THE FIELD MANUAL FOR TEMPORARY TRAFFIC CONTROL ZONE LAYOUTS, DATED APRIL, 1995.

INDEX

SHEET NO.	SHEET DESCRIPTION
1	TITLE SHEET
2	GENERAL LAYOUT
3	STATEMENT OF ESTIMATED QUANTITIES
4	STD. PLATES AND SOILS/CONSTRUCTION NOTES
5-7	TABULATIONS
8-9	TYPICAL SECTIONS
10-12	STANDARD PLAN SHEETS
13	TRAFFIC CONTROL PLAN
14	ALIGNMENT PLAN & TABULATION
15-20	CONSTRUCTION PLAN & PROFILE
21	DRAINAGE PROFILES & TABULATION
22-25	EROSION CONTROL & TURF ESTABLISHMENT PLANS
26-29	SIGNING & STRIPING PLANS
30	WETLAND MITIGATION GRADING PLAN
31-59	CROSS SECTIONS

THIS PLAN CONTAINS 59 SHEETS.

C.R. 116	
DESIGN DESIGNATION	
FUNCTIONAL CLASSIFICATION	B MINOR ARTERIAL
NO. OF TRAFFIC LANES	2
NO. OF PARKING LANES	0
STRUCTURAL DESIGN	10 TON
R-VALUE	60
DESIGN SPEED	90 km/h
STOPPING SIGHT DISTANCE BASED ON:	
HEIGHT OF EYE	1070 mm
HEIGHT OF OBJECT	150 mm
ADT (CURRENT YEAR) (1998)	2800
ADT (FUTURE YEAR) (2018)	6000
Σ N18	740,000

I HEREBY CERTIFY THAT THIS PLAN WAS PREPARED BY ME OR UNDER MY DIRECT SUPERVISION AND THAT I AM A DULY REGISTERED PROFESSIONAL ENGINEER UNDER THE LAWS OF THE STATE OF MINNESOTA.

ENGR. *Michael D. Hansen*

Reg. No. 21364 Date 6-25-98



Approved: *[Signature]* DATE 7-1-98
CITY OF RAMSEY

Approved: *[Signature]* DATE 7/6/98
ANOKA COUNTY HIGHWAY ENGINEER

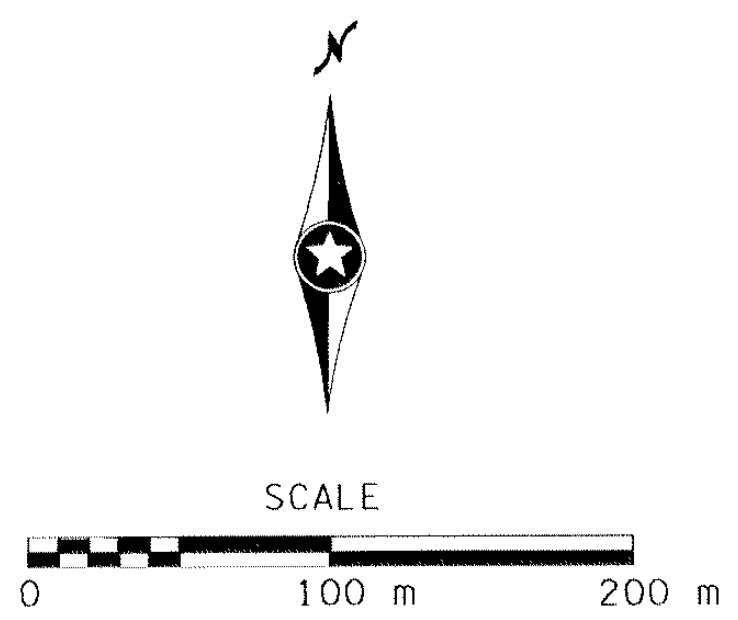
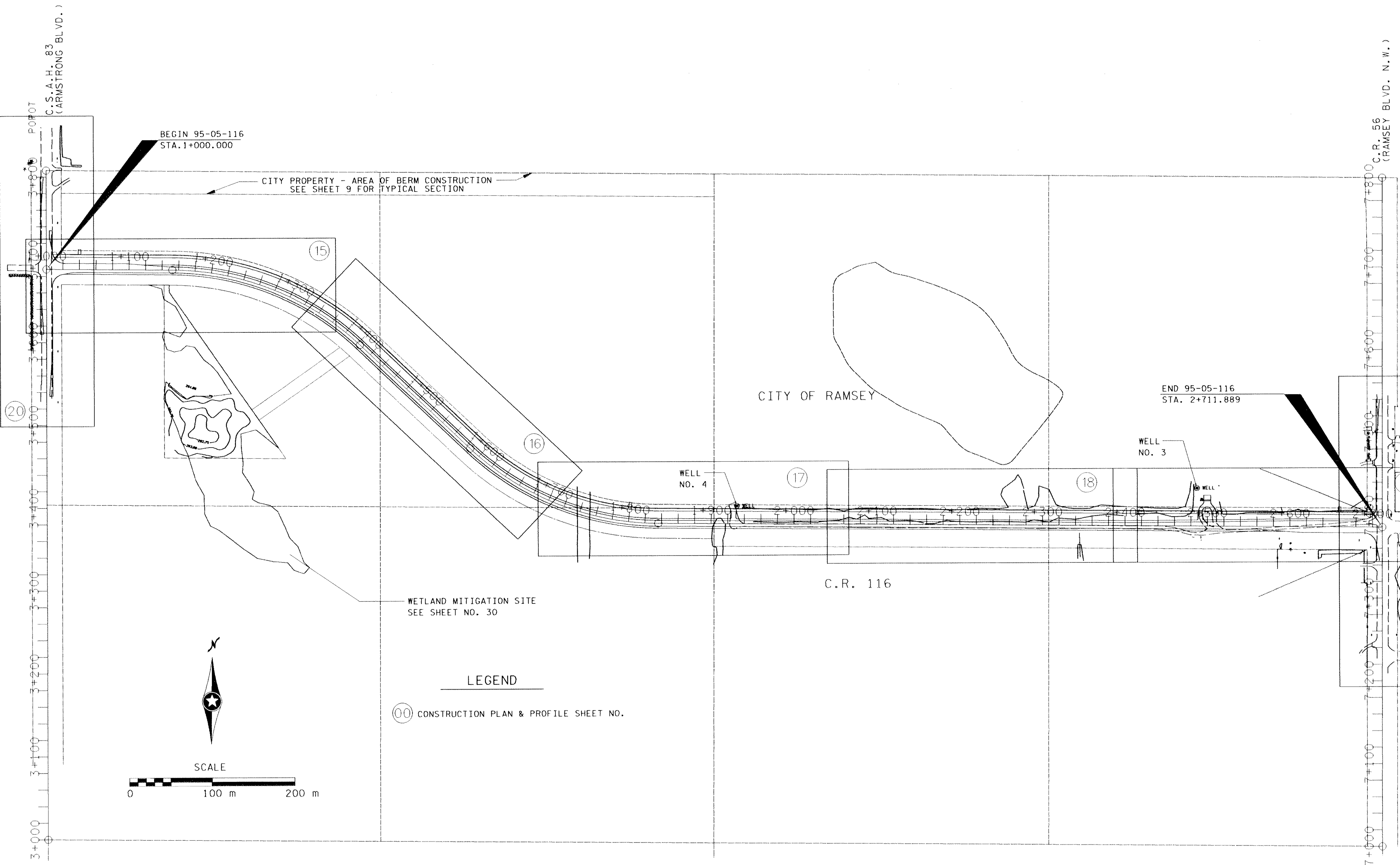

LEGEND
 (00) CONSTRUCTION PLAN & PROFILE SHEET NO.

DESIGN FILE: H:\CIVIL\047\2953\2953.dwg
 PRF FILE: H:\CIVIL\047\2953\2953.dpf
 PLOTTER: MS-DesignJet-Mono-PR-MD07
 PLOT SCALE: 1:1
 PLOT DATE/TIME: 06/23/98 13:09:20

NO	DATE	BY	CHKD	APPR	REVISION

NAME: 2953.GLA DATE: May. 20, 1998 TIME: 15:41:37

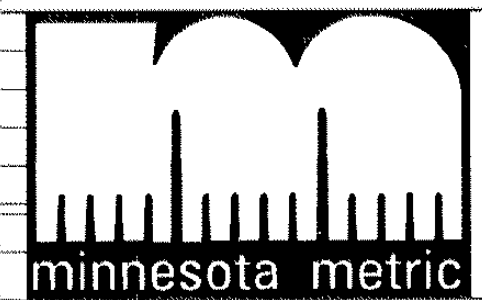

I hereby certify that this plan, specification or report was prepared by me or under my direct supervision and that I am a duly Registered Professional Engineer under the laws of the State of Minnesota.
Walter D. Hansen
 Date: 6-25-98 Reg. No. 21364

COUNTY PROJ. NO.
95-05-116
 CITY PROJECT NO.
97-25

DRAWN BY
W. ANDERSON
 DESIGNED BY
B. URBANEK
 CHECKED BY
M. HANSEN
 DATE
3-98
 COMM. NO.
0982953



ANOKA COUNTY
 GENERAL LAYOUT
 C.R. 116

SHEET
2
OF
59

STATEMENT OF ESTIMATED QUANTITIES

TAB	ITEM NO.	ITEM DESCRIPTION	UNIT	ANOKA COUNTY	CITY OF RAMSEY	TOTAL QUANTITY
				95-05-116	97-25	
	2013.601	CELLULAR MOBILE TELEPHONE	LS	1.0		1.0
	2015.601	COMPUTER EQUIPMENT	LS	1.0		1.0
	2021.501	MOBILIZATION	LS	1.0		1.0
	2031.501	FIELD OFFICE TYPE D	EA	1.0		1.0
A	2101.501	CLEARING	ha	1.03		1.03
A	2101.502	CLEARING	TREE	4.0		4.0
A	2101.506	GRUBBING	ha	1.03		1.03
A	2101.507	GRUBBING	TREE	4.0		4.0
J	2104.501	REMOVE WOVEN WIRE FENCE	m	19.0		19.0
B	2104.503	REMOVE BITUMINOUS PAVEMENT	m2	1567.0		1567.0
B	2104.513	SAWING BITUMINOUS PAVEMENT	m	591.0		591.0
J	2104.521	SALVAGE WOVEN WIRE FENCE	m	239.0		239.0
E	2104.523	SALVAGE 600 mm CONCRETE APRON	EA	1.0		1.0
G	2104.523	SALVAGE SIGN TYPE C	EA	6.0		6.0
C	2105.501	COMMON EXCAVATION (P)	m3	32155.0		32155.0
C	2105.501	COMMON EXCAVATION (SPECIAL) (1)	m3	8135.0		8135.0
C	2105.505	MUCK EXCAVATION	m3	2367.0		2367.0
C	2105.522	SELECT GRANULAR BORROW (LV) (6)	m3	3432.0		3432.0
C	2105.523	COMMON BORROW (LV)	m3	35769.0	11600.0	47369.0
	2130.501	WATER	m3	600.0	600.0	1200.0
D	2211.503	AGGREGATE BASE (CV) CLASS 5A (P)	m3	4625.0		4625.0
	2331.603	SAWED/SEALED JOINT	m	2250.0		2250.0
D	2350.609	TYPE LV 2 WEARING COURSE	t	2465.0		2465.0
D	2350.609	TYPE LV 2 NON-WEARING COURSE	t	3430.0		3430.0
D	2357.502	BITUMINOUS MATERIAL FOR TACK COAT	L	7220.0		7220.0
E	2501.511	375 mm CS PIPE CULVERT	m	20.4		20.4
E	2501.515	375 mm CS PIPE APRON	EA	4.0		4.0
E	2501.515	375 mm RC PIPE APRON	EA	2.0		2.0
E	2501.515	600 mm RC PIPE APRON	EA	2.0		2.0
E	2501.561	375 mm RC PIPE CULVERT DES 3006 CL III	m	3.9		3.9
E	2501.561	600 mm RC PIPE CULVERT DES 3006 CL III	m	107.0		107.0
E	2501.567	600 mm RC SAFETY APRON DES 3022	EA	6.0		6.0
E	2501.573	INSTALL 600 mm CONCRETE APRON	EA	1.0		1.0
E	2504.604	75mm POLYSTYRENE INSULATION (2)	m2	122.0		122.0
E	2506.501	CONST DRAIN STRUCTURE DESIGN F	m	1.7		1.7
E	2506.501	CONST DRAIN STRUCTURE DESIGN G	m	1.0		1.0
F	2506.516	CASTING ASSEMBLY	EA	2.0		2.0
	2521.511	50 mm BITUMINOUS WALK (3)	m2		5100.0	5100.0
E	2554.509	GUIDE POST, TYPE B	EA	15.0		15.0
J	2557.603	INSTALL WOVEN WIRE FENCE	m	239.0		239.0
G	2564.531	SIGN PANELS TYPE C (C.R.116)	m2	22.84		23.04
G	2564.531	SIGN PANELS TYPE C (C.R.83)	m2	3.31		3.31
G	2564.531	SIGN PANELS TYPE C (C.R.56)	m2	11.67		11.67
G	2564.536	INSTALL SIGN PANEL TYPE C	EA	6.0		6.0
	2564.552	TRAFFIC CONTROL (4)	LS	1.0		1.0
H	2564.603	100 mm SOLID LINE WHITE PAINT	m	4254.0		4254.0
H	2564.603	100 mm SOLID LINE YELLOW PAINT	m	589.0		589.0
H	2564.603	100 mm BROKEN LINE WHITE PAINT	m	45.0		45.0
H	2564.603	100 mm BROKEN LINE YELLOW PAINT	m	1215.0		1215.0
H	2564.603	100 mm DOUBLE SOLID LINE YELLOW PAINT	m	470.0		470.0
I	2573.501	BALE CHECK	EA	239.0		239.0
I	2573.502	SILT FENCE HEAVY DUTY	m	480.0		480.0
I	2575.501	SEEDING	ha	5.75	1.40	7.15
I	2575.502	SEED MIXTURE 70A	kg	258.0	70.0	328.0
I	2575.502	SEED MIXTURE 25A (5)	kg	30.0		30.0
I	2575.511	MULCH MATERIAL TYPE I	t	25.9	6.3	32.2
I	2575.519	DISC ANCHORING	ha	5.75	1.40	7.15
E,I	2575.523	EROSION CONTROL BLANKET STRAW TYPE 1S	m2	1484.0		1484.0
I	2575.532	COMMERCIAL FERT ANALYSIS 10-10-10	kg	3222.0	784.0	4006.0

NOTES:

- 1 EXCAVATION AT WETLAND MITIGATION SITE.
 - 2 FOR INSULATION OVER WATER MAIN AT STA. 1+940 AND 2+485.
 - 3 QUANTITY INCLUDES AGGREGATE BASE.
 - 4 SEE SHEET 13
 - 5 FOR WETLAND MITIGATION AREA. SEE SHEET 30.
 - 6 USED FOR MUCK EXCAVATION BACKFILL.
- (P) PLAN QUANTITY.

INDEX OF TABULATIONS

TAB.	TABULATION DESCRIPTION	SHEET NO.
A	CLEARING AND GRUBBING	5
B	MISCELLANEOUS REMOVAL AND SAWING	5
C	EARTHWORK TABULATION	5-6
D	AGGREGATE AND BITUMINOUS SUMMARY	5
E	DRAINAGE TABULATION	21
F	CASTING ASSEMBLIES SUMMARY	21
G	SIGN PANELS TYPE C	7
H	PAVEMENT MARKINGS	7
I	TURF ESTABLISHMENT / EROSION CONTROL	7
J	FENCE	7

DESIGN FILE: R:\CIVIL\047\2953\2953.dwg
 PLOTTER: HP-DesignJet-4600-PS-PT
 PLOT SCALE: 499.751000
 PLOT DATE/TIME: 06/29/98 12:05:58

1	6-29-98	MCI	JRD	REVISE ESTIMATED QUANTITIES
---	---------	-----	-----	-----------------------------

NO	DATE	BY	CHKD	APPR	REVISION

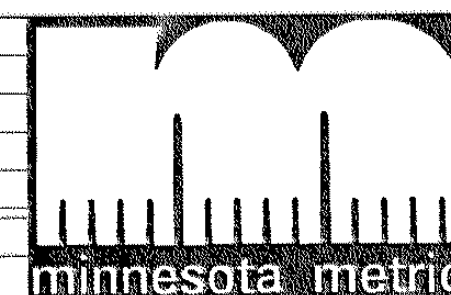

I hereby certify that this plan, specification or report was prepared by me or under my direct supervision and that I am a duly Registered Professional Engineer under the laws of the State of Minnesota.

Michael D. Hara
Date: 6-25-98 Reg. No. 21364

COUNTY PROJ. NO.
95-05-116

CITY PROJECT NO.
97-25

DRAWN BY: W. ANDERSON DATE: 3-98
 DESIGNED BY: B. URBANEK DATE: 3-98
 CHECKED BY: M. HANSEN DATE: 5-98
 COMM. NO. 0982953



ANOKA COUNTY
 STATEMENT OF ESTIMATED QUANTITIES
 C.R. 116

SHEET
 3
 OF
 59

THE FOLLOWING STANDARD PLATES APPROVED BY THE DEPARTMENT OF TRANSPORTATION FEDERAL HIGHWAY ADMINISTRATION SHALL APPLY ON THIS PROJECT.

STANDARD PLATES	
PLATE NO.	DESCRIPTION
M 3000 L	REINFORCED CONCRETE PIPE
M 3006 G	GASKET JOINT FOR R.C. PIPE
M 3007 B	SHEAR REINFORCEMENT FOR PRECAST DRAINAGE STRUCTURES
M 3022 B	PRECAST CONCRETE END SECTION
M 3100 G	CONCRETE APRON FOR REINFORCED CONCRETE PIPE
M 3133 C	RIPRAP AT RCP OUTLETS
M 3139 A	RIPRAP AT PRECAST CONCRETE END SECTIONS
M 3145 E	CONCRETE PIPE TIES
M 4005 L	MANHOLE OR CATCH BASIN
M 4006 L	MANHOLE OR CATCH BASIN
M 4007 C	PRECAST MECHANICAL JOINT SEWER MANHOLE
M 4010 H	CONC. SHORT CONE & ADJUSTING RING
M 4011 E	PRECAST CONCRETE BASE
M 4143 E	STOOL GRATE & CONCRETE FRAME
M 4180 J	MANHOLE OR CATCH BASIN STEP
M 8000 I	STANDARD BARRICADES
M 8150 E	INSTALLATION OF CULVERT MARKERS
M 9102 D	TURF ESTABLISHMENT AREAS (AT PIPE CULVERT ENDS)

CONSTRUCTION / SOILS NOTES

- SUITABLE GRADING MATERIAL ON THIS PROJECT SHALL CONSIST OF ALL SOILS ENCOUNTERED WITH THE EXCEPTION OF SLOPE DRESSING, DEBRIS, ORGANIC MATERIAL, MUCK AND OTHER UNSUITABLE MATERIAL.
- ITEMS REFERRED TO AS INCIDENTAL ON THIS PROJECT SHALL BE CONSIDERED INCIDENTAL WITH NO DIRECT COMPENSATION MADE THEREFORE.
- IN FILL AREAS THE SUBGRADE SHALL BE CONSTRUCTED WITH SELECT GRANULAR MATERIAL.
- SELECT GRANULAR MATERIAL IS DEFINED AS MATERIAL MEETING THE REQUIREMENTS OF 3149.2B2
- BITUMINOUS SURFACING REMOVED BY CONSTRUCTION SHALL BECOME THE PROPERTY OF THE CONTRACTOR AND SHALL EITHER BE RECYCLED OR DISPOSED OF OFF THE PROJECT, IN ACCORDANCE WITH THE PROVISIONS OF SPEC. 2104 AND 2105.
- UNSUITABLE MATERIALS INCLUDING EXCESS TOPSOIL SHALL BE PLACED ON CITY PROPERTY IDENTIFIED ON GENERAL LAYOUT SHEET. CONTRACTOR SHALL CREATE A 2 m HIGH BERM 2 m WIDE AT THE TOP WITH 1:3 SIDE SLOPES AS DIRECTED IN THE FIELD BY THE ENGINEER.
- COMPACTION OF THE GRADING ITEMS OF THIS PROJECT SHALL BE BY THE "SPECIFIED DENSITY METHOD", EXCEPT WHEN WITHIN 1 m OF THE WATER TABLE, THEN BY THE "QUALITY COMPACTION METHOD".
- COMPACTION OF THE AGGREGATE BASE ITEMS OF THIS PROJECT SHALL BE BY THE "SPECIFIED DENSITY METHOD" EXCEPT WHEN THE CONTRACTOR ELECTS TO USE RECYCLED MATERIALS FOR THE AGGREGATE BASE ITEMS, THEN THE "QUALITY COMPACTION METHOD" SHALL BE UTILIZED.
- GRADING GRADE ON THIS PROJECT SHALL BE DEFINED AS THE BOTTOM OF THE AGGREGATE BASE AS SHOWN ON THE TYPICAL SECTIONS.
- STABILIZING AGGREGATE SHALL BE INCORPORATED INTO THE SUBGRADE TO ACHIEVE SATISFACTORY SURFACE STABILITY AT LOCATIONS DEEMED NECESSARY BY THE ENGINEER, IN ACCORDANCE WITH THE PROVISIONS OF SPEC. 2105.3G. GRANULAR MATERIAL WHICH IS FURNISHED BY THE CONTRACTOR SHALL BE STABILIZED, IF NECESSARY, AT THE CONTRACTOR'S EXPENSE. WHERE STABILIZING AGGREGATE IS DEEMED NECESSARY, IT SHALL BE APPLIED AT A RATE OF APPROXIMATELY 110 KILOGRAMS PER SQUARE METER.
- WHERE WIDENING ADJACENT TO EXISTING PAVEMENT, CUT VERTICALLY TO THE BOTTOM OF THE AGGREGATE BASE AND THEN AT A 1V:1/2H SLOPE TO THE BOTTOM OF THE RECOMMENDED SUBGRADE EXCAVATION (AS SHOWN ON THE TYPICAL SECTIONS AND THE CROSS SECTIONS). BACKFILL PROMPTLY TO AVOID UNDERMINING THE EXISTING PAVEMENT.
- PROVIDE 1V:20H LONGITUDINAL TAPERS BETWEEN CHANGES IN SUBGRADE AND SUBCUT DEPTHS.
- USE TACK COAT BETWEEN ALL BITUMINOUS MIXTURES.
- STRIP AND REUSE AS SLOPE DRESSING ALL EXISTING TOPSOIL, WHERE PRESENT, IN AREAS TO BE DISTURBED BY CONSTRUCTION. TOPSOIL STRIPING IS CONSIDERED TO BE COMMON EXCAVATION. ALL TOPSOIL SHALL BE UTILIZED ON THE PROJECT.
- PLACE A MINIMUM OF 150 MILLIMETERS OF SLOPE DRESSING ON ALL AREAS SCHEDULED FOR PERMANENT TURF ESTABLISHMENT.
- SEEDING REQUIREMENTS ON THIS PROJECT SHALL BE AS FOLLOWS:
 - SEED MIXTURE 70A SHALL BE APPLIED AT A RATE OF 50 KILOGRAMS PER HECTARE.
 - MULCH MATERIAL TYPE I SHALL BE APPLIED AT A RATE OF 4.5 METRIC TONS PER HECTARE.
 - COMMERCIAL FERTILIZER ANALYSIS 10-10-10 (OR EQUIVALENT) SHALL BE APPLIED AT A RATE OF 560 KILOGRAMS PER HECTARE.
- DITCH BOTTOMS, TOE OF FILL, CUT RUNOUTS AND THE TOP EDGE OF THE BACKSLOPES SHALL BE ROUNDED REGARDLESS OF THE SECTION USED ON THE CROSS SECTION SHEETS.
- ALL TRAFFIC CONTROL DEVICES SHALL CONFORM TO THE MINNESOTA MANUAL ON UNIFORM TRAFFIC CONTROL DEVICES, INCLUDING THE FIELD MANUAL FOR TEMPORARY TRAFFIC CONTROL ZONE LAYOUTS, DATED JAN. 1998.
- COMMON BORROW MATERIAL SHALL HAVE A MINIMUM R-VALUE OF 60. BORROW MATERIAL PLACED WITHIN THE UPPER 1.2 m OF THE EMBANKMENT BELOW THE GRADING GRADE SHALL BE SELECT GRANULAR MATERIAL.

DESIGN FILE: H:\CIVIL\1047\2953\2953.dgn
 PRF FILE: H:\CIVIL\1047\2953\2953.drf
 PLOTTER: MS-DOS/PlotJet-Mono-FR-MRDOT
 PLOT SCALE: 499.751000
 PLOT DATE/TIME: 06/29/98 12:01:48

1	6-29-98	MCI	JRD	REVISE NOTE 16 AND 18
---	---------	-----	-----	-----------------------

NO	DATE	BY	CKD	APPR	REVISION



I hereby certify that this plan, specification or report was prepared by me or under my direct supervision and that I am a duly Registered Professional Engineer under the laws of the State of Minnesota.

Michael D. Hansen
 Date: 6-25-98 Reg. No. 21364

COUNTY PROJ. NO.
95-05-116

CITY PROJECT NO.
97-25

DRAWN BY
W. ANDERSON 3-98

DESIGNED BY
B. URBANEK 3-98

CHECKED BY
M. HANSEN 5-98

COMM. NO.
0982953



ANOKA COUNTY
STANDARD PLATES AND SOILS/CONSTRUCTION NOTES
C.R. 116

SHEET
4
OF
59

(A) CLEARING AND GRUBBING TABULATION								
ALIGNMENT	STATION TO STATION		OFFSET		CLEARING		GRUBBING	
			LEFT	RIGHT	(tree)	(ha)	(tree)	(ha)
C.R. 116	1+735	1+752	19.0	17.0		0.06		0.06
C.R. 116	1+903	1+913	11.0	18.0		0.03		0.03
C.R. 116	1+940	2+066	19.0			0.17		0.17
C.R. 116	2+066	2+400	19.0			0.67		0.67
C.R. 116	2+400	2+482	19.0			0.06		0.06
C.R. 116	2+501		17.0		1		1	
C.R. 116	2+512		17.0		1		1	
C.R. 116	2+518	2+600	18.0			0.03		0.03
C.R. 116	2+590			15.0	1		1	
C.R. 116	2+600			15.0	1		1	
C.R. 116	2+676	2+695	19.0			0.01		0.01
TOTAL					4	1.03	4	1.03

NOTES: TREES WITHIN THE CONSTRUCTION LIMITS WILL BE DESIGNATED FOR REMOVAL BY THE ENGINEER. ALL TREES TO BE TRANSPLANTED WILL BE TRANSPLANTED BY OTHERS. REMOVAL OF MISCELLANEOUS SHRUBS AND LANDSCAPING SHALL BE CONSIDERED INCIDENTAL.

(B) MISC. REMOVAL AND SAWING TABULATION					
ALIGNMENT	STATION TO	STATION	LOCATION	REMOVE BITUMINOUS PAVEMENT (m ²)	SAWING BITUMINOUS PAVEMENT (m)
C.S.A.H. 83	3+605	3+800	LT	479	195
C.S.A.H. 83	3+535	3+725	RT	505	190
C.S.A.H. 83	3+685	3+696	LT	583	11
C.R. 56	7+345	7+540	LT		195
PROJECT TOTALS:				1567	591

NOTES:

(D) AGGREGATE AND BITUMINOUS SUMMARY TABULATION						
ALIGNMENT	STATION TO STATION		AGGREGATE BASE CLASS 5A (m ³)	2350	2350	TACK (l)
				TYPE LV 2 WEAR (LVWE35030B) (t)	TYPE LV 2 NON WEAR (LVNW35030B) (t)	
C.S.A.H. 83	3+535	3+725	120	50	150	250
C.S.A.H. 83	3+605	3+800	110	45	130	220
C.R. 56	7+345	7+540	95	50	100	250
C.R. 116	1+006	2+706	4300	2320	3050	6500
PROJECT TOTALS:			4625	2465	3430	7220

(C) EARTHWORK SUMMARY					
ALIGNMENT	EXCAVATION TOTALS (EV)		EMBANKMENT TOTALS (CV)		
	COMMON (m ³)	MUCK (m ³)	SUITABLE GRADING (m ³)	SLOPE DRESSING (m ³)	SELECT GRANULAR (m ³)
C.R. 116	31101	2135	39260	5581	2135
C.S.A.H. 83	640	232	628	144	232
C.R. 56	414	0	161	72	0
MITIGATION SITE	8135	0	0	1892	0
TOTALS:	40290	2367	40049	7689	2367

NOTES:

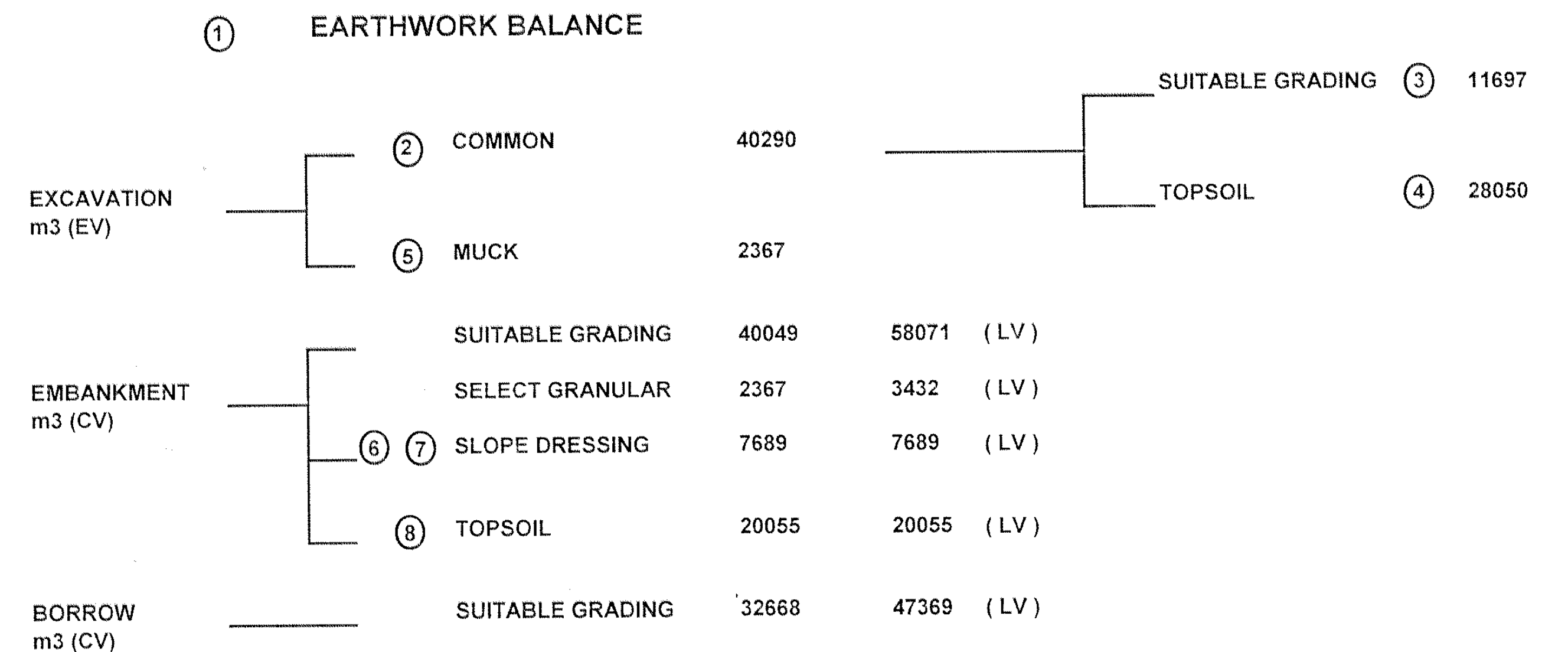

NOTES:

- SEE CONSTRUCTION/SOIL NOTES FOR MATERIAL DEFINITIONS AND ADDITIONAL INFORMATION.
- 120% SHRINKAGE FACTOR USED FROM EXCAVATED VOLUME (EV) TO COMPACTED VOLUME (CV), EXCEPT FOR TOPSOIL. 145% SHRINKAGE FACTOR USED FROM LOOSE VOLUME (LV) TO COMPACTED VOLUME (CV), EXCEPT FOR TOPSOIL. SHRINKAGE FACTORS ARE ASSUMED VALUES, USED ONLY FOR THE PURPOSE OF ESTIMATED QUANTITIES. IT SHALL BE UNDERSTOOD THAT NO WARRANTY IS MADE OR IMPLIED AS TO THE ACCURACY, SUFFICIENCY, OR RELIABILITY OF THE SHRINKAGE FACTOR.
 - INCLUDES TOPSOIL STRIPPING (ASSUMED TO BE 400 mm THICK).
 - INCLUDES 5613 m³ (EV) SUITABLE GRADING FROM MITIGATION SITE. DEPENDING ON QUALITY OF GRADING MATERIAL, CONTRACTOR SHALL OVEREXCAVATE MITIGATION SITE AT THE DIRECTION OF THE ENGINEER TO GENERATE ADDITIONAL EMBANKMENT MATERIAL.
 - INCLUDES 2522 m³ (EV) TOPSOIL STRIPPING FROM MITIGATION SITE.
 - MUCK EXCAVATION TO BE USED AS POND LINING IN THE MITIGATION SITE. BACKFILL MUCK EXCAVATION WITH SELECT GRANULAR.
 - INCLUDES 1892 m³ (CV) OF SLOPE DRESSING FOR MITIGATION SITE.
 - SLOPE DRESSING TO BE PLACED AT A UNIFORM THICKNESS OF 300 mm IN THE MITIGATION SITE.
 - 20055 m³ (CV) OF TOPSOIL TO BE USED FOR CONSTRUCTION OF A BERM AS DIRECTED BY THE ENGINEER. SEE SHEET 2 FOR BERM LOCATION AND SHEET 9 FOR BERM TYPICAL SECTION.

DESIGN FILE: H:\G1\11\047\2953\2953.dwg
 PRF FILE: H:\G1\11\047\2953\2953.dwg
 PLOTTER: MS-Desi\gplot-Mono-FR-WH00T
 PLOT SCALE: 1/32" = 1'-0"
 PLOT DATE/TIME: 06/29/98 12:38:04

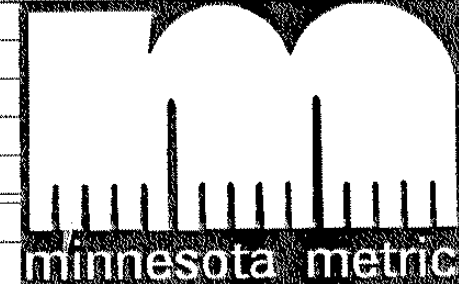
				I hereby certify that this plan, specification or report was prepared by me or under my direct supervision and that I am a duly Registered Professional Engineer under the laws of the State of Minnesota. <i>M. Hansen</i> Date <u>6-25-98</u> Reg. No. <u>21364</u>		COUNTY PROJ. NO. <u>95-05-116</u> CITY PROJECT NO. <u>97-25</u>		DRAWN BY <u>W. ANDERSON</u> DATE <u>3-98</u> DESIGNED BY <u>B. URBANEK</u> 3-98 CHECKED BY <u>M. HANSEN</u> 5-98 COMM. NO. <u>0982953</u>		ANOKA COUNTY EARTHWORK SUMMARY AND TABULATIONS A, B, C, D C.R. 116		SHEET 5 OF 59
NO	DATE	BY	CKD	APPR	REVISION							
NAME: 2953.ETA DATE: May. 19, 1998 TIME: 10:19:18												



DESIGN FILE: H:\G11\11047\2953\2953.eb
 PRF FILE: H:\G11\11047\2953\2953.prf
 PLOT SCALE: 1"=40'
 PLOT DATE/TIME: 06/29/98 12:38:36

(C) EARTHWORK TABULATION - C.R. 116					
STATION	EXCAVATION TOTALS (EV)		EMBANKMENT TOTALS (CV)		
	COMMON	MUCK	SUITABLE GRADING	SLOPE DRESSING	SELECT GRANULAR
	m3	m3	m3	m3	m3
1+000.000					
1+020.000	0	243	810	48	243
1+040.000	0	482	812	49	482
1+060.000	0	477	776	54	477
1+080.000	1	478	750	58	478
1+100.000	107	347	744	61	347
1+120.000	273	108	709	63	108
1+140.000	341	0	639	64	0
1+160.000	375	0	542	65	0
1+180.000	413	0	511	66	0
1+200.000	405	0	529	65	0
1+220.000	394	0	524	64	0
1+240.000	393	0	517	63	0
1+260.000	381	0	529	62	0
1+280.000	361	0	540	62	0
1+300.000	353	0	521	61	0
1+320.000	354	0	513	62	0
1+340.000	351	0	528	64	0
1+360.000	352	0	536	65	0
1+380.000	355	0	508	66	0
1+400.000	354	0	403	65	0
1+420.000	335	0	309	62	0
1+440.000	322	0	293	61	0
1+460.000	316	0	316	61	0
1+480.000	289	0	343	59	0
1+500.000	274	0	348	57	0
1+519.999	271	0	369	56	0
1+540.000	257	0	432	51	0
1+559.999	260	0	519	52	0
1+580.000	271	0	587	57	0
1+600.000	280	0	591	60	0
1+620.000	296	0	511	64	0
1+640.000	309	0	381	65	0
1+660.000	321	0	308	65	0
1+680.000	323	0	267	63	0
1+700.000	329	0	236	63	0
1+720.000	323	0	277	63	0
1+740.000	341	0	268	63	0
1+760.000	338	0	336	64	0
1+780.000	299	0	500	64	0
1+800.000	303	0	599	67	0
1+820.000	309	0	742	70	0
1+840.000	302	0	882	68	0
1+860.000	296	0	848	66	0
1+880.000	302	0	646	67	0
1+900.000	337	0	384	67	0
1+920.000	416	0	201	69	0
1+940.000	473	0	169	73	0
1+960.000	464	0	242	76	0
1+980.000	432	0	380	78	0
2+000.000	396	0	511	78	0
2+020.000	363	0	587	76	0
2+040.000	333	0	607	72	0
2+060.000	312	0	616	68	0
2+080.000	305	0	592	67	0
2+100.000	303	0	491	66	0
2+120.000	297	0	358	62	0
2+140.000	288	0	231	55	0
2+160.000	319	0	142	51	0
2+180.000	337	0	114	52	0
2+200.000	337	0	120	52	0
2+220.000	326	0	150	51	0
2+240.000	287	0	227	51	0
2+260.000	277	0	398	56	0
2+280.000	281	0	468	59	0
2+300.000	281	0	426	59	0
2+320.000	302	0	498	68	0
2+340.000	297	0	526	66	0
2+360.000	277	0	511	55	0
2+380.000	319	0	467	61	0
2+400.000	473	0	303	73	0
2+420.000	647	0	169	80	0
2+440.000	599	0	160	79	0
2+460.000	544	0	154	76	0
2+480.000	587	0	151	79	0
2+500.000	632	0	242	86	0
2+520.000	658	0	322	87	0
2+540.000	695	0	242	86	0
2+560.000	820	0	127	88	0
2+580.000	872	0	112	87	0
2+600.000	769	0	180	83	0
2+620.000	638	0	307	78	0
2+640.000	553	0	557	78	0
2+660.000	430	0	1085	76	0
2+680.000	356	0	1489	74	0
2+700.000	325	0	1059	52	0
2+711.889	171	0	336	16	0
TOTAL:	31101	2135	39260	5581	2135

(C) EARTHWORK TABULATION - C.S.A.H. 83					
STATION	EXCAVATION TOTALS (EV)		EMBANKMENT TOTALS (CV)		
	COMMON	MUCK	SUITABLE GRADING	SLOPE DRESSING	SELECT GRANULAR
	m3	m3	m3	m3	m3
3+536.300					
3+560.000	16	0	7	1	0
3+580.000	46	0	27	7	0
3+600.000	69	0	47	12	0
3+620.000	78	0	58	13	0
3+640.000	95	0	66	15	0
3+660.000	114	0	77	17	0
3+680.000	97	0	69	15	0
3+700.000	68	0	48	10	0
3+720.000	57	43	52	12	43
3+740.000	49	85	71	15	85
3+760.000	51	73	68	16	73
3+780.000	37	31	33	10	31
3+796.900	10	0	5	1	0
TOTAL:	640	232	628	144	232

(C) EARTHWORK TABULATION - C.R. 56					
STATION	EXCAVATION TOTALS (EV)		EMBANKMENT TOTALS (CV)		
	COMMON	MUCK	SUITABLE GRADING	SLOPE DRESSING	SELECT GRANULAR
	m3	m3	m3	m3	m3
7+400.000					
7+420.000	49	0	16	10	0
7+440.000	114	0	31	22	0
7+460.000	105	0	30	19	0
7+480.000	68	0	35	11	0
7+500.000	45	0	30	6	0
7+520.000	25	0	15	3	0
7+536.900	8	0	4	1	0
TOTAL:	414	0	161	72	0

NO	DATE	BY	CHK	APPR	REVISION



I hereby certify that this plan, specification or report was prepared by me or under my direct supervision and that I am a duly Registered Professional Engineer under the laws of the State of Minnesota.
W. Anderson
 Date: 6-25-98 Reg. No. 21364

COUNTY PROJ. NO. 95-05-116
 CITY PROJECT NO. 97-25

DRAWN BY W. ANDERSON DATE 3-98
 DESIGNED BY B. URBANEK DATE 3-98
 CHECKED BY M. HANSEN DATE 5-98
 COMM. NO. 0982953



ANOKA COUNTY
 EARTHWORK TABULATION C
 C.R. 116

SHEET 6 OF 59

(G) SIGN PANELS TYPE C TABULATION											
FURNISH & INSTALL					SALVAGE	INSTALL	CODE NO.	PANEL LEGEND	QUANTITY (EACH)	QUANTITY (EACH)	
QUANTITY (EACH)	SIZE (IN)	AREA (SQ FT)	TOTAL AREA (SQ FT)	TOTAL AREA (m2)	QUANTITY (EACH)	QUANTITY (EACH)					
4	48 X 48	16.00	64.00	5.95			R1 - 1	STOP			
6	36 X 36	9.00	54.00	5.02			R1 - 1	STOP			
8	18 X 6	0.75	6.00	0.56			R1 - 4	ALLWAY			
1	24 X 30	5.00	5.00	0.46			R2 - 1	SPEED LIMIT			
3	30 X 30	6.25	18.75	1.74			R3 - X1	RIGHT TURN LANE			
2	30 X 30	6.25	12.50	1.16			W1 - 2L	LEFT CURVE			
2	30 X 30	6.25	12.50	1.16			W1 - 2R	RIGHT CURVE			
1	48 X 24	8.00	8.00	0.74			W1 - 7	LARGE ARROWS			
5	36 X 36	9.00	45.00	4.18			W3 - 1a	STOP AHEAD (WORD MESSAGE)			
5	48 X 48	16.00	80.00	7.43			W3 - 1a	STOP AHEAD (WORD MESSAGE)			
2	36 X 48	6.00	12.00	1.11			W14 - 3	NO PASSING ZONE			
2	24 X 12	2.00	4.00	0.37			M3 - 1	NORTH			
2	21 X 15	2.19	4.38	0.41			M2 - 1	JCT			
	24 X 12	2.00	0.00	0.00	1	1	M4 - 6	END			
	21 X 15	2.19	0.00	0.00	2	2	M6 - 1	ARROW			
3	24 X 12	2.00	6.00	0.56			M3 - 2	EAST			
2	24 X 12	2.00	4.00	0.37			M3 - 3	SOUTH			
6	24 X 24	4.00	24.00	2.23	3	3	M1 - 6	COUNTY ROUTE MARKER (CR 116)			
4	24 X 24	4.00	16.00	1.49			M1 - 6	COUNTY ROUTE MARKER (CR 83)			
5	24 X 24	4.00	20.00	1.86			M1 - 6	COUNTY ROUTE MARKER (CR 56)			
5	21 X 15	2.19	10.94	1.02			M6 - 4	ARROW			
PROJECT TOTAL:				37.82	6	6					

NOTES:
SEE STANDARD SIGNS MANUAL FOR PUNCHING CODE AND DETAILED DRAWINGS OF TYPE "C" SIGN PANELS.

(H) PAVEMENT MARKINGS TABULATION								
ALIGNMENT	STATION TO STATION	LOCATION	SOLID LINE		BROKEN LINE		DOUBLE SOLID LINE	
			100 mm WHITE (m)	100 mm YELLOW (m)	100 mm WHITE (m)	100 mm YELLOW (m)	100 mm YELLOW (m)	
C.R. 116	1+015	2+700	LT	1685				
C.R. 116	1+015	2+700	RT	1685				
C.R. 116	1+015	1+100	LT	85				
C.R. 116	2+614	2+700	RT	86				
C.S.A.H. 83	3+615	3+797	LT	182				
C.S.A.H. 83	3+595	3+670	RT	75				
C.S.A.H. 83	3+535	3+722	RT	187				
C.R. 56	7+404	7+479	LT	75				
C.R. 56	7+340	7+534	LT	194				
C.R. 116	1+015	1+155	CL					140
C.R. 116	1+480	1+670	CL					190
C.R. 116	2+560	2+700	CL					140
C.R. 116	1+155	1+480	CL				325	
C.R. 116	1+670	2+560	CL				890	
C.R. 116	1+788	1+982	CL		194			
C.R. 116	2+165	2+560	CL		395			
C.S.A.H. 83	3+683	3+728	LT			45		
PROJECT TOTALS:				4254	589	45	1215	470

(I) TURF ESTABLISHMENT / EROSION CONTROL TABULATION												
ALIGNMENT	STATION TO STATION	LOCATION	SEEDING (ha)	SEED MIXTURE		MULCH MATERIAL TYPE (t)	BALE DITCH SEDIMENT CHECK (EACH)	SILT FENCE HEAVY DUTY (m)	DISK ANCHOR (ha)	EROSION CONTROL BLANKETS STRAW 1S (m2)	COMMERCIAL FERTILIZER 10-10-10 (kg)	REMARKS
				25A MIX (kg)	70A MIX (kg)							
C.R. 116		LT					105					CHECK
C.R. 116		LT					12					APRON
C.R. 116		RT					98					CHECK
C.R. 116		RT					21					APRON
C.S.A.H. 83		LT					3					APRON
C.S.A.H. 83	3+695	3+795	LT					100				
C.S.A.H. 83	3+710	3+745	RT					39				
C.S.A.H. 83	3+586	3+672	RT					86				
C.R. 116	1+022	1+102	LT					80				
C.R. 116	1+020	1+155	RT					135				
C.R. 116	1+833	1+873	RT					40				
C.R. 116	1+095	1+460	RT						657			
C.R. 116	1+528	1+894	LT						659			
C.R. 116		LT	2.00		100	9.0			2.00		1120	
C.R. 116		RT	2.45		123	11.0			2.45		1372	
C.S.A.H. 83		LT	0.20		10	0.9			0.20		114	
C.S.A.H. 83		RT	0.30		15	1.4			0.30		168	
C.R. 56		LT	0.20		10	0.9			0.20		112	
C.R. 116	1+200	RT	0.60	30		2.7			0.60		336	MITIGATION AREA
BERM			1.40		70	6.3			1.40		784	
PROJECT TOTALS:			7.15	30	328	32.2	239	480	7.15	1316	4006	

NOTE:
QUANTITIES ARE BASED ON SEEDING THE ENTIRE RIGHT-OF-WAY AND THE FOLLOWING RATES:
SEED MIXTURE 70A 50 kg/ha
SEED MIXTURE 25A 50 kg/ha
MULCH TYPE 4.5 t/ha
COMM. FERT. 560 kg/ha

(J) FENCE TABULATION					
ALIGNMENT	STATION TO STATION	LOCATION	WOVEN WIRE		
			REMOVE (m)	SALVAGE (m)	INSTALL (m)
C.R. 116	2+345	RT	19		
C.R. 116	2+414	2+485	LT	71	71
C.R. 116	2+526	2+694	LT	168	168
PROJECT TOTALS:			19	239	239

DESIGN FILE: H:\CIVIL\11047\2953\2953.etc
 PLOT FILE: H:\CIVIL\11047\2953\2953.drf
 PLOTTER: MS-DesignJet-Mono-FR-MN001
 PLOT SCALE: 499, 751000
 PLOT DATE/TIME: 06/29/98 12:39:14

NO	DATE	BY	CHKD	APPR	REVISION
1	6-29-98	MCI	MDH		REV. TAB G

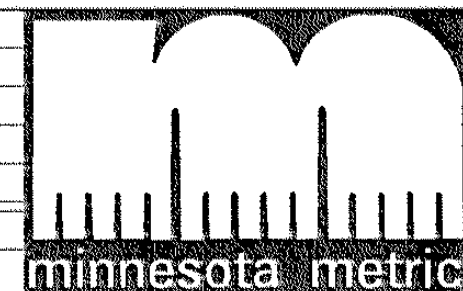

I hereby certify that this plan, specification or report was prepared by me or under my direct supervision and that I am a duly Registered Professional Engineer under the laws of the State of Minnesota.
[Signature]
 Date: 6-25-98 Reg. No. 21364

COUNTY PROJ. NO.
95-05-116
CITY PROJECT NO.
97-25

DRAWN BY DATE
J. HAMRE 6-98
DESIGNED BY
S. LILLEHAUG 6-98
CHECKED BY
M. HANSEN 5-98
COMM. NO.
0982953



ANOKA COUNTY
TABULATIONS G, H, I, J
C.R. 116

SHEET
7
OF
59

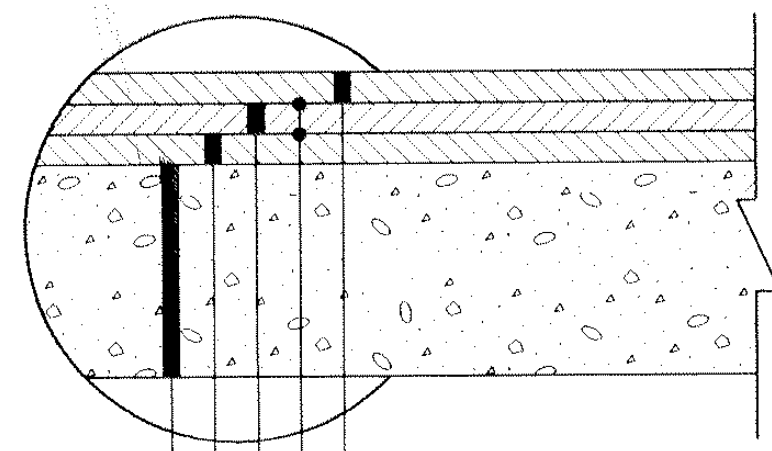

DETAIL D

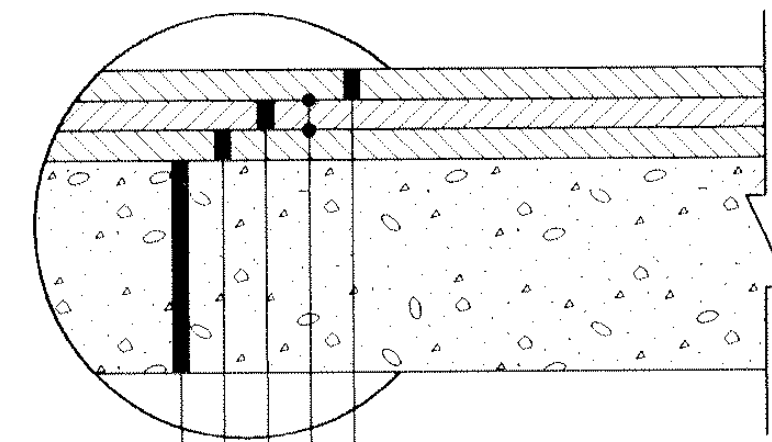

DETAIL E

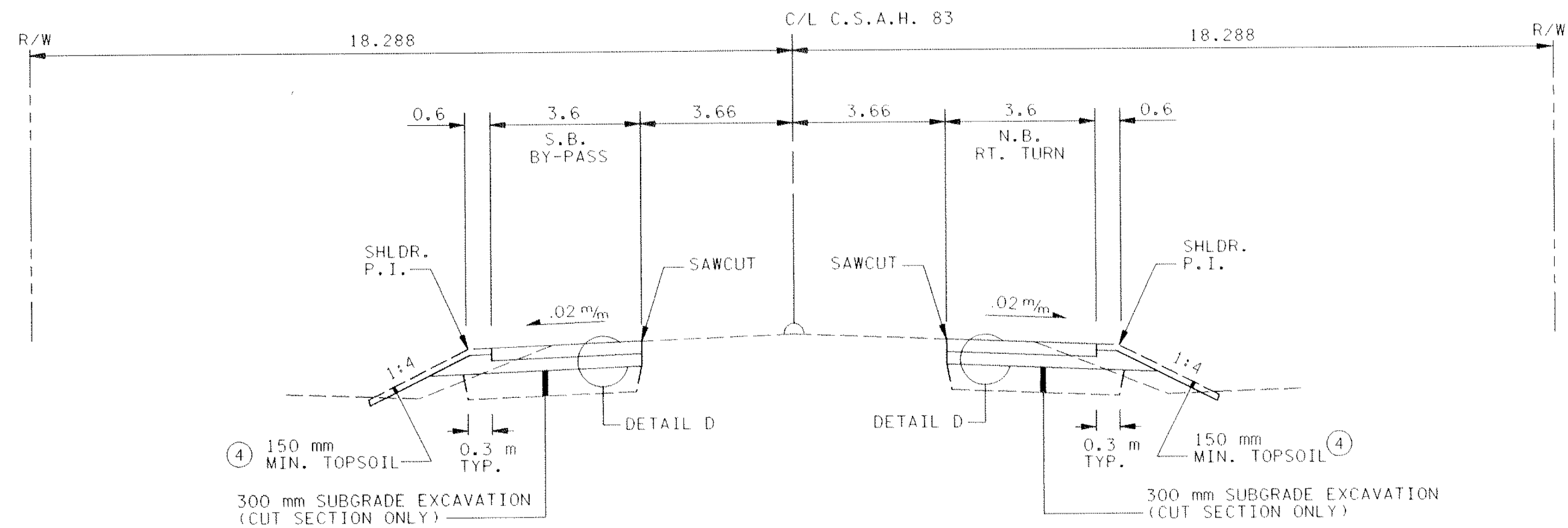

C.S.A.H. 83
TYPICAL SECTION

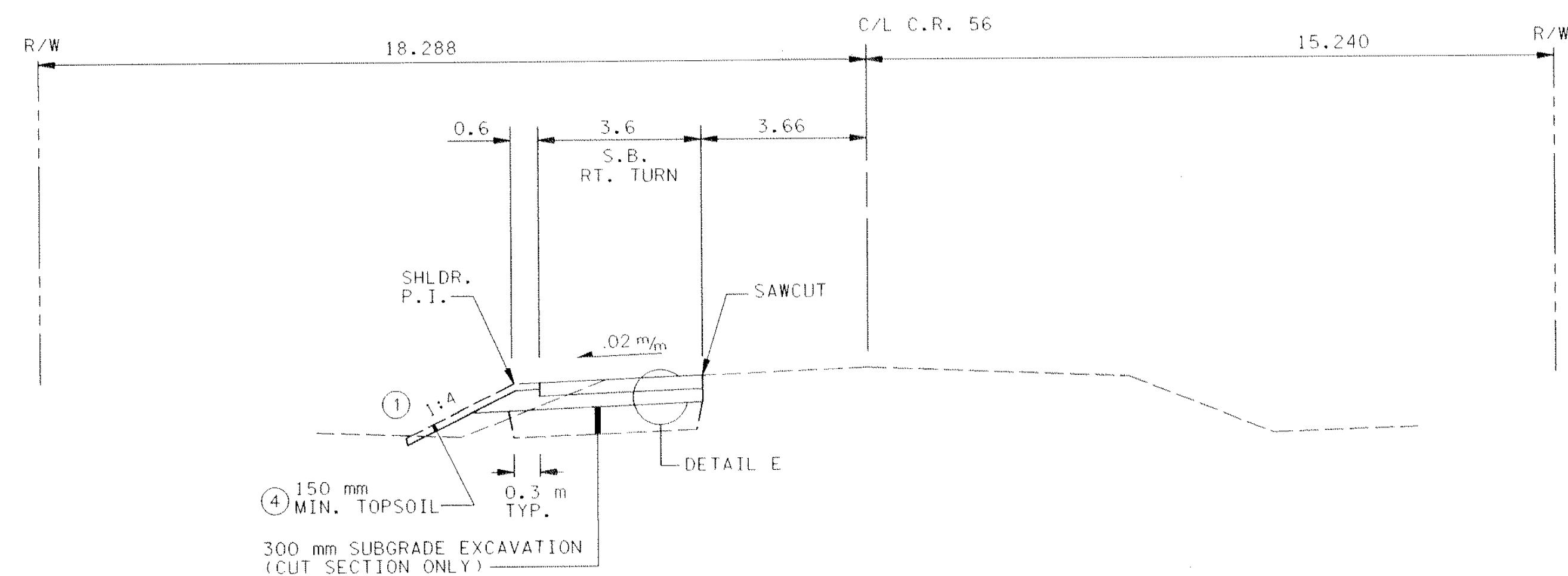

C.R. 56
TYPICAL SECTION

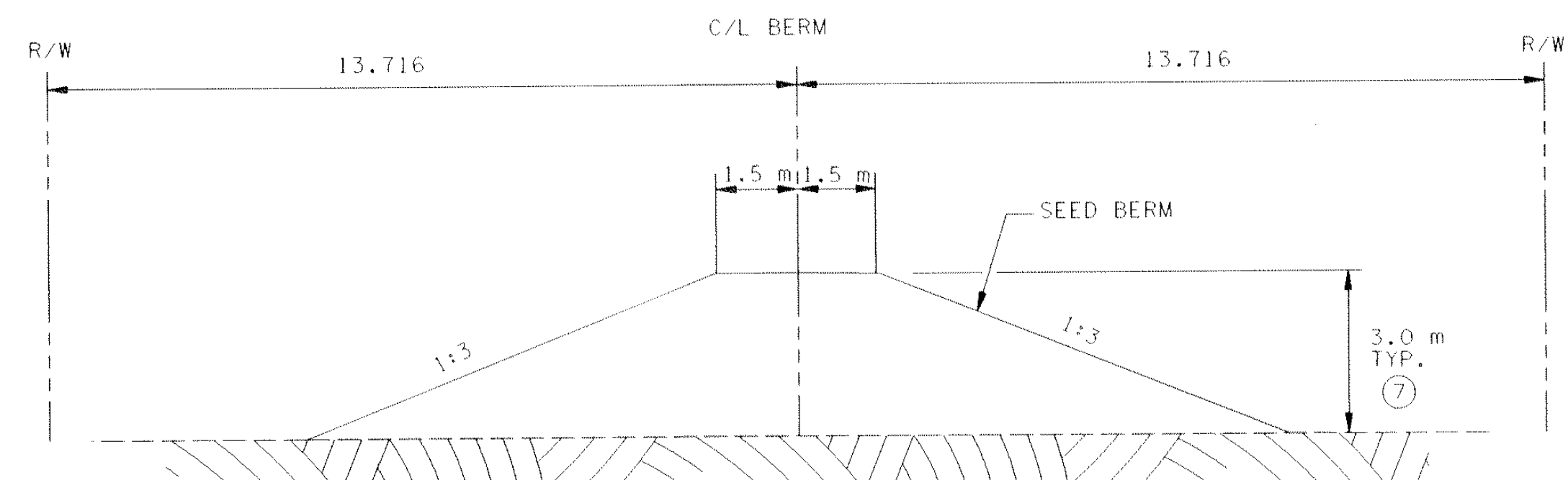

BERM
TYPICAL SECTION

NOTES:

- ① SEE CROSS SECTIONS FOR LOCATIONS OF VARIABLE SLOPES AND DITCH WIDTHS
- ④ SEE TURF ESTABLISHMENT PLANS FOR SOD AND SEED AREAS
- ⑦ BERM SHAPE IS VARIABLE AND DEPENDANT ON QUANTITY OF EXCESS TOPSOIL MATERIAL. BERM HEIGHT AND LENGTH WILL BE STAKED IN THE FIELD BY THE ENGINEER.

DESIGN FILE: m:\civil\1047\2953\2953.tsb
 PLOT FILE: m:\civil\1047\2953\2953.drf
 PLOTTER: HP-DesignJet-Model-FF-MnDOT
 PLOT DATE: 08/29/98 13:21:57

NO	DATE	BY	CKD	APPR	REVISION

NAME: 2953.TSB DATE: May, 19, 1998 TIME: 10:51:24



I hereby certify that this plan, specification or report was prepared by me or under my direct supervision and that I am a duly Registered Professional Engineer under the laws of the State of Minnesota.
M. Hansen
 Date 6-25-98 Reg No. 21364

COUNTY PROJ. NO.
95-05-116
CITY PROJECT NO.
97-25
DRAWN BY
W. ANDERSON
DATE 3-98
DESIGNED BY
B. URBANEK
3-98
CHECKED BY
M. HANSEN
5-98
COMM. NO.
0982953



ANOKA COUNTY
TYPICAL SECTIONS
C.R. 116

SHEET
9
OF
59

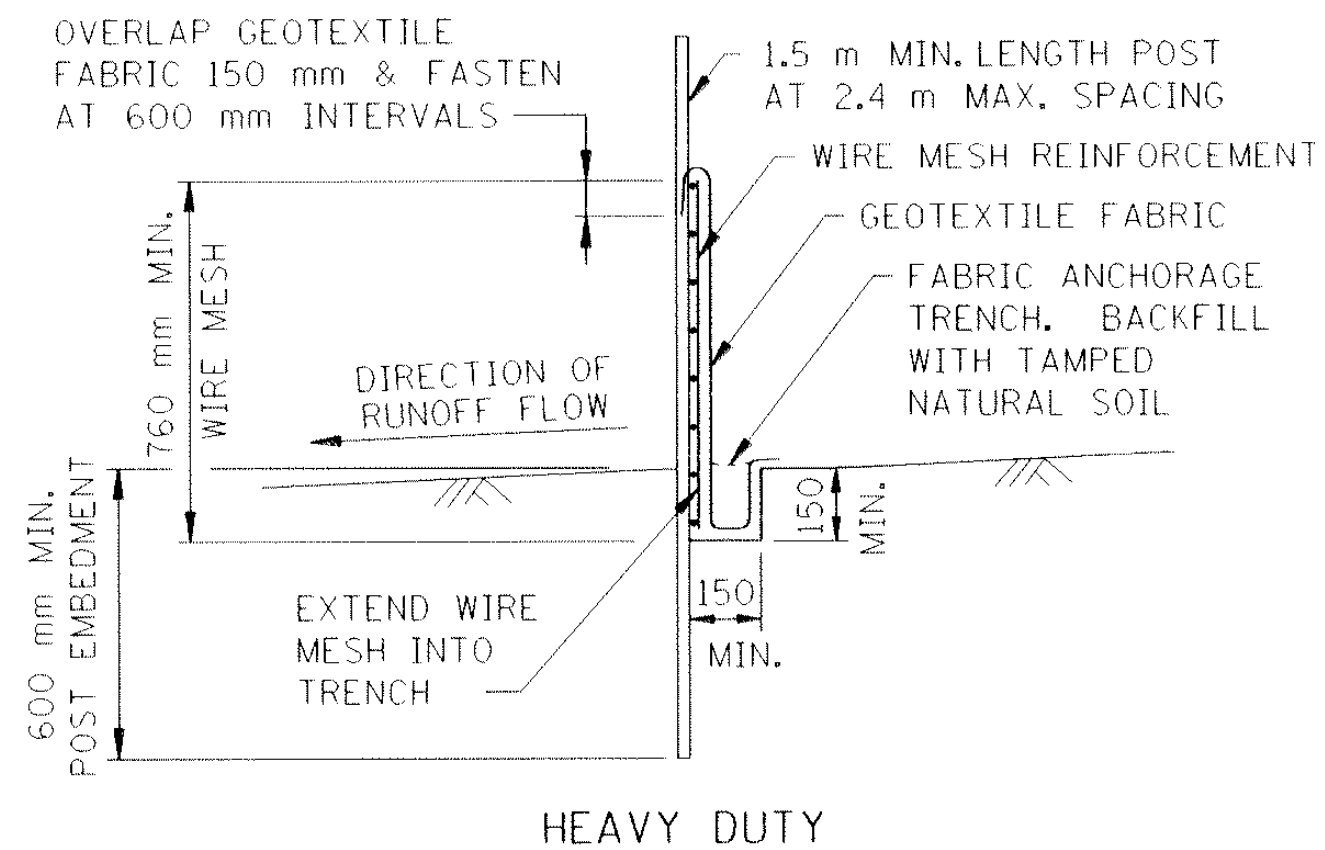

HEAVY DUTY

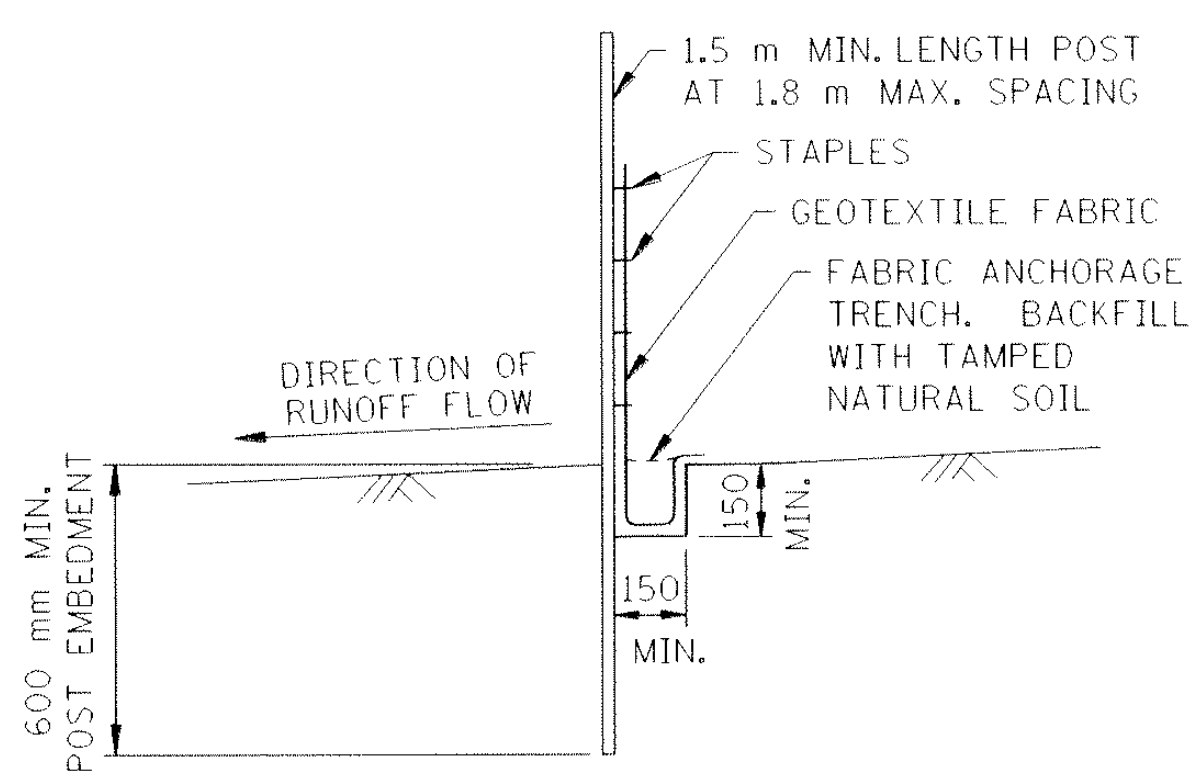

SELF SUPPORTING

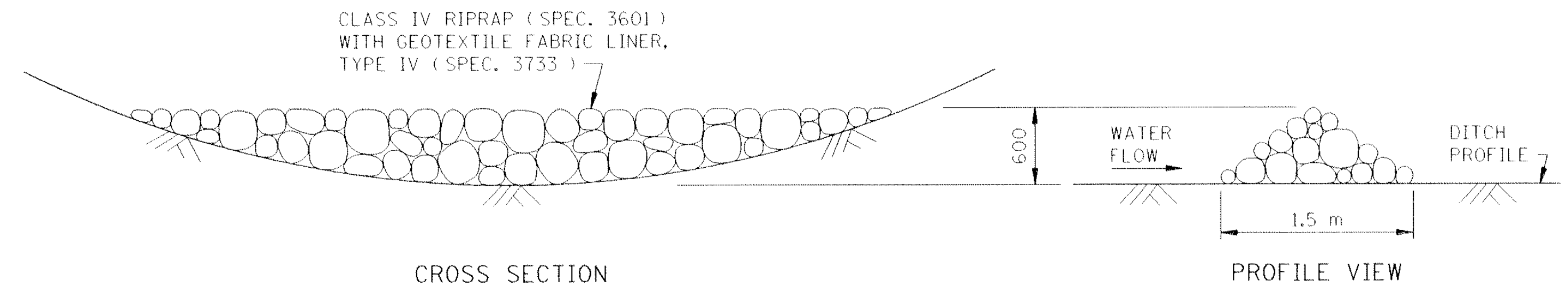

ROCK DITCH CHECK

SILT FENCE DETAILS
TO PROTECT AREAS FROM SHEET FLOW
(SEE SPEC. 3886)

DESIGN CRITERIA:
MAXIMUM CONTRIBUTING AREA: 1.2 ha

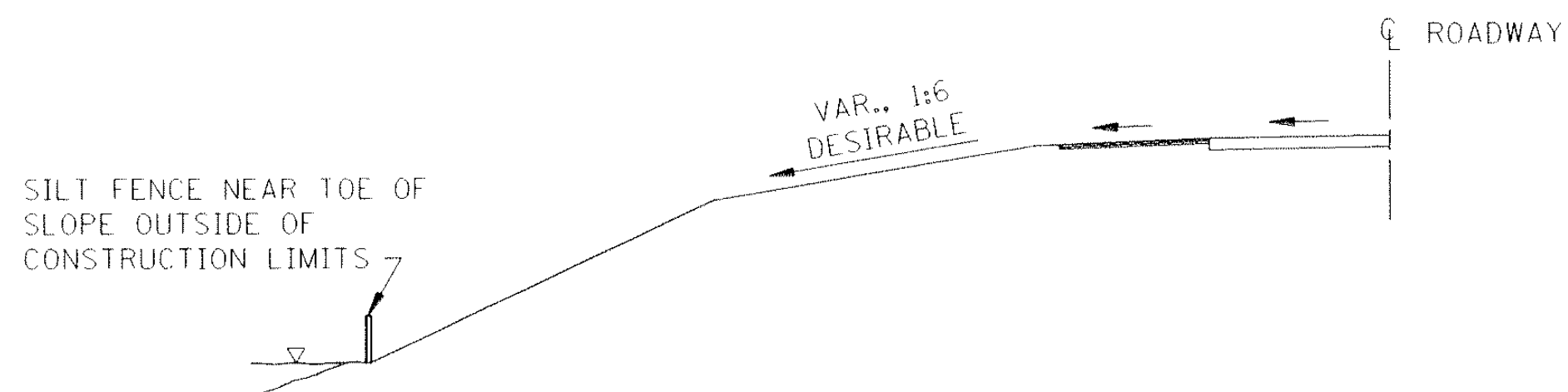

ROADWAY EMBANKMENT

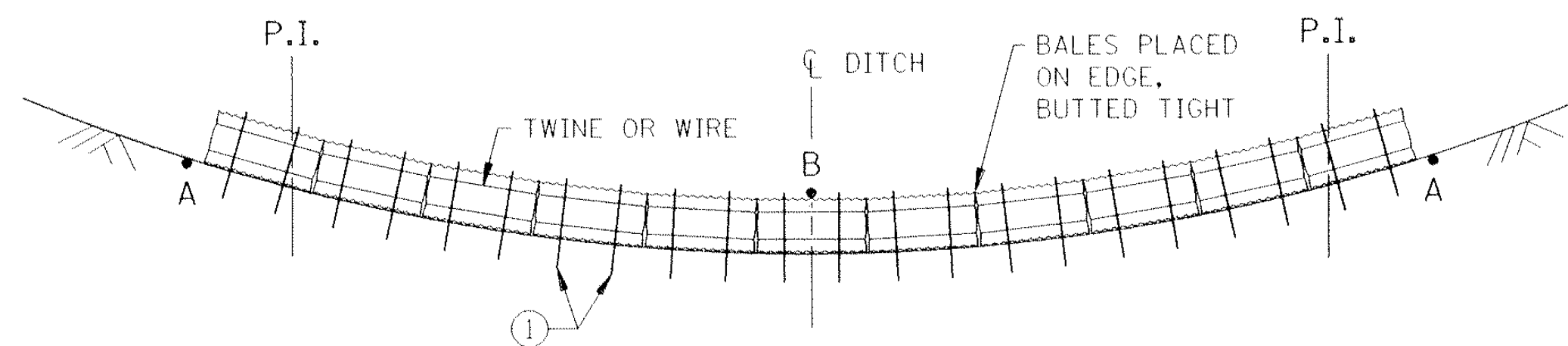

NOTE:
POINT A MUST BE HIGHER THAN POINT B

BALE DITCH SEDIMENT CHECK

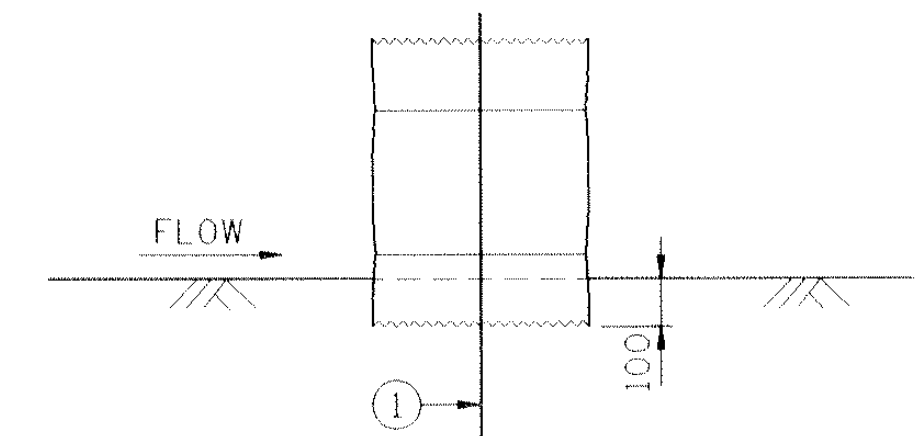

BALE CHECK DETAIL

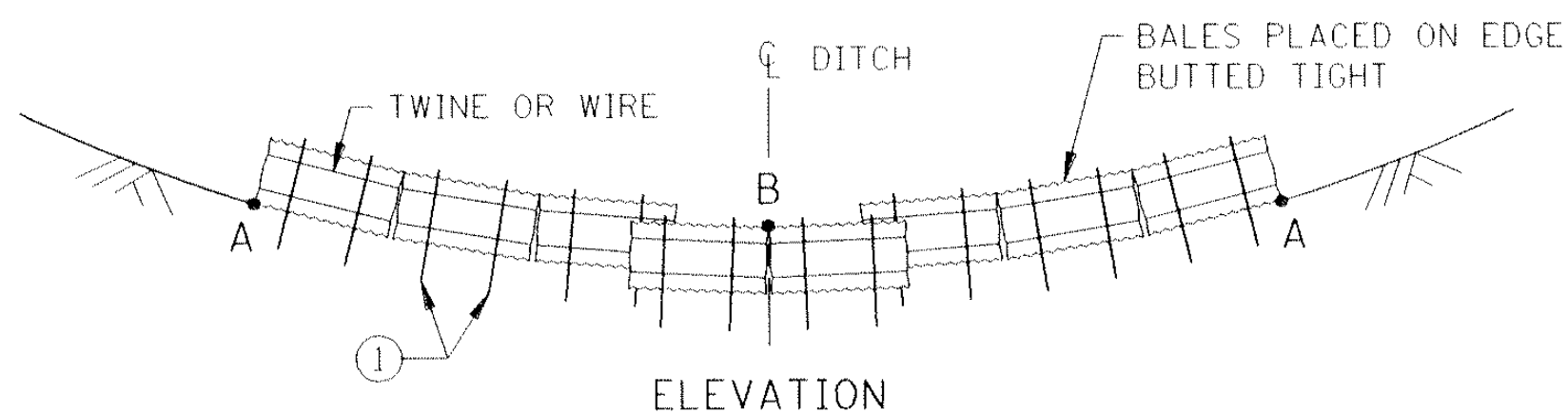
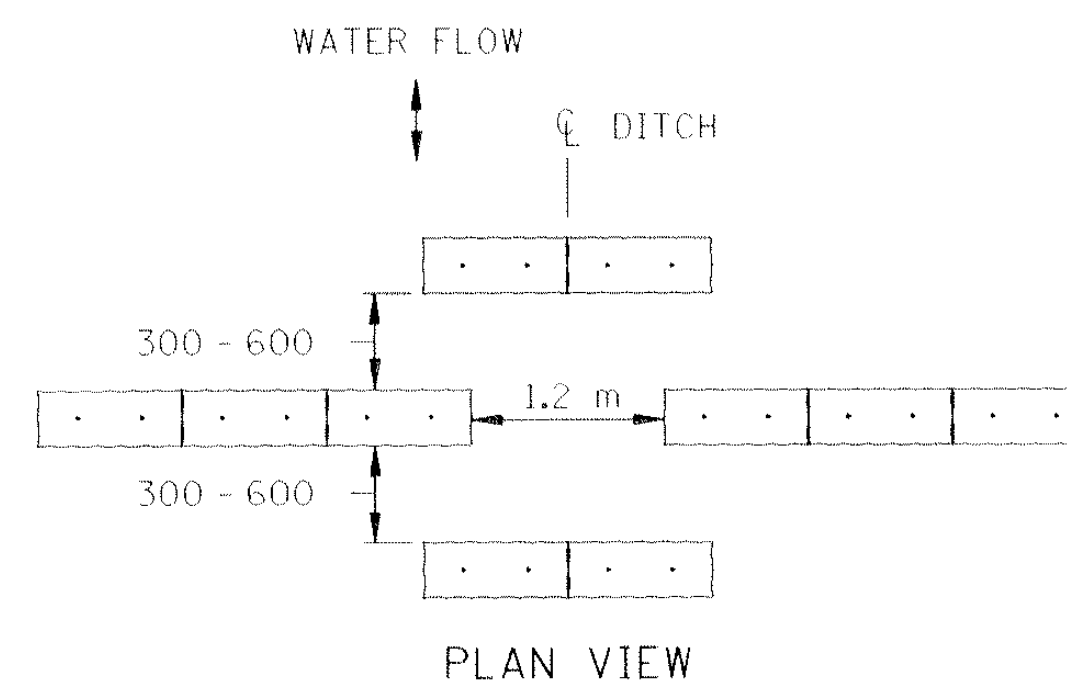

NOTE:
POINT A MUST BE HIGHER THAN POINT B

BALE DITCH VELOCITY CHECKS
(WILL REQUIRE A MINIMUM OF 10 BALES PER SITE)

RECOMMENDED SPACING BETWEEN DITCH CHECKS	
DITCH GRADE (%)	SPACING (m)
2	30
4	23
6	15
8	12
10	8

DESIGN CRITERIA:

	BALE	ROCK
STORM FREQUENCY:	2 YR. - 24 HR.	10 YR. - 24 HR.
MAX. FLOW VELOCITY:	1.5 m/SEC.	3.6 m/SEC.
MAX. DITCH GRADE:	5%	—
MAX. DRAINAGE AREA:	0.8 ha	2.0 ha

NOTE:
① TWO 50 mm X 50 mm WOOD STAKES OR REINFORCING BARS IN EACH BALE AND EMBEDDED IN THE GROUND 250 mm MINIMUM.

NOTE: ALL DIMENSIONS ARE IN MILLIMETERS, EXCEPT AS NOTED.

STANDARD SHEET NO. 5-297.405M (2 OF 3)	TITLE: TEMPORARY EROSION CONTROL
STANDARD APPROVED: MAY 1, 1995	
COUNTY PROJ. NO. 95-05-116	SHEET NO. 10 OF 59 SHEETS

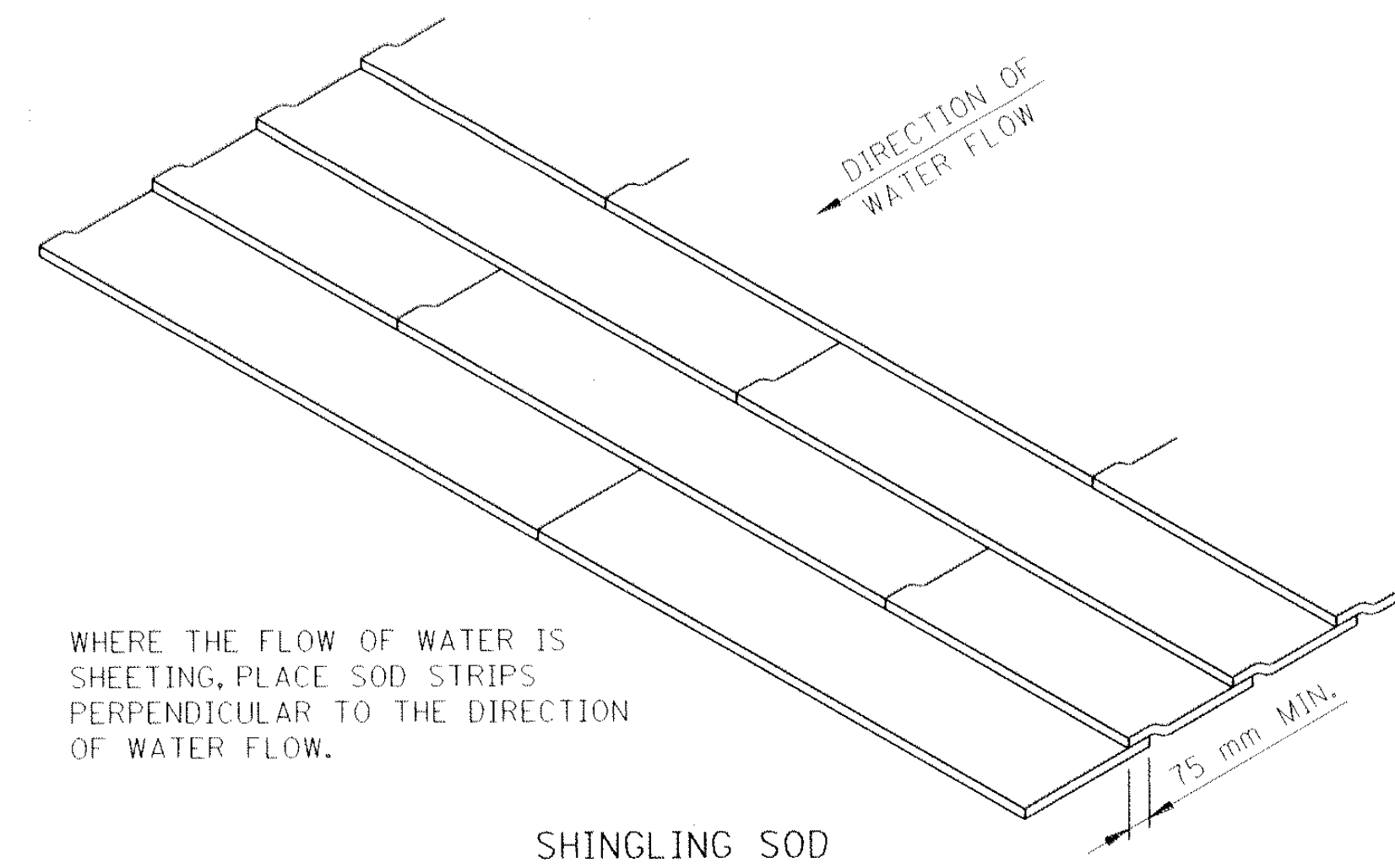
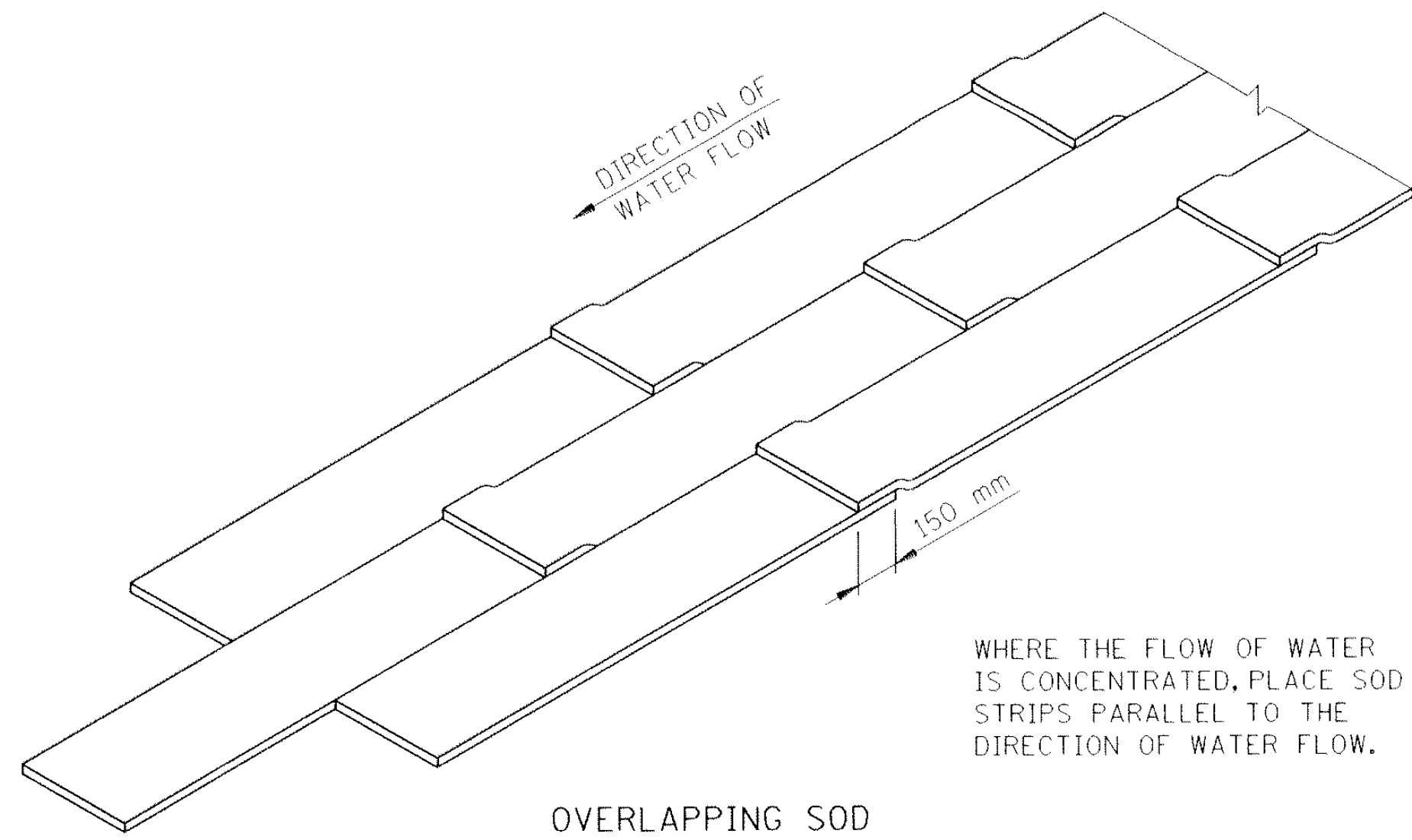

SPECIAL SOD PLACEMENT TECHNIQUES

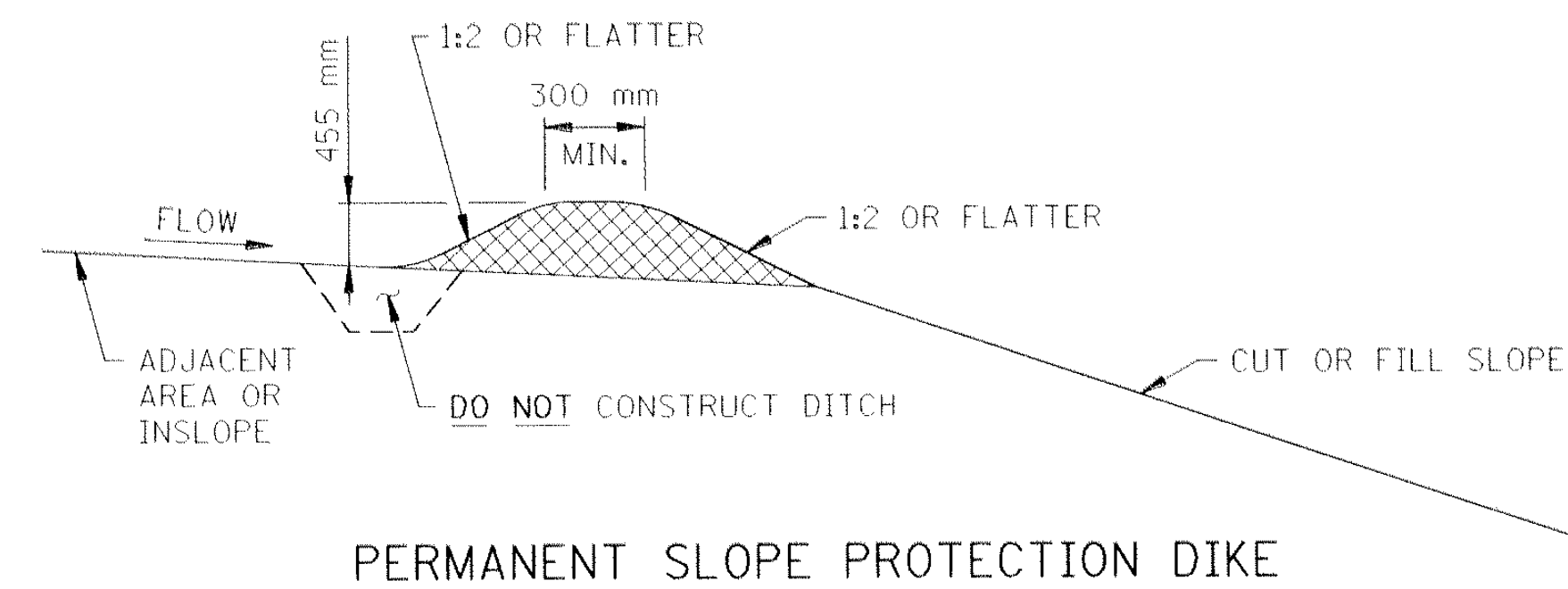
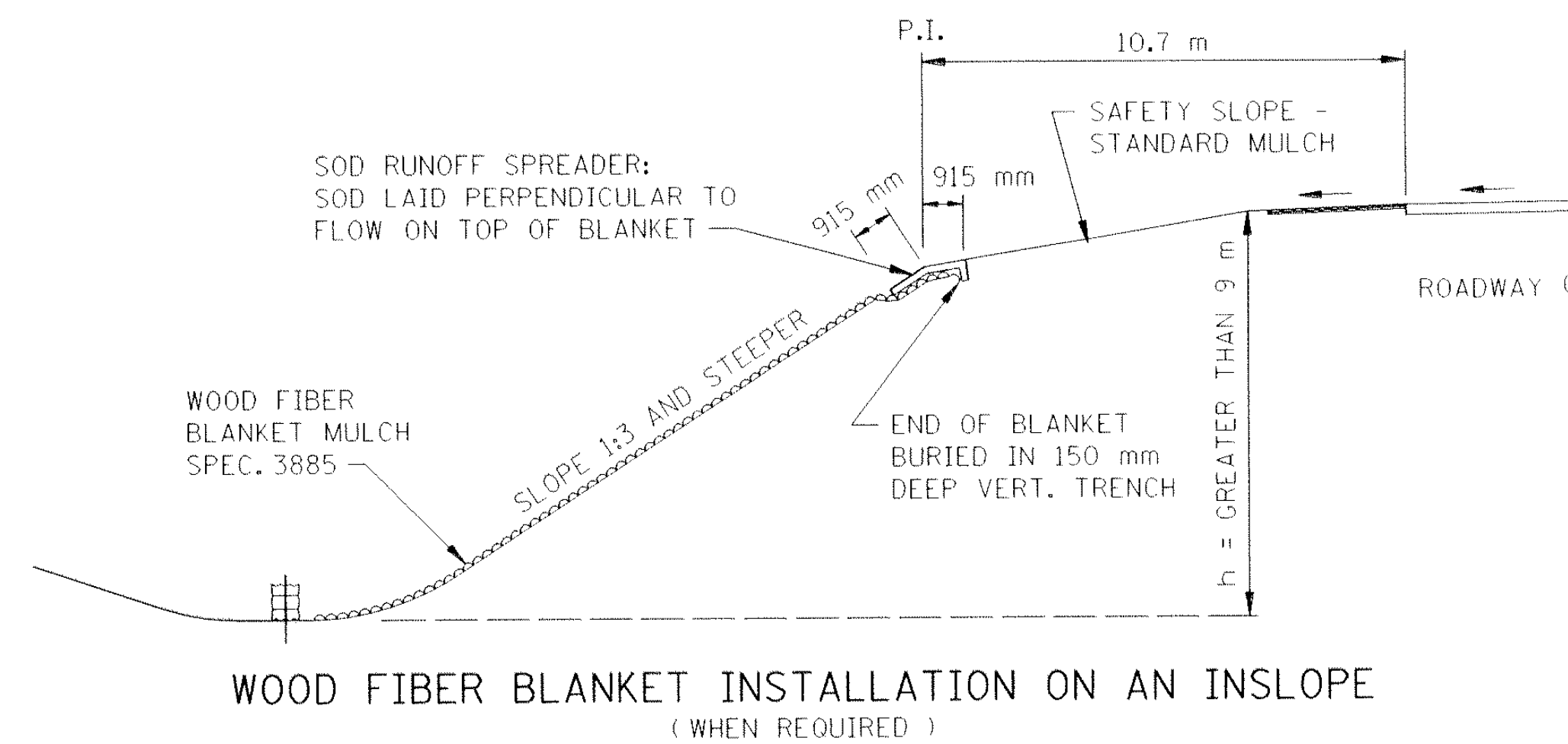
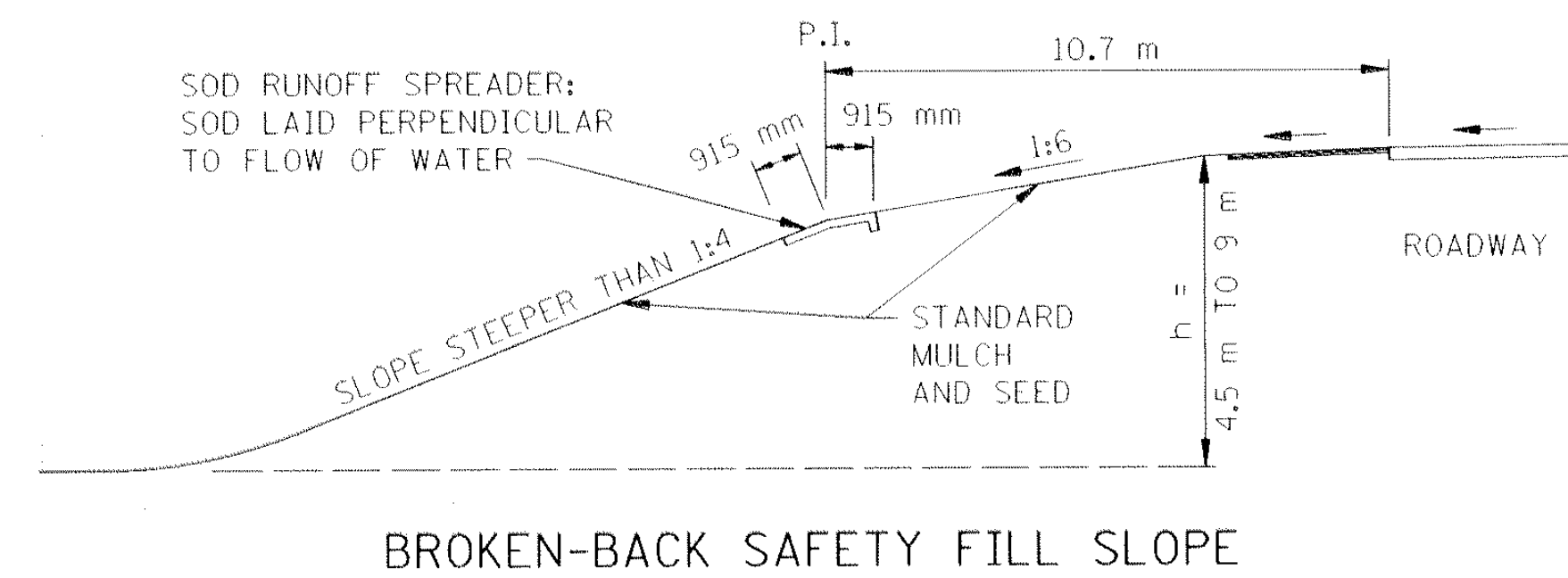
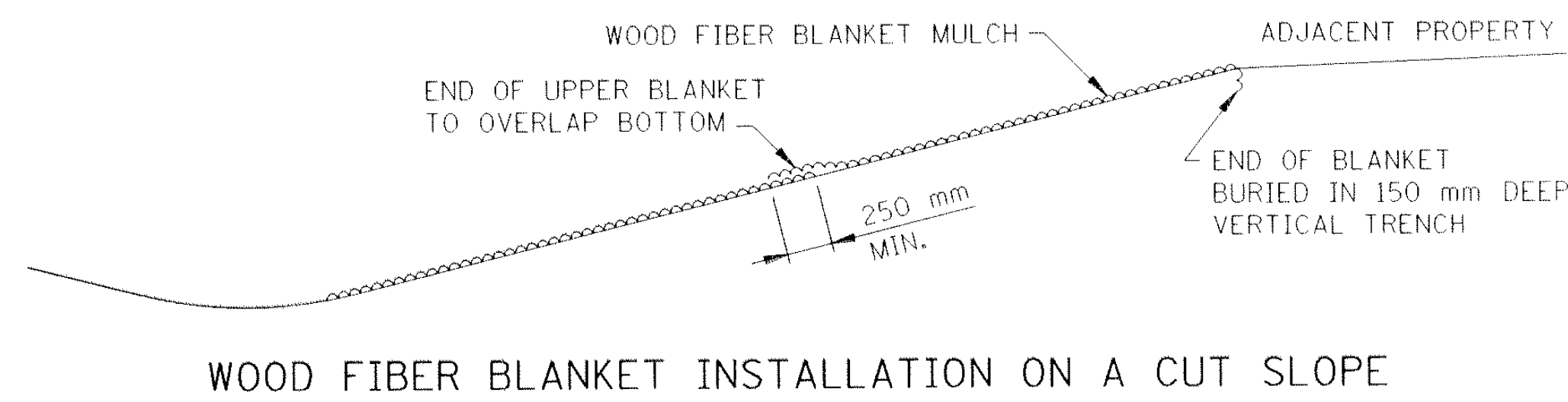

STANDARD SHEET NO. 5-297.406M	TITLE: PERMANENT EROSION CONTROL ALONG ROADWAYS AND AT GORE AREAS & BRIDGE APPROACH FILLS
STANDARD APPROVED: JANUARY 31, 1985	
COUNTY PROJ. NO. 95-05-116	SHEET NO. 11 OF 59 SHEETS

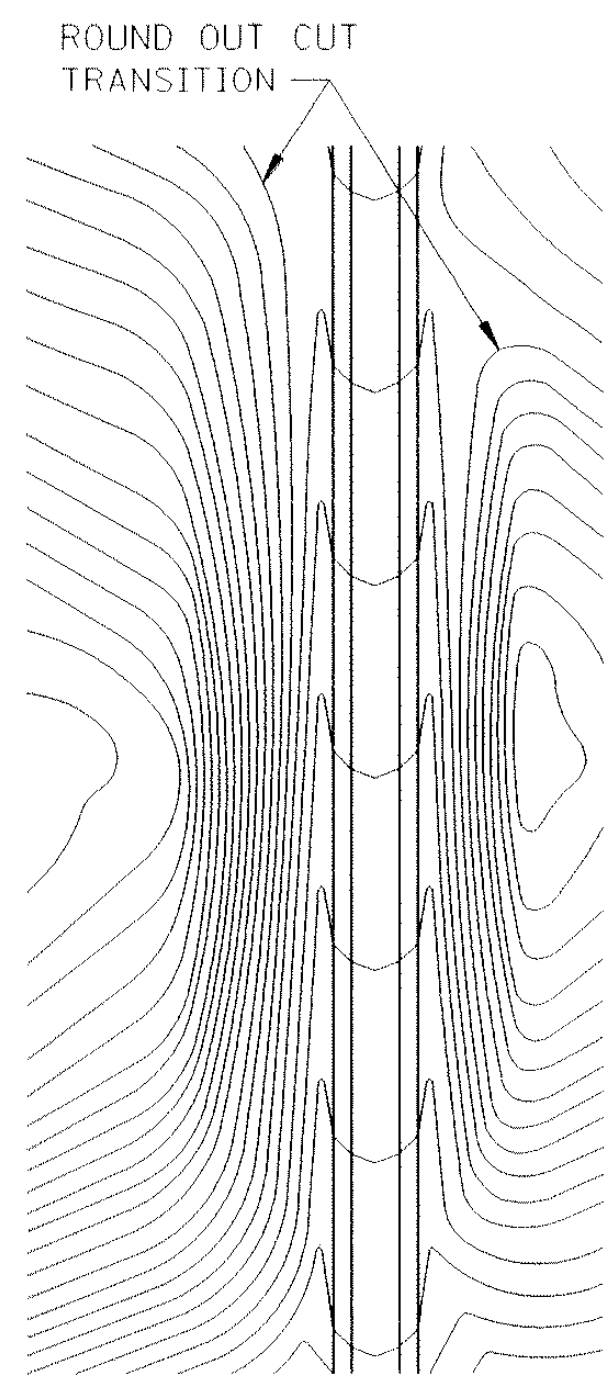

CONTOURING ROAD CUTS

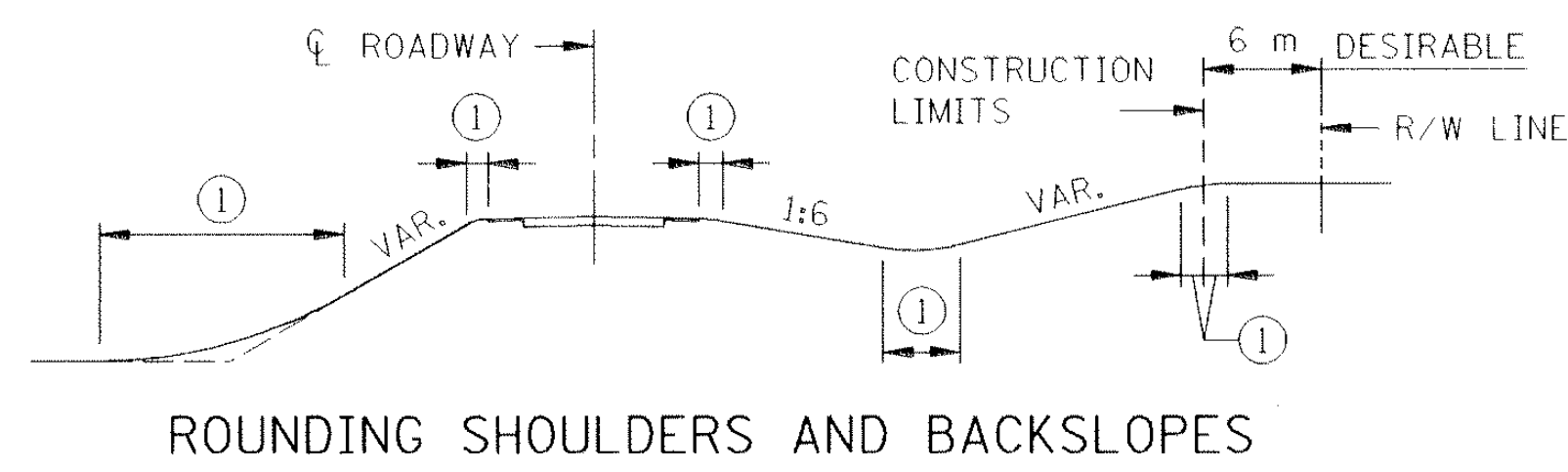

ROUNDING SHOULDERS AND BACKSLOPES

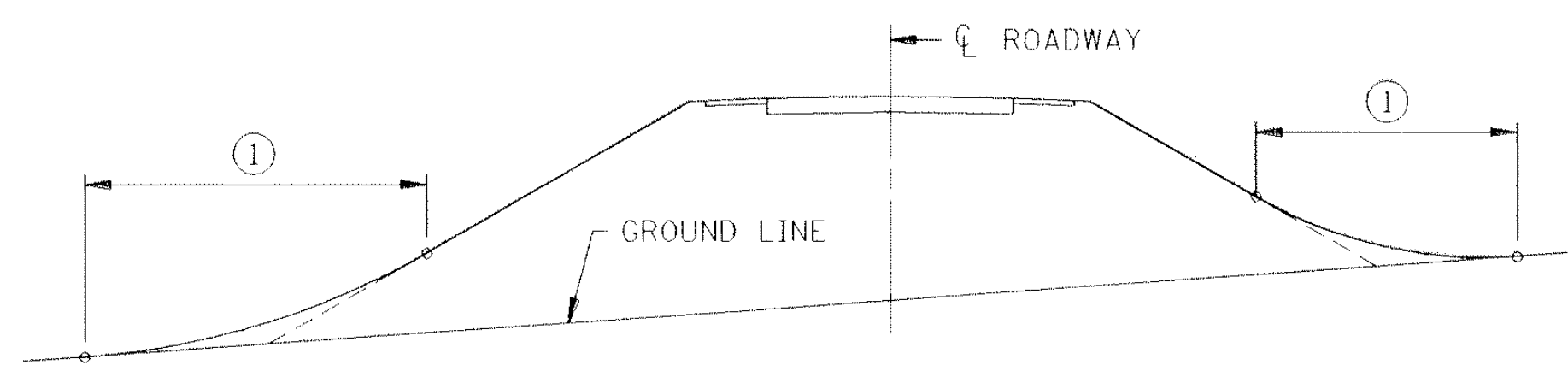

SHAPING FOR DRAINAGE ALONG THE TOE OF FILL SLOPES

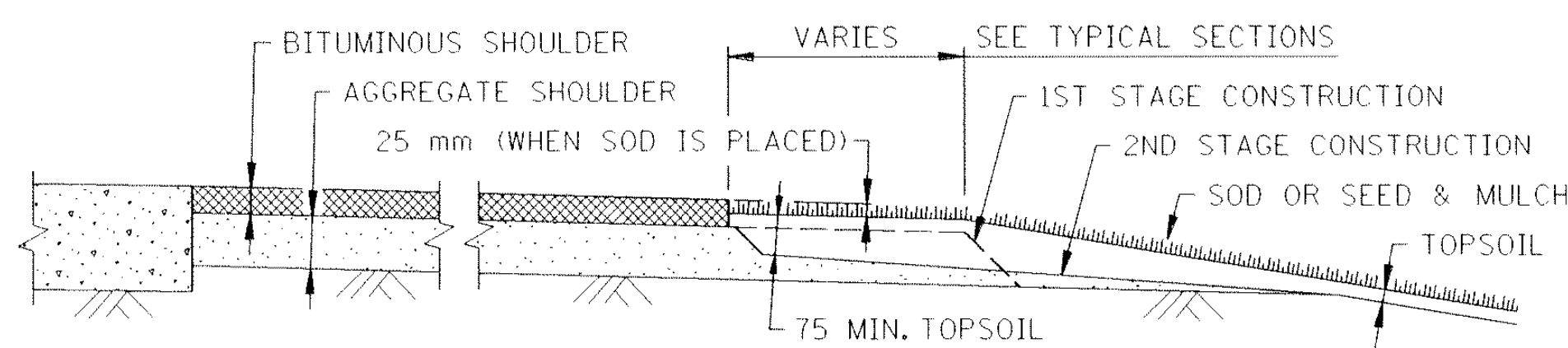

SHAPING AND TOPSOILING INSLOPES

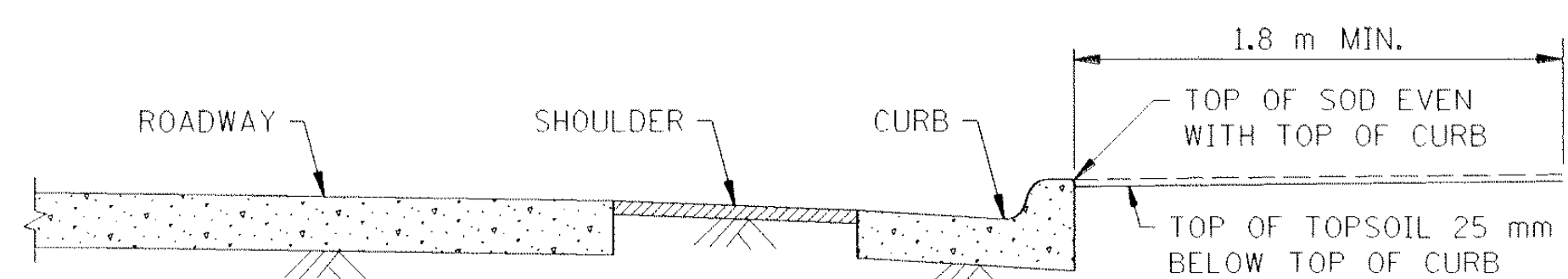

SHAPING ADJACENT TO CURBS WHEN SOD IS PLACED

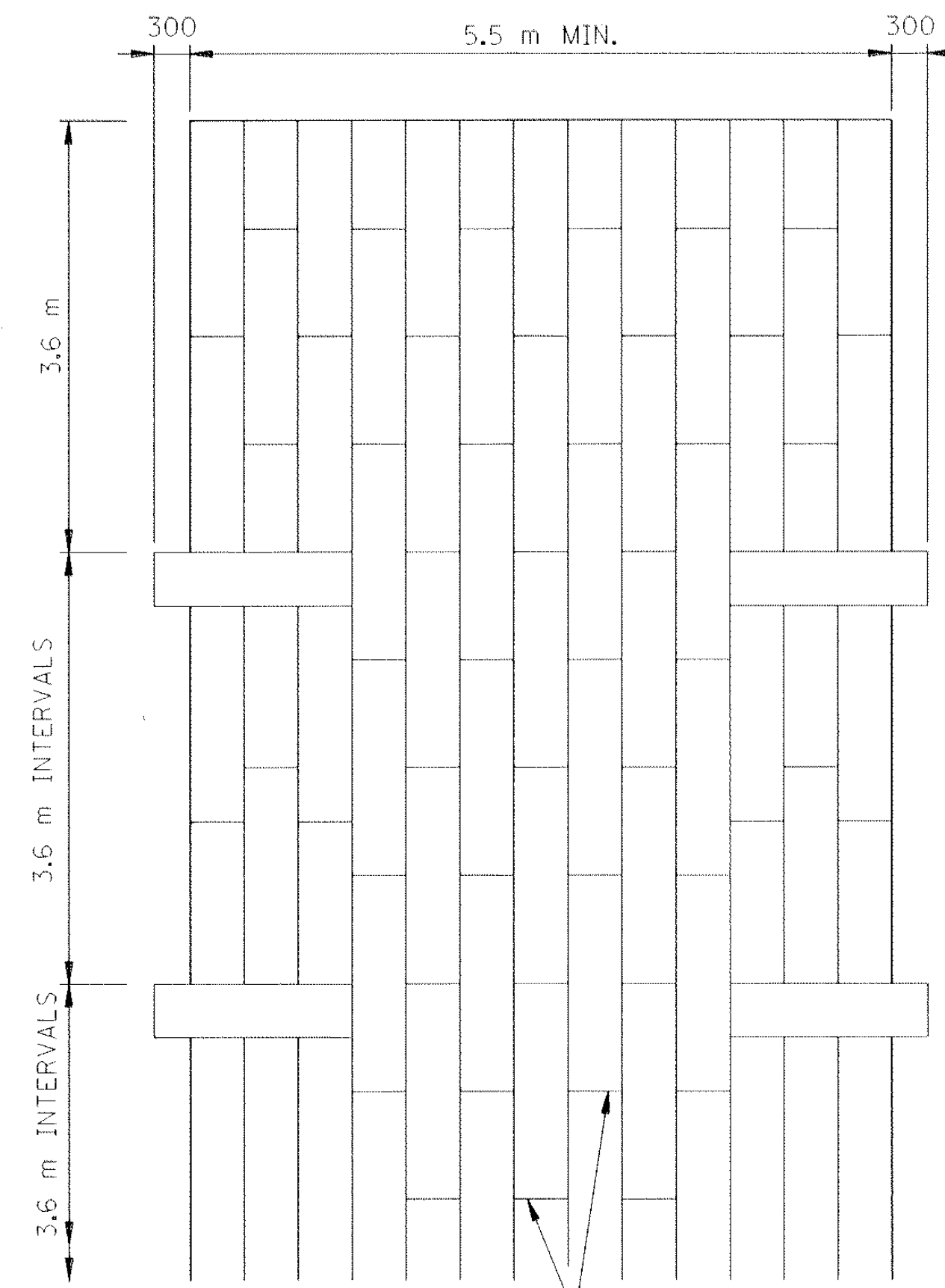

STAGGER JOINTS
PLAN VIEW

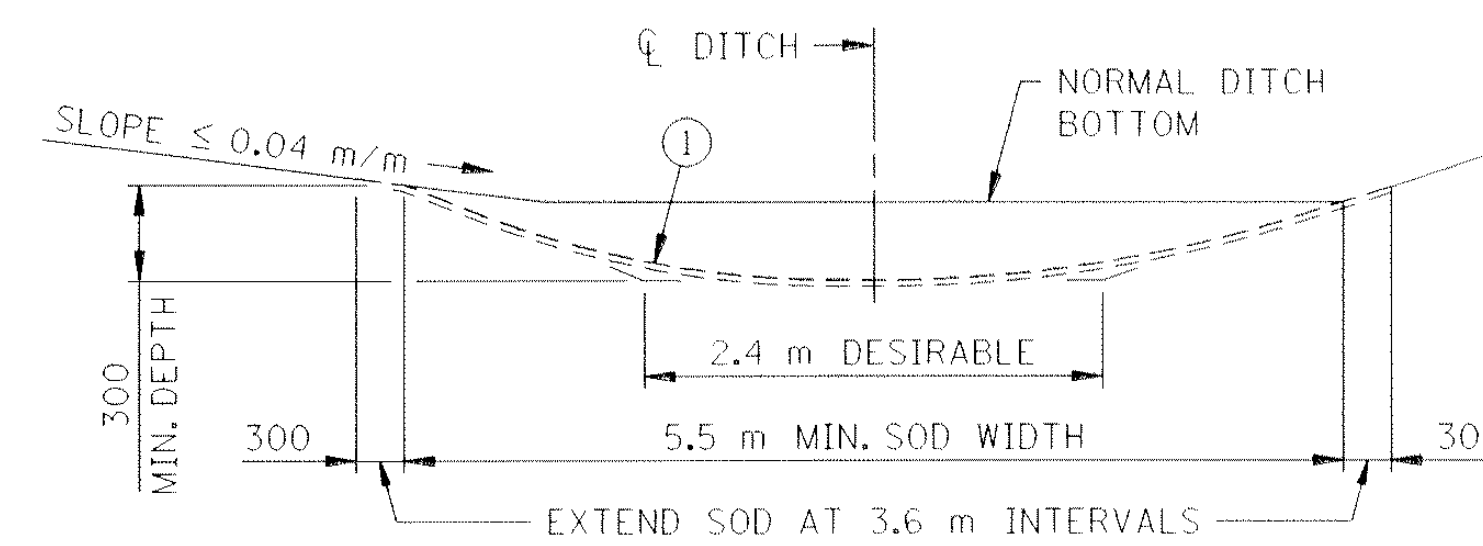

SODDED DITCH CROSS SECTION
WHERE FRONT OR BACK SLOPE IS FLAT (LESS THAN 0.04 m/m), FIRST NOTCH DITCH AND THEN PROVIDE ROUNDING.

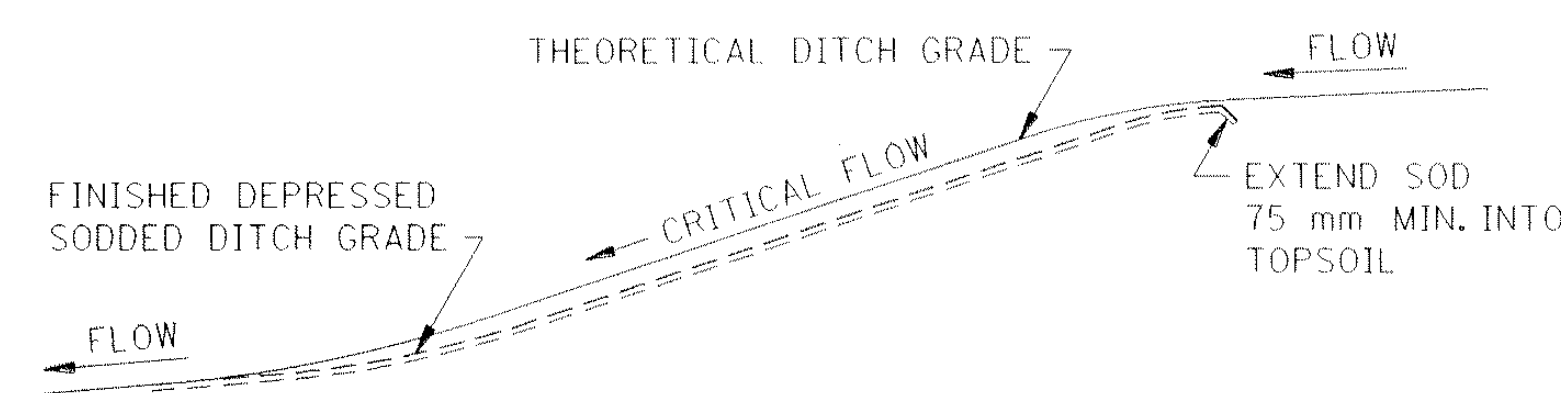

DITCH PROFILE
SODDED DITCH DETAILS

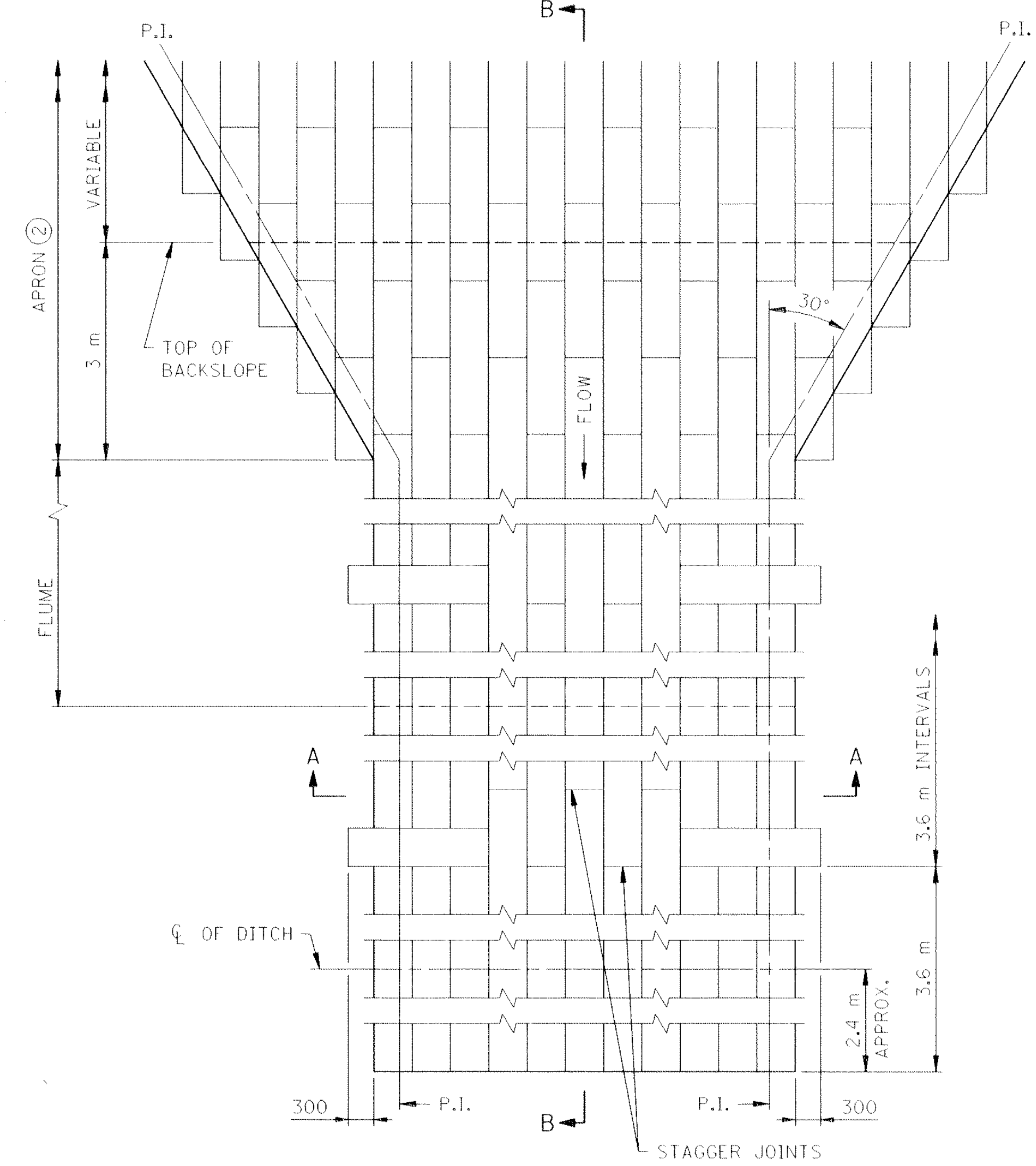

PLAN VIEW

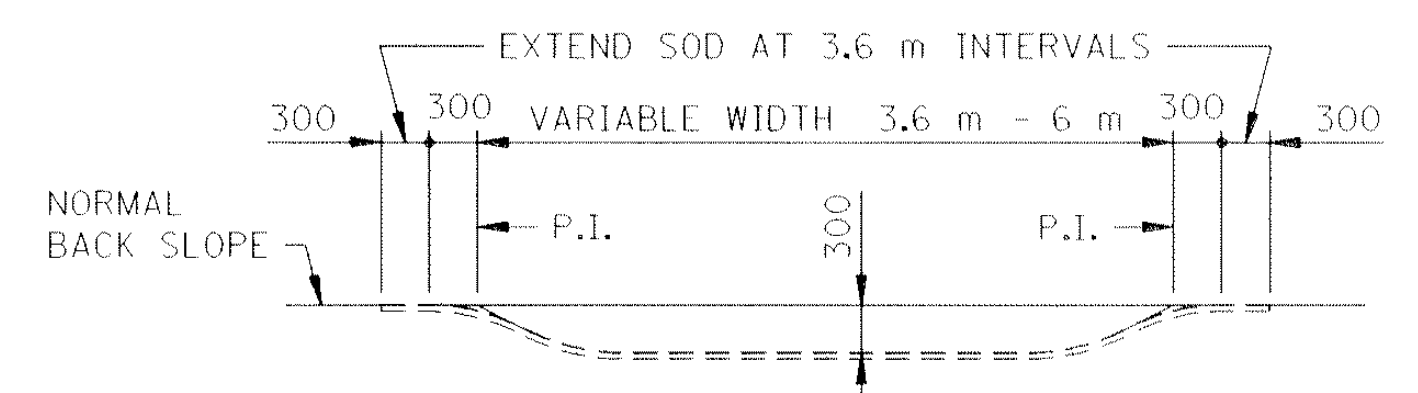

SECTION A-A

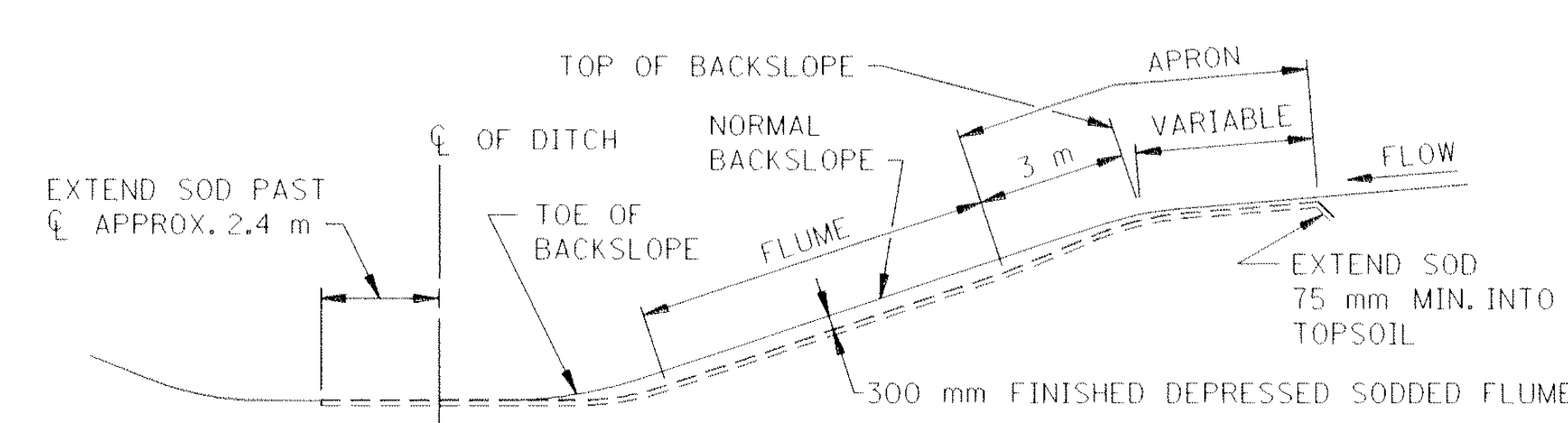

SECTION B-B

SODDED FLUME DETAILS

NOTE: ALL DIMENSIONS ARE IN MILLIMETERS, EXCEPT AS NOTED.

- NOTES:
 SEE SPEC. 2575.3 FOR ADDITIONAL INFORMATION.
 ① FOR ROUNDING, SEE ROAD DESIGN MANUAL.
 ② CONSTRUCT TAPER AS DIRECTED BY THE ENGINEER.

STANDARD SHEET NO. 5-297.404M	TITLE:
STANDARD APPROVED: DECEMBER 19, 1990	PERMANENT EROSION CONTROL ALONG ROADWAYS, DITCHES AND FLUMES

COUNTY PROJ. NO. 95-05-116

SHEET NO. 12 OF 59 SHEETS

SERVER C:\64SI\USR\STANDARDS FILE NAME SM404L90.SPN 26711.STA

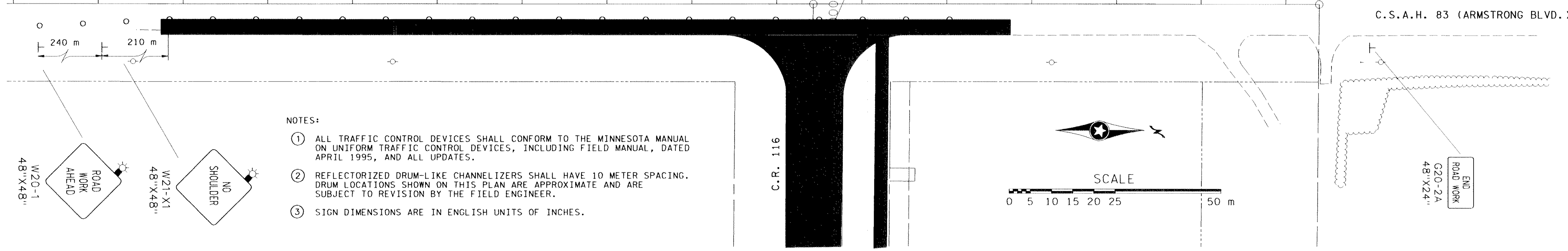
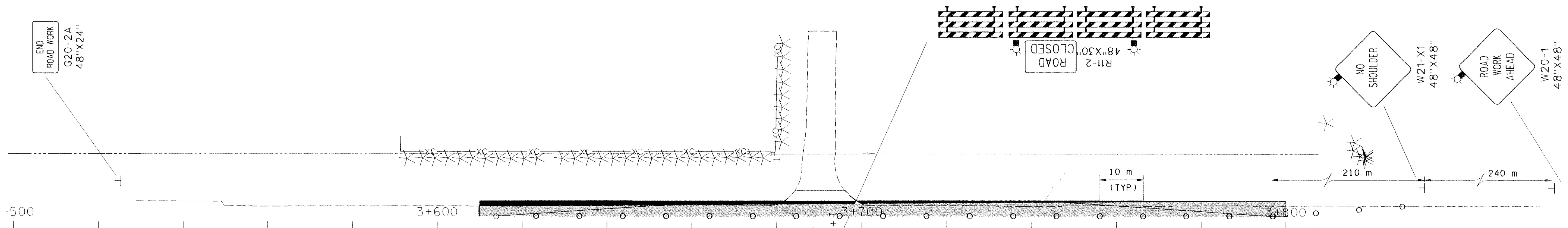

NOTES:

- ① ALL TRAFFIC CONTROL DEVICES SHALL CONFORM TO THE MINNESOTA MANUAL ON UNIFORM TRAFFIC CONTROL DEVICES, INCLUDING FIELD MANUAL, DATED APRIL 1995, AND ALL UPDATES.
- ② REFLECTORIZED DRUM-LIKE CHANNELIZERS SHALL HAVE 10 METER SPACING. DRUM LOCATIONS SHOWN ON THIS PLAN ARE APPROXIMATE AND ARE SUBJECT TO REVISION BY THE FIELD ENGINEER.
- ③ SIGN DIMENSIONS ARE IN ENGLISH UNITS OF INCHES.

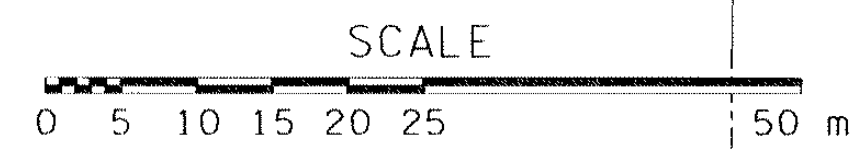

LEGEND	
	TYPE A LOW INTENSITY FLASHER
	STANDARD SIGN (POST OR STAND MOUNT)
	REFLECTORIZED DRUM-LIKE CHANNELIZING DEVICE
	TYPE 3 BARRICADE - REFLECTORIZED BOTH SIDES

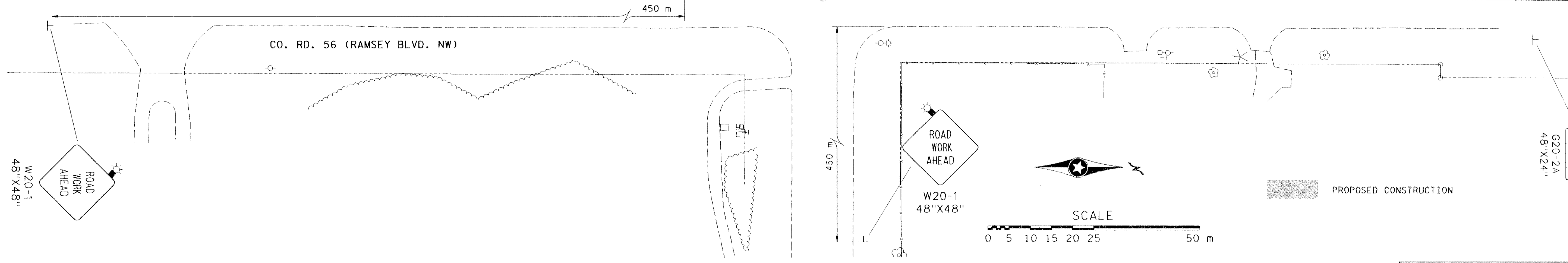
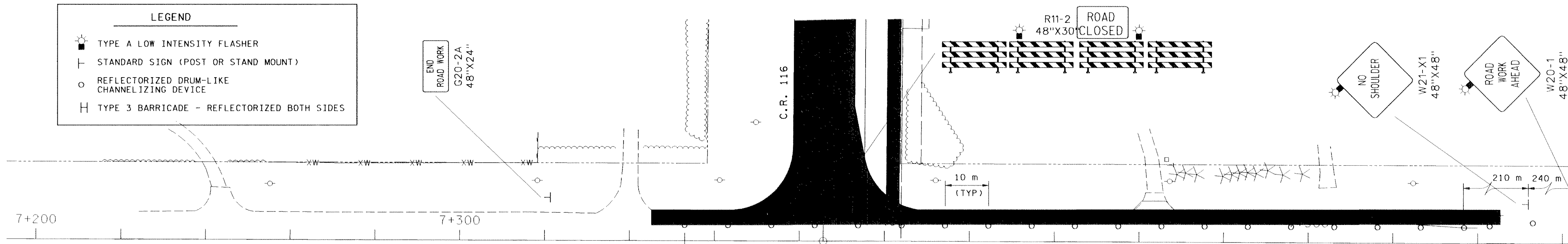

DESIGN FILE: P:\GIS\11\047\2953\2953.dwg
 PLOT FILE: P:\GIS\11\047\2953\2953.plt
 PLOTTER: MS-DOS/HP-GL/4+Mono-FR-MNDOT
 PLOT SCALE: 12:7000000
 PLOT DATE/TIME: 06/23/98 13:17:30

NO.	DATE	BY	CHKD	APPR	REVISION

NAME: 2953.HA DATE: May 20, 1998 TIME: 09:51:05



I hereby certify that this plan, specification or report was prepared by me or under my direct supervision and that I am a duly Registered Professional Engineer under the laws of the State of Minnesota.

M. Hansen
 Date: 6-25-98 Reg. No. 21364

COUNTY PROJ. NO.
95-05-116

CITY PROJECT NO.
97-25

DRAWN BY
W. ANDERSON 3-98

DESIGNED BY
K. JULIE 5-98

CHECKED BY
M. HANSEN 5-98

COMM. NO.
0982953



ANOKA COUNTY
 TRAFFIC CONTROL PLAN
 C.R. 116

SHEET
13
OF
59

POINT NO.	POINT	STATION	CURVE DATA				COORDINATES		AZIMUTH
			DELTA	RADIUS	TANGENT	LENGTH	X	Y	
C.R. 116									
1001	POT	C/L C.R. 116					7,468.8634	4,953.9313	90° 31' 02.1"
	A PT.	ON C/L C.S.A.H. 83							
	PC						7,621.2576	4,952.5554	
116-1	PI		42° 49' 34.9" RT	335.000	131.374	250.399	7,752.6262	4,951.3694	PI
	CC						7,618.2333	4,617.5691	133° 20' 37.0"
	PT						7,848.1680	4,861.1980	
	PC						7,981.1611	4,735.6803	
116-2	PI		42° 49' 33.3" LT	335.000	131.372	250.397	8,076.7018	4,645.5100	PI
	CC						8,211.0958	4,979.3093	90° 31' 03.7"
	PT						8,208.0689	4,644.3229	
1000	POT	C/L C.R. 116					9,083.8540	4,636.4095	
	A PT.	ON C/L C.R. 56							
1004							7,611.1000	4,934.3590	
1005							7,610.9810	4,725.7090	
1006							7,758.1280	4,724.3810	
1007							7,617.1910	4,925.6600	
1008							7,617.1960	4,934.3040	
1009							7,716.8440	4,783.3410	
1010							7,725.5850	4,770.8570	
1011							7,835.6140	4,847.9000	
1012							7,823.9730	4,858.3540	
C.S.A.H. 83									
10008	POT						7,468.4680	4,265.3208	0° 01' 58.4"
10000	POT	N.W. CORNER SECTION 28					7,468.9319	5,073.2302	
C.R. 56									
10003	POT						9,082.5883	4,250.7905	0° 11' 17.0"
10002	POT	N.E. CORNER SECTION 28					9,085.2398	5,058.6044	

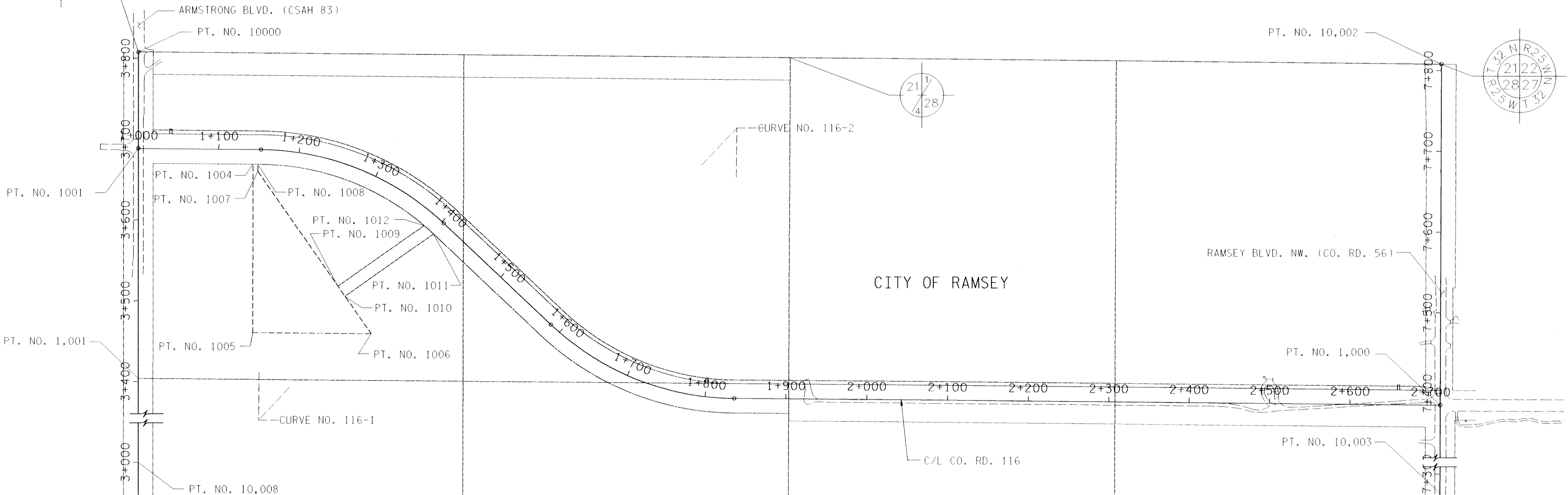
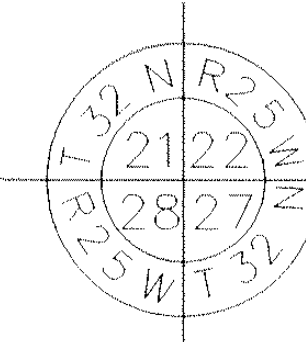
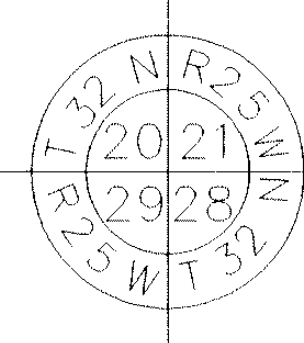
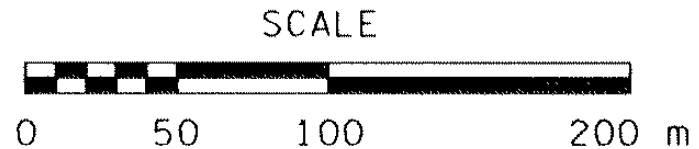

NO.	DATE	BY	CHKD	APPR	REVISION

NAME: 295.3 APA DATE: May. 20, 1998 TIME: 16:00:00



I hereby certify that this plan, specification or report was prepared by me or under my direct supervision and that I am a duly Registered Professional Engineer under the laws of the State of Minnesota.

M. Hansen
Date: 6-25-98 Reg. No. 21364

COUNTY PROJ. NO.
95-05-116

CITY PROJECT NO.
97-25

DRAWN BY
W. ANDERSON

DESIGNED BY
B. URBANEK

CHECKED BY
M. HANSEN

DATE
3-98

DATE
3-98

DATE
5-98

COMM. NO.
0982953



ANOKA COUNTY

ALIGNMENT PLAN & TABULATION

C.R. 116

SHEET
14
OF
59

NOTES:
 PAVEMENT CROSS SLOPES ARE METER PER METER.
 DITCH GRADE ELEVATIONS ARE SHOWN TO BOTTOM OF TOPSOIL (BTS)

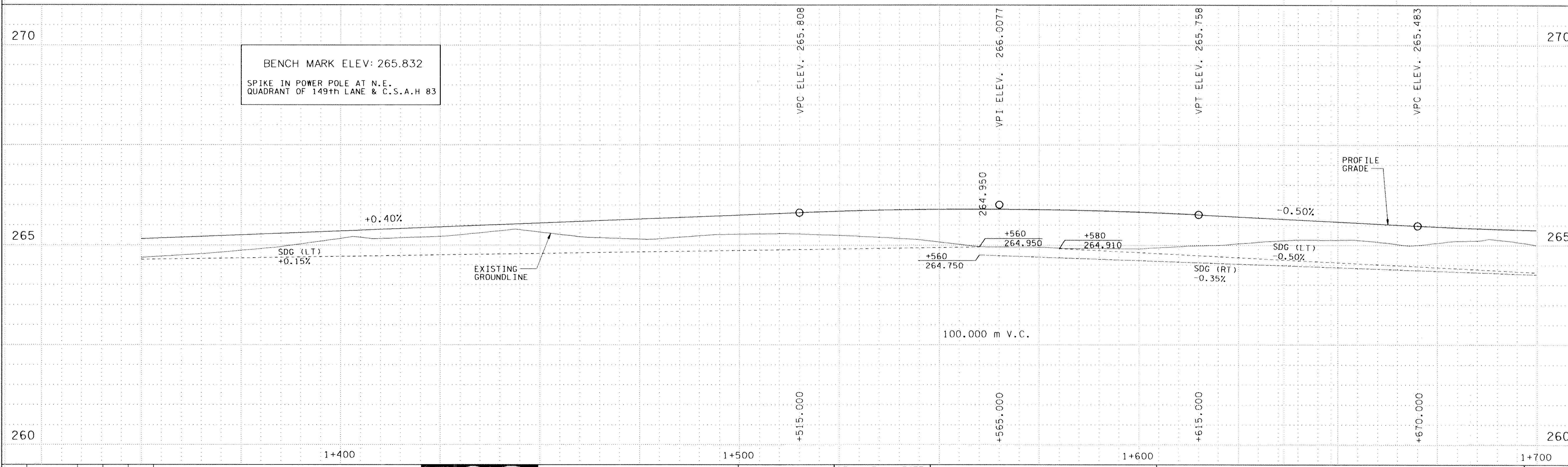
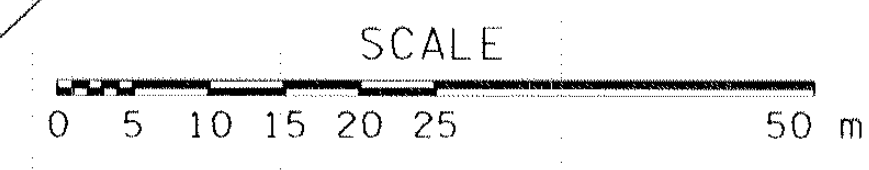
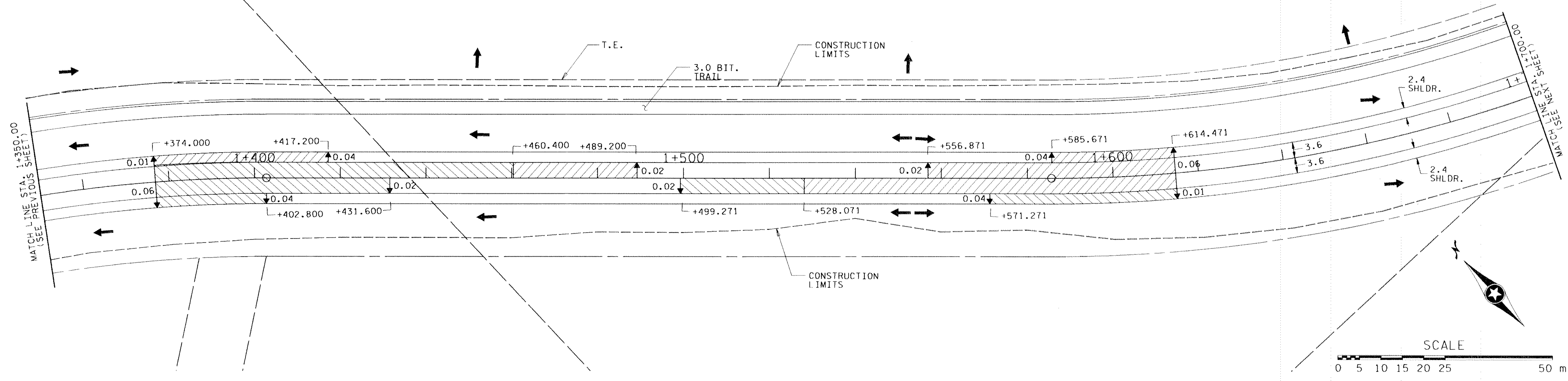

DESIGN FILE: P:\CIVIL\047\2953\2953.dwg
 PLOT FILE: P:\CIVIL\047\2953\2953.plt
 PLOTTER: MS-DesignJet-Mono-FR-MIDOT
 PLOT SCALE: 1:1
 PLOT DATE/TIME: 06/23/98 13:23:22

NO.	DATE	BY	CHKD	APPR	REVISION
NAME: 2953.CPB DATE: May. 20, 1998 TIME: 11:55:52					



I hereby certify that this plan, specification or report was prepared by me or under my direct supervision and that I am a duly Registered Professional Engineer under the laws of the State of Minnesota.

Walter D. Hansen
 Date: 6-25-98 Reg. No. 21364

COUNTY PROJ. NO. 95-05-116
 CITY PROJECT NO. 97-25

DRAWN BY W. ANDERSON DATE 3-98
 DESIGNED BY B. URBANEK 3-98
 CHECKED BY M. HANSEN 5-98
 COMM. NO. 0982953



ANOKA COUNTY
 CONSTRUCTION PLAN & PROFILE
 C.R. 116
 STA. 1+350 TO STA. 1+700

SHEET 16 OF 59

NOTES:

PAVEMENT CROSS SLOPES ARE METER PER METER.

DITCH GRADE ELEVATIONS ARE SHOWN TO BOTTOM OF TOPSOIL (BTS)

CLEAR AND GRUB TREES WITHIN CONSTRUCTION LIMITS, SEE TAB X SHEET X.

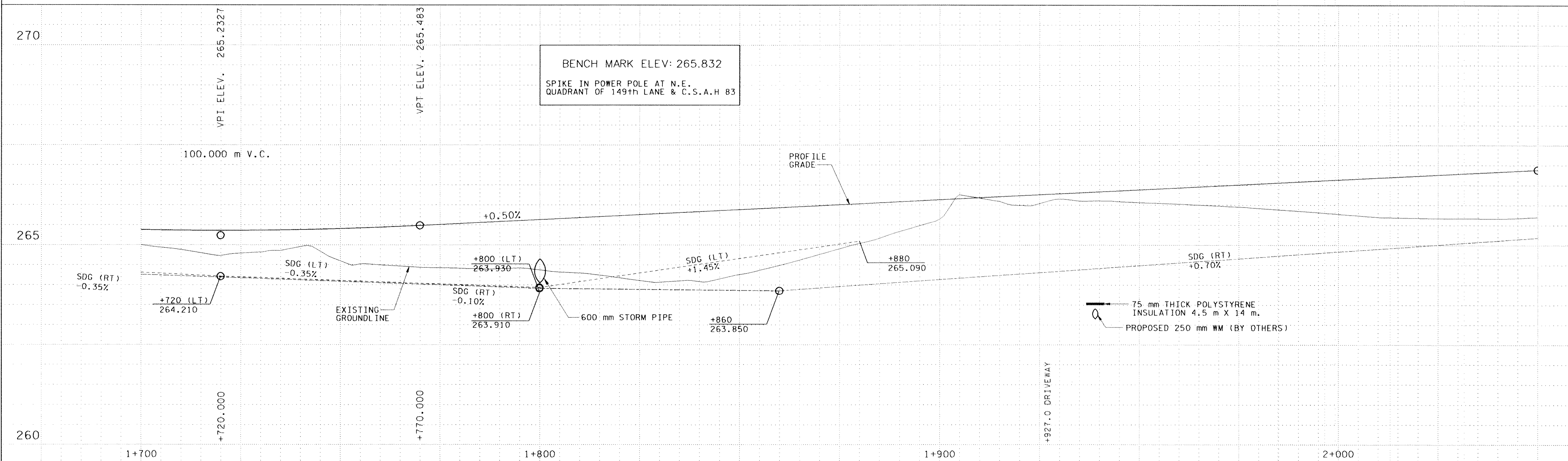
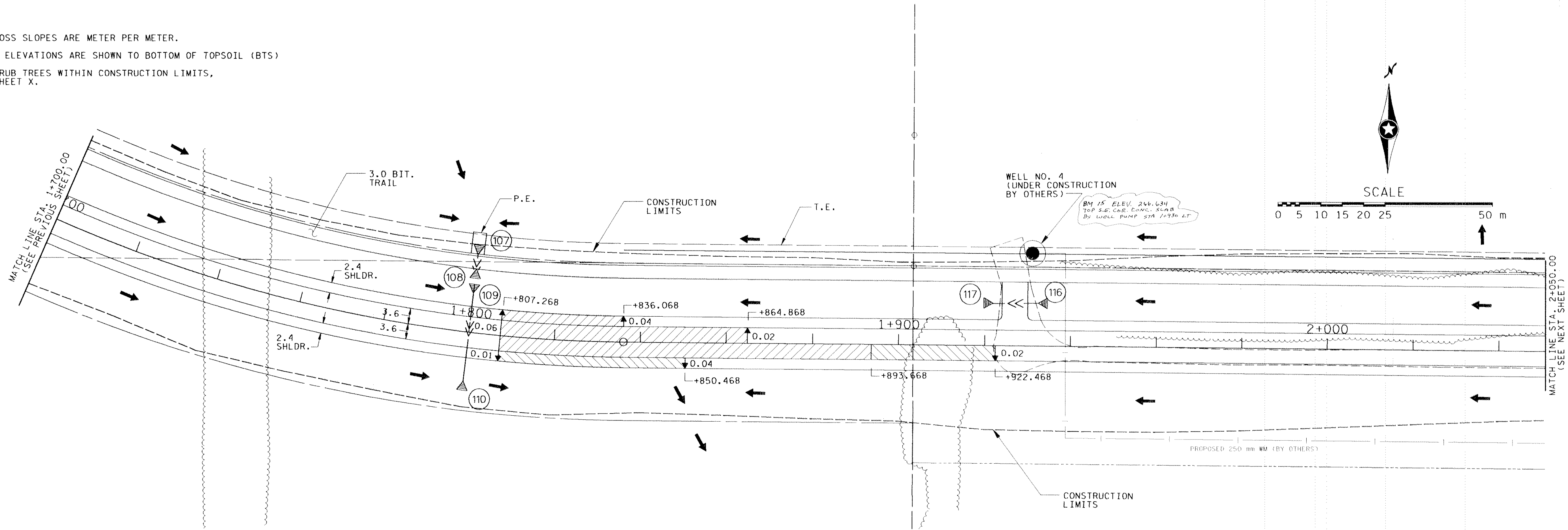

<table border="1"> <thead> <tr> <th>NO.</th> <th>DATE</th> <th>BY</th> <th>CHKD</th> <th>APPR</th> <th>REVISION</th> </tr> </thead> <tbody> <tr> <td> </td> <td> </td> <td> </td> <td> </td> <td> </td> <td> </td> </tr> </tbody> </table>					NO.	DATE	BY	CHKD	APPR	REVISION								I hereby certify that this plan, specification or report was prepared by me or under my direct supervision and that I am a duly Registered Professional Engineer under the laws of the State of Minnesota. <i>M. Hansen</i> Date: 6-25-98 Reg. No. 21364	COUNTY PROJ. NO. 95-05-116 CITY PROJECT NO. 97-25	DRAWN BY W. ANDERSON 3-98 DESIGNED BY B. URBANEK 3-98 CHECKED BY M. HANSEN 5-98 COMM. NO. 0982953		ANOKA COUNTY CONSTRUCTION PLAN & PROFILE C.R. 116 STA. 1+700 TO STA. 2+050		SHEET 17 OF 59
NO.	DATE	BY	CHKD	APPR	REVISION																			
NAME: 2953 CPC DATE: May, 20, 1998 TIME: 13:07:29					STA. 1+700 TO STA. 2+050																			

NOTES:
 PAVEMENT CROSS SLOPES ARE METER PER METER.
 DITCH GRADE ELEVATIONS ARE SHOWN TO BOTTOM OF TOPSOIL (BTS)
 CLEAR AND GRUB TREES WITHIN CONSTRUCTION LIMITS,
 SEE TAB X SHEET X.

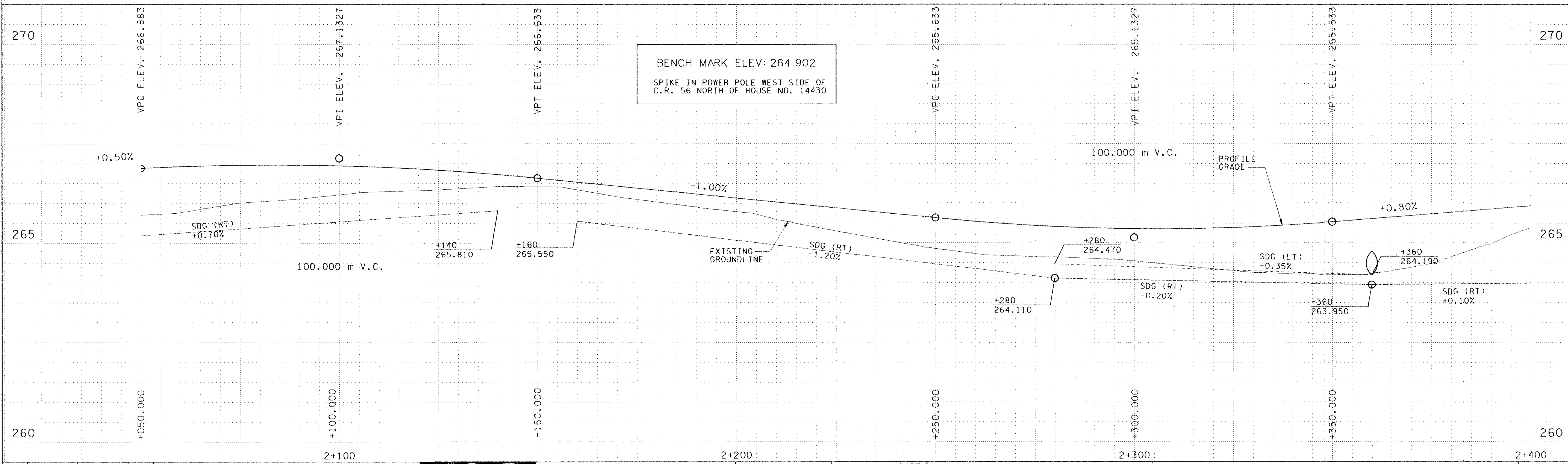
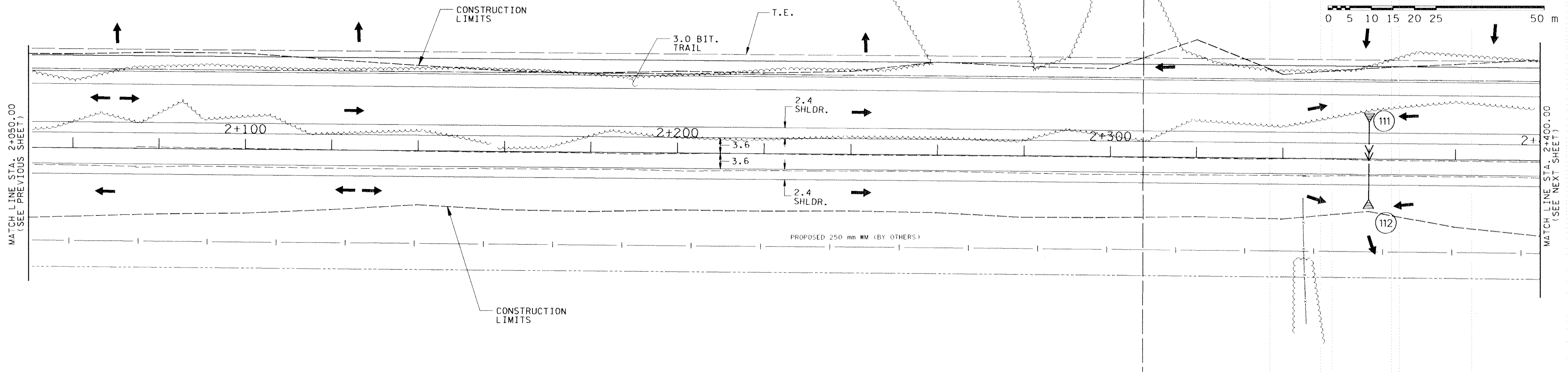
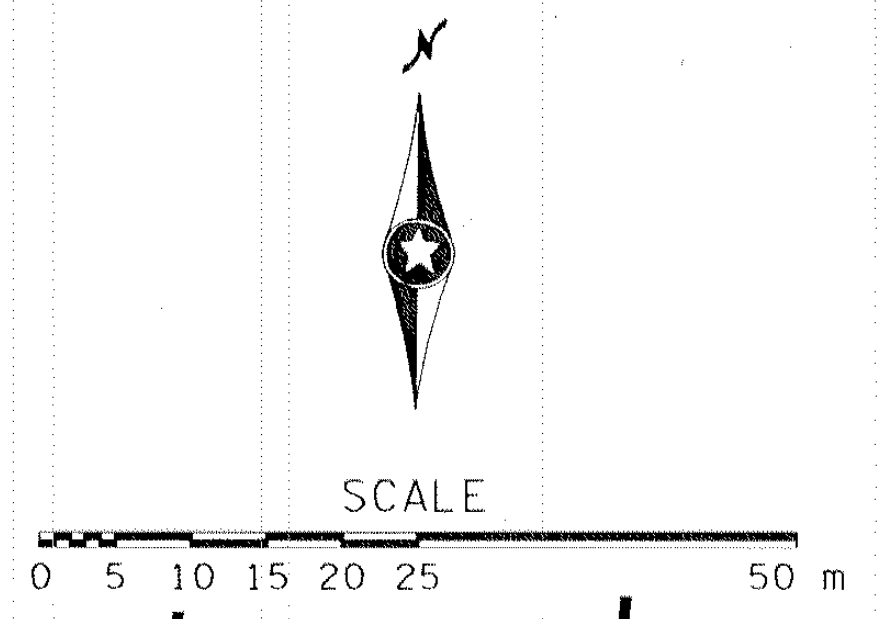

NO	DATE	BY	CHKD	APPR	REVISION

NAME: 2953.CPD DATE: May, 20, 1998 TIME: 13:28:29



I hereby certify that this plan, specification or report was prepared by me or under my direct supervision and that I am a duly Registered Professional Engineer under the laws of the State of Minnesota.
M. Hansen
 Date: 6-25-98 Reg. No. 21364

COUNTY PROJ. NO.
 95-05-116
 CITY PROJECT NO.
 97-25

DRAWN BY
 W. ANDERSON 3-98
 DESIGNED BY
 B. URBANEK 3-98
 CHECKED BY
 M. HANSEN 5-98
 COMM. NO.
 0982953



ANOKA COUNTY
 CONSTRUCTION PLAN & PROFILE
 C.R. 116
 STA. 2+050 TO STA. 2+400

SHEET
 18
 OF
 59

NOTES:
 PAVEMENT CROSS SLOPES ARE METER PER METER.
 DITCH GRADE ELEVATIONS ARE SHOWN TO BOTTOM OF TOPSOIL (BTS)
 CLEAR AND GRUB TREES WITHIN CONSTRUCTION LIMITS,
 SEE TAB X SHEET X.

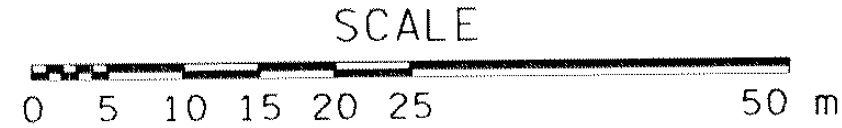

STREET RADII			
RADIUS	ALIGNMENT	STATION	LOCATION
15.0	CR 116	2+689.5	24.4 (LT)
15.0	CR 116	2+689.8	22.2 (RT)

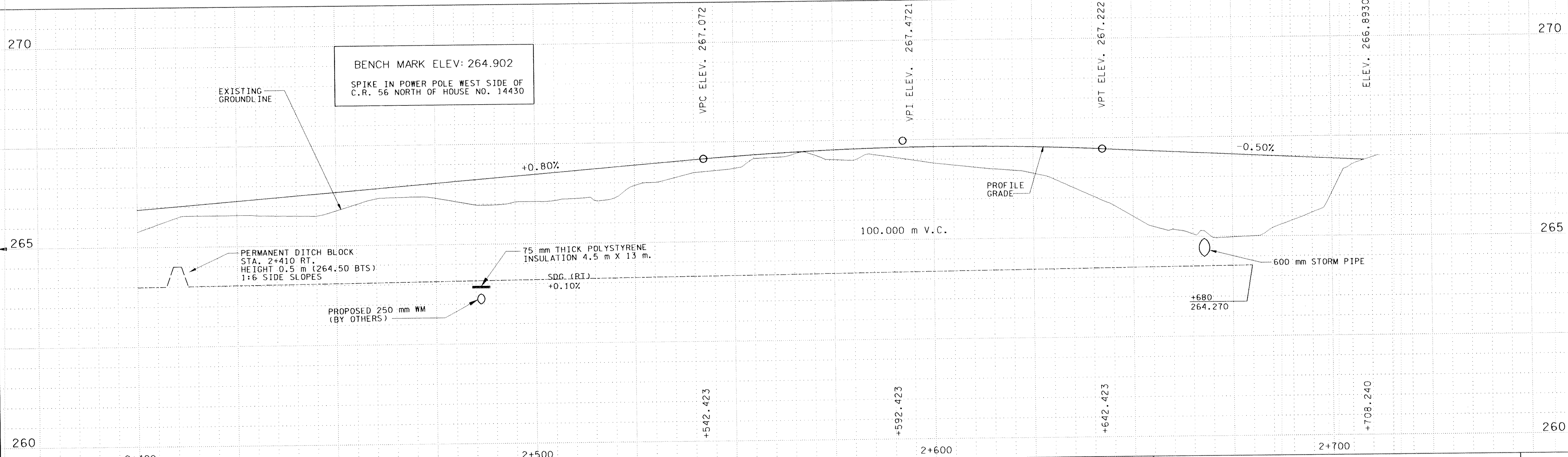
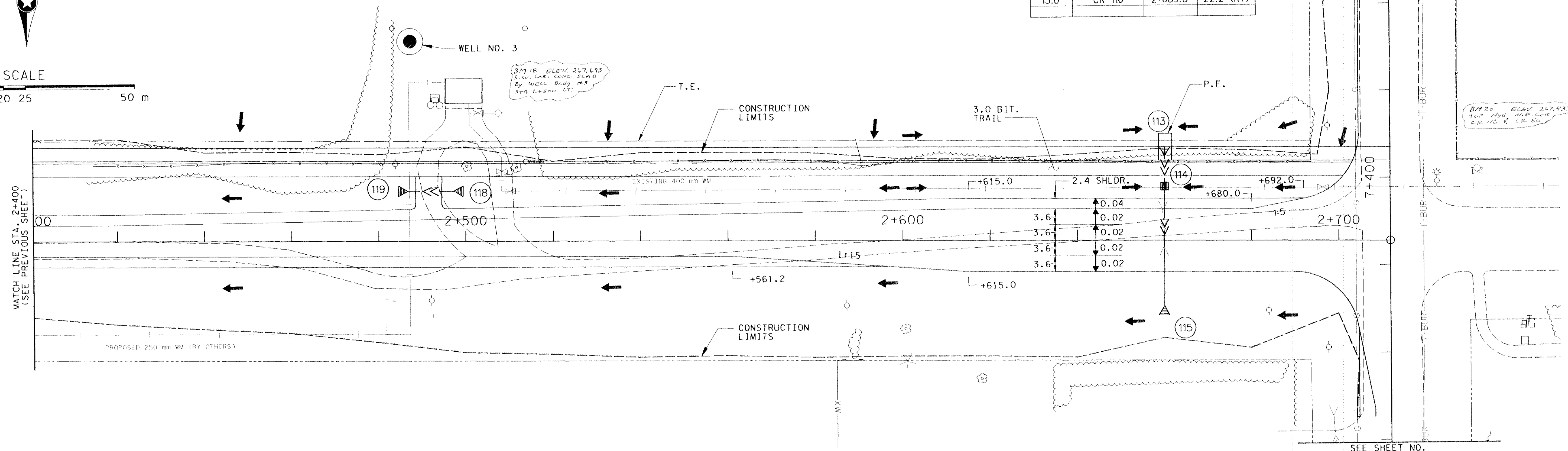

DESIGN FILE: R:\GIV\11047\2953\2953.dwg
 PLOT FILE: R:\GIV\11047\2953\2953.dwg
 PLOTTER: MS-DOS/Plotter-Memo-FR-WNDOT
 PLOT SCALE: 1:270000
 PLOT DATE/TIME: 06/23/98 13:26:25

NO	DATE	BY	CKD	APPR	REVISION

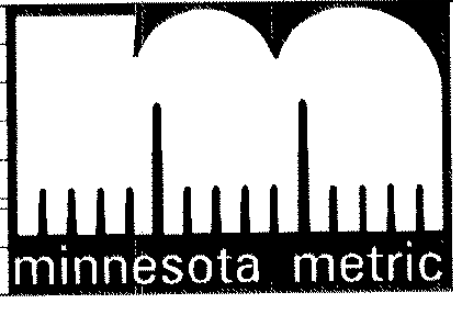

I hereby certify that this plan, specification or report was prepared by me or under my direct supervision and that I am a duly Registered Professional Engineer under the laws of the State of Minnesota.
M. Hansen
 Date: 6-25-98 Reg. No. 21364

COUNTY PROJ. NO.
 95-05-116
 CITY PROJECT NO.
 97-25

DRAWN BY
 W. ANDERSON 3-98
 DESIGNED BY
 B. URBANEK 3-98
 CHECKED BY
 M. HANSEN 5-98
 COMM. NO.
 0982953

ANOKA COUNTY
 CONSTRUCTION PLAN & PROFILE
 C.R. 116
 STA. 2+400 TO STA. 2+712

SHEET
 19
 OF
 59

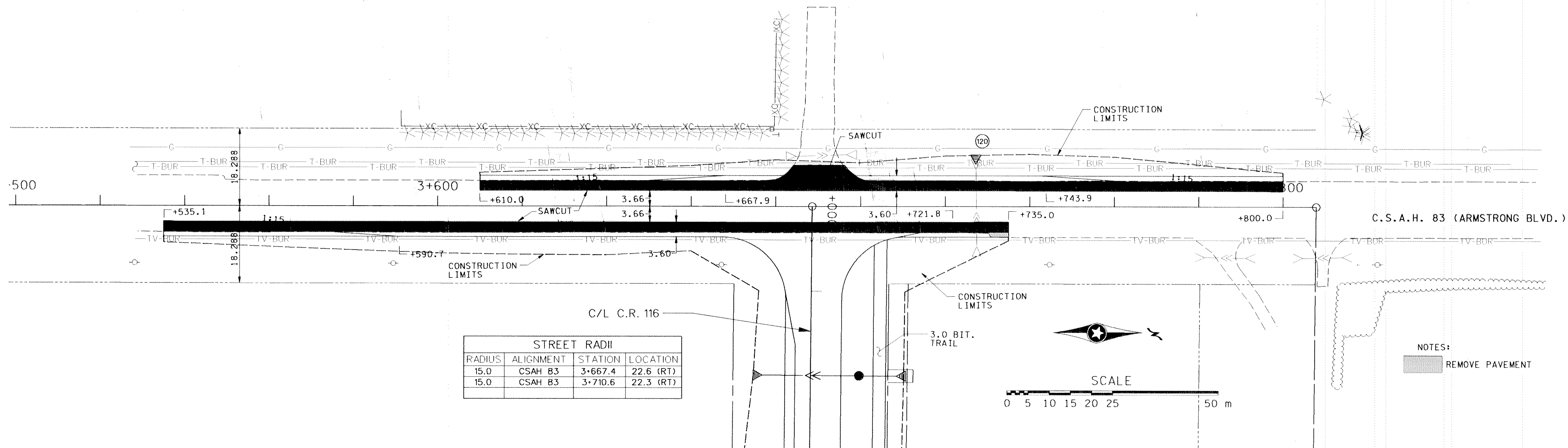

STREET RADII			
RADIUS	ALIGNMENT	STATION	LOCATION
15.0	CSAH 83	3+667.4	22.6 (RT)
15.0	CSAH 83	3+710.6	22.3 (RT)

NOTES:
 REMOVE PAVEMENT

C.S.A.H. 83 (ARMSTRONG BLVD.)

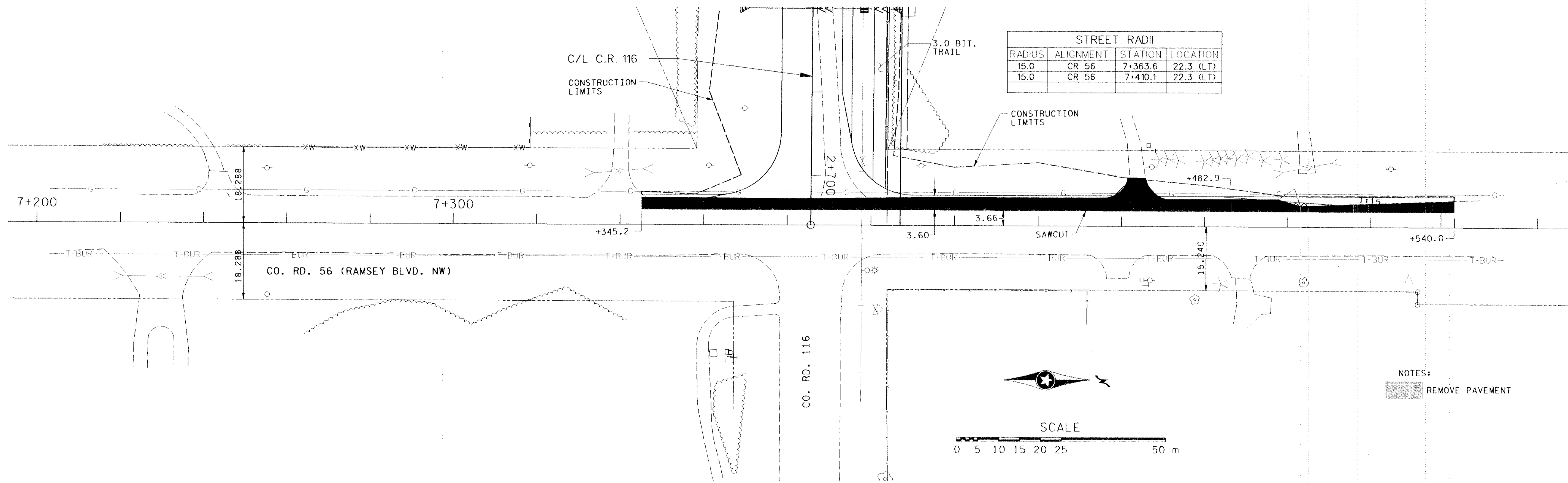

STREET RADII			
RADIUS	ALIGNMENT	STATION	LOCATION
15.0	CR 56	7+363.6	22.3 (LT)
15.0	CR 56	7+410.1	22.3 (LT)

NOTES:
 REMOVE PAVEMENT

CO. RD. 56 (RAMSEY BLVD. NW)

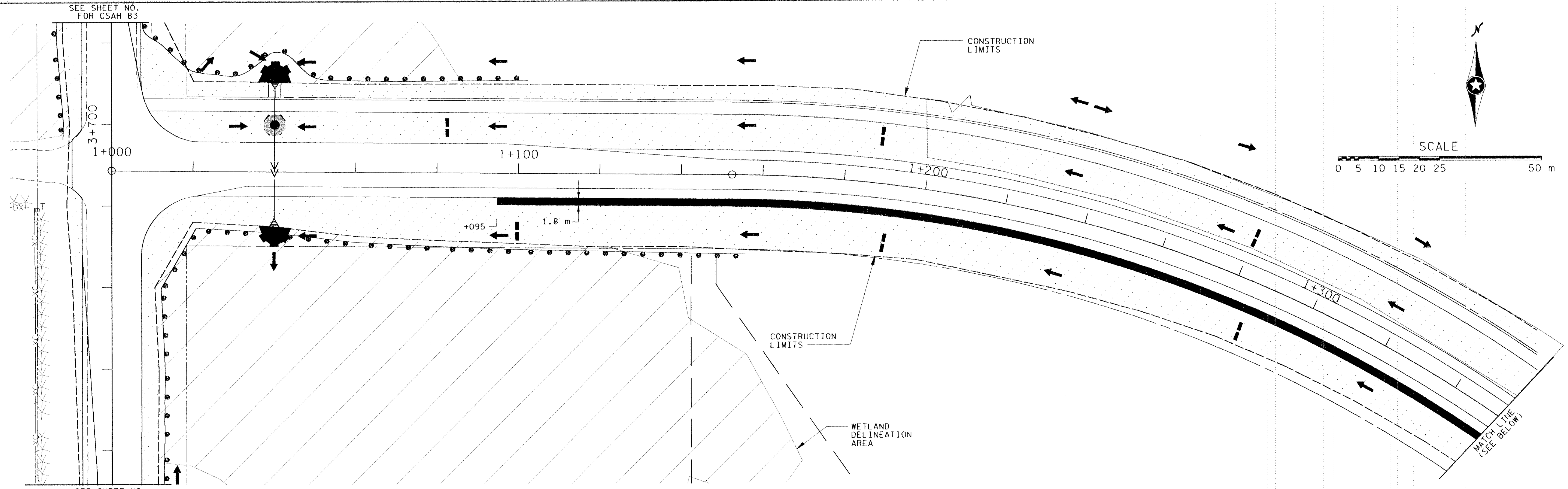

SEE SHEET NO. FOR CSAH 83

SEE SHEET NO. FOR CSAH 83

LEGEND

- SILT FENCE
- BALE DITCH SEDIMENT CHECK
- SEED (MIXTURE 70A)
- SEED (MIXTURE 70A) W/ STRAW IS BLANKET
- DIRECTION OF FLOW

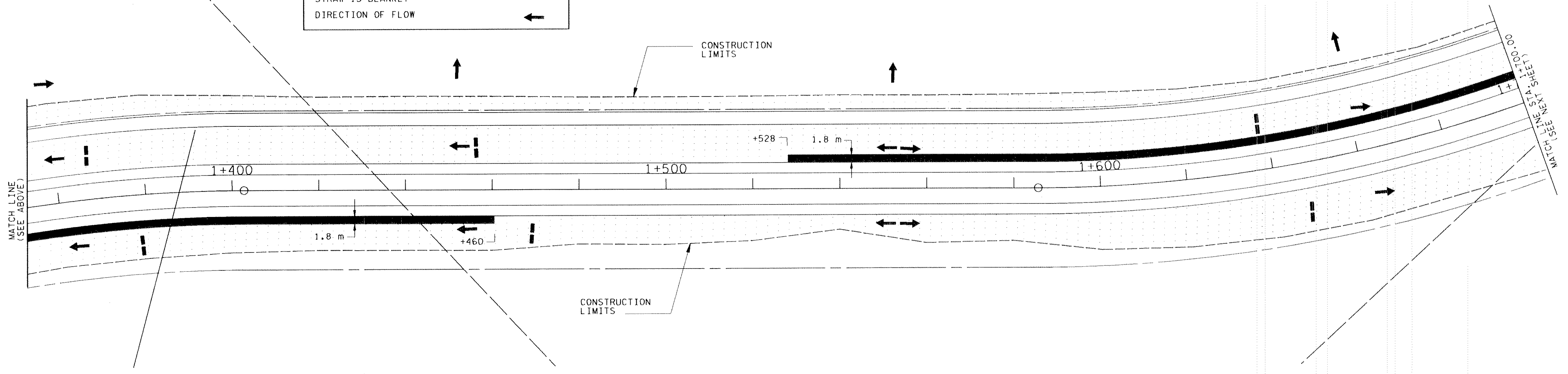
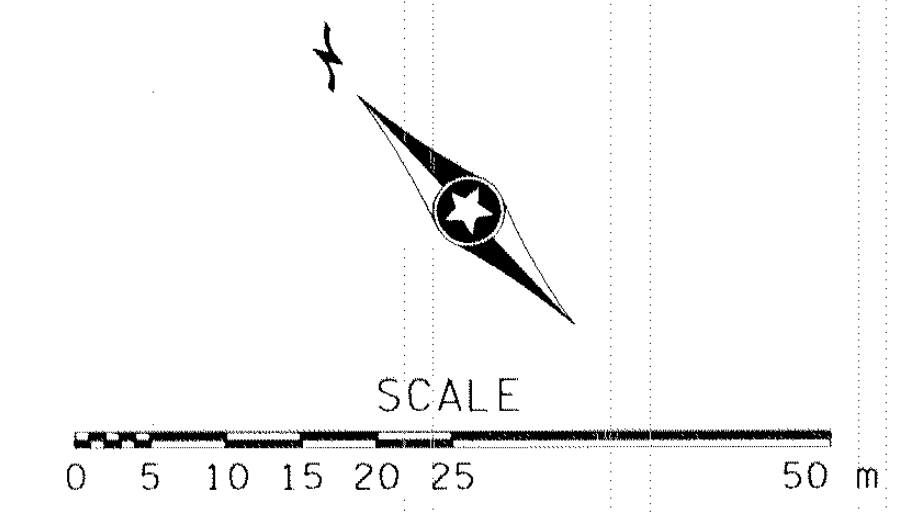

NO.	DATE	BY	CHKD	APPR	REVISION

NAME: 2953.TEA DATE: May 20, 1998 TIME: 16:23:34



I hereby certify that this plan, specification or report was prepared by me or under my direct supervision and that I am a duly Registered Professional Engineer under the laws of the State of Minnesota.

M. Hansen
Date: 6-25-98 Reg. No. 21364

COUNTY PROJ. NO.
95-05-116

CITY PROJECT NO.
97-25

DRAWN BY
W. ANDERSON

DESIGNED BY
B. URBANEK

CHECKED BY
M. HANSEN

DATE
3-98

DATE
3-98

DATE
5-98

COMM. NO.
0982953



ANOKA COUNTY

TURF ESTABLISHMENT & EROSION CONTROL PLAN

C.R. 116

STA. 1+000 TO STA. 1+700

SHEET
22
OF
59

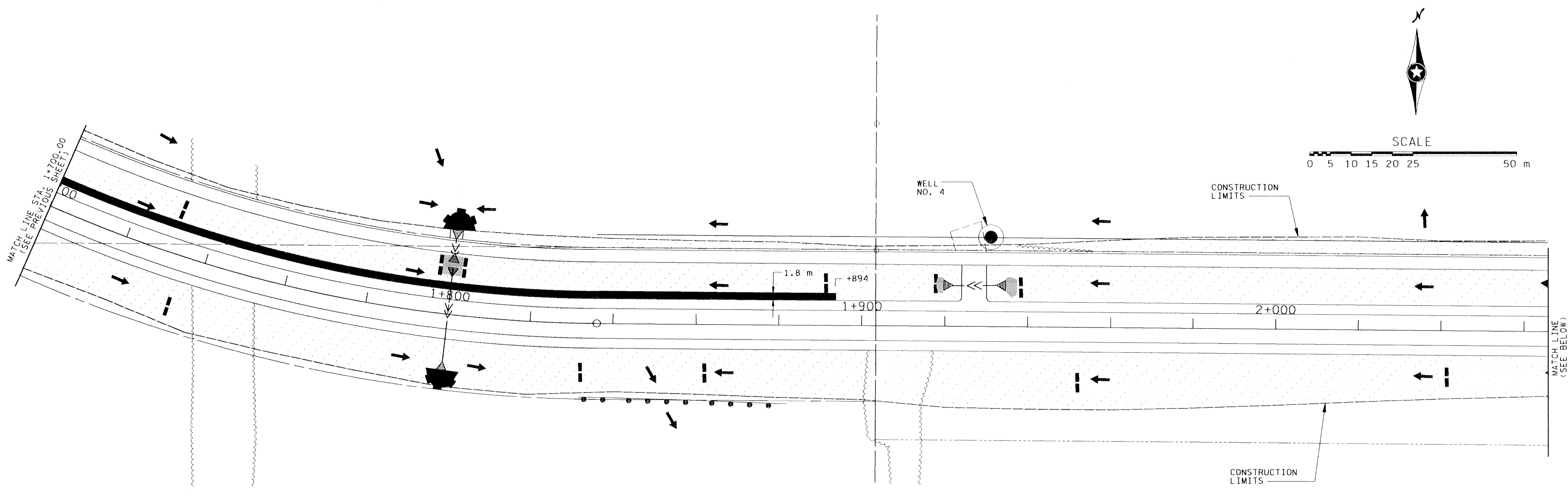

LEGEND

SILT FENCE	
BALE DITCH SEDIMENT CHECK	
SEED (MIXTURE 70A)	
SEED (MIXTURE 70A) W/ STRAW IS BLANKET	
DIRECTION OF FLOW	

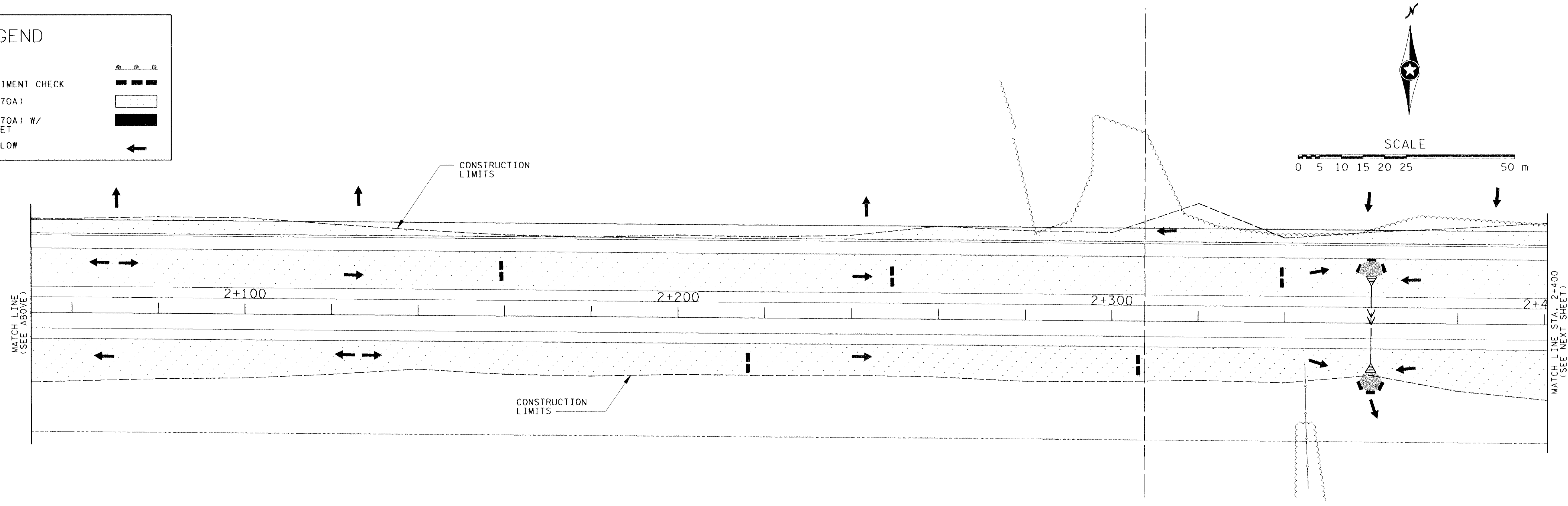

DESIGN FILE: R:\CIVIL\0472953\2953.dwg
 PRF FILE: R:\CIVIL\0472953\2953.dwg
 PLOT FILE: R:\CIVIL\0472953\2953.dwg
 PLOT DATE: 06/29/98 13:40:05

NO	DATE	BY	CHKD	APPR	REVISION

NAME: 2953.TEB DATE: May. 20, 1998 TIME: 16:24:42



I hereby certify that this plan, specification or report was prepared by me or under my direct supervision and that I am a duly Registered Professional Engineer under the laws of the State of Minnesota.

Wesley D. Hain
 Date: 6-25-98 Reg. No. 21364

COUNTY PROJ. NO.
95-05-116

CITY PROJECT NO.
97-25

DRAWN BY
W. ANDERSON 3-98

DESIGNED BY
B. URBANEK 3-98

CHECKED BY
M. HANSEN 5-98

COMM. NO.
0982953



ANOKA COUNTY

TURF ESTABLISHMENT & EROSION CONTROL PLAN

C.R. 116

STA. 1+700 TO STA. 2+400



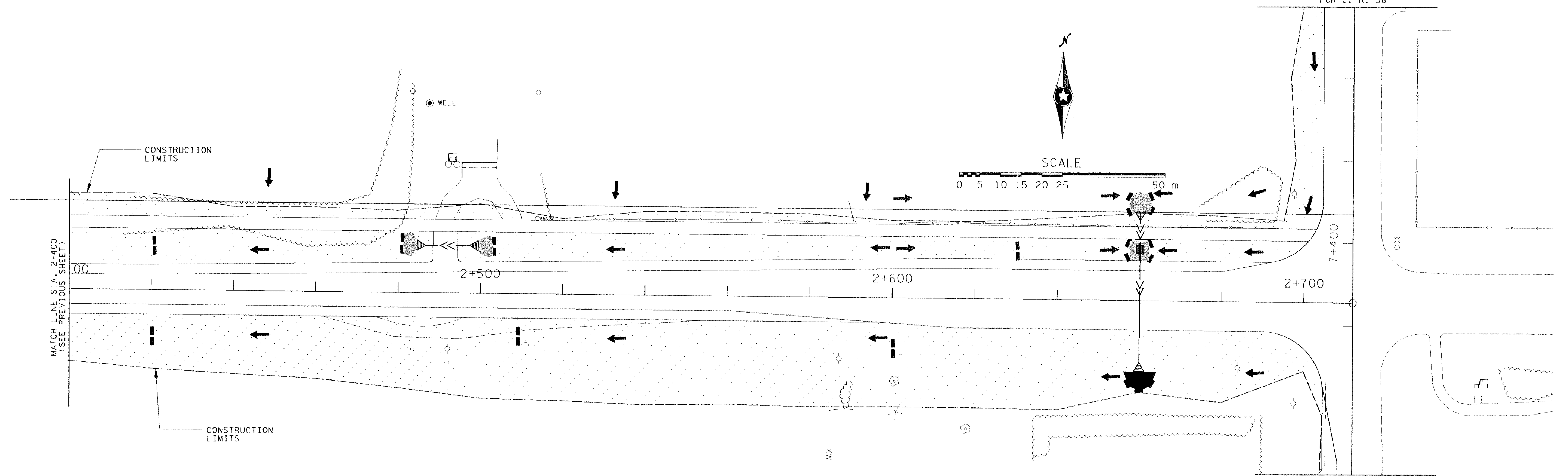

SHEET
23
OF
59

SEE SHEET NO.
FOR C. R. 56

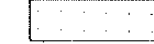

SEE SHEET NO.
FOR C. R. 56

LEGEND

- SILT FENCE 
- BALE DITCH SEDIMENT CHECK 
- SEED (MIXTURE 70A) 
- SEED (MIXTURE 70A) W/
STRAW IS BLANKET 
- DIRECTION OF FLOW 

NO	DATE	BY	CKD	APPR	REVISION

NAME: 2953.TEC DATE: May, 20, 1998 TIME: 07:05:57

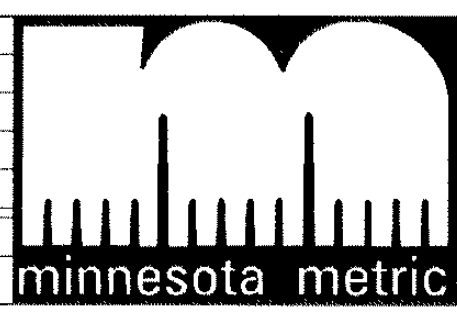

I hereby certify that this plan, specification or report was prepared by me or under my direct supervision and that I am a duly Registered Professional Engineer under the laws of the State of Minnesota.

W. Anderson
Date 6-25-98 Reg. No. 21364

COUNTY PROJ. NO.
95-05-116

CITY PROJECT NO.
97-25

DRAWN BY
W. ANDERSON DATE
3-98

DESIGNED BY
B. URBANEK 3-98

CHECKED BY
M. HANSEN 5-98

COMM. NO.
0982953



ANOKA COUNTY





TURF ESTABLISHMENT & EROSION CONTROL PLAN

C.R. 116

STA. 2+400 TO STA. 2+712

SHEET
24
OF
59

LEGEND

- SILT FENCE 
- BALE DITCH SEDIMENT CHECK 
- SEED (MIXTURE 70A) 
- SEED (MIXTURE 70A) W/
STRAW IS BLANKET 
- DIRECTION OF FLOW 

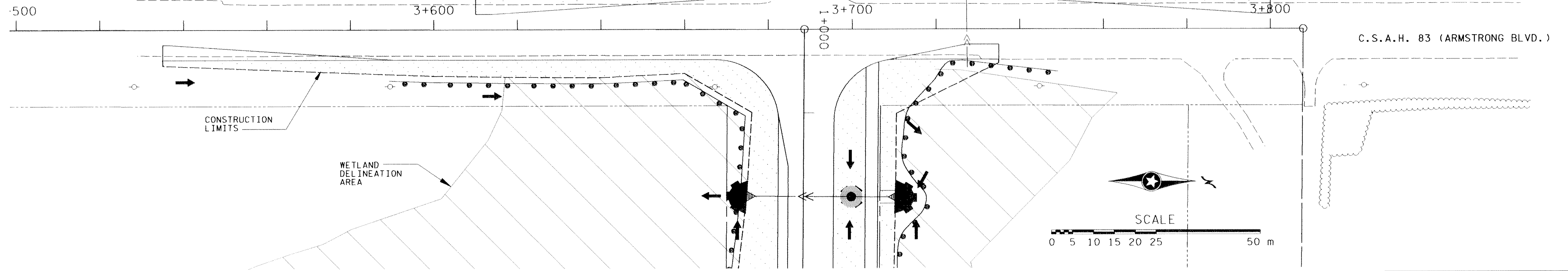

C.S.A.H. 83 (ARMSTRONG BLVD.)

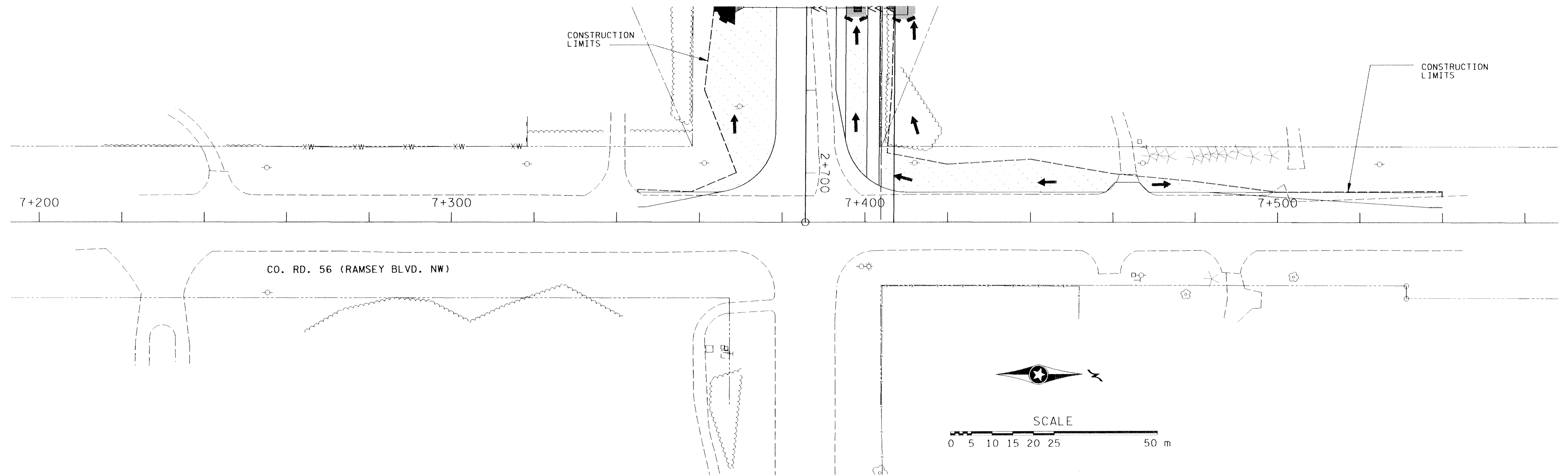

CO. RD. 56 (RAMSEY BLVD. NW)

NO.	DATE	BY	CHKD	APPR	REVISION
NAME: 2953.TED DATE: May 20, 1998 TIME: 16:25:55					



I hereby certify that this plan, specification or report was prepared by me or under my direct supervision and that I am a duly Registered Professional Engineer under the laws of the State of Minnesota.

M. Hansen
Date 6-25-98 Reg. No. 21364

COUNTY PROJ. NO.
95-05-116

CITY PROJECT NO.
97-25

DRAWN BY
W. ANDERSON DATE
3-98

DESIGNED BY
B. URBANEK 3-98

CHECKED BY
M. HANSEN 5-98

COMM. NO.
0982953



ANOKA COUNTY

TURF ESTABLISHMENT & EROSION CONTROL PLAN

C.R. 116

SHEET
25
OF
59

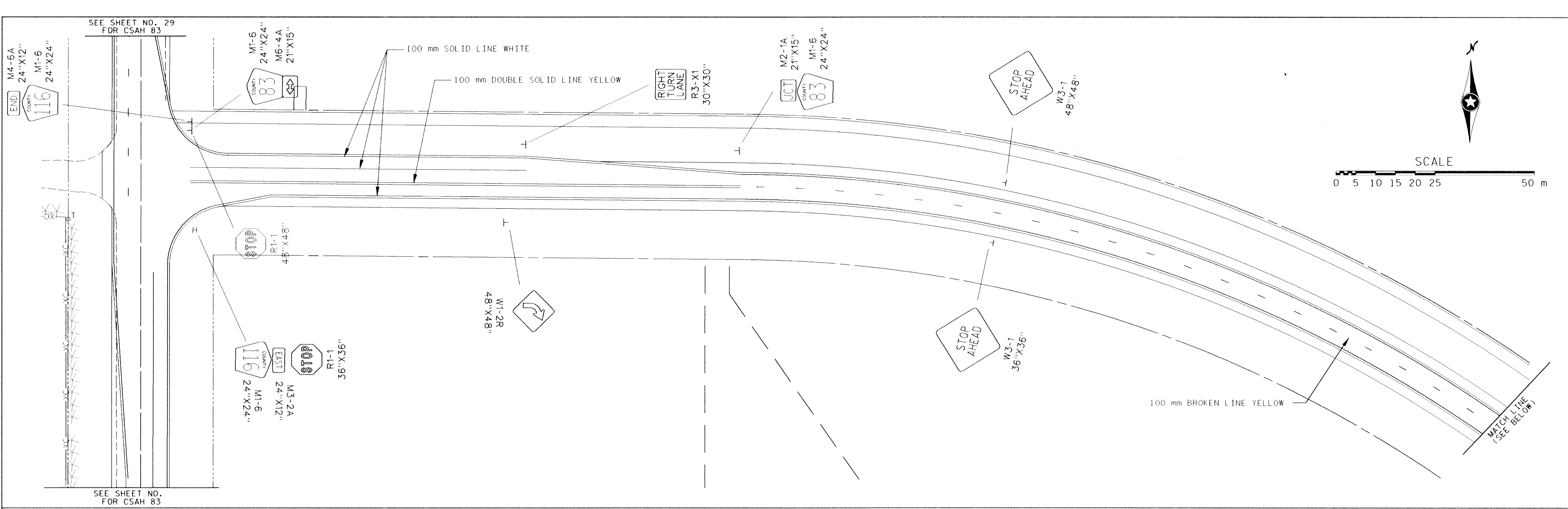

NOTES:

- ALL STRIPING DIMENSIONS ARE IN MILLIMETERS UNLESS NOTED OTHERWISE.
- ALL STRIPING SHALL BE LATEX UNLESS NOTED OTHERWISE.
- BROKEN LINE SKIP RATIO SHALL BE 2 m STRIPE FOLLOWED BY 8 m GAP.
- PROPOSED SIGN DIMENSIONS ARE GIVEN IN ENGLISH UNITS OF INCHES. (SQ. FT. X 0.092903 = m²)
- LOCATION OF NO PASSING ZONE, SIGNS AND STRIPING SHOWN ON THE PLANS IS APPROXIMATE AND MAY BE MODIFIED IN THE FIELD BY THE ENGINEER.
- ADVISORY SPEED WILL BE DETERMINED IN THE FIELD. IF ADVISORY SPEED SIGN PANELS ARE NECESSARY, THEY WILL BE SUPPLIED BY THE ENGINEER.

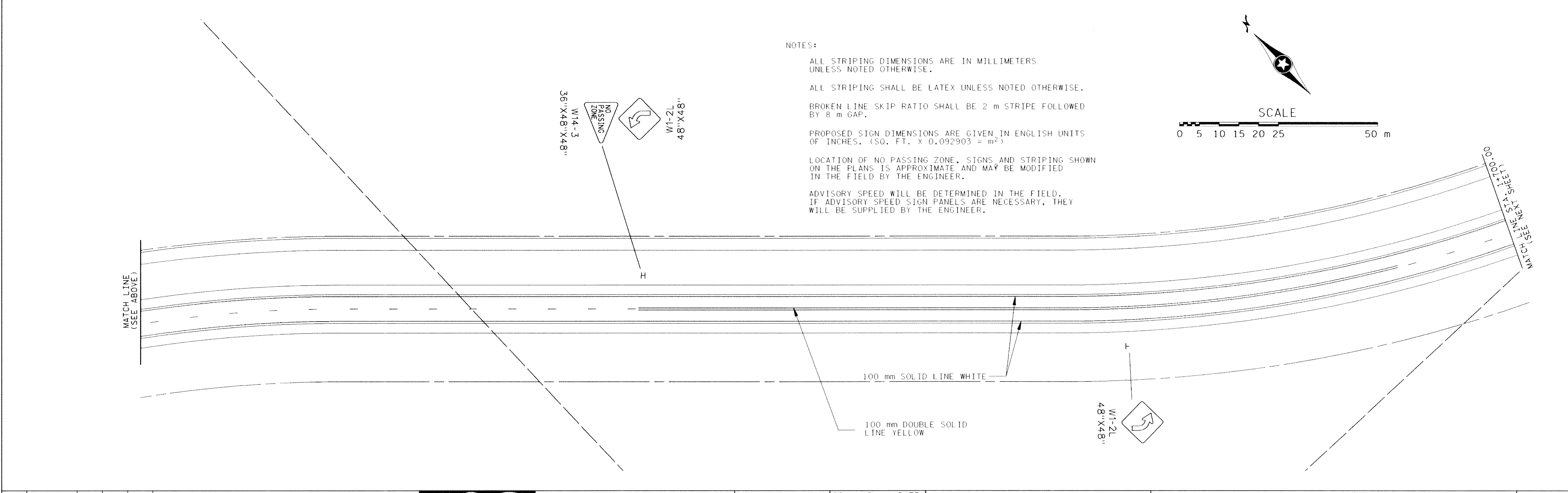
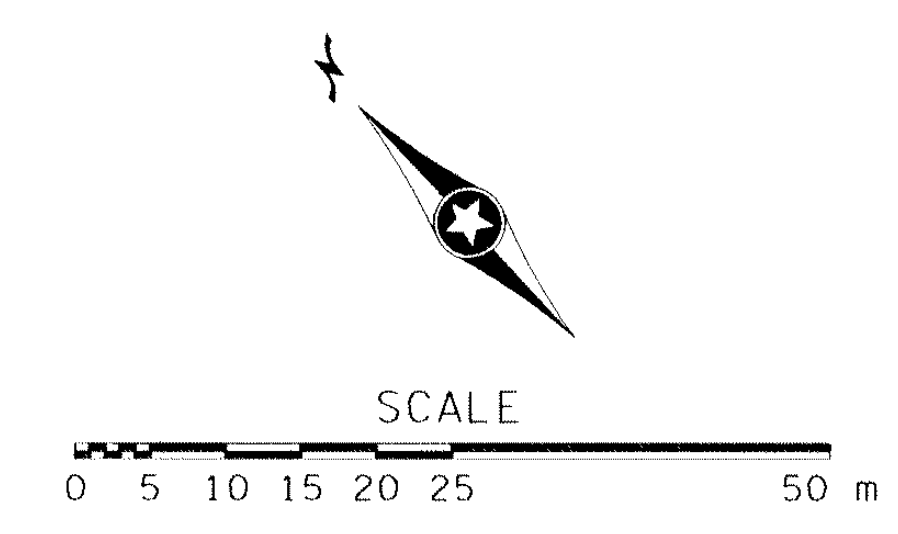

1	6-29-98	JEH	JRD	REVISE STOP SIGN	
NO	DATE	BY	CHK	APPR	REVISION
NAME: 2953 SSA DATE: May 20, 1998 TIME: 16:55:18					

I hereby certify that this plan, specification or report was prepared by me or under my direct supervision and that I am a duly Registered Professional Engineer under the laws of the State of Minnesota.

Matthew D. Han
Date: 6-25-98 Reg. No. 21364

COUNTY PROJ. NO.
95-05-116

CITY PROJECT NO.
97-25

DRAWN BY
W. ANDERSON

DESIGNED BY
B. URBANEK

CHECKED BY
M. HANSEN

DATE
3-98

COMM. NO.
0982953

ANOKA COUNTY

SIGNING & STRIPING PLAN

C.R. 116

STA. 1+000 TO STA. 1+700

SHEET
26
OF
59

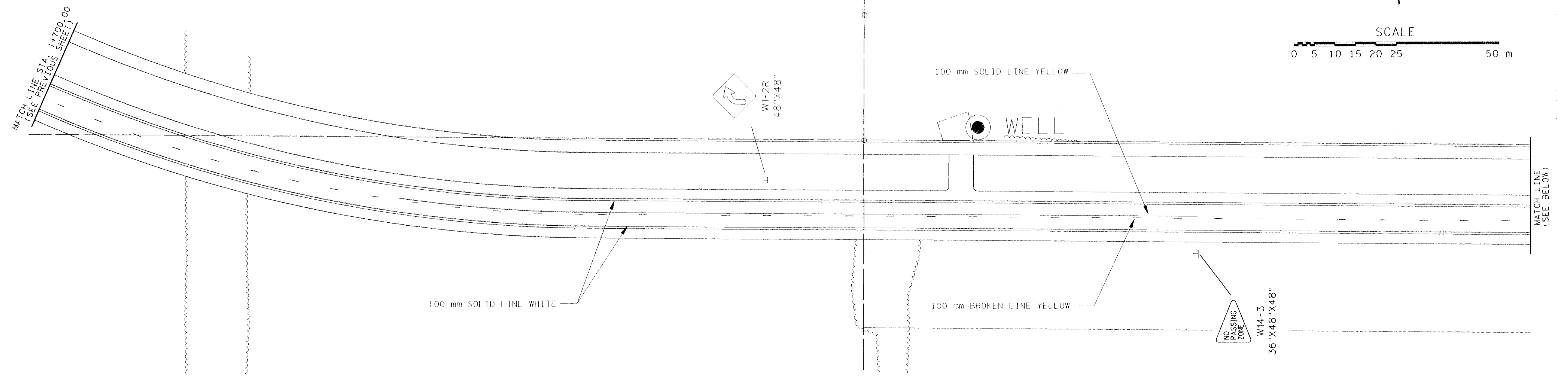
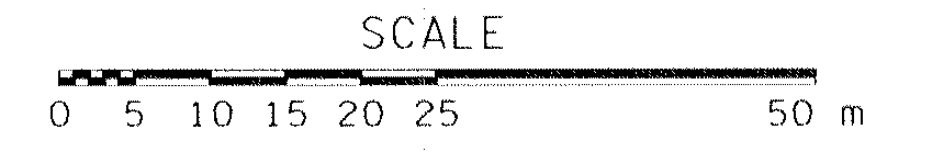

NOTES:

- ALL STRIPING DIMENSIONS ARE IN MILLIMETERS UNLESS NOTED OTHERWISE.
- ALL STRIPING SHALL BE LATEX UNLESS NOTED OTHERWISE.
- BROKEN LINE SKIP RATIO SHALL BE 2 m STRIPE FOLLOWED BY 8 m GAP.
- PROPOSED SIGN DIMENSIONS ARE GIVEN IN ENGLISH UNITS OF INCHES. (SQ. FT. X 0.092903 = m²)
- LOCATION OF NO PASSING ZONE, SIGNS AND STRIPING SHOWN ON THE PLANS IS APPROXIMATE AND MAY BE MODIFIED IN THE FIELD BY THE ENGINEER.
- ADVISORY SPEED WILL BE DETERMINED IN THE FIELD. IF ADVISORY SPEED SIGN PANELS ARE NECESSARY, THEY WILL BE SUPPLIED BY THE ENGINEER.

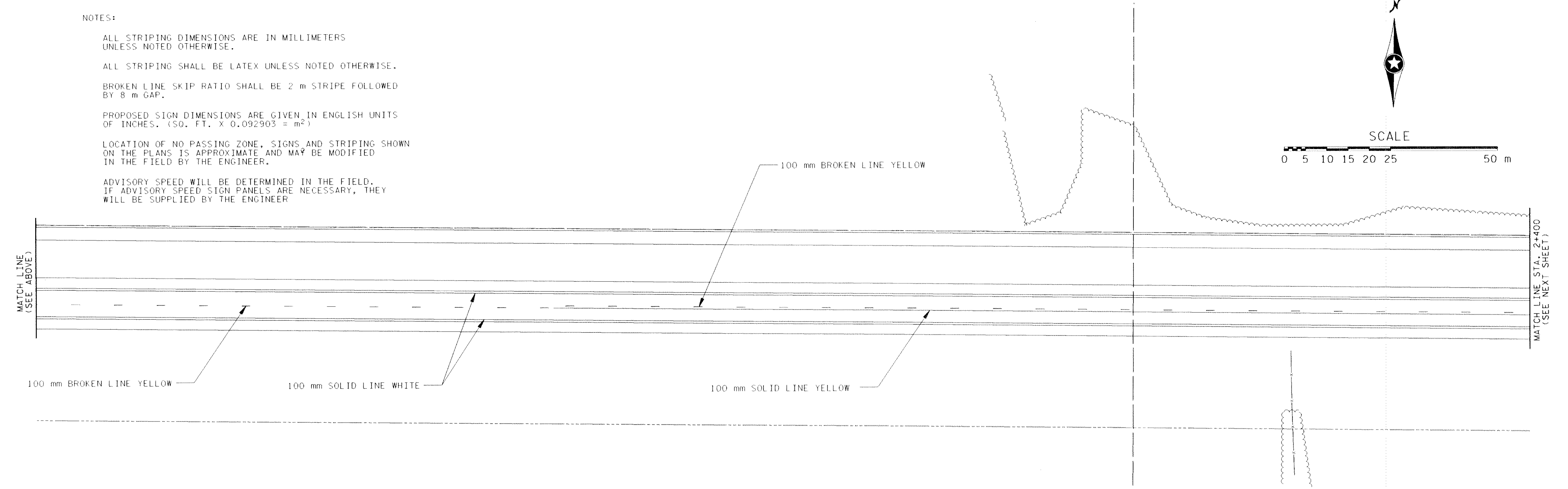
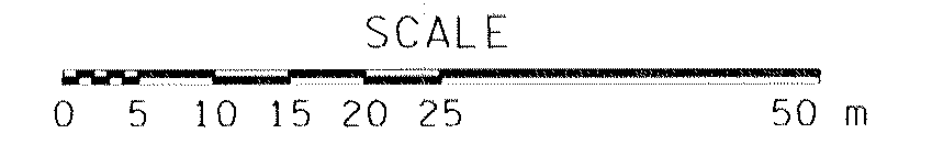

DESIGN FILE: P:\15\11\047\2953\2953.dwg
 PLOT FILE: P:\15\11\047\2953\2953.plt
 PLOTTED: MS-DOS/HP-GL/Postscript/None/FR-WOOD
 PLOT SCALE: 12:100000
 PLOT DATE/TIME: 06/29/98 13:43:00

NO	DATE	BY	CHKD	APPR	REVISION

NAME: 2953.SSB DATE: May 20, 1998 TIME: 16:58:27



I hereby certify that this plan, specification or report was prepared by me or under my direct supervision and that I am a duly Registered Professional Engineer under the laws of the State of Minnesota.

M. Hansen
 Date: 6-25-98 Reg. No. 21364

COUNTY PROJ. NO.
95-05-116

CITY PROJECT NO.
97-25

DRAWN BY: W. ANDERSON DATE: 3-98
 DESIGNED BY: B. URBANEK DATE: 3-98
 CHECKED BY: M. HANSEN DATE: 5-98
 COMM. NO.: 0982953



ANOKA COUNTY
 SIGNING & STRIPING PLAN
 C.R. 116
 STA. 1+700 TO STA. 2+400

SHEET
 27
 OF
 59

NOTES:

ALL STRIPING DIMENSIONS ARE IN MILLIMETERS UNLESS NOTED OTHERWISE.

ALL STRIPING SHALL BE LATEX UNLESS NOTED OTHERWISE.

BROKEN LINE SKIP RATIO SHALL BE 2 m STRIPE FOLLOWED BY 8 m GAP.

PROPOSED SIGN DIMENSIONS ARE GIVEN IN ENGLISH UNITS OF INCHES. (SQ. FT. X 0.092903 = m²)

LOCATION OF NO PASSING ZONE, SIGNS AND STRIPING SHOWN ON THE PLANS IS APPROXIMATE AND MAY BE MODIFIED IN THE FIELD BY THE ENGINEER.

ADVISORY SPEED WILL BE DETERMINED IN THE FIELD. IF ADVISORY SPEED SIGN PANELS ARE NECESSARY, THEY WILL BE SUPPLIED BY THE ENGINEER.

SEE SHEET NO. 29 FOR SIGNING AND STRIPING ON C.R. 56

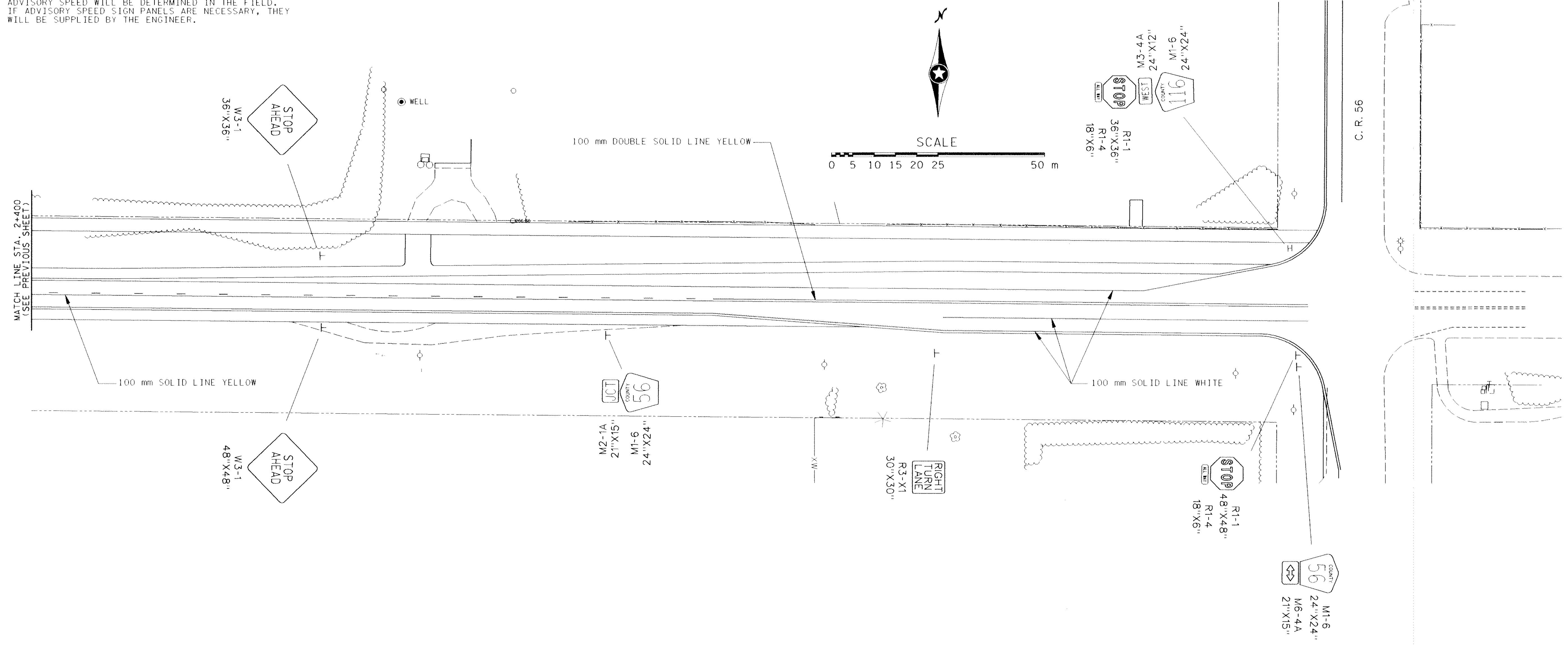

1	6-29-98	JEH	JRD	REVISE STOP SIGN
NO	DATE	BY	CKD	APPR
NAME: 2953 SSC	DATE: May 20, 1998	TIME: 16:59:48		

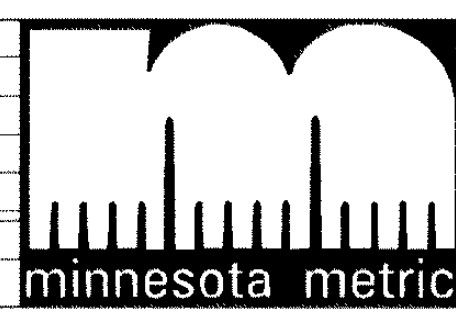

I hereby certify that this plan, specification or report was prepared by me or under my direct supervision and that I am a duly Registered Professional Engineer under the laws of the State of Minnesota.

Michael D. Han
Date 6-25-98 Reg. No. 21364

COUNTY PROJ. NO.
95-05-116

CITY PROJECT NO.
97-25

DRAWN BY
W. ANDERSON DATE
3-98

DESIGNED BY
B. URBANEK 3-98

CHECKED BY
M. HANSEN 5-98

COMM. NO.
0982953



ANOKA COUNTY
SIGNING & STRIPING PLAN
C.R. 116
STA. 2+400 TO STA. 2+712

SHEET
28
OF
59

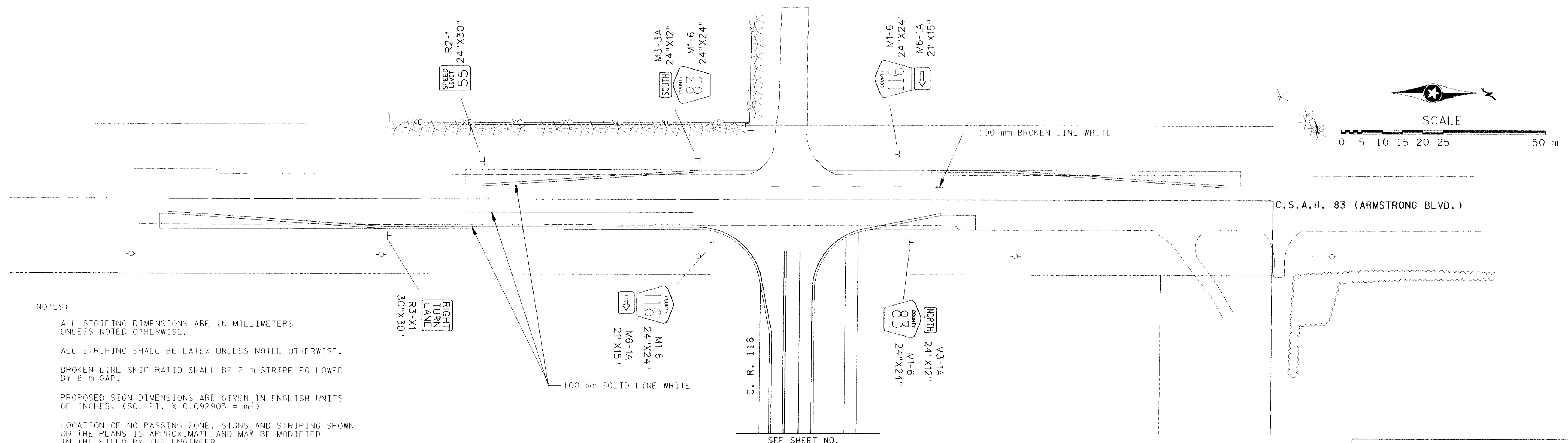
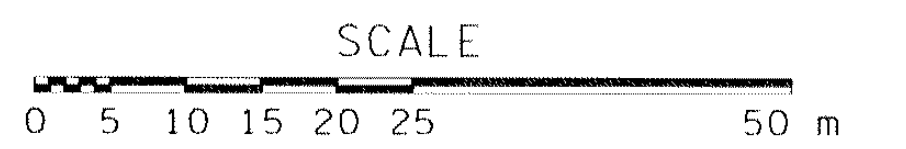
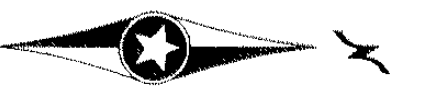

NOTES:

ALL STRIPING DIMENSIONS ARE IN MILLIMETERS UNLESS NOTED OTHERWISE.

ALL STRIPING SHALL BE LATEX UNLESS NOTED OTHERWISE.

BROKEN LINE SKIP RATIO SHALL BE 2 m STRIPE FOLLOWED BY 8 m GAP.

PROPOSED SIGN DIMENSIONS ARE GIVEN IN ENGLISH UNITS OF INCHES. (50. FT. X 0.092903 = m²)

LOCATION OF NO PASSING ZONE, SIGNS AND STRIPING SHOWN ON THE PLANS IS APPROXIMATE AND MAY BE MODIFIED IN THE FIELD BY THE ENGINEER.

ADVISORY SPEED WILL BE DETERMINED IN THE FIELD. IF ADVISORY SPEED SIGN PANELS ARE NECESSARY, THEY WILL BE SUPPLIED BY THE ENGINEER.

- ① SALVAGE INPLACE SIGN PANEL. DELIVER TO ANOKA COUNTY HIGHWAY DEPARTMENT.
- ② SALVAGE AND INSTALL INPLACE SIGN PANEL.

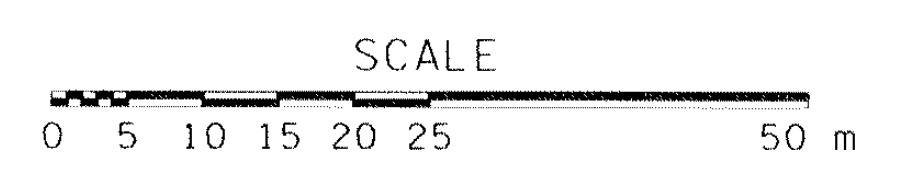
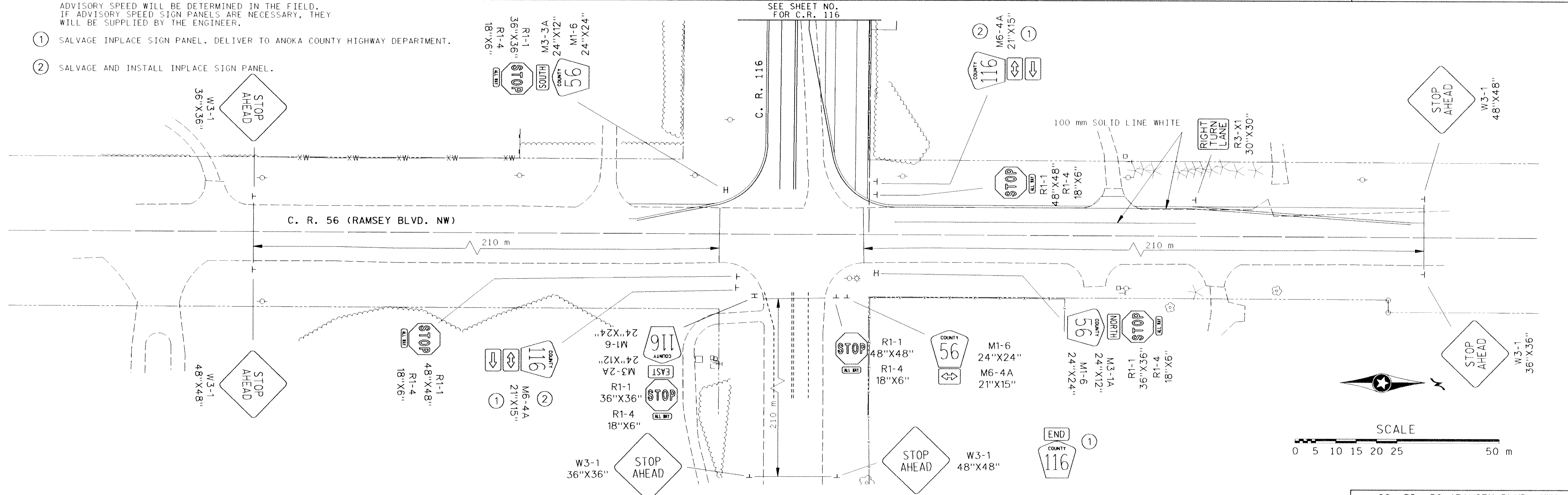

NO.	DATE	BY	CHKD	APPR	REVISION
1	6-29-98	JEH	JRD		REVISE STOP SIGN

NAME: 2953.SSD	DATE: May. 15, 1998	TIME: 06:23:46
----------------	---------------------	----------------

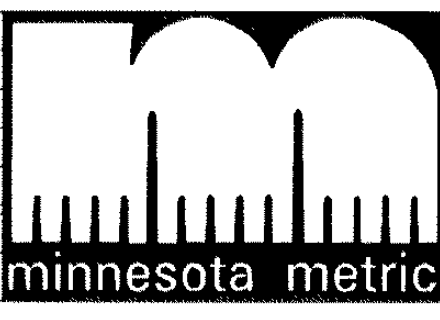

I hereby certify that this plan, specification or report was prepared by me or under my direct supervision and that I am a duly Registered Professional Engineer under the laws of the State of Minnesota.

Maahn D. Hansen
Date: 6-25-98 Reg. No. 21364

COUNTY PROJ. NO.
95-05-116

CITY PROJECT NO.
97-25

DRAWN BY
W. ANDERSON

DESIGNED BY
B. URBANEK

CHECKED BY
M. HANSEN

DATE
3-98

COMM. NO.
0982953



ANOKA COUNTY
SIGNING & STRIPING PLAN
C.R. 116
C.S.A.H. 83 & CO. RD. 56



SHEET
29
OF
59

DESIGN FILE: P:\CIVIL\0472953\2953.ssd
 PLOT FILE: P:\CIVIL\0472953\2953.plt
 PLOTTER: MS-DesignJet-Mono-FR-MD0T
 PLOT SCALE: 1:2.00000
 PLOT DATE/TIME: 06/29/98 15:28:03

NOTES:

- ① CONTRACTOR SHALL CONDUCT OPERATIONS TO MINIMIZE DISTURBANCE TO ADJACENT WETLANDS.
- ② PROPOSED CONTOURS SHOWN REPRESENT FINISHED SURFACE.
- ③ MITIGATION AREA SHALL BE OVER EXCAVATED BY A 0.3 m DEPTH AND BACKFILLED TO FINISHED SURFACE WITH MUCK DISPOSAL MATERIAL.

LEGEND

- SILT FENCE 
- SEED (MIXTURE 25A) 

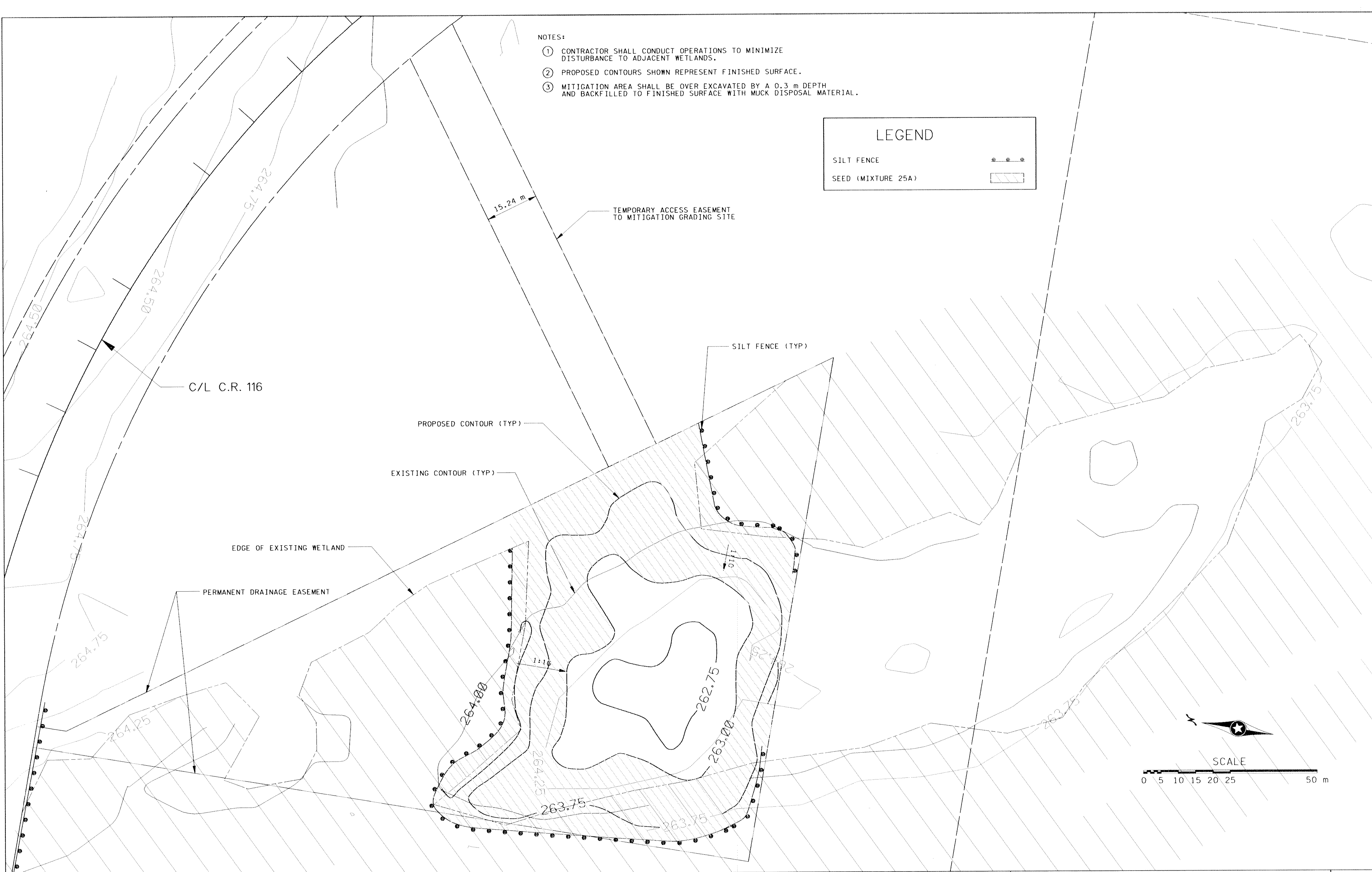

NO	DATE	BY	CKD	APPR	REVISION
NAME: 2953.CNA DATE: May. 20, 1998 TIME: 16:43:17					



I hereby certify that this plan, specification or report was prepared by me or under my direct supervision and that I am a duly Registered Professional Engineer under the laws of the State of Minnesota.

Michael D. Han
 Date: 6-25-98 Reg. No. 21364

COUNTY PROJ. NO.
 95-05-116

CITY PROJECT NO.
 97-25

DRAWN BY W. ANDERSON DATE 3-98
 DESIGNED BY B. URBANEK 3-98
 CHECKED BY M. HANSEN 5-98
 COMM. NO. 0982953



ANOKA COUNTY
 WETLAND MITIGATION GRADING PLAN
 C.R. 116

SHEET 30 OF 59

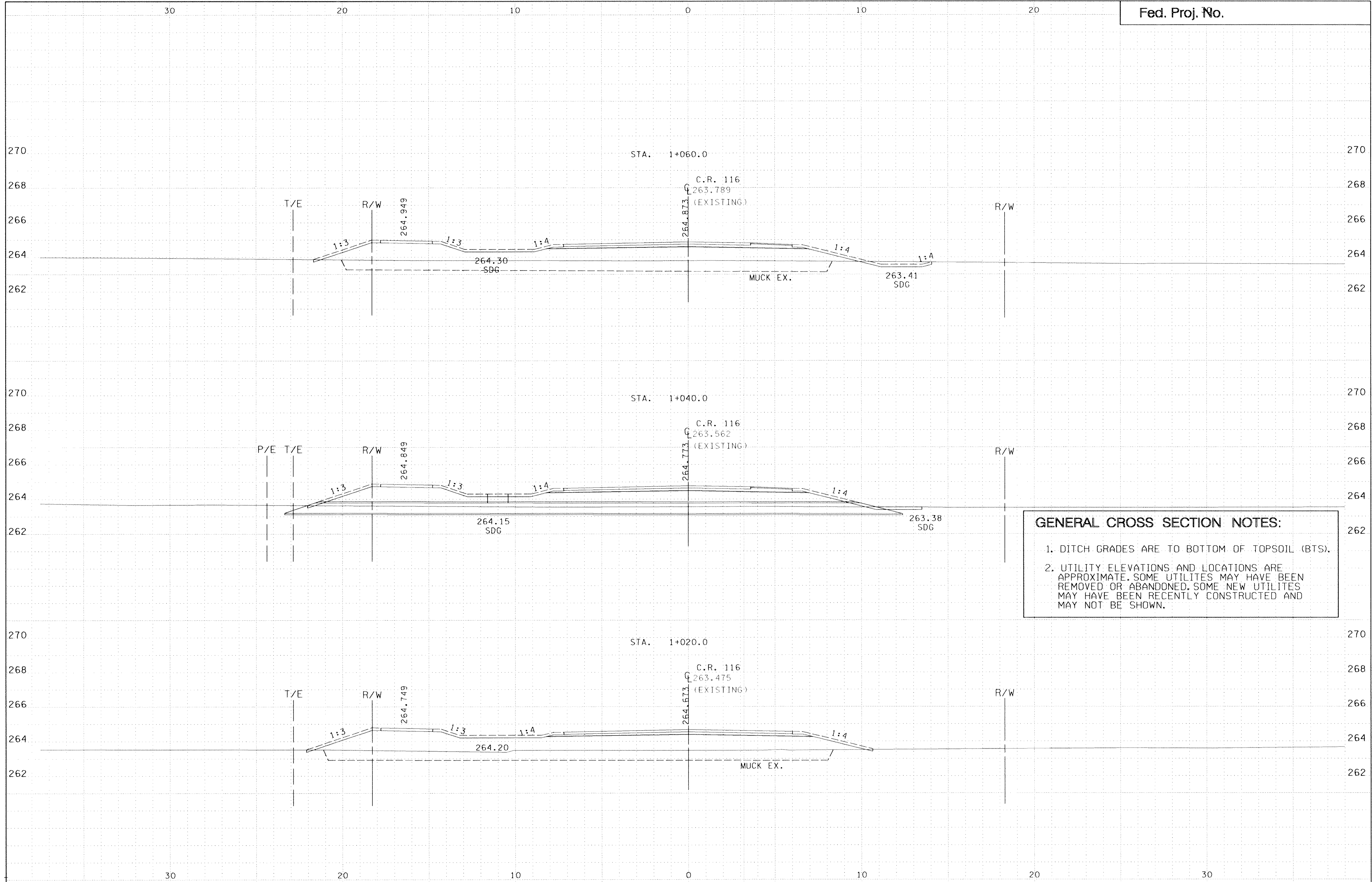

GENERAL CROSS SECTION NOTES:

1. DITCH GRADES ARE TO BOTTOM OF TOPSOIL (BTS).
2. UTILITY ELEVATIONS AND LOCATIONS ARE APPROXIMATE. SOME UTILITES MAY HAVE BEEN REMOVED OR ABANDONED. SOME NEW UTILITES MAY HAVE BEEN RECENTLY CONSTRUCTED AND MAY NOT BE SHOWN.

DESIGN FILE: H:\GIV\11047\2953\2953.dwg
 PRF FILE: H:\GIV\11047\2953\2953.dwg
 PLOTTER: M3-Des/guwer-Mono-PC-HP00T
 PLOT DATE/TIME: 06/23/98 13:55:17

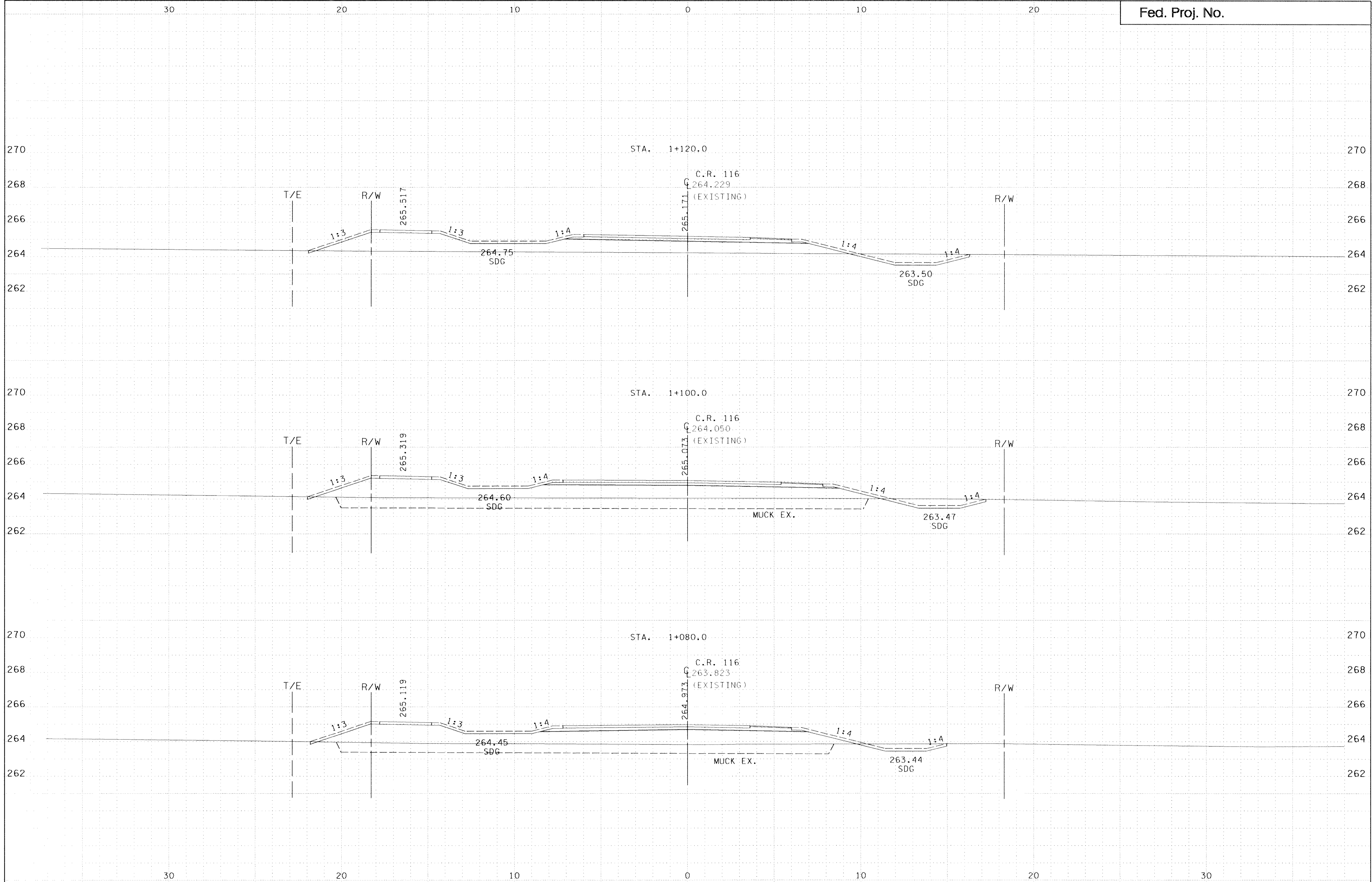

DESIGN FILE: H:\AC\11\047\2953\2953.dwg
 PLOT DATE: 06/29/98 13:54:25
 PLOTTER: MS-DesignJet-Mono-FR-WNDOT

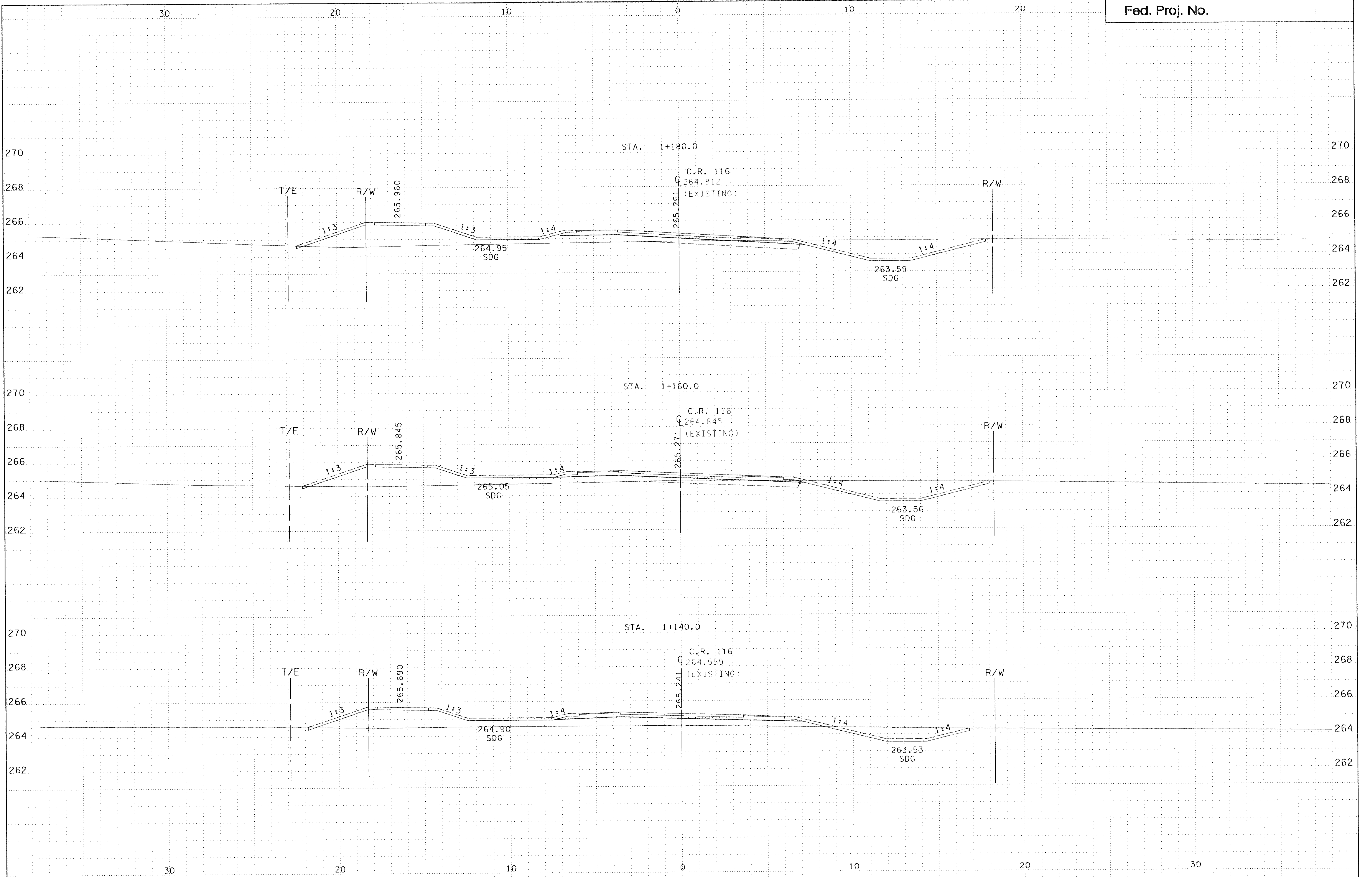

30 20 10 0 10 20

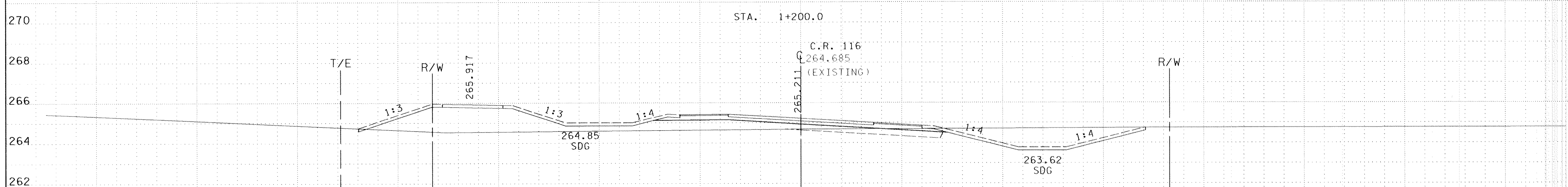
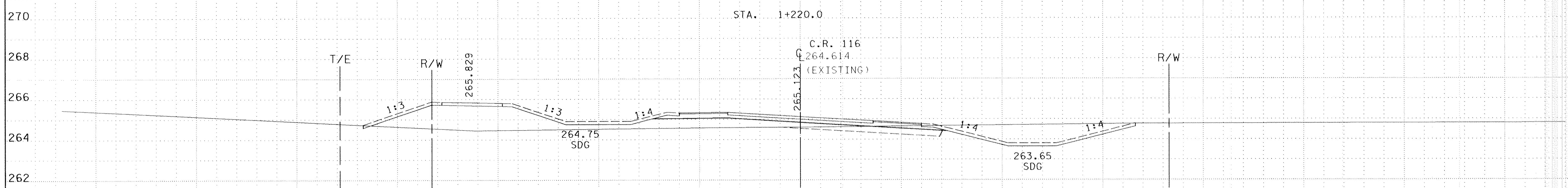
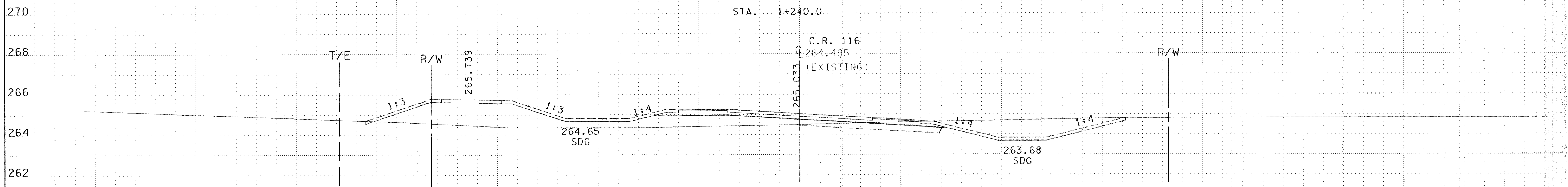

30 20 10 0 10 20 30

PRF FILE: RA CIVIL1104\2953\2953.DWG
PLOT FILE: V:\Users\gnr\2953\2953.DWG
PLOT DATE/TIME: 06/29/98 14:13:21

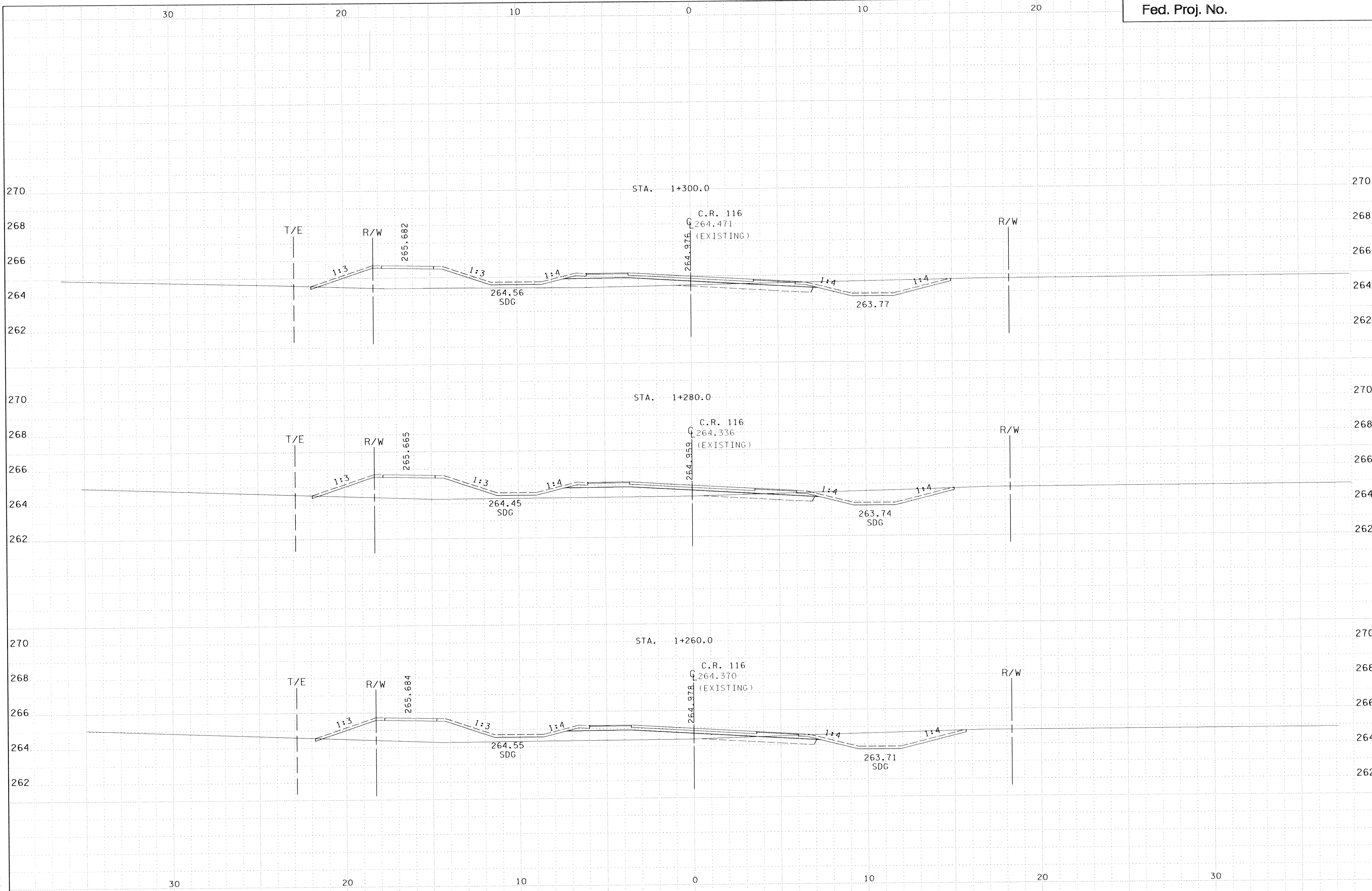

DESIGN FILE: h:\civil\1047\2953\2953.dwg
 PRF FILE: h:\civil\1047\2953\2953.dwg
 PLOT FILE: MS-DOS format, plot.dwg
 PLOT DATE/TIME: 06/23/98 14:14:00

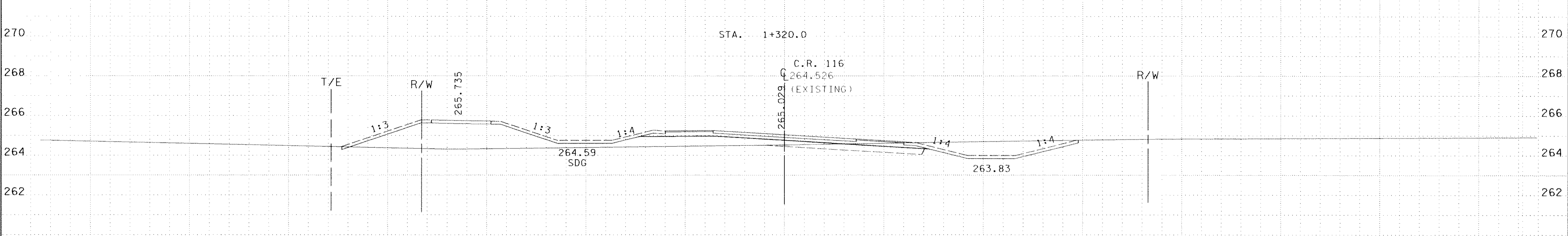
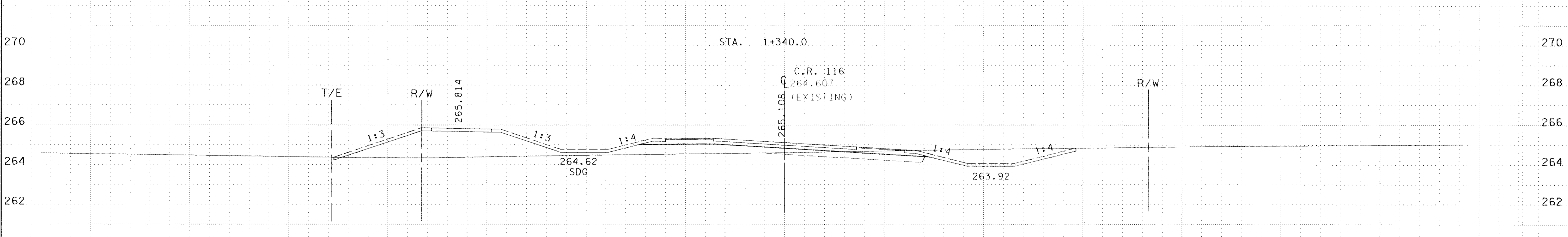
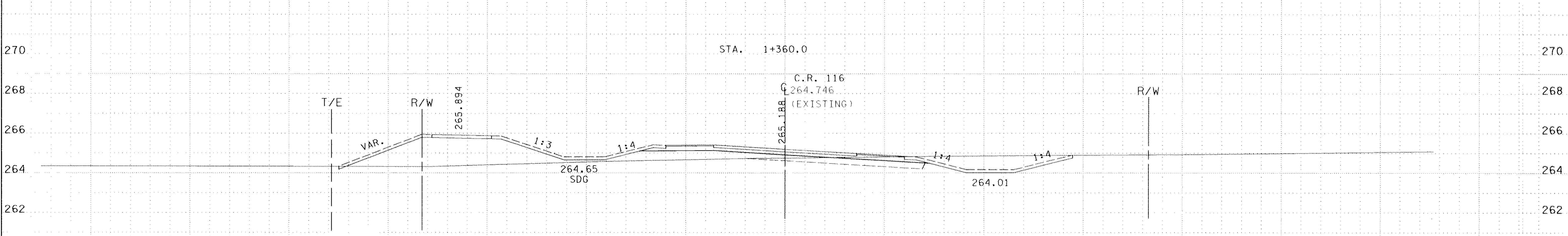
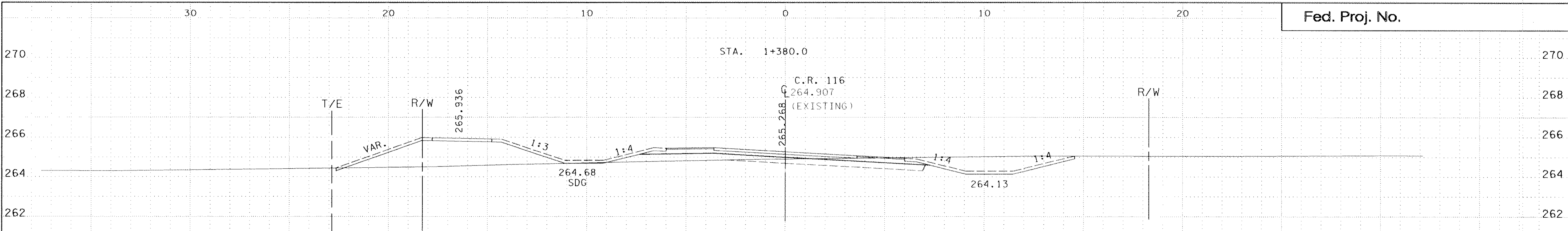

30

20

10

0

10

20

30

20

10

0

10

20

30

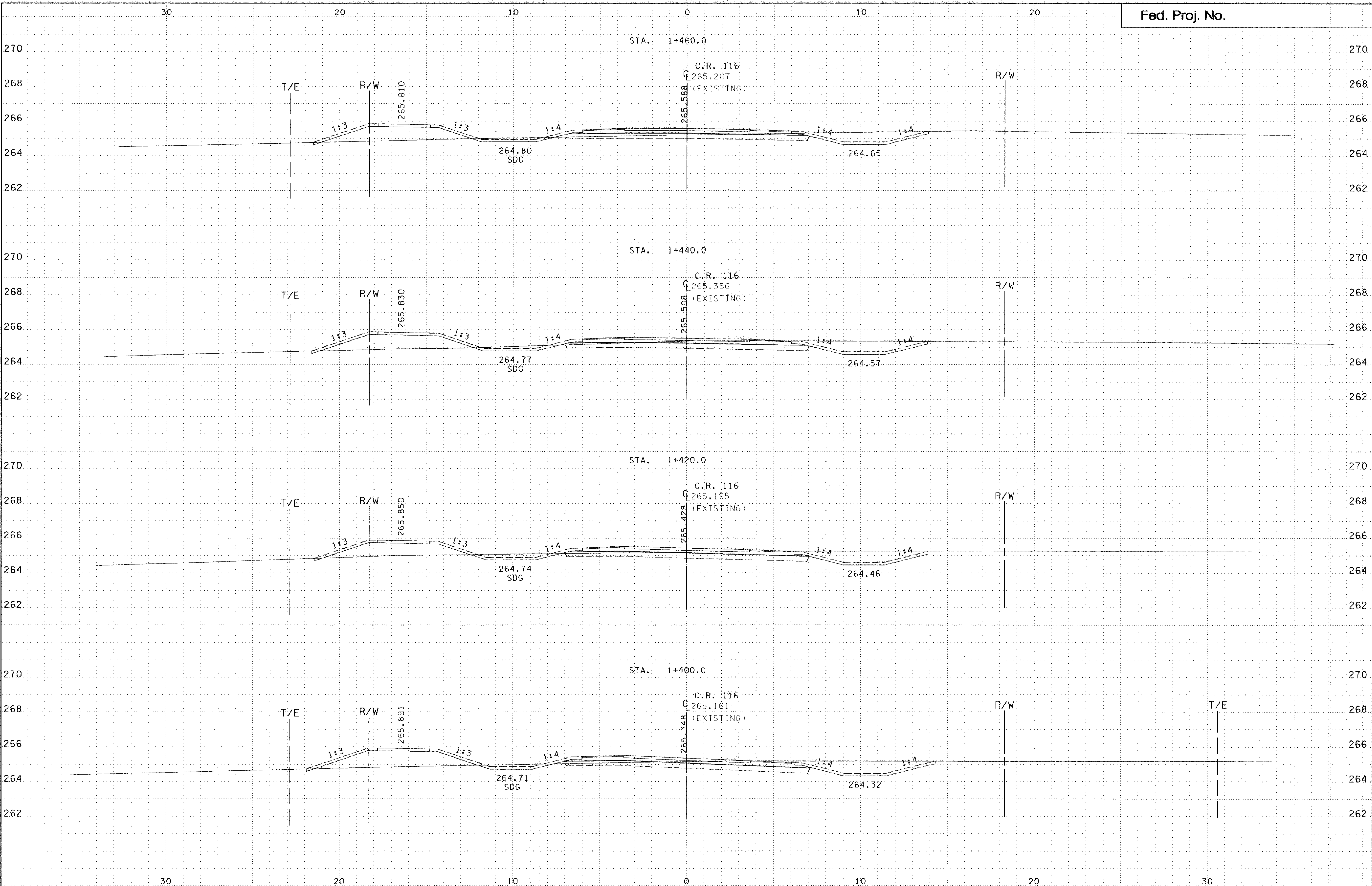

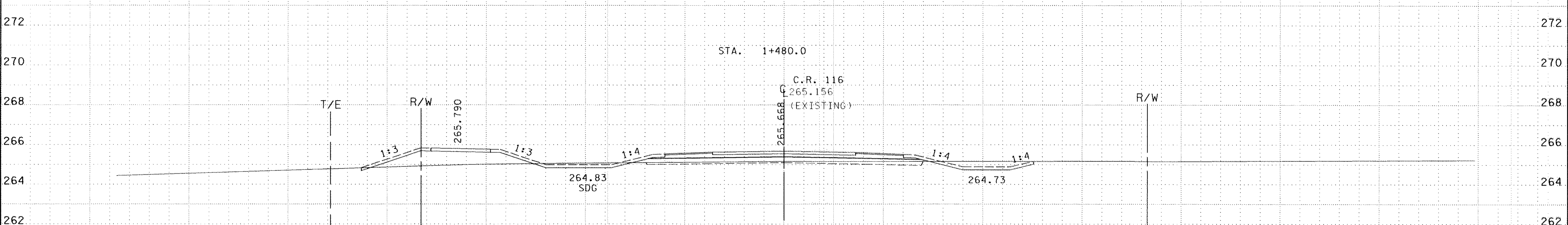
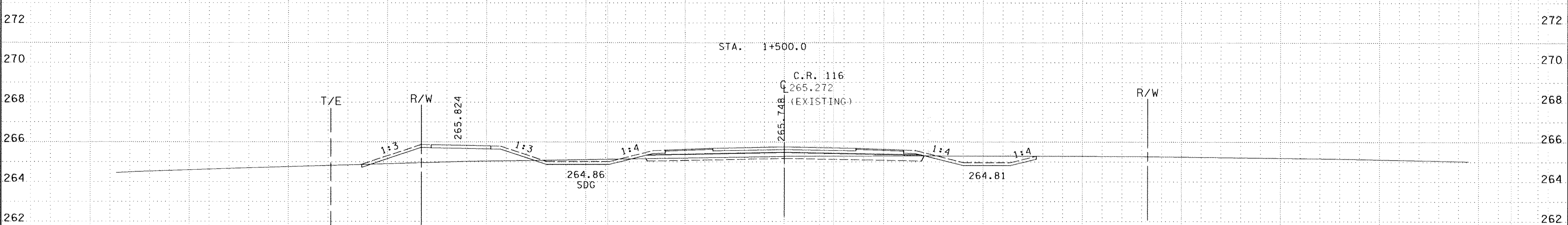
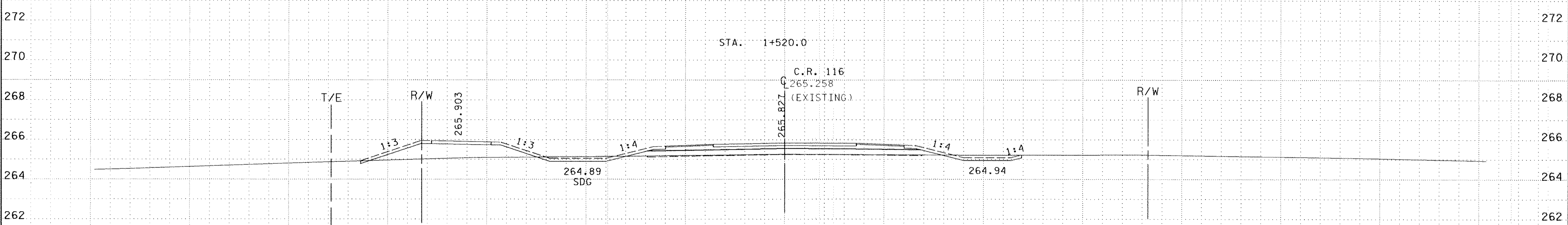
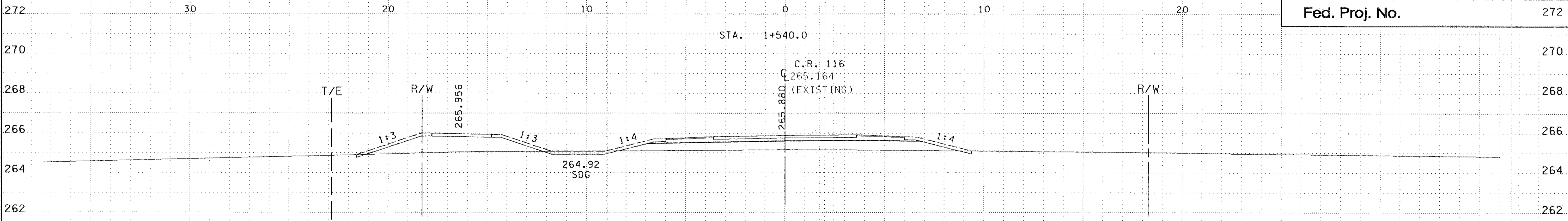

30

20

10

0

10

20

30

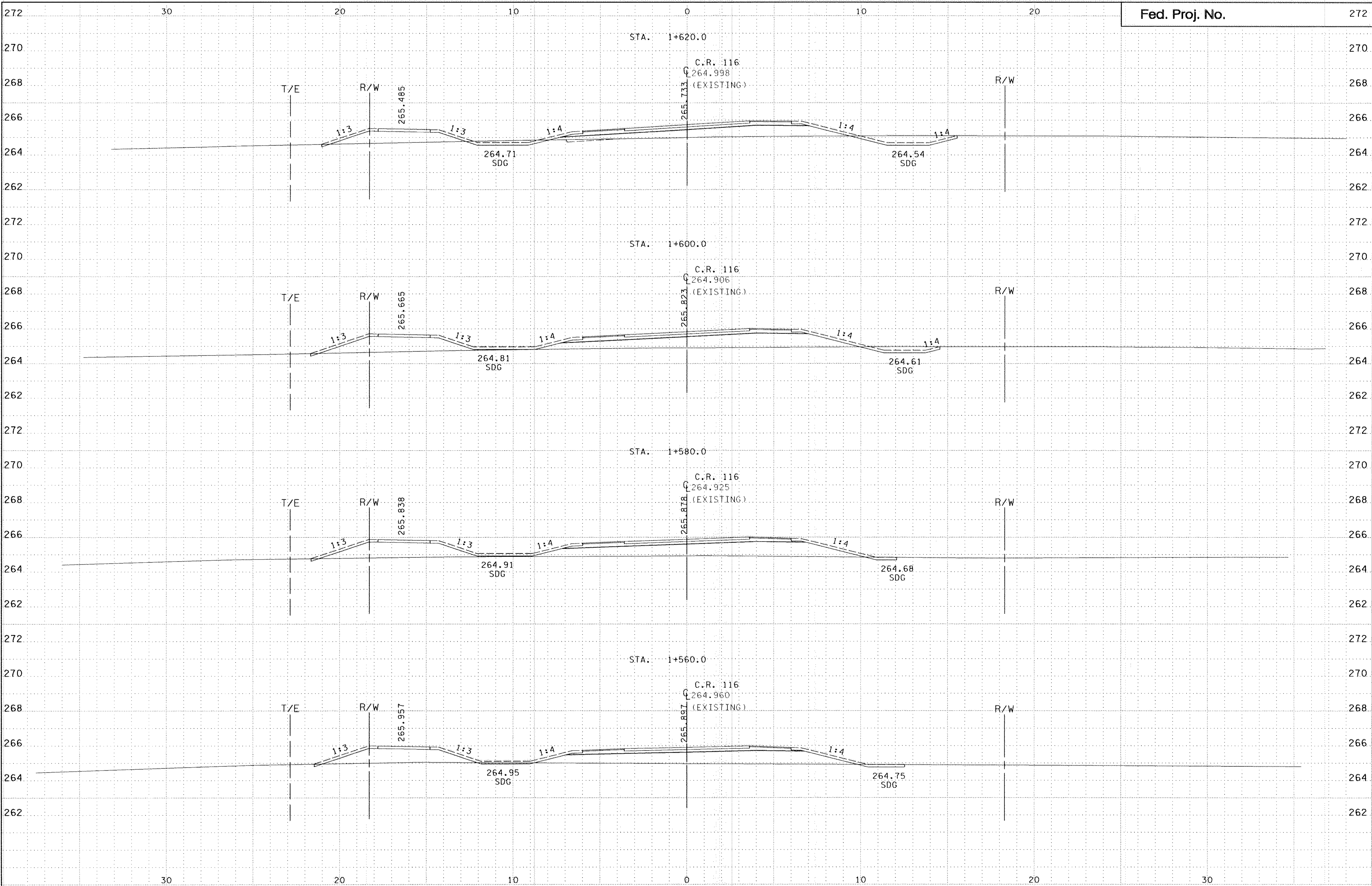

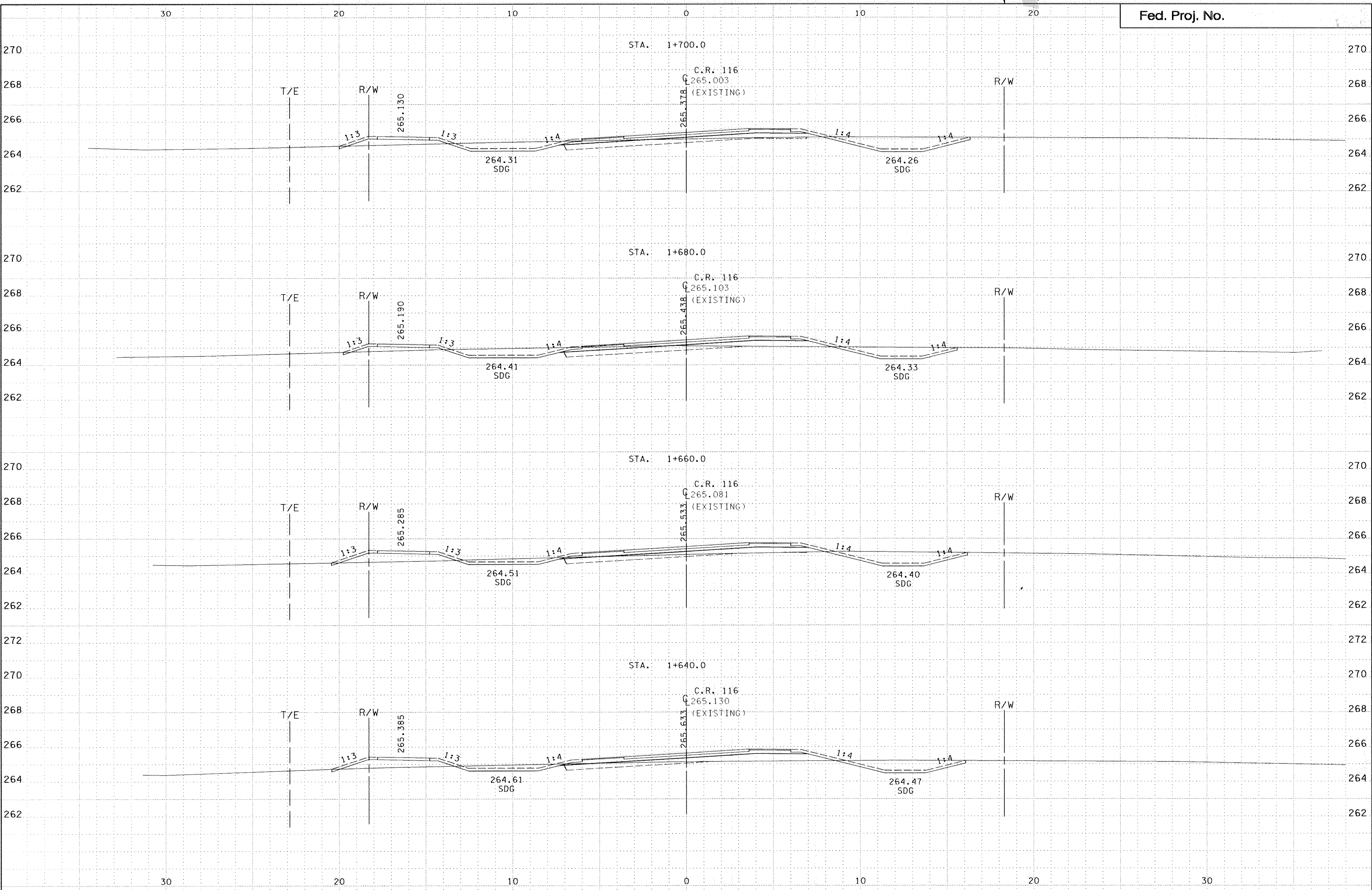

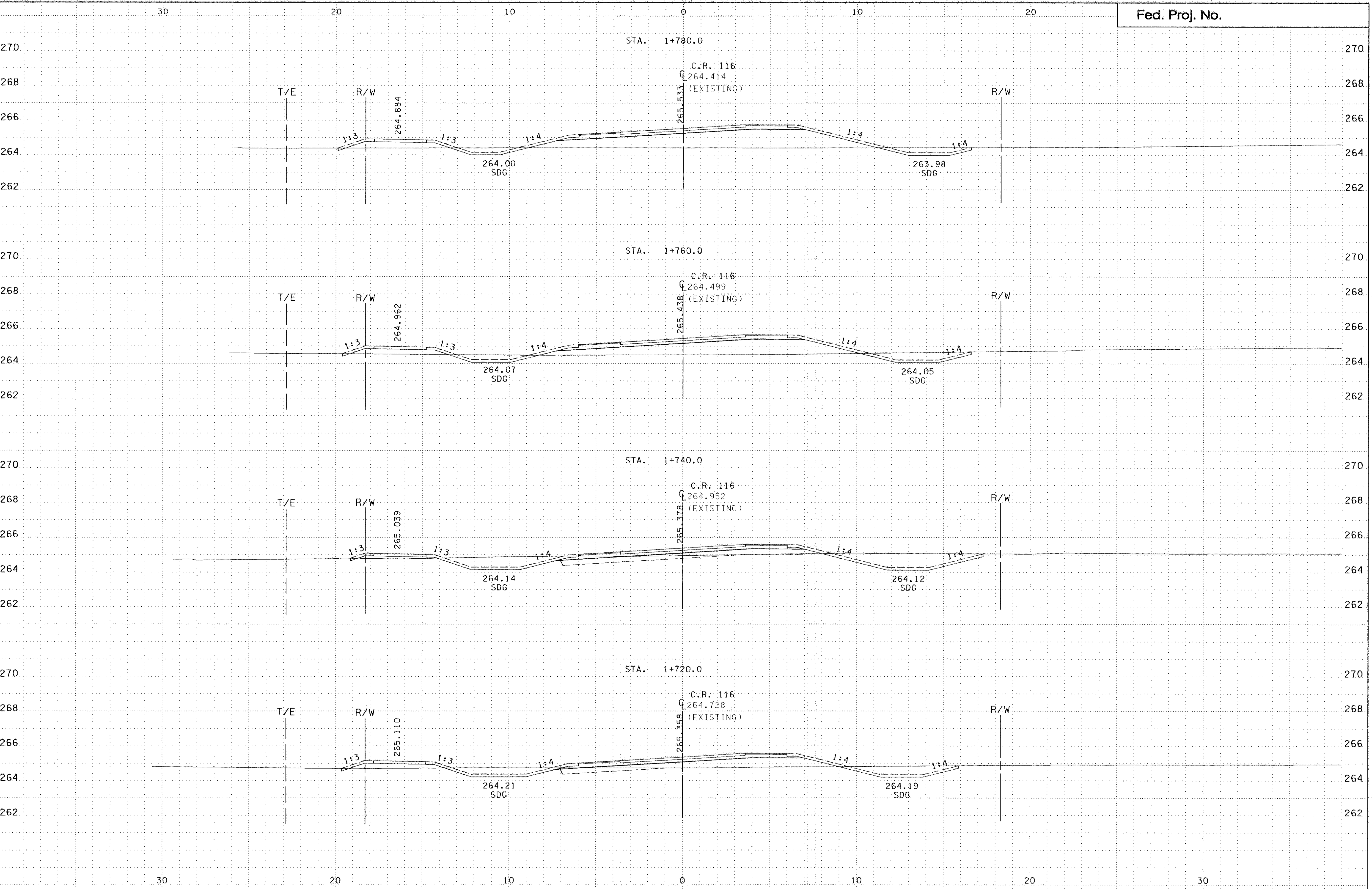

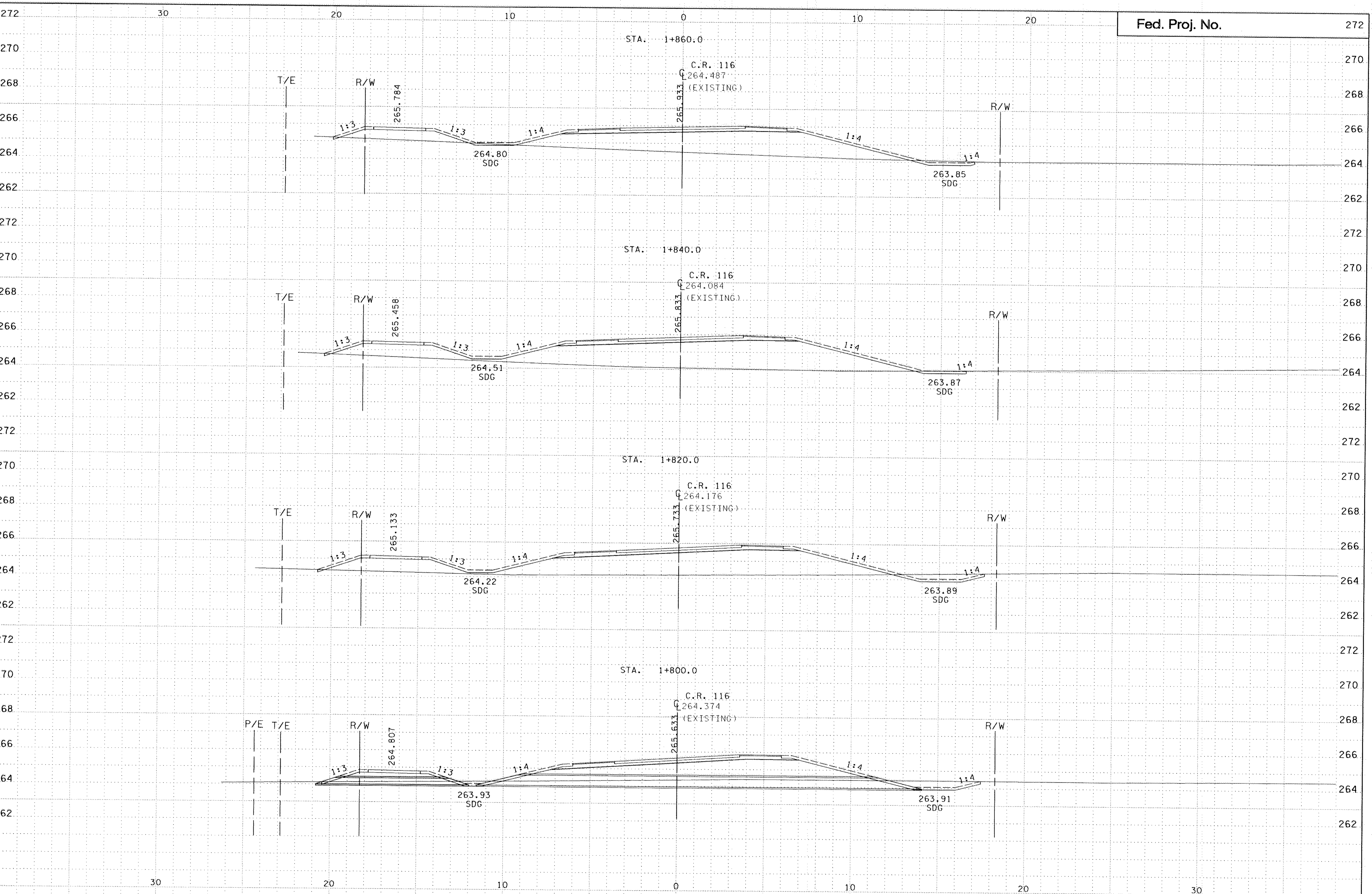

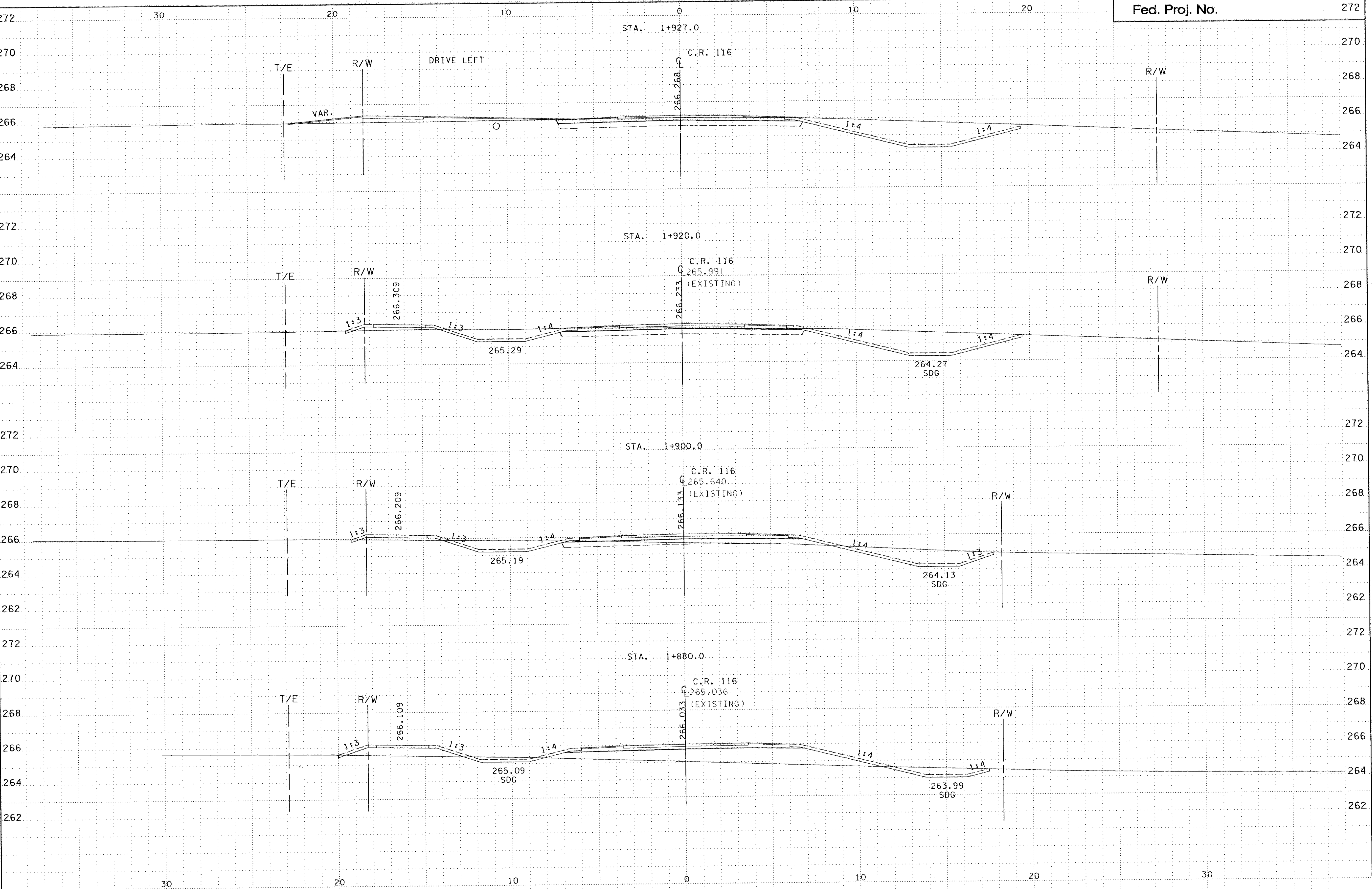

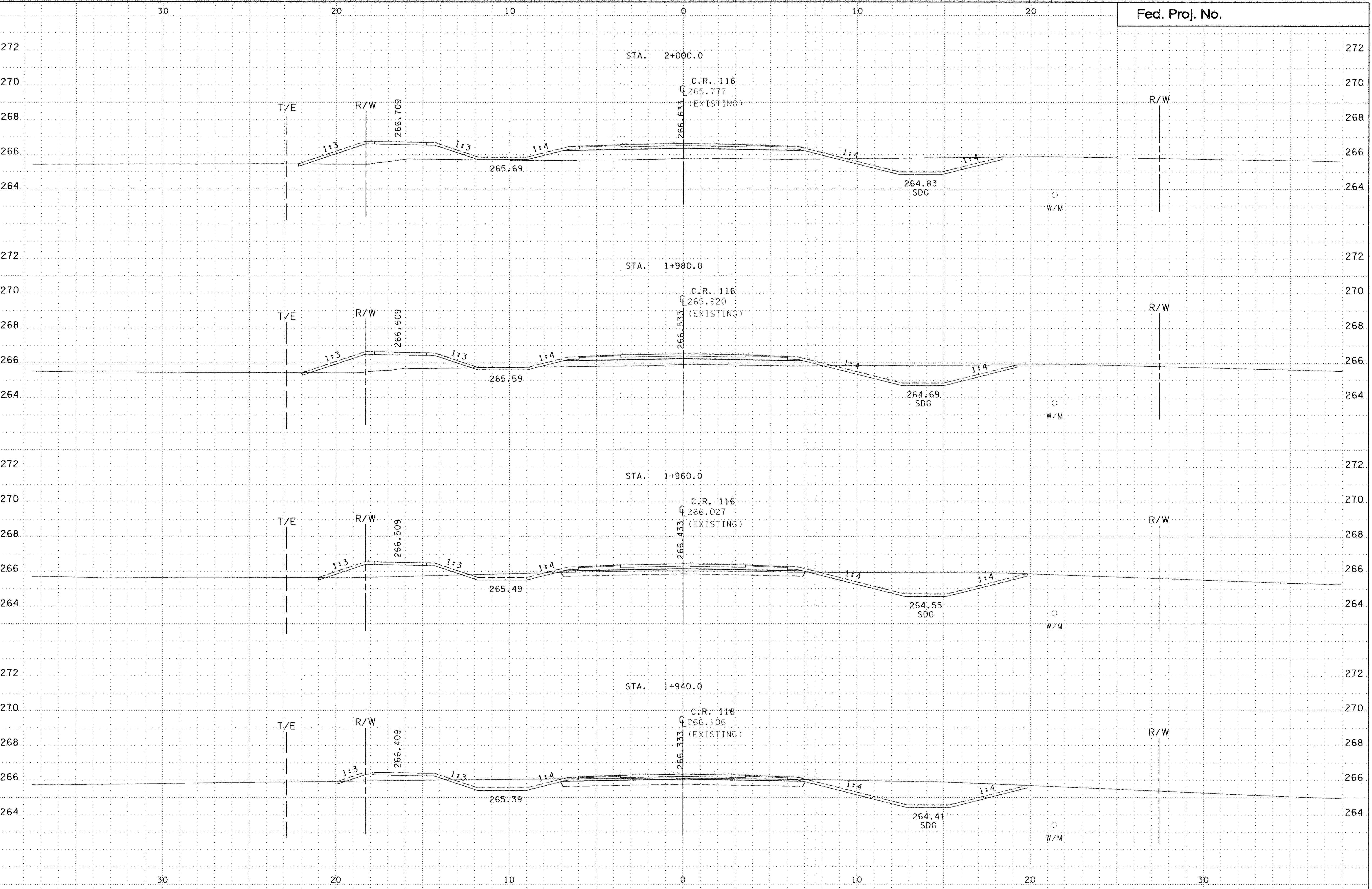

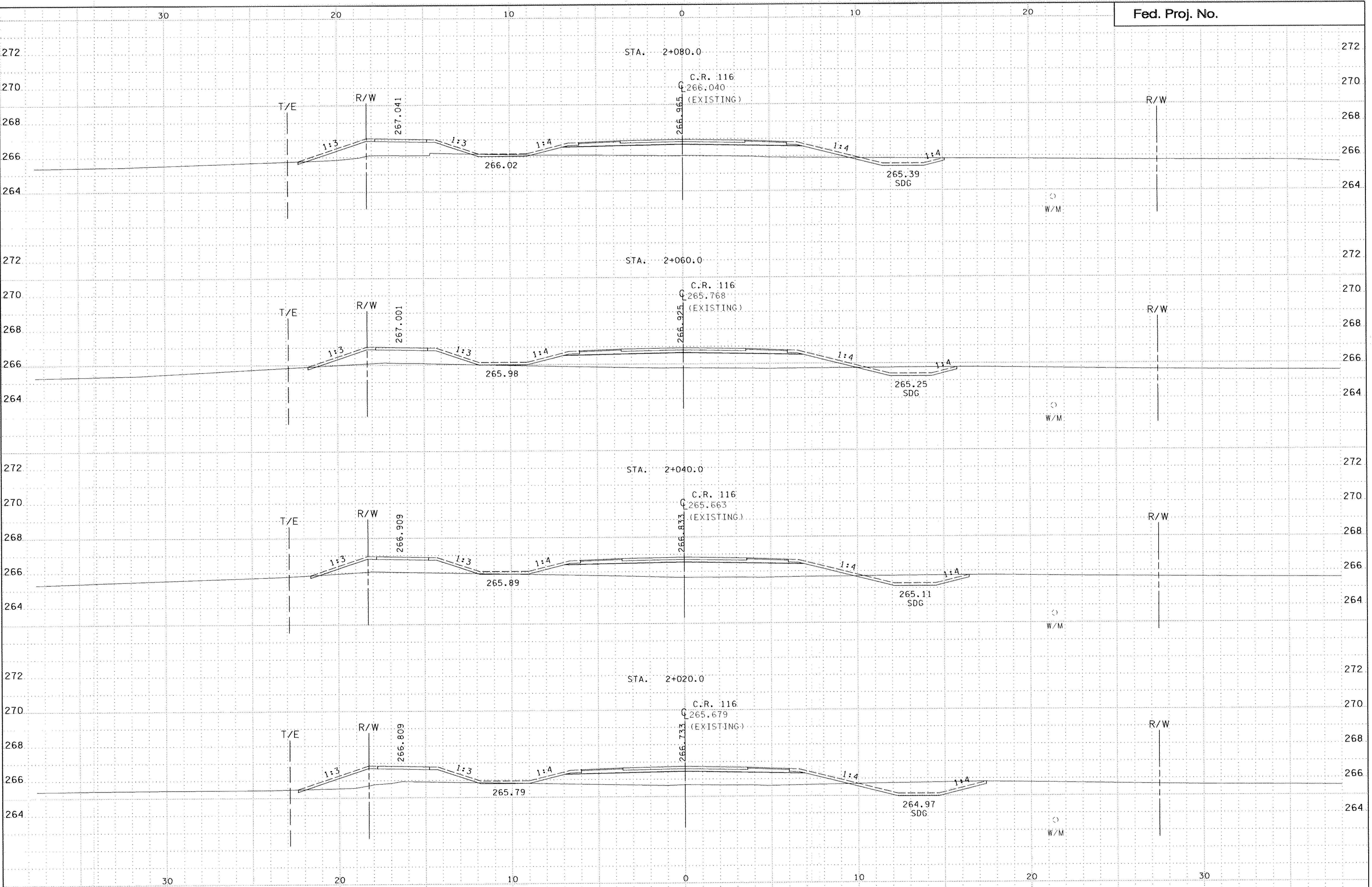

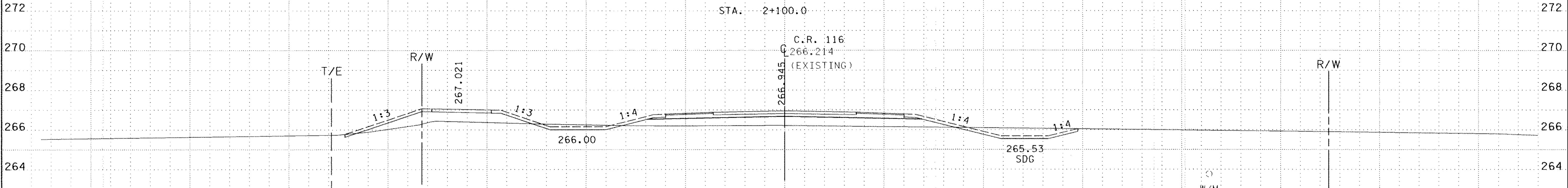
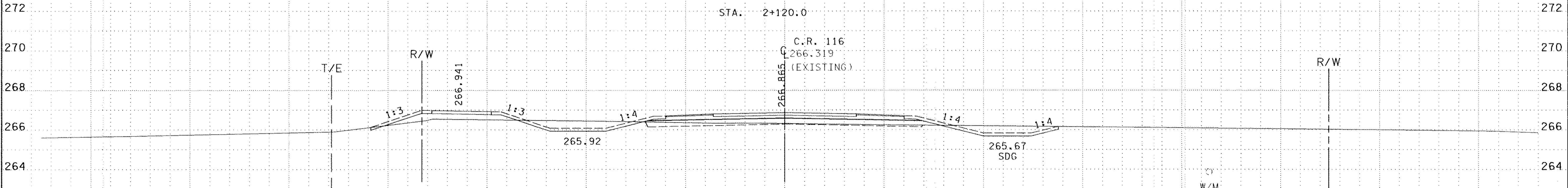
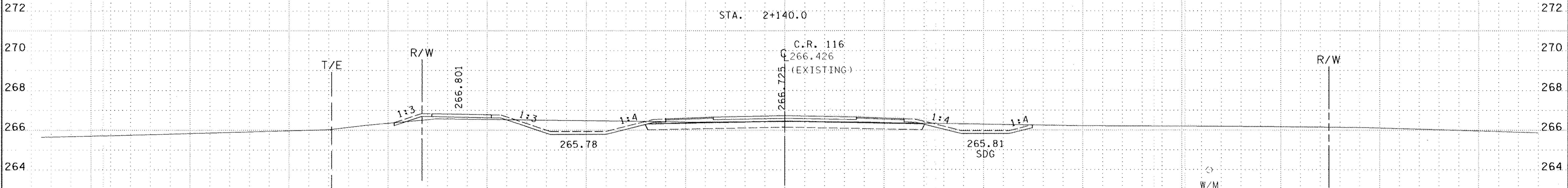
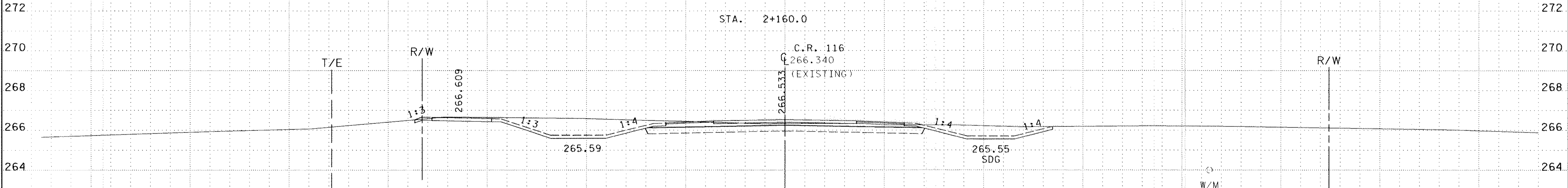

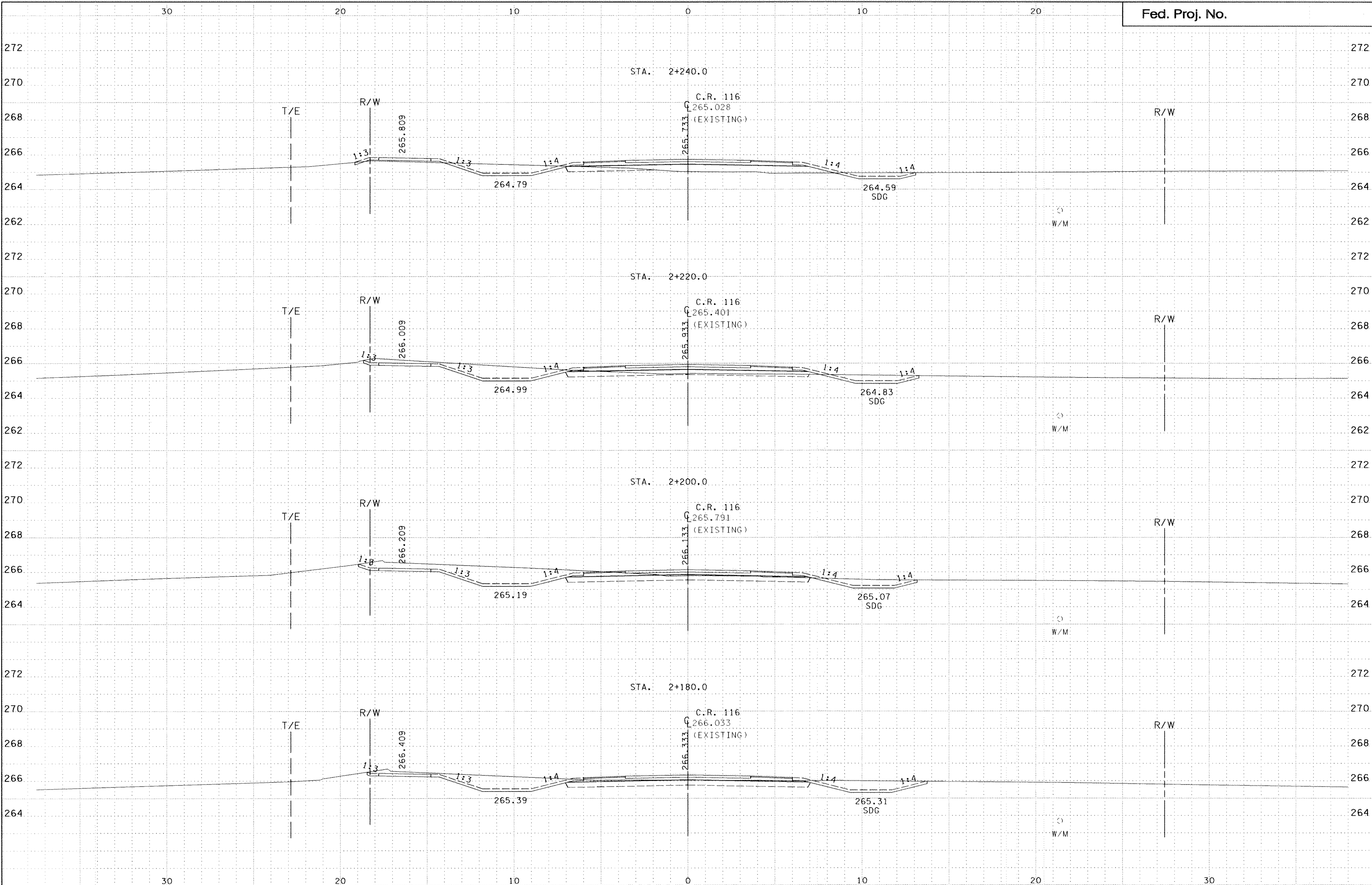

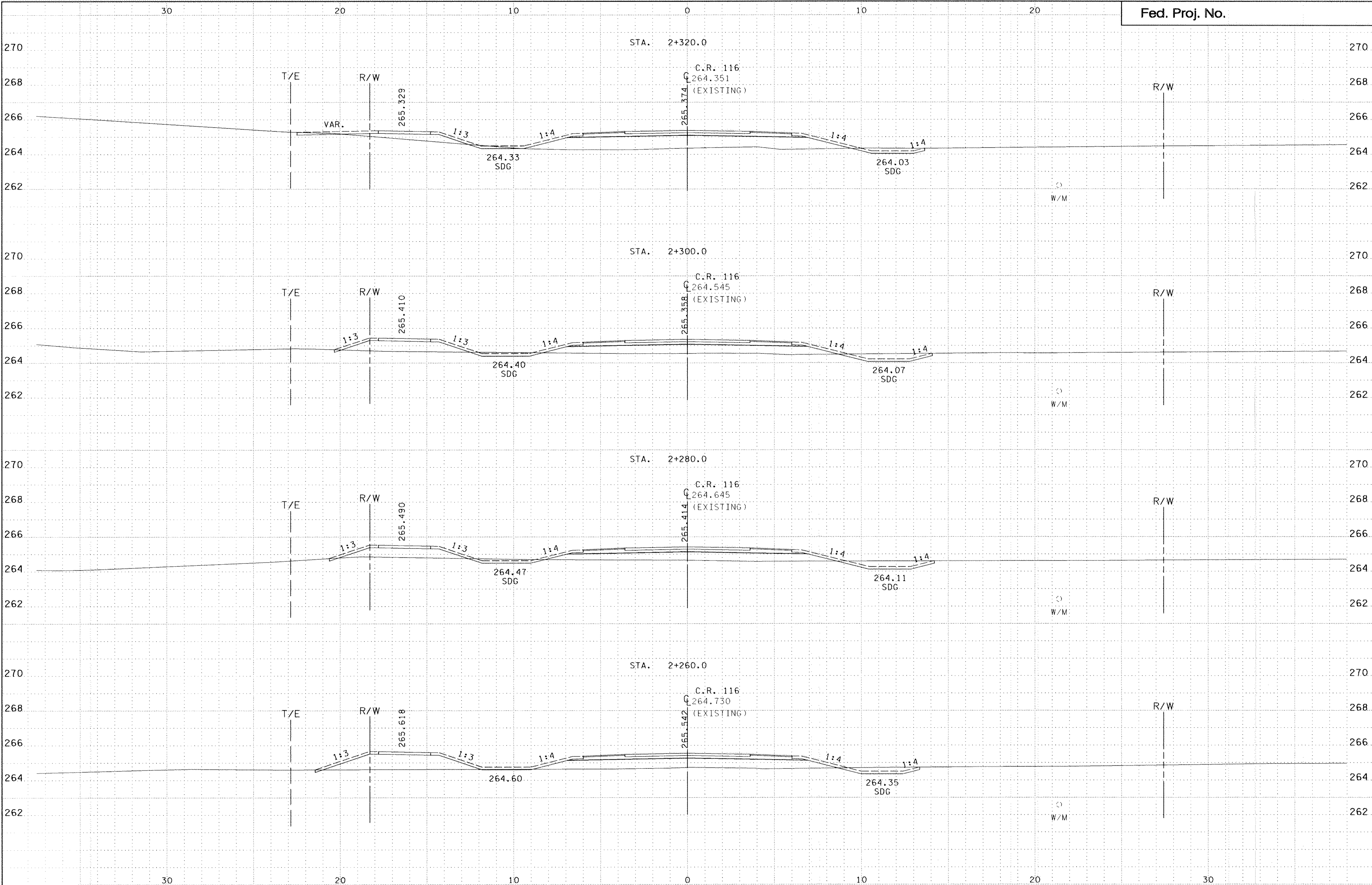

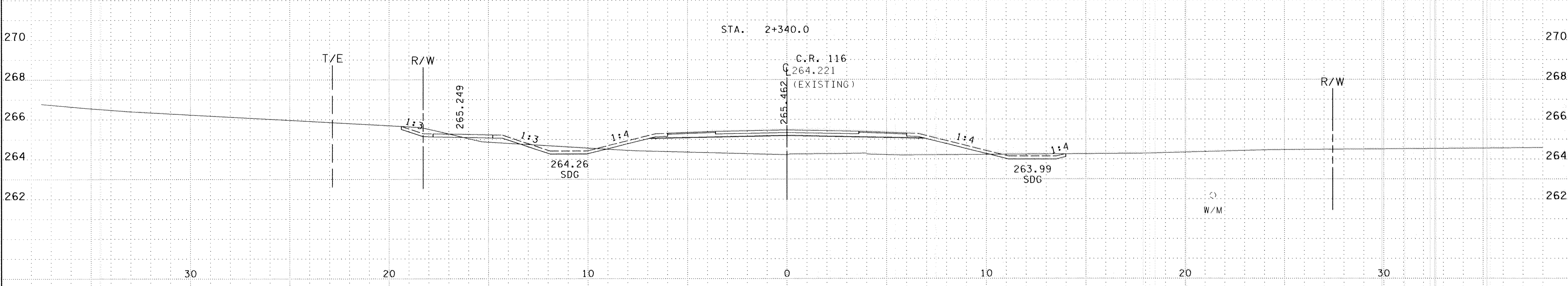
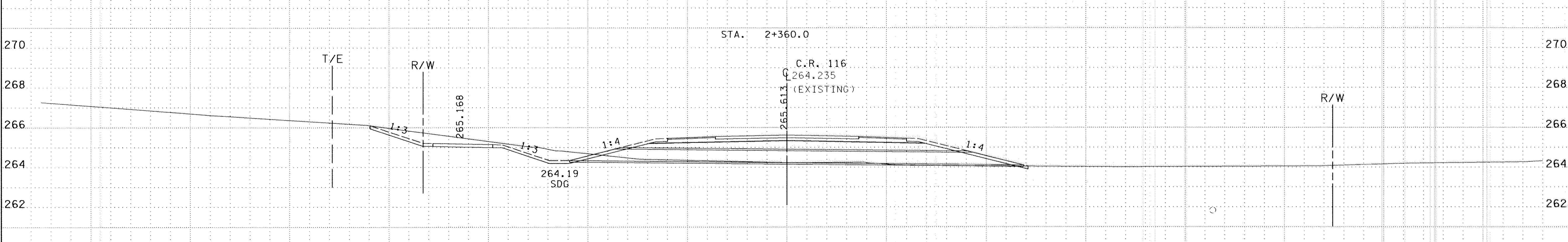
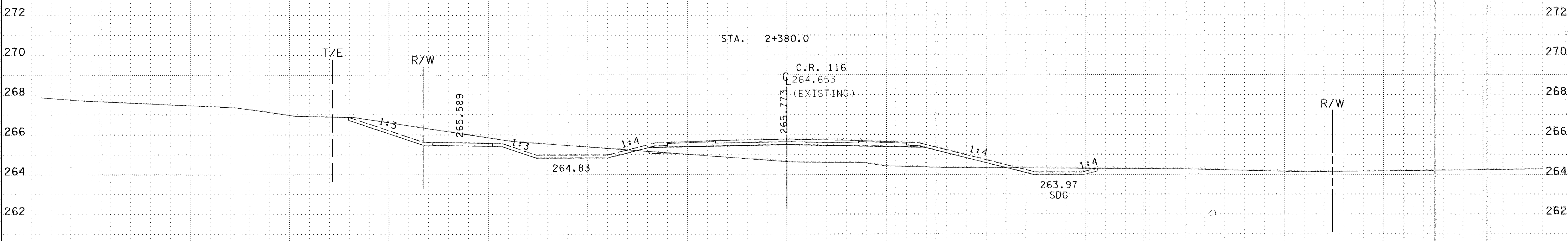
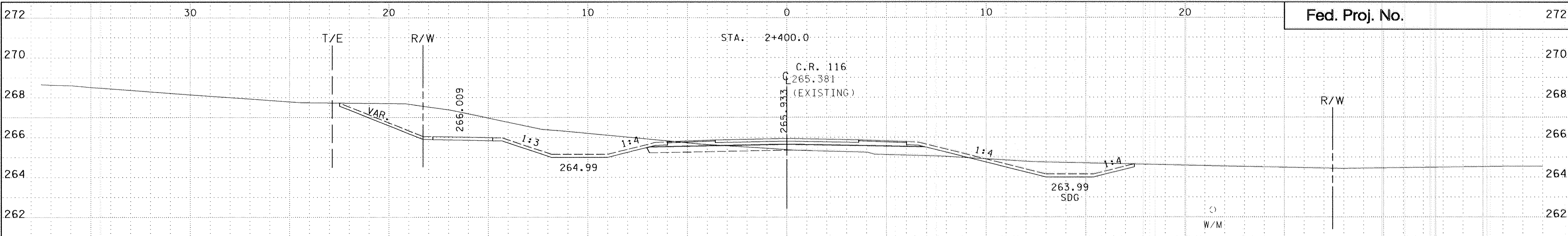

DESIGN FILE: h:\g1v1\047\2953\2953.xso
 PRF FILE: h:\g1v1\047\2953\2953.drf
 PLOTTER: MS-Dos IgaJet-Mono-FR-WNDOT
 PLOT DATE/TIME: 06/29/98 14:18:21

