

MINN. PROJ. NO. ....  
 MINN. PROJ. NO. ....

# MINNESOTA DEPARTMENT OF TRANSPORTATION

## ANOKA COUNTY

### CONSTRUCTION PLAN FOR GRADING, AGGREGATE BASE, AND BITUMINOUS SURFACING

LOCATED ON C.S.A.H. 14 BETWEEN C.S.A.H. 17 (LEXINGTON AVE.) AND 4TH AVE. IN LINO LAKES (Geographic Description)  
 A POINT 1022.67' E. OF THE NW CORNER A POINT 167.74' W. OF THE NW.  
 FROM OF SECTION 12, T31N, R23W TO CORNER OF SECTION 8, T31N, R22W (Legal Description)

STATE AID PROJ. NO. 02-614-15	STATE AID PROJ. NO. ....
GROSS LENGTH 9,258.00 FEET 1.753 MILES	GROSS LENGTH FEET MILES
BRIDGES-LENGTH 0.00 FEET 0.000 MILES	BRIDGES-LENGTH FEET MILES
EXCEPTIONS-LENGTH 0.00 FEET 0.000 MILES	EXCEPTIONS-LENGTH FEET MILES
NET LENGTH 9,258.00 FEET 1.753 MILES	NET LENGTH FEET MILES

#### GOVERNING SPECIFICATIONS

THE 1988 EDITION OF THE MINNESOTA DEPARTMENT OF TRANSPORTATION "STANDARD SPECIFICATIONS FOR CONSTRUCTION" AS AMENDED BY SUPPLEMENTAL SPECIFICATIONS, DATED MAY 2, 1994 SHALL GOVERN.

### INDEX

SHEET NO.	DESCRIPTION
1	TITLE SHEET
2	STATEMENT OF ESTIMATED QUANTITIES
3-5	TABULATION CHARTS
6	EARTHWORK SUMMARY AND CONST. NOTES
7	STANDARD DETAILS
8-9	EROSION CONTROL DETAILS
10	TYPICAL SECTIONS
11-17	PLAN AND PROFILE SHEETS
18-19	(INTENTIONALLY OMITTED)
20-23	TURF ESTABLISHMENT PLANS
24-38	CROSS-SECTION SHEETS
39-40	DETOUR SIGNING
41	SHORT TERM LANE CLOSURE

THIS PLAN CONTAINS 39 SHEETS

#### DESIGN DESIGNATION

EN18<sub>20</sub> 1,222,387  
 R VALUE 60  
 ADT (1994)= 6,167  
 Proj. ADT (2014)= 10,484  
 Proj. HCADT (2014)= 786  
 Soil Factor NA  
 10 TON DESIGN  
 Shoulder Width 12 FT.  
 Functional Classification  
 No. of Traffic Lanes 2 No. of Parking Lanes 0  
 Design Speed 55 MPH  
 Based on Stopping Sight Distance  
 Height of eye 3.5 Height of object 0.5  
 Design Speed not achieved at: N.A.  
 STA. TO STA. MPH  
 STA. TO STA. MPH  
 STA. TO STA. MPH

I HEREBY CERTIFY THAT THIS PLAN WAS PREPARED BY ME OR UNDER MY DIRECT SUPERVISION AND THAT I AM A DULY REGISTERED PROFESSIONAL ENGINEER UNDER THE LAWS OF THE STATE OF MINNESOTA.

DATE 5/23/94 REG. NO. 20235 ENGR. *Douglas W. Jensen* DESIGN ENGINEER

DESIGN SQUAD GREG ANDERSON

Recommended for Approval *Michael R. Kelly* DIST. OF HIGHWAY SECTION 6/2 1994  
 Recommended for Approval *Gene P. Jensen* TRAFFIC SECTION 6/2 1994  
 Recommended for Approval *Greg Anderson* CONSTRUCTION ENGINEER 9/2 1994  
 Recommended for Approval *Jan A. Olson* DEPUTY COUNTY ENGINEER 6/3 1994  
 Approved 6/3 1994 *Jan A. Olson* ANOKA COUNTY ENGINEER  
 Approved 6/16 1994 *Douglas W. Jensen* ANOKA COUNTY ENGINEER  
 Recommended for Approval *Mary A. Quinlan* METAL ASSISTANT DISTRICT ENGINEER-STATE AID 6/9 1994  
 Recommended for Approval *Paul D. Murphy* STATE AID PLANS AND SPECS ENGINEER 6-15 1994  
 Approved 6-15 1994 *Paul D. Murphy* STATE AID ENGINEER

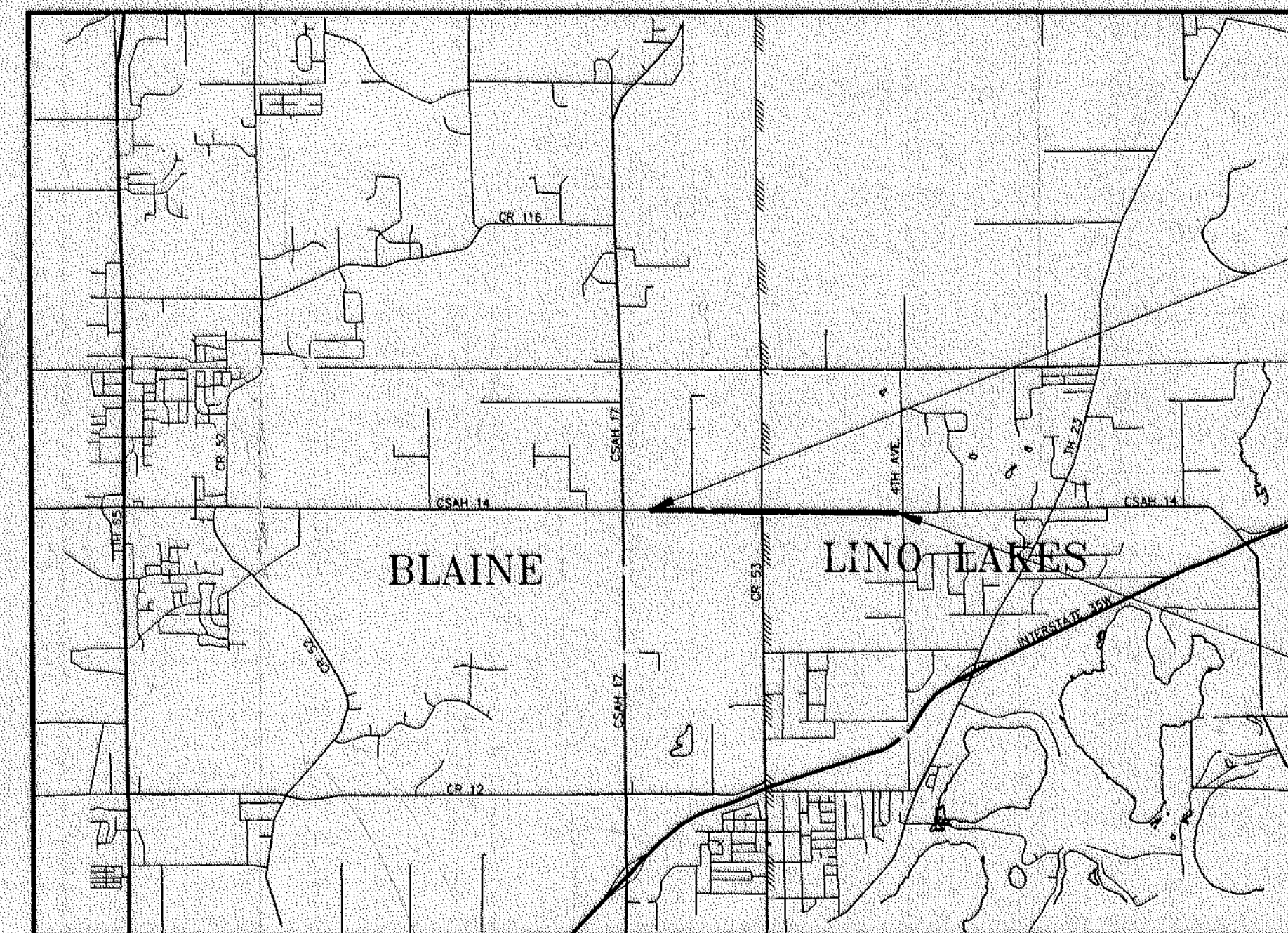

BEGIN S.A.P. 02-614-15  
 STATION 199+67.00

END S.A.P. 02-614-15  
 STATION 292+25.00

#### PLAN SYMBOLS

- COUNTY LINE.....
- TOWNSHIP OR RANGE LINE.....
- SECTION LINE.....
- QUARTER LINE.....
- SIXTEENTH LINE.....
- RIGHT OF WAY LINE.....
- SLOPE EASEMENT.....
- PRESENT RIGHT OF WAY.....
- PROPERTY LINE.....
- CORPORATE OR CITY LIMITS.....
- RETAINING WALL.....
- RAILROAD.....
- RAILROAD RIGHT OF WAY.....
- RIVER OR CREEK.....
- DRAINAGE DITCH.....
- CULVERT.....
- DROP INLET.....
- GAURD RAIL.....
- BARBED WIRE FENCE.....
- WOVEN WIRE FENCE.....
- CHAIN LINK FENCE.....
- WOOD FENCE.....
- STONE WALL OR FENCE.....
- HEDGE.....
- LOWLAND.....
- TIMBER.....
- ORCHARD.....
- BRUSH.....
- NURSERY.....
- CATTLE GAURD.....
- OVERPASS (Highway Over).....
- UNDERPASS (Highway Under).....
- BRIDGE.....
- BUILDING (One Story Frame).....
- F-FRAME C-CONCRETE
- S-STONE T-TILE
- B-BRICK ST-STUCCO
- RAILROAD CROSSING BELL.....
- RAILROAD CROSSING GATE.....
- MANHOLE.....
- CATCH BASIN.....
- FIRE HYDRANT.....
- CAST IRON MONUMENT.....
- IRON PIN.....
- GRAVEL PIT.....
- SAND PIT.....
- BORROW PIT.....
- ROCK QUARRY.....

#### UTILITY SYMBOLS

- POWER POLE LINE.....
- TELEPHONE OR TELEGRAPH POLE LINE.....
- JOINT TELEPHONE & POWER ON POWER POLES.....
- ON TELEPHONE POLES.....
- ANCHOR.....
- STEEL TOWER.....
- STREET LIGHT.....
- PEDESTAL (Cable Terminal).....
- GAS MAIN.....
- WATER MAIN.....
- TELEPHONE CABLE IN CONDUIT.....
- ELECTRIC CABLE IN CONDUIT.....
- TELEPHONE MANHOLE.....
- ELECTRIC MANHOLE.....
- BURIED TELEPHONE CABLE.....
- BURIED ELECTRIC CABLE.....
- AERIAL TELEPHONE CABLE.....
- SEWER (Sanitary or Storm).....
- SEWER MANHOLE.....

#### SCALES

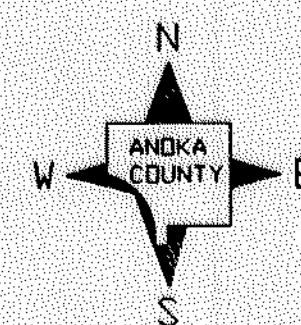
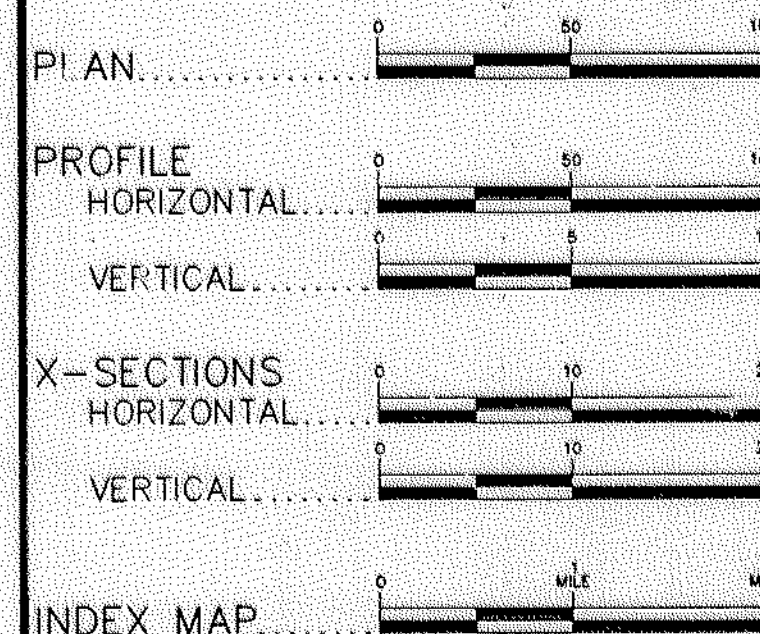

STATE AID PROJ. NO. 02-614-15  
 STATE PROJ. NO. .... SHEET NO. 1 OF 41 SHEETS



STATEMENT OF ESTIMATED QUANTITIES

CHART NO.	NOTE	ITEM NO.	ITEM	UNIT	SAP 02-614-15		TOTAL	
					ESTIMATED	FINAL	ESTIMATED	FINAL
		2021.501	MOBILIZATION	LUMP SUM	1		1	
		2031.501	FIELD OFFICE, TYPE D	EACH	1		1	
A		2101.501	CLEARING	ACRE	1.35		1.35	
A		2101.502	CLEARING	TREE	51		51	
A		2101.506	GRUBBING	ACRE	1.35		1.35	
A		2101.507	GRUBBING	TREE	53		53	
I	(1)	2104.501	REMOVE PIPE SEWER (STORM)	LIN FT	53		53	
H	(1)	2104.501	REMOVE CULVERT PIPE	LIN FT	1,540		1,540	
D	(2)	2104.505	REMOVE BITUMINOUS PAVEMENT	SQ YD	25,387		25,387	
E	(1)	2104.505	REMOVE RIPRAP	SQ YD	26		26	
E	(1)	2104.505	REMOVE CONCRETE PAVEMENT	SQ YD	10		10	
I	(1)	2104.509	REMOVE CONCRETE APRON	EACH	1		1	
G		2104.513	SAVING BITUMINOUS PAVEMENT	LIN FT	180		180	
F		2104.521	SALVAGE GUARD RAIL	LIN FT	1,468		1,468	
F	(1)	2104.521	SALVAGE FENCE	LIN FT	4,946		4,946	
I		2104.523	SALVAGE CONCRETE APRON	EACH	1		1	
N		2105.501	COMMON EXCAVATION	CU YD	21,629(P)		21,629(P)	
N		2105.505	MUCK EXCAVATION	CU YD	122,030		122,030	
N		2105.522	GRANULAR BORROW (LV)	CU YD	130,532		130,532	
N	(10)	0105.603	MUCK EXCAVATION SPECIAL	CU YD	7,390		7,390	
	(3)	2130.501	WATER	M-GAL	350		350	
L	(8)	2211.503	AGGREGATE BASE (C.V.) CL 5A	CU YD	7,678(P)		7,678(P)	
B	(4)	0340.601	2" THICK WEARING COURSE PLACED	SQ YD	2,526		2,526	
L		2340.508	TYPE 41 WEARING COURSE MIXTURE	TON	4,111		4,111	
L	(11)	2340.510	TYPE 41 BINDER COURSE MIXTURE	TON	4,895		4,895	
L	(11)	2340.514	TYPE 31 BASE COURSE MIXTURE	TON	7,032		7,032	
L		2357.502	BITUMINOUS MATERIAL FOR TACK COAT	GALLON	6,372		6,372	
H		2451.509	AGGREGATE BEDDING (LV)	CU YD	221		221	
H		2501.511	15" CS PIPE CULVERT	LIN FT	270		270	
H		2501.511	18" CS PIPE CULVERT	LIN FT	546		546	
H		2501.511	24" CS PIPE CULVERT	LIN FT	252		252	
H		2501.511	30" CS PIPE CULVERT	LIN FT	290		290	
H		2501.511	36" CS PIPE CULVERT	LIN FT	124		124	
H		2501.511	42" CS PIPE CULVERT	LIN FT	60		60	
H		2501.511	24" RC PIPE CULVERT	LIN FT	236		236	
H		2501.511	60" RC PIPE CULVERT	LIN FT	86		86	
H		2501.515	24" RC PIPE APRON	EACH	6		6	
I		2501.515	36" RC PIPE APRON	EACH	1		1	
H		2501.515	60" RC PIPE APRON	EACH	2		2	
H		2501.567	15" CS SAFETY APRON & GRATE, DES. 3148	EACH	12		12	
H		2501.567	18" CS SAFETY APRON & GRATE, DES. 3148	EACH	22		22	
H		2501.567	24" CS SAFETY APRON & GRATE, DES. 3148	EACH	8		8	
H		2501.567	30" CS SAFETY APRON & GRATE, DES. 3148	EACH	10		10	
H		2501.567	36" CS SAFETY APRON & GRATE, DES. 3148	EACH	4		4	
H		2501.567	42" CS SAFETY APRON & GRATE, DES. 3148	EACH	2		2	
I		2501.573	INSTALL 15" RC PIPE APRON	EACH	1		1	
I		2503.541	15" RC PIPE SEWER, DESIGN 3006	LIN FT	4		4	
I		2503.541	36" RC PIPE SEWER, DESIGN 3006	LIN FT	155		155	
I		0503.602	CONNECT TO EXISTING MANHOLE	EACH	1		1	
I		2506.501	CONST. DRAINAGE STRUCT. DESIGN 60-4020	LIN FT	6.3		6.3	
I		2506.516	CASTING ASSEMBLY	EACH	1		1	
I	(12)	2506.522	ADJUST FRAME & RING CASTING (STORM)	EACH	3		3	
H,I		2511.501	RANDOM RIPRAP, CLASS 3	CU YD	18		18	
E		2554.511	INSTALL TRAFFIC BARRIER, DESIGN 8330	LIN FT	1,468		1,468	
F	(1)	0557.603	INSTALL FENCE	LIN FT	4,780		4,780	
		0563.601	TRAFFIC CONTROL, DETOUR	LUMP SUM	1		1	
		0563.603	TRAFFIC CONTROL, SPECIAL	EACH	5		5	
	(7)	2573.501	BALE CHECK	EACH	130		130	
M	(7)	2573.503	SILT FENCE, PREASSEMBLED	LIN FT	7,965		7,965	
		2575.501	SEEDING	ACRE	16.5(P)		16.5(P)	
		2575.502	SEED MIXTURE 650	POUND	800		800	
		2575.502	SEED MIXTURE 700	POUND	228		228	
C		2575.505	SODDING, TYPE LAWN AND BOULEVARD	SQ YD	8,005		8,005	
		2575.511	MULCH MATERIAL, TYPE 1	TON	13		13	
		2575.511	MULCH MATERIAL, TYPE 5	TON	10		10	
		2575.519	DISK ANCHORING	ACRE	6.5(P)		6.5(P)	
H	(6)	2575.523	WOOD FIBER BLANKET, TYPE REGULAR	SQ YD	858		858	
		2575.531	COMMERCIAL FERTILIZER, ANALYSIS 10-10-10	TON	4.6		4.6	
	(5)	2580.501	TEMPORARY LANE MARKING	RD STA	370		370	

STANDARD PLATES  
THESE STANDARD PLATES AS APPROVED BY THE FHWA SHALL APPLY

PLATE NO.	DESCRIPTION
0005 A	SPECIFICATION REFERENCE TO STANDARD PLATES
3000 L	REINFORCED CONCRETE PIPE
3006 F	GASKET JOINT FOR R.C. PIPE
3007 B	SHEAR REINFORCEMENT FOR PRECAST DRAINAGE STRUCTURE
3040 F	CORRUGATED METAL PIPE CULVERT
3100 G	CONCRETE APRON FOR REINFORCED CONCRETE PIPE
3128 F	SAFETY APRON
3133 B	RIPRAP AT RCP OUTLETS
3145 E	CONCRETE PIPE TIES
3148 A	SAFETY SLOPE METAL END SECTIONS FOR PIPES
3221 C	CORRUGATED STEEL PIPE COUPLING BAND
4011 D	PRECAST CONCRETE BASE
4020 F	MANHOLE OR CATCH BASIN (DESIGN 60-4020)
4101 C	RING CASTING FOR MANHOLE OR CATCH BASIN
4110 E	COVER CASTING FOR MANHOLE
4180 H	MANHOLE OR CATCH BASIN STEP
8000 I	STANDARD BARRICADES
8330 D	3 CABLE GUARDRAIL
9000 B	APPROACHES AND ENTRANCES
9102 D	TURF ESTABLISHMENT AREAS (FOR PIPE CULVERT ENDS)

BASIS OF PLANNED QUANTITIES

2340	TYPE 41 PLANT MIXED WEARING COURSE MIXTURE / 110 LBS./SQ.YD. PER 1" THICKNESS BITUMINOUS MIXTURE DESIGNATION: 41WEA50055Y
2340	TYPE 41 PLANT MIXED BINDER COURSE MIXTURE / 110 LBS./SQ.YD. PER 1" THICKNESS BITUMINOUS MIXTURE DESIGNATION: 41BIB50055Y
2340	TYPE 31 PLANT MIXED BASE COURSE MIXTURE / 110 LBS./SQ.YD. PER 1" THICKNESS BITUMINOUS MIXTURE DESIGNATION: 31BBB50000Y
2357	BITUMINOUS MATERIAL FOR TACK / 0.05 GALLONS/SQ.YD.
2575	MULCH MATERIAL TYPE 1 / 2 TONS/ACRE
2575	MULCH MATERIAL TYPE 5 / 2000 LBS./ACRE
2575	COMMERCIAL FERTILIZER, ANALYSIS 10-10-10 / 500 LBS./ACRE ON ALL SEED AREAS
2575	SEEDING, BASED ON HORIZONTAL MEASUREMENT + 10%
2575	SEED MIXTURE NO. 650 / 80 LBS./ACRE
2575	SEED MIXTURE NO. 700 / 35 LBS./ACRE

INDEX OF TABULATION CHARTS

CHART	SHEET NO.	DESCRIPTION
A	3	CLEARING AND GRUBBING
B	3	DRIVEWAY CONSTRUCTION CHART
C	3	SODDING
D	3	BITUMINOUS REMOVAL
E	3	MISCELLANEOUS SALVAGE/REMOVAL
F	3	SALVAGE AND INSTALL FENCE
G	3	SAVING BITUMINOUS PAVEMENT
H	4	CULVERT TABULATION
I	4	STORM SEWER
J	4	DRAINAGE CASTING SCHEDULE
K	5	PRIVATE UTILITIES
L	5	BITUMINOUS AND AGGREGATE BASE SUMMARY
M	5	SILT FENCE
N	6	EARTHWORK SUMMARY
	40	DETOUR SIGNING
	41	TEMPORARY LANE CLOSURES

NOTES:

- (1) INCLUDES ALL SIZES AND TYPES.
- (2) INCLUDES ALL BITUMINOUS PAVEMENTS REGARDLESS OF DEPTH AND WIDTH.
- (3) FOR DUST CONTROL AS DIRECTED BY THE ENGINEER.
- (4) FOR DRIVEWAY PAVEMENTS.
- (5) QUANTITY SHOWN PROVIDES FOR FOUR APPLICATIONS OF LANE MARKINGS.
- (6) FOR USE AT CULVERT ENDS.
- (7) FOR TEMPORARY EROSION CONTROL AS DIRECTED BY THE ENGINEER.
- (8) INCLUDES QUANTITY FOR AGGREGATE APPROACHES AND ENTRANCES.
- (9) (OMITTED).
- (10) EXCAVATION FOR POWER POLE RELOCATION IN MUCK AREAS.
- (11) INCLUDES QUANTITY FOR ADDING 1/4" TO THE DESIGN THICKNESS.
- (12) INCLUDES ADJUST ON STRUCTURES 2 AND 4 TO ACCOMMODATE FINAL WEAR COURSE.
- (13) (OMITTED).
- (14) (OMITTED).

ESTIMATED QUANTITIES

REVISIONS  
DATE BY



CLEARING AND GRUBBING (A)					
STATION - STATION	LOCATION	CLEARING		GRUBBING	
		TREE	ACRE	TREE	ACRE
201+15	45' LT	1		1	
201+28	45' LT	1		1	
201+35	56' LT	1		1	
201+41	45' LT	1		1	
201+48	56' LT	1		1	
201+78	45' LT	1		1	
202+00	46' LT	1		1	
202+20	45' LT	1		1	
202+54	54' LT	1		1	
208+31	47' LT	1		1	
208+32	55' LT	1		1	
208+39	48' LT	1		1	
208+69	47' LT	1		1	
209+74	44' RT	1		1	
215+77 - 225+16	32' - 65' RT		1.05		1.05
218+55 - 219+72	36' - 70' LT		0.15		0.15
219+66	69' LT	1		1	
219+77	69' LT	1		1	
219+81	50' LT	1		1	
219+98	39' LT	1		1	
220+15	44' LT	1		1	
220+22	46' LT	1		1	
220+23	36' LT	1		1	
220+28	35' LT	1		1	
220+33	35' LT	1		1	
220+34	48' LT	1		1	
220+36	39' LT	1		1	
220+56 - 221+35	30' - 49' LT		0.1		0.1
222+65	43' LT	1		1	
222+70	43' LT	1		1	
227+25	59' LT	1		1	
229+37 - 229+79	55' - 60' LT		0.05		0.05
237+81	48' LT	1		1	
237+83	49' LT	1		1	
238+01	43' LT	1		1	
238+16	38' LT	1		1	
238+18	53' LT	1		1	
238+23	39' LT	1		1	
239+25	36' LT	1		1	
239+30	44' LT	1		1	
239+41	38' LT	1		1	
239+46	62' LT	1		1	
239+57	62' LT	1		1	
239+60	57' LT	1		1	
246+43	40' RT	2		1	
246+51	40' RT	1		1	
266+93	49' RT	1		1	
267+00	48' RT	1		1	
267+05	47' RT	1		1	
276+57	37' RT	1		1	
276+85	37' RT	1		1	
277+23	40' RT	1		1	
277+29	44' RT	1		1	
277+97	42' RT	1		1	
277+97	46' RT	1		1	
277+97	52' RT	1		1	
277+97	54' RT	1		1	
TOTALS		51	1.35	53	1.35

DRIVEWAY CONSTRUCTION CHART (B)															
STATION/LOC.	ADDRESS	REMARKS	EXIST WIDTH	REMOVE		CONCRETE DRIVEWAY PAVEMENT				BIT. PAVEMENT		AGGREGATE ENTRANCE			
				CONC. SQ. YD.	BIT. SQ. YD.	APRON SQ. YD.	DRIVEWAY SQ. YD.	DRIVEWAY SQ. YD.	DRIVEWAY SQ. YD.	DRIVEWAY SQ. YD.	WIDTH	REPLMT.	NEW	WIDTH	CU. YD.
202+45/LT	4351	RESIDENTIAL ENTRANCE	11		77						14	67			
204+65/RT		FIELD ENTRANCE	14								14		51	14	3
209+46/LT	4501	RESIDENTIAL ENTRANCE	14								14		51	14	3
217+86/RT	4550	RESIDENTIAL ENTRANCE	14								14		43	14	3
220+47/LT	4601	RESIDENTIAL ENTRANCE	11		69						14	64	64		
221+42/RT	4800	RESIDENTIAL ENTRANCE	12								14		44	14	3
224+45/LT	4811	RESIDENTIAL ENTRANCE	14		77						14	76			
224+70/RT			12								12		46	12	2
225+32/RT			14								14		49		
226+28/RT	4851	RESIDENTIAL ENTRANCE									12		49		
226+84/LT	4919	RESIDENTIAL ENTRANCE	21								21		67	21	4
228+58/LT		FIELD ENTRANCE	18								18		51	18	2
228+90/LT		FIELD ENTRANCE	18								18		51	18	2
235+02/LT		FIELD ENTRANCE	15								15		55		
235+10/RT		FIELD ENTRANCE	14								14		51	14	2
236+40/LT		FIELD ENTRANCE	28								28		82	28	2
243+75/LT		FIELD ENTRANCE	29								29		111	29	3
248+45/RT		FIELD ENTRANCE	22								22		92	22	3
248+50/LT		FIELD ENTRANCE	42								32		119	32	5
255+84/LT		COMMERCIAL ENTRANCE	NEW								32		119	32	5
257+56/LT		RELOCATE TO 257+80/LT	50								32		119	32	5
267+77/RT		FIELD ENTRANCE	30								30		120	30	4
267+81/LT		FIELD ENTRANCE	22								22		91	22	3
268+48/RT		FIELD ENTRANCE	20								20		86	20	3
276+04/RT		COMMERCIAL ENTRANCE	79								32		119	32	4
276+27/LT		FIELD ENTRANCE	40								32		119		
277+63/RT	310	RESIDENTIAL ENTRANCE	18								18		81	18	3
279+58/RT		COMMERCIAL ENTRANCE	22								22		92		
282+32/LT		COMMERCIAL ENTRANCE	24								24		98	24	4
285+18/RT	350	RESIDENTIAL ENTRANCE	12		89						12	65			
286+23/RT	332	RESIDENTIAL ENTRANCE	10		46						12	43			
290+92/LT		FIELD ENTRANCE	33								32		91	32	6
248+85/LT		DRAINAGE DITCH CROSSING	28											24	4
274+65/LT		DRAINAGE DITCH CROSSING	24											24	4
TOTALS					358						315	2211			82

Ⓛ PAID FOR AS 2" THICK WEARING COURSE PLACED

BITUMINOUS REMOVAL (D)			
STATION - STATION	LOCATION	DESCRIPTION	SQ. YDS.
199+67 - 292+25	LT./RT.	C.S.A.H. NO. 14	24772
202+45	LT.	RESIDENTIAL ENTRANCE	77
220+47	LT.	RESIDENTIAL ENTRANCE	69
224+45	LT.	RESIDENTIAL ENTRANCE	77
241+81	RT.	COUNTY ROAD NO. 53	257
285+18	RT.	RESIDENTIAL ENTRANCE	89
286+23	RT.	RESIDENTIAL ENTRANCE	46
TOTAL			25387

MISCELLANEOUS SALVAGE/REMOVAL (E)				
ITEM	DESCRIPTION	STA/LOC	LIN. FT.	SQ. YDS.
2104.505	REMOVE RIPRAP	291+41/26' LT		26
2104.505	REMOVE CONC. PAVE.	276+73/31' LT		10
*2104.521	SALVAGE GUARD RAIL	249+00-257+00/15' LT	800	
*2104.521	SALVAGE GUARD RAIL	258+12-264+80/15' LT	668	
TOTALS			1468	

\* SALVAGED GUARDRAIL TO BE INSTALLED ON CSAH 17 APPROXIMATELY 1.5 MILES NORTH OF CSAH 14 AS DIRECTED BY THE ENGINEER.

SODDING (C)			
STATION - STATION	LOCATION	SQ. YDS.	REMARKS
201+08 - 202+70	LT	550	
208+25 - 209+42	LT	851	
219+57 - 222+26	LT	1968	
222+26 - 225+52	LT	1514	
225+52 - 227+29	LT	815	
276+20 - 278+20	RT	783	
284+90 - 287+27	RT	788	
291+08 - 292+25	LT	408	
291+26 - 292+25	RT	328	
TOTAL		8005	

SALVAGE & INSTALL FENCE (F)				
STATION - STATION	LOC	DESCRIPTION	SALVAGE LIN. FT.	INSTALL LIN. FT.
199+67 - 215+69	RT	BARBED WIRE	1622	1602
222+23 - 225+50	LT	BARBED WIRE	340	340
227+28 - 235+17	LT	BARBED WIRE	857	817
228+77 - 241+40	RT	BARBED WIRE	1303	1257
281+45 - 285+02	RT	BARBED WIRE	381	339
282+10 - 282+52	LT	STOCK FENCE-GATE	42	42
287+92 - 290+94	LT	BARBED WIRE	331	313
257+13 - 257+82	LT	GATE	70	70
TOTAL			4946	4780

SAWING BITUMINOUS PAVEMENT (C)		
STATION - STATION	LOCATION	LIN. FT.
199+67	C/L	48
202+45	LT	11
220+47	LT	11
224+45	LT	16
241+81	RT	24
285+18	RT	12
286+23	RT	10
292+25	C/L	48
TOTAL		180

TABULATION CHARTS  
 CLEARING AND GRUBBING, DRIVEWAY CONSTRUCTION, SODDING,  
 BITUMINOUS REMOVAL, MISCELLANEOUS SALVAGE/REMOVAL,  
 SALVAGE & INSTALL FENCE, SAWING BITUMINOUS PAVEMENT

REVISIONS	DATE	BY











EARTHWORK SUMMARY (N)

C.S.A.H. 14, STATION 199+67 TO STATION 292+25

EXCAVATION:

COMMON:	23,458 CU. YDS.	[ REGULAR: 14,382 CU. YDS. (1) TOPSOIL: 3,012 CU. YDS. SUBCUT: 6,064 CU. YDS.             ]
MUCK:	124,392 CU. YDS. (2)	
MUCK(SPECIAL):	7,390 CU. YDS. (3)	

(1) INCLUDES 1,829 CU. YDS. BITUMINOUS REMOVAL.  
 (2) INCLUDES 2,362 CU. YDS. BITUMINOUS REMOVAL.  
 (3) FOR POWER POLE FOUNDATION.

EMBANKMENT: (CV)

REGULAR FILL: 10,831 CU. YDS.  
 CORE REPLACEMENT: 114,074 CU. YDS.  
 MUCK FILL: 11,056 CU. YDS.  
 TOPSOIL DRESSING: 2,561 CU. YDS.

BALANCE:

TOPSOIL:  
 TOPSOIL DRESSING (CV) - [TOPSOIL STRIPPING (EV) x SHRINKAGE FACTOR] = EXCESS(-) OR SHORTAGE(+)  
 $2,561 - (3,012 \times 0.85) = 0$  (TOPSOIL BALANCES)

MUCK:  
 MUCK FILL (CV) - [MUCK EXCAVATION (EV) x SHRINKAGE FACTOR] = EXCESS(-) OR SHORTAGE(+)  
 $11,056 - [(124,392 + 7,370 - 2,362) \times 0.60] = -66,584$  (EXCESS)

GRANULAR:  
 REGULAR FILL (CV) + CORE REPLACEMENT (CV) - [REGULAR EXCAVATION (EV) x SHRINKAGE FACTOR] -  
 [SUBCUT EXCAVATION x SHRINKAGE FACTOR] = EXCESS(-) OR SHORTAGE(+)  
 $10,831 + 114,074 - [(14,382 - 1,829) \times 0.85] - (6,064 \times 0.90) = +108,777$  (SHORTAGE)(CV)  
 \* GRANULAR BORROW = (CV) x SWELL FACTOR =  $108,777 \times 1.2 = 130,532$  (LV)

SOIL FACTORS:

- (1) REGULAR GRADING AND TOPSOIL DRESSING (EV TO CV): 85% SHRINKAGE
- (2) SUBCUT COMPACTION (EV TO CV): 90% SHRINKAGE
- (3) MUCK EXCAVATION/COMPACTION (EV TO CV): 60% SHRINKAGE
- (4) GRANULAR BORROW (CV TO EV): 120% SWELL

SOILS AND CONSTRUCTION NOTES

1. TOP OF GRADING SUBGRADE IS DEFINED AS THE BOTTOM OF THE AGGREGATE BASE.
2. IN FILL AREAS, THE SUBGRADE SHALL BE CONSTRUCTED WITH SELECT GRADING MATERIAL.
3. SELECTED GRADING MATERIALS SHALL CONSIST OF GRANULAR MATERIALS.
4. GRANULAR MATERIAL, REGARDLESS OF SOURCE, SHALL MEET THE REQUIREMENTS OF SPEC. 3149.2A
5. COMPACTION OF THE GRADING PORTION OF THIS PROJECT SHALL BE BY THE "ORDINARY COMPACTION METHOD" WITH THE EXCEPTION OF THE CULVERT TRENCHES WHICH SHALL BE COMPACTED BY THE "SPECIFIED DENSITY METHOD".
6. TEST ROLLING WILL NOT BE REQUIRED.
7. BITUMINOUS AND/OR CONCRETE ITEMS REMOVED BY CONSTRUCTION SHALL BECOME THE PROPERTY OF THE CONTRACTOR AND SHALL EITHER BE RECYCLED OR DISPOSED OF OFF THE PROJECT LIMITS WITH NO DIRECT COMPENSATION MADE THEREFORE.
8. DISPOSITIN OF EXCAVATED MATERIAL SHALL BE IN ACCORDANCE WITH SPEC. 2105.3D WITH NO DIRECT COMPENSATION MADE THEREFORE.
9. WHERE CONNECTING NEW SURFACING TO AN INPLACE PAVEMENT, THE EXCAVATION SHALL BE BACKFILLED PROMPTLY TO AVOID UNDERMINING THE INPLACE PAVEMENT.
10. USE TACK COAT BETWEEN ALL BITUMINOUS MIXTURES PRIOR TO PLACING BITUMINOUS MIXTURES AND PRIOR TO PLACING ANY BITUMINOUS MIXTURES ON EXISTING CONCRETE OR BITUMINOUS SURFACES. THE BITUMINOUS TACK COAT MATERIAL SHALL BE APPLIED AT A UNIFORM RATE OF 0.03 TO 0.05 GALLONS PER SQUARE YARD BETWEEN BITUMINOUS LAYERS. THE APPLICATION RATES ARE FOR UNDILUTED EMULSIONS (AS SUPPLIED FROM THE REFINERY); ASPHALT EMULSION MAY BE FURTHER DILUTED IN THE FIELD IN ACCORDANCE WITH SPEC. 2357.
11. COMPACTION OF ALL BITUMINOUS COURSES SHALL BE BY THE "MODIFIED SPECIFIED DENSITY METHOD".
12. COMPACTION OF THE AGGREGATE BASE LAYERS SHALL BE BY THE "SPECIFIED DENSITY METHOD".
13. IN AREAS TO BE DISTURBED BY CONSTRUCTION, STRIP AND RE-USE AS SLOPE DRESSING ALL TOPSOIL AND INPLACE SLOPE DRESSING. REFER TO THE CROSS-SECTION FOR THE LIMITS OF TOPSOIL STRIPPING. GENERAL DEPTHS OF TOPSOIL LAYER ARE ASSUMED TO BE 0"-3".
14. SLOPE DRESSING ON THIS PROJECT IS DEFINED AS THE TOPSOIL OR OTHER SOIL PLACED DURING PRIOR CONSTRUCTION TO PROVIDE A MEDIUM FOR ESTABLISHING TURF.
15. PLACE A MINIMUM OF 3 INCHES OF TOPSOIL OR SLOPE DRESSING ON ALL AREAS DISTURBED BY CONSTRUCTION AND SCHEDULED FOR PERMANENT TURF ESTABLISHMENT. FERTILIZE WITH COMMERCIAL FERTILIZER, ANALYSIS 10-10-10, AT A RATE OF 500 POUNDS PER ACRE OR EQUIVALENT.
16. SOD ALL DISTURBED LAWNS
17. ALL SOD UTILIZED WITHIN THE PROJECT LIMITS SHALL MEET THE REQUIREMENTS OF SPEC. 3878.2A (LAWN AND BOULEVARD SOD).
18. EXCESS TOPSOIL AND MUCK EXCAVATION MAY BE USED IN EMBANKMENT CONSTRUCTION IN AREAS OUTSIDE OF A 1 1/2:1 SLOPE FROM THE GRADING SHOULDER P. I.
19. EXISTING STABILIZED SUBGRADE MUST BE PULVERIZED PRIOR TO USE AS EMBANKMENT MATERAIL.
20. EXCESS MUCK EXCAVATION TO BE DISPOSED OF BY THE CONTRACTOR OUTSIDE OF THE RIGHT-OF-WAY LIMITS WITH NO DIRECT COMPENSATION MADE THEREFORE.
21. BITUMINOUS REMOVAL QUANTITY BASED ON 6" OF BITUMINOUS SURFACING. THE CONTACTOR SHALL INVESTIGATE AND MAKE THIER OWN DETERMINATION OF ACTUAL PAVEMENT DEPTH.

REVISIONS:	DATE	BY



**NORMAL GRADING**

STATION 199+67 TO STATION 292+25

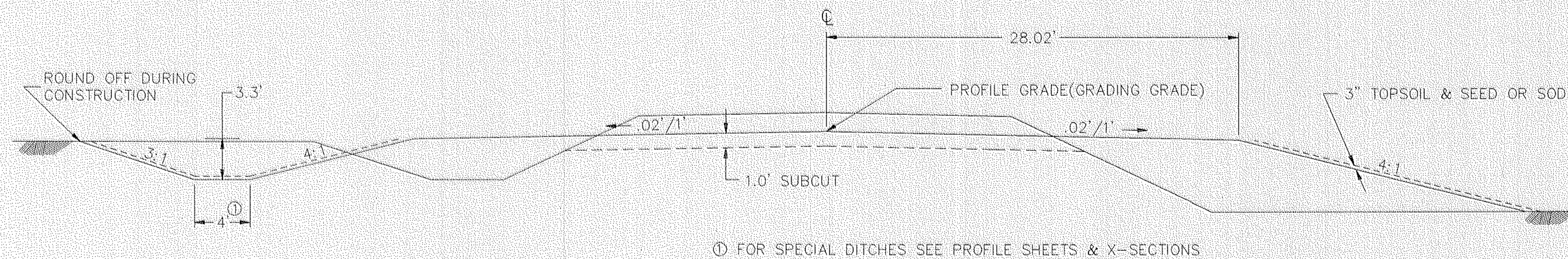

**MUCK EXCAVATION**

**DESIGN F-1**  
STATION 199+67 TO STATION 292+25

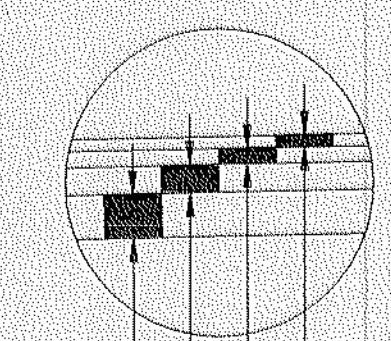
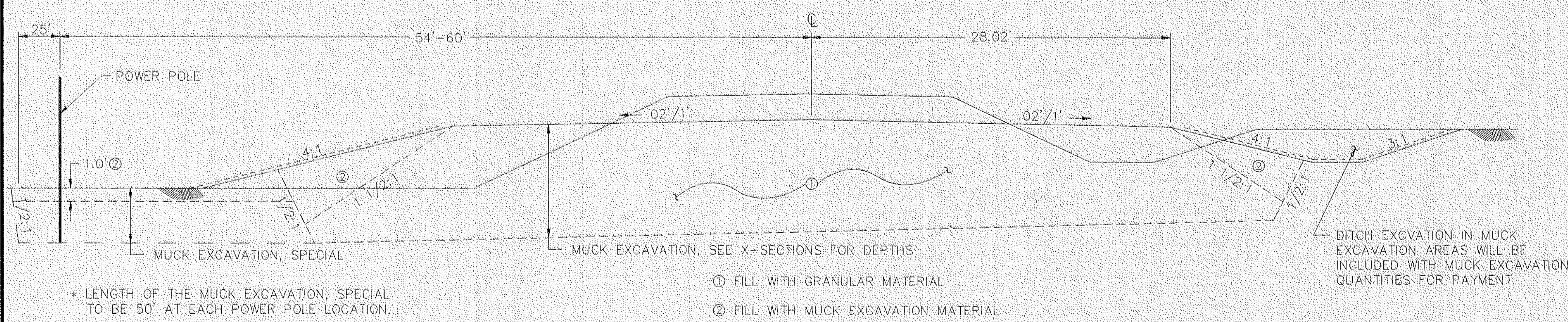

- 1 1/2" TYPE 41 WEARING COURSE-SPEC. 2340 BITUMINOUS MIXTURE DESIGNATION: 41WEA50055Y
- 1 1/2" TYPE 41 BINDER COURSE-SPEC. 2340 BITUMINOUS MIXTURE DESIGNATION: 41BIB50055Y
- 3" TYPE 31 BASE COURSE-SPEC. 2340 BITUMINOUS MIXTURE DESIGNATION: 31BBB50000Y
- 4" AGGREGATE BASE CL-5-SPEC. 2211 TACK COAT-SPEC. 2357, TO BE APPLIED BETWEEN ALL BITUMINOUS LIFTS.

\* LENGTH OF THE MUCK EXCAVATION, SPECIAL TO BE 50' AT EACH POWER POLE LOCATION.  
\* POWER POLE LOCATIONS TO BE DETERMINED IN THE FIELD BY THE ENGINEER.  
*All utility poles and other unyielding objects will be removed and relocated outside the Recovery Area.*

**DESIGN F-2**

STATION 199+67 TO STATION 292+25  
(ALSO TO BE USED @ STREET APPROACHES)

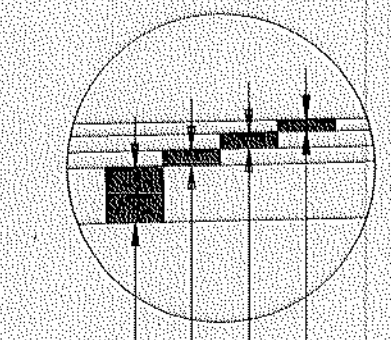

- 1 1/2" TYPE 41 WEARING COURSE-SPEC. 2340 BITUMINOUS MIXTURE DESIGNATION: 41WEA50055Y
- 1 1/2" TYPE 41 BINDER COURSE-SPEC. 2340 BITUMINOUS MIXTURE DESIGNATION: 41BIB50055Y
- 1 1/2" TYPE 31 BASE COURSE-SPEC. 2340 BITUMINOUS MIXTURE DESIGNATION: 31BBB50000Y
- 5 1/2" AGGREGATE BASE CL-5-SPEC. 2211 TACK COAT-SPEC. 2357, TO BE APPLIED BETWEEN ALL BITUMINOUS LIFTS.

**RURAL TYPICAL SECTION**

STATION 199+67 TO STATION 292+25

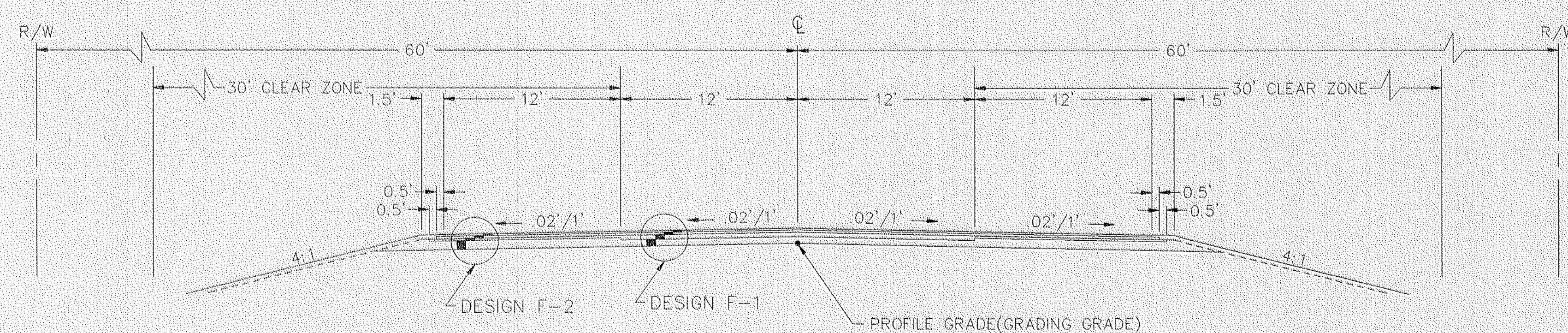

TYPICAL SECTIONS

REVISIONS	DATE	BY



STA. 201+00 C/L CULVERT  
F&I. 24" x 72" R.C.P. CULVERT  
F&I. 2 - 24" R.C.P. APRONS  
INVERT ELEV. LT. = 900.40  
INVERT ELEV. RT. = 900.70

STA. 202+45 LT.  
INPL. 15" x 30' C.M.P.  
REMOVE  
F&I. 15" x 46' C.M.P. CULVERT  
F&I. 2 - 15" C.M.P. APRONS

STA. 203+57 C/L CULVERT  
INPL. 18" x 56' C.M.P.  
REMOVE  
NO CULVERT REQUIRED

STA. 209+46 LT.  
INPL. 48" x 28' C.M.P.  
REMOVE  
F&I. 18" x 42' C.M.P. CULVERT  
F&I. 2 - 18" C.M.P. APRONS

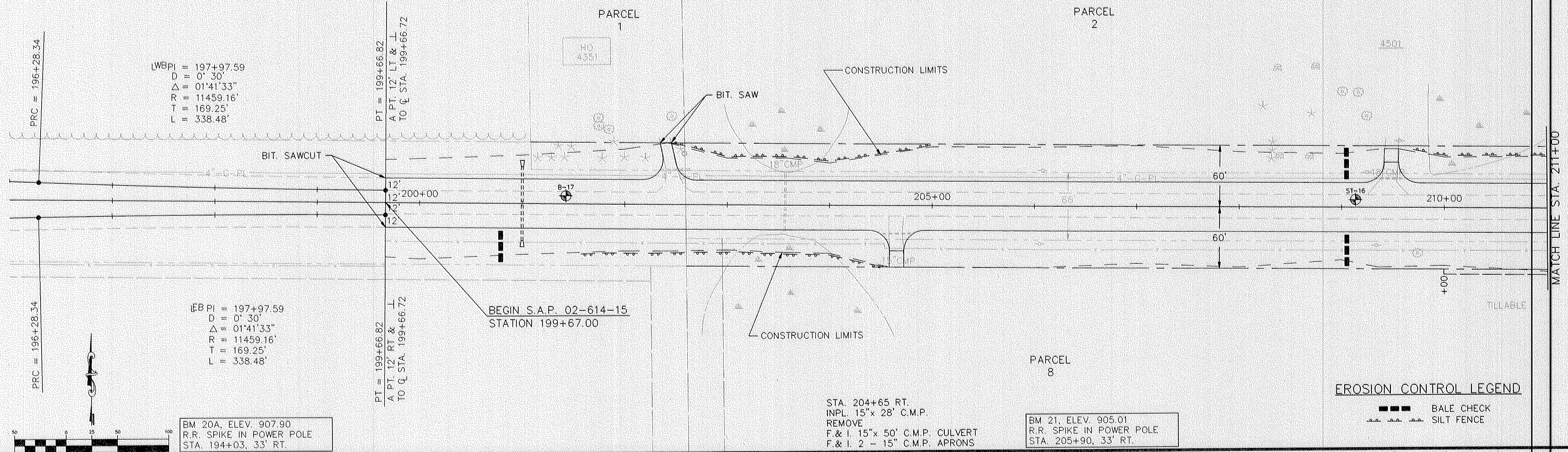

LWBPI = 197+97.59  
D = 0' 30"  
Δ = 01°41'33"  
R = 11459.16'  
T = 169.25'  
L = 338.48'

EBPI = 197+97.59  
D = 0' 30"  
Δ = 01°41'33"  
R = 11459.16'  
T = 169.25'  
L = 338.48'

BM 20A, ELEV. 907.90  
R.R. SPIKE IN POWER POLE  
STA. 194+03, 33' RT.

BM 21, ELEV. 905.01  
R.R. SPIKE IN POWER POLE  
STA. 205+90, 33' RT.

**EROSION CONTROL LEGEND**

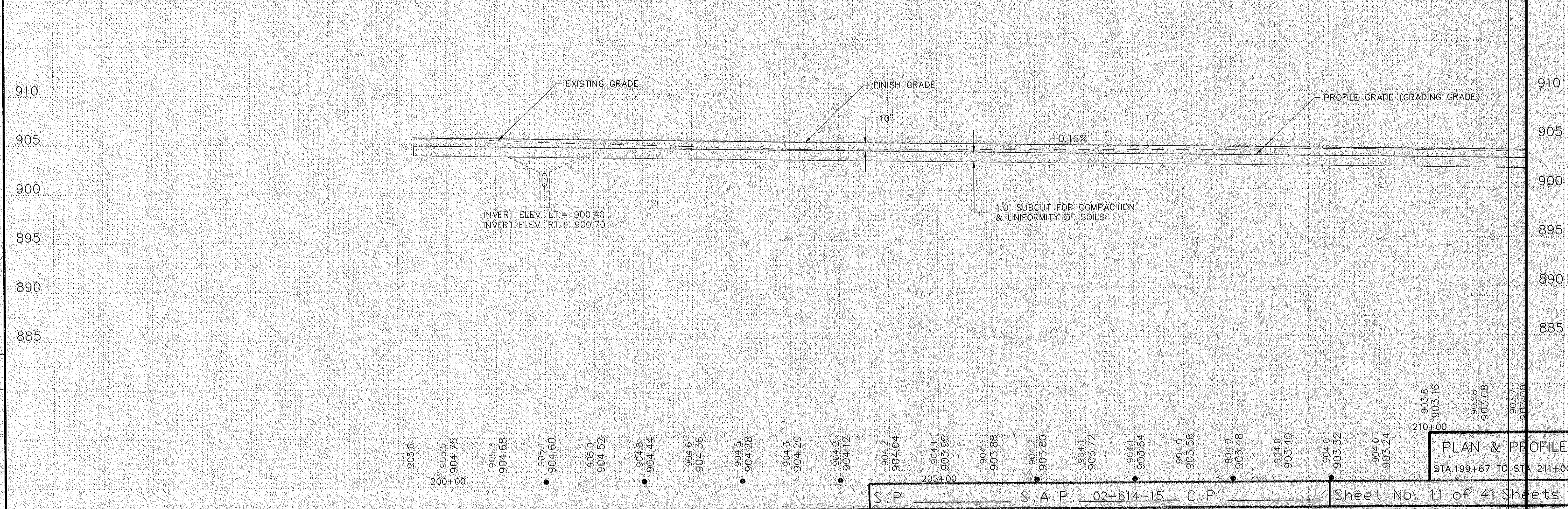

905.6  
905.5  
904.76  
905.3  
904.68  
905.1  
904.60  
905.0  
904.52  
904.9  
904.44  
904.6  
904.36  
904.5  
904.28  
904.3  
904.20  
904.2  
904.12  
904.2  
904.04  
904.1  
903.96  
904.1  
903.88  
904.2  
903.80  
904.1  
903.72  
904.1  
903.64  
904.0  
903.56  
904.0  
903.48  
904.0  
903.40  
904.0  
903.32  
904.0  
903.24  
903.8  
903.16  
903.8  
903.08  
903.7  
903.00

REVISIONS	DATE	BY

14VIEW.DWG (TITLEMODE) MN.



**EROSION CONTROL LEGEND**

- ▬▬▬ BALE CHECK
- ▬▬▬ SILT FENCE

STA. 215+73 LT.  
 INPL. 18" x 48' C.M.P.  
 REMOVE  
 F. & I. 18" x 56' C.M.P. CULVERT  
 F. & I. 2 - 18" C.M.P. APRONS

STA. 220+47 LT.  
 INPL. 15" x 30' C.M.P.  
 REMOVE  
 F. & I. 18" x 56' C.M.P. CULVERT  
 F. & I. 2 - 18" C.M.P. APRONS

STA. 224+45 LT.  
 INPL. 18" x 30' C.M.P.  
 REMOVE  
 F. & I. 18" x 48' C.M.P. CULVERT  
 F. & I. 2 - 18" C.M.P. APRONS

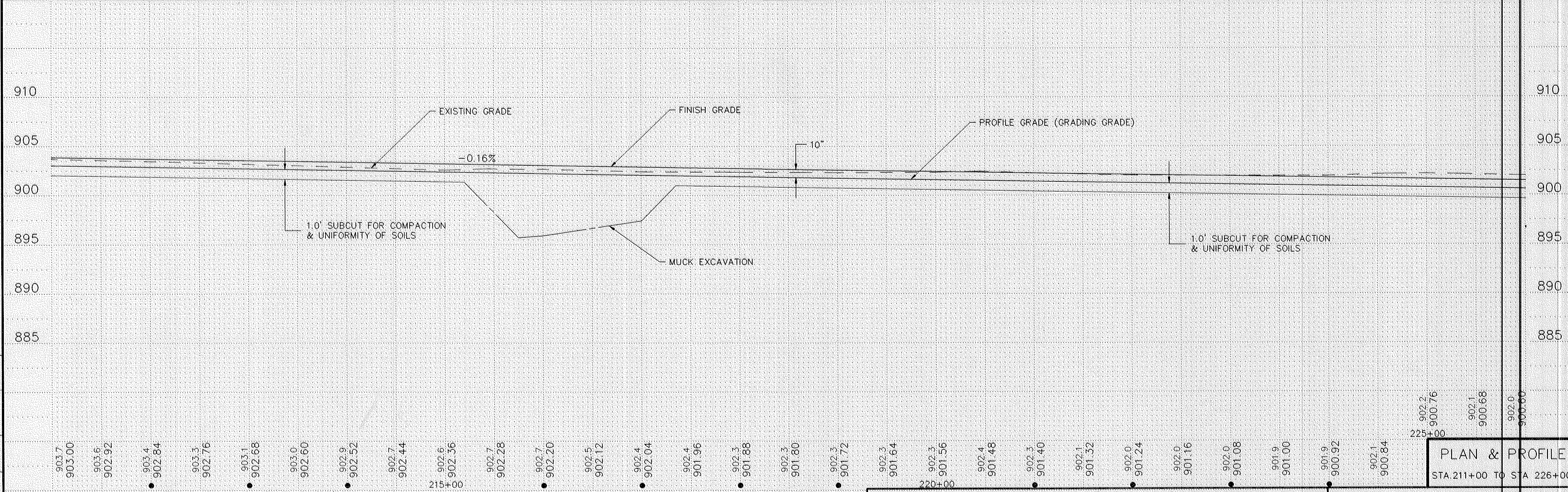
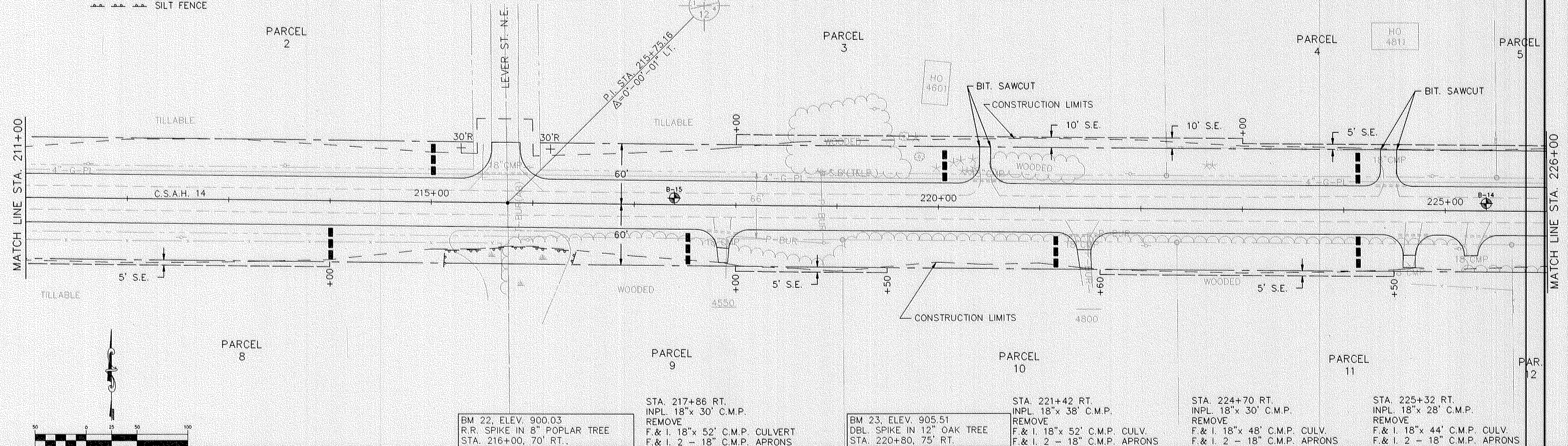

REVISIONS	DATE	BY

**PLAN & PROFILE**  
 STA 211+00 TO STA 226+00



STA. 226+84 LT.  
INPL. 18" x 40' C.M.P.  
REMOVE  
F. & I. 18" x 60' C.M.P. CULVERT  
F. & I. 2 - 18" C.M.P. APRONS

STA. 228+58/228+90 LT.  
INPL. 18" x 28' / 24" x 32' C.M.P.  
REMOVE  
F. & I. 24" x 84' C.M.P. CULVERT  
F. & I. 2 - 24" C.M.P. APRONS

STA. 230+16 C/L CULVERT  
INPL. 24" x 44' C.M.P.  
REMOVE  
F. & I. 24" x 80' R.C.P. CULVERT  
F. & I. 2 - 24" R.C.P. APRONS  
INVERT ELEV. LT.(+30) = 895.90  
INVERT ELEV. RT.(+00) = 895.40

STA. 235+02 LT.  
INPL. 18" x 30' C.M.P.  
REMOVE  
NO CULVERT REQUIRED

STA. 236+40 LT.  
INPL. 18" x 32' C.M.P.  
REMOVE  
F. & I. 18" x 46' C.M.P. CULVERT  
F. & I. 2 - 18" C.M.P. APRONS

$\Delta = 02^{\circ}56'24''$   
 $R = 22918.31'$   
 $T = 588.13'$   
 $L = 1176.00'$   
 $D = 0^{\circ}-15'$

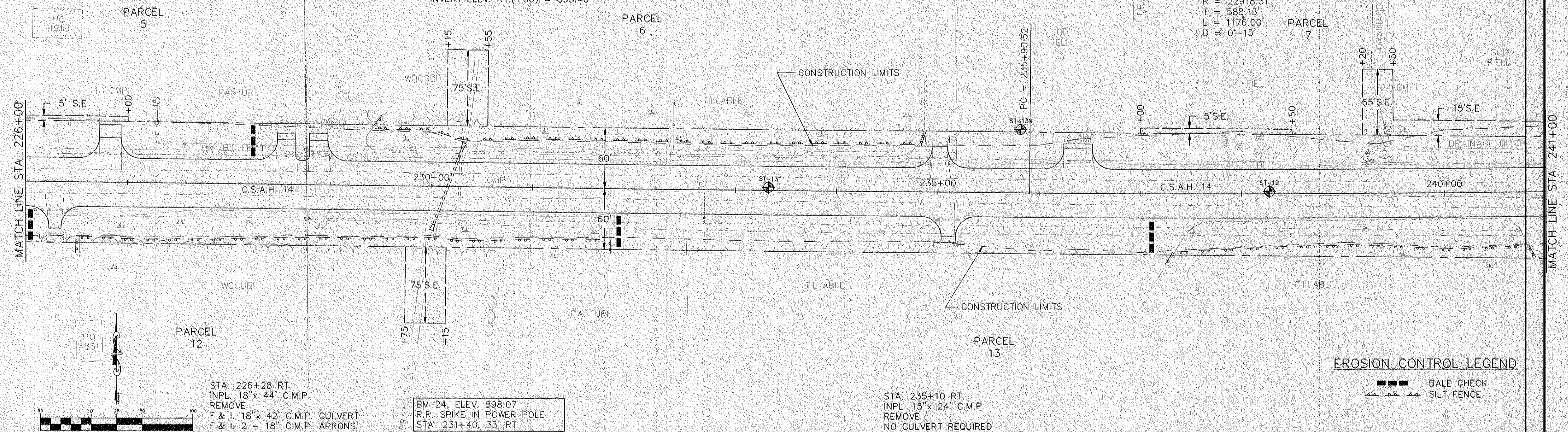

**EROSION CONTROL LEGEND**

- ■ ■ ■ ■ BALE CHECK
- ▲ ▲ ▲ ▲ ▲ SILT FENCE

STA. 226+28 RT.  
INPL. 18" x 44' C.M.P.  
REMOVE  
F. & I. 18" x 42' C.M.P. CULVERT  
F. & I. 2 - 18" C.M.P. APRONS

BM 24, ELEV. 898.07  
R.R. SPIKE IN POWER POLE  
STA. 231+40, 33' RT.

STA. 235+10 RT.  
INPL. 15" x 24' C.M.P.  
REMOVE  
NO CULVERT REQUIRED

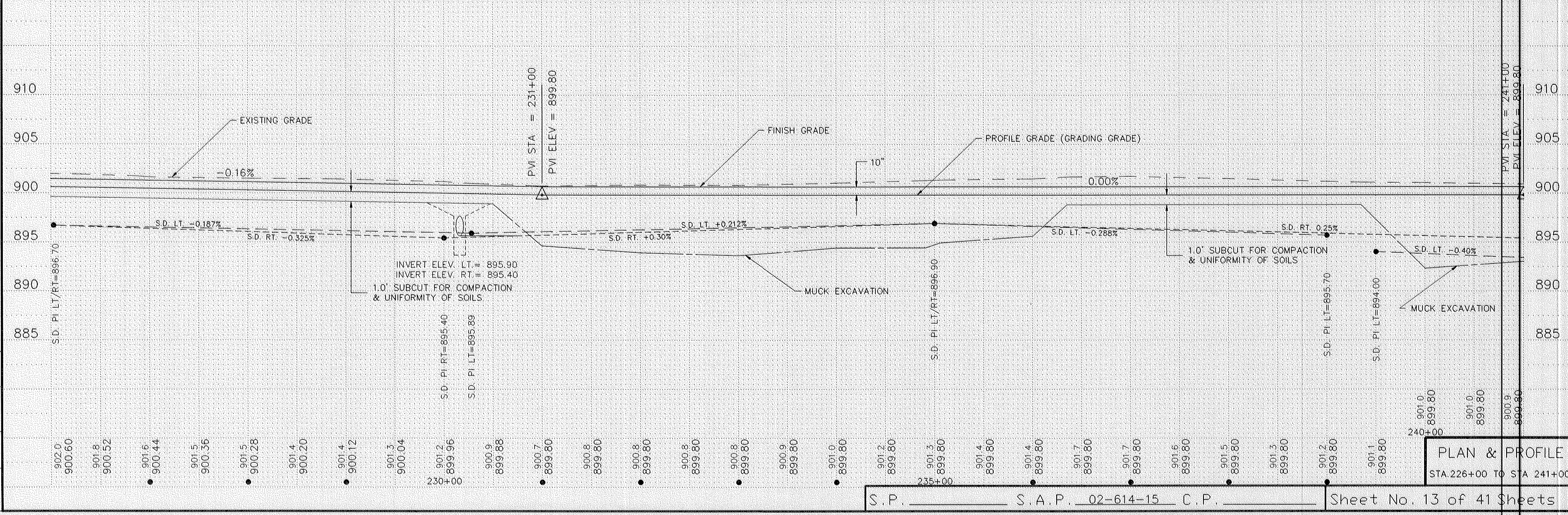

REVISIONS	DATE	BY

**PLAN & PROFILE**  
STA. 226+00 TO STA. 241+00



STA. 243+75 LT.  
INPL. 30"x 44' C.M.P.  
REMOVE  
F. & I. 30"x 54' C.M.P. CULVERT  
F. & I. 2 - 30" C.M.P. APRONS

STA. 245+40 LT.  
INPL. 15"x 34' R.C.P.  
REMOVE  
ELIMINATE FIELD X-ING

STA. 248+50 LT.  
INPL. 30"x 56' C.M.P.  
REMOVE  
F. & I. 30"x 70' C.M.P. CULVERT  
F. & I. 2 - 30" C.M.P. APRONS

STA. 248+85 LT.  
INPL. 30"x 42' C.M.P.  
REMOVE  
F. & I. 30"x 46' C.M.P. CULVERT  
F. & I. 2 - 30" C.M.P. APRONS

STA. 249+80 C/L CULVERT  
INPL. 18"x 52' R.C.P.  
REMOVE  
NO CULVERT REQUIRED

STA. 255+05 LT.  
INPL. 18" C.M.P.  
LEAVE AS IS

STA. 255+84 LT.  
NO CULVERT INPLACE  
CONSTRUCT NEW ENTRANCE  
F. & I. 30"x 60' C.M.P. CULVERT  
F. & I. 2 - 30" C.M.P. APRONS

$\Delta = 02^{\circ}56'24"$   
 $R = 22918.31'$   
 $T = 588.13'$   
 $L = 1176.00'$   
 $D = 0'-15'$

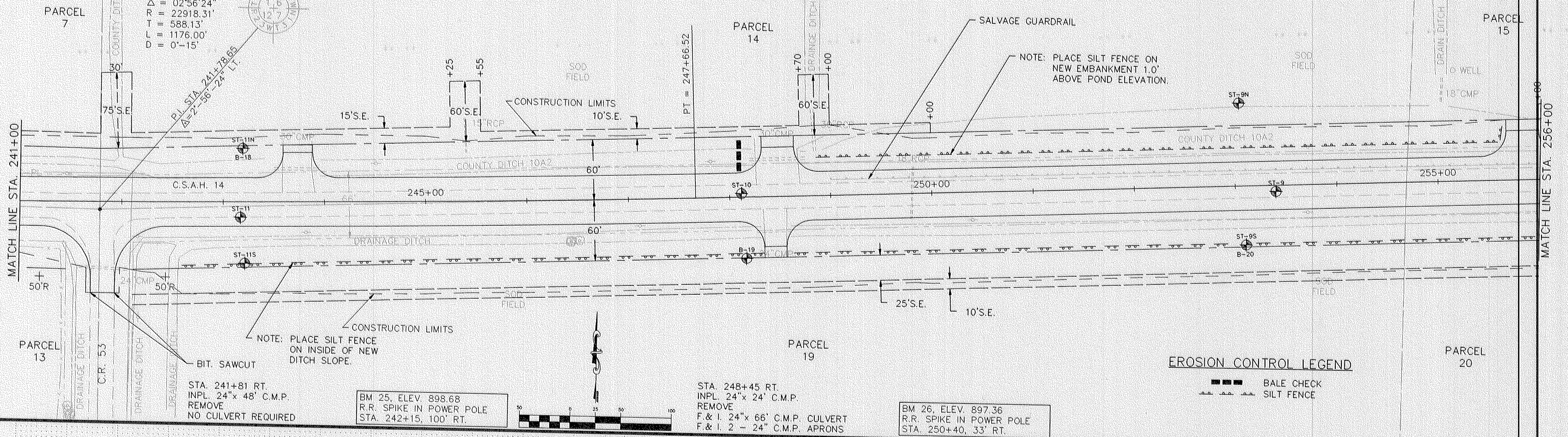
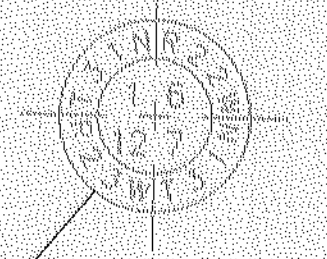

**EROSION CONTROL LEGEND**  
 BALE CHECK  
 SILT FENCE

BM 25, ELEV. 898.68  
R.R. SPIKE IN POWER POLE  
STA. 242+15, 100' RT.

STA. 248+45 RT.  
INPL. 24"x 24' C.M.P.  
REMOVE  
F. & I. 24"x 66' C.M.P. CULVERT  
F. & I. 2 - 24" C.M.P. APRONS

BM 26, ELEV. 897.36  
R.R. SPIKE IN POWER POLE  
STA. 250+40, 33' RT.

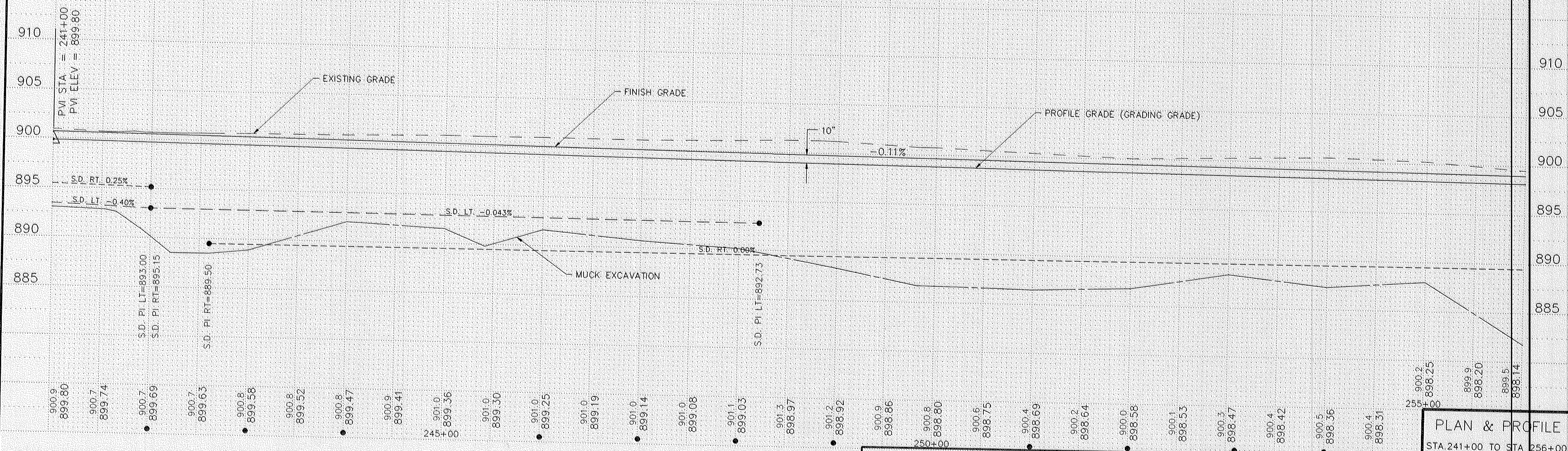
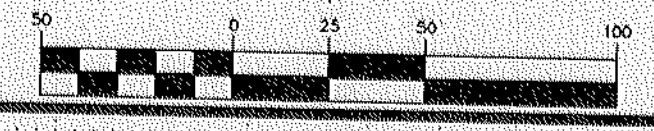

REVISIONS	DATE	BY

**PLAN & PROFILE**  
STA. 241+00 TO STA. 256+00







STA. 274+65 LT.  
INPL. 24"x 30" C.M.P.  
REMOVE  
F.&I. 24"x 34" C.M.P. CULVERT  
F.&I. 2 - 24" C.M.P. APRONS

STA. 276+27 LT.  
NO CULVERT INPLACE  
NO CULVERT REQUIRED

STA. 281+22 C/L CULVERT  
INPL. 24"x 46" R.C.P.  
REMOVE  
F.&I. 24"x 84" R.C.P. CULVERT  
F.&I. 2 - 24" R.C.P. APRONS  
INVERT ELEV. LT. = 895.55  
INVERT ELEV. RT. = 895.25

STA. 282+32 LT.  
INPL. 36"x 40" C.M.P.  
REMOVE  
F.&I. 36"x 54" C.M.P. CULVERT  
F.&I. 2 - 36" C.M.P. APRONS

BM 30, ELEV. 901.52  
S.W. COR. CONCRETE WALK  
GOLF DRIVING RANGE, 150' LT.

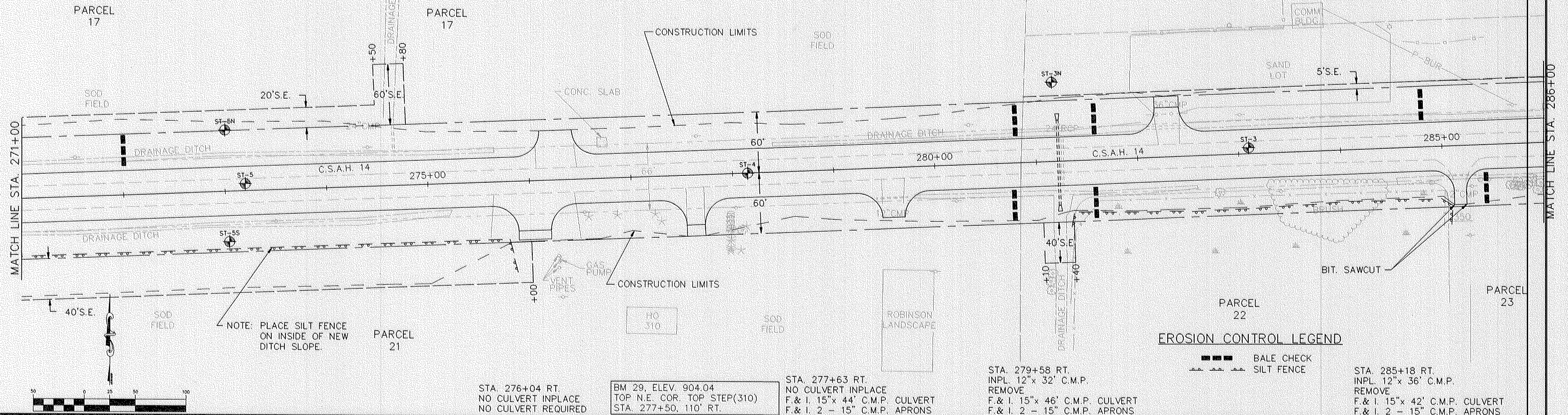

**EROSION CONTROL LEGEND**

- BALE CHECK
- ▲ SILT FENCE

STA. 276+04 RT.  
NO CULVERT INPLACE  
NO CULVERT REQUIRED

BM 29, ELEV. 904.04  
TOP N.E. COR. TOP STEP(310)  
STA. 277+50, 110' RT.

STA. 277+63 RT.  
NO CULVERT INPLACE  
F.&I. 15"x 44" C.M.P. CULVERT  
F.&I. 2 - 15" C.M.P. APRONS

STA. 279+58 RT.  
INPL. 12"x 32" C.M.P.  
REMOVE  
F.&I. 15"x 46" C.M.P. CULVERT  
F.&I. 2 - 15" C.M.P. APRONS

STA. 285+18 RT.  
INPL. 12"x 36" C.M.P.  
REMOVE  
F.&I. 15"x 42" C.M.P. CULVERT  
F.&I. 2 - 15" C.M.P. APRONS

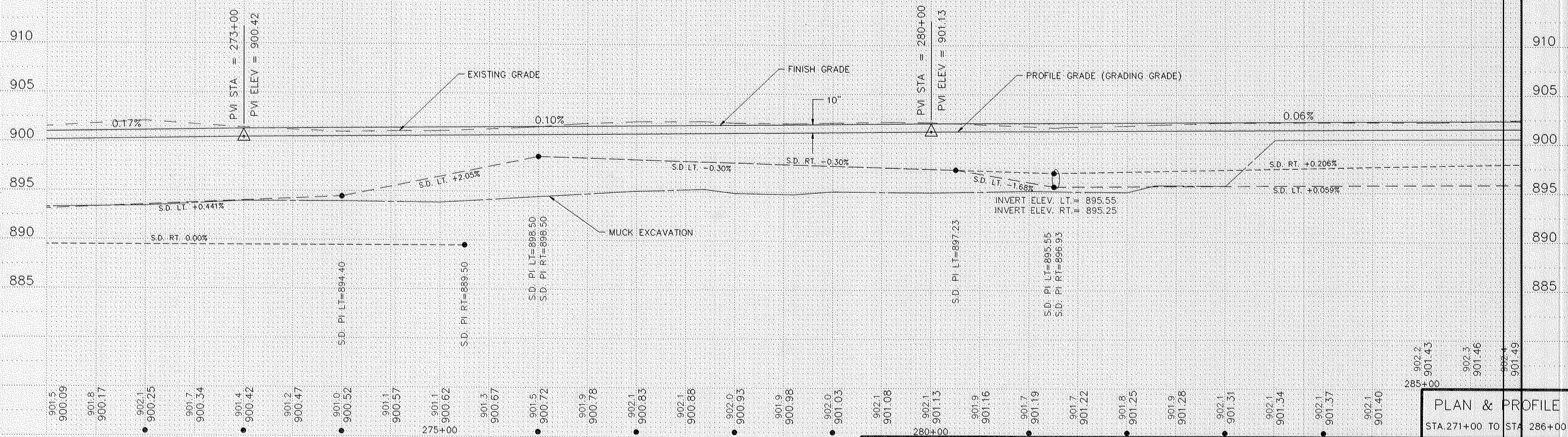

REVISIONS	DATE	BY

PLAN & PROFILE  
STA. 271+00 TO STA. 286+00







**EXCAVATION EMBANKMENT**  
SUB-TOTALS CU.YDS. SUB-TOTALS CU.YDS.

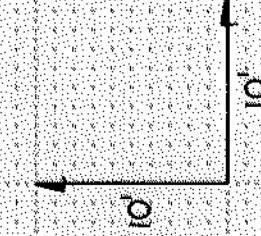
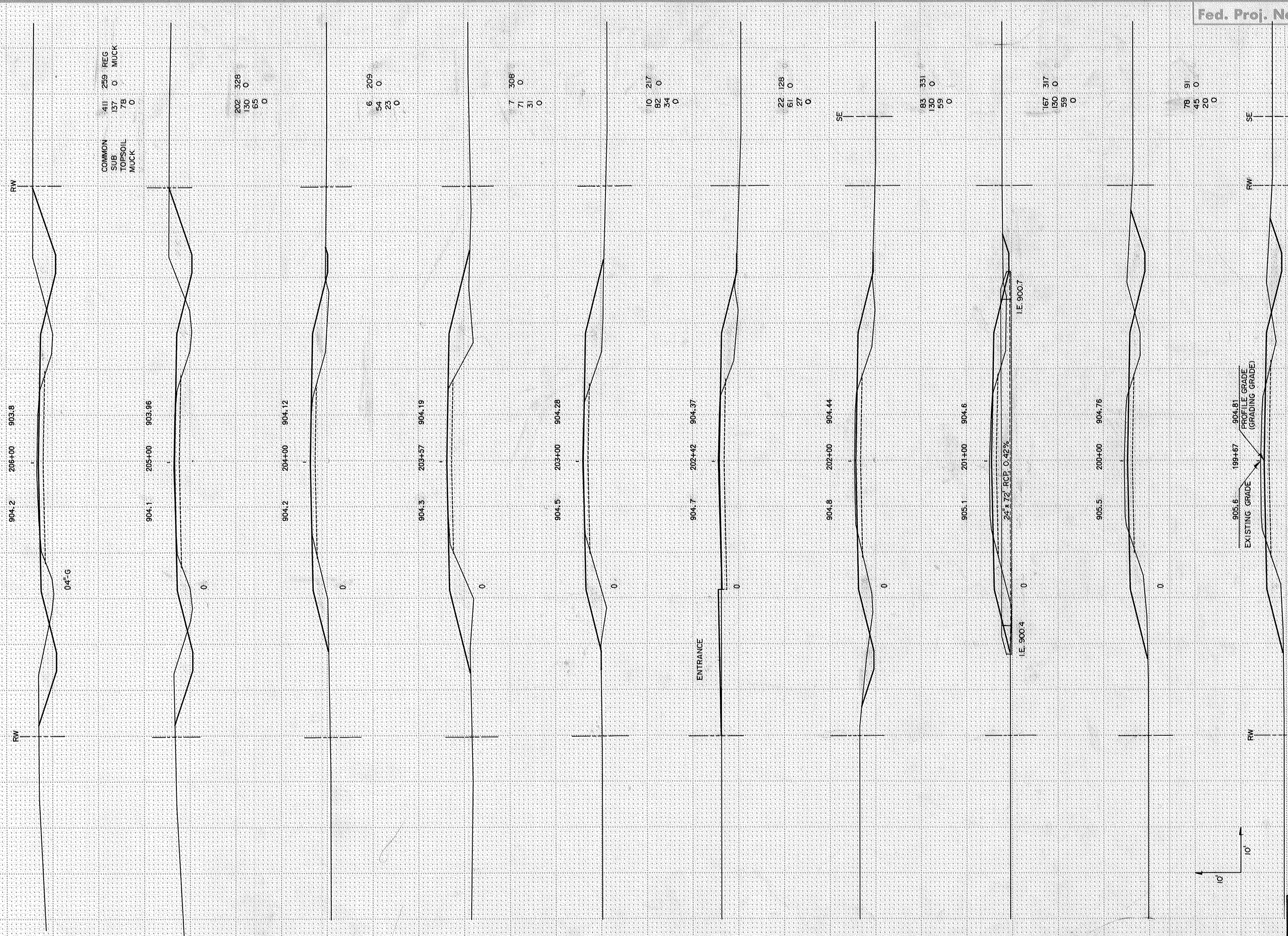

NOTE:  
UTILITY ELEVATIONS ASSUMED  
NOT ACTUAL

Fed. Proj. No.



**EXCAVATION EMBANKMENT**  
SUB-TOTALS CU.YDS. SUB-TOTALS CU.YDS.

Fed. Proj. No.

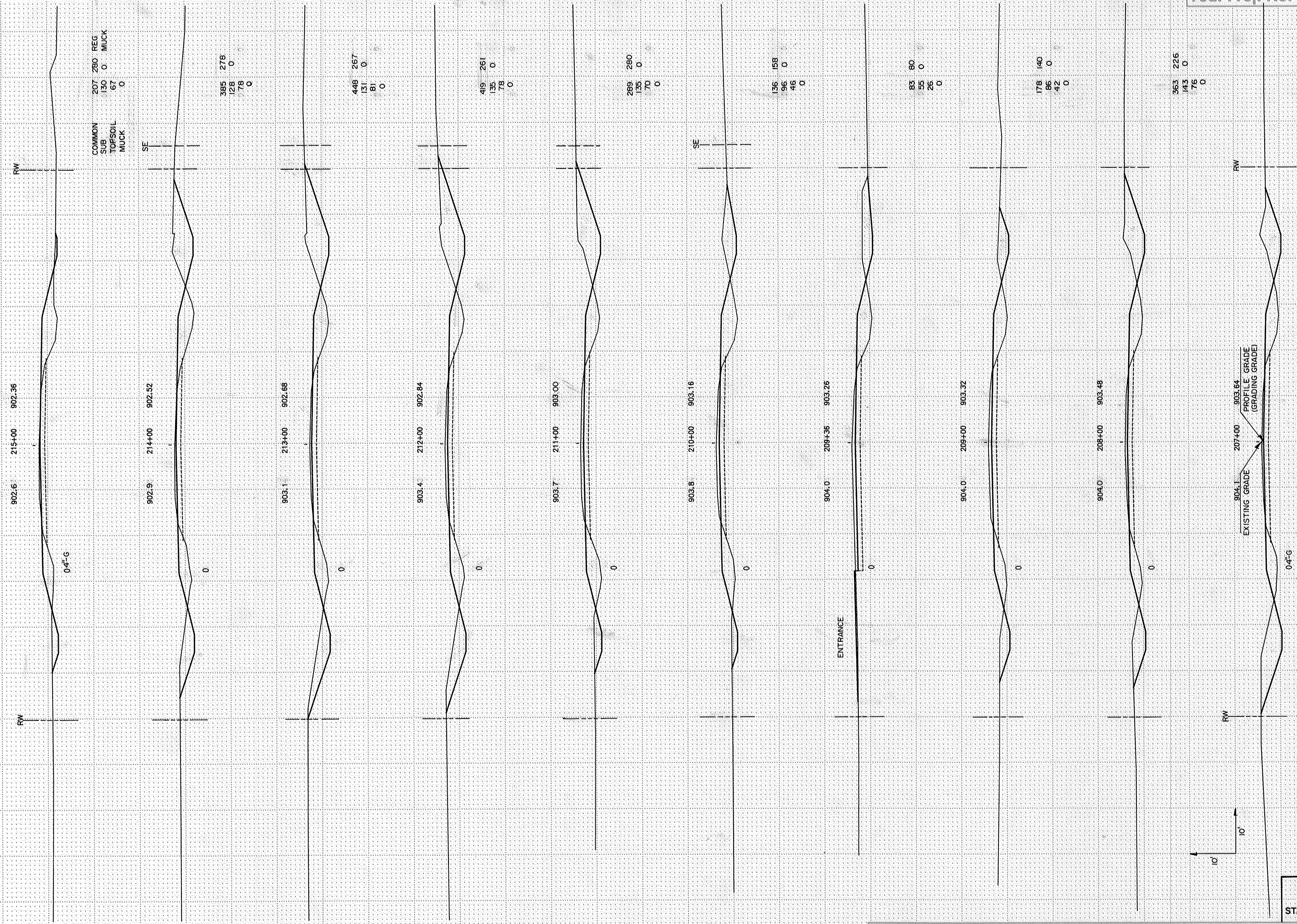

COMMON	207	280	REG
SUB	130	0	MUCK
TOPSOIL	67	0	
MUCK	0	0	

385	278
128	0
78	0

448	267
131	0
81	0

419	261
135	0
78	0

289	280
135	0
70	0

136	158
56	0
46	0

83	80
55	0
26	0

178	140
86	0
42	0

363	226
143	0
76	0

409	230
139	0
78	0

NOTE:  
UTILITY ELEVATIONS ASSUMED  
NOT ACTUAL

CROSS-SECTIONS  
STA. 207+00 TO STA. 215+00



**EXCAVATION EMBANKMENT**  
SUB-TOTALS CU.YDS. SUB-TOTALS CU.YDS.

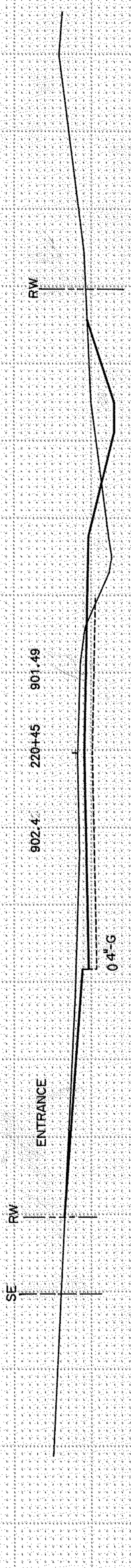

COMMON	170	83	REG
SUB	69	0	MUCK
TOPSOIL	36	0	
MUCK	0	0	

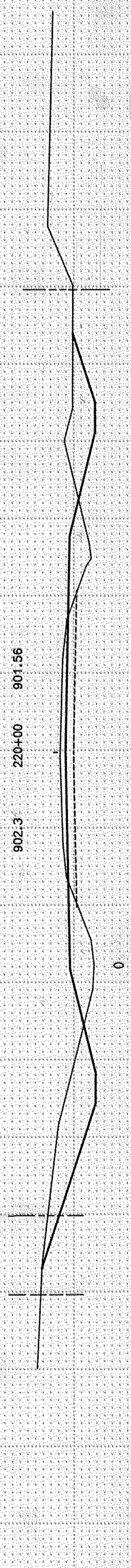

496	239
137	0
85	0
0	0

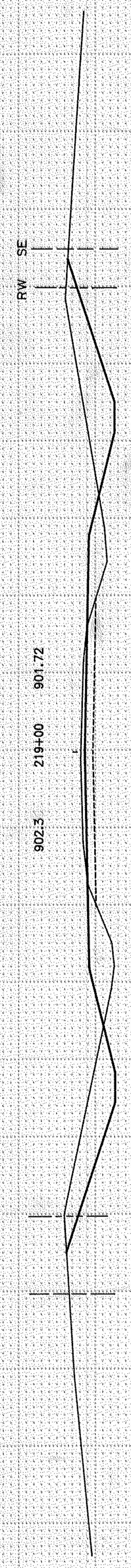

202	98
53	0
34	0
0	0

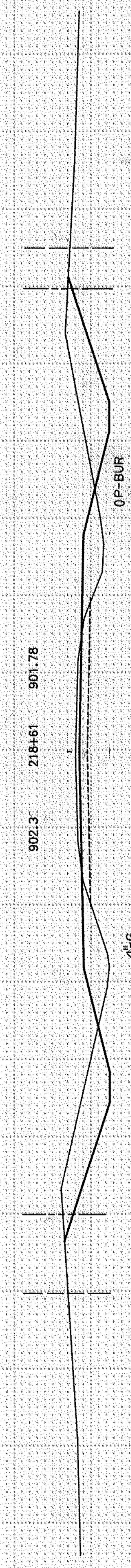

242	157
75	0
46	0
0	0

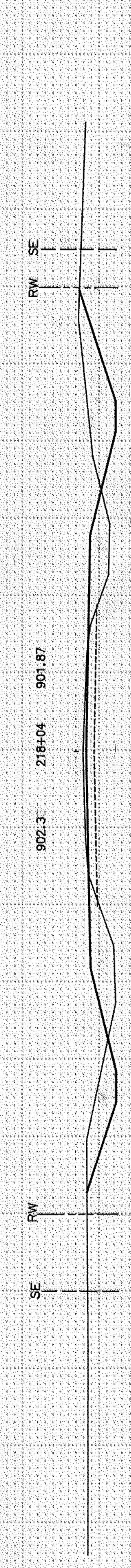

43	36
29	0
13	0
0	0

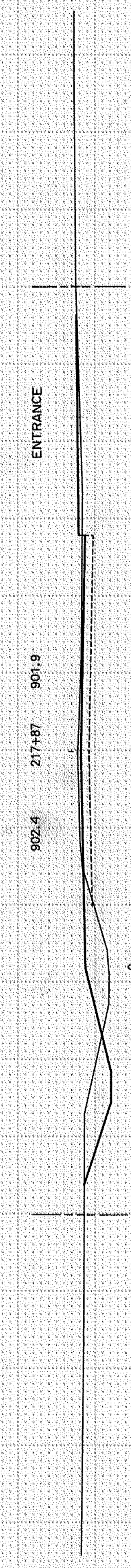

111	288
147	7
52	0
156	0

STA. 217+35 END MUCK EXC

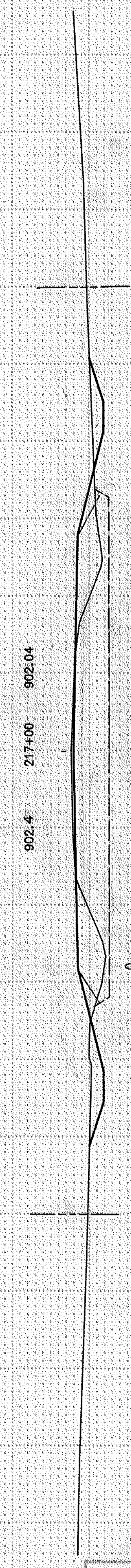

0	1217
0	69
0	0
0	1071

902.7 216+00 902.2

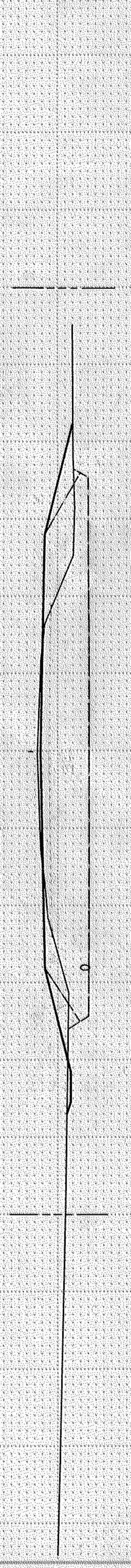

0	464
0	19
0	0
0	424

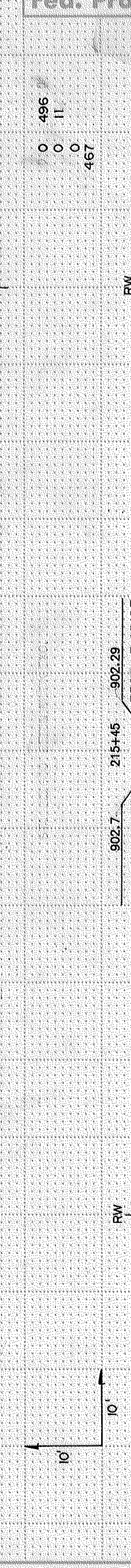
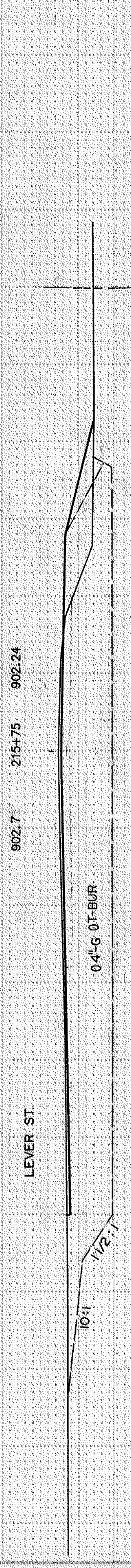

0	496
0	11
0	0
0	467

STA. 215+20 BEGIN MUCK EXC.

NOTE  
UTILITY ELEVATIONS ASSUMED  
NOT ACTUAL

21	220
44	3
19	0
122	0

Fed. Proj. No.

City Embankment Form #1 BR3032



**EXCAVATION EMBANKMENT**  
SUB-TOTALS CU.YDS. SUB-TOTALS CU.YDS.

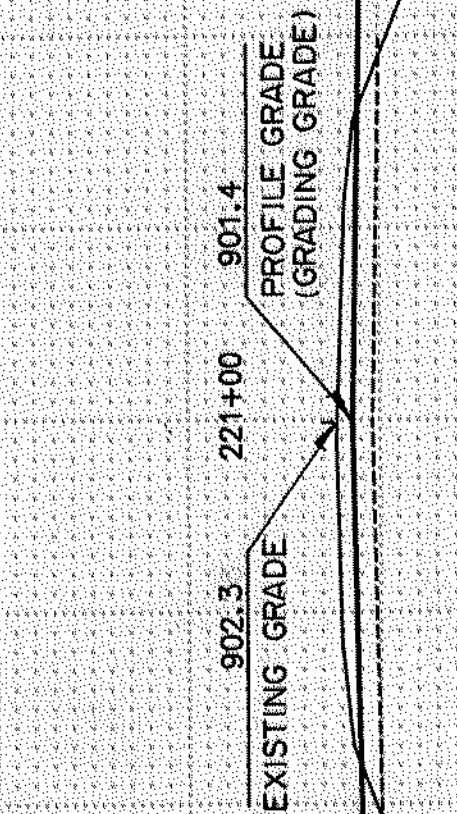
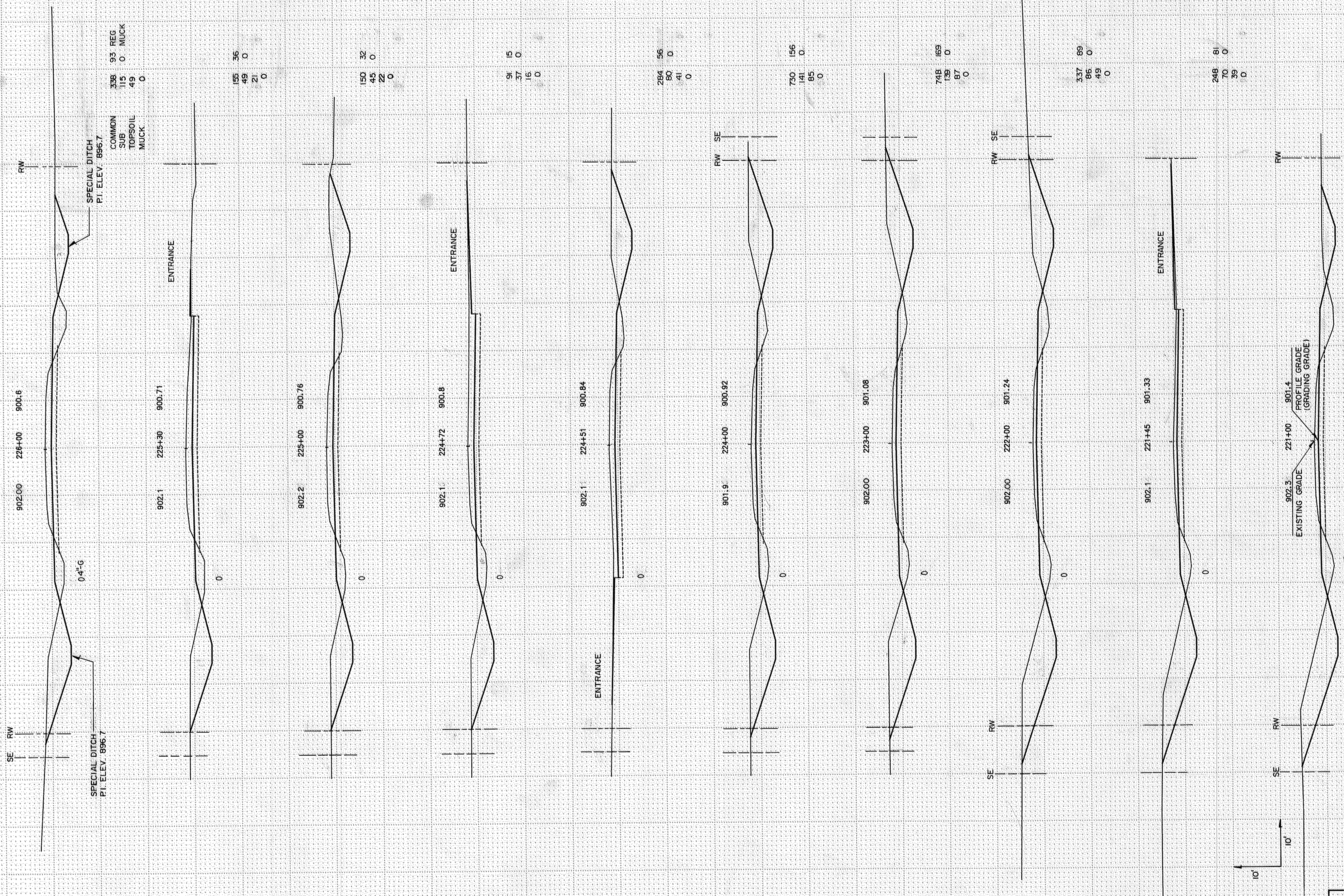

NOTE:  
UTILITY ELEVATIONS ASSUMED  
NOT ACTUAL



**EXCAVATION EMBANKMENT**  
SUB-TOTALS CU.YDS. SUB-TOTALS CU.YDS.

900.8 232+00 899.8

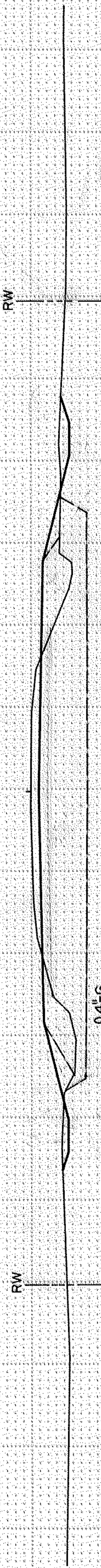

COMMON	0	1226	REG
SUB	0	56	MUCK
TOPSOIL	0		
MUCK	1103		

900.7 231+00 899.8

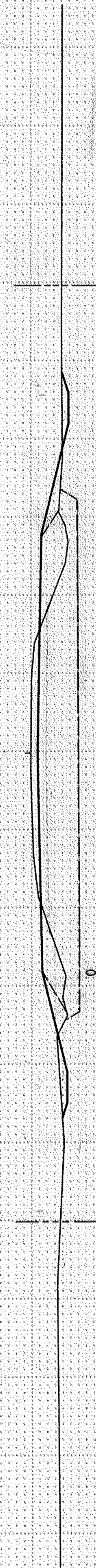

68	477
61	17
26	255

STA. 230+50 BEG. MUCK EXC.

901.00 230+29 899.91

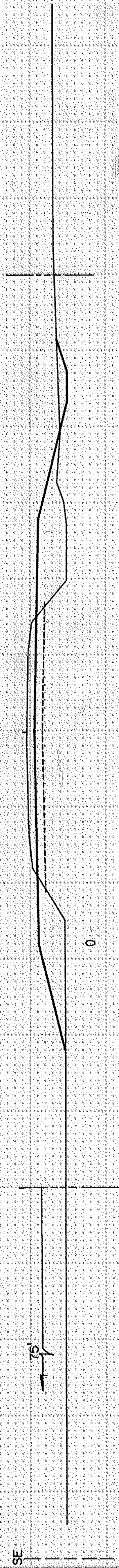

53	106
41	0
18	0

901.2 230+00 899.96

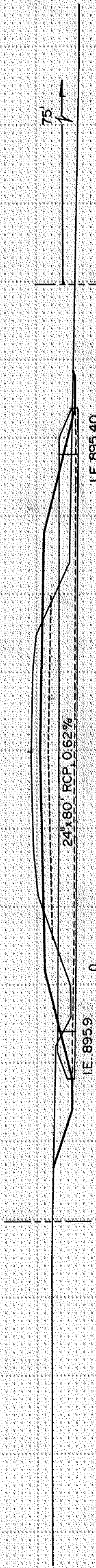

201	218
120	0
55	0

901.3 229+20 900.09

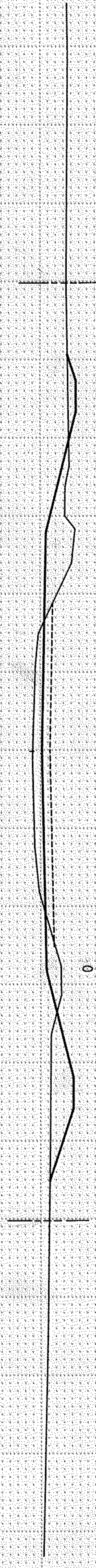

72	59
48	0
18	0

901.4 228+90 900.13

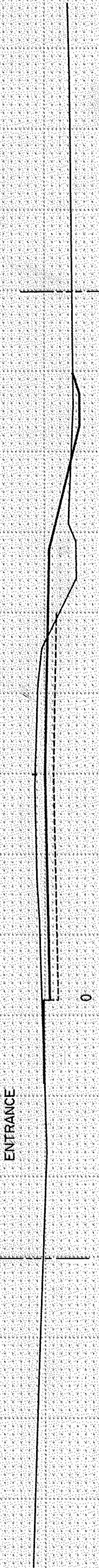

257	162
143	0
57	0

901.5 228+00 900.28

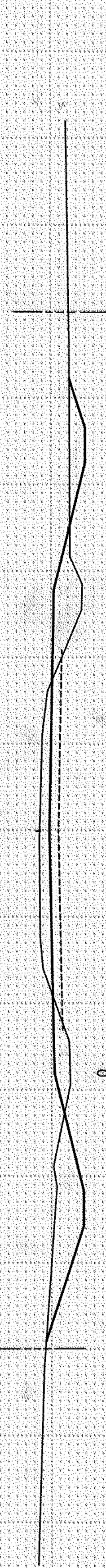

413	180
150	0
74	0

901.6 227+00 900.44

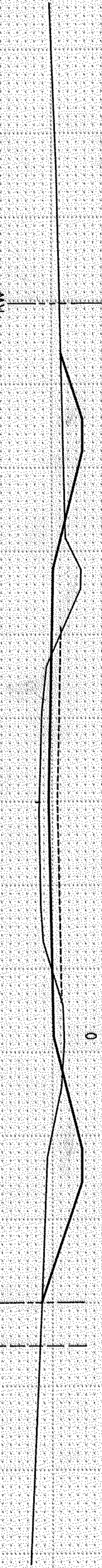

46	19
21	0
9	0

901.7 226+87 900.46

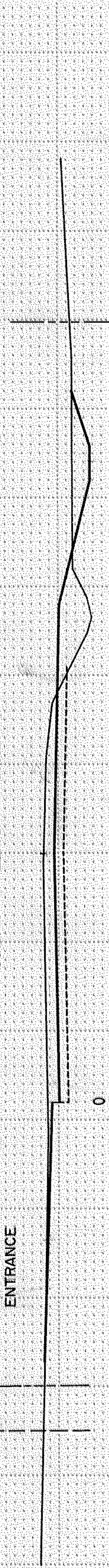

186	70
100	0
40	0

901.9 226+30 900.55

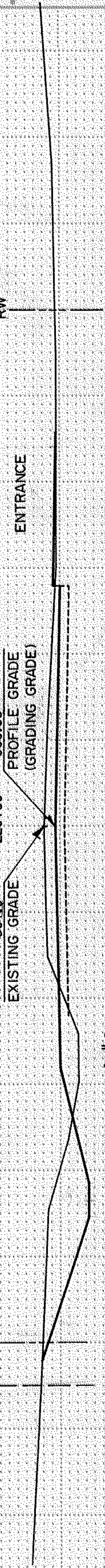

146	44
45	0
22	0

NOTE:  
UTILITY ELEVATIONS ASSUMED  
NOT ACTUAL

Fed. Proj. No.



**EXCAVATION EMBANKMENT**  
SUB-TOTALS CU. YDS. SUB-TOTALS CU. YDS.

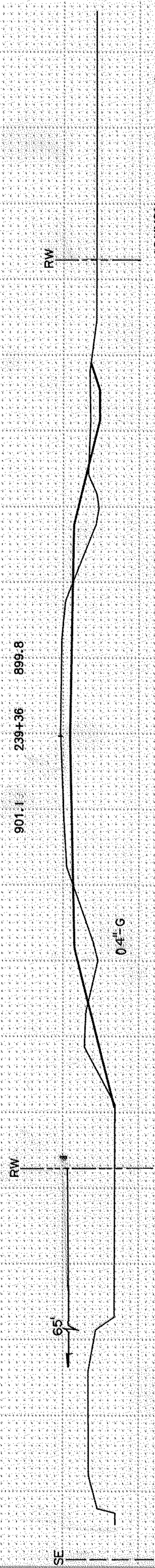

COMMON	65	71	REG
SUB	59	0	MUCK
TOPSOIL	21	0	
MUCK	0	0	

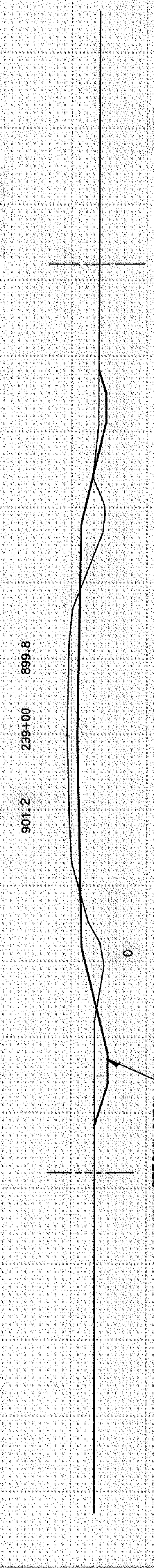

446	157
165	0
70	0
0	0

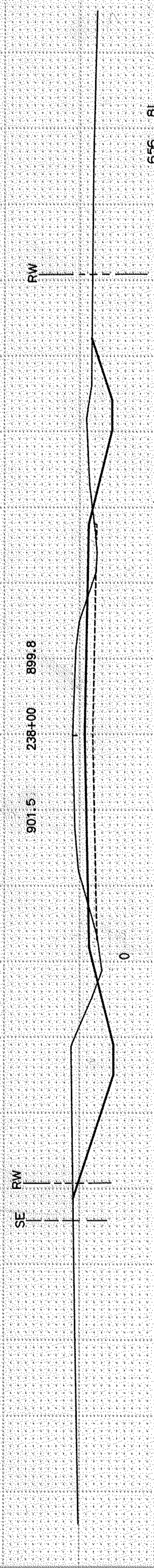

656	81
167	0
78	0
0	0

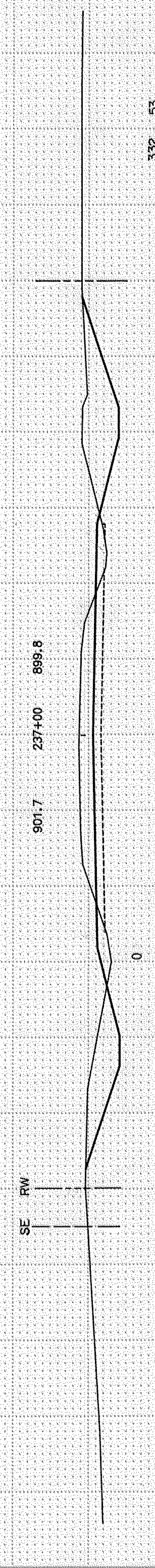

332	53
105	0
45	0
0	0

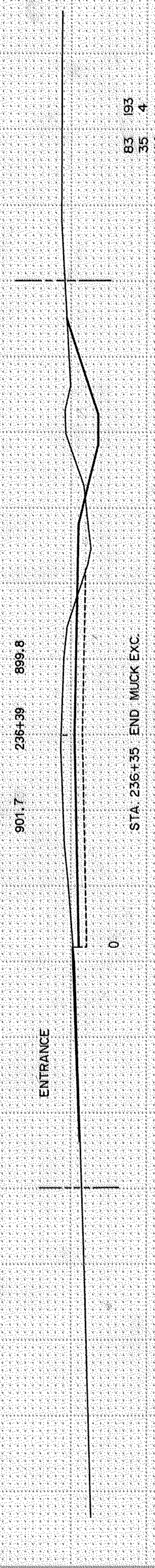

83	193
35	4
14	220
0	0

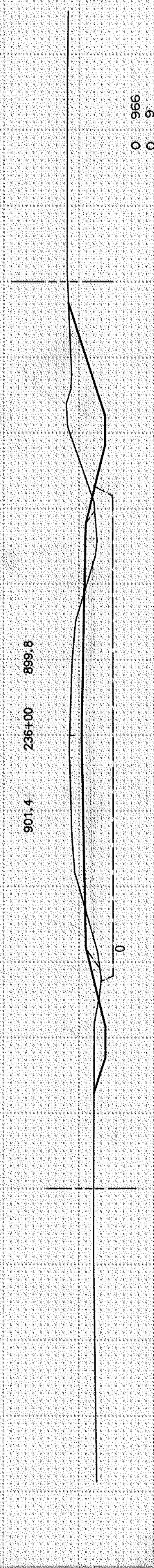

0	966
0	5
0	0
1205	0

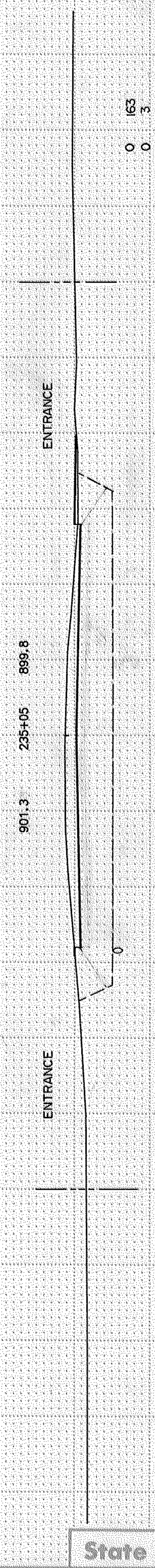

0	163
0	3
0	0
183	0

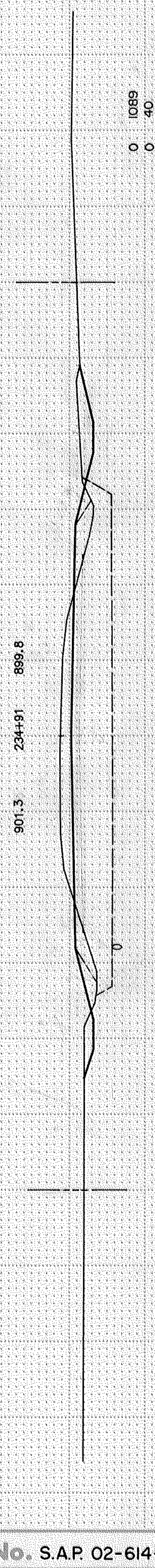

0	1089
0	40
0	0
1072	0

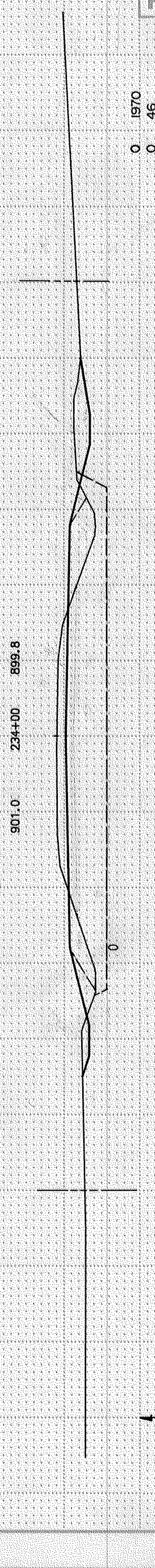

0	1970
0	46
0	0
1243	0

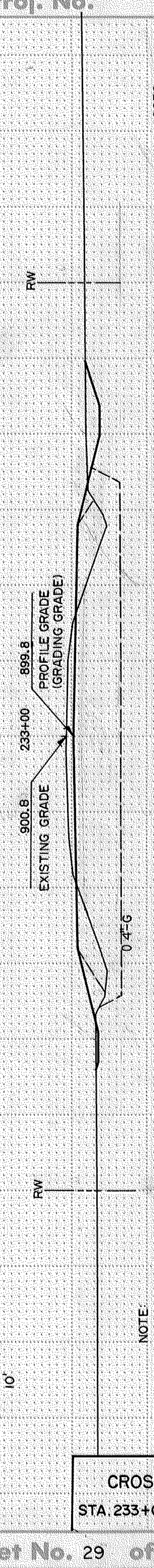

0	2030
0	46
0	0
1261	0

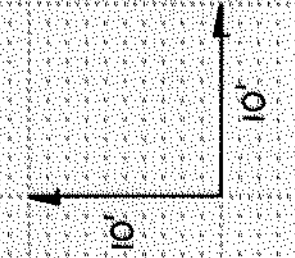

NOTE:  
UTILITY ELEVATIONS ASSUMED  
NOT ACTUAL

Fed. Proj. No.



**EXCAVATION EMBANKMENT**  
SUB-TOTALS CU.YDS. SUB-TOTALS CU.YDS.

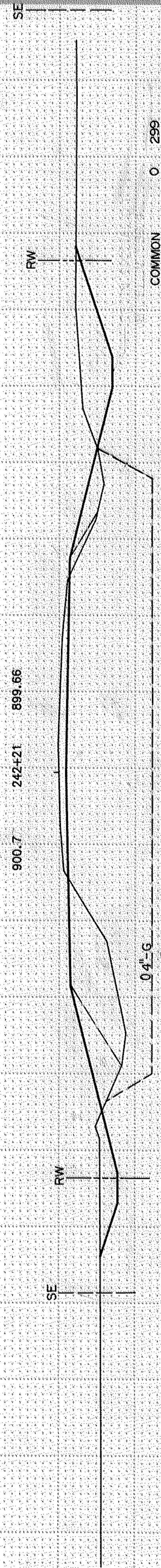

COMMON	0	299
SUB	0	13
TOPSOIL	0	0
MUCK	0	290

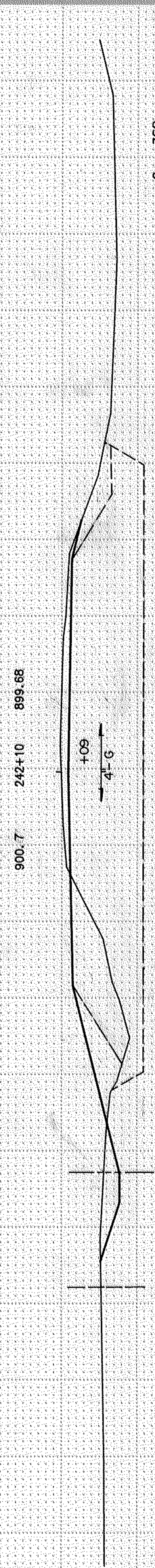

0	362
0	14
0	0
0	342

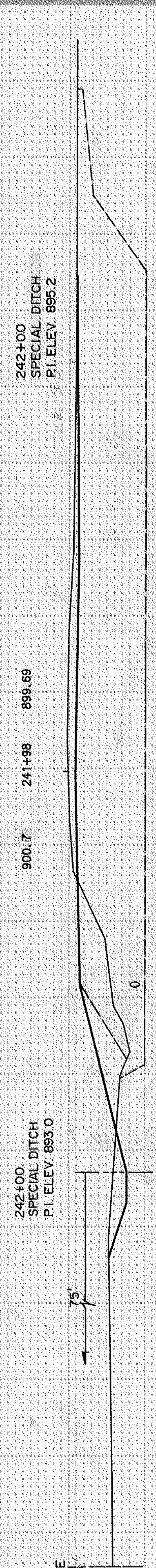

242+00  
SPECIAL DITCH  
P.I. ELEV. 895.2

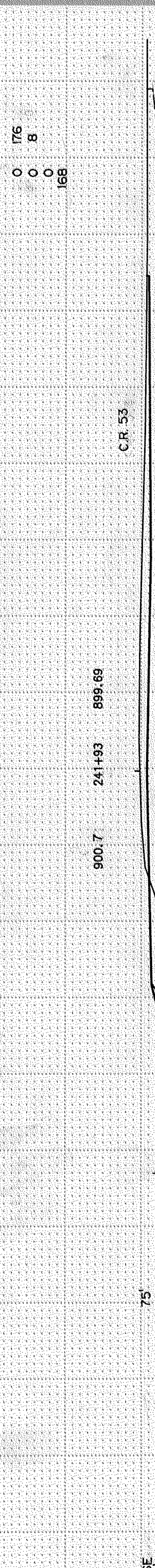

0	176
0	8
0	0
0	168

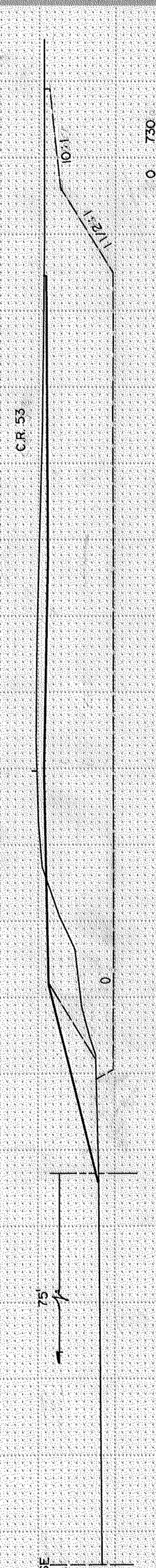

0	730
0	53
0	0
0	705

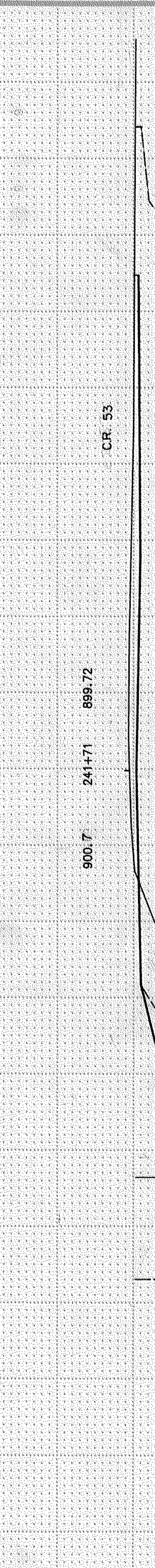
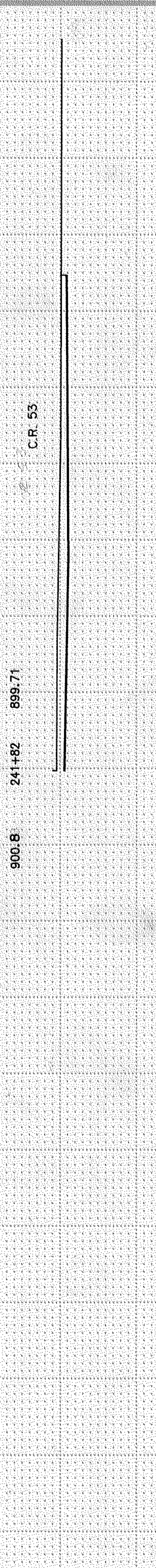

0	174
0	7
0	0
0	171

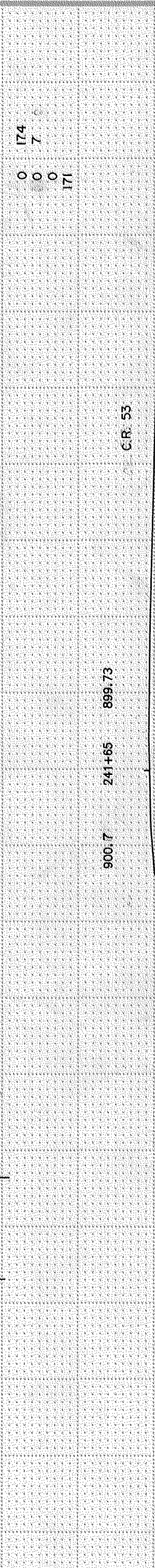

0	237
0	14
0	0
0	230

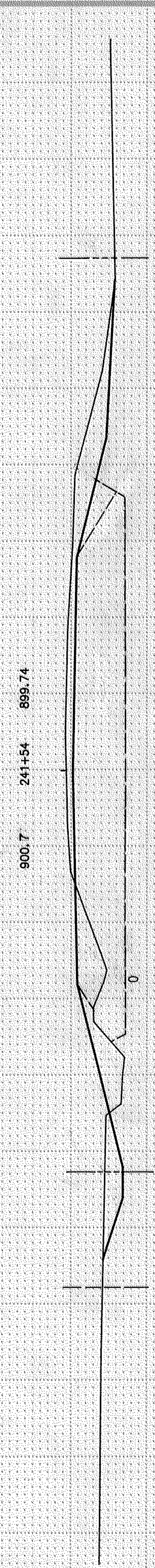
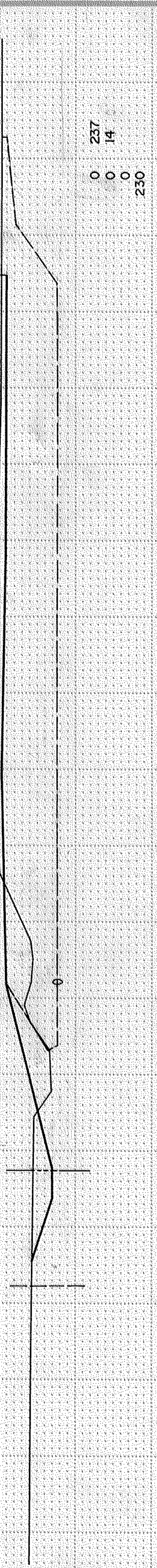

0	173
0	144
0	0
0	169

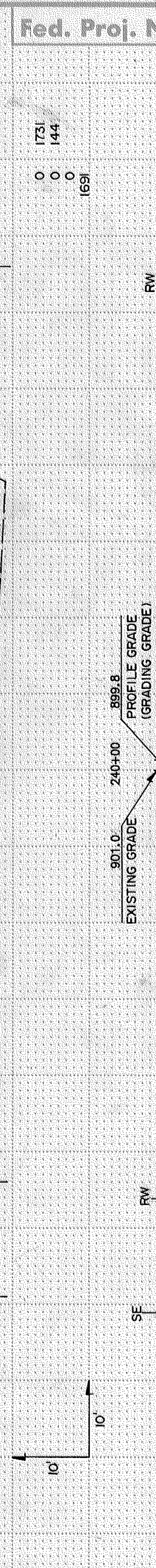
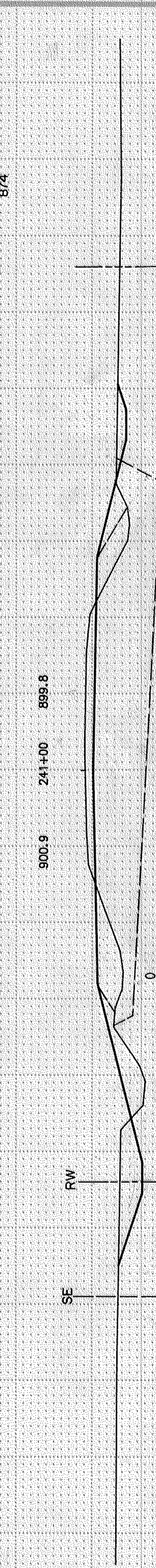

0	73
0	51
0	18
0	557

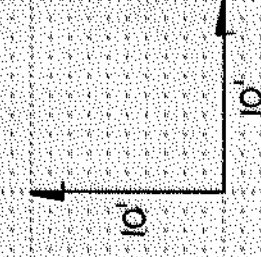

NOTE:  
UTILITY ELEVATIONS ASSUMED  
NOT ACTUAL

Fed. Proj. No.

CROSS-SECTIONS  
STA. 240+00 TO STA. 242+21



**EXCAVATION EMBANKMENT**  
SUB-TOTALS CU.YDS. SUB-TOTALS CU.YDS.

901.0 247+00 899.13

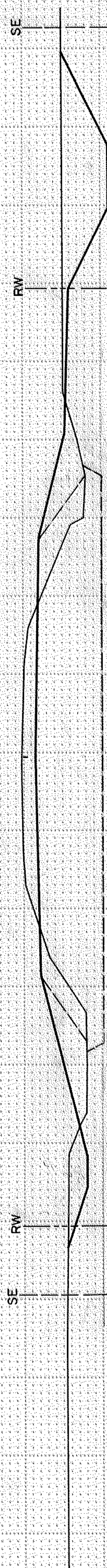

COMMON	0	1894	REG
SUB	0	265	MUCK
TOPSOIL	0		
MUCK	0	2224	

901.0 246+00 899.25

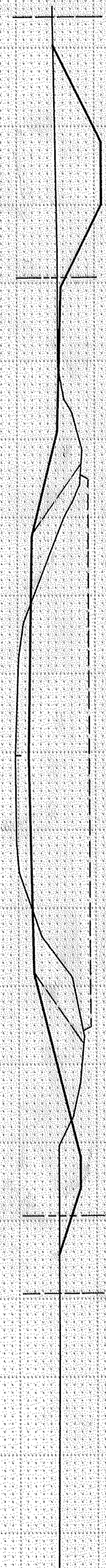

0	1201
0	167
0	
0	1342

901.00 245+41 899.31

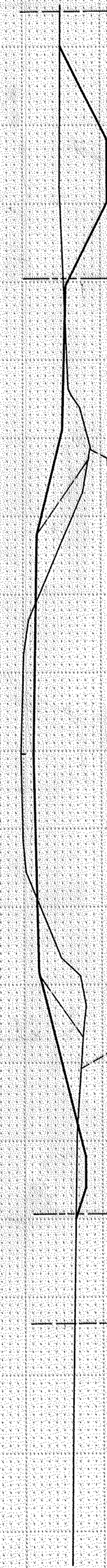

0	855
0	121
0	
0	960

901.0 245+00 899.36

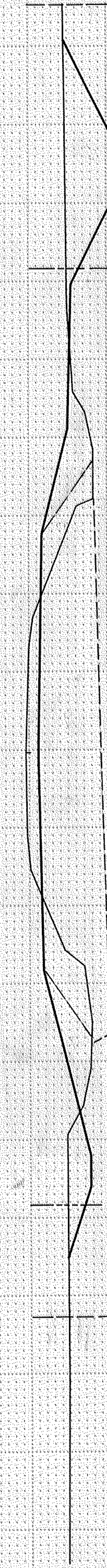

0	1791
0	278
0	
0	2121

900.8 244+00 899.47

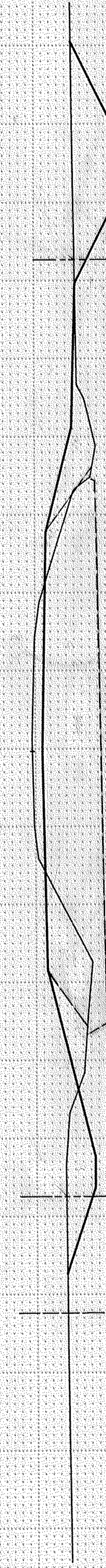

0	473
0	54
0	
0	577

900.8 243+75 899.49

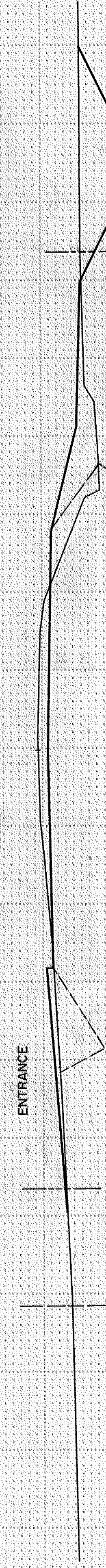

0	1776
0	188
0	
0	1972

900.8 243+00 899.58

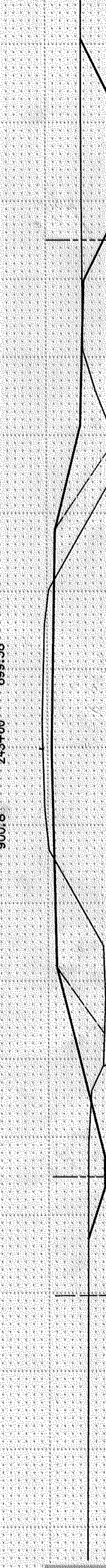

0	1116
0	140
0	
0	1152

900.7 242+60 899.62

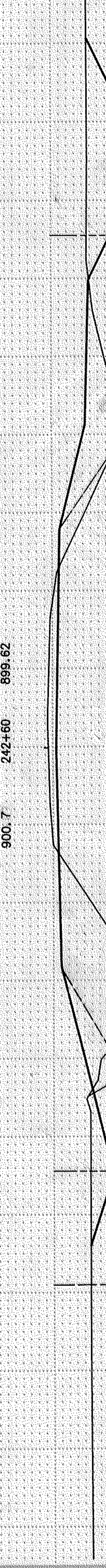

0	267
0	28
0	
0	260

900.7 242+51 899.63

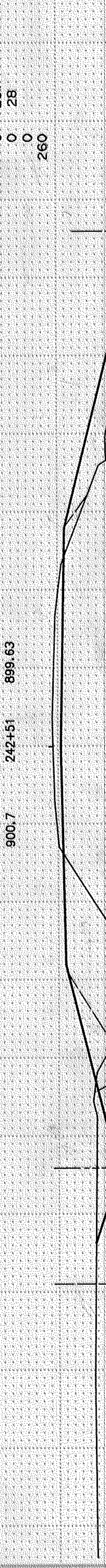

0	526
0	37
0	
0	517

900.7 242+33 899.65

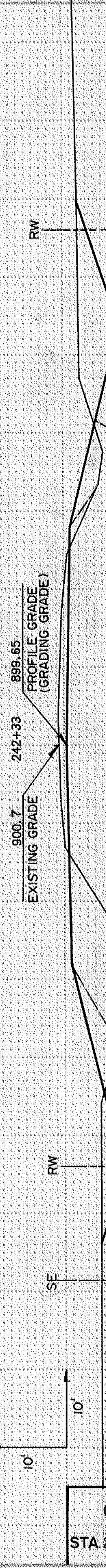

0	354
0	17
0	
0	360

Fed. Proj. No.

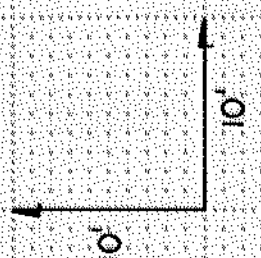



**EXCAVATION EMBANKMENT**  
SUB-TOTALS CU.YDS. SUB-TOTALS CU.YDS.

900.5 254+00 898.36

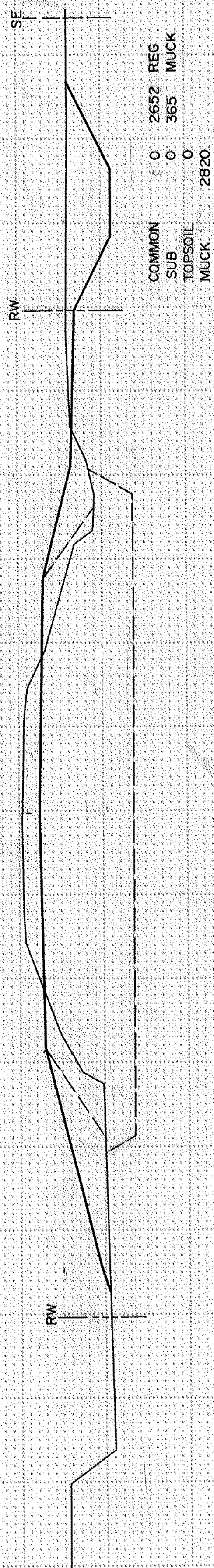

900.3 253+00 898.47

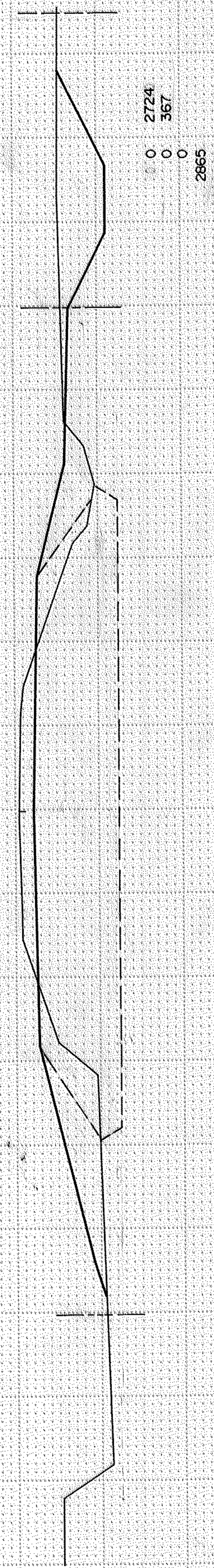

900.0 252+00 898.58

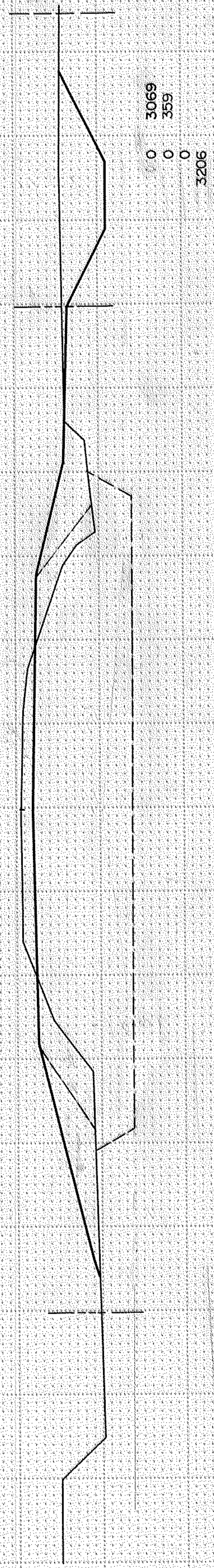

900.4 251+00 898.69

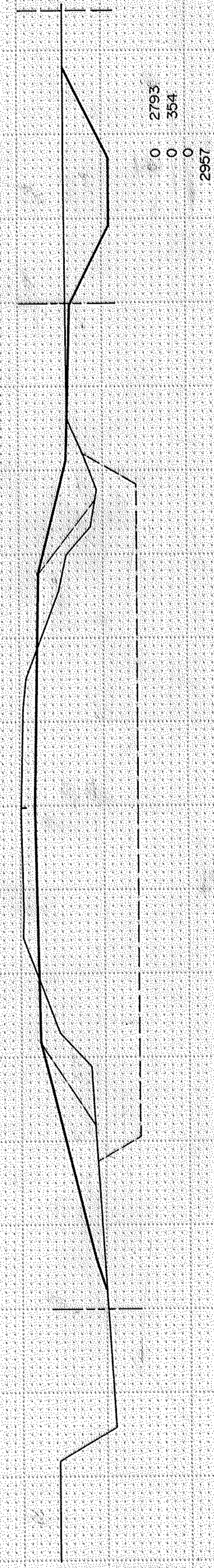

900.8 250+00 898.8

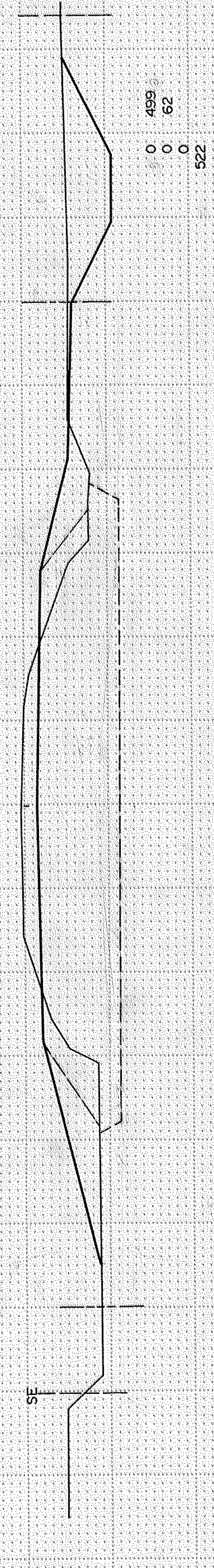

900.8 249+82 898.82

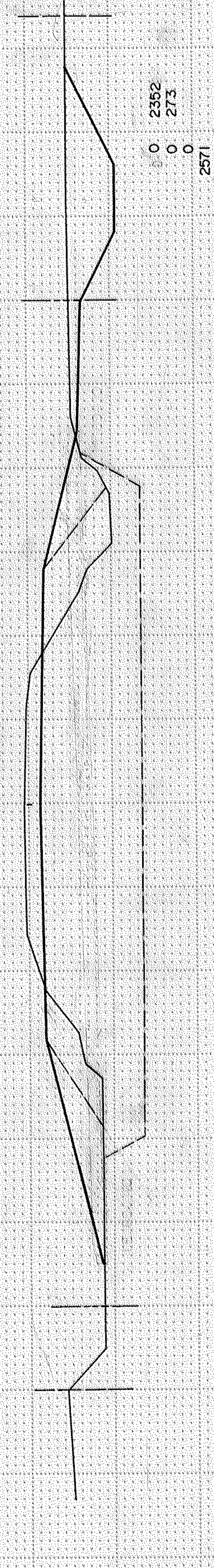

901.2 249+00 898.91

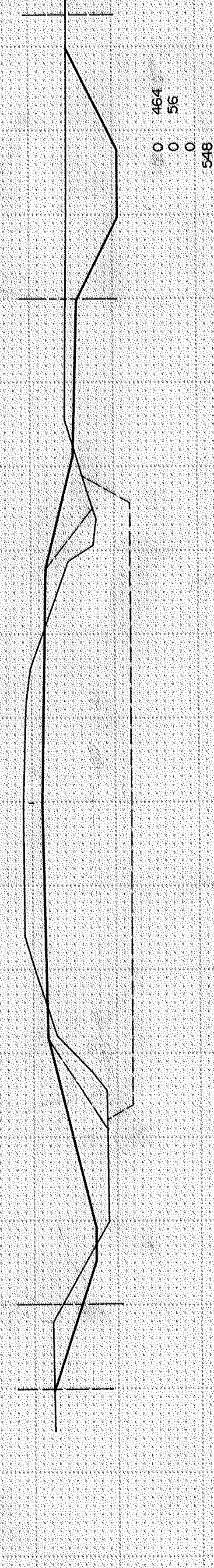

901.3 248+79 898.94

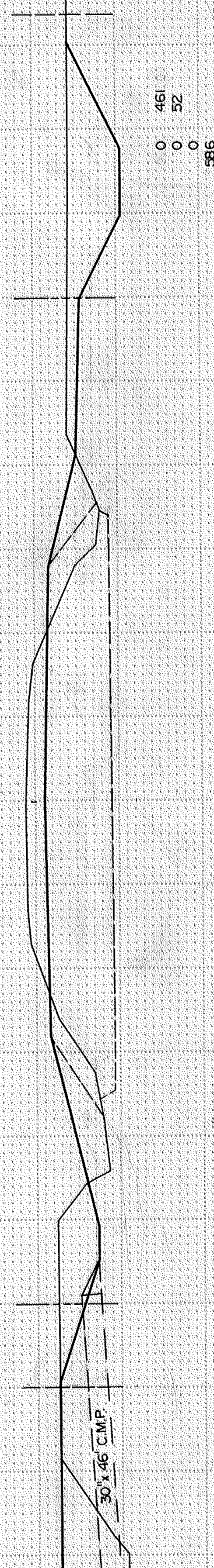

901.3 248+51 898.97

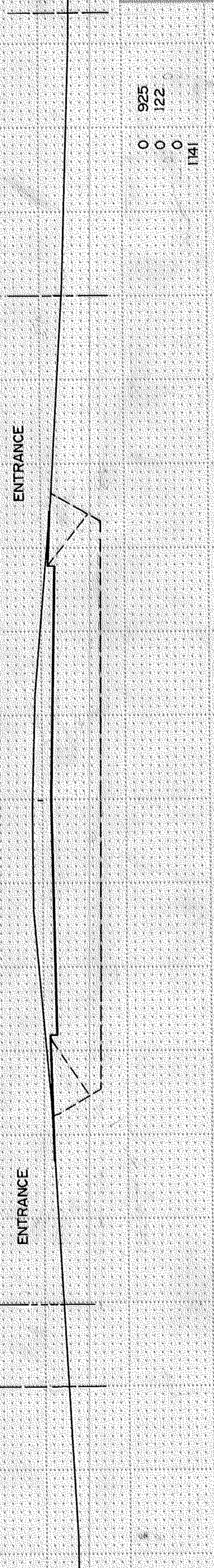

901.1 248+00 898.02

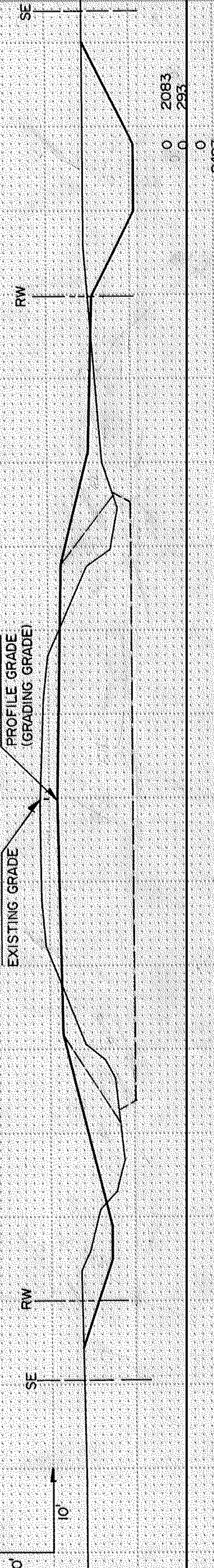

Fed. Proj. No.



**EXCAVATION EMBANKMENT**  
SUB-TOTALS CU.YDS. SUB-TOTALS CU.YDS.

899.38 262+00 898.59

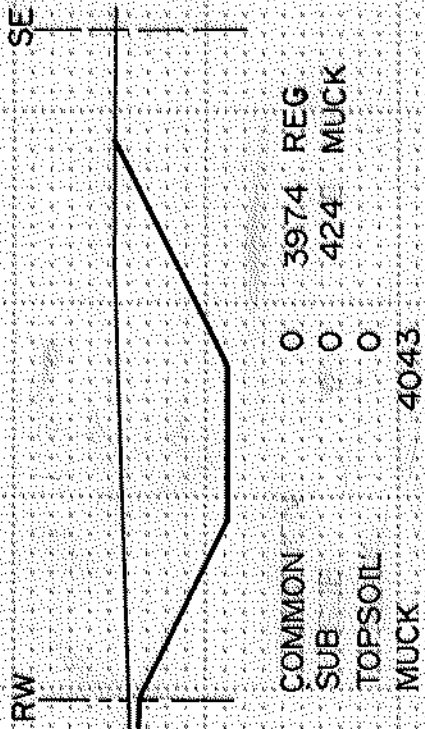

899.6 261+00 898.42

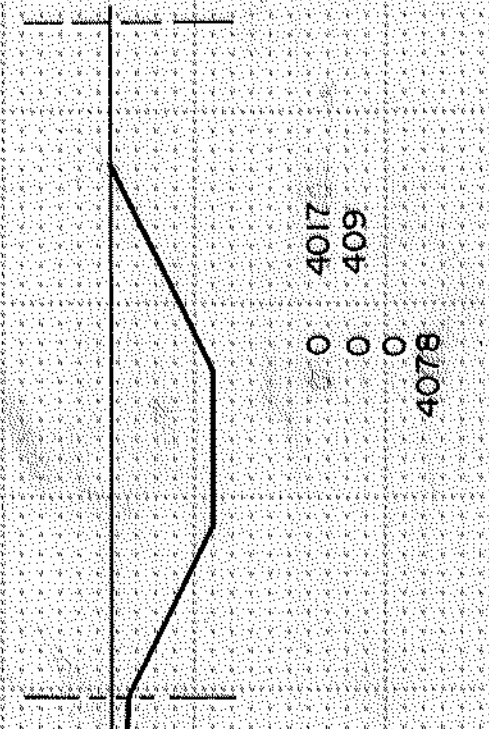

899.1 260+00 898.25

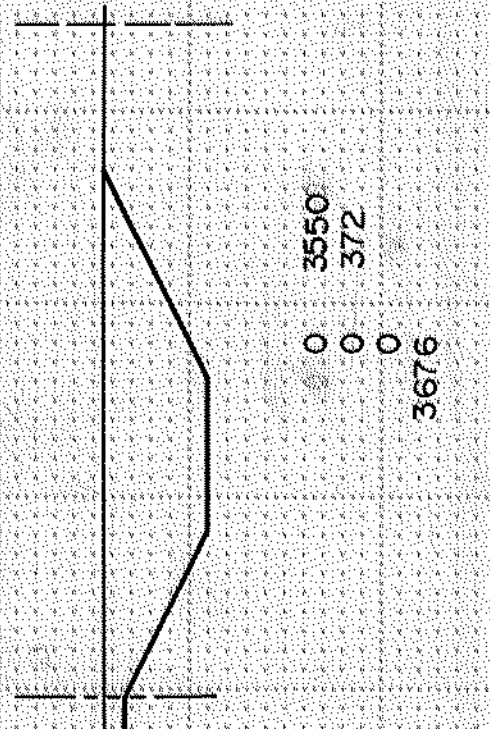

899.1 259+00 898.09

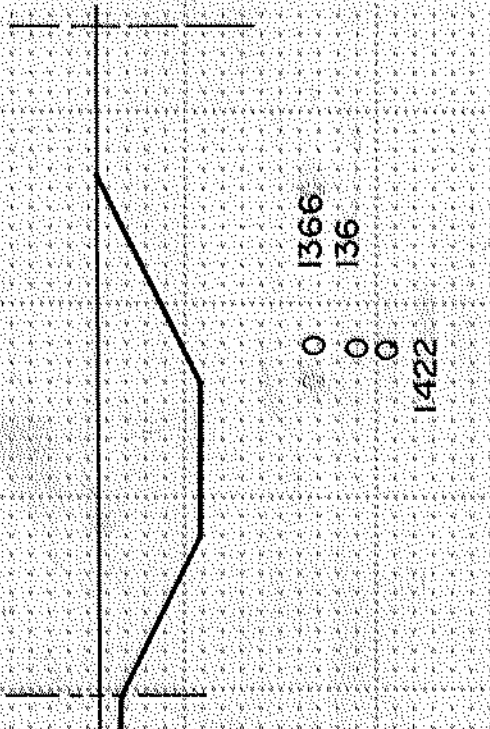

898.9 258+63 898.03

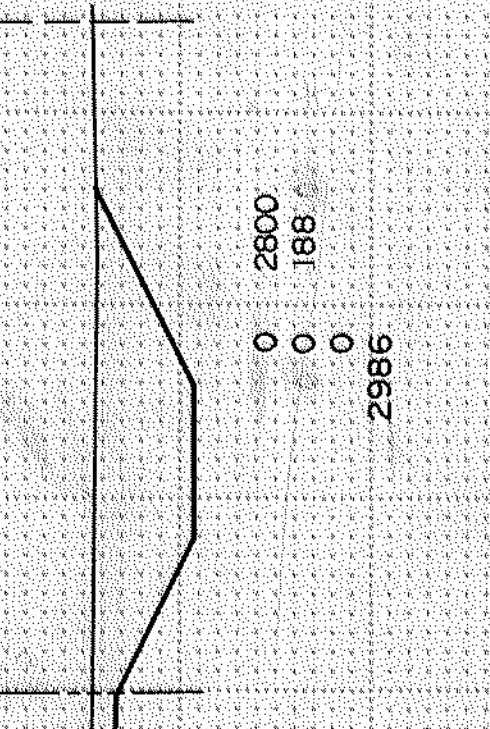

898.9 258+00 897.92

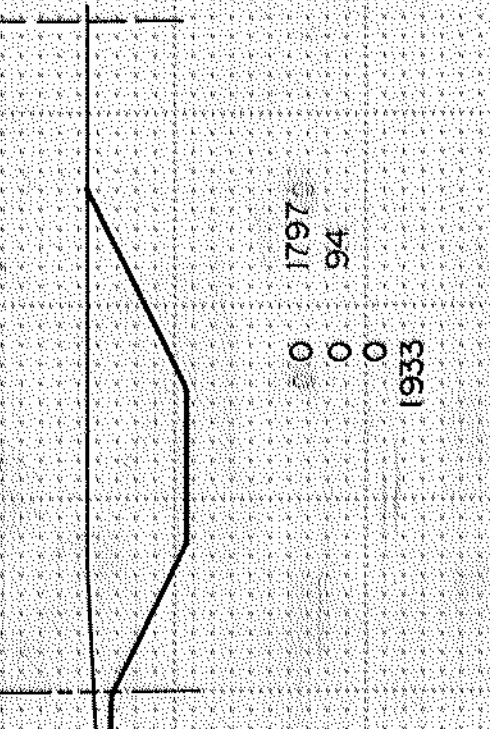

898.9 257+55 897.97

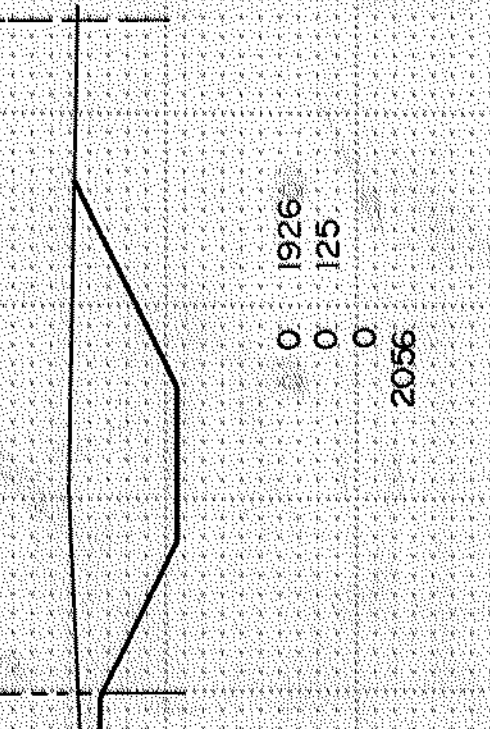

899.4 257+00 898.03

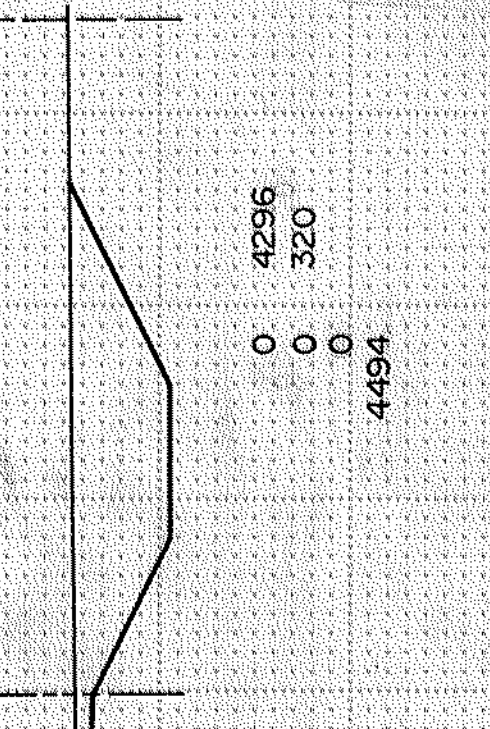

898.5 256+00 898.14

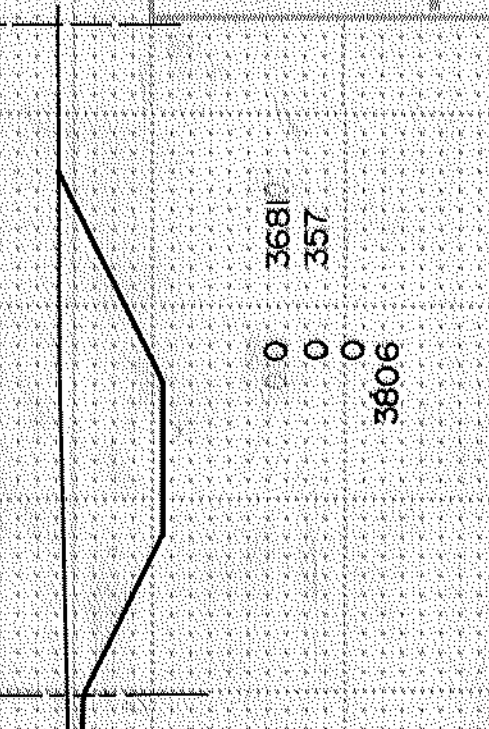

900.2 255+00 898.25

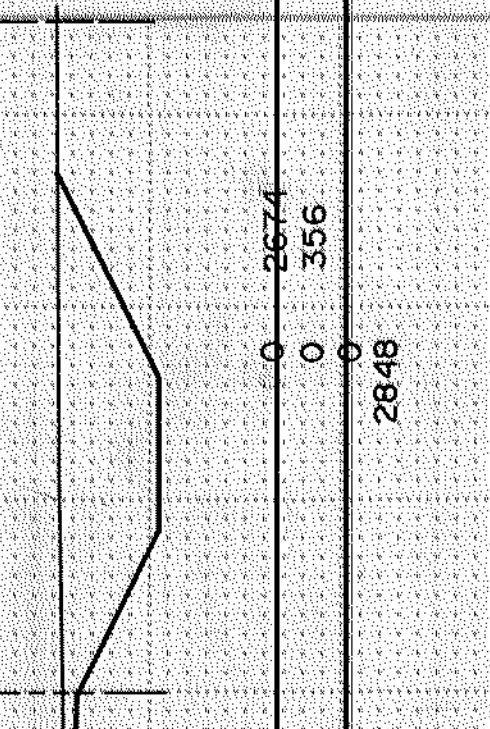

Fed. Proj. No.



**EXCAVATION EMBANKMENT**  
SUB-TOTALS CU.YDS. SUB-TOTALS CU.YDS.

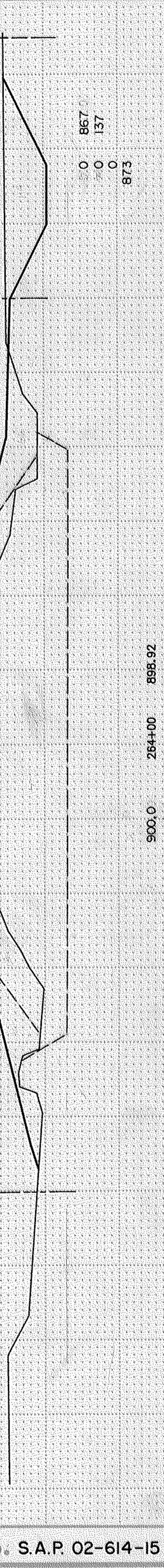
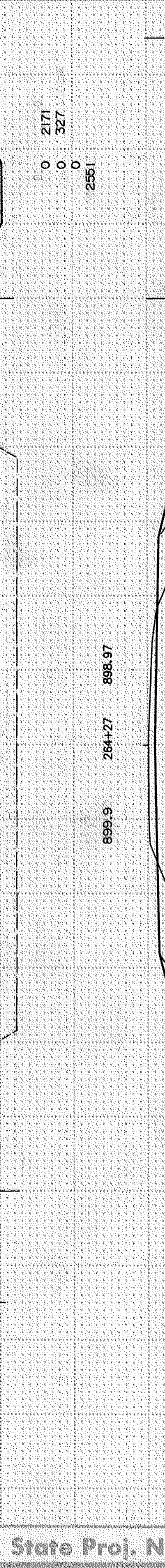
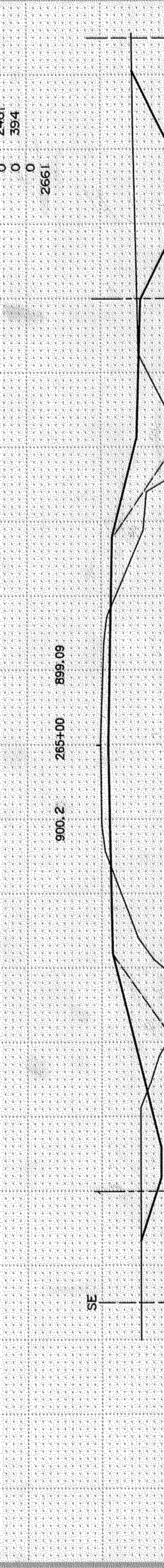
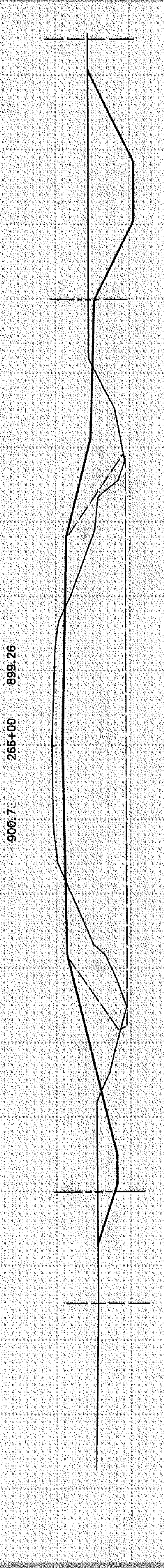
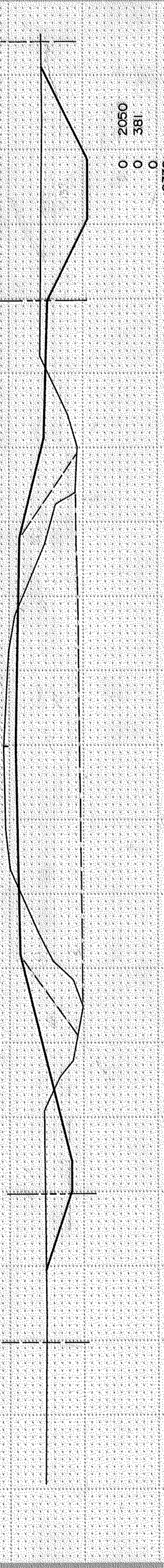
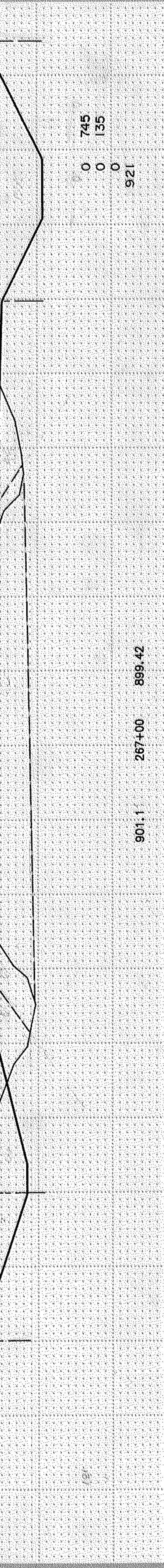
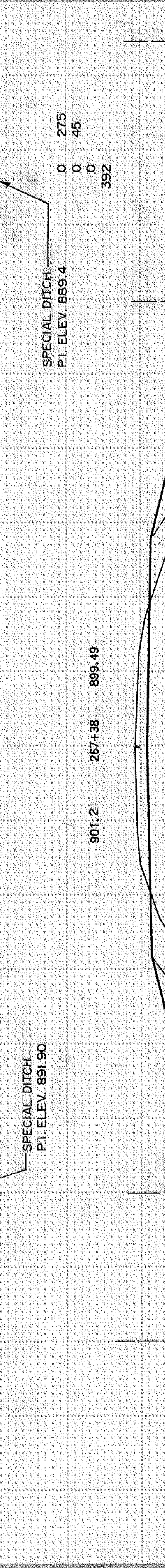
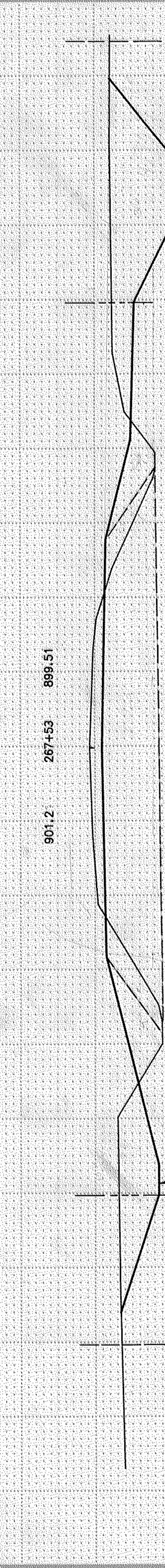
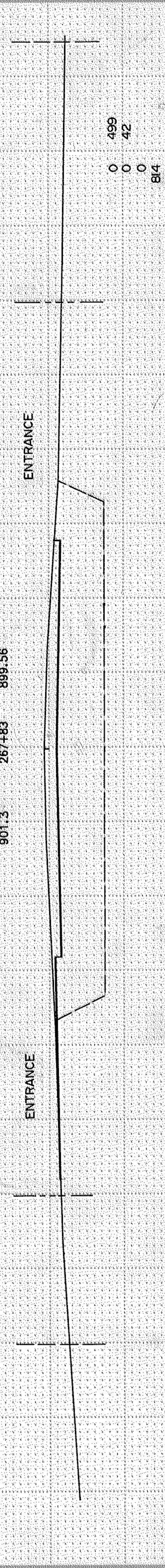
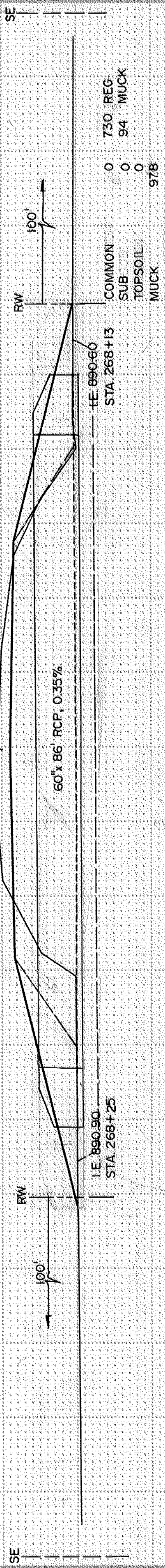

Fed. Proj. No.

898.8 EXISTING GRADE  
898.75 PROFILE GRADE (GRADING GRADE)

CROSS-SECTIONS  
STA. 263+00 TO STA. 268+14



**EXCAVATION EMBANKMENT**  
SUB-TOTALS CU. YDS. SUB-TOTALS CU. YDS.

STA. 275+25  
P.I. ELEV. 889.4

901.1 275+00 900.63

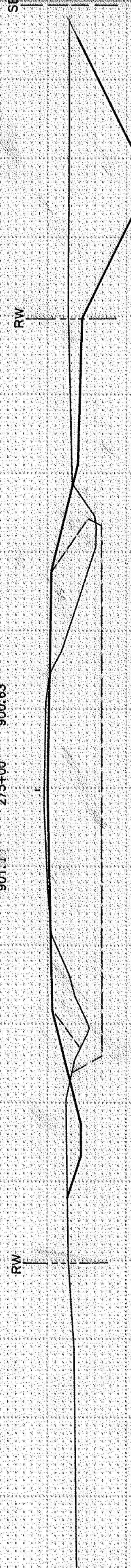

COMMON SUBTOPSOIL MUCK  
REG MUCK  
708 64  
0 0  
0 0  
0 962

901.1 274+54 900.58

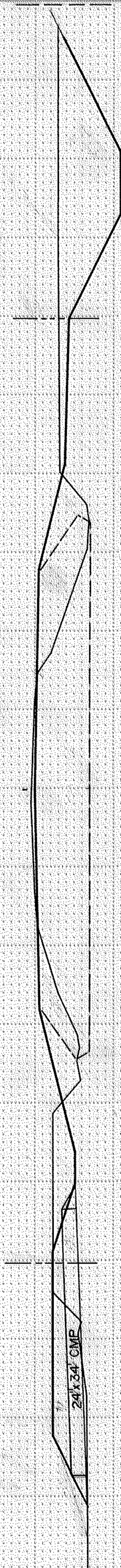

24' x 34' CMP

901.0 274+00 900.53

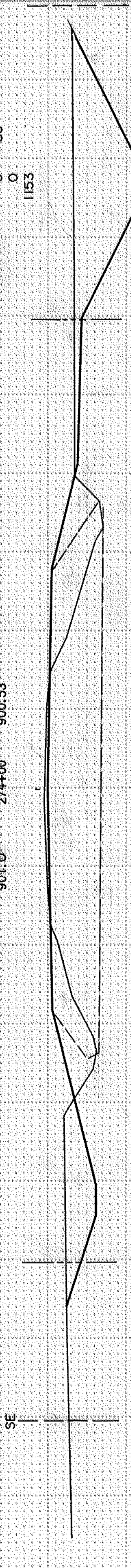

0 832  
0 86  
0 1153

901.4 273+00 900.42

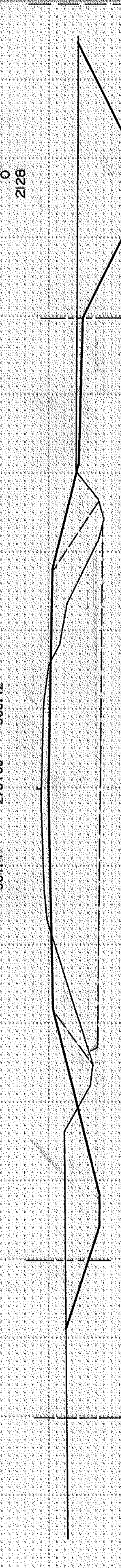

0 1507  
0 154  
0 2128

902.1 272+00 900.26



0 1543  
0 163  
0 2360

901.5 271+00 900.09

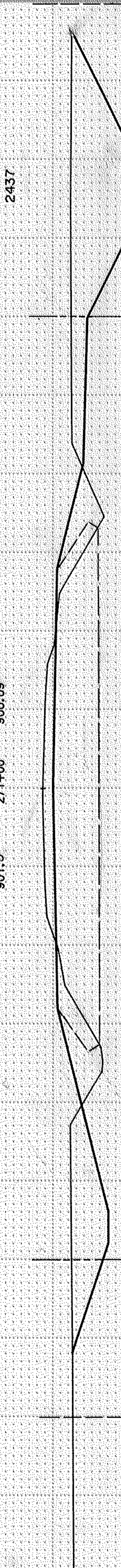

0 1424  
0 176  
0 2437

901.2 270+00 899.92

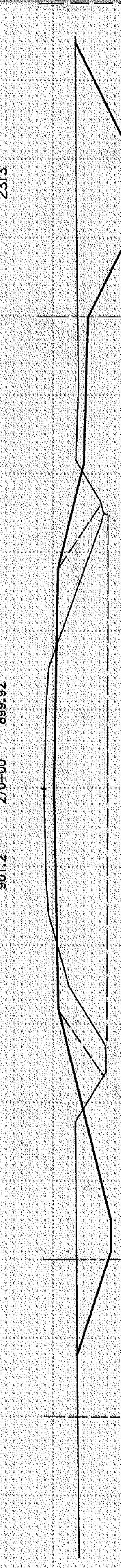

0 1396  
0 174  
0 2313

901.2 269+00 899.76

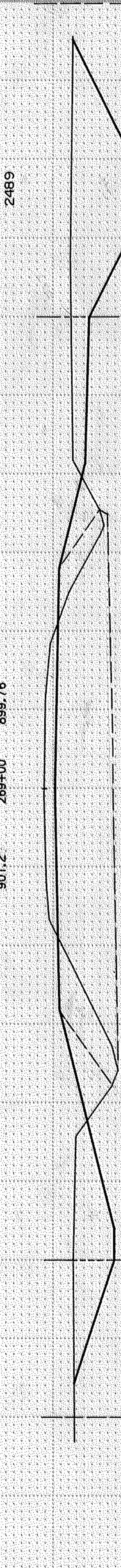

0 1624  
0 172  
0 2489

SPECIAL DITCH  
STA. 268+70  
P.I. ELEV. 889.50

901.3 268+47 899.67

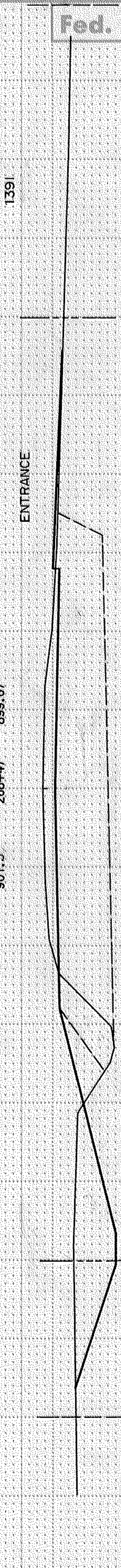

0 870  
0 69  
0 1391

ENTRANCE

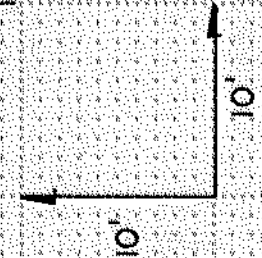
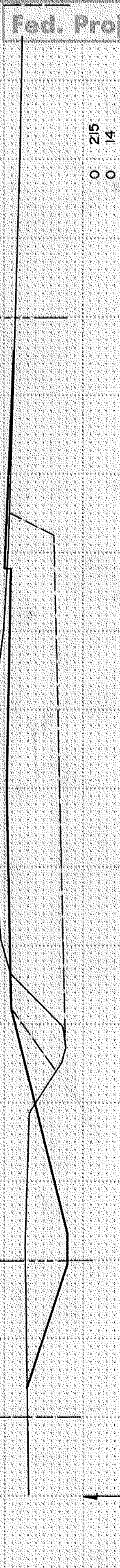

901.3 268+33 899.65  
EXISTING GRADE  
PROFILE GRADE  
(GRADING GRADE)

901.3 268+33 899.65

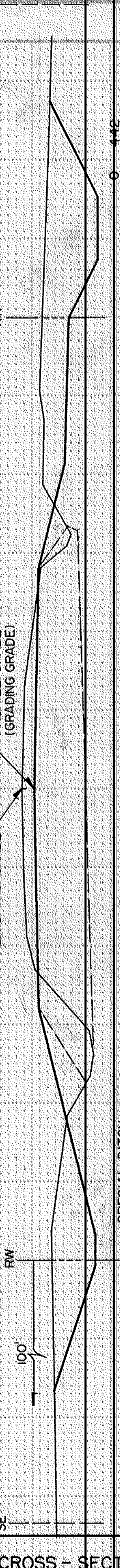

SPECIAL DITCH  
P.I. ELEV. 891.90

0 442  
0 68  
0 582

Fed. Proj. No.



**EXCAVATION EMBANKMENT**  
SUB-TOTALS CU.YDS. SUB-TOTALS CU.YDS.

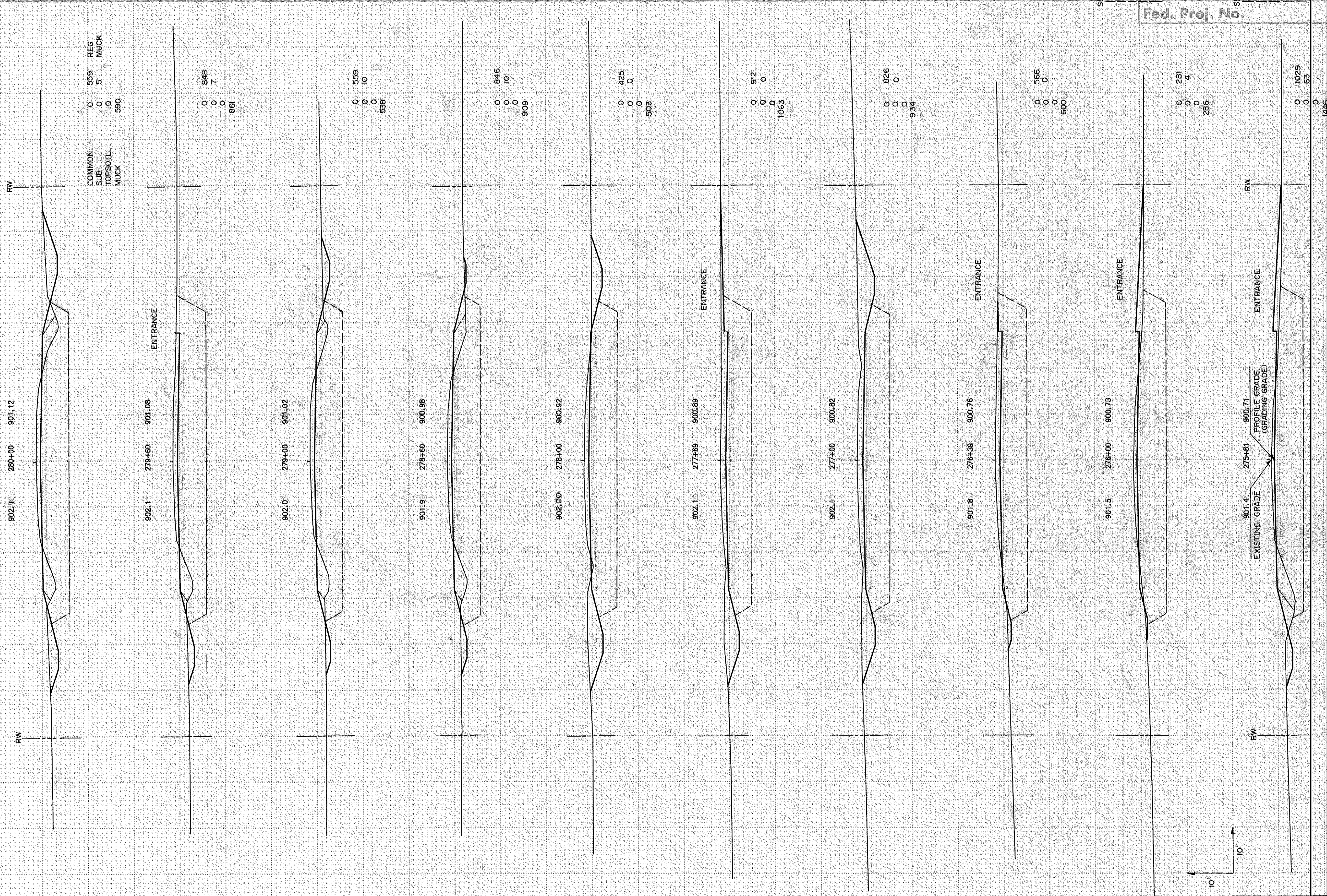

Fed. Proj. No.

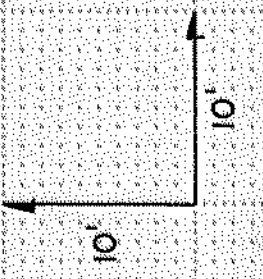

CROSS-SECTIONS  
STA. 275+81 TO STA. 280+00



**EXCAVATION EMBANKMENT**  
SUB-TOTALS CU.YDS. SUB-TOTALS CU.YDS.

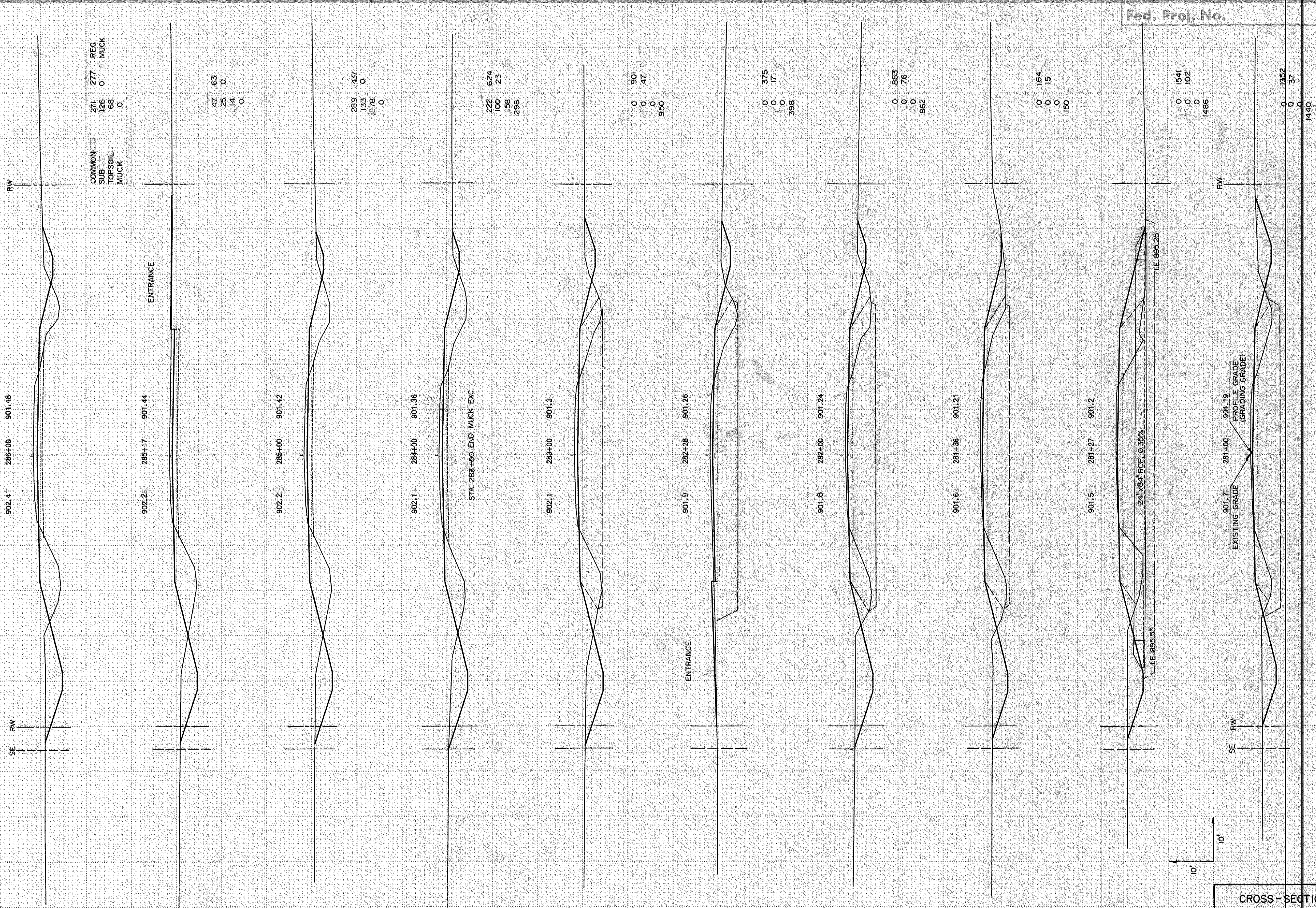

COMMON	271	277	REG
SUB	126	0	0
TOPSOIL	68	0	MUCK
MUCK	0		

47 63  
23 0  
14 0

289 437  
133 0  
78 0

222 624  
100 23  
58  
298

0 901  
0 47  
0  
950

0 375  
0 17  
0  
398

0 883  
0 76  
0  
862

0 164  
0 15  
0  
150

0 1541  
0 102  
0  
1486

0 1552  
0 37  
0  
1440

Fed. Proj. No.

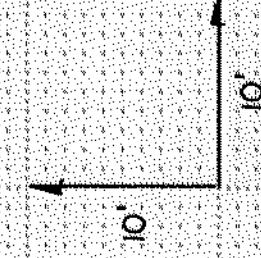

CROSS-SECTIONS  
STA. 281+00 TO STA. 286+00



902.6 293+70 902.6

902.7 293+00 902.72

COMMON	64	6	REG
SUB	52	0	MUCK
TOPSOIL	17		
MUCK		0	

END PROJECT  
292+25

902.7 292+00 901.84

252	181
194	0
63	0
	0

902.8 291+00 901.78

281	381
156	0
69	0
	0

902.4 290+00 901.72

361	396
131	0
72	0
	0

902.3 289+00 901.66

328	467
130	0
78	0
	0

902.2 288+00 901.6

311	465
133	0
80	0
	0

902.4 287+00 901.54

238	268
119	0
57	0
	0

71	65
32	0
	0

Fed. Proj. No.

RW

SE

ENTRANCE

RW

SE

ENTRANCE

EXISTING GRADE

PROFILE GRADE  
(GRADING GRADE)

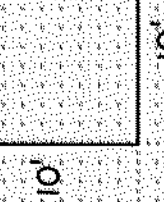



UNPAVED RESIDENTIAL AND FIELD ENTRANCES

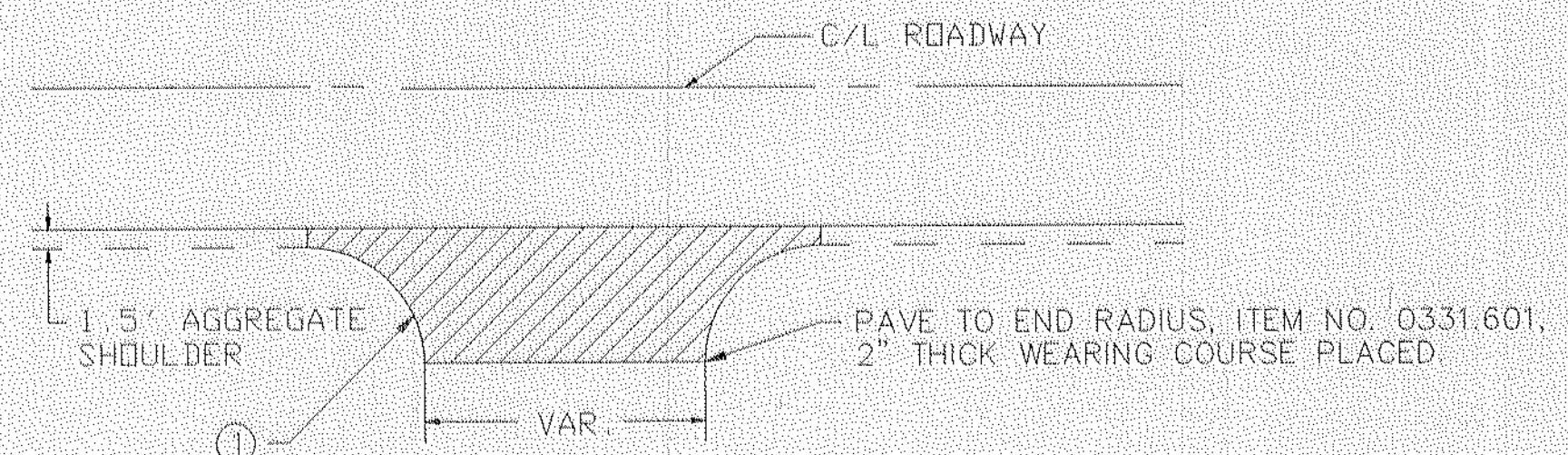

NOTE: COMMERCIAL AND RESIDENTIAL ENTRANCES WITH INPLACE BITUMINOUS SURFACING SHALL BE RESTORED WITH BITUMINOUS SURFACING, ITEM ON. 0331.601, 2" THICK WEARING COURSE PLACED.

- ① 20' RADIUS FOR RESIDENTIAL ENTRANCES.
- 25' RADIUS FOR COMMERCIAL ENTRANCES.

CENTERLINE CULVERT INSTALLATION

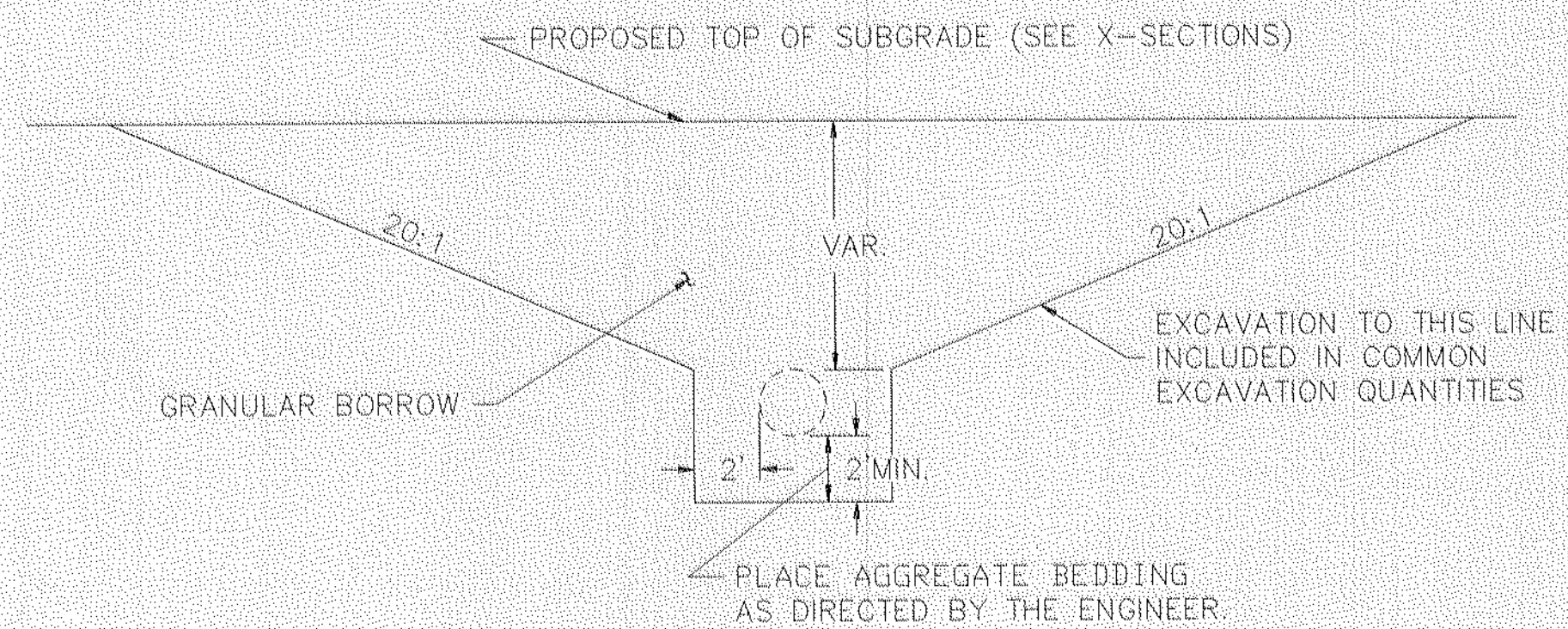

NOTES: \* FILL AND COMPACT GRANULAR TO 2" ABOVE FLOWLINE BEFORE PLACING CULVERT.  
 \* AT CENTERLINE CULVERT LOCATIONS CULVERT EXCAVATION TO EXTEND 3' BEYOND END OF APRON.  
 \* SEE CROSS SECTION AND PROFILE SHEETS FOR DEPTH AND LIMITS OF CULVERT EXCAVATION.

RIPRAP AT CMP OUTLETS  
 (SEE CULVERT TABULATION CHART FOR LOCATIONS)

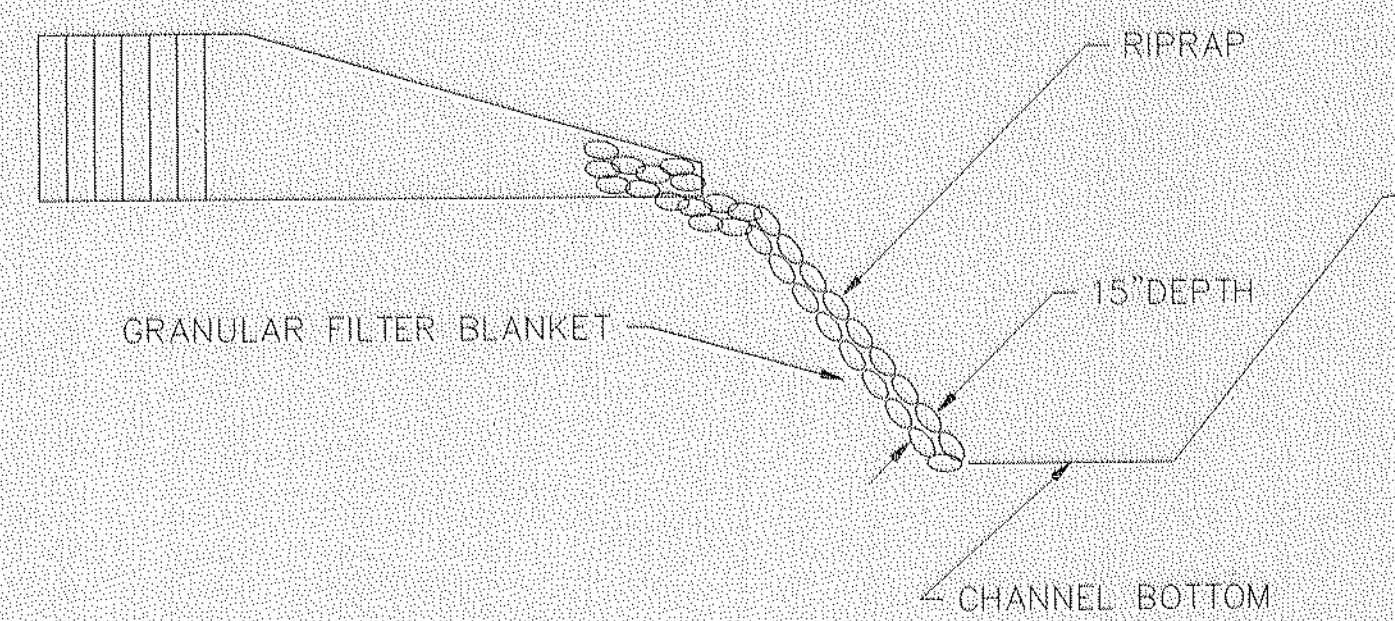
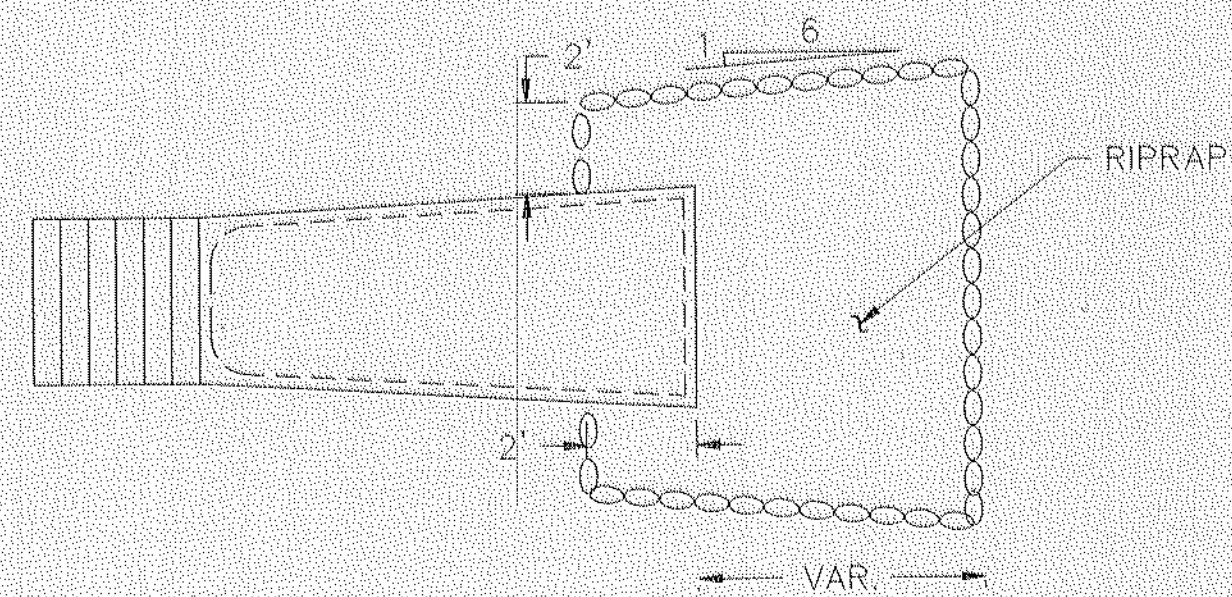

REVISIONS	DATE	BY

STANDARD DETAILS  
 RESIDENTIAL AND STREET ENTRANCES  
 CENTERLINE CULVERT INSTALLATION  
 RIPRAP AT CMP OUTLETS



BALE HAY OR STRAW DITCH CHECK

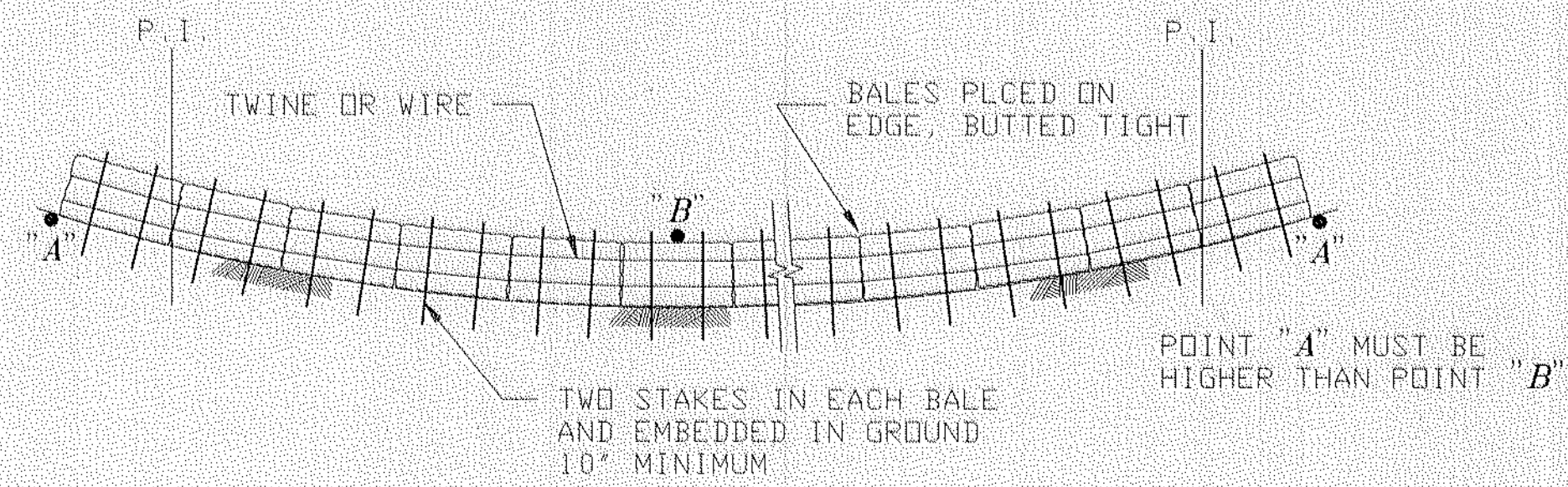

SILT FENCE DETAIL

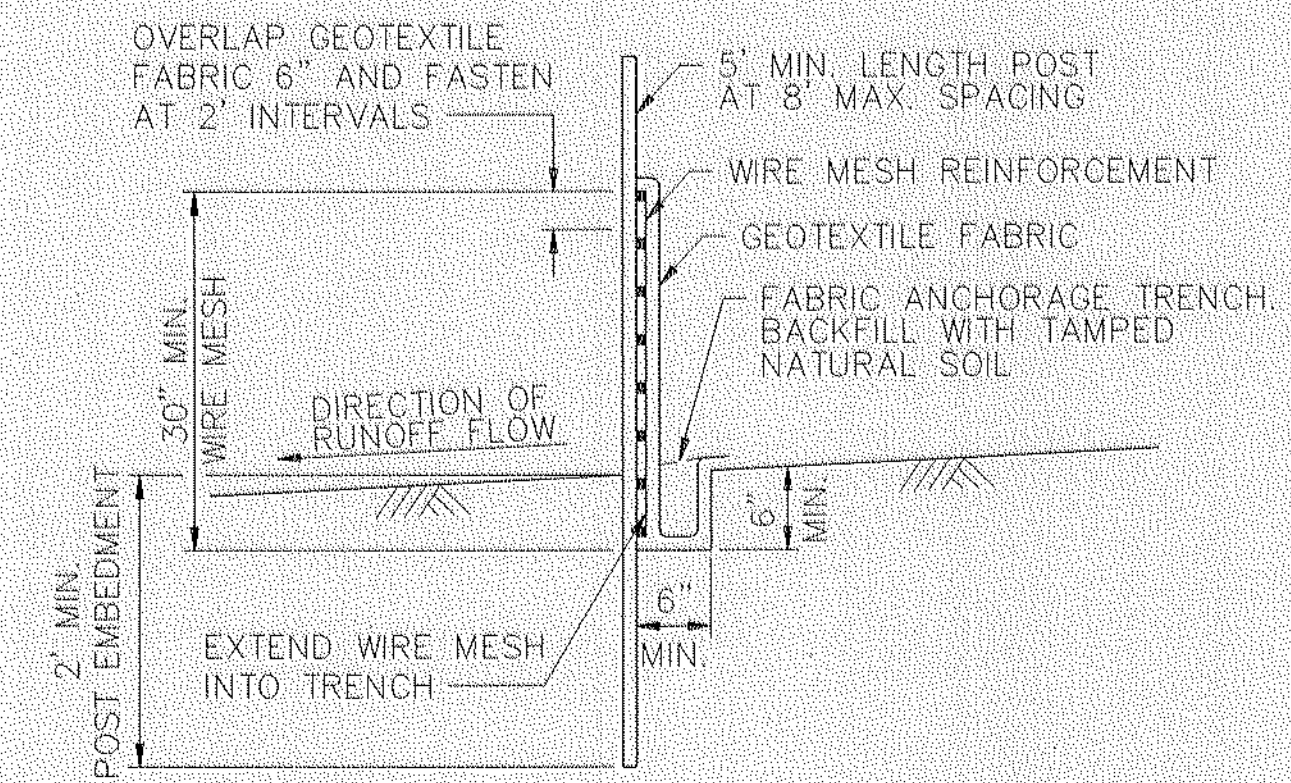

ALTERNATE BALE CHECK

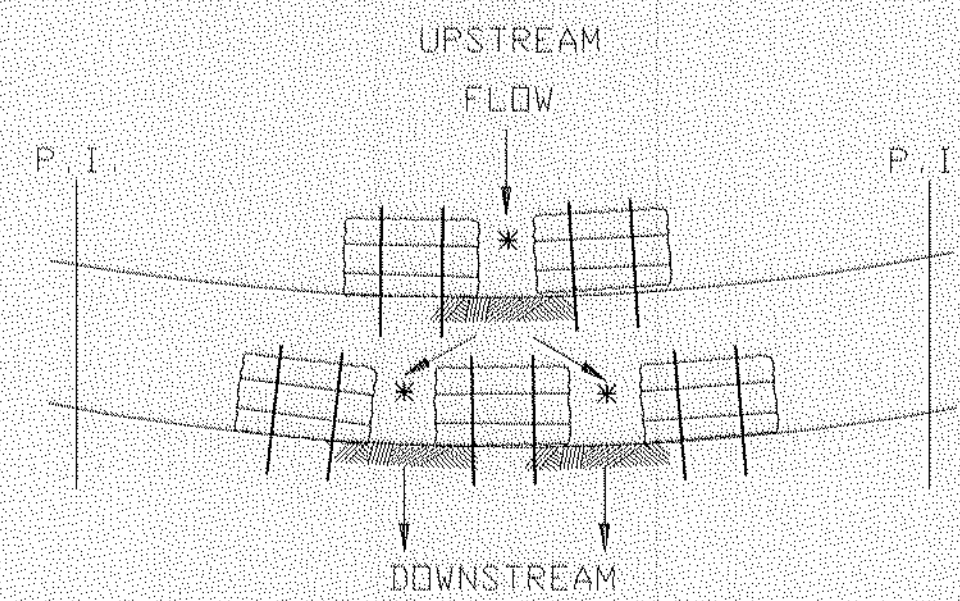

NOTES: PLACEMENT OF BALES WILL BE DETERMINED BY THE ENGINEER IN THE FIELD.

WHEN USING THE ALTERNATE BALE CHECK, THE TWIN BALES WILL BE ON THE UPSTREAM SIDE.

\* THE DISTANCE BETWEEN BALES SHALL BE 1 FT. (TYP.)

DITCH CHECK SECTIONS

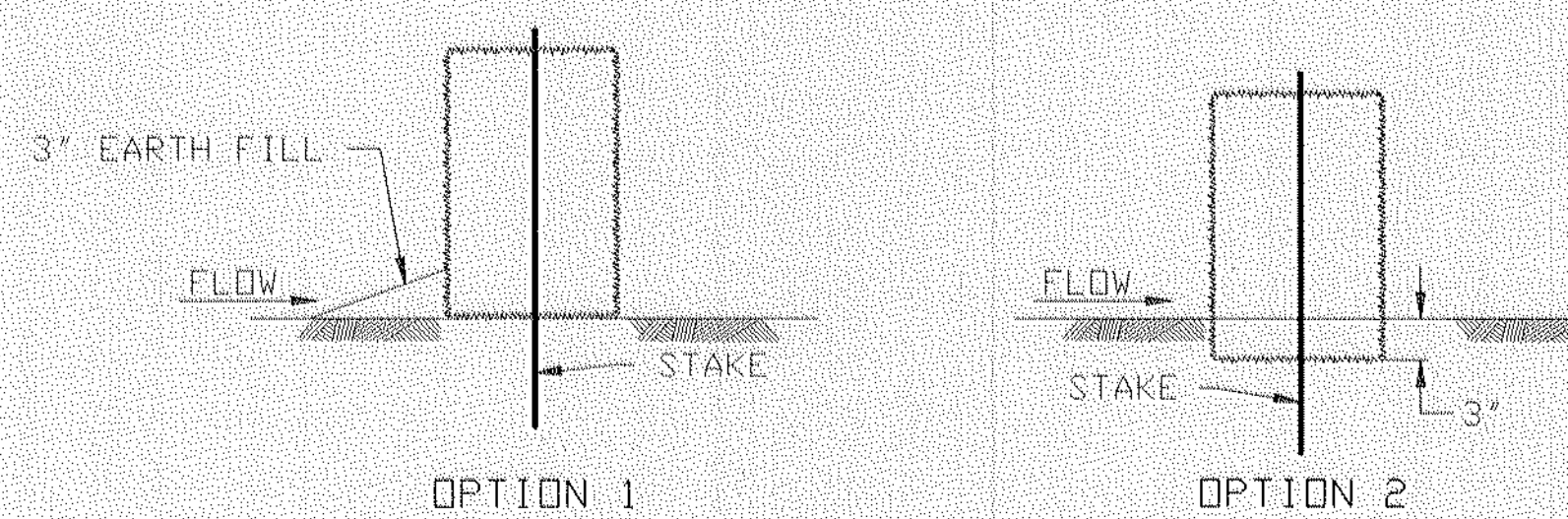

REVISIONS	DATE	BY



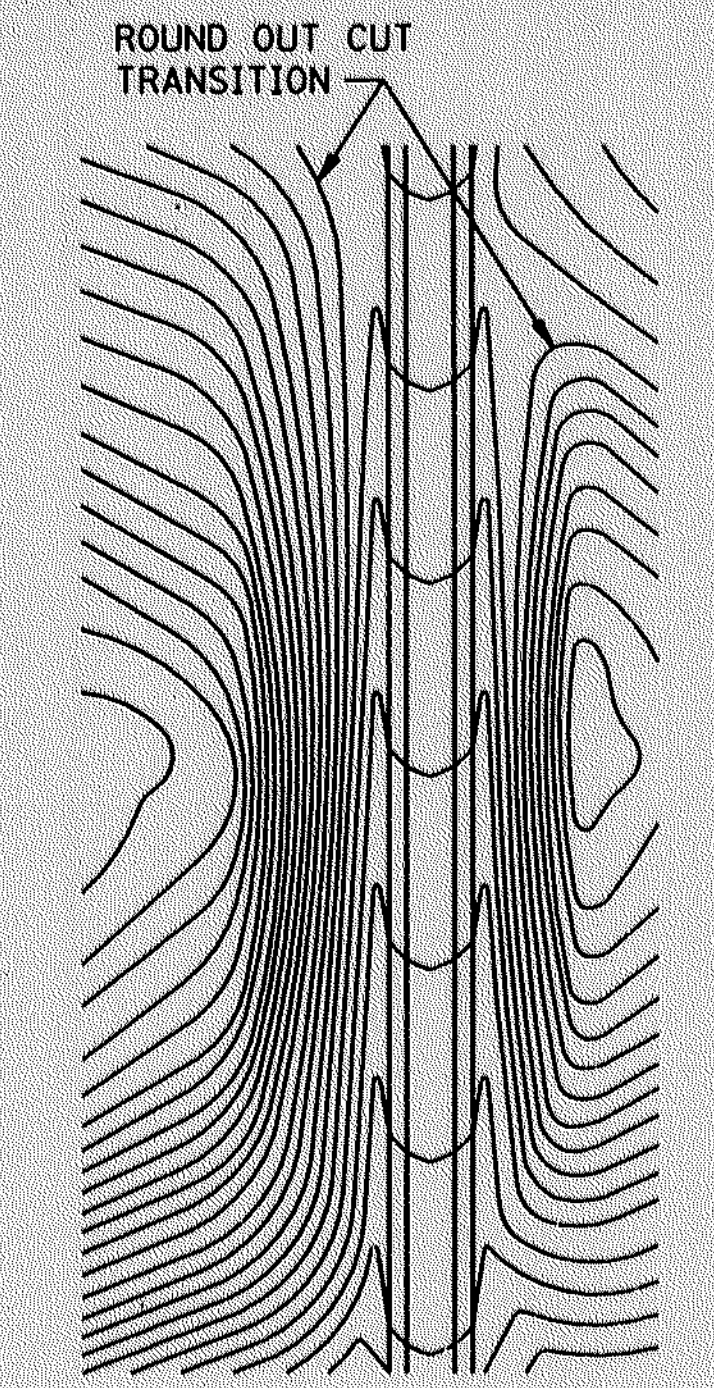

CONTOURING ROAD CUTS

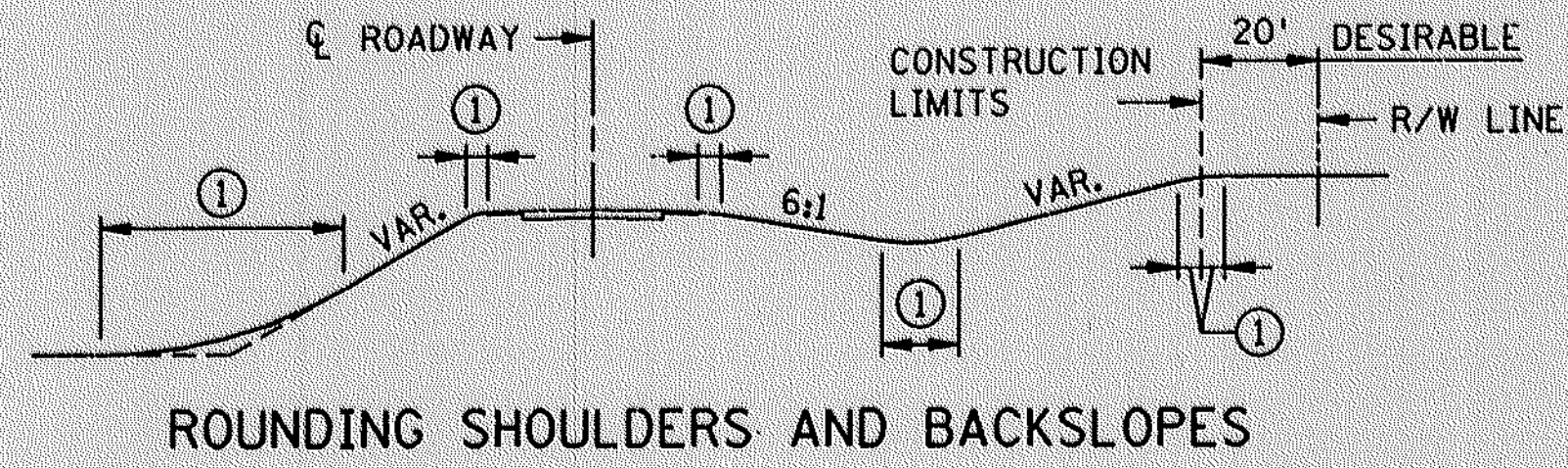

ROUNDING SHOULDERS AND BACKSLOPES

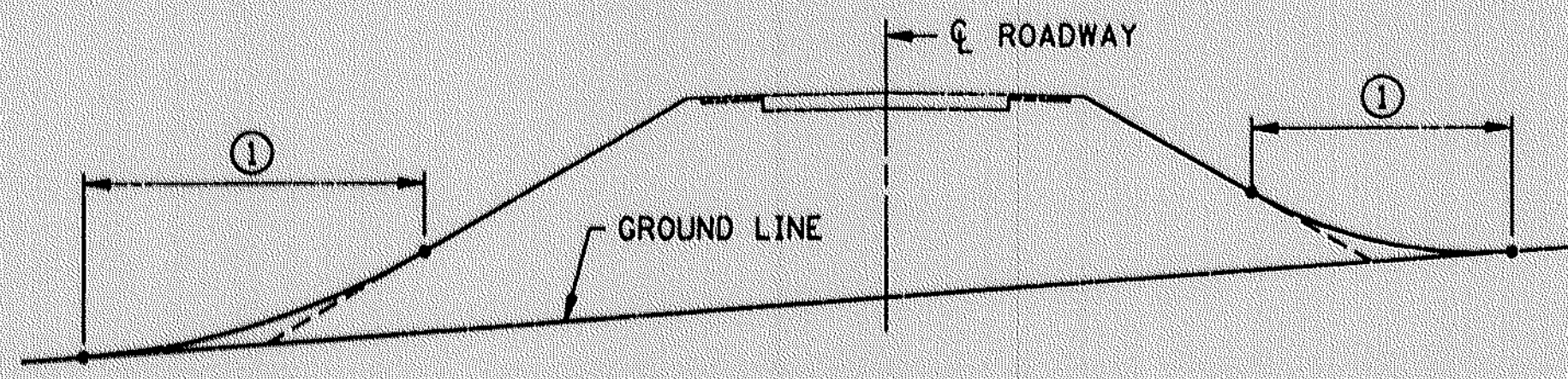

SHAPING FOR DRAINAGE ALONG THE TOE OF FILL SLOPES

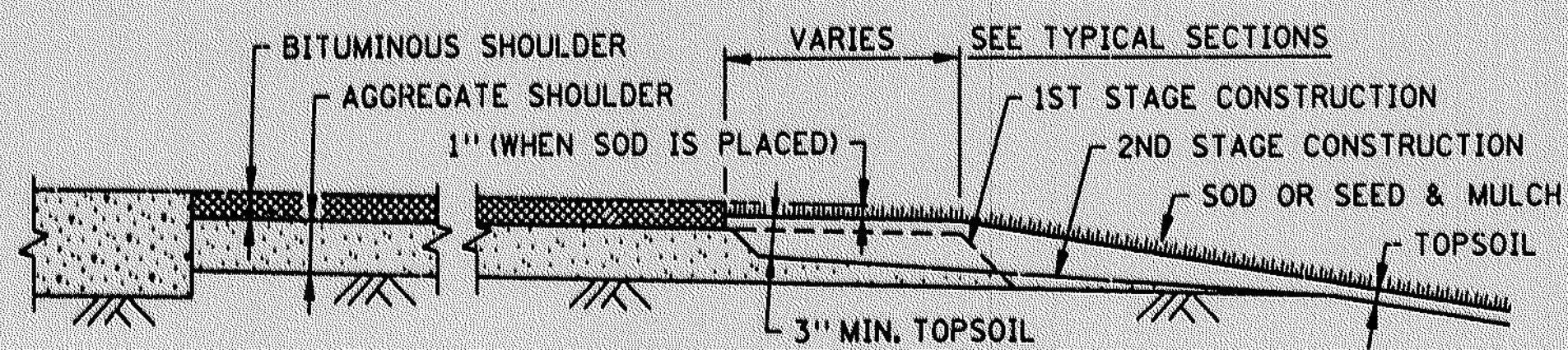

SHAPING AND TOPSOILING INSLOPES

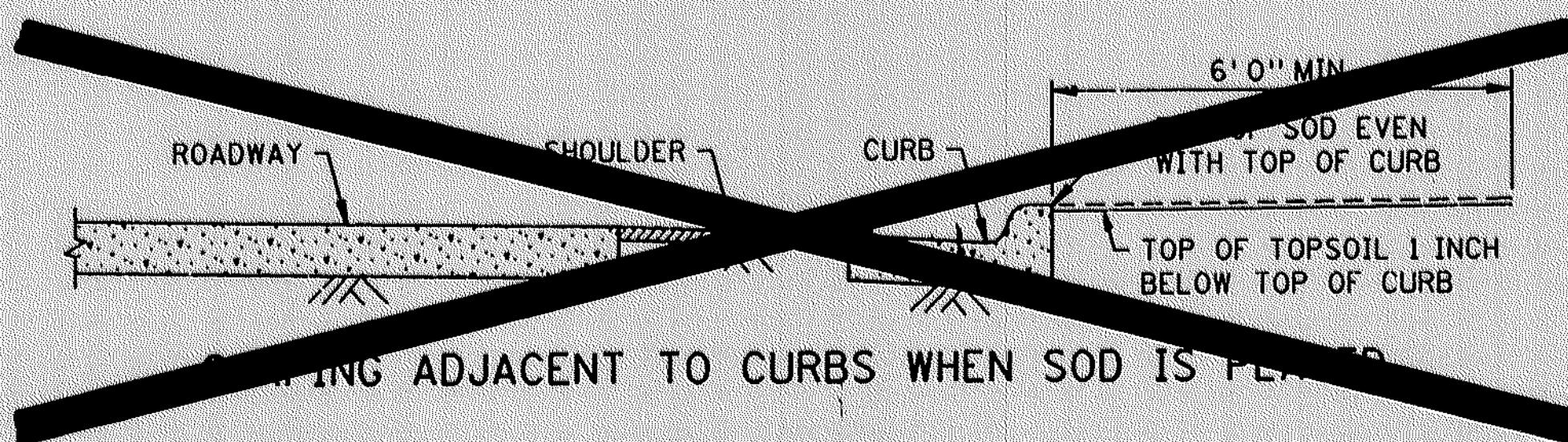

SHAPING ADJACENT TO CURBS WHEN SOD IS PLACED

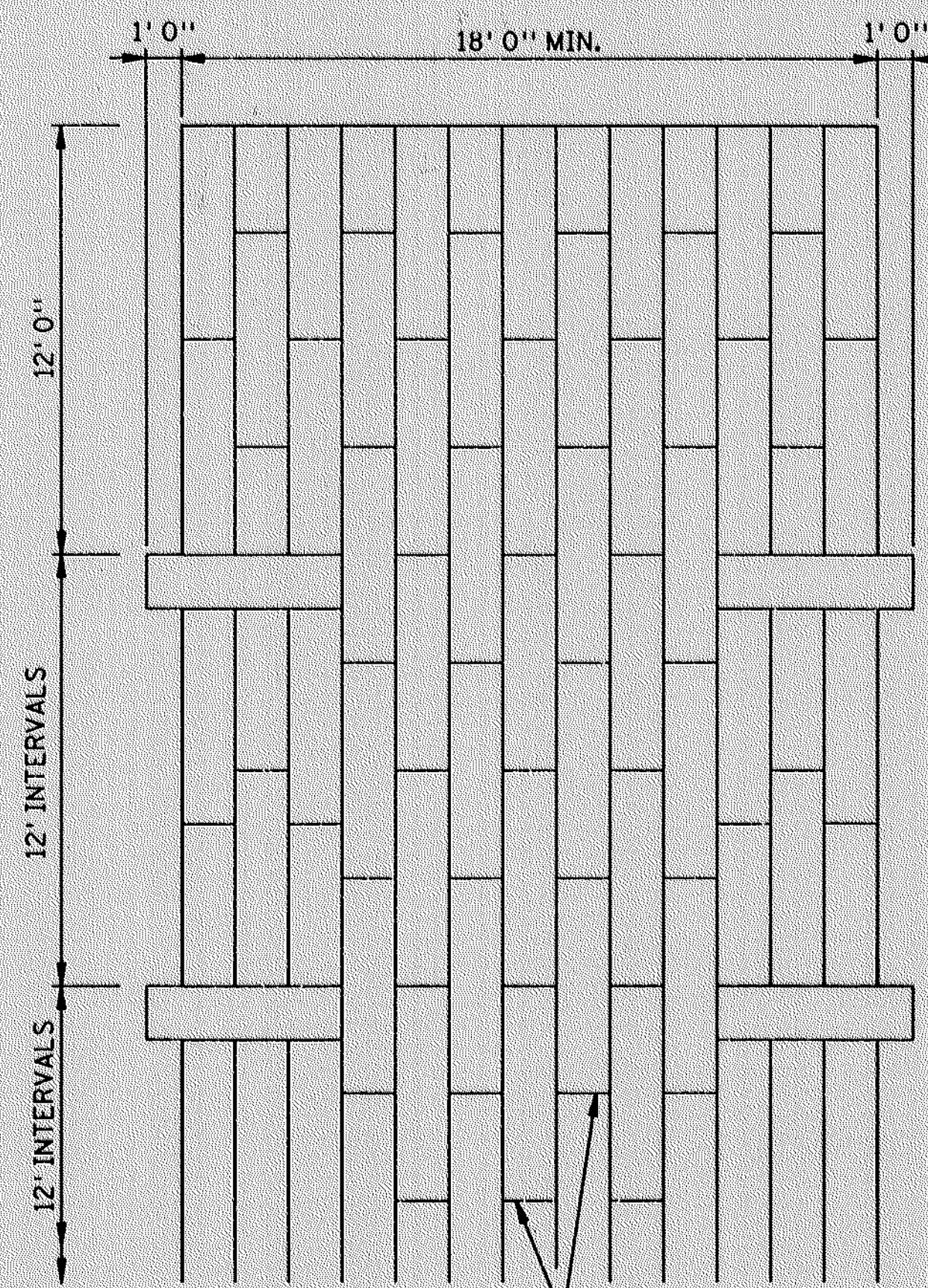

STAGGER JOINTS  
PLAN VIEW

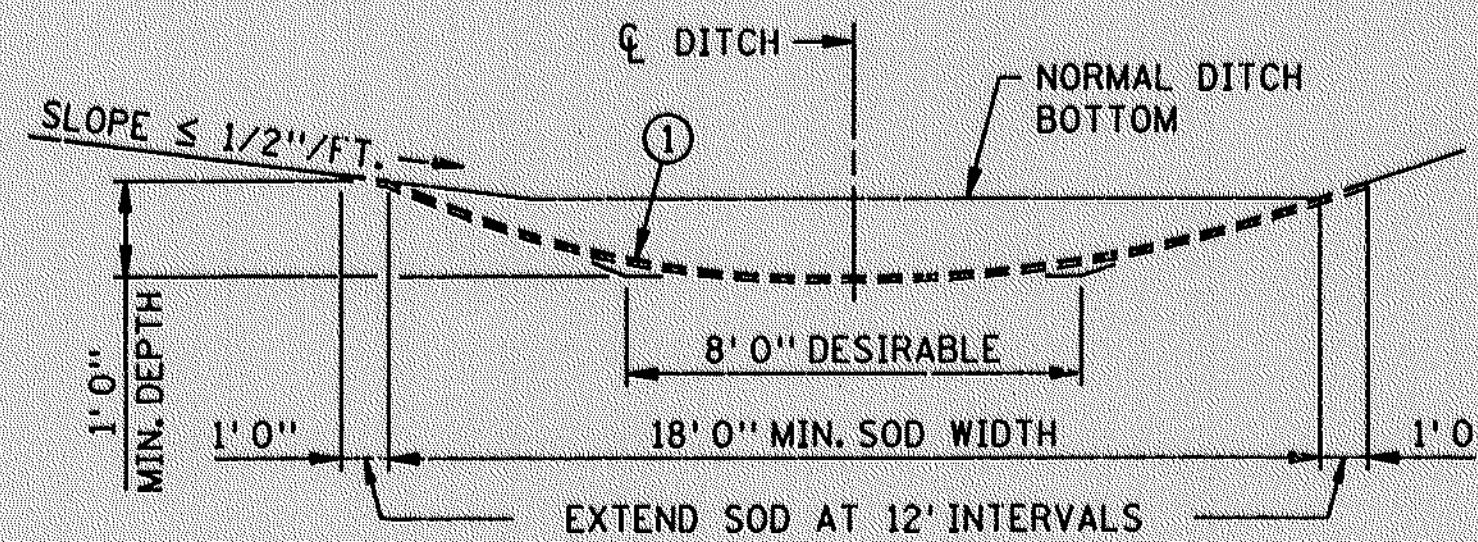

SODDED DITCH CROSS SECTION  
WHERE FRONT OR BACK SLOPE IS FLAT (LESS THAN 1/2\"/>

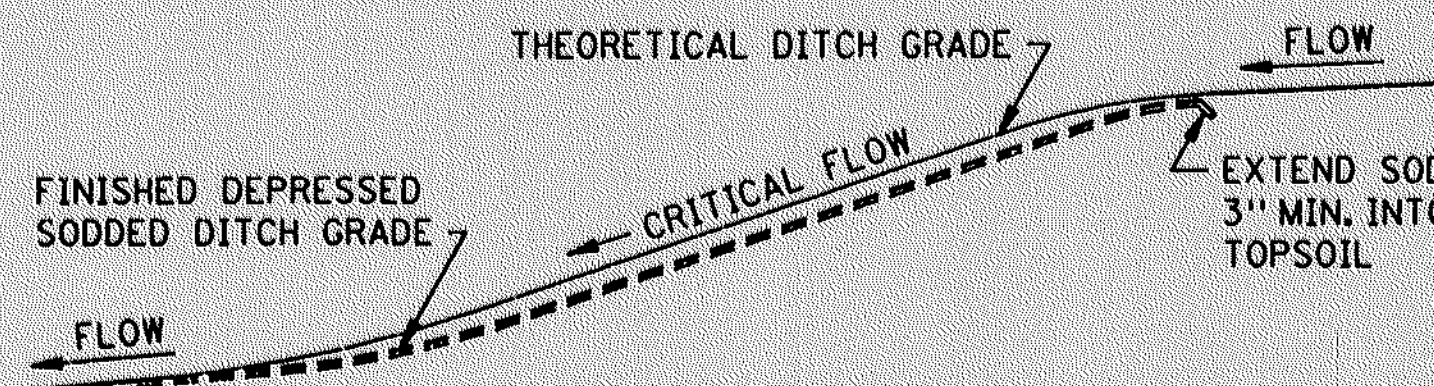

DITCH PROFILE  
SODDED DITCH DETAILS

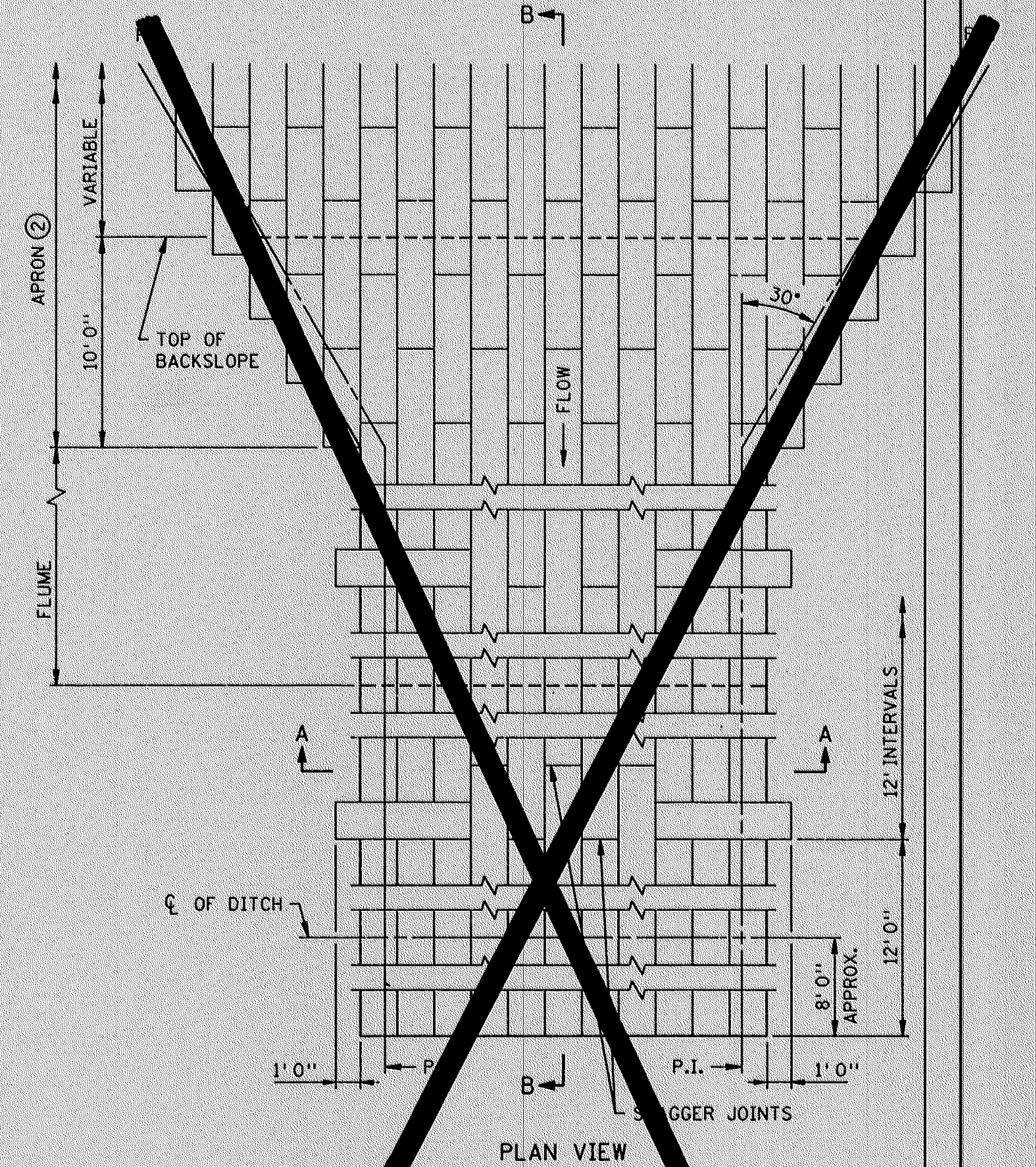

PLAN VIEW

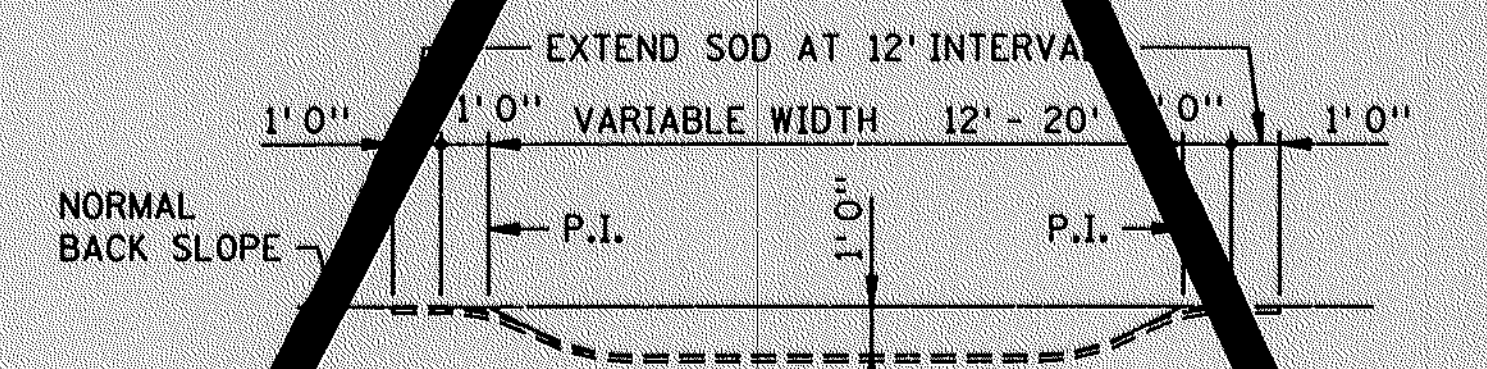

SECTION A-A

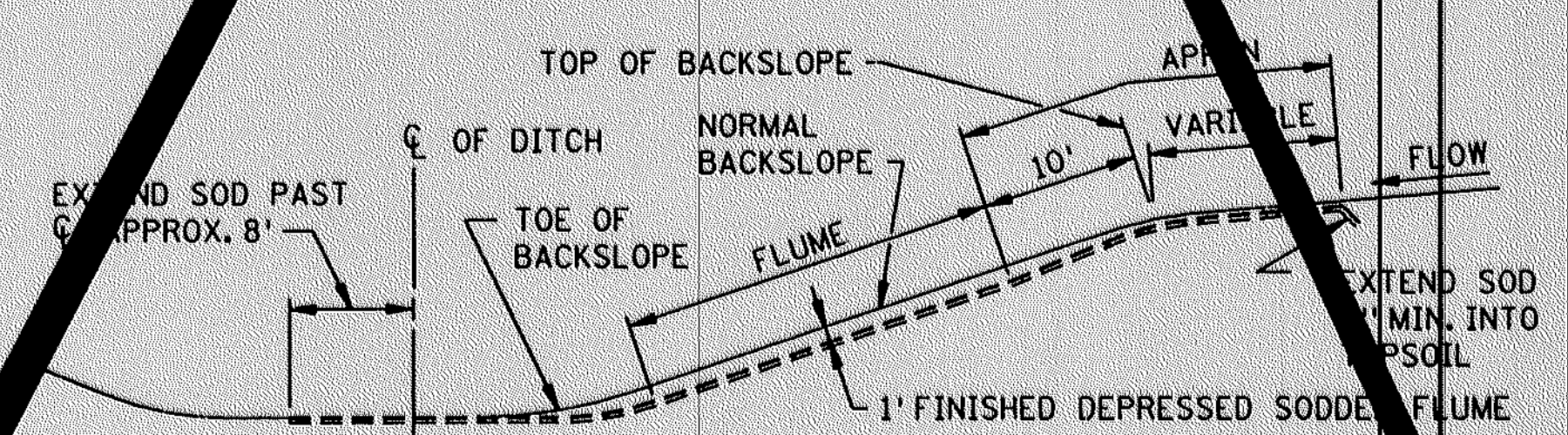

SECTION B-B  
SODDED FLUME DETAILS

- NOTES:  
 SEE SPEC. 2575.3 FOR ADDITIONAL INFORMATION.  
 ① FOR ROUNDING, SEE ROAD DESIGN MANUAL.  
 ② CONSTRUCT TAPER AS DIRECTED BY THE ENGINEER.

STANDARD SHEET NO. 5-297.404	TITLE: PERMANENT EROSION CONTROL ALONG ROADWAYS, DITCHES AND FLUMES
STANDARD APPROVED: DECEMBER 19, 1990	
STATE PROJ. NO. S.A.P. 02-614-15	SHEET NO. 9 OF 41 SHEETS



EXCAVATION PLAN

FINISHED LANDSCAPING PLAN

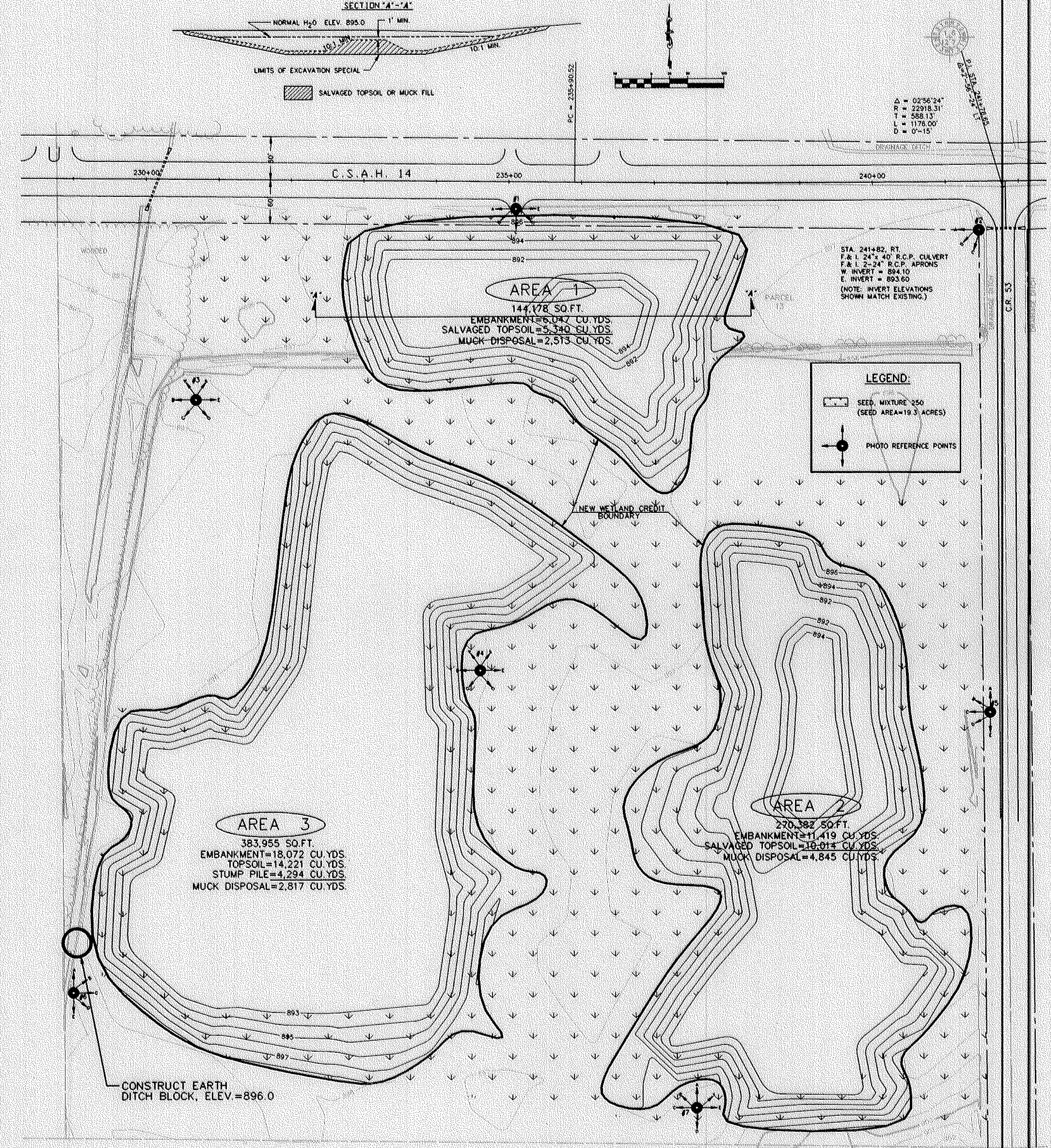
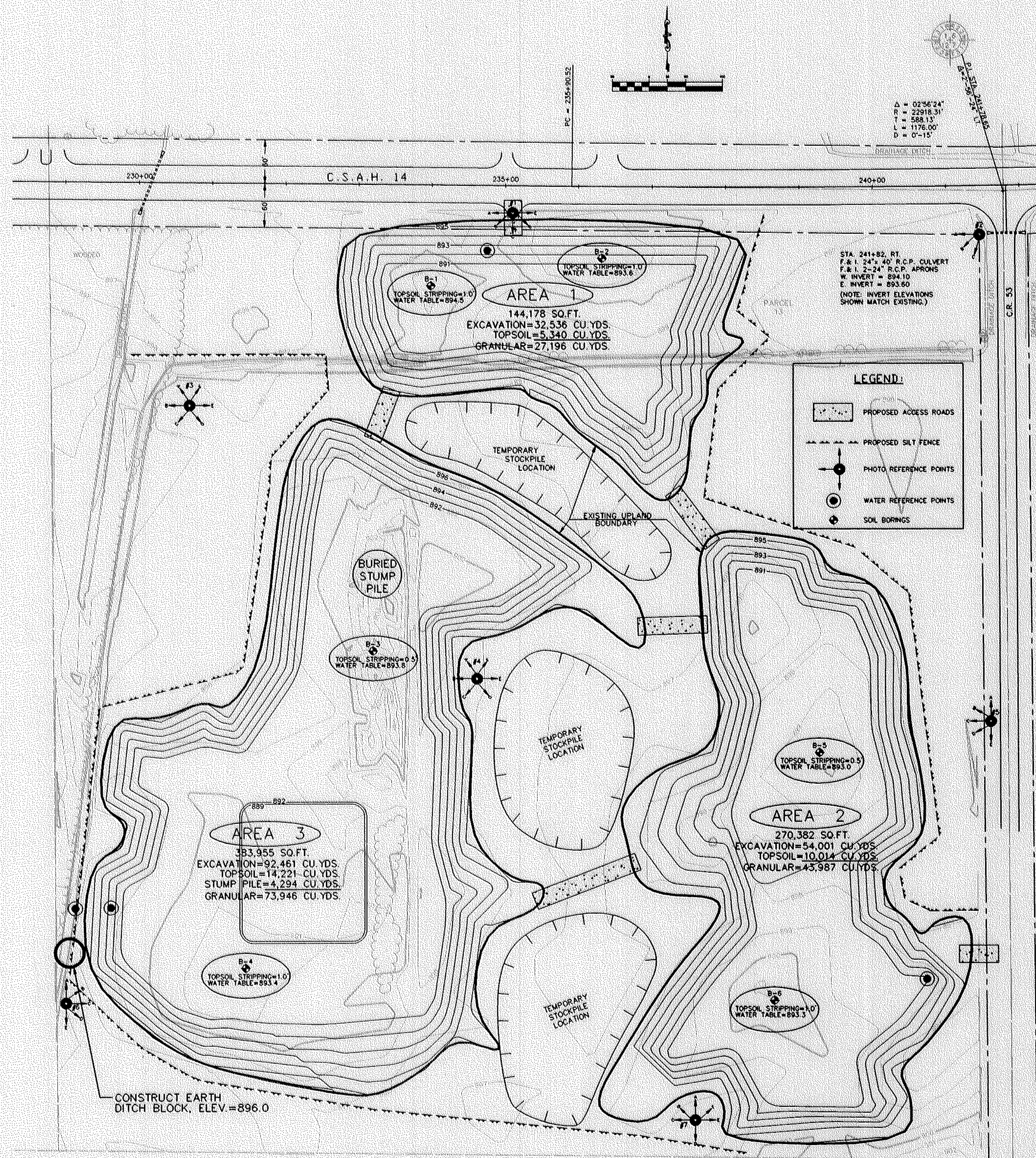

**SITE INFORMATION**

EXCAVATION SPECIAL	174,704 CU. YDS.	TOPSOIL	29,575 CU. YDS.
GRANULAR	145,129 CU. YDS.		

\* BASED ON AN AVERAGE TOPSOIL DEPTH OF 1.0'

**MUCK DISPOSAL COMPUTATION**

MUCK EXCAVATION/COMPACTION (EV TO CV), 60% SHRINKAGE  
 TOPSOIL EXCAVATION/COMPACTION (EV TO CV), 85% SHRINKAGE

TOTAL MUCK DISPOSAL (EV) = [TOTAL EMBANKMENT - (SALVAGED TOPSOIL × 0.85) - STUMP PILE DISPOSAL] / 0.60  
 = [35,938 - (29,575 × 0.85) - 4,294]  
 = 10,175 CU. YDS.

REVISIONS



NO.	DATE	BY



EXISTING WETLAND TYPES

LEGEND

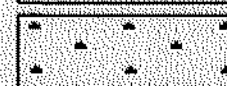
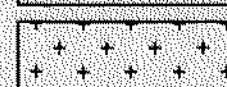
PROPOSED WETLAND TYPES

-  TYPE 1 WETLAND
-  TYPE 2 WETLAND
-  TYPE 3 WETLAND
-  FIELD STAKED WETLAND BOUNDARY

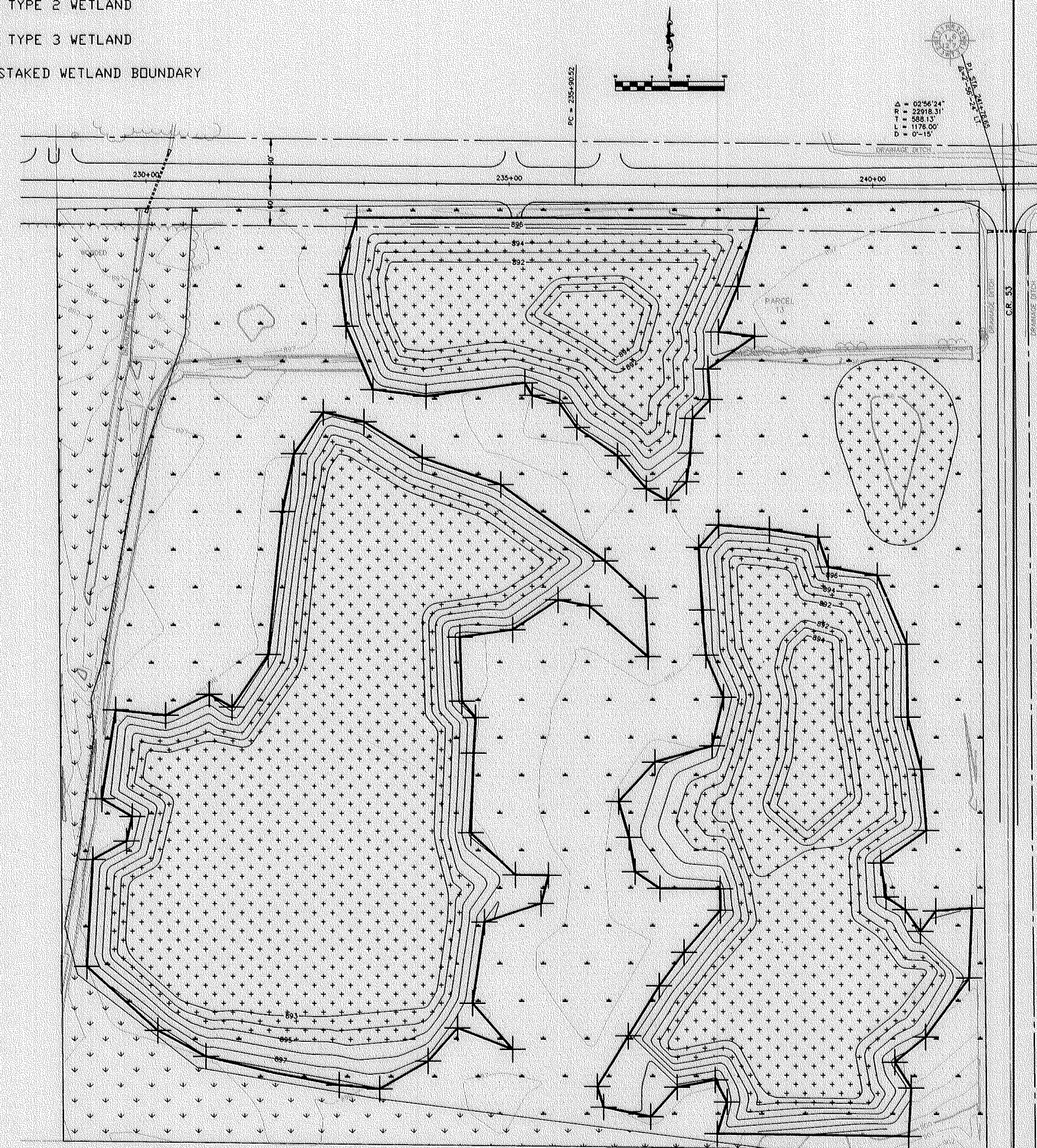
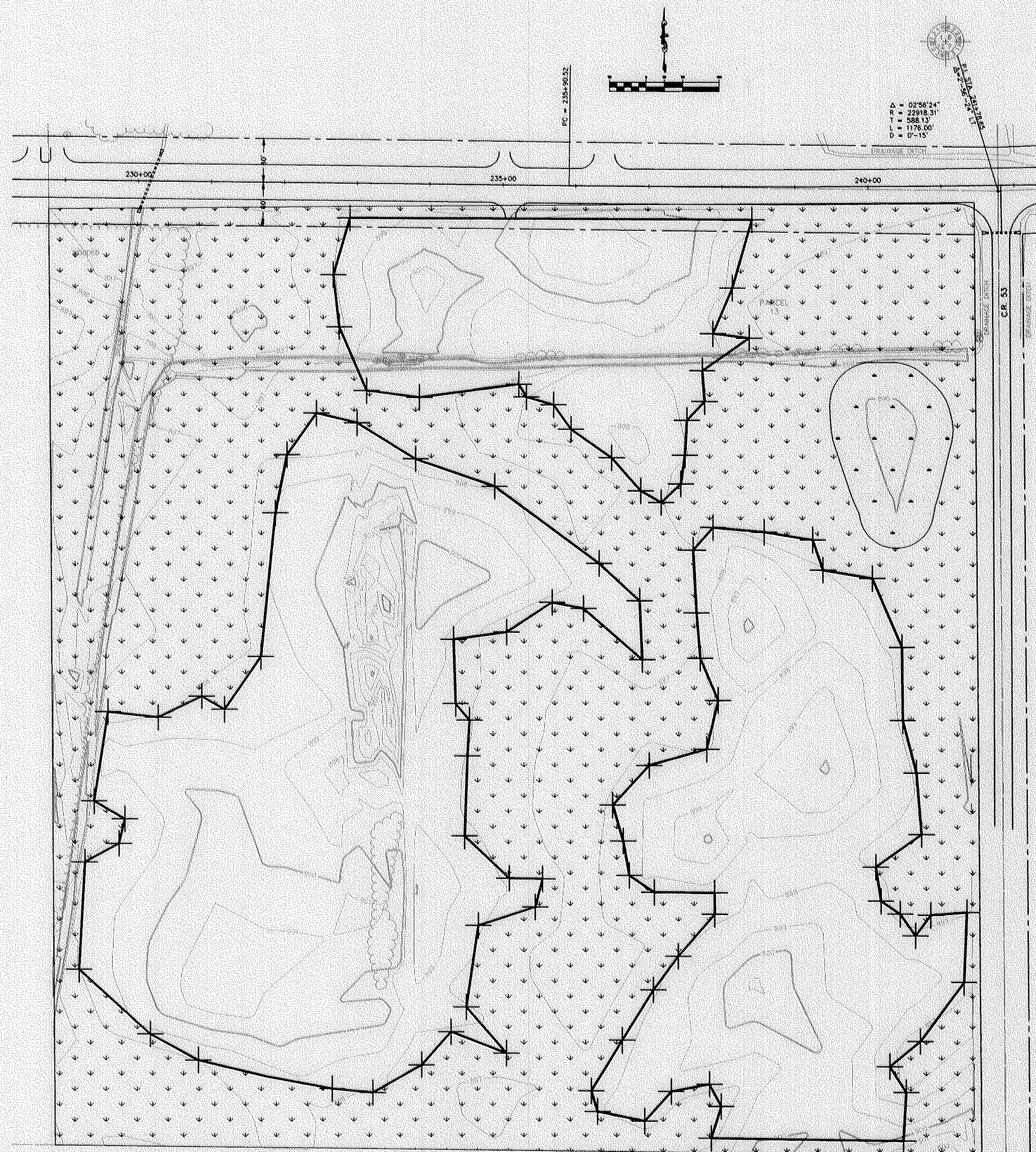

REVISIONS	DATE	BY



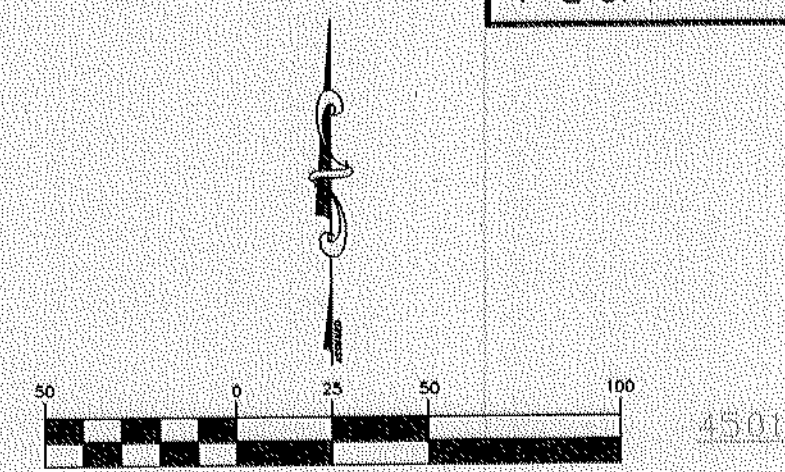

STA. 201+00 C/L CULVERT  
 F. & I. 24'x 72' R.C.P. CULVERT  
 F. & I. 2 - 24' R.C.P. APRONS  
 INVERT ELEV. LT. = 900.40  
 INVERT ELEV. RT. = 900.70

STA. 203+57 C/L CULVERT  
 INPL. 18'x 56' C.M.P.  
 REMOVE  
 NO CULVERT REQUIRED

LWB PI = 197+97.59  
 D = 0° 30'  
 Δ = 01° 41' 33"  
 R = 11459.16'  
 T = 169.25'  
 L = 338.48'

LEB PI = 197+97.59  
 D = 0° 30'  
 Δ = 01° 41' 33"  
 R = 11459.16'  
 T = 169.25'  
 L = 338.48'

PT = 199+66.82  
 A PT. 12' LT & L  
 TO Q. STA. 199+66.72

PT = 199+66.82  
 A PT. 12' RT & L  
 TO Q. STA. 199+66.72

BEGIN S.A.P. 02-614-15  
 STATION 199+67.00

PARCEL 1  
 HD 4351

PARCEL 2

PARCEL 8

PARCEL 2

PARCEL 3

PARCEL 4

PARCEL 5

P.I. STA. 215+75.16  
 Δ = 0° 00' 01" LT

HD 4811

HD 4601

LEVER ST. N.E.

C.S.A.H. 14

- PARCEL 8 SEED MIXTURE 700, TYPE 1 MULCH
- SEED MIXTURE 650, TYPE 5 MULCH
- SODDING, TYPE LAWN AND BOULEVARD

PARCEL 9

PARCEL 10

PARCEL 11

PARCEL 12

TURF ESTABLISHMENT

14VIEW.DWG (TILEMODE) MN.

REVISIONS	DATE	BY	BY



STA. 230+16 C/L CULVERT  
 INPL. 24' x 44' C.M.P.  
 REMOVE  
 F & I. 24' x 80' R.C.P. CULVERT  
 F & I. 2 - 24' R.C.P. APRONS  
 INVERT ELEV. LT. (+30) = 895.90  
 INVERT ELEV. RT. (+00) = 895.40

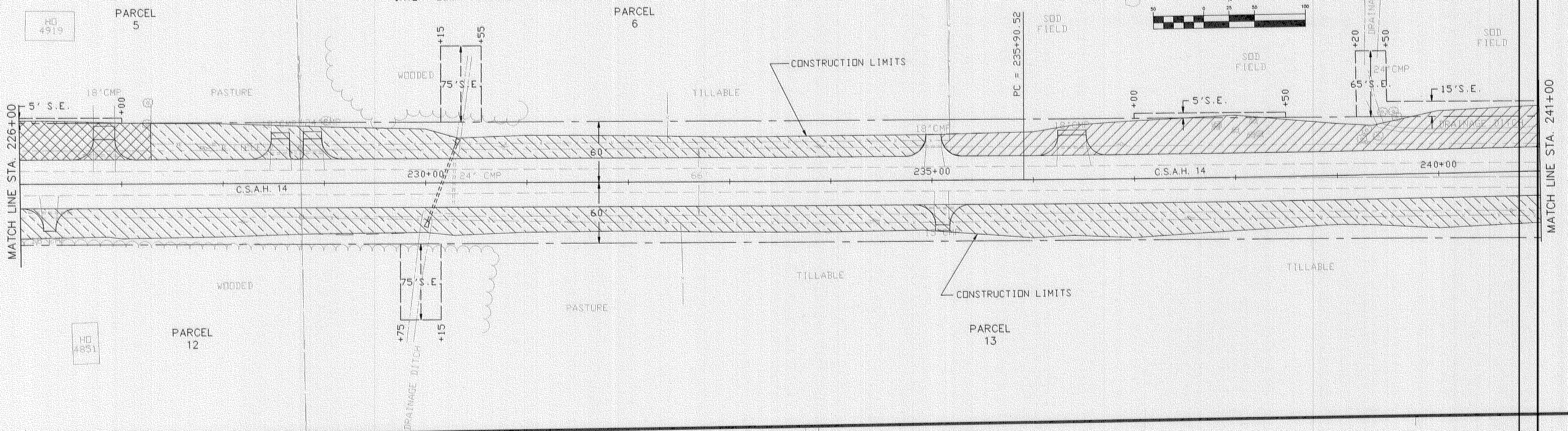

STA. 249+80 C/L CULVERT  
 INPL. 18' x 52' R.C.P.  
 REMOVE  
 NO CULVERT REQUIRED

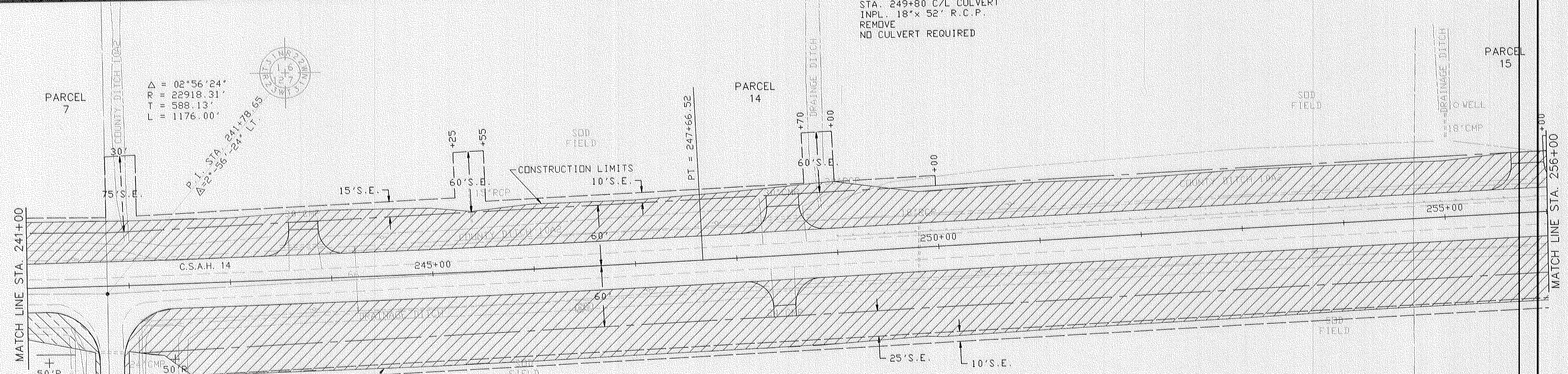

$\Delta = 02^{\circ}56'24''$   
 $R = 22918.31'$   
 $T = 588.13'$   
 $L = 1176.00'$

P.I. STA. 241+78.65  
 $\Delta = 2^{\circ}56'24''$  LT.

REVISIONS	DATE	BY

- SEED MIXTURE 700, TYPE 1 MULCH
- SEED MIXTURE 650, TYPE 5 MULCH
- SODDING, TYPE LAWN AND BOULEVARD

TURF ESTABLISHMENT



STA. 268+19 C/L CULVERT  
 INPL. 60'x 72' C.M.P.  
 REMOVE  
 F. & I. 60'x 86' R.C.P. CULVERT  
 F. & I. 2 - 60' R.C.P. APRONS  
 INVERT ELEV. LT. (+25) = 890.90  
 INVERT ELEV. RT. (+13) = 890.60

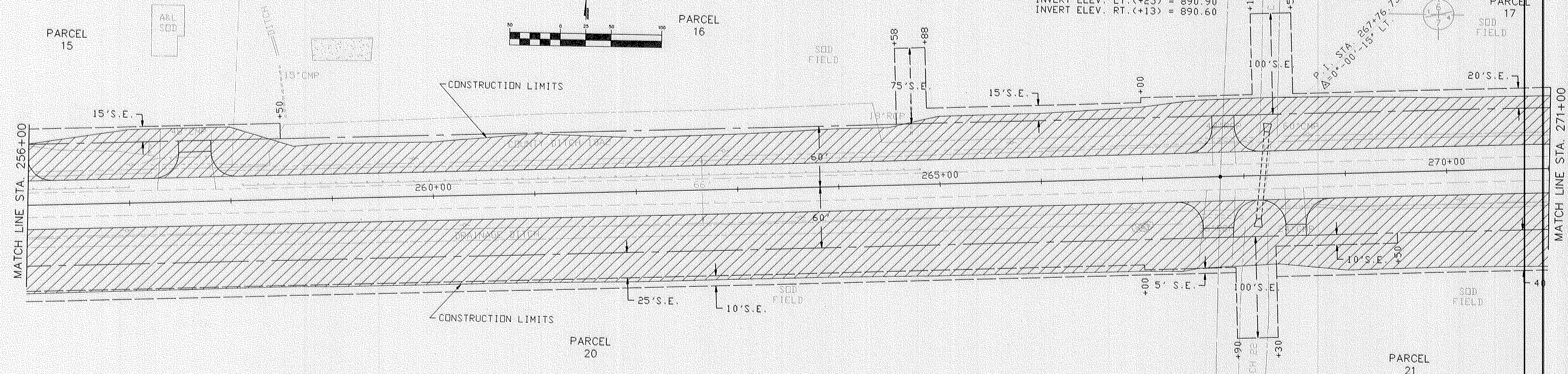
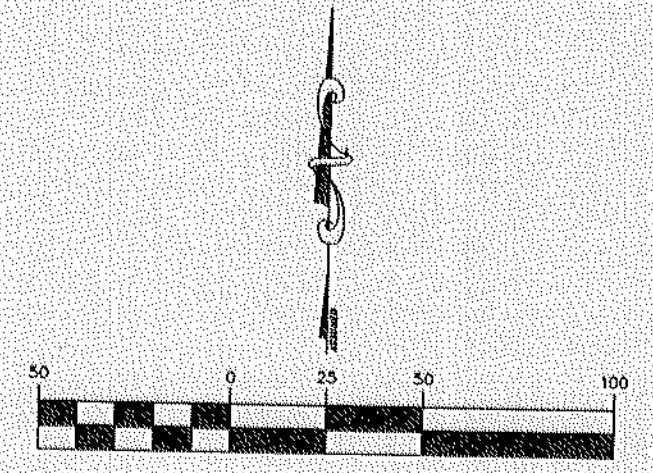

STA. 281+22 C/L CULVERT  
 INPL. 24'x 46' R.C.P.  
 REMOVE  
 F. & I. 24'x 84' R.C.P. CULVERT  
 F. & I. 2 - 24' R.C.P. APRONS  
 INVERT ELEV. LT. = 895.55  
 INVERT ELEV. RT. = 895.25

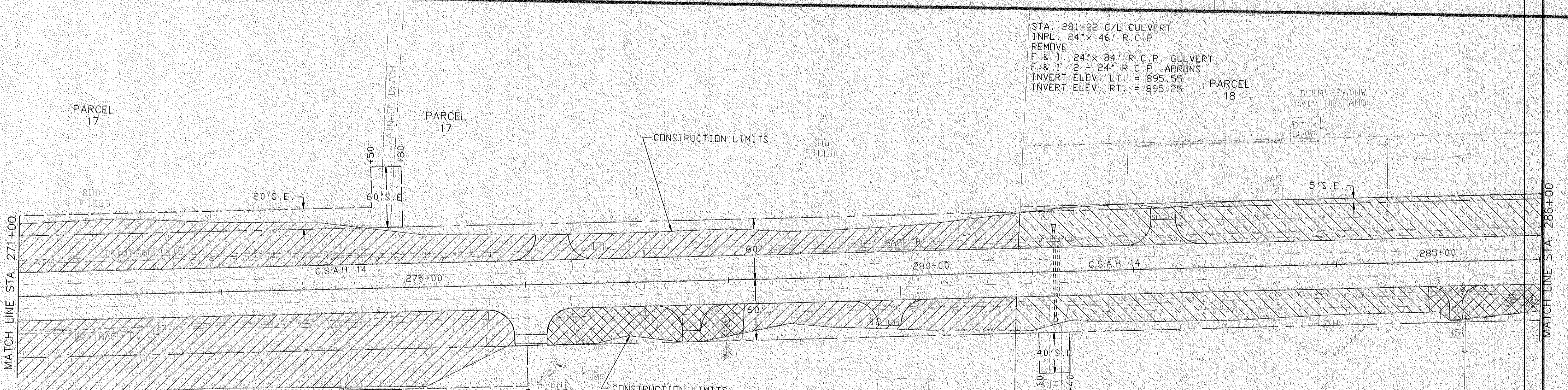

- SEED MIXTURE 700, TYPE 1 MULCH
- SEED MIXTURE 650, TYPE 5 MULCH
- SODDING, TYPE LAWN AND BOULEVARD

REVISIONS	DATE	BY

TURF ESTABLISHMENT



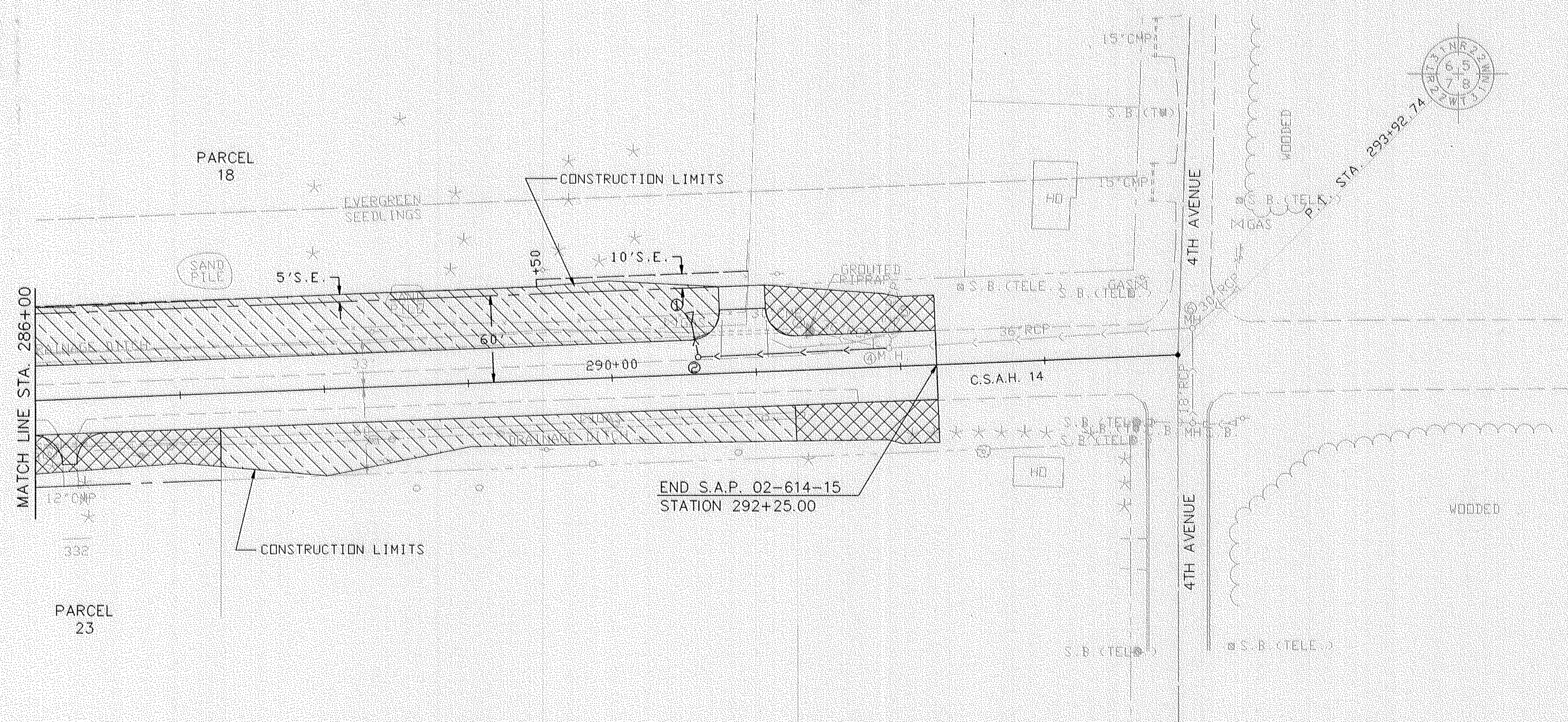

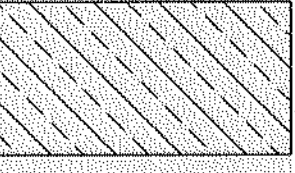
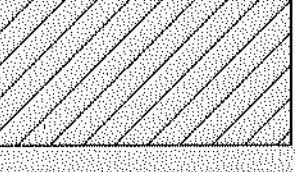
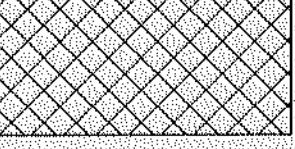
-  SEED MIXTURE 700, TYPE 1 MULCH
-  SEED MIXTURE 650, TYPE 5 MULCH
-  SODDING, TYPE LAWN AND BOULEVARD

REVISIONS		
DATE	BY	BY

TURF ESTABLISHMENT



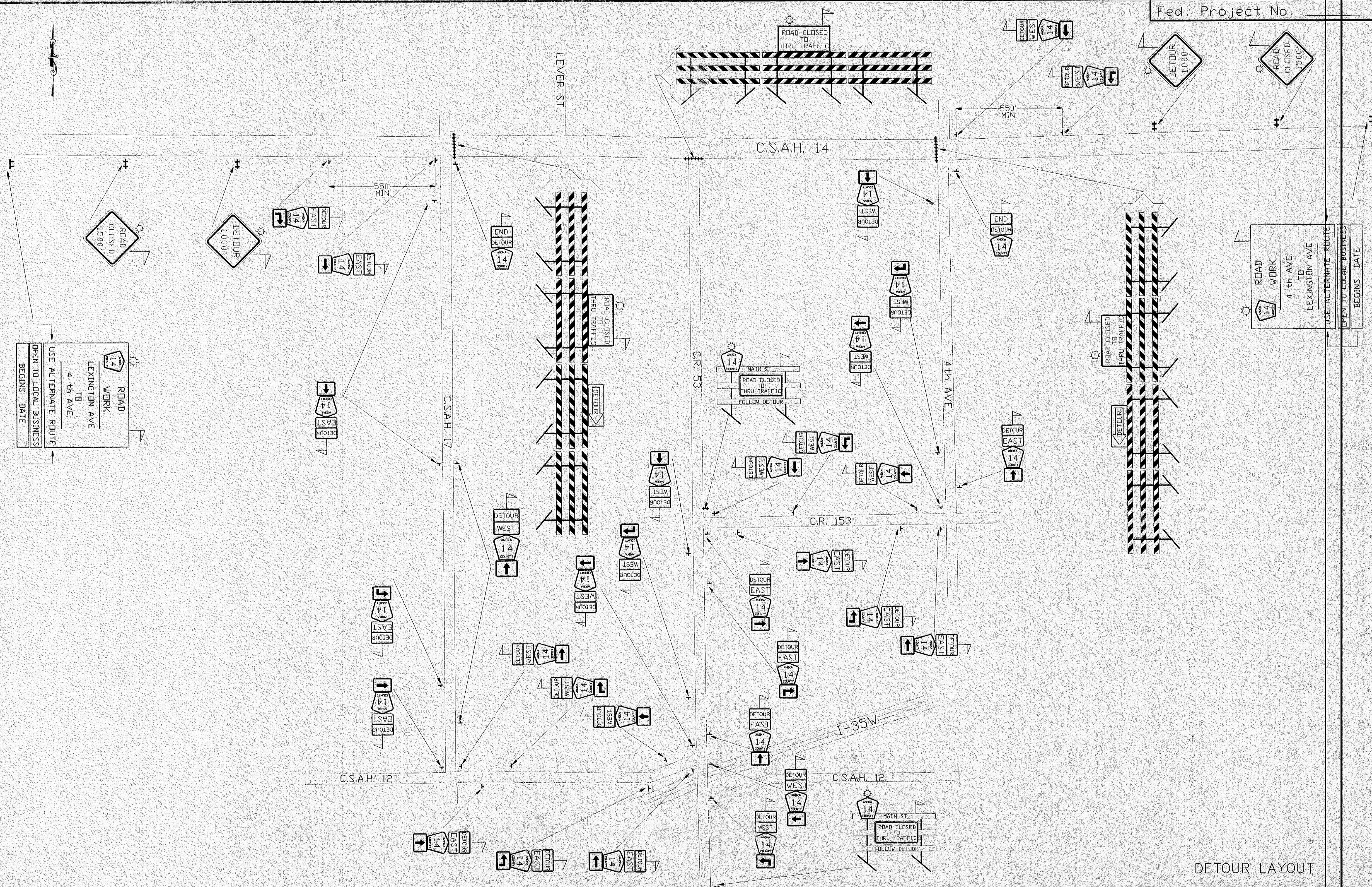

ROAD WORK  
4th AVE.  
TO  
LEXINGTON AVE  
USE ALTERNATE ROUTE  
OPEN TO LOCAL BUSINESS  
BEGINS DATE

ROAD WORK  
LEXINGTON AVE  
TO  
4th AVE  
USE ALTERNATE ROUTE  
OPEN TO LOCAL BUSINESS  
BEGINS DATE

DETOUR LAYOUT



M.U.T.C.D. CODE	SIZE	INSERT	QTY
FLASHER W20-2	48" x 48"		2
FLASHER W20-3	48" x 48"		2
G20-X2	132" x 108" 132" x 12" 132" x 12"		1
G20-X2	132" x 108" 132" x 12" 132" x 12"		1
FLASHER R11-4 TYPE III	60" x 30" 8' FOOT		3
FLASHER M4-10L TYPE III	48" x 18" 8 FT.		1
FLASHER M4-10R TYPE III	48" x 18" 8 FT.		1

TO BE INSTALLED AT START OF CONSTRUCTION  
TO BE REMOVED AT START OF CONSTRUCTION

TO BE INSTALLED AT START OF CONSTRUCTION  
TO BE REMOVED AT START OF CONSTRUCTION

M.U.T.C.D. CODE	SIZE	INSERT	QTY
FLASHER M1-6	8 FT		2
R11-4 TYPE III	60" x 30" 8 FT		2
TYPE III	8 FT		6
M4-8 M3-4 M1-6	24" x 12" 24" x 12" 24" x 24" 21 x 15"		3 3 3 6
M4-8 M3-2 M1-6	24" x 12" 24" x 12" 24" x 14" 21 x 15"		3 2 3 2 6
M4-6 M4-8 M1-6	24" x 12" 24" x 12" 24" x 24"		2

STANDARD TRAFFIC CONTROL NOTES

- LOCATIONS OF ALL SIGNS ARE APPROXIMATE. EXACT LOCATIONS WILL BE DETERMINED IN THE FIELD BY THE ENGINEER.
- ALL BARRICADES SHALL BE PROPERLY WEIGHTED WITH SANDBAGS.
- ALL BARRICADES SHALL HAVE REFLECTIVE MATERIAL ON BOTH SIDES.
- ALL BARRICADE MARKINGS SHALL BE SLANTED IN ACCORDANCE WITH THE MINNESOTA MANUAL OF UNIFORM TRAFFIC CONTROL DEVICES.
- ALL TRAFFIC CONTROL DEVICES SHALL CONFORM TO THE MOST RECENT EDITION OF THE MINNESOTA MANUAL ON UNIFORM TRAFFIC CONTROL DEVICES, INCLUDING APPENDIX 'B', DATED NOV. 1992.
- ADDITIONS OR CHANGES TO THIS PLAN MAY BE MADE AS DETERMINED BY THE ENGINEER.

DETOUR QUANTITIES

REVISIONS			
DATE	BY	DATE	BY



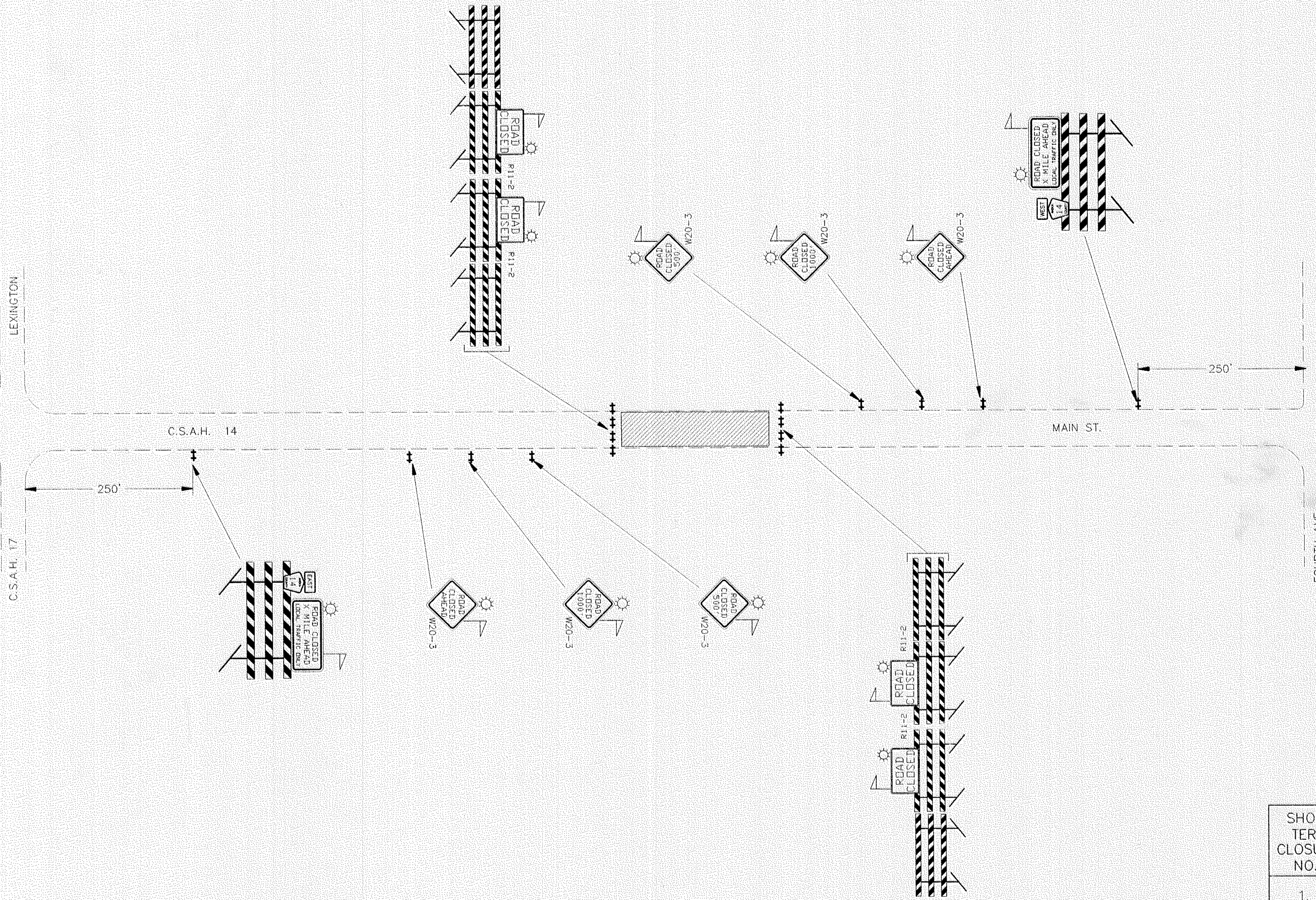

M.U.T.C.D. CODE	SIZE	INSERT	QTY
FLAG FLASHER W20-3	48" x 48"	500' 1000' AHEAD	• 2 • 2 • 2
TYPE III	8 FT.		• 4
FLAG FLASHER R11-2	48" x 30"	ROAD CLOSED	• 4
TYPE III	8 FT.		• 4
FLAG FLASHER M3-4	24" x 12"	SEE BELOW	1/4
M1-6	24" x 24"	ROAD CLOSED X MILE AHEAD LOCAL TRAFFIC ONLY	7/8
R11-3	60" x 30"	ROAD CLOSED X MILE AHEAD LOCAL TRAFFIC ONLY	1/2
TYPE III	8 FT.		3/4
FLAG FLASHER M3-4	24" x 12"	SEE BELOW	1/4
M1-6	24" x 24"	ROAD CLOSED X MILE AHEAD LOCAL TRAFFIC ONLY	1/2
R11-3	60" x 30"	ROAD CLOSED X MILE AHEAD LOCAL TRAFFIC ONLY	5/4
TYPE III	8 FT.		7/8

SHORT TERM CLOSURE NO.	LOCATION OF SHORT TERM CLOSURE	MILES FROM CSAH 17	MILES FROM FOURTH A.
1.	STA. 200+00 TO STA. 204+00	1/4	1 3/4
2.	STA. 215+00 TO STA. 217+50	1/2	1 1/2
3.	STA. 229+00 TO STA. 236+50	3/4	1
4.	STA. 239+00 TO STA. 242+50	7/8	7/8
5.	STA. 242+50 TO STA. 284+00	1	1/4

C.S.A.H. 14  
SHORT TERM ROAD CLOSURES

REVISIONS	DATE	BY