

PLAN SYMBOLS

- COUNTY LINE
- TOWNSHIP OR RANGE LINE
- SECTION LINE
- QUARTER LINE
- SIXTEENTH LINE
- RIGHT OF WAY LINE
- SLOPE EASEMENT
- EXISTING RIGHT OF WAY
- PROPERTY LINE
- CORPORATE OR CITY LIMITS
- RETAINING WALL
- RAILROAD
- RAILROAD RIGHT OF WAY
- RIVER OR CREEK
- DRAINAGE DITCH
- CULVERT
- DROP INLET
- GUARD RAIL
- BARBED WIRE FENCE
- WOVEN WIRE FENCE
- CHAIN LINK FENCE
- WOOD FENCE
- STONE WALL OR FENCE
- HEDGE

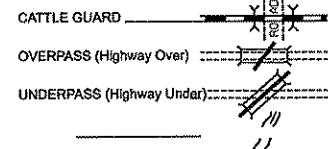
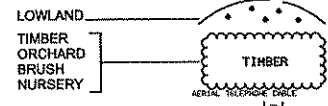

- BUILDING (One Story Frame) I-B-F
- F-FRAME C-CONCRETE
- S-STONE T-TILE
- B-BRICK ST-STUCCO
- RAILROAD CROSSING BELL
- RAILROAD CROSSING GATE
- MANHOLE
- CATCH BASIN
- FIRE HYDRANT
- CAST IRON MONUMENT
- IRON PIN
- GRAVEL PIT
- SAND PIT
- BORROW PIT
- ROCK QUARRY

UTILITY SYMBOLS

- POWER POLE LINE
- TELEPHONE OR TELEGRAPH POLE LINE
- JOINT TELEPHONE & POWER ON POWER POLES
- ON TELEPHONE POLES
- ANCHOR
- STEEL TOWER
- STREET LIGHT
- PEDESTAL (Cable Terminal)
- GAS MAIN
- WATERMAIN
- TELEPHONE CABLE IN CONDUIT
- ELECTRIC CABLE IN CONDUIT
- TELEPHONE MANHOLE
- ELECTRIC MANHOLE
- BURIED TELEPHONE CABLE
- BURIED ELECTRIC CABLE
- SEWER (Sanitary or Storm)
- SEWER MANHOLE

SCALES

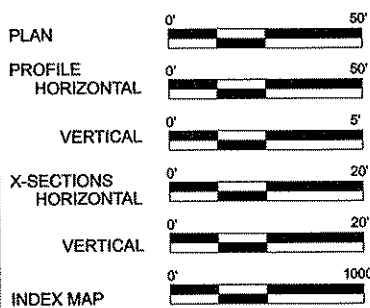

# MINNESOTA DEPARTMENT OF TRANSPORTATION

## ANOKA COUNTY

CONSTRUCTION PLAN FOR \_\_\_\_\_ GRADING, AGG.BASE, CONCRETE WALK SURFACING  
 LOCATED ON C.S.A.H. 14 BETWEEN WEDGEWOOD DRIVE AND ROUND LAKE BOULEVARD

STATE AID PROJECT NO. 02-614-37

C.S.A.H. 14

GROSS LENGTH	2059.16 FEET	0.390 MILES
BRIDGES-LENGTH	269.54 FEET	0.051 MILES
EXCEPTIONS-LENGTH	0.00 FEET	0.000 MILES
NET LENGTH	2059.16 FEET	0.390 MILES

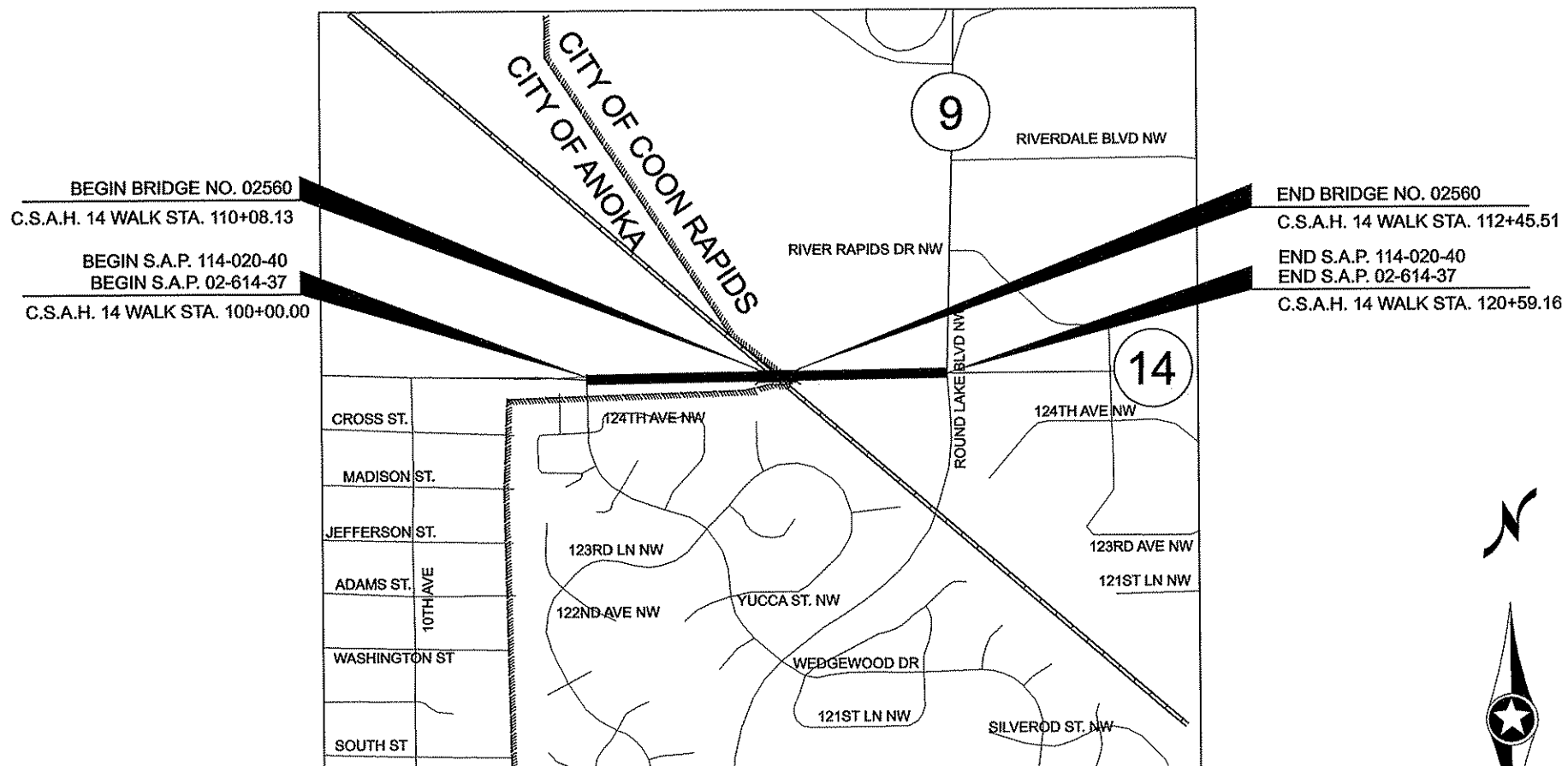

BEGIN BRIDGE NO. 02560

C.S.A.H. 14 WALK STA. 110+08.13

BEGIN S.A.P. 114-020-40

BEGIN S.A.P. 02-614-37

C.S.A.H. 14 WALK STA. 100+00.00

END BRIDGE NO. 02560

C.S.A.H. 14 WALK STA. 112+45.51

END S.A.P. 114-020-40

END S.A.P. 02-614-37

C.S.A.H. 14 WALK STA. 120+59.16

GOVERNING SPECIFICATIONS

THE 2005 EDITION OF THE MINNESOTA DEPARTMENT OF TRANSPORTATION "STANDARD SPECIFICATIONS FOR CONSTRUCTION" SHALL GOVERN. ALL TRAFFIC CONTROL DEVICES SHALL CONFORM AND BE INSTALLED IN ACCORDANCE TO THE "MINNESOTA MANUAL ON UNIFORM TRAFFIC CONTROL DEVICES" (MNMUTCD), AND PAR VI, "FIELD MANUAL FOR TEMPORARY TRAFFIC CONTROL ZONE LAYOUTS."

INDEX

SHEET NO.	DESCRIPTION
1	TITLE SHEET
2	STATEMENT OF ESTIMATED QUANTITIES
3	SOILS & CONSTRUCTION NOTES
4	UTILITY TABS, UTILITY & REMOVAL NOTES
5	TABULATIONS
6	EARTHWORK SUMMARY
7 - 11	TEMPORARY TRAFFIC CONTROL PLAN
12 - 13	INPLACE UTILITIES & REMOVAL PLAN
14	TYPICAL SECTIONS
15	EXISTING BRIDGE PLAN
16 - 19	MISCELLANEOUS DETAILS
20	ALIGNMENT PLAN AND TAB
21 - 24	CONSTRUCTION PLAN
25 - 29	SIGNING & STRIPING PLAN, TAB, & DETAILS
30 - 31	STORM WATER POLLUTION PREVENTION PLAN
32 - 36	EROSION CONTROL PLAN AND DETAILS
37 - 45	CROSS SECTIONS
1 - 6	BRIDGE PLANS

THIS PLAN CONTAINS 51 SHEETS

DESIGN DESIGNATION

**CSAH 14**

Functional Classification	A MINOR EXPANDER
No. of Traffic Lanes	<u>4</u> No. of Parking Lanes <u>0</u>
ADT (2010) =	17,686
Proj. ADT (2030) =	28,298
Proj. HCADT (2030) =	1,553
Soil Factor	NA

THE SUBSURFACE UTILITY INFORMATION IN THIS PLAN IS UTILITY QUALITY LEVEL D. THIS UTILITY QUALITY LEVEL WAS DETERMINED ACCORDING TO THE GUIDELINES OF C/ASCE 38-02, ENTITLED "STANDARD GUIDELINES FOR THE COLLECTION AND DEPICTION OF EXISTING SUBSURFACE UTILITY DATA".

Approved 12/10/2010 ANOKA COUNTY ENGINEER

Approved 12/14/2010 CITY OF COON RAPIDS

RECOMMENDED FOR APPROVAL Duane R. Hill 12/29/2010  
STATE BRIDGE ENGINEER

REVIEWED FOR COMPLIANCE WITH STATE AND FEDERAL AID RULES/POLICY D. E. Embree 12/22/2010  
DISTRICT STATE AID ENGINEER

Approved for State Funding D. E. Embree 12/22/2010  
STATE AID ENGINEER

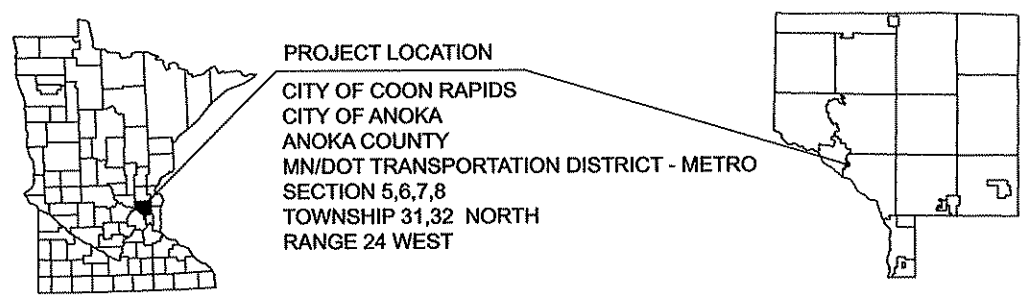

PROJECT LOCATION  
 CITY OF COON RAPIDS  
 CITY OF ANOKA  
 ANOKA COUNTY  
 MN/DOT TRANSPORTATION DISTRICT - METRO  
 SECTION 5,6,7,8  
 TOWNSHIP 31,32 NORTH  
 RANGE 24 WEST

I HEREBY CERTIFY THAT THIS PLAN WAS PREPARED BY ME OR UNDER MY DIRECT SUPERVISION AND THAT I AM A DULY LICENSED PROFESSIONAL ENGINEER UNDER THE LAWS OF THE STATE OF MINNESOTA.

PRINT NAME: CURT A. KOBILARCSIK  
 SIGNATURE:   
 DATE: 12-9-10 LICENSE NO. 24766

DRAWN BY NJD DATE 8-18-10  
 DESIGN BY NJD DATE 5-26-10  
 CHECKED BY JEO DATE 11-29-10



ANOKA COUNTY  
 HIGHWAY DEPT.

STATE AID PROJECT NO. 02-614-37  
 COON RAPIDS CITY NO. 06-48  
 MN STATE PROJECT NO. 114-020-40

TITLE SHEET

Sheet 1 of 51 Sheets

NO	DATE	BY	CKD	APPR	REVISION

TAB / NOTE	ITEM NO.	ITEM DESCRIPTION	UNIT	TOTAL PROJECT QUANTITIES ESTIMATED	SAP 02-614-37	SAP 114-020-40
					ANOKA COUNTY	CITY OF COON RAPIDS
					ROADWAY QUANTITIES ESTIMATED	ROADWAY QUANTITIES ESTIMATED
	2021.501	MOBILIZATION	LUMP SUM	1	0.12	0.88
J	2102.502	PERMANENT PAVEMENT MARKING REMOVAL	LIN FT	778		778
B	2104.501	REMOVE CURB AND GUTTER	LIN FT	484		484
B	2104.501	REMOVE GUARD RAIL	LIN FT	225	225	
B	2104.503	REMOVE BITUMINOUS PAVEMENT	SQ FT	1041		1041
B	2104.505	REMOVE CONCRETE SLAB	SQ YD	23		23
B	2104.513	SAWING BITUMINOUS PAVEMENT (FULL DEPTH)	LIN FT	385		385
C	2104.523	SALVAGE SIGN TYPE C	EACH	14	14	
1	2104.601	HAUL SALVAGED MATERIAL	LUMP SUM	1	1	
A	2105.501	COMMON EXCAVATION (EV)(P)	CU YD	995		995
A	2105.523	COMMON BORROW (LV)	CU YD	639		639
G	2360.501	TYPE SP 12.5 WEARING COURSE MIXTURE (3,F)	TON	25		25
E	2411.507	CONCRETE FLUME	EACH	2		2
H	2511.501	RANDOM RIPRAP CLASS II	CU YD	16		16
H	2511.515	GEOTEXTILE FILTER TYPE III	SQ YD	37		37
E	2521.501	4" CONCRETE WALK	SQ FT	8668		8668
E	2521.501	4" CONCRETE WALK SPECIAL	SQ FT	345		345
E	2531.501	CONCRETE CURB AND GUTTER DESIGN B412	LIN FT	387		387
F	2531.618	TRUNCATED DOMES	SQ FT	32		32
E	2531.618	PEDESTRIAN CURB RAMP	SQ FT	249		249
K, 2	2533.507	PORTABLE PRECAST CONCRETE BARRIER DESIGN 8337	LIN FT	575		575
	2545.602	ADJUST HANDHOLE	EACH	2		2
3	2550.602	RELOCATE SIGN	EACH	1		1
K	2554.501	TRAFFIC BARRIER DESIGN SPECIAL	LIN FT	50	50	
K	2554.501	TRAFFIC BARRIER DESIGN B8338	LIN FT	130	130	
K	2554.602	IMPACT ATTENUATOR BARRELS	EACH	22		22
K	2554.615	IMPACT ATTENUATOR	ASSEMBLY	2	2	
D	2557.501	WIRE FENCE DESIGN 60V-9322	LIN FT	1599		1599
	2563.601	TRAFFIC CONTROL	LUMP SUM	1		1
I	2564.531	SIGN PANELS TYPE C	SQ FT	64.9	64.9	
H	2573.502	SILT FENCE TYPE MACHINE SLICED	LIN FT	1826		1826
H	2573.530	STORM DRAIN INLET PROTECTION	EACH	6		6
H	2575.501	SEEDING	ACRE	1.06		1.06
H	2575.502	SEED MIXTURE 240	POUND	80		80
H	2575.505	SODDING TYPE SALT RESISTANT	SQ YD	1219		1219
H	2575.523	EROSION CONTROL BLANKETS CATEGORY 3	SQ YD	5149		5149
H	2575.532	FERTILIZER TYPE 3	POUND	524		524
H	2575.571	RAPID STABILIZATION METHOD 3	MGAL	6.6		6.6
J	2582.502	4" SOLID LINE WHITE - EPOXY	LIN FT	5477	5477	
J	2582.502	4" BROKEN LINE WHITE-EPOXY	LIN FT	840	840	
J	2582.502	4" SOLID LINE YELLOW-EPOXY	LIN FT	4143	4143	

THE FOLLOWING STANDARD PLATES APPROVED BY THE DEPARTMENT OF TRANSPORTATION FEDERAL HIGHWAY ADMINISTRATION SHALL APPLY ON THIS PROJECT.

STANDARD PLATES	
PLATE NO.	DESCRIPTION
7020J	CONCRETE CURB AND GUTTER (2 SHEETS)
7036F	PEDESTRIAN CURB RAMP (2 SHEETS)
8000I	STANDARD BARRICADES
8337B	TEMPORARY PORTABLE PRECAST CONCRETE BARRIER (TYPE F) (2 SHEETS)
8338C	W-BEAM GUARDRAIL & END ANCHORAGES (2 SHEETS)
9322K	CHAIN LINK FENCE (2 SHEETS)

BASIS OF QUANTITIES		
SPEC NO	DESCRIPTION	RATE
2360.521	TYPE SP 12.5 MIXTURE (3,F)	115 LBS / SQ YD / IN
2575.502	SEED MIXTURE 240	75 LBS / ACRE
2575.571	RAPID STABILIZATION METHOD 3	6 M GALLONS / ACRE
2575.531	FERTILIZER TYPE 3	400 LBS / ACRE

INDEX OF TABULATION CHARTS		
TAB.	DESCRIPTION	SHEET NO.
A	EARTHWORK SUMMARY	6
B	REMOVALS & SAWING	5
C	SALVAGE SIGNS	26
D	CHAIN LINK FENCE	5
E	CONCRETE SUMMARY	5
F	TRUNCATED DOMES	5
G	BITUMINOUS SUMMARY	5
H	TURF ESTABLISHMENT AND EROSION CONTROL	5
I	SIGN PANELS TYPE C	26
J	STRIPING SUMMARY	26
K	TRAFFIC BARRIER	5
AA	PRIVATE UTILITY OWNERS	4
BB	ANOKA COUNTY- INTERCONNECT	4
CC	ANOKA - POWER LINE	4
DD	CONNEXUS ENERGY	4
EE	QWEST	4

12-28-10	NJD	NJD	CAK	UPDATED ESTIMATED QUANTITY COLUMNS
NO	DATE	BY	CHKD	APPR
NAME: P:\14_PED\Plan14_PED_SEQ1.dgn	REVISION	12/28/2010	11:36:30 AM	

I HEREBY CERTIFY THAT THIS PLAN WAS PREPARED BY ME OR UNDER MY DIRECT SUPERVISION AND THAT I AM A DULY LICENSED PROFESSIONAL ENGINEER UNDER THE LAWS OF THE STATE OF MINNESOTA.  
 PRINT NAME: CURT A. KOBILARCSIK  
 SIGNATURE: *Curt Kobilarsik*  
 DATE: 12-28-10 LICENSE NO. 24756

DRAWN BY: NJD DATE: 8-19-10  
 DESIGN BY: NJD DATE: 5-26-10  
 CHECKED BY: JED DATE: 11-29-10

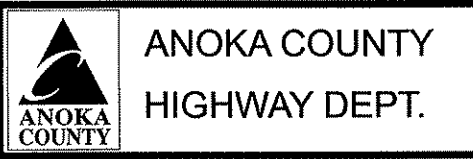

STATE AID PROJECT NO. 02-614-37  
 COON RAPIDS CITY NO. 06-48  
 MN STATE PROJECT NO. 114-020-40

STATEMENT OF ESTIMATED QUANTITIES  
 Sheet 2 of 51 Sheets

**SOILS & CONSTRUCTION NOTES**

1. SUITABLE GRADING MATERIAL CONSISTS OF MINERAL SOILS WHICH ARE FREE OF ORGANIC CONTENT AND DEBRIS, ARE NON-EXPANSIVE, AND ARE IN A CONDITION WHICH CAN MEET SPECIFIED COMPACTION LEVELS.
2. SLOPE DRESSING ON THE PROJECT IS DEFINED AS THE TOPSOIL OR OTHER SOIL PLACED DURING PRIOR CONSTRUCTION TO PROVIDE A MEDIUM FOR ESTABLISHING TURF. THESE SOILS MAY NOT MEET THE MINIMUM ORGANIC CONTENT AND OTHER REQUIREMENTS FOR TOPSOIL BORROW
3. ALL TOPSOIL STRIPPING WILL BE CONSIDERED TO BE COMMON EXCAVATION.
4. TOPSOIL SHALL BE DEFINED AS EXISTING SOILS WHICH MEET MN/DOT THE STUFF 3877 THAT WOULD BE SUITABLE FOR REUSE.
5. SLOPE DRESSING ON THE PROJECT IS DEFINED AS THE TOPSOIL OR OTHER SOIL PLACED DURING PRIOR CONSTRUCTION TO PROVIDE A MEDIUM FOR ESTABLISHING TURF.
6. UNSUITABLE SOILS ARE DEFINED AS SOILS WHICH DO NOT MEET OR ARE NOT MANUFACTURED TO MEET ANY OF THE ABOVE DEFINED CATEGORIES, AND ARE THEREFORE NOT REUSABLE AS STRUCTURAL BACKFILL OR EMBANKMENT WITHIN THE ROADWAY CORE.
7. AGGREGATE BASE MATERIAL SHALL BE CRUSHED AND MEET THE REQUIREMENTS OF MN/DOT SPEC. 3138, CLASS 5.
8. EMBANKMENT CONSTRUCTION SHALL BE PERFORMED AS REQUIRED BY MN/DOT SPECIFICATION 2105
9. ANY DEBRIS WHICH MAY BE ENCOUNTERED DURING GRADING SHALL BECOME PROPERTY OF THE CONTRACTOR AND DISPOSED OF OFF THE PROJECT RIGHT OF WAY IN A SUITABLE DISPOSAL AREA AS APPROVED BY THE ENGINEER.
10. UNSUITABLE SOILS NOT USED ON THE PROJECT SHALL BECOME THE PROPERTY OF THE CONTRACTOR AND REMOVED FROM THE PROJECT AND DISPOSED OF IN ACCORDANCE WITH MN/DOT SPECIFICATIONS.
11. UNLESS OTHERWISE SPECIFICALLY ALLOWED OR REQUIRED BY THE CONTRACT, BITUMINOUS AND CONCRETE ITEMS DISTURBED BY CONSTRUCTION SHALL BECOME THE PROPERTY OF THE CONTRACTOR AND SHALL BE RECYCLED TO THE EXTENT ALLOWED IN BASE AND SURFACING ITEMS OR DISPOSED OF OUTSIDE THE RIGHT-OF-WAY IN ACCORDANCE WITH SPEC. 2104.3C3.
12. STRIP ALL TOPSOIL AND INPLACE SLOPE DRESSING WHERE PRESENT IN AREAS TO BE DISTURBED BY CONSTRUCTION AND REUSE AS SLOPE DRESSING. FOR ESTIMATING PURPOSES, THE DEPTH OF TOPSOIL AVAILABLE IS CONSIDERED TO BE 4 INCHES. CONTRACTOR TO VERIFY PRIOR TO PLACING BID
13. PROVIDE A SAWCUT WHERE PLACING NEW PAVEMENT ADJACENT TO INPLACE PAVEMENT TO ENSURE A UNIFORM JOINT.
14. THE CONSTRUCTION LIMITS AS SHOWN IN THE PLANS REPRESENT THE POINT OF INTERSECTION BETWEEN THE REQUIRED FILL OR CUT SLOPE AND THE EXISTING GROUND LINE AS DEPICTED ON THE CROSS SECTIONS. THE CONSTRUCTION LIMITS DO NOT INCLUDE AREAS REQUIRED FOR SLOPE ROUNDING.
15. USE TACK COAT BETWEEN ALL BITUMINOUS MIXTURES AND PRIOR TO PLACING ANY BITUMINOUS MIXTURES ON THE EXISTING PAVEMENT. THE BITUMINOUS TACK COAT MATERIAL SHALL BE APPLIED AT A UNIFORM RATE OF 0.03 TO 0.05 GALLONS/SQ. YD. BETWEEN BITUMINOUS LAYERS AND 0.07 TO 0.10 GALLONS/SQ. YD. ON CONCRETE OR MILLED BITUMINOUS SURFACES PRIOR TO BEING OVERLAID. THE APPLICATION RATES ARE FOR UNDILUTED EMULSIONS (AS SUPPLIED FROM THE REFINERY) OR MC AND RC LIQUID ASPHALTS. THE ASPHALT EMULSION MAY BE FURTHER DILUTED IN THE FIELD IN ACCORDANCE WITH SPECIFICATION 2357.
16. ALL BITUMINOUS MIXTURES SHALL CONFORM TO MNDOT SPEC 2360
17. DITCH BOTTOMS, TOE OF FILL, CUT RUNOUTS AND THE TOP EDGE OF THE BACKSLOPES SHALL BE ROUNDED REGARDLESS OF THE SECTION USED ON THE CROSS SECTION SHEETS.
18. COMPACTION OF ALL AGGREGATE BASE, GRANULAR, AND SELECT GRANULAR MATERIAL SHOULD BE IN ACCORDANCE WITH MN/DOT "QUALITY COMPACTION METHOD"
19. COMPACTION OF ALL PERMANENT BITUMINOUS MIXTURES SHALL BE THE "MAXIMUM DENSITY METHOD"

NO	DATE	BY	CHKD	APPR	REVISION

NAME: p:\14\_ped\plan14\_PED\_SCN.dgn      12/01/2010      2:13:57 PM

I HEREBY CERTIFY THAT THIS PLAN WAS PREPARED BY ME OR UNDER MY DIRECT SUPERVISION AND THAT I AM A DULY LICENSED PROFESSIONAL ENGINEER UNDER THE LAWS OF THE STATE OF MINNESOTA.

PRINT NAME: CURT A. KOBILARCSIK  
 SIGNATURE: *Curt Kobilarsik*  
 DATE: 12-9-10      LICENSE NO. 24756

DRAWN BY: NJD      DATE: 8-19-10  
 DESIGN BY: NJD      DATE: 5-26-10  
 CHECKED BY: JEO      DATE: 11-29-10



STATE AID PROJECT NO. 02-614-37  
 COON RAPIDS CITY NO. 06-48  
 MN STATE PROJECT NO. 114-020-40

PRIVATE UTILITY OWNERS		AA
ACCESS COMMUNICATION TECH TEL. (763)-545-9998	CENTER POINT ENERGY TEL. (866)-861-7678	
ANOKA COUNTY TEL. (763)-862-4234	QWEST TEL. (866)-861-7678	
CITY OF ANOKA TEL. (763)-576-2902	XCEL ENERGY TEL. (800)-762-0592	
CITY OF COON RAPIDS TEL. (763)-767-6462	COMCAST TEL. (952)-607-4084	
CONNEXUS ENERGY (763)-323-4216		

**GENERAL UTILITY NOTES**

- IT SHALL BE THE CONTRACTOR'S RESPONSIBILITY TO UTILIZE THE GOPHER STATE ONE CALL EXCAVATION NOTICE SYSTEM REQUIRED BY MINNESOTA STATUTE, CHAPTER 216D FOR ALL UNDERGROUND UTILITY LOCATIONS.
- THE SUBSURFACE UTILITY INFORMATION IN THIS PLAN IS UTILITY QUALITY LEVEL D. THIS UTILITY QUALITY LEVEL WAS DETERMINED ACCORDING TO THE GUIDELINES OF C/ASCE 38-02, ENTITLED "STANDARD GUIDELINES FOR THE COLLECTION AND DEPICTION OF EXISTING SUBSURFACE UTILITY DATA".
- CONTRACTOR SHALL PROTECT ALL EXISTING UTILITIES
- ALL PRIVATE IRRIGATION SYSTEMS DISTURBED BY CONSTRUCTION LIMITS SHALL BE REPLACED AND REINSTALLED AS DIRECTED BY THE CITY (THE CONTRACTOR SHALL TAKE CARE TO PROTECT OR SALVAGE IRRIGATION SYSTEM COMPONENTS WITHIN THE CONSTRUCTION LIMITS)

**GENERAL REMOVAL NOTES**

- SEE SIGNING & STRIPING PLAN SHEETS 25 - 26 FOR SIGN REMOVAL AND REPLACEMENT
- THE CONTRACTOR SHALL PROTECT ANY TREES, FENCING, OR OTHER LANDSCAPING WITHIN THE RIGHT-OF-WAY UNLESS OTHERWISE NOTED IN THE PLANS.
- CONTRACTOR TO VERIFY REMOVAL LIMITS WITH ENGINEER PRIOR TO SAWCUTTING.
- PROTECT ALL EXISTING STORM SEWER MANHOLES AND CATCHBASINS.

ANOKA COUNTY- INTERCONNECT				BB
STATION		OFFSET	SIZE & ITEM	REMARKS
BEGIN	END			
100+00		LT	INTERCONNECT	LEAVE AS IS
100+00		RT	INTERCONNECT	LEAVE AS IS
100+00	100+19	RT - LT	INTERCONNECT	LEAVE AS IS
100+19	102+07	LT	INTERCONNECT	LEAVE AS IS
102+07	104+00	LT	INTERCONNECT	LEAVE AS IS
104+00	106+00	LT	INTERCONNECT	LEAVE AS IS
106+00	108+00	LT	INTERCONNECT	LEAVE AS IS
108+00	110+00	LT - RT	INTERCONNECT	LEAVE AS IS
110+00	112+72	RT	INTERCONNECT	LEAVE AS IS
112+72	114+40	RT - LT	INTERCONNECT	LEAVE AS IS
114+40	116+12	LT	INTERCONNECT	LEAVE AS IS
116+12	117+37	LT	INTERCONNECT	LEAVE AS IS
117+37	119+16	LT	INTERCONNECT	LEAVE AS IS
119+16	120+59	LT - RT	INTERCONNECT	LEAVE AS IS

ANOKA - POWER LINE				CC
STATION		OFFSET	SIZE & ITEM	REMARKS
BEGIN	END			
101+51	103+14	LT	POWER LINE	LEAVE AS IS
103+14	104+79	LT	POWER LINE	LEAVE AS IS
104+79	106+49	LT	POWER LINE	LEAVE AS IS
106+49	108+15	LT	POWER LINE	LEAVE AS IS
108+15	109+80	LT - RT	POWER LINE	LEAVE AS IS
109+80	112+99	RT - LT	POWER LINE	LEAVE AS IS
112+99	114+58	LT	POWER LINE	LEAVE AS IS
114+58	116+22	LT	POWER LINE	LEAVE AS IS
116+22	117+85	LT	POWER LINE	LEAVE AS IS
117+85	119+50	LT	POWER LINE	LEAVE AS IS

CONNEXUS ENERGY				DD
STATION		OFFSET	SIZE & ITEM	REMARKS
BEGIN	END			
118+53		OH	OHP	LEAVE AS IS
118+55		OH	OHP	LEAVE AS IS
118+64		OH	OHP	LEAVE AS IS
118+65		OH	OHP	LEAVE AS IS
119+54		LT - RT	P-BUR	LEAVE AS IS
120+60		LT - RT	P-BUR	LEAVE AS IS
120+85		LT - RT	P-BUR	LEAVE AS IS

QWEST- TELEPHONE				EE
STATION		OFFSET	SIZE & ITEM	REMARKS
BEGIN	END			
100+07.50	120+59.16	RT	CABLE	LEAVE AS IS
120+52.09		RT	VAULT	LEAVE AS IS
120+59.16		RT	VAULT	LEAVE AS IS

NO	DATE	BY	CKD	APPR	REVISION

NAME: p114\_pediplan14\_PED\_SEQ1.dgn 12/01/2010 2:13:54 PM

I HEREBY CERTIFY THAT THIS PLAN WAS PREPARED BY ME OR UNDER MY DIRECT SUPERVISION AND THAT I AM A DULY LICENSED PROFESSIONAL ENGINEER UNDER THE LAWS OF THE STATE OF MINNESOTA.  
 PRINT NAME: CURT A. KOBILARCSIK  
 SIGNATURE: *Curt Kobilarcsik*  
 DATE: 12-9-10 LICENSE NO. 24756

DRAWN BY: NJD DATE: 8-19-10  
 DESIGN BY: NJD DATE: 5-28-10  
 CHECKED BY: JEO DATE: 11-29-10



ANOKA COUNTY  
HIGHWAY DEPT.

STATE AID PROJECT NO. 02-614-37  
 COON RAPIDS CITY NO. 06-48  
 MN STATE PROJECT NO. 114-020-40

UTILITY TABULATIONS  
 Sheet 4 of 51 Sheets



REMOVALS & SAWING							B
STATION TO STATION	OFFSET	REMOVE (SPEC. 2104)	SAWING (SPEC. 2104)	REMOVE (SPEC. 2104)	REMOVE (SPEC. 2104)	REMOVE (SPEC. 2104)	NOTES
		BITUMINOUS PAVEMENT [3] (SQ FT)	BITUMINOUS PAVEMENT (LIN FT)	CONC. CURB & GUTTER (LIN FT)	GUARD RAIL [2] (LIN FT)	CONCRETE SLAB [1] (SQ YD)	
110+00.00				25		17	
108+50.43 - 110+08.46				159	115		
108+50.59 - 109+72.24		301	122				
112+56.97 - 115+36.39				280	110		
112+73.19 - 115+36.39		740	263				
120+59.16				20		6	
PROJECT TOTAL		1041	385	484	225	23	

**REMOVAL NOTES:**  
 [1] ITEM FOR REMOVAL OF EXISTING PEDESTRIAN CURB RAMPS  
 [2] QUANTITY INCLUDES REMOVAL OF ANCHORAGE ASSEMBLIES AND RADIUS NOSE SECTIONS  
 [3] ASSUMED PAVEMENT DEPTH OF 6" FOR INFORMATION ONLY. CONTRACTOR TO VERIFY PRIOR TO PLACING BID.

TRUNCATED DOMES			F
STATION	OFFSET EB	DESCRIPTION	SQ FT
100+00	RIGHT	PEDESTRIAN RAMP	16
120+59.16	RIGHT	PEDESTRIAN RAMP	16
TOTAL			32

CHAIN LINK FENCE			D
STATION	OFFSET	WIRE FENCE DESIGN 60V-9322 (SPEC 2557) (LIN FT)	NOTES
101+47.00 - 110+08.00	LT	860	
112+57.00 - 119-96.00	LT	739	
PROJECT TOTAL		1599	

TURF ESTABLISHMENT AND EROSION CONTROL											H	
LOCATION	SILT FENCE	STORM DRAIN INLET PROTECTION	SOD TYPE SALT RESISTANT	PERMANENT EROSION CONTROL								TEMPORARY EROSION CONTROL
				SEEDING	SEED MIXTURE 240	EROSION CONTROL BLANKET CAT. 3	RANDOM RIPRAP CLASS II	GEOTEXTILE FABRIC TYPE III [1]	FERTILIZER TYPE 3	RAPID STABILIZATION METHOD 3		
				ACRE	POUND	SQ YD	CU YD	SQ YD	POUND	M GAL		
100+00.00 - 110+10.07	1006	1		0.58	44	2795	11	22	232	3.6		
100+00.00 - 110+10.07		2	626						52			
112+95.11 - 120+59.16	820	1		0.48	36	2354	5	15	192	3.0		
112+95.11 - 120+59.16		2	593						48			
PROJECT TOTAL		1826	6	1219	1.06	80	5149	16	37	524	6.6	

**TURF ESTABLISHMENT NOTES:**  
 [1] THE GEOTEXTILE FABRIC SHOULD COVER THE AREA OF THE RIPRAP AND EXTEND 1.0' UNDER THE WEST FLUME AND 3.0' UNDER THE EAST FLUME.

BITUMINOUS SUMMARY				G
STATION	TO	STATION	2360 TYPE SP 12.5 WEAR (SPWEB340F) [3] TON	NOTES
108+50.43	-	109+73.84	8	[1], [2]
112+73.19	-	115+36.36	17	[1], [2]
TOTAL			25	

**BITUMINOUS SUMMARY NOTES:**  
 [1] TO BE USED AS A PACTHING MATERIAL BETWEEN LIP OF PROPOSED CURB AND SAWCUT  
 [2] BITUMINOUS TACK COAT INCIDENTAL (IF NECESSARY)  
 [3] QUANTITY BASED ON PROPOSED ASSUMED DEPTH OF 6 INCHES

TRAFFIC BARRIER							K
LOCATION	TRAFFIC BARRIER [1]					SNOW PLOW MARKER X4-5 [3]	NOTES
	DESIGN SPECIAL [1]	DESIGN B8338 [4]	IMPACT ATTENUATOR [2]	IMPACT ATTENUATOR BARRELS	PORTABLE CONCRETE BARRIER DESIGN 8337		
STATION TO STATION	LIN FT	LIN FT	EACH	EACH	LIN FT	EACH	
108+35.53 - 109+75.53	25	85	1	11	288	1	
112+75.12 - 113+76.54	25	45	1	11	287	1	
PROJECT TOTAL		50	130	2	22	575	2

**TRAFFIC BARRIER NOTES:**  
 [1] QUANTITY INCLUDED FOR TRANSITION TO BRIDGE RAILING  
 [2] IMPACT ATTENUATOR SHALL BE THE CRASH-CUSHION/ATTENUATING TERMINAL, (CAT) SYSTEM MANUFACTURED BY TRINITY INDUSTRIES, INC., DALLAS TX  
 [3] SNOW PLOW MARKERS INCIDENTAL TO ITEM 2554.615 IMPACT ATTENUATOR.  
 [4] QUANTITY DOES NOT INCLUDE LENGTH REQUIRED FOR IMPACT ATTENUATOR

NO	DATE	BY	CHKD	APPR	REVISION

NAME: PA14\_PEDIPlan14\_PED\_SEQ1.dgn  
 12/09/2010 11:13:30 AM

I HEREBY CERTIFY THAT THIS PLAN WAS PREPARED BY ME OR UNDER MY DIRECT SUPERVISION AND THAT I AM A DULY LICENSED PROFESSIONAL ENGINEER UNDER THE LAWS OF THE STATE OF MINNESOTA.  
 PRINT NAME: CURT A. KOBILARCSIK  
 SIGNATURE: *Curt Kobilarcsik*  
 DATE: 12-9-10 LICENSE NO. 24758

DRAWN BY: NJD DATE: 8-19-10  
 DESIGN BY: NJD DATE: 5-28-10  
 CHECKED BY: JEO DATE: 11-28-10

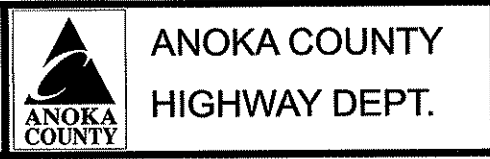

STATE AID PROJECT NO. 02-614-37  
 COON RAPIDS CITY NO. 06-48  
 MN STATE PROJECT NO. 114-020-40

STATION	EXCAVATION		EMBANKMENT	
	COMMON (C.Y.)	SLOPE DRESSING (C.Y.)	SUITABLE GRADING (C.Y.)	
100+00.00				
100+19.13	6	3	0	
100+50.00	13	7	0	
101+00.00	20	10	0	
101+51.27	20	11	3	
102+06.99	20	12	7	
102+50.00	16	11	6	
103+00.00	24	15	8	
103+14.52	8	5	2	
103+50.00	20	13	3	
103+96.50	27	20	5	
104+50.00	34	26	12	
104+79.11	20	16	14	
105+00.00	16	12	21	
105+50.00	37	31	60	
105+95.64	39	30	24	
106+49.28	66	37	3	
107+00.00	62	35	2	
107+50.00	39	28	5	
107+94.79	28	19	4	
108+14.50	12	6	1	
108+50.00	17	9	1	
109+00.00	17	8	2	
109+50.00	22	7	2	
109+75.97	17	3	0	
109+80.08	1	0	0	
109+95.37	2	1	0	
110+08.13	1	1	1	
112+71.90	32	20	13	
112+78.74	0	0	0	
112+98.51	2	1	1	
113+50.00	9	5	5	
114+00.00	29	27	16	
114+41.53	39	39	73	
114+57.84	15	15	48	
115+00.00	40	38	114	
115+50.00	46	44	113	
116+11.59	46	43	78	
116+22.04	5	4	5	
117+00.00	29	21	29	
117+36.48	12	9	10	
117+50.00	5	3	3	
117+84.46	11	7	6	
118+00.00	5	3	2	
118+53.69	23	10	2	
118+64.96	5	2	0	
119+00.00	11	7	1	
119+16.25	4	3	1	
119+50.00	9	6	4	
120+00.00	14	9	5	

EARTHWORK SUMMARY			A
STATION	EXCAVATION TOTALS	EMBANKMENT VOLUMES	
	COMMON (C.Y.)	SLOPE DRESSING (C.Y.)	SUITABLE GRADING (C.Y.)
PROJECT TOTAL	995	692	715

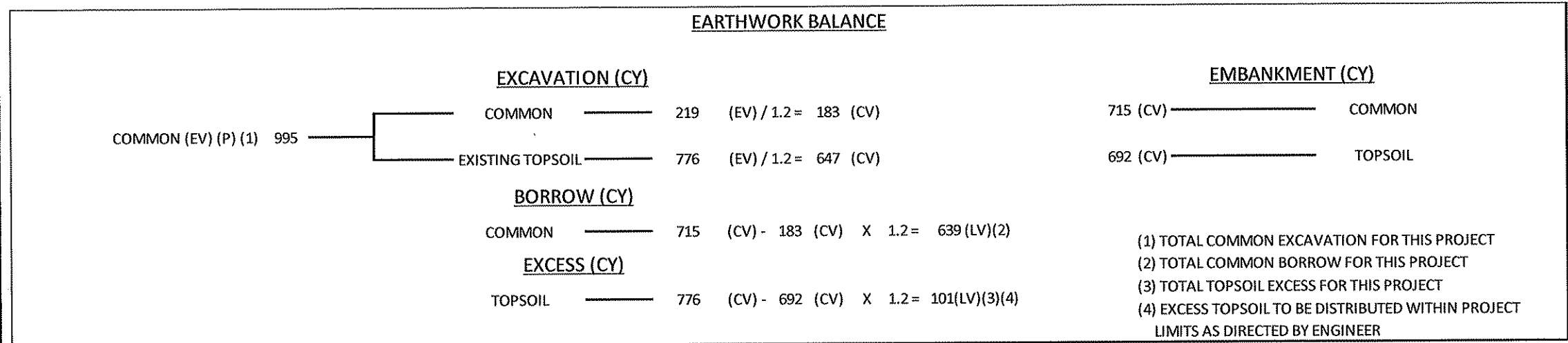

**NOTES:**

ASSUMED 120% SHRINKAGE FACTOR USED FROM EXCAVATED VOLUME (EV) TO COMPACTED VOLUME (CV). SHRINKAGE FACTORS ARE ASSUMED VALUES, USED ONLY FOR THE PURPOSE OF ESTIMATED QUANTITIES. IT SHALL BE UNDERSTOOD THAT NO WARRANTY IS MADE OR IMPLIED AS TO THE ACCURACY, SUFFICIENCY, OR RELIABILITY OF SHRINKAGE FACTORS.

SEE SOILS AND CONSTRUCTION NOTES FOR MATERIAL DEFINITIONS AND ADDITIONAL INFORMATION

ALL MATERIAL NOT USED ON THE PROJECT SHALL BECOME THE PROPERTY OF THE CONTRACTOR AND SHALL BE REMOVED FROM THE PROJECT LIMITS WITH NO DIRECT PAYMENT THEREFORE. THE MATERIAL QUANTITY IS BASED ON ESTIMATED QUANTITIES. DISPOSAL SHALL BE IN ACCORDANCE WITH SPEC. 2105

THE CONTRACTOR SHALL OBTAIN APPROVAL FROM THE ENGINEER BEFORE HAULING MATERIAL OFF SITE.

NO	DATE	BY	CKD	APPR	REVISION

NAME: p:\14\_ped\plant14\_PED\_EW1.dgn 12/01/2010 2:14:00 PM

I HEREBY CERTIFY THAT THIS PLAN WAS PREPARED BY ME OR UNDER MY DIRECT SUPERVISION AND THAT I AM A DULY LICENSED PROFESSIONAL ENGINEER UNDER THE LAWS OF THE STATE OF MINNESOTA.  
 PRINT NAME: CURT A. KOBILARCSIK  
 SIGNATURE: *Curt Kobilarsik*  
 DATE: 12-9-10 LICENSE NO. 24766

DRAWN BY: NJD DATE: 11-01-10  
 DESIGN BY: NJD DATE: 11-01-10  
 CHECKED BY: JEO DATE: 11-29-10



STATE AID PROJECT NO. 02-614-37  
 COON RAPIDS CITY NO. 06-48  
 MN STATE PROJECT NO. 114-020-40

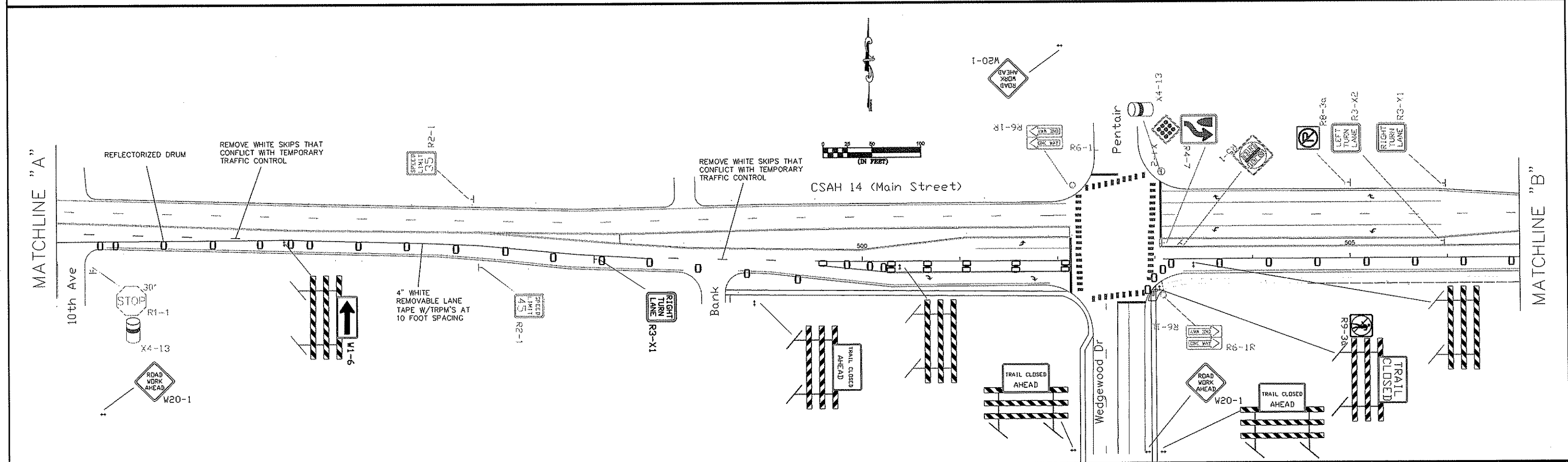
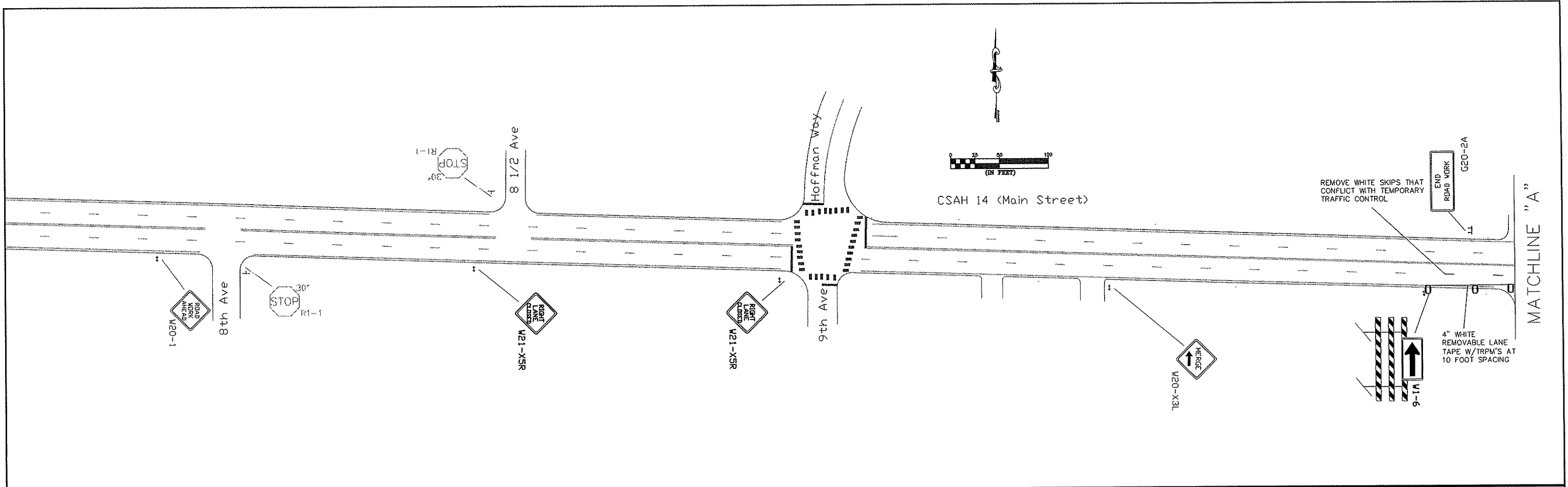

					I HEREBY CERTIFY THAT THIS PLAN WAS PREPARED BY ME OR UNDER MY DIRECT SUPERVISION AND THAT I AM A DULY LICENSED PROFESSIONAL ENGINEER UNDER THE LAWS OF THE STATE OF MINNESOTA.		DRAWN BY: MTH DATE 05/27/10			STATE AID PROJECT NO. 02-614-37		TRAFFIC CONTROL	
					PRINT NAME: CURT A. KOBILARCSIK		DESIGN BY: MTH DATE 05/27/10			COON RAPIDS PROJECT NO. 06-48			
					SIGNATURE: <i>Curt Kobilarsik</i>		CHECKED BY: RB DATE 6/01/10		MN STATE PROJECT NO. 114-20-40		Sheet 07 of 51 Sheets		
NAME: P:\14_PED\Bases\TRAFFIC\14_Ped_Traffic Control.dwg					DATE: 12-9-10 LICENSE NO. 24756								

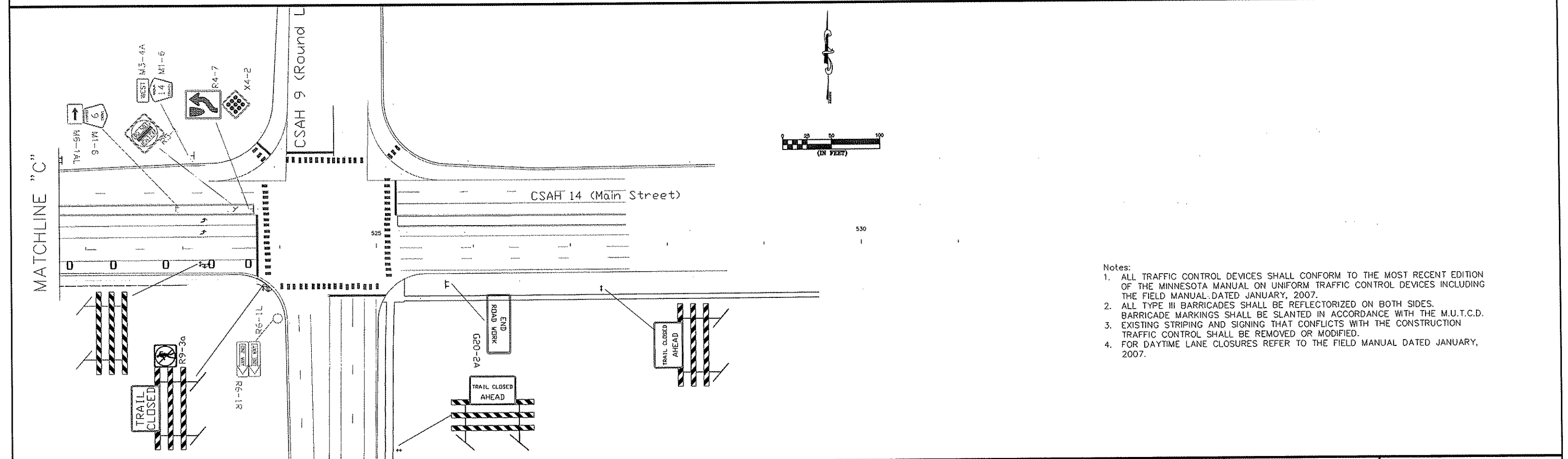
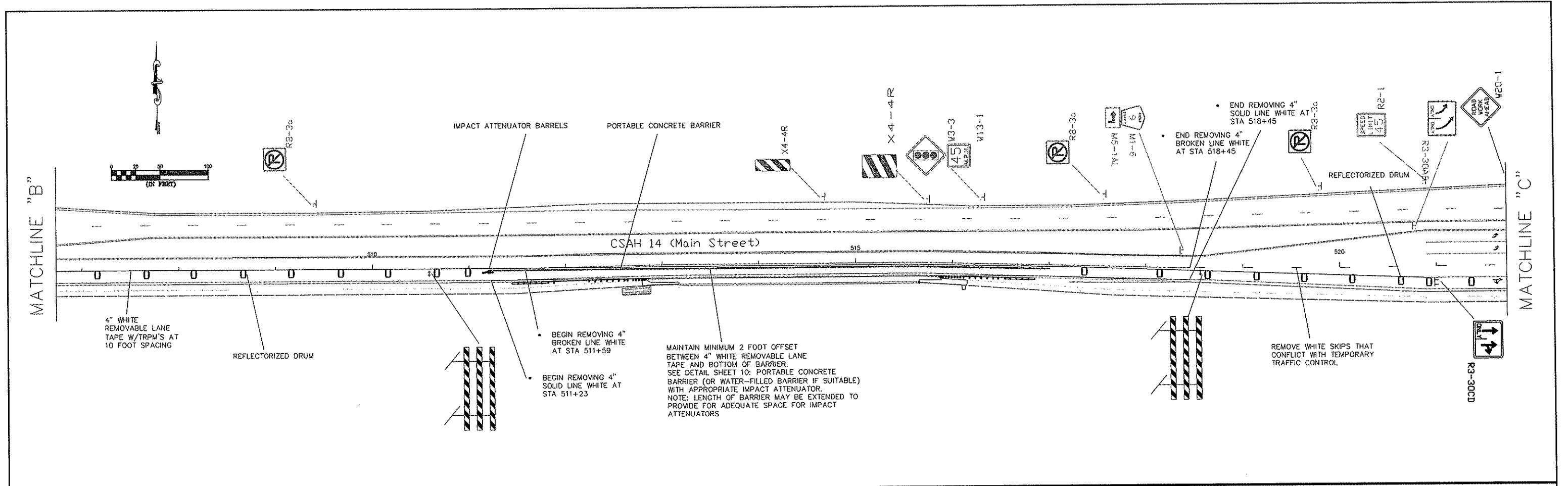

- Notes:
1. ALL TRAFFIC CONTROL DEVICES SHALL CONFORM TO THE MOST RECENT EDITION OF THE MINNESOTA MANUAL ON UNIFORM TRAFFIC CONTROL DEVICES INCLUDING THE FIELD MANUAL, DATED JANUARY, 2007.
  2. ALL TYPE III BARRICADES SHALL BE REFLECTORIZED ON BOTH SIDES. BARRICADE MARKINGS SHALL BE SLANTED IN ACCORDANCE WITH THE M.U.T.C.D.
  3. EXISTING STRIPING AND SIGNING THAT CONFLICTS WITH THE CONSTRUCTION TRAFFIC CONTROL SHALL BE REMOVED OR MODIFIED.
  4. FOR DAYTIME LANE CLOSURES REFER TO THE FIELD MANUAL DATED JANUARY, 2007.

I HEREBY CERTIFY THAT THIS PLAN WAS PREPARED BY ME OR UNDER MY DIRECT SUPERVISION AND THAT I AM A DULY LICENSED PROFESSIONAL ENGINEER UNDER THE LAWS OF THE STATE OF MINNESOTA. PRINT NAME: CURT A. KOBILARCSIK SIGNATURE: <i>Curt Kobilarsik</i> DATE: 12-9-10 LICENSE NO. 24756					DRAWN BY: MTH DATE 05/27/10 DESIGN BY: MTH DATE 05/27/10 CHECKED BY: RB DATE 6/01/10	<b>ANOKA COUNTY</b> <b>HIGHWAY DEPT.</b>	STATE AID PROJECT NO. 02-614-37 COON RAPIDS PROJECT NO. 06-48 MN STATE PROJECT NO. 114-20-40	<b>TRAFFIC CONTROL</b> Sheet 08 of 51 Sheets	
NO	DATE	BY	CKD	APPR	REVISION				

NAME: P:\14\_PED\Base\TRAFFIC\14\_Ped\_Traffic\_Control.dwg

SIGN PANELS TYPE					
M. U. T. C. D. CODE	SIZE	PANEL AREA FT. <sup>2</sup>	INSERT	QUANTITY	Notes
R3-X1	30' x 30'	6.25		1	
R3-30CD	36' x 30'	7.50		1	
W20-1	48' x 48'	16.00		6	
W21-XSR	48' x 48'	16.00		2	
W20-X3L	48' x 48'	16.00		4	
G20-2A	24' x 48'	8.00		2	
W1-6	48' X 24'	8.00		2	*1
	TYPE III BARRICADE			7	

SIGN PANELS TYPE					
M. U. T. C. D. CODE	SIZE	PANEL AREA FT. <sup>2</sup>	INSERT	QUANTITY	No. POST
V3-3	48' x 30'	10.00		5	*1
	TYPE III BARRICADE			5	
M1-6a	48' x 30'	10.00		2	*1
	TYPE III BARRICADE			2	
R9-3a	18' X 18'	2.25		2	*2
	REFLECTORIZED DRUM			68	

SPECIFIC NOTES:

- ① SIGN MOUNTED ON TYPE III BARRICADE
- ② SIGN MOUNTED ON TYPE III BARRICADE

General Notes:

1. ALL TRAFFIC CONTROL DEVICES SHALL CONFORM TO THE MOST RECENT EDITION OF THE MINNESOTA MANUAL ON UNIFORM TRAFFIC CONTROL DEVICES INCLUDING THE FIELD MANUAL DATED JANUARY, 2007.
2. ALL TYPE III BARRICADES SHALL BE REFLECTORIZED ON BOTH SIDES. BARRICADE MARKINGS SHALL BE SLANTED IN ACCORDANCE WITH THE M.U.T.C.D.
3. EXISTING STRIPING AND SIGNING THAT CONFLICTS WITH THE CONSTRUCTION TRAFFIC CONTROL SHALL BE REMOVED OR MODIFIED.
4. FOR DAYTIME LANE CLOSURES REFER TO THE FIELD MANUAL DATED JANUARY, 2007.

TEMPORARY PAVEMENT MARKINGS				
STAGE	WHITE TRPM EACH	REMOVE PAVEMENT MARKING TEMPORARY LIN FT	TEMPORARY LANE MARKING WHITE LIN FT	NOTES
CONSTRUCTION STAGE 1	300	160	2993	
<b>TOTALS</b>	<b>300</b>	<b>160</b>	<b>2993</b>	

NOTES:

Merge traffic to left through lane. Close right through lane to complete sidewalk construction.  
Temporary Pavement Marking Removal, Temporary Lane Marking and TRPM's are incidental to Traffic Control.



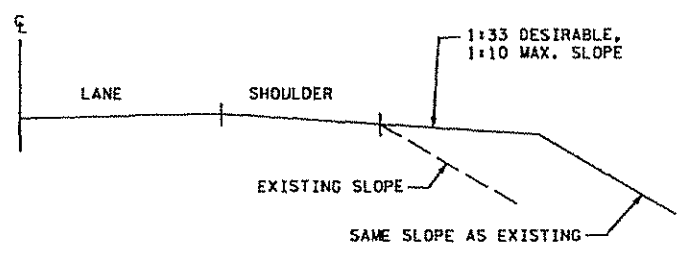
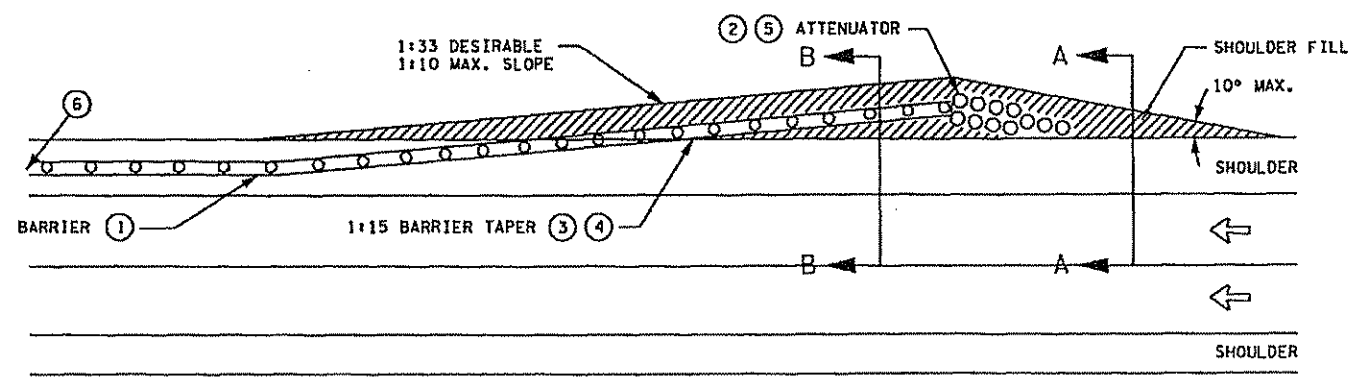

SECTION A-A

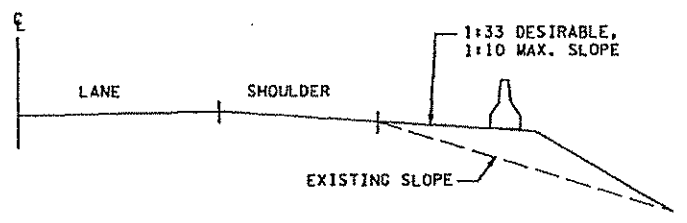

SECTION B-B

- ① IT IS DESIRABLE TO MAINTAIN FULL SHOULDER WIDTH WHENEVER POSSIBLE. IF NOT POSSIBLE, MINIMUM DESIRABLE LATERAL OFFSETS ARE BASED ON THE FOLLOWING POSTED SPEEDS:  
 70 MPH - 12.0 FEET  
 60 MPH - 8.0 FEET  
 50 MPH - 6.5 FEET  
 40 MPH - 5.0 FEET  
 FOR RESTRICTED CONDITIONS, LESSER OFFSETS MAY BE USED. THE OFFSETS SHOULD BE A MINIMUM OF 2 FEET UNLESS THE CONDITIONS ARE EXTREME. LATERAL OFFSETS ARE MEASURED TO THE BOTTOM OF THE BARRIER. BARRIER OFFSET FROM EDGE OF THRU LANE SHOULD NOT EXCEED 15 FEET.
  - ② DESIRABLE TREATMENTS FOR EXPOSED BARRIER ENDS ARE; A CONNECTION TO EXISTING BARRIER; IMPACT ATTENUATOR; TAPER AWAY TO THE EDGE OF THE CLEAR ZONE; AND EXTENDING THROUGH A PLATE BEAM GUARDRAIL BY REMOVING A PANEL.
  - ③ A 1:10 TAPER MAY BE USED WHEN POSTED SPEED LIMIT IS 35 MPH OR LESS.
  - ④ IF THE BARRIER IS TO BE EXTENDED BEYOND THE SHOULDER, ADDITIONAL FILL WILL BE NEEDED IN ORDER TO PROVIDE A FLAT (1:33) APPROACH AREA TO THE BARRIER. FILL WILL BE INCIDENTAL TO BARRIER AND/OR IMPACT ATTENUATOR.
  - ⑤ THE IMPACT ATTENUATOR SHOULD BE OFFSET A MINIMUM OF 2 FT. FROM THE EDGE OF THE THRU LANE (SEE SAND BARREL OFFSET DETAIL). THE IMPACT ATTENUATOR SHOULD BE ORIENTED TO ACCOMMODATE THE PROBABLE IMPACT ANGLE OF AN ENCROACHING VEHICLE. FOR MOST ROADSIDE CONDITIONS, AN ANGLE APPROXIMATELY 10 DEGREES, AS MEASURED BETWEEN THE HIGHWAY AND THE IMPACT ATTENUATOR LONGITUDINAL CENTERLINE, IS CONSIDERED APPROPRIATE.
  - ⑥ FOR TWO LANE, TWO WAY TRAFFIC BOTH ENDS OF THE BARRIER SHOULD BE TREATED IN THE SAME MANNER AS DESCRIBED IN ②.
- NOTE:  
 AT THE DIRECTION OF THE ENGINEER, OTHER APPROVED IMPACT ATTENUATORS CAN BE SUBSTITUTED IN LIEU OF THE SAND BARRELS ESPECIALLY WHERE REDIRECTION IS DESIRED OR AT WIDTH RESTRICTED AREAS.

SEE LAYOUT 19A FOR BARREL ARRAY SET UP.

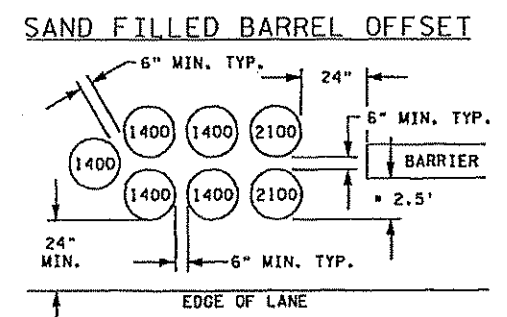
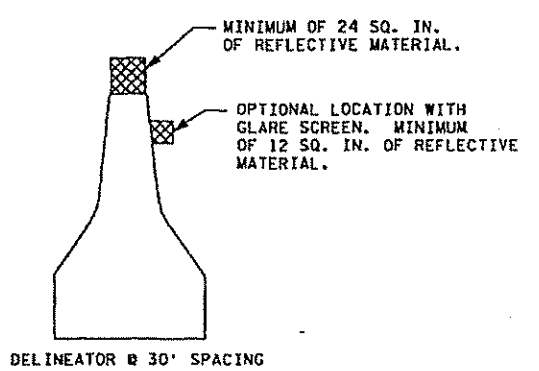

NOTE:  
 • DISTANCE MAY BE REDUCED TO MINIMUM OF 15 IN. THIS IS ACCEPTABLE ONLY WHERE A GREATER OFFSET WOULD CAUSE UNACCEPTABLE INTERFERENCE WITH TRAFFIC.

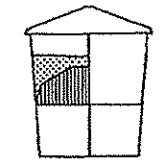

SEE MANUFACTURER INFORMATION FOR PROPER PROCEDURE TO FILL BARRELS WITH SAND.

PORTABLE CONCRETE BARRIER PLACEMENT AND END TREATMENT

9/20/05 LAYOUT 19.DGN

I HEREBY CERTIFY THAT THIS PLAN WAS PREPARED BY ME OR UNDER MY DIRECT SUPERVISION AND THAT I AM A DULY REGISTERED PROFESSIONAL ENGINEER UNDER THE LAWS OF THE STATE OF MINNESOTA.					DRAWN BY: MTH DATE 10/15/10		<b>ANOKA COUNTY HIGHWAY DEPT.</b>	STATE AID PROJECT NO. 02-614-37	PORTABLE CONCRETE BARRIER PLACEMENT AND END TREATMENT DETAILS
PRINT NAME: CURT A. KOBILARCSIK					DESIGN BY: MTH DATE 10/15/10			COON RAPIDS PROJECT NO. 06-48	
SIGNATURE: <i>Curt Kobilarcsik</i>					CHECKED BY: JR DATE 10/15/10	MN STATE PROJECT NO. 114-20-40		Sheet 10 of 51 Sheets	
NO	DATE	BY	CKD	APPR	REVISION	NAME: P:\02-596-11\Bose\Traffic\SIGN&STRPE_DETAILS.DWG			

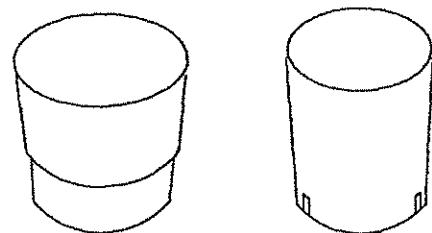

Model 640

Model 960



Model 90/180 cone



Model 320 cone



Lid

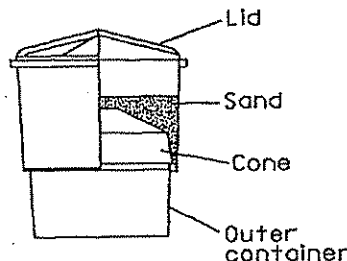

NOMINAL MASS		OUTER CONTAINER MODEL	CONE MODEL	LID	FILL HEIGHT FROM TOP (INCHES)
kg	lbs				
90	200	640	90/180	X	8.5
180	400	640	90/180	X	5
320	700	640	320	X	4
640	1400	640	-	X	3
960	2100	960	-	X	0

www.energyabsorption.com

### ENERGITE III

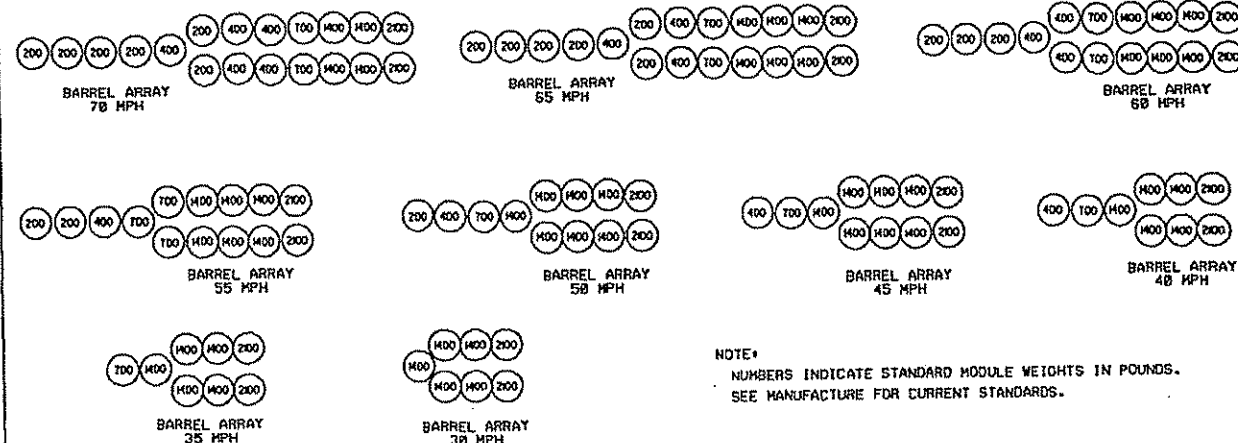

NOTE: NUMBERS INDICATE STANDARD MODULE WEIGHTS IN POUNDS. SEE MANUFACTURE FOR CURRENT STANDARDS.

### ENERGITe III

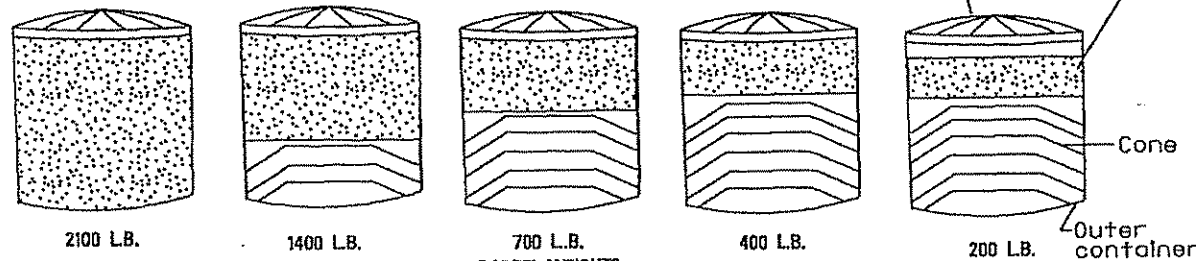

NOTE: CONES ARE INDIVIDUAL AND STACK TO HEIGHT REQUIRED BY MANUFACTURE FOR WEIGHT REQUIREMENTS (DRAWING DOES NOT REPRESENT CONE QUANTITIES)

NOMINAL MASS		FILL HEIGHT FROM TOP (INCHES)
kg	lbs	
90	200	12
180	400	8.5
320	700	6
640	1400	TOP
960	2100	TOP

www.energyabsorption.com

### FITCH

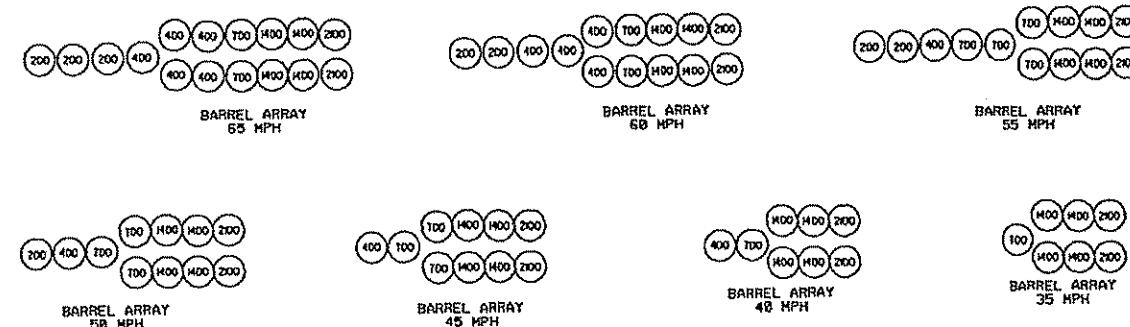

NOTE: NUMBERS INDICATE STANDARD MODULE WEIGHTS IN POUNDS. SEE MANUFACTURE FOR CURRENT STANDARDS.

### FITCH

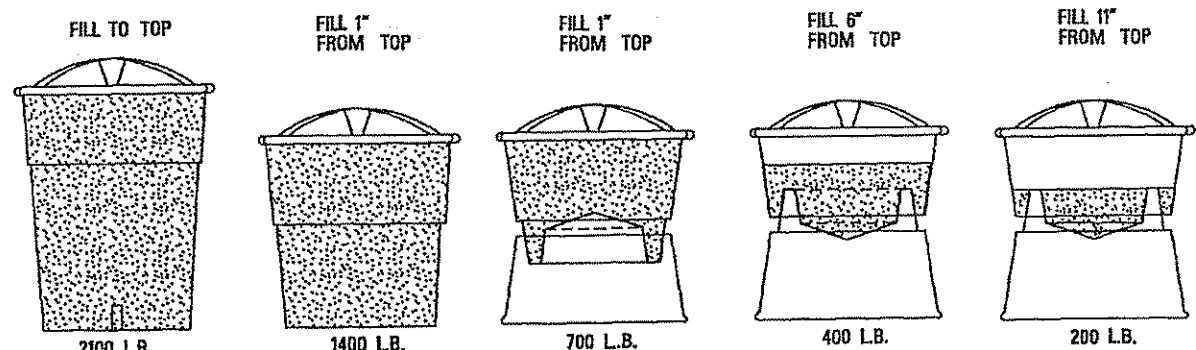

www.traffixdevices.com

BARREL WEIGHTS  
Traffix Devices, Inc.

### TRAFFIX

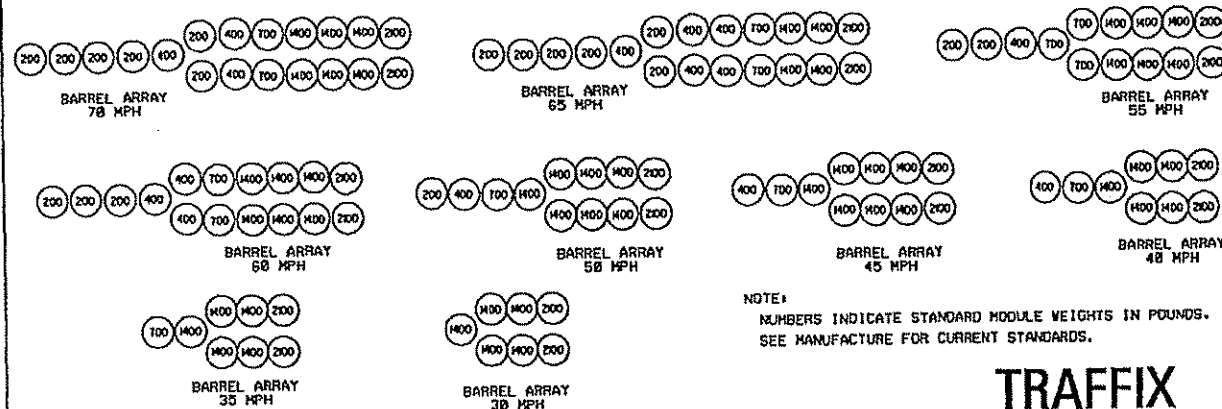

NOTE: NUMBERS INDICATE STANDARD MODULE WEIGHTS IN POUNDS. SEE MANUFACTURE FOR CURRENT STANDARDS.

### TRAFFIX

I HEREBY CERTIFY THAT THIS PLAN WAS PREPARED BY ME OR UNDER MY DIRECT SUPERVISION AND THAT I AM A DULY REGISTERED PROFESSIONAL ENGINEER UNDER THE LAWS OF THE STATE OF MINNESOTA.  
PRINT NAME: CURT A. KOBILARCSIK  
SIGNATURE: *Curt Kobilarsik*  
DATE: 12-9-10 REG. NO. 24756

DRAWN BY: MTH DATE 10/15/10  
DESIGN BY: MTH DATE 10/15/10  
CHECKED BY: JR DATE 10/15/10



ANOKA COUNTY  
HIGHWAY DEPT.

STATE AID PROJECT NO. 02-614-37  
COON RAPIDS PROJECT NO. 06-48  
MN STATE PROJECT NO. 114-20-40

PORTABLE CONCRETE  
BARRIER AND END  
TREATMENT DETAILS

Sheet 11 of 51 Sheets

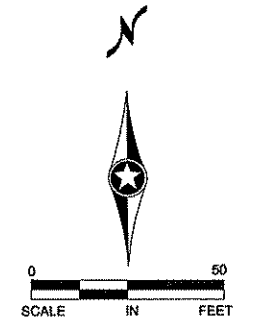
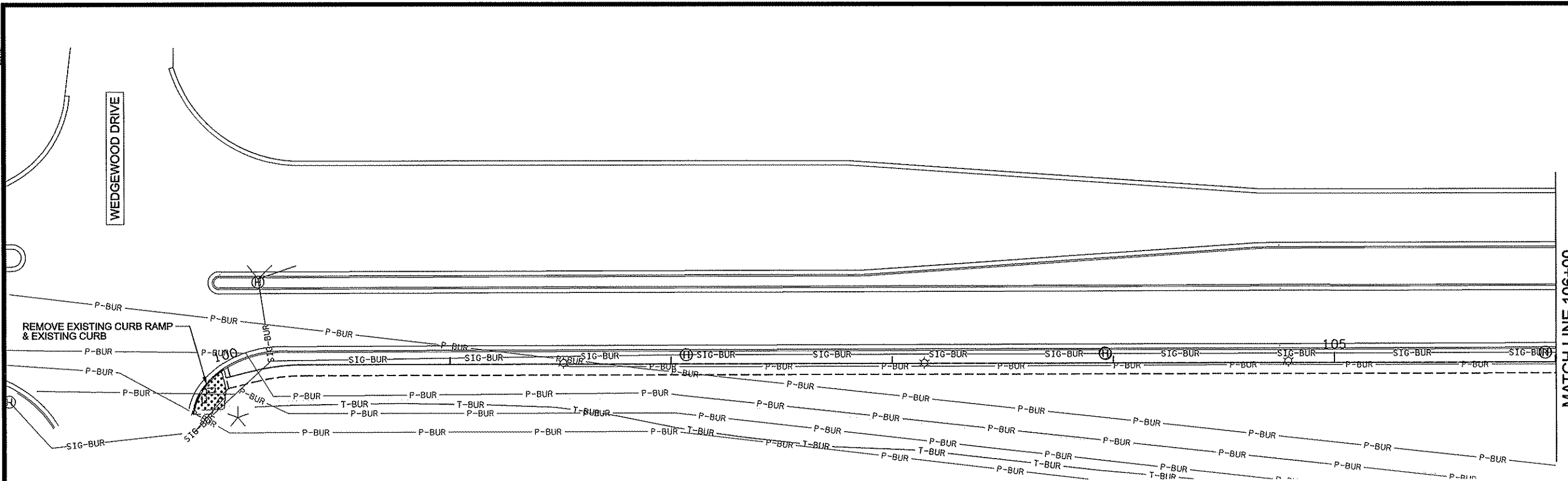

**REMOVAL NOTES**

ALL PRIVATE UTILITIES TO BE RELOCATED BY OTHERS AS REQUIRED. SEE IN PLACE UTILITY TABULATION FOR MORE INFORMATION.

**NOTES:**

ALL ROADWAY SIGNS WITHIN THE CONSTRUCTION LIMITS AND CONFLICTING SIGNS SHALL BE SALVAGED BY THE CONTRACTOR UNLESS OTHERWISE NOTED.

(A) SAWCUT BITUMINOUS PAVEMENT (FULL DEPTH)

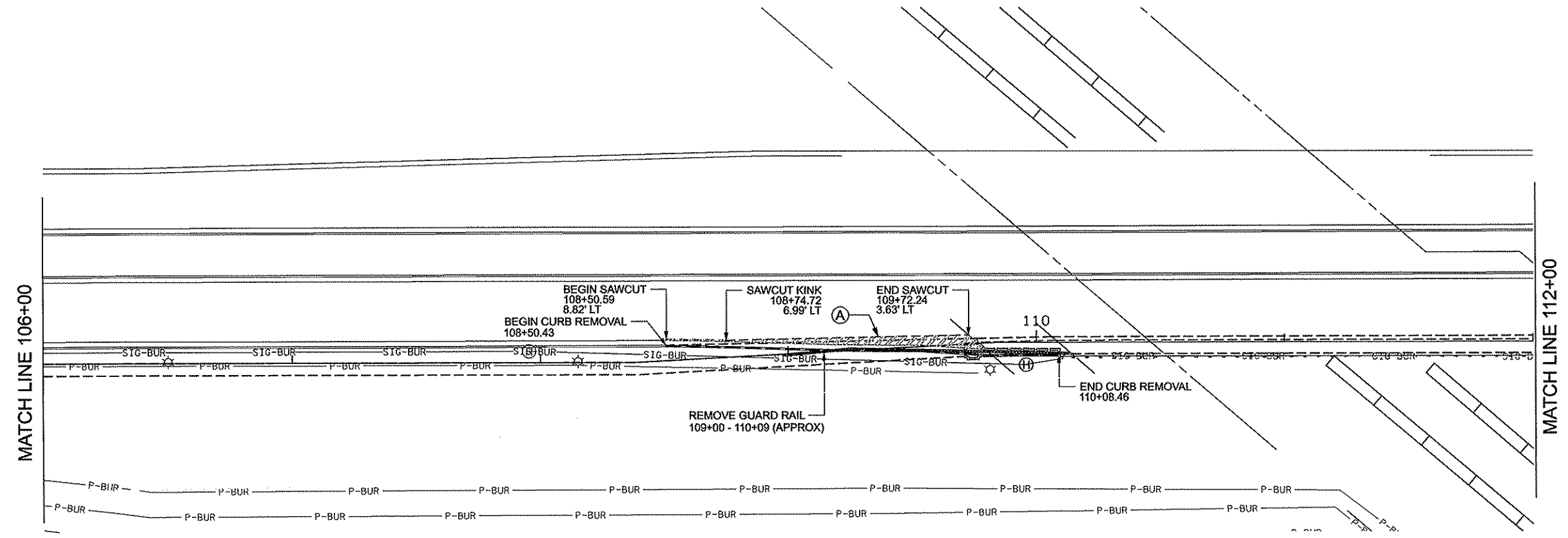

**LEGEND**

- REMOVE BITUMINOUS PAVEMENT
- REMOVE CONCRETE
- PROPOSED GEOMETRICS
- REMOVE CURB AND GUTTER
- SAWING BITUMINOUS PAVEMENT
- CONSTRUCTION LIMIT
- RAILROAD RW
- EXISTING RW
- PROPOSED TRAIL
- BURIED POWER
- BURIED TELE
- BURIED SIGNAL
- BURIED GAS
- OH POWER

SEE PAGE 4 FOR UTILITY & REMOVAL NOTES

NO	DATE	BY	CKD	APPR	REVISION

NAME: p:\14\_ped\plan\14\_PED\_RM1.dgn      12/01/2010      2:14:10 PM

I HEREBY CERTIFY THAT THIS PLAN WAS PREPARED BY ME OR UNDER MY DIRECT SUPERVISION AND THAT I AM A DULY LICENSED PROFESSIONAL ENGINEER UNDER THE LAWS OF THE STATE OF MINNESOTA.

PRINT NAME: CURT A. KOBIARCSIK  
 SIGNATURE: *Curt Kobiarcsik*  
 DATE: 12-9-10      LICENSE NO. 24756

DRAWN BY: NJD      DATE: 10-28-10  
 DESIGN BY: NJD      DATE: 10-28-10  
 CHECKED BY: JEO      DATE: 11-29-10



STATE AID PROJECT NO. 02-614-37  
 COON RAPIDS CITY NO. 06-48  
 MN STATE PROJECT NO. 114-020-40

INPLACE UTILITIES & REMOVAL PLAN  
 STA 100+00.00 TO 112+00.00  
 Sheet 12 of 51 Sheets

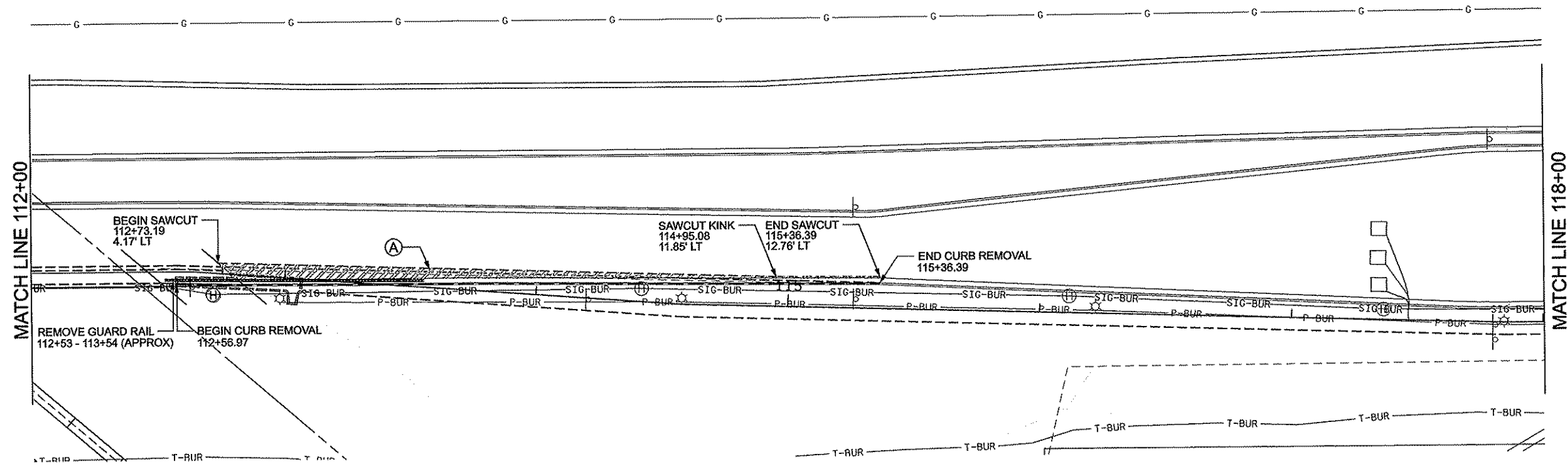

**REMOVAL NOTES**

ALL PRIVATE UTILITIES TO BE RELOCATED BY OTHERS AS REQUIRED. SEE IN PLACE UTILITY TABULATION FOR MORE INFORMATION.

ALL ROADWAY SIGNS WITHIN THE CONSTRUCTION LIMITS AND CONFLICTING SIGNS SHALL BE SALVAGED BY THE CONTRACTOR UNLESS OTHERWISE NOTED.

**NOTES:**

- (A) SAWCUT BITUMINOUS PAVEMENT (FULL DEPTH)

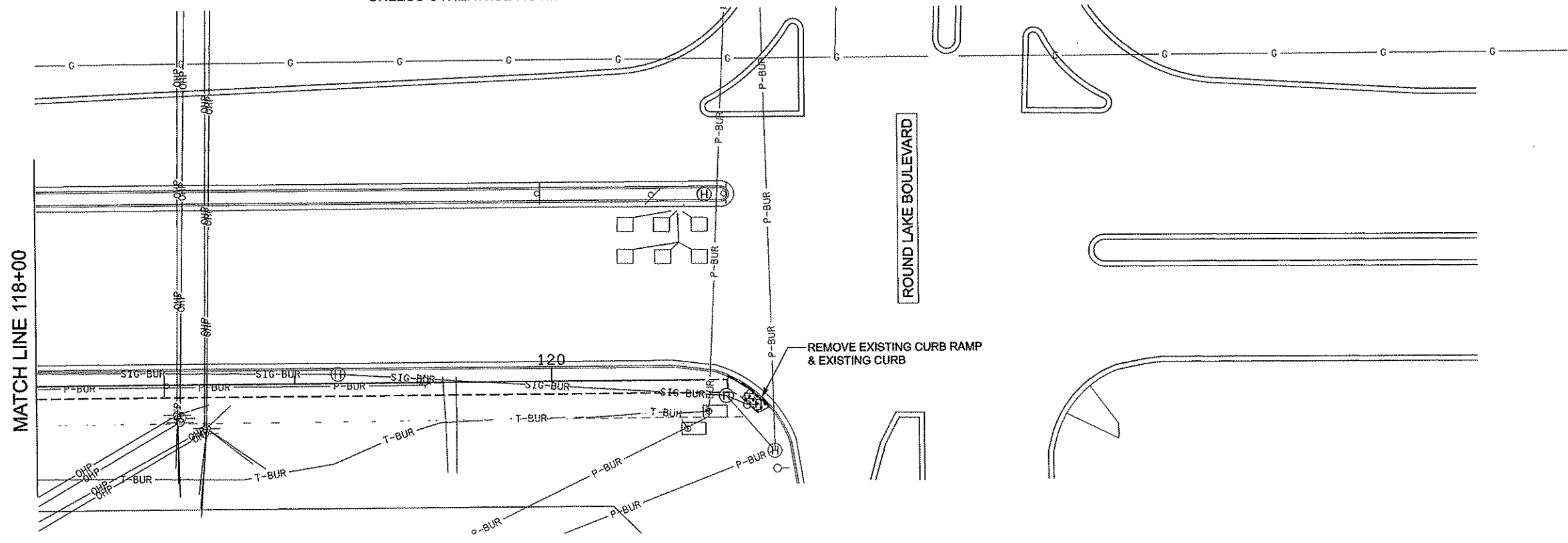
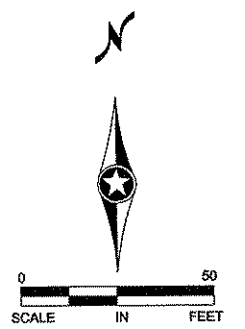

**LEGEND**

- REMOVE BITUMINOUS PAVEMENT
- REMOVE CONCRETE
- PROPOSED GEOMETRICS
- REMOVE CURB AND GUTTER
- SAWING BITUMINOUS PAVEMENT
- CONSTRUCTION LIMIT
- RAILROAD RW
- EXISTING RW
- PROPOSED TRAIL
- BURIED POWER
- BURIED TELE
- BURIED SIGNAL
- BURIED GAS
- OH POWER

SEE PAGE 4 FOR UTILITY & REMOVAL NOTES

NO	DATE	BY	CHKD	APPR	REVISION

NAME: p:\14\_ped\plan14\_PED\_RM2.dgn  
12/01/2010 2:14:15 PM

I HEREBY CERTIFY THAT THIS PLAN WAS PREPARED BY ME OR UNDER MY DIRECT SUPERVISION AND THAT I AM A DULY LICENSED PROFESSIONAL ENGINEER UNDER THE LAWS OF THE STATE OF MINNESOTA.

PRINT NAME: CURT A. KOBILARCSIK  
SIGNATURE: *Curt Kobilarsik*  
DATE: 12-9-10 LICENSE NO. 24756

DRAWN BY: NJD DATE: 10-28-10  
DESIGN BY: NJD DATE: 10-28-10  
CHECKED BY: JEO DATE: 11-29-10

**ANOKA COUNTY HIGHWAY DEPT.**

STATE AID PROJECT NO. 02-614-37  
COON RAPIDS CITY NO. 06-48  
MN STATE PROJECT NO. 114-020-40

**INPLACE UTILITIES & REMOVAL PLAN**  
STA 17+00.00 TO 25+62.77  
Sheet 13 of 51 Sheets

**PROPOSED SIDEWALK**  
 STA. 100+00.00 TO STA 109+70.63  
 STA. 113+06.59 TO STA 120+59.16

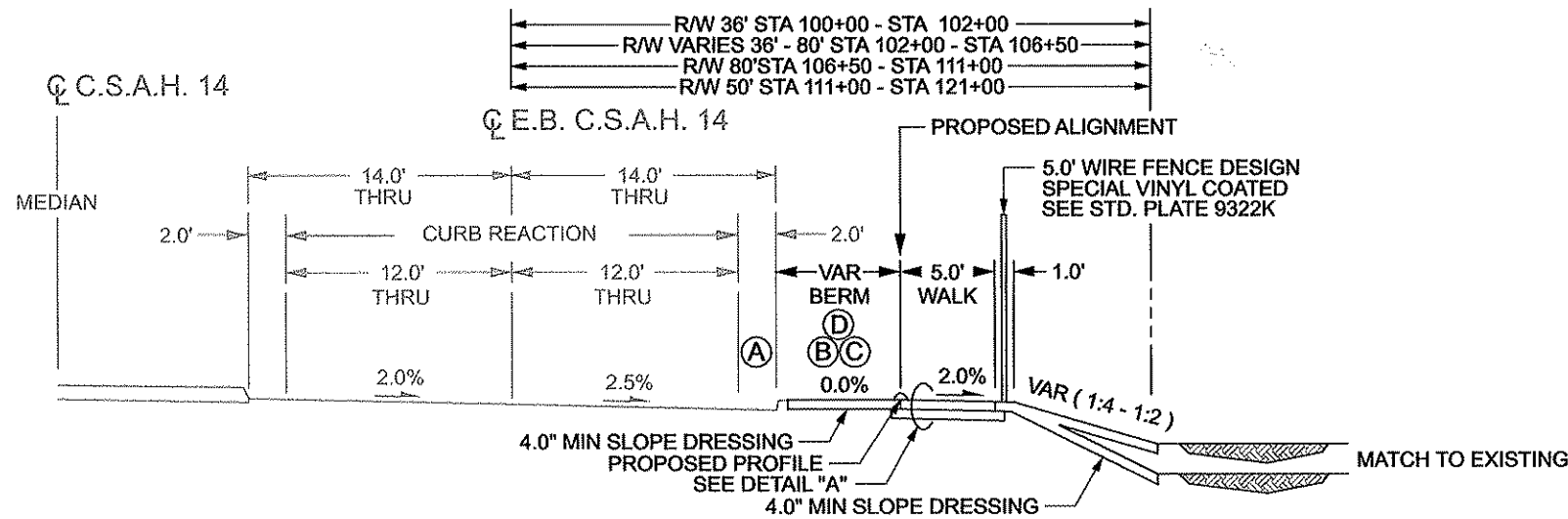

**PROPOSED BRIDGE APPROACH**  
 STA. 109+70.63 TO STA 110+08.46  
 STA. 112+56.97 TO STA 113+06.59

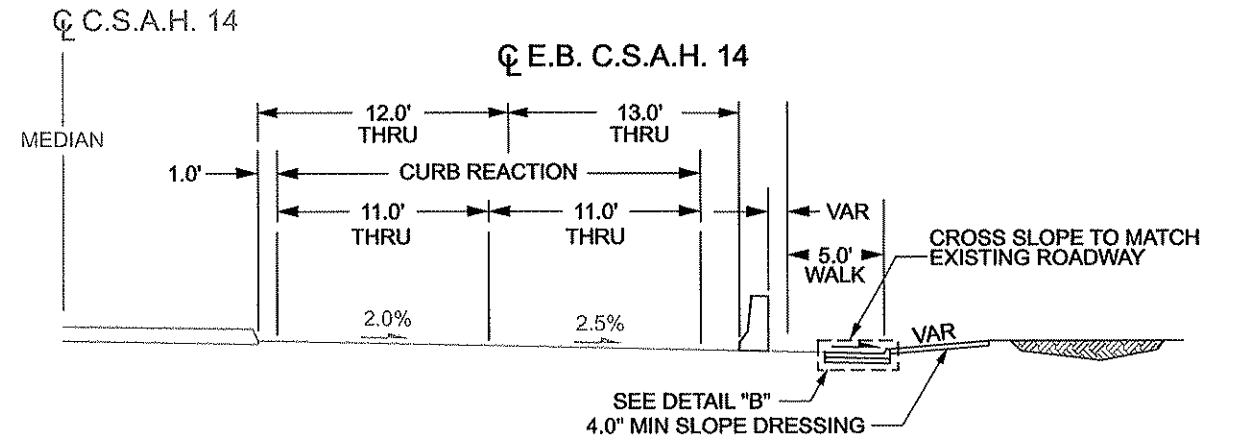

**PROPOSED BRIDGE SECTION**  
 STA. 110+08.46 TO STA 112+56.97

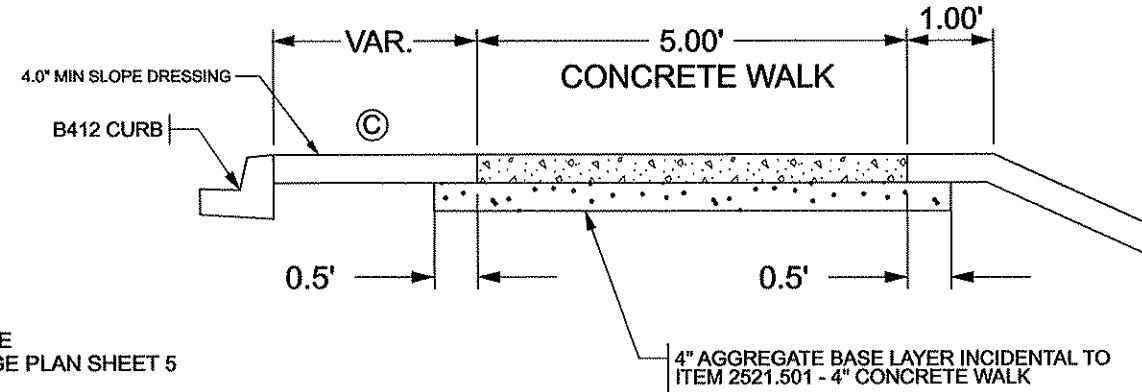
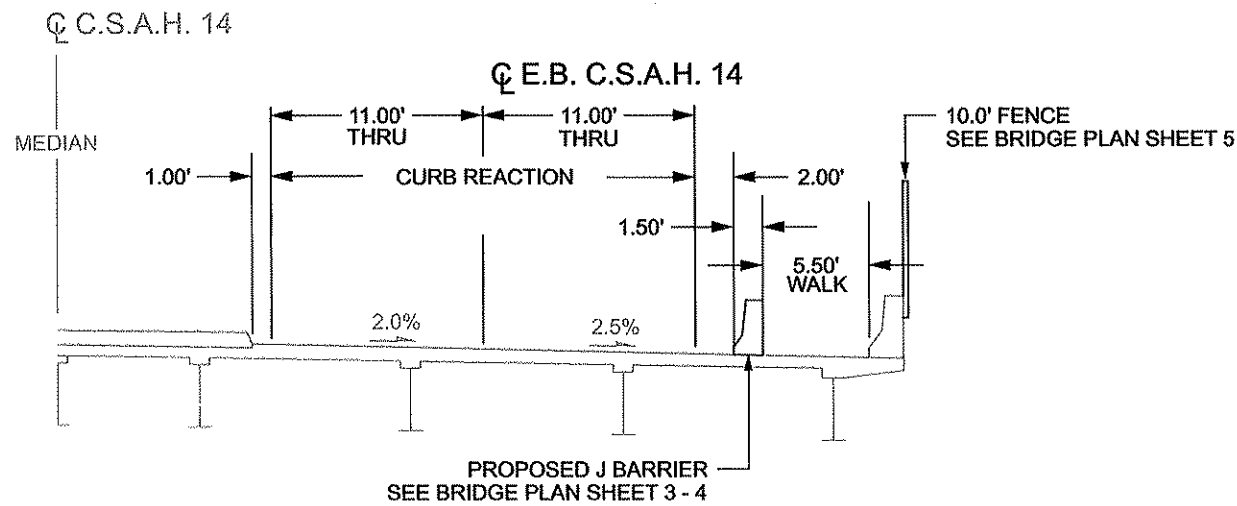

**DETAIL "A"**  
 CONCRETE WALK

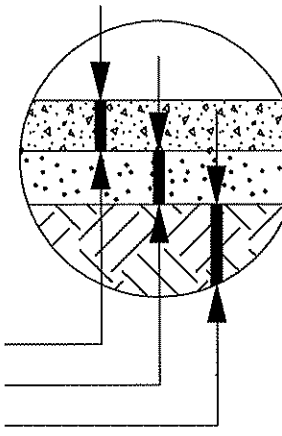

**DETAIL "B"**  
 CONCRETE WALK SPECIAL

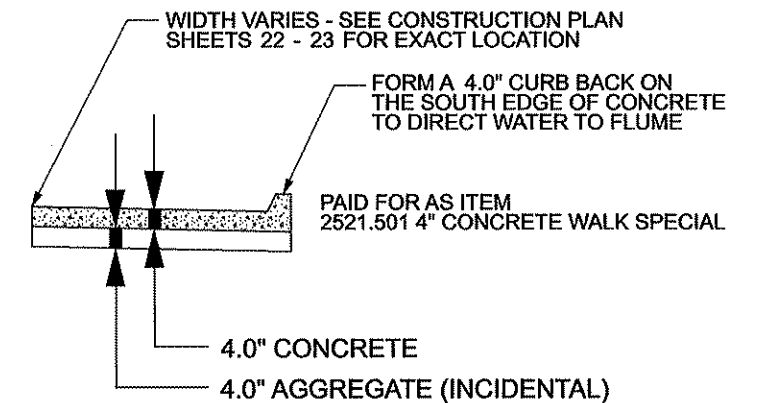

- Ⓐ B412 CURB STA. 108+50.43 TO STA. 109+75.53 AND STA. 112+75.08 TO STA. 115+36.39
- Ⓑ PROPOSED GUARD RAIL STA. 108+35.53 TO STA 109+75.53 AND STA. 112+75.12 TO STA. 113+75.12
- Ⓒ SOD TYPE SALT RESISTANT
- Ⓓ BERM WIDTH APPROX. 6' WIDE VARIES FROM STA. 108+38.36 TO STA 114+57.66

I HEREBY CERTIFY THAT THIS PLAN WAS PREPARED BY ME OR UNDER MY DIRECT SUPERVISION AND THAT I AM A DULY LICENSED PROFESSIONAL ENGINEER UNDER THE LAWS OF THE STATE OF MINNESOTA.  
 PRINT NAME: CURT A. KOBILARCSIK  
 SIGNATURE: *Curt A. Kobilarsik*  
 DATE: 12-9-10 LICENSE NO. 24756

DRAWN BY: NJD DATE: 8-19-10  
 DESIGN BY: NJD DATE: 5-28-10  
 CHECKED BY: JEO DATE: 11-28-10



**ANOKA COUNTY**  
**HIGHWAY DEPT.**

STATE AID PROJECT NO. 02-614-37  
 COON RAPIDS CITY NO. 06-48  
 MN STATE PROJECT NO. 114-020-40

TYPICAL SECTIONS



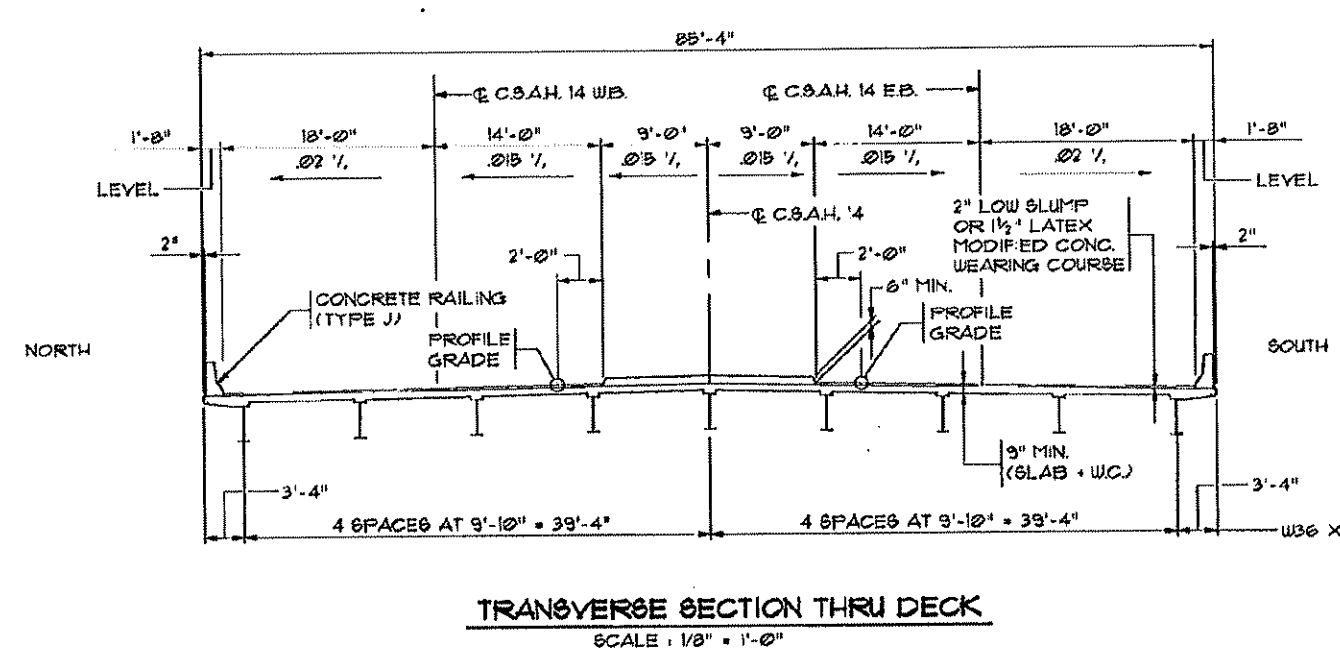
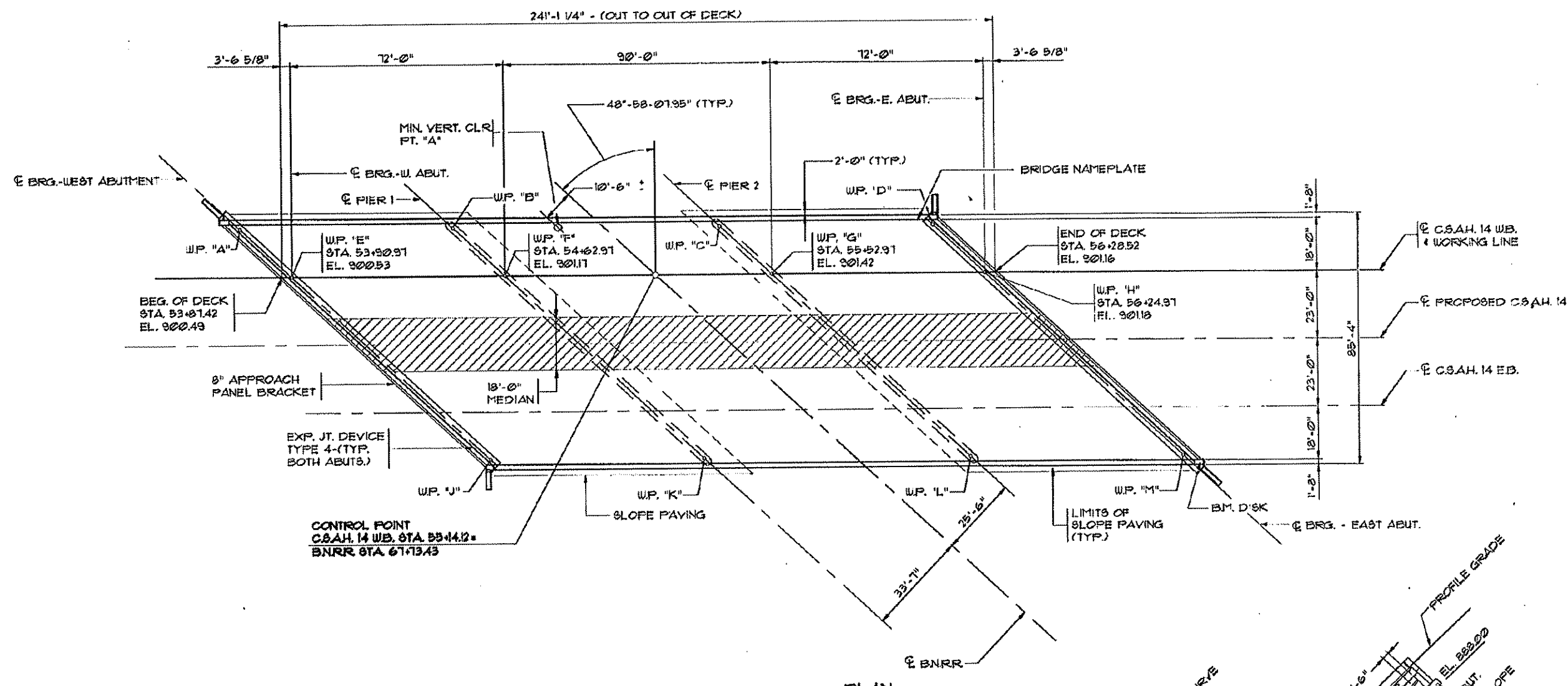

NOTE:  
CONSTRUCTION OF EACH ABUTMENT SHALL NOT BE STARTED UNTIL 72 HOURS AFTER THE APPROACH FILL HAS BEEN CONSTRUCTED TO THE FULL HEIGHT OF THE FILL AND CROSS SECTION.

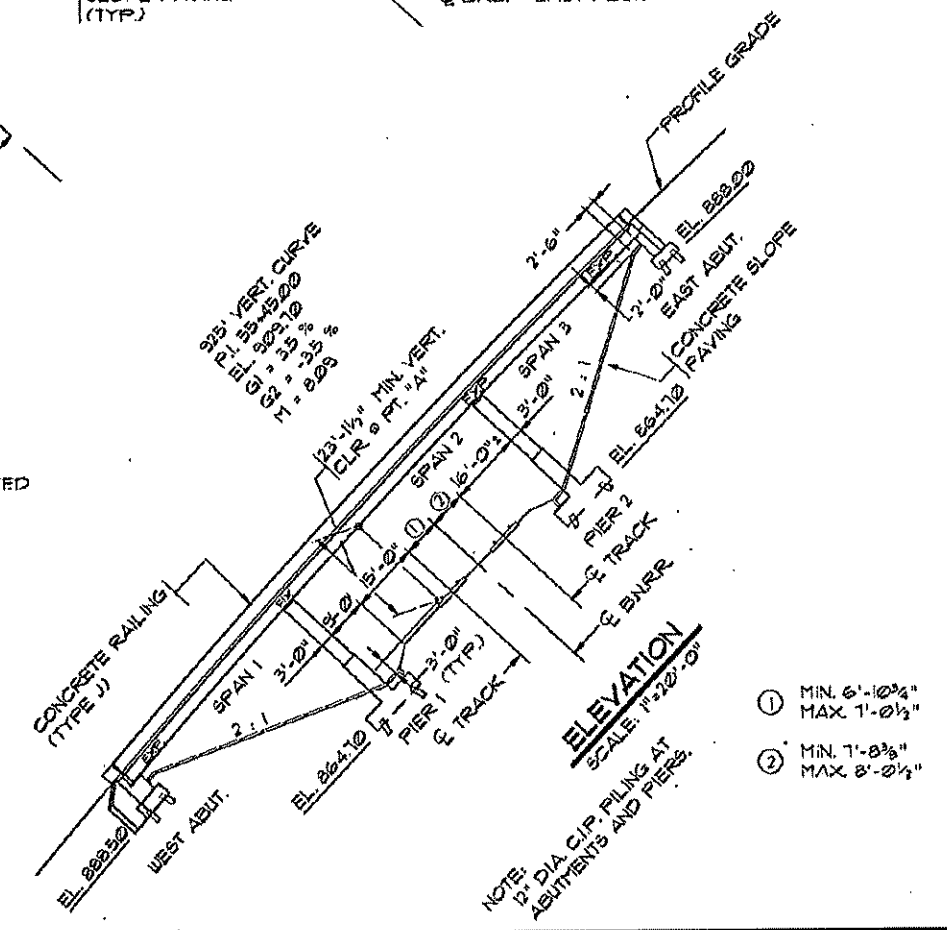

- ① MIN. 6'-10 3/4" MAX. 1'-0 1/2"
- ② MIN. 1'-0 3/8" MAX. 8'-0 1/2"

NO	DATE	BY	CKD	APPR	REVISION

NAME: P:\14\_PED\Plan\14\_PED\_XBR1.dgn      12/09/2010      11:12:34 AM

FOR INFORMATION ONLY





ANOKA COUNTY  
HIGHWAY DEPT.

STATE AID PROJECT NO. 02-614-37  
COON RAPIDS CITY NO. 06-48  
MN STATE PROJECT NO. 114-020-40

EXISTING BRIDGE PLAN

**LEGEND**

-  EXISTING CURB
-  CONCRETE WALK
-  CONCRETE WALK SPECIAL

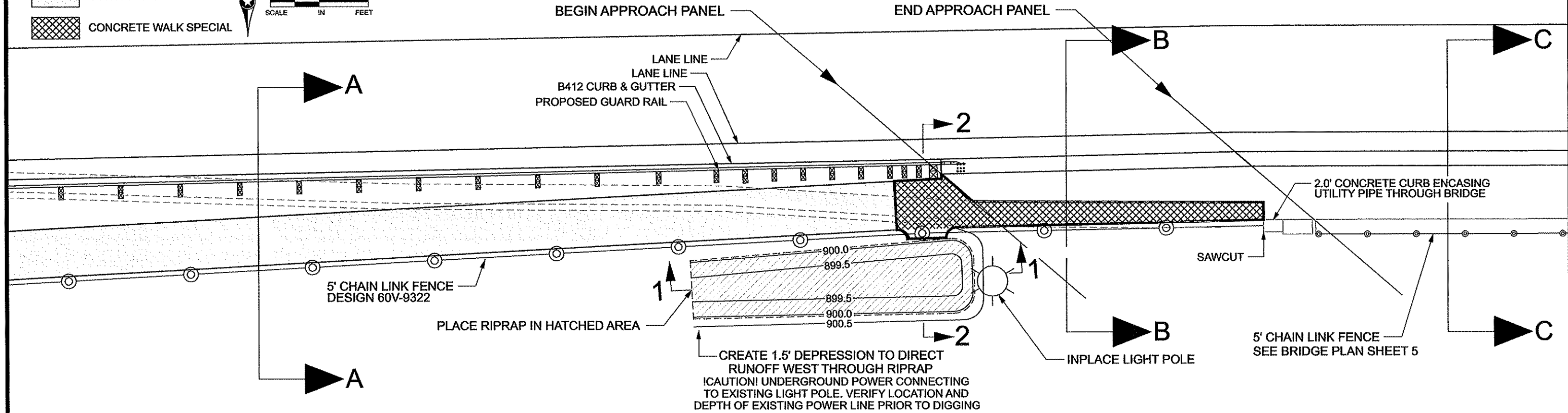
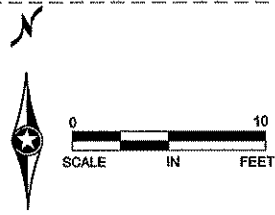

**SECTION A-A**

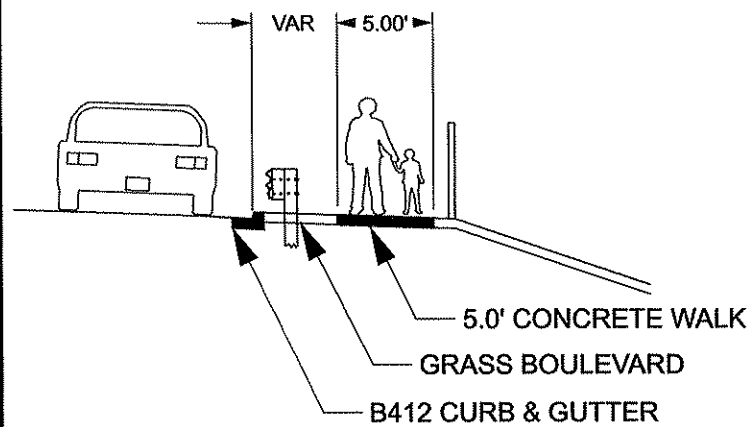

**SECTION B-B**

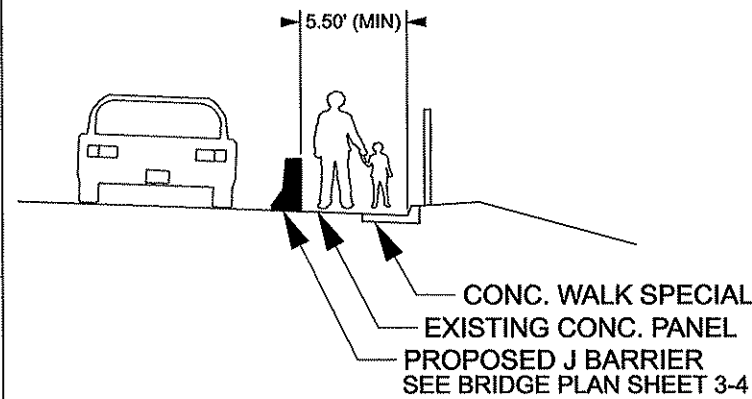

**SECTION C-C**

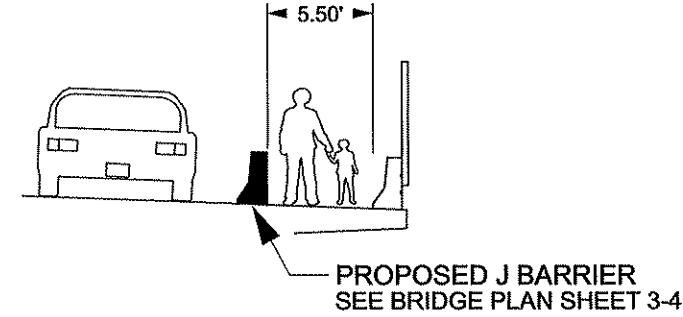

**SECTION 1-1**

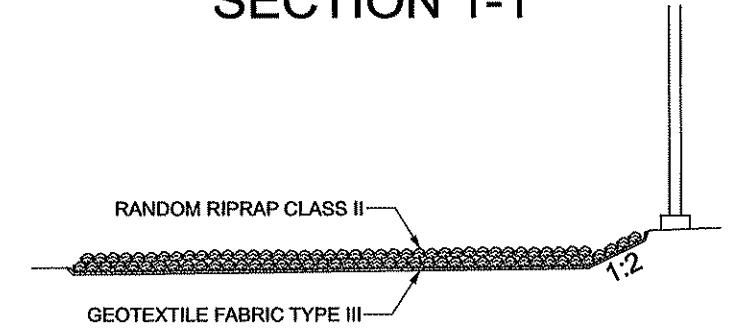

**SECTION 2-2**

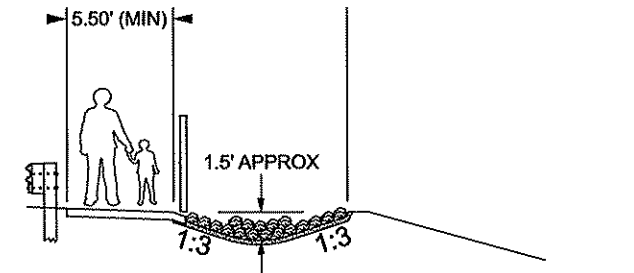

1 OF 2

NO	DATE	BY	CHKD	APPR	REVISION

NAME: P:\14\_PED\Plan14\_PED\_PPDT.dgn 12/09/2010 11:00:37 AM

I HEREBY CERTIFY THAT THIS PLAN WAS PREPARED BY ME OR UNDER MY DIRECT SUPERVISION AND THAT I AM A DULY LICENSED PROFESSIONAL ENGINEER UNDER THE LAWS OF THE STATE OF MINNESOTA.

PRINT NAME: CURT A. KOBILARCSIK

SIGNATURE: *Curt Kobilarsik*

DATE: 12-9-10 LICENSE NO. 24756

DRAWN BY: NJD DATE: 9-7-10

DESIGN BY: NJD DATE: 9-7-10

CHECKED BY: JEO DATE: 11-29-10



**ANOKA COUNTY  
HIGHWAY DEPT.**

STATE PROJECT NO. 02-614-37

STATE AID PROJECT NO. 06-48.

CITY PROJECT NO. 114-020-40

COUNTY PROJECT NO. \_\_\_\_\_

APPROACH DETAIL

Sheet 16 of 51 Sheets

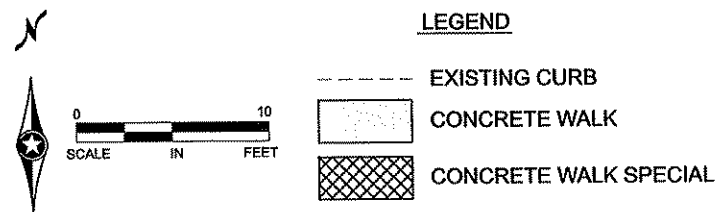
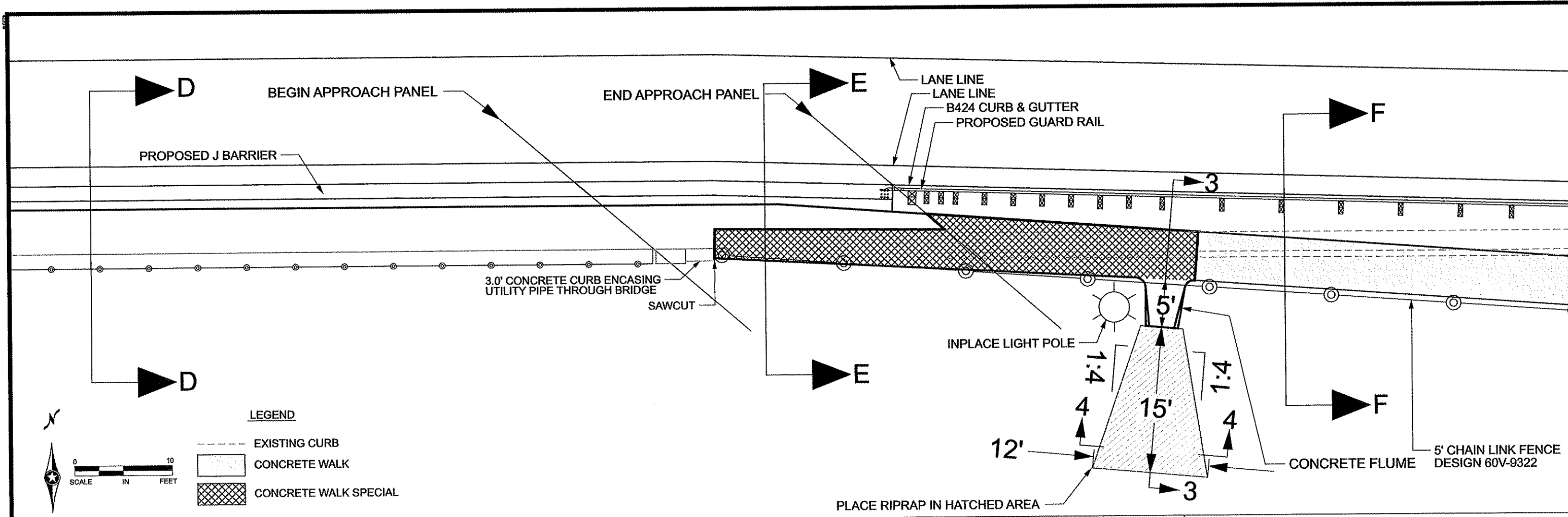

SECTION D-D

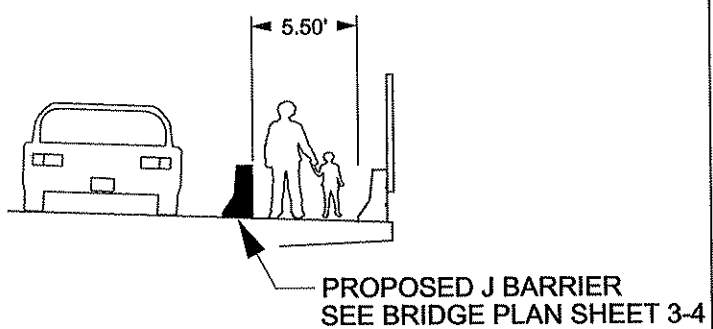

SECTION E-E

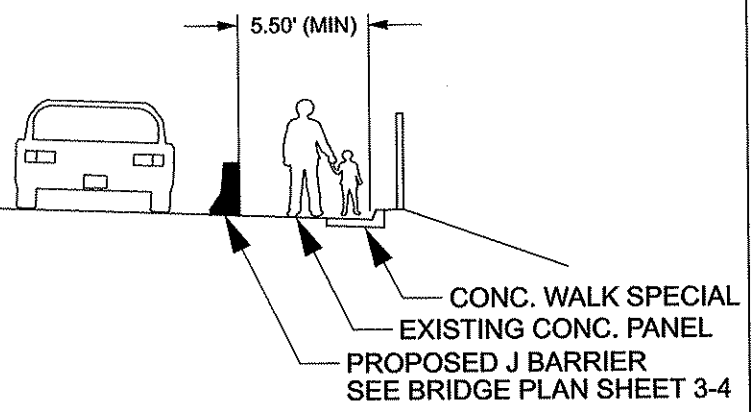

SECTION F-F

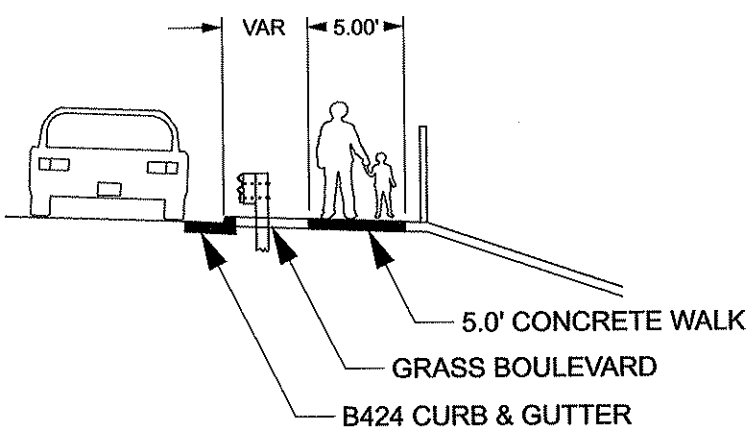

SECTION 3-3

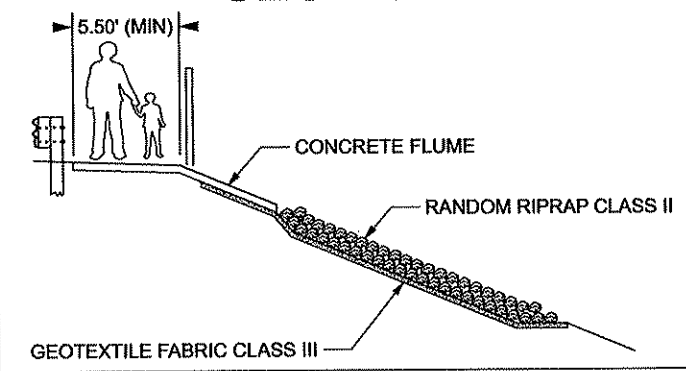

SECTION 4-4

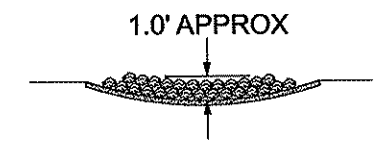

NO	DATE	BY	CKD	APPR	REVISION

NAME: P:\14\_PED\Plan\14\_PED\_PPDT2.dgn  
 12/09/2010 11:01:01 AM

I HEREBY CERTIFY THAT THIS PLAN WAS PREPARED BY ME OR UNDER MY DIRECT SUPERVISION AND THAT I AM A DULY LICENSED PROFESSIONAL ENGINEER UNDER THE LAWS OF THE STATE OF MINNESOTA.  
 PRINT NAME: CURT A. KOBILARCSIK  
 SIGNATURE: *Curt Kobilarsik*  
 DATE: 12-9-10 LICENSE NO. 24756

DRAWN BY: NJD DATE: 11-1-10  
 DESIGN BY: NJD DATE: 11-1-10  
 CHECKED BY: JEO DATE: 11-29-10

**ANOKA COUNTY**  
**HIGHWAY DEPT.**

STATE PROJECT NO. 02-614-37  
 STATE AID PROJECT NO. 06-48  
 CITY PROJECT NO. 114-020-40  
 COUNTY PROJECT NO.

APPROACH DETAIL  
 Sheet 17 of 51 Sheets

PLOTTED/REVISED:  
12/01/2010

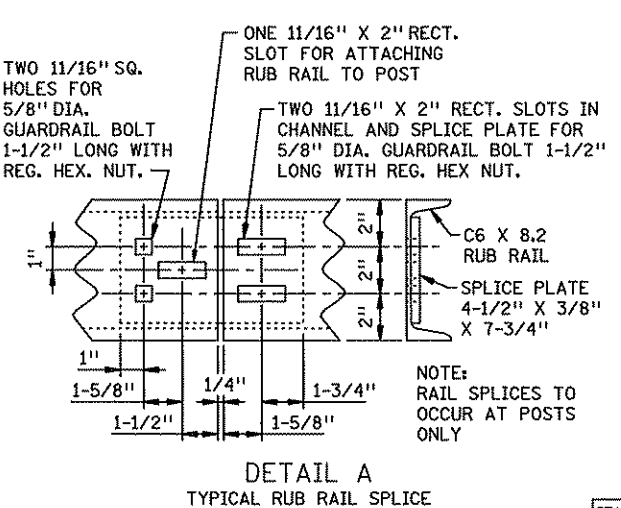
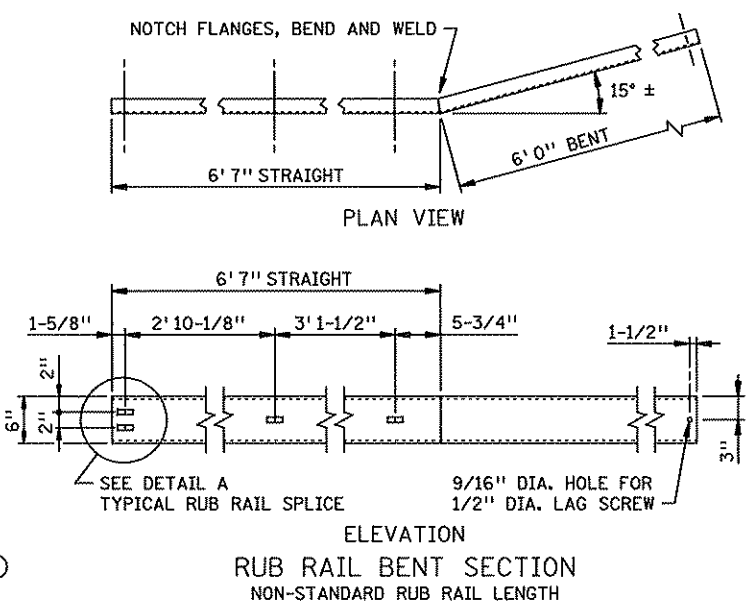
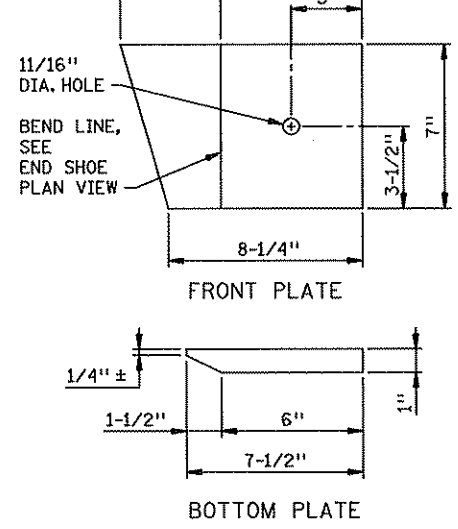
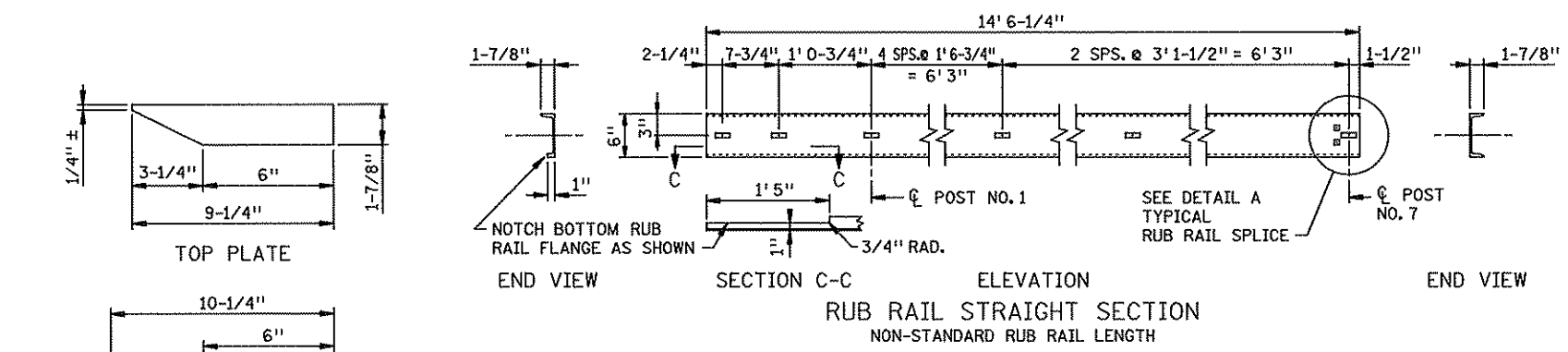
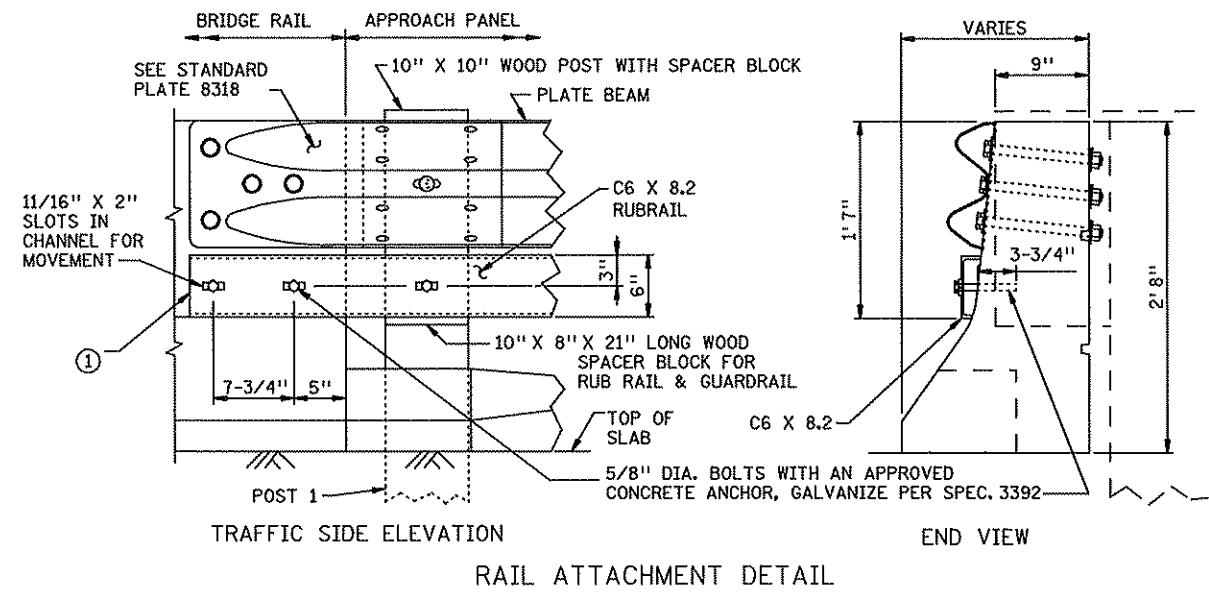
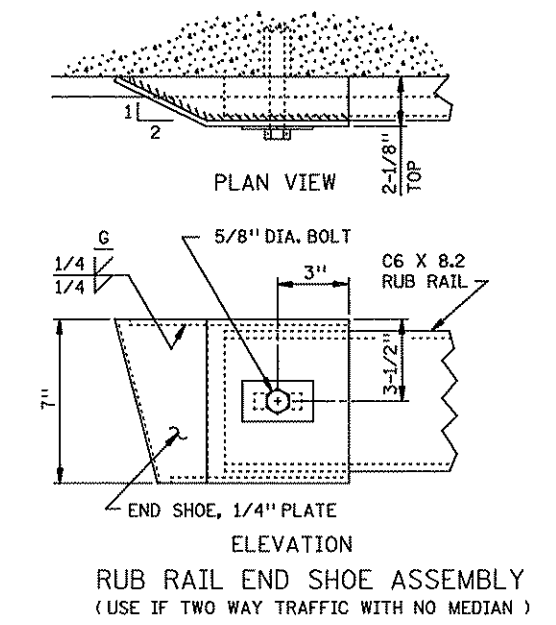
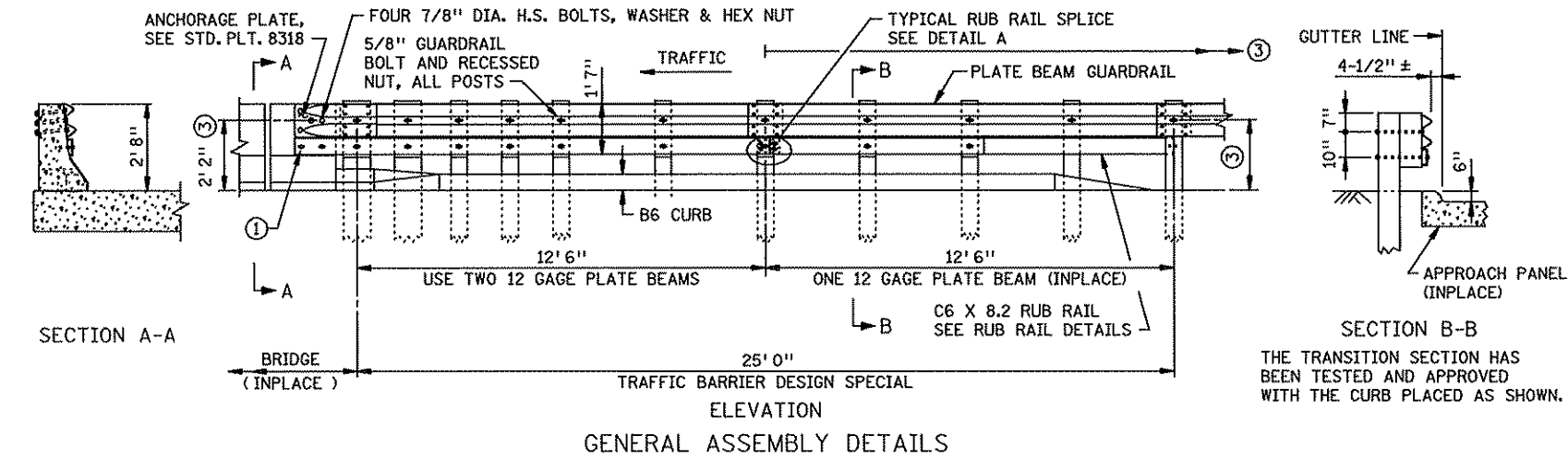
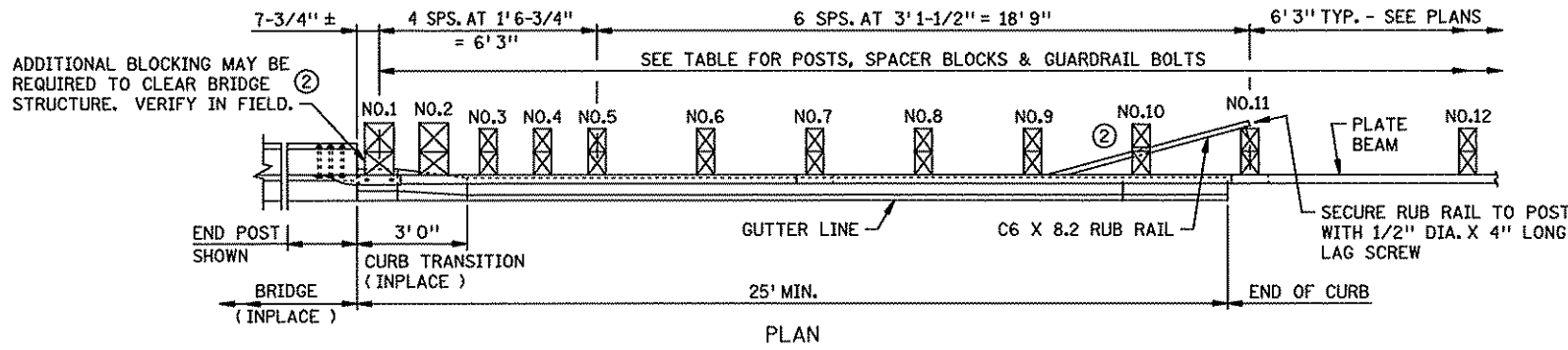

POST, SPACER BLOCK & BOLT TABLE

DESCRIPTION	POST NO.	SIZE
POST	1 & 2	10" X 10" X 8' 0" MIN. LONG
	3 - 5	6" X 8" X 7' 0" MIN. LONG
	6 - 12	6" X 8" X 6' 0" MIN. LONG
SPACER BLOCK	1 - 2	10" X 8" X 21"
	3 - 9	6" X 8" X 21"
GUARDRAIL BOLT & RECESSED NUT	1 - 2	5/8" DIA. X 20" - GUARDRAIL
	3 - 12	5/8" DIA. X 18" - GUARDRAIL
	1 - 2	5/8" DIA. X 22" - RUB RAIL
	3 - 9	5/8" DIA. X 20" - RUB RAIL

NOTES:  
 STRUCTURAL STEEL TO BE 3306, EXCEPT AS NOTED.  
 ALL SLOTTED HOLES ARE 11/16" X 2".  
 ALL SQUARE HOLES ARE 11/16".  
 RUB RAIL IS C6 X 8.2  
 GALVANIZE STRUCTURAL SHAPES PER SPEC. 3394 AFTER FABRICATION, EXCEPT AS NOTED.  
 MATERIALS AND CONSTRUCTION PER SPEC. 2554, EXCEPT AS NOTED.  
 GALVANIZE ALL HARDWARE PER SPEC. 3392.

- ① END SHOE REQUIRED IF TWO WAY TRAFFIC AND NO MEDIAN.
- ② ADDITIONAL BLOCKING MAY BE REQUIRED AT POST NO. 1 OR 10.
- ③ HEIGHT IS 2'2" FROM 0' TO 12'6" FROM BRIDGE. HEIGHT TAPERS FROM 2'2" TO 1'9" BETWEEN 12'6" TO 37'6" FROM BRIDGE.

TRAFFIC BARRIER DESIGN SPECIAL

STANDARD SHEET NO. 5-297.607	TITLE: NEW W-BEAM TRANSITION TO CONCRETE J-SHAPE SAFETY RAIL WITH APPROACH CURB (WOOD POST)
STANDARD APPROVED: DECEMBER 20, 2001	
REVISION DATE 2-12-03	STATE AID PROJECT NO. 02-614-37 SHEET NO. 18 OF 51 SHEETS

FILE NAME:  
@DGN\$

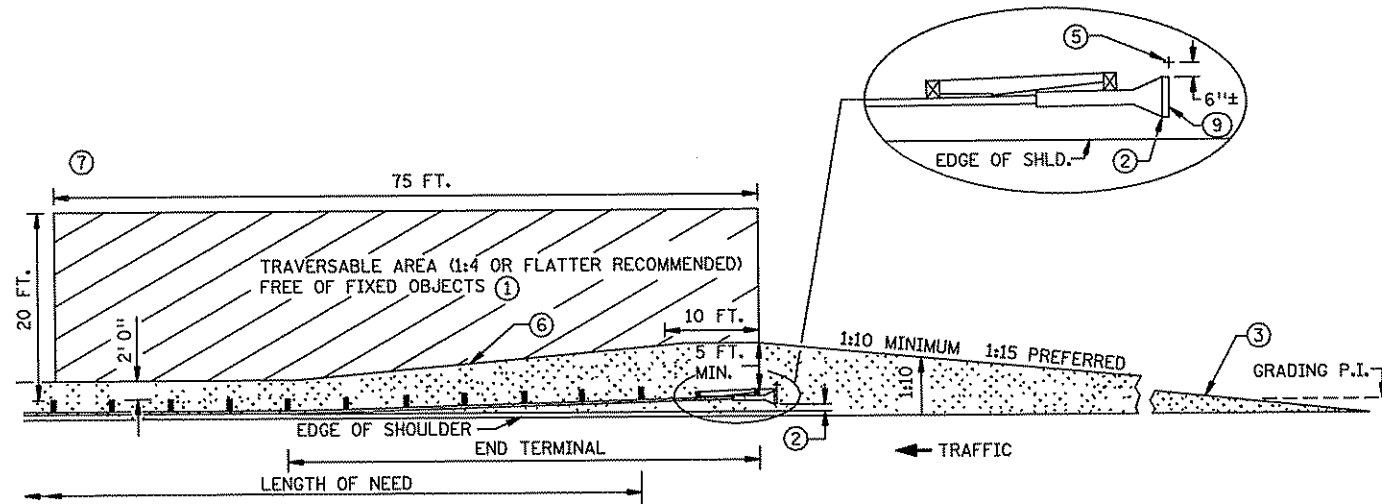

PLAN VIEW  
(PROPRIETARY TANGENT TERMINAL SHOWN AS EXAMPLE)

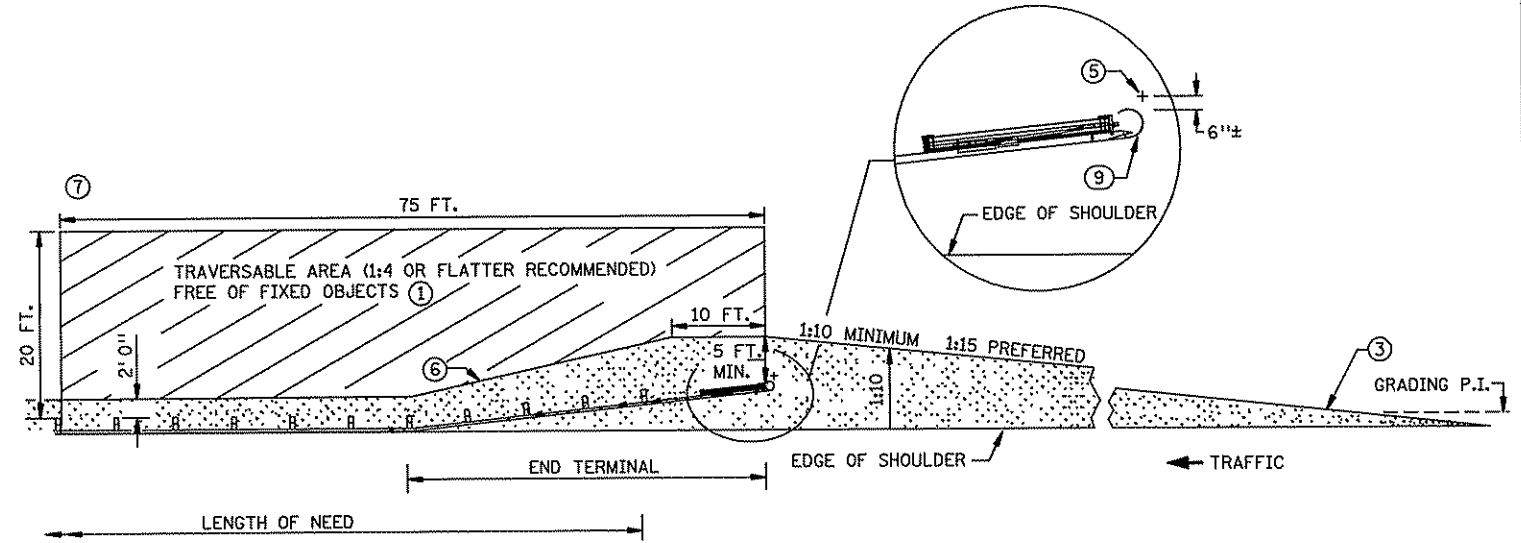

PLAN VIEW ⑧  
(PROPRIETARY FLARED TERMINAL SHOWN AS EXAMPLE)

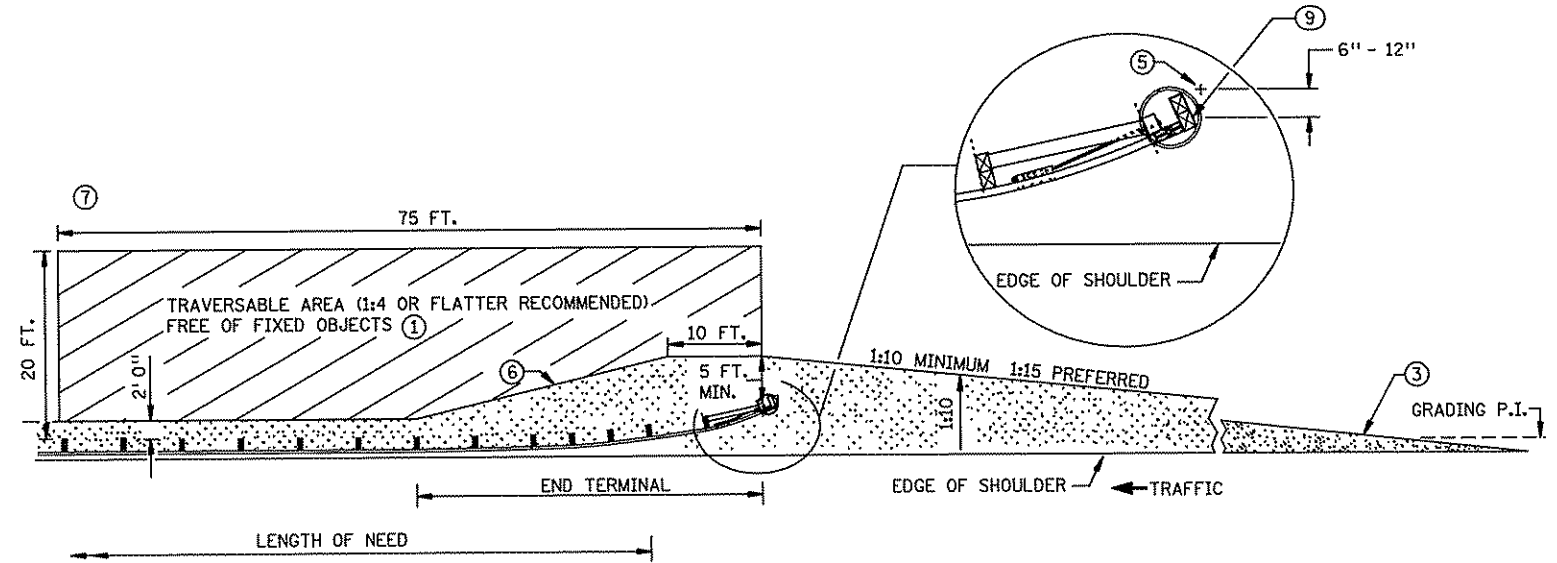

PLAN VIEW ④ ⑧  
(ELT)

NOTES:

- ALL CROSS SLOPES ARE IN FOOT/FOOT UNLESS OTHERWISE NOTED.
- ALL GUARDRAIL POSTS SHALL BE 6 FT. 3 IN. CENTER TO CENTER (DESIGN B), EXCEPT WHERE NOTED.
- CHANGES (TO SUBJECTS COVERED BY THIS SHEET) INDICATED IN THE PLANS OR ON PLATES WITH MORE RECENT APPROVAL DATES SHALL APPLY.
- GRADING AND DRAINAGE HARDWARE ARE NOT INCIDENTAL TO GUARDRAIL INSTALLATION.
- ① SLOPES BETWEEN 1:3 AND 1:4 PERMITTED WHEN 1:4 OR FLATTER IS NOT POSSIBLE. FOR SLOPES STEEPER THAN 1:3 THE AREA IMMEDIATELY BEHIND AND BEYOND THE END TERMINAL SHOULD, AT LEAST, BE SIMILAR IN CROSS SECTION TO THE UNSHIELDED ROADSIDE AREA UPSTREAM OF THE END TERMINAL.
- ② THE LAST 50 FT. OF TANGENT TERMINALS CAN BE FLARED AT 1:50 TAPER.
- ③ WHEN GRADING PLATFORMS ARE BUILT, THEY MUST BE SMOOTHLY TRANSITIONED TO EXISTING SIDE SLOPE SO THE ENTIRE ROADSIDE APPROACH TO THE BARRIER REMAINS TRAVERSABLE, AS WELL AS THE AREA IMMEDIATELY BEHIND IT.

- ④ SEE STANDARD PLATE 8329.
- ⑤ SNOWPLOW MARKER (X4-5) WITH A 2 LB./FT. DELINEATOR POST 8 FT. LONG (SPEC. 3401) DRIVEN INTO THE GROUND. EXTEND 3 FT. ABOVE TERMINAL. THE MARKER IS INCIDENTAL FOR WHICH NO DIRECT PAYMENT WILL BE MADE. MARK BOTH THE BEGINNING AND END OF PLATE BEAM GUARDRAIL INSTALLATION.
- ⑥ 1:10 OR FLATTER SLOPE P.I..
- ⑦ GRADUALLY BLEND SLOPE FROM TRAVERSABLE AREA TO STEEP EXISTING SLOPE (WHEN SLOPE IS STEEPER THAN 1:6).
- ⑧ IF THE TERRAIN BEYOND THE TERMINAL END AND IMMEDIATELY BEHIND THE BARRIER IS NOT SAFELY TRAVERSABLE, A TANGENT (ENERGY- ABSORBING) TERMINAL SHALL BE USED.

- ⑨ MARK THE APPROACH END OF PLATE BEAM GUARDRAIL INSTALLATIONS WITH A STRIPED OBJECT MARKER SIZED TO FIT THE END TERMINAL, HAVING ALTERNATING BLACK AND REFLECTIVE YELLOW (WIDE ANGLE PRISMATIC RETROREFLECTIVE SHEETING). STRIPES SHALL SLOPE DOWNWARD AT A 45 DEGREE ANGLE TOWARD THE SIDE ON WHICH TRAFFIC PASSES. FOR FLAT END TREATMENTS THE OBJECT MARKER SHALL FIT INSIDE THE RECESSED AREA. FOR ROUNDED END TREATMENTS THE OBJECT MARKER SHALL WRAP AROUND THE CIRCULAR END AND BE MOUNTED SO THE TOP OF THE OBJECT MARKER LINES UP WITH THE TOP OF THE END TREATMENT.

STANDARD SHEET NO. 5-297.601 (3 OF 3)	TITLE: GUARDRAIL INSTALLATIONS AT MEDIANS & END TREATMENTS (FOR NEW CONSTRUCTION AND RETROFITS WITHOUT SITE RESTRICTIONS)
STANDARD APPROVED: AUGUST 17, 2005	
STATE AID PROJECT NO. 02-614-37 SHEET NO. 19 OF 51 SHEETS	



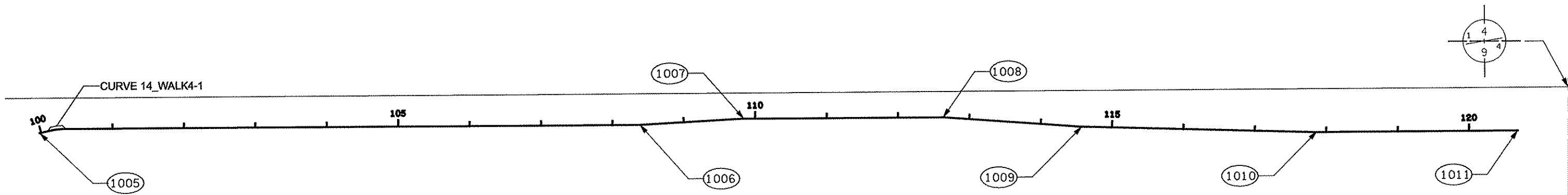

ALIGNMENT TABULATION										
POINT NUMBER	POINT	ALIGNMENT	CIRCULAR CURVE DATA					COORDINATES		AZIMUTH
			DELTA	DEGREE	RADIUS	TANGENT	LENGTH	E	N	
LEFT EDGE OF PROPOSE WALK ALIGNMENT <14_WALK4>										
		☉ C.S.A.H. 14								
1005	POT	100+00.000						474,302.4948	159,116.9175	
	PC	100+10.022						474,312.2176	159,119.3487	N 75° 57' 40.26" E
14_WALK4-1	PI	100+22.268	13° 57' 49.14" RT	57° 17' 44.81"	100.000'	12.246'	24.371'	474,324.0981	159,122.3194	PI
	CC							474,336.4756	159,022.3356	
	PT	100+34.393						474,336.3444	159,122.3355	N 89° 55' 29.40" E
1006	POT	108+38.363						475,140.3131	159,123.3902	
1007	POT	109+84.409						475,286.1367	159,131.4567	
1008	POT	112+63.448						475,565.1753	159,131.6898	
1009	POT	114+57.664						475,758.8673	159,117.4368	
1010	POT	117+84.452						476,085.5188	159,107.9704	
1011	POT	120+59.164						476,360.2288	159,108.8949	

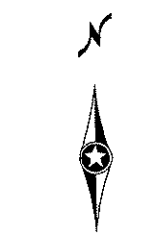
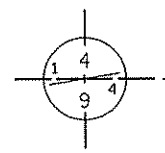

1 OF 1

NO	DATE	BY	CKD	APPR	REVISION

NAME: p:\14\_ped\plan14\_PED\_AL3.dgn 12/01/2010 2:14:58 PM

I HEREBY CERTIFY THAT THIS PLAN WAS PREPARED BY ME OR UNDER MY DIRECT SUPERVISION AND THAT I AM A DULY LICENSED PROFESSIONAL ENGINEER UNDER THE LAWS OF THE STATE OF MINNESOTA.

PRINT NAME: CURT A. KOBILARCSIK  
 SIGNATURE: *Curt Kobilarcsik*  
 DATE: 12-9-10 LICENSE NO. 24756

DRAWN BY: NJD DATE: 8-20-10  
 DESIGN BY: NJD DATE: 5-28-10  
 CHECKED BY: JEO DATE: 11-29-10

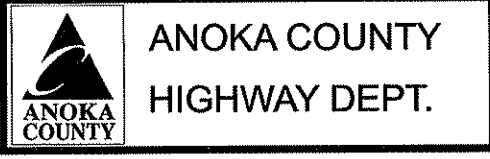

STATE AID PROJECT NO. 02-614-37  
 COON RAPIDS CITY NO. 06-48  
 MN STATE PROJECT NO. 114-020-40

ALIGNMENT TAB  
 Sheet 20 of 51 Sheets

CONSTRUCTION NOTES:

- (A) 5' CONCRETE WALK
- (B) B412 CURB & GUTTER
- (C) INPLACE J BARRIER
- (D) SPECIAL FENCE SEE BRIDGE PLAN
- (E) PROPOSED J BARRIER SEE BRIDGE PLAN
- (F) CHAIN LINK FENCE PAID FOR AS WIRE FENCE DESIGN 60V-9322
- (H) INPLACE HAND HOLE
- ☆ INPLACE LIGHT POLE
- (I) CONCRETE WALK SPECIAL

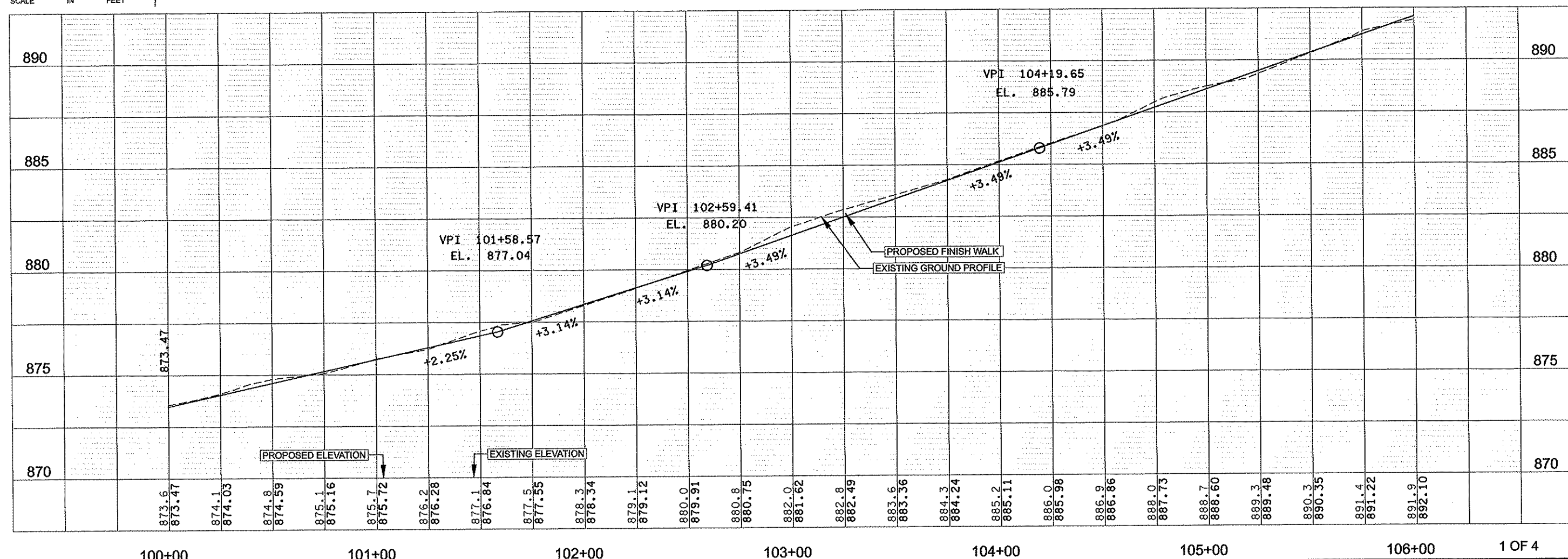
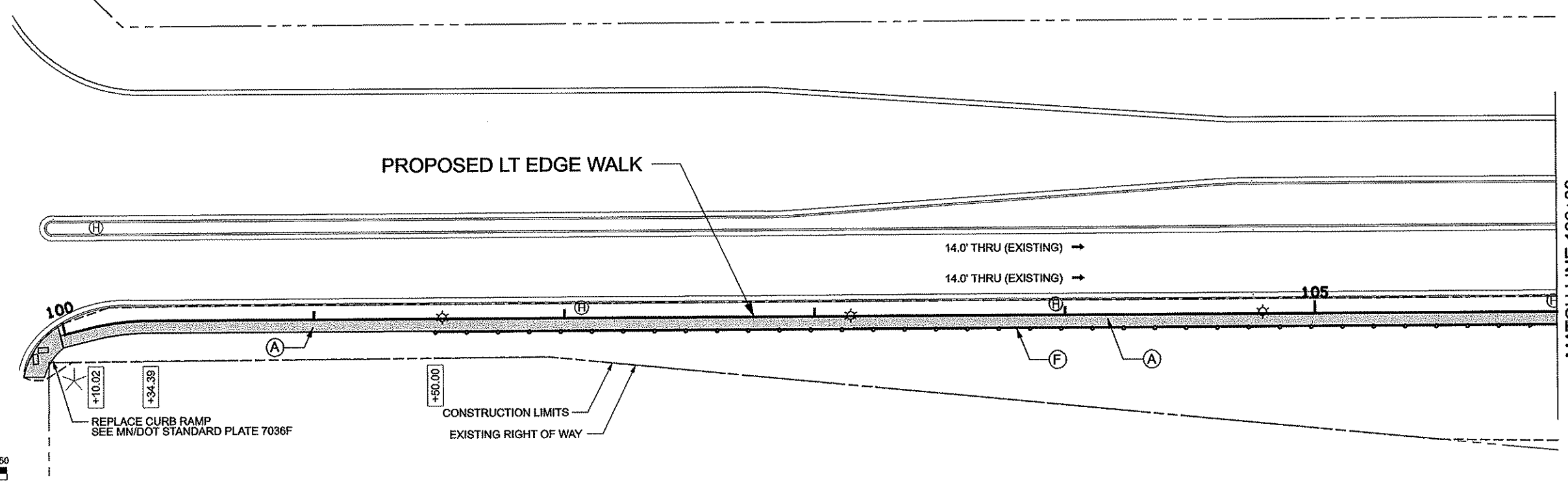

<p>NO. DATE BY CKD APPR</p> <p>REVISION 12/01/2010 2:15:02 PM</p> <p>NAME: p114_pedplan14_PED_PP1-P1.dgn</p>	<p>I HEREBY CERTIFY THAT THIS PLAN WAS PREPARED BY ME OR UNDER MY DIRECT SUPERVISION AND THAT I AM A DULY LICENSED PROFESSIONAL ENGINEER UNDER THE LAWS OF THE STATE OF MINNESOTA.</p> <p>PRINT NAME: CURT A. KOBILARCSIK</p> <p>SIGNATURE: <i>Curt Kobilarcsik</i></p> <p>DATE: 12-9-10 LICENSE NO. 24756</p>	<p>DRAWN BY: NJD DATE: 8-20-10</p> <p>DESIGN BY: NJD DATE: 5-26-10</p> <p>CHECKED BY: JEO DATE: 11-29-10</p>	<p><b>ANOKA COUNTY</b> <b>HIGHWAY DEPT.</b></p>	<p>STATE AID PROJECT NO. 02-614-37</p> <p>COON RAPIDS CITY NO. 06-48</p> <p>MN STATE PROJECT NO. 114-020-40</p>	<p>PLAN PROFILE</p> <p>STA 100+00.00 TO 106+00.00</p> <p>Sheet 21 of 51 Sheets</p>
--	--	--	---	---	--

**CONSTRUCTION NOTES:**

- (A) 5' CONCRETE WALK
- (B) B412 CURB & GUTTER
- (C) INPLACE J BARRIER
- (D) SPECIAL FENCE SEE BRIDGE PLAN
- (E) PROPOSED J BARRIER SEE BRIDGE PLAN
- (F) CHAIN LINK FENCE PAID FOR AS WIRE FENCE DESIGN 60V-9322
- (H) INPLACE HAND HOLE
- ☆ INPLACE LIGHT POLE
- (I) CONCRETE WALK SPECIAL

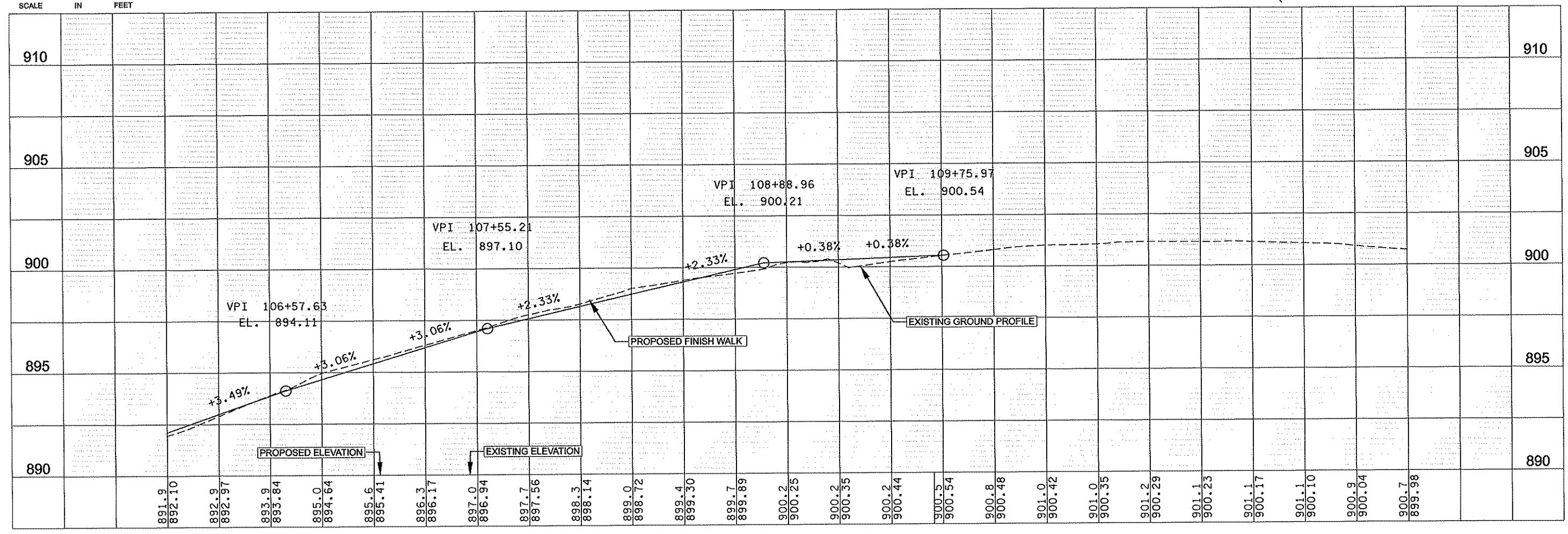
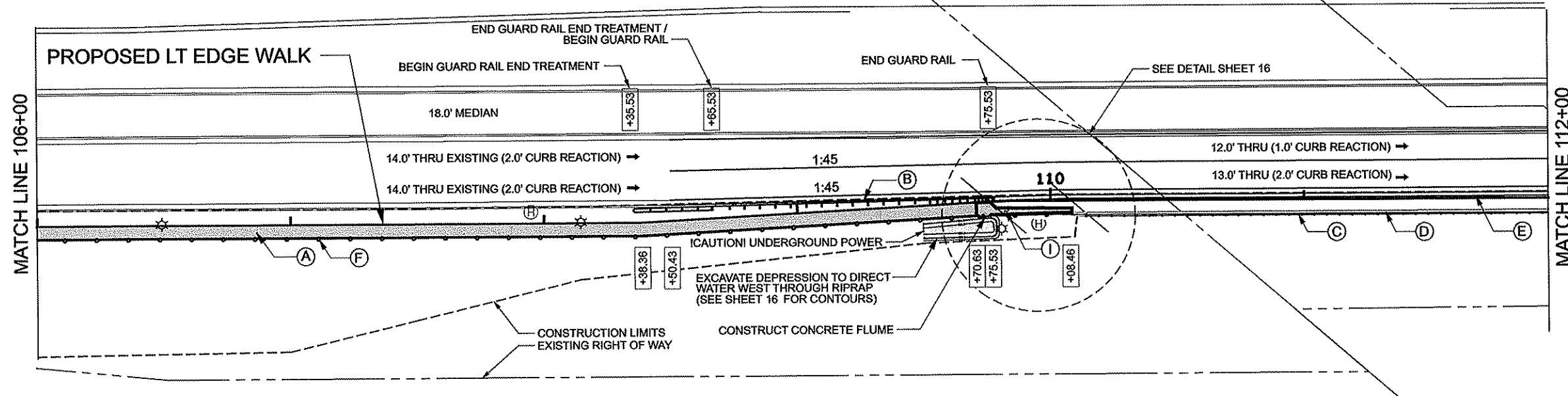

106+00                      107+00                      108+00                      109+00                      110+00                      111+00                      112+00                      2 OF 4

NO	DATE	BY	CKD	APPR	REVISION
NAME: p114_pedplan14_PED_PP2-P2.dgn					
2:16:05 PM					

I HEREBY CERTIFY THAT THIS PLAN WAS PREPARED BY ME OR UNDER MY DIRECT SUPERVISION AND THAT I AM A DULY LICENSED PROFESSIONAL ENGINEER UNDER THE LAWS OF THE STATE OF MINNESOTA.  
 PRINT NAME: CURT A. KOBILARCSIK  
 SIGNATURE: *Curt Kobilarcsik*  
 DATE: 12-9-10                      LICENSE NO. 24756

DRAWN BY: NJD                      DATE: 8-20-10  
 DESIGN BY: NJD                      DATE: 6-28-10  
 CHECKED BY: JEO                      DATE: 11-29-10

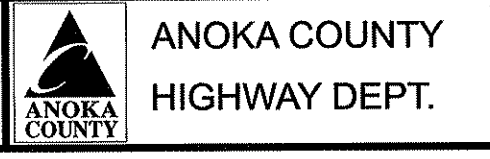

STATE AID PROJECT NO. 02-614-37  
 COON RAPIDS CITY NO. 06-48  
 MN STATE PROJECT NO. 114-020-40

PLAN PROFILE  
 STA 106+00.00 TO 112+00.00  
 Sheet 22 of 51 Sheets

CONSTRUCTION NOTES:

- (A) 5' CONCRETE WALK
- (B) B412 CURB & GUTTER
- (C) INPLACE J BARRIER
- (D) SPECIAL FENCE SEE BRIDGE PLAN
- (E) PROPOSED J BARRIER SEE BRIDGE PLAN
- (F) CHAIN LINK FENCE PAID FOR AS WIRE FENCE DESIGN 60V-9322
- (H) INPLACE HAND HOLE
- ☆ INPLACE LIGHT POLE
- (I) CONCRETE WALK SPECIAL

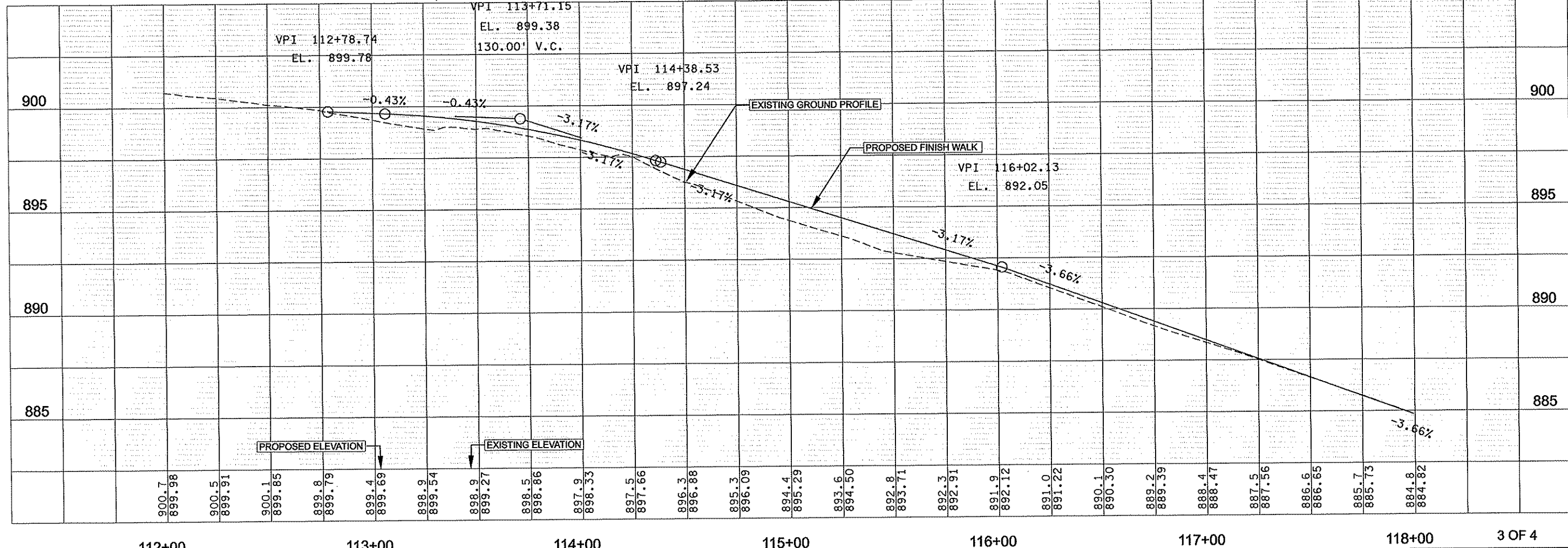
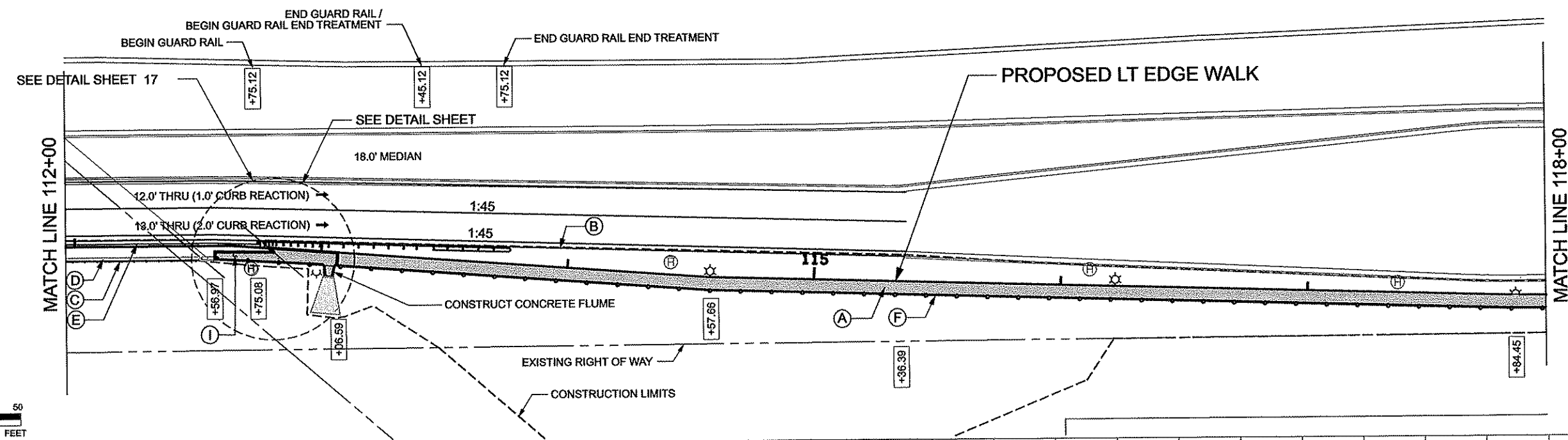

NO	DATE	BY	CHKD	APPR	REVISION

I HEREBY CERTIFY THAT THIS PLAN WAS PREPARED BY ME OR UNDER MY DIRECT SUPERVISION AND THAT I AM A DULY LICENSED PROFESSIONAL ENGINEER UNDER THE LAWS OF THE STATE OF MINNESOTA.  
 PRINT NAME: CURT A. KOBILARCSIK  
 SIGNATURE: *Curt Kobilarcsik*  
 DATE: 12-9-10 LICENSE NO. 24758

DRAWN BY: NJD DATE: 8-20-10  
 DESIGN BY: NJD DATE: 6-28-10  
 CHECKED BY: JEO DATE: 11-29-10



STATE AID PROJECT NO. 02-614-37  
 COON RAPIDS CITY NO. 06-48  
 MN STATE PROJECT NO. 114-020-40

PLAN PROFILE  
 STA 112+00.00 TO 118+00.00  
 Sheet 23 of 51 Sheets

**CONSTRUCTION NOTES:**

- (A) 5' CONCRETE WALK
- (B) B412 CURB & GUTTER
- (C) INPLACE J BARRIER
- (D) SPECIAL FENCE SEE BRIDGE PLAN
- (E) PROPOSED J BARRIER SEE BRIDGE PLAN
- (F) CHAIN LINK FENCE PAID FOR AS WIRE FENCE DESIGN 60V-9322
- (H) INPLACE HAND HOLE
- ☆ INPLACE LIGHT POLE
- (I) CONCRETE WALK SPECIAL

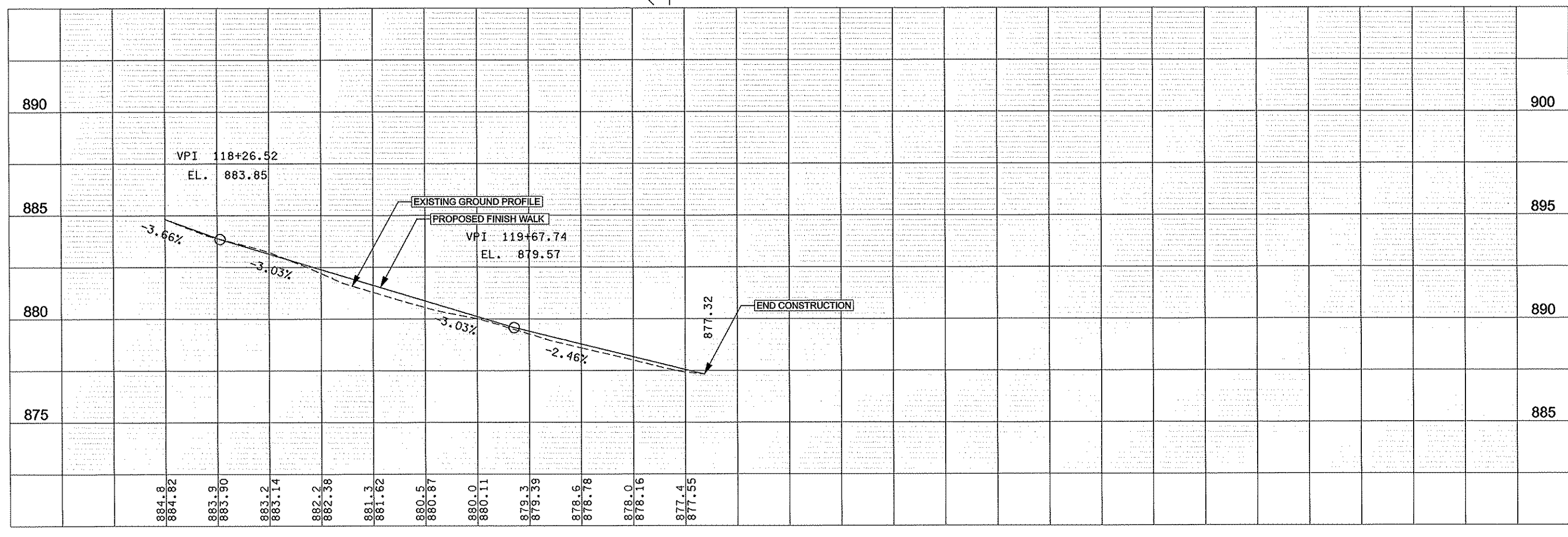
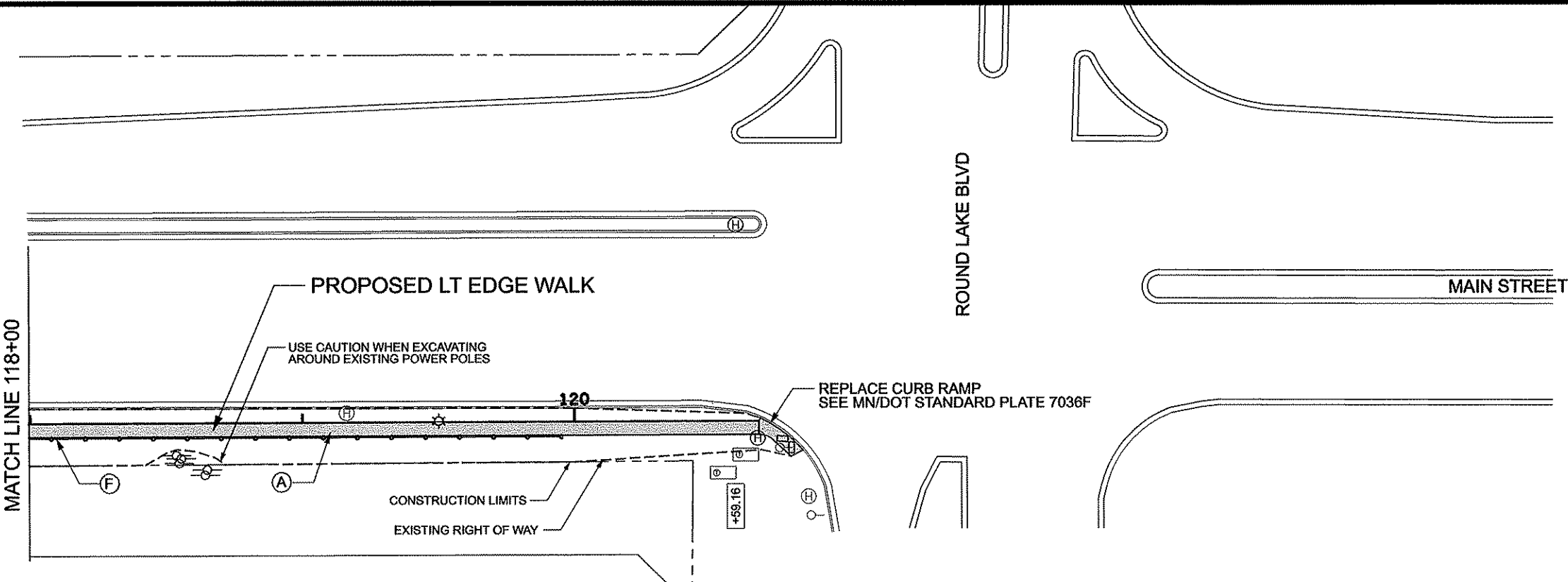

NO	DATE	BY	CKD	APPR	REVISION		
NAME: p114_pedplan14_PED_PP4-P3.dgn						12/01/2010	2:15:13 PM

I HEREBY CERTIFY THAT THIS PLAN WAS PREPARED BY ME OR UNDER MY DIRECT SUPERVISION AND THAT I AM A DULY LICENSED PROFESSIONAL ENGINEER UNDER THE LAWS OF THE STATE OF MINNESOTA.

PRINT NAME: CURT A. KOBILARCSIK  
 SIGNATURE: *Curt Kobilarcsik*  
 DATE: 12-9-10 LICENSE NO. 24756

DRAWN BY: NJD DATE: 8-20-10  
 DESIGN BY: NJD DATE: 5-28-10  
 CHECKED BY: JEO DATE: 11-29-10

**ANOKA COUNTY  
HIGHWAY DEPT.**

STATE AID PROJECT NO. 02-614-37  
 COON RAPIDS CITY NO. 06-48  
 MN STATE PROJECT NO. 114-020-40

**PLAN PROFILE**

STA 118+00.00 TO 120+59.14

Sheet 24 of 51 Sheets



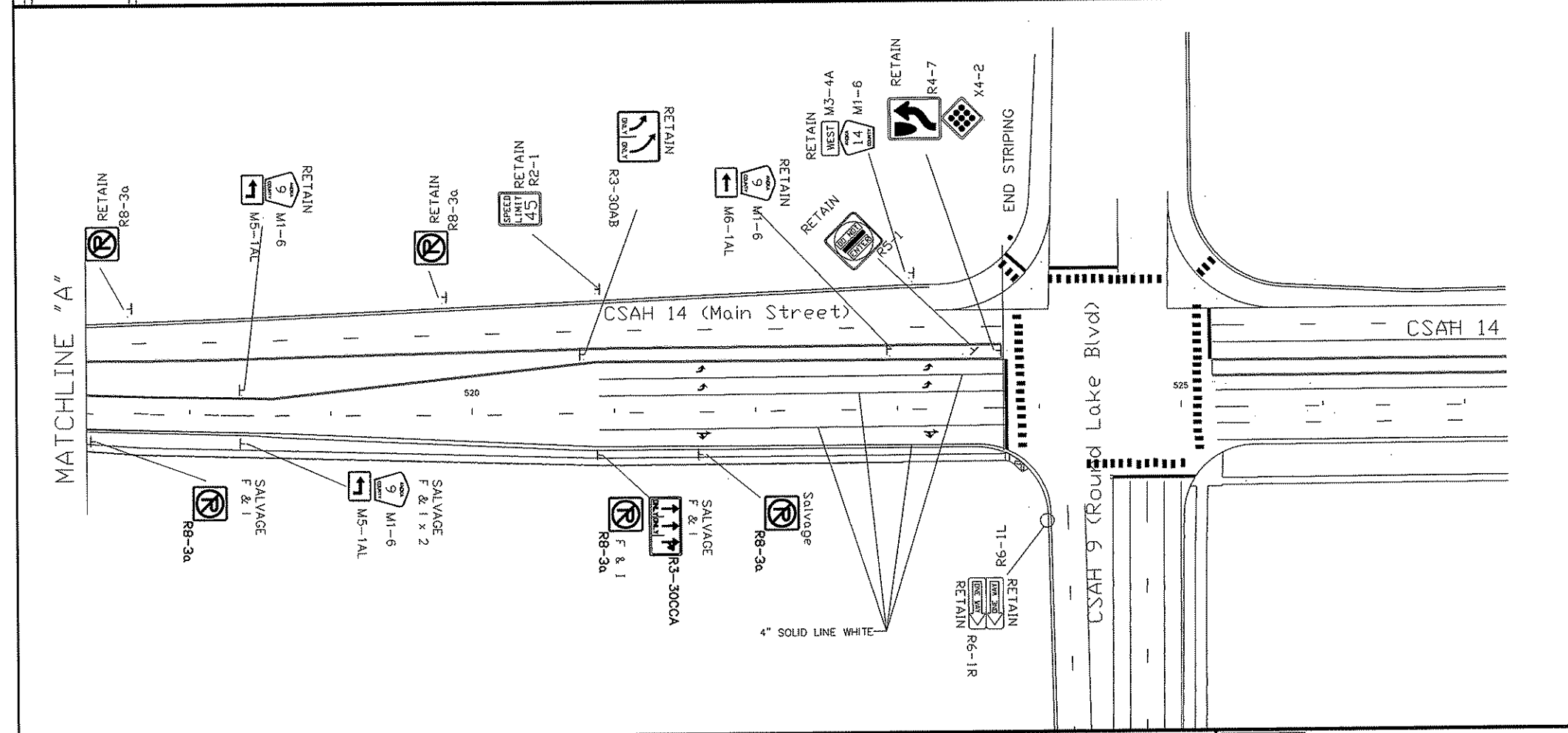
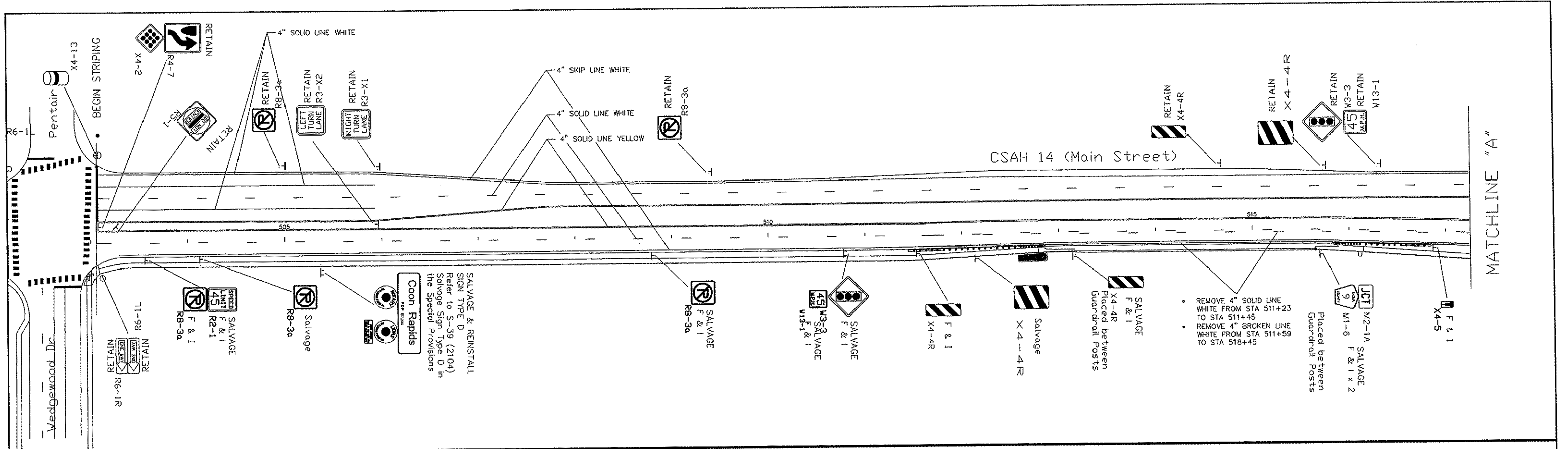

- Notes:
1. ALL TRAFFIC CONTROL DEVICES SHALL CONFORM TO THE MOST RECENT EDITION OF THE MINNESOTA MANUAL ON UNIFORM TRAFFIC CONTROL DEVICES INCLUDING THE FIELD MANUAL DATED JANUARY, 2007.
  2. LOCATION OF ALL PERMANENT STRIPING AND PAVEMENT MESSAGES ARE APPROXIMATE. EXACT LOCATIONS SHALL BE DETERMINED IN THE FIELD BY THE ENGINEER.
  3. ALL MAINLINE PERMANENT STRIPING AND PAVEMENT MESSAGES SHALL BE PLACED WITHIN 72 HOURS OF MAINLINE PAVING.
  4. SEE PERMANENT SIGN TABULATIONS FOR ADDITIONAL INFORMATION.
  5. ALL SEGMENT STRIPE LINES SHALL BE EPOXY.
  6. ONLY THOSE SIGNS MARKED "SALVAGE" SHALL BE SALVAGED. ALL OTHER SIGNS SHALL REMAIN IN PLACE.

8/24/2010	MTH		Edits
NO	DATE	BY	CKD APPR
			REVISION

NAME: PA14\_PED\Bases\TRAFFIC\14\_Ped\_SS.dwg

I HEREBY CERTIFY THAT THIS PLAN WAS PREPARED BY ME OR UNDER MY DIRECT SUPERVISION AND THAT I AM A DULY LICENSED PROFESSIONAL ENGINEER UNDER THE LAWS OF THE STATE OF MINNESOTA.

PRINT NAME: **CHAD KOBIARCSIK**

SIGNATURE: *Chad Kobiarsik*

DATE: **12-9-10** LICENSE NO. **24756**

DRAWN BY: MTH DATE: 05/27/10

DESIGN BY: MTH DATE: 05/27/10

CHECKED BY: JR DATE: 08/24/10



**ANOKA COUNTY**  
**HIGHWAY DEPT.**

STATE AID PROJECT NO. 02-614-37

COON RAPIDS PROJECT NO. 06-48

MN STATE PROJECT NO. 114-20-40

Signing & Striping Plan  
CSAH 14 Ped Crossing

Sheet 25 of 51 Sheets

SALVAGE SIGN PANELS TYPE C				C
SIGN DESIGNATION	SIGN SIZE	Sign Salvage	Notes	
R2-1	24" x 30"	1		
R8-3a	24" x 24"	1		
R8-3a	24" x 24"	1		
W3-3	48" x 48"	1		
W13-1	24" x 24"	1	A	
X4-4R	18" x 18"	1		
X4-4R	18" x 36"	1		
M2-1A	21" x 15"	1	B	
M1-6A	24" x 24"	1		
R8-3a	24" x 24"	1		
M1-6A	24" x 24"	1		
M5-1AL	15" x 21"	1	C	
R3-30CCA	54" x 30"	1		
R8-3a	24" x 24"	1		
<b>Project Totals</b>		<b>14</b>		

NOTES: This table includes Salvage Type "C" signs only

A) Sign mounted below W3-3 sign post assembly

B) Sign mounted above M1-6A sign post assembly

C) Sign mounted below M1-6A sign post assembly

SIGN PANEL TYPE C									
M. U. T. C. D. CODE	SIZE	PANEL AREA FT. <sup>2</sup>	INSERT	QUANTITY	TOTAL PANEL AREA FT. <sup>2</sup>	No. POST	MOUNTING HEIGHT (TO MOUNTING EDGE) FT. (±)	I	
R2-1	24" x 30"	5.00		1	5.00	1	7.0'		
R3-30CCA	54" x 30"	11.25		1	11.25	2	7.0'		
R8-3a	24" x 24"	4.00		4	16.00	1	7.0'		
W3-3	36" x 36"	9.00		1	9.00	2	7.0'		
W13-1	24" x 24"	4.00		1	4.00		5.0'		
M1-6a	24" x 24"	4.00		2	8.00	1	7.0'		
M2-1A	21" x 15"	2.19		1	2.19		7.0'		
M5-1AL	21" x 15"	2.19		1	2.19		7.0'		
X4-4R	18" x 18"	2.25		1	2.25	1	7.0'		
X4-4R	18" x 36"	4.50		1	4.50	1	7.0'		
X4-5	6" x 12"	0.50		1	0.50	1	7.0'		
					64.88				

STRIPING TAB					J
	REMOVE PAVEMENT MARKING PERMANENT LIN FT	SOLID LINE		BROKEN LINE	
		4" WHITE (LF)	4" YELLOW (LF)	4" WHITE (4) (LF)	
Eastbound CSAH 14	778	2881	2073	420	
Westbound CSAH 14		2596	2070	420	
<b>PROJECT TOTAL</b>	<b>778</b>	<b>5477</b>	<b>4143</b>	<b>840</b>	

NOTES:

- ALL STRIPING SHALL BE EPOXY UNLESS OTHERWISE NOTED
- SEE TEMPORARY PAVEMENT MARKINGS FOR ALL MARKINGS RELATED TO STAGING
- BROKEN LINES SHALL BE 10' SOLID WITH A 40' GAP

GENERAL NOTES:

- ALL TRAFFIC CONTROL DEVICES SHALL CONFORM AND BE PLACED IN ACCORDANCE TO THE "MINNESOTA MANUAL ON UNIFORM TRAFFIC CONTROL DEVICES" (MN MUTCD), AND PART VI, "FIELD MANUAL FOR TEMPORARY TRAFFIC CONTROL ZONE LAYOUTS".
- POST LENGTHS ARE APPROXIMATE AND INCLUDE EMBEDMENT, BUT DO NOT INCLUDE ADDITIONAL LENGTH REQUIRED FOR SPLICE.
- SEE SHEETS 28-29 FOR STRUCTURAL DETAILS.
- SEE STANDARD SIGNS MANUAL FOR PUNCHING CODE AND DETAILED DRAWINGS OF TYPE C SIGN PANELS.

SPECIFIC NOTES:

- MOUNTING HEIGHT IS MINIMUM
- W13-1 MOUNTED BELOW W3-3 SIGN ASSEMBLY
- M2-1A MOUNTED ABOVE M1-6A SIGN ASSEMBLY
- M5-1AL MOUNTED BELOW M1-6A SIGN ASSEMBLY
- SEE SHEET 27-29 FOR TYPICAL MOUNTING

NO	DATE	BY	CKD	APPR	REVISION
	8/24/2010	MTH			Edits

I HEREBY CERTIFY THAT THIS PLAN WAS PREPARED BY ME OR UNDER MY DIRECT SUPERVISION AND THAT I AM A DULY LICENSED PROFESSIONAL ENGINEER UNDER THE LAWS OF THE STATE OF MINNESOTA.  
 PRINT NAME: **CURT KOBILARCIK**  
 SIGNATURE: *Curt Kobilarsik*  
 DATE: **12-9-10** LICENSE NO. **24756**

DRAWN BY: MTH DATE: 05/27/10  
 DESIGN BY: MTH DATE: 05/27/10  
 CHECKED BY: JR DATE: 08/24/10



ANOKA COUNTY  
HIGHWAY DEPT.

STATE AID PROJECT NO. 02-614-37  
 COON RAPIDS PROJECT NO. 06-48  
 MN STATE PROJECT NO. 114-20-40

Signing & Striping  
Quantities

Sheet 26 of 51 Sheets

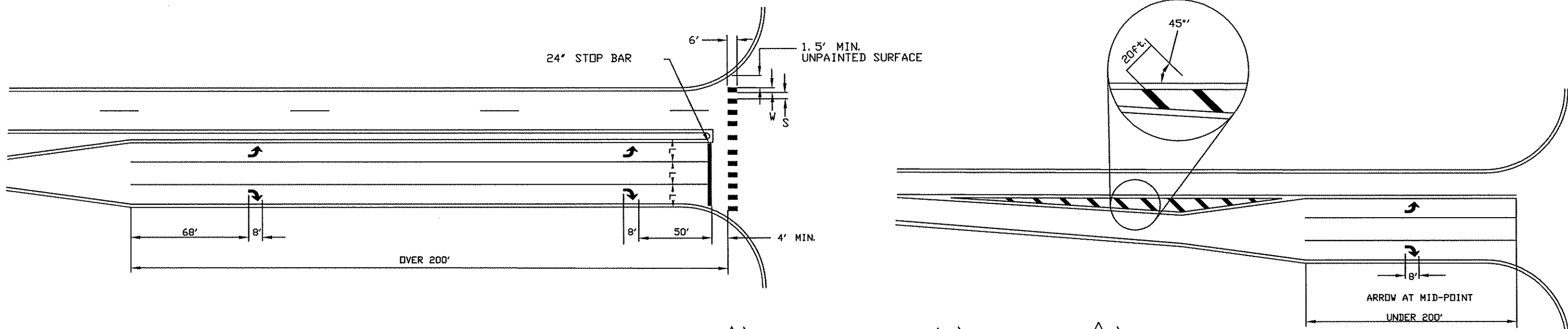

( L )	( W )	( S )
WIDTH OF INSIDE LANE	WIDTH OF PAINTED AREAS	WIDTH OF SPACE
9'	2.0'	2.5'
10'	2.5'	2.5'
11'	2.5'	3.0'
12'	3.0'	3.0'
13'	3.0'	3.5'

- NOTES: CROSSWALKS:
- 1.) PAINTED AREAS ARE TO BE CENTERED ON CENTER AND LANE LINES, EVEN IF INTERSECTION IS NOT ALIGNED.
  - 2.) LOCATION OF ZEBRA CROSSWALKS AND STOP BARS, SIGNAL LOOPS AND PED RAMPS ARE APPROXIMATE. FINAL LOCATIONS ARE TO BE DETERMINED AND FIELD VERIFIED DURING CONSTRUCTION BY THE FIELD ENGR.
  - 3.) ZEBRA CROSSWALKS ARE TO BE PARALLEL TO THE DRIVING LANE OR LANES, EVEN IF THE STREET IS ON AN ANGLE TO THE INTERSECTION.
  - 4.) A MIN. OF 1.5' CLEAR DISTANCE MUST BE LEFT ADJACENT TO THE CURB. IF LAST PAINTED AREA FALLS INTO THIS AREA, IT MUST BE OMITTED.
  - 5.) ON TWO LANE STREETS, USE SPACING SHOWN FOR AN 11' INSIDE LANE.

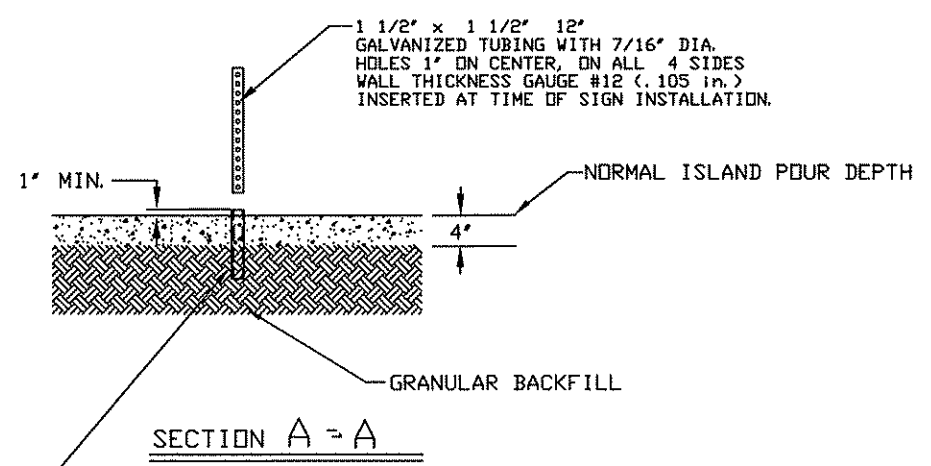
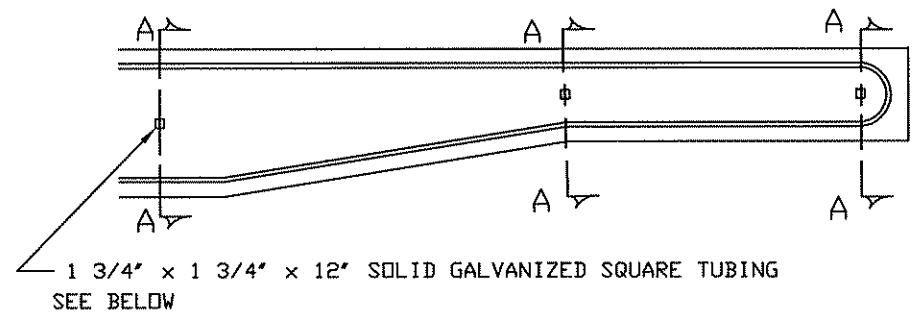

INSTALL 1 3/4" x 1 3/4" x 12" SOLID WALL GALVANIZED SQUARE TUBING BEFORE CONCRETE POUR. HAMMER INTO GROUND SO THAT 1" OF TUBE IS ABOVE GROUND. RE-PLUMB AT TIME OF POUR.

GROUND POST MOUNT SIGN INSTALLATION TYPICAL - URBAN

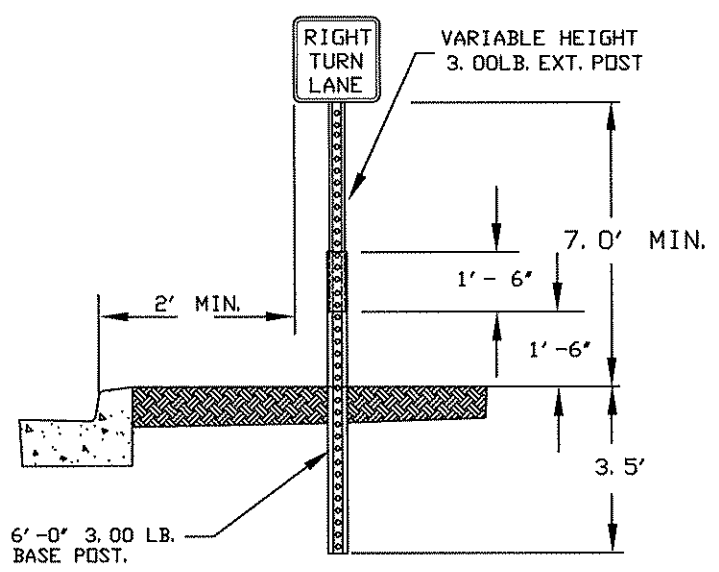

ISLAND MOUNT BREAK-AWAY SIGN INSTALLATION TYPICAL

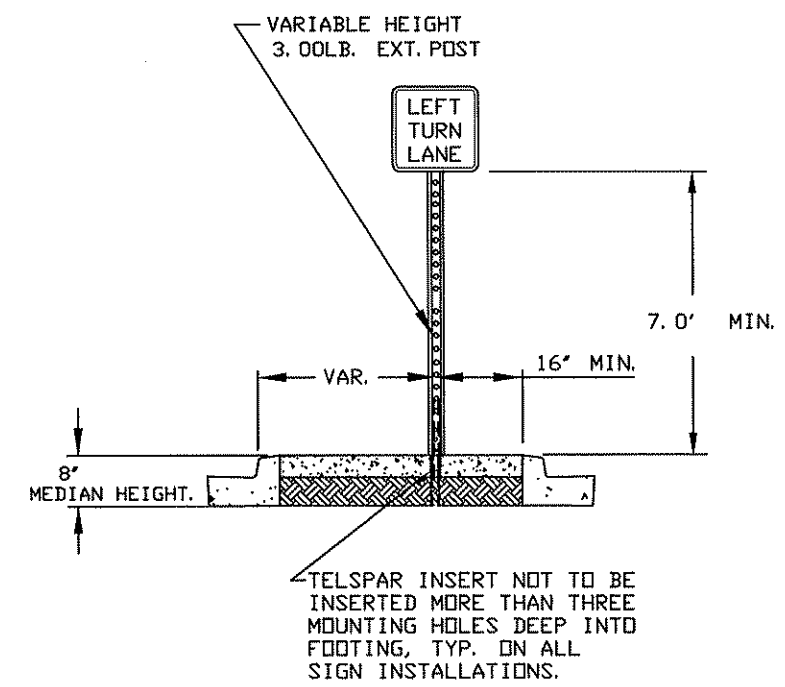

TELSPAR INSERT NOT TO BE INSERTED MORE THAN THREE MOUNTING HOLES DEEP INTO FOOTING, TYP. ON ALL SIGN INSTALLATIONS.

TYPE C & D POST

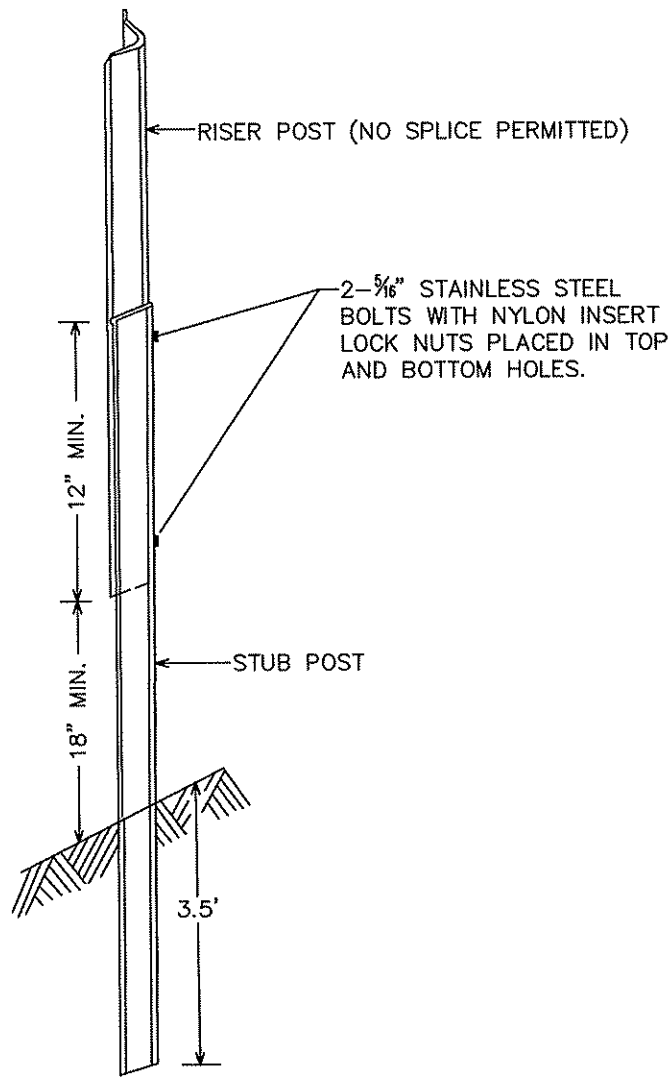

U POST SPLICE

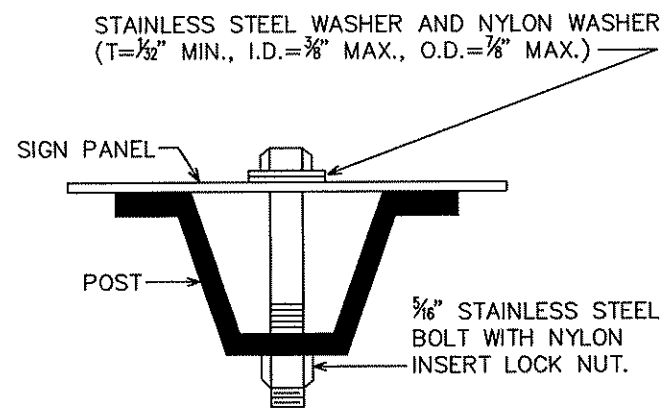

U POST MOUNTING  
TYPE C SIGNS

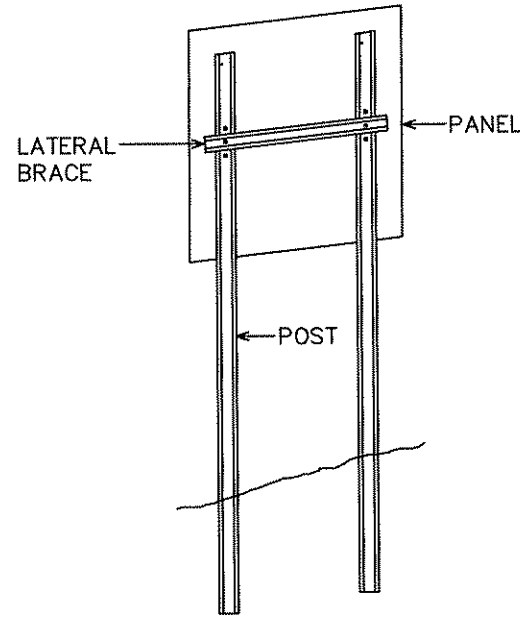

TYPICAL TYPE C INSTALLATION

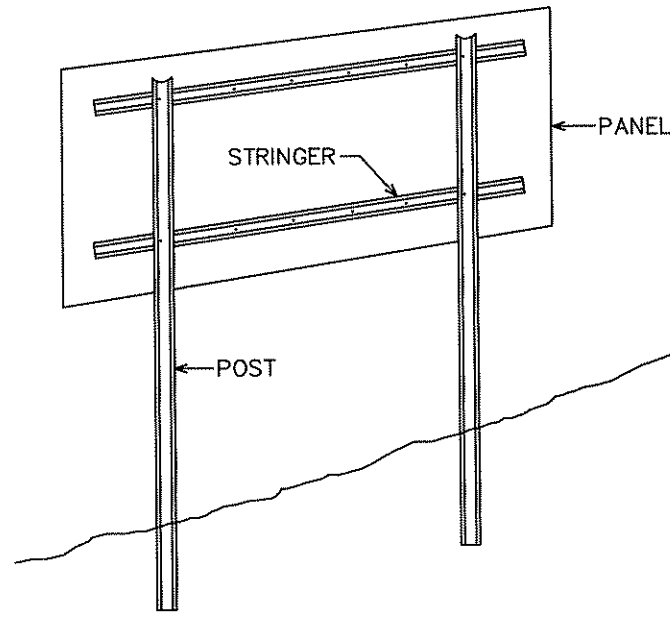

TYPICAL TYPE D INSTALLATION

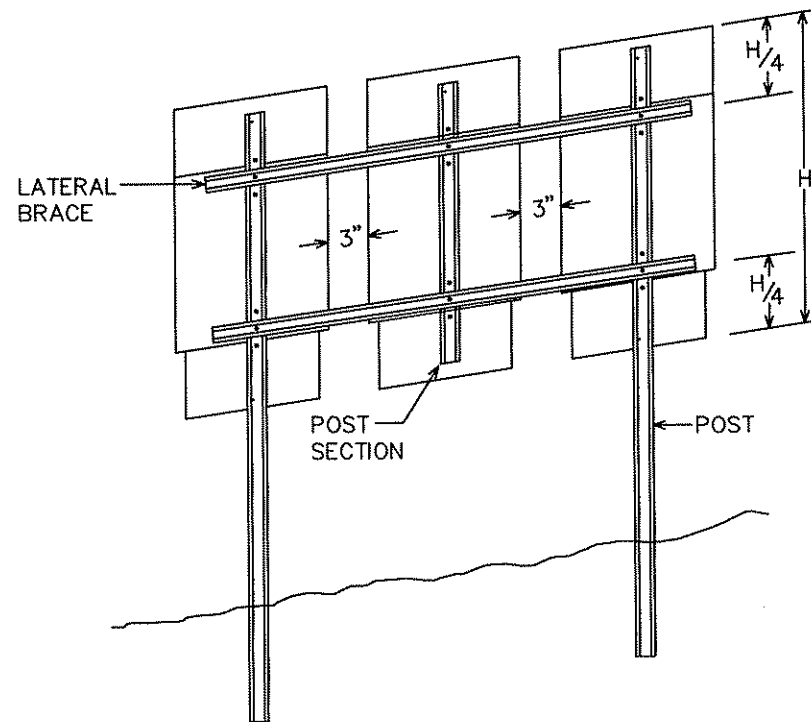

MODIFIED TYPE C INSTALLATION

NOTES:

1. USE 3 LB/FT STUB POSTS, RISER POSTS, STRINGERS, KNEE BRACES, LATERAL BRACES AND KNEE BRACE STUB POSTS. ALL SHALL CONFORM TO MN 3401.
2. FOR TYPE D SIGN POSTS LENGTHS AND SPACINGS, SEE SIGN DATA SHEET
3. TYPE D SIGN PANELS SHALL BE BOLTED TO STRINGERS AT 24" MAXIMUM INTERVALS IN ACCORDANCE WITH THE TYPE D STRINGER AND PANEL-JOINT ((SEE STANDARD SIGNS MANUAL).
4. MOUNTING (PUNCH CODE) FOR THE TYPE C SIGN PANELS SHALL BE AS INDICATED IN THE STANDARD SIGNS MANUAL UNLESS OTHERWISE SPECIFIED.
5. ALL RISER (VERTICAL) U POSTS SHALL BE SPLICED. DRIVEN STUB POSTS SHALL BE AT LEAST 7' LONG.
6. USE GRADE 5 ZINC PLATED 5/16" BOLTS, WASHERS AND NYLON INSERT LOCK NUTS AS SHOWN FOR ALL GROUND MOUNTED AND OVERHEAD MOUNTED SIGNS.
7. ZINC PLATED WASHER WITH SAME DIMENSIONS SHALL BE PROVIDED BETWEEN ALL NYLON WASHERS AND BOLT HEADS.
8. BRACING STUBS SHALL BE NO MORE THAN 4" ABOVE GROUND AND EMBEDDED AT LEAST 3'.
9. A-FRAME BRACKET SHALL BE STEEL CONFORMING TO MN/DOT 3306 AND GALVANIZED IN ACCORDANCE WITH MN/DOT 3394.
10. COLLARS SHALL BE USED TO SHIM OVERLAYS AND DEMOUNTABLE LEGEND AWAY FROM PANEL WHERE INTERFERENCE WITH BOLT HEADS IS ENCOUNTERED. MN/DOT 3352.2AF.
11. 2 POST TYPE C SIGNS SHALL BE REINFORCED WITH AT LEAST ONE LATERAL BRACE. INSTALLATIONS WHERE THE TOTAL PANEL HEIGHT IS 60" OR MORE SHALL HAVE TWO LATERAL BRACES LOCATED APPROXIMATELY AT THE QUARTER POINTS.
12. WHERE 2 SINGLE POST TYPE C SIGNS ARE INSTALLED SIDE BY SIDE, THEY SHALL BE REINFORCED LATERALLY BY AT LEAST 2 BRACES, BOLTED AT EACH POST AND LOCATED APPROXIMATELY AT THE QUARTER POINTS.
13. WHERE 3 OR MORE TYPE C SIGNS ARE INSTALLED SIDE BY SIDE, THEY SHALL BE REINFORCED LATERALLY BY AT LEAST 2 BRACES, BOLTED AT EACH POST AND POST SECTION AND LOCATED APPROXIMATELY AT THE QUARTER POINTS AS SHOWN IN MODIFIED TYPE C INSTALLATION.

TYPE C & D SIGN  
STRUCTURAL DETAILS

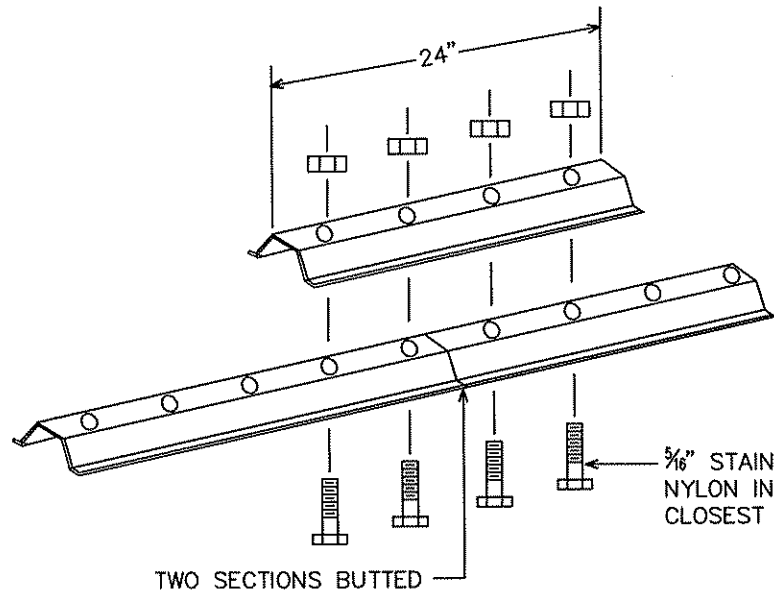

LATERAL BRACE OR STRINGER  
SPlice DETAIL (EXPLODED VIEW)

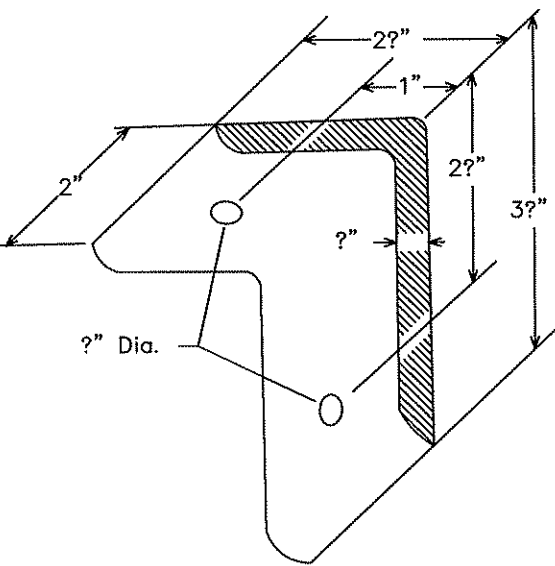

A-FRAME BRACKET

(STEEL MN/DOT 3306 GALVANIZED PER MN/DOT 3394)

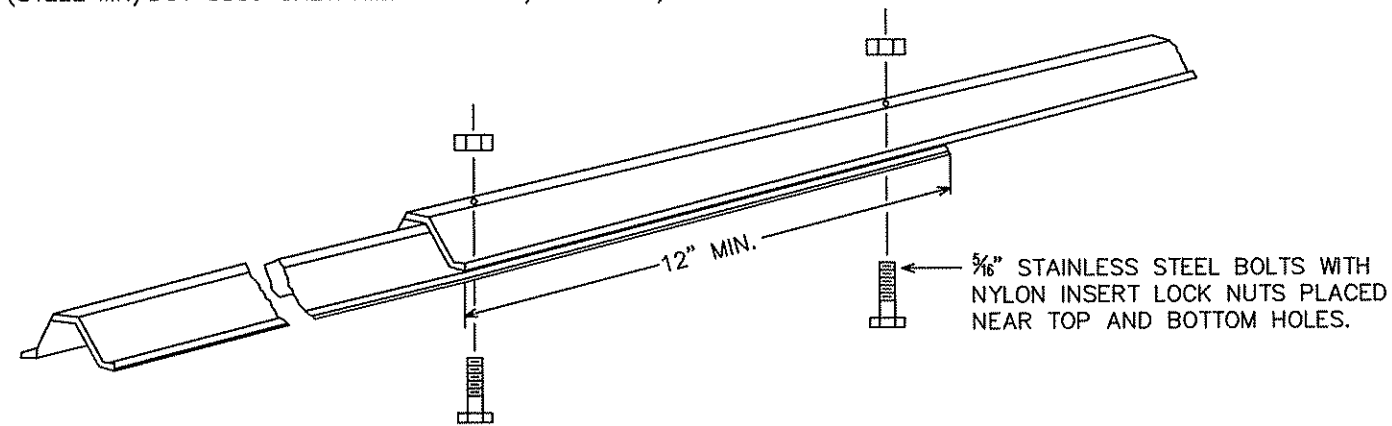

KNEE BRACE SPLICE

5/16" STAINLESS STEEL  
BOLTS WITH NYLON  
INSERT LOCK NUTS

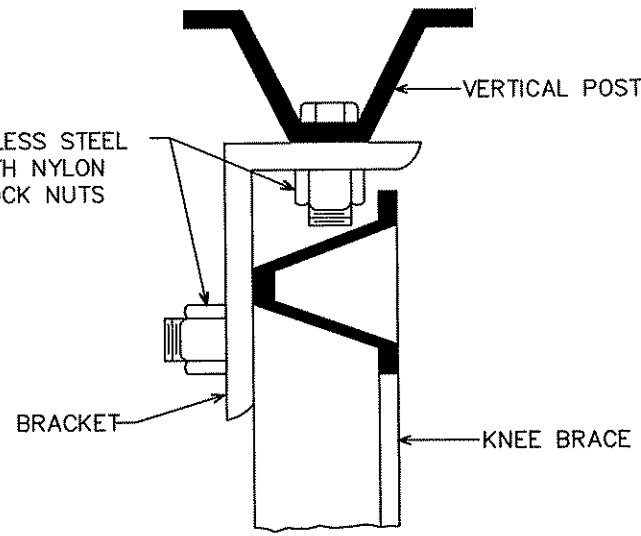

SECTION A-A

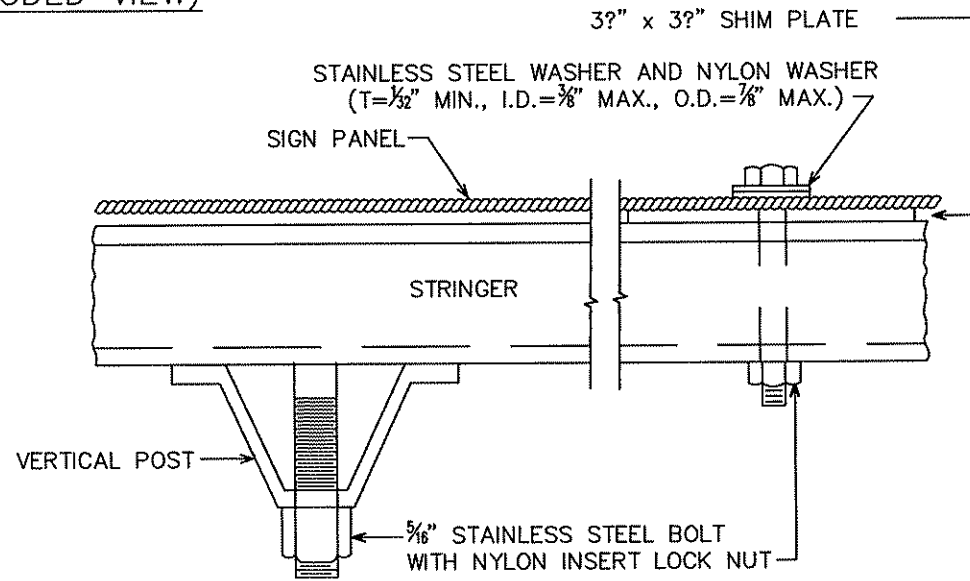

SECTION B-B

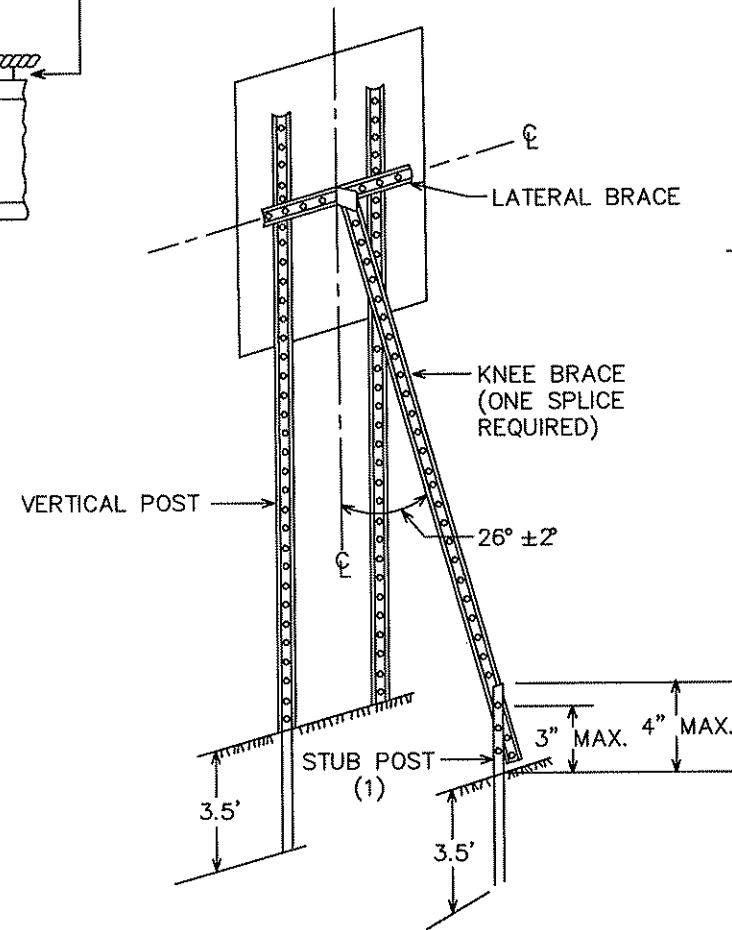

TYPICAL "A-FRAME" INSTALLATION  
TYPE "C" SIGNS

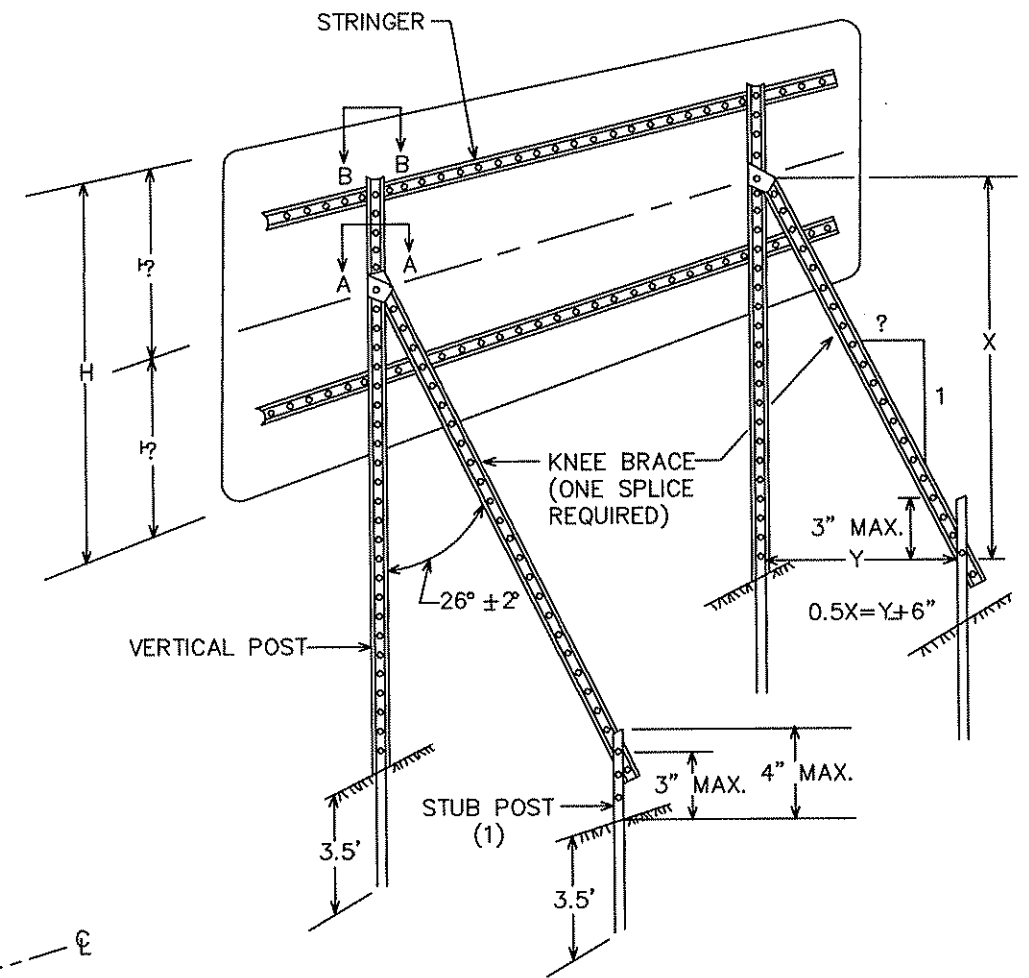

TYPICAL "A-FRAME" INSTALLATION  
TYPE "D" SIGNS

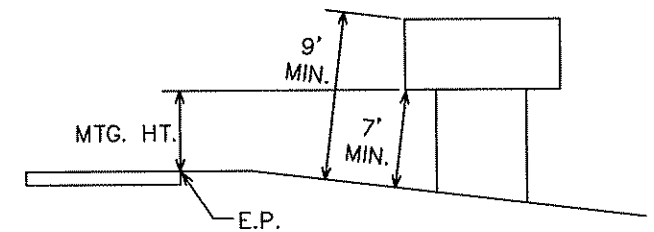

TYPICAL MOUNTING

(1) OFFSET STUB POST 1' TOWARD ROADWAY  
RELATIVE TO VERTICAL POST. ATTACH STUB  
POST AND KNEE BRACE BACK TO BACK.

TYPE C & D SIGN  
STRUCTURAL DETAILS

Sheet 2 of 2

**PROJECT LOCATION AND GENERAL INFORMATION**

THIS ROAD CONSTRUCTION PROJECT ADDS A CONCRETE WALKWAY ALONG THE SOUTH SIDE OF CSAH 14 (MAIN STREET) BETWEEN WEDGEWOOD DRIVE AND ROUND LAKE BOULEVARD (CSAH 9).

THIS PROJECT WILL PRIMARILY CONSIST OF GRADING FOR THE ADDITION OF A CONCRETE SIDEWALK ALONG THE SOUTH SIDE OF CSAH 12. ADDITIONAL WORK WILL INCLUDE THE ADDITION OF CONCRETE J BARRIER ACROSS THE BRIDGE AND CONCRETE CURB AND GUTTER WORK ADJACENT TO CSAH 14. LANE RE-STRIPING, GUARD RAIL ADDITION, AND FENCING WILL ALSO OCCUR WITH THIS PROJECT.

THIS PROJECT WILL REQUIRE THE DISTURBANCE OF 1.53 ACRES OF SOILS AND DOES CREATE THE POTENTIAL FOR SEDIMENT DISCHARGE FROM THE SITE.

**TRAINING REQUIREMENTS**

THE CONTRACTOR WILL ENSURE THAT THE TRAINING REQUIRED IN PART 111.A.2 OF THE GENERAL STORMWATER PERMIT FOR CONSTRUCTION ACTIVITY IS COMPLIED WITH

THE INDIVIDUALS TRAINED AND THE TRAINING RECEIVED WILL BE RECORDED IN THE SWPPP BEFORE THE START OF CONSTRUCTION OR AS SOON AS PERSONNEL FOR THE PROJECT HAVE BEEN DETERMINED.

**LONG TERM OPERATION AND MAINTENANCE**

THE CITY OF COON RAPIDS STREETS DIVISION WILL BE RESPONSIBLE FOR THE LONG TERM OPERATION AND MAINTENANCE OF THE PERMANENT STORMWATER MANAGEMENT AND SNOW REMOVAL OPERATIONS ALONG THE PROPOSED WALK.

JIM LEWIS  
CITY OF COON RAPIDS STREETS SUPERVISOR  
11155 ROBINSON DRIVE  
COON RAPIDS, MN 55433  
OFFICE - (763) 767-6579

**RECEIVING SURFACE WATERS, DISCHARGE TO IMPAIRED WATERS & SPECIAL WATERS**

THE FOLLOWING TABLE BELOW IDENTIFIES ALL SURFACE WATERS WITHIN 1 MILE OF THE DISTURBED SOIL PROJECT BOUNDARIES, WHICH WILL RECEIVE STORMWATER RUNOFF FROM THE CONSTRUCTION SITE, DURING OR AFTER CONSTRUCTION.

STORMWATER FROM A DISCHARGE POINT ON THE PROJECT THAT FLOWS TO A SURFACE WATER IDENTIFIED AS IMPAIRED AND/OR SPECIAL MUST INCLUDE THE FOLLOWING ADDITIONAL BMP REQUIREMENTS:

- ALL EXPOSED SOIL AREAS MUST BE STABILIZED AS SOON AS POSSIBLE TO LIMIT SOIL EROSION BUT IN NO CASE LATER THEN SEVEN (7) DAYS AFTER THE CONSTRUCTION ACTIVITY IN THAT PORTION OF THE SITE HAS TEMPORARILY OR PERMANENTLY CEASED.
- TEMPORARY SEDIMENT BASINS MUST BE USED FOR COMMON DRAINAGE LOCATIONS THAT SERVE AN AREA WITH FIVE (5) OR MORE ACRES DISTURBED AT ONE TIME. THIS PROJECT AS DESIGNED DOES NOT HAVE FIVE (5) DISTURBED ACRES DRAINING TO A COMMON LOCATION AND TEMPORARY SEDIMENT BASINS WILL NOT BE REQUIRED.

RECEIVING SURFACE WATERS		
NAME OF WATER BODY	SPECIAL WATER	IMPAIRED WATER
ANOKA COUNTY		
CROOKED LAKE	NO	YES
RUM RIVER	YES	YES

**DISTURBED SOIL AREA**

TOTAL DISTURBED SOILS AREA FOR THIS PROJECT IS 1.53 ACRES

**IMPERVIOUS SOIL AREA**

EXISTING AREA OF IMPERVIOUS SURFACE IS 0.05 ACRES.  
POST CONSTRUCTION AREA OF IMPERVIOUS SURFACE 0.22 ACRES.

**SOIL TYPES**

THE PREDOMINANT SOIL TYPE FOUND ON THIS PROJECT IS SAND.

**CONSTRUCTION PHASING**

SILT FENCE AND/OR OTHER SUITABLE PERIMETER BMP'S AS PROVIDED IN THE PLANS WILL BE INSTALLED PRIOR TO THE START OF ANY LAND DISTURBING ACTIVITY. CONSTRUCTION WILL BE REQUIRED TO BE PHASED SO THAT ALL DOWN GRADIENT SEDIMENT CONTROL MEASURES ARE INSTALLED PRIOR TO OR IN CONJUNCTION WITH ANY SOIL DISTURBING ACTIVITIES.

WHEN TOPSOIL IS DISTURBED, THE TOPSOIL WILL BE STRIPPED AND STOCKPILED IN SOIL BERMS AT THE TOE OF THE STRIPPED SLOPES ALONG THE PROJECT LIMITS. TEMPORARY VEGATATION WILL BE ESTABLISHED ON THE STOCKPILED TOPSOIL BERMS WITH SEED MIXTURE 150, TYPE 1 FERTILIZER, AND DISK ANCHORED TYPE 1 MULCH AS PROVIDED IN THE PLAN. STOCKPILED TOPSOIL BERMS WILL NOT BE PLACED IN ANY STORMWATER CONVEYANCES.

AFTER STRIPING THE TOPSOIL THE EXPOSED SOIL INSLOPES WILL BE STABILIZED WITH DISK ANCHORED TYPE 1 MULCH WITHIN 14 DAYS AFTER THE CONSTRUCTION ACTIVITY IN THAT PORTION OF THE SITE HAS BEEN TEMPORARILY OR PERMANENTLY CEASED.

**TEMPORARY SEDIMENT BASINS**

THIS ROAD CONSTRUCTION PROJECT AS DESIGNED DOES NOT MEET ANY OF THE TEMPORARY SEDIMENT BASIN DISTURBED AREA THRESHOLD REQUIREMENTS AND TEMPORARY SEDIMENT BASINS WILL NOT BE REQUIRED.

**PERMANENT STORMWATER MANAGEMENT SYSTEM**

ALL STORMWATER MUST BE DISCHARGED IN A MANNER THAT DOES NOT CAUSE NUISANCE CONDITIONS, EROSION IN RECEIVING WATERS OR ON DOWNSLOPE PROPERTIES, OR INUNDATION IN WETLANDS CAUSING A SIGNIFICANT ADVERSE IMPACT TO THE WETLAND.

THIS ROAD CONSTRUCTION PROJECT HAS A LESS THEN 1 ACRE INCREASE IN IMPERVIOUS AREA.

**EROSION PREVENTION PRACTICES**

ALL EXPOSED SOIL AREAS MUST BE STABILIZED AS SOON AS POSSIBLE TO LIMIT SOIL EROSION BUT IN NO CASE LATER THEN 14 DAYS AFTER THE CONSTRUCTION ACTIVITY IN THAT PORTION OF THE SITE HAS TEMPORARILY OR PERMANENTLY CEASED. FOR ALL AREAS WHERE DISTURBED SOILS DRAIN TO AN IMPAIRED OR SPECIAL WATER THE EXPOSED SOIL MUST BE STABILIZED NO LATER THEN 7 DAYS AFTER THE CONSTRUCTION ACTIVITY IN THAT AREA CEASED. SEE THE IMPAIRED & SPECIAL WATERS SECTION OF THIS SWPPP FOR ADDITIONAL BMP REQUIREMENTS FOR DISTURBED AREAS THAT DRAIN TO A SPECIAL OR IMPAIRED WATER

THE NORMAL WETTED PERIMETER OF ANY TEMPORARY OR PERMANENT DRAINAGE DITCH OR SWALE THAT DRAIN WATER FROM ANY PORTION OF THE CONSTRUCTION SITE, OR DIVERTS WATER AROUND THE SITE, MUST BE STABILIZED WITHIN 200 LINEAL FEET FROM THE POINT OF DISCHARGE INTO ANY SURFACE WATER. STABILIZATION OF THE LAST 200 FEET MUST BE COMPLETED WITHIN 24 HOURS AFTER CONNECTING TO A SURFACE WATER.

PIPE CULVERT OUTLETS MUST BE PROVIDED WITH TEMPORARY OR PERMANENT ENERGY DISSIPATION WITHIN 24 HOURS AFTER CONNECTION TO A SURFACE WATER. THIS WILL INCLUDE DRAINAGE DITCHES THAT DRAIN WATER FROM ANY PORTION OF THE CONSTRUCTION SITE

**PROJECT CONTACTS**

MPCA	NPDES	LAURAL MEZNER	218-316-3889
MPCA	EMERGENCY	STATE DUTY OFFICER	800-422-0798
DNR	NOT REQUIRED		
COE	NOT REQUIRED		
ANOKA COUNTY DESIGN SWPPP PREPARATION	U OF MN DESIGN OF SWPPP EXPIRES 5/13	NICK DOBDA	763-862-4261
ANOKA COUNTY PROJECT REPRESENTATIVE	U OF MN SITE MANAGEMENT EXPIRES 5/12	CHRIS OSTERHUS	763-862-4252
EROSION CONTROL SUPERVISOR (CONTRACTOR)			

**SEDIMENT CONTROL PRACTICES**

TEMPORARY STOCKPILED TOPSOIL BERMS MUST INCLUDE PERIMETER BMP'S AS PROVIDED IN THE PLAN AT LOCATIONS WHERE CONSTRUCTION STORMWATER DRAINS FROM THE PROJECT

IN ORDER TO MAINTAIN SHEET FLOW AND MINIMIZE RILLS AND/OR GULLIES, THERE SHALL BE NO UNBROKEN SLOPE LENGTH OF GRATER THEN 75 FEET FOR SLOPES WITH A GRADE OF 1:3 OR STEEPER

ALL STORM DRAIN INLETS MUST BE PROTECTED BY APPROPRIATE BMP'S DURING CONSTRUCTION UNTIL ALL SOURCES WITH POTENTIAL DISCHARGE TO THE INLET HAVE BEEN STABILIZED

VEHICLE TRACKING OF SEDIMENT FROM THE CONSTRUCTION SITE MUST BE MINIMIZED. STREET SWEEPING MUST BE USED IF SEDIMENT IS BEING TRACKED OFF THE CONSTRUCTION SITE

**POLLUTION PREVENTION MEASURES**

THE CONTRACTOR WILL IMPLEMENT THE POLLUTION PREVENTION MANAGEMENT MEASURES AS DIRECTED IN THE NPDES PERMIT PART IV.F AS PERTAINING TO SOLID WASTE, HAZARDOUS MATERIALS EXTERNAL TRUCK WASHING, AND CONCRETE WASHOUT ONSITE.

THESE MANAGEMENT MEASURES FOR POLLUTION PREVENTION WILL BE STRICTLY ENFORCED.

**LOCATION OF SWPPP REQUIREMENTS**

REQUIREMENT	PLAN		MNDOT SPECIFICATION	SPECIAL PROVISION
	TITLE	LOCATION		
NPDES PERMIT COMPLIANCE			1701, 1702, & 1717	1717 (AIR, LAND & WATER) 1717 (NATIONAL POLLUTANT DISCHARGE ELIMINATION SYSTEM (NPDES) PERMIT)
CERTIFIED PERSONNEL IN EROSION AND SEDIMENT CONTROL SITE MANAGEMENT			1506, 1717, & 2573	1717 (AIR, LAND & WATER) 1717 (NATIONAL POLLUTANT DISCHARGE ELIMINATION SYSTEM (NPDES) PERMIT)
CHAIN OF RESPONSIBILITY	AGENCY CONTACTS	SHEET 30	1506, 1717, & 2573	
PROJECT SCHEDULE / WEEKLY EROSION & SEDIMENT CONTROL SCHEDULE / COMPLETING INSPECTION / MAINTENANCE LOG	AGENCY CONTACTS	SHEET 30	1717 & 2573	1717 (AIR, LAND & WATER) 1717 (NATIONAL POLLUTANT DISCHARGE ELIMINATION SYSTEM (NPDES) PERMIT)
SWPPP PREPARATION	AGENCY CONTACTS	SHEET 30		
SITE MAP / RECEIVING WATERS / DIRECTION OF FLOW			1717	
PROJECT SPECIFIC CONSTRUCTION STAGING			1717	1717 (AIR, LAND & WATER) 1717 (NATIONAL POLLUTANT DISCHARGE ELIMINATION SYSTEM (NPDES) PERMIT) 1806 (DETERMINATION AND EXTENSION OF CONTRACT TIME)
TEMPORARY EROSION AND SEDIMENT CONTROL BMP LOCATIONS, INSTALLATION, TIMING OF INSTALLATION AND TYPE OF BMP	QUANTITY TABULATIONS	SHEET 5	2573 & 2525	2575 (RAPID STABILIZATION SPECIFICATION)
ADDITIONAL TEMPORARY AND OR PERMANENT EROSION AND SEDIMENT CONTROL BMP'S NOT PROVIDED OR SHOWN IN THE PLAN			1717, 2573, & 2575	1717 (AIR, LAND & WATER) 1717 (NATIONAL POLLUTANT DISCHARGE ELIMINATION SYSTEM (NPDES) PERMIT) 2575 (RAPID STABILIZATION SPECIFICATION)
MAINTENANCE OF EROSION AND SEDIMENT CONTROL DEVICES, REMOVAL OF TRACKED SEDIMENT, REMOVAL OF DEVICES			1717 & 2573	1514 (MAINTENANCE DURING CONSTRUCTION) 1717 (LAND AIR & WATER) 1717 (NATIONAL POLLUTANT DISCHARGE ELIMINATION SYSTEM (NPDES) PERMIT)
DEWATERING			2105.3B, & 2451.3C	DEWATERING MAY ALSO REQUIRE DNR PERMIT. NO DEWATERING IS ANTICIPATED FOR THIS PROJECT
FINAL STABILIZATION	QUANTITY TABULATIONS EROSION CONTROL PLAN	SHEET 5 SHEET 32 - 33	1717, 2573, & 2575	1717 (AIR, LAND & WATER) 1717 (NATIONAL POLLUTANT DISCHARGE ELIMINATION SYSTEM (NPDES) PERMIT)
TEMPORARY EROSION AND SEDIMENT CONTROL DETAILS	QUANTITY TABULATIONS EROSION CONTROL PLAN	SHEET 5 SHEET 32 - 33	2575	2575 (RAPID STABILIZATION SPECIFICATION)
PERMANENT EROSION CONTROL DETAILS	EROSION CONTROL DETAILS	SHEET 34 - 36	2575	2575 (CONTROLLING EROSION AND ESTABLISHING VEGETATION)

NO	DATE	BY	CKD	APPR	REVISION
NAME: p:\14_ped\plan\14_PED_SWPPP.dgn					

I HEREBY CERTIFY THAT THIS PLAN WAS PREPARED BY ME OR UNDER MY DIRECT SUPERVISION AND THAT I AM A DULY LICENSED PROFESSIONAL ENGINEER UNDER THE LAWS OF THE STATE OF MINNESOTA.  
PRINT NAME: CURT A. KOBILARCSIK  
SIGNATURE: *[Signature]*  
DATE: 12-9-10 LICENSE NO. 24756

DRAWN BY: NJD DATE: 11-30-10  
DESIGN BY: NJD DATE: 11-30-10  
CHECKED BY: JEO DATE: 11-30-10



**ANOKA COUNTY  
HIGHWAY DEPT.**

STATE AID PROJECT NO. 02-614-37  
COON RAPIDS CITY NO. 06-48.  
MN STATE PROJECT NO. 114-020-40

SWPPP PLAN



## STORM WATER POLLUTION PREVENTION PLAN (SWPPP)

### Training

Individual revising or amending the SWPPP and individuals performing inspections must fill in the following table.

<b>Name of on-site personel trained</b>	
<b>Dates of training</b>	
<b>Name of instructor(s)</b>	
<b>Entity providing training</b>	
<b>Content of training course or workshop</b>	

### Amending the SWPPP

The SWPPP must be amended to record changes or modifications to permanent BMP's or other storm water treatment systems and removals of temporary BMP's. Changes to temporary BMP's may be recorded on this sheet. Include a brief description of the problem, location, nature of alteration, and comments. This record is to be retained for three years after project completion.

Date Reported	Plan Location (sheet)	Project Location (station)	Problem, solution, and notes

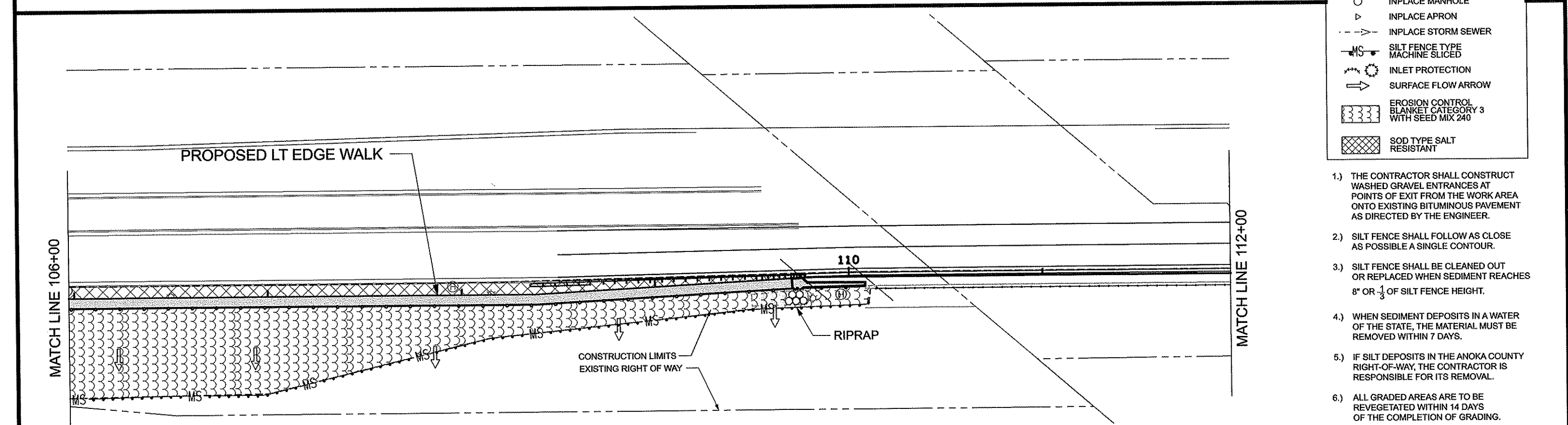
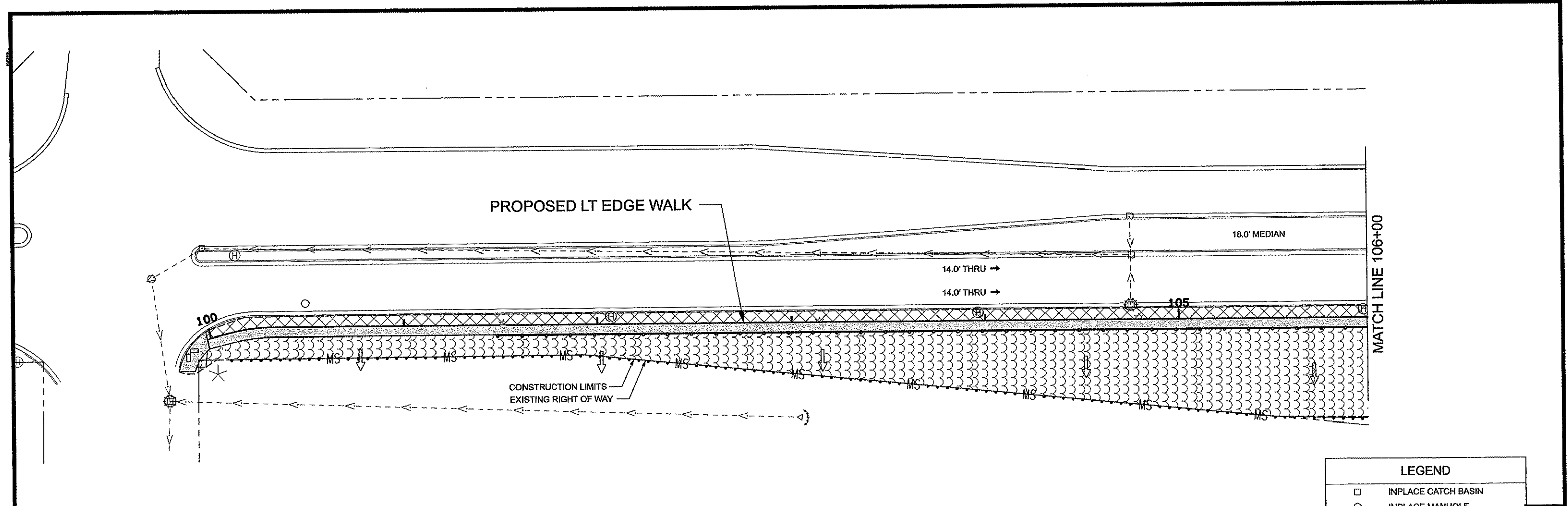

LEGEND	
□	INPLACE CATCH BASIN
○	INPLACE MANHOLE
▽	INPLACE APRON
- - - ▽	INPLACE STORM SEWER
MS	SILT FENCE TYPE MACHINE SLICED
⊙	INLET PROTECTION
→	SURFACE FLOW ARROW
	EROSION CONTROL BLANKET CATEGORY 3 WITH SEED MIX 240
XXXXX	SOD TYPE SALT RESISTANT

- 1.) THE CONTRACTOR SHALL CONSTRUCT WASHED GRAVEL ENTRANCES AT POINTS OF EXIT FROM THE WORK AREA ONTO EXISTING BITUMINOUS PAVEMENT AS DIRECTED BY THE ENGINEER.
- 2.) SILT FENCE SHALL FOLLOW AS CLOSE AS POSSIBLE A SINGLE CONTOUR.
- 3.) SILT FENCE SHALL BE CLEANED OUT OR REPLACED WHEN SEDIMENT REACHES 8" OR  $\frac{1}{3}$  OF SILT FENCE HEIGHT.
- 4.) WHEN SEDIMENT DEPOSITS IN A WATER OF THE STATE, THE MATERIAL MUST BE REMOVED WITHIN 7 DAYS.
- 5.) IF SILT DEPOSITS IN THE ANOKA COUNTY RIGHT-OF-WAY, THE CONTRACTOR IS RESPONSIBLE FOR ITS REMOVAL.
- 6.) ALL GRADED AREAS ARE TO BE REVEGETATED WITHIN 14 DAYS OF THE COMPLETION OF GRADING.

NO	DATE	BY	CHKD	APPR	REVISION

NAME: p:\14\_ped\plan14\_PED\_EC2\_P1.dgn 12/01/2010 2:15:23 PM

I HEREBY CERTIFY THAT THIS PLAN WAS PREPARED BY ME OR UNDER MY DIRECT SUPERVISION AND THAT I AM A DULY LICENSED PROFESSIONAL ENGINEER UNDER THE LAWS OF THE STATE OF MINNESOTA.

PRINT NAME: CURT A. KOBILARCSIK  
 SIGNATURE: *Curt A. Kobilarsik*  
 DATE: 12-9-10 LICENSE NO. 24758

DRAWN BY: NJD DATE: 8-20-10  
 DESIGN BY: NJD DATE: 5-26-10  
 CHECKED BY: JEO DATE: 11-29-10

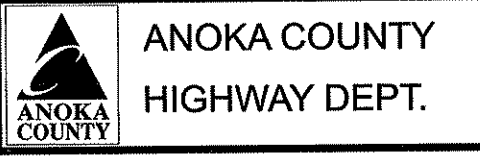

STATE AID PROJECT NO. 02-614-37  
 COON RAPIDS CITY NO. 06-48  
 MN STATE PROJECT NO. 114-020-40

EROSION CONTROL PLAN  
 STA 100+00.00 TO 112+00.00  
 Sheet 32 of 51 Sheets

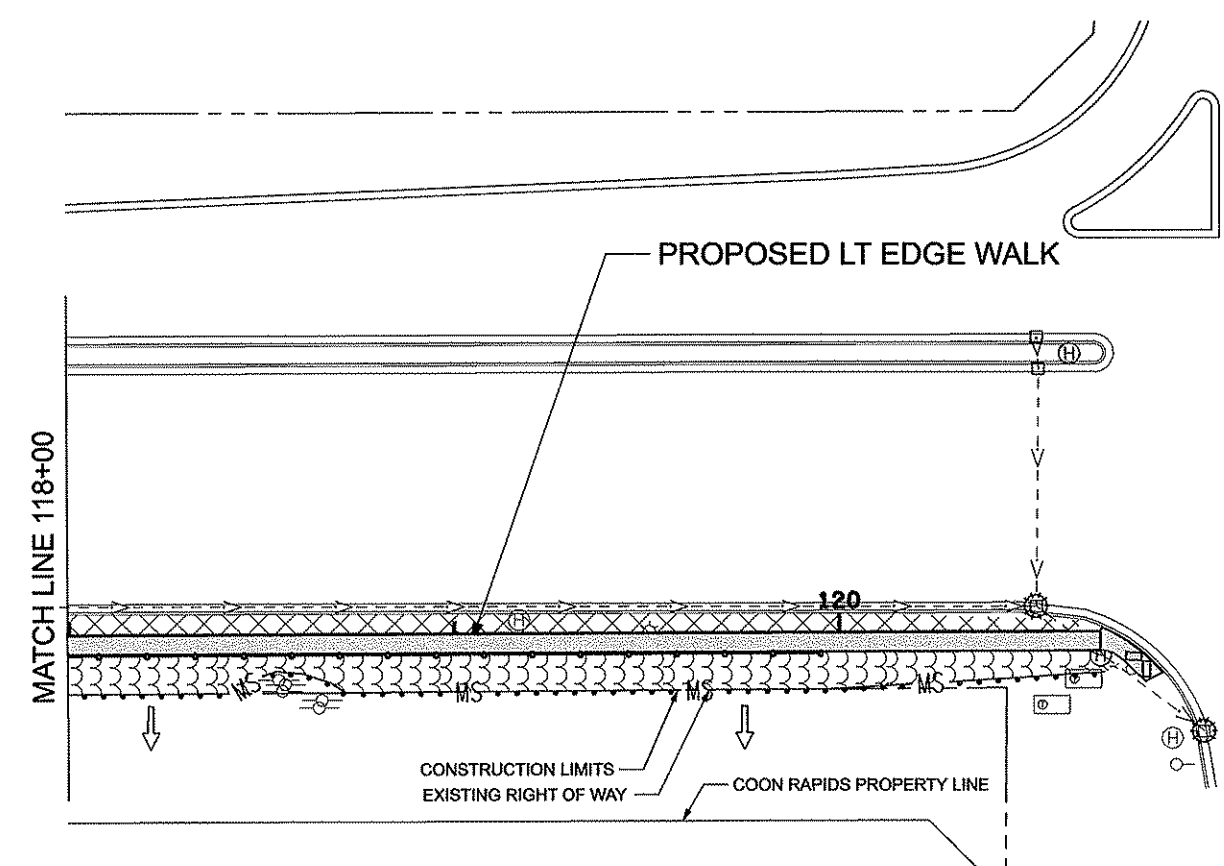
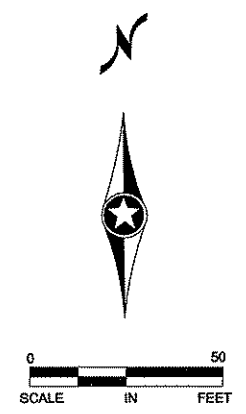
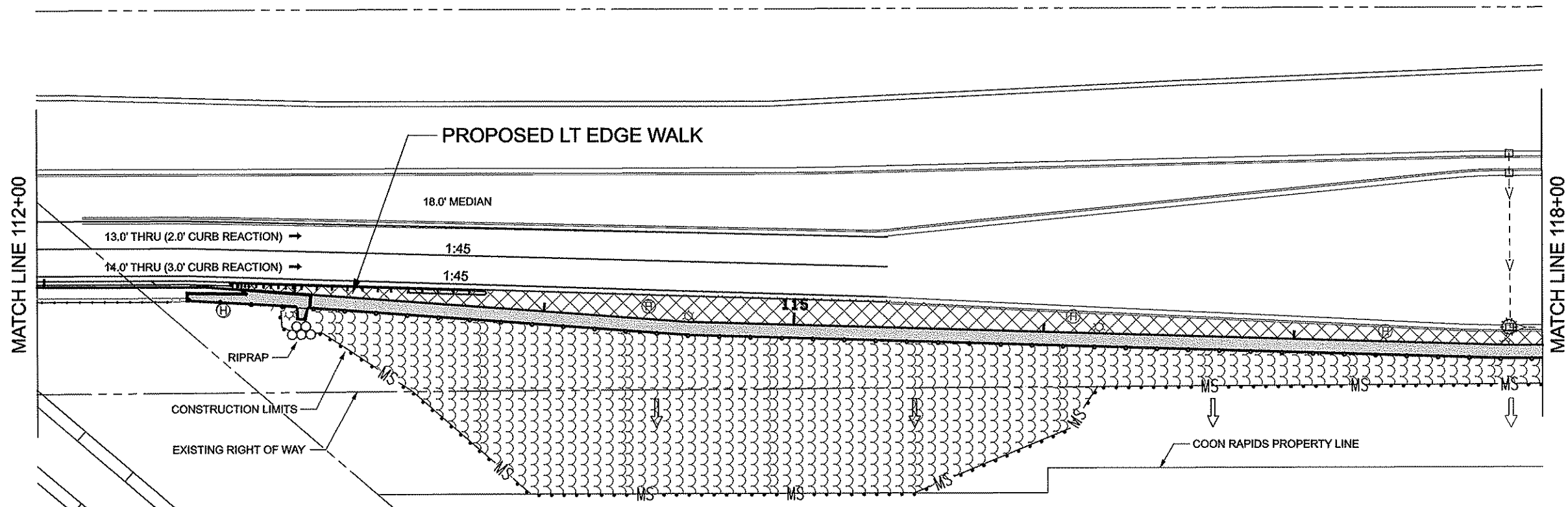

LEGEND	
	INPLACE CATCH BASIN
	INPLACE MANHOLE
	INPLACE APRON
	INPLACE STORM SEWER
	SILT FENCE TYPE MACHINE SLICED
	INLET PROTECTION
	SURFACE FLOW ARROW
	EROSION CONTROL BLANKET CATEGORY 3 WITH SEED MIX 240
	SOD TYPE SALT RESISTANT

- 1.) THE CONTRACTOR SHALL CONSTRUCT WASHED GRAVEL ENTRANCES AT POINTS OF EXIT FROM THE WORK AREA ONTO EXISTING BITUMINOUS PAVEMENT AS DIRECTED BY THE ENGINEER.
- 2.) SILT FENCE SHALL FOLLOW AS CLOSE AS POSSIBLE A SINGLE CONTOUR.
- 3.) SILT FENCE SHALL BE CLEANED OUT OR REPLACED WHEN SEDIMENT REACHES 8" OR  $\frac{1}{3}$  OF SILT FENCE HEIGHT.
- 4.) WHEN SEDIMENT DEPOSITS IN A WATER OF THE STATE, THE MATERIAL MUST BE REMOVED WITHIN 7 DAYS.
- 5.) IF SILT DEPOSITS IN THE ANOKA COUNTY RIGHT-OF-WAY, THE CONTRACTOR IS RESPONSIBLE FOR ITS REMOVAL.
- 6.) ALL GRADED AREAS ARE TO BE REVEGETATED WITHIN 14 DAYS OF THE COMPLETION OF GRADING.

I HEREBY CERTIFY THAT THIS PLAN WAS PREPARED BY ME OR UNDER MY DIRECT SUPERVISION AND THAT I AM A DULY LICENSED PROFESSIONAL ENGINEER UNDER THE LAWS OF THE STATE OF MINNESOTA.  
 PRINT NAME: CURT A. KOBIARCSIK  
 SIGNATURE: *Curt Kobilarcsik*  
 DATE: 12-9-10 LICENSE NO. 24756

DRAWN BY: NJD DATE: 8-20-10  
 DESIGN BY: NJD DATE: 8-20-10  
 CHECKED BY: JEO DATE: 10-29-10

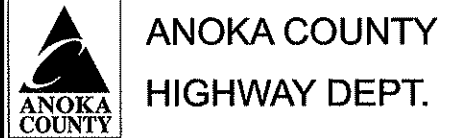

STATE AID PROJECT NO. 02-614-37  
 COON RAPIDS CITY NO. 06-48  
 MN STATE PROJECT NO. 114-020-40

EROSION CONTROL PLAN  
 STA 112+00.00 TO 120+60+00  
 Sheet 33 of 51 Sheets

NO	DATE	BY	CKD	APPR	REVISION

NAME: p:\14\_ped\plan\14\_PED\_EC2\_P2.dgn 12/01/2010 2:15:27 PM

PLOTTED/REVISED:  
12/01/2010

PATH & FILENAME: P:\V4\_PEDPlan\Standard Plans EC\405\_4\_spd.dgn

DISTRICT: METRO

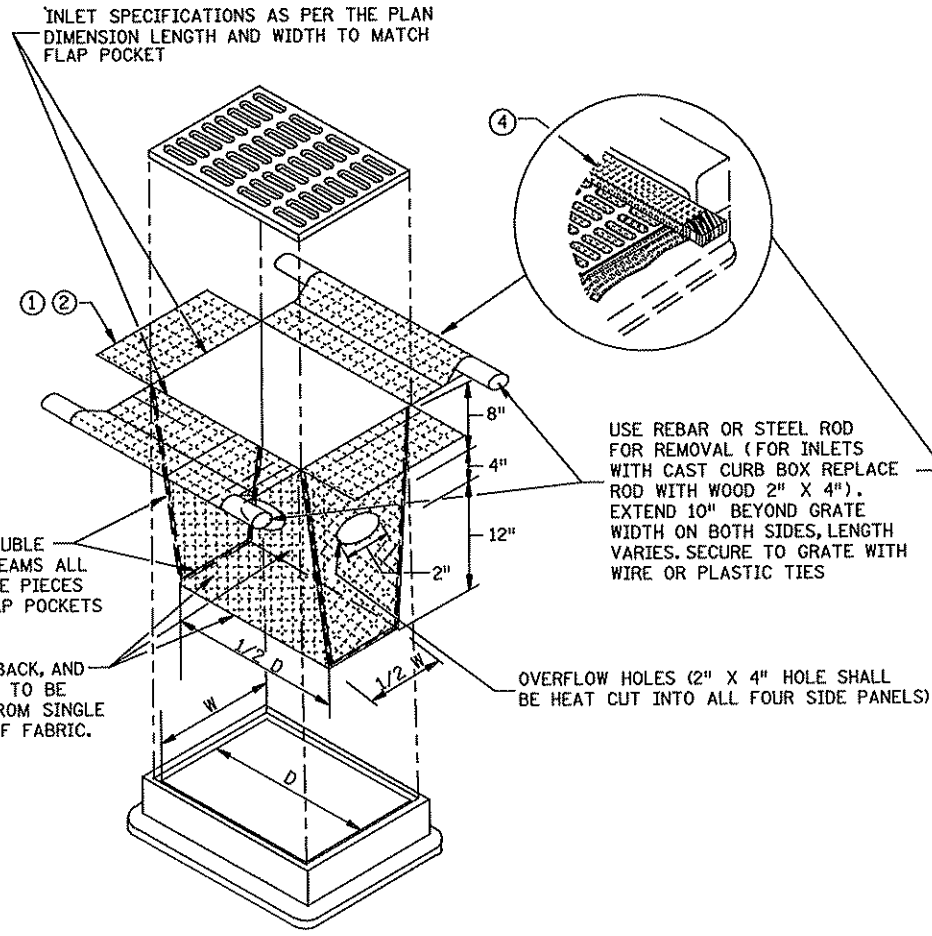

**FILTER BAG INSERT ③**  
(CAN BE INSTALLED IN ANY INLET TYPE  
WITH OR WITHOUT A CURB BOX)

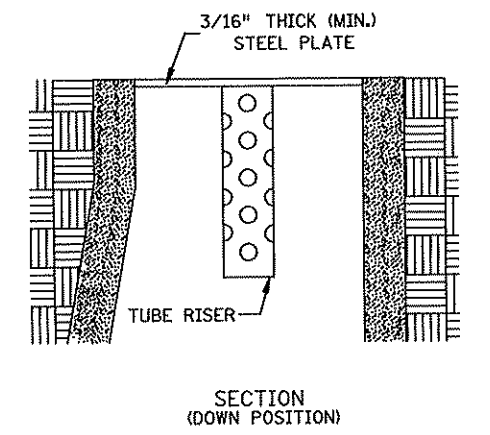
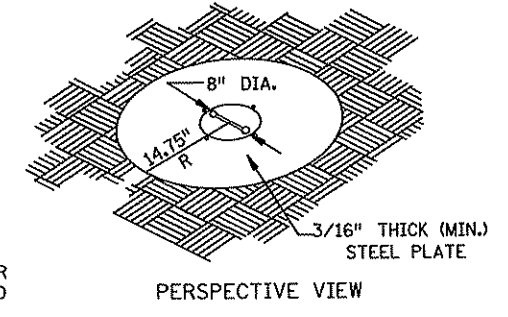
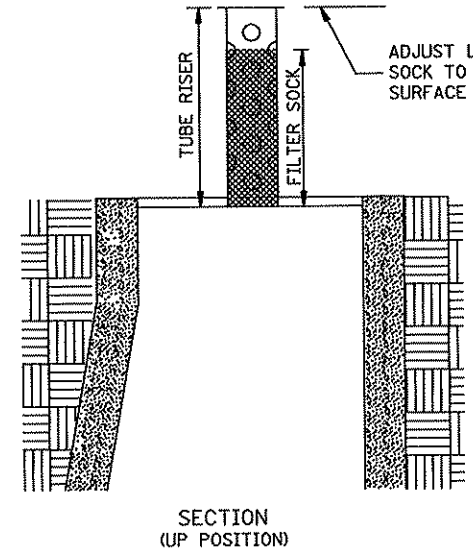
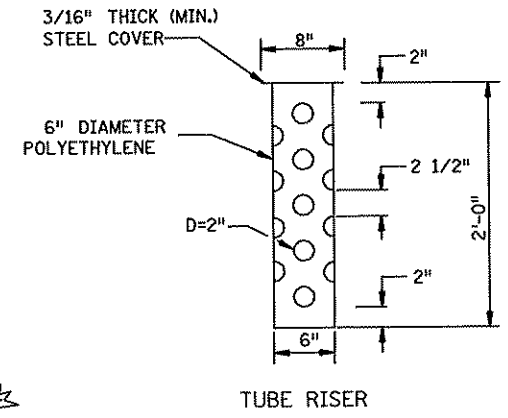
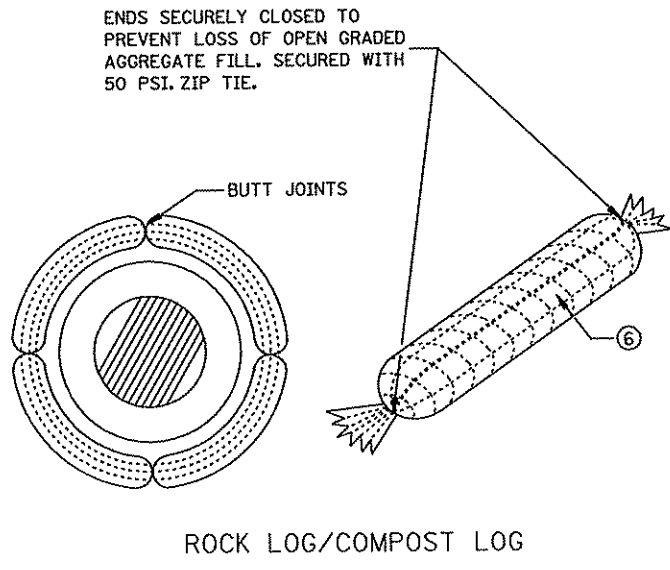

POP-UP HEAD

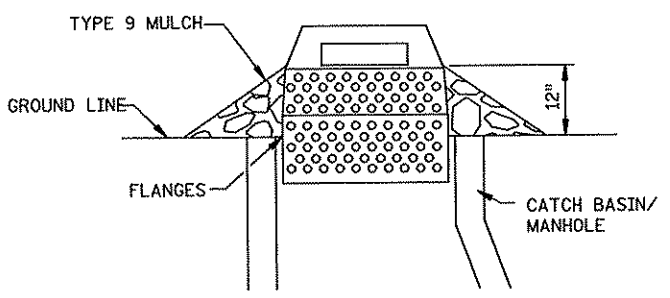

SEDIMENT CONTROL INLET HAT

NOTE:  
THE SEDIMENT CONTROL BARRIER SHALL BE A METAL  
OR PLASTIC/POLYETHYLENE RISER SIZED TO FIT INSIDE  
THE CATCH BASIN/MANHOLE; HAVE PERFORATIONS TO ALLOW  
FOR WATER INFILTRATION; HAVE AN OVERFLOW OPENING,  
FLANGES AND A LID/COVER.

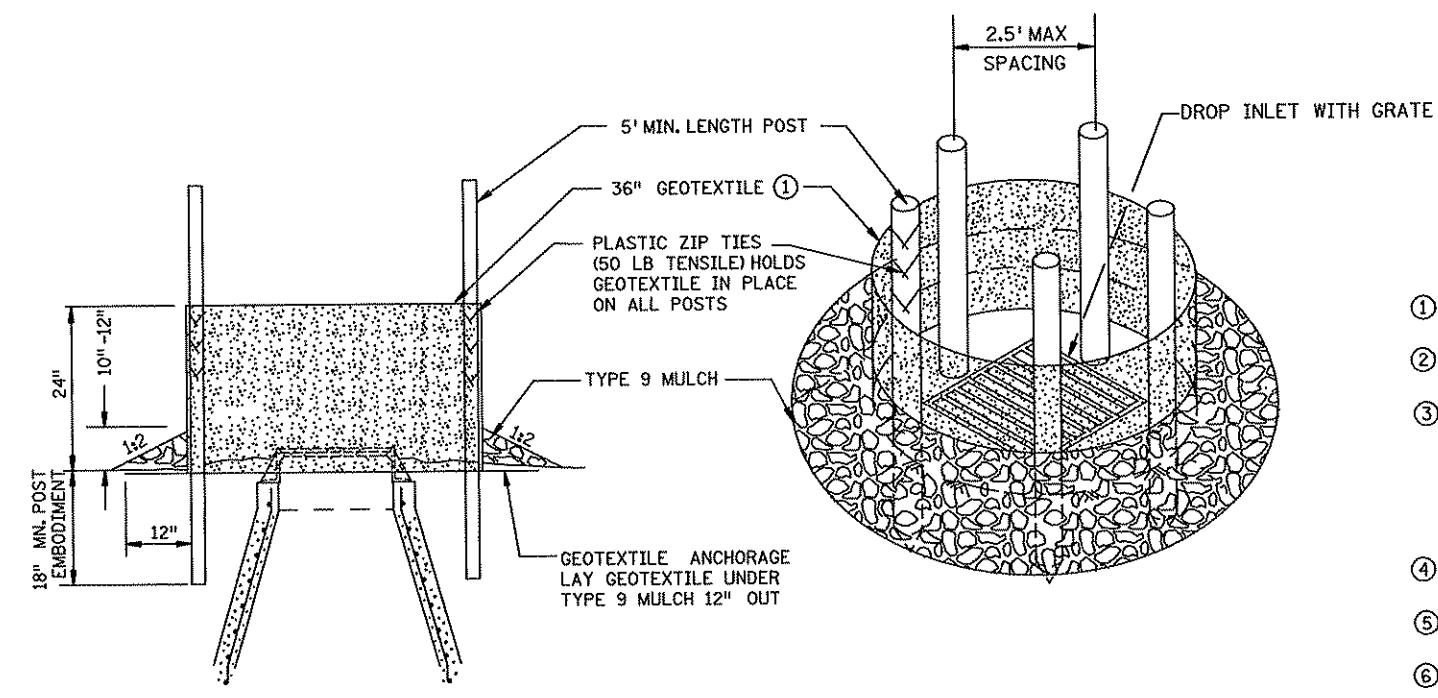

**SILT FENCE RING AND ROCK FILTER BERM**  
USE WHERE INLET DRAINS IN AN AREA WITH SLOPES AT 1:3 OR LESS

- NOTES:  
SEE SPECS. 2573, 3137, 3886 & 3891.
- MANUFACTURED ALTERNATIVES LISTED ON Mn/DOT'S APPROVED PRODUCTS LIST  
MAY BE SUBSTITUTED.
- ALL GEOTEXTILE USED FOR INLET PROTECTION SHALL BE MONOFILAMENT IN BOTH DIRECTIONS, MEETING SPEC. 3886.
  - FINISHED SIZE, INCLUDING POCKETS WHERE REQUIRED SHALL EXTEND A MINIMUM OF 10 INCHES AROUND THE PERIMETER TO FACILITATE MAINTENANCE OR REMOVAL.
  - INSTALLATION NOTES:  
DO NOT INSTALL FILTER BAG INSERT IN INLETS SHALLower THAN 30 INCHES, MEASURED FROM THE BOTTOM OF THE INLET TO THE TOP OF THE GRATE. THE INSTALLED BAG SHALL HAVE A MINIMUM SIDE CLEARANCE OF 3 INCHES BETWEEN THE INLET WALLS AND THE BAG, MEASURED AT THE BOTTOM OF THE OVERFLOW HOLES. WHERE NECESSARY THE CONTRACTOR SHALL CLINCH THE BAG, USING PLASTIC ZIP TIES, TO ACHIEVE THE 3 INCH SIDE CLEARANCE.
  - FLAP POCKETS SHALL BE LARGE ENOUGH TO ACCEPT WOOD 2 INCH X 4 INCH OR USE A ROCK SOCK OR SAND BAGS IN PLACE OF THE FLAP POCKETS.
  - SOCK HEIGHT MUST NOT BE SO HIGH AS TO SLOW DOWN WATER FILTRATION TO CAUSE FLOODING OF THE ROADWAY.
  - GEOTEXTILE SOCK BETWEEN 4-10 FEET LONG AND 4-6 INCH DIAMETER. SEAM TO BE JOINED BY TWO ROWS OF STITCHING WITH A PLASTIC MESH BACKING OR PROVIDE A HEAT BONDED SEAM (OR APPROVED EQUIVALENT). FILL ROCK LOG WITH OPEN GRADED AGGREGATE CONSISTING OF SOUND DURABLE PARTICLES OF COARSE AGGREGATE CONFORMING TO SPEC. 3137 TABLE 3137-1; CA-3 GRADATION.

STANDARD SHEET NO. 297.405 (4 OF 4)	TITLE: TEMPORARY SEDIMENT CONTROL STORM DRAIN INLET PROTECTION
STANDARD APPROVED: SEPTEMBER 27, 2006	
STATE AID PROJECT NO. 02-614-37 SHEET NO. 34 OF 51 SHEETS	

PLOTTED/REVISED:  
12/01/2010

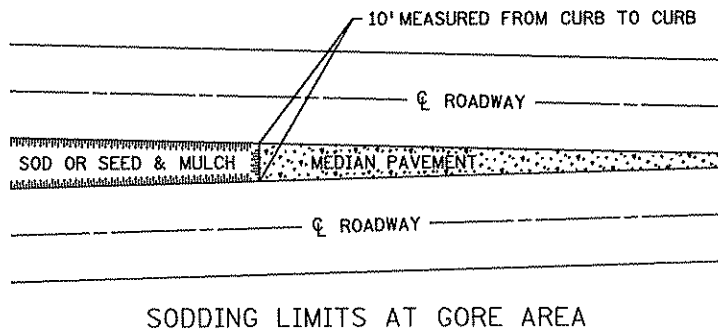

SODDING LIMITS AT GORE AREA

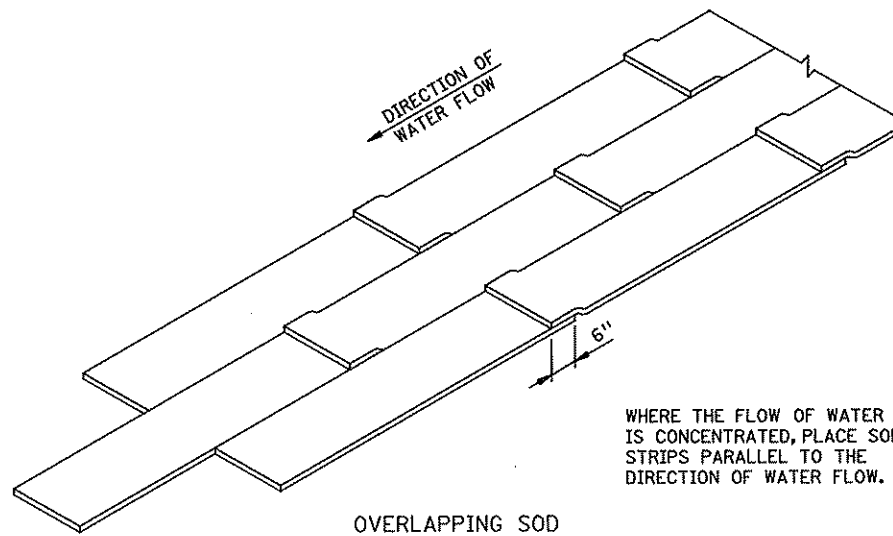

OVERLAPPING SOD

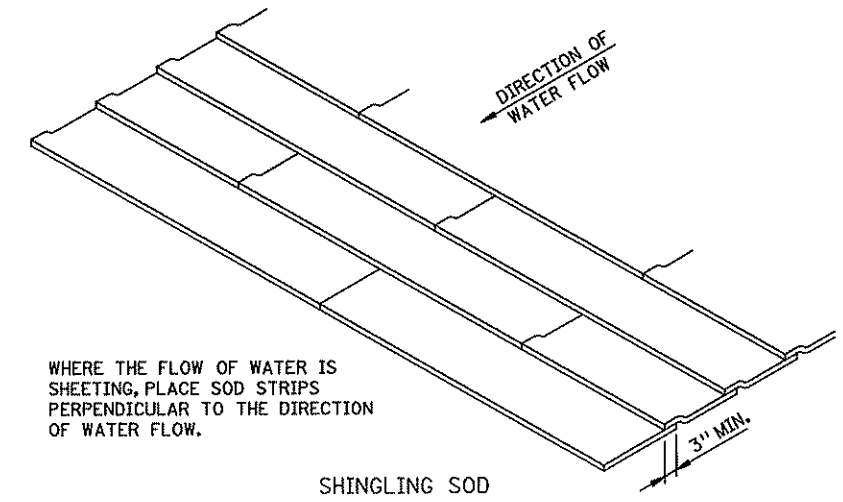

SHINGLING SOD

WHERE THE FLOW OF WATER IS CONCENTRATED, PLACE SOD STRIPS PARALLEL TO THE DIRECTION OF WATER FLOW.

WHERE THE FLOW OF WATER IS SHEETING, PLACE SOD STRIPS PERPENDICULAR TO THE DIRECTION OF WATER FLOW.

SPECIAL SOD PLACEMENT TECHNIQUES

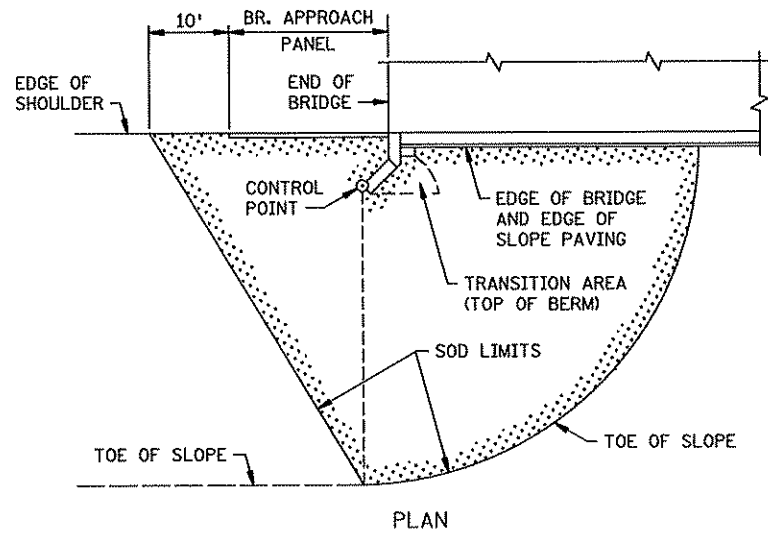

PLAN

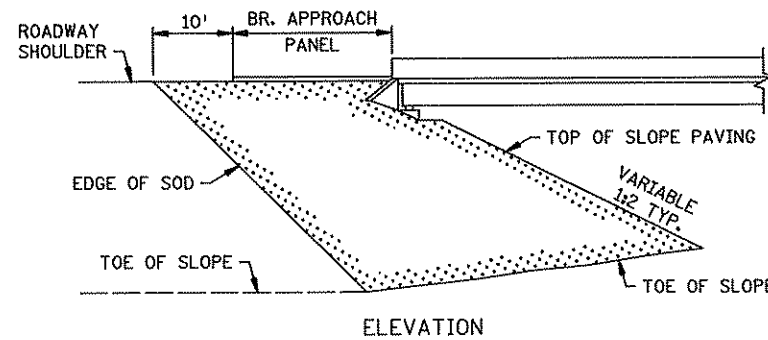

ELEVATION

SODDING LIMITS AT BRIDGE APPROACH FILLS

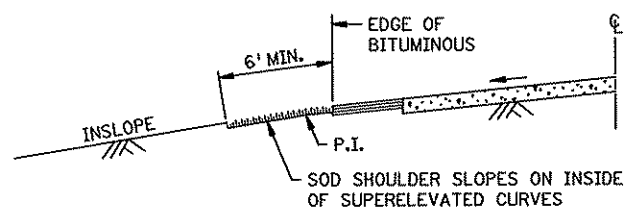

SODDING INSLOPES OF SUPERELEVATED CURVES

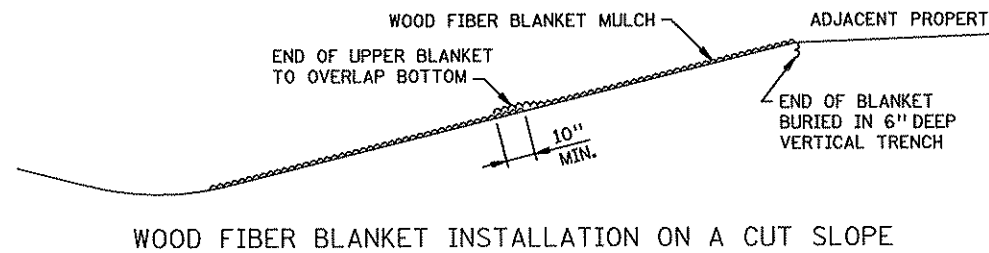

WOOD FIBER BLANKET INSTALLATION ON A CUT SLOPE

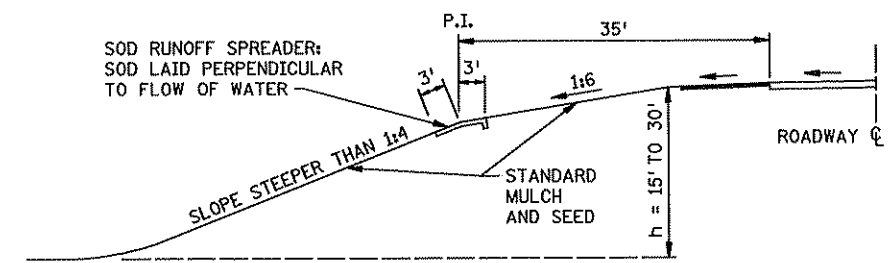

BROKEN-BACK SAFETY FILL SLOPE

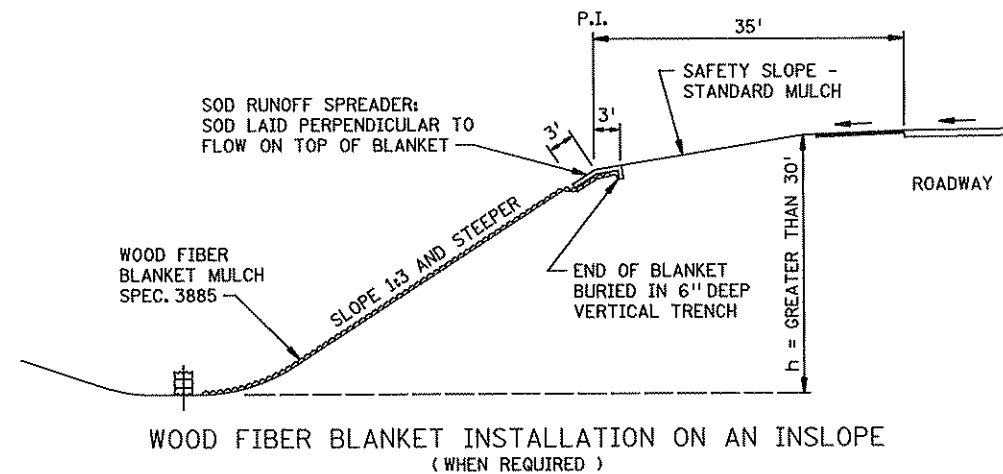

WOOD FIBER BLANKET INSTALLATION ON AN INSLOPE (WHEN REQUIRED)

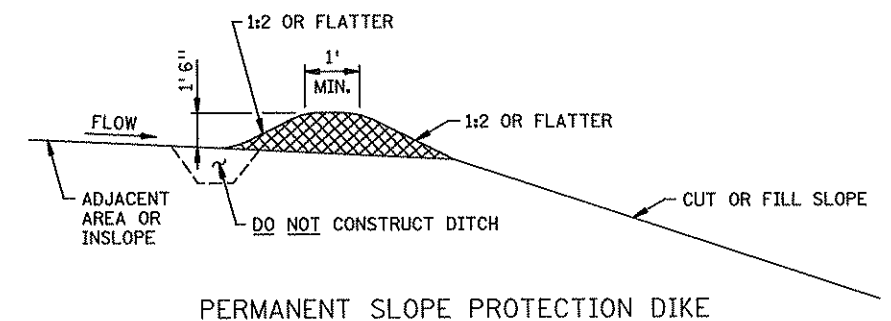

PERMANENT SLOPE PROTECTION DIKE

DISTRICT: METRO

PATH & FILENAME: P:\V4\_PED\Plan\Standard Plans EC\406\_L\_spm.dgn

STANDARD SHEET NO.  
5-297.406

STANDARD APPROVED:  
JANUARY 31, 1985

TITLE:

PERMANENT EROSION CONTROL  
ALONG ROADWAYS AND AT GORE AREAS & BRIDGE APPROACH FILLS

REVISION DATE  
10-26-2000

STATE AID PROJECT NO. 02-614-37

SHEET NO. 35 OF 51 SHEETS

PLOTTED/REVISED:  
12/01/2010

DISTRICT: METRO  
PATH & FILENAME: P:\V4\_PED\Plan\Standard Plans EC\408.J\_spdn.dgn

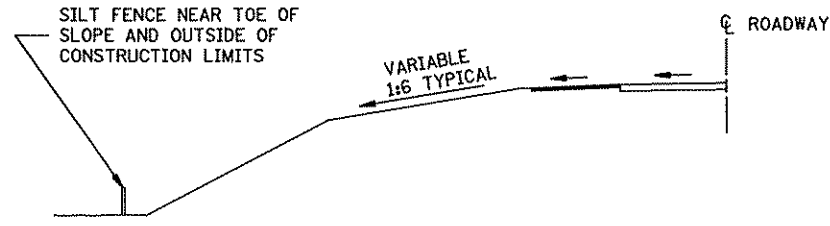

LOCATION OF SILT FENCE  
AT TOE OF ROADWAY EMBANKMENT

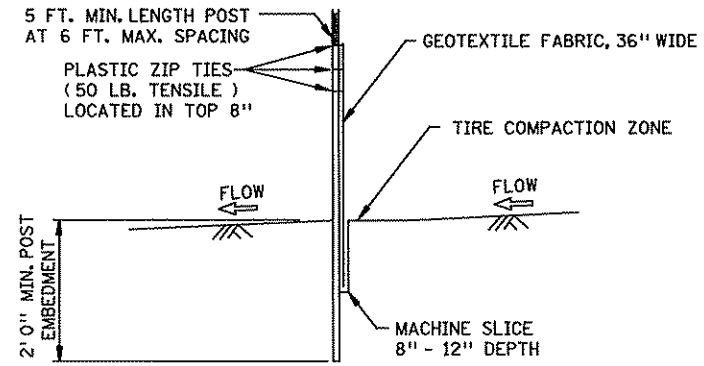

SILT FENCE, MACHINE SLICED  
DESIGN GUIDELINES:  
TO PROTECT AREAS FROM SHEET FLOW.  
MAXIMUM CONTRIBUTING AREA: 1 ACRE.

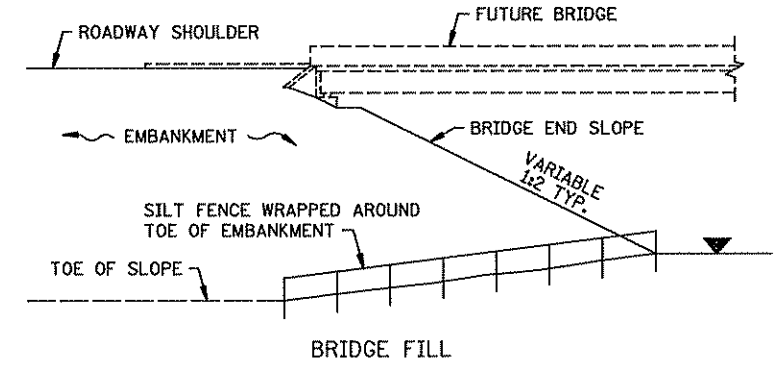

DESIGN GUIDELINES:  
WATER COURSE FLOW VELOCITY: STAGNANT  
CONTRIBUTING SLOPE AREA: 1/2 ACRE

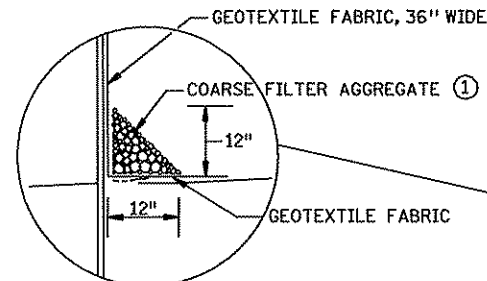

OPTIONAL METHOD  
FOR SILT FENCE, HEAVY DUTY

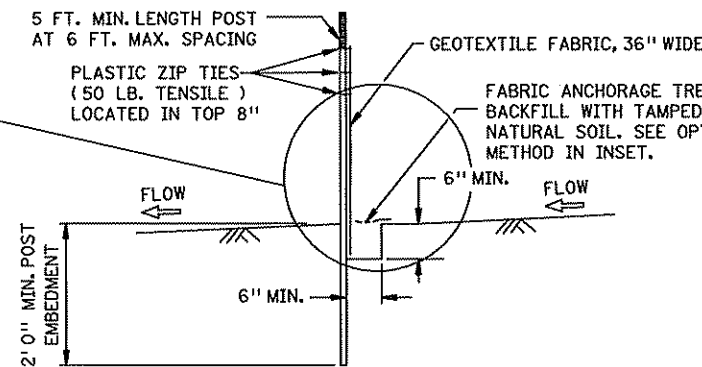

SILT FENCE, HEAVY DUTY  
(HAND INSTALLED)  
DESIGN GUIDELINES:  
TO PROTECT AREAS FROM SHEET FLOW.  
MAXIMUM CONTRIBUTING AREA: 1 ACRE.

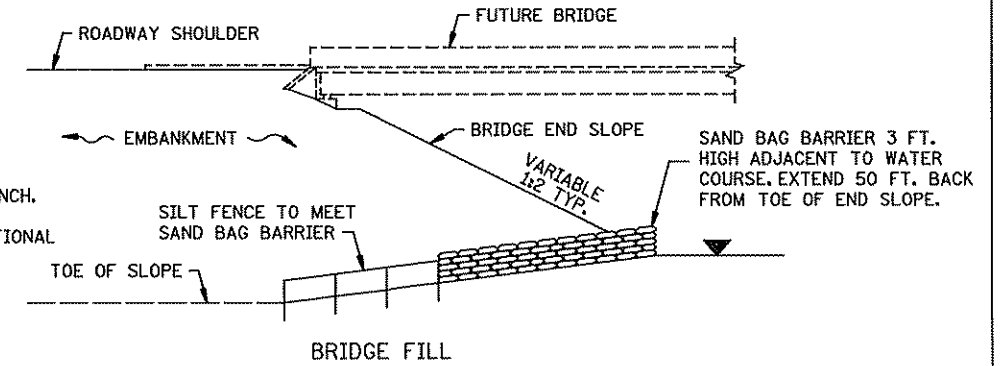

DESIGN GUIDELINES:  
WATER COURSE FLOW VELOCITY: 1 TO 7 FT./SEC.  
CONTRIBUTING SLOPE AREA: 1 ACRE

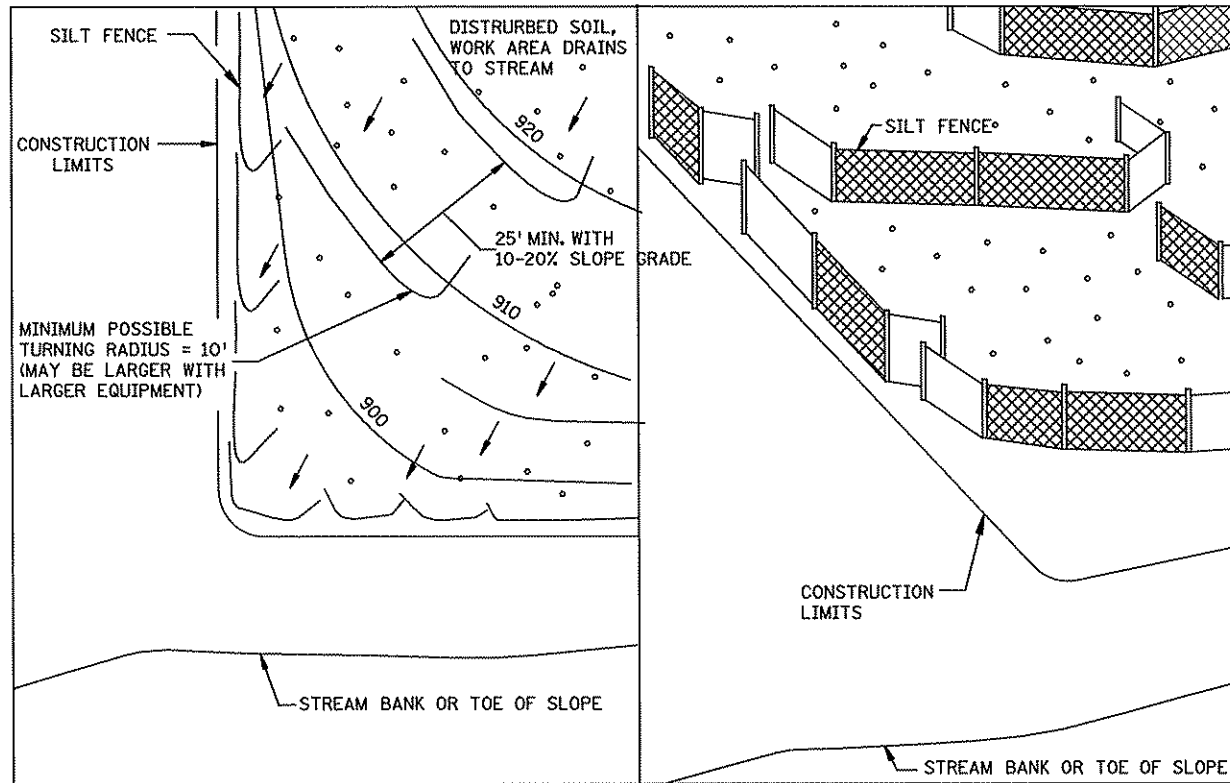

PLAN VIEW

SIDE VIEW

SILT FENCE, J-HOOK INSTALLATION

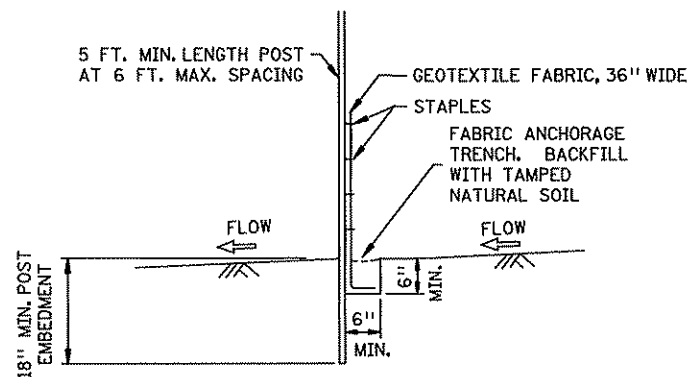

SILT FENCE, PREASSEMBLED  
DESIGN GUIDELINES:  
TO PROTECT AREAS FROM SHEET FLOW.  
MAXIMUM CONTRIBUTING AREA: 1 ACRE.

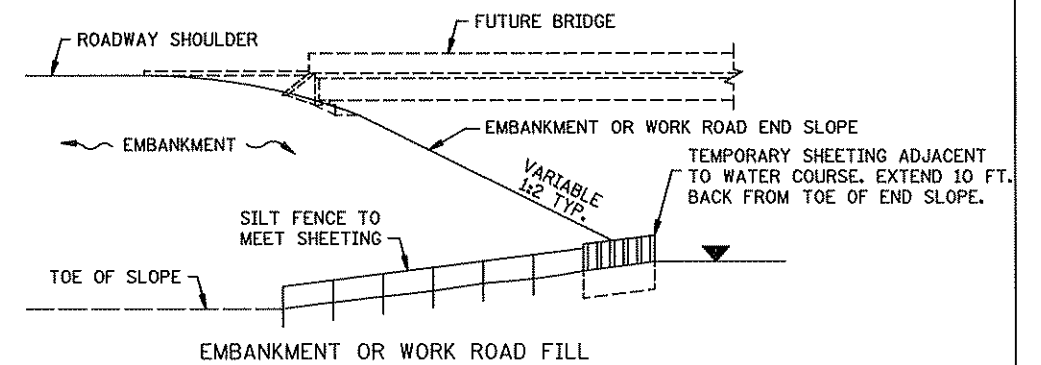

DESIGN GUIDELINES:  
WATER COURSE FLOW VELOCITY: 8 TO 15 FT./SEC.  
CONTRIBUTING SLOPE AREA: 3 ACRES  
SILT FENCE AT BRIDGE EMBANKMENT ADJACENT TO WATER

NOTES:

SEE SPECS. 2573, 3149 & 3886.

① COARSE FILTER AGGREGATE (SPEC. 3149) SHALL BE INCIDENTAL.

STANDARD SHEET NO. 5-297.408 (1 OF 2)	TITLE: TEMPORARY SEDIMENT CONTROL SILT FENCE
STANDARD APPROVED: SEPTEMBER 27, 2006	
STATE AID PROJECT NO. 02-614-37 SHEET NO. 36 OF 51 SHEETS	



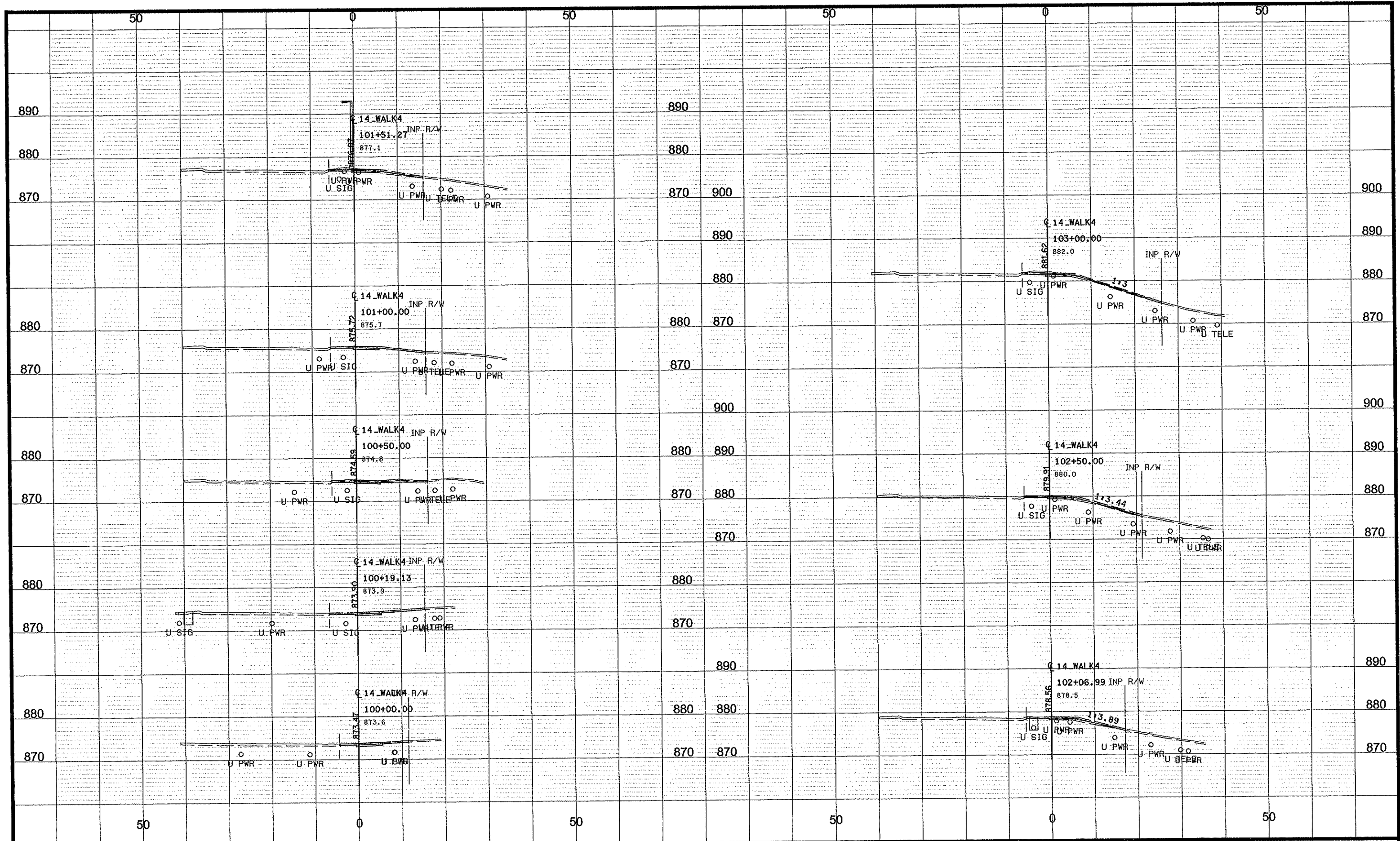

NO	DATE	BY	CHKD	APPR	REVISION
NAME: P:\14_PEDI\Plan\14_PED_XS4.dgn					
12/01/2010 2:15:39 PM					

DRAWN BY NJD DATE 9-22-10  
 DESIGN BY NJD DATE 9-22-10  
 CHECKED BY JEO DATE 11-29-10



**ANOKA COUNTY**  
**HIGHWAY DEPT.**

STATE AID PROJECT NO. 02-614-37  
 COON RAPIDS CITY NO. 06-48  
 MN STATE PROJECT NO. 114-020-40

**CROSS SECTIONS**  
 STA 100+00.00 TO 103+00.00  
 Sheet 37 of 51 Sheets

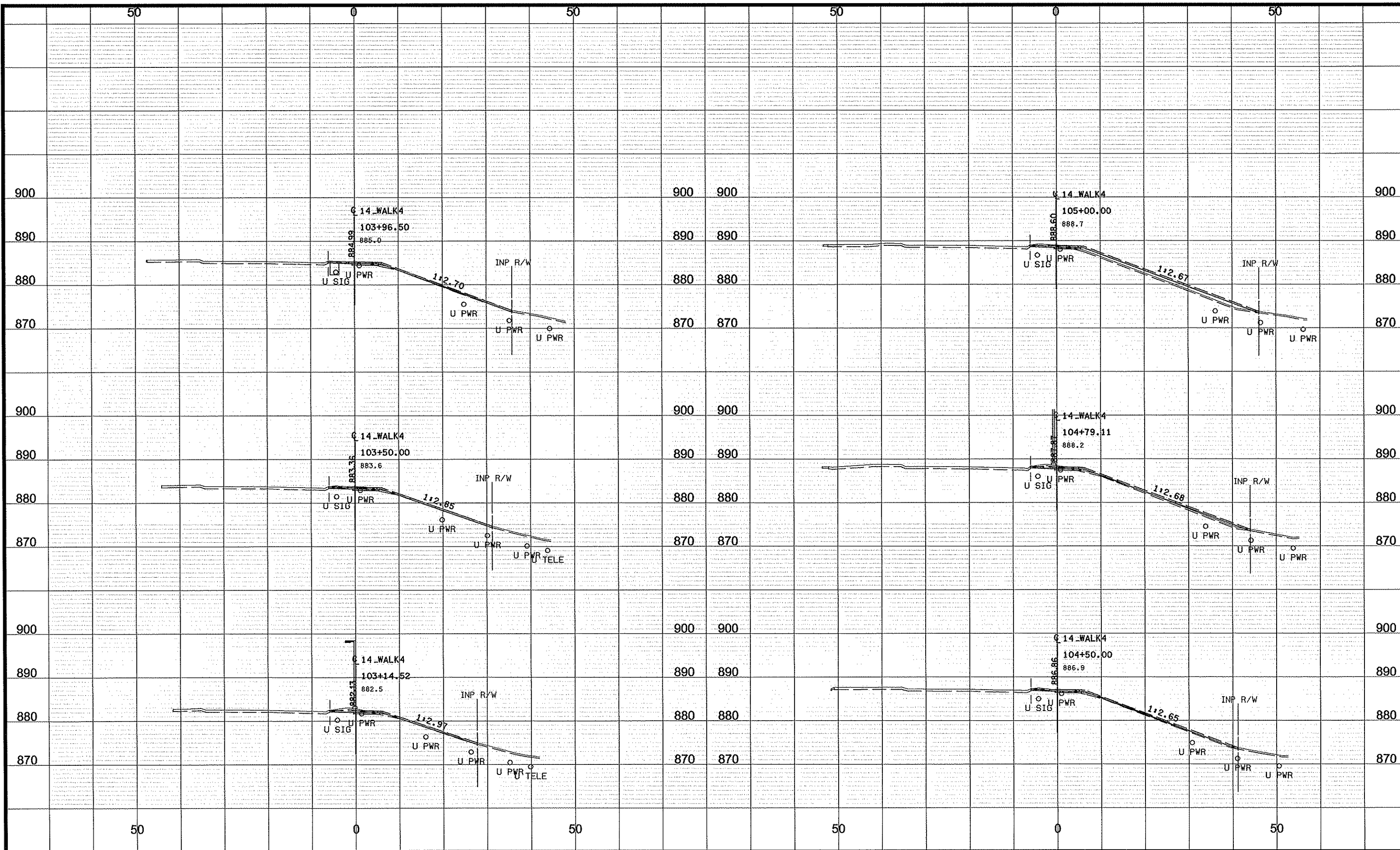

NO	DATE	BY	CKD	APPR	REVISION

NAME: P:\14\_PED\Plan14\_PED\_X84.dgn  
 12/01/2010 2:15:40 PM

DRAWN BY: NJD DATE: 9-22-10  
 DESIGN BY: NJD DATE: 9-22-10  
 CHECKED BY: JEO DATE: 11-29-10



ANOKA COUNTY  
 HIGHWAY DEPT.

STATE AID PROJECT NO. 02-614-37  
 COON RAPIDS CITY NO. 06-48  
 MN STATE PROJECT NO. 114-020-40

CROSS SECTIONS  
 STA 103+14.52 TO 105+00.00  
 Sheet 38 of 51 Sheets

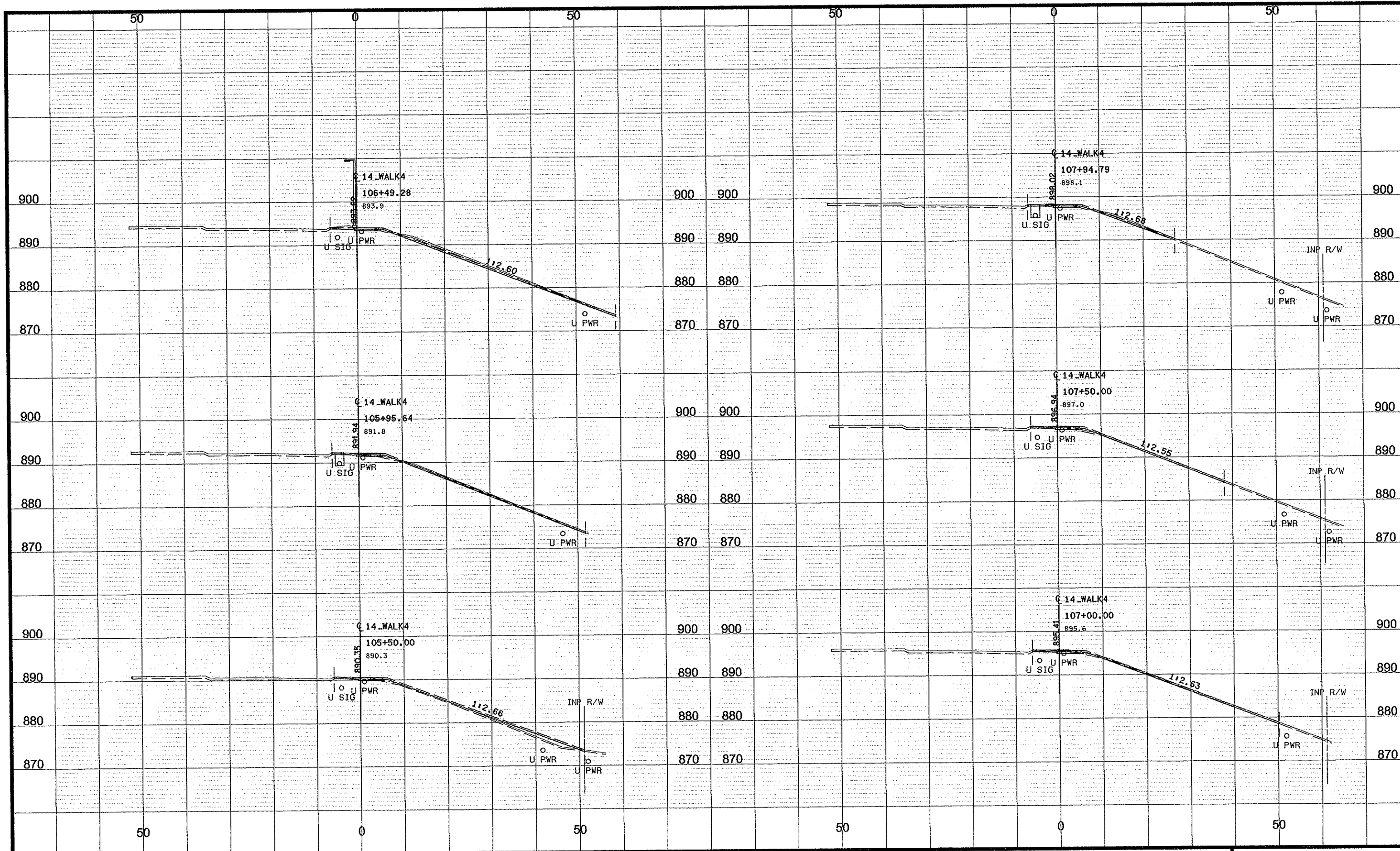

NO	DATE	BY	CHKD	APPR	REVISION
NAME: P:\14_PED\Plan\14_PED_XS4.dgn					

DRAWN BY	NJD	DATE	9-22-10
DESIGN BY	NJD	DATE	9-22-10
CHECKED BY	JEO	DATE	11-29-10

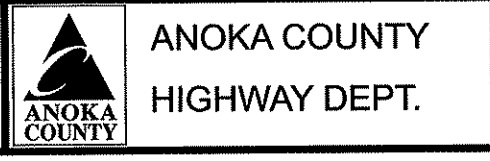

STATE AID PROJECT NO.	02-614-37
COON RAPIDS CITY NO.	06-48
MN STATE PROJECT NO.	114-020-40

CROSS SECTIONS	
STA	105+50.00 TO 104+94.79
Sheet	39 of 51 Sheets



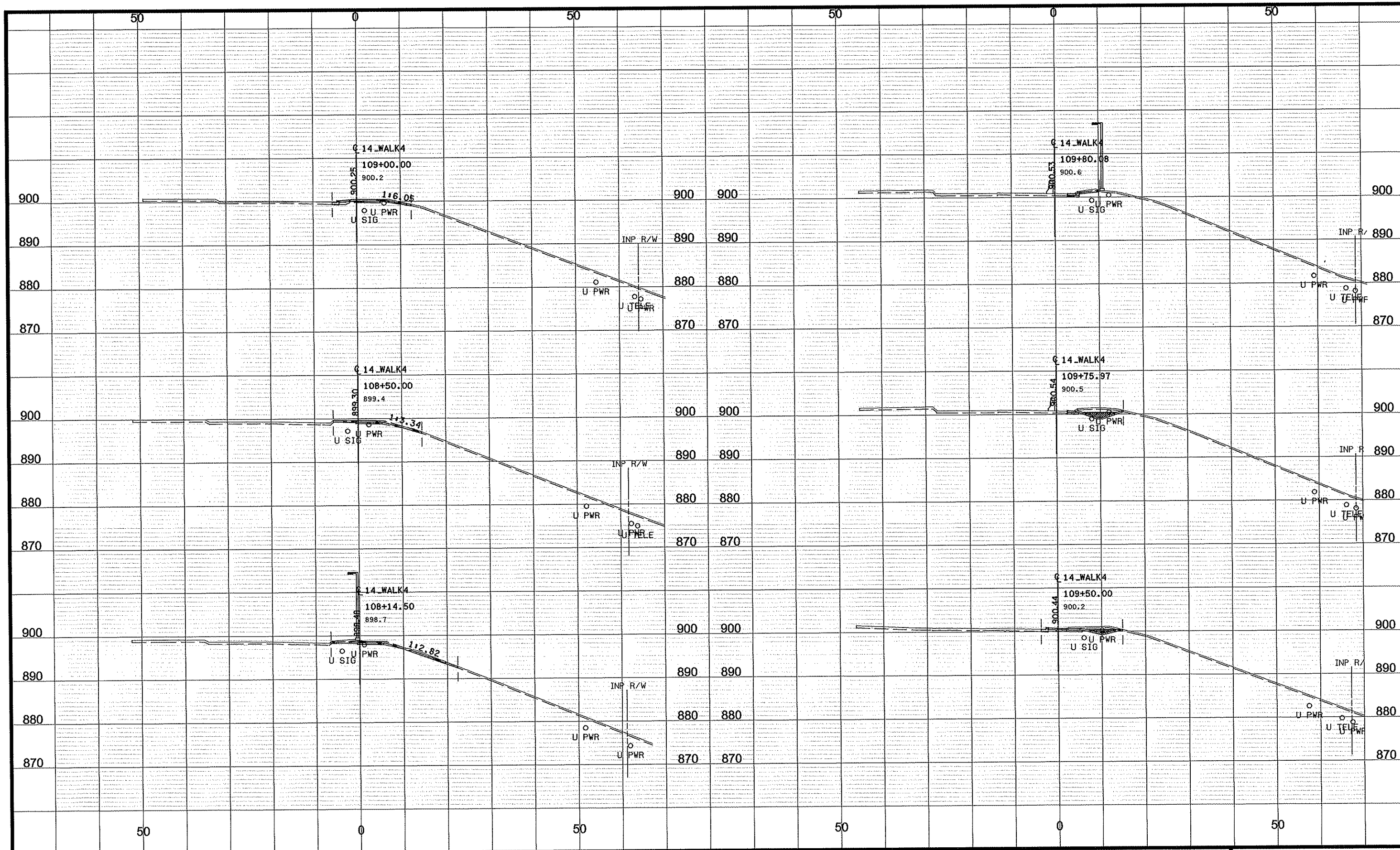

NO	DATE	BY	CKD	APPR	REVISION
NAME: P:\14_PEDI\Plan14_PED_XS4.dgn					
12/01/2010 2:15:43 PM					

DRAWN BY NJD DATE 9-22-10  
 DESIGN BY NJD DATE 9-22-10  
 CHECKED BY JEO DATE 11-29-10



STATE AID PROJECT NO. 02-614-37  
 COON RAPIDS CITY NO. 06-48  
 MN STATE PROJECT NO. 114-020-40

CROSS SECTIONS  
 STA 108+14.50 TO 109+80.08  
 Sheet 40 of 51 Sheets

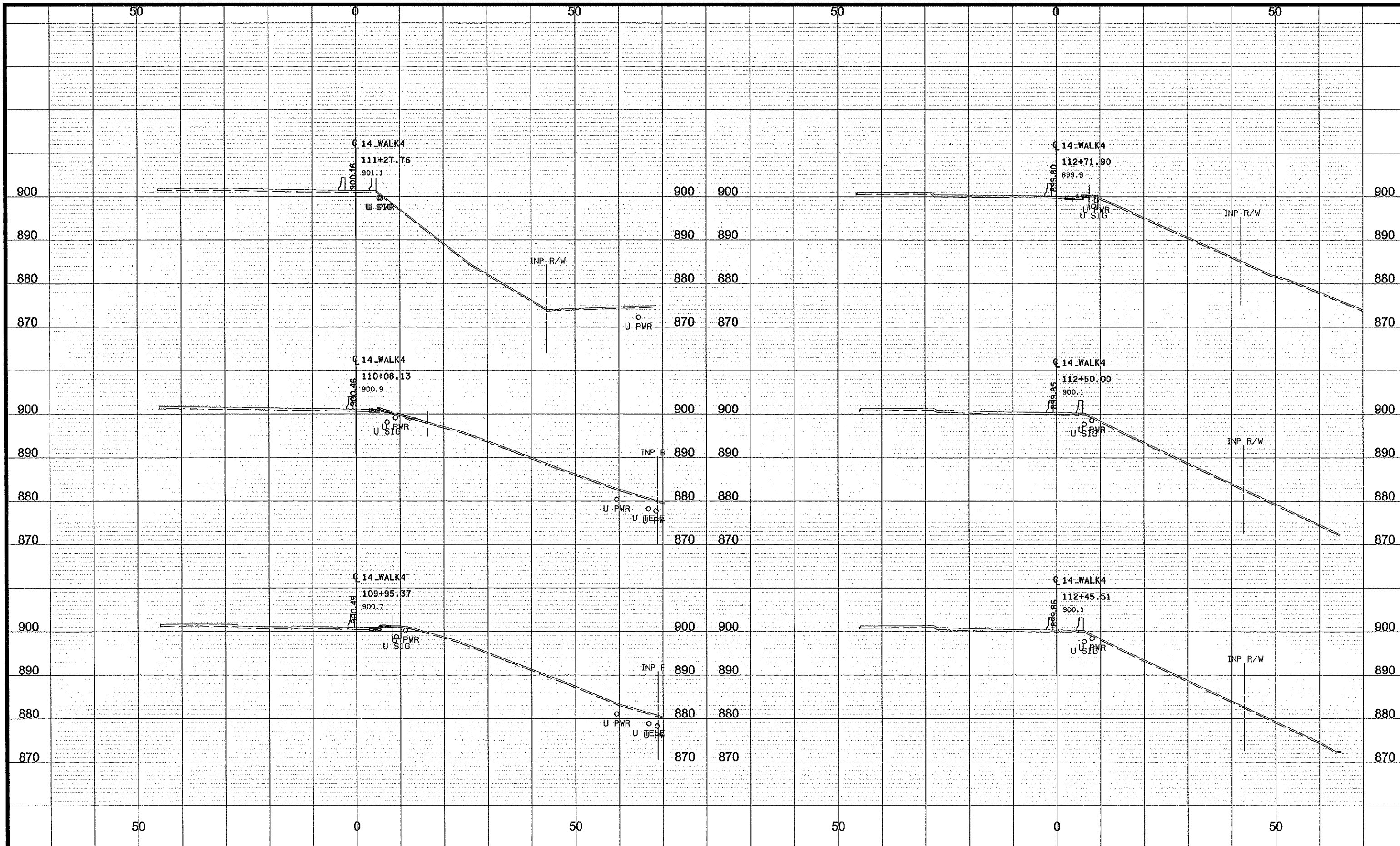

NO	DATE	BY	CKD	APPR	REVISION
NAME: P:14_PED\Plan14_PED_XS4.dgn					
12/01/2010 2:15:44 PM					

DRAWN BY NJD DATE 9-22-10  
 DESIGN BY NJD DATE 9-22-10  
 CHECKED BY JEO DATE 11-29-10



**ANOKA COUNTY**  
**HIGHWAY DEPT.**

STATE AID PROJECT NO. 02-614-37  
 COON RAPIDS CITY NO. 06-48  
 MN STATE PROJECT NO. 114-020-40

CROSS SECTIONS  
 STA 109+95.37 TO 112+71.90  
 Sheet 41 of 51 Sheets

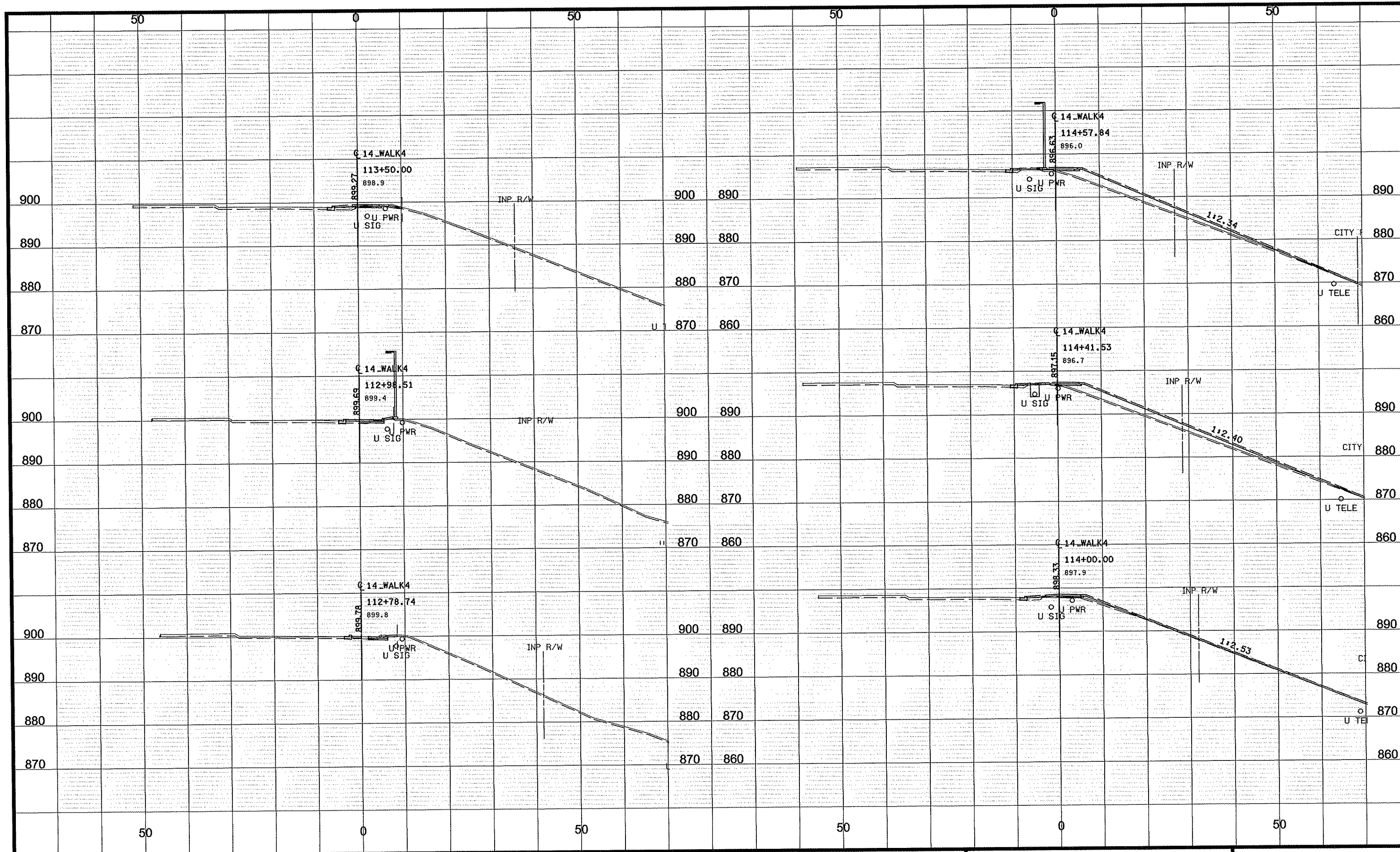

NO	DATE	BY	CHKD	APPR	REVISION
NAME: P:\14_PEDI\Plan\14_PED_X94.dgn					
12/01/2010 2:15:45 PM					

DRAWN BY NJD DATE 9-22-10  
 DESIGN BY NJD DATE 9-22-10  
 CHECKED BY JEO DATE 11-29-10



**ANOKA COUNTY**  
**HIGHWAY DEPT.**

STATE AID PROJECT NO. 02-614-37  
 COON RAPIDS CITY NO. 06-48  
 MN STATE PROJECT NO. 114-020-40

CROSS SECTIONS  
 STA 112+78.74 TO 114+57.84  
 Sheet 42 of 51 Sheets



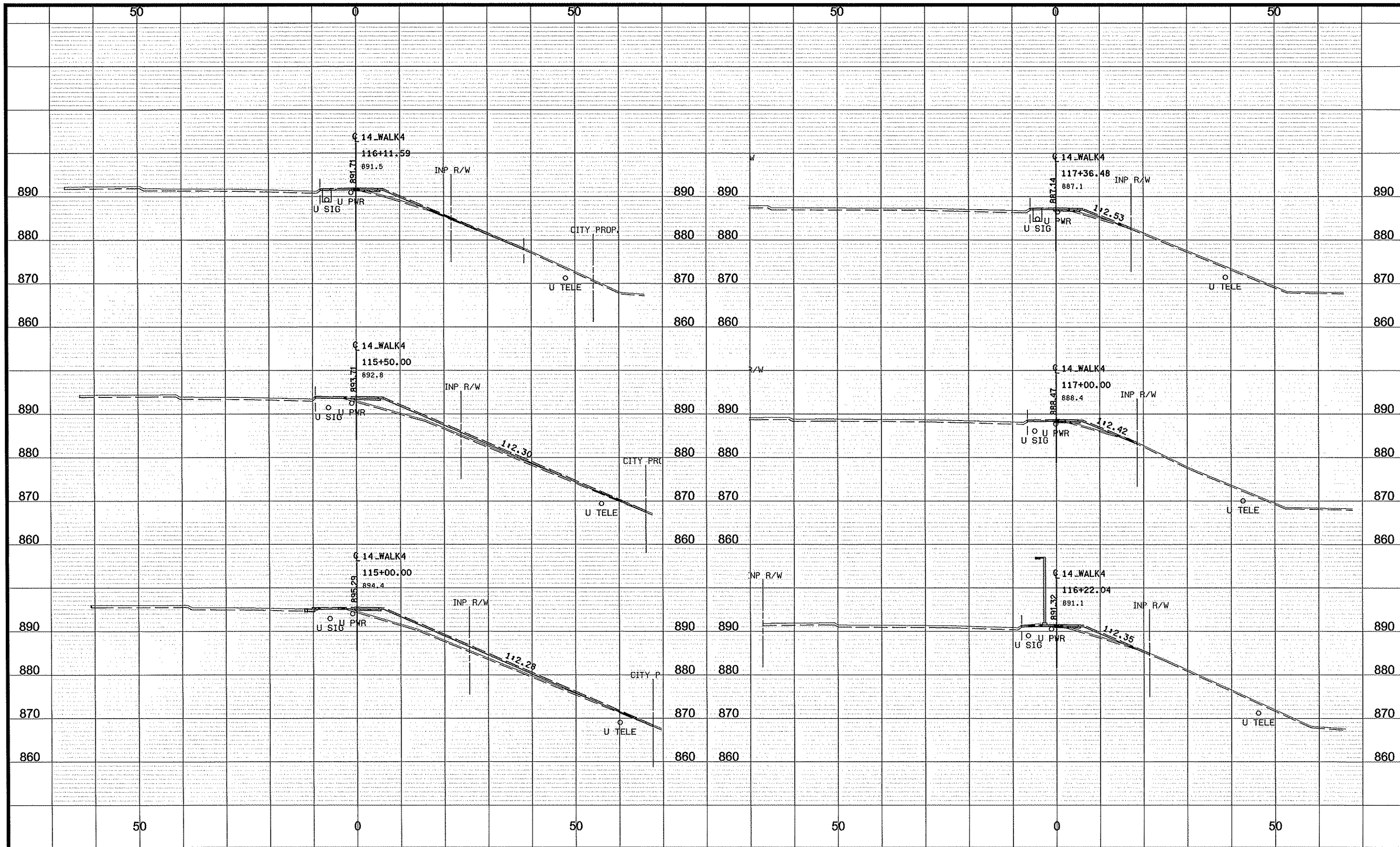

NO	DATE	BY	CKD	APPR	REVISION
NAME: P:\14_PED\Plan\14_PED_XS4.dgn					

DRAWN BY	NJD	DATE	9-22-10
DESIGN BY	NJD	DATE	9-22-10
CHECKED BY	JEO	DATE	11-29-10

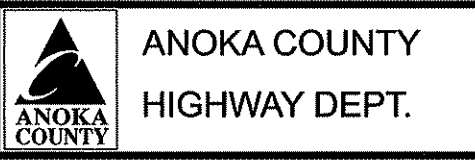

STATE AID PROJECT NO.	02-614-37
COON RAPIDS CITY NO.	06-48
MN STATE PROJECT NO.	114-020-40

CROSS SECTIONS  
 STA 115+00.00 TO 117+36.48  
 Sheet 43 of 51 Sheets

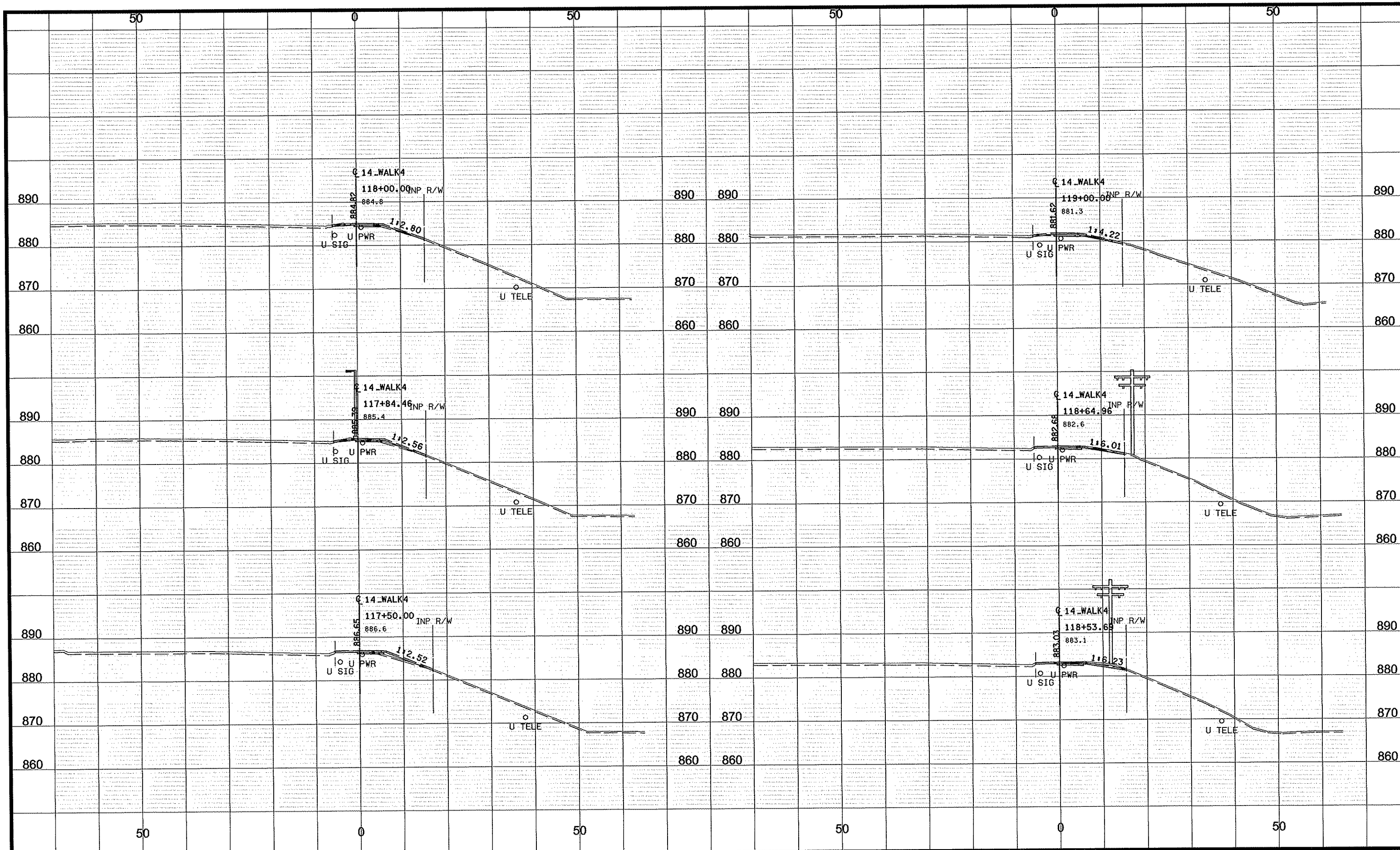

NO	DATE	BY	CHKD	APPR	REVISION

NAME: P:\14\_PED\Plan14\_PED\_XS4.dgn  
12/01/2010 2:16:46 PM

DRAWN BY NJD DATE 9-22-10  
 DESIGN BY NJD DATE 9-22-10  
 CHECKED BY JEO DATE 11-29-10

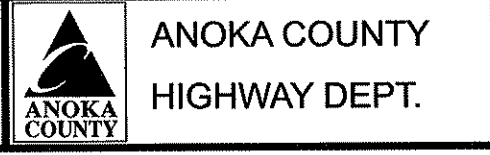

STATE AID PROJECT NO. 02-614-37  
 COON RAPIDS CITY NO. 06-48  
 MN STATE PROJECT NO. 114-020-40

CROSS SECTIONS  
 STA 117+50.00 TO 119+00.00  
 Sheet 44 of 51 Sheets

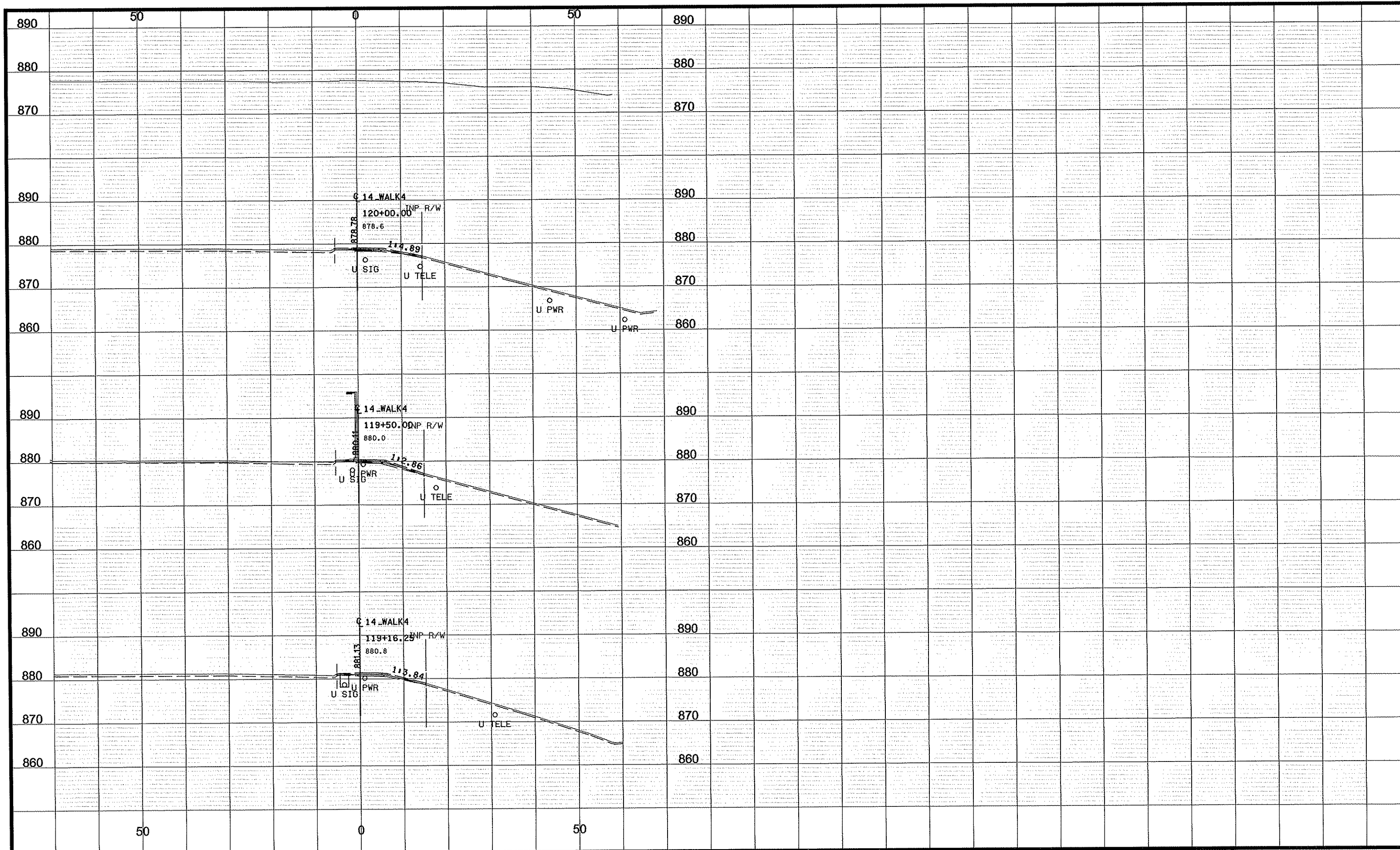

NO	DATE	BY	CKD	APPR	REVISION
					2:15:47 PM

NAME: P:\114\_PED\Plan\14\_PED\_XS4.dgn

NO	DATE	BY	CKD	APPR	REVISION
					2:15:47 PM

DRAWN BY NJD DATE 9-22-10  
 DESIGN BY NJD DATE 9-22-10  
 CHECKED BY JEO DATE 11-29-10

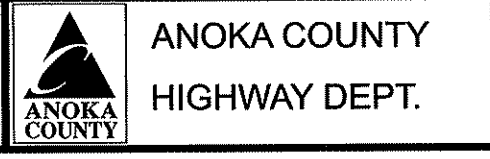

STATE AID PROJECT NO. 02-614-37  
 COON RAPIDS CITY NO. 06-48  
 MN STATE PROJECT NO. 114-020-40

CROSS SECTIONS  
 STA 119+16.25 TO 120+00.00  
 Sheet 45 of 51 Sheets

**RATING DATA**

A.A.S.H.T.O. MANUAL FOR BRIDGE EVALUATION, FIRST ED. WITH 2010 INTERIM REVISIONS.

ALTERNATE LFD METHOD

PROPOSED BRIDGE RATING:  
INVENTORY RATING HS24.6  
OPERATING RATING HS41.1

**LIST OF SHEETS**

1	GENERAL PLAN & ELEVATION
2	MODIFICATION PLAN
3	CONCRETE BARRIER (TYPE F, TL-5)
4	EXPANSION JOINT MODIFICATION DETAILS
5	WIRE FENCE DESIGN W-1 DETAILS
6	CONCRETE RAILING SLIPFORM ALTERNATE

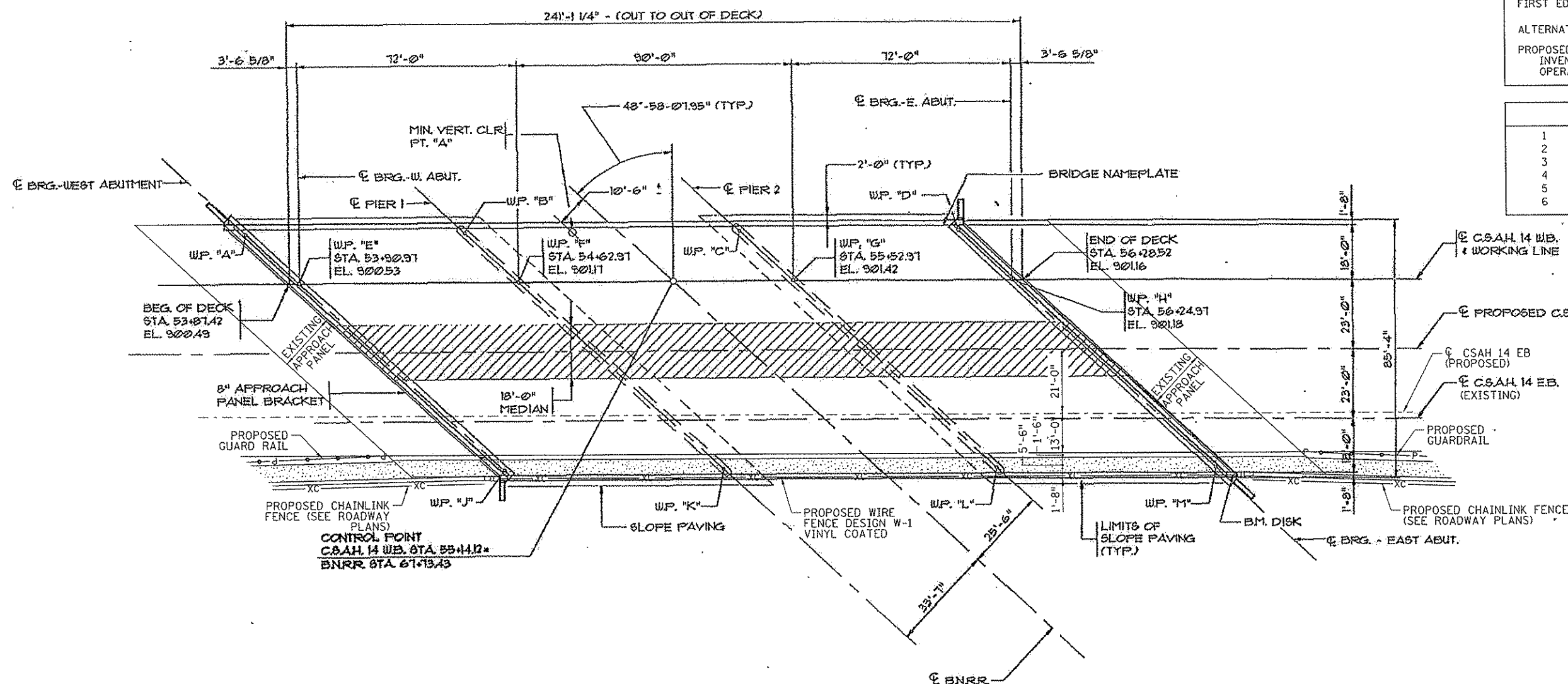

**PLAN**

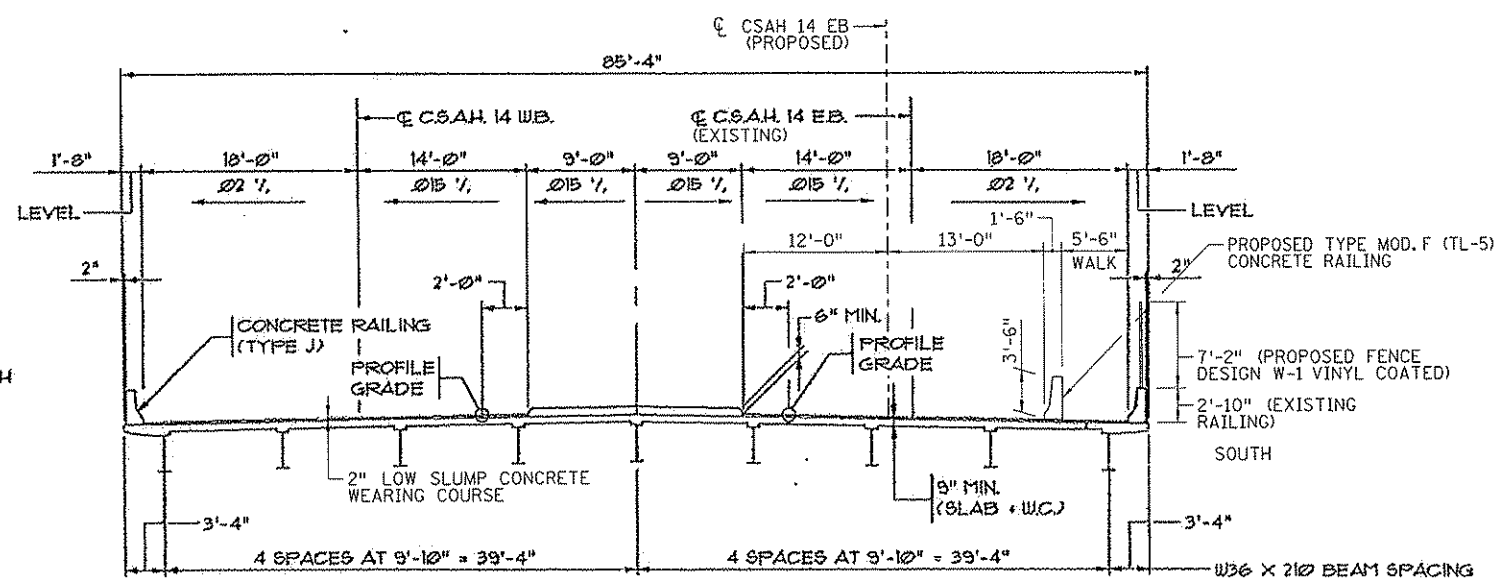

**TRANSVERSE SECTION THRU DECK**  
SCALE: 1/8" = 1'-0"

**WORK TO BE COMPLETED UNDER THIS CONTRACT**

1. INSTALL PROPOSED CONCRETE RAILING (TYPE F)
2. INSTALL PROPOSED CHAIN LINK FENCE ON EXISTING BARRIER.
3. INSTALL PROPOSED SIDEWALK COVER PLATES.
4. SAWCUT APPROACH PANEL AS NECESSARY FOR GUARDRAIL INSTALLATION.
5. CONSTRUCT PROPOSED SIDEWALK, GUARDRAIL AND FENCE PER ROADWAY PLANS.

I HEREBY CERTIFY THAT THIS PLAN WAS PREPARED BY ME OR UNDER MY DIRECT SUPERVISION AND THAT I AM A DULY LICENSED PROFESSIONAL ENGINEER UNDER THE LAWS OF THE STATE OF MINNESOTA.

Print Name: JAMISON BEISSWENGER

Signature: *[Signature]*

Date: 12-14-10 License #: 44648

**SRF CONSULTING GROUP, INC.**

**ANOKA COUNTY**

**BRIDGE NO. 02560**

CSAH 14 OVER BNSF RAILWAY  
SIDEWALK MODIFICATIONS  
0.20 MI WEST OF ROUND LAKE BLVD  
BRIDGE I.D. NO. 401

SEC. 5 & 6, T31N, R24W,  
ANOKA COUNTY

APPROVED: *[Signature]* 12/23/10  
STATE BRIDGE ENGINEER DATE

10:09:36 AM 12/14/2010 ... \BRNF In\PI\an\7248.dgn

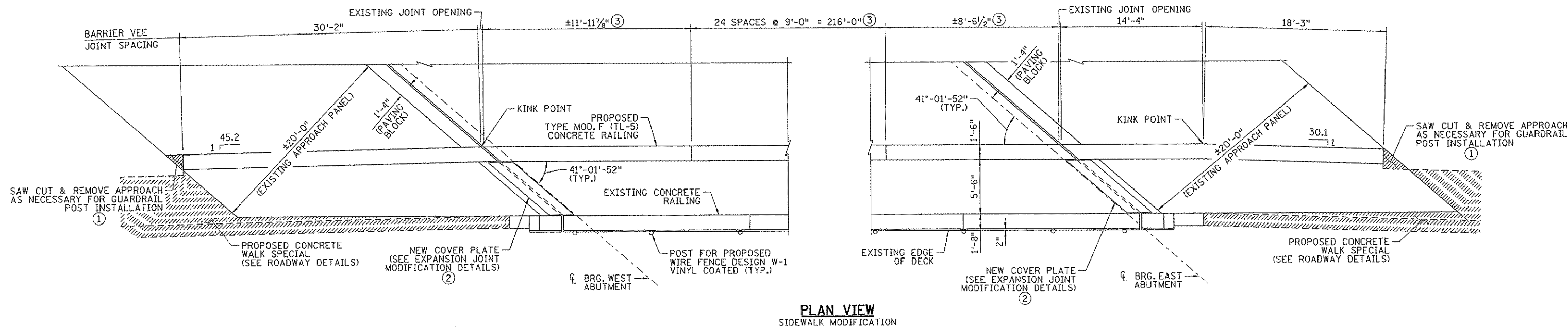

PLAN VIEW  
SIDEWALK MODIFICATION

**NOTES:**

- ① PAID FOR UNDER ITEM 2433.618 "RECONSTRUCT APPROACH PANEL".
- ② PAID FOR UNDER ITEM 2433.602 "RECONSTRUCT EXPANSION JOINT END".
- ③ CONTRACTOR SHALL ADJUST DIMENSIONS AS REQUIRED TO LINE UP VEE JOINTS WITH EXISTING DECK SAWCUT OVER PIERS.

**SCHEDULE OF QUANTITIES  
FOR BRIDGE NO. 02560 SIDEWALK MODIFICATIONS**

ITEM NO.	ITEM	UNIT	QUANTITY
2401.513	TYPE MOD F (TL-5) RAILING CONCRETE (3Y46)	LIN. FT.	300 (P)
2401.541	REINFORCEMENT BARS (EPOXY COATED)	POUND	8630 (P)
2433.516	ANCHORAGES TYPE REINF BARS	EACH	790 (P)
2433.602	RECONSTRUCT EXPANSION JOINT END	EACH	2 (P)
2433.618	RECONSTRUCT APPROACH PANEL	SQ. FT.	5
2557.501	WIRE FENCE DESIGN W-1 VINYL COATED	LIN. FT.	245 (P)

11/17/12 AM 12/14/2010 ... \BRV\Final\Plan\02560\_SideWalk\02560\_SideWalk.dgn

NO	DATE	BY	CHKD	APPR	REVISION

I hereby certify that this plan, specification, or report was prepared by me or under my direct supervision and that I am a duly Licensed Professional Engineer under the laws of the State of Minnesota.  
 Print Name: JAMISON BEISSWENGER  
  
 Date: 12-14-10 License #: 44648

BRIDGE NO. 02560  
 DRAWN BY E. JOHNSON  
 DESIGNED BY J. BEISSWENGER  
 CHECKED BY L. ERICKSON  
 COMM. NO. 7248



ANOKA COUNTY  
 SIDEWALK MODIFICATION PLAN  
 CSAH 14 BRIDGE OVER BNSF-SIDEWALK MOD.

SHEET 2 OF 6



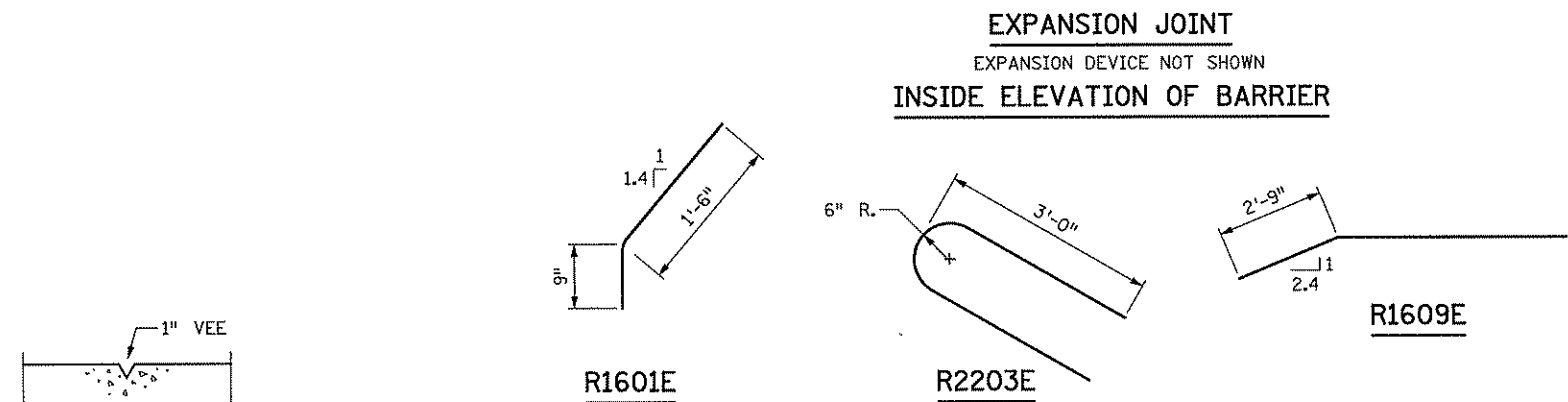
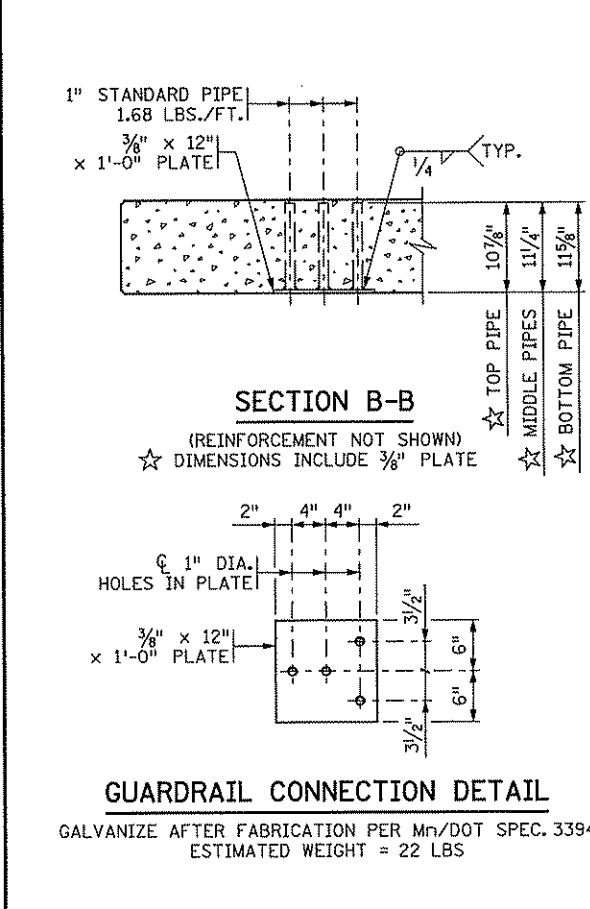
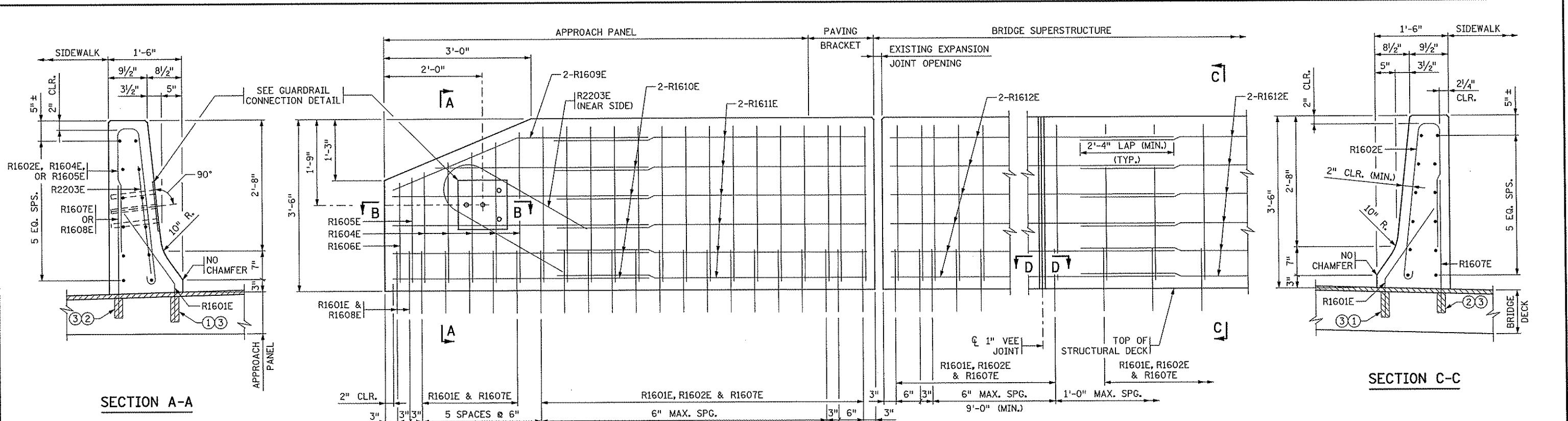

- GENERAL NOTES**
- LENGTH OF "TYPE F (TL-5) RAILING CONCRETE (3Y46)" FOR PAYMENT SHALL BE MEASURED BETWEEN THE OUTSIDE FACES OF THE CONCRETE BARRIER.
  - ALL REINFORCEMENT SHALL BE EPOXY COATED PER Mn/DOT 3301.
  - THE FIRST TWO NUMBERS AFTER THE R IN EACH BAR MARK DESIGNATE THE NOMINAL METRIC SIZE OF THE BAR.
  - CONCRETE BARRIER = 545 LBS./FT. (0.134 CU. YDS./FT.)
  - FINISH ALL EDGES OF BARRIER WITH 1/2" VEE, EXCEPT WHERE OTHERWISE NOTED.
  - MAXIMUM SPACING OF 1" VEE JOINTS SHALL BE 12'-0".
  - GUARDRAIL CONNECTION TO BE STRUCTURAL STEEL, Mn/DOT SPEC. 3306.
  - GUARDRAIL CONNECTION TO BE CONSIDERED INCIDENTAL TO "TYPE F (TL-5) RAILING CONCRETE (3Y46)".
  - ① EMBED BAR R1601E 7" WITH AN APPROVED EPOXY ADHESIVE. ULTIMATE PULL-OUT STRENGTH = 31,000 POUNDS. PROOF LOAD BARS TO 15,000 POUNDS.
  - ② EMBED BARS R1607E AND R1608E 5" WITH AN APPROVED EPOXY ADHESIVE. ULTIMATE PULL-OUT STRENGTH = 5,000 POUNDS. NO PROOF LOAD TESTING REQUIRED.
  - ③ ALL COSTS ASSOCIATED WITH DRILLING AND INSTALLING THE ANCHORAGES FOR BARS R1601E, R1607E & R1608E SHALL BE PAID FOR UNDER ITEM 2433.516 "ANCHORAGES TYPE REINF BARS".

**BILL OF REINFORCEMENT FOR BARRIER**

BAR	NO.	LENGTH	SHAPE	LOCATION
R1601E	395	2'-3"	—	BARRIER DOWEL
R1602E	381	6'-3"	—	BARRIER VERTICAL
R2203E	2	6'-6"	—	GUARD RAIL
R1604E	2 SER. OF 5	5'-3" TO 6'-1"	—	BARRIER VERTICAL
R1605E	2	5'-2"	—	BARRIER VERTICAL
R1606E	2	5'-1"	—	BARRIER VERTICAL
R1607E	391	2'-11"	—	BARRIER DOWEL
R1608E	4	2'-9"	—	BARRIER DOWEL
R1609E	4	6'-6"	—	BARRIER LONGIT.
R1610E	20	6'-3"	—	BARRIER LONGIT.
R1611E	24	27'-3"	—	BARRIER LONGIT.
R1612E	60	50'-0"	—	BARRIER LONGIT.

REVISED: 05-26-2006  
APPROVED: JULY 25, 2005  
STATE BRIDGE ENGINEER

BARRIER RUSTICATION

R1602E, R1604E, R1605E & R1606E

MODIFIED  
FIG. 5-397.126

NO.	DATE	BY	CHKD	APPR	REVISION

I hereby certify that this plan, specification, or report was prepared by me or under my direct supervision and that I am a duly Licensed Professional Engineer under the laws of the State of Minnesota.  
Print Name: JAMISON BEISSWENGER  
Date: 12-14-10 License #: 44648

BRIDGE NO. 02560

DRAWN BY E. JOHNSON  
DESIGNED BY J. BEISSWENGER  
CHECKED BY L. ERICKSON  
COMM. NO. 7248

**SRF CONSULTING GROUP, INC.**

ANOKA COUNTY  
CONCRETE BARRIER (TYPE F, TL-5)  
CSAH 14 BRIDGE OVER BNSF-SIDEWALK MOD.

SHEET 3 OF 6



1" DIA. x 6" LONG SLOTTED HOLE FOR 3/4" DIA. x 1/2" FLAT HEAD CAP SCREW WITH 2" LONG HEX COUPLING NUT AND 3/4" DIA. x 4" BOLT. DO NOT TIGHTEN DOWN CAP SCREW. SEE DETAIL "A"

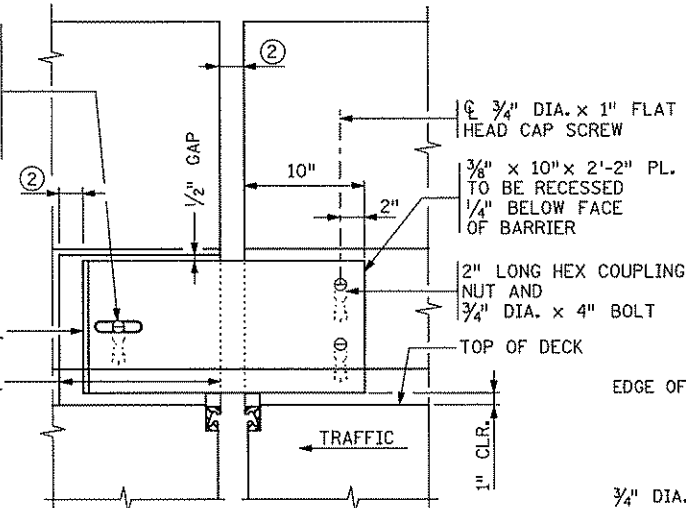

SECTION C-C

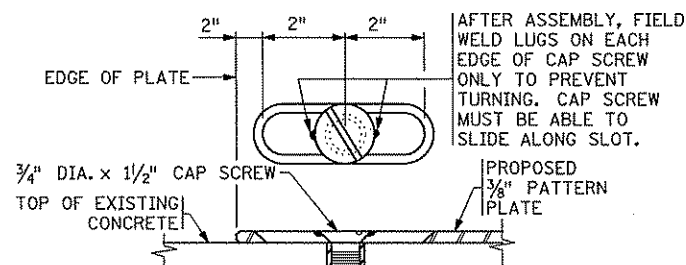

DETAIL "B"

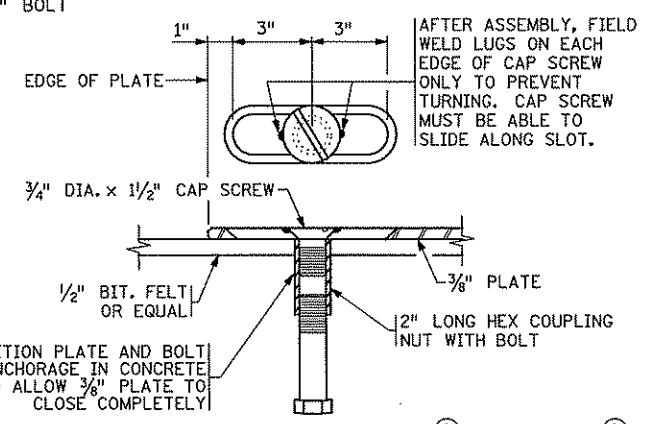

DETAIL "A"

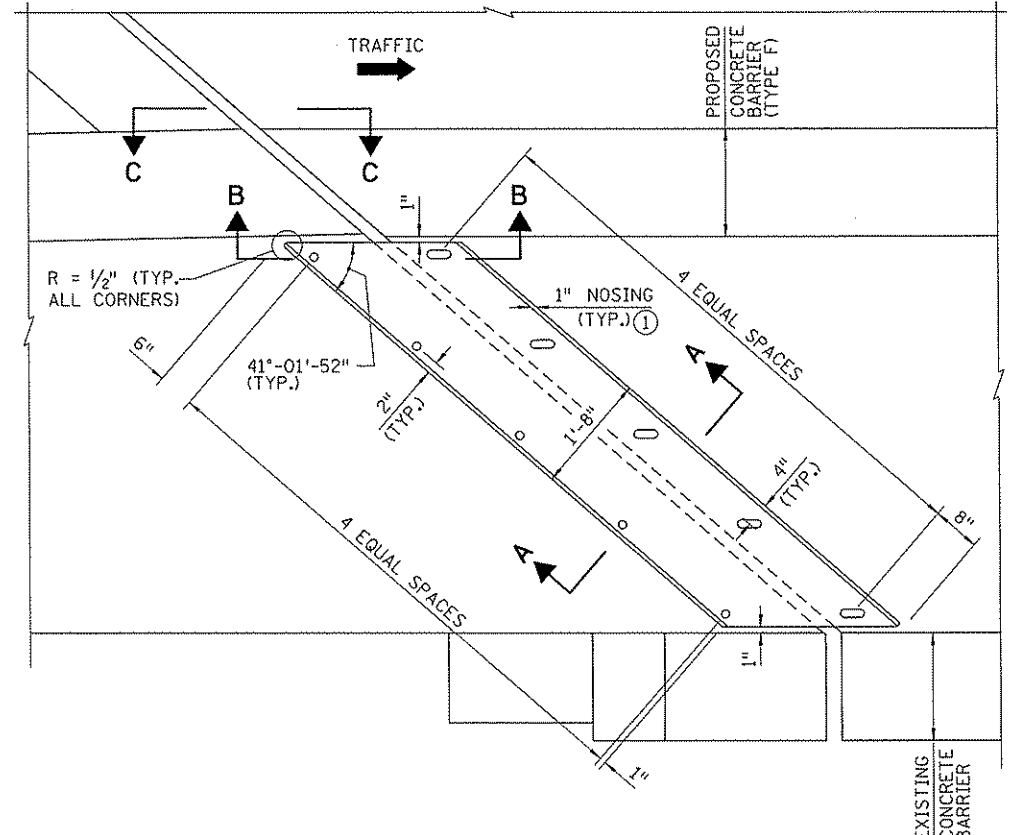

PLAN VIEW AT EXPANSION JOINT MODIFICATION

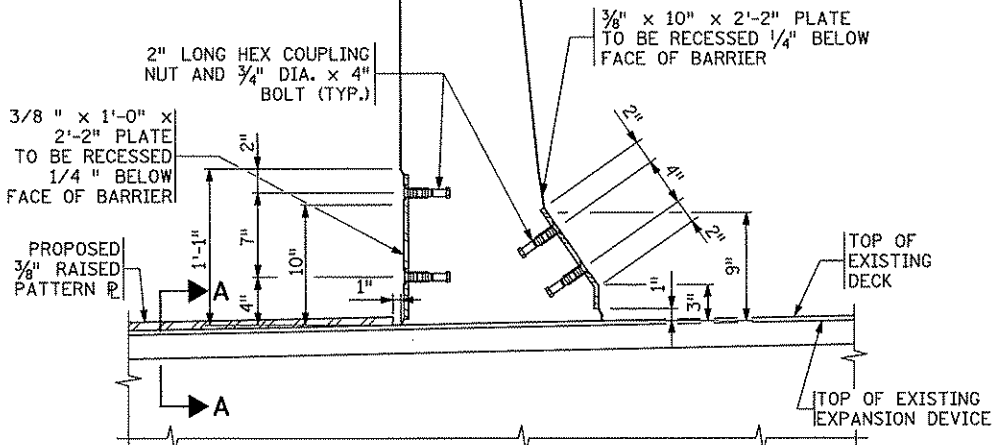

SECTION THROUGH PROPOSED TYPE F RAILING

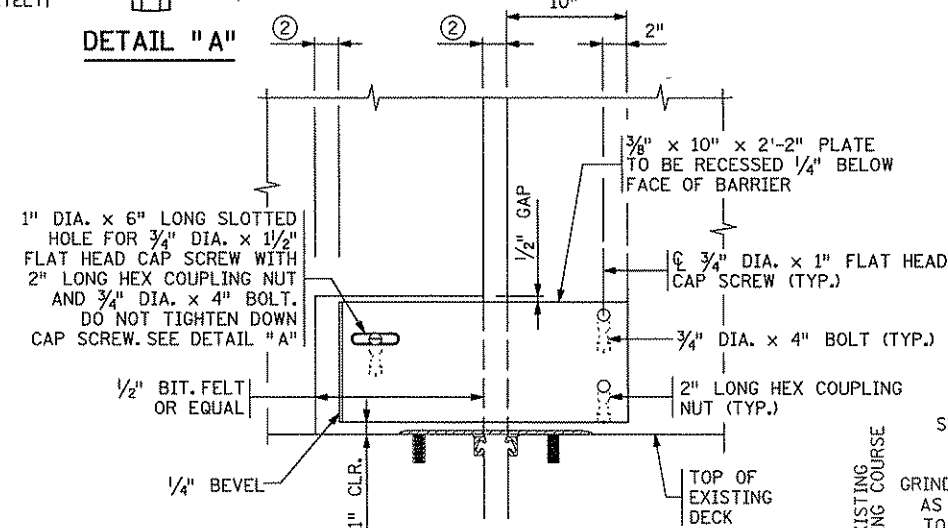

SECTION B-B

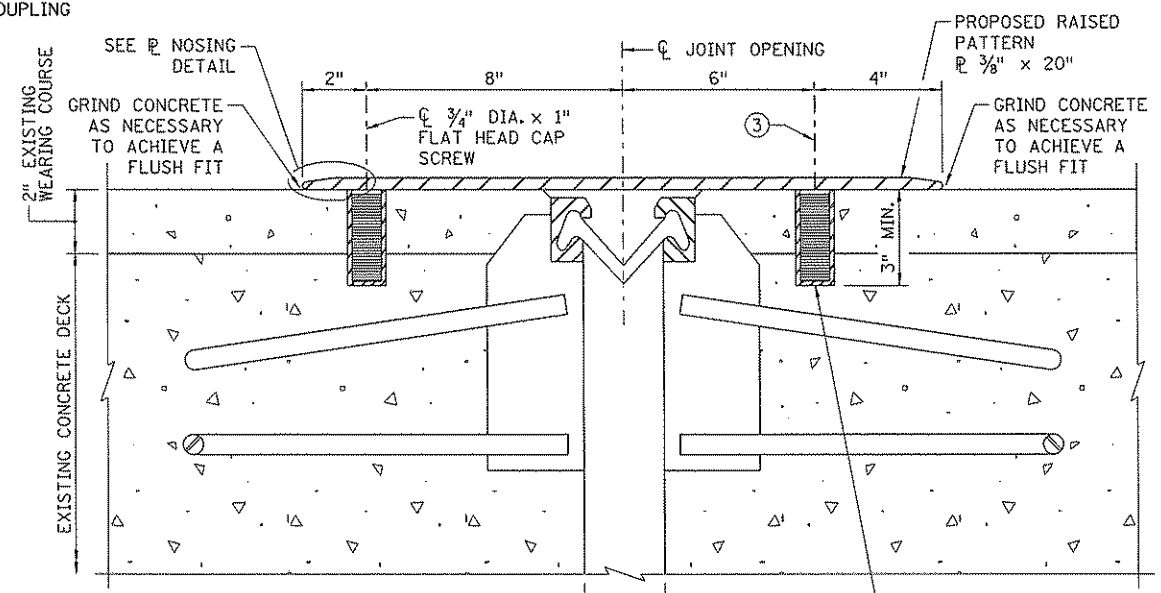

SECTION A-A

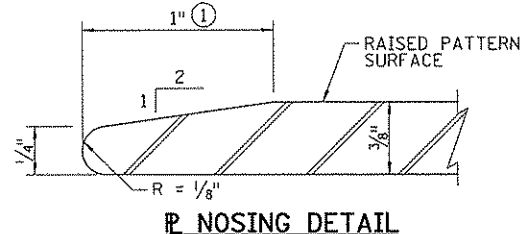

R NOSING DETAIL

**GENERAL NOTES**

- ALL WORK AND MATERIALS SHOWN ON THIS SHEET SHALL BE PAID FOR UNDER ITEM 2433.602 "RECONSTRUCT EXPANSION JOINT END".
- GALVANIZE STRUCTURAL STEEL AFTER FABRICATION AS PER Mn/DOT SPEC. 3394. GALVANIZE FASTENERS AS PER Mn/DOT SPEC. 3392.
- STRUCTURAL STEEL SHALL COMPLY WITH Mn/DOT SPEC. 3306 OR Mn/DOT SPEC. 3309.
- CAP SCREWS SHALL BE COUNTERSUNK 1/16" BELOW TOP OF PLATE.
- ① MEASURED PARALLEL TO WALK
- ② ±2" EXPANSION JOINT OPENING
- ③ 1" DIA. x 4" LONG SLOTTED HOLE FOR 3/4" DIA. x 1/2" FLAT HEAD CAP SCREW. DO NOT TIGHTEN DOWN CAP SCREW. SEE DETAIL "B".

I hereby certify that this plan, specification, or report was prepared by me or under my direct supervision and that I am a duly Licensed Professional Engineer under the laws of the State of Minnesota.  
 Print Name: JAMISON BEISSWENGER  
 Date: 12-14-10 License #: 44648

BRIDGE NO. 02560

DRAWN BY E. JOHNSON  
 DESIGNED BY J. BEISSWENGER  
 CHECKED BY L. ERICKSON  
 COMM. NO. 7248



ANOKA COUNTY  
 EXPANSION JOINT MODIFICATION DETAILS  
 CSAH 14 BRIDGE OVER BNSF-SIDEWALK MOD.

SHEET 4 OF 6

10:29:21 AM 12/14/2010 ... \BRV\Final\Plan\7248\_exp01.dgn

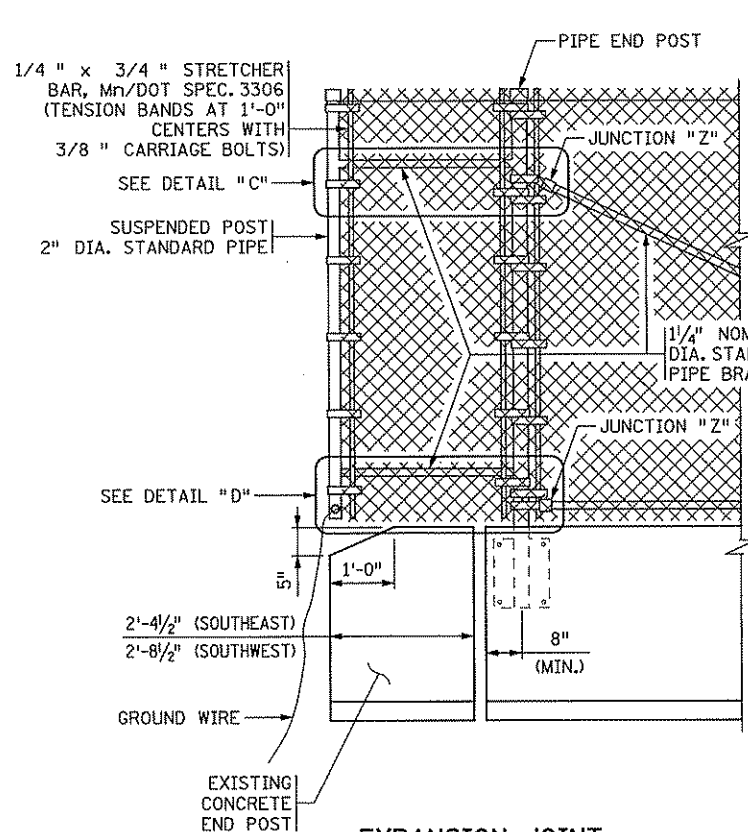

**EXPANSION JOINT**  
(EXPANSION DEVICE NOT SHOWN)

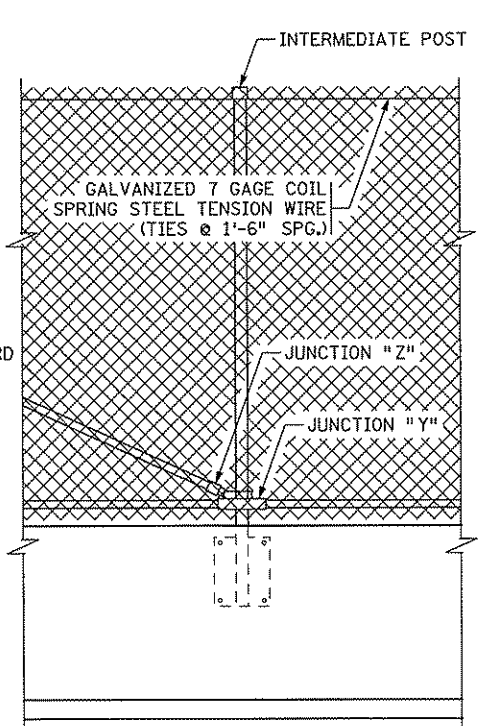

**INSIDE ELEVATION OF RAILING**

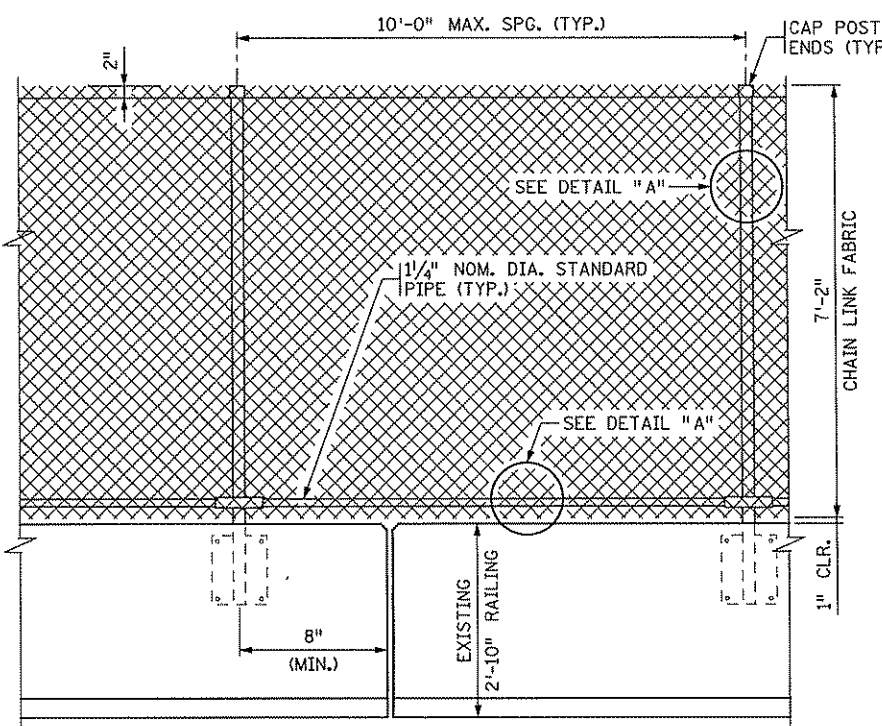

**DEFLECTION JOINT**

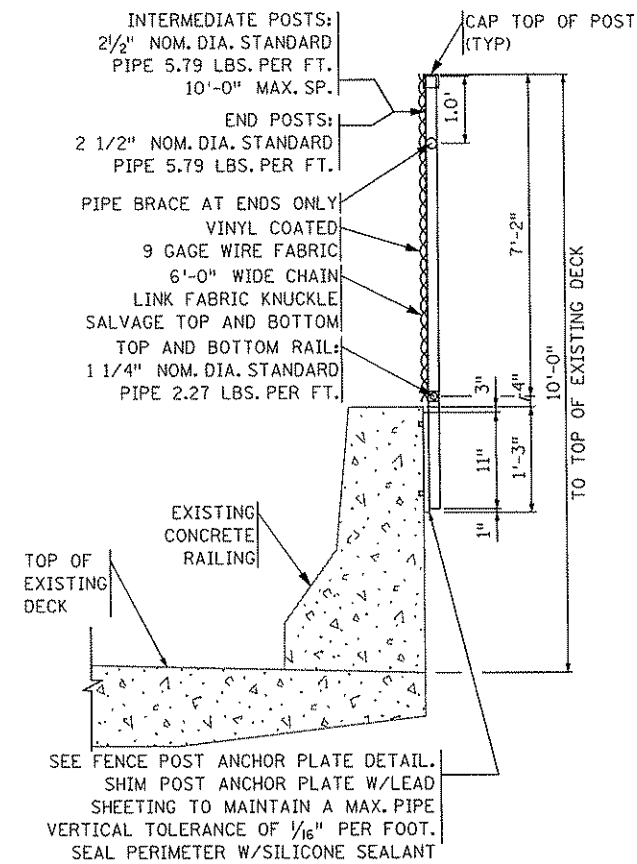

**TYPICAL SECTION THROUGH FENCE**  
INTERMEDIATE POST SHOWN

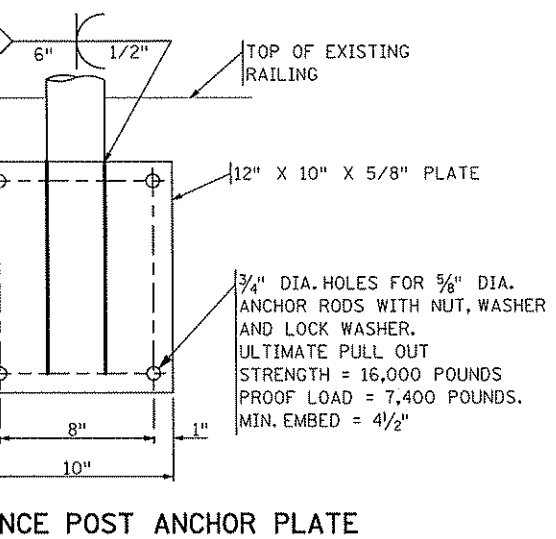
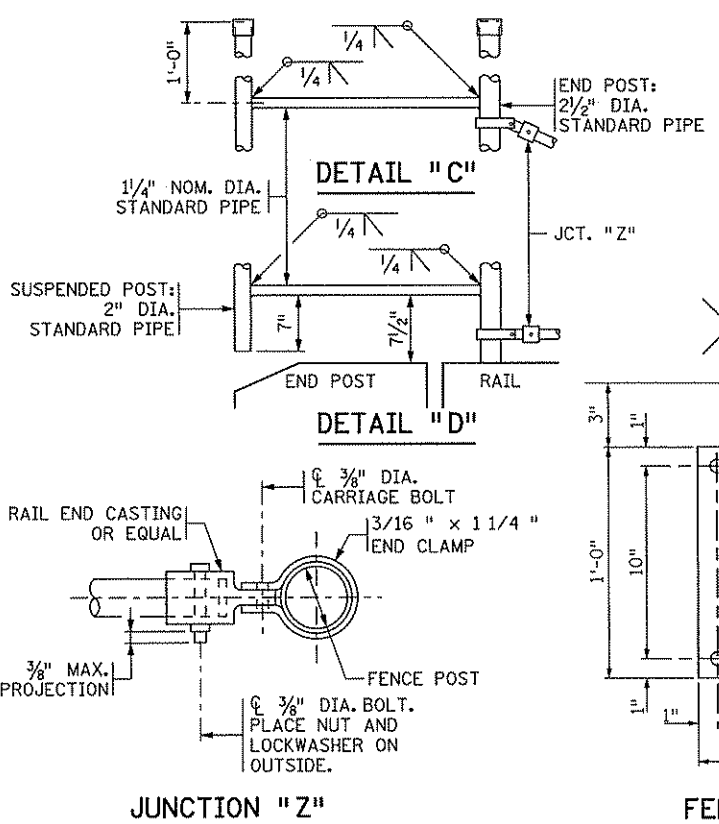
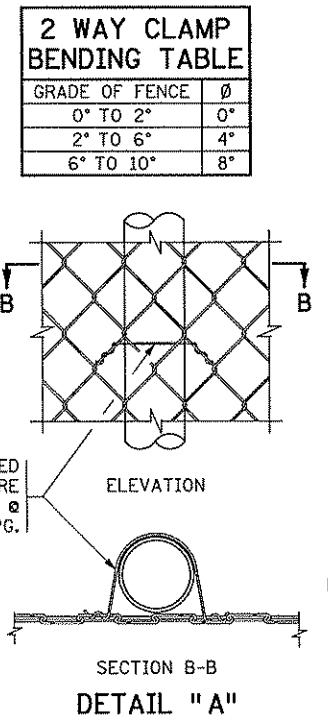
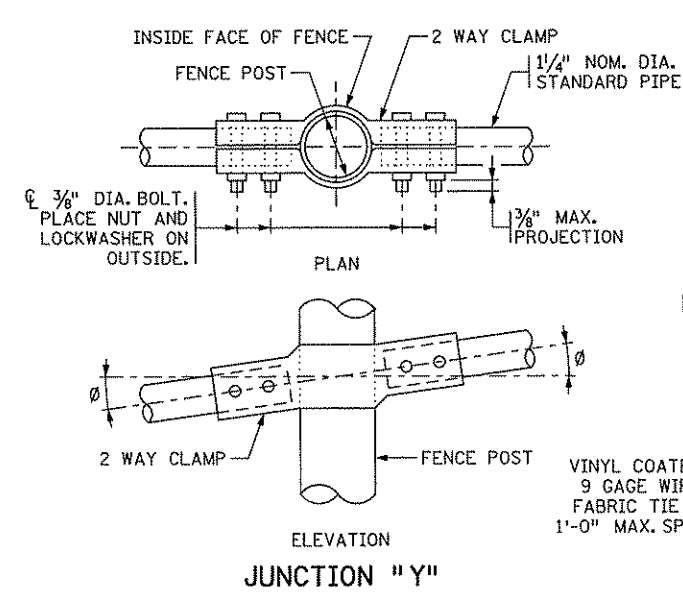

**GENERAL NOTES**

LENGTH OF "WIRE FENCE, DESIGN W-1" FOR PAYMENT SHALL BE MEASURED BETWEEN THE ENDS OF THE CONCRETE RAIL POSTS.

FENCE POSTS AND FENCE POST ANCHORAGES SHALL BE SET VERTICAL, UNLESS OTHERWISE NOTED.

C/L OF FENCE POST ANCHORAGE SHALL BE A MINIMUM OF 8" FROM JOINTS.

END POSTS AND BRACING SHALL BE AT 500 FT. MAXIMUM INTERVALS.

ALL POSTS SHALL HAVE A MEANS TO SECURELY HOLD THE TOP TENSION WIRE IN POSITION AND ALLOW FOR THE REMOVAL AND REPLACEMENT OF A POST WITHOUT DAMAGING THE TOP WIRE.

WIRE TIES MAY BE 9 GAGE GALVANIZED STEEL OR 0.179" MIN. ALUMINUM ALLOY CONFORMING TO A.S.T.M. B211, ALLOY 1100-H18. USE 12 1/2 GAGE GALVANIZED HOW RINGS FOR TENSION WIRE TIES.

ALL MATERIAL IN THE END POST IS INCLUDED IN THE WIRE FENCE DESIGN W-1 VINYL COATED QUANTITY.

SEE SPECIAL PROVISIONS FOR REQUIREMENTS NOT INCLUDED ON THIS SHEET AND FOR BASIS OF PAYMENT.

GROUNDING WIRE AND ROD INCIDENTAL TO "WIRE FENCE, DESIGN W-1".

FENCE SHALL BE GROUNDED WITH COPPER WIRE AT EACH END OF THE BRIDGE. ATTACH WIRE TO 5/8" COPPER ROD PER MN/DOT SPEC. 2557.3E.

ANCHORAGES SHALL BE PER MN/DOT SPEC. 3385, TYPE A.

GALVANIZE THE FENCE POST ANCHOR PLATE AFTER FABRICATION PER MN/DOT SPEC. 3394.

ALL HARDWARE SHALL BE GALVANIZED PER MN/DOT SPEC. 3392.

I hereby certify that this plan, specification, or report was prepared by me or under my direct supervision and that I am a duly Licensed Professional Engineer under the laws of the State of Minnesota.

Print Name: **JAMISON BEISSWENGER**

Date: **12-14-10** License #: **44648**

BRIDGE NO.  
**02560**

DRAWN BY  
**E. JOHNSON**  
DESIGNED BY  
**J. BEISSWENGER**  
CHECKED BY  
**L. ERICKSON**  
COMM. NO. **7248**



**ANOKA COUNTY**  
WIRE FENCE DESIGN W-1 DETAILS  
CSAH 14 BRIDGE OVER BNSF-SIDEWALK MOD.

SHEET  
**5**  
OF  
**6**

10:12:16 AM 12/14/2010 ...BR\Final\Plan\7248\_r103.dgn

NO	DATE	BY	CKD	APPR	REVISION

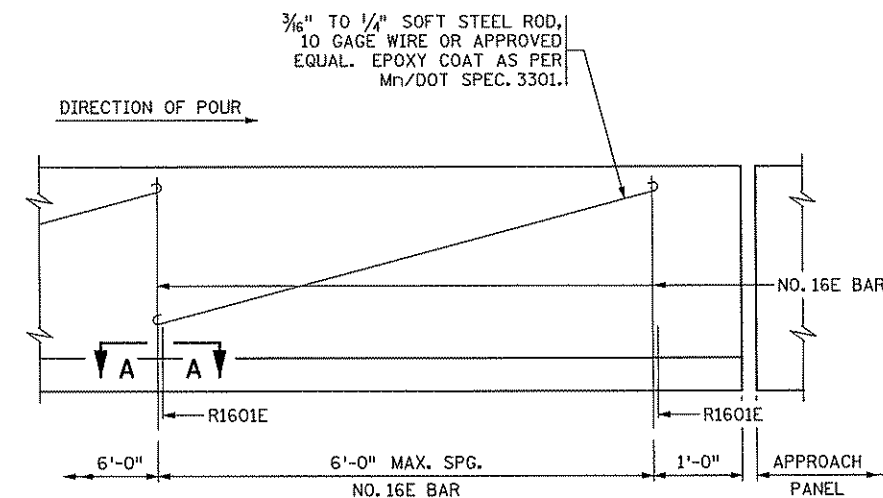

INSIDE ELEVATION OF RAILING

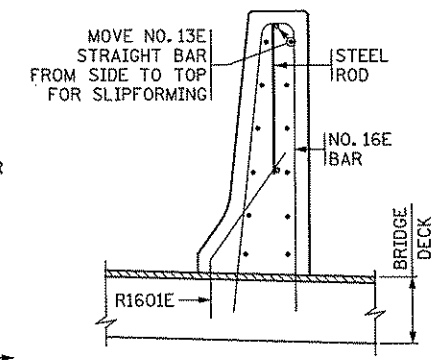

RAILING SECTION

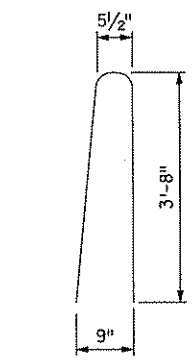

NO. 16E BAR  
DRILLED IN ALTERNATE

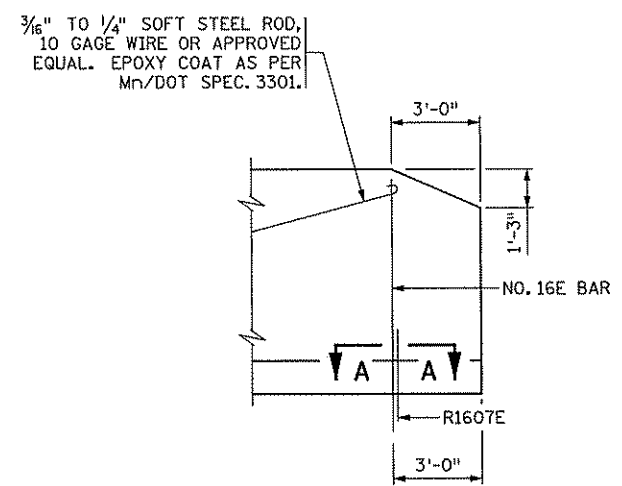

INSIDE ELEVATION OF RAILING  
AT END OF APPROACH PANEL

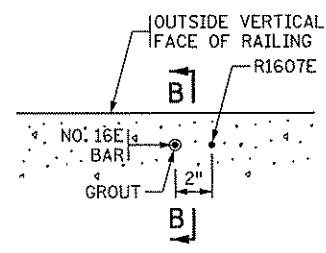

SECTION A-A

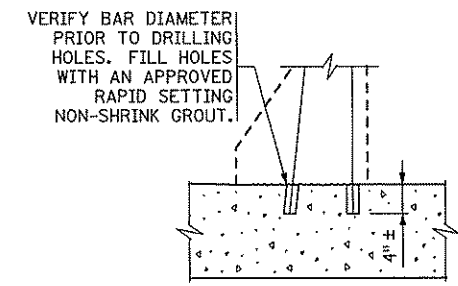

SECTION B-B

INSTALLATION DETAILS  
FOR NO. 16E (DRILLED IN ALTERNATE)

**NOTES:**  
 CONTRACTOR WILL TOOL V-GROOVE AT DEFLECTION JOINTS AT TIME RAIL IS CAST AND SHALL EXTEND V-GROOVE AROUND ENTIRE PERIMETER OF RAIL.  
 FOR ADDITIONAL DIMENSIONS, DETAILS, REINFORCEMENT AND NOTES SEE RAILING SHEET.  
 FORM RAIL FOR A MINIMUM OF 2' ON EACH SIDE OF EXPANSION DEVICES, LIGHT STANDARDS AND DECK DRAIN BOX OUTS.  
 PAY QUANTITIES WILL NOT BE ADJUSTED AS A RESULT OF SELECTING THIS ALTERNATE.  
 USE A SIMILAR METHOD FOR TALLER RAILINGS OR MODIFIED VERSIONS OF THIS RAILING.

APPROVED: NOVEMBER 22, 2002

*Daniel J. Johnson*  
 STATE BRIDGE ENGINEER

STATE OF MINNESOTA  
 DEPARTMENT OF TRANSPORTATION

CONCRETE RAILING (TYPE F)  
 (SLIPFORM ALTERNATE)

REVISION      DETAIL NO.

B830

10:13:04 AM 12/14/2010 ... \BR\F Ina\Plan\7248\_det01.dgn

NO	DATE	BY	CKD	APPR	REVISION

I hereby certify that this plan, specification, or report was prepared by me or under my direct supervision and that I am a duly Licensed Professional Engineer under the laws of the State of Minnesota.  
 Print Name: JAMISON BEISSWENGER  
*Jamison Beisswenger*  
 Date 12-14-10 License # 44648

BRIDGE NO.  
 02560

DRAWN BY  
 E. JOHNSON  
 DESIGNED BY  
 J. BEISSWENGER  
 CHECKED BY  
 L. ERICKSON  
 COMM. NO. 7248



ANOKA COUNTY  
 B-DETAILS  
 CSAH 14 BRIDGE OVER BNSF-SIDEWALK MOD.

SHEET  
 6  
 OF  
 6