

GOVERNING SPECIFICATIONS

THE 2018 EDITION OF THE MINNESOTA DEPARTMENT OF TRANSPORTATION "STANDARD SPECIFICATIONS FOR CONSTRUCTION" SHALL GOVERN.

ALL TRAFFIC CONTROL DEVICES SHALL CONFORM TO THE LATEST EDITION OF THE MINNESOTA MANUAL ON UNIFORM TRAFFIC CONTROL DEVICES, INCLUDING THE LATEST FIELD MANUAL FOR TEMPORARY TRAFFIC CONTROL ZONE LAYOUTS.

INDEX

SHEET NO.	DESCRIPTION
1	TITLE SHEET
2	GENERAL LAYOUT / ALIGNMENT TAB
3	STATEMENT OF ESTIMATED QUANTITIES,
4	STANDARD PLATES & BASIS OF QUANTITIES
5 - 11	TAB SHEETS
12	SOILS AND CONSTRUCTION NOTES
13 - 14	EARTHWORK SUMMARY
15	EARTHWORK TABULATION AND BALANCE
16 - 17	TYPICAL SECTIONS
18 - 22	MISCELLANEOUS DETAILS
23 - 27	TRAFFIC CONTROL PLAN
28	TRAFFIC CONTROL TABULATION
29	ROLLING SHOULDER CONSTRUCTION PLAN
30 - 35	REMOVALS / UTILITIES
36 - 47	PLAN PROFILE
48	PERMANENT MARKING TABULATION
49 - 53	SIGNING PLAN
54 - 58	STRIPING PLAN
59	PERMANENT SIGNING TABULATION
60 - 65	SIGNING & STRIPING DETAILS
66 - 77	EROSION CONTROL DETAILS
78 - 83	EROSION CONTROL PLAN
84	FLOODPLAIN MITIGATION
85 - 86	SWPPP NARRATIVE
87 - 126	CROSS SECTIONS

THIS PLAN CONTAINS 126 SHEETS

APPROVED  DATE 2/25/19
ANOKA COUNTY ENGINEER

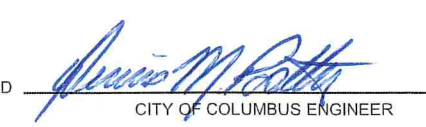
APPROVED  DATE 2/21/19
CITY OF COLUMBUS ENGINEER

REVIEWED FOR COMPLIANCE WITH STATE AID AND FEDERAL AID RULES/POLICY _____,20_____
DISTRICT STATE AID ENGINEER

APPROVED FOR STATE AID AND FEDERAL AID FUNDING _____,20_____
STATE AID ENGINEER

MINNESOTA DEPARTMENT OF TRANSPORTATION ANOKA COUNTY

CONSTRUCTION PLAN FOR SHOULDER GRADING, AGG.BASE, BITUMINOUS SURFACING, BITUMINOUS OVERLAY, DRIVEWAYS & CULVERTS

LOCATED ON CSAH 18 BETWEEN POTOMAC ST NE AND KETTLE RIVER BLVD NE

STATE PROJ. NO. 002-618-032
CSAH 18

GROSS LENGTH 12,538.16 FEET 2.375 MILES
BRIDGES-LENGTH 0.00 FEET 0.000 MILES
EXCEPTIONS-LENGTH 0.00 FEET 0.000 MILES
NET LENGTH 12,538.16 FEET 2.375 MILES

UTILITY NOTE: THE SUBSURFACE UTILITY INFORMATION IN THIS PLAN IS UTILITY QUALITY LEVEL D. THIS QUALITY LEVEL WAS DETERMINED ACCORDING TO THE GUIDELINES OF CI/ASCE 38-02, ENTITLED "STANDARD GUIDELINES FOR THE COLLECTION AND DEPICTION OF EXISTING SUBSURFACE UTILITY DATA".

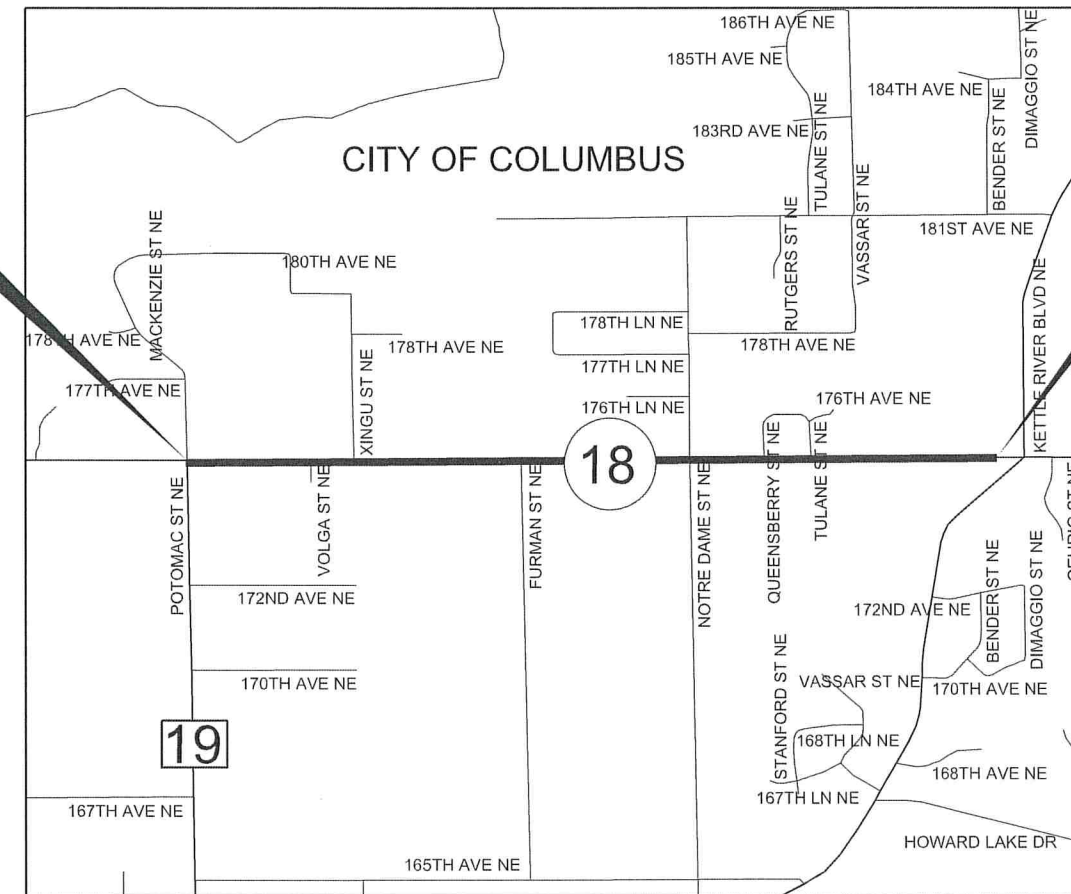

BEGIN S.P. 002-618-032
CSAH 18 STA. 13+73.08

END S.P. 002-618-032
CSAH 18 STA. 139+11.24

PLAN SYMBOLS

- COUNTY LINE
- TOWNSHIP OR RANGE LINE
- SECTION LINE
- QUARTER LINE
- SIXTEENTH LINE
- RIGHT OF WAY LINE
- SLOPE EASEMENT
- EXISTING RIGHT OF WAY
- PROPERTY LINE
- CORPORATE OR CITY LIMITS
- RETAINING WALL
- RAILROAD
- RAILROAD RIGHT OF WAY
- RIVER OR CREEK
- DRAINAGE DITCH
- CULVERT
- DROP INLET
- GUARD RAIL
- BARBED WIRE FENCE
- WOVEN WIRE FENCE
- CHAIN LINK FENCE
- WOOD FENCE
- STONE WALL OR FENCE
- HEDGE
- LOWLAND
- TIMBER
- ORCHARD
- BRUSH
- NURSERY
- CATTLE GUARD
- OVERPASS (Highway Over)
- UNDERPASS (Highway Under)
- BRIDGE
- BUILDING (One Story Frame)
- F-FRAME C-CONCRETE
- S-STONE T-TILE
- B-BRICK ST-STUCCO
- RAILROAD CROSSING BELL
- RAILROAD CROSSING GATE
- MANHOLE
- CATCH BASIN
- FIRE HYDRANT
- CAST IRON MONUMENT
- IRON PIN
- GRAVEL PIT
- SAND PIT
- BORROW PIT
- ROCK QUARRY

UTILITY SYMBOLS

- POWER POLE LINE
- TELEPHONE OR TELEGRAPH POLE LINE
- JOINT TELEPHONE & POWER ON POWER POLES
- ON TELEPHONE POLES
- ANCHOR
- STEEL TOWER
- STREET LIGHT
- PEDESTAL (Cable Terminal)
- GAS MAIN
- WATERMAIN
- TELEPHONE CABLE IN CONDUIT
- ELECTRIC CABLE IN CONDUIT
- TELEPHONE MANHOLE
- ELECTRIC MANHOLE
- BURIED TELEPHONE CABLE
- BURIED ELECTRIC CABLE
- SEWER (Sanitary or Storm)
- SEWER MANHOLE

SCALES

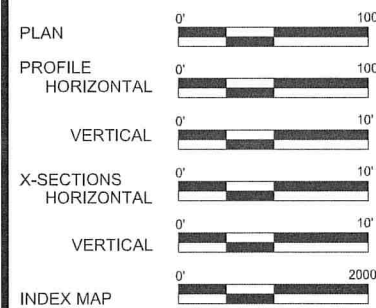

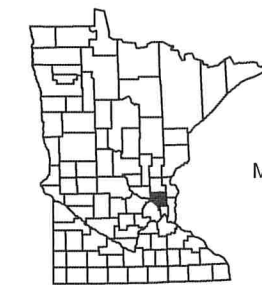

DESIGN DESIGNATION (CSAH 18)

ESAL 20	<u>1,568,042</u>	FUNCTIONAL CLASSIFICATION	<u>A MINOR EXPANDER</u>
R VALUE	<u>40</u>	NO. OF TRAFFIC LANES	<u>2</u> NO. OF PARKING LANES <u>0</u>
ADT (2015)	<u>11685</u>	DESIGN SPEED	<u>55</u> MPH
PROJ. ADT (2039)	<u>17206</u>	STOPPING SIGHT DISTANCE BASED ON:	
PROJ. HCADT	<u>1015</u>	HEIGHT OF EYE	<u>3.5'</u> HEIGHT OF OBJECT <u>2.0'</u>
SOIL FACTOR	<u>NA</u>	DESIGN SPEED NOT ACHIEVED AT:	
	<u>10</u> TON DESIGN	STA. _____ TO STA. _____	MPH _____

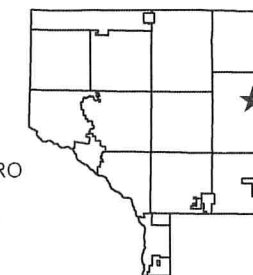

PROJECT LOCATION
CITY OF COLUMBUS
ANOKA COUNTY
MN/DOT DISTRICT - METRO
SECTION 1,2,3,4
TOWNSHIP 32 NORTH
RANGE 22 WEST



I HEREBY CERTIFY THAT THIS PLAN WAS PREPARED BY ME OR UNDER MY DIRECT SUPERVISION AND THAT I AM A DULY LICENSED PROFESSIONAL ENGINEER UNDER THE LAWS OF THE STATE OF MINNESOTA.
PRINT NAME: NICHOLAS DOBDA
SIGNATURE: 
DATE: 2-21-19 LICENSE NO. 49046

DRAWN BY KT DATE 10/24/18
DESIGN BY JCF DATE 10/24/18
CHECKED BY NJD DATE 10/24/18



ANOKA COUNTY
HIGHWAY DEPT.

SP 002-618-032

TITLE SHEET

Sheet 1 of 126 Sheets

BEGIN S.P. 002-618-032
CSAH 18 STA. 13+73.08

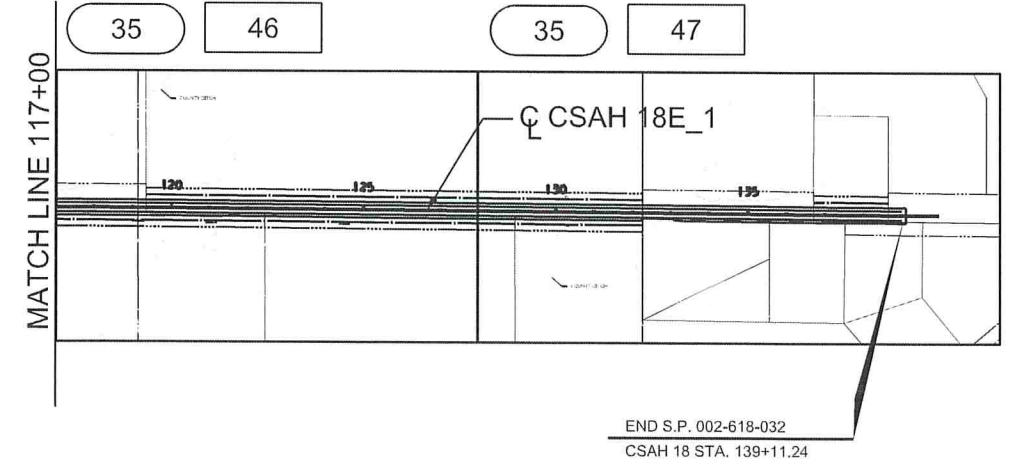
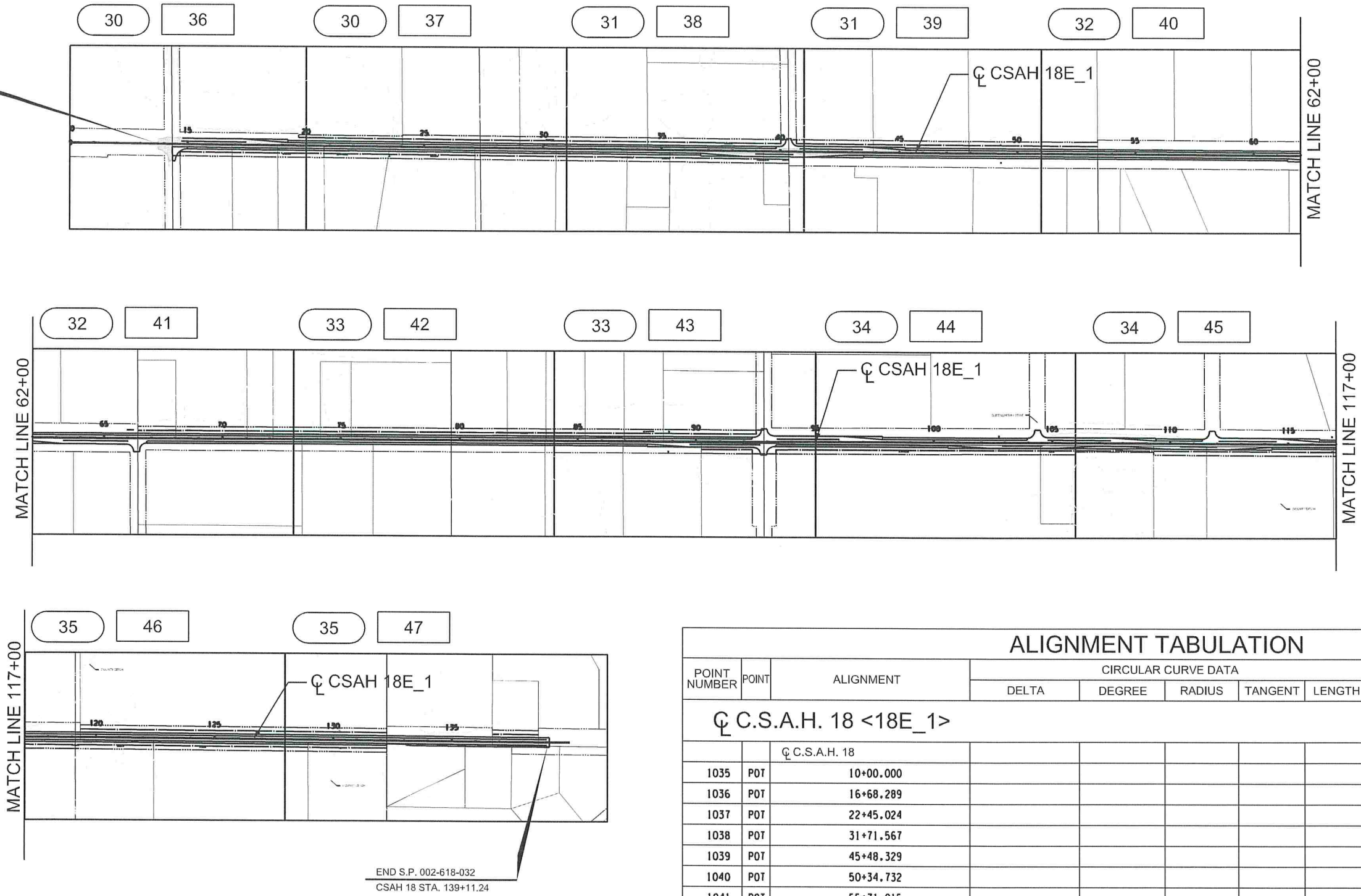

END S.P. 002-618-032
CSAH 18 STA. 139+11.24

LEGEND

XXX INPLACE TOPOGRAPHY AND REMOVAL PLAN SHEET NUMBER

XXX CONSTRUCTION PLAN SHEET NUMBER

ALIGNMENT TABULATION

POINT NUMBER	POINT	ALIGNMENT	CIRCULAR CURVE DATA					COORDINATES		AZIMUTH
			DELTA	DEGREE	RADIUS	TANGENT	LENGTH	E	N	
C.S.A.H. 18 <18E_1>										
C.S.A.H. 18										
1035	POT	10+00.000						547,474.2530	191,776.2210	
1036	POT	16+68.289						548,142.5063	191,769.3056	
1037	POT	22+45.024						548,719.2280	191,765.4090	
1038	POT	31+71.567						549,645.7360	191,757.3940	
1039	POT	45+48.329						551,022.4609	191,747.2922	
1040	POT	50+34.732						551,508.8600	191,745.1930	
1041	POT	55+71.015						552,045.1299	191,741.5028	
1042	POT	65+56.119						553,030.2160	191,735.5510	
1043	POT	78+25.777						554,299.8732	191,733.9223	
1044	POT	89+76.134						555,450.2275	191,731.3040	
1045	POT	97+25.957						556,200.0499	191,731.7514	
1046	POT	104+50.712						556,924.8050	191,731.2510	
1047	POT	119+81.444						558,455.5197	191,724.0465	
1048	POT	139+01.402						560,375.4266	191,710.0269	
1049	POT	139+98.190						560,472.2140	191,710.2830	

NO	DATE	BY	CKD	APPR	REVISION

NAME: P:\002-618-032\Plan\0261832_GL.dgn
01/28/2019 6:50:27 AM

I HEREBY CERTIFY THAT THIS PLAN WAS PREPARED BY ME OR UNDER MY DIRECT SUPERVISION AND THAT I AM A DULY LICENSED PROFESSIONAL ENGINEER UNDER THE LAWS OF THE STATE OF MINNESOTA.

PRINT NAME: NICHOLAS DOBDA
SIGNATURE: *Nicholas Dobda*
DATE: 2-21-19 LICENSE NO. 49046

DRAWN BY: KT DATE: 10/24/18
DESIGN BY: JCF DATE: 10/24/18
CHECKED BY: NJD DATE: 10/24/18

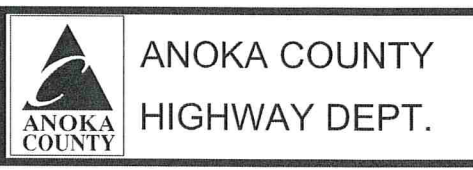

STATE PROJECT NO. SP 002-618-032
STATE PROJECT NO.
STATE PROJECT NO.
STATE PROJECT NO.

GENERAL LAYOUT
Sheet 2 of 126 Sheets

STATEMENT OF ESTIMATED QUANTITIES					PARTICIPATING - FEDERAL FUNDS	NON- PARTICIPATING
TAB / NOTE	ITEM NO.	ITEM DESCRIPTION	UNIT	TOTAL PROJECT QUANTITIES ESTIMATED	ANOKA COUNTY 002-618-032 ROADWAY QUANTITIES ESTIMATED	ANOKA COUNTY 002-618-032 ROADWAY QUANTITIES ESTIMATED
	2021.501	MOBILIZATION	LUMP SUM	1	0.8	0.2
	2031.502	FIELD OFFICE TYPE D	EACH	1	0.8	0.2
A	2101.505	CLEARING	ACRE	0.0	0.0	
A	2101.505	GRUBBING	ACRE	0.3	0.3	
A	2101.524	CLEARING	TREE	0	0	
A	2101.524	GRUBBING	TREE	42	42	
L	2102.503	PAVEMENT MARKING REMOVAL	LIN FT	38	38	
L	2102.518	PAVEMENT MARKING REMOVAL	SQ FT	108	108	
C	2104.502	REMOVE PIPE APRON	EACH	4	4	
N	2104.502	REMOVE SIGN TYPE C	EACH	21	21	
N	2104.502	SALVAGE SIGN TYPE C	EACH	18	18	
N	2104.502	SALVAGE SIGN TYPE D	EACH	3	3	
N	2104.502	SALVAGE SIGN TYPE SPECIAL	EACH	4	4	
B	2104.503	SAWING CONCRETE PAVEMENT (FULL DEPTH)	LIN FT	12	12	
B	2104.503	SAWING BIT PAVEMENT (FULL DEPTH)	LIN FT	22622	22622	
C	2104.503	REMOVE PIPE CULVERTS	LIN FT	790	790	
B	2104.504	REMOVE CONCRETE PAVEMENT	SQ YD	43	43	
B	2104.504	REMOVE BITUMINOUS DRIVEWAY PAVEMENT	SQ YD	1644	1644	
B	2104.504	REMOVE BITUMINOUS PAVEMENT	SQ YD	5636	5636	
B	2104.507	REMOVE RIPRAP	CU YD	20	20	
AA	2105.507	COMMON EXCAVATION	CU YD	10129	10129	
AA	2105.507	SUBGRADE EXCAVATION	CU YD	7804	1997	5807
CC	2105.507	GRANULAR BORROW (LV)	CU YD	3585	918	2667
J	2105.601	TEMPORARY STREAM DIVERSION SYSTEM	LUMP SUM	1	1	
J	2123.610	STREET SWEEPER (WITH PICKUP BROOM)	hour	71	71	
E	2211.507	AGGREGATE BASE (CV) CLASS 5 (P)	CU YD	5751	1472	4279
E	2221.607	RECYCLED SHOULDER MIXTURE (CV)	CU YD	239	239	
B	2232.504	MILL BITUMINOUS SURFACE (2.0")	SQ YD	193	193	
F	2357.506	BITUMINOUS MATERIAL FOR TACK COAT	GALLON	2111	2111	
F	2360.509	TYPE SP 9.5 WEARING COURSE MIX (2 ,B)	TON	259	259	
F	2360.509	TYPE SP 12.5 WEARING COURSE MIX (3,C)	TON	7133	7133	
D	2501.502	36" GS PIPE APRON	EACH	4	4	
D	2501.502	48" GS PIPE APRON	EACH	2	2	
D	2501.502	24" RC PIPE APRON	EACH	4	4	
D	2501.502	15" GS SAFETY APRON	EACH	14	14	
D	2501.502	18" GS SAFETY APRON	EACH	22	22	
D	2501.503	15" CP PIPE CULVERT	LIN FT	232	232	
D	2501.503	18" CP PIPE CULVERT	LIN FT	416	416	
D	2501.503	36" CP PIPE CULVERT (SMOOTH)	LIN FT	16	16	
D	2501.503	36" CS PIPE CULVERT	LIN FT	16	16	
D	2501.503	48" CS PIPE CULVERT	LIN FT	16	16	
D	2501.503	24" RC PIPE CULVERT	LIN FT	32	32	
J	2511.507	RANDOM RIPRAP CLASS II	CU YD	26.6	26.6	
G	2531.504	6" CONCRETE DRIVEWAY PAVEMENT	SQ YD	60	60	
H	2540.602	MAIL BOX SUPPORT	EACH	42	42	
H	2540.602	RELOCATE MAIL BOX SUPPORT	EACH	42	42	
	2563.601	TRAFFIC CONTROL SUPERVISOR	LUMP SUM	1	0.8	0.2
K	2563.601	TRAFFIC CONTROL	LUMP SUM	1	0.8	0.2
K	2563.613	PORTABLE CHANGEABLE MESSAGE SIGN	UDAY	20	20	
N	2564.502	INSTALL SIGN TYPE C	EACH	18	18	

STATEMENT OF ESTIMATED QUANTITIES					PARTICIPATING - FEDERAL FUNDS	NON- PARTICIPATING
TAB / NOTE	ITEM NO.	ITEM DESCRIPTION	UNIT	TOTAL PROJECT QUANTITIES ESTIMATED	ANOKA COUNTY 002-618-032 ROADWAY QUANTITIES ESTIMATED	ANOKA COUNTY 002-618-032 ROADWAY QUANTITIES ESTIMATED
N	2564.502	INSTALL SIGN TYPE D	EACH	3	3	
N	2564.502	INSTALL SIGN TYPE SPECIAL	EACH	4	4	
N	2564.502	DELINEATOR TYPE X4-13	EACH	1	1	
N	2564.502	OBJECT MARKER TYPE X4-3	EACH	12	12	
N	2564.518	SIGN PANELS TYPE C	SQ FT	97.9	97.9	
	2573.501	EROSION CONTROL SUPERVISOR	LUMP SUM	1	1	
J	2573.502	CULVERT END CONTROLS	EACH	18	18	
J	2573.503	SILT FENCE, TYPE MACHINE SLICED	LIN FT	21894	21894	
J	2573.510	SEDIMENT REMOVAL BACKHOE	hour	44	44	
J	2574.507	COMMON TOPSOIL BORROW	CU YD	977	977	
J	2574.508	FERTILIZER TYPE 3	POUND	2590	2590	
J	2575.504	EROSION CONTROL BLANKETS CATEGORY 3	SQ YD	824	824	
J	2575.505	SEEDING	ACRE	7	7	
J	2575.505	DISK ANCHORING	ACRE	7	7	
J	2575.508	SEED MIXTURE 25-121	POUND	451	451	
J	2575.509	MULCH MATERIAL TYPE 1	TON	15	15	
J	2575.523	RAPID STABILIZATION METHOD 3	MGAL	44	44	
F	2580.503	INTERIM PAVEMENT MARKINGS	LIN FT	750	750	
M	2582.503	4" SOLID LINE MULTI COMP	LIN FT	30540	30540	
M	2582.503	4" BROKEN LINE MULTI COMP	LIN FT	2000	2000	
M	2582.503	8" DOTTED LINE MULTI COMP	LIN FT	99	99	
M	2582.503	4" DBLE SOLID LINE MULTI COMP	LIN FT	3130	3130	

(P) DENOTES PLAN QUANTITY

1	04/18/2019	OFF	NJD	NJD	UPDATED SIGNING QUANTITIES
NO	DATE	BY	CKD	APPR	REVISION
NAME: P:\002-618-032\Plan\0261832_SEQ.dgn 04/22/2019 12:47:38 PM					

I HEREBY CERTIFY THAT THIS PLAN WAS PREPARED BY ME OR UNDER MY DIRECT SUPERVISION AND THAT I AM A DULY LICENSED PROFESSIONAL ENGINEER UNDER THE LAWS OF THE STATE OF MINNESOTA.
 PRINT NAME: NICHOLAS DOBDA
 SIGNATURE: 
 DATE: 4/22/19 LICENSE NO. 49046

DRAWN BY: KT DATE: 10/24/18
 DESIGN BY: JCF DATE: 10/24/18
 CHECKED BY: NJD DATE: 10/24/18

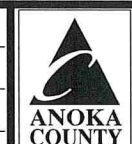

ANOKA COUNTY
HIGHWAY DEPT.

SP 002-618-032

STATEMENT OF ESTIMATED QUANTITIES

Sheet 3 of 126 Sheets

INDEX OF TABULATION CHARTS		
TAB.	DESCRIPTION	SHEET NO.
AA	EARTHWORK SUMMARY	13 - 14
BB	EARTHWORK TABULATION	15
CC	EARTHWORK BALANCE	15
A	CLEAR AND GRUB	5
B	REMOVALS	6
C	CULVERT REMOVAL	7
D	CULVERTS	8
E	AGGREGATE	9
F	BITUMINOUS SUMMARY	10
G	CONCRETE	10
H	MAIL BOXES	10
I	PRIVATE UTILITY OWNERS	9
J	TURF ESTABLISHMENT AND EROSION CONTROL	11
K	TRAFFIC CONTROL TABULATION	28
L	TEMPORARY PAVEMENT MARKING TABULATION	28
M	PERMANENT PAVEMENT MARKING TABULATION	48
N	PERMANENT SIGNING TABULATION	59

BASIS OF QUANTITIES		
SPEC NO	DESCRIPTION	RATE
2123	STREET SWEEPER (WITH PICKUP BROOM)	2.375 MI / 3 MPH X 90 DAYS
2211	AGGREGATE BASE (CV), CLASS 5 (P)	0.0123 CY / SF
2221	RECYCLED SHOULDER MIXTURE (CV)	0.0283 CY / LFT
2357	BITUMINOUS MATERIAL FOR TACK COAT	0.05 GAL / SQ YD / LIFT
2360	TYPE SP 9.5 WEARING COURSE MIXTURE	115 LBS / SQ YD / IN
2360	TYPE SP 12.5 WEARING COURSE MIXTURE	115 LBS / SQ YD / IN
2573	SEDIMENT REMOVAL BACKHOE	1 HR / 500 FT SILT FENCE
2574	FERTILIZER TYPE 3	350 LB / ACRE
2575	SEED MIXTURE 25-121	61 LBS / ACRE
2575	MULCH TYPE 1	2 TONS / ACRE
2575	RAPID STABILIZATION METHOD 3	6 M GALLONS / ACRE

THE FOLLOWING STANDARD PLATES APPROVED BY THE DEPARTMENT OF TRANSPORTATION FEDERAL HIGHWAY ADMINISTRATION SHALL APPLY ON THIS PROJECT.

STANDARD PLATES

PLATE NO.	DESCRIPTION
3000L	REINFORCED CONCRETE PIPE
3006G	GASKET JOINT FOR R.C. PIPE
3022C	PRECAST CONCRETE SAFETY APRON
3100G	CONCRETE APRON FOR REINFORCED CONCRETE PIPE
3123J	METAL APRON FOR C.S. PIPE
3128H	METAL SAFETY APRON & GRATE (2 SHEETS)
3133D	RIPRAP AT RCP OUTLETS
3134D	RIPRAP AT CSP OUTLETS
3145G	CONCRETE PIPE TIES
8000J	STANDARD BARRICADES
8150C	INSTALLATION OF CULVERT MARKERS

NO	DATE	BY	CKD	APPR	REVISION

NAME: P:\002-618-032\Plan\0261832_SEQ.dgn 01/28/2019 6:50:35 AM

I HEREBY CERTIFY THAT THIS PLAN WAS PREPARED BY ME OR UNDER MY DIRECT SUPERVISION AND THAT I AM A DULY LICENSED PROFESSIONAL ENGINEER UNDER THE LAWS OF THE STATE OF MINNESOTA.

PRINT NAME: NICHOLAS DOBDA
SIGNATURE: *[Signature]*
DATE: 2-21-19 LICENSE NO. 49046

DRAWN BY: KT DATE: 10/24/18
DESIGN BY: JCF DATE: 10/24/18
CHECKED BY: NJD DATE: 10/24/18



ANOKA COUNTY
HIGHWAY DEPT.

SP 002-618-032

STANDARD PLATES,
BASIS OF QUANTITIES,
INDEX OF TABS

Sheet 4 of 126 Sheets

CLEARING & GRUBBING										A
ALIGNMENT	STATION	TO	STATION	OFFSET		CLEARING (TREE)	GRUBBING (TREE)	CLEARING (ACRE)	GRUBBING (ACRE)	NOTES
				LEFT	RIGHT					
CSAH 18	21+14				37		1			[2]
	23+32			25			1			[2]
	26+74			38			1			[2]
	29+51			37			1			[2]
	33+51			37			1			[2]
	33+77				40		1			[2]
	34+72			36			1			[2]
	35+90			22			1			[2]
	37+18			30			1			[2]
	39+04				43		1			[2]
	39+46				38		1			[2]
	39+84				40		1			[2]
	40+85			33			1			[2]
	41+63			35			1			[2]
	42+38			33			1			[2]
	43+54			27			1			[2]
	44+09			29			1			[2]
	45+45			32			1			[2]
	46+10		46+80		59				0.1	[1]
	46+16			23			1			[2]
	46+69			28			1			[2]
	47+55			29			1			[2]
	48+94			37			1			[2]
	49+70			41			1			[2]
	56+90		58+50	60					0.1	[1]
	57+06			36			1			[2]
	57+83			37			1			[2]
	58+46			48			1			[2]
	60+75		61+80	60					0	
SUBTOTAL (A)						0	26	0	0.2	

CLEARING & GRUBBING										A
ALIGNMENT	STATION	TO	STATION	OFFSET		CLEARING (TREE)	GRUBBING (TREE)	CLEARING (ACRE)	GRUBBING (ACRE)	NOTES
				LEFT	RIGHT					
CSAH 18	61+08			34			1			[2]
	61+83			39			1			[2]
	65+11			37			1			[2]
	65+64			33			1			[2]
	65+93			30			1			[2]
	71+84			32			1			[2]
	80+00		82+95		50				0	[1]
	80+25				39		1			[3]
	80+55				40		1			[3]
	80+57				32		1			[2]
	82+20				39		1			[2]
	88+42			27			1			[2]
	88+80			56			2			
	89+77			44			1			[2]
	90+37				39		1			[2]
	90+48			47			1			[2]
	104+70		111+25	61					0	[1]
	107+50		107+70		43				0	[1]
	107+95		108+25		43				0	[1]
	111+90		113+90		42				0	[1]
	112+05		113+05	60					0	[1]
	133+15		136+20	60					0	[1]
SUBTOTAL (B)						0	16	0.0	0.0	
PROJECT TOTAL (A+B)						0	42	0.0	0.2	

CLEARING & GRUBBING GENERAL NOTES:
REMOVAL OF MISC. SHRUBS AND LANDSCAPING SHALL BE CONSIDERED INCIDENTAL.
TREES WILL BE MARKED FOR REMOVAL BY ANOKA COUNTY.
[1] CLEAR AND GRUB BY THE ACRE REFLECTS MEASUREMENT 10' OUTSIDE OF SURVEYED TREE BOUNDARY.
[2] TD = TREE DECIDUOUS.
[3] TE = TREE EVERGREEN.

1	04/22/2019	DF	NJD	NJD	CLEARING QUANTITIES REMOVED
NO	DATE	BY	CKD	APPR	REVISION
NAME: P:\002-618-032\Plan\0261832_SEQ.dgn 04/22/2019 12:47:47 PM					

I HEREBY CERTIFY THAT THIS PLAN WAS PREPARED BY ME OR UNDER MY DIRECT SUPERVISION AND THAT I AM A DULY LICENSED PROFESSIONAL ENGINEER UNDER THE LAWS OF THE STATE OF MINNESOTA.
PRINT NAME: NICHOLAS DOBDA
SIGNATURE: *[Signature]*
DATE: 4/22/19 LICENSE NO. 49046

DRAWN BY KT DATE 10/24/18
DESIGN BY JCF DATE 10/24/18
CHECKED BY NJD DATE 10/24/18



ANOKA COUNTY
HIGHWAY DEPT.

SP 002-618-032

TABULATIONS
Sheet 5 of 126 Sheets

REMOVALS, SAWING AND MILLING											B
ALI.	STA. TO STA.	ADDRESS / STREET	OFFSET	REMOVE				SAWING		MILLING	NOTES
				BIT. PAVEMENT	BIT. DRIVEWAY PAVEMENT [5]	CONC. PAVEMENT	RIPRAP [8]	BIT PAVEMENT	CONC. PAVEMENT	BIT. SURFACE (2") [7]	
				(SQ YD)	(SQ YD)	(SQ YD)	(CU YD)	(LIN FT)	(LIN FT)	(SQ YD)	
CSAH 18	13+73	BEG PROJECT	MAINLINE							51	[1]
	13+73 - 20+00		MAINLINE	163				589			[1]
	14+15 - 14+50	POTOMAC ST N.	LT							17	[3], [6]
	14+15 - 14+50	POTOMAC ST S.	RT	159				112		18	[3], [6]
	18+10 - 18+30	7432	RT		40			11			[2]
	19+00 - 19+25	7454	RT		45			11			[2]
	20+00 - 31+00		MAINLINE	546				2200			[1]
	24+25 - 24+55	7541 W.	LT		46			13			[2]
	25+25 - 25+60	7538	RT		50			12			[2]
	25+95 - 26+20	7541 E.	LT		52			14			[2]
	31+00 - 41+00		MAINLINE	510				2000			[1]
	35+05 - 35+30	7704	RT		32			10			[2]
	39+90 - 40+20	XINGU ST	LT		183						[3]
	41+00 - 51+00		MAINLINE	500				2000			[1]
	51+00 - 62+00		MAINLINE	525				2148			[1]
	51+85 - 52+15	7938	RT		46			12			[2]
	62+00 - 73+00		MAINLINE	420				1709			[1]
	66+10 - 66+75	FURMAN ST	RT							12	[3], [6]
	68+50 - 68+85	8233	LT		56			18			[2]
	73+00 - 84+00		MAINLINE	535				2200			[1]
	75+00 - 75+20	8319	LT		38			12			[2]
	76+75 - 77+00	8365	LT		42			11			[2]
	77+50 - 77+85	8460	RT		40			11			[2]
	79+60 - 79+90	8450	RT		45			15			[2]
	82+55 - 82+95	8433	LT			43			12		[4]
	84+00 - 95+00		MAINLINE	478				1940			[1]
	84+01 - 84+30	8449	LT		43			11			[2]
	87+85 - 88+15	8513	LT		78			17			[2]
	92+30 - 93+30	NOTRE DM. S.	RT		221			27		12	[3]
	92+30 - 93+30	NOTRE DM. N.	LT							16	[3], [6]
	95+00 - 106+00		MAINLINE	479				1924			[1]
	98+50 - 99+00	C.R. CHURCH	RT		97			18			[2]
	104+15 - 104+70	QUEENSBERRY ST	LT		132			24		11	[3]
	106+00 - 117+00		MAINLINE	409				1707			[1]
	111+70 - 111+95	TULANE ST	LT		188			120		11	[3]
	116+90	CROSS CULVERT	MAINLINE				20				
	117+00 - 128+00		MAINLINE	537				2200			[1]
	120+90 - 121+20	9014	RT		50			12			[2]
	125+85 - 126+30	9061	LT		88			26			[2]
	128+00 - 139+17		MAINLINE	375				1452			[1]
	136+40 - 136+53	9240	RT		16			17			[2]
	138+40 - 138+56	9262	RT		16			19			[2]
	139+11	END PROJECT	MAINLINE							45	[1]
PROJECT TOTAL				5636	1644	43	20	22622	12	193	

REMOVALS NOTES:
 [1] MAINLINE
 [2] BITUMINOUS DRIVEWAY
 [3] STREET APPROACH
 [4] CONCRETE ENTRANCE
 [5] QUANTITIES FOR BITUMINOUS DRIVEWAYS AND STREET APPROACH REMOVAL.
 [6] MILL JOINT ONLY, TO BE OVERLAYED - NO REMOVAL.
 [7] JOINTS
 [8] RIPRAP REMOVED FOR CROSS CULVERT EXTENTION.

NO	DATE	BY	CKD	APPR	REVISION

NAME: P:\002-618-032\Plan\0261832_SEQ.dgn 01/28/2019 6:50:42 AM

I HEREBY CERTIFY THAT THIS PLAN WAS PREPARED BY ME OR UNDER MY DIRECT SUPERVISION AND THAT I AM A DULY LICENSED PROFESSIONAL ENGINEER UNDER THE LAWS OF THE STATE OF MINNESOTA.
 PRINT NAME: NICHOLAS DOBDA
 SIGNATURE: *Nicholas Dobda*
 DATE: 2-21-19 LICENSE NO. 49046

DRAWN BY: KT DATE: 10/24/18
 DESIGN BY: JCF DATE: 10/24/18
 CHECKED BY: NJD DATE: 10/24/18



ANOKA COUNTY
 HIGHWAY DEPT.

SP 002-618-032

CULVERT REMOVAL												C	
ADDRESS	FLOWS FROM		TO		REMOVE							NOTES	
					15" CP PIPE CUL- VERT	18" CP / RC PIPE CUL- VERT	24" CP PIPE CUL- VERT	27" CP PIPE CUL- VERT	36" CP PIPE CUL- VERT	48" CP PIPE CUL- VERT	PIPE APRON		
	STA	OFFSET	STA	OFFSET	LIN FT	LIN FT	LIN FT	LIN FT	LIN FT	LIN FT	EACH		
7432	17+99	RT	-	18+30	RT								[2]
7454	19+01	RT	-	19+36	RT		35						[1]
7606	21+36	RT	-	21+75	RT		39						[1]
CROSS-CULVERT	23+52	RT	-	23+66	LT								[5], [9], [10]
7541 W.	24+61	LT	-	24+21	LT								[2]
7538	25+59	RT	-	25+26	RT		34						[1]
7541 E.	25+90	LT	-	26+26	LT								[2]
7622	29+07	RT	-	29+37	RT								[2]
7633	30+10	LT	-	30+46	LT								[2]
7644	33+41	RT	-	33+72	RT		32						[1]
7704	35+00	RT	-	35+30	RT	34							[1]
7745	37+64	LT	-	37+93	LT	30							[1]
7765 W.	39+12	RT	-	39+46	RT		35						[1]
7765 W.	40+05	RT	-	40+40	RT		35						[1]
SITUS	43+31	RT	-	42+89	RT								[2]
CROSS-CULVERT	49+30	RT	-	49+31	LT				12				[8], [10]
7938	52+53	RT	-	51+74	RT								[2]
SITUS	55+06	RT	-	55+44	RT				40				[3]
SITUS	56+29	LT	-	56+81	LT								[2]
8173	66+00	LT	-	66+31	LT	31							[1]
8207	67+67	LT	-	68+03	LT	35							[1]
8233	68+49	LT	-	68+80	LT	36							[1]
8319	74+96	LT	-	75+27	LT	31							[1]
8365	76+68	LT	-	76+98	LT								[2]
8415	81+56	LT	-	81+86	LT	30							[1]
8460	77+59	RT	-	77+86	RT								[2]
8450	79+60	RT	-	79+91	RT								[2]
8433	82+58	LT	-	82+87	LT		30						[1]
8449	84+01	LT	-	84+32	LT								[2]
8463	85+36	LT	-	85+57	LT								[2]
8462	86+96	RT	-	86+34	RT								[2]
8513	87+76	LT	-	88+21	LT		45						[1]

CULVERT REMOVAL												C	
ADDRESS	FLOWS FROM		TO		REMOVE							NOTES	
					15" CP PIPE CUL- VERT	18" CP / RC PIPE CUL- VERT	24" CP PIPE CUL- VERT	27" CP PIPE CUL- VERT	36" CP PIPE CUL- VERT	48" CP PIPE CUL- VERT	PIPE APRON		
	STA	OFFSET	STA	OFFSET	LIN FT	LIN FT	LIN FT	LIN FT	LIN FT	LIN FT	EACH		
CROSS-CULVERT	88+82	RT	-	88+85	LT							2	[4], [6]
CHURCH	98+86	RT	-	98+50	RT	36							[1]
CROSS-CULVERT	102+76	LT	-	102+76	RT							2	[4], [6]
QUEENSBERRY ST	104+15	LT	-	104+59	LT								[2]
8760 W.	105+09	RT	-	104+79	RT	30							[1]
8816	107+67	RT	-	107+97	RT	30							[1]
CROSS-CULVERT	116+84	LT	-	116+84	RT			8		12			[7], [8], [10]
8962	119+31	RT	-	118+97	RT	35							[1]
9014	121+20	RT	-	120+90	RT	30							[1]
9056	124+37	RT	-	124+66	RT	30							[1]
9061	126+31	LT	-	125+80	LT								[2]
CROSS-CULVERT	130+28	LT	-	130+30	RT							15	[5], [9], [10]
CEMETARY W.	133+38	RT	-	133+03	RT								[2]
CEMETARY E.	134+98	RT	-	134+64	RT								[2]
9221	136+28	LT	-	136+69	LT								[2]
9262	138+72	RT	-	138+41	RT								[2]
SUB TOTAL					418	285	8	40	24	15	4		

TOTAL CULVERT REMOVAL LIN FT 790

APRONS 4

- [1] REMOVE AND REPLACE INPLACE CULVERT. LENGTH OF REMOVAL INCLUDES APRON. APRON REMOVED WITH PIPE IS INCIDENTAL TO REMOVAL OF PIPE.
- [2] INPLACE CULVERT TO REMAIN INPLACE.
- [3] INPLACE CULVERT TO BE REMOVED AND NOT REPLACED. LENGTH OF REMOVAL INCLUDES APRONS. APRON INCIDENTAL TO PIPE REMOVAL.
- [4] REMOVE CROSS-CULVERT APRON, PAID BY THE EACH. PIPE TO BE EXTENDED & APRON INSTALLED.
- [5] REMOVE SOUTH APRON ONLY.
- [6] 24" RC APRON.
- [7] 24" GS APRON.
- [8] 36" GS APRON.
- [9] 48" GS APRON.
- [10] REMOVE CROSS-CULVERT APRON, PIPE TO BE EXTENDED. LENGTH OF REMOVAL INCLUDES APRON

NO	DATE	BY	CKD	APPR	REVISION

I HEREBY CERTIFY THAT THIS PLAN WAS PREPARED BY ME OR UNDER MY DIRECT SUPERVISION AND THAT I AM A DULY LICENSED PROFESSIONAL ENGINEER UNDER THE LAWS OF THE STATE OF MINNESOTA.
 PRINT NAME: NICHOLAS DOBDA
 SIGNATURE: *[Signature]*
 DATE: 2-21-19 LICENSE NO. 49046

DRAWN BY: KT DATE: 10/24/18
 DESIGN BY: JCF DATE: 10/24/18
 CHECKED BY: NJD DATE: 10/24/18

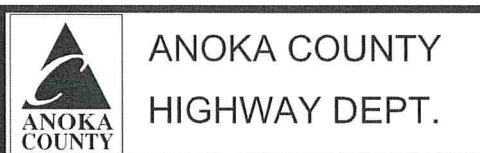

SP 002-618-032

TABULATIONS
 Sheet 7 of 126 Sheets

CULVERTS																	D		
ADDRESS	FLOWS FROM			TO			15" CP PIPE CULVERT	18" CP PIPE CULVERT	24" RC PIPE CULVERT	36" CS PIPE CULVERT	36" CP SMOOTH CULVERT	48" CS PIPE CULVERT	15" GS SAFETY APRON	18" GS SAFETY APRON	24" RC PIPE APRON	36" GS PIPE APRON	48" GS PIPE APRON	NOTES	
	STA	OFFSET	INV	STA	OFFSET	INV	LIN FT	LIN FT	LIN FT	LIN FT	LIN FT	LIN FT	EACH	EACH	EACH	EACH	EACH		
7454	19+01.22	36.49	RT	901.32	19+35.95	36.68	RT	900.85		35				2					
7606	21+29.72	36.22	RT	900.29	21+76.59	36.53	RT	900.00		47				2					
CROSS-CULVERT	23+65.86	-41.63	LT	895.85	23+50.86	44.97	RT	895.42				8					1	[1],[3],[4]	
7538	25+58.57	37.56	RT	900.57	25+25.93	38.03	RT	900.39		33				2					
7633	30+10.27	37.44	LT	901.59	30+46.08	37.56	LT	900.79	38				2						
7644	33+80.85	34.07	RT	903.00	33+30.74	34.20	RT	902.75		50				2					
7704	35+35.40	36.13	RT	903.00	35+00.47	36.21	RT	903.00		35				2					
7765 W.	39+53.80	37.08	RT	903.88	39+03.11	37.00	RT	903.88		50				2					
7765 E.	40+36.77	35.71	RT	903.88	40+07.10	35.65	RT	903.88		30				2					
CROSS-CULVERT	49+29.78	-39.25	LT	902.26	49+31.57	42.95	RT	901.49			16					2		[2],[3],[4]	
8173	66+27.60	-35.20	LT	907.21	65+98.08	-35.31	LT	907.21		30				2					
8207	67+73.51	-34.21	LT	908.24	68+04.42	-33.89	LT	908.19		31				2					
8433	82+57.60	-31.63	LT	908.69	82+86.86	-31.83	LT	908.50		30				2					
8513	87+76.15	-41.00	LT	906.86	88+21.06	-41.56	LT	906.43		45				2					
CROSS-CULVERT	88+81.94	47.51	RT	904.82	88+84.74	-46.18	LT	904.73			16				2			[2],[3],[4]	
CHURCH	98+49.89	38.60	RT	909.72	98+95.30	39.11	RT	909.72	45				2						
CROSS-CULVERT	102+75.84	-30.94	LT	908.97	102+75.85	28.32	RT	908.93			16				2			[2],[3],[4]	
8760 W.	105+09.25	36.72	RT	910.77	104+84.94	36.85	RT	910.01	24				2						
8816	107+67.66	29.50	RT	911.28	107+99.93	29.50	RT	911.21	32				2						
CROSS-CULVERT	116+83.55	-36.04	LT	896.89	116+84.39	34.39	RT	896.97				16				2		[2],[3],[4]	
8962	119+31.43	34.90	RT	901.62	118+97.13	34.44	RT	901.04	34				2						
9014	121+20.52	36.12	RT	902.05	120+90.21	36.34	RT	901.42	30				2						
9056	124+36.90	36.61	RT	902.73	124+66.22	36.56	RT	901.93	29				2						
CROSS-CULVERT	130+28.27	-42.34	LT	896.20	130+30.54	38.13	RT	895.57				8					1	[1],[3],[4]	
PROJECT TOTAL								232	416	32	16	16	16	14	22	4	4	2	

GENERAL NOTES:

STATION AND OFFSET IS AT THE END OF PIPE, NOT END OF APRON.
 PIPE LENGTH LIN FT IS FOR PIPE ONLY.
 ELEVATION GIVEN IS END OF APRON.

- [1] REMOVE INPLACE SOUTH APRON, ADD 8' OF ADDITIONAL 48" CS PIPE. INSTALL NEW 48" APRON. SOUTH SIDE ONLY.
- [2] REMOVE BOTH APRONS, ADD 8' ADDITIONAL PIPE TO BOTH ENDS, INSTALL NEW APRONS.
- [3] RIPRAP LOW INVERT OF CROSS PIPES. SEE DETAILS.
- [4] SEWER ROCK USED FOR PIPE BEDDING IN WET AREAS SHALL BE INCIDENTAL TO THE PIPE APRON.

NO	DATE	BY	CKD	APPR	REVISION

NAME: P:\002-618-032\Plan\0261832_SEQ.dgn 01/28/2019 6:50:52 AM

I HEREBY CERTIFY THAT THIS PLAN WAS PREPARED BY ME OR UNDER MY DIRECT SUPERVISION AND THAT I AM A DULY LICENSED PROFESSIONAL ENGINEER UNDER THE LAWS OF THE STATE OF MINNESOTA.
 PRINT NAME: NICHOLAS DOBDA
 SIGNATURE: *[Signature]*
 DATE: 2-21-19 LICENSE NO. 49046

DRAWN BY: KT DATE: 10/24/18
 DESIGN BY: JCF DATE: 10/24/18
 CHECKED BY: NJD DATE: 10/24/18

ANOKA COUNTY
HIGHWAY DEPT.



SP 002-618-032

AGGREGATE							E	
ALI.	ADDRESS	STA.	TO STA.	LOCATION	DESCRIPTION	AGGREGATE BASE CLASS 5 (CV) [1]	RECYCLE SHLD. MIXTURE (CV) [3]	NOTES
						CU YD	CU YD	
CSAH 18	MAINLINE	13+73	- 20+00	MAINLINE		209	12	
	7432	17+91	- 18+32	RT	BIT DR	3		[2]
	7454	18+98	- 19+39	RT	BIT DR	4		[2]
	MAINLINE	20+00	- 31+00	MAINLINE		500	21	
	7606	21+32	- 21+75	RT	GRVL DR	5		[2]
	7541 W.	24+19	- 24+61	LT	BIT DR	4		[2]
	7538	25+23	- 25+64	RT	BIT DR	5		[2]
	7541 E.	25+88	- 26+31	LT	BIT DR	4		[2]
	7605	28+64	- 29+06	LT	GRVL DR	3		[2]
	7622	28+99	- 29+44	RT	GRVL DR	4		[2]
	7633	30+05	- 30+51	LT	GRVL DR	6		[2]
	MAINLINE	31+00	- 41+00	MAINLINE		484	19	
	7644	33+32	- 33+80	RT	GRVL DR	5		[2]
	7704	34+98	- 35+38	RT	BIT DR	4		[2]
	7745	37+59	- 37+99	LT	GRVL DR	3		[2]
	7765 W.	39+08	- 39+50	RT	GRVL DR	4		[2]
	XINGU ST	40+00	- 40+75	LT	ST APPROACH	19		[4]
	7765 E.	40+02	- 40+47	RT	GRVL DR	5		[2]
	MAINLINE	41+00	- 51+00	MAINLINE		492	19	
	SITUS	42+84	- 43+35	RT	GRVL DR	5		[2]
	7847	44+48	- 44+88	RT	GRVL DR	3		[2]
	MAINLINE	51+00	- 62+00	MAINLINE		491	21	
	7938	51+38	- 52+16	RT	BIT DR	3		[2]
	MAINLINE	52+21	- 52+50	RT	GRVL DR	3		[2]
	8023 / 8145	56+24	- 56+93	LT	GRVL DR	8		[2]
	MAINLINE	62+00	- 73+00	MAINLINE		425	21	
	8173	65+90	- 66+36	LT	GRVL DR	5		[2]
	8207	67+71	- 68+10	LT	GRVL DR	3		[2]
	8233	68+40	- 68+88	LT	BIT DR	4		[2]
	8245	71+15	- 71+67	LT	GRVL DR	4		[2]
	17453	71+53	- 71+96	RT	GRVL DR	3		[2]
	MAINLINE	73+00	- 84+00	MAINLINE		499	21	
	8305	73+50	- 74+00	LT	GRVL DR	5		[2]
	8319	74+88	- 75+30	LT	BIT DR	3		[2]
	8365	76+60	- 77+00	LT	BIT DR	3		[2]
	8460	77+51	- 77+92	RT	BIT DR	3		[2]
	8450	79+52	- 79+98	RT	BIT DR	4		[2]
	8415	81+52	- 81+92	LT	GRVL DR	3		[2]
	8433	82+53	- 82+95	LT	CONC	3		[2]
	MAINLINE	84+00	- 95+00	MAINLINE		490	21	
	8449	84+00	- 84+35	LT	BIT DR	3		[2]
	8463	85+25	- 85+68	LT	GRVL DR	4		[2]
	8462	86+47	- 86+93	RT	GRVL DR	3		[2]
	8513	87+75	- 88+22	LT	BIT DR	7		[2]
	17422	90+80	- 91+19	RT	GRVL DR	3		[2]
	NOTRE DAME ST S.	92+50	- 93+25	RT	ST APPROACH	22		[4]
	MAINLINE	95+00	- 106+00	MAINLINE		496	21	

AGGREGATE							E	
ALI.	ADDRESS	STA.	TO STA.	LOCATION	DESCRIPTION	AGGREGATE BASE CLASS 5 (CV) [1]	RECYCLE SHLD. MIXTURE (CV) [3]	NOTES
						CU YD	CU YD	
	CHURCH	98+44	- 98+93	RT	BIT DR	8		[2]
	QUEENSBERRY ST	104+00	- 104+75	LT	ST APPROACH	23		[4]
	8760 W.	104+76	- 105+16	RT	GRVL DR	3		[2]
	8760 E.	105+57	- 105+95	RT	GRVL DR	3		[2]
	MAINLINE	106+00	- 117+00	MAINLINE		490	21	
	8816	107+63	- 108+07	RT	GRVL DR	4		[2]
	8842	109+76	- 110+24	RT	GRVL DR	6		[2]
	TULANE ST	111+50	- 112+20	LT	ST APPROACH	21		[4]
	MAINLINE	117+00	- 128+00	MAINLINE		499	21	
	8962	118+95	- 119+39	RT	GRVL DR	4		[2]
	9014	120+83	- 121+25	RT	BIT DR	5		[2]
	9056	124+25	- 124+73	RT	GRVL DR	6		[2]
	9061	125+71	- 126+31	LT	BIT DR	6		[2]
	MAINLINE	128+00	- 139+18	MAINLINE		385	21	
	CEM. W.	133+10	- 133+39	RT	GRVL DR	2		[2]
	CEM. E.	134+71	- 134+98	RT	GRVL DR	2		[2]
	9221	136+22	- 136+74	LT	GRVL DR	5		[2]
	9240	136+28	- 136+62	RT	BIT DR	2		[2]
	9257	137+43	- 137+94	LT	GRVL DR	4		[2]
	9262	138+42	- 138+71	RT	BIT DR	2		[2]
TOTAL						5751	239	

AGGREGATE NOTES

- [1] CLASS 5 QUANTITY FOR NEW PAVED BIT SHOULDERS/TURN/BYPASS AREAS (CL-5, 6 INCH DEPTH)
- [2] QUANTITY FOR GRAVEL, BITUMINOUS AND CONCRETE DRIVEWAYS (CL-5, 4 INCH DEPTH ON ALL DRIVEWAYS)
- [3] 1.5' WIDE RECYCLE GRAVEL SHOULDER (RECYCLE, 2 INCH DEPTH)
- [4] 4" CLASS 5 GRAVEL FOR RECONSTRUCTED STREET APPROACHES.

UTILITY OWNERS			I
CCOLUM01	CITY OF COLUMBUS	(651) 464-3120	
CTLMN01	CENTURYLINK - CTLQL	(800) 283-4237	
EANOCA01	CONNEXUS ENERGY	(763) 323-4215	
MIDCBL21	MIDCONTINENT COMMUNICATIONS	(605) 271-0202	
MINGAS03	CENTER POINT ENERGY	(800) 778-9140	
WILPIP01	MAGELLAN MIDSTREAM PARTNERS	(918) 574-7098	
XCELO3	XCEL ENERGY	(651) 229-2552	
ZAYO04	ZAYO BANDWIDTH	(888) 267-1063	

NO	DATE	BY	CKD	APPR	REVISION

NAME: P:\002-618-032\Plan\0261832_SEQ.dgn 01/28/2019 6:50:58 AM

I HEREBY CERTIFY THAT THIS PLAN WAS PREPARED BY ME OR UNDER MY DIRECT SUPERVISION AND THAT I AM A DULY LICENSED PROFESSIONAL ENGINEER UNDER THE LAWS OF THE STATE OF MINNESOTA.

PRINT NAME: NICHOLAS DOBDA

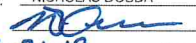
SIGNATURE: 

DATE: 2-21-19 LICENSE NO. 49046

DRAWN BY: KT DATE: 10/24/18

DESIGN BY: JCF DATE: 10/24/18

CHECKED BY: NJD DATE: 10/24/18

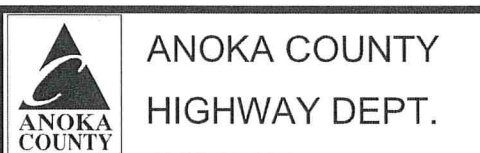

SP 002-618-032

TABULATIONS

Sheet 9 of 126 Sheets

BITUMINOUS SUMMARY								F	
ALI	ADDRESS	STA. TO	STA.	LOCATION	BITUMINOUS				NOTES
					2360 TYPE SP 12.5 WEARING COURSE MIX (3,C)	2360 TYPE SP 9.5 WEARING COURSE MIX (2,B)	2357 BITUMINOUS TACK COAT	INTERIM PAVEMENT MARKINGS	
					TON	TON	GALLON	LIN FT	
CSAH 18	MAINLINE	13+73	- 20+00	MAINLINE	384		134		[1]
		13+73	138+71	MAINLINE				750	[6]
	POTOMAC S.	13+73	- 14+75	RT		18	8		[2] , [4]
	POTOMAC N.	13+73	- 14+75	LT		17	7		[2] , [4]
	7432	17+91	- 18+32	RT		3			[3]
	7454	18+98	- 19+39	RT		4			[3]
	MAINLINE	20+00	- 31+00	MAINLINE	562		147		[1]
	7541 W.	24+19	- 24+61	LT		4			[3]
	7538	25+23	- 25+64	RT		5			[3]
	7541 E.	25+88	- 26+31	LT		4			[3]
	MAINLINE	31+00	- 41+00	MAINLINE	608		167		[1]
	7704	34+98	- 35+38	RT		4			[3]
	XINGU ST	40+00	- 40+75	LT		26	6		[2] , [5]
	MAINLINE	41+00	- 51+00	MAINLINE	632		175		[1]
	MAINLINE	51+00	- 62+00	MAINLINE	556		147		[1]
	7938	51+83	- 52+16	RT		4			[3]
	MAINLINE	62+00	- 73+00	MAINLINE	594		182		[1]
	FURMAN ST	66+00	- 66+75	RT		14	6		[2] , [4]
	8233	68+40	- 68+88	LT		5			[3]
	MAINLINE	73+00	- 84+00	MAINLINE	562		147		[1]
	8319	74+88	- 75+30	LT		3			[3]
	8365	76+60	- 77+00	LT		3			[3]
	8460	77+51	- 77+92	RT		4			[3]
	8450	79+52	- 79+98	RT		4			[3]
	MAINLINE	84+00	- 95+00	MAINLINE	673		198		[1]
	8449	84+00	- 84+35	LT		3			[3]
	8513	87+75	- 88+22	LT		8			[3]
	NOTRE DAME N.	92+50	- 93+25	LT		15	6		[2] , [4]
	NOTRE DAME S.	92+50	- 93+25	RT		29	6		[2] , [5]
	MAINLINE	95+00	- 106+00	MAINLINE	711		213		[1]
	CHURCH	98+44	- 98+93	RT		8			[3]
	QUEENSBERRY ST	104+00	- 104+75	LT		30	7		[2] , [5]
	MAINLINE	106+00	- 117+00	MAINLINE	802		254		[1]
	TULANE ST	111+50	- 112+20	LT		28	6		[2] , [5]
	MAINLINE	117+00	- 128+00	MAINLINE	562		147		[1]
	9014	120+83	- 121+25	RT		5			[3]
	9061	125+71	- 126+31	LT		7			[3]
	MAINLINE	128+00	- 139+17	MAINLINE	487		148		[1]
	9240	136+28	- 136+62	RT		2			[3]
	9262	138+42	- 138+71	RT		2			[3]
PROJECT TOTAL					7133	259	2111	750	

BITUMINOUS SUMMARY NOTES:
 [1] QUANTITY FOR MAINLINE CONSTRUCTION
 [2] QUANTITY FOR STREET APPROACH.
 [3] QUANTITY FOR BITUMINOUS DRIVEWAY CONSTRUCTION
 [4] OVERLAY EXISTING STREET APPROACH 2"
 [5] FULL DEPTH STREET APPROACH 4" TOTAL BIT, PAVED IN 2 LIFTS.
 [6] INTERIM PAVEMENT MARKINGS PLACED ON NEW BIT PRIOR TO PERMANENT STRIPING. BASED ON PROJECT LENGTH DIVIDED BY 50' X 3' SKIPS.

CONCRETE							G
ALIGNMENT	ADDRESS	STATION			OFFSET	6" CONCRETE DRIVEWAY PAVEMENT	
		BEGIN	TO	END			
EB CSAH 18	8433	82+55	-	82+95	-20.0 LEFT	60	
CONCRETE TOTAL						60	

MAIL BOXES								H
ADDRESS	ALIGNMENT	STATION	DRIVEWAY LOCATION	BOX LOCATION	MAIL BOX SUPPORT	RELOCATE MAIL BOX SUPPORT	NOTES	
7432	EB 18	18+12	RT	LT	1	1		
7454	EB 18	19+19	RT	LT	1	1		
7606	EB 18	22+04	RT	LT	1	1		
7538	EB 18	25+45	RT	LT	1	1		
7541	EB 18	25+83	LT	LT	1	1		
7605	EB 18	29+05	LT	LT	1	1		
7622	EB 18	29+38	RT	LT	1	1		
7633	EB 18	30+61	LT	LT	1	1		
7644	EB 18	33+45	RT	LT	2	2		
7700	EB 18	33+66	RT	LT	1	1		
7704	EB 18	35+19	RT	LT	1	1		
7745	EB 18	38+01	LT	LT	1	1		
7756	EB 18	38+91	RT	LT	1	1		
7847	EB 18	44+43	LT	LT	1	1		
8203	EB 18	56+27	LT	LT	1	1		
8207	EB 18	67+79	LT	LT	1	1		
8233	EB 18	68+46	LT	LT	1	1		
8245	EB 18	71+08	LT	LT	1	1		
8305	EB 18	73+24	LT	LT	1	1		
8319	EB 18	74+86	LT	LT	1	1		
8365	EB 18	77+07	LT	LT	1	1		
8460	EB 18	77+78	RT	LT	1	1		
8450	EB 18	79+90	RT	LT	1	1		
8415	EB 18	81+98	LT	LT	1	1		
8433	EB 18	83+11	LT	LT	1	1		
8449	EB 18	84+43	LT	LT	1	1		
8463	EB 18	85+29	LT	LT	1	1		
8462	EB 18	86+77	RT	LT	1	1		
8513	EB 18	87+64	LT	LT	1	1		
8760	EB 18	105+94	RT	RT	1	1		
8816	EB 18	108+19	RT	RT	1	1		
8842	EB 18	110+25	RT	RT	1	1		
8962	EB 18	118+84	RT	RT	1	1		
9014	EB 18	121+22	RT	RT	1	1		
9056	EB 18	124+68	RT	RT	1	1		
9061	EB 18	125+68	LT	LT	1	1		
9240	EB 18	136+61	RT	RT	1	1		
9221	EB 18	136+75	LT	RT	1	1		
9257	EB 18	137+92	LT	RT	1	1		
9262	EB 18	138+35	RT	RT	2	2		
TOTALS					42	42		

I HEREBY CERTIFY THAT THIS PLAN WAS PREPARED BY ME OR UNDER MY DIRECT SUPERVISION AND THAT I AM A DULY LICENSED PROFESSIONAL ENGINEER UNDER THE LAWS OF THE STATE OF MINNESOTA. PRINT NAME: NICHOLAS DOBDA SIGNATURE: <i>[Signature]</i> DATE: 2-21-19 LICENSE NO. 49046					DRAWN BY: KT DATE 10/24/18 DESIGN BY: JCF DATE 10/24/18 CHECKED BY: NJD DATE 10/24/18	ANOKA COUNTY HIGHWAY DEPT.	SP 002-618-032	TABULATIONS Sheet 10 of 126 Sheets		
NO	DATE	BY	CKD	APPR	REVISION					
NAME: P:\002-618-032\Plan\0261832_SEQ.dgn					01/28/2019	6:51:03 AM				

TURF ESTABLISHMENT AND EROSION CONTROL

J

LOCATION			TEMPORARY EROSION CONTROL					PERMANENT EROSION CONTROL								TEMP STREAM DIVERSION SYSTEM [1]
			SILT FENCE TYPE MACHINE SLICED [2]	SEDIMENT REMOVAL BACKHOE [11]	STREET SWEEPER WITH PICKUP BROOM [12]	CULVERT END CONTROLS [3]	RAPID STABILIZATION METHOD 3 [4]	SEEDING [5]	SEED MIXTURE 25-121 [5]	MULCH MATERIAL TYPE 1 [6]	DISK ANCHORING [7]	FERTILIZER TYPE 3 [7]	COMMON TOPSOIL BORROW [10]	EROSION CONTROL BLANKETS CAT. 3 [8]	RIPRAP CLASS II [9]	
STATION TO	STATION	OFFSET	LIN FT	HOUR	HOUR	EACH	MGAL	ACRE	POUND	TON	ACRE	POUND	CU YD	SQ YD	CU YD	
13+73	139+18				71											
13+73	- 20+00	LT	82	0.2			0.6	0.1	6.1	0.2	0.1	35	3			
13+73	- 20+00	RT	573	1.1		1	0.6	0.1	6.1	0.2	0.1	35	16	26		
20+00	- 31+00	LT	1050	2.1			1.8	0.3	18.3	0.6	0.3	105	41	50		
20+00	31+00	RT	1083	2.2		2	2.4	0.4	24.4	0.8	0.4	140	54	52		
23+65		RT												50	ANTICIPATED	
31+00	- 41+00	LT	976	2.0			2.4	0.4	24.4	0.8	0.4	140	49			
31+00	- 41+00	RT	966	1.9		4	1.8	0.3	18.3	0.6	0.3	105	41	104		
41+00	- 51+00	LT	993	2.0			1.8	0.3	18.3	0.6	0.3	105	41			
41+00	- 51+00	RT	984	2.0			2.4	0.4	24.4	0.8	0.4	140	48			
49+29		LT												34		
49+29		RT												36	ANTICIPATED	
51+00	- 62+00	LT	1065	2.1			1.8	0.3	18.3	0.6	0.3	105	38			
51+00	- 62+00	RT	1030	2.1			2.4	0.4	24.4	0.8	0.4	140	51			
62+00	- 73+00	LT	1043	2.1		2	1.8	0.3	18.3	0.6	0.3	105	37	52		
62+00	- 73+00	RT	656	1.3			1.2	0.2	12.2	0.4	0.2	70	24			
73+00	- 84+00	LT	1069	2.1		1	1.2	0.2	12.2	0.4	0.2	70	28	26		
73+00	- 84+00	RT	1082	2.2			1.8	0.3	18.3	0.6	0.3	105	44			
84+00	- 95+00	LT	862	1.7		1	2.4	0.4	24.4	0.8	0.4	140	48	26		
84+00	- 95+00	RT	1090	2.2			2.4	0.4	24.4	0.8	0.4	140	55			
88+82		LT												18	ANTICIPATED	
88+82		RT												16		
95+00	- 106+00	LT	817	1.6		1	2.4	0.4	24.4	0.8	0.4	140	50	16		
95+00	- 106+00	RT	1063	2.1		2	2.4	0.4	24.4	0.8	0.4	140	58	38		
102+75		LT												16		
102+75		RT												18	ANTICIPATED	
106+00	- 117+00	LT	687	1.4			1.8	0.3	18.3	0.6	0.3	105	38			
106+00	- 117+00	RT	1085	2.2		1	1.8	0.3	18.3	0.6	0.3	105	46	19		
116+83		LT												34		
116+83		RT												36	10.6 ANTICIPATED	
117+00	- 128+00	LT	1124	2.2			2.4	0.4	24.4	0.8	0.4	140	59			
117+00	- 128+00	RT	1079	2.2		3	1.8	0.3	18.3	0.6	0.3	105	43	57		
128+00	- 139+18	LT	960	1.9			1.8	0.3	18.3	0.6	0.3	105	42	50		
128+00	- 139+18	RT	475	1.0			1.2	0.2	12.2	0.4	0.2	70	23			
130+28		RT												50	16.0	
PROJECT TOTAL			21,894	43.9	71	18	44.4	7.4	451.4	14.8	7.4	2590	977	824	26.6	1

NOTES:

[1] TEMP STREAM DIVERSION ANTICIPATED FOR CROSS CULVERT EXTENTIONS. PAID FOR BY LUMP SUM FOR ALL STREAM DIVERSIONS NEEDED FOR ALL CULVERT EXTENTIONS ON PROJECT.

[2] LOCATION OF PROPOSED SILT FENCE TO BE LAID OUT BY ENGINEER PRIOR TO INSTALLATION.

[3] PLACED AT HIGH INVERT OF CULVERT LOCATED WITHIN THE PROJECTS CONSTRUCTION LIMITS AND SILT FENCE.

[4] BASED ON 6 MGAL PER ACRE FOR TEMP SEEDING EXPOSED SOILS PRIOR TO FINISH SEEDING.

[5] SEED MIXTURE 25-121 APPLIED AT A RATE OF 61 LBS PER ACRE

[6] MULCH APPLIED AT A RATE OF 2 TONS PER ACRE.

[7] FERTILIZER APPLIED AT A RATE OF 350 LBS PER ACRE.

[8] BLANKET USED AT ALL DISTURBED CULVERT APRONS, SEE DETAILS, "TURF ESTABLISHMENT DETAIL AT CULVERT ENDS".

[9] PLACED ON OUTLET END OF CROSS-CULVERT PIPES, GEO-TEXTILE FILTER AND GRANULAR FILTER PLACED UNDER RIPRAP SHALL BE INCIDENTAL. SEE DETAILS, " RIPRAP AT OUTLETS - 3133D & 3134D".

[10] INPLACE TOPSOIL TO BE STRIPPED AND USED FOR FINAL SEEDING. ADDITIONAL TOPSOIL WILL BE NEEDED. FOR ESTIMATING PURPOSES AN ADDITIONAL 25% OF THE TOTAL SEEDING AREA X 4" TOPSOIL WAS USED FOR CALCULATION.

[11] SILT FENCE TO BE MAINTAINED. REMOVAL OF SEDIMENT ALONG SILT FENCE.

[12] ROADWAY TO BE KEPT FREE OF SOILS; DUST CONTROL. AREAS OF CONSTRUCTION ACTIVITY MUST BE SWEEPED AT THE END OF EACH WORKING DAY AND AS DIRECTED BY ENGINEER.

NO	DATE	BY	CKD	APPR	REVISION

I HEREBY CERTIFY THAT THIS PLAN WAS PREPARED BY ME OR UNDER MY DIRECT SUPERVISION AND THAT I AM A DULY LICENSED PROFESSIONAL ENGINEER UNDER THE LAWS OF THE STATE OF MINNESOTA.

PRINT NAME: NICHOLAS DOBDA

SIGNATURE: 

DATE: 2-21-19 LICENSE NO. 49046

DRAWN BY: KT DATE: 10/24/18

DESIGN BY: JCF DATE: 10/24/18

CHECKED BY: NJD DATE: 10/24/18

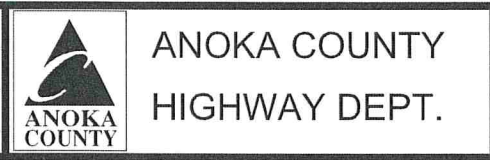

SP 002-618-032

1. GRANULAR MATERIALS MEET THE REQUIREMENTS OF MNDOT 3149.2B1
2. TOPSOIL SHALL BE DEFINED AS EXISTING SOILS WHICH MEET MN/DOT SPECIFICATION 3877 THAT WOULD BE SUITABLE FOR REUSE.
3. INPLACE TOPSOIL IS ASSUMED TO BE 4 INCHES IN DEPTH ON ALL AREAS WHERE BITUMINOUS IS NOT PRESENT.
4. FOR THIS PROJECT IT IS ASSUMED THAT ALL OTHER INPLACE SOILS MEET THE REQUIREMENTS GRANULAR MATERIAL.
5. ALL TOPSOIL STRIPPING WILL BE QUANTIFIED AS COMMON EXCAVATION. RE-PLACING THIS STRIPPED MATERIAL WILL BE INCIDENTAL TO COMMON EXCAVATION.
6. IN ALL AREAS OF NEW OR RECONSTRUCTED MAINLINE ROADWAY RECONSTRUCTION, PROVIDE FOR A MINIMUM 12 INCH COMPACTION SUBCUT UNLESS OTHERWISE NOTED. BACKFILL WITH INPLACE GRANULAR MATERIAL OR GRANULAR MATERIAL TAKEN FROM ELSEWHERE WITHIN THE PROJECT LIMITS. ANY UNCONTAMINATED SUITABLE GRANULAR MATERIAL REMOVED FROM THE EXISTING SUBGRADE AREA MAY BE USED IN OTHER AREAS DESIGNATED FOR THE SAME MATERIAL.
7. UNLESS OTHERWISE SPECIFICALLY ALLOWED OR REQUIRED BY THE CONTRACT, BITUMINOUS AND CONCRETE ITEMS DISTURBED BY CONSTRUCTION SHALL BECOME THE PROPERTY OF THE CONTRACTOR AND SHALL BE RECYCLED TO THE EXTENT ALLOWED IN BASE AND SURFACING ITEMS OR DISPOSED OF OUTSIDE THE RIGHT-OF-WAY IN ACCORDANCE WITH SPEC. 2104.3C3.
8. WHERE CONNECTING NEW SURFACING ADJACENT TO ANY INPLACE PAVEMENTS TO BE WIDENED, CUT VERTICALLY TO THE BOTTOM OF THE INPLACE SURFACING OR TO THE BOTTOM OF THE NEW SURFACING DESIGN, WHICHEVER IS DEEPER, THEN AT 1:2 SLOPE TO THE BOTTOM OF THE RECOMMENDED SUBGRADE EXCAVATION.
9. WHERE MATCHING INTO INPLACE CROSSROADS, CUT VERTICALLY TO THE BOTTOM OF THE INPLACE SURFACING OR TO THE BOTTOM OF THE NEW SURFACING DESIGN, WHICHEVER IS DEEPER, THEN AT A 1:2 TAPER TO THE BOTTOM OF THE RECOMMENDED SUBGRADE EXCAVATION.
10. USE TACK COAT BETWEEN ALL BITUMINOUS MIXTURES AND PRIOR TO PLACING ANY BITUMINOUS MIXTURES ON THE EXISTING PAVEMENT. THE BITUMINOUS TACK COAT MATERIAL SHALL BE APPLIED AT A UNIFORM RATE OF 0.03 TO 0.05 GALLONS/SQ. YD. BETWEEN BITUMINOUS LAYERS AND 0.07 TO 0.10 GALLONS/SQ. YD. ON CONCRETE OR MILLED BITUMINOUS SURFACES PRIOR TO BEING OVERLAID. THE APPLICATION RATES ARE FOR UNDILUTED EMULSIONS (AS SUPPLIED FROM THE REFINERY) OR MC AND RC LIQUID ASPHALTS. THE ASPHALT EMULSION MAY BE FURTHER DILUTED IN THE FIELD IN ACCORDANCE WITH SPECIFICATION 2357.
11. PROVIDE A SAWCUT WHERE PLACING NEW PAVEMENT ADJACENT TO INPLACE PAVEMENT TO ENSURE A UNIFORM JOINT.
12. STRIP ALL TOPSOIL AND INPLACE SLOPE DRESSING WHERE PRESENT IN AREAS TO BE DISTURBED BY CONSTRUCTION AND REUSE AS SLOPE DRESSING. FOR ESTIMATING PURPOSES, THE DEPTH OF THE INPLACE TOPSOIL AVAILABLE IS CONSIDERED TO BE 4 INCHES.
13. EMBANKMENT QUANTITIES SHOWN ON THE EARTHWORK TABULATION REPRESENT ALL EARTHWORK QUANTITIES BELOW THE TOP OF SUBGRADE. QUANTITIES REQUIRED ABOVE THE TOP OF SUBGRADE OR FOR TEMPORARY CONSTRUCTION ARE PROVIDED IN DETAIL ON THE BITUMINOUS, AGGREGATE SUMMARY, OR TEMPORARY WIDENING TABS.
14. THE CONSTRUCTION LIMITS AS SHOWN IN THE PLANS REPRESENT THE POINT OF INTERSECTION BETWEEN THE REQUIRED FILL OR CUT SLOPE AND THE EXISTING GROUND LINE AS DEPICTED ON THE CROSS SECTIONS. THE CONSTRUCTION LIMITS DO NOT INCLUDE AREAS REQUIRED FOR SLOPE ROUNDING.
15. DITCH BOTTOMS, TOE OF FILL, CUT RUNOUTS AND THE TOP EDGE OF THE BACKSLOPES SHALL BE ROUNDED REGARDLESS OF THE SECTION USED ON THE CROSS SECTION SHEETS.
16. ANY DEBRIS WHICH MAY BE ENCOUNTERED DURING GRADING SHALL BECOME PROPERTY OF THE CONTRACTOR AND DISPOSED OF OFF THE PROJECT RIGHT OF WAY IN A SUITABLE DISPOSAL AREA AS APPROVED BY THE ENGINEER.
17. UNSUITABLE SOILS NOT USED ON THE PROJECT SHALL BECOME THE PROPERTY OF THE CONTRACTOR AND REMOVED FROM THE PROJECT AND DISPOSED OF IN ACCORDANCE WITH MN/DOT SPECIFICATIONS.
18. FOR ESTIMATING PURPOSES, INPLACE BITUMINOUS PAVEMENT HAS BEEN ASSUMED TO BE 4". FOR INFORMATION ONLY, CONTRACTOR TO VERIFY PAVEMENT DEPTH PRIOR TO PLACING BID.
19. IT IS ASSUMED THAT BITUMINOUS PAVEMENT WILL BE REMOVED FROM THE PROJECT SITE AND NOT RE-USED AS EMBANKMENT.
20. AGGREGATE BASE MATERIAL SHALL MEET THE REQUIREMENTS OF MN/DOT SPEC. 3138, CLASS 5.
21. COMPACTION OF ALL AGGREGATE BASE, GRANULAR, AND SELECT GRANULAR MATERIAL SHOULD BE IN ACCORDANCE WITH MN/DOT "MODIFIED PENETRATION INDEX METHOD"
22. COMPACTION OF ALL PERMANENT BITUMINOUS MIXTURES SHALL BE THE "MAXIMUM DENSITY METHOD"
23. NO OVER-EXCAVATION WILL BE ALLOWED INSIDE THE COUNTY'S RIGHT OF WAY OF THIS PROJECT.
24. EXCESS GRANULAR MATERIAL MUST BE DEEMED EXCESS BY THE PROJECT ENGINEER PRIOR TO REMOVING IT FROM THE PROJECT.

NO	DATE	BY	CKD	APPR	REVISION
NAME: P:\002-618-032\Plan\0261832_SEQ.dgn					
01/28/2019 6:51:15 AM					

I HEREBY CERTIFY THAT THIS PLAN WAS PREPARED BY ME OR UNDER MY DIRECT SUPERVISION AND THAT I AM A DULY LICENSED PROFESSIONAL ENGINEER UNDER THE LAWS OF THE STATE OF MINNESOTA.

PRINT NAME: NICHOLAS DOBDA

SIGNATURE: *[Signature]*

DATE: 2-21-19 LICENSE NO. 49046

DRAWN BY: KT DATE: 10/24/18

DESIGN BY: JCF DATE: 10/24/18

CHECKED BY: NJD DATE: 10/24/18



ANOKA COUNTY
HIGHWAY DEPT.

SP 002-618-032

SOILS & CONSTRUCTION NOTES

Sheet 12 of 126 Sheets

EARTHWORK SUMMARY					AA
STATION	EXCAVATION		EMBANKMENT VOLUMES		
	COMMON	SUBGRADE	TOPSOIL	GRANULAR FILL	GRANULAR ROADWAY
	CY	CY	CY	CY	CY
86+00.00	32.37	20.39	13.24	22.09	33.67
86+50.00	32.38	20.85	21.34	17.00	24.47
86+69.00	31.34	27.63	6.97	12.15	18.36
87+00.00	34.24	26.63	13.66	21.26	33.72
87+50.00	38.33	25.94	26.68	31.87	40.50
87+75.00	40.46	27.55	13.61	36.10	44.37
88+00.00	36.85	27.72	10.74	20.66	45.18
88+25.00	37.81	24.34	10.91	44.09	83.43
88+50.00	43.33	19.94	13.84	60.48	98.90
89+00.00	47.03	19.59	28.91	73.81	99.98
89+50.00	48.55	18.91	31.07	71.17	85.49
90+00.00	46.12	16.07	31.99	67.33	93.29
90+50.00	43.81	18.01	30.57	54.82	67.27
90+75.00	42.27	27.64	13.19	29.10	37.46
91+00.00	46.01	37.01	9.50	11.14	28.84
91+25.00	41.48	35.53	7.48	10.23	26.96
91+50.00	32.24	31.20	7.77	9.60	25.88
92+00.00	30.94	33.00	15.36	8.55	21.90
92+50.00	51.23	38.94	9.02	1.37	20.17
92+86.00	46.50	44.40	2.21	1.19	10.68
93+00.00	26.21	37.94	0.95	1.06	13.87
93+50.00	43.12	23.01	5.14	2.90	10.50
94+00.00	45.47	15.36	10.04	5.19	5.02
94+50.00	28.20	14.88	13.06	6.55	11.14
95+00.00	22.72	13.96	15.36	13.62	13.23
95+50.00	21.74	12.29	14.66	8.35	9.92
96+00.00	21.07	10.56	14.20	13.49	15.49
96+50.00	23.72	10.15	16.75	16.42	16.02
97+00.00	31.44	12.67	12.10	5.04	5.06
97+50.00	32.42	13.86	12.56	9.74	12.68
98+00.00	27.59	18.58	17.80	14.80	20.07
98+50.00	26.62	26.59	14.09	6.09	11.66
98+69.00	32.60	28.94	6.83	11.17	15.89
99+00.00	35.81	28.35	13.51	9.91	19.70
99+50.00	26.25	27.79	14.18	5.81	15.19
100+00.00	24.84	26.28	13.31	9.54	22.81
100+50.00	27.15	24.25	15.70	10.81	21.88
101+00.00	29.34	26.70	15.51	11.36	27.17
101+50.00	31.94	28.71	16.48	14.04	33.06
102+00.00	32.67	29.16	17.34	14.49	31.94
102+50.00	36.72	30.02	17.78	15.28	33.28
103+00.00	37.84	29.44	18.94	16.79	33.19
103+50.00	34.87	29.10	19.33	16.02	32.32
104+00.00	34.27	30.05	18.43	14.03	28.84
104+35.00	40.83	37.20	9.99	6.59	21.67
104+50.00	44.33	43.20	3.18	5.49	27.54
104+75.00	37.61	46.05	4.42	2.96	13.52
SUBTOTAL (E)	1660.73	1216.37	669.68	871.55	1463.22

EARTHWORK SUMMARY					AA
STATION	EXCAVATION		EMBANKMENT VOLUMES		
	COMMON	SUBGRADE	TOPSOIL	GRANULAR FILL	GRANULAR ROADWAY
	CY	CY	CY	CY	CY
105+00.00	39.96	48.58	5.78	5.13	18.36
105+20.00	40.47	41.72	5.92	6.56	29.36
105+50.00	34.09	34.99	7.57	6.48	26.25
105+75.00	34.43	37.46	5.13	4.70	26.24
106+00.00	34.06	37.04	4.88	5.72	28.59
106+50.00	31.56	33.69	10.18	5.69	29.58
107+00.00	30.86	31.54	10.09	6.37	31.32
107+50.00	30.98	32.81	10.30	5.80	25.14
107+85.00	33.93	43.56	4.84	1.35	12.28
108+00.00	35.94	49.37	1.36	1.40	13.61
108+50.00	34.75	41.50	9.77	6.61	33.22
109+00.00	34.94	31.59	15.48	12.84	42.23
109+50.00	35.82	26.46	19.16	21.05	49.29
109+75.00	67.44	33.51	14.65	41.94	44.45
110+00.00	92.74	45.47	19.21	35.82	25.76
110+25.00	82.08	44.85	19.44	35.60	47.00
110+50.00	72.33	39.83	19.14	51.17	56.38
111+00.00	52.85	31.70	31.17	32.73	50.43
111+50.00	34.63	26.76	20.84	18.92	31.98
111+75.00	38.69	24.02	7.50	8.50	17.79
112+00.00	34.88	15.79	6.34	9.84	21.08
112+50.00	23.20	13.10	13.06	11.17	18.60
113+00.00	22.24	14.19	12.16	8.53	15.80
113+50.00	22.84	14.60	12.74	10.42	18.15
114+00.00	24.90	14.44	14.63	12.99	21.19
114+50.00	23.50	12.63	14.66	12.70	16.98
115+00.00	21.63	11.95	14.06	11.94	13.30
115+50.00	20.55	13.47	13.10	8.18	8.01
116+00.00	19.32	12.68	12.14	7.53	11.90
116+50.00	23.78	20.34	13.81	10.66	14.88
117+00.00	35.51	26.82	22.26	34.03	55.01
117+50.00	37.82	23.82	24.81	29.50	35.90
118+00.00	32.18	23.79	20.06	20.75	32.08
118+50.00	31.04	24.61	19.25	18.61	30.13
119+00.00	33.13	26.94	16.34	8.97	11.81
119+16.00	36.31	29.31	5.01	8.58	19.05
119+50.00	34.23	29.31	11.90	11.45	23.12
120+00.00	31.03	28.29	17.78	13.72	24.76
120+50.00	28.93	27.67	16.47	8.05	10.19
120+80.00	30.75	27.89	9.79	7.64	16.92
121+00.00	36.22	29.15	5.66	5.95	19.75
121+25.00	34.62	28.73	6.98	12.58	25.79
121+50.00	30.59	26.30	8.88	15.07	27.70
122+00.00	28.93	27.83	15.87	10.32	19.96
122+50.00	29.95	27.70	16.95	16.96	33.78
123+00.00	30.25	24.19	18.06	15.37	27.36
123+50.00	30.56	24.10	18.16	20.00	35.42
124+00.00	32.97	24.56	20.93	25.38	39.58
SUBTOTAL (F)	1714.40	1360.68	644.27	701.30	1287.46

EARTHWORK SUMMARY					AA
STATION	EXCAVATION		EMBANKMENT VOLUMES		
	COMMON	SUBGRADE	TOPSOIL	GRANULAR FILL	GRANULAR ROADWAY
	CY	CY	CY	CY	CY
124+25.00	33.19	25.69	10.17	19.15	24.21
124+50.00	35.50	27.56	8.14	10.93	27.60
124+75.00	35.37	26.54	8.55	20.39	35.04
125+00.00	32.79	24.86	10.38	23.42	36.71
125+50.00	32.07	24.56	20.19	21.81	34.27
125+75.00	29.95	25.68	9.07	14.64	21.52
126+00.00	26.96	27.89	6.68	6.01	16.81
126+25.00	25.33	29.36	5.19	4.75	11.25
126+50.00	24.44	23.21	6.33	6.81	18.62
127+00.00	26.18	20.86	15.39	11.46	26.35
127+50.00	28.81	26.27	16.56	12.60	21.21
128+00.00	28.71	25.94	16.56	11.78	24.98
128+50.00	27.14	26.44	14.81	9.24	19.06
129+00.00	25.89	28.32	13.35	8.19	20.08
129+50.00	26.95	27.08	14.97	11.67	24.66
130+00.00	28.76	24.69	17.44	14.54	26.02
130+50.00	32.10	24.90	20.54	19.89	29.55
131+00.00	33.26	25.88	21.47	18.74	29.71
131+50.00	32.91	24.29	21.55	24.11	37.22
132+00.00	35.03	24.22	23.74	29.66	39.77
132+50.00	30.50	20.05	18.11	10.29	12.26
133+00.00	26.48	12.20	14.48	14.59	18.72
133+20.00	26.34	9.39	6.69	18.72	18.12
133+50.00	25.00	9.62	10.09	20.82	19.86
134+00.00	25.21	10.27	17.23	19.85	17.33
134+50.00	23.25	11.55	15.46	12.15	10.46
134+80.00	22.29	12.60	8.58	12.49	16.64
135+00.00	22.19	12.56	5.72	13.68	14.69
135+50.00	20.28	12.47	13.44	10.52	11.13
136+00.00	17.17	12.70	10.44	4.81	8.31
136+25.00	14.77	14.06	3.73	3.27	6.51
136+50.00	17.21	15.60	2.83	1.73	6.35
136+75.00	17.69	15.44	3.17	3.40	6.55
137+00.00	16.72	14.77	4.31	3.64	6.59
139+00.00	13.77	15.25	25.30	1.32	4.45
SUBTOTAL (G)	920.22	712.78	440.67	451.11	702.60
PROJECT TOT.	10128.69	7803.75	4035.51	4252.27	7565.57

1	04/22/2019	OFF	JF	NJD	REVISED QUANTITIES
NO	DATE	BY	CKD	APPR	REVISION
NAME: P:\002-618-032\Plan\0261832_SEQ.dgn 04/22/2019 12:48:35 PM					

I HEREBY CERTIFY THAT THIS PLAN WAS PREPARED BY ME OR UNDER MY DIRECT SUPERVISION AND THAT I AM A DULY LICENSED PROFESSIONAL ENGINEER UNDER THE LAWS OF THE STATE OF MINNESOTA.
 PRINT NAME: NICHOLAS DOBDA
 SIGNATURE: 
 DATE: 4/22/19 LICENSE NO. 49046

DRAWN BY: KT DATE: 10/24/18
 DESIGN BY: JCF DATE: 10/24/18
 CHECKED BY: NJD DATE: 10/24/18

 ANOKA COUNTY
HIGHWAY DEPT.

SP 002-618-032
 TABULATIONS
 Sheet 14 of 126 Sheets

EARTHWORK TABULATION TOTAL				BB	
	EXCAVATION TOTALS		EMBANKMENT VOLUMES		
	COMMON	SUBGRADE	TOPSOIL	GRANULAR FILL	GRANULAR ROADWAY
	CY	CY	CY	CY	CY
PROJECT TOTAL	10,129	7,804	4,036	4,252	7,566

EARTHWORK BALANCE										CC								
AVAILABLE EXCAVATION (CUBIC YARDS)																		
COMMON (EV)		10,129	EXISTING TOPSOIL		8,052	(EV) /	1.2	=	6,710	(CV)	<table border="1"> <thead> <tr> <th colspan="2">PAY ITEMS</th> </tr> </thead> <tbody> <tr> <td>TOTAL COMMON EXCAVATION</td> <td>10,129</td> </tr> <tr> <td>TOAL SUBGRADE EXCAVATION</td> <td>7,804</td> </tr> </tbody> </table>		PAY ITEMS		TOTAL COMMON EXCAVATION	10,129	TOAL SUBGRADE EXCAVATION	7,804
PAY ITEMS																		
TOTAL COMMON EXCAVATION	10,129																	
TOAL SUBGRADE EXCAVATION	7,804																	
SUBGRADE EXCAVATION (EV)		7,804	GRANULAR FILL		2,077	(EV) /	1.2	=	1,730	(CV)								
			GRANULAR SUBGRADE		7,804	(EV) /	1.2	=	6,503	(CV)								
NEEDED EMBANKMENT (CUBIC YARDS)																		
			TOPSOIL		4,036	(CV)	(SCREENED PRIOR TO PLACEMENT)											
			GRANULAR FILL		4,252	(CV)												
			GRANULAR ROADWAY		7,566	(CV)												
EXCESS QUANTITIES (CUBIC YARDS)																		
			<u>AVAILABLE</u>		<u>NEEDED</u>		<u>EXCESS</u>											
TOPSOIL		6,710	(CV)	-	4,036	(CV)	=	2,674	(CV)									
BORROW QUANTITIES (CUBIC YARDS)																		
			<u>AVAILABLE</u>		<u>NEEDED</u>		<u>BORROW</u>											
GRANULAR FILL		1,730	(CV)	-	4,252	(CV)	=	2,522	(CV)	3,585 (CV)								
GRANULAR SUBGRADE		6,503	(CV)	-	7,566	(CV)	=	1,063	(CV)									

NO	DATE	BY	CKD	APPR	REVISION
1	04/22/2019	DFD	JF	NJD	REVISED QUANTITIES

I HEREBY CERTIFY THAT THIS PLAN WAS PREPARED BY ME OR UNDER MY DIRECT SUPERVISION AND THAT I AM A DULY LICENSED PROFESSIONAL ENGINEER UNDER THE LAWS OF THE STATE OF MINNESOTA.
 PRINT NAME: NICHOLAS DOBDA
 SIGNATURE: *[Signature]*
 DATE: 4/22/19 LICENSE NO. 49046

DRAWN BY: KT DATE: 10/24/18
 DESIGN BY: JCF DATE: 10/24/18
 CHECKED BY: NJD DATE: 10/24/18



ANOKA COUNTY
 HIGHWAY DEPT.

SP 002-618-032

C.S.A.H. 18 (BROADWAY AVE.) EXISTING TYP. SECTION

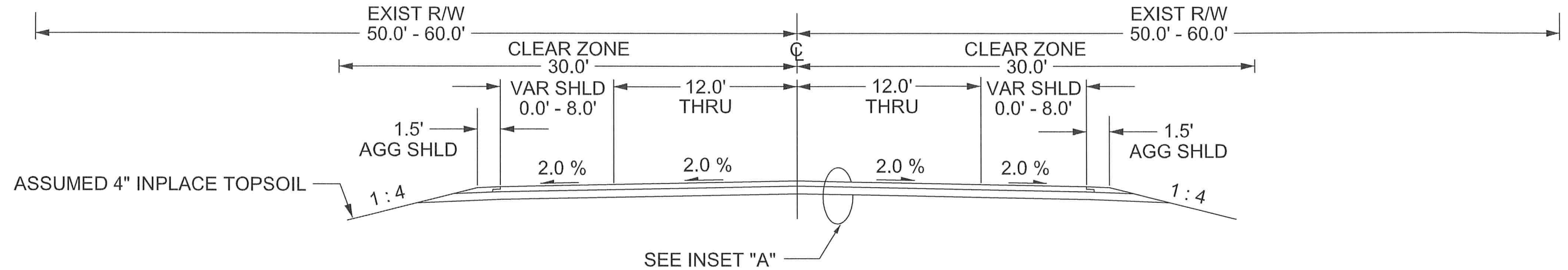

C.S.A.H. 18 (BROADWAY AVE.) EXISTING TYP. RTL

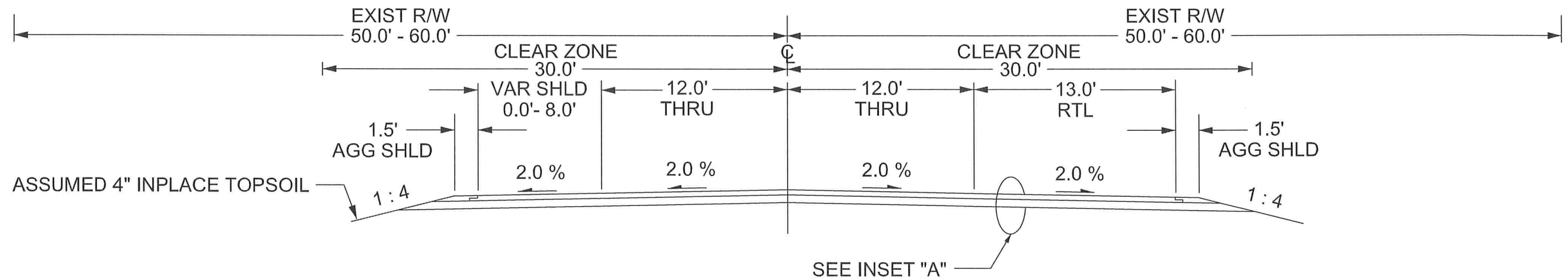

INSET "A" [1]

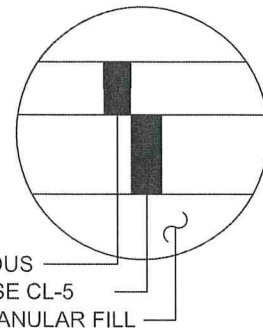

INPLACE 4.0" BITUMINOUS
INPLACE AGGREGATE BASE CL-5
INPLACE GRANULAR FILL

[1] FOR REFERENCE ONLY, CONTRACTOR TO VERIFY PRIOR TO PLACING BID

NO	DATE	BY	CKD	APPR	REVISION

NAME: P:\002-618-032\Plan\0261832_TYP_P1.dgn 01/28/2019 6:51:41 AM

I HEREBY CERTIFY THAT THIS PLAN WAS PREPARED BY ME OR UNDER MY DIRECT SUPERVISION AND THAT I AM A DULY LICENSED PROFESSIONAL ENGINEER UNDER THE LAWS OF THE STATE OF MINNESOTA.
PRINT NAME: NICHOLAS DOBDA
SIGNATURE: *Nicholas Dobda*
DATE: 2-21-19 LICENSE NO. 49046

DRAWN BY: KCR DATE: 5/24/17
DESIGN BY: KCR DATE: 5/24/17
CHECKED BY: NJD DATE: 5/24/17



ANOKA COUNTY
HIGHWAY DEPT.

SP 002-618-032

EXISTING
TYPICAL SECTION

Sheet 16 of 126 Sheets

C.S.A.H. 18 (BROADWAY AVE.) PROPOSED TYP. SECTION

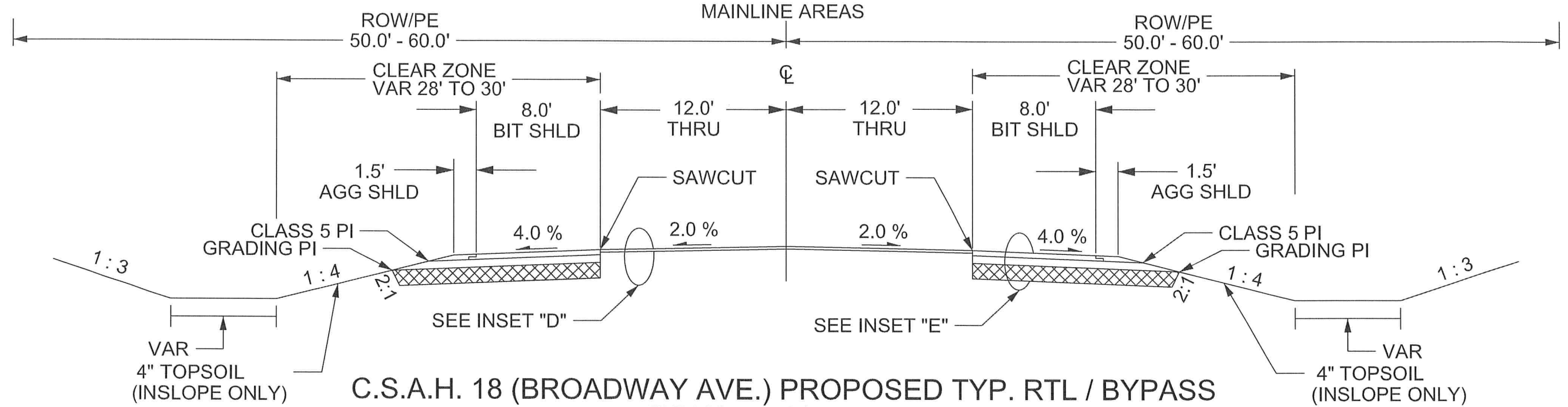

C.S.A.H. 18 (BROADWAY AVE.) PROPOSED TYP. RTL / BYPASS

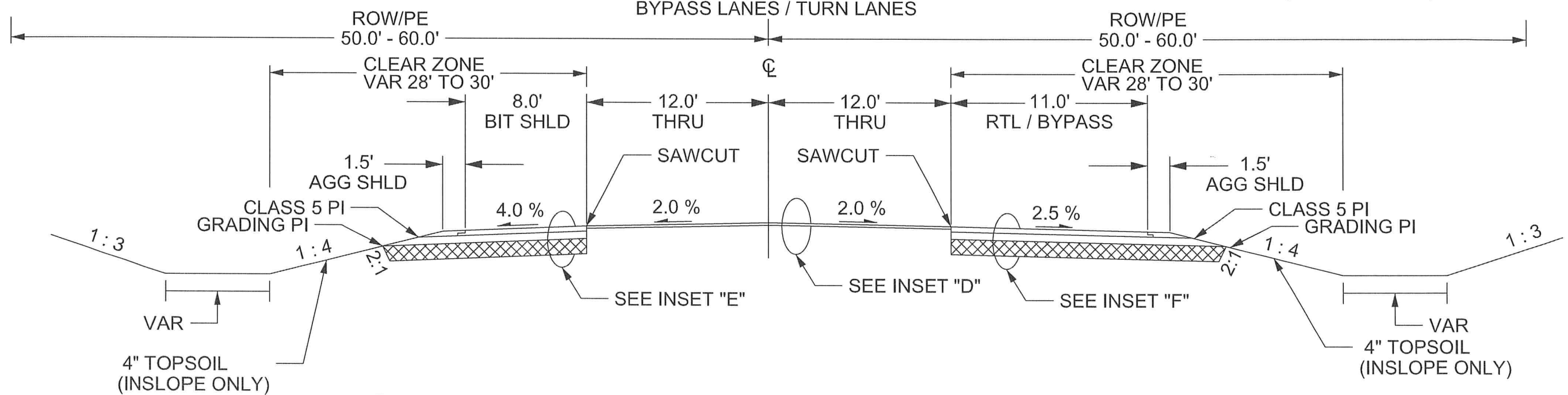

INSET "D"

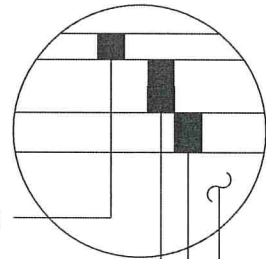

2.0" TYPE SP 12.5 WEARING COURSE (SPWEB340C)

4.0" INPLACE BITUMINOUS
INPLACE AGGREGATE BASE
INPLACE GRANULAR FILL

INSET "E"

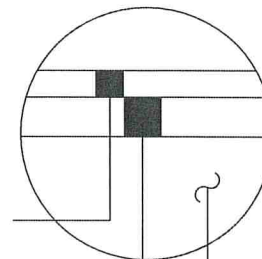

2.0" TYPE SP 12.5 WEARING COURSE (SPWEB340C)

6.0" AGGREGATE BASE CL-5
VARIABLE DEPTH GRANULAR FILL

INSET "F"

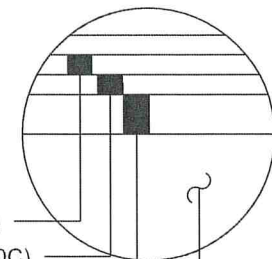

2.0" TYPE SP 12.5 WEARING COURSE (SPWEB340C)
2.0" TYPE SP 12.5 WEARING COURSE (SPWEB340C)

6.0" AGGREGATE BASE CL-5
VARIABLE DEPTH GRANULAR FILL

NO	DATE	BY	CKD	APPR	REVISION

NAME: P:\002-618-032\Plan\0261832_TYP_P1.dgn 01/28/2019 6:51:41 AM

I HEREBY CERTIFY THAT THIS PLAN WAS PREPARED BY ME OR UNDER MY DIRECT SUPERVISION AND THAT I AM A DULY LICENSED PROFESSIONAL ENGINEER UNDER THE LAWS OF THE STATE OF MINNESOTA.
 PRINT NAME: NICHOLAS DOBDA
 SIGNATURE: *N. Dobda*
 DATE: 2-21-19 LICENSE NO. 49046

DRAWN BY: KCR DATE: 5/24/17
 DESIGN BY: DATE: 5/24/17
 CHECKED BY: NJD DATE: 5/24/17



ANOKA COUNTY
HIGHWAY DEPT.

SP 002-618-032

PROPOSED
TYPICAL SECTION

MAINLINE JOINT DETAIL (OVERLAY)

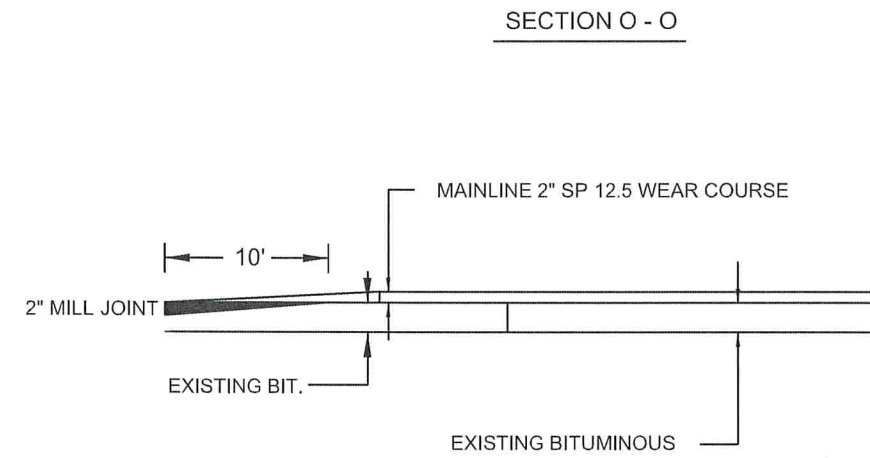
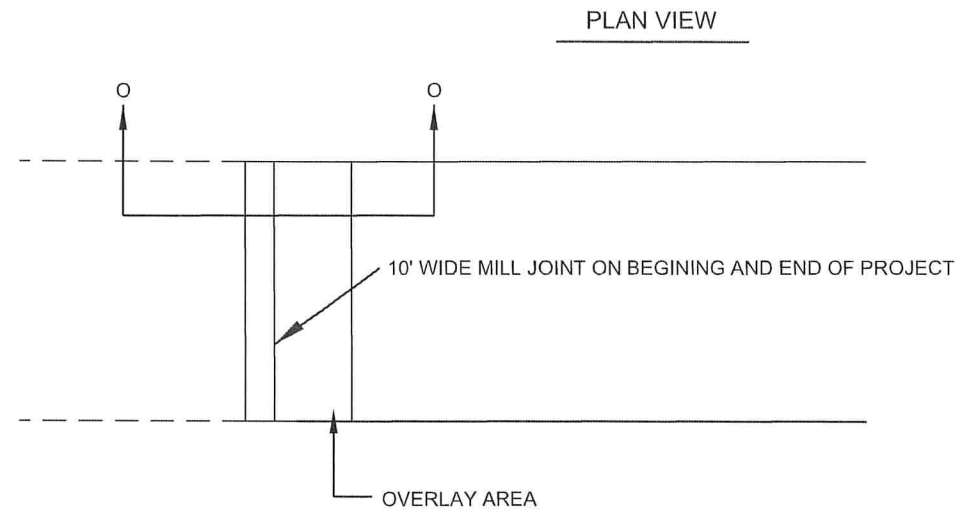

SHOULDER DETAIL

BITUMINOUS SAFETY EDGE
GRAVEL SHOULDER

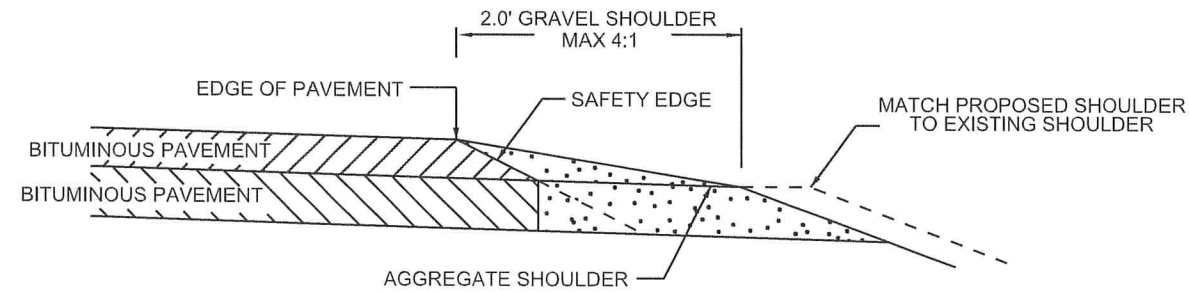

SAFETY EDGE TO BE USED IN ALL NON-CURB AREAS ON SHOULDER.

OPTIONAL DESIGN EXTENDS SAFETY EDGE DEEPER
THAN 6" AND WIDER THAN 10.5". SEE SPECIAL PROVISIONS .

NO	DATE	BY	CKD	APPR	REVISION

NAME: P:\002-618-032\Plan\0261832_MD.dgn 01/28/2019 6:51:43 AM

I HEREBY CERTIFY THAT THIS PLAN WAS PREPARED BY ME OR UNDER MY DIRECT SUPERVISION AND THAT I AM A DULY LICENSED PROFESSIONAL ENGINEER UNDER THE LAWS OF THE STATE OF MINNESOTA.

PRINT NAME: NICHOLAS DOBDA

SIGNATURE: *Nicholas Dobda*

DATE: 2-21-19 LICENSE NO. 49046

DRAWN BY: KT DATE: 10/24/18

DESIGN BY: JCF DATE: 10/24/18

CHECKED BY: NJD DATE: 10/24/18



**ANOKA COUNTY
HIGHWAY DEPT.**

SP 002-618-032

DETAILS

STREET APPROACH DETAIL (OVERLAY)

BITUMINOUS STREET

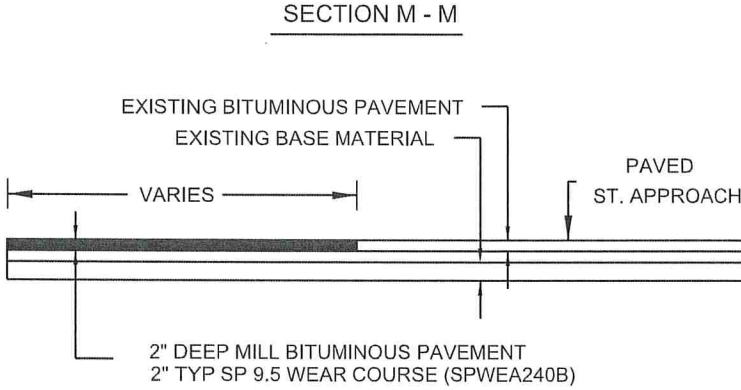
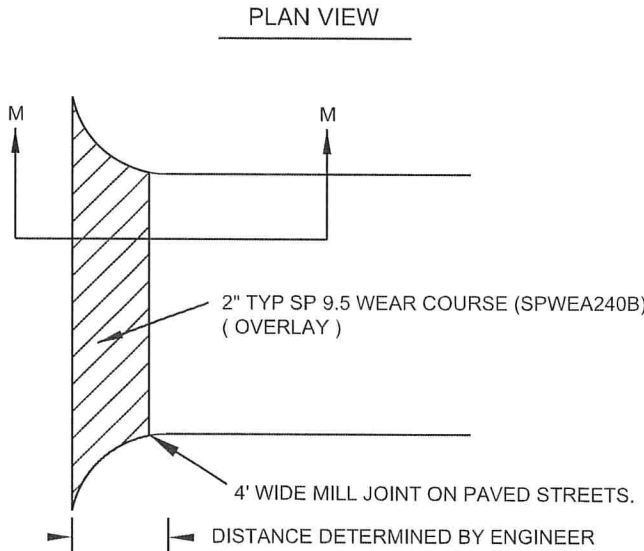

STREET APPROACH DETAIL (RE-CONSTRUCT)

BITUMINOUS STREET

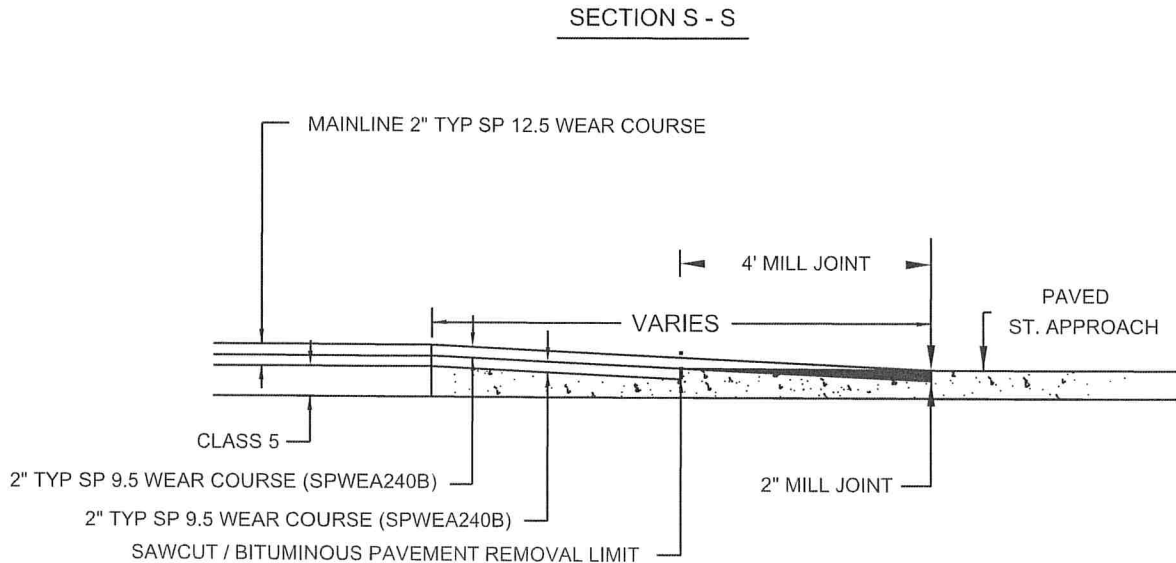
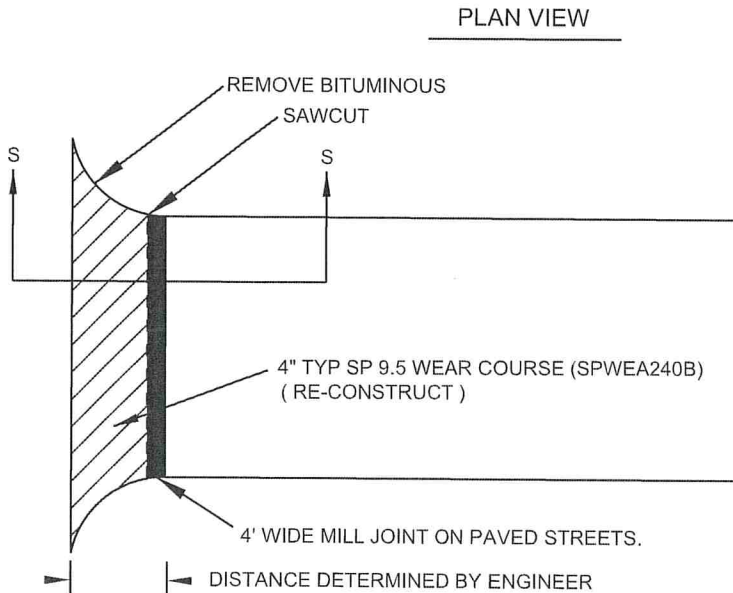

NO	DATE	BY	CKD	APPR	REVISION

I HEREBY CERTIFY THAT THIS PLAN WAS PREPARED BY ME OR UNDER MY DIRECT SUPERVISION AND THAT I AM A DULY LICENSED PROFESSIONAL ENGINEER UNDER THE LAWS OF THE STATE OF MINNESOTA.

PRINT NAME: NICHOLAS DOBDA

SIGNATURE: *Nicholas Dobda*

DATE: 2-21-19 LICENSE NO. 49046

DRAWN BY: KT DATE: 10/24/18

DESIGN BY: JCF DATE: 10/24/18

CHECKED BY: NJD DATE: 10/24/18



**ANOKA COUNTY
HIGHWAY DEPT.**

SP 002-618-032

BITUMINOUS DRIVEWAY DETAIL

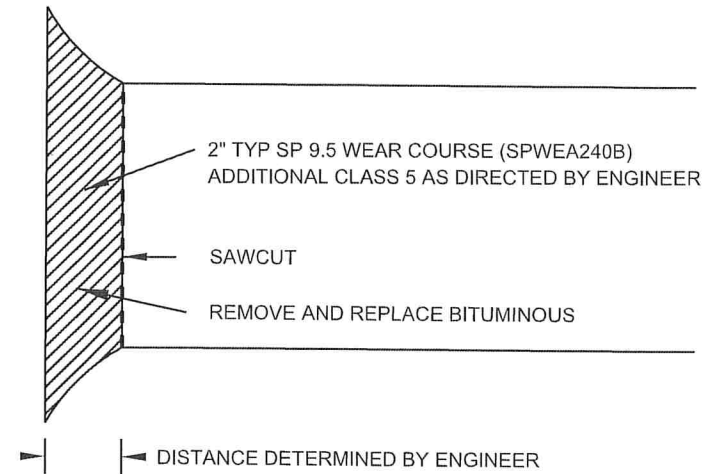

NOTE:
 CONTRACTOR TO CONTACT PROPERTY OWNER IN ADVANCE PRIOR TO DRIVEWAY
 REMOVAL, CONSTRUCTION, CULVERT REPLACEMENT AND MAILBOX RELOCATION.

GRAVEL DRIVEWAY / FIELD ENTRANCE DETAIL

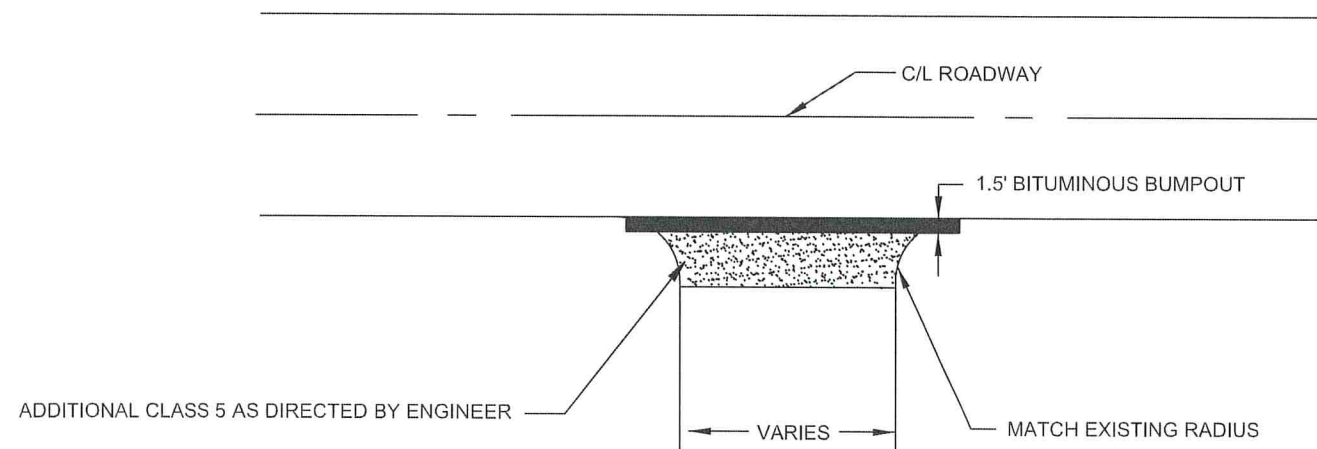

CONCRETE DRIVEWAY DETAIL

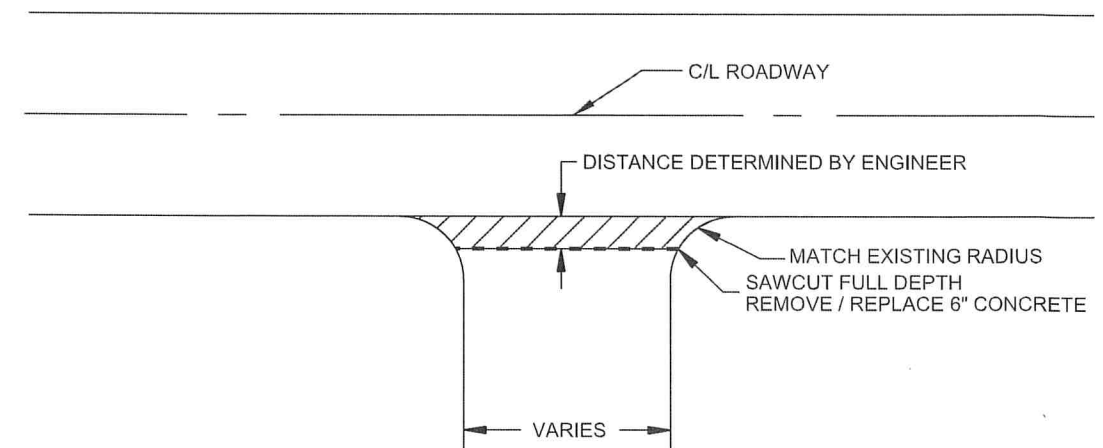

NO	DATE	BY	CKD	APPR	REVISION

NAME: P:\002-618-032\Plan\0261832_MD.dgn 01/28/2019 6:51:43 AM

I HEREBY CERTIFY THAT THIS PLAN WAS PREPARED BY ME OR UNDER MY DIRECT SUPERVISION AND THAT I AM A DULY LICENSED PROFESSIONAL ENGINEER UNDER THE LAWS OF THE STATE OF MINNESOTA.
 PRINT NAME: NICHOLAS DOBDA
 SIGNATURE: *Nicholas Dobda*
 DATE: 2-21-19 LICENSE NO. 49046

DRAWN BY KT DATE 10/24/18
 DESIGN BY JCF DATE 10/24/18
 CHECKED BY NJD DATE 10/24/18



ANOKA COUNTY
 HIGHWAY DEPT.

SP 002-618-032

DETAILS

RIGHT TURN AND BYPASS LANE

GENERAL LAYOUT PLAN VIEW

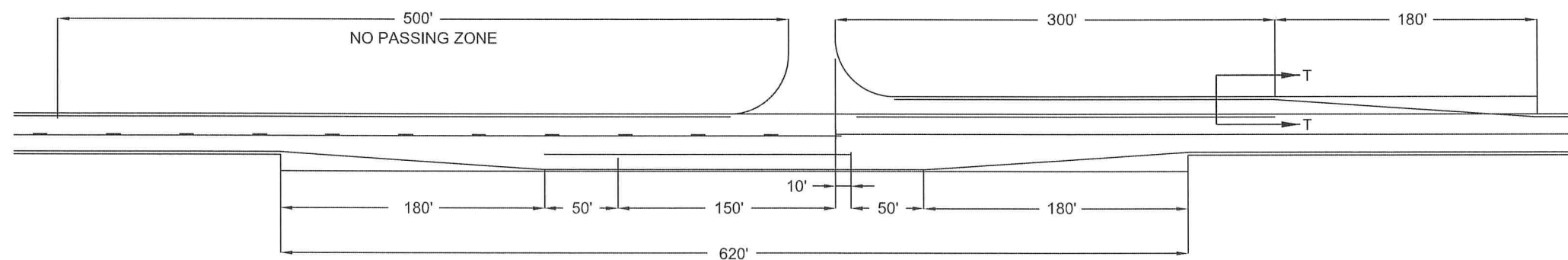

NO	DATE	BY	CKD	APPR	REVISION

NAME: P:\002-618-032\Plan\0261832_MD.dgn 01/28/2019 6:51:43 AM

I HEREBY CERTIFY THAT THIS PLAN WAS PREPARED BY ME OR UNDER MY DIRECT SUPERVISION AND THAT I AM A DULY LICENSED PROFESSIONAL ENGINEER UNDER THE LAWS OF THE STATE OF MINNESOTA.

PRINT NAME: NICHOLAS DOBDA

SIGNATURE: *Nicholas Dobda*

DATE: 2-21-19 LICENSE NO. 49046

DRAWN BY: KT DATE: 10/24/18

DESIGN BY: JCF DATE: 10/24/18

CHECKED BY: NJD DATE: 10/24/18

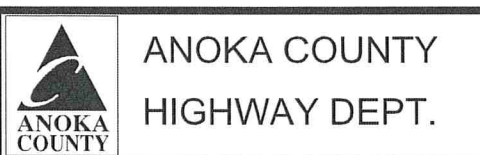

SP 002-618-032

DETAILS

Sheet 21 of 126 Sheets

TABLE OF QUANTITIES
RIPRAP AT RCP OUTLETS

DIA. OF ROUND PIPE (IN.)	L (FT.)	CLASS II d ₅₀ = 6"			CLASS III d ₅₀ = 9"			CLASS IV d ₅₀ = 12"		
		GEO-TEXTILE FILTER (SQ. YD.)	GRANULAR FILTER UNDER APRON (CU. YD.)	12" DEPTH RIPRAP (CU. YD.)	GEO-TEXTILE FILTER (SQ. YD.)	GRANULAR FILTER UNDER APRON (CU. YD.)	18" DEPTH RIPRAP (CU. YD.)	GEO-TEXTILE FILTER (SQ. YD.)	GRANULAR FILTER UNDER APRON (CU. YD.)	24" DEPTH RIPRAP (CU. YD.)
12	8	16.9	0.2	3.0	19.6	0.3	4.4	22.6	0.3	5.9
15	8	18.0	0.2	3.2	20.8	0.3	4.8	23.9	0.4	6.4
18	10	22.4	0.3	4.3	25.6	0.4	6.4	29.0	0.5	8.5
21	10	24.1	0.4	4.7	27.4	0.6	7.1	30.9	0.7	9.4
24	12	29.7	0.5	6.2	33.4	0.8	9.2	37.3	1.0	12.3
27	12	31.4	0.6	6.6	35.2	0.9	9.9	39.2	1.2	13.2
30	14	37.4	0.8	8.2	41.6	1.1	12.3	46.0	1.5	16.4
36	16	45.9	1.1	10.6	50.5	1.6	15.8	55.4	2.1	21.1
42	18	52.8	1.2	12.5	57.8	1.7	18.7	63.0	2.3	24.9
48	20	61.1	1.5	14.8	66.5	2.2	22.2	72.0	2.9	29.6

TABLE OF QUANTITIES
RIPRAP AT RCP-A OUTLETS

SPAN OF PIPE ARCH (IN.)	L (FT.)	CLASS II d ₅₀ = 6"			CLASS III d ₅₀ = 9"			CLASS IV d ₅₀ = 12"		
		GEO-TEXTILE FILTER (SQ. YD.)	GRANULAR FILTER UNDER APRON (CU. YD.)	12" DEPTH RIPRAP (CU. YD.)	GEO-TEXTILE FILTER (SQ. YD.)	GRANULAR FILTER UNDER APRON (CU. YD.)	18" DEPTH RIPRAP (CU. YD.)	GEO-TEXTILE FILTER (SQ. YD.)	GRANULAR FILTER UNDER APRON (CU. YD.)	24" DEPTH RIPRAP (CU. YD.)
22	10	22.4	0.3	4.1	25.6	0.4	6.1	29.0	0.5	8.1
28	12	29.5	0.5	5.7	33.2	0.7	8.5	37.1	0.9	11.3
36	14	37.3	0.8	7.5	41.5	1.1	11.2	45.8	1.5	14.9
43	16	45.9	1.1	9.5	50.5	1.6	14.3	55.3	2.1	19.0
51	18	52.5	1.2	11.3	57.5	1.7	16.9	62.7	2.3	22.5
58	20	59.9	1.3	13.2	65.2	1.9	19.8	70.7	2.5	26.4

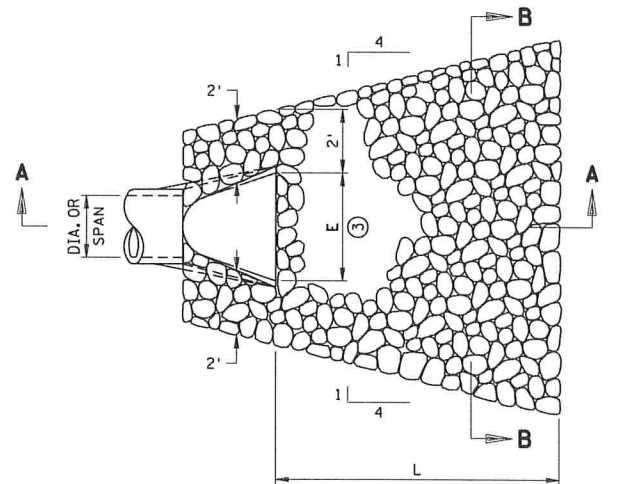

PLAN

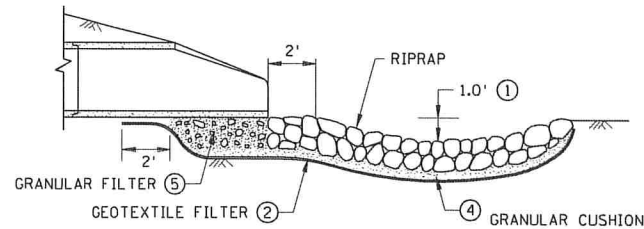

SECTION A-A

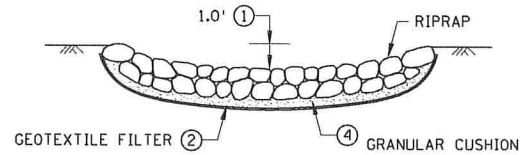

SECTION B-B

NOTES:

- REQUIREMENTS FOR GEOTEXTILE TYPE, RIPRAP SIZE AND THICKNESS WILL BE DESIGNATED IN THE PLANS.
- PIPE SIZES LARGER THAN THOSE SHOWN REQUIRE A SPECIAL DESIGN.
- ① FOR PIPES GREATER THAN OR EQUAL TO 30", USE 1.5'.
- ② GEOTEXTILE FILTER, SPEC. 3733, SHALL COVER THE BOTTOM AND SIDES OF THE AREA EXCAVATED FOR THE RIPRAP, GRANULAR FILTER MATERIALS.
- ③ DIMENSION E IS GIVEN ON STANDARD PLATES 3100 AND 3110.
- ④ GRANULAR FILTER, SPEC. 3601, MAY BE USED AS A CUSHION LAYER. PLACE FILTER PER SPEC. 2511. THE CUSHION LAYER IS INCIDENTAL.
- ⑤ GRANULAR FILTER OR RIPRAP, SPEC. 3601, TO EXTEND UNDER ENTIRE OPEN PORTION OF PIPE APRON. DEPTH OF MATERIAL UNDER APRON SHALL MATCH RIPRAP DEPTH. WHEN USING RIPRAP INCREASE RIPRAP QUANTITY ACCORDINGLY AND PLACE A 3" LAYER OF 1.5" CRUSHED ROCK UNDER THE APRON TO AID IN GRADING FOR APRON PLACEMENT. CRUSHED ROCK IS INCIDENTAL.

APPROVED DECEMBER 9, 2013

Christopher Ky
STATE DESIGN ENGINEER

STATE OF MINNESOTA
DEPARTMENT OF TRANSPORTATION

RIPRAP AT RCP OUTLETS

SPECIFICATION REFERENCE
3100
3110
3601
3733
2511

STANDARD PLATE NO.
3133D

TABLE OF QUANTITIES
RIPRAP AT CSP OUTLETS

DIA. OF ROUND PIPE (IN.)	L (FT.)	CLASS II d ₅₀ = 6"			CLASS III d ₅₀ = 9"			CLASS IV d ₅₀ = 12"		
		GEO-TEXTILE FILTER (SQ. YD.)	GRANULAR FILTER UNDER APRON (CU. YD.)	12" DEPTH RIPRAP (CU. YD.)	GEO-TEXTILE FILTER (SQ. YD.)	GRANULAR FILTER UNDER APRON (CU. YD.)	18" DEPTH RIPRAP (CU. YD.)	GEO-TEXTILE FILTER (SQ. YD.)	GRANULAR FILTER UNDER APRON (CU. YD.)	24" DEPTH RIPRAP (CU. YD.)
12	8	16.4	0.2	3.0	19.2	0.2	4.5	22.3	0.3	6.0
15	8	17.8	0.2	3.3	20.7	0.3	4.9	23.9	0.4	6.6
18	10	22.9	0.3	4.6	26.2	0.5	6.8	29.7	0.6	9.1
21	10	24.5	0.4	4.9	27.9	0.6	7.3	31.5	0.8	9.7
24	12	30.4	0.5	6.4	34.2	0.8	9.5	38.2	1.0	12.7
30	14	38.9	0.8	8.5	43.2	1.2	12.7	47.7	1.5	16.9
36	16	48.3	1.1	10.8	53.1	1.6	16.2	58.1	2.1	21.6
42	18	58.7	1.5	13.5	64.0	2.2	20.2	69.5	2.9	27.0
48	20	68.5	1.8	16.0	74.2	2.7	24.0	80.1	3.5	32.0

TABLE OF QUANTITIES
RIPRAP AT CSP-A OUTLETS

SPAN OF PIPE ARCH (IN.)	L (FT.)	CLASS II d ₅₀ = 6"			CLASS III d ₅₀ = 9"			CLASS IV d ₅₀ = 12"		
		GEO-TEXTILE FILTER (SQ. YD.)	GRANULAR FILTER UNDER APRON (CU. YD.)	12" DEPTH RIPRAP (CU. YD.)	GEO-TEXTILE FILTER (SQ. YD.)	GRANULAR FILTER UNDER APRON (CU. YD.)	18" DEPTH RIPRAP (CU. YD.)	GEO-TEXTILE FILTER (SQ. YD.)	GRANULAR FILTER UNDER APRON (CU. YD.)	24" DEPTH RIPRAP (CU. YD.)
17	8	18.7	0.2	3.1	20.1	0.3	4.7	23.2	0.3	6.3
21	10	21.9	0.3	4.5	25.1	0.4	6.7	28.6	0.5	9.0
24	10	23.5	0.3	4.9	26.8	0.5	7.4	30.4	0.6	9.8
28	12	29.2	0.4	6.4	32.9	0.6	9.6	36.8	0.8	12.9
35	14	36.8	0.6	8.5	41.0	0.9	12.8	45.4	1.2	17.1
42	16	46.5	0.9	11.2	51.1	1.3	16.8	56.0	1.7	22.5
49	18	55.5	1.1	13.8	60.6	1.7	20.7	66.0	2.2	27.6
57	20	66.6	1.5	17.0	72.2	2.3	25.5	78.0	3.0	34.0

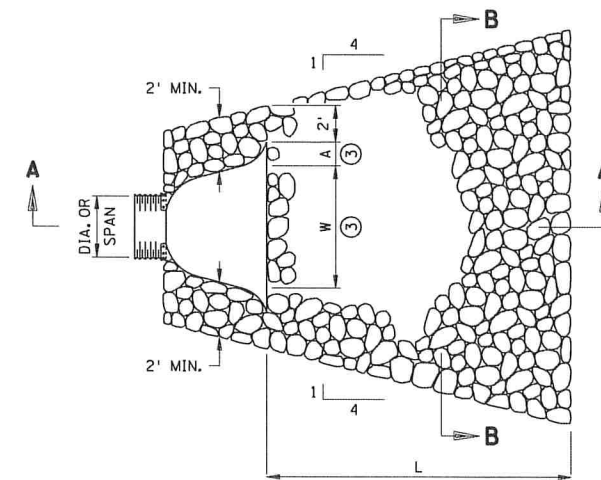

PLAN

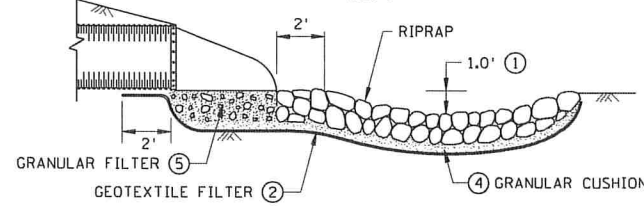

SECTION A-A

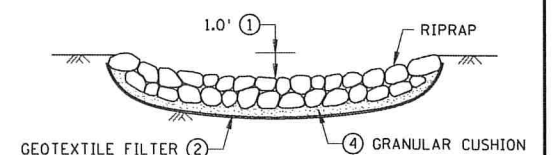

SECTION B-B

NOTES:

- REQUIREMENTS FOR GEOTEXTILE TYPE, RIPRAP SIZE AND THICKNESS SHALL BE DESIGNATED IN THE PLANS.
- PIPE SIZES LARGER THAN THOSE SHOWN REQUIRE A SPECIAL DESIGN.
- ① FOR PIPES GREATER THAN OR EQUAL TO 30", USE 1.5'.
- ② GEOTEXTILE FILTER, SPEC. 3733, SHALL COVER THE BOTTOM AND SIDES OF THE AREA EXCAVATED FOR THE RIPRAP, GRANULAR FILTER MATERIALS.
- ③ DIMENSIONS W AND A ARE GIVEN ON STANDARD PLATES 3122 AND 3123.
- ④ GRANULAR FILTER, SPEC. 3601, MAY BE USED AS A CUSHION LAYER. PLACE FILTER PER SPEC. 2511. THE CUSHION LAYER IS INCIDENTAL.
- ⑤ GRANULAR FILTER OR RIPRAP, SPEC. 3601, TO EXTEND UNDER ENTIRE OPEN PORTION OF PIPE APRON. DEPTH OF MATERIAL UNDER APRON SHALL MATCH RIPRAP DEPTH. WHEN USING RIPRAP INCREASE RIPRAP QUANTITY ACCORDINGLY AND PLACE A 3" LAYER OF 1.5" CRUSHED ROCK UNDER THE APRON TO AID IN GRADING FOR APRON PLACEMENT. CRUSHED ROCK IS INCIDENTAL.

APPROVED DECEMBER 9, 2013

Christopher Ky
STATE DESIGN ENGINEER

STATE OF MINNESOTA
DEPARTMENT OF TRANSPORTATION

RIPRAP AT CSP OUTLETS

SPECIFICATION REFERENCE
3123
3122
3601
3733
2511

STANDARD PLATE NO.
3134D

NO	DATE	BY	CKD	APPR	REVISION

NAME: P:\002-618-032\Plan\0261832_MD.dgn 01/28/2019 6:51:43 AM

I HEREBY CERTIFY THAT THIS PLAN WAS PREPARED BY ME OR UNDER MY DIRECT SUPERVISION AND THAT I AM A DULY LICENSED PROFESSIONAL ENGINEER UNDER THE LAWS OF THE STATE OF MINNESOTA.
PRINT NAME: NICHOLAS DOBDA
SIGNATURE: *Nicholas Dobda*
DATE: 2-21-19 LICENSE NO. 49046

DRAWN BY: KT DATE: 10/24/18
DESIGN BY: JCF DATE: 10/24/18
CHECKED BY: NJD DATE: 10/24/18



ANOKA COUNTY
HIGHWAY DEPT.

SP 002-618-032

DETAILS

- NOTES:
 1 TEMPORARY TRAFFIC CONTROL DEVICE
 2 INPLACE SIGN TO BE TEMPED DURING CONSTRUCTION ACTIVITIES

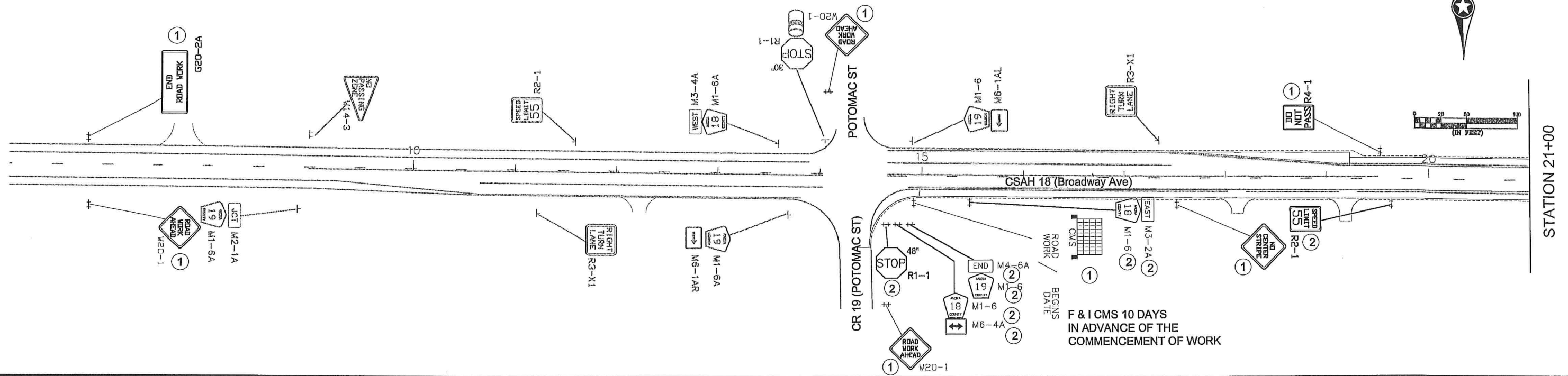

- NOTES:
- ALL TRAFFIC CONTROL DEVICES SHALL CONFORM AND BE PLACED IN ACCORDANCE WITH THE CURRENT "MINNESOTA MANUAL ON UNIFORM TRAFFIC CONTROL DEVICES" (MN MUTCD), INCLUDING PART VI, "FIELD MANUAL FOR TEMPORARY TRAFFIC CONTROL ZONE LAYOUTS".
 - UTILIZE FIELD MANUAL LAYOUT 16 DURING DAYTIME CONSTRUCTION OPERATIONS, AND RETURN TO NON-ACTIVE WORK ZONE TYPICAL AT CONCLUSION OF EACH WORK DAY (SEE SHEET 30).
 - CONTRACTOR SHALL SUPPLY AND INSTALL THE PORTABLE CHANGEABLE MESSAGE SIGN (CMS) A MINIMUM 10 DAYS PRIOR TO ACTUAL COMMENCEMENT OF ROAD WORK, TO A LOCATION AS SPECIFIED BY THE ENGINEER. SIGNS TO BE REMOVED WHEN ROAD WORK BEGINS. PAYMENT SHALL BE MADE AS PER ITEM 2563.613 PORTABLE CHANGEABLE MESSAGE SIGN BY THE UNIT/DAY.
 - CONTRACTOR SHALL COMPLY WITH THE LONGITUDINAL DROP-OFF GUIDELINES AS PER THE MN MUTCD.
 - CONTRACTOR SHALL SUPPLY, ERECT AND MAINTAIN THE TEMPORARY TRAFFIC CONTROL SIGNS AS SHOWN ON THIS DRAWING AND DETAILED IN THE SPECIAL PROVISIONS FROM THE TIME WORK COMMENCES ON THIS ROADWAY UNTIL THIS ROADWAY IS PERMANENTLY STRIPED. ALL NECESSARY TEMPORARY TRAFFIC CONTROL SIGNS SHALL BE PAID FOR AS PART OF TRAFFIC CONTROL LUMP SUM.
 - ALL INPLACE SIGNS THAT ARE TO BE TEMPED SHALL REMAIN IN PRISTINE CONDITION UNTIL REINSTALLED. SHALL BE PAID BY THE EACH ASSEMBLY WHEN REINSTALLATION IS REQUIRED.
 - ALL PERMANENT STRIPING AND PAVEMENT MESSAGES SHALL BE PLACED WITHIN 72 HOURS OF MAINLINE PAVING.

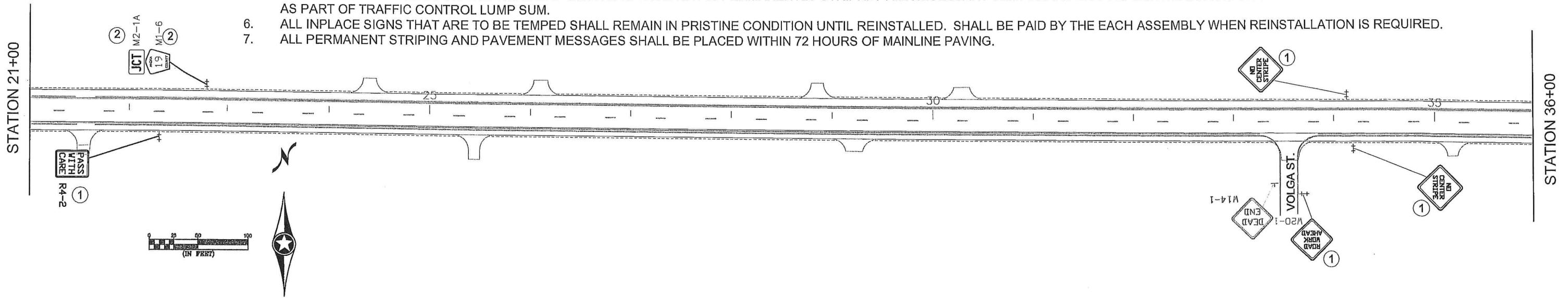

I HEREBY CERTIFY THAT THIS PLAN WAS PREPARED BY ME OR UNDER MY DIRECT SUPERVISION AND THAT I AM A DULY LICENSED PROFESSIONAL ENGINEER UNDER THE LAWS OF THE STATE OF MINNESOTA.
 PRINT NAME: DOUGLAS W. FISCHER
 SIGNATURE: *[Signature]*
 DATE: 2/25/19 LICENSE NO. 20235

DRAWN BY: TV DATE: 09/19/18
 DESIGN BY: DATE: _____
 CHECKED BY: DATE: _____



ANOKA COUNTY
 HIGHWAY DEPT.

STATE PROJECT NO. 002-618-032
 STATE AID PROJECT NO. _____
 CITY PROJECT NO. _____
 COUNTY PROJECT NO. _____

TRAFFIC CONTROL
 PLAN

NO	DATE	BY	CKD	APPR	REVISION

NAME: P/02-618-032/Base/Traffic/Existing S&S

NOTES:

- 1 TEMPORARY TRAFFIC CONTROL DEVICE
- 2 INPLACE SIGN TO BE TEMPED DURING CONSTRUCTION ACTIVITES



STATION 36+00

STATION 51+00

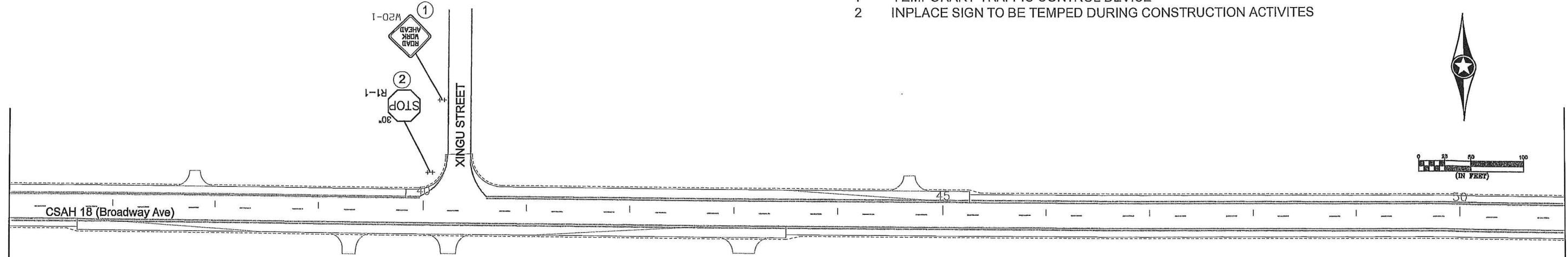

NOTES:

1. ALL TRAFFIC CONTROL DEVICES SHALL CONFORM AND BE PLACED IN ACCORDANCE WITH THE CURRENT "MINNESOTA MANUAL ON UNIFORM TRAFFIC CONTROL DEVICES" (MN MUTCD), INCLUDING PART VI, "FIELD MANUAL FOR TEMPORARY TRAFFIC CONTROL ZONE LAYOUTS".
2. UTILIZE FIELD MANUAL LAYOUT 16 DURING DAYTIME CONSTRUCTION OPERATIONS, AND RETURN TO NON-ACTIVE WORK ZONE TYPICAL AT CONCLUSION OF EACH WORK DAY (SEE SHEET 30).
3. CONTRACTOR SHALL SUPPLY AND INSTALL THE PORTABLE CHANGEABLE MESSAGE SIGN (CMS) A MINIMUM 10 DAYS PRIOR TO ACTUAL COMMENCEMENT OF ROAD WORK, TO A LOCATION AS SPECIFIED BY THE ENGINEER. SIGNS TO BE REMOVED WHEN ROAD WORK BEGINS. PAYMENT SHALL BE MADE AS PER ITEM 2563.613 PORTABLE CHANGEABLE MESSAGE SIGN BY THE UNIT/DAY.
4. CONTRACTOR SHALL COMPLY WITH THE LONGITUDINAL DROP-OFF GUIDELINES AS PER THE MN MUTCD.
5. CONTRACTOR SHALL SUPPLY, ERECT AND MAINTAIN THE TEMPORARY TRAFFIC CONTROL SIGNS AS SHOWN ON THIS DRAWING AND DETAILED IN THE SPECIAL PROVISIONS FROM THE TIME WORK COMMENCES ON THIS ROADWAY UNTIL THIS ROADWAY IS PERMANENTLY STRIPED. ALL NECESSARY TEMPORARY TRAFFIC CONTROL SIGNS SHALL BE PAID FOR AS PART OF TRAFFIC CONTROL LUMP SUM.
6. ALL INPLACE SIGNS THAT ARE TO BE TEMPED SHALL REMAIN IN PRISTINE CONDITION UNTIL REINSTALLED. SHALL BE PAID BY THE EACH ASSEMBLY WHEN REINSTALLATION IS REQUIRED.
7. ALL PERMANENT STRIPING AND PAVEMENT MESSAGES SHALL BE PLACED WITHIN 72 HOURS OF MAINLINE PAVING.

STATION 51+00

STATION 66+00

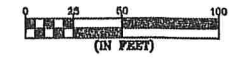
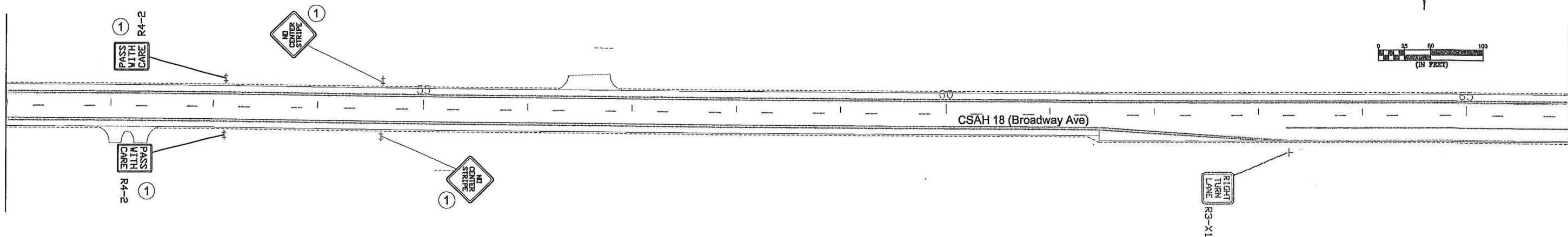

I HEREBY CERTIFY THAT THIS PLAN WAS PREPARED BY ME OR UNDER MY DIRECT SUPERVISION AND THAT I AM A DULY LICENSED PROFESSIONAL ENGINEER UNDER THE LAWS OF THE STATE OF MINNESOTA.
 PRINT NAME: DOUGLAS W. FISCHER
 SIGNATURE: *[Signature]*
 DATE: 2/25/19 LICENSE NO. 20235

DRAWN BY: TV DATE: 09/19/18
 DESIGN BY: DATE: _____
 CHECKED BY: DATE: _____



ANOKA COUNTY
 HIGHWAY DEPT.

STATE PROJECT NO. 002-618-032
 STATE AID PROJECT NO. _____
 CITY PROJECT NO. _____
 COUNTY PROJECT NO. _____

TRAFFIC CONTROL
 PLAN

Sheet 24 of 126 Sheets

NO	DATE	BY	CKD	APPR	REVISION

NAME: P/02-618-032/Base/Traffic/Existing S&S

NOTES:

1. ALL TRAFFIC CONTROL DEVICES SHALL CONFORM AND BE PLACED IN ACCORDANCE WITH THE CURRENT "MINNESOTA MANUAL ON UNIFORM TRAFFIC CONTROL DEVICES" (MN MUTCD), INCLUDING PART VI, "FIELD MANUAL FOR TEMPORARY TRAFFIC CONTROL ZONE LAYOUTS".
2. UTILIZE FIELD MANUAL LAYOUT 16 DURING DAYTIME CONSTRUCTION OPERATIONS, AND RETURN TO NON-ACTIVE WORK ZONE TYPICAL AT CONCLUSION OF EACH WORK DAY (SEE SHEET 30).
3. CONTRACTOR SHALL SUPPLY AND INSTALL THE PORTABLE CHANGEABLE MESSAGE SIGN (CMS) A MINIMUM 10 DAYS PRIOR TO ACTUAL COMMENCEMENT OF ROAD WORK, TO A LOCATION AS SPECIFIED BY THE ENGINEER. SIGNS TO BE REMOVED WHEN ROAD WORK BEGINS. PAYMENT SHALL BE MADE AS PER ITEM 2563.613 PORTABLE CHANGEABLE MESSAGE SIGN BY THE UNIT/DAY.
4. CONTRACTOR SHALL COMPLY WITH THE LONGITUDINAL DROP-OFF GUIDELINES AS PER THE MN MUTCD.
5. CONTRACTOR SHALL SUPPLY, ERECT AND MAINTAIN THE TEMPORARY TRAFFIC CONTROL SIGNS AS SHOWN ON THIS DRAWING AND DETAILED IN THE SPECIAL PROVISIONS FROM THE TIME WORK COMMENCES ON THIS ROADWAY UNTIL THIS ROADWAY IS PERMANENTLY STRIPED. ALL NECESSARY TEMPORARY TRAFFIC CONTROL SIGNS SHALL BE PAID FOR AS PART OF TRAFFIC CONTROL LUMP SUM.
6. ALL INPLACE SIGNS THAT ARE TO BE TEMPED SHALL REMAIN IN PRISTINE CONDITION UNTIL REINSTALLED. SHALL BE PAID BY THE EACH ASSEMBLY WHEN REINSTALLATION IS REQUIRED.
7. ALL PERMANENT STRIPING AND PAVEMENT MESSAGES SHALL BE PLACED WITHIN 72 HOURS OF MAINLINE PAVING.

STATION 66+00

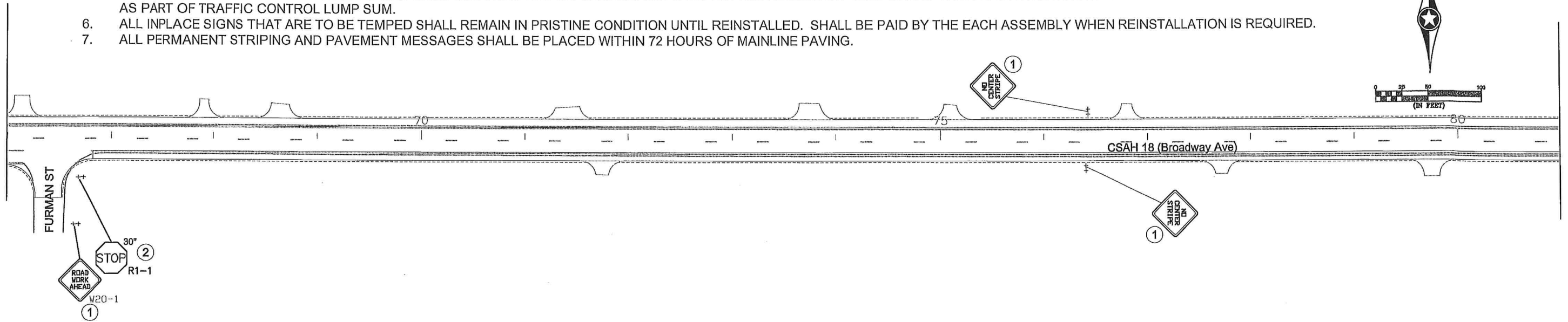

STATION 81+00

NOTES:

- 1 TEMPORARY TRAFFIC CONTROL DEVICE
- 2 INPLACE SIGN TO BE TEMPED DURING CONSTRUCTION ACTIVITES

STATION 81+00

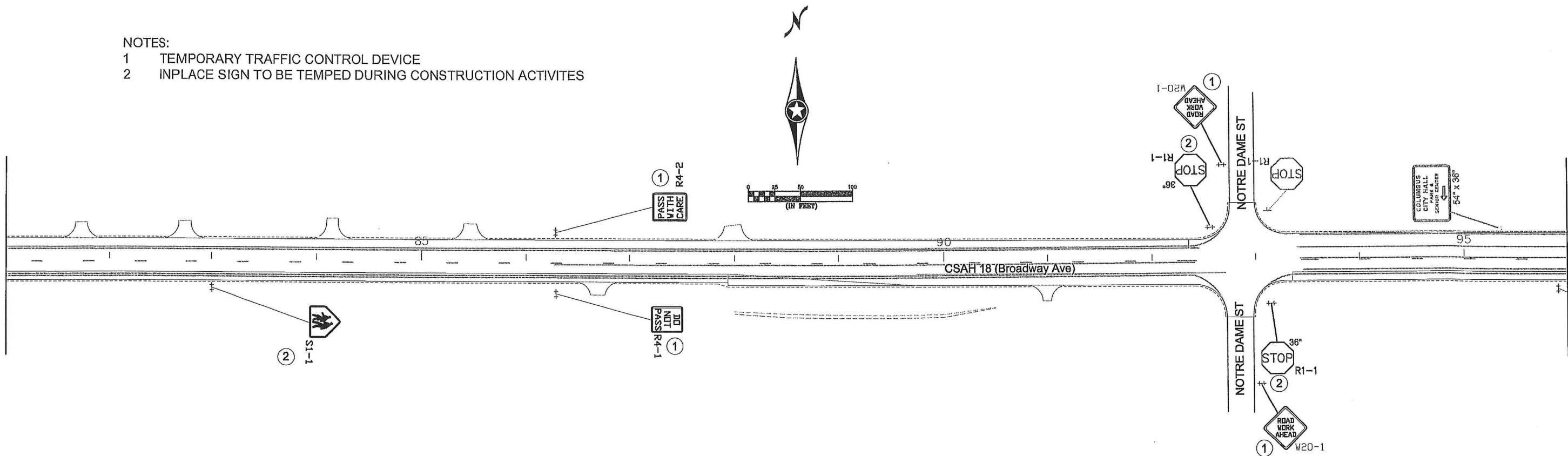

STATION 96+00

I HEREBY CERTIFY THAT THIS PLAN WAS PREPARED BY ME OR UNDER MY DIRECT SUPERVISION AND THAT I AM A DULY LICENSED PROFESSIONAL ENGINEER UNDER THE LAWS OF THE STATE OF MINNESOTA.
 PRINT NAME: DOUGLAS W. FISCHER
 SIGNATURE: *Douglas W. Fischer*
 DATE: 4/25/19 LICENSE NO. 20235

DRAWN BY: TV DATE: 09/19/18
 DESIGN BY: DATE:
 CHECKED BY: DATE:



ANOKA COUNTY
 HIGHWAY DEPT.

STATE PROJECT NO. 002-618-032
 STATE AID PROJECT NO.
 CITY PROJECT NO.
 COUNTY PROJECT NO.

TRAFFIC CONTROL
 PLAN

Sheet 25 of 126 Sheets

NO	DATE	BY	CKD	APPR	REVISION
NAME: P1/02-618-032/Base/Traffic/Existing S&S					

NOTES:

- 1 TEMPORARY TRAFFIC CONTROL DEVICE
- 2 INPLACE SIGN TO BE TEMPED DURING CONSTRUCTION ACTIVITES

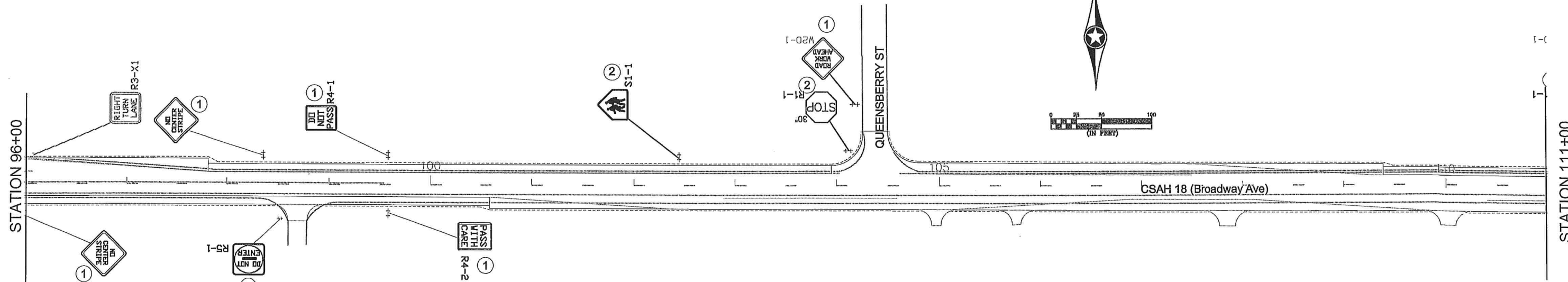

NOTES:

1. ALL TRAFFIC CONTROL DEVICES SHALL CONFORM AND BE PLACED IN ACCORDANCE WITH THE CURRENT "MINNESOTA MANUAL ON UNIFORM TRAFFIC CONTROL DEVICES" (MN MUTCD), INCLUDING PART VI, "FIELD MANUAL FOR TEMPORARY TRAFFIC CONTROL ZONE LAYOUTS".
2. UTILIZE FIELD MANUAL LAYOUT 16 DURING DAYTIME CONSTRUCTION OPERATIONS, AND RETURN TO NON-ACTIVE WORK ZONE TYPICAL AT CONCLUSION OF EACH WORK DAY (SEE SHEET 30).
3. CONTRACTOR SHALL SUPPLY AND INSTALL THE PORTABLE CHANGEABLE MESSAGE SIGN (CMS) A MINIMUM 10 DAYS PRIOR TO ACTUAL COMMENCEMENT OF ROAD WORK, TO A LOCATION AS SPECIFIED BY THE ENGINEER. SIGNS TO BE REMOVED WHEN ROAD WORK BEGINS. PAYMENT SHALL BE MADE AS PER ITEM 2563.613 PORTABLE CHANGEABLE MESSAGE SIGN BY THE UNIT/DAY.
4. CONTRACTOR SHALL COMPLY WITH THE LONGITUDINAL DROP-OFF GUIDELINES AS PER THE MN MUTCD.
5. CONTRACTOR SHALL SUPPLY, ERECT AND MAINTAIN THE TEMPORARY TRAFFIC CONTROL SIGNS AS SHOWN ON THIS DRAWING AND DETAILED IN THE SPECIAL PROVISIONS FROM THE TIME WORK COMMENCES ON THIS ROADWAY UNTIL THIS ROADWAY IS PERMANENTLY STRIPED. ALL NECESSARY TEMPORARY TRAFFIC CONTROL SIGNS SHALL BE PAID FOR AS PART OF TRAFFIC CONTROL LUMP SUM.
6. ALL INPLACE SIGNS THAT ARE TO BE TEMPED SHALL REMAIN IN PRISTINE CONDITION UNTIL REINSTALLED. SHALL BE PAID BY THE EACH ASSEMBLY WHEN REINSTALLATION IS REQUIRED.
7. ALL PERMANENT STRIPING AND PAVEMENT MESSAGES SHALL BE PLACED WITHIN 72 HOURS OF MAINLINE PAVING.

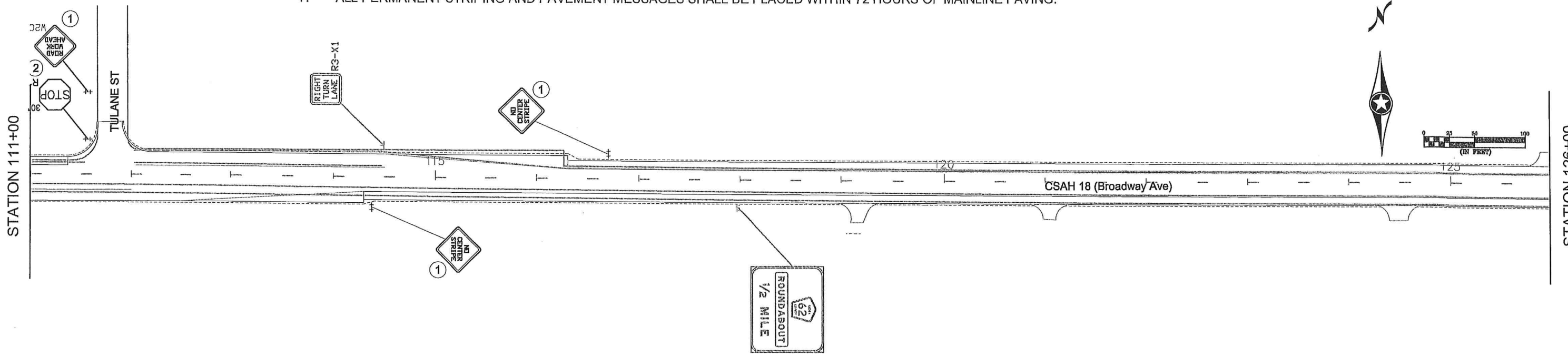

NO	DATE	BY	CKD	APPR	REVISION
NAME: P/02-618-032/Base/Traffic/Existing S&S					

I HEREBY CERTIFY THAT THIS PLAN WAS PREPARED BY ME OR UNDER MY DIRECT SUPERVISION AND THAT I AM A DULY LICENSED PROFESSIONAL ENGINEER UNDER THE LAWS OF THE STATE OF MINNESOTA.
 PRINT NAME: DOUGLAS W. FISCHER
 SIGNATURE: *[Signature]*
 DATE: 2/25/19 LICENSE NO. 20235

DRAWN BY: TV DATE: 09/19/18
 DESIGN BY: DATE:
 CHECKED BY: DATE:
 ANOKA COUNTY HIGHWAY DEPT.

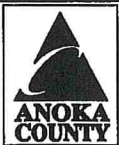

ANOKA COUNTY
 HIGHWAY DEPT.

STATE PROJECT NO. 002-618-032
 STATE AID PROJECT NO.
 CITY PROJECT NO.
 COUNTY PROJECT NO.
 TRAFFIC CONTROL PLAN

Sheet 26 of 126 Sheets

NOTES:

- 1 TEMPORARY TRAFFIC CONTROL DEVICE
- 2 INPLACE SIGN TO BE TEMPED DURING CONSTRUCTION ACTIVITES

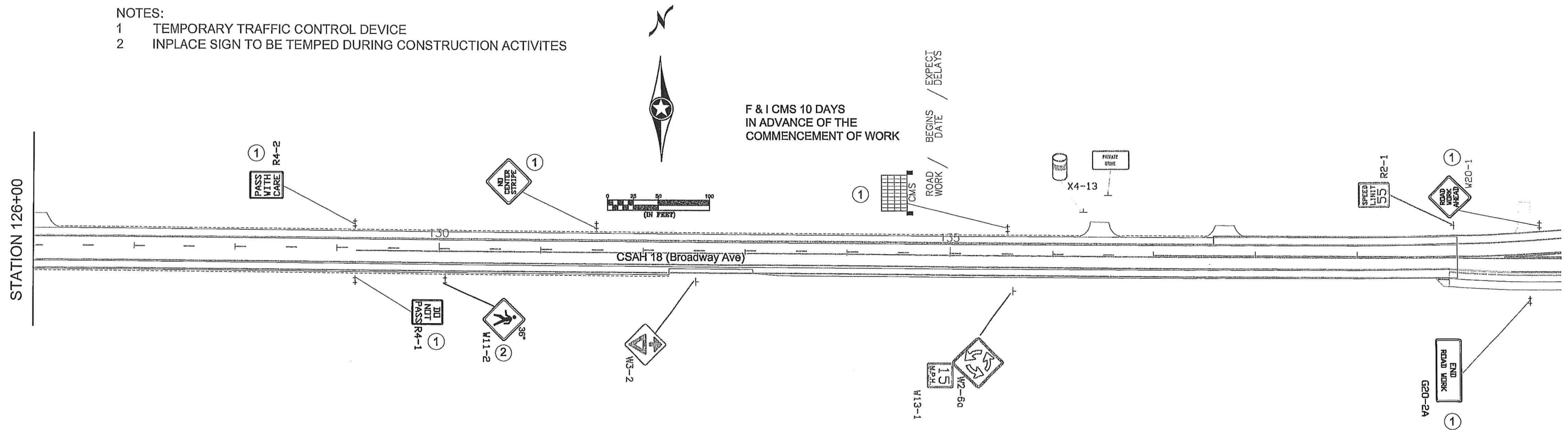

NOTES:

- 1. ALL TRAFFIC CONTROL DEVICES SHALL CONFORM AND BE PLACED IN ACCORDANCE WITH THE CURRENT "MINNESOTA MANUAL ON UNIFORM TRAFFIC CONTROL DEVICES" (MN MUTCD), INCLUDING PART VI, "FIELD MANUAL FOR TEMPORARY TRAFFIC CONTROL ZONE LAYOUTS".
- 2. UTILIZE FIELD MANUAL LAYOUT 16 DURING DAYTIME CONSTRUCTION OPERATIONS, AND RETURN TO NON-ACTIVE WORK ZONE TYPICAL AT CONCLUSION OF EACH WORK DAY (SEE SHEET 30).
- 3. CONTRACTOR SHALL SUPPLY AND INSTALL THE PORTABLE CHANGEABLE MESSAGE SIGN (CMS) A MINIMUM 10 DAYS PRIOR TO ACTUAL COMMENCEMENT OF ROAD WORK, TO A LOCATION AS SPECIFIED BY THE ENGINEER. SIGNS TO BE REMOVED WHEN ROAD WORK BEGINS. PAYMENT SHALL BE MADE AS PER ITEM 2563.613 PORTABLE CHANGEABLE MESSAGE SIGN BY THE UNIT/DAY.
- 4. CONTRACTOR SHALL COMPLY WITH THE LONGITUDINAL DROP-OFF GUIDELINES AS PER THE MN MUTCD.
- 5. CONTRACTOR SHALL SUPPLY, ERECT AND MAINTAIN THE TEMPORARY TRAFFIC CONTROL SIGNS AS SHOWN ON THIS DRAWING AND DETAILED IN THE SPECIAL PROVISIONS FROM THE TIME WORK COMMENCES ON THIS ROADWAY UNTIL THIS ROADWAY IS PERMANENTLY STRIPED. ALL NECESSARY TEMPORARY TRAFFIC CONTROL SIGNS SHALL BE PAID FOR AS PART OF TRAFFIC CONTROL LUMP SUM.
- 6. ALL INPLACE SIGNS THAT ARE TO BE TEMPED SHALL REMAIN IN PRISTINE CONDITION UNTIL REINSTALLED. SHALL BE PAID BY THE EACH ASSEMBLY WHEN REINSTALLATION IS REQUIRED.
- 7. ALL PERMANENT STRIPING AND PAVEMENT MESSAGES SHALL BE PLACED WITHIN 72 HOURS OF MAINLINE PAVING.

NO	DATE	BY	CKD	APPR	REVISION

I HEREBY CERTIFY THAT THIS PLAN WAS PREPARED BY ME OR UNDER MY DIRECT SUPERVISION AND THAT I AM A DULY LICENSED PROFESSIONAL ENGINEER UNDER THE LAWS OF THE STATE OF MINNESOTA.
 PRINT NAME: DOUGLAS W. FISCHER
 SIGNATURE: *[Signature]*
 DATE: 9/25/18 LICENSE NO. 20235

DRAWN BY: TV DATE 09/19/18
 DESIGN BY: DATE
 CHECKED BY: DATE



ANOKA COUNTY
 HIGHWAY DEPT.

STATE PROJECT NO. 002-618-032
 STATE AID PROJECT NO.
 CITY PROJECT NO.
 COUNTY PROJECT NO.

TRAFFIC CONTROL PLAN
 Sheet 27 of 126 Sheets

K TRAFFIC CONTROL SIGNS			
M.U.T.C.D. CODE	SIZE	INSERT	QUANTITY
R4-1	24" x 30"		4
R4-2	24" x 30"		6
G20-2A	48" x 24"		2
W8-12a	48" x 48"		12
W20-1	48" x 48"		10
W3-4	48" x 48"		AS NEEDED
W8-1A	48" x 48"		AS NEEDED
W8-1A	48" x 48"		AS NEEDED
W8-8	48" x 48"		AS NEEDED
W8-9	48" x 48"		AS NEEDED
W20-4	48" x 48"		AS NEEDED
W20-7	48" x 48"		AS NEEDED

K TRAFFIC CONTROL SIGNS			
M.U.T.C.D. CODE	SIZE	INSERT	QUANTITY
W21-X1	48" x 48"		AS NEEDED
TYPE A CHANNELIZER 42" WEIGHTED			AS NEEDED
TYPE B CHANNELIZER			AS NEEDED
CMS sign to be installed a minimum 10 days prior to actual commencement of road work. Signs to be removed when road work begins.			2 AT 10 DAYS EA

CHANGEABLE MESSAGE BOARD - MESSAGE SEQUENCE LAYOUT

		R	O	A	D		
		W	O	R	K		
		B	E	G	I	N	S

	<	D	A	T	E	>	
	E	X	P	E	C	T	
	D	E	L	A	Y	S	

CMS sign to be installed a minimum of ten days prior to actual commencement of road work. Signs to be removed when road work begins.

NOTES:

- ALL TRAFFIC CONTROL DEVICES SHALL CONFORM AND BE PLACED IN ACCORDANCE TO THE "MINNESOTA MANUAL ON UNIFORM TRAFFIC CONTROL DEVICES" (MN MUTCD), INCLUDING PART VI, "FIELD MANUAL" FOR TEMPORARY TRAFFIC CONTROL ZONE LAYOUTS".
- LOCATIONS OF ALL PERMANENT STRIPING AND PAVEMENT MARKINGS ARE APPROXIMATE. EXACT LOCATIONS WILL BE DETERMINED IN THE FIELD BY THE ENGINEER.
- ALL MAINLINE PERMANENT STRIPING AND PAVEMENT MESSAGES SHALL BE PLACED WITHIN 72 HOURS OF MAINLINE PAVING.
- SEE PERMANENT SIGN TABULATIONS FOR ADDITIONAL INFORMATION.
- ALL SEGMENT STRIPE LINES SHALL BE EPOXY. PERMANENT MESSAGES AND ARROWS SHALL BE PREFORMED THERMOPLASTIC.
- ALL SIGNS SHALL BE FURNISHED AND INSTALLED UNLESS OTHERWISE NOTED.

L TEMPORARY PAVEMENT MARKING TABULATION		
PAVEMENT MARKING REMOVAL PED CROSSING	SQ FT	108
PAVEMENT MARKING REMOVAL 24" STOP BARS	LIN FT	38

NO	DATE	BY	CKD	APPR	REVISION

NAME: P/02-618-032/Base/Traffic/Existing S&S

I HEREBY CERTIFY THAT THIS PLAN WAS PREPARED BY ME OR UNDER MY DIRECT SUPERVISION AND THAT I AM A DULY LICENSED PROFESSIONAL ENGINEER UNDER THE LAWS OF THE STATE OF MINNESOTA.
 PRINT NAME: DOUGLAS W. FISCHER
 SIGNATURE:
 DATE: 7/25/19 LICENSE NO. 20235

DRAWN BY: TV DATE: 09/19/18
 DESIGN BY: DATE: _____
 CHECKED BY: DATE: _____



ANOKA COUNTY
 HIGHWAY DEPT.

STATE PROJECT NO. 002-618-032
 STATE AID PROJECT NO. _____
 CITY PROJECT NO. _____
 COUNTY PROJECT NO. _____

TRAFFIC CONTROL
 PLAN

C.S.A.H. 18 (BROADWAY AVE.) ROLLING SHOULDER STAGING

STAGING NOTES

ALL LAYOUTS MUST ABIDE BY LATEST VERSION OF MN MUTCD AND MNDOT TEMP TRAFFIC CONTROL ZONE LAYOUTS FIELD MANUAL

- ① AT THE CONCLUSION OF EACH WORKDAY, THE SHOULDER / AUX. LANE GRADE MUST BE BROUGHT UP TO NO MORE THAN TWO INCHES BELOW THE EXISTING PAVEMENT SURFACE SEE DETAIL "A" BELOW
- ② CONTRACTORS DISCRETION AS TO WHICH SHOULDER DIRECTION WORK TO BEGIN. AT NO TIME DURING THE PROJECT WILL CONSTRUCTION BE ALLOWED ON BOTH SIDES OF THE ROADWAY.
- ③ BITUMINOUS LIFTS TO MATCH EXISTING PRIOR TO ALTERNATING SIDES.
- ④ THROUGH LANES MUST BE SWEEP CLEAN PRIOR TO REVERTING TO THE NON-WORK ZONE CONFIGURATION
- ⑤ ONE WAY FLAGGING OPERATIONS SHALL NOT EXCEED 1500' IN LENGTH NOR EXCEED 5 MINUTES DELAY IN EITHER DIRECTION. TWO FLAGMEN MINIMUM REQUIRED

WORKING OPERATIONS

FLAGGING TRAFFIC CONTROL

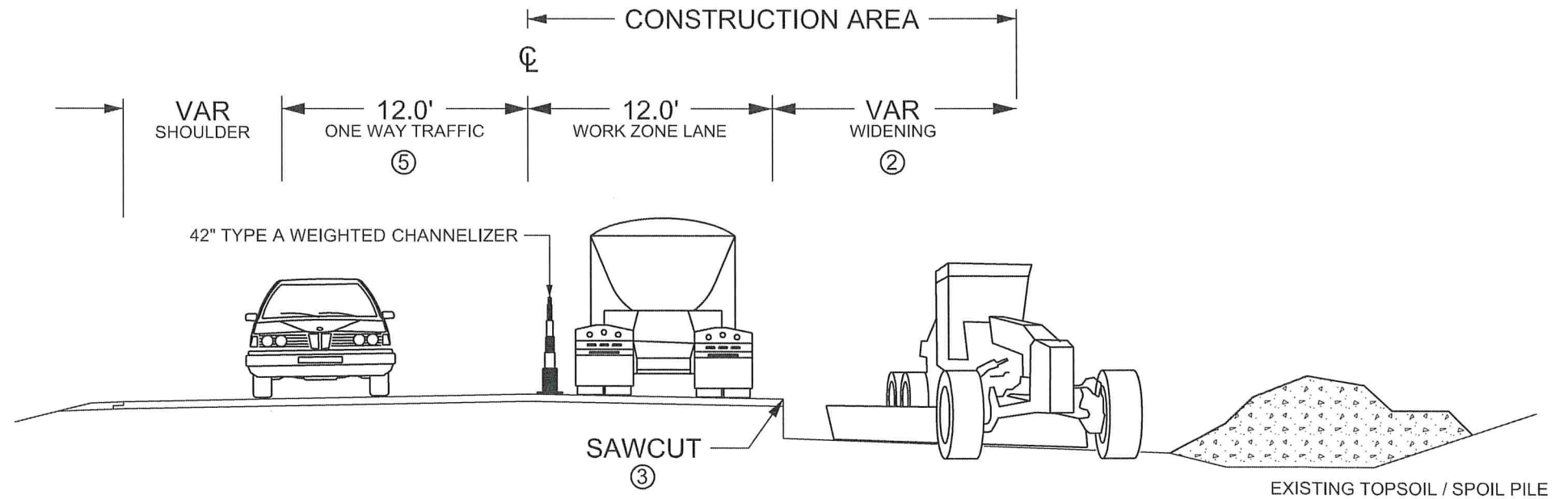

NON-ACTIVE WORK ZONE

OPEN TO TWO WAY TRAFFIC

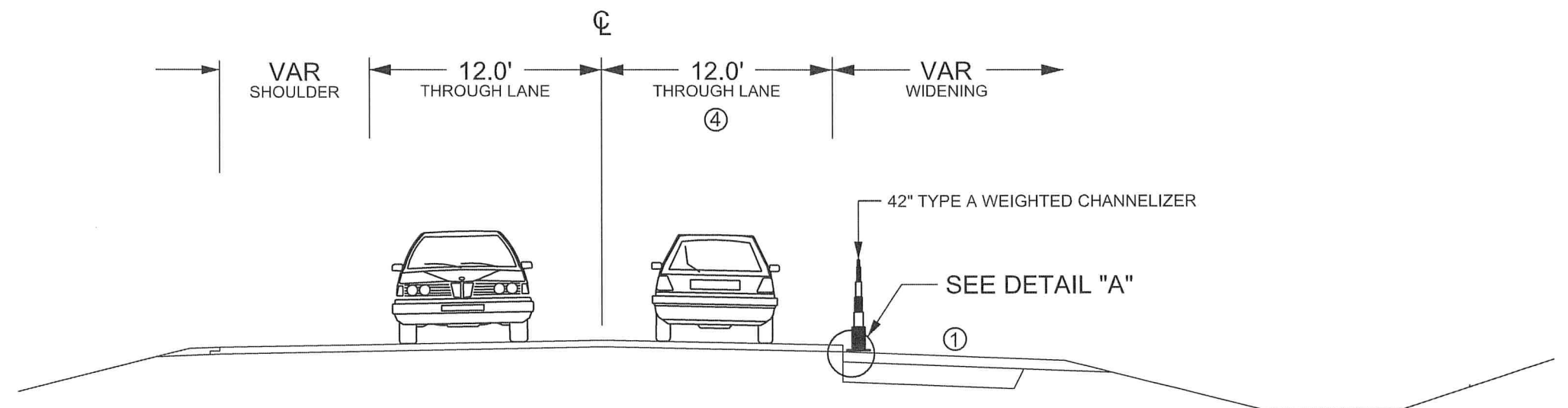

DETAIL "A"

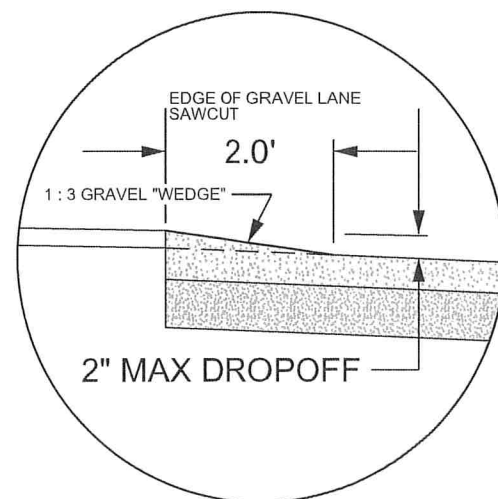

NO	DATE	BY	CKD	APPR	REVISION

NAME: P:\002-618-032\Plan\0261832_SHLD_TYP.dgn 01/28/2019 6:51:45 AM

I HEREBY CERTIFY THAT THIS PLAN WAS PREPARED BY ME OR UNDER MY DIRECT SUPERVISION AND THAT I AM A DULY LICENSED PROFESSIONAL ENGINEER UNDER THE LAWS OF THE STATE OF MINNESOTA.
 PRINT NAME: NICHOLAS DOBDA
 SIGNATURE: *Nicholas Dobda*
 DATE: 2-21-19 LICENSE NO. 49046

DRAWN BY: NJD DATE: 11-20-18
 DESIGN BY: NJD DATE: 11-20-18
 CHECKED BY: HGRAMS DATE: 11-20-18

ANOKA COUNTY
HIGHWAY DEPT.

SP 002-618-032

SHOULDER CONSTRUCTION STAGING CONCEPT
 Sheet 29 of 126 Sheets

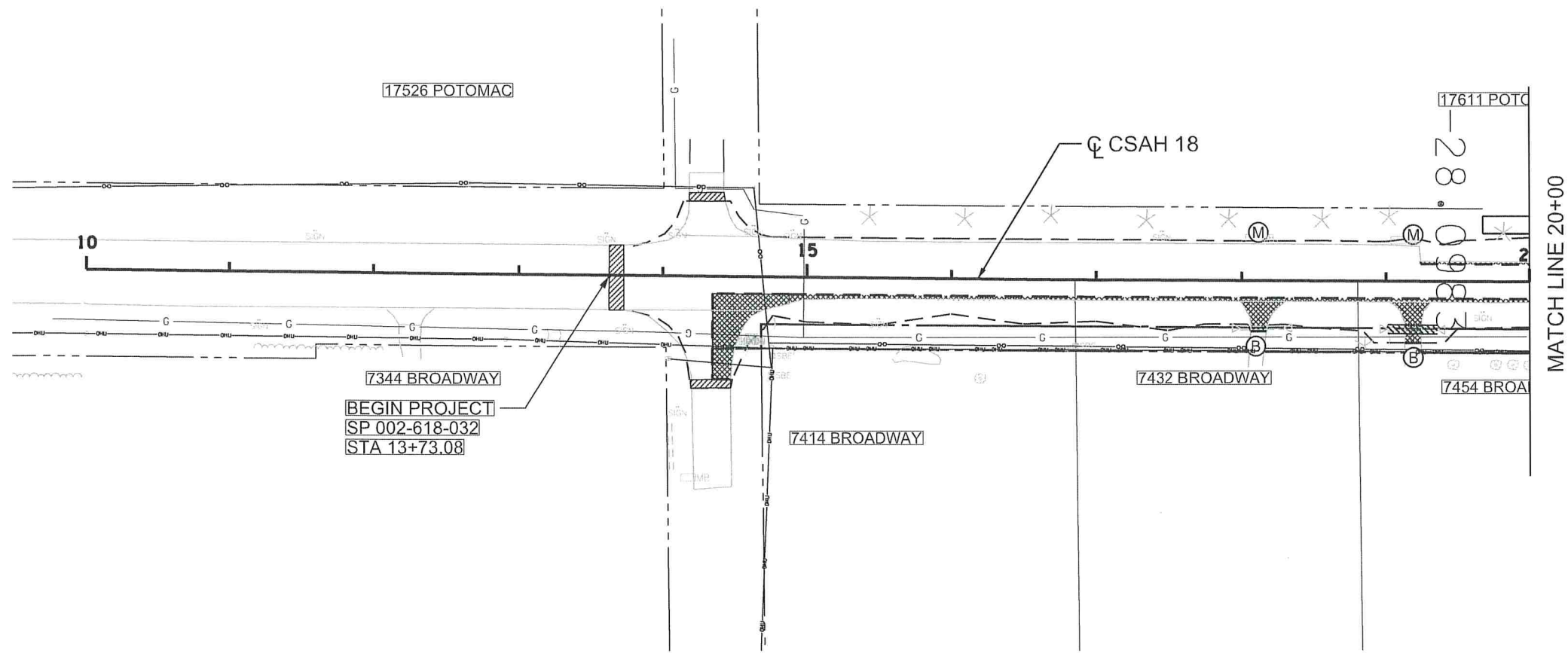

LEGEND	
	REMOVE BITUMINOUS PAVEMENT
	REMOVE CONCRETE DRIVEWAY PAVEMENT
	MILL BITUMINOUS PAVEMENT (JOINTS)
	SAWING BIT. PAVEMENT FULL DEPTH STREETS & BIT. DR WAYS, 12' LT & 12' RT OF CENTER LINE, LENGTH OF PROJECT- EXCEPTION IN EXISTING RTL OR BYPASS.
	CLEAR AND GRUB TREE BY THE EACH
	GRUB TREE BY THE EACH
	CLEAR & GRUB (ACRE)
	REMOVE PIPE CULVERTS
	REMOVE PIPE APRON
	SAWCUT BITUMINOUS PAVEMENT FULL DEPTH REMOVE PAVEMENT
	SAWCUT CONCRETE DRIVEWAY FULL DEPTH/REMOVE
	RELOCATE MAILBOX
	CONSTRUCTION LIMIT
	EXISTING R/W
	NEW R/W
	PERMANENT EASEMENT
	CENTERPOINT GAS
	CONNEXUS MIDco_INTERNET
	CENTURYLINK_UG

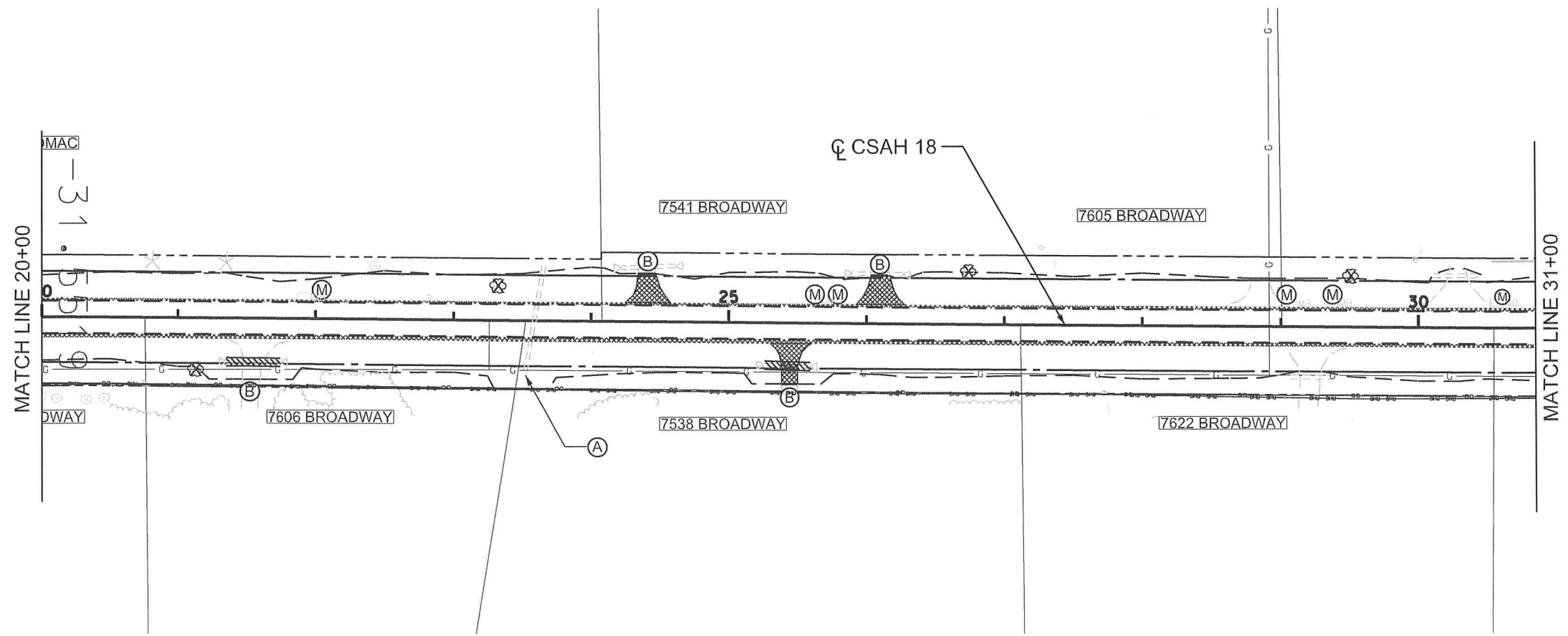
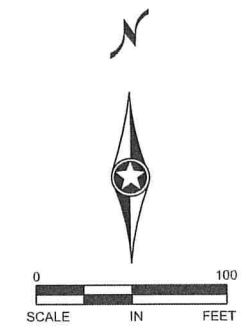

REMOVAL NOTES

THE CONTRACTOR SHALL PERFORM ALL CLEARING AND GRUBBING AS DIRECTED AND MARKED IN THE FIELD BY THE ENGINEER. THE CONTRACTOR SHALL OTHERWISE PROTECT ALL EXISTING TREES NOT SPECIFICALLY MARKED FOR REMOVAL.

ALL PRIVATE UTILITIES TO BE RELOCATED BY OTHERS AS REQUIRED. SEE IN PLACE UTILITY TABULATION FOR MORE INFORMATION.

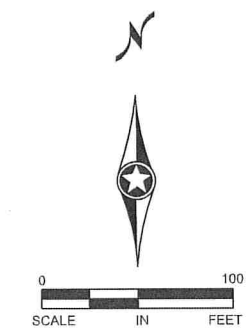

NO	DATE	BY	CKD	APPR	REVISION

NAME: P:\002-618-032\Plan\0261832_REM_P1.dgn 01/28/2019 6:51:50 AM

I HEREBY CERTIFY THAT THIS PLAN WAS PREPARED BY ME OR UNDER MY DIRECT SUPERVISION AND THAT I AM A DULY LICENSED PROFESSIONAL ENGINEER UNDER THE LAWS OF THE STATE OF MINNESOTA.

PRINT NAME: NICHOLAS DOBDA

SIGNATURE: *Nicholas Dobda*

DATE: 2-21-19 LICENSE NO. 49046

DRAWN BY: KT DATE: 10/24/18

DESIGN BY: JCF DATE: 10/24/18

CHECKED BY: NJD DATE: 10/24/18

**ANOKA COUNTY
HIGHWAY DEPT.**

SP 002-618-032

REMOVAL PLAN

STA 10+00.00 TO 31+00.00

Sheet 30 of 126 Sheets

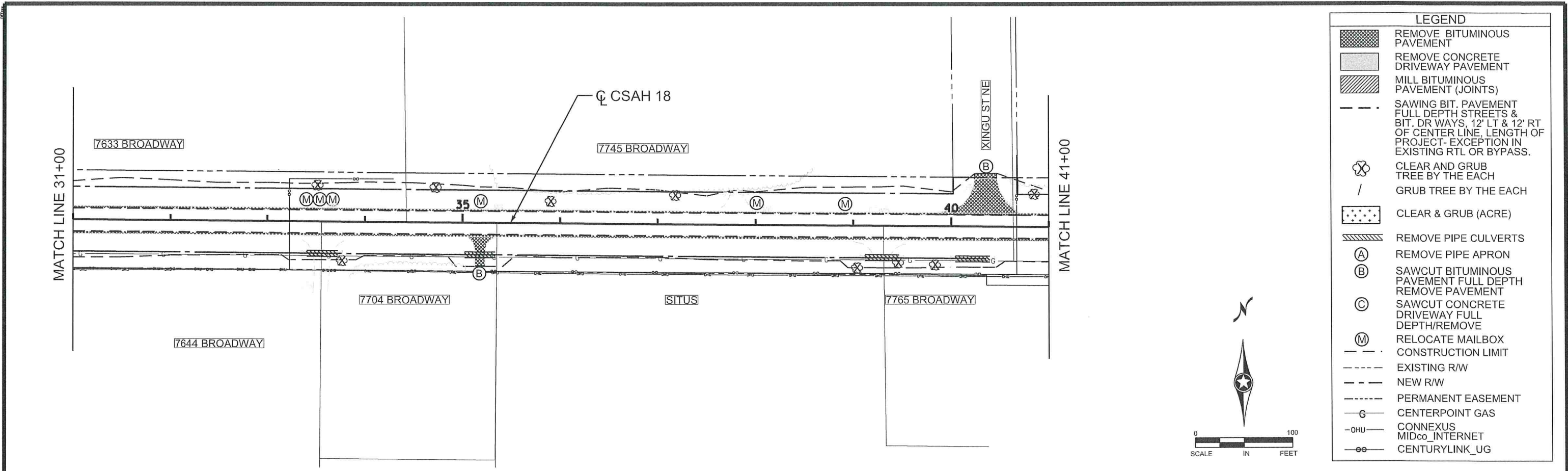

- LEGEND**
- REMOVE BITUMINOUS PAVEMENT
 - REMOVE CONCRETE DRIVEWAY PAVEMENT
 - MILL BITUMINOUS PAVEMENT (JOINTS)
 - SAWING BIT. PAVEMENT FULL DEPTH STREETS & BIT. DR WAYS, 12' LT & 12' RT OF CENTER LINE, LENGTH OF PROJECT- EXCEPTION IN EXISTING RTL OR BYPASS.
 - CLEAR AND GRUB TREE BY THE EACH
 - GRUB TREE BY THE EACH
 - CLEAR & GRUB (ACRE)
 - REMOVE PIPE CULVERTS
 - REMOVE PIPE APRON
 - SAWCUT BITUMINOUS PAVEMENT FULL DEPTH REMOVE PAVEMENT
 - SAWCUT CONCRETE DRIVEWAY FULL DEPTH/REMOVE
 - RELOCATE MAILBOX CONSTRUCTION LIMIT
 - EXISTING R/W
 - NEW R/W
 - PERMANENT EASEMENT
 - CENTERPOINT GAS
 - CONNEXUS MIDco_INTERNET
 - CENTURYLINK_UG

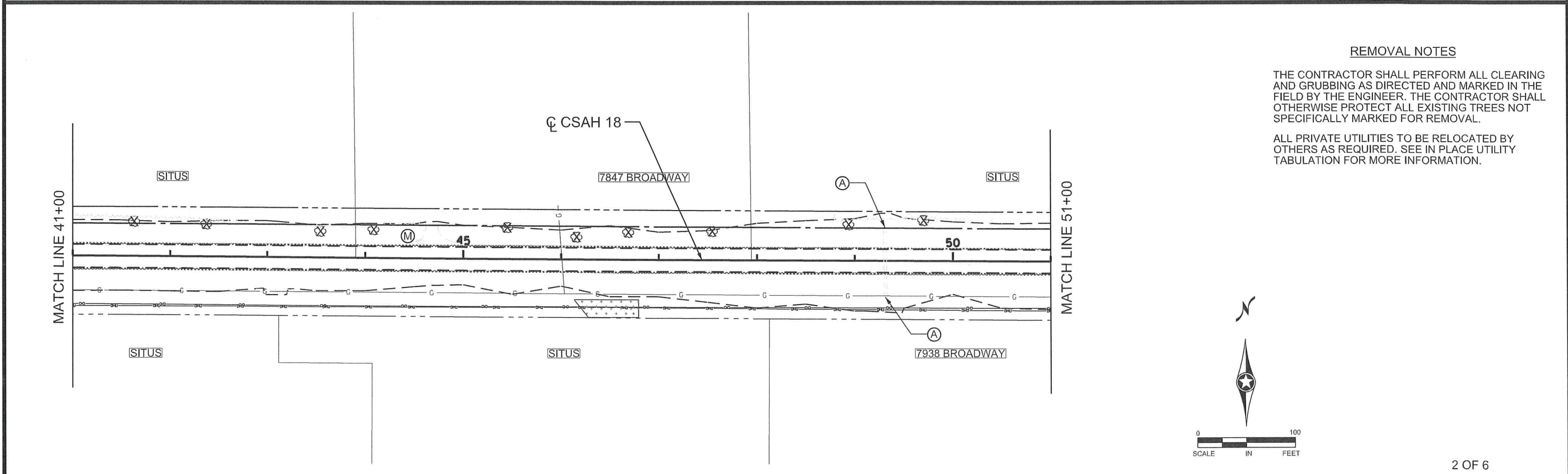
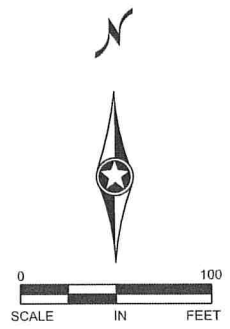

REMOVAL NOTES

THE CONTRACTOR SHALL PERFORM ALL CLEARING AND GRUBBING AS DIRECTED AND MARKED IN THE FIELD BY THE ENGINEER. THE CONTRACTOR SHALL OTHERWISE PROTECT ALL EXISTING TREES NOT SPECIFICALLY MARKED FOR REMOVAL.

ALL PRIVATE UTILITIES TO BE RELOCATED BY OTHERS AS REQUIRED. SEE IN PLACE UTILITY TABULATION FOR MORE INFORMATION.

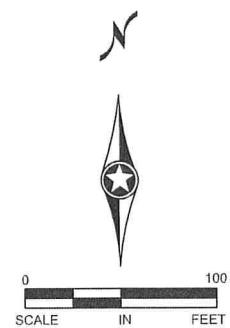

NO	DATE	BY	CHKD	APPR	REVISION
NAME: P:\002-618-032\Plan\0261832_REM_P2.dgn 01/29/2019 6:51:52 AM					

I HEREBY CERTIFY THAT THIS PLAN WAS PREPARED BY ME OR UNDER MY DIRECT SUPERVISION AND THAT I AM A DULY LICENSED PROFESSIONAL ENGINEER UNDER THE LAWS OF THE STATE OF MINNESOTA.

PRINT NAME: NICHOLAS DOBDA
 SIGNATURE: *[Signature]*
 DATE: 2-21-19 LICENSE NO. 49046

DRAWN BY: KT DATE: 10/24/18
 DESIGN BY: JCF DATE: 10/24/18
 CHECKED BY: NJD DATE: 10/24/18

ANOKA COUNTY
HIGHWAY DEPT.

SP 002-618-032

REMOVAL PLAN
 STA 31+00.00 TO 51+00.00
 Sheet 31 of 126 Sheets

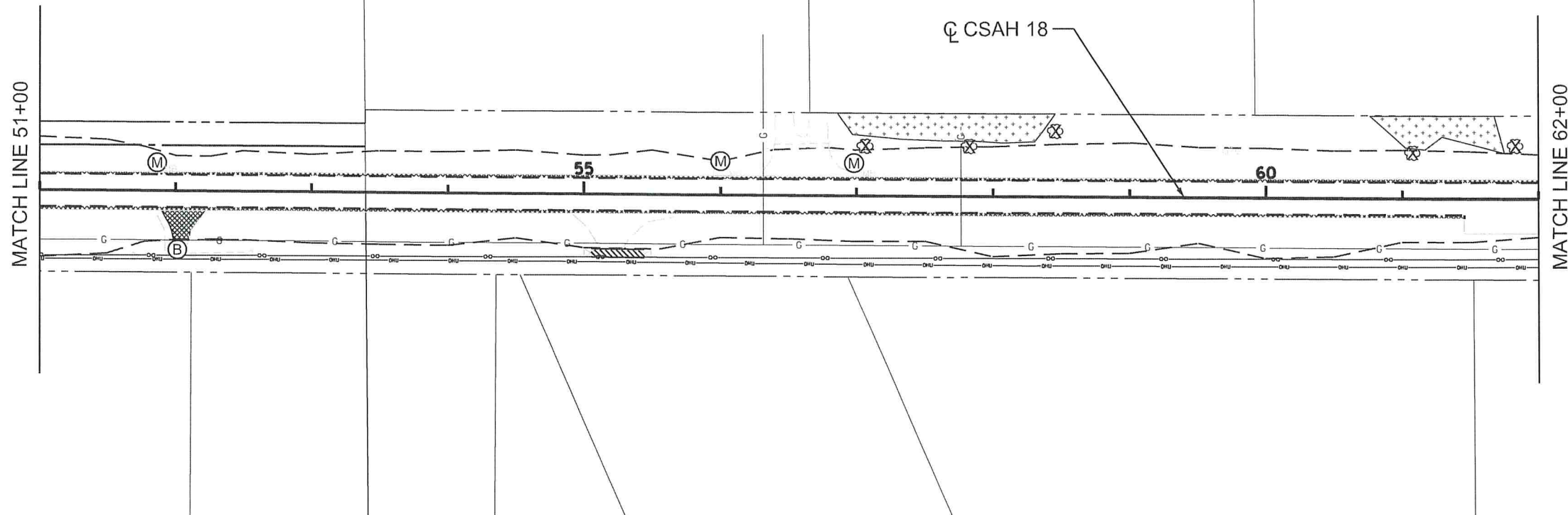

LEGEND	
	REMOVE BITUMINOUS PAVEMENT
	REMOVE CONCRETE DRIVEWAY PAVEMENT
	MILL BITUMINOUS PAVEMENT (JOINTS)
	SAWING BIT. PAVEMENT FULL DEPTH STREETS & BIT. DR WAYS, 12' LT & 12' RT OF CENTER LINE, LENGTH OF PROJECT- EXCEPTION IN EXISTING RTL OR BYPASS.
	CLEAR AND GRUB TREE BY THE EACH
	GRUB TREE BY THE EACH
	CLEAR & GRUB (ACRE)
	REMOVE PIPE CULVERTS
	REMOVE PIPE APRON
	SAWCUT BITUMINOUS PAVEMENT FULL DEPTH REMOVE PAVEMENT
	SAWCUT CONCRETE DRIVEWAY FULL DEPTH/REMOVE
	RELOCATE MAILBOX CONSTRUCTION LIMIT
	EXISTING R/W
	NEW R/W
	PERMANENT EASEMENT
	CENTERPOINT GAS
	CONNEXUS MIDco INTERNET
	CENTURYLINK_UG

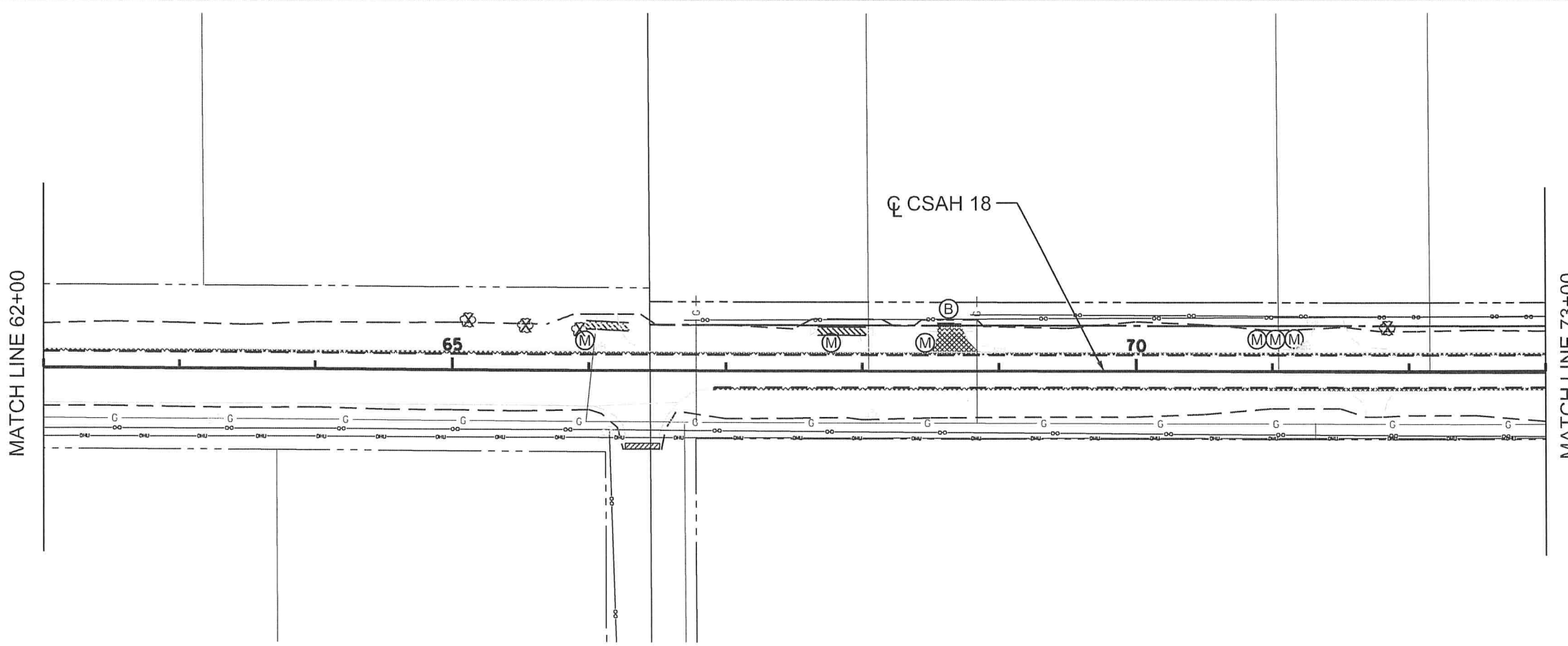
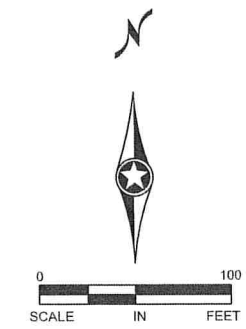

REMOVAL NOTES

THE CONTRACTOR SHALL PERFORM ALL CLEARING AND GRUBBING AS DIRECTED AND MARKED IN THE FIELD BY THE ENGINEER. THE CONTRACTOR SHALL OTHERWISE PROTECT ALL EXISTING TREES NOT SPECIFICALLY MARKED FOR REMOVAL.

ALL PRIVATE UTILITIES TO BE RELOCATED BY OTHERS AS REQUIRED. SEE IN PLACE UTILITY TABULATION FOR MORE INFORMATION.

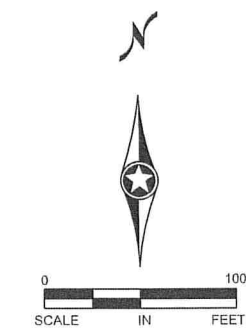

NO	DATE	BY	CKD	APPR	REVISION
NAME: P:\002-618-032\Plan\0261832_REM_P3.dgn 01/28/2019 6:51:54 AM					

I HEREBY CERTIFY THAT THIS PLAN WAS PREPARED BY ME OR UNDER MY DIRECT SUPERVISION AND THAT I AM A DULY LICENSED PROFESSIONAL ENGINEER UNDER THE LAWS OF THE STATE OF MINNESOTA.

PRINT NAME: NICHOLAS DOBDA

SIGNATURE: *Nicholas Dobda*

DATE: 2-21-19 LICENSE NO. 49046

DRAWN BY: KT DATE: 10/24/18

DESIGN BY: JCF DATE: 10/24/18

CHECKED BY: NJD DATE: 10/24/18

ANOKA COUNTY
HIGHWAY DEPT.

SP 002-618-032

REMOVAL PLAN

STA 51+00.00 TO 73+00.00

Sheet 32 of 126 Sheets

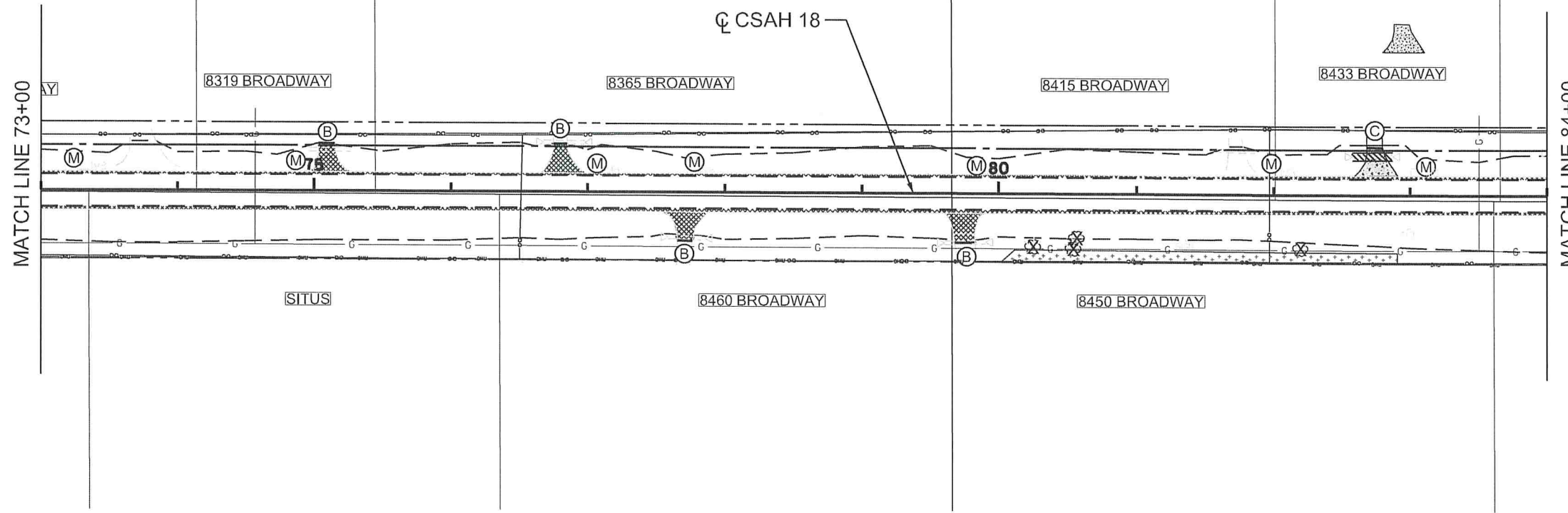

LEGEND	
	REMOVE BITUMINOUS PAVEMENT
	REMOVE CONCRETE DRIVEWAY PAVEMENT
	MILL BITUMINOUS PAVEMENT (JOINTS)
	SAWING BIT. PAVEMENT FULL DEPTH STREETS & BIT. DR WAYS, 12' LT & 12' RT OF CENTER LINE, LENGTH OF PROJECT- EXCEPTION IN EXISTING RTL OR BYPASS.
	CLEAR AND GRUB TREE BY THE EACH
/	GRUB TREE BY THE EACH
	CLEAR & GRUB (ACRE)
	REMOVE PIPE CULVERTS
(A)	REMOVE PIPE APRON
(B)	SAWCUT BITUMINOUS PAVEMENT FULL DEPTH REMOVE PAVEMENT
(C)	SAWCUT CONCRETE DRIVEWAY FULL DEPTH/REMOVE
(M)	RELOCATE MAILBOX CONSTRUCTION LIMIT
- - -	EXISTING R/W
- - - -	NEW R/W
- - - - -	PERMANENT EASEMENT
G	CENTERPOINT GAS
-OHU-	CONNEXUS
-OO-	MIDco_INTERNET
-OO-	CENTURYLINK_UG

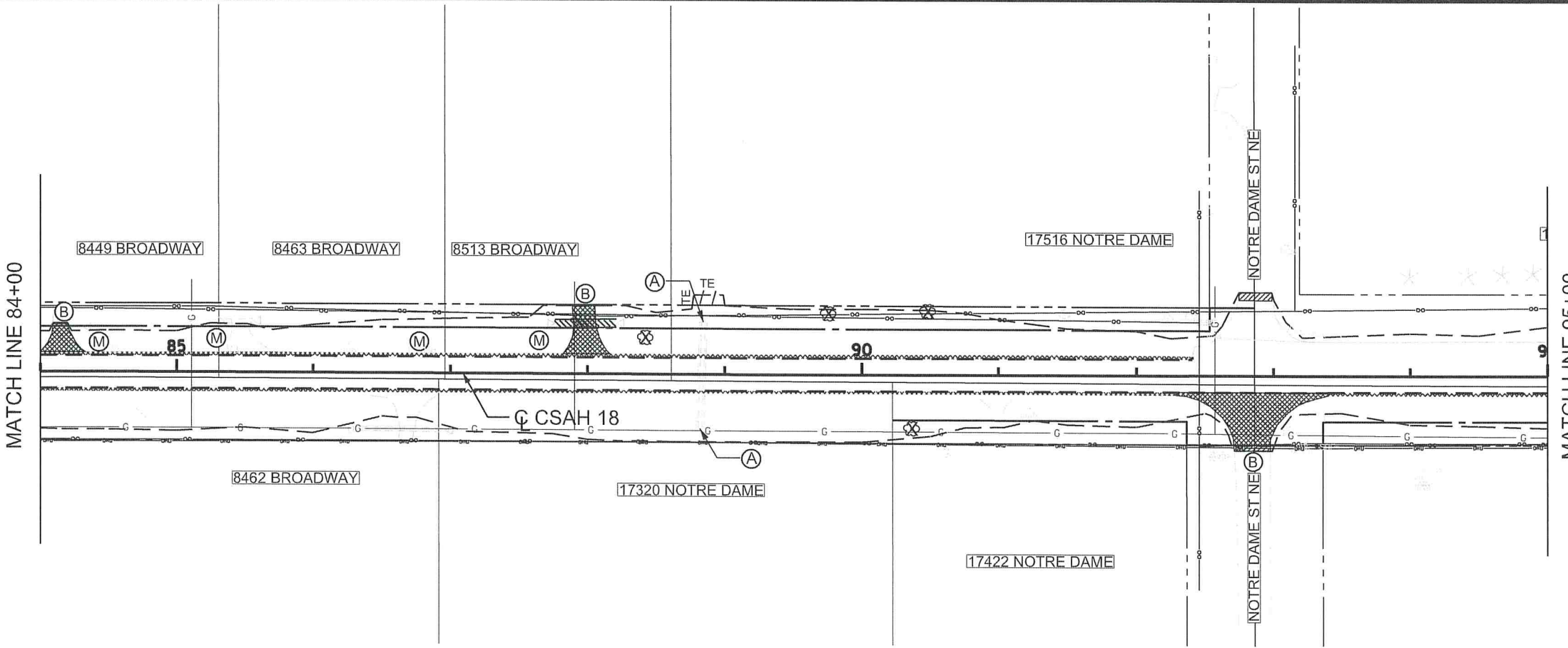
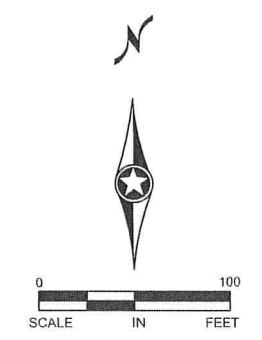

REMOVAL NOTES

THE CONTRACTOR SHALL PERFORM ALL CLEARING AND GRUBBING AS DIRECTED AND MARKED IN THE FIELD BY THE ENGINEER. THE CONTRACTOR SHALL OTHERWISE PROTECT ALL EXISTING TREES NOT SPECIFICALLY MARKED FOR REMOVAL.

ALL PRIVATE UTILITIES TO BE RELOCATED BY OTHERS AS REQUIRED. SEE IN PLACE UTILITY TABULATION FOR MORE INFORMATION.

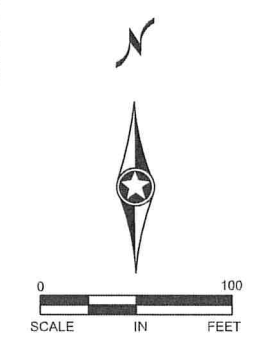

NO	DATE	BY	CKD	APPR	REVISION

NAME: P:\002-618-032\Plan\0261832_REM_P4.dgn 01/29/2019 6:51:56 AM

I HEREBY CERTIFY THAT THIS PLAN WAS PREPARED BY ME OR UNDER MY DIRECT SUPERVISION AND THAT I AM A DULY LICENSED PROFESSIONAL ENGINEER UNDER THE LAWS OF THE STATE OF MINNESOTA.

PRINT NAME: NICHOLAS DOBDA

SIGNATURE: *Nicholas Dobda*

DATE: 2-21-19 LICENSE NO. 49046

DRAWN BY: KT DATE: 10/24/18

DESIGN BY: JCF DATE: 10/24/18

CHECKED BY: NJD DATE: 10/24/18

ANOKA COUNTY
HIGHWAY DEPT.

SP 002-618-032

REMOVAL PLAN

STA 73+00.00 TO 95+00.00

Sheet 33 of 126 Sheets

MATCH LINE 95+00

7537 NOTRE DAME

CL CSAH 18

17520 QUEENSBERRY

QUEENSBERRY ST NE

175

MATCH LINE 106+00

100



















105

CROSSROADS
EVANGELICAL

CROSSROADS
EVANGELICAL

8760 BROADWAY

LEGEND

-  REMOVE BITUMINOUS PAVEMENT
-  REMOVE CONCRETE DRIVEWAY PAVEMENT
-  MILL BITUMINOUS PAVEMENT (JOINTS)
-  SAWING BIT. PAVEMENT FULL DEPTH STREETS & BIT. DR WAYS, 12' LT & 12' RT OF CENTER LINE, LENGTH OF PROJECT- EXCEPTION IN EXISTING RTL OR BYPASS.
-  CLEAR AND GRUB TREE BY THE EACH
-  GRUB TREE BY THE EACH
-  CLEAR & GRUB (ACRE)
-  REMOVE PIPE CULVERTS
-  REMOVE PIPE APRON
-  SAWCUT BITUMINOUS PAVEMENT FULL DEPTH REMOVE PAVEMENT
-  SAWCUT CONCRETE DRIVEWAY FULL DEPTH/REMOVE
-  RELOCATE MAILBOX
-  CONSTRUCTION LIMIT
-  EXISTING R/W
-  NEW R/W
-  PERMANENT EASEMENT
-  CENTERPOINT GAS
-  CONNEXUS MIDco_INTERNET
-  CENTURYLINK_UG

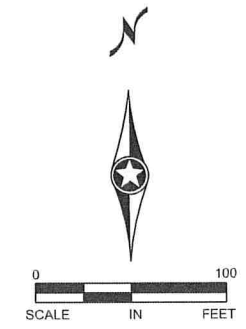

MATCH LINE 106+00

29 QUEENSBERRY

17527 TULANE

TULANE ST NE

WARNING
 HIGH-PRESSURE PIPELINE(S)
 Excavation and/or Construction Prohibited
 Without compliance with State One-Call,
 AND
 Without Written Permission From
 Magellan Pipeline Company.

8922 176TH

CL CSAH 18

MAGELLAN
PIPELINE

MATCH LINE 117+00

110

115

8816 BROADWAY

8842 BROADWAY

MAGELLAN
PIPELINE

SITUS

REMOVAL NOTES

THE CONTRACTOR SHALL PERFORM ALL CLEARING AND GRUBBING AS DIRECTED AND MARKED IN THE FIELD BY THE ENGINEER. THE CONTRACTOR SHALL OTHERWISE PROTECT ALL EXISTING TREES NOT SPECIFICALLY MARKED FOR REMOVAL.

ALL PRIVATE UTILITIES TO BE RELOCATED BY OTHERS AS REQUIRED. SEE IN PLACE UTILITY TABULATION FOR MORE INFORMATION.

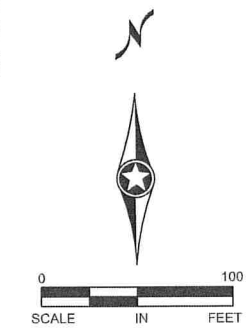

NO	DATE	BY	CKD	APPR	REVISION

NAME: P:\002-618-032\Plan\0261832_REM_P5.dgn 01/28/2019 6:51:58 AM

I HEREBY CERTIFY THAT THIS PLAN WAS PREPARED BY ME OR UNDER MY DIRECT SUPERVISION AND THAT I AM A DULY LICENSED PROFESSIONAL ENGINEER UNDER THE LAWS OF THE STATE OF MINNESOTA.

PRINT NAME: NICHOLAS DOBDA

SIGNATURE: 

DATE: 2-21-19 LICENSE NO. 49046

DRAWN BY: KT DATE: 10/24/18

DESIGN BY: JCF DATE: 10/24/18

CHECKED BY: NJD DATE: 10/24/18

 ANOKA COUNTY
HIGHWAY DEPT.

SP 002-618-032

REMOVAL PLAN

STA 95+00.00 TO 117+00.00

Sheet 34 of 126 Sheets

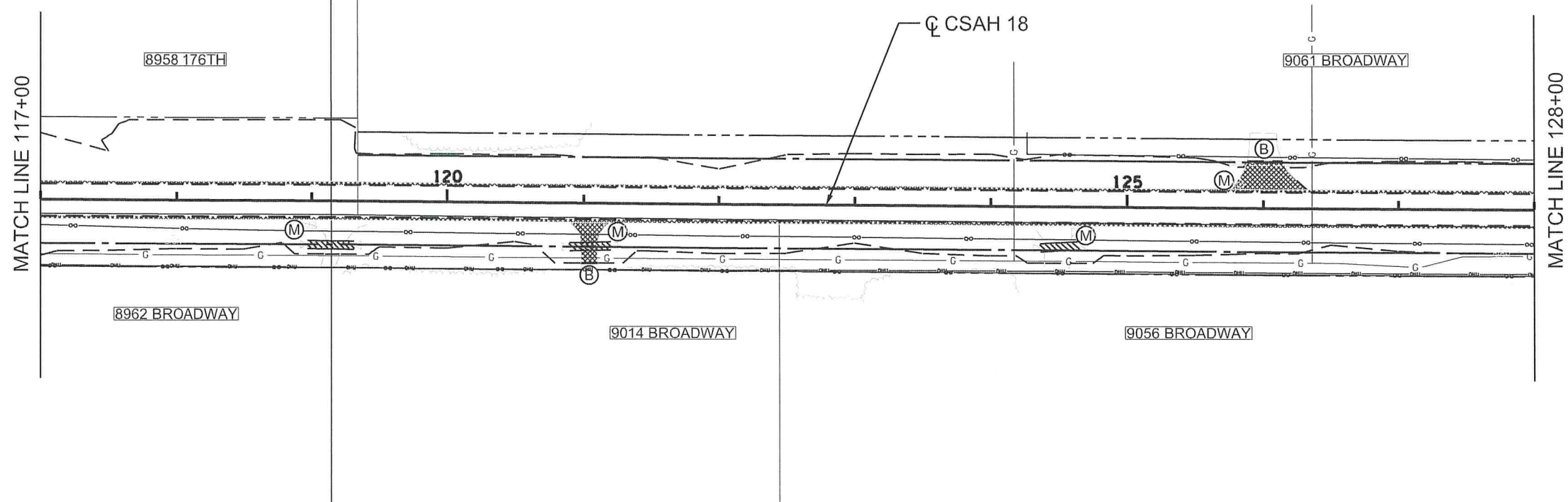

LEGEND

- REMOVE BITUMINOUS PAVEMENT
- REMOVE CONCRETE DRIVEWAY PAVEMENT
- MILL BITUMINOUS PAVEMENT (JOINTS)
- SAWING BIT. PAVEMENT FULL DEPTH STREETS & BIT. DR WAYS, 12' LT & 12' RT OF CENTER LINE, LENGTH OF PROJECT- EXCEPTION IN EXISTING RTL OR BYPASS.
- CLEAR AND GRUB TREE BY THE EACH
- CLEAR & GRUB (ACRE)
- REMOVE PIPE CULVERTS
- REMOVE PIPE APRON
- SAWCUT BITUMINOUS DRIVEWAY / STREET PAVEMENT FULL DEPTH REMOVE PAVEMENT
- SAWCUT CONCRETE DRIVEWAY PAVEMENT FULL DEPTH REMOVE PAVEMENT
- RELOCATE MAILBOX CONSTRUCTION LIMIT
- EXISTING R/W
- NEW R/W
- PERMANENT EASEMENT
- CENTERPOINT GAS
- CONNEXUS
- MIDco INTERNET
- CENTURYLINK_UG

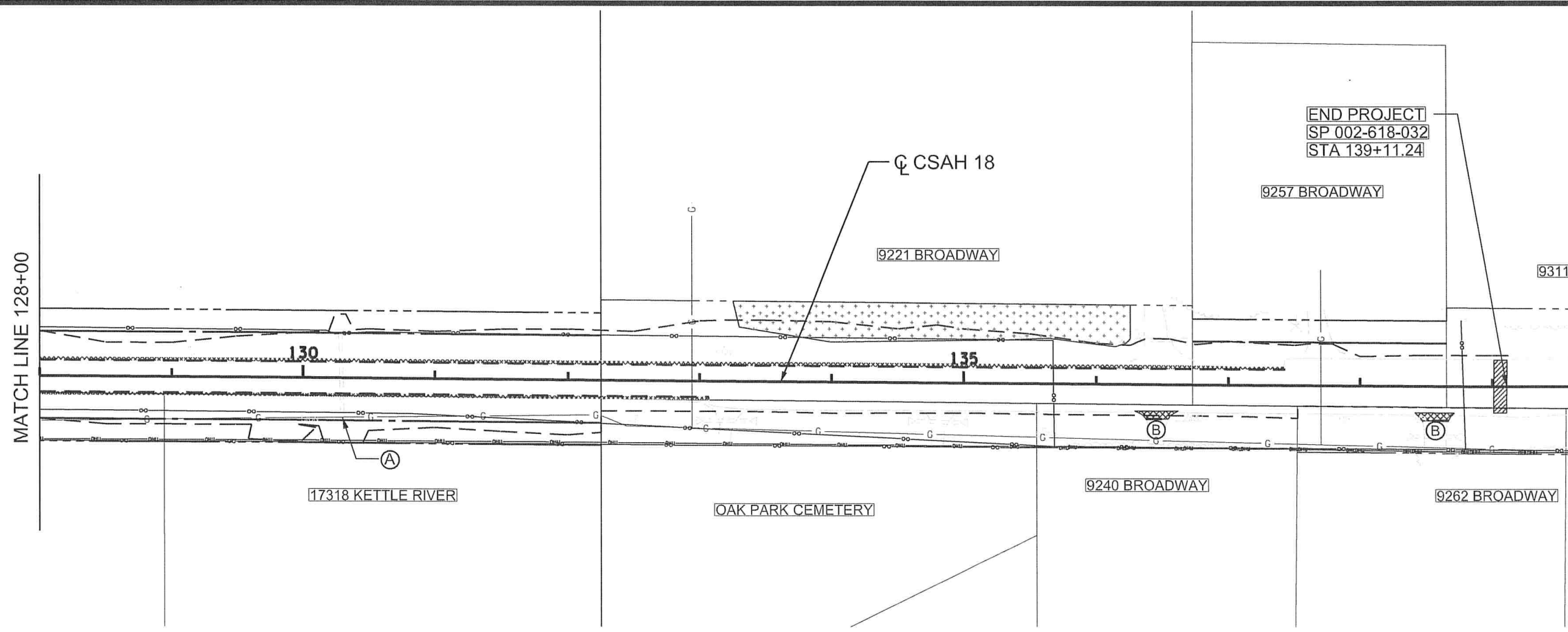
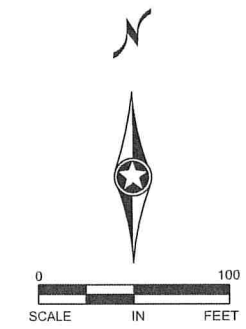

REMOVAL NOTES

THE CONTRACTOR SHALL PERFORM ALL CLEARING AND GRUBBING AS DIRECTED AND MARKED IN THE FIELD BY THE ENGINEER. THE CONTRACTOR SHALL OTHERWISE PROTECT ALL EXISTING TREES NOT SPECIFICALLY MARKED FOR REMOVAL.

ALL PRIVATE UTILITIES TO BE RELOCATED BY OTHERS AS REQUIRED. SEE IN PLACE UTILITY TABULATION FOR MORE INFORMATION.

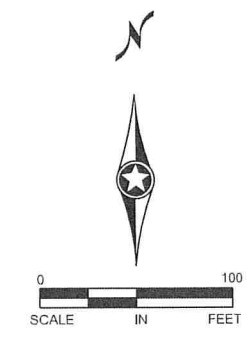

NO	DATE	BY	CKD	APPR	REVISION

NAME: P:\002-618-032\Plan\0261832_REM_P6.dgn 01/29/2019 6:52:00 AM

I HEREBY CERTIFY THAT THIS PLAN WAS PREPARED BY ME OR UNDER MY DIRECT SUPERVISION AND THAT I AM A DULY LICENSED PROFESSIONAL ENGINEER UNDER THE LAWS OF THE STATE OF MINNESOTA.

PRINT NAME: NICHOLAS DOBDA

SIGNATURE: *Nicholas Dobda*

DATE: 2-21-19 LICENSE NO. 49046

DRAWN BY: KT DATE: 10/24/18

DESIGN BY: JCF DATE: 10/24/18

CHECKED BY: NJD DATE: 10/24/18

**ANOKA COUNTY
HIGHWAY DEPT.**

SP 002-618-032

REMOVAL PLAN

STA 117+00.00 TO 139+17.62

Sheet 35 of 126 Sheets

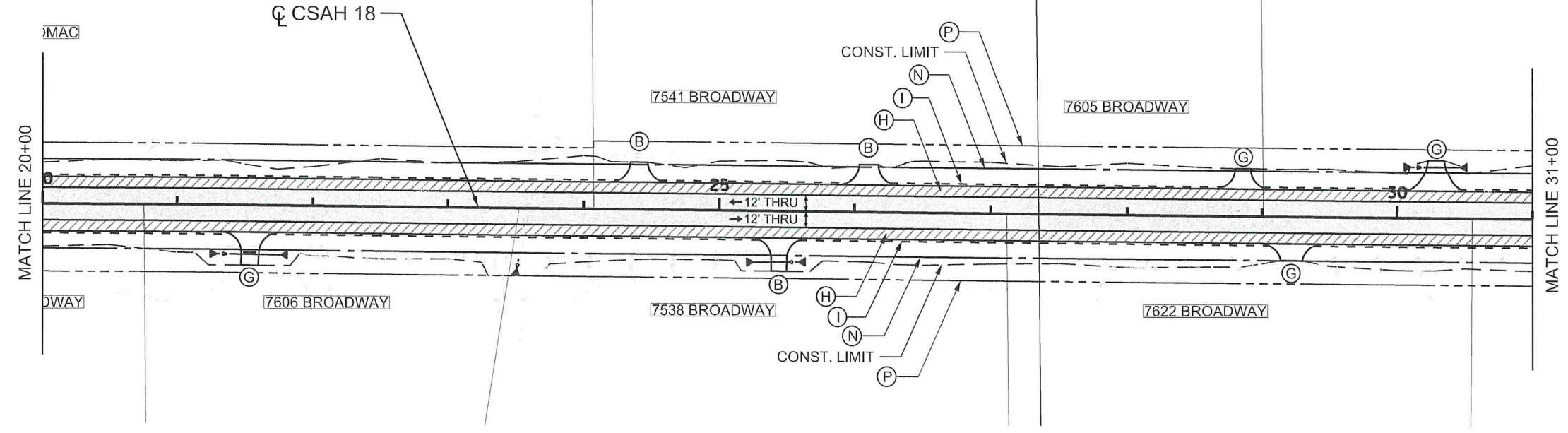

- CONSTRUCTION NOTES:**
- OVERLAY BITUMINOUS PAVEMENT
 - CONSTRUCT BITUMINOUS PAVEMENT
 - BIT. DRIVEWAY / STREET
 - CONCRETE DRIVEWAY
 - GRAVEL DRIVEWAY
 - 8.0' BITUMINOUS SHOULDER
 - 1.5' AGGREGATE SHOULDER
 - NEW R/W
 - PERMANENT EASEMENT
 - PROPOSED CULVERT
 - EXISTING CULVERT
- ALL DIMENSIONS ARE TO EDGE OF PAVEMENT UNLESS OTHERWISE NOTED.

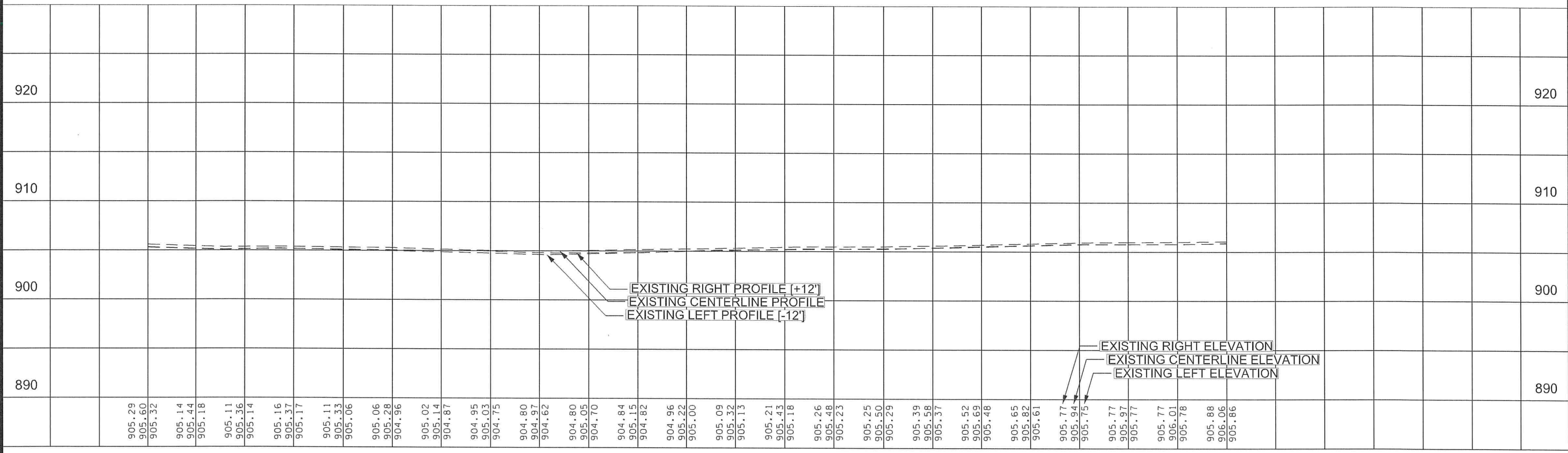
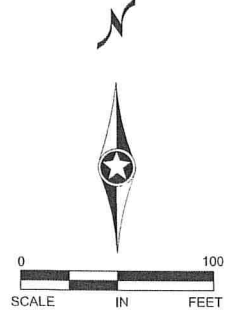

20+00 21+00 22+00 23+00 24+00 25+00 26+00 27+00 28+00 29+00 30+00 31+00

2 OF 12

NO	DATE	BY	CKD	APPR	REVISION

NAME: P:\002-618-032\Plan\0261832_PP2.dgn 01/28/2019 6:52:17 AM

I HEREBY CERTIFY THAT THIS PLAN WAS PREPARED BY ME OR UNDER MY DIRECT SUPERVISION AND THAT I AM A DULY LICENSED PROFESSIONAL ENGINEER UNDER THE LAWS OF THE STATE OF MINNESOTA.

PRINT NAME: NICHOLAS DOBDA
 SIGNATURE:
 DATE: 2-21-19 LICENSE NO. 49046

DRAWN BY: KT DATE: 10/24/18
 DESIGN BY: JCF DATE: 10/24/18
 CHECKED BY: NJD DATE: 10/24/18

ANOKA COUNTY
 HIGHWAY DEPT.

SP 002-618-032

PLAN PROFILE
 STA 20+00.00 TO 31+00.00
 Sheet 37 of 126 Sheets

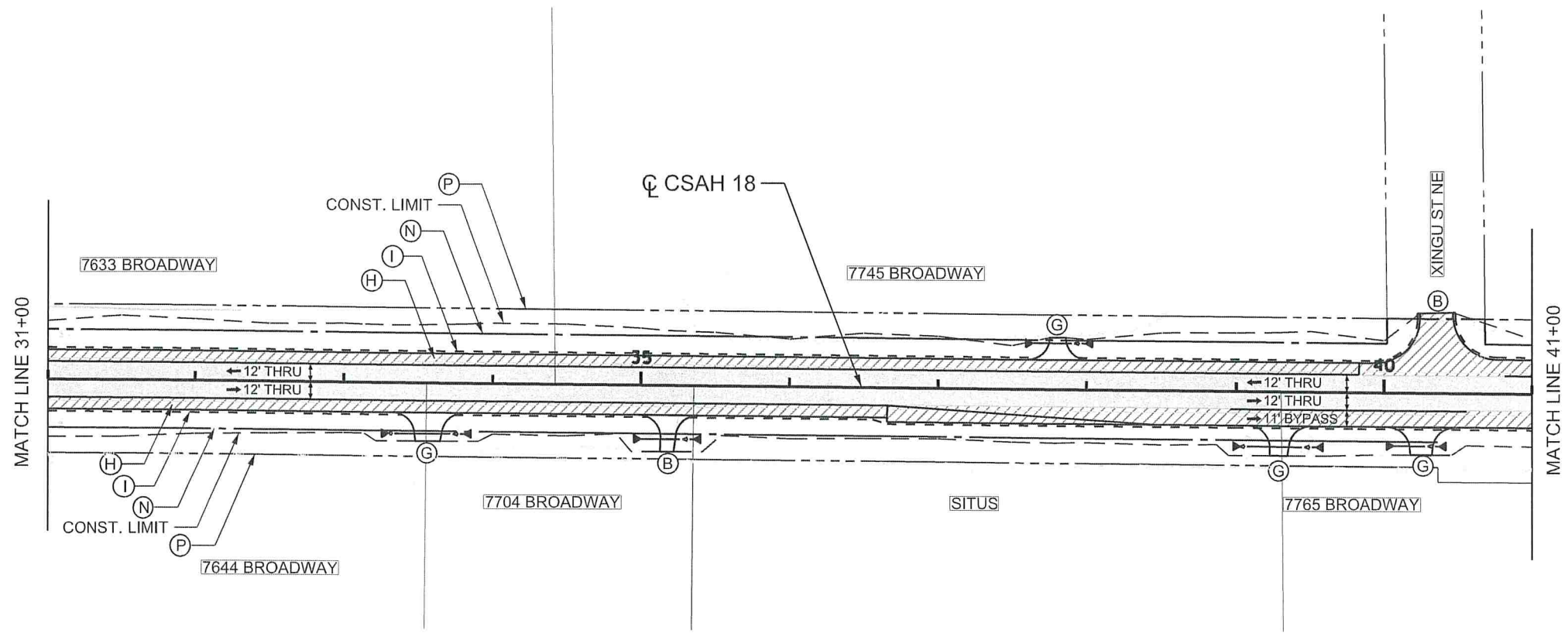

- CONSTRUCTION NOTES:**
- OVERLAY BITUMINOUS PAVEMENT
 - CONSTRUCT BITUMINOUS PAVEMENT
 - BIT. DRIVEWAY / STREET
 - CONCRETE DRIVEWAY
 - GRAVEL DRIVEWAY
 - 8.0' BITUMINOUS SHOULDER
 - 1.5' AGGREGATE SHOULDER
 - NEW R/W
 - PERMANENT EASEMENT
 - PROPOSED CULVERT
 - EXISTING CULVERT
- ALL DIMENSIONS ARE TO EDGE OF PAVEMENT UNLESS OTHERWISE NOTED.

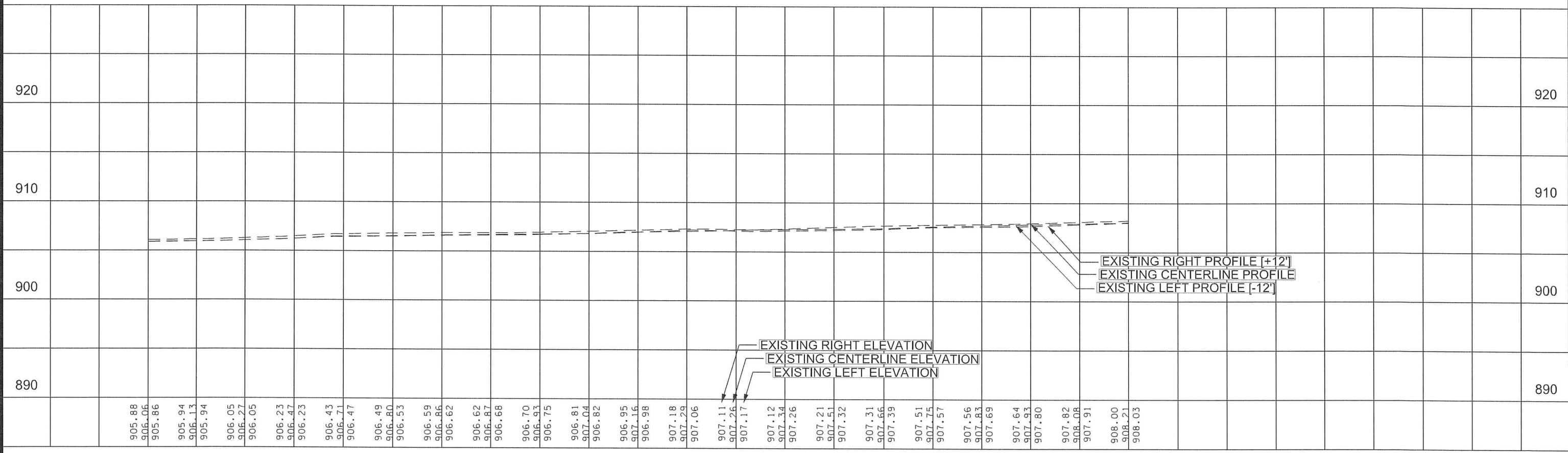
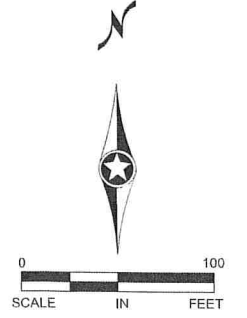

31+00 32+00 33+00 34+00 35+00 36+00 37+00 38+00 39+00 40+00 41+00

3 OF 12

NO	DATE	BY	CKD	APPR	REVISION

NAME: P:\002-618-032\Plan\0261832_PP3.dgn 01/28/2019 6:52:20 AM

I HEREBY CERTIFY THAT THIS PLAN WAS PREPARED BY ME OR UNDER MY DIRECT SUPERVISION AND THAT I AM A DULY LICENSED PROFESSIONAL ENGINEER UNDER THE LAWS OF THE STATE OF MINNESOTA.

PRINT NAME: NICHOLAS DOBDA

SIGNATURE: *Nicholas Dobda*

DATE: 2-21-19 LICENSE NO. 49046

DRAWN BY: KT DATE: 10/24/18

DESIGN BY: JCF DATE: 10/24/18

CHECKED BY: NJD DATE: 10/24/18

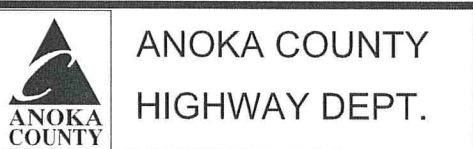

SP 002-618-032

PLAN PROFILE

STA 31+00.00 TO 41+00.00

Sheet 38 of 126 Sheets

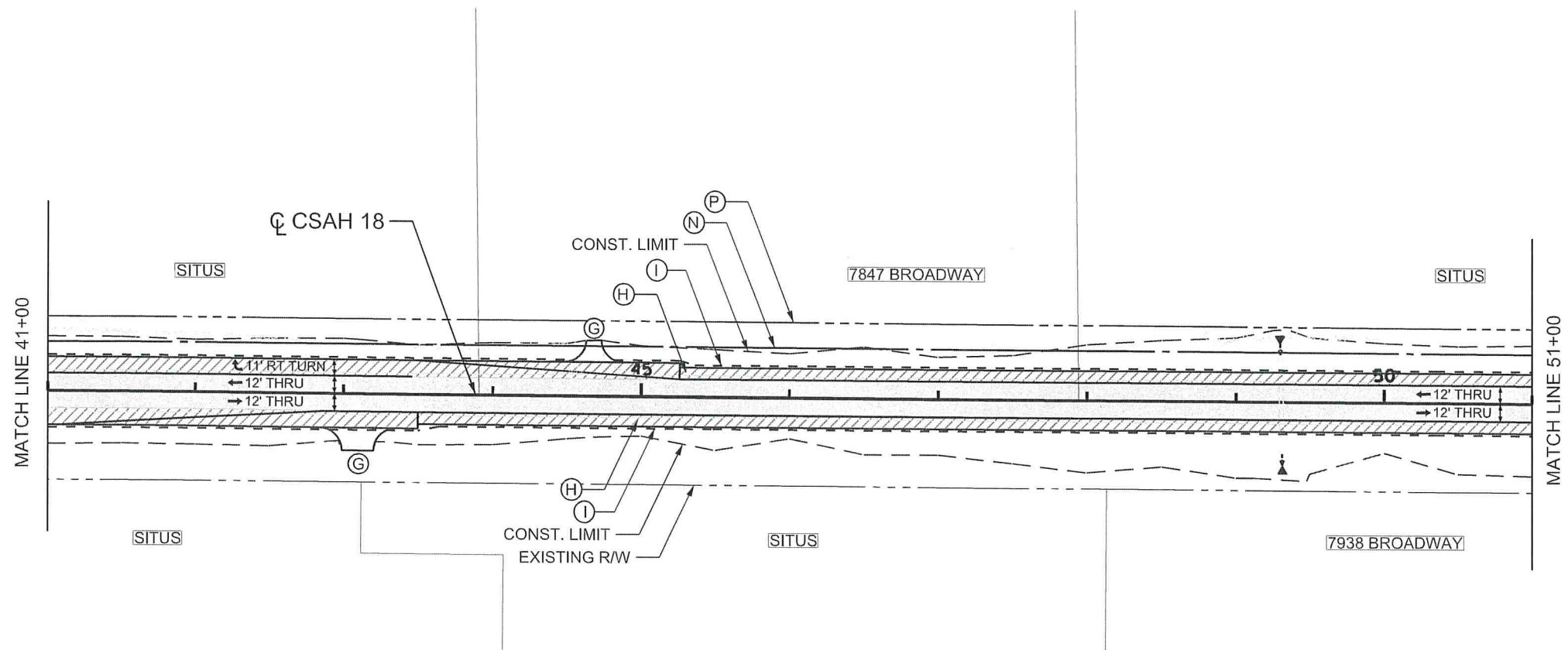

- CONSTRUCTION NOTES:**
- OVERLAY BITUMINOUS PAVEMENT
 - CONSTRUCT BITUMINOUS PAVEMENT
 - BIT. DRIVEWAY / STREET
 - CONCRETE DRIVEWAY
 - GRAVEL DRIVEWAY
 - 8.0' BITUMINOUS SHOULDER
 - 1.5' AGGREGATE SHOULDER
 - NEW R/W
 - PERMANENT EASEMENT
 - PROPOSED CULVERT
 - EXISTING CULVERT
- ALL DIMENSIONS ARE TO EDGE OF PAVEMENT UNLESS OTHERWISE NOTED.

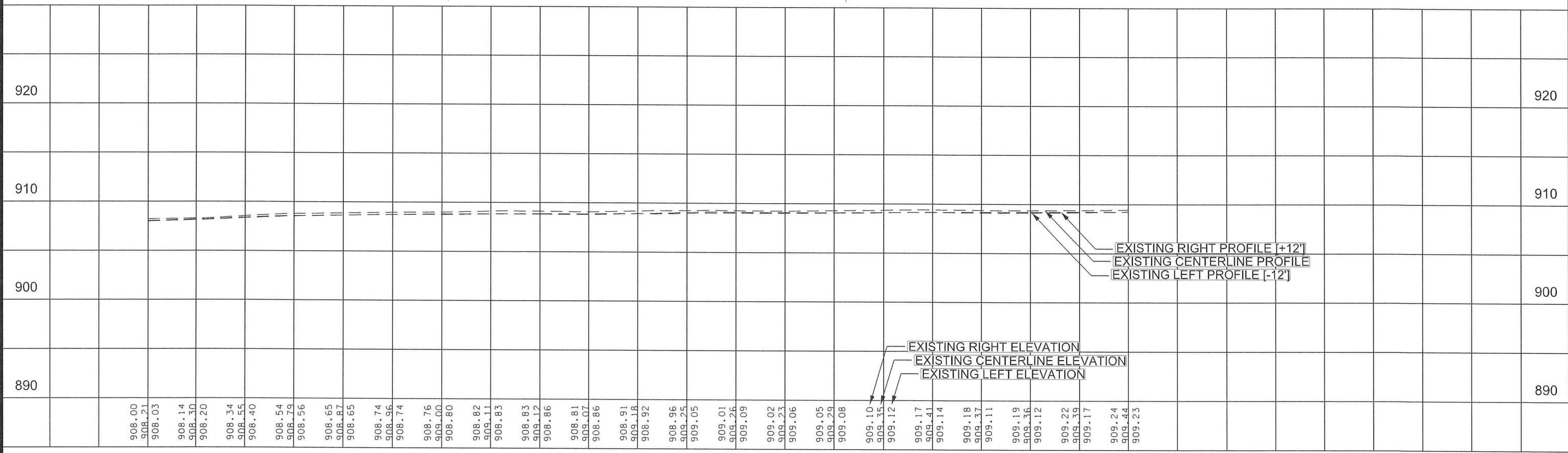
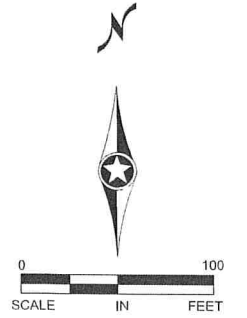

908.00	908.21	908.03	908.14	908.30	908.20	908.34	908.55	908.40	908.54	908.79	908.56	908.65	908.87	908.65	908.74	908.96	908.74	908.76	909.00	908.80	908.82	909.11	908.83	908.83	909.12	908.86	908.81	909.07	908.86	908.91	909.18	908.92	908.96	909.25	909.05	909.01	909.26	909.09	909.02	909.23	909.06	909.05	909.29	909.08	909.10	909.35	909.12	909.17	909.41	909.14	909.18	909.37	909.11	909.19	909.36	909.12	909.22	909.39	909.17	909.24	909.44	909.23
41+00		42+00		43+00		44+00		45+00		46+00		47+00		48+00		49+00		50+00		51+00																																										

NO	DATE	BY	CKD	APPR	REVISION

NAME: P:\002-618-032\Plan\0261832_PP4.dgn 01/28/2019 6:52:22 AM

I HEREBY CERTIFY THAT THIS PLAN WAS PREPARED BY ME OR UNDER MY DIRECT SUPERVISION AND THAT I AM A DULY LICENSED PROFESSIONAL ENGINEER UNDER THE LAWS OF THE STATE OF MINNESOTA.

PRINT NAME: NICHOLAS DOBDA

SIGNATURE:

DATE: 2-21-19 LICENSE NO. 49046

DRAWN BY: KT DATE: 10/24/18

DESIGN BY: JCF DATE: 10/24/18

CHECKED BY: NJD DATE: 10/24/18

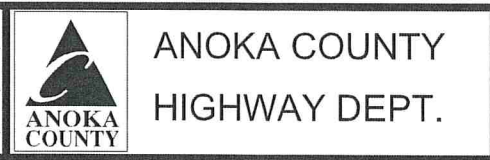

SP 002-618-032

PLAN PROFILE

STA 41+00.00 TO 51+00.00

Sheet 39 of 126 Sheets

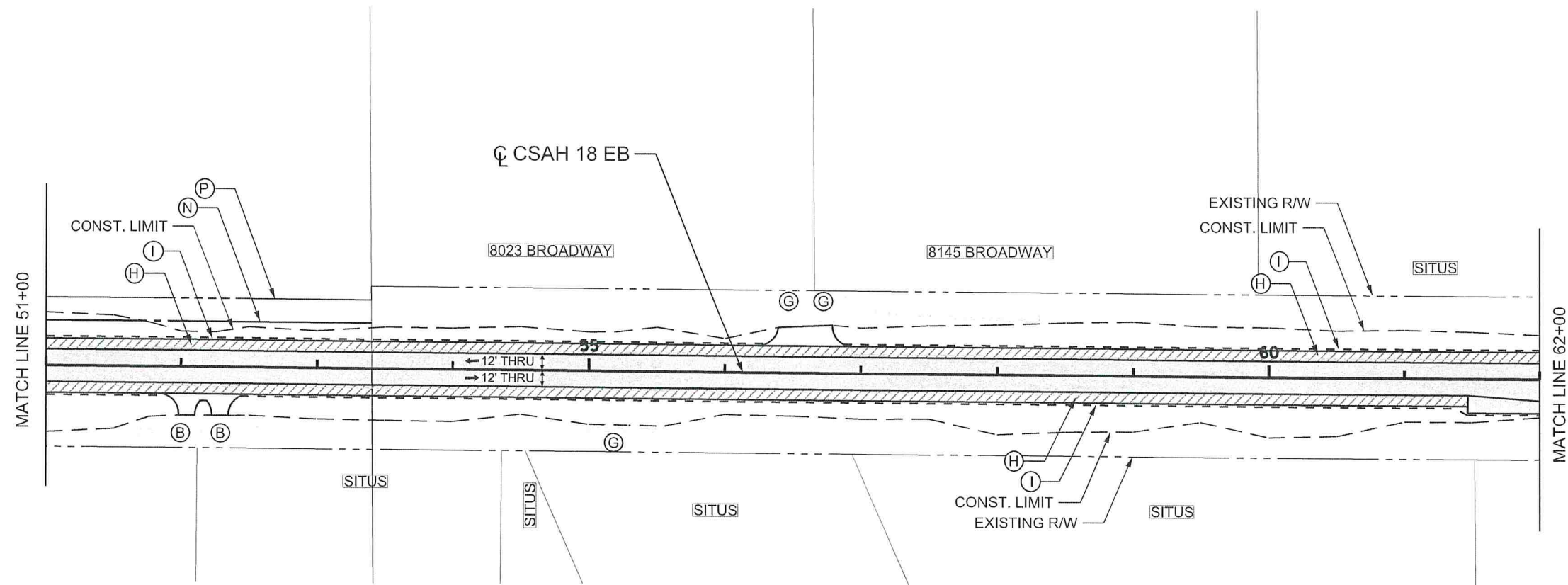

- CONSTRUCTION NOTES:**
- OVERLAY BITUMINOUS PAVEMENT
 - CONSTRUCT BITUMINOUS PAVEMENT
 - BIT. DRIVEWAY / STREET
 - CONCRETE DRIVEWAY
 - GRAVEL DRIVEWAY
 - 8.0' BITUMINOUS SHOULDER
 - 1.5' AGGREGATE SHOULDER
 - NEW R/W
 - PERMANENT EASEMENT
 - PROPOSED CULVERT
 - EXISTING CULVERT
- ALL DIMENSIONS ARE TO EDGE OF PAVEMENT UNLESS OTHERWISE NOTED.

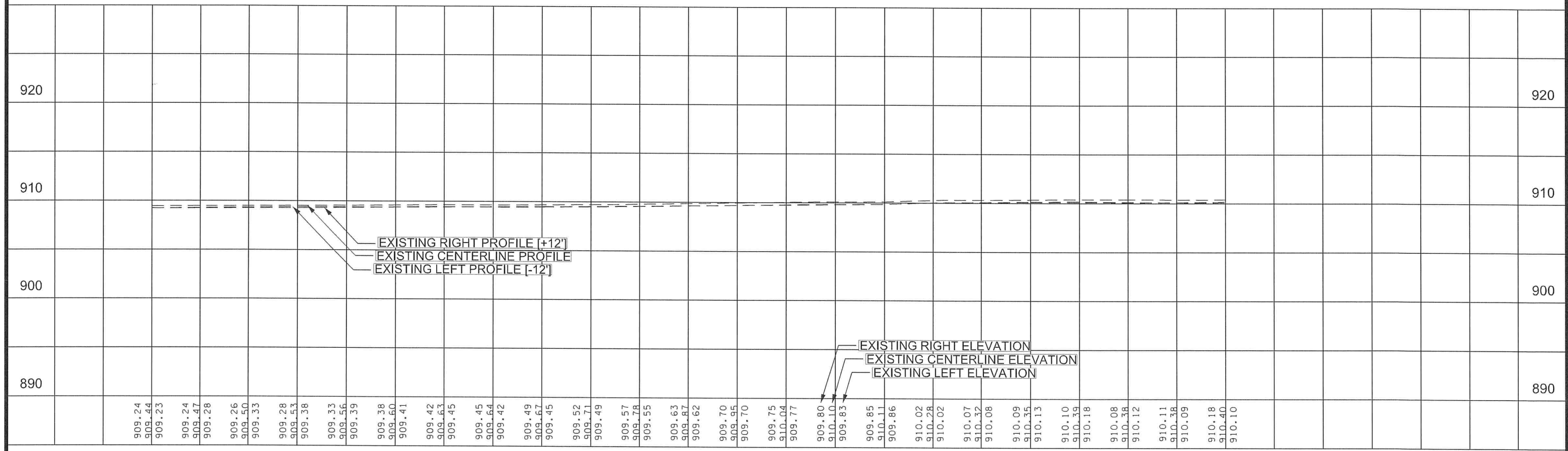
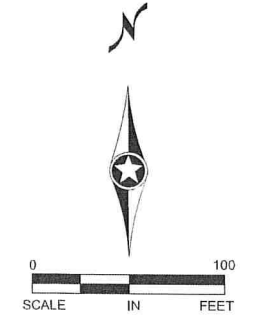

909.24	909.44	909.23	909.24	909.47	909.28	909.26	909.50	909.33	909.28	909.53	909.38	909.56	909.39	909.38	909.60	909.41	909.42	909.63	909.45	909.45	909.64	909.42	909.49	909.67	909.45	909.52	909.71	909.49	909.57	909.78	909.55	909.63	909.87	909.62	909.70	909.95	909.70	909.75	910.04	909.77	909.80	910.10	909.83	909.85	910.11	909.86	910.02	910.28	910.02	910.07	910.32	910.08	910.09	910.35	910.13	910.10	910.39	910.18	910.08	910.38	910.12	910.11	910.38	910.09	910.18	910.40	910.10
51+00	52+00	53+00	54+00	55+00	56+00	57+00	58+00	59+00	60+00	61+00	62+00																																																								

NO	DATE	BY	CHKD	APPR	REVISION

NAME: P:\002-618-032\Plan\0261832_PP5.dgn 01/28/2019 6:52:24 AM

I HEREBY CERTIFY THAT THIS PLAN WAS PREPARED BY ME OR UNDER MY DIRECT SUPERVISION AND THAT I AM A DULY LICENSED PROFESSIONAL ENGINEER UNDER THE LAWS OF THE STATE OF MINNESOTA.

PRINT NAME: NICHOLAS DOBDA

SIGNATURE:

DATE: 2-21-19 LICENSE NO. 49046

DRAWN BY KT DATE 10/24/18

DESIGN BY JCF DATE 10/24/18

CHECKED BY NJD DATE 10/24/18











ANOKA COUNTY
HIGHWAY DEPT.

SP 002-618-032

PLAN PROFILE

STA 51+00.00 TO 62+00.00

Sheet 40 of 126 Sheets

- CONSTRUCTION NOTES:**
-  OVERLAY BITUMINOUS PAVEMENT
 -  CONSTRUCT BITUMINOUS PAVEMENT
 -  BIT. DRIVEWAY / STREET
 -  CONCRETE DRIVEWAY
 -  GRAVEL DRIVEWAY
 -  8.0' BITUMINOUS SHOULDER
 -  1.5' AGGREGATE SHOULDER
 -  NEW R/W
 -  PERMANENT EASEMENT
 -  PROPOSED CULVERT
 -  EXISTING CULVERT
- ALL DIMENSIONS ARE TO EDGE OF PAVEMENT UNLESS OTHERWISE NOTED.

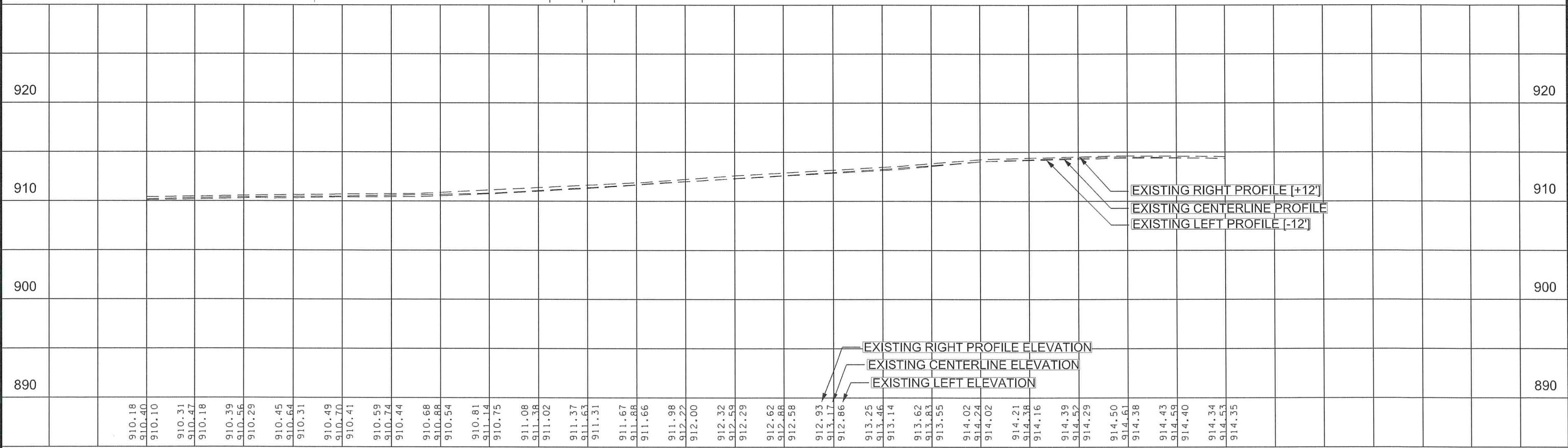
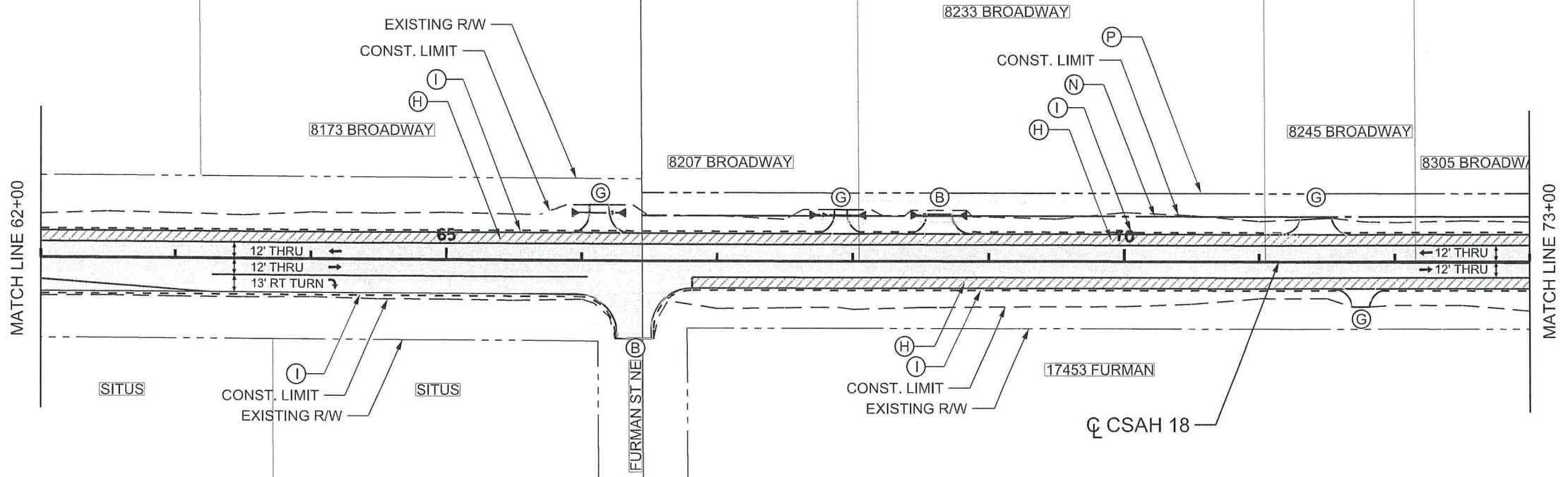
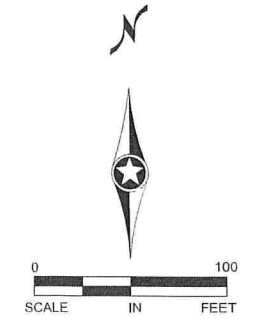

62+00 63+00 64+00 65+00 66+00 67+00 68+00 69+00 70+00 71+00 72+00 73+00

6 OF 12

NO	DATE	BY	CHKD	APPR	REVISION

NAME: P:\002-618-032\Plan\0261832_PP6.dgn 01/29/2019 6:52:25 AM

I HEREBY CERTIFY THAT THIS PLAN WAS PREPARED BY ME OR UNDER MY DIRECT SUPERVISION AND THAT I AM A DULY LICENSED PROFESSIONAL ENGINEER UNDER THE LAWS OF THE STATE OF MINNESOTA.

PRINT NAME: NICHOLAS DOBDA

SIGNATURE: *Nicholas Dobda*

DATE: 2-21-19 LICENSE NO. 49046

DRAWN BY: KT DATE: 10/24/18

DESIGN BY: JCF DATE: 10/24/18

CHECKED BY: NJD DATE: 10/24/18



ANOKA COUNTY
HIGHWAY DEPT.

SP 002-618-032

PLAN PROFILE
STA 62+00.00 TO 73+00.00

Sheet 41 of 126 Sheets

- CONSTRUCTION NOTES:**
- OVERLAY BITUMINOUS PAVEMENT
 - CONSTRUCT BITUMINOUS PAVEMENT
 - (B) BIT. DRIVEWAY / STREET
 - (C) CONCRETE DRIVEWAY
 - (G) GRAVEL DRIVEWAY
 - (H) 8.0' BITUMINOUS SHOULDER
 - (I) 1.5' AGGREGATE SHOULDER
 - (N) NEW R/W
 - (P) PERMANENT EASEMENT
 - PROPOSED CULVERT
 - EXISTING CULVERT
- ALL DIMENSIONS ARE TO EDGE OF PAVEMENT UNLESS OTHERWISE NOTED.

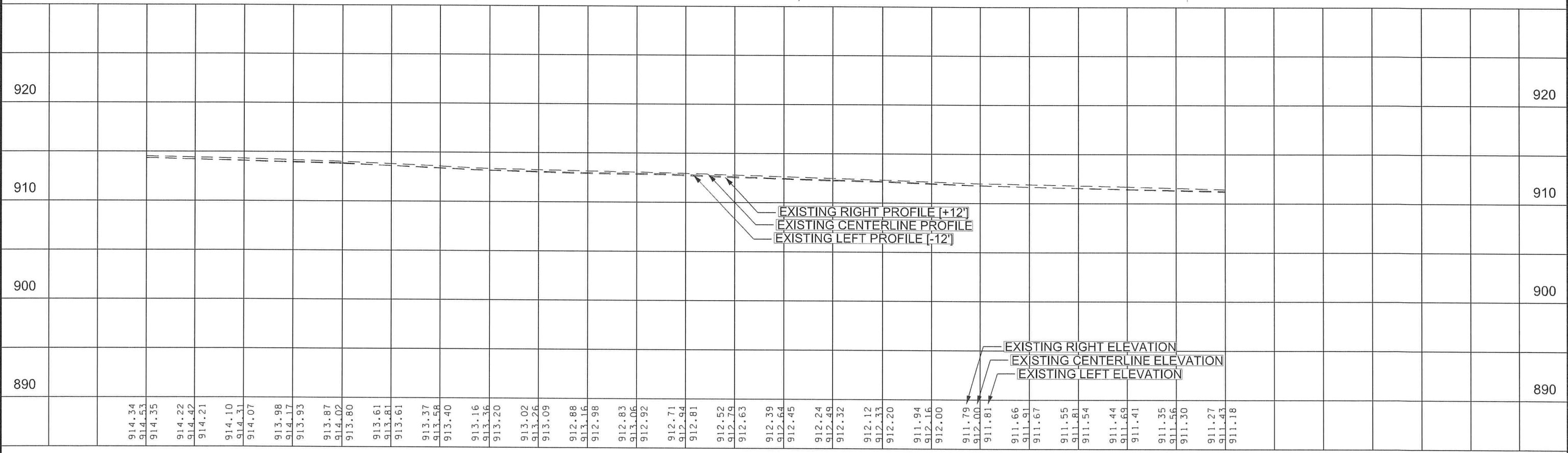
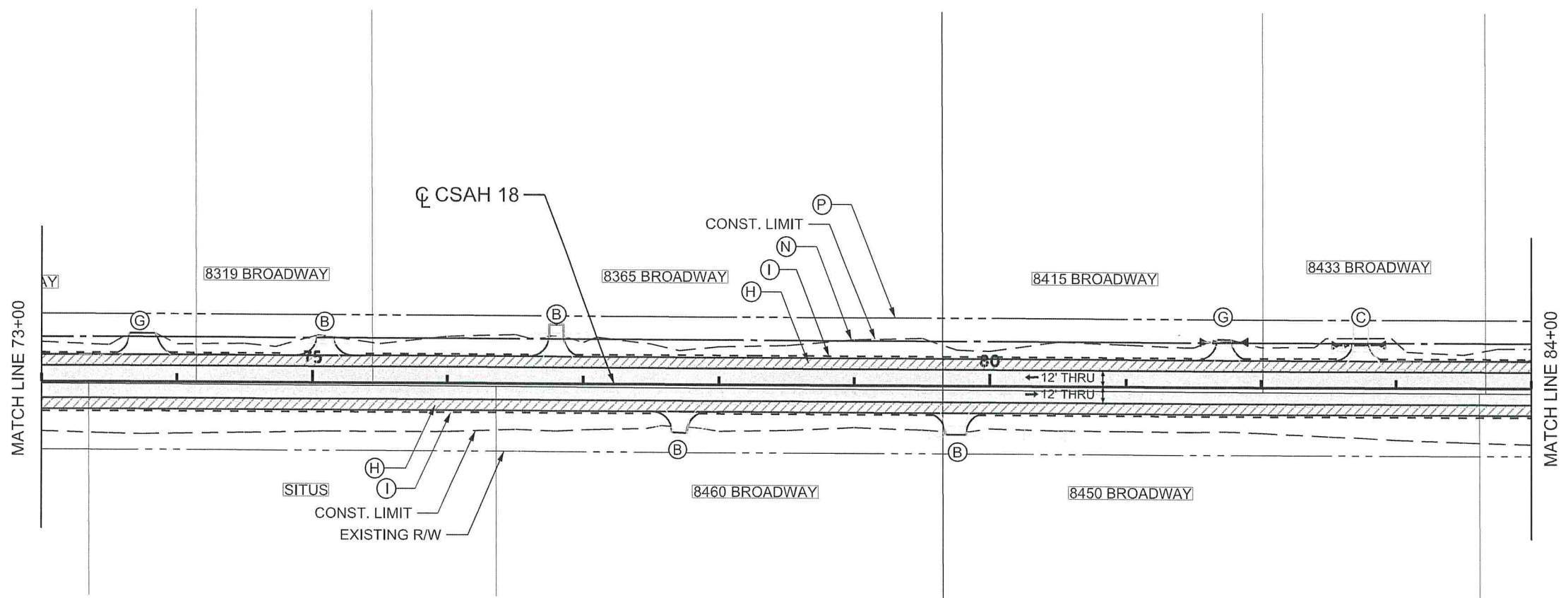
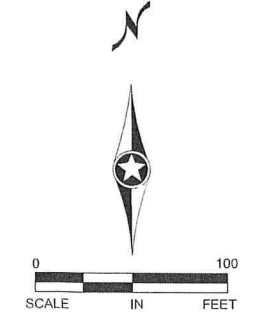

73+00 74+00 75+00 76+00 77+00 78+00 79+00 80+00 81+00 82+00 83+00 84+00

7 OF 12

NO	DATE	BY	CHKD	APPR	REVISION

NAME: P:\002-618-032\Plan\0261832_PP7.dgn 01/28/2019 6:52:27 AM

I HEREBY CERTIFY THAT THIS PLAN WAS PREPARED BY ME OR UNDER MY DIRECT SUPERVISION AND THAT I AM A DULY LICENSED PROFESSIONAL ENGINEER UNDER THE LAWS OF THE STATE OF MINNESOTA.

PRINT NAME: NICHOLAS DOBDA
 SIGNATURE: *[Signature]*
 DATE: 2-21-19 LICENSE NO. 49046

DRAWN BY: KT DATE: 10/24/18
 DESIGN BY: JCF DATE: 10/24/18
 CHECKED BY: NJD DATE: 10/24/18

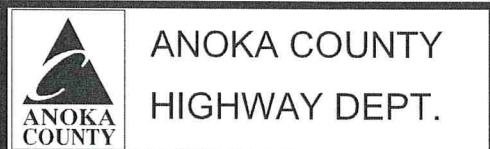











SP 002-618-032

PLAN PROFILE

STA 73+00.00 TO 84+00.00

Sheet 42 of 126 Sheets

- CONSTRUCTION NOTES:**
-  OVERLAY BITUMINOUS PAVEMENT
 -  CONSTRUCT BITUMINOUS PAVEMENT
 -  BIT. DRIVEWAY / STREET
 -  CONCRETE DRIVEWAY
 -  GRAVEL DRIVEWAY
 -  8.0' BITUMINOUS SHOULDER
 -  1.5' AGGREGATE SHOULDER
 -  NEW R/W
 -  PERMANENT EASEMENT
 -  PROPOSED CULVERT
 -  EXISTING CULVERT
- ALL DIMENSIONS ARE TO EDGE OF PAVEMENT UNLESS OTHERWISE NOTED.

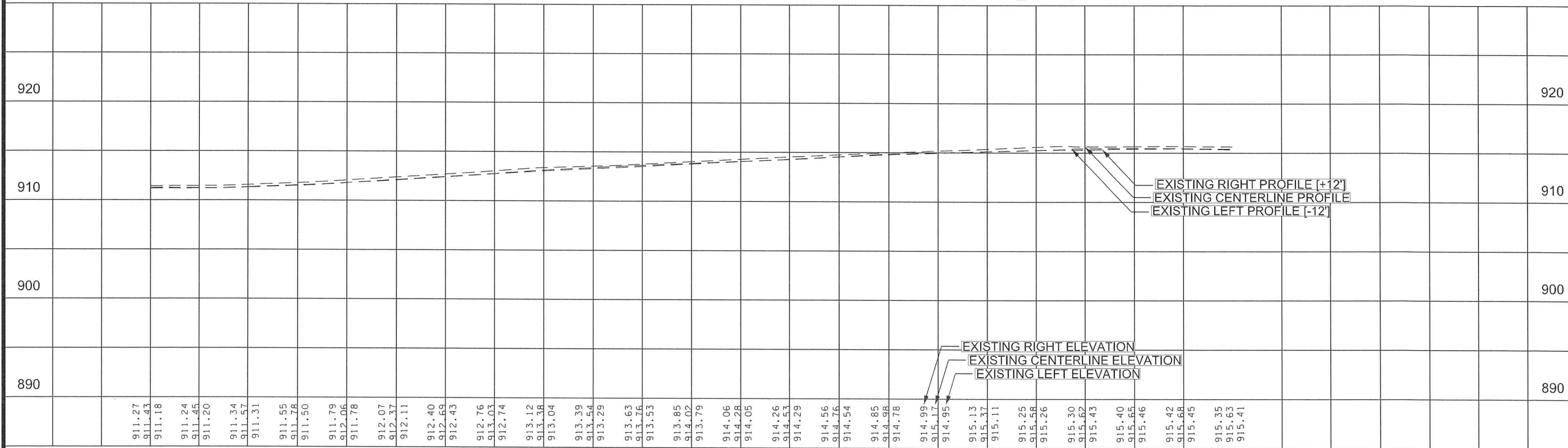
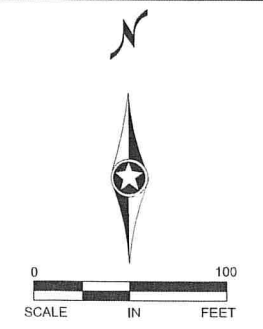
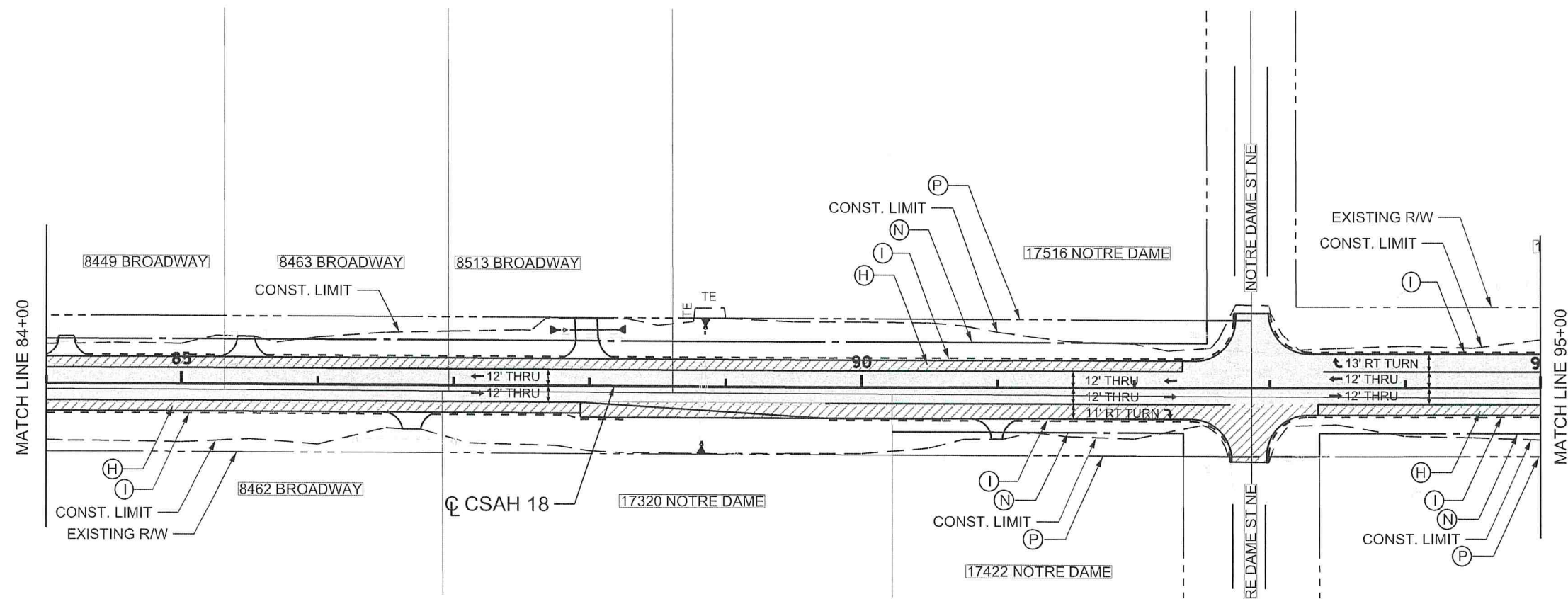

84+00	85+00	86+00	87+00	88+00	89+00	90+00	91+00	92+00	93+00	94+00	95+00
-------	-------	-------	-------	-------	-------	-------	-------	-------	-------	-------	-------

NO	DATE	BY	CKD	APPR	REVISION

NAME: P:\002-618-032\Plan\0261832_PP8.dgn 01/28/2019 6:52:28 AM

I HEREBY CERTIFY THAT THIS PLAN WAS PREPARED BY ME OR UNDER MY DIRECT SUPERVISION AND THAT I AM A DULY LICENSED PROFESSIONAL ENGINEER UNDER THE LAWS OF THE STATE OF MINNESOTA.

PRINT NAME: NICHOLAS DOBDA

SIGNATURE: *Nicholas Dobda*

DATE: 2-21-19 LICENSE NO. 49046

DRAWN BY: KT DATE: 10/24/18

DESIGN BY: JCF DATE: 10/24/18

CHECKED BY: NJD DATE: 10/24/18

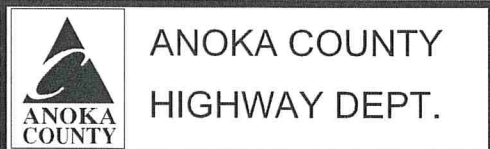











SP 002-618-032

PLAN PROFILE

STA 84+00.00 TO 95+00.00

Sheet 43 of 126 Sheets

- CONSTRUCTION NOTES:**
-  OVERLAY BITUMINOUS PAVEMENT
 -  CONSTRUCT BITUMINOUS PAVEMENT
 -  BIT. DRIVEWAY / STREET
 -  CONCRETE DRIVEWAY
 -  GRAVEL DRIVEWAY
 -  8.0' BITUMINOUS SHOULDER
 -  1.5' AGGREGATE SHOULDER
 -  NEW R/W
 -  PERMANENT EASEMENT
 -  PROPOSED CULVERT
 -  EXISTING CULVERT
- ALL DIMENSIONS ARE TO EDGE OF PAVEMENT UNLESS OTHERWISE NOTED.

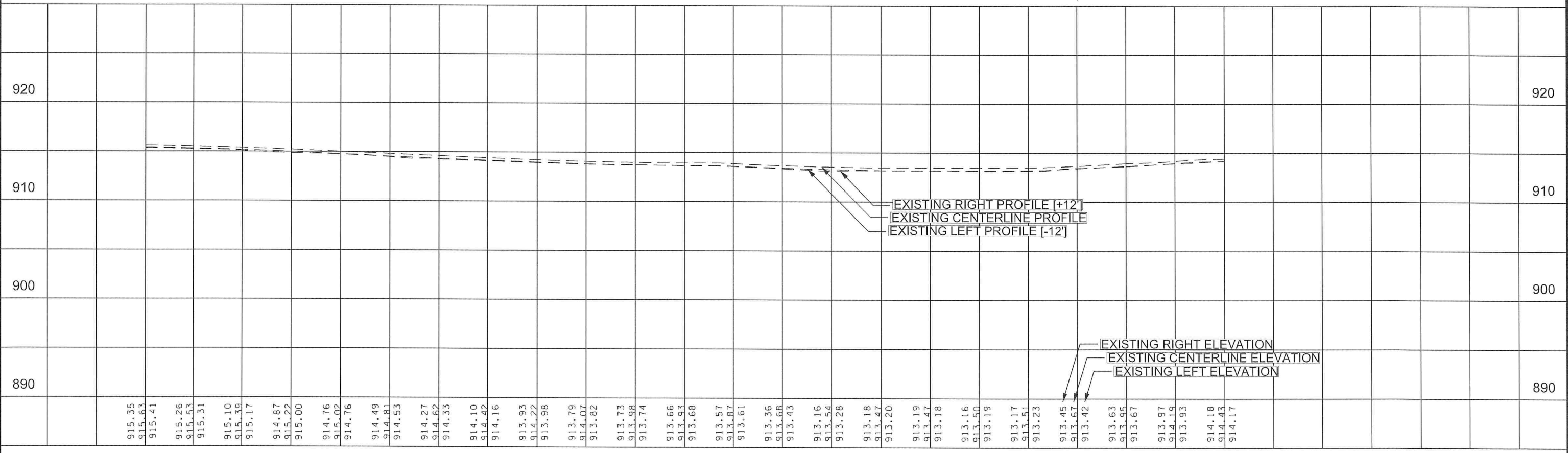
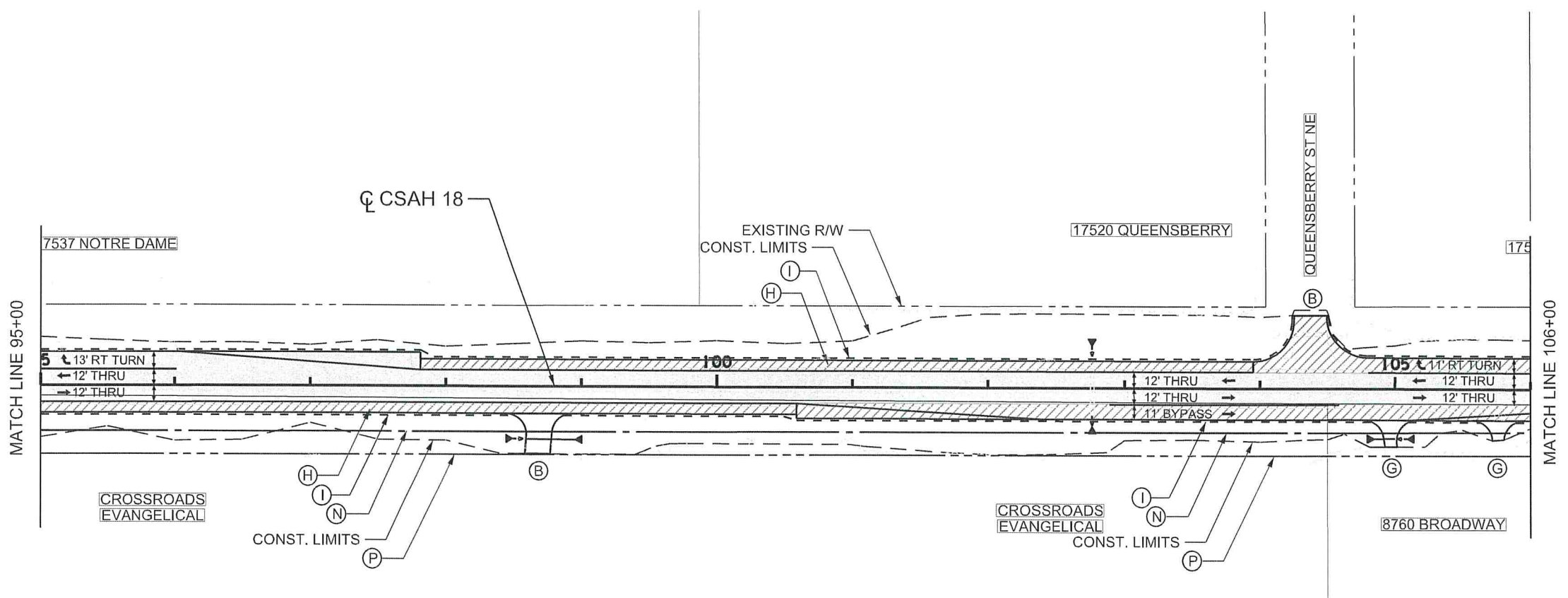
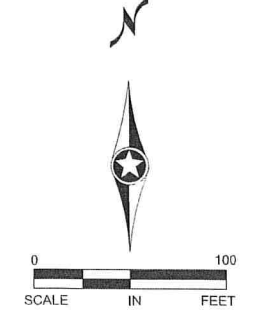

95+00 96+00 97+00 98+00 99+00 100+00 101+00 102+00 103+00 104+00 105+00 106+00

9 OF 12

NO	DATE	BY	CHKD	APPR	REVISION

NAME: P:\002-618-032\Plan\0261832_PP9.dgn 01/28/2019 6:52:30 AM

I HEREBY CERTIFY THAT THIS PLAN WAS PREPARED BY ME OR UNDER MY DIRECT SUPERVISION AND THAT I AM A DULY LICENSED PROFESSIONAL ENGINEER UNDER THE LAWS OF THE STATE OF MINNESOTA.

PRINT NAME: NICHOLAS DOBDA

SIGNATURE: *[Signature]*

DATE: 2-21-19 LICENSE NO. 49046

DRAWN BY: KT DATE: 10/24/18

DESIGN BY: JCF DATE: 10/24/18

CHECKED BY: NJD DATE: 10/24/18

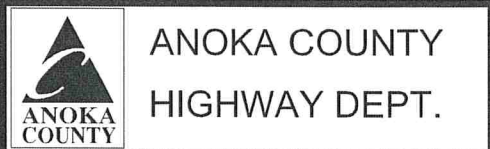











ANOKA COUNTY
HIGHWAY DEPT.

SP 002-618-032

PLAN PROFILE

STA 95+00.00 TO 106+00.00

Sheet 44 of 126 Sheets

- CONSTRUCTION NOTES:**
-  OVERLAY BITUMINOUS PAVEMENT
 -  CONSTRUCT BITUMINOUS PAVEMENT
 -  BIT. DRIVEWAY / STREET
 -  CONCRETE DRIVEWAY
 -  GRAVEL DRIVEWAY
 -  8.0' BITUMINOUS SHOULDER
 -  1.5' AGGREGATE SHOULDER
 -  NEW R/W
 -  PERMANENT EASEMENT
 -  PROPOSED CULVERT
 -  EXISTING CULVERT
- ALL DIMENSIONS ARE TO EDGE OF PAVEMENT UNLESS OTHERWISE NOTED.

WARNING
HIGH-PRESSURE PIPELINE(S)
 Excavation and/or Construction Prohibited
 Without compliance with State One-Call,
AND
 Without Written Permission From
 Magellan Pipeline Company.

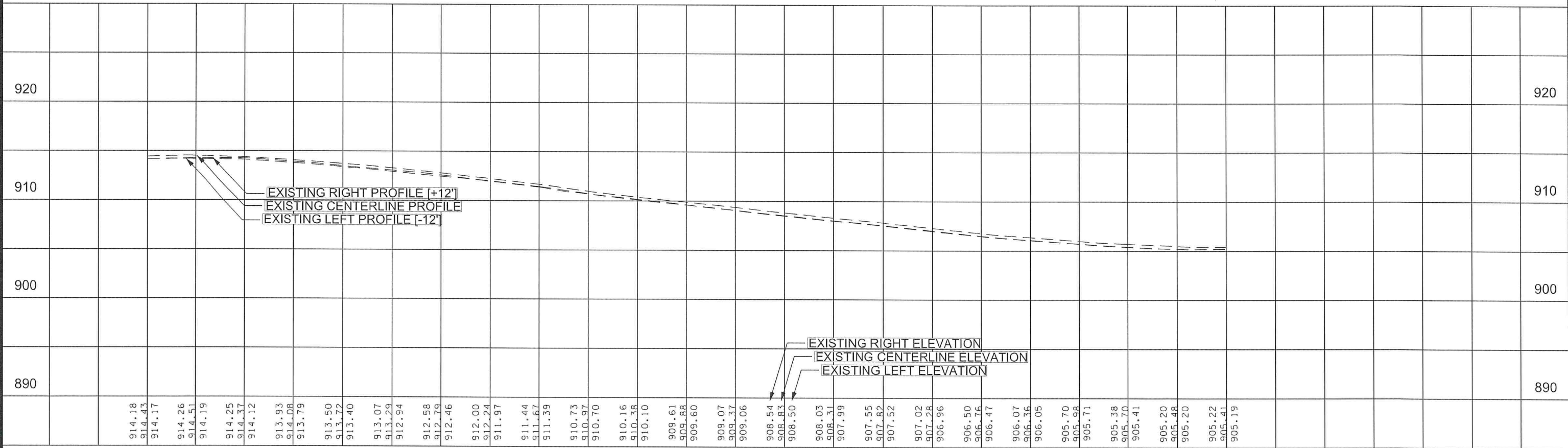
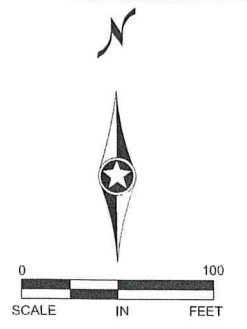
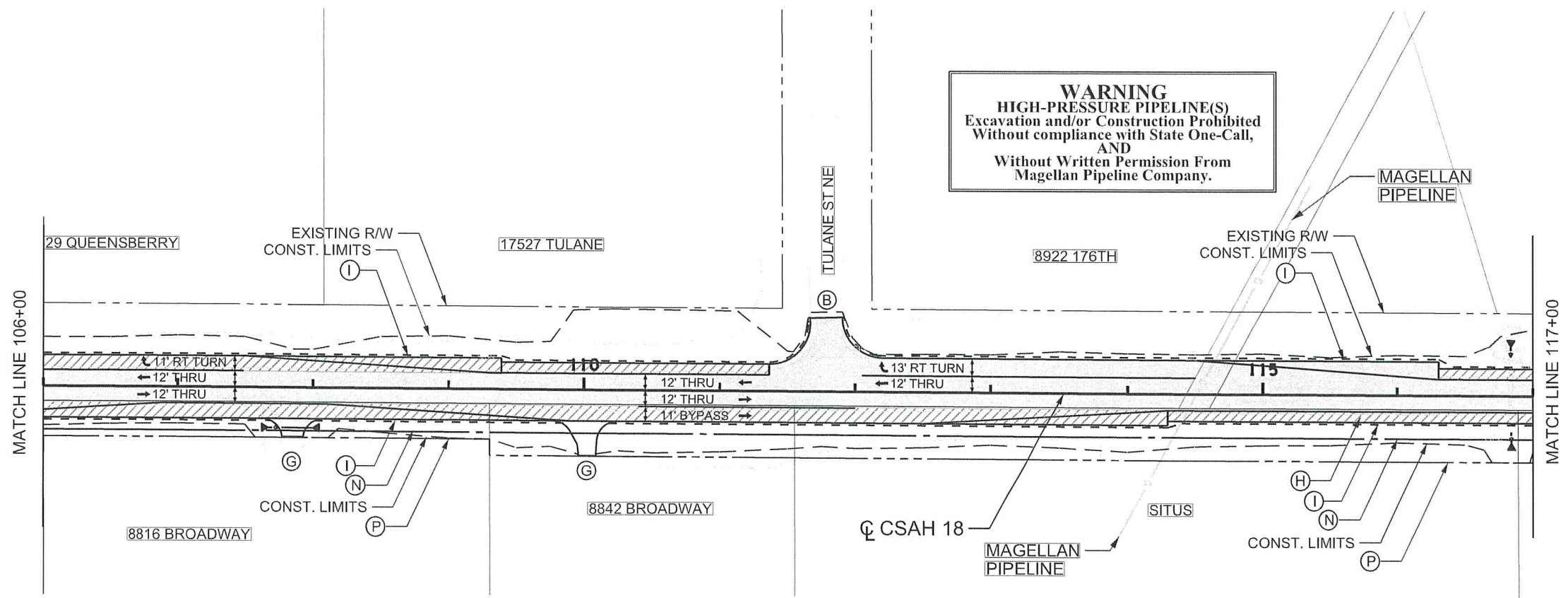

106+00 107+00 108+00 109+00 110+00 111+00 112+00 113+00 114+00 115+00 116+00 117+00

10 OF 12

NO	DATE	BY	CKD	APPR	REVISION

NAME: P:\002-618-032\Plan\0261832_PP10.dgn 01/28/2019 6:52:32 AM

I HEREBY CERTIFY THAT THIS PLAN WAS PREPARED BY ME OR UNDER MY DIRECT SUPERVISION AND THAT I AM A DULY LICENSED PROFESSIONAL ENGINEER UNDER THE LAWS OF THE STATE OF MINNESOTA.

PRINT NAME: NICHOLAS DOBDA

SIGNATURE: *[Signature]*

DATE: 2-21-19 LICENSE NO. 49046

DRAWN BY: KT DATE: 10/24/18

DESIGN BY: JCF DATE: 10/24/18

CHECKED BY: NJD DATE: 10/24/18

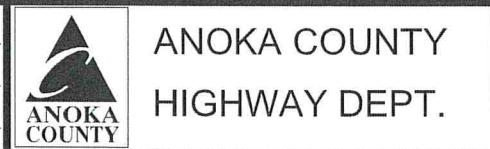











SP 002-618-032

PLAN PROFILE

STA 106+00.00 TO 117+00.00

Sheet 45 of 126 Sheets

- CONSTRUCTION NOTES:**
-  OVERLAY BITUMINOUS PAVEMENT
 -  CONSTRUCT BITUMINOUS PAVEMENT
 -  BIT. DRIVEWAY / STREET
 -  CONCRETE DRIVEWAY
 -  GRAVEL DRIVEWAY
 -  8.0' BITUMINOUS SHOULDER
 -  1.5' AGGREGATE SHOULDER
 -  NEW R/W
 -  PERMANENT EASEMENT
 -  PROPOSED CULVERT
 -  EXISTING CULVERT
- ALL DIMENSIONS ARE TO EDGE OF PAVEMENT UNLESS OTHERWISE NOTED.

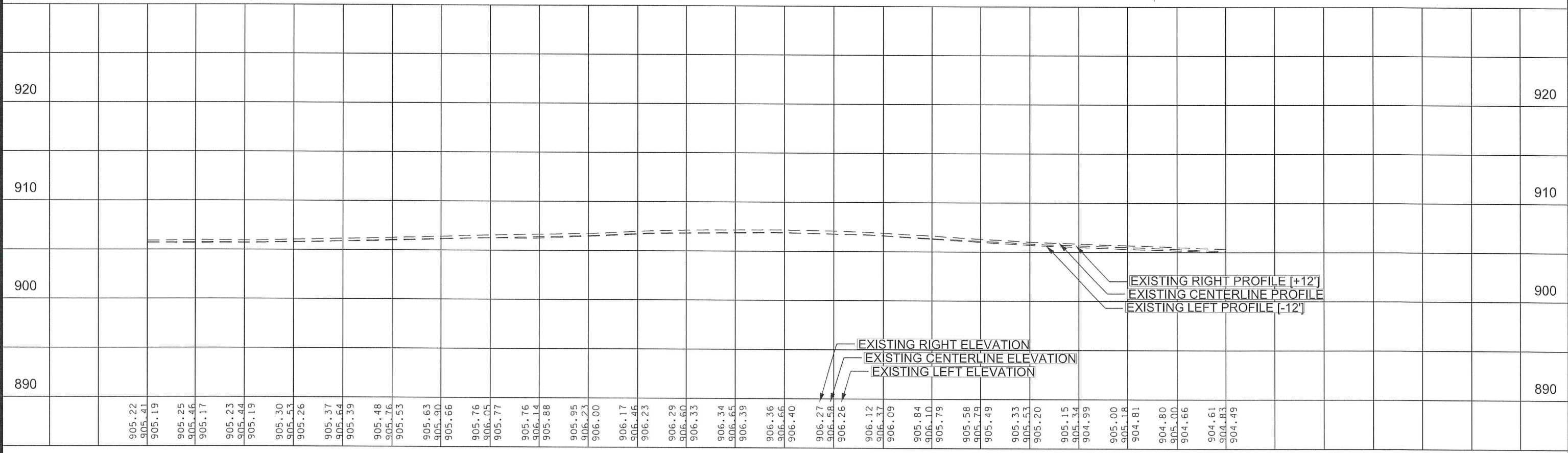
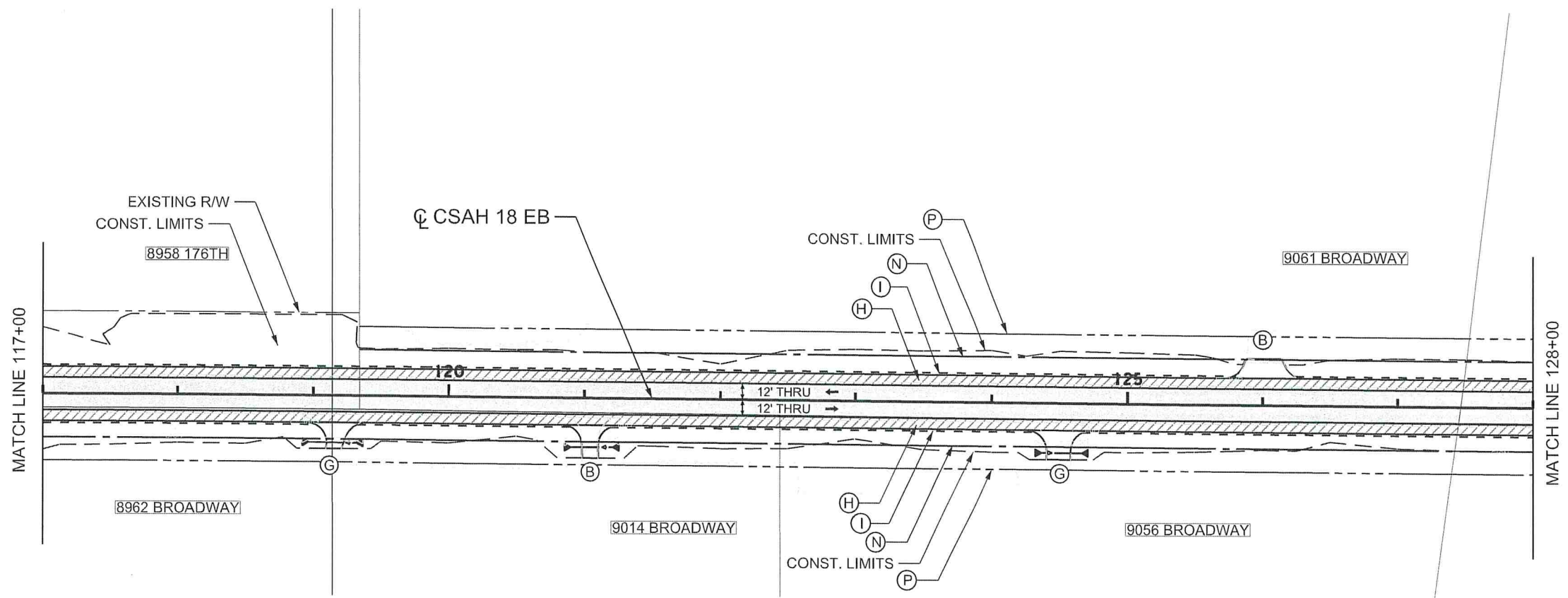
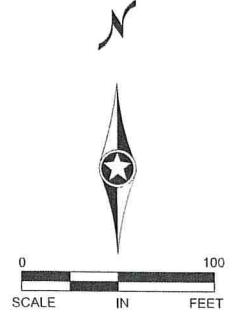

117+00 118+00 119+00 120+00 121+00 122+00 123+00 124+00 125+00 126+00 127+00 128+00

NO	DATE	BY	CKD	APPR	REVISION

NAME: P:\002-618-032\Plan\0261832_PP11.dgn 01/28/2019 6:52:34 AM

I HEREBY CERTIFY THAT THIS PLAN WAS PREPARED BY ME OR UNDER MY DIRECT SUPERVISION AND THAT I AM A DULY LICENSED PROFESSIONAL ENGINEER UNDER THE LAWS OF THE STATE OF MINNESOTA.

PRINT NAME: NICHOLAS DORDA

SIGNATURE: *Nicholas Dorda*

DATE: 2-21-19 LICENSE NO. 49046

DRAWN BY: KT DATE: 10/24/18

DESIGN BY: JCF DATE: 10/24/18

CHECKED BY: NJD DATE: 10/24/18



ANOKA COUNTY
HIGHWAY DEPT.

SP 002-618-032

PLAN PROFILE

STA 117+00.00 TO 128+00.00

Sheet 46 of 126 Sheets

CONSTRUCTION NOTES:

- OVERLAY BITUMINOUS PAVEMENT
 - CONSTRUCT BITUMINOUS PAVEMENT
 - B
 BIT. DRIVEWAY / STREET
 - C
 CONCRETE DRIVEWAY
 - G
 GRAVEL DRIVEWAY
 - H
 8.0' BITUMINOUS SHOULDER
 - I
 1.5' AGGREGATE SHOULDER
 - N
 NEW R/W
 - P
 PERMANENT EASEMENT
 - PROPOSED CULVERT
 - EXISTING CULVERT
- ALL DIMENSIONS ARE TO EDGE OF PAVEMENT UNLESS OTHERWISE NOTED.

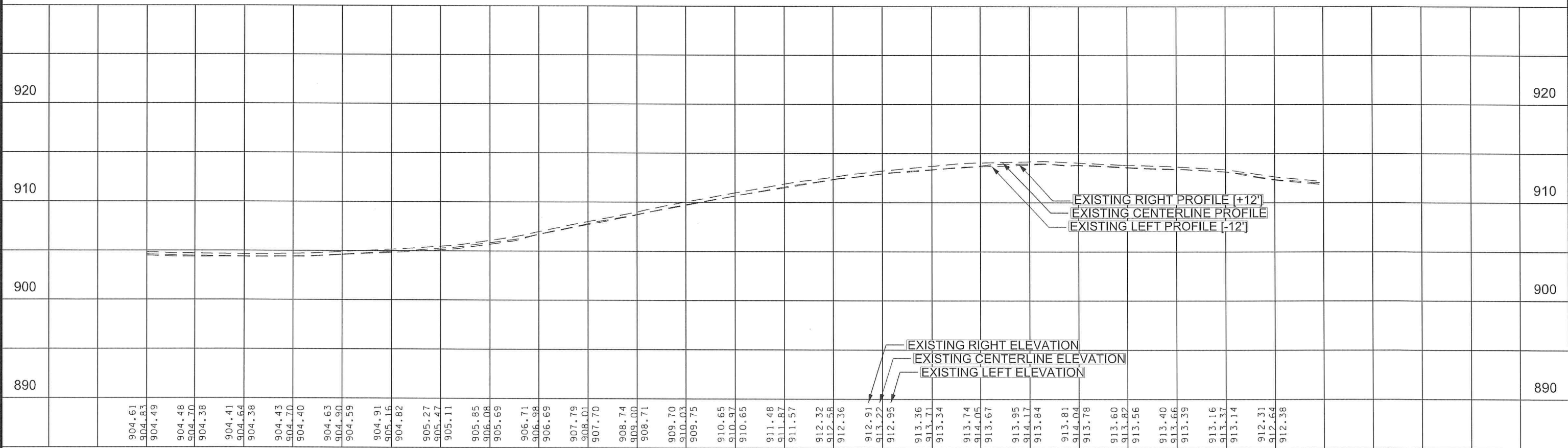
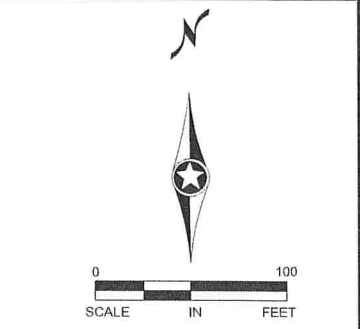
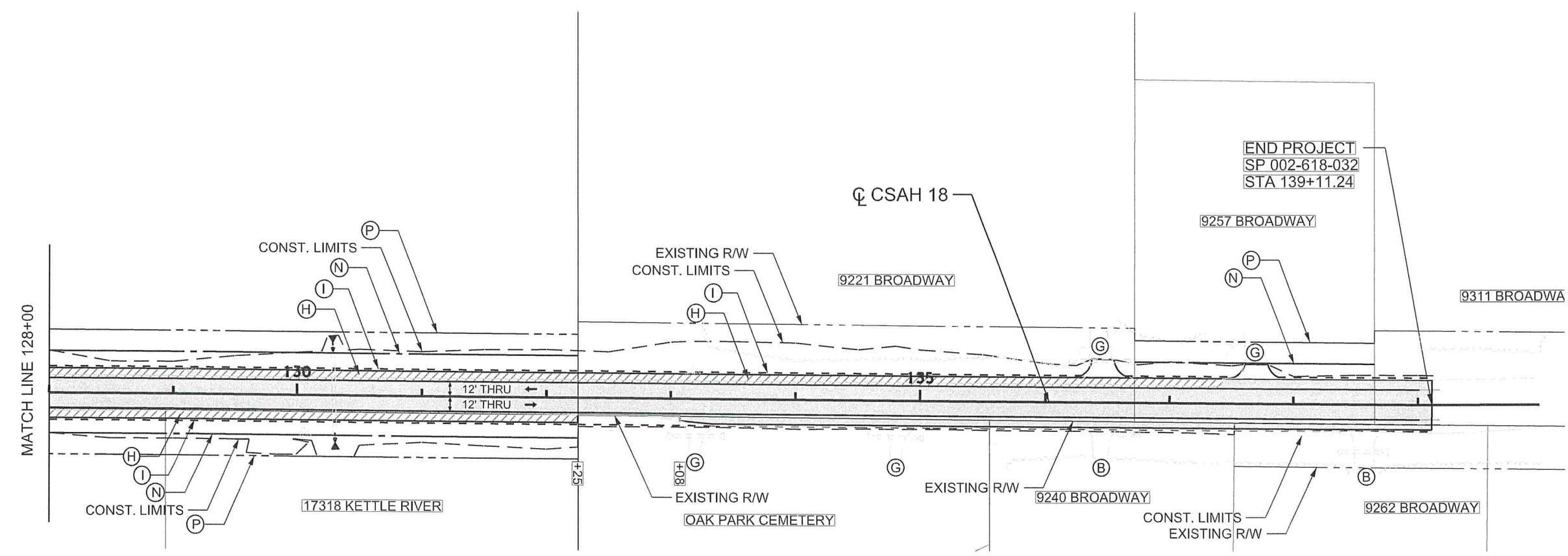

904.61 904.83 904.49 904.48 904.70 904.38	904.41 904.64 904.38	904.43 904.70 904.40	904.63 904.90 904.59	904.91 905.16 904.82	905.27 905.47 905.11	905.85 906.08 905.69	906.71 906.98 906.69	907.79 908.01 907.70	908.74 909.00 908.71	909.70 910.03 909.75	910.65 910.97 910.65	911.48 911.87 911.57	912.32 912.58 912.36	912.91 913.22 912.95	913.36 913.71 913.34	913.74 914.05 913.67	913.95 914.17 913.84	913.81 914.04 913.78	913.60 913.82 913.56	913.40 913.66 913.39	913.16 913.37 913.14	912.31 912.64 912.38	
128+00	129+00	130+00	131+00	132+00	133+00	134+00	135+00	136+00	137+00	138+00	139+00	140+00											

I HEREBY CERTIFY THAT THIS PLAN WAS PREPARED BY ME OR UNDER MY DIRECT SUPERVISION AND THAT I AM A DULY LICENSED PROFESSIONAL ENGINEER UNDER THE LAWS OF THE STATE OF MINNESOTA.

PRINT NAME: NICHOLAS DOBDA
SIGNATURE: *[Signature]*
DATE: 2-21-19 LICENSE NO. 49046

NO	DATE	BY	CKD	APPR	REVISION
	01/29/2019				6:52:35 AM

DRAWN BY: KT DATE: 10/24/18
DESIGN BY: JCF DATE: 10/24/18
CHECKED BY: NJD DATE: 10/24/18

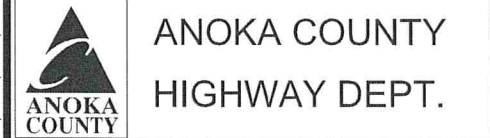

SP 002-618-032

PLAN PROFILE
STA 128+00.00 TO 139+17.62
Sheet 47 of 126 Sheets

PERMANENT PAVEMENT MARKING PLAN
NOTES AND GUIDELINES

GENERAL INFORMATION:

THE ENGINEER'S INVOLVEMENT IN THE APPLICATION OF THE MATERIAL SHALL BE LIMITED TO FIELD CONSULTATION AND INSPECTION. ANOKA COUNTY HIGHWAY DEPARTMENT WILL PLACE NECESSARY "SPOTTING" AT APPROPRIATE POINTS TO PROVIDE HORIZONTAL CONTROL FOR STRIPING AND TO DETERMINE NECESSARY STARTING AND CUTOFF POINTS, LONGITUDINAL JOINTS, PAVEMENT EDGES AND EXISTING MARKINGS MAY SERVE AS HORIZONTAL CONTROL WHEN SO DIRECTED.

EDGE LINES AND LANE LINES ARE TO BE BROKEN ONLY AT INTERSECTIONS WITH PUBLIC ROADS AND AT PRIVATE ENTRANCES IF THEY ARE CONTROLLED BY A YIELD SIGN, STOP SIGN OR TRAFFIC SIGNAL. THE BREAK POINT IS TO BE AT THE START OF THE RADIUS FOR THE INTERSECTION OR AT MARKED STOP LINES OR CROSSWALKS.

A TOLERANCE OF 1/4 INCH UNDER OR 1/4 INCH OVER THE SPECIFIED WIDTH WILL BE ALLOWED FOR STRIPING PROVIDED THE VARIATION IS GRADUAL AND DOES NOT DETRACT FROM THE GENERAL APPEARANCE. BROKEN LINE SEGMENTS MAY VARY UP TO ONE-HALF FOOT FROM THE SPECIFIED LENGTHS PROVIDED THE OVER AND UNDER VARIATIONS ARE REASONABLY COMPENSATORY. ALIGNMENT DEVIATIONS FROM THE CONTROL GUIDE SHALL NOT EXCEED 1 INCH. MATERIAL SHALL NOT BE APPLIED OVER LONGITUDINAL JOINTS, ESTABLISHMENT OF APPLICATION TOLERANCES SHALL NOT RELIEVE THE CONTRACTOR OF THEIR RESPONSIBILITY TO COMPLY AS CLOSELY AS PRACTICABLE WITH THE PLANNED DIMENSIONS.

MULTI COMPONENT (MULTI COMP):

THE ROAD SURFACE SHALL BE CLEANED AT THE DIRECTION OF THE ENGINEER JUST PRIOR TO APPLICATION. PAVEMENT CLEANING SHALL CONSIST OF AT LEAST BRUSHING WITH A ROTARY BROOM (NON-METALLIC) OR AS RECOMMENDED BY THE MATERIAL MANUFACTURER AND ACCEPTABLE TO THE ENGINEER. NEW PORTLAND CEMENT CONCRETE SURFACES SHALL BE SANDBLAST CLEANED TO REMOVE ANY SURFACE TREATMENT AND/OR LAITANCE ON LOW SPEED (SPEED LIMIT 35 MPH OR LESS) URBAN PORTLAND CEMENT CONCRETE ROADWAYS. SANDBLAST CLEANING SHALL BE USED FOR ALL MULTI COMP PAVEMENT MARKINGS.

THE MULTI COMP MARKING APPLICATION SHALL IMMEDIATELY FOLLOW THE PAVEMENT CLEANING. GLASS BEANS SHALL BE APPLIED IMMEDIATELY AFTER APPLICATION OF THE MULTI COMP RESIN LINE TO PROVIDE AN IMMEDIATE NO-TRACK SYSTEM.

A MULTI COMP RESIN LINE SHALL BE APPLIED WITH A MINIMUM THICKNESS OF 20 MILS (WET) AND 4" WIDE. GLASS BEANS SHALL BE APPLIED AT A MINIMUM RATE OF 25LBS POUNDS PER GALLON RATE SUFFICIENT TO ACHIEVE AN ACCEPTABLE NO-TRACK SYSTEM.

OPERATIONS SHALL BE CONDUCTED ONLY WHEN THE ROAD PAVEMENT SURFACE TEMPERATURES ARE 50 DEGREES FAHRENHEIT OR GREATER.

PERMANENT PAVEMENT MARKINGS SHALL NOT BE PLACED OVER TEMPORARY TAPE MARKINGS.

PREFORMED THERMOPLASTIC:

THE PREFORMED THERMOPLASTIC MARKINGS SHALL BE APPLIED IN ACCORDANCE WITH THE MANUFACTURER'S RECOMMENDATIONS ON CLEAN AND DRY SURFACES. SEE SPECIAL PROVISIONS FOR PREFORMED THERMOPLASTIC MARKING SPECIFICATIONS.

PAINT:

AT THE TIME OF APPLYING THE MARKING MATERIAL, THE APPLICATION AREA SHALL BE FREE OF CONTAMINATION. THE CONTRACTOR SHALL CLEAN THE ROADWAY SURFACE PRIOR TO THE LINE APPLICATION IN A MANNER AND TO THE EXTENT REQUIRED BY THE ENGINEER.

GLASS BEADS SHALL BE APPLIED IMMEDIATELY AFTER APPLICATION OF THE PAINT LINE.

EXCEPT WHEN USED AS A TEMPORARY MARKING, PAVEMENT MARKINGS SHALL ONLY BE APPLIED IN SEASONABLE WEATHER WHEN AIR TEMPERATURE IS 50 DEGREES FARHENHEIT OR HIGHER AND SHALL NOT BE APPLIED WHEN THE WIND OR OTHER CONDITIONS CAUSE A FILD OR DUST TO BE DEPOSITED ON THE PAVEMENT SURFACE AFTER CLEANING AND BEFORE THE MARKING MATERIAL CAN BE APPLIED.

THE FILLING OF TANKS, POURING OF MATERIALS OR CLEANING OF EQUIPMENT SHALL NOT BE PERFORMED ON UNPROTECTED PAVEMENT SURFACES UNLESS ADEQUATE PROVISIONS ARE MADE TO PREVENT SPILLAGE OF MATERIAL.

M PAVEMENT MARKING TABULATION		
ITEM	UNIT	TOTAL QUANTITY
4" SOLID LINE WHITE - MULTI COMP	LIN FT	28740
8" DOTTED LINE WHITE - MULTI COMP	LIN FT	99
4" BROKEN LINE YELLOW - MULTI COMP	LIN FT	2000
4" SOLID LINE YELLOW - MULTI COMP	LIN FT	1800
4" SOLID DOUBLE LINE YELLOW - MULTI COMP	LIN FT	3130

1 - 3' Skip 12' Gap
2 - 10' Skip 40' Gap

SYMBOLS & MATERIALS LEGEND

- CROSSWALK BLOCK WHITE-POLY PREFORM
- ↩ PAVEMENT MESSAGE (LEFT ARROW) POLY PREFORM

STRIPING KEY

- CIRCLE - MULTI COMP
- SQUARE - POLY PREFORM THERMOPLASTIC
- △ TRIANGLE - PAINT
- ⬠ PENTAGON - REMOVABLE PREFORMED PLASTIC MARKING

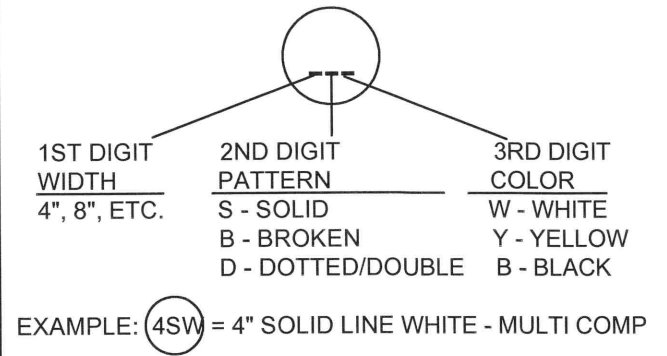

1	04/01/19	TV	ST	JR	UPDATES TO PERMANENT SIGNING AND STRIPING PLAN SHEETS
NO	DATE	BY	CKD	APPR	REVISION
NAME: P:\002-618-032\Base\Traffic\Perm pvmt mrkg guide notes_guidelines.dwg					

I HEREBY CERTIFY THAT THIS PLAN WAS PREPARED BY ME OR UNDER MY DIRECT SUPERVISION AND THAT I AM A DULY LICENSED PROFESSIONAL ENGINEER UNDER THE LAWS OF THE STATE OF MINNESOTA.

PRINT NAME: DOUGLAS W. FISCHER, P.E.
SIGNATURE: *[Signature]*
DATE: 4/2/19 REG. NO. 20235

DRAWN BY: TMV DATE: 02/02/00
DESIGN BY: DATE:
CHECKED BY: DATE:

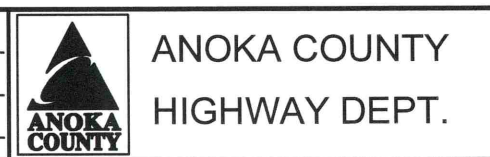

STATE PROJECT NO. 002-618-032
STATE AID PROJECT NO. _____
CITY PROJECT NO. _____
COUNTY PROJECT NO. _____

PERMANENT MARKING TABULATION
Sheet 48 of 126 Sheets

NOTES:

- 1 FURNISH AND INSTALL
- 3 SALVAGE FOR RE-USE ON THIS PROJECT
- 4 INSTALL SALVAGED SIGN
- 5 REMOVE SIGN
- 8 INSTALL SALVAGED SIGN TYPE SPECIAL
- 9 RETAIN IN-PLACE SIGN

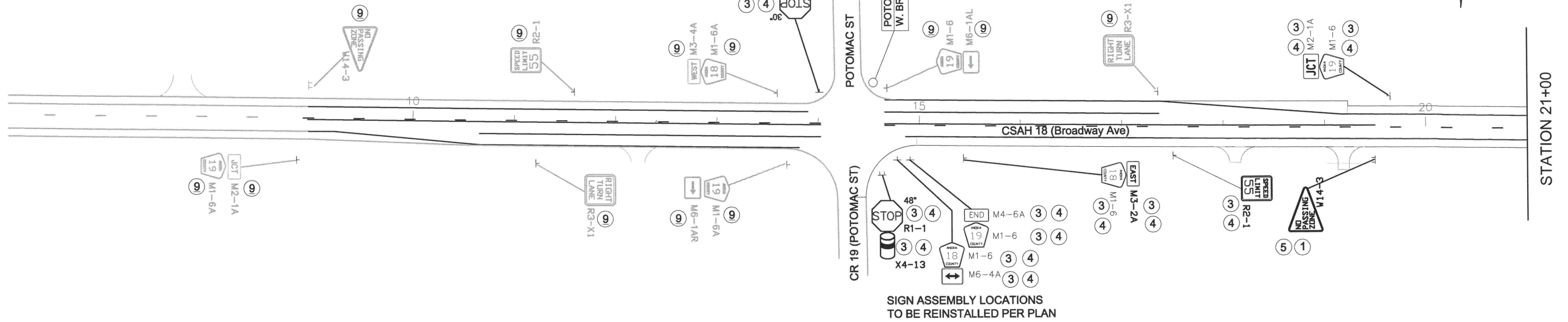

SIGN ASSEMBLY LOCATIONS
TO BE REINSTALLED PER PLAN

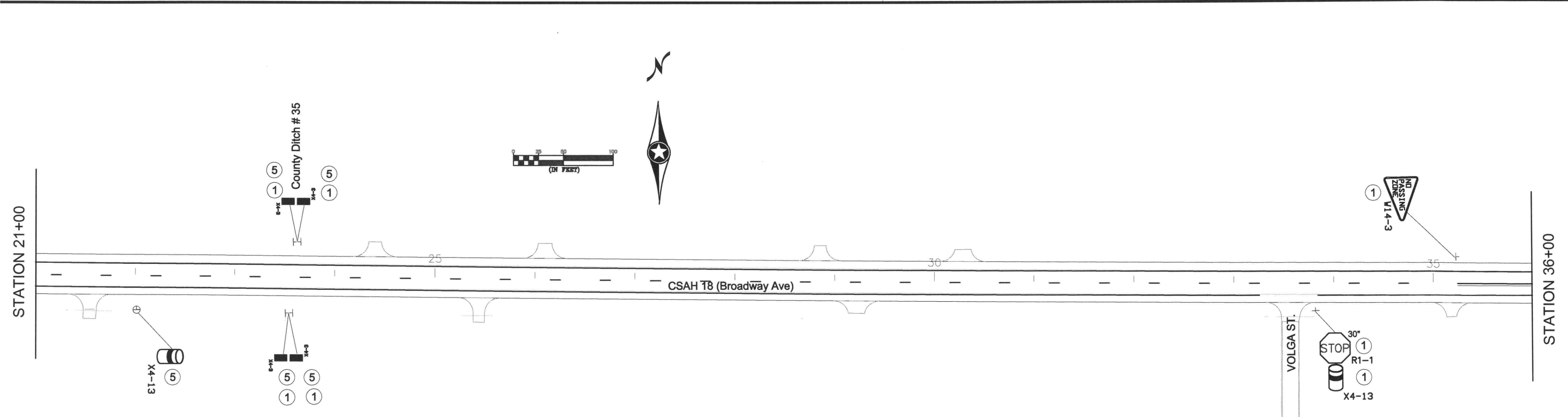

NO	DATE	BY	CKD	APPR	REVISION
1	04/01/19	TV	ST	JR	UPDATES TO PERMANENT SIGNING AND STRIPING PLAN SHEETS

I HEREBY CERTIFY THAT THIS PLAN WAS PREPARED BY ME OR UNDER MY DIRECT SUPERVISION AND THAT I AM A DULY LICENSED PROFESSIONAL ENGINEER UNDER THE LAWS OF THE STATE OF MINNESOTA.
PRINT NAME: DOUGLAS W. FISCHER
SIGNATURE: *[Signature]*
DATE: 4/10/19 LICENSE NO. 20235

DRAWN BY: TV DATE: 09/20/18
DESIGN BY: _____ DATE: _____
CHECKED BY: _____ DATE: _____



ANOKA COUNTY
HIGHWAY DEPT.

STATE PROJECT NO. 002-618-032
STATE AID PROJECT NO. _____
CITY PROJECT NO. _____
COUNTY PROJECT NO. _____

SIGNING PLAN
Sheet 49 of 126 Sheets

NOTES:

- ① FURNISH AND INSTALL
- ③ SALVAGE FOR RE-USE ON THIS PROJECT
- ④ INSTALL SALVAGED SIGN
- ⑤ REMOVE SIGN
- ⑧ INSTALL SALVAGED SIGN TYPE SPECIAL
- ⑨ RETAIN IN-PLACE SIGN

STATION 36+00

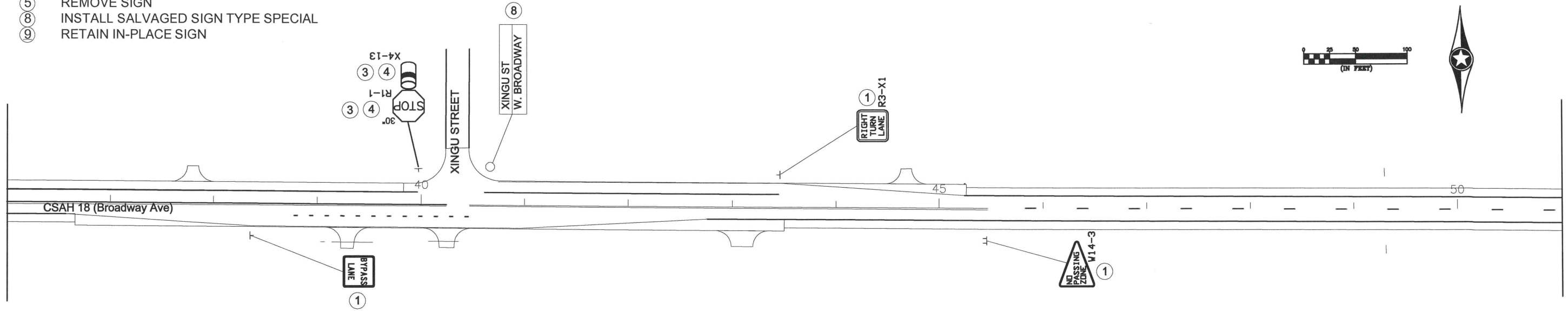

STATION 51+00

STATION 51+00

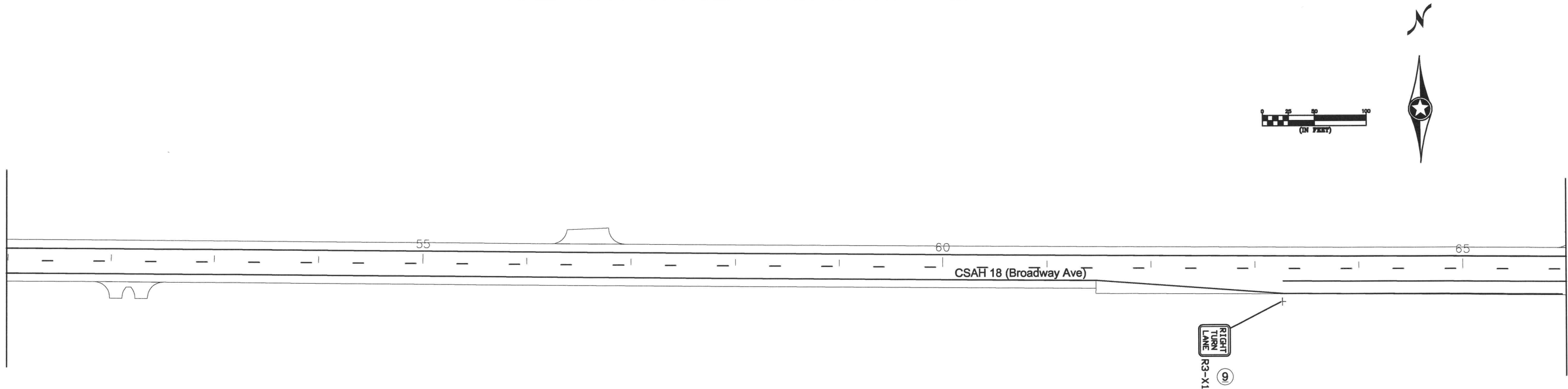

STATION 66+00

1	04/01/19	TV	ST	JR	UPDATES TO PERMANENT SIGNING AND STRIPING PLAN SHEETS
NO	DATE	BY	CKD	APPR	REVISION
NAME: P/02-618-032/Base/Traffic/Perm Striping					

I HEREBY CERTIFY THAT THIS PLAN WAS PREPARED BY ME OR UNDER MY DIRECT SUPERVISION AND THAT I AM A DULY LICENSED PROFESSIONAL ENGINEER UNDER THE LAWS OF THE STATE OF MINNESOTA.
 PRINT NAME: DOUGLAS W. FISCHER
 SIGNATURE: *[Signature]*
 DATE: 4/10/19 LICENSE NO. 20235

DRAWN BY: TV DATE: 09/20/18
 DESIGN BY: DATE: _____
 CHECKED BY: DATE: _____



ANOKA COUNTY
 HIGHWAY DEPT.

STATE PROJECT NO. 002-618-032
 STATE AID PROJECT NO. _____
 CITY PROJECT NO. _____
 COUNTY PROJECT NO. _____

SIGNING PLAN
 Sheet 50 of 126 Sheets

- NOTES:
- ① FURNISH AND INSTALL
 - ③ SALVAGE FOR RE-USE ON THIS PROJECT
 - ④ INSTALL SALVAGED SIGN
 - ⑤ REMOVE SIGN
 - ⑧ INSTALL SALVAGED SIGN TYPE SPECIAL
 - ⑨ RETAIN IN-PLACE SIGN

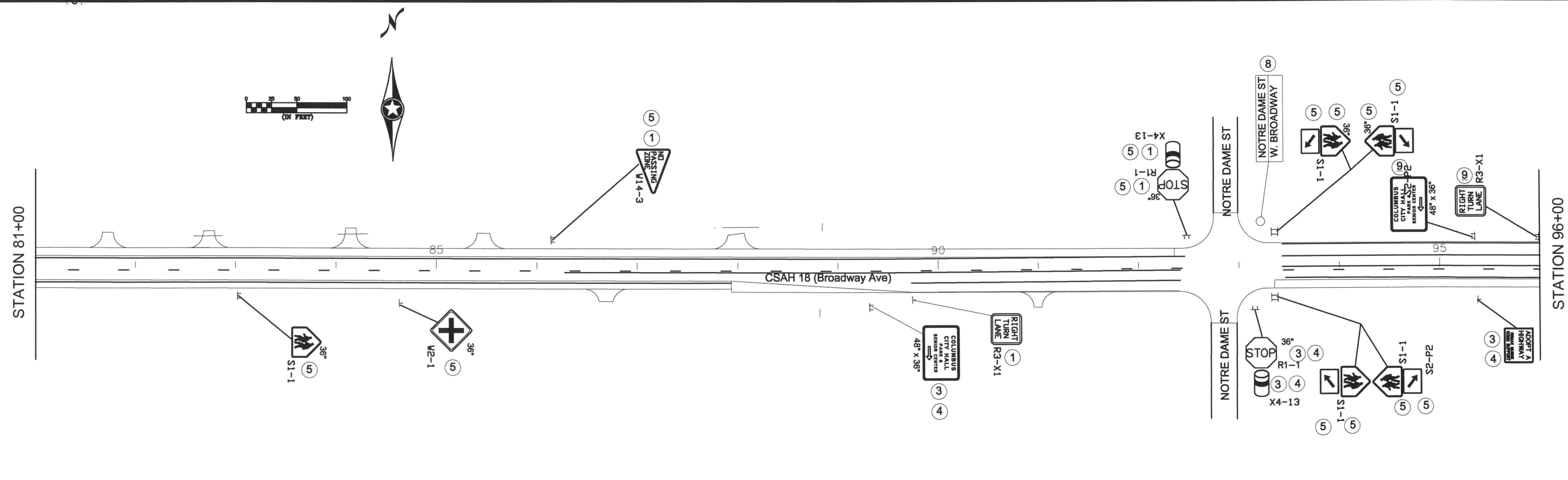
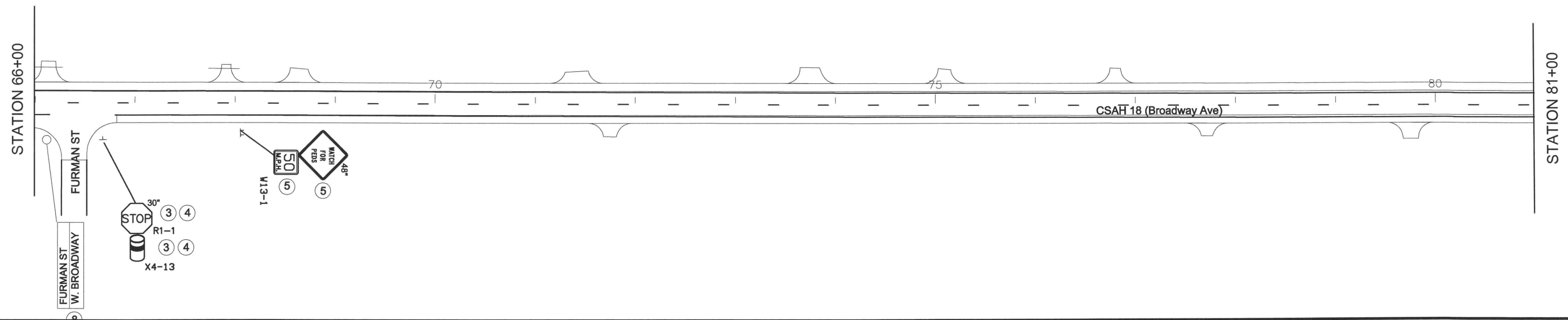
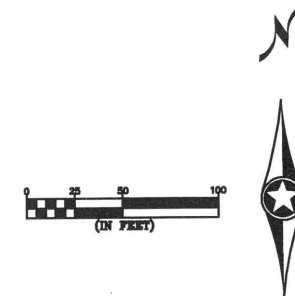

1	04/01/19	TV	ST	JR	UPDATES TO PERMANENT SIGNING AND STRIPING PLAN SHEETS
NO	DATE	BY	CKD	APPR	REVISION
NAME: Pv/02-618-032/Base/Traffic/Perm Striping					

I HEREBY CERTIFY THAT THIS PLAN WAS PREPARED BY ME OR UNDER MY DIRECT SUPERVISION AND THAT I AM A DULY LICENSED PROFESSIONAL ENGINEER UNDER THE LAWS OF THE STATE OF MINNESOTA.
 PRINT NAME: DOUGLAS W. FISCHER
 SIGNATURE: *[Signature]*
 DATE: 9/20/19 LICENSE NO. 20235

DRAWN BY: TV DATE: 09/20/18
 DESIGN BY: DATE: _____
 CHECKED BY: DATE: _____

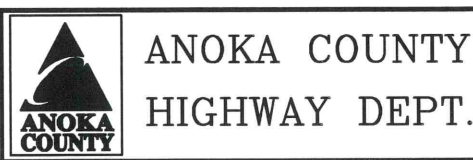

STATE PROJECT NO. 002-618-032
 STATE AID PROJECT NO. _____
 CITY PROJECT NO. _____
 COUNTY PROJECT NO. _____

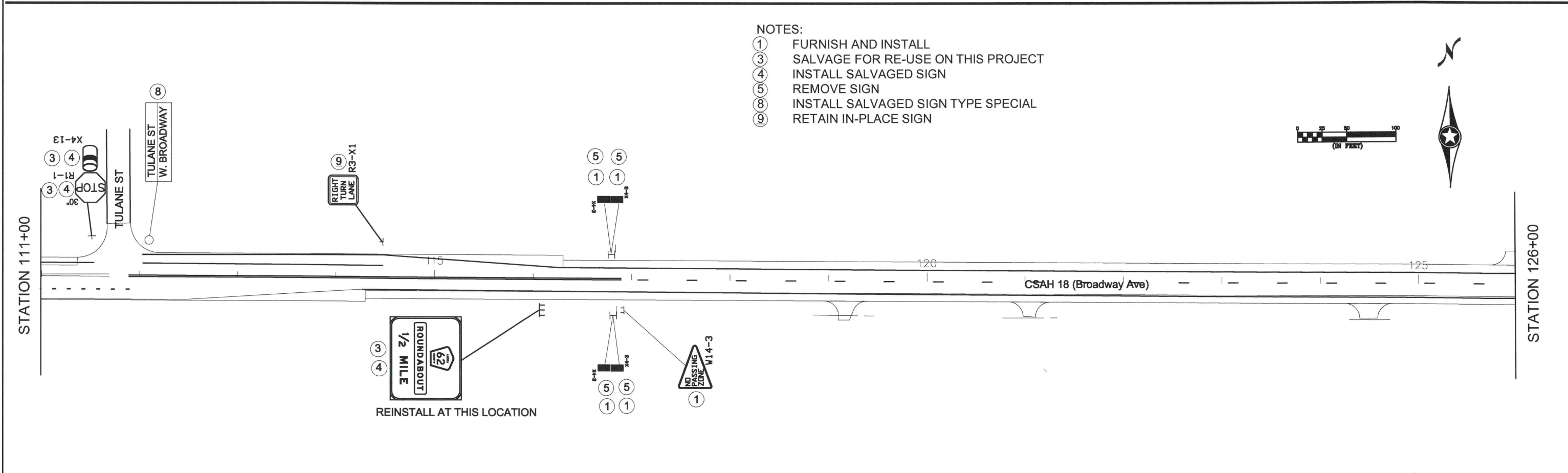
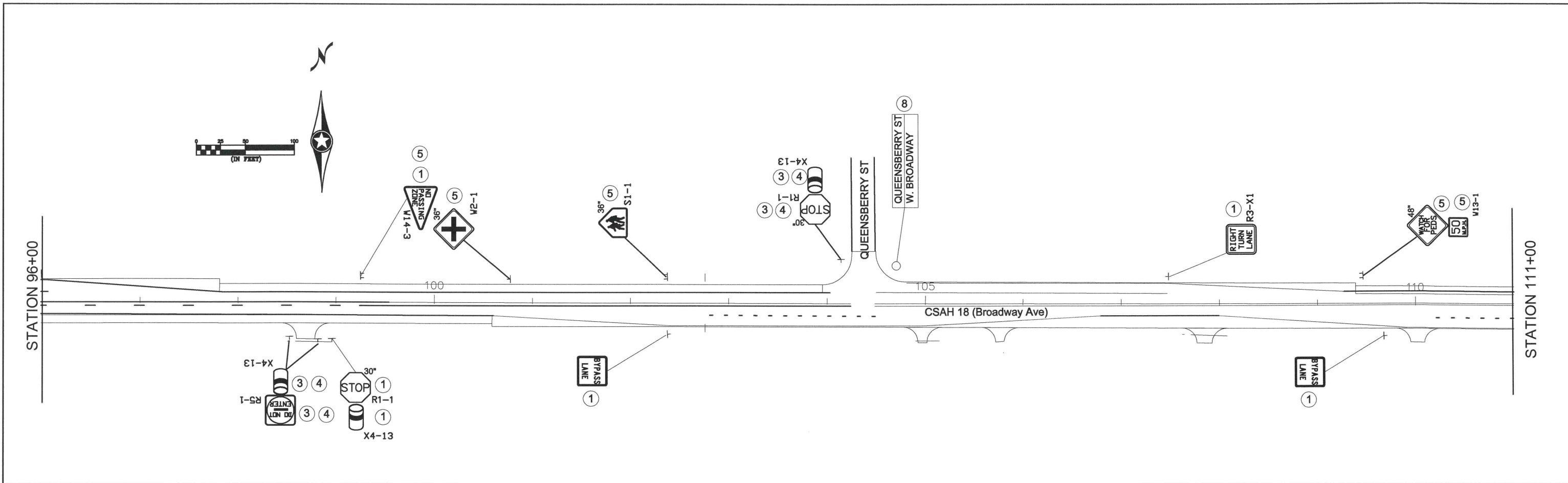

- NOTES:
- ① FURNISH AND INSTALL
 - ③ SALVAGE FOR RE-USE ON THIS PROJECT
 - ④ INSTALL SALVAGED SIGN
 - ⑤ REMOVE SIGN
 - ⑧ INSTALL SALVAGED SIGN TYPE SPECIAL
 - ⑨ RETAIN IN-PLACE SIGN

1	04/01/19	TV	ST	JR	UPDATES TO PERMANENT SIGNING AND STRIPING PLAN SHEETS
NO	DATE	BY	CKD	APPR	REVISION
NAME: P/02-618-032/Base/Traffic/Perm Striping					

I HEREBY CERTIFY THAT THIS PLAN WAS PREPARED BY ME OR UNDER MY DIRECT SUPERVISION AND THAT I AM A DULY LICENSED PROFESSIONAL ENGINEER UNDER THE LAWS OF THE STATE OF MINNESOTA.

PRINT NAME: DOUGLAS W. FISCHER

SIGNATURE: *[Signature]*

DATE: 4/10/19 LICENSE NO. 20235

DRAWN BY: TV DATE: 09/20/18

DESIGN BY: DATE:

CHECKED BY: DATE:

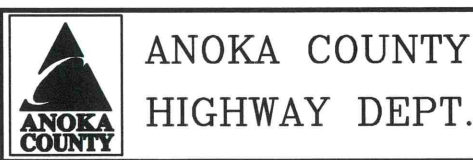

STATE PROJECT NO. 002-618-032

STATE AID PROJECT NO. _____

CITY PROJECT NO. _____

COUNTY PROJECT NO. _____



- NOTES:
- ① FURNISH AND INSTALL
 - ③ SALVAGE FOR RE-USE ON THIS PROJECT
 - ④ INSTALL SALVAGED SIGN
 - ⑤ REMOVE SIGN
 - ⑧ INSTALL SALVAGED SIGN TYPE SPECIAL
 - ⑨ RETAIN IN-PLACE SIGN

STATION 126+00

STATION 141+00

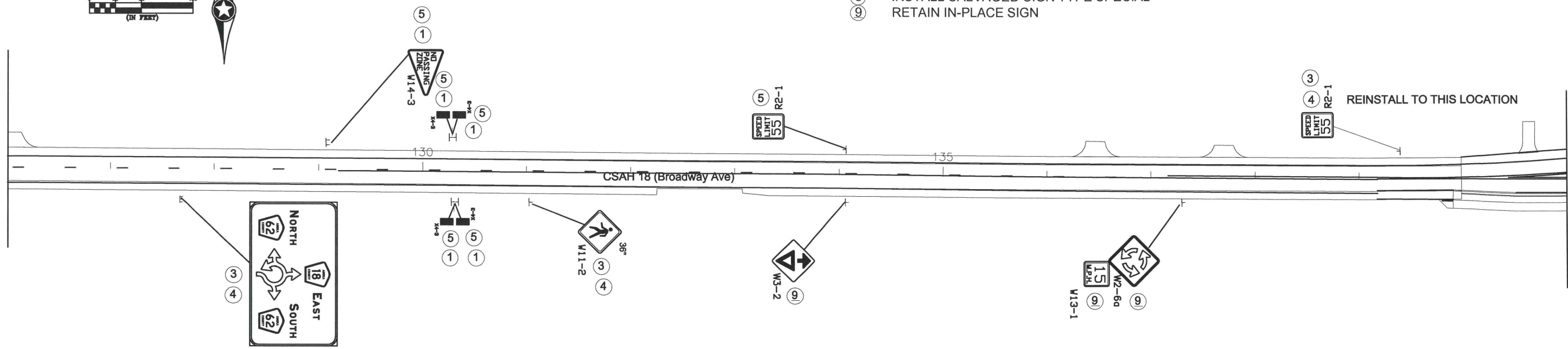

1	04/01/19	TV	ST	JR	UPDATES TO PERMANENT SIGNING AND STRIPING PLAN SHEETS
NO	DATE	BY	CKD	APPR	REVISION
NAME: P1/02-618-032/Base/Traffic/Perm Striping					

I HEREBY CERTIFY THAT THIS PLAN WAS PREPARED BY ME OR UNDER MY DIRECT SUPERVISION AND THAT I AM A DULY LICENSED PROFESSIONAL ENGINEER UNDER THE LAWS OF THE STATE OF MINNESOTA.
 PRINT NAME: DOUGLAS W. FISCHER
 SIGNATURE: *[Signature]*
 DATE: 4/10/19 LICENSE NO. 20235

DRAWN BY: TV DATE: 09/20/18
 DESIGN BY: DATE: _____
 CHECKED BY: DATE: _____

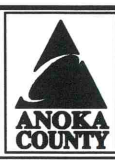





ANOKA COUNTY
 HIGHWAY DEPT.

STATE PROJECT NO. 002-618-032
 STATE AID PROJECT NO. _____
 CITY PROJECT NO. _____
 COUNTY PROJECT NO. _____

SIGNING PLAN
 Sheet 53 of 126 Sheets

STRIPING KEY

-  CIRCLE - MULTI COMP
-  SQUARE - POLY PREFORM
-  TRIANGLE - PAINT
-  PENTAGON - REMOVABLE PREFORMED PLASTIC MARKING

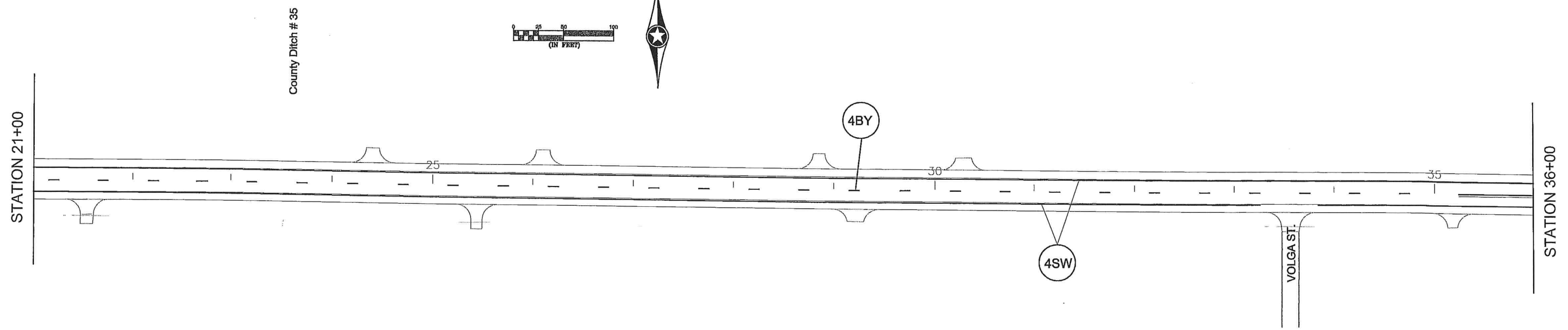
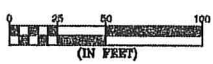
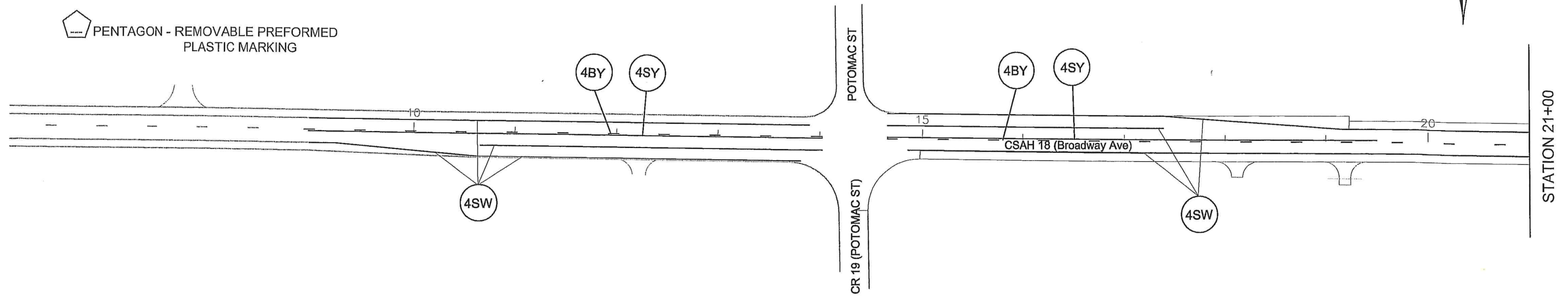
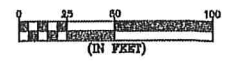

NO	DATE	BY	CHKD	APPR	REVISION
NAME: P/02-618-032/Base/Traffic/Perm Striping					

I HEREBY CERTIFY THAT THIS PLAN WAS PREPARED BY ME OR UNDER MY DIRECT SUPERVISION AND THAT I AM A DULY LICENSED PROFESSIONAL ENGINEER UNDER THE LAWS OF THE STATE OF MINNESOTA.
 PRINT NAME: DOUGLAS W. FISCHER
 SIGNATURE: *[Signature]*
 DATE: 2/25/19 LICENSE NO. 20235

DRAWN BY: TV DATE: 09/20/18
 DESIGN BY: DATE:
 CHECKED BY: DATE:







ANOKA COUNTY
 HIGHWAY DEPT.

STATE PROJECT NO. 002-618-032
 STATE AID PROJECT NO.
 CITY PROJECT NO.
 COUNTY PROJECT NO.

PERMANENT STRIPING PLAN
 Sheet 54 of 126 Sheets

STRIPING KEY

-  CIRCLE - MULTI COMP
-  SQUARE - POLY PREFORM
-  TRIANGLE - PAINT
-  PENTAGON - REMOVABLE PREFORMED PLASTIC MARKING

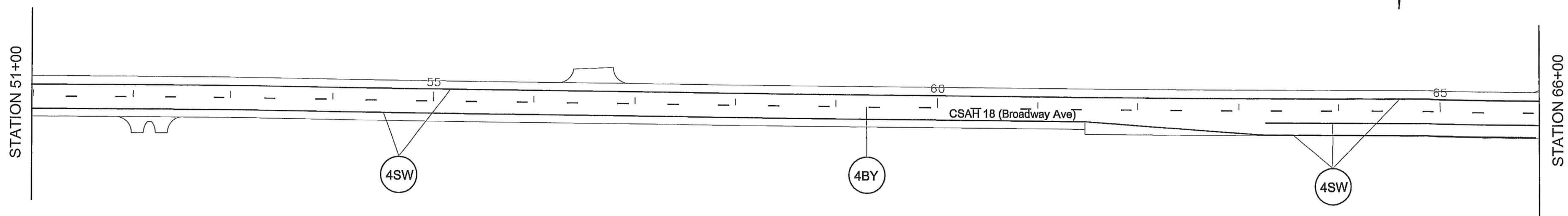
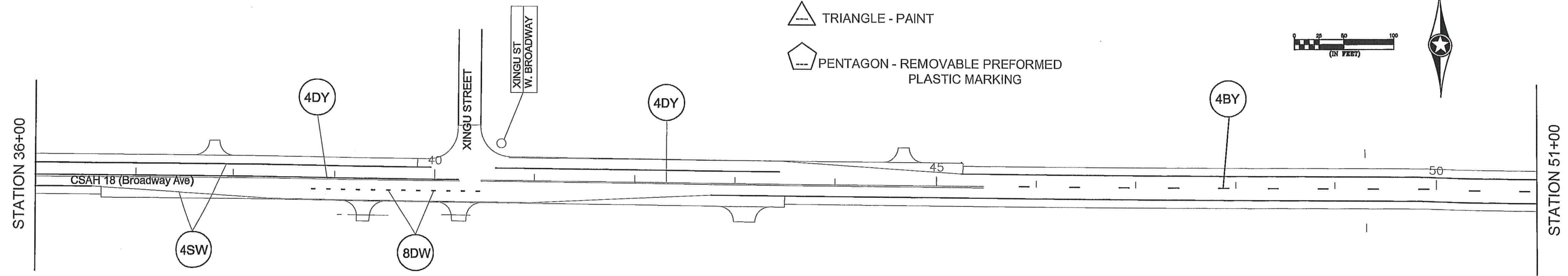

NO	DATE	BY	CHKD	APPR	REVISION
NAME: P/02-618-032/Base/Traffic/Perm Striping					

I HEREBY CERTIFY THAT THIS PLAN WAS PREPARED BY ME OR UNDER MY DIRECT SUPERVISION AND THAT I AM A DULY LICENSED PROFESSIONAL ENGINEER UNDER THE LAWS OF THE STATE OF MINNESOTA.

PRINT NAME: DOUGLAS W. FISCHER

SIGNATURE: 

DATE: 2/25/19 LICENSE NO. 20235

DRAWN BY: TV DATE: 09/20/18

DESIGN BY: _____ DATE: _____

CHECKED BY: _____ DATE: _____



ANOKA COUNTY
HIGHWAY DEPT.





STATE PROJECT NO. 002-618-032

STATE AID PROJECT NO. _____

CITY PROJECT NO. _____

COUNTY PROJECT NO. _____

STRIPING KEY

-  CIRCLE - MULTI COMP
-  SQUARE - POLY PREFORM
-  TRIANGLE - PAINT
-  PENTAGON - REMOVABLE PREFORMED PLASTIC MARKING



STATION 66+00

STATION 81+00

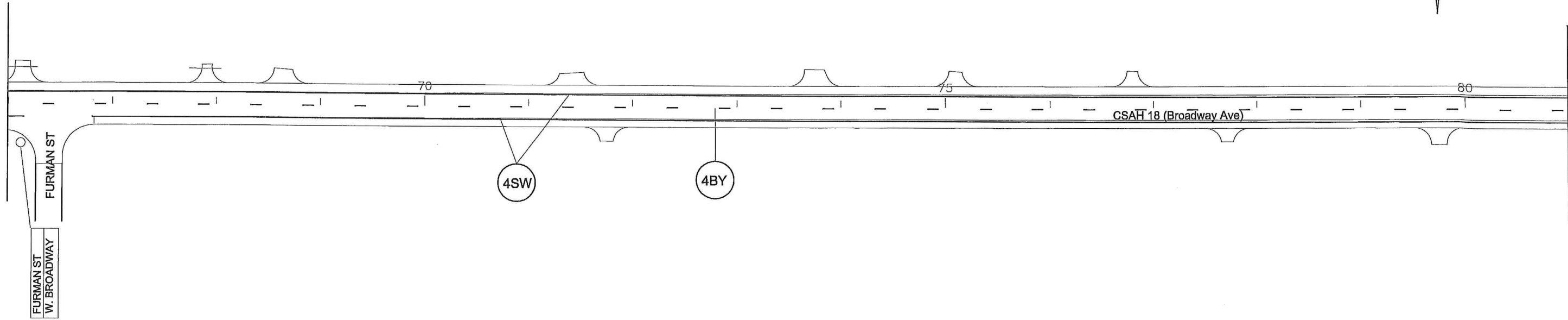

STATION 81+00

STATION 96+00

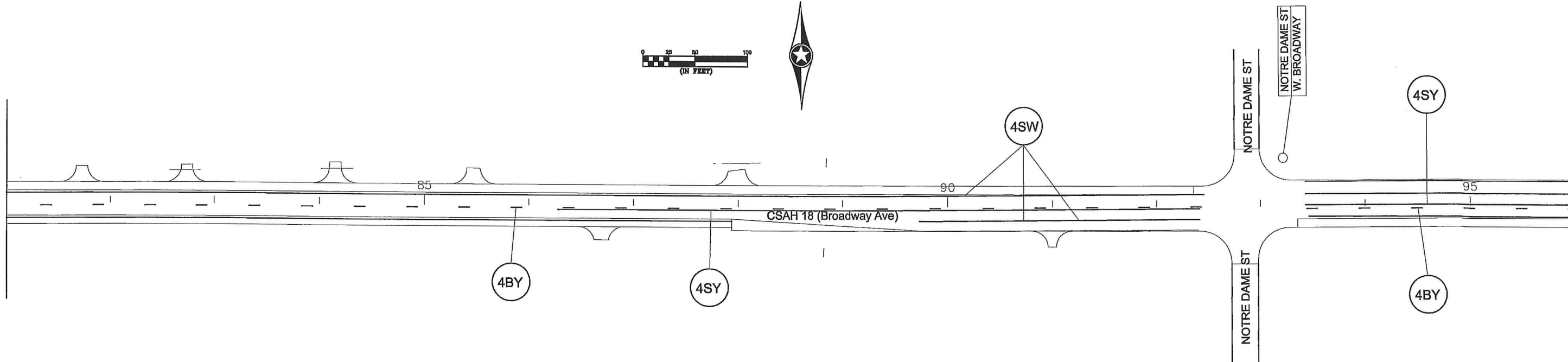

NO	DATE	BY	CKD	APPR	REVISION

I HEREBY CERTIFY THAT THIS PLAN WAS PREPARED BY ME OR UNDER MY DIRECT SUPERVISION AND THAT I AM A DULY LICENSED PROFESSIONAL ENGINEER UNDER THE LAWS OF THE STATE OF MINNESOTA.

PRINT NAME: DOUGLAS W. FISCHER
 SIGNATURE: *[Signature]*
 DATE: 2/25/19 LICENSE NO. 20235

DRAWN BY: TV DATE: 09/20/18
 DESIGN BY: DATE:
 CHECKED BY: DATE:

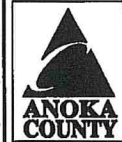





ANOKA COUNTY
 HIGHWAY DEPT.

STATE PROJECT NO. 002-618-032
 STATE AID PROJECT NO.
 CITY PROJECT NO.
 COUNTY PROJECT NO.

PERMANENT STRIPING PLAN
 Sheet 56 of 126 Sheets

STRIPING KEY

-  CIRCLE - MULTI COMP
-  SQUARE - POLY PREFORM
-  TRIANGLE - PAINT
-  PENTAGON - REMOVABLE PREFORMED PLASTIC MARKING

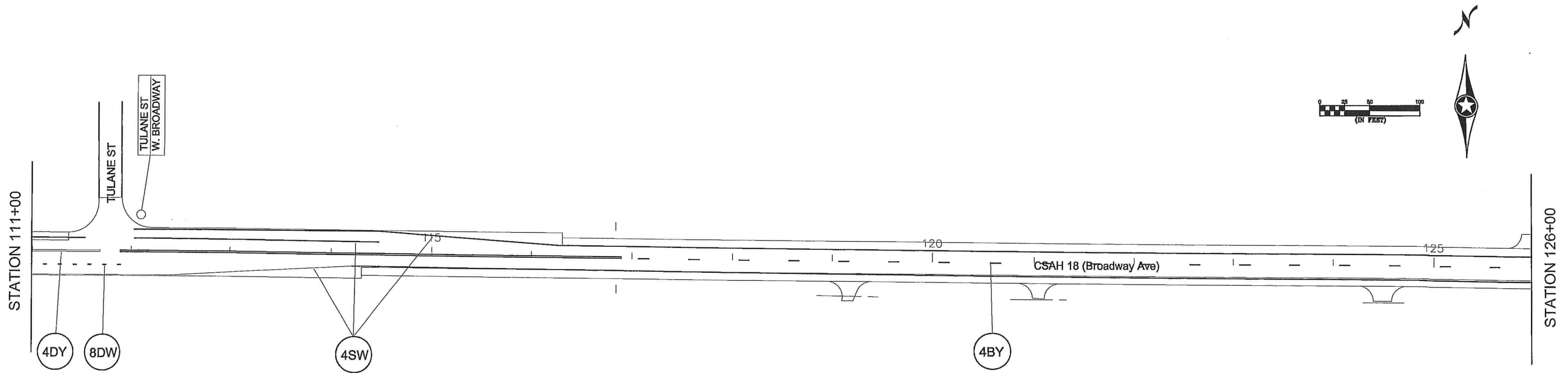
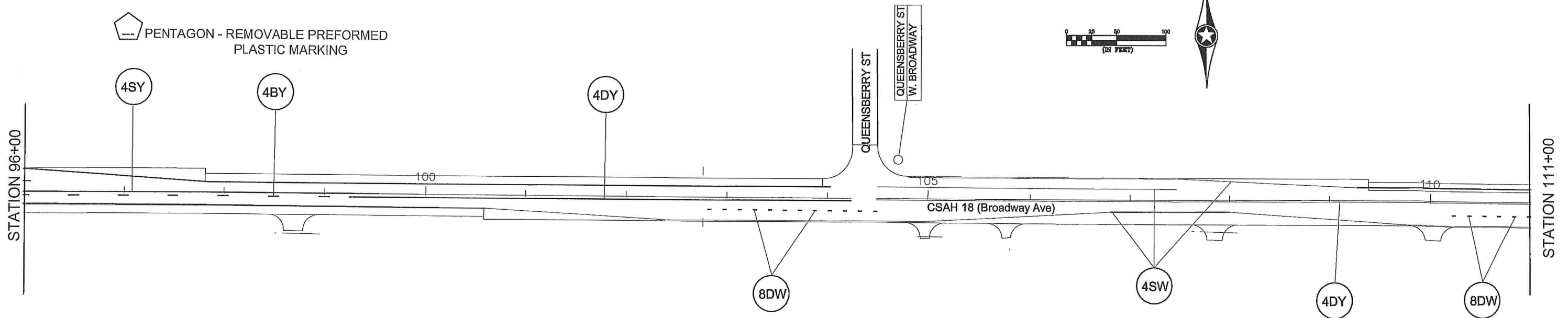

NO	DATE	BY	CKD	APPR	REVISION
NAME: P/02-618-032/Base/Traffic/Perm Striping					

I HEREBY CERTIFY THAT THIS PLAN WAS PREPARED BY ME OR UNDER MY DIRECT SUPERVISION AND THAT I AM A DULY LICENSED PROFESSIONAL ENGINEER UNDER THE LAWS OF THE STATE OF MINNESOTA.
 PRINT NAME: DOUGLAS W. FISCHER
 SIGNATURE: *[Signature]*
 DATE: 2/25/19 LICENSE NO. 20235

DRAWN BY: TV DATE: 09/20/18
 DESIGN BY: DATE:
 CHECKED BY: DATE:



**ANOKA COUNTY
 HIGHWAY DEPT.**

STATE PROJECT NO. 002-618-032
 STATE AID PROJECT NO.
 CITY PROJECT NO.
 COUNTY PROJECT NO.

PERMANENT STRIPING PLAN
 Sheet 57 of 126 Sheets

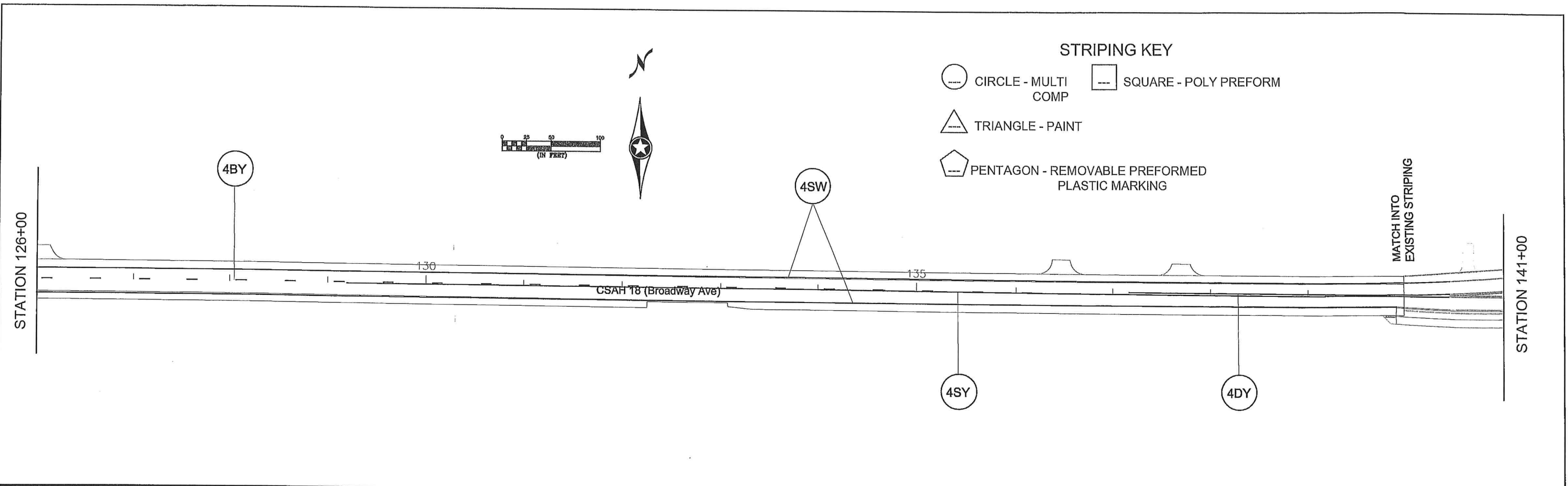

STRIPING KEY

- CIRCLE - MULTI COMP
- SQUARE - POLY PREFORM
- TRIANGLE - PAINT
- PENTAGON - REMOVABLE PREFORMED PLASTIC MARKING

NO	DATE	BY	CKD	APPR	REVISION

I HEREBY CERTIFY THAT THIS PLAN WAS PREPARED BY ME OR UNDER MY DIRECT SUPERVISION AND THAT I AM A DULY LICENSED PROFESSIONAL ENGINEER UNDER THE LAWS OF THE STATE OF MINNESOTA.
 PRINT NAME: DOUGLAS W. FISCHER
 SIGNATURE: *[Signature]*
 DATE: 2/25/19 LICENSE NO. 20235

DRAWN BY TV DATE 09/20/18
 DESIGN BY DATE
 CHECKED BY DATE



ANOKA COUNTY
 HIGHWAY DEPT.

STATE PROJECT NO. 002-618-032
 STATE AID PROJECT NO.
 CITY PROJECT NO.
 COUNTY PROJECT NO.

PERMANENT STRIPING PLAN
 Sheet 58 of 126 Sheets

N REMOVE & SALVAGE SIGN PANELS										
STATION	ADDRESS/ DESCRIPTION (NOTES)	REMOVE SIGN TYPE C	SALVAGE SIGN TYPE C	REMOVE SIGN TYPE D	SALVAGE SIGN TYPE SPECIAL	INSTALL SIGN TYPE C	INSTALL SIGN TYPE D	INSTALL SIGN TYPE SPECIAL	SIGN NUMBER	SIGN LEGEND
		EACH	EACH	EACH	EACH	EACH	EACH	EACH		
14+10	Lt		1			1			R1-1 30" Stop	
14+60	Rt		1			1			X4-13 Delineator	
14+70	Rt		1			1			R1-1 48" Stop	
14+80	Rt		1			1			X4-13 Delineator	
15+50	Rt		1			1			M1-6A 18 Rte Mkr	
19+70	Rt	1							M6-4A Dble Arrow	
19+70	Rt	1							M4-6A END	
22+00	Rt	1							M1-6A 19 Rte Mkr	
22+80	Lt		1			1			M3-2A EAST	
23+50	Rt	1							M1-6A 18 Rte Mkr	
23+65	Lt	1							W14-3 No Passing Zone	
40+20	Lt		1			1			R2-1 55 MPH	
40+60	Lt				1			1	X4-13 Delineator	
66+10	Rt				1			1	X4-13 Delineator	
66+60	Rt		1			1			M2-1A JCT	
68+05	Rt	1							M1-6A 19 Rte Mkr	
83+00	Rt	1							X4-3 Culvert Mkr	
84+70	Rt	1							X4-3 Culvert Mkr	
86+25	Lt	1							X4-3 Culvert Mkr	
91+20	Rt			1				1	R1-1 30" Stop	
92+60	Lt	1							X4-13 Delineator	
93+10	Rt		1			1			R1-1 36" Stop	
93+15	Lt		1			1			X4-13 Delineator	
93+35	Rt	1							Street Sign	
93+35	Lt	1							R1-1 30" Stop	
95+40	Rt		1			1			S1-1 School Xing	
98+50	Rt		1			1			W16-7mpL Down Rt Arrow	
98+85	Rt		1			1			S1-1 School Xing	
99+50	Lt	1							W16-7mpL Down Left Arrow	
100+80	Lt	1							S1-1 School Xing	
102+45	Lt	1							W16-7mpL Down Rt Arrow	
104+20	Lt		1			1			S1-1 School Xing	
104+70	Lt				1			1	W16-7mpL Down Left Arrow	
109+40	Lt	1							S1-1 School Xing	
111+60	Lt		1			1			W16-7mpL Down Left Arrow	
112+10	Lt				1			1	I-X1 Adopt A Highway	
116+80	Rt	1							R5-1 Do Not Enter	
116+70	Lt	1							X4-13 Delineator	
118+00	Rt			1				1	R5-1 Do Not Enter	
127+70	Rt			1				1	X4-13 Delineator	
129+15	Lt	1							W14-3 No Passing Zone	
130+30	Lt	1							X4-3 Culvert Mkr	
130+30	Rt	1							X4-3 Culvert Mkr	
130+00	Rt		1			1			X4-3 Culvert Mkr	
134+10	Lt	1							W11-2 Ped Xing	
133+20	Lt		1			1			R2-1 55 MPH	
PROJECT TOTAL		21	18	3	4	18	3	4		

N FURNISH & INSTALL SIGN PANELS TYPE C							
M.U.T.C.D. CODE	SIZE	INSERT	QUANTITY	PANEL AREA	TOTAL AREA	MOUNTING POST PER INSTALLATION	MOUNTING HEIGHT To pavement edge
				SQ. FT.	SQ. FT.		
R1-1	30" x 30"	STOP	2	6.25	12.50	1	7.0'
	36" x 36"		1	9.00	9.00	2	7.0'
R3-X1	30" x 30"	RIGHT TURN LANE	3	6.25	18.75	1	7.0'
R4-X8	30" x 30"	BYPASS LANE	3	6.25	18.75	1	7.0'
W14-3	48" x 48" x 36"	NO PASSING ZONE	7	5.56	38.92	2	7.0'
TOTAL TYPE C SIGN SQ FT				97.92			

N FURNISH & INSTALL SIGN PANELS MARKERS							
M.U.T.C.D. CODE	SIZE	INSERT	QUANTITY	PANEL AREA	TOTAL AREA	MOUNTING POST PER INSTALLATION	MOUNTING HEIGHT To pavement edge
				SQ. FT.	SQ. FT.		
X4-3	6" x 12"		12	0.50	6.00	1	4.0'
X4-13	4" x 15"		3	0.42	1.26	TO BE ATTACHED TO STOP SIGN	
TOTAL MARKER SIGNS SQ FT				7.26			
PROJECT TOTAL SQ FT				105.28			

N REINSTALL SALVAGED SIGN ASSEMBLIES TYPE D				
SIZE	INSERT	QUANTITY	MOUNTING POST PER INSTALLATION	MOUNTING HEIGHT To pavement edge
48" x 36"	COLUMBUS CITY HALL PARK & SENIOR CENTER	1	2	7.0'
84" x 72"	ROUNDABOUT 1/2 MILE	1	2	7.0'
138" x 84"	NORTH SOUTH EAST WEST	1	3	7.0'
TOTAL TYPE D SIGN ASSEMBLIES		3		
PROJECT TOTAL SALVAGED ASSEMBLIES		23		

N REINSTALL SALVAGED SIGN ASSEMBLIES TYPE C				
SIZE	INSERT	QUANTITY	MOUNTING POST PER INSTALLATION	MOUNTING HEIGHT To pavement edge
			1	2
30" x 30"	STOP	6	1	7.0'
36" x 36"		1	2	7.0'
48" x 48"		1	2	7.0'
4" x 15"		8		
24" x 30"	SPEED LIMIT 55	1	1	7.0'
30" x 30"	DO NOT ENTER	2	1	7.0'
4" x 15"		2		
30" x 30"		1	1	7.0'
48" x 36"	NO PASSING ZONE	3	2	7.0'
30" x 24"	ADOPT A HIGHWAY	1	1	7.0'
24" x 12"	EAST	1	1	7.0'
24" x 24"	18	2		
21" x 15"		1		
24" x 12"	END	1	1	7.0'
21" x 15"	JCT	1		
24" x 24"	19	2		
TOTAL TYPE C SIGN ASSEMBLIES			20	

- NOTES:
- ALL TRAFFIC CONTROL DEVICES SHALL CONFORM AND BE PLACED IN ACCORDANCE TO THE "MINNESOTA MANUAL ON UNIFORM TRAFFIC CONTROL DEVICES" (MN MUTCD), INCLUDING PART VI, "FIELD MANUAL" FOR TEMPORARY TRAFFIC CONTROL ZONE LAYOUTS".
 - LOCATIONS OF ALL PERMANENT STRIPING AND PAVEMENT MARKINGS ARE APPROXIMATE. EXACT LOCATIONS WILL BE DETERMINED IN THE FIELD BY THE ENGINEER.
 - ALL MAINLINE PERMANENT STRIPING AND PAVEMENT MESSAGES SHALL BE PLACED WITHIN 72 HOURS OF MAINLINE PAVING.
 - SEE PERMANENT SIGN TABULATIONS FOR ADDITIONAL INFORMATION.
 - ALL SEGMENT STRIPE LINES SHALL BE EPOXY. PERMANENT MESSAGES AND ARROWS SHALL BE PREFORMED THERMOPLASTIC.
 - ALL SIGNS SHALL BE FURNISHED AND INSTALLED UNLESS OTHERWISE NOTED.
 - ALL SALVAGED SIGNS SHALL REMAIN IN PRISTINE CONDITION DURING REMOVAL AND INSTALLATION. SHALL BE PAID BY THE EACH ASSEMBLY, WHEN REINSTALLATION IS REQUIRED.
 - PROVIDE AND INSTALL A NEW SIGN STRUCTURE FOR TYPE C AND MARKERS AND INSTALL SALVAGED SIGN PANELS AS REQUIRED USING NEW NUTS, BOLTS AND WASHERS.
 - INSTALL SALVAGED SIGN ASSEMBLIES TO THE MOUNTING HEIGHTS AS SHOWN ON THE TABULATION.
 - SIGN TYPE SPECIAL ARE TO REMAIN VISIBLE AT ALL TIMES. SHALL BE PAID BY THE EACH, WHEN RELOCATION IS REQUIRED.
 - SALVAGED SIGNS SHALL REMAIN IN PRISTINE CONDITION DURING REMOVAL AND INSTALLATION. SHALL BE PAID BY THE EACH WHEN REINSTALLATION IS REQUIRED.

1	04/01/19	TV	ST	JR	UPDATES TO PERMANENT SIGNING AND STRIPING PLAN SHEETS
NO	DATE	BY	CKD	APPR	REVISION
NAME: P/02-618-032/Base/Traffic/Perm Striping					

I HEREBY CERTIFY THAT THIS PLAN WAS PREPARED BY ME OR UNDER MY DIRECT SUPERVISION AND THAT I AM A DULY LICENSED PROFESSIONAL ENGINEER UNDER THE LAWS OF THE STATE OF MINNESOTA.
 PRINT NAME: DOUGLAS W. FISCHER
 SIGNATURE: *[Signature]*
 DATE: 4/19/19 LICENSE NO. 20235

DRAWN BY: TV DATE: 09/20/18
 DESIGN BY: DATE: _____
 CHECKED BY: DATE: _____



ANOKA COUNTY
 HIGHWAY DEPT.

STATE PROJECT NO. 002-618-032
 STATE AID PROJECT NO. _____
 CITY PROJECT NO. _____
 COUNTY PROJECT NO. _____

SIGNING QUANTITIES
 Sheet 59 of 126 Sheets

REMOVE SHEET 60 OF 126

NO	DATE	BY	CKD	APPR	REVISION
1	04/01/19	TV	ST	JR	UPDATES TO PERMANENT SIGNING AND STRIPING PLAN SHEETS

NAME: P:/02-618-032/Base/Traffic/Sign&Stripe Details.dwg

I HEREBY CERTIFY THAT THIS PLAN WAS PREPARED BY ME OR UNDER MY DIRECT SUPERVISION AND THAT I AM A DULY REGISTERED PROFESSIONAL ENGINEER UNDER THE LAWS OF THE STATE OF MINNESOTA.
PRINT NAME: DOUGLAS W. FISCHER, P.E.
SIGNATURE: 
DATE: 4/10/19 REG. NO. 20235

DRAWN BY: TMV DATE: 04/04/18
DESIGN BY: _____ DATE: _____
CHECKED BY: _____ DATE: _____



ANOKA COUNTY
HIGHWAY DEPT.

STATE PROJECT NO. 002-618-032
STATE AID PROJECT NO. _____
CITY PROJECT NO. _____
COUNTY PROJECT NO. _____

SIGNING & STRIPING
DETAILS
Sheet 60 of 126 Sheet

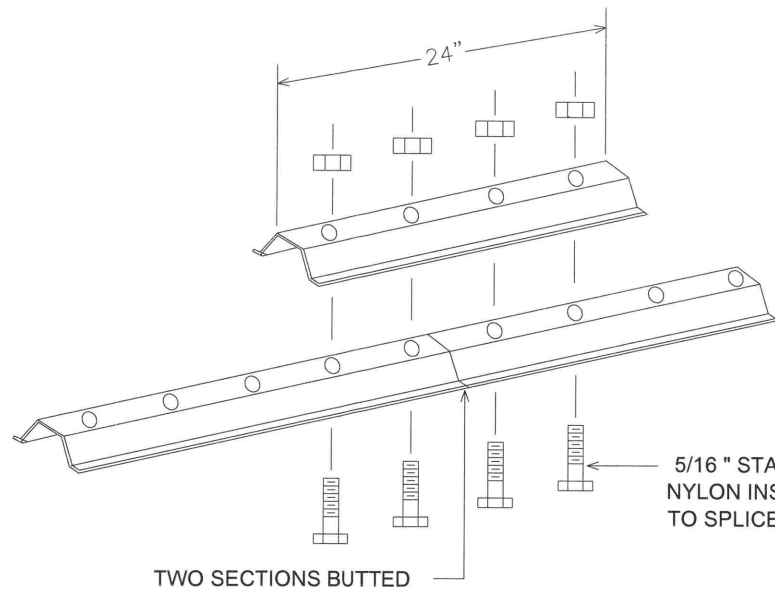

LATERAL BRACE OR STRINGER
SPlice DETAIL (EXPLODED VIEW)

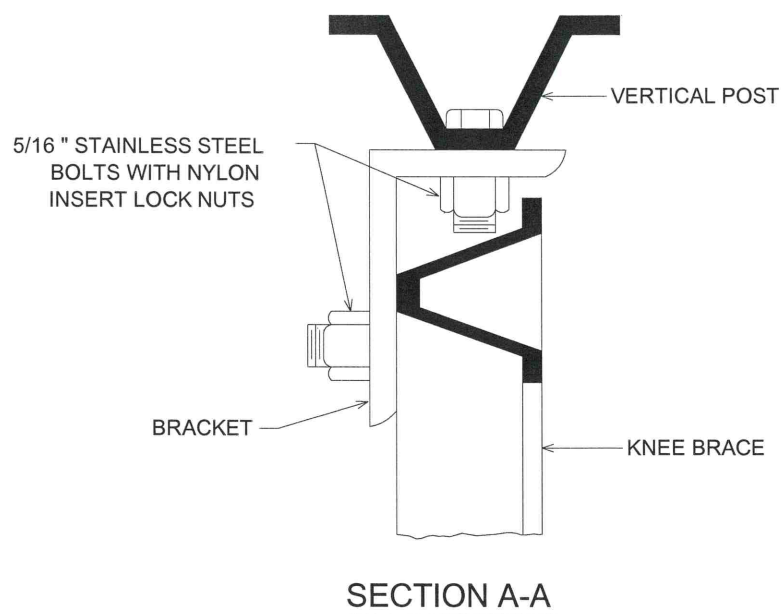

SECTION A-A

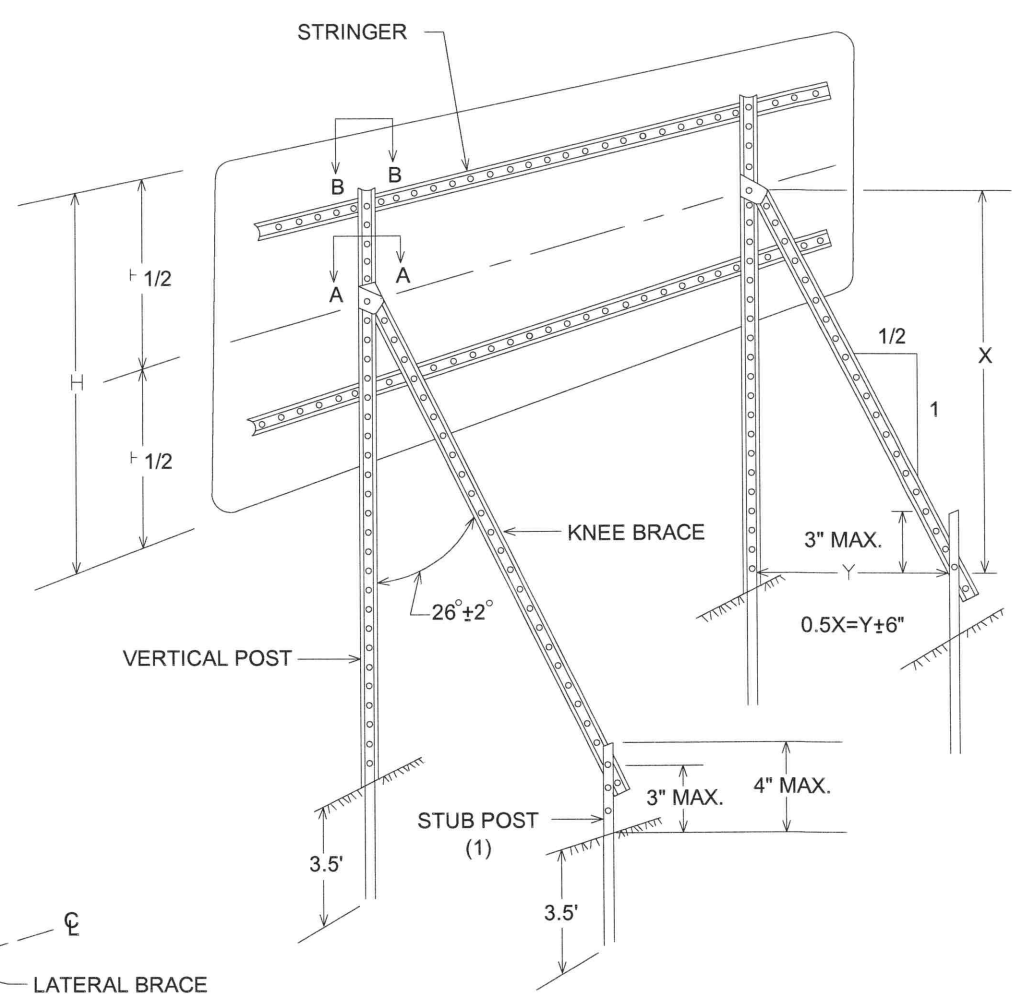

TYPICAL "A-FRAME" INSTALLATION
TYPE "D" SIGNS

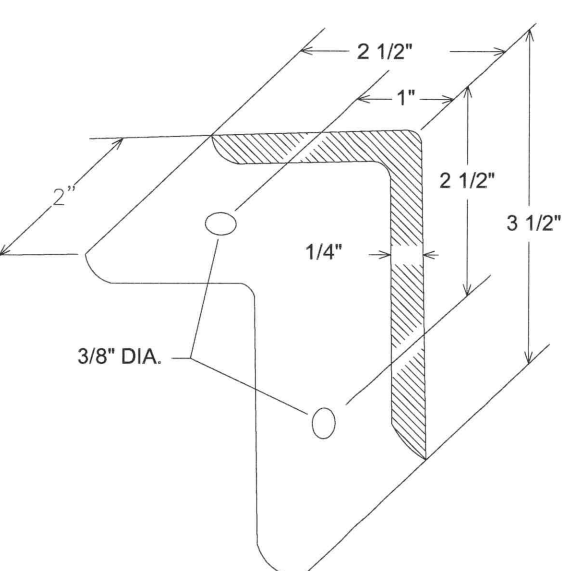

A-FRAME BRACKET
(STEEL MN/DOT 3306 GALVANIZED PER MN/DOT 3394)

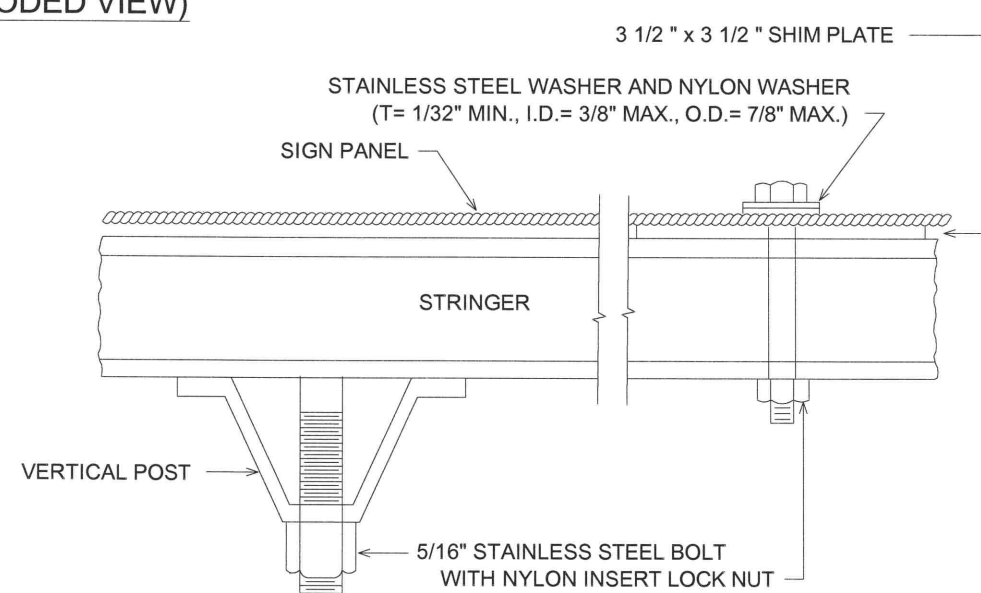

SECTION B-B

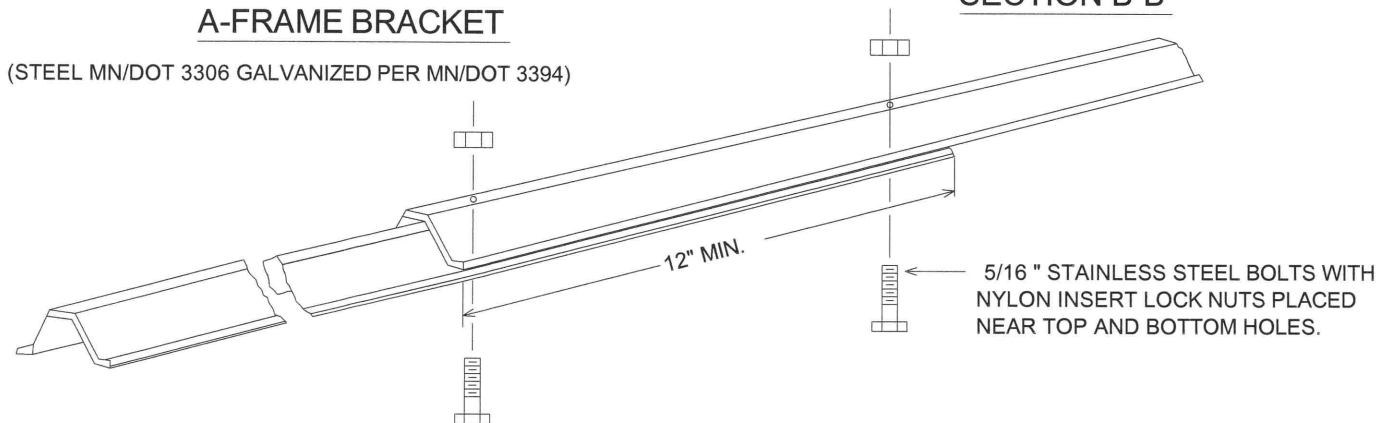

KNEE BRACE SPLICE

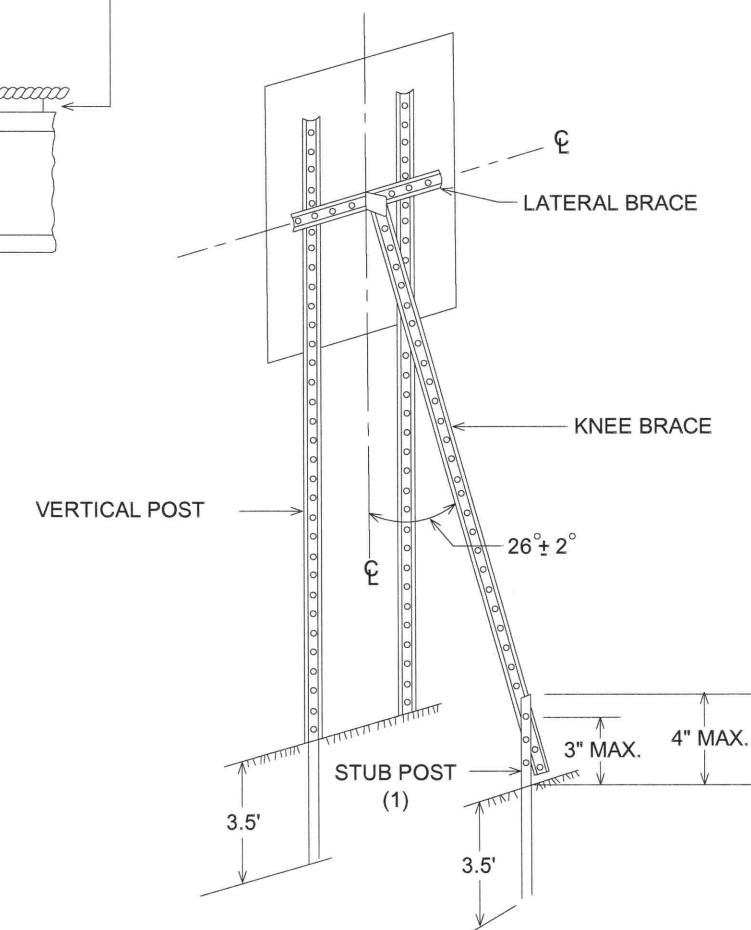

TYPICAL "A-FRAME" INSTALLATION
TYPE "C" SIGNS

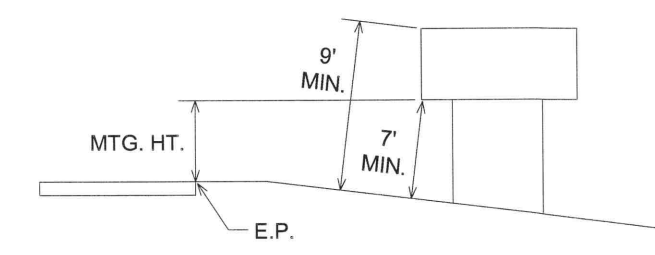

TYPICAL MOUNTING

(1) OFFSET STUB POST 1' TOWARD ROADWAY
RELATIVE TO VERTICAL POST.

TYPE C & D SIGN
STRUCTURAL DETAILS

1	04/01/19	TV	ST	JR	UPDATES TO PERMANENT SIGNING AND STRIPING PLAN SHEETS
NO	DATE	BY	CKD	APPR	REVISION
NAME: P:\02-618-032\Base\Traffic\Sign&Stripe Details.dwg					

I HEREBY CERTIFY THAT THIS PLAN WAS PREPARED BY ME OR UNDER MY DIRECT SUPERVISION AND THAT I AM A DULY REGISTERED PROFESSIONAL ENGINEER UNDER THE LAWS OF THE STATE OF MINNESOTA.
 PRINT NAME: DOUGLAS W. FISCHER, P.E.
 SIGNATURE: *[Signature]*
 DATE: 4/10/19 REG. NO. 20235

DRAWN BY: TMV DATE: 04/04/18
 DESIGN BY: DATE: _____
 CHECKED BY: DATE: _____



ANOKA COUNTY
HIGHWAY DEPT.

STATE PROJECT NO. 002-618-032
 STATE AID PROJECT NO. _____
 CITY PROJECT NO. _____
 COUNTY PROJECT NO. _____

SIGNING & STRIPING
DETAILS
 Sheet 61 of 126 Sheet

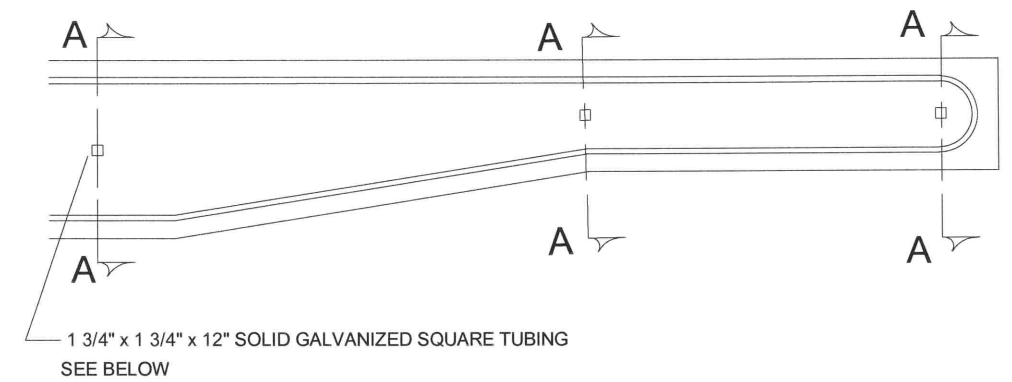
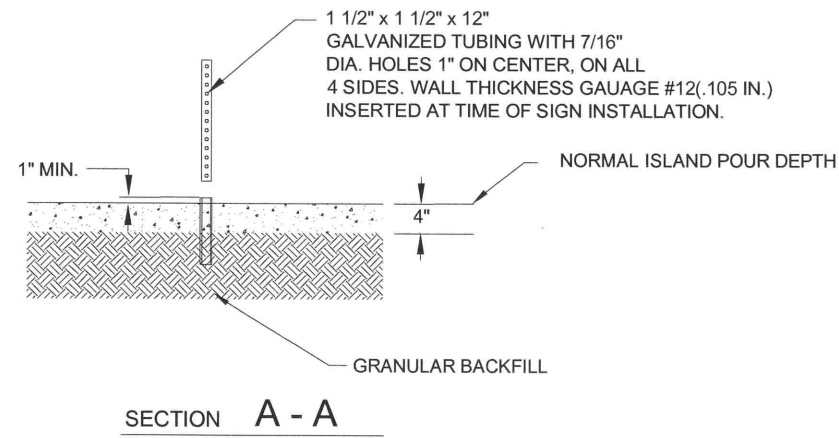

GROUND POST MOUNT SIGN INSTALLATION TYPICAL

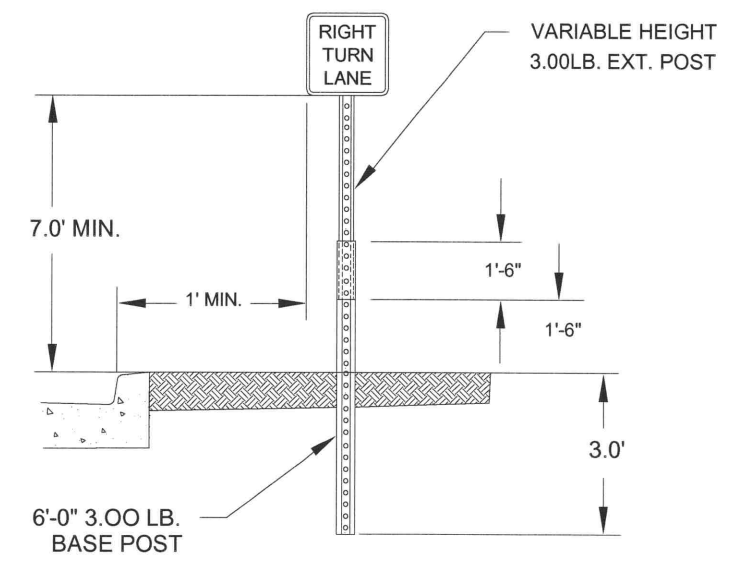

ISLAND MOUNT BREAK-AWAY SIGN INSTALLATION TYPICAL

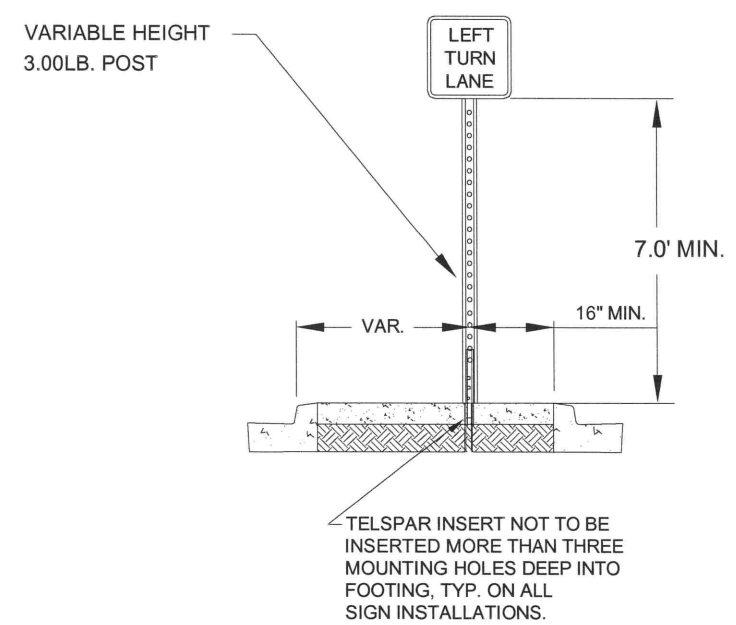

ISLAND MOUNT BREAK-AWAY SIGN SIGN INSTALLATION TYPICAL
KEEP RIGHT/CLUSTER

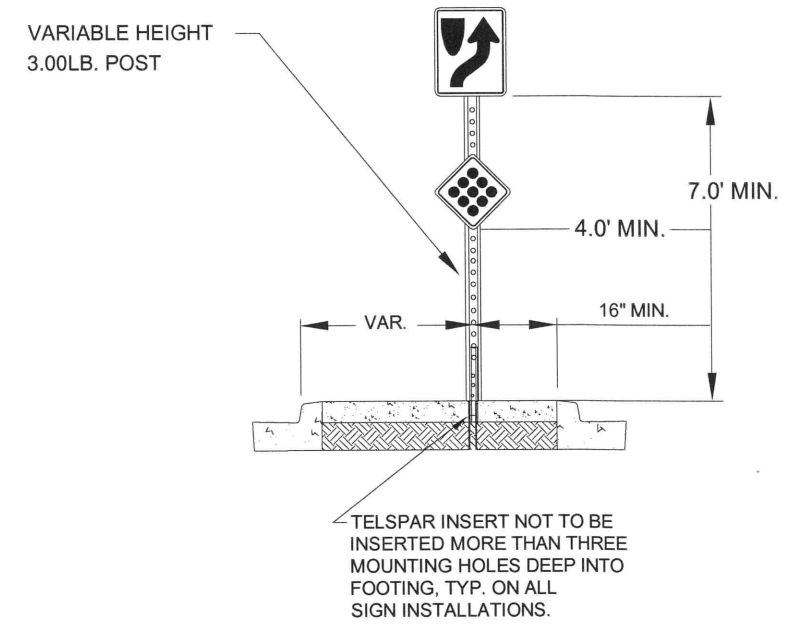

1	04/01/19	TV	ST	JR	UPDATES TO PERMANENT SIGNING AND STRIPING PLAN SHEETS
NO	DATE	BY	CKD	APPR	REVISION
NAME: P:/02-618-032/Base/Traffic/Sign&Stripe Details.dwg					

I HEREBY CERTIFY THAT THIS PLAN WAS PREPARED BY ME OR UNDER MY DIRECT SUPERVISION AND THAT I AM A DULY REGISTERED PROFESSIONAL ENGINEER UNDER THE LAWS OF THE STATE OF MINNESOTA.

PRINT NAME: DOUGLAS W. FISCHER, P.E.

SIGNATURE: *[Signature]*

DATE: 4/19/19 REG. NO. 20235

DRAWN BY: TMV DATE: 04/04/18

DESIGN BY: DATE:

CHECKED BY: DATE:

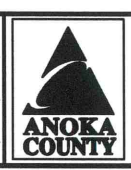

ANOKA COUNTY
HIGHWAY DEPT.

STATE PROJECT NO. 002-618-032

STATE AID PROJECT NO. _____

CITY PROJECT NO. _____

COUNTY PROJECT NO. _____

SIGNING & STRIPING
DETAILS

Sheet 62 of 126 Sheets

TYPICAL SIGN PLACEMENT
(RURAL)

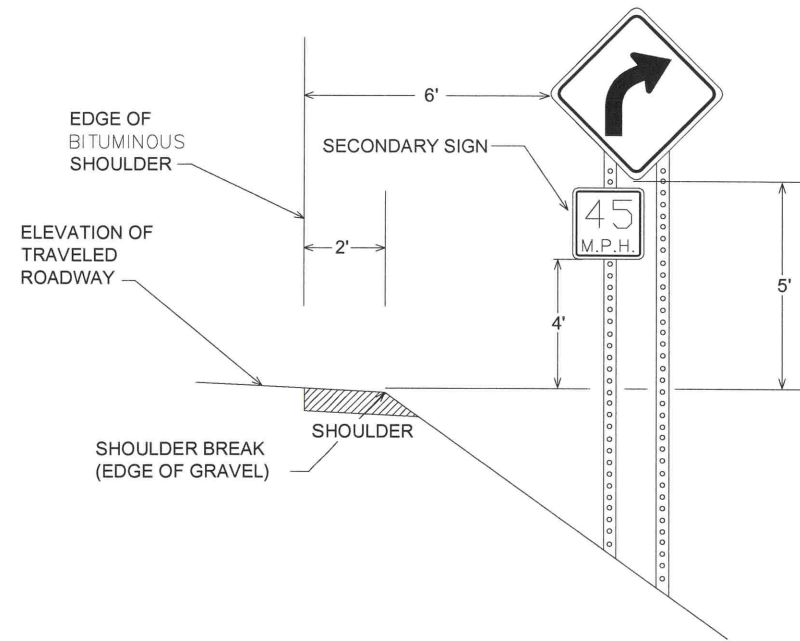

TYPICAL SIGN PLACEMENT
(URBAN)

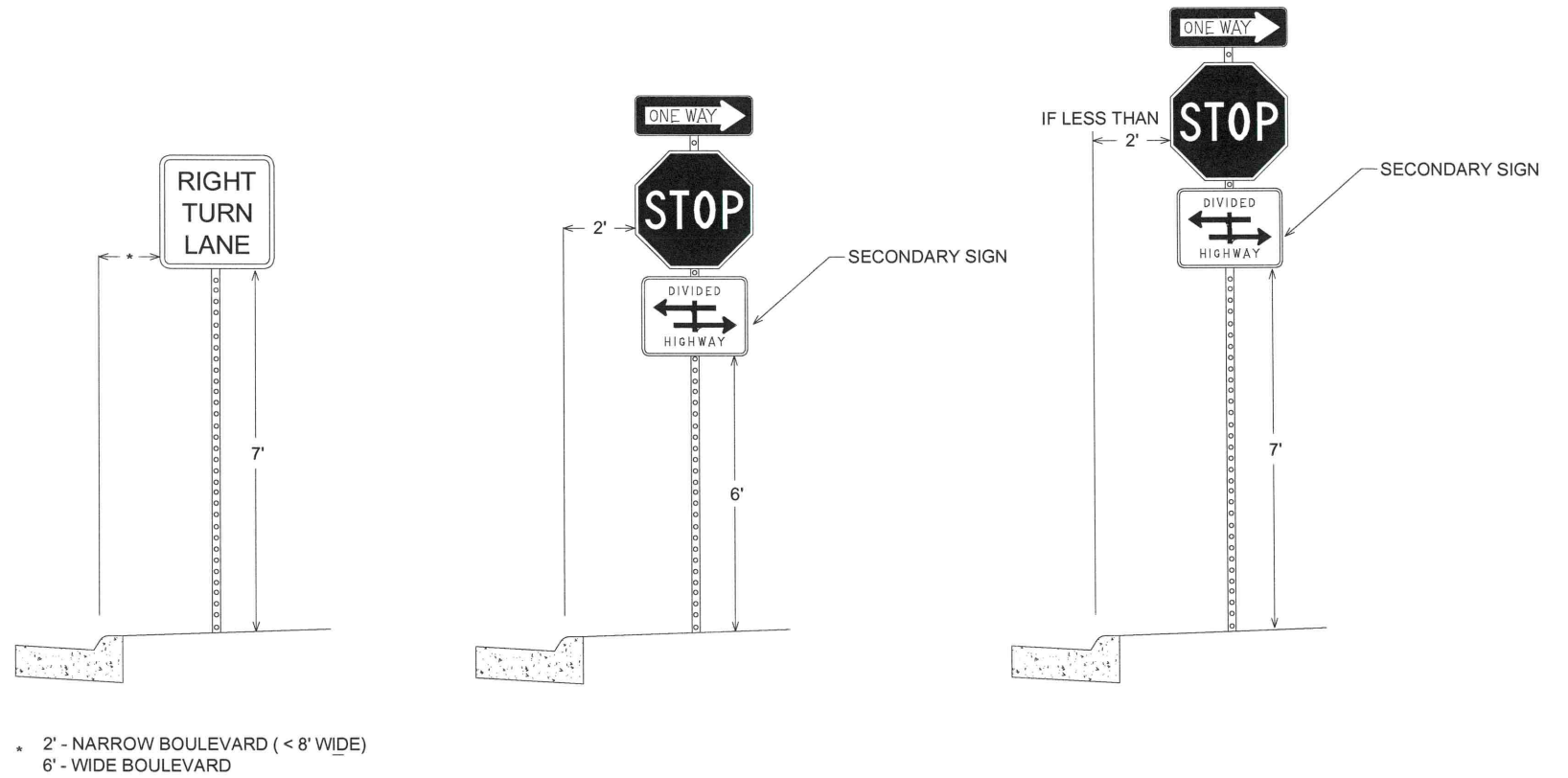

NOTES:

- ALL DIMENSIONS ARE MINIMUMS
- MAINTAIN A CLEAR DISTANCE OF 2' BETWEEN SIGNS AND BITUMINOUS TRAIL
- 7' SIGN CLEARANCE IF A CLEAR DISTANCE OF 2' BETWEEN SIGNS AND BITUMINOUS TRAIL CANNOT BE MAINTAINED

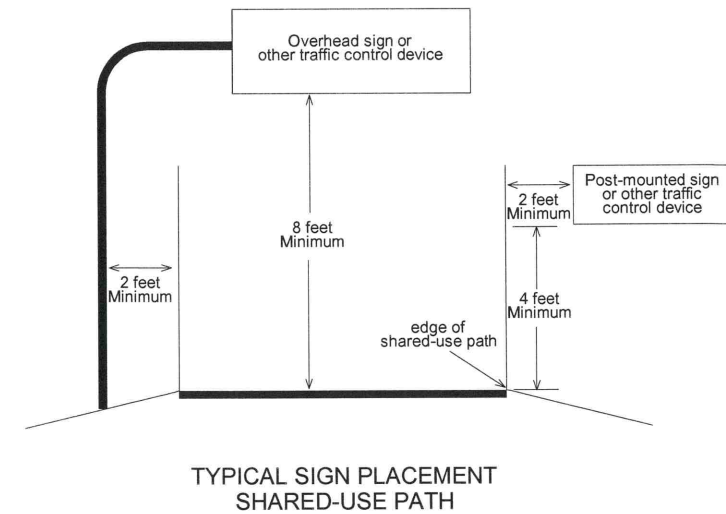

1	04/01/19	TV	ST	JR	UPDATES TO PERMANENT SIGNING AND STRIPING PLAN SHEETS
NO	DATE	BY	CKD	APPR	REVISION
NAME: P:/02-618-032/Base/Traffic/Sign&Stripe Details.dwg					

I HEREBY CERTIFY THAT THIS PLAN WAS PREPARED BY ME OR UNDER MY DIRECT SUPERVISION AND THAT I AM A DULY REGISTERED PROFESSIONAL ENGINEER UNDER THE LAWS OF THE STATE OF MINNESOTA.
 PRINT NAME: DOUGLAS W. FISCHER, P.E.
 SIGNATURE: *[Signature]*
 DATE: 4/10/19 REG. NO. 20235

DRAWN BY: TMV DATE: 04/04/18
 DESIGN BY: _____ DATE: _____
 CHECKED BY: _____ DATE: _____



ANOKA COUNTY
HIGHWAY DEPT.

STATE PROJECT NO. 002-618-032
 STATE AID PROJECT NO. _____
 CITY PROJECT NO. _____
 COUNTY PROJECT NO. _____

SIGNING & STRIPING
DETAILS
 Sheet 63 of 126 Sheets

**TYPICAL MESSAGE PLACEMENT
FOR TURN LANES**

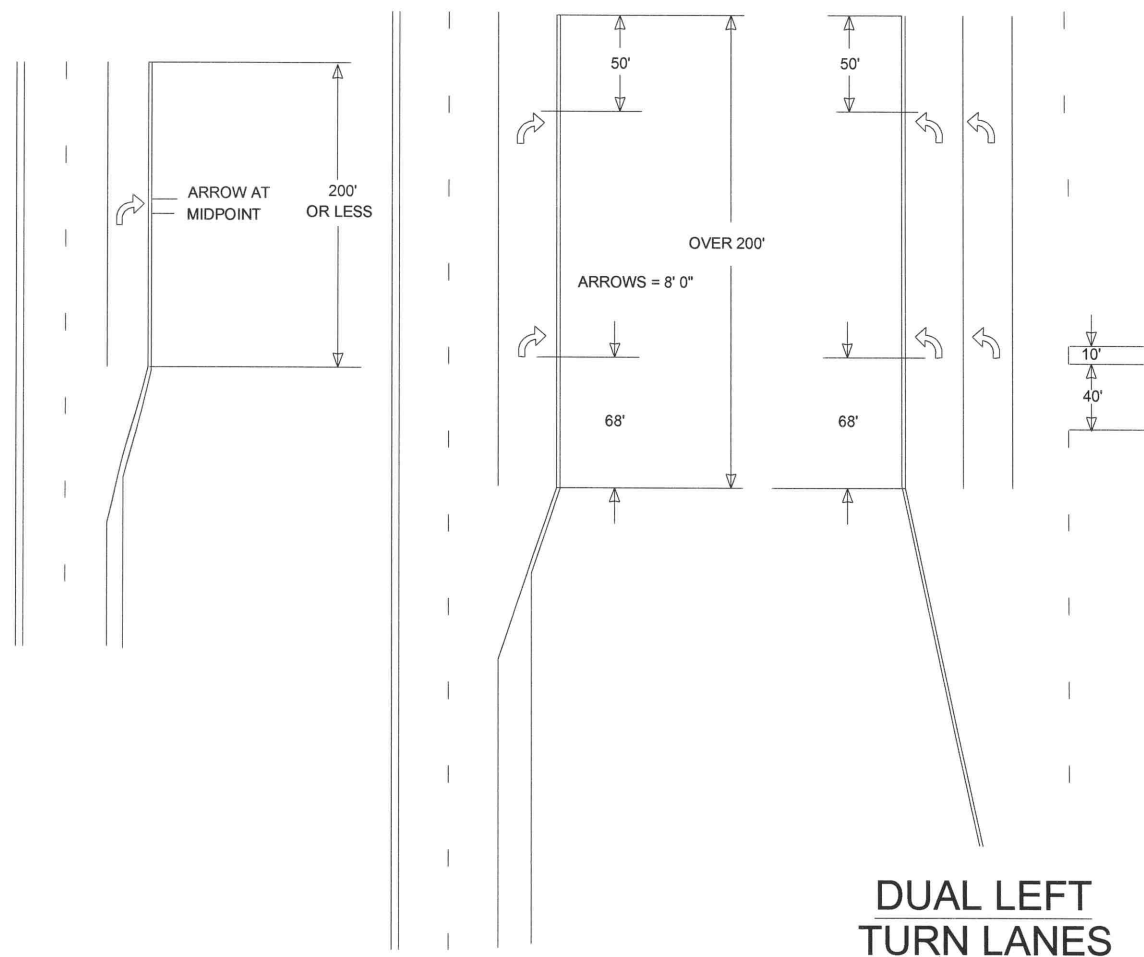

**TYPICAL MARKINGS FOR
LEFT TURN ISLANDS**

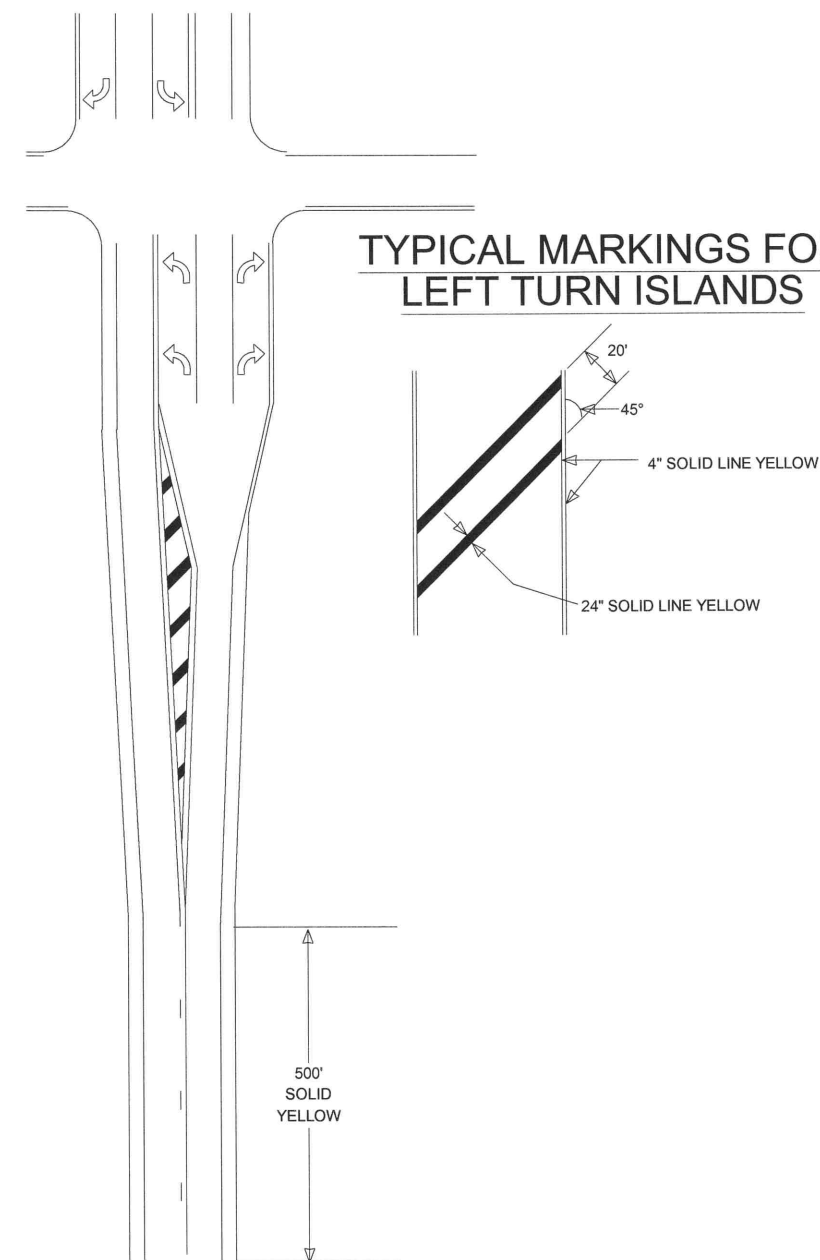

1	04/01/19	TV	ST	JR	UPDATES TO PERMANENT SIGNING AND STRIPING PLAN SHEETS
NO	DATE	BY	CKD	APPR	REVISION
NAME: P:/02-618-032/Base/Traffic/Sign&Stripe Details.dwg					

I HEREBY CERTIFY THAT THIS PLAN WAS PREPARED BY ME OR UNDER MY DIRECT SUPERVISION AND THAT I AM A DULY REGISTERED PROFESSIONAL ENGINEER UNDER THE LAWS OF THE STATE OF MINNESOTA.

PRINT NAME: DOUGLAS W. FISCHER, P.E.

SIGNATURE: *[Signature]*

DATE: 4/19/19 REG. NO. 20235

DRAWN BY: TMV DATE: 04/04/18

DESIGN BY: DATE:

CHECKED BY: DATE:



**ANOKA COUNTY
HIGHWAY DEPT.**

STATE PROJECT NO. 002-618-032

STATE AID PROJECT NO. _____

CITY PROJECT NO. _____

COUNTY PROJECT NO. _____

**SIGNING & STRIPING
DETAILS**

MARKINGS FOR PEDESTRIAN CROSSWALKS

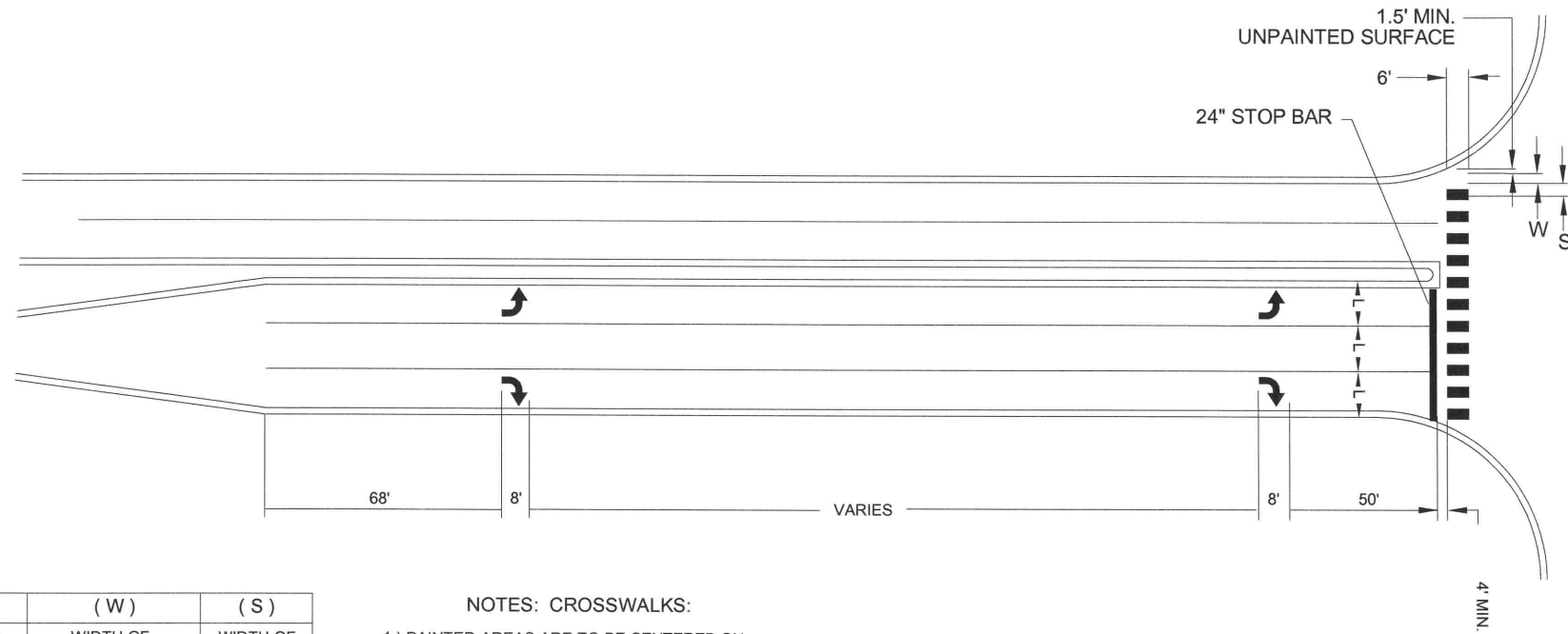

(L)	(W)	(S)
WIDTH OF INSIDE LANE	WIDTH OF PAINTED AREAS	WIDTH OF SPACE
9'	2.0'	2.5'
10'	2.5'	2.5'
11'	2.5'	3.0'
12'	3.0'	3.0'
13'	3.0'	3.5'

NOTES: CROSSWALKS:

- 1.) PAINTED AREAS ARE TO BE CENTERED ON CENTER AND LANE LINES, EVEN IF INTERSECTION IS NOT ALIGNED.
- 2.) LOCATION OF ZEBRA CROSSWALKS AND STOP BARS, SIGNAL LOOPS AND PED RAMPS ARE APPROXIMATE. FINAL LOCATIONS ARE TO BE DETERMINED AND FIELD VERIFIED DURING CONSTRUCTION BY THE FIELD ENGR.
- 3.) ZEBRA CROSSWALKS ARE TO BE PARALLEL TO THE DRIVING LANE OR LANES, EVEN IF THE STREET IS ON AN ANGLE TO THE INTERSECTION.
- 4.) A MIN. OF 1.5' (450mm) CLEAR DISTANCE MUST BE LEFT ADJACENT TO THE CURB. IF LAST PAINTED AREA FALLS INTO THIS AREA, IT MUST BE OMITTED.
- 5.) ON TWO LANE STREETS, USE SPACING SHOWN FOR AN 11' (3.3mm) INSIDE LANE.

1	04/01/19	TV	ST	JR	UPDATES TO PERMANENT SIGNING AND STRIPING PLAN SHEETS
NO	DATE	BY	CKD	APPR	REVISION
NAME: P:\02-618-032\Base\Traffic\Sign&Stripe Details.dwg					

I HEREBY CERTIFY THAT THIS PLAN WAS PREPARED BY ME OR UNDER MY DIRECT SUPERVISION AND THAT I AM A DULY REGISTERED PROFESSIONAL ENGINEER UNDER THE LAWS OF THE STATE OF MINNESOTA.

PRINT NAME: DOUGLAS W. FISCHER, P.E.
 SIGNATURE: *[Signature]*
 DATE: 4/10/19 REG. NO. 20235

DRAWN BY: TMV DATE: 04/04/18
 DESIGN BY: DATE: _____
 CHECKED BY: DATE: _____

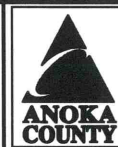

ANOKA COUNTY
 HIGHWAY DEPT.

STATE PROJECT NO. 002-618-032
 STATE AID PROJECT NO. _____
 CITY PROJECT NO. _____
 COUNTY PROJECT NO. _____

SIGNING & STRIPING
 DETAILS

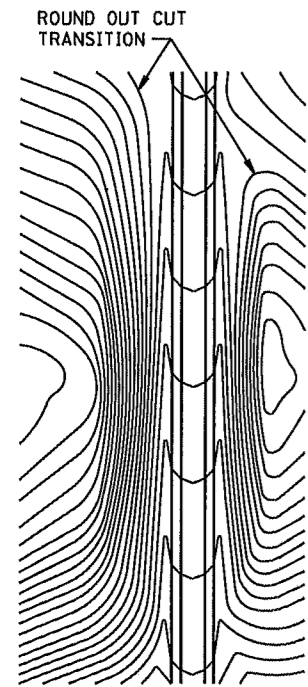

CONTOURING ROAD CUTS

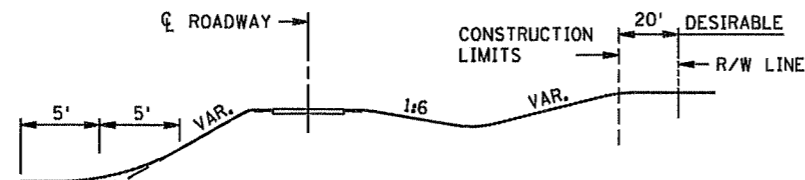

ROUNDING SHOULDERS AND BACKSLOPES

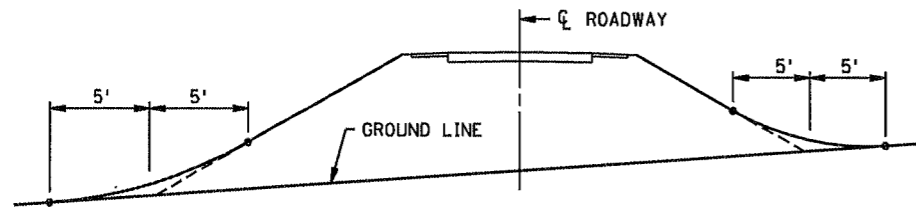

SHAPING FOR DRAINAGE ALONG THE TOE OF FILL SLOPES

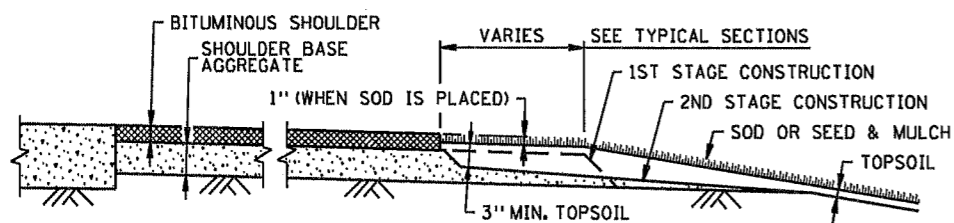

SHAPING AND TOPSOILING INSLOPES

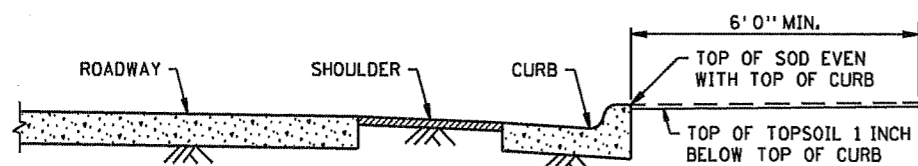

SHAPING ADJACENT TO CURBS WHEN SOD IS PLACED

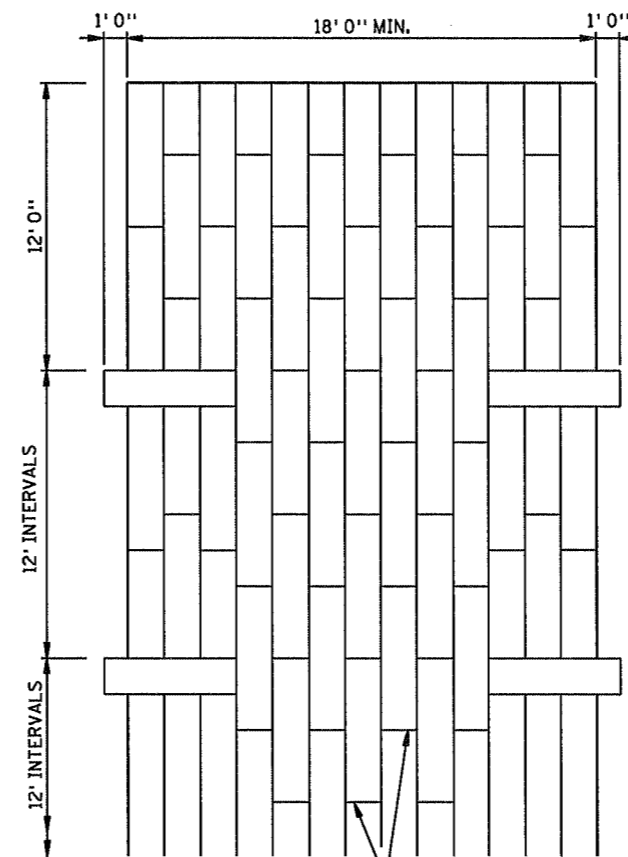

STAGGER JOINTS
PLAN VIEW

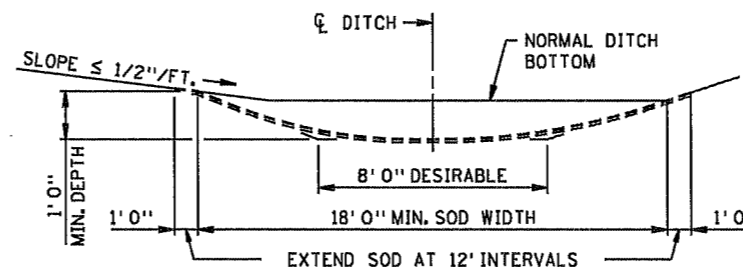

SODDED DITCH CROSS SECTION
WHERE FRONT OR BACK SLOPE IS FLAT (LESS THAN 1/2"/FT.),
FIRST NOTCH DITCH AND THEN PROVIDE ROUNDING.

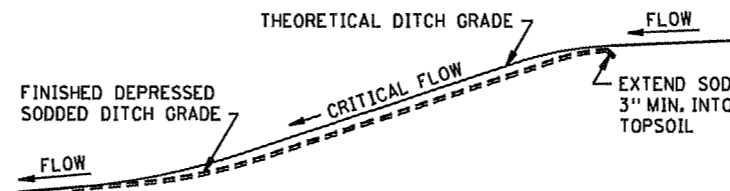

DITCH PROFILE
SODDED DITCH DETAILS

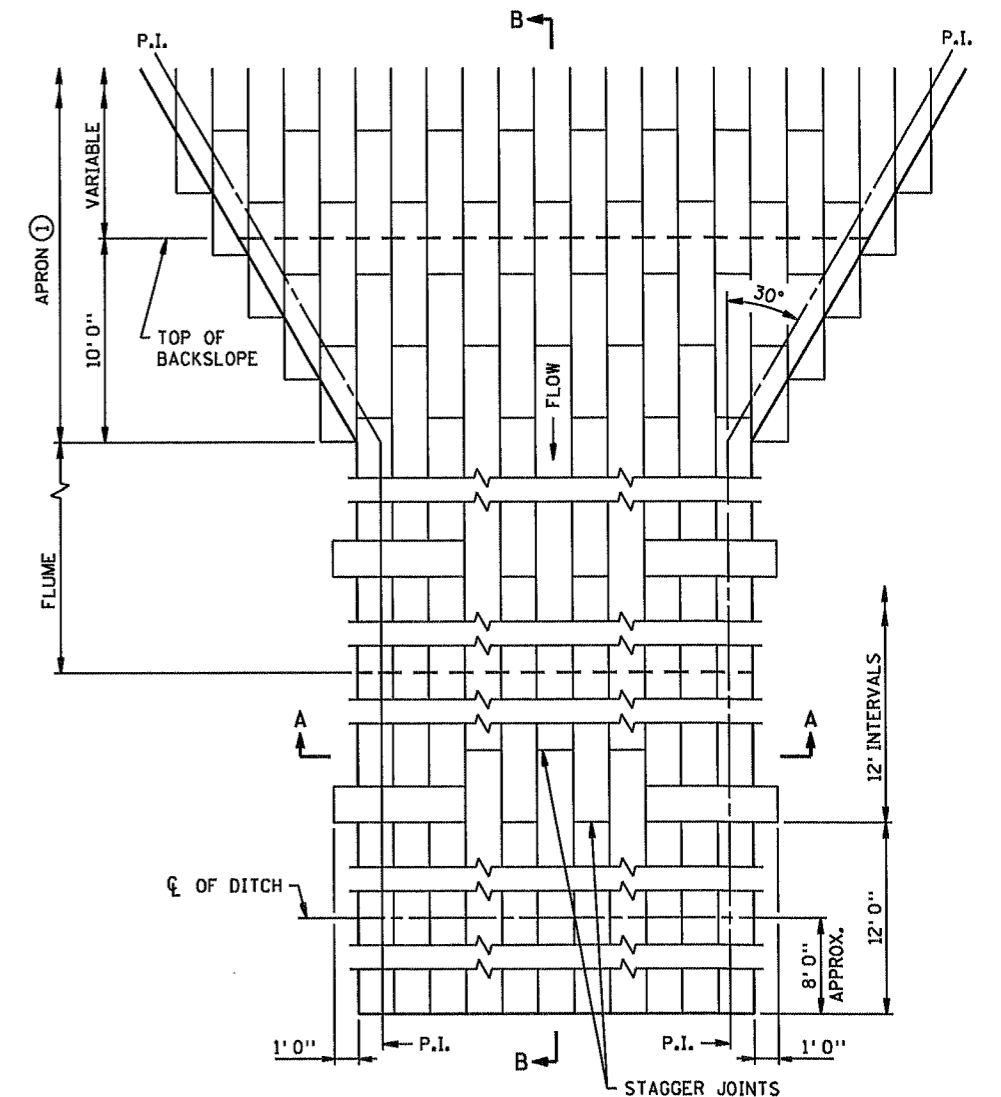

PLAN VIEW

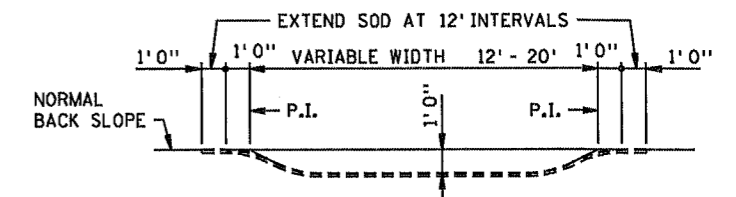

SECTION A-A

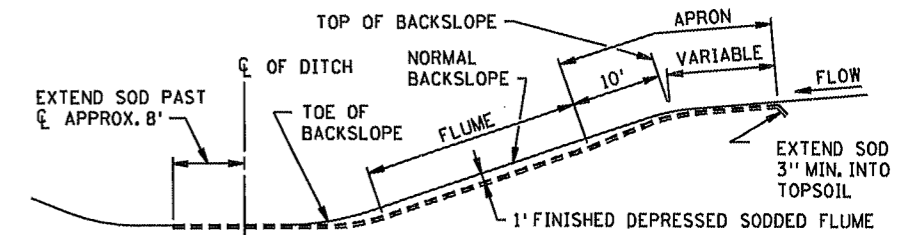

SECTION B-B
SODDED FLUME DETAILS

NOTES:
SEE SPEC. 2575.3 FOR ADDITIONAL INFORMATION.
① CONSTRUCT TAPER AS DIRECTED BY THE ENGINEER.

REVISION:
APPROVED: 2-28-2017
Chief Environmental Officer

MINNESOTA
DEPARTMENT OF TRANSPORTATION
STATE DESIGN ENGINEER
APPROVED: 2-28-2017

PERMANENT EROSION CONTROL
ALONG ROADWAYS, DITCHES AND FLUMES
STANDARD PLAN 5-297.404
SP 002-678-022
SP 198-020-037
66 OF 126

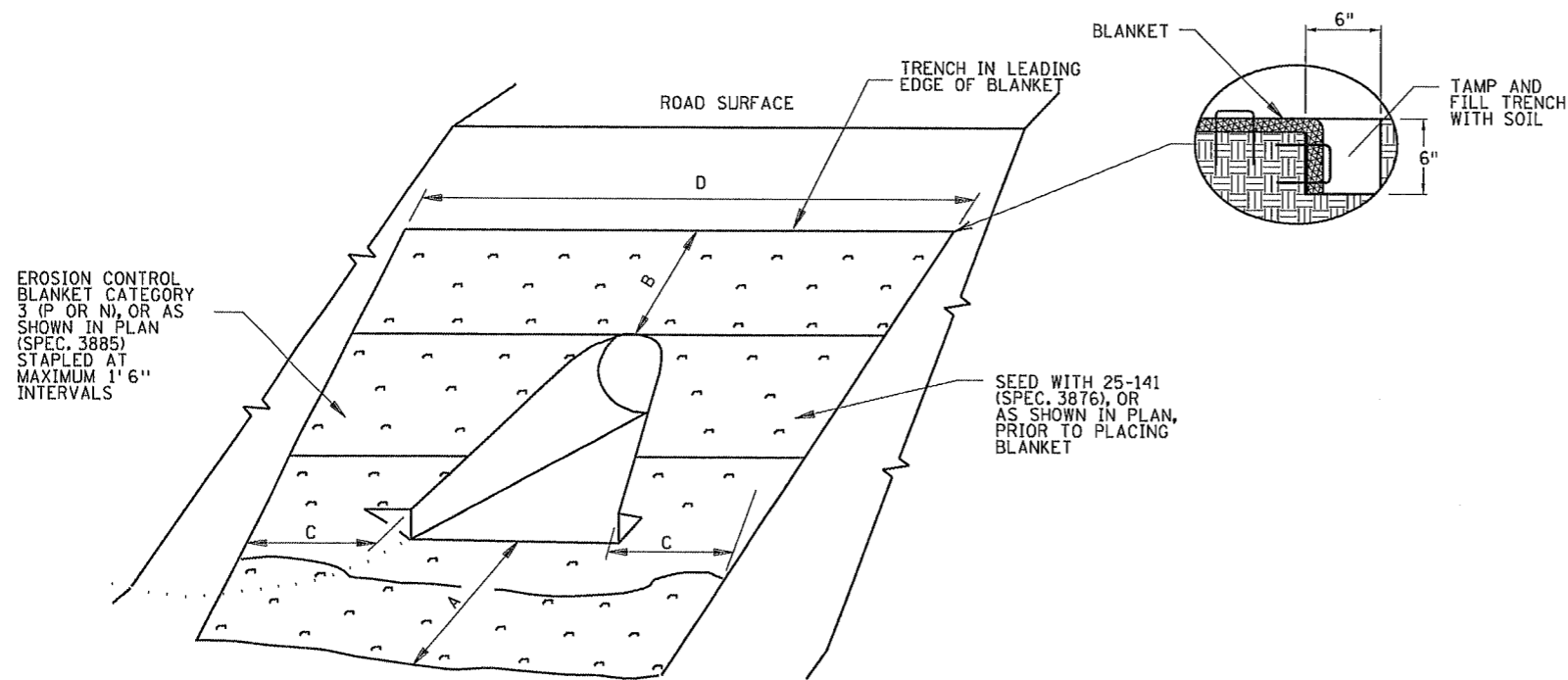

EROSION CONTROL BLANKET & SEED DETAIL

CULVERT DIAMETER ②	SOD OR EROSION CONTROL BLANKET (SQ. YDS.)						"A"	"B"	"C"	"D"
	CIRCULAR AND ARCH PIPE METAL APRON (PLATE 3123, PLATE 3122)	CIRCULAR AND ARCH PIPE CONCRETE APRON (PLATE 3100, PLATE 3110)	CIRCULAR AND ARCH PIPE METAL SAFETY APRON 1:4 SLOPE (PLATE 3148)	CIRCULAR AND ARCH PIPE METAL SAFETY APRON 1:6 SLOPE (PLATE 3148)	CIRCULAR CORRUGATED METAL PIPE SAFETY APRON 1:6 SLOPE (PLATE 3128)	CIRCULAR CORRUGATED METAL PIPE SAFETY APRON 1:4 SLOPE (PLATE 3128)				
15"	9	9	8	8	N/A	N/A	3'	1.5'	3'	13'
18"	13	12	12	14	16	N/A	3'	3'	3'	16'
21"	14	14	14	16	18	14	3'	3'	3'	17'
24"	16	15	16	19	21	17	3'	3'	3'	18'
27"	N/A	20	N/A	N/A	N/A	N/A	3'	4.5'	3'	20'
30"	23	22	25	30	32	N/A	3'	4.5'	3'	22'
36"	34	34	39	48	51	37	4.5'	4.5'	4.5'	27'
42"	43	40	51	64	N/A	N/A	4.5'	6'	4.5'	30'
48"	54	50	66	82	N/A	N/A	4.5'	7.5'	4.5'	34'
54"	65	58	81	102	N/A	N/A	4.5'	9'	4.5'	37'
60"	69	59	91	115	N/A	N/A	4.5'	9'	4.5'	39'
66"	69	63	N/A	N/A	N/A	N/A	4.5'	9'	4.5'	39'
72"	78	72	99	122	N/A	N/A	4.5'	10.5'	4.5'	41'

CULVERT DIAMETER ②	SOD OR EROSION CONTROL BLANKET (SQ. YDS.)						"A"	"B"	"C"	"D"
	CIRCULAR AND ARCH PIPE METAL APRON (PLATE 3123, PLATE 3122)	CIRCULAR AND ARCH PIPE CONCRETE APRON (PLATE 3100, PLATE 3110)	CIRCULAR AND ARCH PIPE METAL SAFETY APRON 1:4 SLOPE (PLATE 3148)	CIRCULAR AND ARCH PIPE METAL SAFETY APRON 1:6 SLOPE (PLATE 3148)	CIRCULAR CORRUGATED METAL PIPE SAFETY APRON 1:6 SLOPE (PLATE 3128)	CIRCULAR CORRUGATED METAL PIPE SAFETY APRON 1:4 SLOPE (PLATE 3128)				
15"	10	10	9	10	N/A	N/A	4.5'	1.5'	3'	13'
18"	13	13	12	14	15	N/A	6'	1.5'	3'	14'
21"	16	14	16	18	19	15	6'	1.5'	3'	15'
24"	18	18	18	21	22	18	7.5'	1.5'	3'	16'
27"	N/A	19	N/A	N/A	N/A	N/A	7.5'	1.5'	3'	17'
30"	23	23	24	28	29	N/A	9'	1.5'	3'	18'
36"	36	35	38	47	48	37	10.5'	1.5'	4.5'	23'
42"	43	40	47	58	N/A	N/A	12'	1.5'	4.5'	25'
48"	50	46	57	70	N/A	N/A	13.5'	1.5'	4.5'	27'
54"	57	50	67	84	N/A	N/A	15'	1.5'	4.5'	29'
60"	74	63	90	113	N/A	N/A	16.5'	1.5'	6'	33'
66"	75	67	N/A	N/A	N/A	N/A	16.5'	1.5'	6'	33'
72"	77	70	92	114	N/A	N/A	16.5'	1.5'	6'	34'

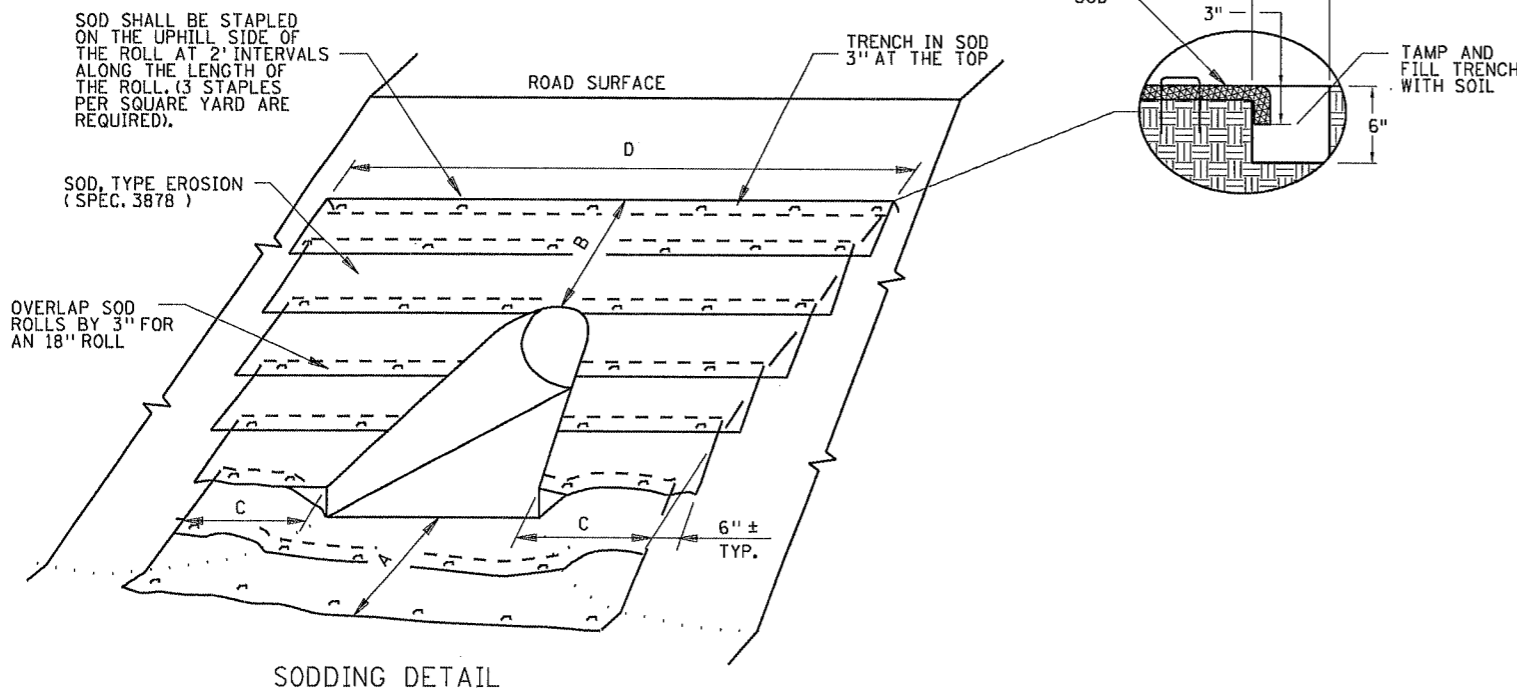

SODDING DETAIL

NOTES:

- AREA SHOWN IN SQUARE YARDS IS FOR ONE CULVERT END.
- QUANTITIES ARE CALCULATED TO INCLUDE SOD REQUIRED TO PROVIDE A 3" OVERLAP ON ALL 18" WIDE ROLLS. THIS ALLOWS FOR SHRINKAGE OF THE SOD.
- FOR PIPE ARCHES USE EQUIVALENT PIPE DIAMETER TO APPROXIMATE AREA.
- FOR CORRUGATED POLYETHYLENE PIPE METAL APRON (PLATE 3129), USE THE METAL APRON COLUMN (PLATE 3123).
- AREAS AND DIMENSIONS ARE APPROXIMATE AND ARE BASED ON APRON SIDE SLOPES OF NO STEEPER THAN 1:2, UNLESS INDICATED AS FOR SAFETY APRONS.
- CARE SHOULD BE TAKEN IN SELECTING SOD TO STABILIZE THE APRON. RIP-RAP SHOULD BE USED FOR FLOW VELOCITIES GREATER THAN 6 FPS.

- ① ADDITIONAL QUANTITIES MAY BE SHOWN IN THE PLAN OR REQUIRED BY THE ENGINEER.
- ② FOR ARCH PIPE USE CLOSEST CIRCULAR PIPE DIAMETER AND APRON SLOPE. (DIAMETERS LARGER THAN 72" REQUIRE SPECIAL DESIGNS.)

REVISION:
APPROVED: 2-28-2017
Chief Environmental Officer
CHIEF ENVIRONMENTAL OFFICER

m
MINNESOTA
DEPARTMENT
OF
TRANSPORTATION

REVISOR:
Tom S...
APPROVED:
2-28-2017
STATE DESIGN ENGINEER

PERMANENT EROSION CONTROL
TURF ESTABLISHMENT DETAIL AT CULVERT ENDS
STANDARD PLAN 5-297.404
SP 002-678-022
SP 198-020-037

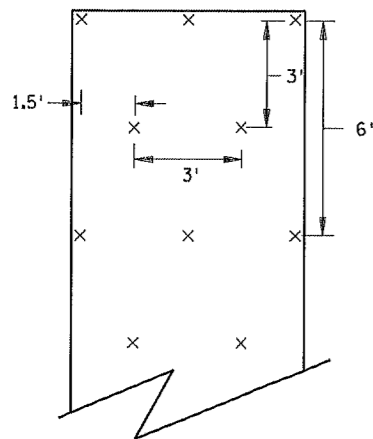

SLOPES FLATTER THAN 1:2
(120 STAPLES PER 100 SQ YD)

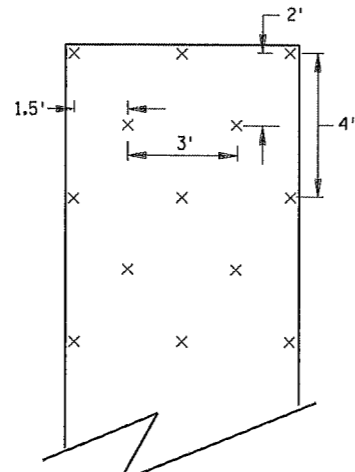

SLOPES 1:2 TO 1:1
(170 STAPLES PER 100 SQ YD)

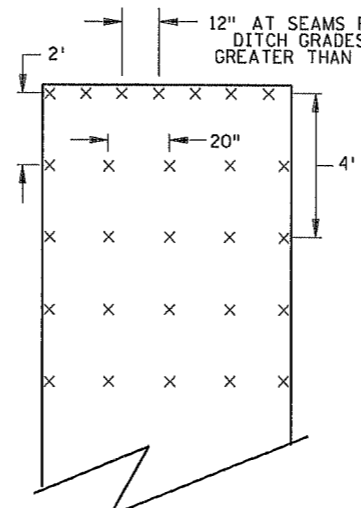

CHANNEL AND DITCH APPLICATIONS
(350 STAPLES PER 100 SQ YD)

BLANKET STAPLE PATTERN

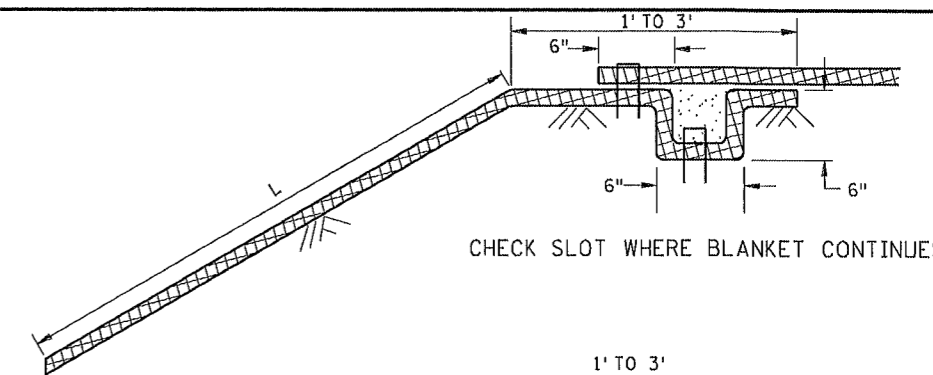

CHECK SLOT WHERE BLANKET CONTINUES

CHECK SLOT 1/3 FROM TOE OF SLOPE WHEN L IS GREATER THAN 100'

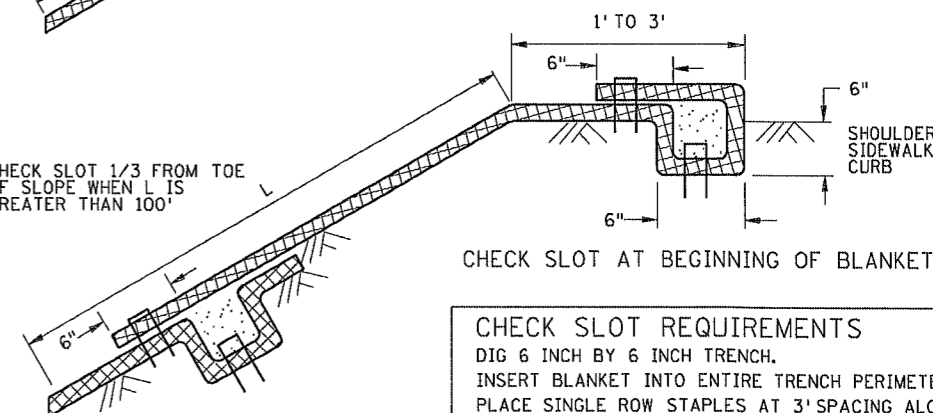

CHECK SLOT AT BEGINNING OF BLANKET

CHECK SLOT REQUIREMENTS
DIG 6 INCH BY 6 INCH TRENCH.
INSERT BLANKET INTO ENTIRE TRENCH PERIMETER.
PLACE SINGLE ROW STAPLES AT 3' SPACING ALONG THE BOTTOM OF THE TRENCH.
BACKFILL TRENCH WITH SOIL AND TAMP.
PLACE SINGLE ROW STAPLES AT 3' SPACING ON OVERLAP.

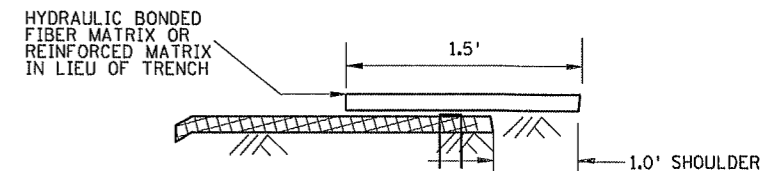

CHECK SLOT ALTERNATIVE
PLACE SINGLE ROW STAPLES AT 12" SPACING
CHECK SLOT DETAILS

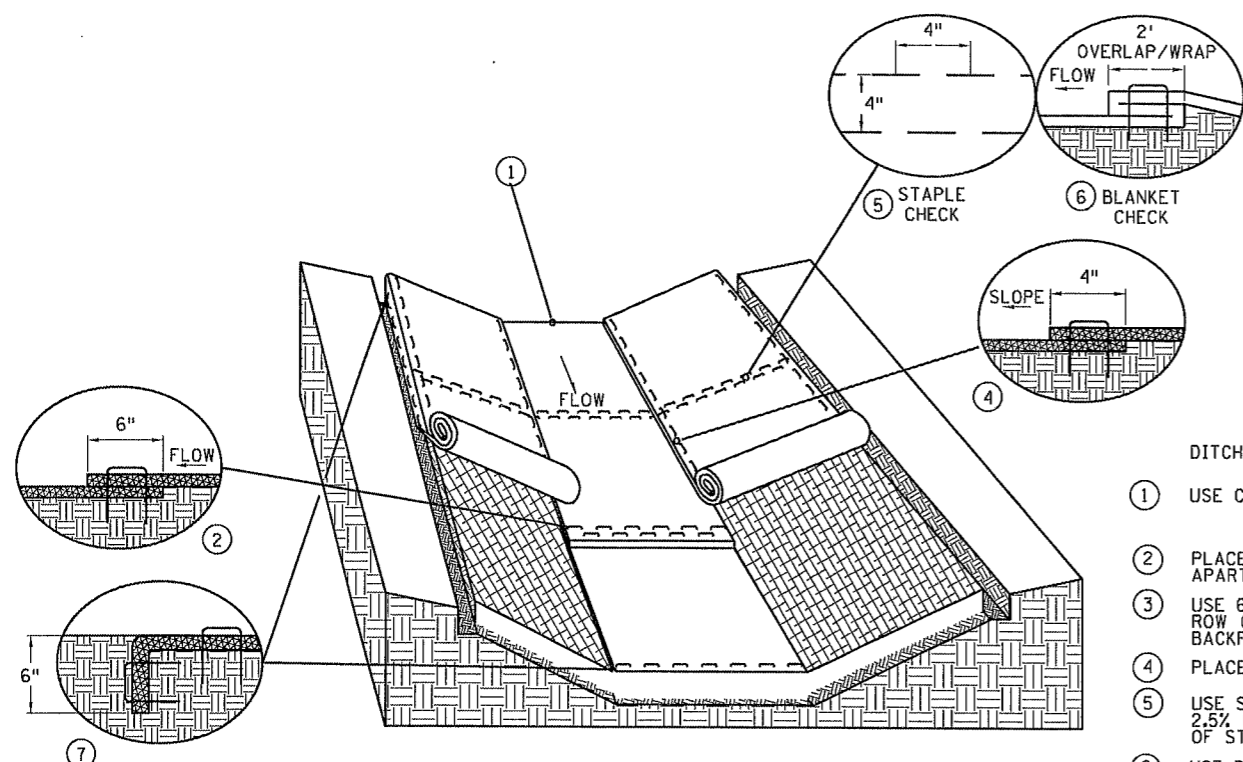

DITCH BLANKET STAPLE DETAIL

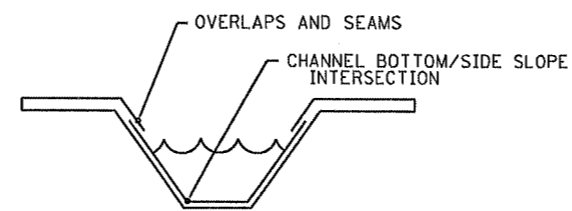

DITCH BLANKET CRITICAL POINTS ⑦

DITCH BLANKET STAPLE DETAIL NOTES

- ① USE CHECK SLOT DETAIL (NO ALTERNATES).
- ② PLACE DOUBLE ROW OF STAPLES STAGGERED 4" APART AND 4" ON CENTER.
- ③ USE 6" X 6" TRENCH TO PLACE BLANKET. PLACE SINGLE ROW OF STAPLES ON TOP AND TRENCH SIDES AT 12" SPACING. BACKFILL TRENCH WITH SOIL AND TAMP.
- ④ PLACE SINGLE ROW OF STAPLES AT 12" SPACING.
- ⑤ USE STAPLE CHECK FOR CHANNEL SLOPES LESS THAN 2.5% GRADE AT 100 FOOT INTERVALS. PLACE DOUBLE ROW OF STAPLES STAGGERED 4" APART AND AT 4" SPACING.
- ⑥ USE BLANKET CHECKS FOR THE FOLLOWING SLOPES:
2.5%-3% 100 FT INTERVALS
3%-5% 50 FT INTERVALS
5%-7% 25 FT INTERVALS
- ⑦ CRITICAL POINTS SHALL BE SECURED WITH PROPER STAPLE PATTERNS.

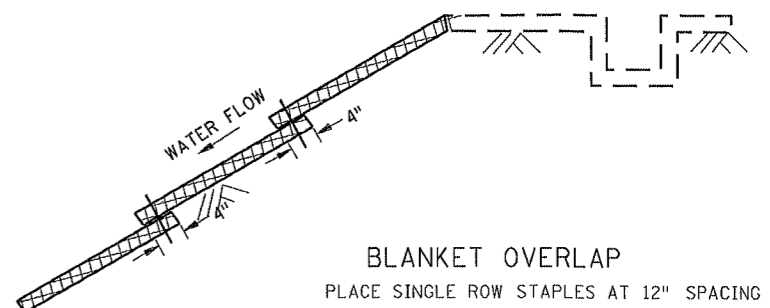

BLANKET OVERLAP

PLACE SINGLE ROW STAPLES AT 12" SPACING

GENERAL BLANKET INSTALLATION REQUIREMENTS

PREPARE SOIL AS PER SPECIFICATION 2574.
LAY PARALLEL OR PERPENDICULAR TO THE DIRECTION OF WATER FLOW.
OVERLAP ADJACENT STRIP EDGES A MINIMUM OF 4 INCHES.
OVERLAP BLANKET 6" (MIN.) AT EACH END. OVERLAP BOTTOM END OF UPPER BLANKET OVER TOP END OF LOWER BLANKET. STAPLE ALONG OVERLAP EVERY 1.5'.
THE UPPERMOST BLANKET OF ALL SLOPE APPLICATIONS MUST START IN A CHECK SLOT. IF SLOPE LENGTH (L) IS 100' OR GREATER, INSERT BLANKET INTO A CHECK SLOT 1/3 FROM THE BOTTOM OF THE SLOPE.

REVISIONS
APPROVED: 2-28-2017
Chief Environmental Officer
CHIEF ENVIRONMENTAL OFFICER

m
MINNESOTA
DEPARTMENT OF TRANSPORTATION
Rom Jahn
STATE DESIGN ENGINEER
REVISED:
APPROVED:
2-28-2017

PERMANENT EROSION CONTROL
BLANKET STAPLE PATTERN FOR SLOPES
STANDARD PLAN 5-297.404
SP 002-678-022
SP 198-020-037
68 OF 126

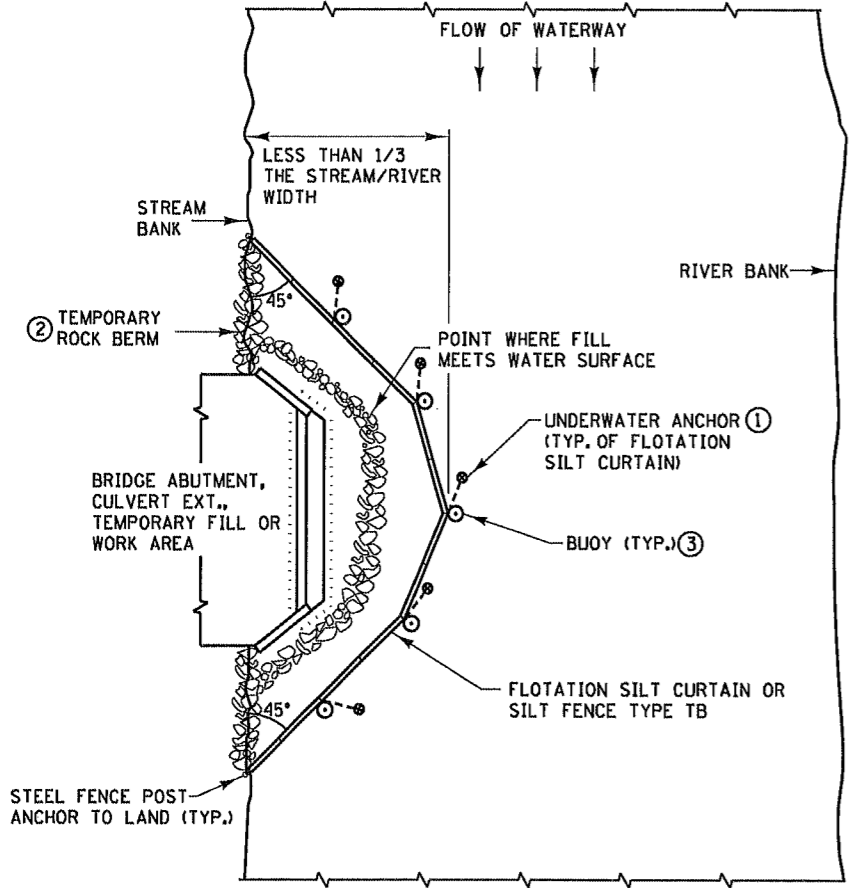

PLAN VIEW FOR STREAM ⑤

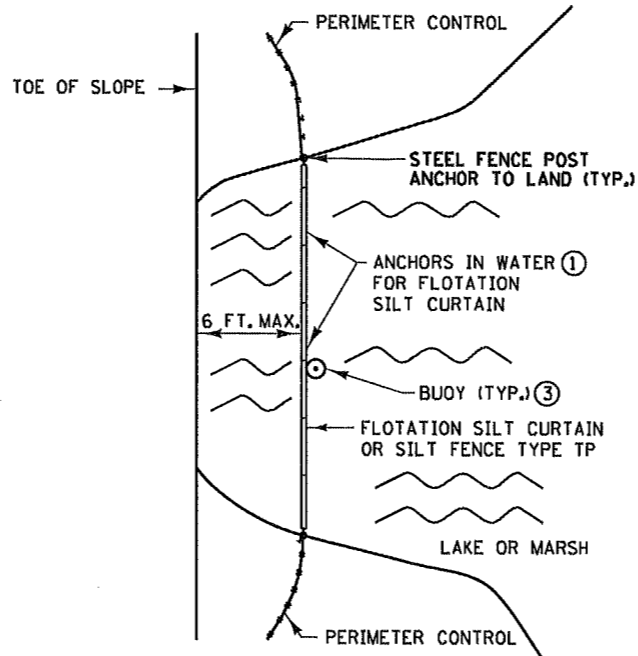

PLAN VIEW FOR LAKE OR MARSH ⑤

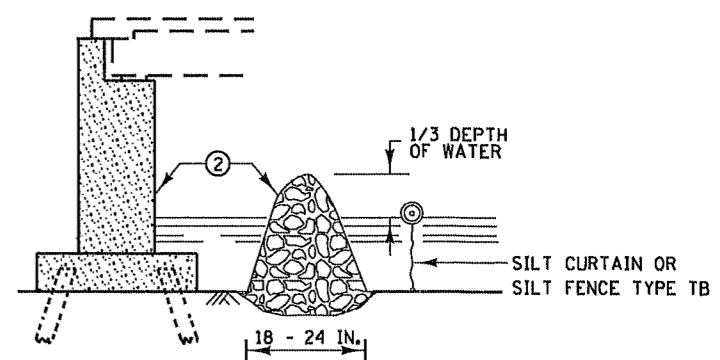

TEMPORARY ROCK BERM FOR SEDIMENT CONTROL

INSTALLATION GUIDELINES SILT FENCE TYPE TB
 MINIMUM WATER DEPTH: 1 FT.
 MAXIMUM WATER DEPTH: 3 FT.
 MAXIMUM WATER VELOCITY: 5 FT./SEC.

INSTALLATION GUIDELINES FLOTATION SILT CURTAIN TYPE: STILL WATER
 MINIMUM WATER DEPTH: 3 FT.
 MAXIMUM WATER DEPTH: 10 FT.
 MAXIMUM WATER VELOCITY: 2 FT./SEC.
 MAXIMUM WAVE HEIGHT: 1 FT.

INSTALLATION GUIDELINES FLOTATION SILT CURTAIN TYPE: MOVING WATER
 MINIMUM WATER DEPTH: 3 FT.
 MAXIMUM WATER DEPTH: 10 FT.
 MAXIMUM WATER VELOCITY: 5 FT./SEC.
 MAXIMUM WAVE HEIGHT: 2 FT.

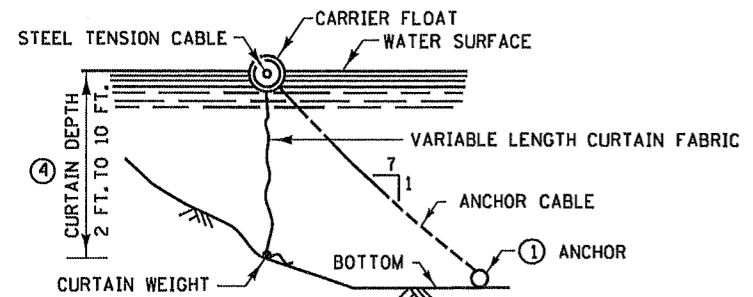

FLOTATION SILT CURTAIN

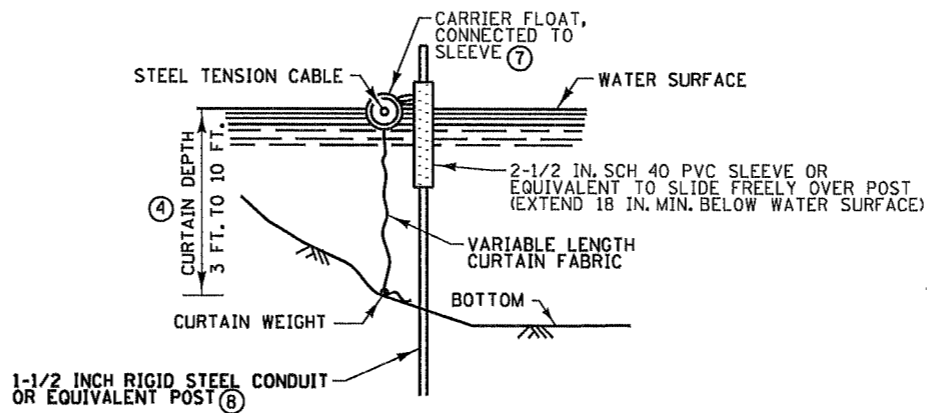

ALTERNATE FLOTATION SILT CURTAIN

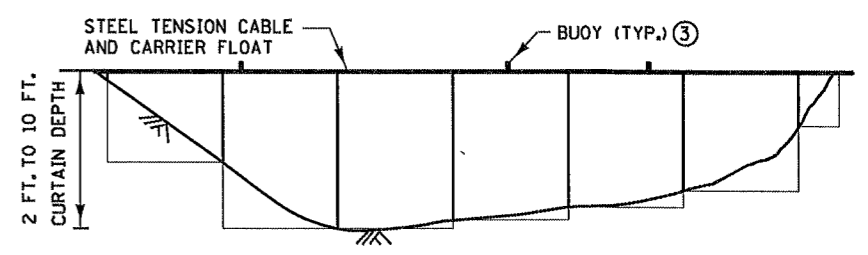

FRONT VIEW FOR FLOTATION SILT CURTAIN

NOTES:

- SEE SPECS. 2573, 3886, 3887 & 3893.
- FOR ANCHOR SPACING AND WEIGHT REQUIREMENTS, SEE SPEC. 2573.
 - IN AREAS WHERE THE PLAN CALLS FOR RIPRAP AT A BRIDGE, CULVERT, OR SLOPE, A TEMPORARY ROCK BERM CONSTRUCTED FROM THE RIPRAP CAN BE USED TO PROVIDE ADDITIONAL PROTECTION. WHEN THE WORK IS COMPLETE THE RIPRAP CAN THEN BE MOVED TO THE PERMANENT LOCATION INDICATED IN THE PLANS. THE TEMPORARY ROCK BERM IS INCIDENTAL.
 - ON U.S. COAST GUARD OR OTHER MOTORIZED WATERWAYS, BUOYS ARE REQUIRED TO MARK THE ENDS AND SPECIAL AREAS FOR VISIBILITY. PLACE BUOYS AS REQUIRED FOR NAVIGATIONAL PURPOSES.
 - MINIMUM WATER DEPTH APPLIES TO THE DEEPEST POINT ALONG THE FLOTATION SILT CURTAIN OR SILT FENCE TYPE TB FOR DETERMINING APPLICABILITY OF FLOTATION SILT CURTAIN OR SILT FENCE TYPE TB.
 - SILT CURTAIN SHOULD BE REMOVED WHEN THE AREA CONTRIBUTING DIRECT RUNOFF HAS BEEN TEMPORARILY OR PERMANENTLY STABILIZED. SILT CURTAIN SHOULD ALSO BE REMOVED BEFORE WINTER IF ICE UP OR ICE FLOW IS ANTICIPATED.
 - EMBED POST INTO BOTTOM A MINIMUM OF 40% OF THE WATER DEPTH (INCLUDING WAVE HEIGHT), BUT IN NO CASE SHALL EMBEDMENT BE LESS THAN 2 FEET.
 - ANCHOR FLOAT MUST BE CONNECTED SECURELY TO SLEEVE WITH A MINIMUM TENSILE STRENGTH OF 100 LBS. CONNECTION METHOD MUST ALLOW FOR SLEEVE TO MOVE FREELY ON POST.
 - PROVIDE SUFFICIENT NUMBER OF POST ANCHORS TO MAINTAIN SILT CURTAIN POSITION.

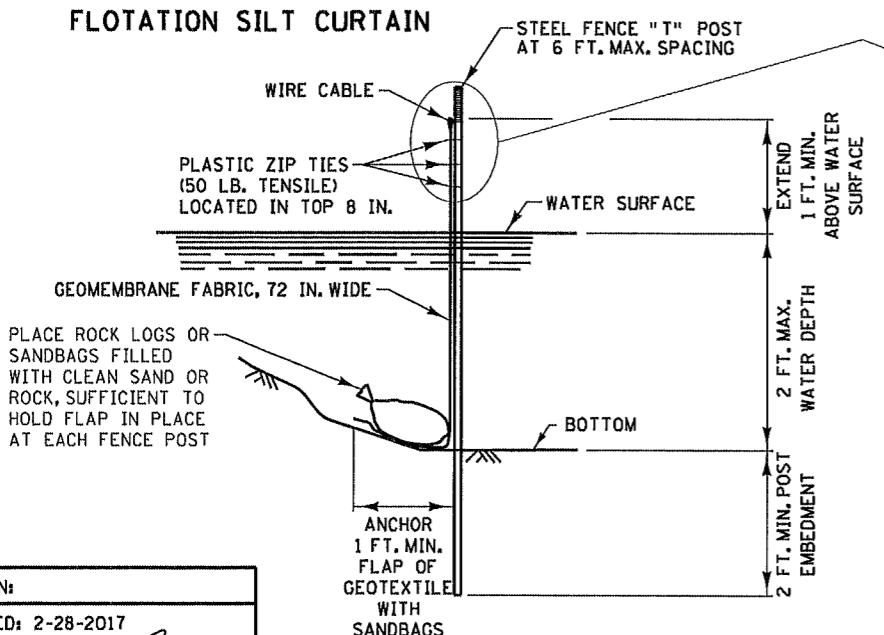

SILT FENCE TYPE TB ⑥

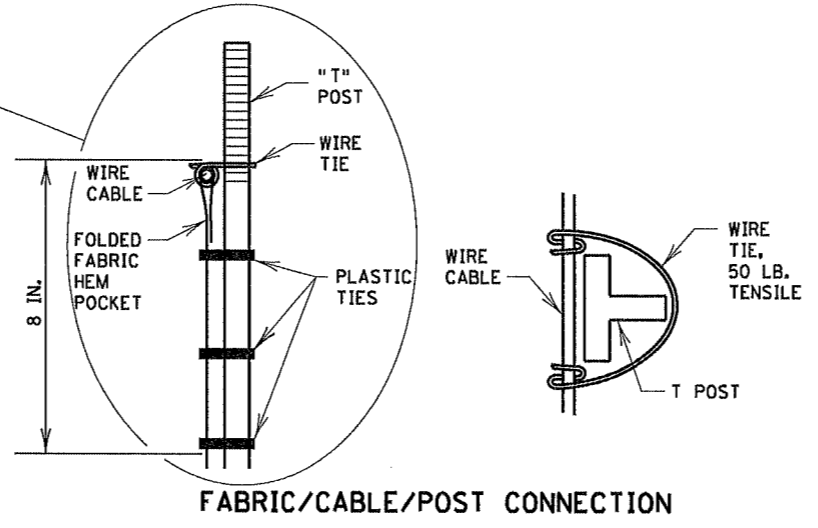

FABRIC/CABLE/POST CONNECTION

REVISION:

APPROVED: 2-28-2017

Chief Environmental Officer

MINNESOTA DEPARTMENT OF TRANSPORTATION

REVISOR:

APPROVED: 2-28-2017

STATE DESIGN ENGINEER

TEMPORARY SEDIMENT CONTROL SILT CURTAIN OR SILT FENCE TYPE TB

STANDARD PLAN 5-297.405

SP 002-678-022

SP 198-020-037

69 OF 126

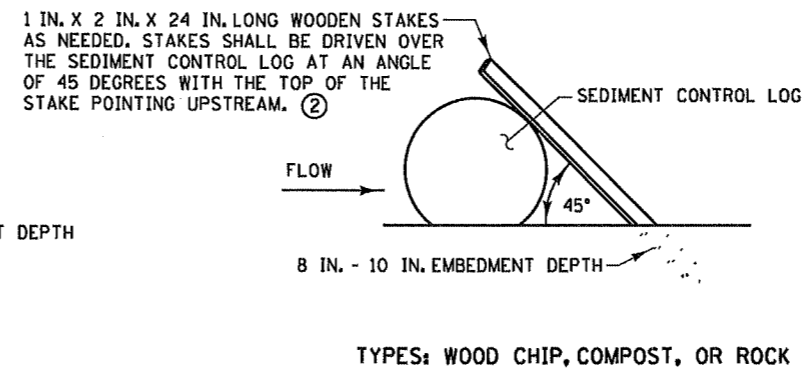
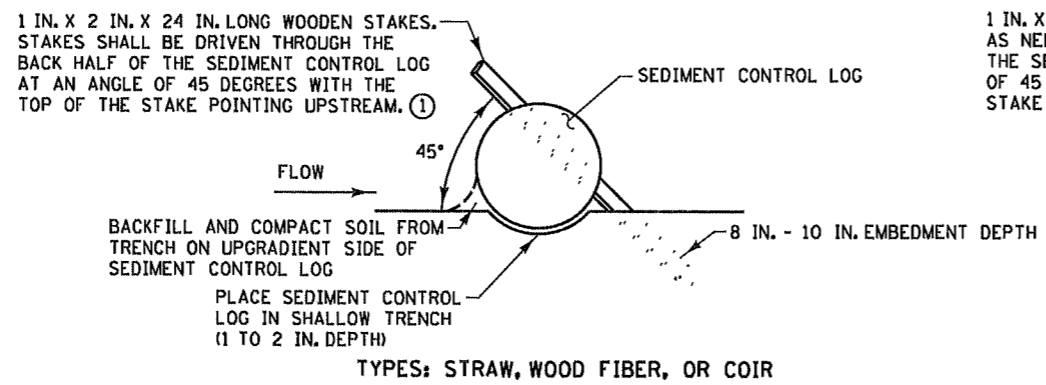

SEDIMENT CONTROL LOGS

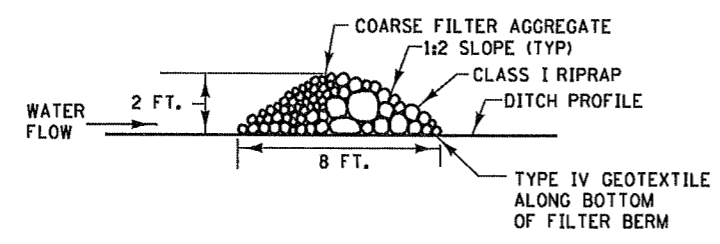

TYPE 3 (ROCK WEEPER)

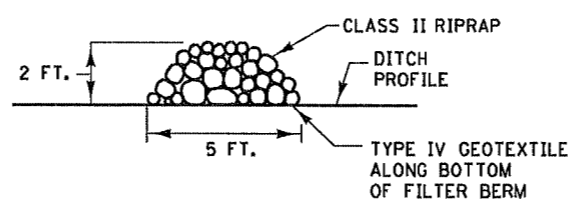

TYPE 5 (ROCK)

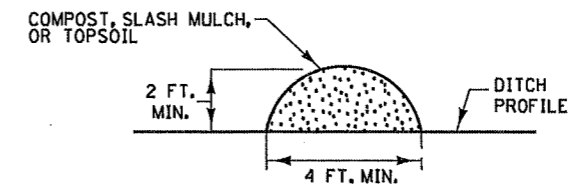

TYPE 1 (COMPOST), TYPE 2 (SLASH MULCH), OR TYPE 4 (TOPSOIL)

FILTER BERMS

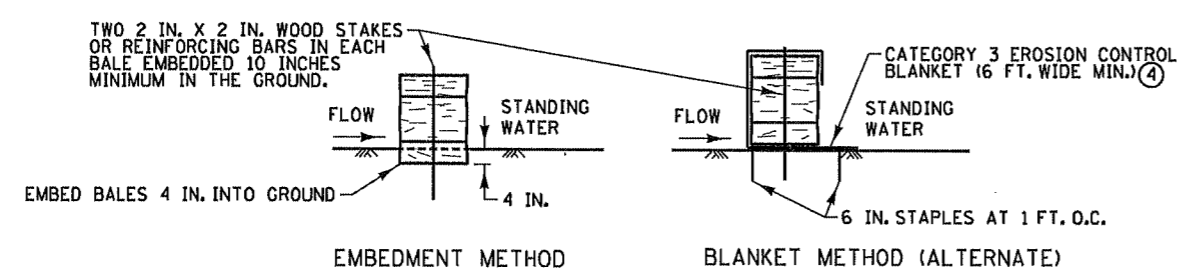

BALE BARRIERS ③

NOTES:

- SEE SPECS. 2573, 3149, 3874, 3882, 3886, & 3897.
- ① SPACE BETWEEN STAKES SHALL BE A MAXIMUM OF 1 FOOT FOR DITCH CHECKS OR 2 FEET FOR OTHER APPLICATIONS.
- ② PLACE STAKES AS NEEDED TO PREVENT MOVEMENT OF SEDIMENT CONTROL LOGS PLACED ON SLOPES OR AS NEEDED DUE TO OTHER FACTORS. STAKES SHALL BE INCIDENTAL.
- ③ TO BE USED FOR CRITICAL PERIMETER CONTROL AREAS WHERE STANDING WATER OCCURS (6 INCH MAX. DEPTH). BALES SHALL CONSIST OF TYPE 1 MULCH OF APPROXIMATELY 14 IN. X 18 IN. X 36 IN. LONG. BALES SHALL BE PLACED ON EDGE AND BUTTED TIGHT TO ADJACENT BALES.
- ④ INSTEAD OF TRENCHING, PLACE BALE ON THE BLANKET AND WRAP BLANKET AROUND THE BALE. PLACE STAKE THROUGH BALE AND BLANKET.

REVISION:

APPROVED: 2-28-2017

Chief Environmental Officer

CHIEF ENVIRONMENTAL OFFICER

REVISOR:

APPROVED: 2-28-2017

STATE DESIGN ENGINEER

TEMPORARY SEDIMENT CONTROL

FILTER BERMS, SEDIMENT CONTROL LOGS, AND BALE BARRIERS

STANDARD PLAN 5-297.405

SP 002-678-022

SP 198-020-037

70 OF 126

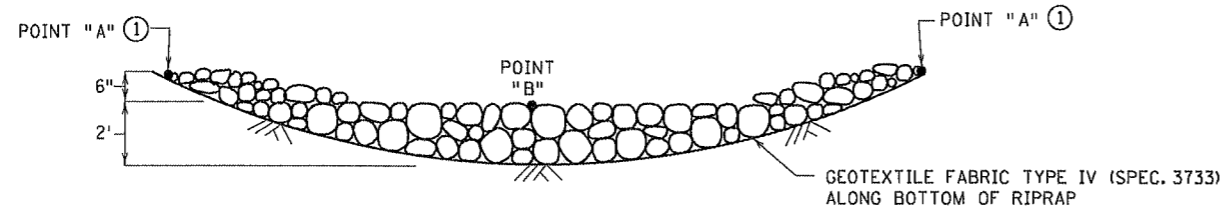

ROCK DITCH CHECKS
FILTER BERMS TYPE 3 (ROCK WEEPER) OR FILTER TYPE 5 (ROCK) ②③
 (FOR USE ON ROUGH GRADED AREAS)

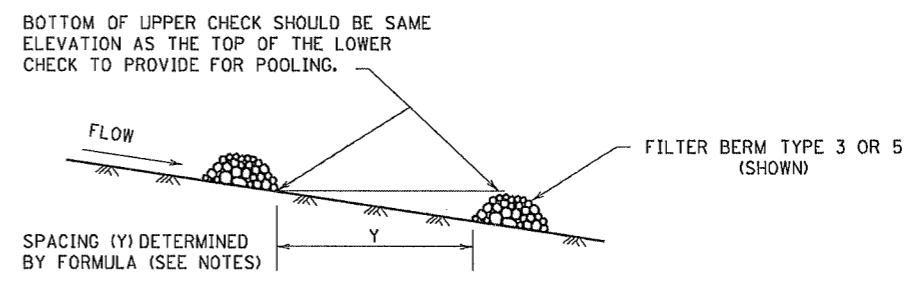

DITCH CHECK SPACING
 (FOR ALL FILTER BERM TYPES)

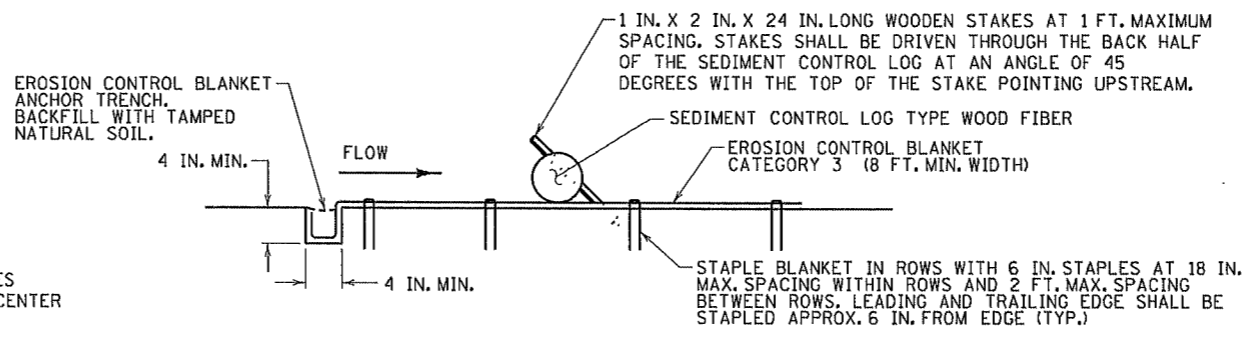
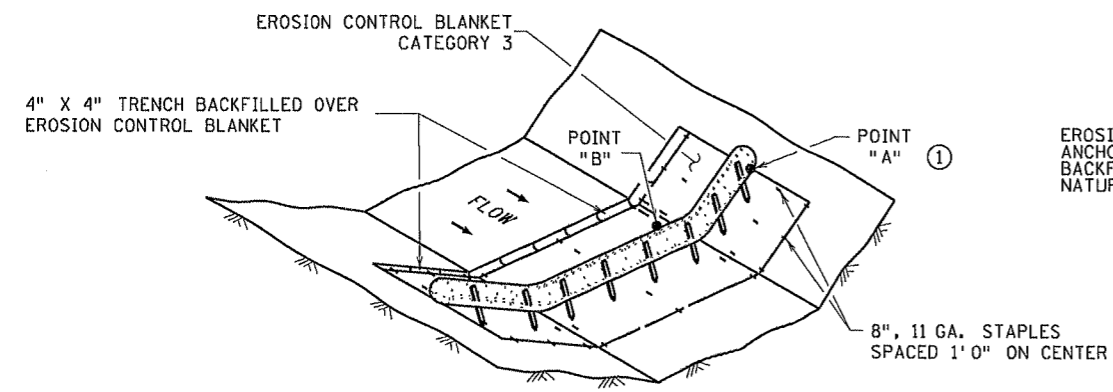

SEDIMENT CONTROL LOG TYPE BLANKET SYSTEM ④

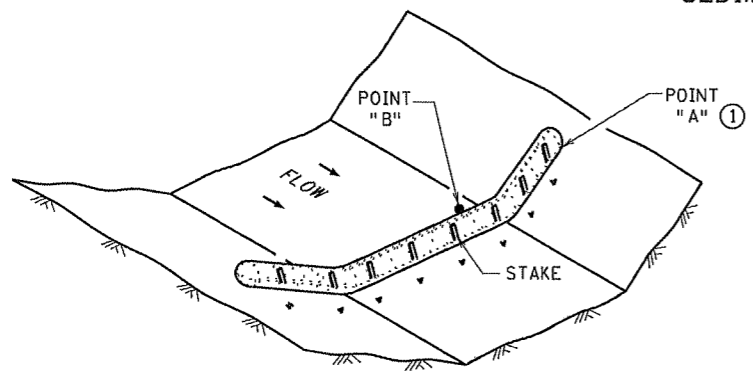

SEDIMENT CONTROL LOG TYPE WOOD FIBER, OR TYPE COMPOST ⑤
 (FOR USE ON ROUGH GRADED AREAS)

- NOTES:**
- SEE SPECS. 2573, 3601, 3733, 3885, 3886 & 3889.
 - FOR DITCH CHECKS, PLACE SEDIMENT CONTROL LOG PERPENDICULAR TO FLOW AND IN A CRESCENT SHAPE WITH THE ENDS FACING UPSTREAM.
 - APPROXIMATE SPACING BETWEEN EACH DITCH CHECK SHOULD BE DETERMINED FROM THE FOLLOWING SPACING FORMULA:
- $$\text{APPROXIMATE SPACING OF DITCH CHECKS (FT.)} = Y = \frac{\text{DITCH CHECK HEIGHT (FT)}}{\% \text{ CHANNEL SLOPE}} \times 100$$
- ① POINT "A" MUST BE A MINIMUM OF 6 INCHES HIGHER THAN POINT "B" TO ENSURE THAT WATER FLOWS OVER THE DIKE AND NOT AROUND THE ENDS.
 - ② PERMANENT ROCK DITCH CHECKS PLACED WITHIN THE CLEAR ZONE ARE TO BE 18" OR LESS IN HEIGHT. A 1:6 APPROACH AND DEPARTURE SLOPE SHALL BE PROVIDED.
 - ③ DITCH GRADE 3% - 5%, MAX. FLOW VELOCITY 12 FT./SEC..
 - ④ DITCH GRADE 1.5% - 3%, MAX. FLOW VELOCITY 4.5 FT./SEC..
 - ⑤ DITCH GRADE 1.5% - 3%, MAX. FLOW VELOCITY 1.5 FT./SEC..

REVISION:
 APPROVED: 2-28-2017
[Signature]
 CHIEF ENVIRONMENTAL OFFICER

m
 MINNESOTA
 DEPARTMENT
 OF
 TRANSPORTATION

REVISOR:
[Signature]
 STATE DESIGN ENGINEER

APPROVED:
 2-28-2017

TEMPORARY SEDIMENT CONTROL
 DITCH CHECK

STANDARD PLAN 5-297.405

SP 002-678-022
 SP 198-020-037

71 OF 126

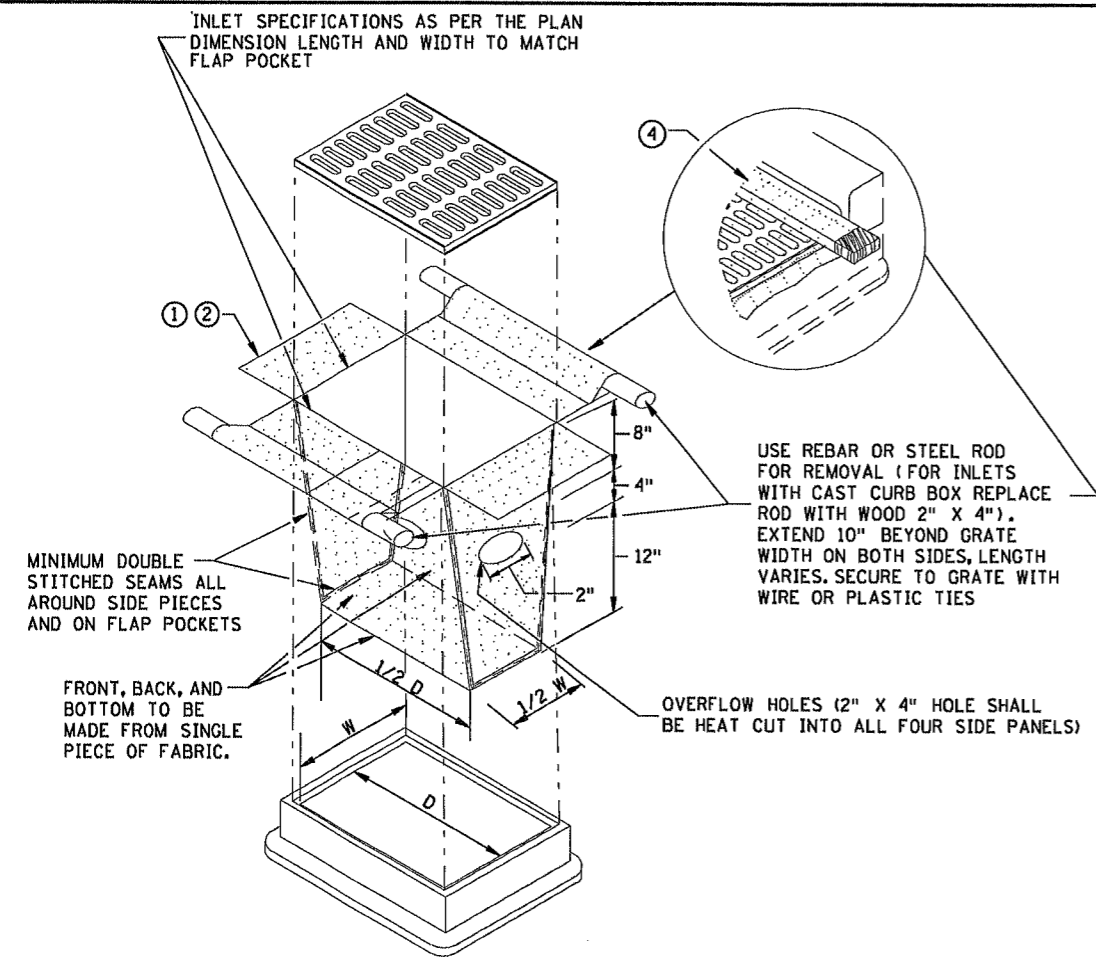

FILTER BAG INSERT ③

(CAN BE INSTALLED IN ANY INLET TYPE WITH OR WITHOUT A CURB BOX)

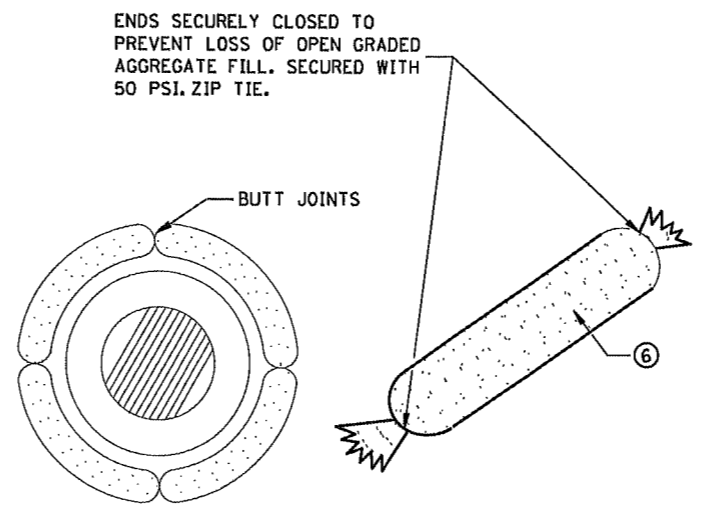

ROCK LOG/COMPOST LOG

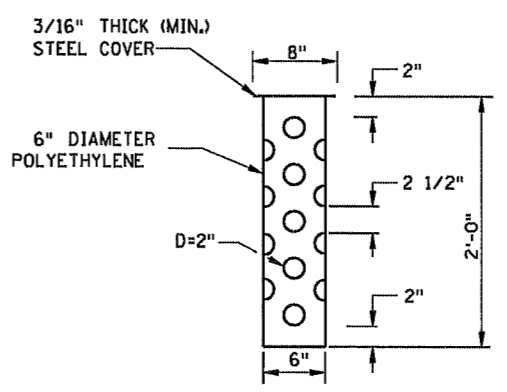

TUBE RISER

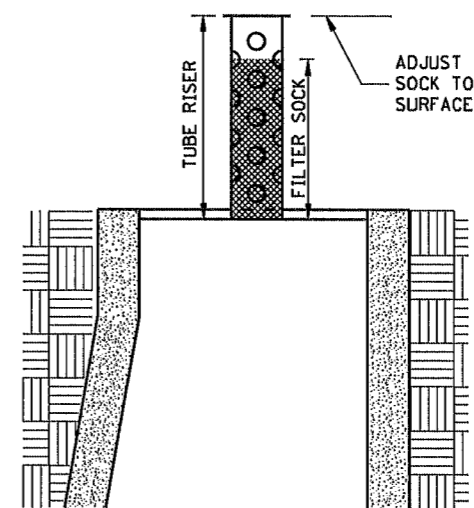

SECTION (UP POSITION)

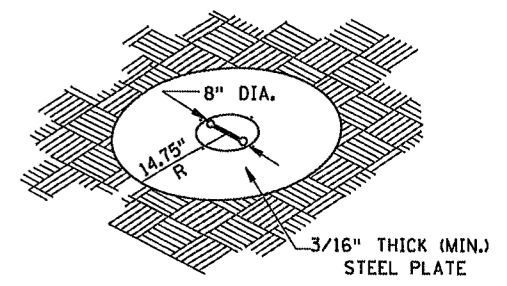

PERSPECTIVE VIEW

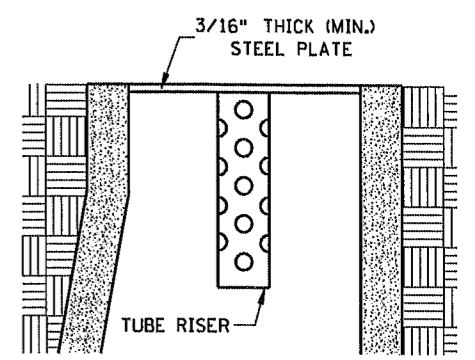

SECTION (DOWN POSITION)

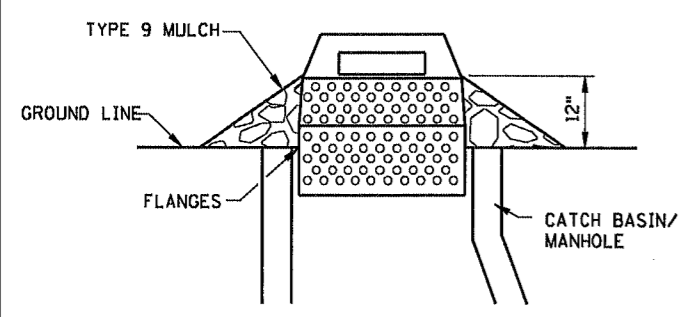

SEDIMENT CONTROL INLET HAT

NOTE:
THE SEDIMENT CONTROL BARRIER SHALL BE A METAL OR PLASTIC/POLYETHYLENE RISER SIZED TO FIT INSIDE THE CATCH BASIN/MANHOLE; HAVE PERFORATIONS TO ALLOW FOR WATER INFILTRATION; HAVE AN OVERFLOW OPENING, FLANGES AND A LID/COVER.

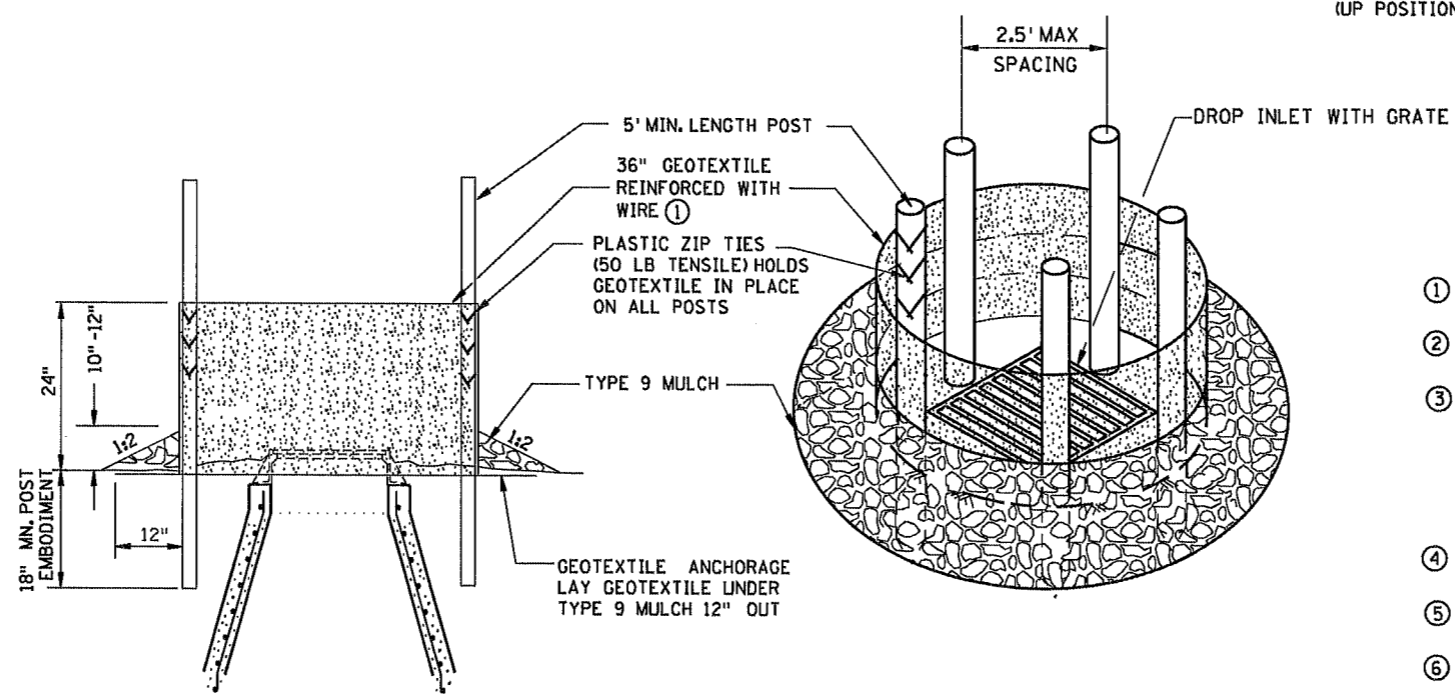

SILT FENCE RING AND ROCK FILTER BERM

USE WHERE INLET DRAINS IN AN AREA WITH SLOPES AT 1:3 OR LESS

POP-UP HEAD

NOTES:

- SEE SPECS. 2573, 3137, & 3886.
- DEVICES MUST BE ADJUSTED ACCORDINGLY AS TO NOT CAUSE FLOODING ON ROADWAY THAT WOULD IMPEED TRAFFIC FLOW.
- ① ALL GEOTEXTILE USED FOR INLET PROTECTION SHALL BE MONOFILAMENT IN BOTH DIRECTIONS, MEETING SPEC. 3886.
- ② FINISHED SIZE, INCLUDING POCKETS WHERE REQUIRED SHALL EXTEND A MINIMUM OF 10 INCHES AROUND THE PERIMETER TO FACILITATE MAINTENANCE OR REMOVAL.
- ③ INSTALLATION NOTES:
DO NOT PLACE FILTER BAG INSERT IN INLETS SHALLOWER THAN 30 INCHES, MEASURED FROM THE BOTTOM OF THE INLET TO THE TOP OF THE GRATE. THE PLACED BAG SHALL HAVE A MINIMUM SIDE CLEARANCE OF 3 INCHES BETWEEN THE INLET WALLS AND THE BAG, MEASURED AT THE BOTTOM OF THE OVERFLOW HOLES. WHERE NECESSARY THE CONTRACTOR SHALL CLINCH THE BAG, USING PLASTIC ZIP TIES, TO ACHIEVE THE 3 INCH SIDE CLEARANCE.
- ④ FLAP POCKETS SHALL BE LARGE ENOUGH TO ACCEPT WOOD 2 INCH X 4 INCH OR USE A ROCK SOCK OR SAND BAGS IN PLACE OF THE FLAP POCKETS.
- ⑤ SOCK HEIGHT MUST NOT BE SO HIGH AS TO SLOW DOWN WATER FILTRATION TO CAUSE FLOODING OF THE ROADWAY.
- ⑥ GEOTEXTILE SOCK BETWEEN 4-10 FEET LONG AND 4-6 INCH DIAMETER. SEAM TO BE JOINED BY TWO ROWS OF STITCHING WITH A PLASTIC MESH BACKING OR PROVIDE A HEAT BONDED SEAM (OR APPROVED EQUIVALENT). FILL ROCK LOG WITH OPEN GRADED AGGREGATE CONSISTING OF SOUND DURABLE PARTICLES OF COARSE AGGREGATE CONFORMING TO SPEC. 3137 TABLE 3137-1; CA-3 GRADATION.

REVISION:
APPROVED: 2-28-2017
Chris Elvick
CHIEF ENVIRONMENTAL OFFICER

m
MINNESOTA
DEPARTMENT
OF
TRANSPORTATION

Tom Ska...
STATE DESIGN ENGINEER

REVISED:
APPROVED:
2-28-2017

TEMPORARY SEDIMENT CONTROL
STORM DRAIN INLET PROTECTION
STANDARD PLAN 5-297.405
SP 002-678-022
SP 198-020-037
72 OF 126

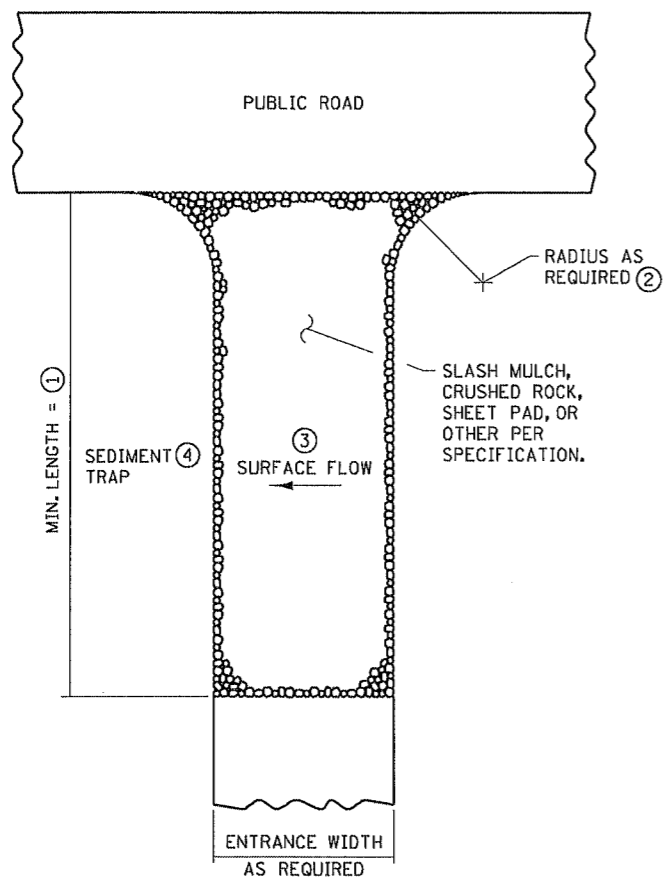

SLASH MULCH, CRUSHED ROCK, OR SHEET PAD CONSTRUCTION EXIT ⑤⑦

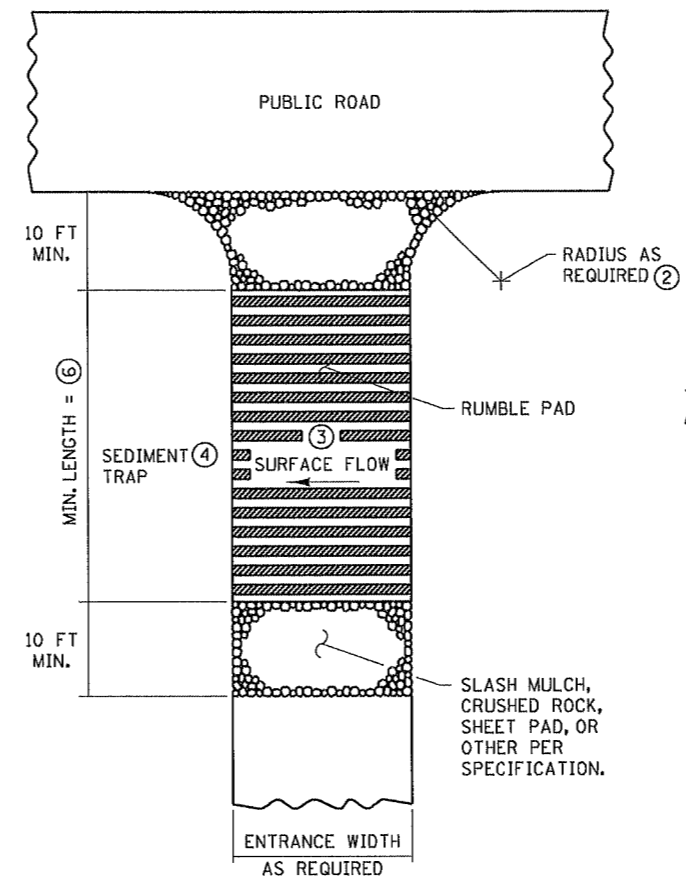

RUMBLE PAD CONSTRUCTION EXIT ⑤⑦

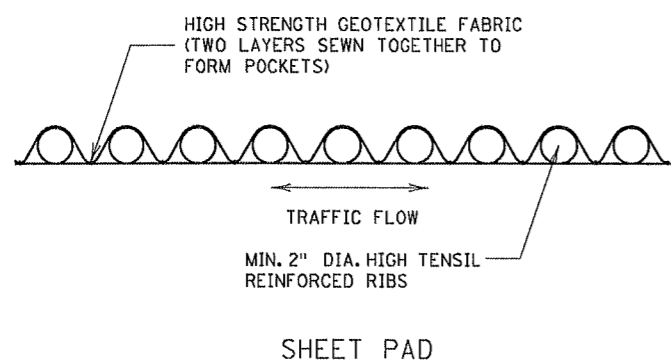
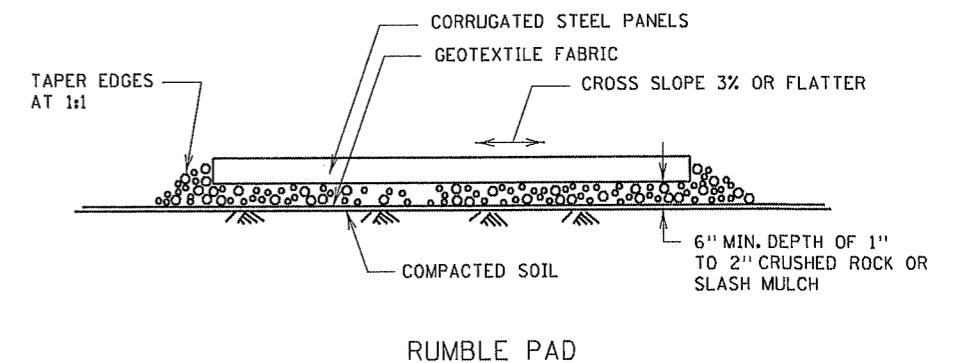

SHEET PAD

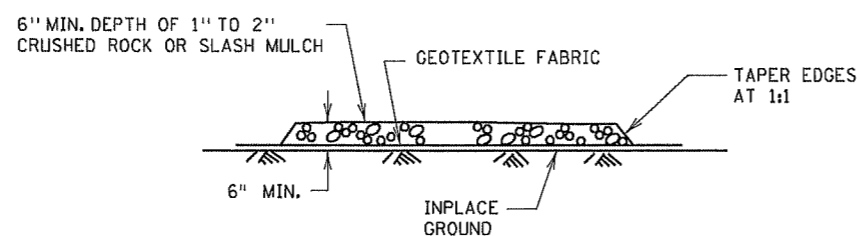

SLASH MULCH OR CRUSHED ROCK

NOTES:

SEE SPECS. 2573 & 3882.

- ① MINIMUM LENGTH SHALL BE THE GREATER OF 50 FEET OR A LENGTH SUFFICIENT TO ALLOW A MINIMUM OF 5 TIRE ROTATIONS ON THE PROVIDED PAD. MINIMUM LENGTH SHALL BE CALCULATED USING THE LARGEST TIRE WHICH WILL BE USED IN TYPICAL OPERATIONS.
- ② PROVIDE RADIUS OR WIDEN PAD SUFFICIENTLY TO PREVENT VEHICLE TIRES FROM TRACKING OFF OF PAD WHEN LEAVING SITE.
- ③ IF RUNOFF FROM DISTURBED AREAS FLOWS TOWARD CONSTRUCTION EXITS, PREVENT RUNOFF FROM DRAINING DIRECTLY TO PUBLIC ROAD OVER CONSTRUCTION EXIT BY CROWNING THE EXIT OR SLOPING TO ONE SIDE. IF SURFACE GRADING IS INSUFFICIENT, PROVIDE OTHER MEANS OF INTERCEPTING RUNOFF.
- ④ IF RUNOFF FROM CONSTRUCTION EXITS WILL DRAIN OFF OF PROJECT SITE, PROVIDE SEDIMENT TRAP WITH STABILIZED OVERFLOW.
- ⑤ IF A TIRE WASH OFF IS REQUIRED THE CONSTRUCTION EXITS SHALL BE GRADED TO DRAIN THE WASH WATER TO A SEDIMENT TRAP.
- ⑥ MINIMUM LENGTH OF RUMBLE PAD SHALL BE 20 FEET, OR AS REQUIRED TO REMOVE SEDIMENT FROM TIRES. IF SIGNIFICANT SEDIMENT IS TRACKED FROM THE SITE, THE RUMBLE PAD SHALL BE LENGTHENED OR THE DESIGN MODIFIED TO PROVIDE ADDITIONAL VIBRATION. WASH-OFF LENGTH SHALL BE AS REQUIRED TO EFFECTIVELY REMOVE CONSTRUCTION SEDIMENT FROM VEHICLE TIRES.
- ⑦ MAINTENANCE OF CONSTRUCTION EXITS SHALL OCCUR WHEN THE EFFECTIVENESS OF SEDIMENT REMOVAL HAS BEEN REDUCED. MAINTENANCE SHALL CONSIST OF REMOVING SEDIMENT AND CLEANING THE MATERIALS OR PLACING ADDITIONAL MATERIAL (SLASH MULCH OR CRUSHED ROCK) OVER SEDIMENT FILLED MATERIAL TO RESTORE EFFECTIVENESS.

REVISIONS:
 APPROVED: 2-28-2017

 CHIEF ENVIRONMENTAL OFFICER

MINNESOTA
 DEPARTMENT
 OF
 TRANSPORTATION

REVISED:

 APPROVED:
 2-28-2017
 STATE DESIGN ENGINEER

TEMPORARY SEDIMENT CONTROL
 STABILIZED CONSTRUCTION EXIT
STANDARD PLAN 5-297.405
 SP 002-678-022
 SP 198-020-037

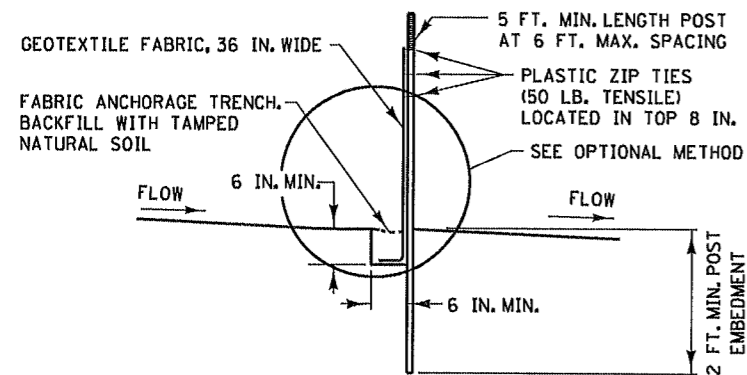

**SILTS FENCE TYPE HI ②
(HAND INSTALLED)**

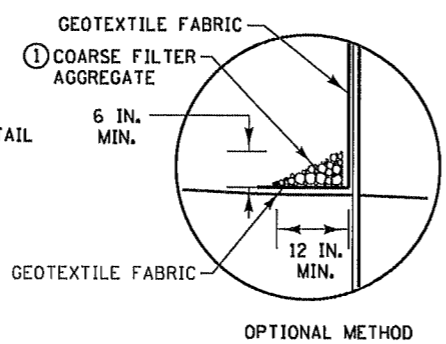

OPTIONAL METHOD

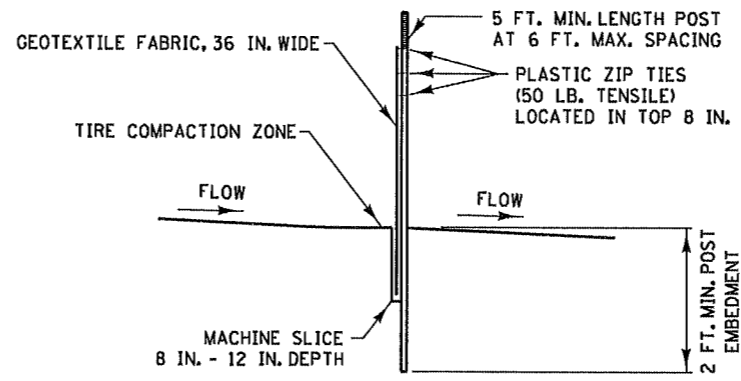

**SILTS FENCE TYPE MS ②
(MACHINE SLICED)**

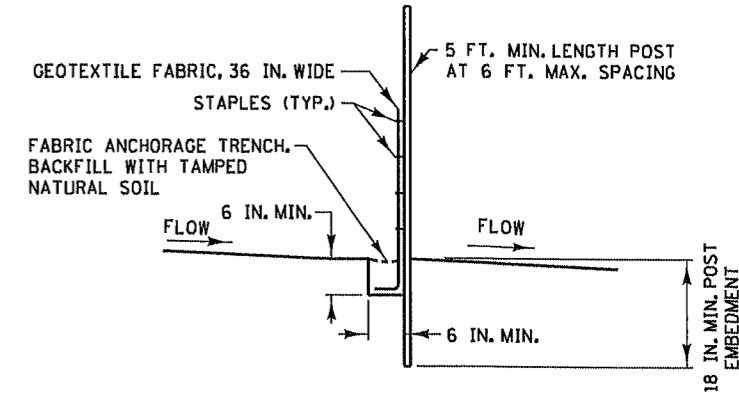

**SILTS FENCE TYPE PA ③
(PREASSEMBLED)**

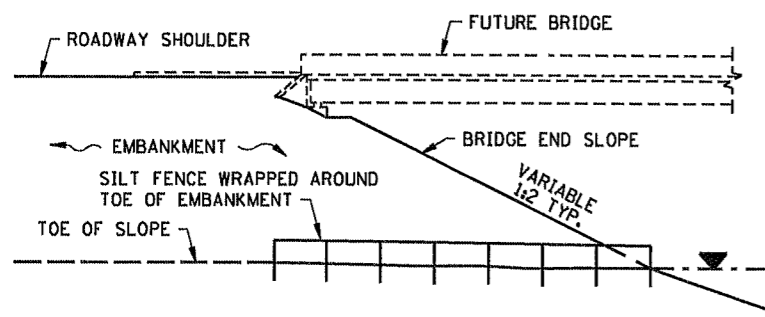

SILTS FENCE ONLY ④

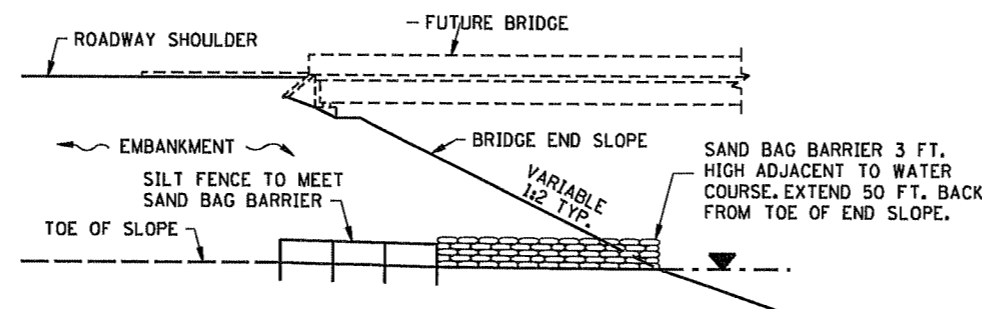

SILTS FENCE WITH SAND BAGS ⑤

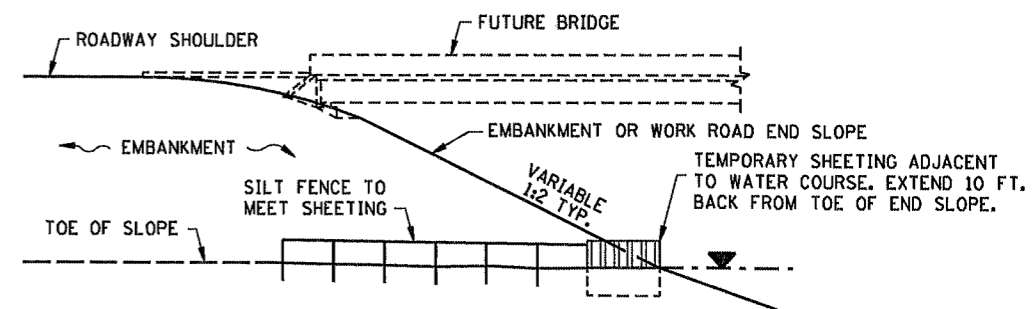

SILTS FENCE WITH SHEETING ⑥

INSTALLATION AT BRIDGE EMBANKMENT ADJACENT TO WATER

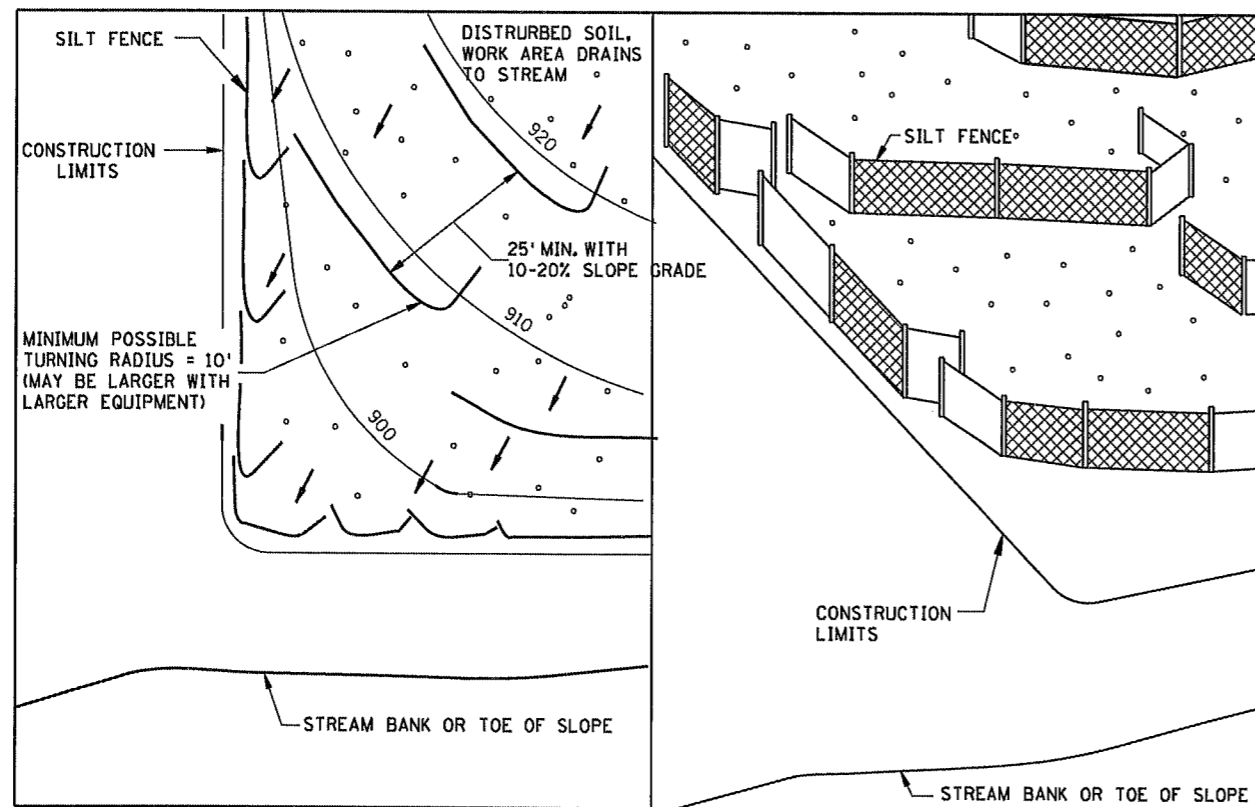

PLAN VIEW

PERSPECTIVE VIEW

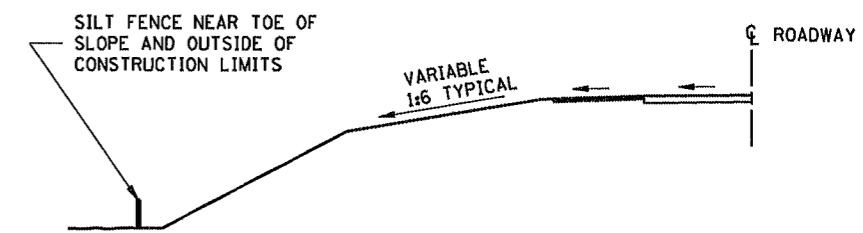

LOCATION AT TOE OF ROADWAY EMBANKMENT

- NOTES:**
 SEE SPECS. 2573, 3149 & 3886.
 ① COARSE FILTER AGGREGATE (SPEC. 3149) SHALL BE INCIDENTAL.
 ② TO PROTECT AREAS FROM SHEET FLOW, MAXIMUM CONTRIBUTING AREA: 1 ACRE.
 ③ TO PROTECT AREAS FROM SHEET FLOW, MAXIMUM CONTRIBUTING AREA: 0.25 ACRE.
 ④ WATER COURSE FLOW VELOCITY: STANDING. CONTRIBUTING SLOPE AREA: 1/2 ACRE.
 ⑤ WATER COURSE FLOW VELOCITY: 1 TO 7 FT./SEC. CONTRIBUTING SLOPE AREA: 1 ACRE.
 ⑥ WATER COURSE FLOW VELOCITY: 8 TO 15 FT./SEC. CONTRIBUTING SLOPE AREA: 3 ACRES.

REVISION:
 APPROVED: 2-28-2017
 Chief Environmental Officer

J-HOOK INSTALLATION

mn
 MINNESOTA
 DEPARTMENT
 OF
 TRANSPORTATION

Tom [Signature]
 STATE DESIGN ENGINEER

REVISED:
 APPROVED:
 2-28-2017

TEMPORARY SEDIMENT CONTROL
 SILTS FENCE
STANDARD PLAN 5-297.405
 SP 002-678-022
 SP 198-020-037
 74 OF 126

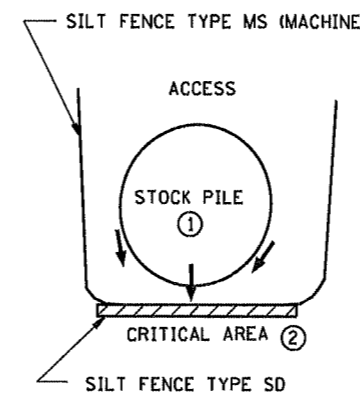
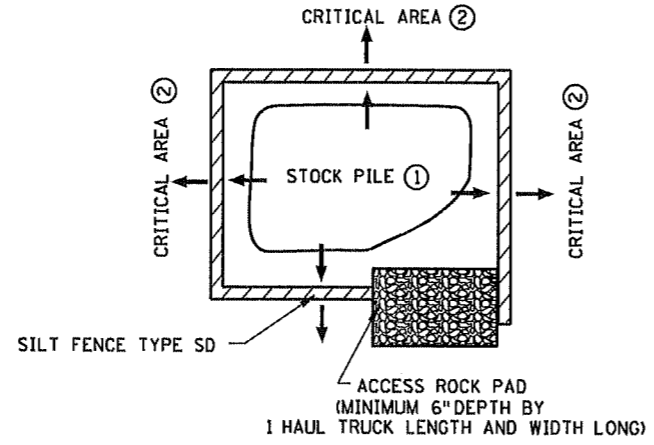
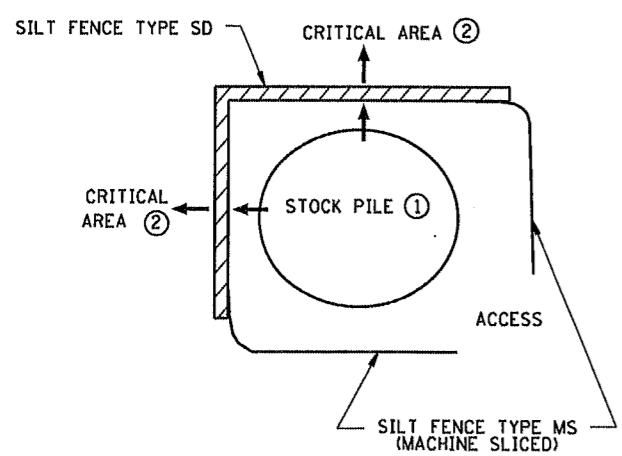

STOCK PILE CONTAINMENT

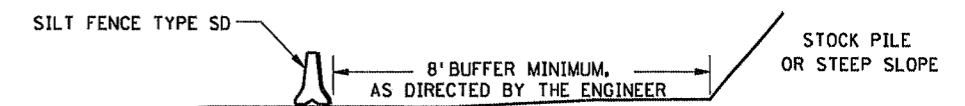

STOCKPILE SEDIMENT CONTROL

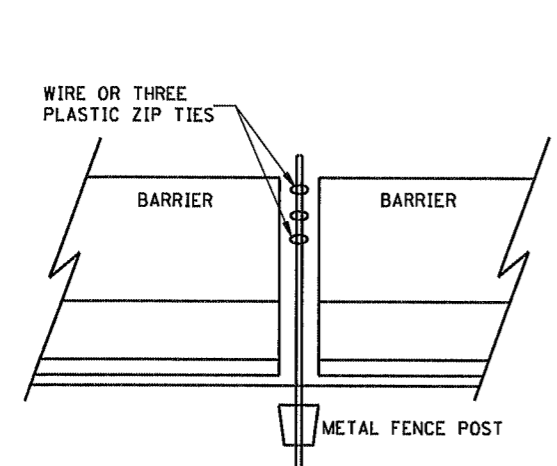

PROFILE VIEW

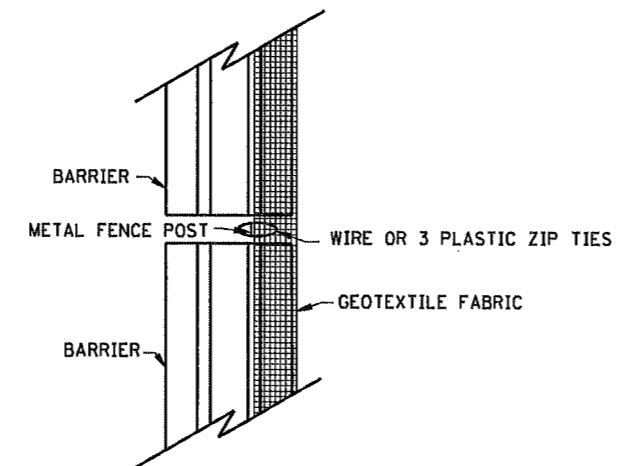

TOP VIEW

SILT FENCE TYPE SD (SUPER DUTY) BARRIER WITHOUT LOOP BARS

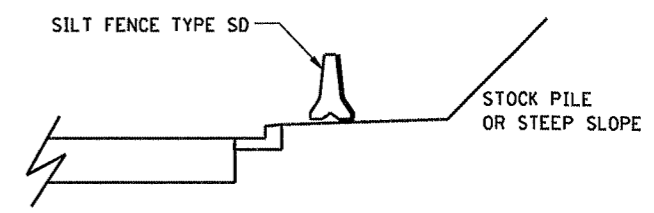

CURB AND GUTTER PROTECTION SYSTEM

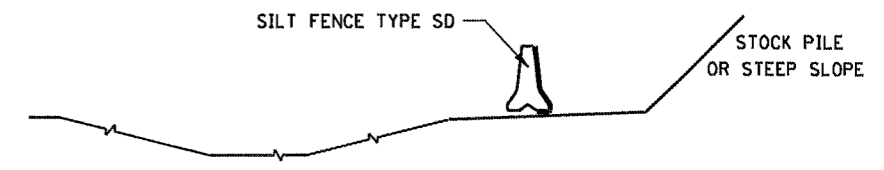

DITCH PROTECTION SYSTEM

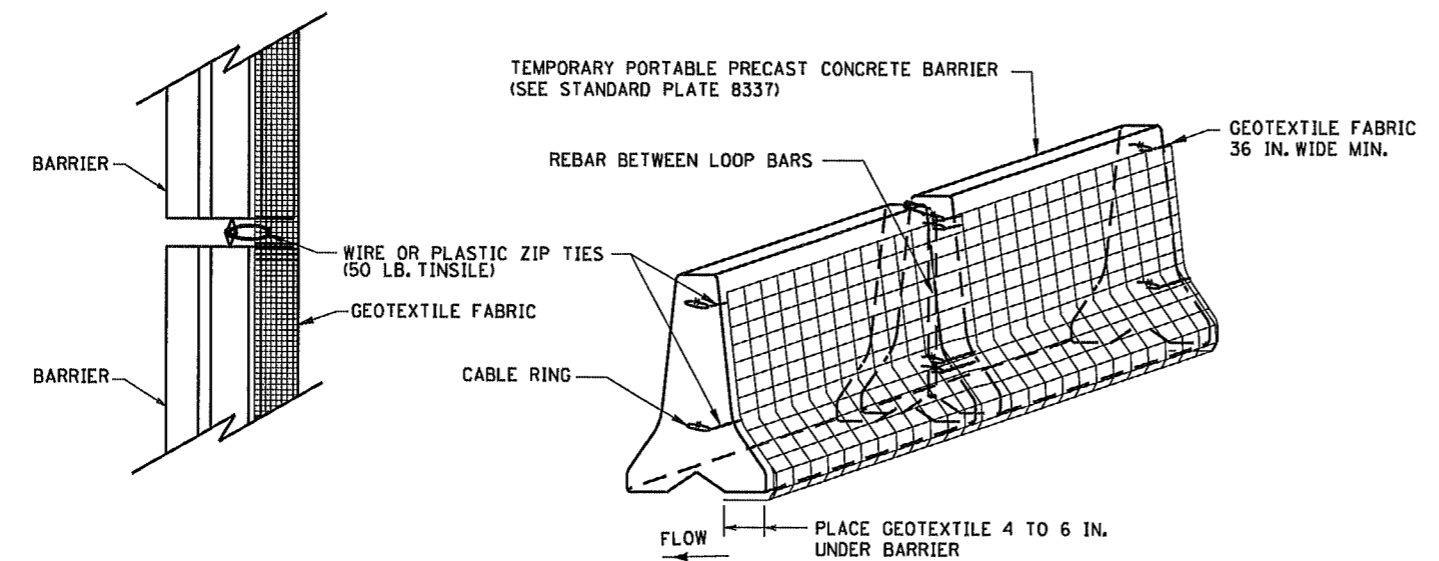

TOP VIEW

PERSPECTIVE VIEW

SILT FENCE TYPE SD (SUPER DUTY) BARRIER WITH LOOP BARS

NOTES:

- SEE SPECS. 2533, 2573 & 3886.
- SILT FENCE TYPE SD USED TO PROTECT CRITICAL AREAS FROM SHEET FLOW, AND AREAS WHERE OTHER SILT FENCES CANNOT BE PLACED. MAXIMUM CONTRIBUTING AREA: 1 ACRE.
- PLACE SILT FENCE TYPE SD ALONG A CONSTANT ELEVATION.
- SILT FENCE TYPE SD CAN UTILIZE EITHER A CONCRETE, OR WATER FILLED, TEMPORARY MEDIAN BARRIER.
- ① PLACING STOCK PILES NEXT TO AN ENVIRONMENTALLY SENSITIVE AREA IS NOT RECOMMENDED. WHEN THERE ARE NO FEASIBLE ALTERNATIVES, PLACE SILT FENCE SD AS SHOWN OR AS DIRECTED BY THE ENGINEER.
- ② CRITICAL AREAS INCLUDE WETLANDS, JUDICIAL DITCHES, STREAMS, WATER BODIES, AND OTHER AREAS REQUIRING PROTECTION.

REVISION:
 APPROVED: 2-28-2017
Chief Environmental Officer
 CHIEF ENVIRONMENTAL OFFICER

m
 MINNESOTA
 DEPARTMENT
 OF
 TRANSPORTATION

Tom S...
 STATE DESIGN ENGINEER

REVISED:
 APPROVED:
 2-28-2017

TEMPORARY SEDIMENT CONTROL
 SUPER DUTY SILT FENCE
STANDARD PLAN 5-297.405
 SP 002-678-022
 SP 198-020-037

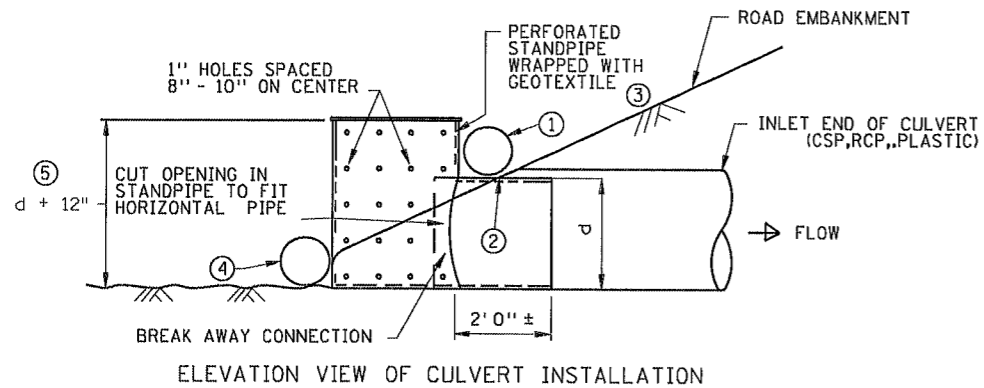
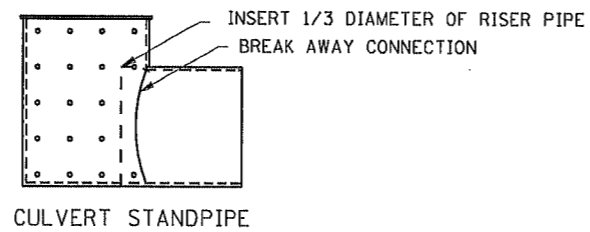
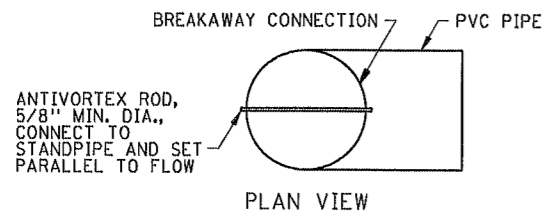

CULVERT STANDPIPE INSERT (D-RISER)

d = CULVERT SIZE: 12" - 36"

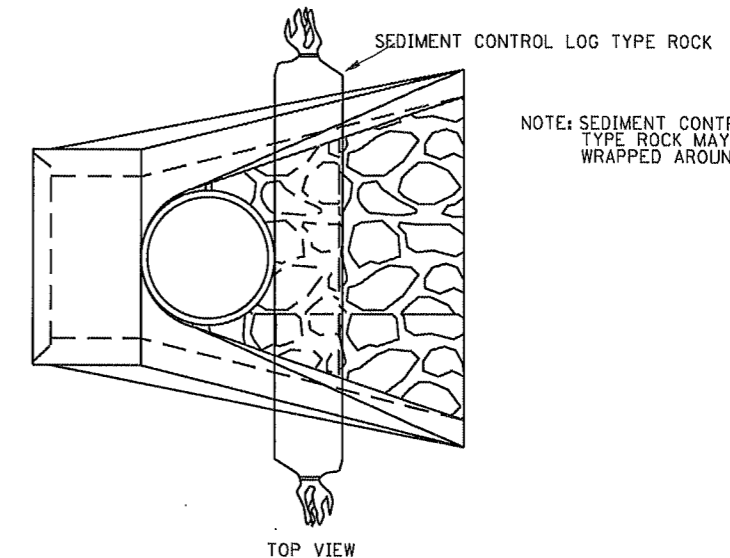
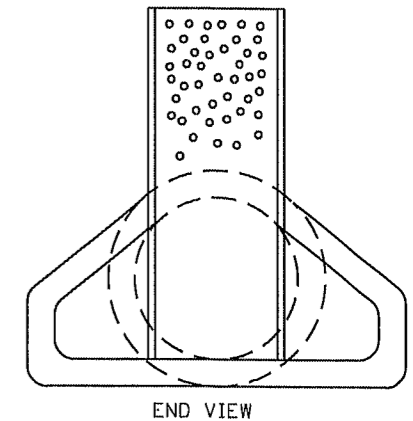
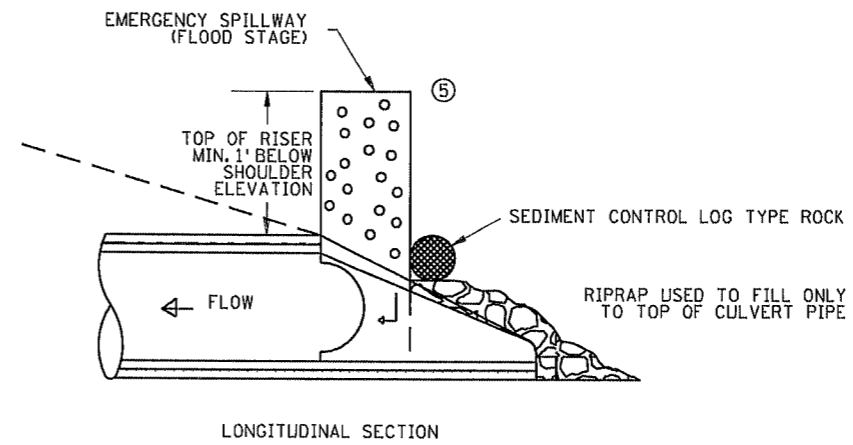

CULVERT STANDPIPE INSERT (D-RISER)

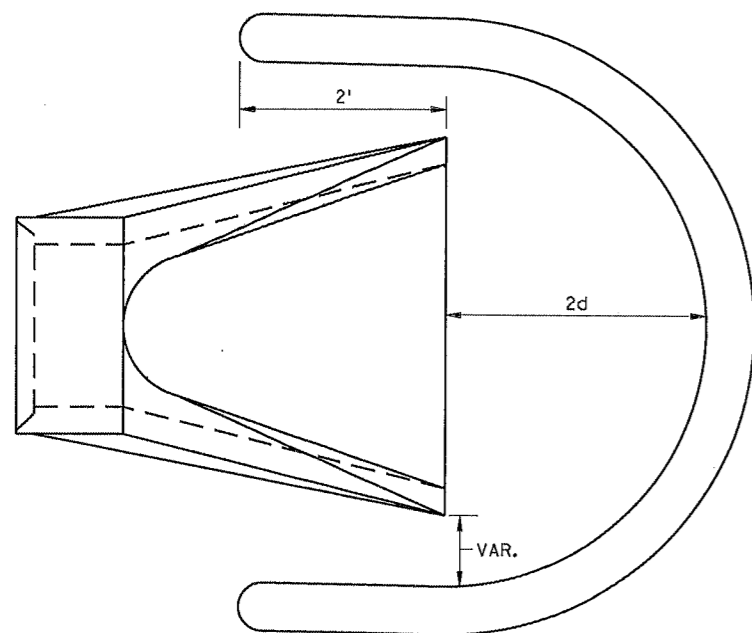

SEDIMENT CONTROL LOG WEIR
(COMPOST, WOOD CHIP, OR ROCK)

d = CULVERT SIZE: 12" - 36"

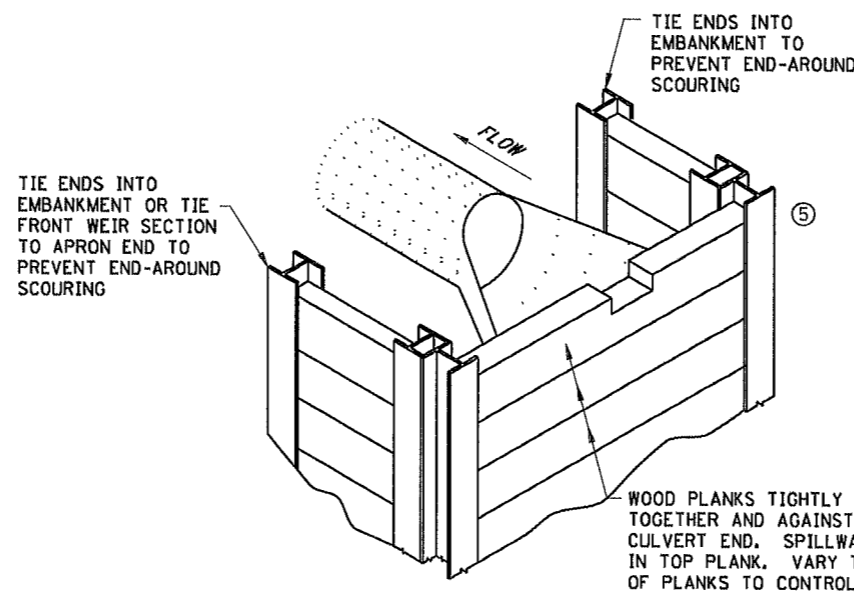

WOOD PLANK WEIR

NOTES:

- SEE SPECS. 2573, 3891 & 3893.
- FOR USE WHEN TEMPORARY PONDING IS NEEDED IN DITCH SECTIONS FOR SEDIMENT CONTROL.
- MANUFACTURED ALTERNATIVES LISTED ON MNDOT'S APPROVED PRODUCTS LIST MAY BE SUBSTITUTED AT NO ADDITIONAL COST.
- ① ROCK LOG OR SANDBAG TO HOLD STANDPIPE AND ACT AS A SEAL BETWEEN RISER PIPE AND CULVERT.
- ② PLACE CULVERT APRON AND SLIDE TEMPORARY STANDPIPE INTO CSP OR RCP CULVERT.
- ③ ALL GEOTEXTILE USED FOR CULVERT PROTECTION SHALL BE MONOFILAMENT IN BOTH DIRECTIONS, MEETING SPEC. 3886 FOR MACHINE SLICED.
- ④ ROCK LOG OR RIP RAP TO HOLD STANDPIPE AND ACT AS A FILTER BETWEEN RISER PIPE AND CULVERT.
- ⑤ HEIGHT OVERFLOW NOT TO CAUSE FLOODING OF ROAD OR ADJACENT PROPERTIES.

REVISION:
APPROVED: 2-28-2017
[Signature]
CHIEF ENVIRONMENTAL OFFICER

m
MINNESOTA
DEPARTMENT
OF
TRANSPORTATION

[Signature]
STATE DESIGN ENGINEER

REVISED:
APPROVED:
2-28-2017

TEMPORARY SEDIMENT CONTROL
CULVERT END CONTROLS
STANDARD PLAN 5-297.405
SP 002-678-022
SP 198-020-037

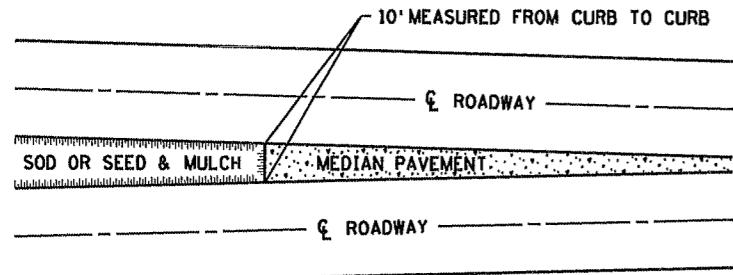

SODDING LIMITS AT GORE AREA

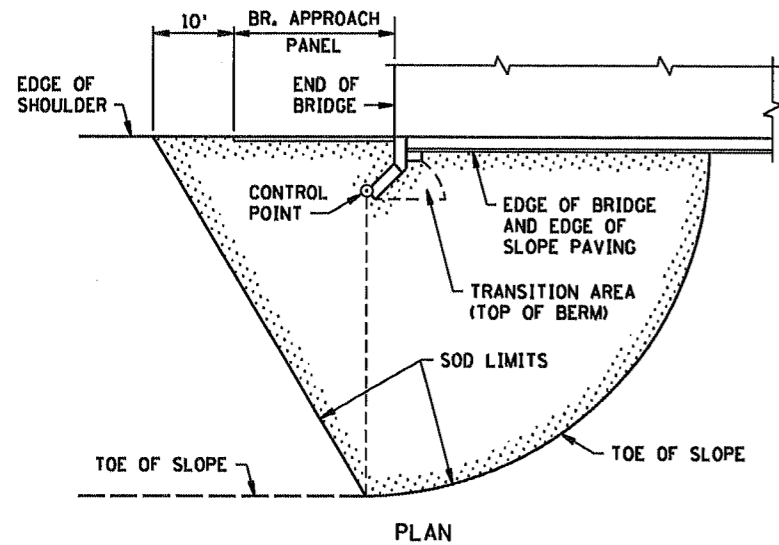

PLAN

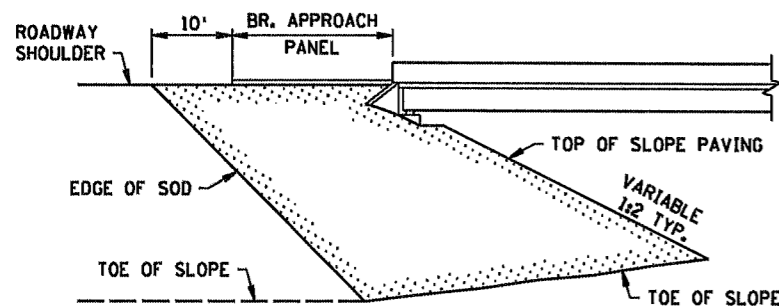

ELEVATION

SODDING LIMITS AT BRIDGE APPROACH FILLS

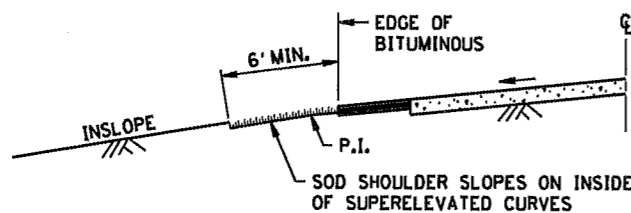

SODDING INSLOPES OF SUPERELEVATED CURVES

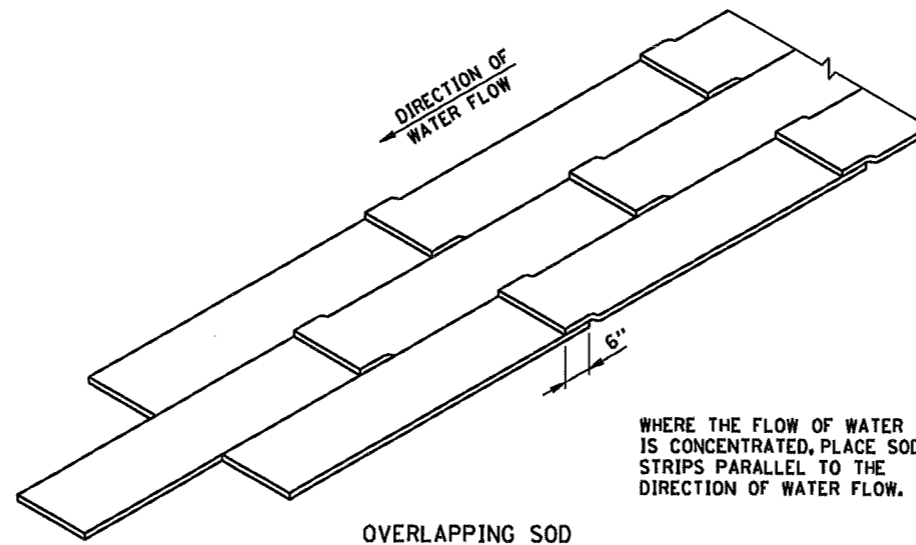

OVERLAPPING SOD

WHERE THE FLOW OF WATER IS CONCENTRATED, PLACE SOD STRIPS PARALLEL TO THE DIRECTION OF WATER FLOW.

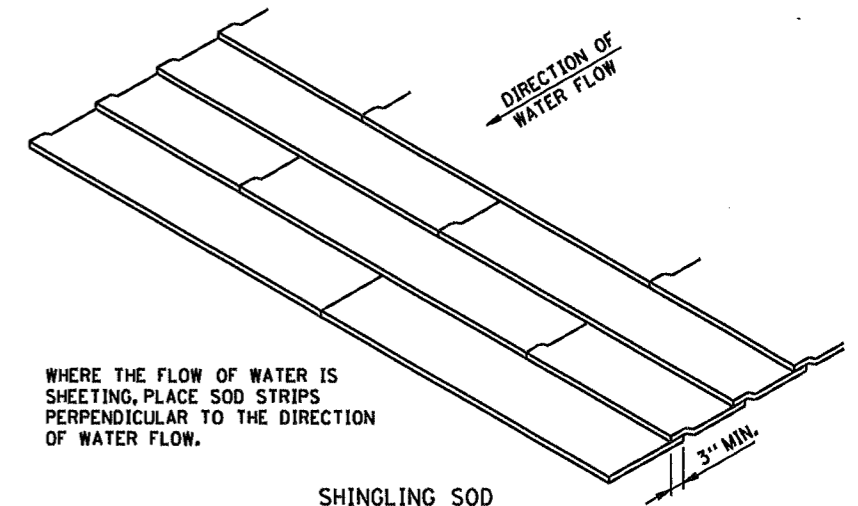

SHINGLING SOD

WHERE THE FLOW OF WATER IS SHEETING, PLACE SOD STRIPS PERPENDICULAR TO THE DIRECTION OF WATER FLOW.

SPECIAL SOD PLACEMENT TECHNIQUES

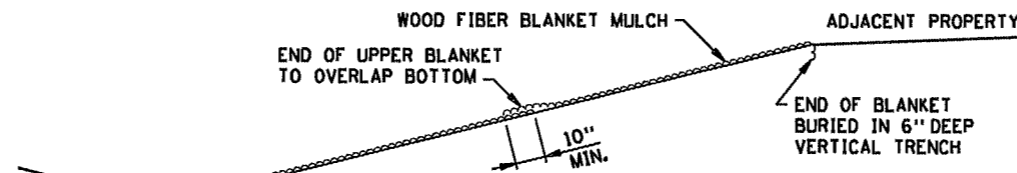

WOOD FIBER BLANKET INSTALLATION ON A CUT SLOPE

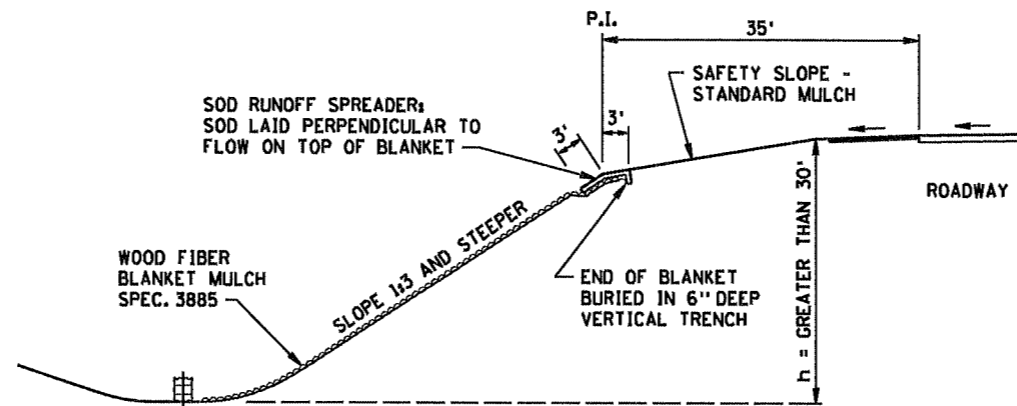

WOOD FIBER BLANKET INSTALLATION ON AN INSLOPE (WHEN REQUIRED)

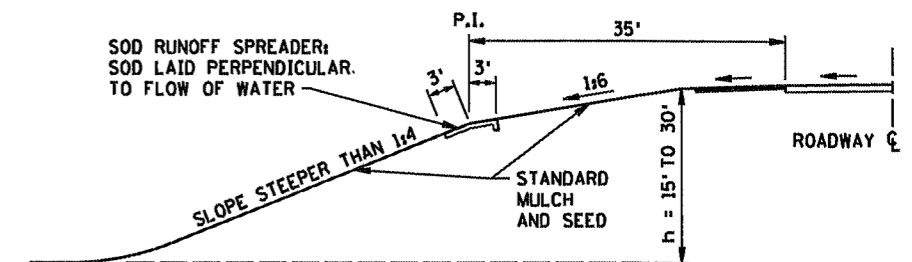

BROKEN-BACK SAFETY FILL SLOPE

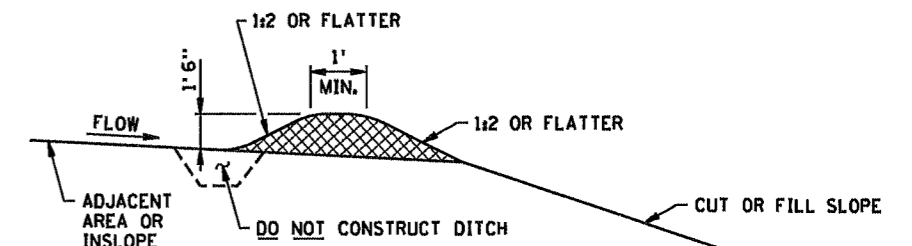

PERMANENT SLOPE PROTECTION DIKE

REVISION:
APPROVED: 8-6-2014
Chief Environmental Officer
CHIEF ENVIRONMENTAL OFFICER

REVISION:
APPROVED: 8-6-2014
Christopher Ky
STATE DESIGN ENGINEER

PERMANENT SEDIMENT CONTROL
ALONG ROADWAYS AND AT GORE AREAS & BRIDGE APPROACH FILLS
STANDARD PLAN 5-297.406
SP 002-678-022
SP 198-020-037
77 OF 126

LEGEND

- SEEDING
SEED TYPE 25 - 121
FERTILIZER TYPE 3
MULCH W/ DISK
ANCHORING
- SILT FENCE TYPE
MACHINE SLICED
- RIPRAP CLASS II
- BLANKET APRON
INLET OR OUTLET
- INLET PROTECTION
- PROPOSED CULVERT
- PROPOSED APRON
- INPLACE CULVERT
- WETLAND BOUNDARIES
- PROPOSED DRAINAGE
BASIN

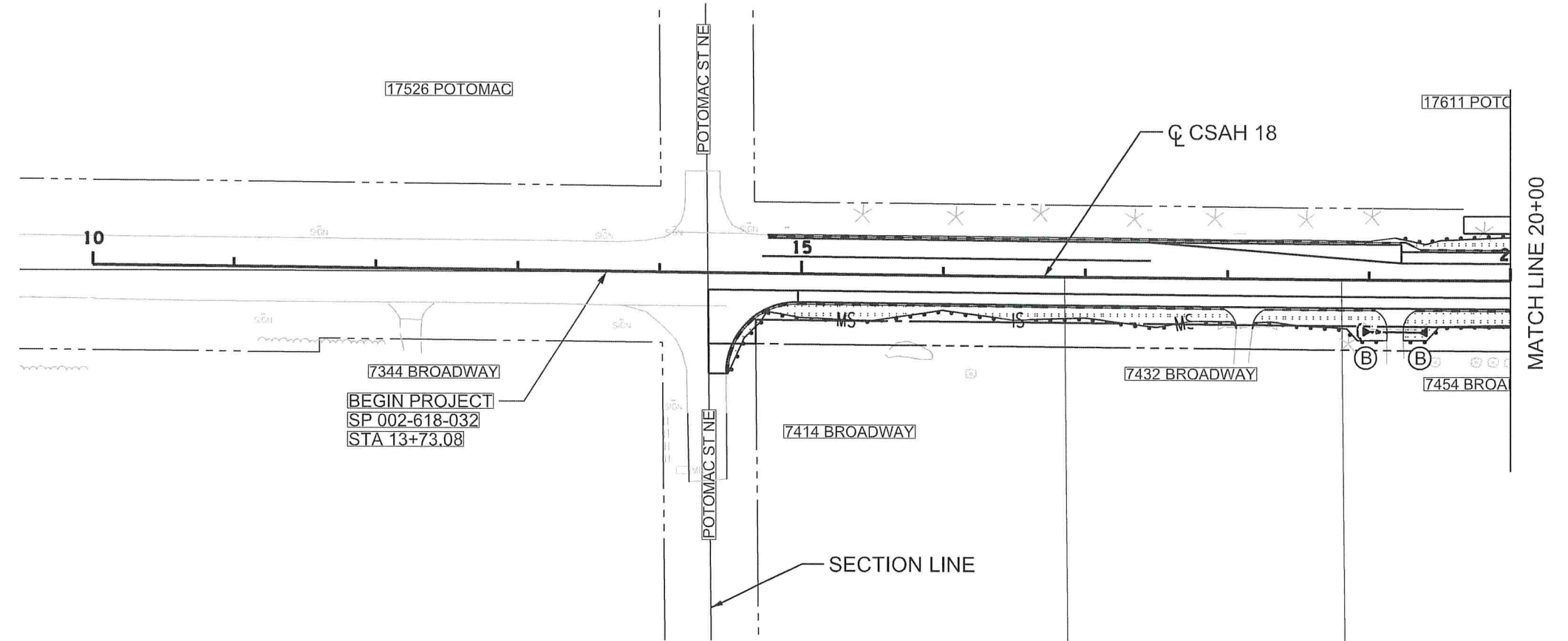
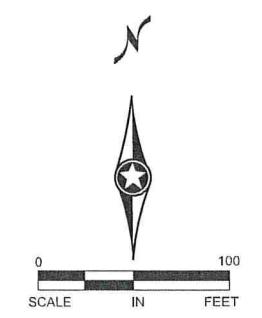

- NOTES**
- 1.) THE CONTRACTOR SHALL CONSTRUCT WASHED GRAVEL ENTRANCES AT POINTS OF EXIT FROM THE WORK AREA ONTO EXISTING BITUMINOUS PAVEMENT AS DIRECTED BY THE ENGINEER.
 - 2.) SILT FENCE SHALL FOLLOW AS CLOSE AS POSSIBLE A SINGLE CONTOUR.
 - 3.) SILT FENCE SHALL BE CLEANED OUT OR REPLACED WHEN SEDIMENT REACHES 8" OR $\frac{1}{3}$ OF SILT FENCE HEIGHT.
 - 4.) WHEN SEDIMENT DEPOSITS IN A WATER OF THE STATE, THE MATERIAL MUST BE REMOVED WITHIN 7 DAYS.
 - 5.) IF SILT DEPOSITS IN THE ANOKA COUNTY RIGHT-OF-WAY, THE CONTRACTOR IS RESPONSIBLE FOR ITS REMOVAL.
 - 6.) ALL GRADED AREAS ARE TO BE REVEGETATED WITHIN 7 DAYS OF THE COMPLETION OF GRADING.

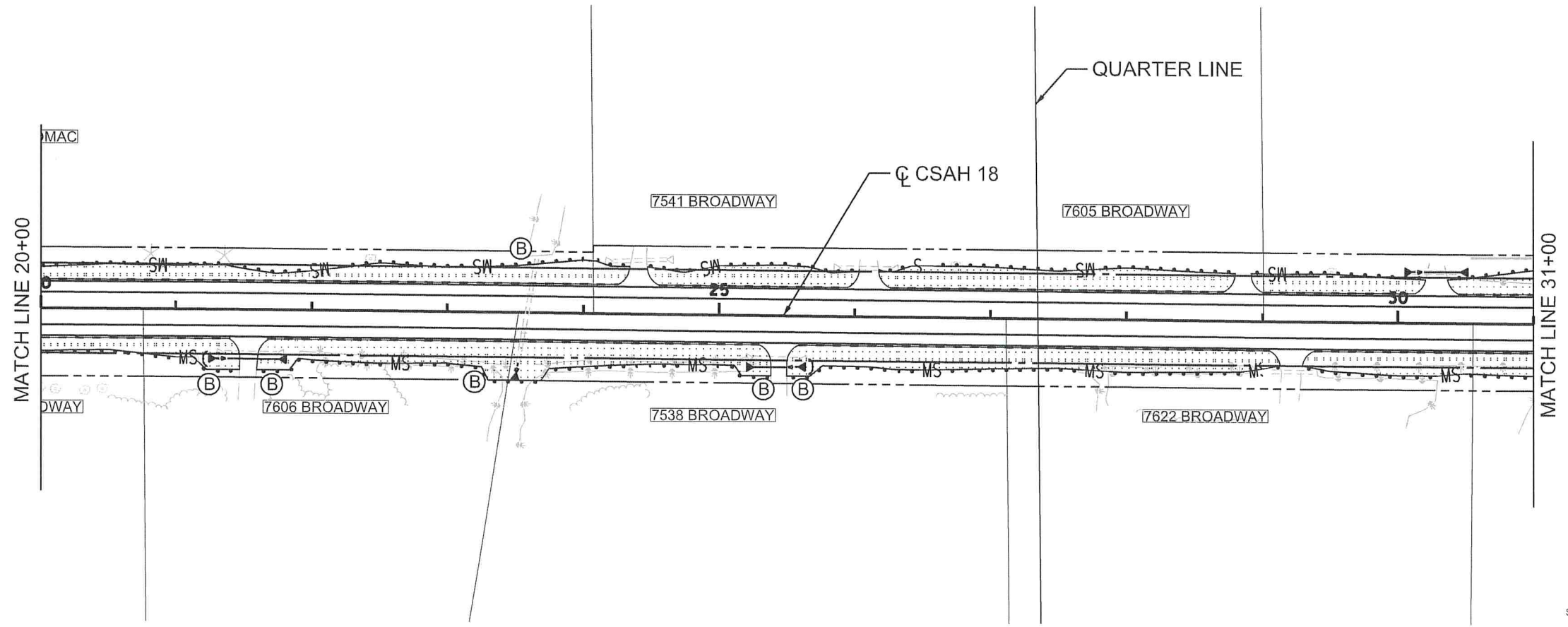
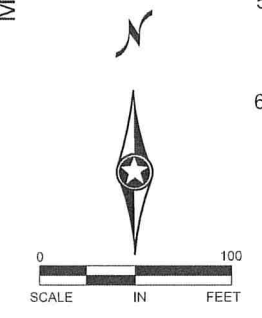

NO	DATE	BY	CKD	APPR	REVISION
NAME: P:\002-618-032\Plan\0261832_EC_P1.dgn					
01/28/2019 6:53:00 AM					

I HEREBY CERTIFY THAT THIS PLAN WAS PREPARED BY ME OR UNDER MY DIRECT SUPERVISION AND THAT I AM A DULY LICENSED PROFESSIONAL ENGINEER UNDER THE LAWS OF THE STATE OF MINNESOTA.

PRINT NAME: NICHOLAS DOBDA

SIGNATURE: *Nicholas Dobda*

DATE: 2-21-19 LICENSE NO. 49046

DRAWN BY: KT DATE: 10/24/18

DESIGN BY: JCF DATE: 10/24/18

CHECKED BY: NJD DATE: 10/24/18

ANOKA COUNTY
HIGHWAY DEPT.

SP 002-618-032

EROSION CONTROL PLAN
STA 13+72.99 TO 31+00.00
Sheet 78 of 126 Sheets

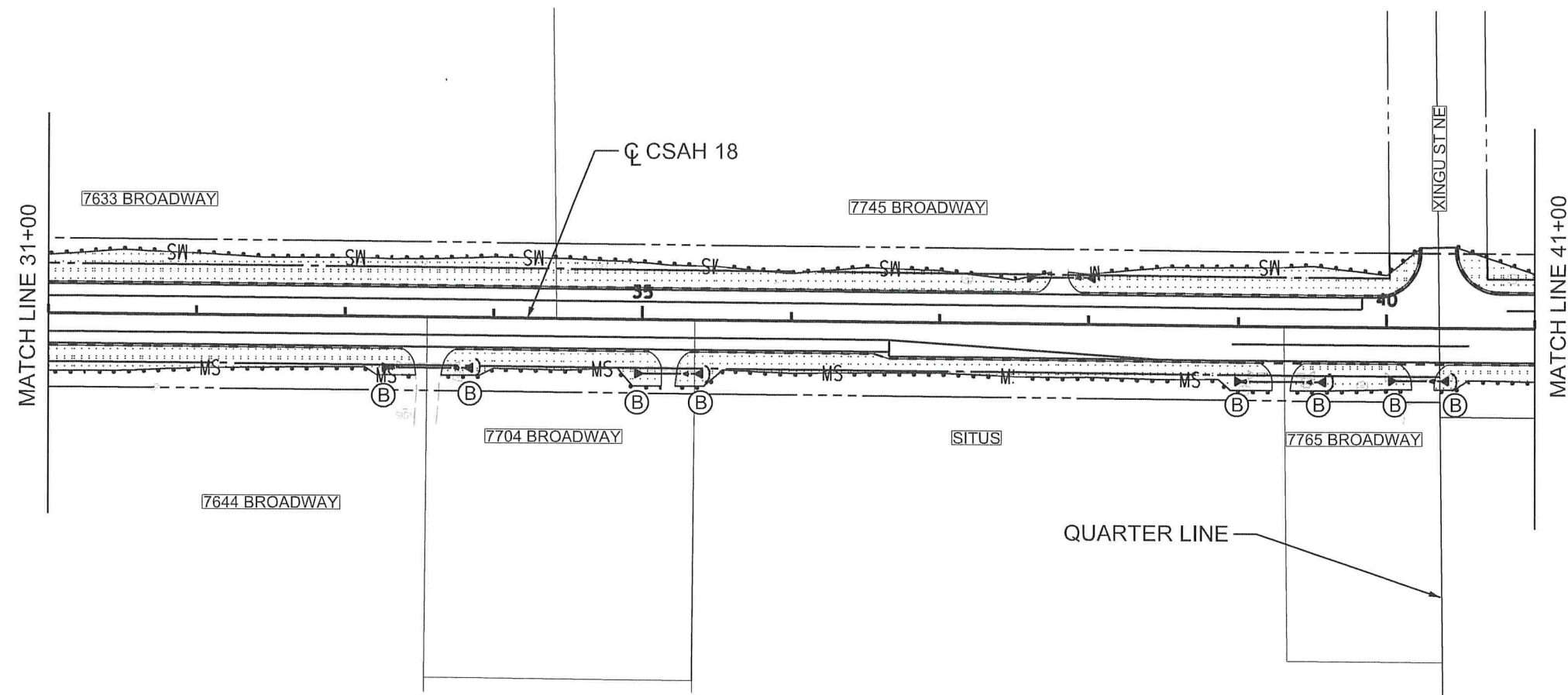

LEGEND	
	SEEDING SEED TYPE 25 - 121 FERTILIZER TYPE 3 MULCH W/ DISK ANCHORING
	SILT FENCE TYPE MACHINE SLICED
	RIPRAP CLASS II
	BLANKET APRON INLET OR OUTLET
	INLET PROTECTION
	PROPOSED CULVERT
	PROPOSED APRON
	INPLACE CULVERT
	WETLAND BOUNDARIES
	PROPOSED DRAINAGE BASIN

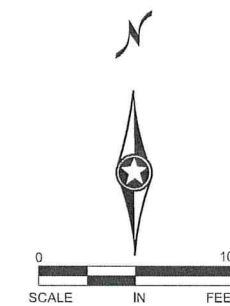
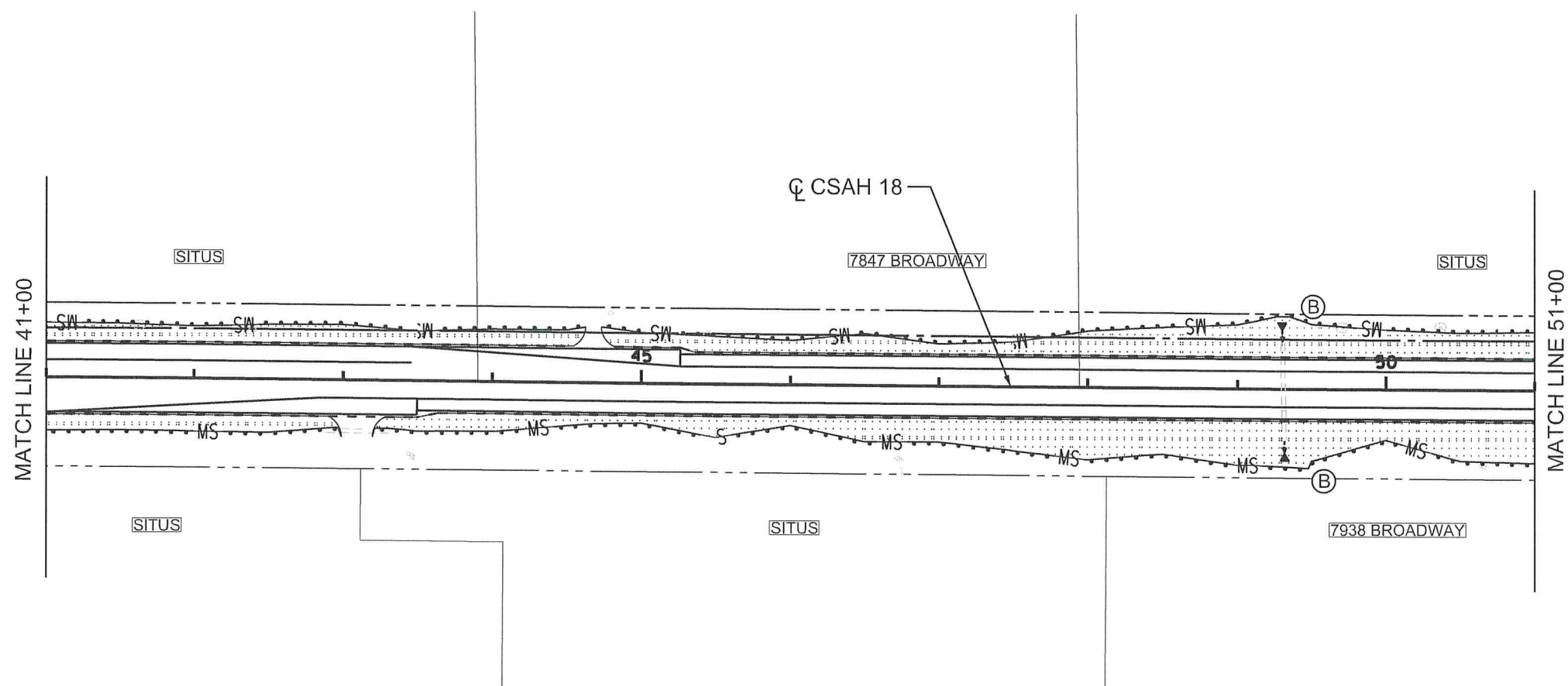
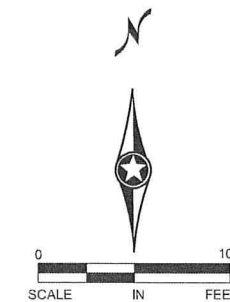

NOTES

- 1.) THE CONTRACTOR SHALL CONSTRUCT WASHED GRAVEL ENTRANCES AT POINTS OF EXIT FROM THE WORK AREA ONTO EXISTING BITUMINOUS PAVEMENT AS DIRECTED BY THE ENGINEER.
- 2.) SILT FENCE SHALL FOLLOW AS CLOSE AS POSSIBLE A SINGLE CONTOUR.
- 3.) SILT FENCE SHALL BE CLEANED OUT OR REPLACED WHEN SEDIMENT REACHES 8" OR $\frac{1}{3}$ OF SILT FENCE HEIGHT.
- 4.) WHEN SEDIMENT DEPOSITS IN A WATER OF THE STATE, THE MATERIAL MUST BE REMOVED WITHIN 7 DAYS.
- 5.) IF SILT DEPOSITS IN THE ANOKA COUNTY RIGHT-OF-WAY, THE CONTRACTOR IS RESPONSIBLE FOR ITS REMOVAL.
- 6.) ALL GRADED AREAS ARE TO BE REVEGETATED WITHIN 7 DAYS OF THE COMPLETION OF GRADING.

NO	DATE	BY	CKD	APPR	REVISION

NAME: P:\002-618-032\Plan\0261832_EC_P2.dgn 01/28/2019 6:53:02 AM

I HEREBY CERTIFY THAT THIS PLAN WAS PREPARED BY ME OR UNDER MY DIRECT SUPERVISION AND THAT I AM A DULY LICENSED PROFESSIONAL ENGINEER UNDER THE LAWS OF THE STATE OF MINNESOTA.
 PRINT NAME: NICHOLAS DOBDA
 SIGNATURE: *Nicholas Dobda*
 DATE: 2-21-19 LICENSE NO. 49046

DRAWN BY: KT DATE: 10/24/18
 DESIGN BY: JCF DATE: 10/24/18
 CHECKED BY: NJD DATE: 10/24/18

ANOKA COUNTY
HIGHWAY DEPT.

SP 002-618-032

EROSION CONTROL PLAN
 STA 31+00.00 TO 51+00.00
 Sheet 79 of 126 Sheets

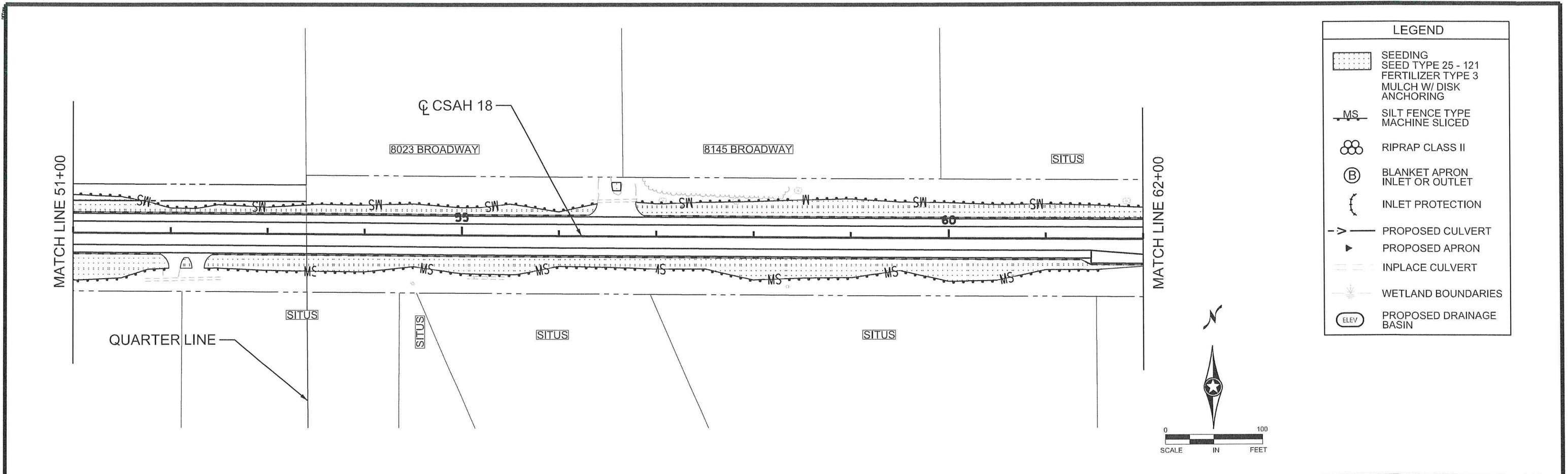

LEGEND	
	SEEDING SEED TYPE 25 - 121 FERTILIZER TYPE 3 MULCH W/ DISK ANCHORING
	SILT FENCE TYPE MACHINE SLICED
	RIPRAP CLASS II
	BLANKET APRON INLET OR OUTLET
	INLET PROTECTION
	PROPOSED CULVERT
	PROPOSED APRON
	INPLACE CULVERT
	WETLAND BOUNDARIES
	PROPOSED DRAINAGE BASIN

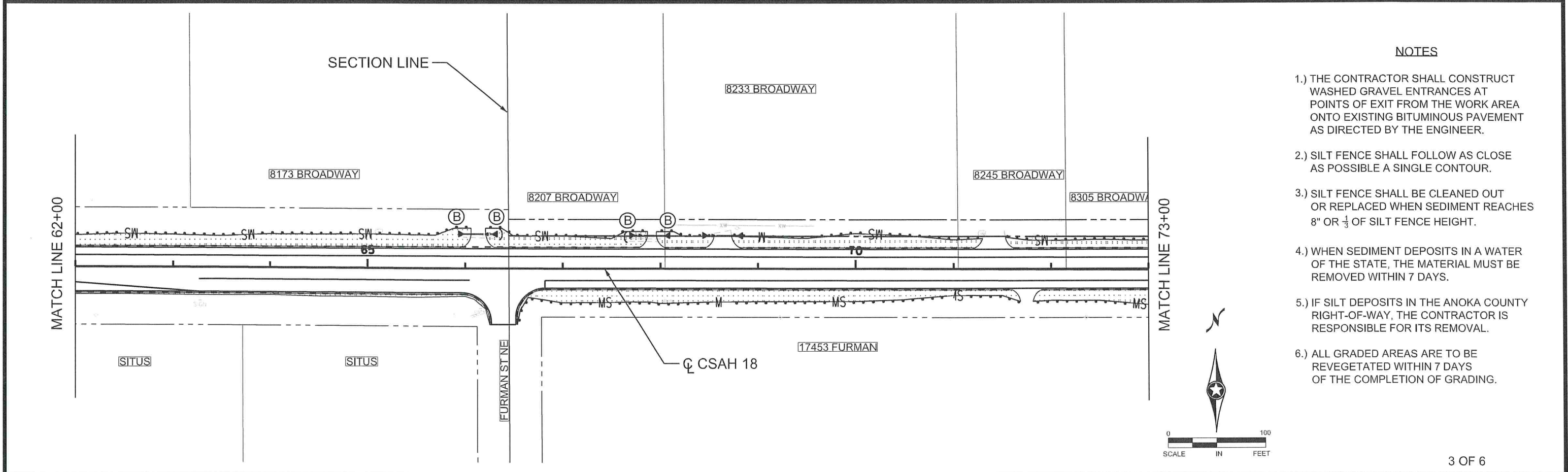

- NOTES**
- 1.) THE CONTRACTOR SHALL CONSTRUCT WASHED GRAVEL ENTRANCES AT POINTS OF EXIT FROM THE WORK AREA ONTO EXISTING BITUMINOUS PAVEMENT AS DIRECTED BY THE ENGINEER.
 - 2.) SILT FENCE SHALL FOLLOW AS CLOSE AS POSSIBLE A SINGLE CONTOUR.
 - 3.) SILT FENCE SHALL BE CLEANED OUT OR REPLACED WHEN SEDIMENT REACHES 8" OR $\frac{1}{3}$ OF SILT FENCE HEIGHT.
 - 4.) WHEN SEDIMENT DEPOSITS IN A WATER OF THE STATE, THE MATERIAL MUST BE REMOVED WITHIN 7 DAYS.
 - 5.) IF SILT DEPOSITS IN THE ANOKA COUNTY RIGHT-OF-WAY, THE CONTRACTOR IS RESPONSIBLE FOR ITS REMOVAL.
 - 6.) ALL GRADED AREAS ARE TO BE REVEGETATED WITHIN 7 DAYS OF THE COMPLETION OF GRADING.

NO	DATE	BY	CKD	APPR	REVISION

NAME: P:\002-618-032\Plan\0261832_EC_P3.dgn 01/28/2019 6:53:13 AM

I HEREBY CERTIFY THAT THIS PLAN WAS PREPARED BY ME OR UNDER MY DIRECT SUPERVISION AND THAT I AM A DULY LICENSED PROFESSIONAL ENGINEER UNDER THE LAWS OF THE STATE OF MINNESOTA.
 PRINT NAME: NICHOLAS DOBDA
 SIGNATURE: *Nicholas Dobda*
 DATE: 2-21-19 LICENSE NO. 49046

DRAWN BY: KT DATE: 10/24/18
 DESIGN BY: JCF DATE: 10/24/18
 CHECKED BY: NJD DATE: 10/24/18

**ANOKA COUNTY
HIGHWAY DEPT.**

SP 002-618-032

EROSION CONTROL PLAN
 STA 51+00.00 TO 73+00.00
 Sheet 80 of 126 Sheets

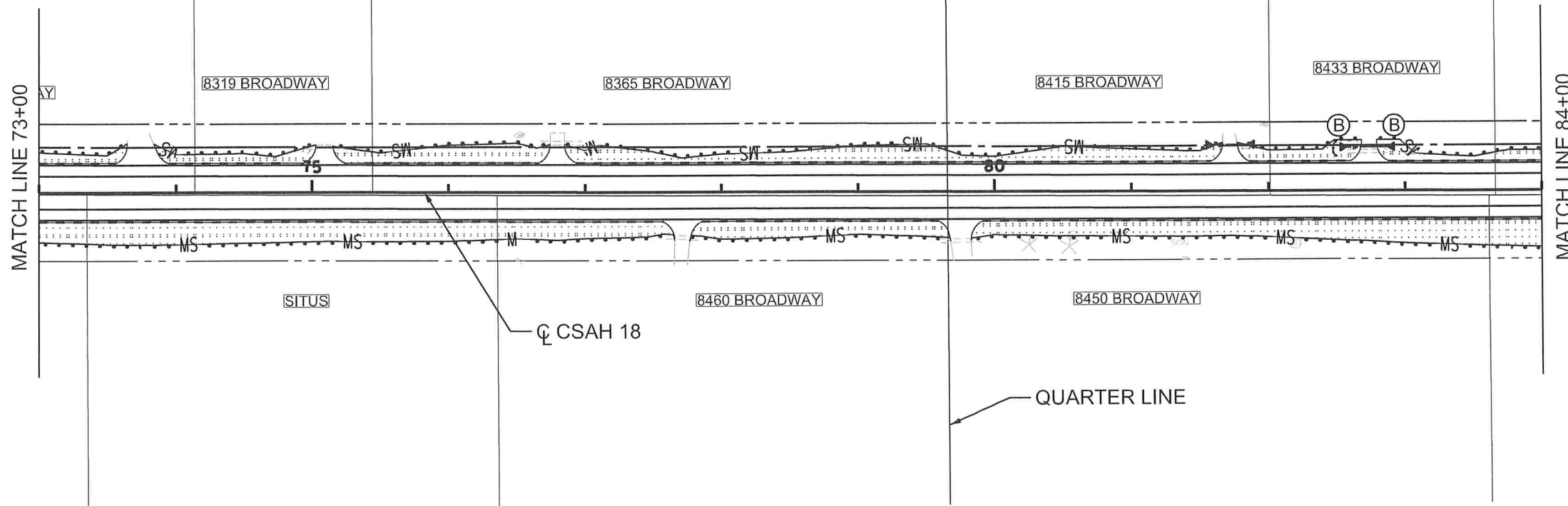

LEGEND	
	SEEDING SEED TYPE 25 - 121 FERTILIZER TYPE 3 MULCH W/ DISK ANCHORING
	SILT FENCE TYPE MACHINE SLICED
	RIPRAP CLASS II
	BLANKET APRON INLET OR OUTLET
	INLET PROTECTION
	PROPOSED CULVERT
	PROPOSED APRON
	INPLACE CULVERT
	WETLAND BOUNDARIES
	PROPOSED DRAINAGE BASIN

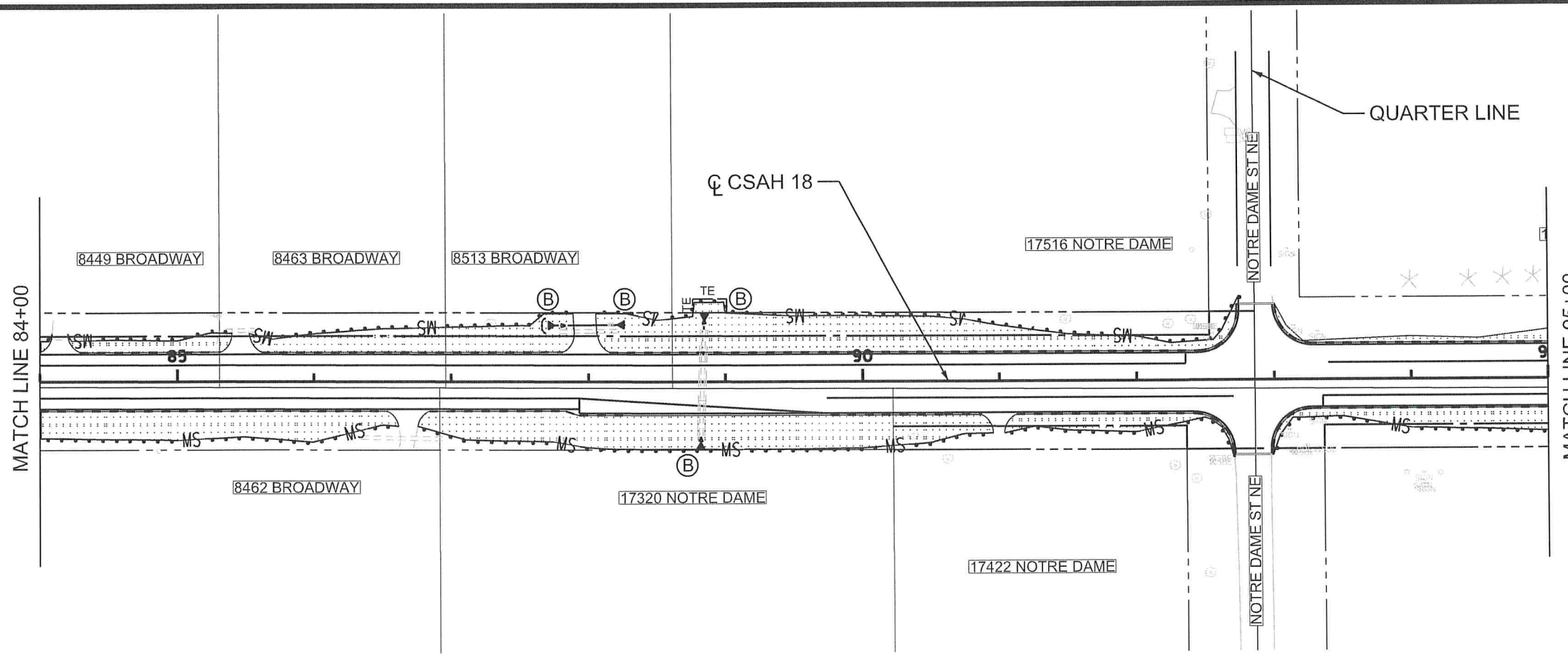
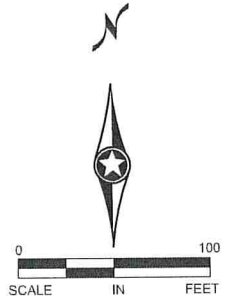

- NOTES**
- 1.) THE CONTRACTOR SHALL CONSTRUCT WASHED GRAVEL ENTRANCES AT POINTS OF EXIT FROM THE WORK AREA ONTO EXISTING BITUMINOUS PAVEMENT AS DIRECTED BY THE ENGINEER.
 - 2.) SILT FENCE SHALL FOLLOW AS CLOSE AS POSSIBLE A SINGLE CONTOUR.
 - 3.) SILT FENCE SHALL BE CLEANED OUT OR REPLACED WHEN SEDIMENT REACHES 8" OR $\frac{1}{3}$ OF SILT FENCE HEIGHT.
 - 4.) WHEN SEDIMENT DEPOSITS IN A WATER OF THE STATE, THE MATERIAL MUST BE REMOVED WITHIN 7 DAYS.
 - 5.) IF SILT DEPOSITS IN THE ANOKA COUNTY RIGHT-OF-WAY, THE CONTRACTOR IS RESPONSIBLE FOR ITS REMOVAL.
 - 6.) ALL GRADED AREAS ARE TO BE REVEGETATED WITHIN 7 DAYS OF THE COMPLETION OF GRADING.

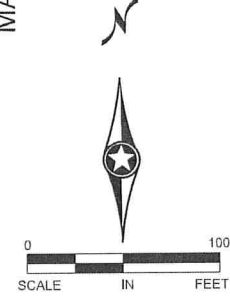

NO	DATE	BY	CKD	APPR	REVISION

NAME: P:\002-618-032\Plan\0261832_EC_P4.dgn 01/28/2019 6:53:15 AM

I HEREBY CERTIFY THAT THIS PLAN WAS PREPARED BY ME OR UNDER MY DIRECT SUPERVISION AND THAT I AM A DULY LICENSED PROFESSIONAL ENGINEER UNDER THE LAWS OF THE STATE OF MINNESOTA.
 PRINT NAME: NICHOLAS DOBDA
 SIGNATURE: *[Signature]*
 DATE: 2-21-19 LICENSE NO. 49046

DRAWN BY: KT DATE: 10/24/18
 DESIGN BY: JCF DATE: 10/24/18
 CHECKED BY: NJD DATE: 10/24/18

ANOKA COUNTY
 HIGHWAY DEPT.

SP 002-618-032
 EROSION CONTROL PLAN
 STA 73+00.00 TO 95+00.00
 Sheet 81 of 126 Sheets

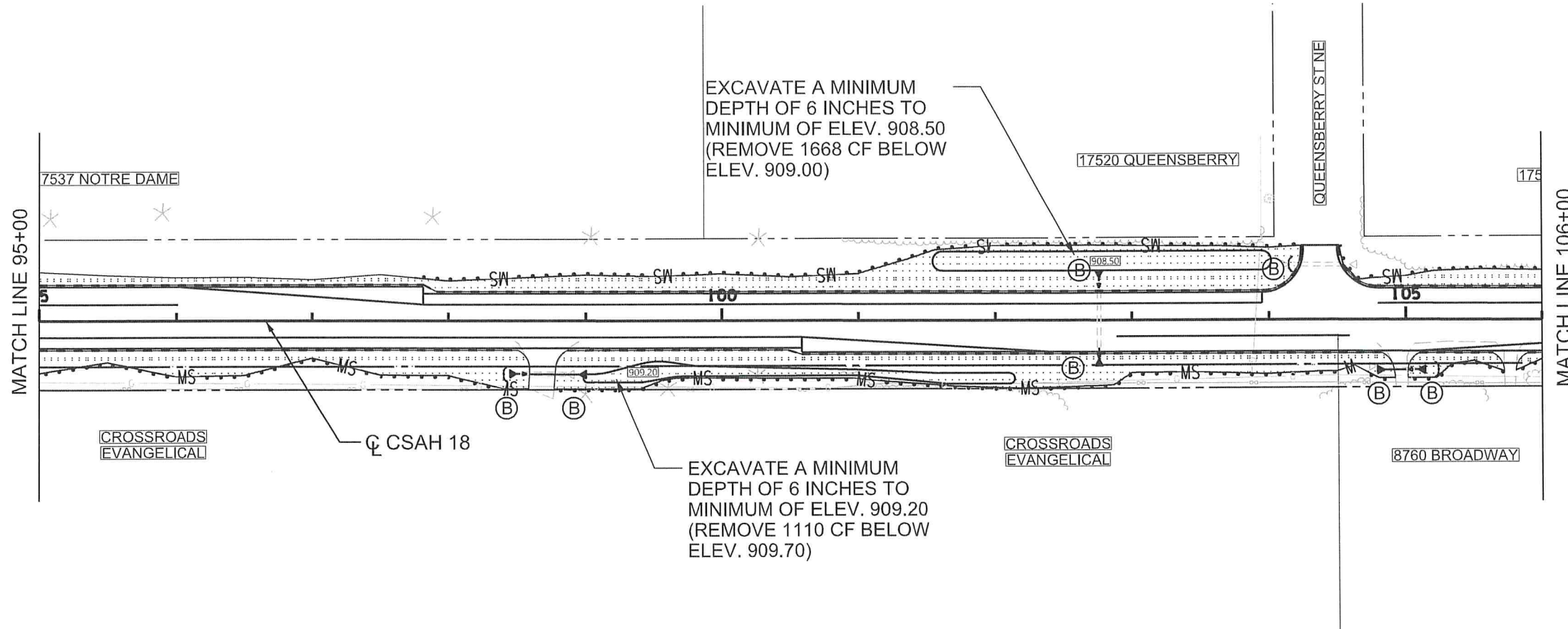

LEGEND	
	SEEDING SEED TYPE 25 - 121 FERTILIZER TYPE 3 MULCH W/ DISK ANCHORING
	SILT FENCE TYPE MACHINE SLICED
	RIPRAP CLASS II
	BLANKET APRON INLET OR OUTLET
	INLET PROTECTION
	PROPOSED CULVERT
	PROPOSED APRON
	INPLACE CULVERT
	WETLAND BOUNDARIES
	PROPOSED DRAINAGE BASIN

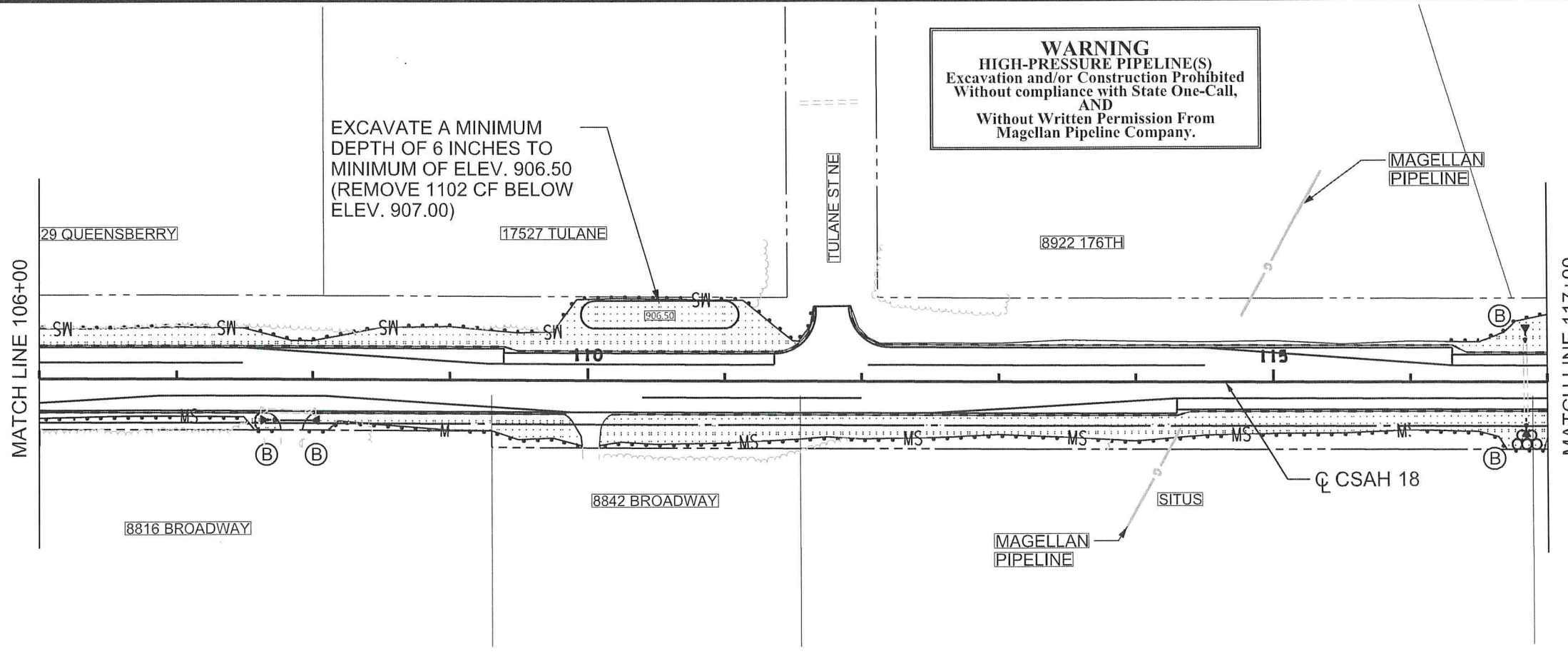
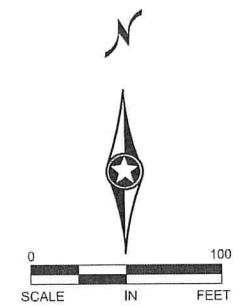

- NOTES**
- 1.) THE CONTRACTOR SHALL CONSTRUCT WASHED GRAVEL ENTRANCES AT POINTS OF EXIT FROM THE WORK AREA ONTO EXISTING BITUMINOUS PAVEMENT AS DIRECTED BY THE ENGINEER.
 - 2.) SILT FENCE SHALL FOLLOW AS CLOSE AS POSSIBLE A SINGLE CONTOUR.
 - 3.) SILT FENCE SHALL BE CLEANED OUT OR REPLACED WHEN SEDIMENT REACHES 8" OR 1/3 OF SILT FENCE HEIGHT.
 - 4.) WHEN SEDIMENT DEPOSITS IN A WATER OF THE STATE, THE MATERIAL MUST BE REMOVED WITHIN 7 DAYS.
 - 5.) IF SILT DEPOSITS IN THE ANOKA COUNTY RIGHT-OF-WAY, THE CONTRACTOR IS RESPONSIBLE FOR ITS REMOVAL.
 - 6.) ALL GRADED AREAS ARE TO BE REVEGETATED WITHIN 7 DAYS OF THE COMPLETION OF GRADING.

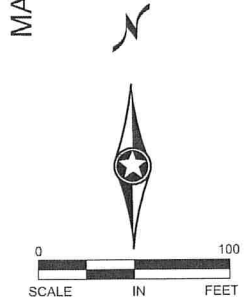

NO	DATE	BY	CKD	APPR	REVISION

NAME: P:\002-618-032\Plan\0261832_EC_P5.dgn 01/28/2019 6:53:17 AM

I HEREBY CERTIFY THAT THIS PLAN WAS PREPARED BY ME OR UNDER MY DIRECT SUPERVISION AND THAT I AM A DULY LICENSED PROFESSIONAL ENGINEER UNDER THE LAWS OF THE STATE OF MINNESOTA.
 PRINT NAME: NICHOLAS DOBDA
 SIGNATURE: *Nicholas Dobda*
 DATE: 2-21-19 LICENSE NO. 49046

DRAWN BY: KT DATE: 10/24/18
 DESIGN BY: JCF DATE: 10/24/18
 CHECKED BY: NJD DATE: 10/24/18

ANOKA COUNTY
HIGHWAY DEPT.

SP 002-618-032

EROSION CONTROL PLAN
 STA 95+00.00 TO 117+00.00
 Sheet 82 of 126 Sheets

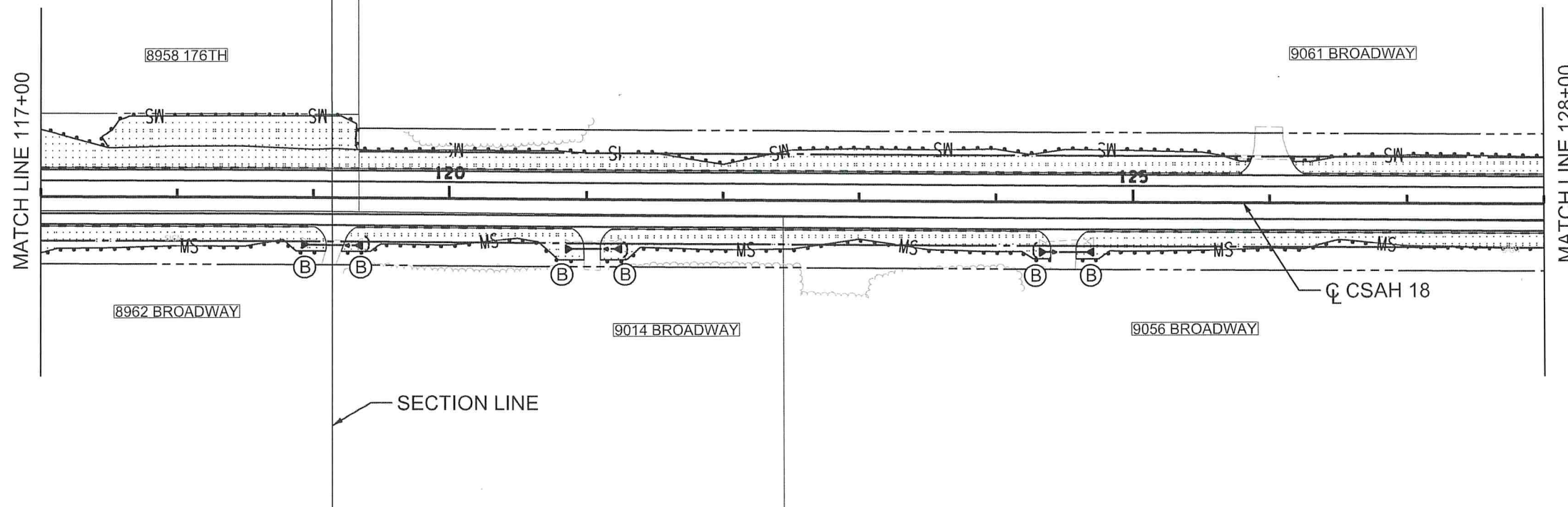

LEGEND	
	SEEDING SEED TYPE 25 - 121 FERTILIZER TYPE 3 MULCH W/ DISK ANCHORING
	SILT FENCE TYPE MACHINE SLICED
	RIPRAP CLASS II
	BLANKET APRON INLET OR OUTLET
	INLET PROTECTION
	PROPOSED CULVERT
	PROPOSED APRON
	INPLACE CULVERT
	WETLAND BOUNDARIES
	PROPOSED DRAINAGE BASIN

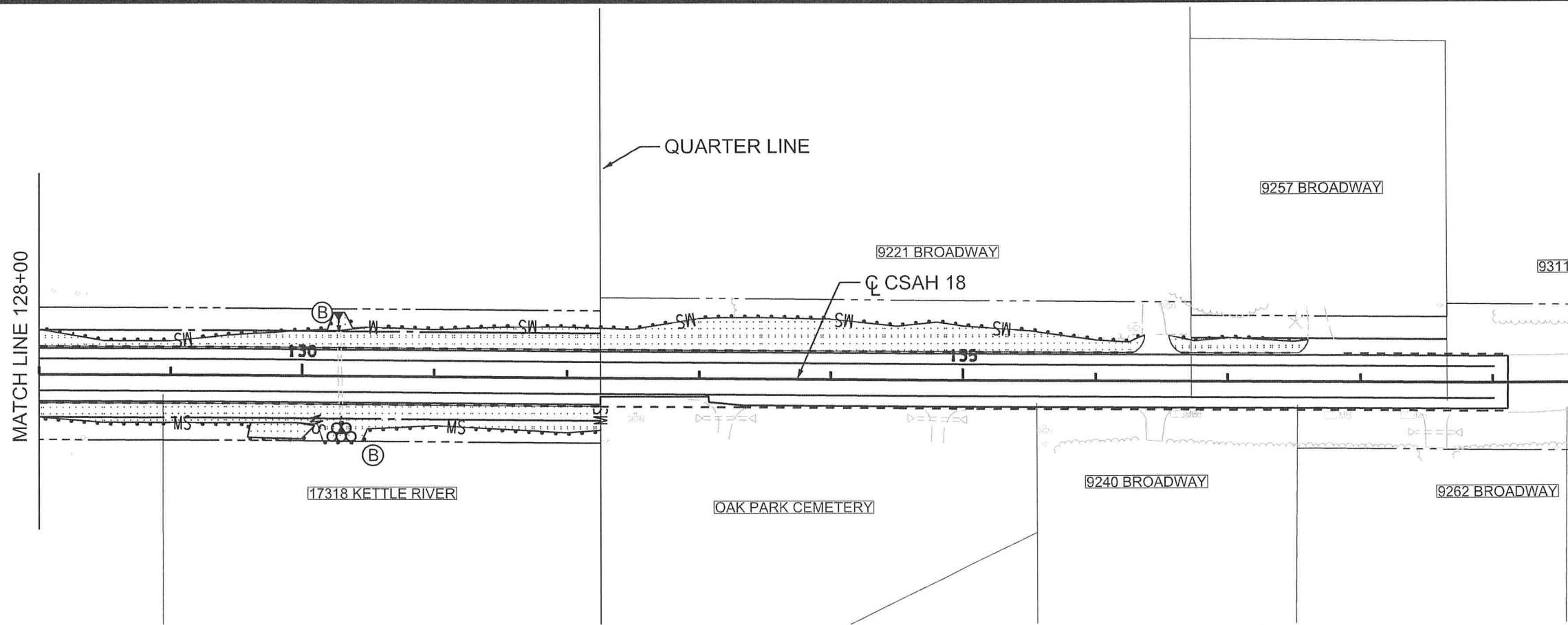
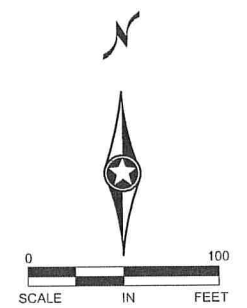

- NOTES**
- 1.) THE CONTRACTOR SHALL CONSTRUCT WASHED GRAVEL ENTRANCES AT POINTS OF EXIT FROM THE WORK AREA ONTO EXISTING BITUMINOUS PAVEMENT AS DIRECTED BY THE ENGINEER.
 - 2.) SILT FENCE SHALL FOLLOW AS CLOSE AS POSSIBLE A SINGLE CONTOUR.
 - 3.) SILT FENCE SHALL BE CLEANED OUT OR REPLACED WHEN SEDIMENT REACHES 8" OR $\frac{1}{3}$ OF SILT FENCE HEIGHT.
 - 4.) WHEN SEDIMENT DEPOSITS IN A WATER OF THE STATE, THE MATERIAL MUST BE REMOVED WITHIN 7 DAYS.
 - 5.) IF SILT DEPOSITS IN THE ANOKA COUNTY RIGHT-OF-WAY, THE CONTRACTOR IS RESPONSIBLE FOR ITS REMOVAL.
 - 6.) ALL GRADED AREAS ARE TO BE REVEGETATED WITHIN 7 DAYS OF THE COMPLETION OF GRADING.

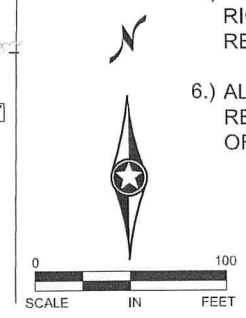

NO	DATE	BY	CKD	APPR	REVISION

NAME: P:\002-618-032\Plan\0261832_EC_P6.dgn 01/28/2019 6:53:19 AM

I HEREBY CERTIFY THAT THIS PLAN WAS PREPARED BY ME OR UNDER MY DIRECT SUPERVISION AND THAT I AM A DULY LICENSED PROFESSIONAL ENGINEER UNDER THE LAWS OF THE STATE OF MINNESOTA.

PRINT NAME: NICHOLAS DOBDA

SIGNATURE:

DATE: 2-21-19 LICENSE NO. 49046

DRAWN BY: KT DATE: 10/24/18

DESIGN BY: JCF DATE: 10/24/18

CHECKED BY: NJD DATE: 10/24/18

ANOKA COUNTY HIGHWAY DEPT.

SP 002-618-032

EROSION CONTROL PLAN

STA 117+00.00 TO 139+17.62

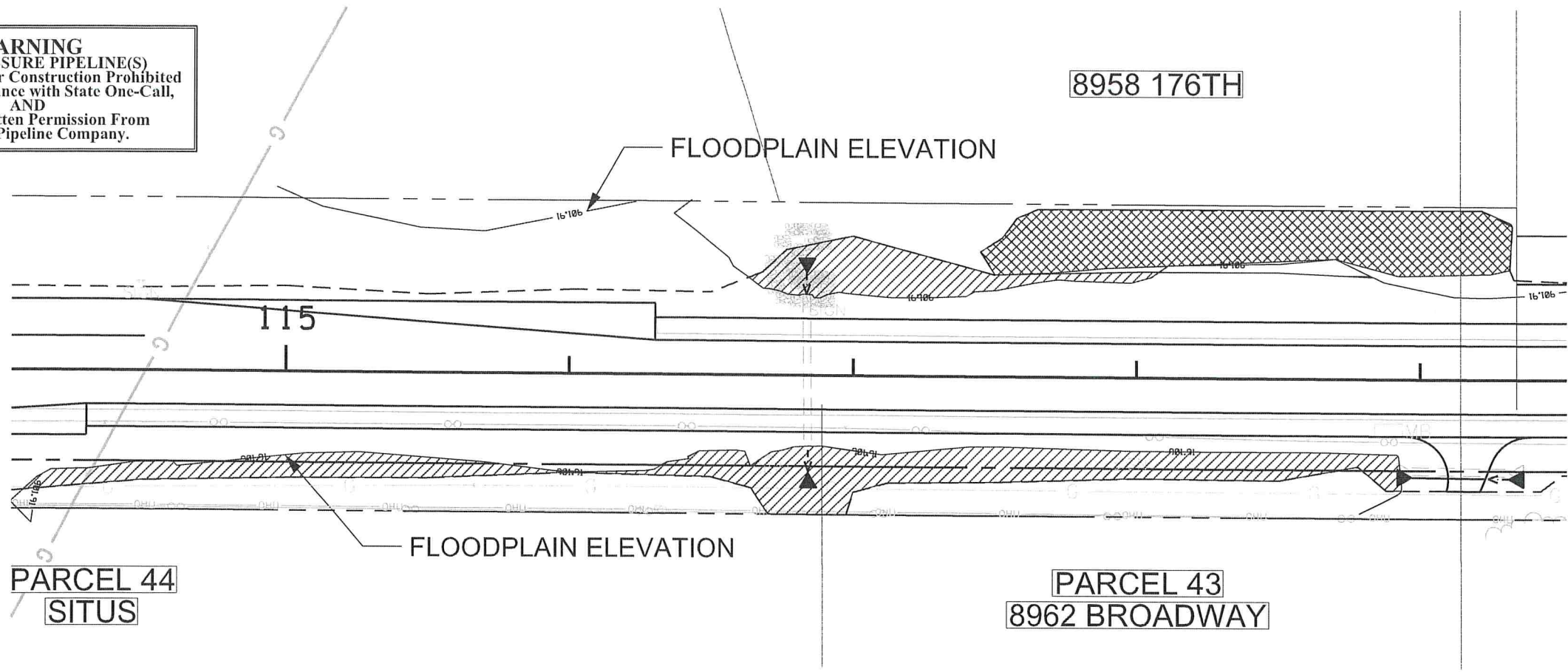

Sheet 83 of 126 Sheets

WARNING
 HIGH-PRESSURE PIPELINE(S)
 Excavation and/or Construction Prohibited
 Without compliance with State One-Call,
 AND
 Without Written Permission From
 Magellan Pipeline Company.

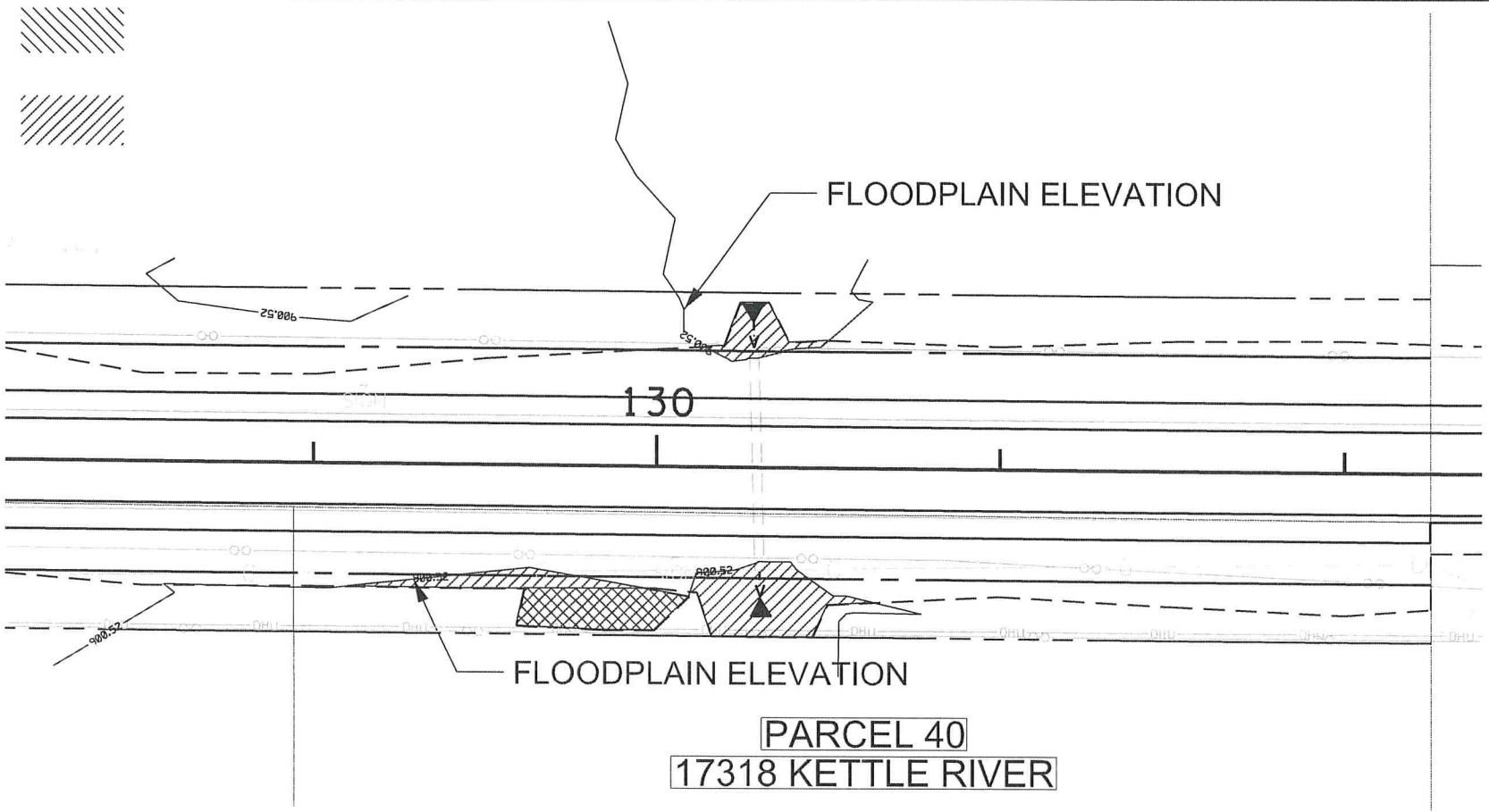

 MITIGATION (136.4 CY)
 FILL (125.1 CY)
 FLOODPLAIN ELEVATION 901.91



 MITIGATION (19.1 CY)
 FILL (17.3 CY)
 FLOODPLAIN ELEVATION 900.52

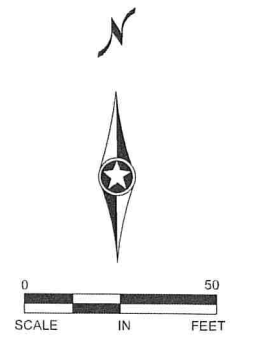

NO	DATE	BY	CHKD	APPR	REVISION

NAME: P:\002-618-032\Plan\0261832_DR_P1.dgn 01/28/2019 6:53:24 AM

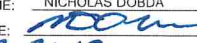
I HEREBY CERTIFY THAT THIS PLAN WAS PREPARED BY ME OR UNDER MY DIRECT SUPERVISION AND THAT I AM A DULY LICENSED PROFESSIONAL ENGINEER UNDER THE LAWS OF THE STATE OF MINNESOTA.
 PRINT NAME: NICHOLAS DOBDA
 SIGNATURE: 
 DATE: 2-21-19 LICENSE NO. 49046

DRAWN BY: KT DATE: 10/24/18
 DESIGN BY: JCF DATE: 10/24/18
 CHECKED BY: NJD DATE: 10/24/18

 ANOKA COUNTY
 HIGHWAY DEPT.

SP 002-618-032

FLOODPLAIN MITIGATION
 Sheet 84 of 126 Sheets

PROJECT LOCATION AND GENERAL INFORMATION

THIS ROAD CONSTRUCTION PROJECT ADDS 8.0' PAVED SHOULDER, RIGHT TURN LANES AND BYPASS LANES TO ROADWAY.
THIS PROJECT WILL PRIMARILY CONSIST OF GRADING, PLACING AGGREGATE BASE, BITUMINOUS PAVING, CULVERT EXTENTIONS AND CULVERT REPLACEMENT.

THIS PROJECT WILL REQUIRE THE DISTURBANCE OF 11.27 ACRES OF SOILS AND DOES CREATE THE POTENTIAL FOR SEDIMENT DISCHARGE FROM THE SITE.

TRAINING REQUIREMENTS

THE CONTRACTOR WILL ENSURE COMPLIANCE WITH THE TRAINING REQUIRED IN PART 111.A.2 OF THE GENERAL STORMWATER PERMIT FOR CONSTRUCTION ACTIVITY.

THE INDIVIDUALS TRAINED AND THE TRAINING RECEIVED WILL BE RECORDED IN THE SWPPP BEFORE THE START OF CONSTRUCTION OR AS SOON AS PERSONEL FOR THE PROJECT HAVE BEEN DETERMINED.

LONG TERM OPERATION AND MAINTENANCE

ANOKA COUNTY WILL BE RESPONSIBLE FOR THE LONG TERM OPERATION AND MAINTENANCE OF THE PERMANENT STORMWATER MANAGEMENT AND SNOW REMOVAL OPERATIONS.

ANOKA COUNTY HIGHWAY DEPARTMENT
1440 BUNKER LAKE BLVD.
CITY OF ANDOVER
ANDOVER, MN 55304
(763) 324-3100

RECEIVING SURFACE WATERS, DISCHARGE TO IMPAIRED WATERS & SPECIAL WATERS

THE FOLLOWING TABLE IDENTIFIES ALL SURFACE WATERS WITHIN 1 MILE OF THE PROJECT DISTURBED SOIL BOUNDARIES, WHICH WILL RECEIVE STORMWATER RUNOFF FROM THE CONSTRUCTION SITE, DURING OR AFTER CONSTRUCTION.

STORMWATER FROM A DISCHARGE POINT ON THE PROJECT THAT FLOWS TO A SURFACE WATER IDENTIFIED AS IMPAIRED AND/OR SPECIAL MUST INCLUDE THE FOLLOWING ADDITIONAL BMP REQUIREMENTS:

- 1) ALL EXPOSED SOIL AREAS MUST BE STABILIZED AS SOON AS POSSIBLE TO LIMIT SOIL EROSION BUT IN NO CASE LATER THAN SEVEN (7) DAYS AFTER THE CONSTRUCTION ACTIVITY IN THAT PORTION OF THE SITE HAS TEMPORARILY OR PERMANENTLY CEASED.
- 2) TEMPORARY SEDIMENT BASINS OR PERMANENT PONDS MUST BE USED FOR COMMON DRAINAGE LOCATIONS THAT SERVE AN AREA WITH FIVE (10+) OR MORE ACRES DISTURBED AT ONE TIME.

RECEIVING SURFACE WATERS WITHIN 1 MILE OF PROJECT					
NAME OF WATER BODY	SPECIAL	IMPAIRED	TMDL NEEDED	TMDL APPROVED FOR	TMDL NOT REQUIRED
UNNAMED CREEK	NO	NO	NONE	NONE	NONE

DISTURBED SOIL AREA / PERDOMINANT SOIL ON PROJECT - SAND
TOTAL DISTURBED SOILS AREA FOR THIS PROJECT IS 11.27 ACRES

IMPERVIOUS AREA
EXISTING AREA OF IMPERVIOUS SURFACE IS 9.28 ACRES.

POST CONSTRUCTION AREA OF IMPERVIOUS SURFACE 12.33 ACRES.

SEDIMENT CONTROL PRACTICES

IN-WATER SEDIMENT CONTROL MEASURES MUST BE PROPERLY INSTALLED AND MUST BE MAINTAINED FOR THE DURATION OF THE IN-WATER DISTURBANCES. THE CHOSEN MEASURES MUST BE MONITORED TO ENSURE TURBIDITY OR SEDIMENTATION ARE NOT OCCURRING OUTSIDE THE EXPECTED AREA OF IMPACT. IF THE MEASURES FAIL TO CONTAIN SEDIMENT OR TURBIDITY THE PERMITTEE MUST IMMEDIATELY REPAIR, REPLACE OR USE ALTERNATIVE MEASURES, WHICH WILL ADEQUATLY CONTROL TURBIDITY AND SEDIMENTATION.

TEMPORARY STOCKPILED TOPSOIL BERMS MUST INCLUDE PERIMETER BMP'S AS PROVIDED IN THE PLAN AT LOCATIONS WHERE CONSTRUCTION STORMWATER DRAINS FROM THE PROJECT

IN ORDER TO MAINTAIN SHEET FLOW AND MINIMIZE RILLS AND/OR GULLIES, THERE SHALL BE NO UNBROKEN SLOPE LENGTH OF GREATER THAN 75 FEET FOR SLOPES WITH A GRADE OF 1:3 OR STEEPER

ALL STORM DRAIN INLETS MUST BE PROTECTED BY APPROPRIATE BMP'S DURING CONSTRUCTION UNTIL ALL SOURCES WITH POTENTIAL DISCHARGE TO THE INLET HAVE BEEN STABILIZED

VEHICLE TRACKING OF SEDIMENT FROM THE CONSTRUCTION SITE MUST BE MINIMIZED. STREET SWEEPING MUST BE USED IF SEDIMENT IS BEING TRACKED OFF THE CONSTRUCTION SITE

POLLUTION PROVENTION MEASURES

THE CONTRACTOR WILL IMPLEMENT THE POLLUTION PREVENTION MANAGEMENT MEASURES AS DIRECTED IN THE NPDES PERMIT PART IV.F AS PERTAINING TO SOLID WASTE, HAZARDOUS MATERIALS EXTERNAL TRUCK WASHING, AND CONCRETE WASHOUT ONSITE.

CONSTRUCTION PHASING

SILT FENCE AND/OR OTHER SUITABLE PERIMETER BMP'S AS PROVIDED IN THE PLANS WILL BE INSTALLED PRIOR TO THE START OF ANY LAND DISTURBING ACTIVITY. CONSTRUCTION WILL BE REQUIRED TO BE PHASED SO THAT ALL DOWN GRADIENT SEDIMENT CONTROL MEASURES ARE INSTALLED PRIOR TO OR IN CONJUNCTION WITH ANY SOIL DISTURBING ACTIVITIES.

WHEN TOPSOIL IS DISTURBED, THE TOPSOIL WILL BE STRIPPED AND STOCKPILED IN SOIL BERMS AT THE TOE OF THE STRIPPED SLOPES ALONG THE PROJECT LIMITS. TEMPORARY VEGETATION WILL BE ESTABLISHED ON THE STOCKPILED TOPSOIL BERMS WITH RAPID STABILIZATION AS PROVIDED IN THE PLAN. STOCKPILED TOPSOIL BERMS WILL NOT BE PLACED IN ANY STORMWATER CONVEYANCES.

AFTER STRIPPING THE TOPSOIL THE EXPOSED SOIL INSLOPES WILL BE STABILIZED WITH DISK ANCHORED TYPE 3 MULCH AND SEED WITHIN 7 DAYS OR RAPID STABILIZATION 7 DAYS AFTER THE CONSTRUCTION ACTIVITY IN THAT PORTION OF THE SITE HAS BEEN TEMPORARILY OR PERMANENTLY CEASED.

TEMPORARY SEDIMENT BASINS

THIS ROAD CONSTRUCTION PROJECT AS DESIGNED DOES NOT MEET ANY OF THE TEMPORARY SEDIMENT BASIN DISTURBED AREA THRESHOLD REQUIREMENTS IF PERMANENT POND LOCATIONS ARE CONSTRUCTED PRIOR TO DISCHARGE. TEMPORARY SEDIMENT BASINS WILL NOT BE REQUIRED.

PERMANENT STORMWATER MANAGEMENT SYSTEM

ALL STORMWATER MUST BE DISCHARGED IN A MANNER THAT DOES NOT CAUSE NUISANCE CONDITIONS, EROSION IN RECEIVING WATERS OR ON DOWNSLOPE PROPERTIES, OR INUNDATION IN WETLANDS CAUSING A SIGNIFICANT ADVERSE IMPACT TO THE WETLAND.

EROSION PREVENTION PRACTICES

ALL EXPOSED SOIL AREAS MUST BE STABILIZED AS SOON AS POSSIBLE TO LIMIT SOIL EROSION BUT IN NO CASE LATER THEN 7 DAYS AFTER THE CONSTRUCTION ACTIVITY IN THAT PORTION OF THE SITE HAS TEMPORARILY OR PERMANENTLY CEASED. FOR ALL AREAS WHERE DISTURBED SOILS DRAIN TO AN IMPAIRED OR SPECIAL WATER THE EXPOSED SOIL MUST BE STABILIZED NO LATER THEN 7 DAYS AFTER THE CONSTRUCTION ACTIVITY IN THAT AREA CEASED. SEE THE IMPAIRED & SPECIAL WATERS SECTION OF THIS SWPPP FOR ADDITIONAL BMP REQUIREMENTS FOR DISTURBED AREAS THAT DRAIN TO A SPECIAL OR IMPAIRED WATER

THE NORMAL WETTED PERIMETER OF ANY TEMPORARY OR PERMANENT DRAINAGE DITCH OR SWALE THAT DRAINS WATER FROM ANY PORTION OF THE CONSTRUCTION SITE, OR DIVERTS WATER AROUND THE SITE, MUST BE STABILIZED WITHIN 200 LINEAL FEET FROM THE POINT OF DISCHARGE INTO ANY SURFACE WATER. STABILIZATION OF THE LAST 200 FEET MUST BE COMPLETED WITHIN 24 HOURS AFTER CONNECTING TO A SURFACE WATER.

PIPE CULVERT OUTLETS MUST BE PROVIDED WITH TEMPORARY OR PERMANENT ENERGY DISSIPATION WITHIN 24 HOURS AFTER CONNECTION TO A SURFACE WATER. THIS WILL INCLUDE DRAINAGE DITCHES THAT DRAIN WATER FROM ANY PORTION OF THE CONSTRUCTION SITE

THESE MANAGEMENT MEASURES FOR POLLUTION PREVENTION WILL BE STRICTLY ENFORCED.

WITHHOLDING OF PAYMENT NONCOMPLIANCE

IF THE CONTRACTOR FAILS TO INSTALL EROSION OR SEDIMENT CONTROL MEASURES ORDERED BY THE ENGINEER, THE ENGINEER MAY WITHHOLD PAYMENT FROM RELATED WORK UNTIL THE CONTROL MEASURES ARE UNDERTAKEN BY THE CONTRACTOR. WHEN THE CONTRACTOR FAILS TO CONDUCT THE QUALITY CONTROL PROGRAM, DOESNT CONDUCT THE INSPECTIONS REQUIRED IN THE NPDES PERMIT, OR FAILS TO TAKE ACTION ORDERED BY THE ENGINEER TO REMEDY EROSION OR SEDIMENT CONTROL PROBLEMS: THE ENGINEER WILL ISSUE A WRITTEN ORDER TO THE CONTRACTOR. THE CONTRACTOR SHALL RESPOND WITHIN 24 HOURS WITH SUFFICIENT PERSONNEL, EQUIPMENT AND/OR MATERIALS AND CONDUCT THE REQUIRED WORK OR BE SUBJECT TO A \$500.00 PER CALENDAR DAY DEDUCTION FOR NONCOMPLIANCE.

PROJECT CONTACTS

MPCA	NPDES	LAURAL MEZNER	218-316-3889
MPCA	EMERGENCY	STATE DUTY OFFICER	800-422-0798
DNR	NOT REQUIRED		
ANOKA COUNTY DESIGN SWPPP PREPARATION	U OF MN DESIGN OF SWPPP EXPIRES 2/20	JEFF FOSTER	763-324-3126
ANOKA COUNTY PROJECT REPRESENTATIVE	U OF MN SITE MANAGEMENT EXPIRES 2/20	HARRY GRAMS	763-324-3114
EROSION CONTROL SUPERVISOR (CONTRACTOR)			

WORKSITE DEWATERING

1. WORKSITE DEWATERING (E.G., PUMPED DISCHARGES OF COFFER DAMS AND OTHER WORK AREAS) RELATED TO THE CONSTRUCTION ACTIVITY MUST BE DISCHARGED TO A TEMPORARY OR PERMANENT SEDIMENTATION BASIN ON THE PROJECT SITE. IF THE WATER CANNOT BE DISCHARGED TO A SEDIMENTATION BASIN PRIOR TO ENTERING THE SURFACE WATER, IT MUST BE TREATED WITH THE APPROPRIATE BEST PRACTICES, SUCH THAT THE DISCHARGE DOES NOT ADVERSELY AFFECT THE RECEIVING WATER OR DOWNSSTREAM LANDOWNERS. SEDIMENT CONTROL DEVICES CAN BE BYPASSED WHEN THE DISCHARGE WATER APPEARS CLEAR.
2. STREAM DIVERSION WATER, SUCH AS A PUMPED BYPASS, SHALL BE IMMEDIATELY RETURNED TO THE ORIGINAL CHANNEL DOWNSTREAM. THIS WATER DOES NOT REQUIRE TREATMENT PRIOR TO DISCHARGE.
3. IN EITHER CASE (WORKSITE DEWATERING OR STREAM DIVERSION WATER), PRACTICES MUST BE IN PLACE TO ENSURE THAT DISCHARGE POINTS ARE ADEQUATELY PROTECTED FROM EROSION AND SCOUR.
4. ALL DRAIN PLUGS ON PUMPS SHALL BE REMOVED AND ALL DEWATERING EQUIPMENT, INCLUDING HOSES, SHALL BE DRAINED PRIOR TO TRANSPORT OFF SITE (SEE BEST PRACTICES FOR PREVENTION OF SPREAD OF AQUATIC INVASIVE SPECIES CHAPTER 1 PAGE 8).
5. FOR CONSTRUCTION DEWATERING AMOUNTS THAT EXCEED 10,000 GALLONS/ DAY OR 1 MILLION GALLONS/YR, THE PERMITTEE OR THEIR CONTRACTORS MUST SUBMIT A GP1997-0005 NOTIFICATION FORM TO THE DNR AT LEAST 5 DAYS PRIOR TO THE START OF PUMPING OPERATIONS. PRIOR AUTHORIZATION TO USE GENERAL PERMIT 1997-0005 MUST BE OBTAINED BY SUBMITTING AN APPLICATION USING THE MNDNR PERMITTING AND REPORTING SYSTEM.

CONCRETE WASHOUT

THE NPDES PERMIT REQUIRES THAT CONCRETE WASHOFF BE MANAGED ON ALL CONSTRUCTION PROJECTS. MN/DOT GUIDANCE: RECOMMENDED BEST MANAGEMENT PRACTICES FOR CONCRETE WASHOFF. THE NPDES CONSTRUCTION PERMIT REQUIRES CONCRETE WASHOFF MANAGEMENT ON EVERY PROJECT THAT USES CONCRETE VEHICLES, EQUIPMENT, TOOLS AND SURFACE PREPARATION, REQUIRING CLEANING OR WASHOFF TO REMAIN FUNCTIONAL, PROVIDE PUBLIC SAFETY OR FOR ENGINEERING PROCESS, WITH SWPPP AMENDMENTS AS NECESSARY TO PREVENT THE DISCHARGE OF CONCRETE LIQUIDS AND SOLIDS FROM MAKING CONTACT WITH SOILS UNLESS IN DEFINED, DESIGNATED AREAS USING BEST MANAGEMENT PRACTICES TO THE MAXIMUM EXTENT PRACTICABLE. ACCIDENTAL DISCHARGE: IF WASHOFF OPERATIONS MAKES ACCIDENTAL DISCHARGE TO WATERS OF THE STATE, STATE LAW REQUIRES NOTIFYING THE STATE DUTY OFFICER AND IMMEDIATELY REMOVING DISCHARGE MATERIALS AND RESTORING THE SITE. DESIGNATED AREA: ALL DESIGNATED CONCRETE WASHOFF AREAS MUST BE DETERMINED DAILY, AS NEEDED, AND THE SWPPP AMENDED TO SHOW THE LOCATIONS, AS REQUIRED BY PERMIT. SPECIAL LOCATION RESTRICTION: WASHOFF BMP MUST BE SITED MORE THAN 200 FEET FROM A DNR PUBLIC OR PERMIT LISTED SPECIAL WATER UNLESS ROBUST, REDUNDANT BEST PRACTICE PROTECTION MEASURES ARE INSTALLED WITH WASH RECOVERY MEASURES. THE DEPARTMENT RESERVES THE RIGHT TO INDICATE IN THE PLANS AND FINAL DETAILS WHERE OR WHERE NOT CONCRETE WASHOFF MAY OCCUR.

LOCATION OF SWPPP REQUIREMENTS

REQUIREMENT	TITLE	LOCATION	MN/DOT SPECIFICATION	SPECIAL PROVISION
NPDES PERMIT COMPLIANCE		SPEC	1701, 1702, & 1717	1717 (AIR, LAND & WATER) 1717 (NATIONAL POLLUTANT DISCHARGE ELIMINATION SYSTEM (NPDES) PERMIT)
CERTIFIED PERSONNEL IN EROSION AND SEDIMENT CONTROL SITE MANAGEMENT		85	1506, 1717, & 2573	1717 (AIR, LAND & WATER) 1717 (NATIONAL POLLUTANT DISCHARGE ELIMINATION SYSTEM (NPDES) PERMIT)
CHAIN OF RESPONSIBILITY	AGENCY CONTACTS	85	1506, 1717, & 2573	
PROJECT SCHEDULE / WEEKLY EROSION & SEDIMENT CONTROL SCHEDULE / COMPLETING INSPECTION / MAINTENANCE LOG	AGENCY CONTACTS	FIELD TRAILER 85 - 86	1717 & 2573	1717 (AIR, LAND & WATER) 1717 (NATIONAL POLLUTANT DISCHARGE ELIMINATION SYSTEM (NPDES) PERMIT)
SWPPP PREPARATION	AGENCY CONTACTS	85		
SITE MAP / RECEIVING WATERS / DIRECTION OF FLOW			1717	
TEMPORARY EROSION AND SEDIMENT CONTROL BMP LOCATIONS, INSTALLATION, TIMING OF INSTALLATION AND TYPE OF BMP	QUANTITY TABULATIONS	78 - 83	2573 & 2525	2575 (RAPID STABILIZATION SPECIFICATION)
ADDITIONAL TEMPORARY AND OR PERMANENT EROSION AND SEDIMENT CONTROL BMP'S NOT PROVIDED OR SHOWN IN THE PLAN		SPEC	1717, 2573, & 2575	1717 (AIR, LAND & WATER) 1717 (NATIONAL POLLUTANT DISCHARGE ELIMINATION SYSTEM (NPDES) PERMIT) 2575 (RAPID STABILIZATION SPECIFICATION)
MAINTENANCE OF EROSION AND SEDIMENT CONTROL DEVICES, REMOVAL OF TRACKED SEDIMENT, REMOVAL OF DEVICES		85 - 86	1717 & 2573	1514 (MAINTENANCE DURING CONSTRUCTION) 1717 (LAND AIR & WATER) 1717 (NATIONAL POLLUTANT DISCHARGE ELIMINATION SYSTEM (NPDES) PERMIT)
DEWATERING		85	2105.3B, & 2451.3C	DEWATERING MAY ALSO REQUIRE DNR PERMIT. DEWATERING IS ANTICIPATED FOR THIS PROJECT IN POND LOCATIONS
FINAL STABILIZATION	QUANTITY TABULATIONS EROSION CONTROL PLAN	78 - 83 85	1717, 2573, & 2575	1717 (AIR, LAND & WATER) 1717 (NATIONAL POLLUTANT DISCHARGE ELIMINATION SYSTEM (NPDES) PERMIT)
TEMPORARY EROSION AND SEDIMENT CONTROL DETAILS	QUANTITY TABULATIONS EROSION CONTROL PLAN	67 - 77	2575	2575 (RAPID STABILIZATION SPECIFICATION)
PERMANENT EROSION CONTROL DETAILS	EROSION CONTROL DETAILS	66	2575	2575 (CONTROLLING EROSION AND ESTABLISHING VEGETATION)

NO	DATE	BY	CKD	APPR	REVISION

NAME: P:\002-618-032\Plan\0261832_SW_P1.dgn 01/28/2019 6:53:34 AM

I HEREBY CERTIFY THAT THIS PLAN WAS PREPARED BY ME OR UNDER MY DIRECT SUPERVISION AND THAT I AM A DULY LICENSED PROFESSIONAL ENGINEER UNDER THE LAWS OF THE STATE OF MINNESOTA.
PRINT NAME: NICHOLAS DOBDA
SIGNATURE: *[Signature]*
DATE: 2-21-19 LICENSE NO. 49046

DRAWN BY: KT DATE: 10/24/18
DESIGN BY: JCF DATE: 10/24/18
CHECKED BY: NJD DATE: 10/24/18



**ANOKA COUNTY
HIGHWAY DEPT.**

SP 002-618-032

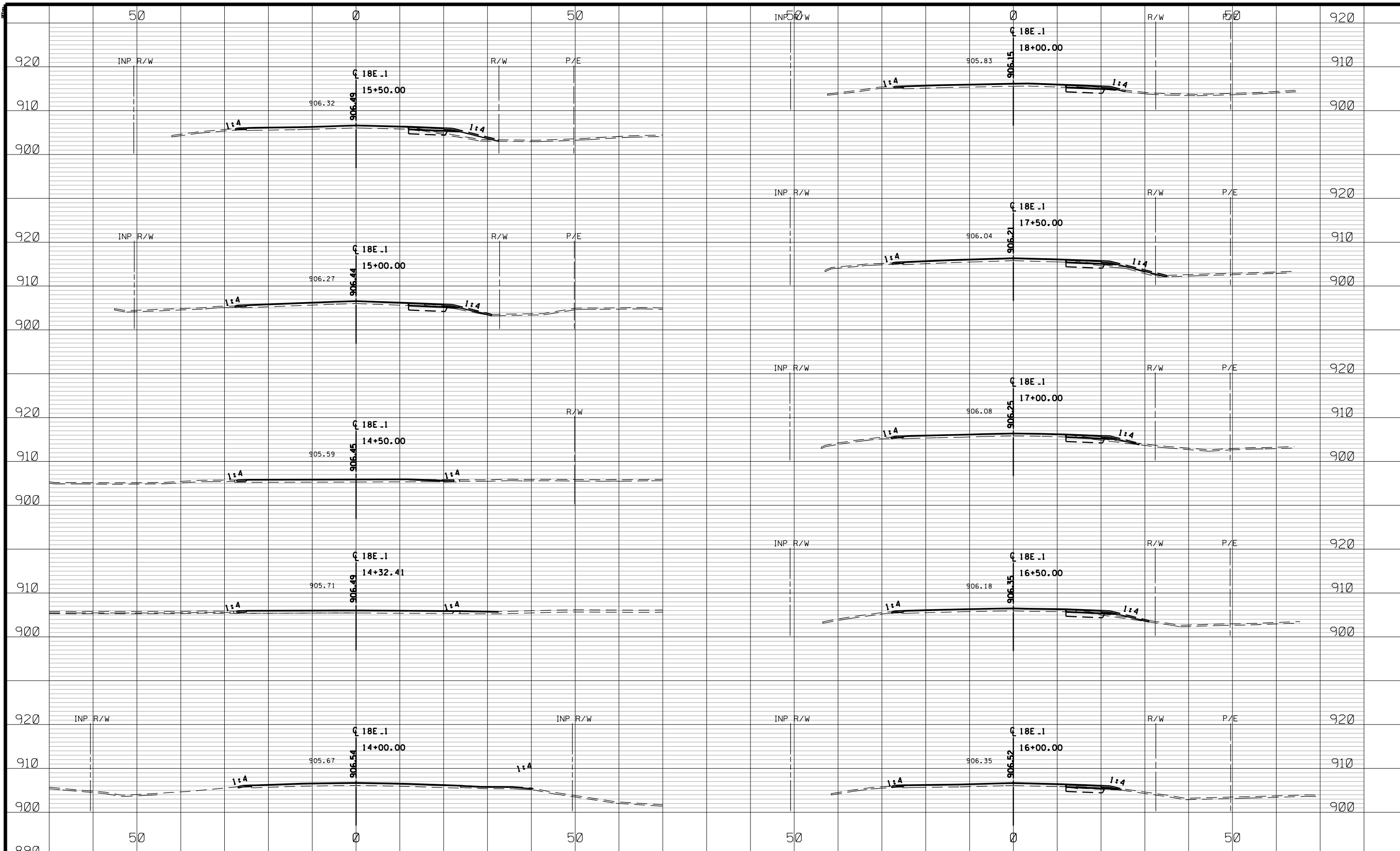

1	04/22/19	DF	JF	NJD	ADDED SUBCUT INFORMATION
NO	DATE	BY	CKD	APPR	REVISION
NAME: P:\002-618-032\Plan\0261832_XS1.dgn 04/22/2019 7:48:18 AM					

DRAWN BY KT DATE 10/24/18
 DESIGN BY JCF DATE 10/24/18
 CHECKED BY NJD DATE 10/24/18

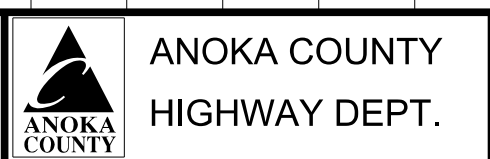

SP 002-618-032

CROSS SECTIONS
 STA 14+00.00 TO 18+00.00
 Sheet 87 of 126 Sheets

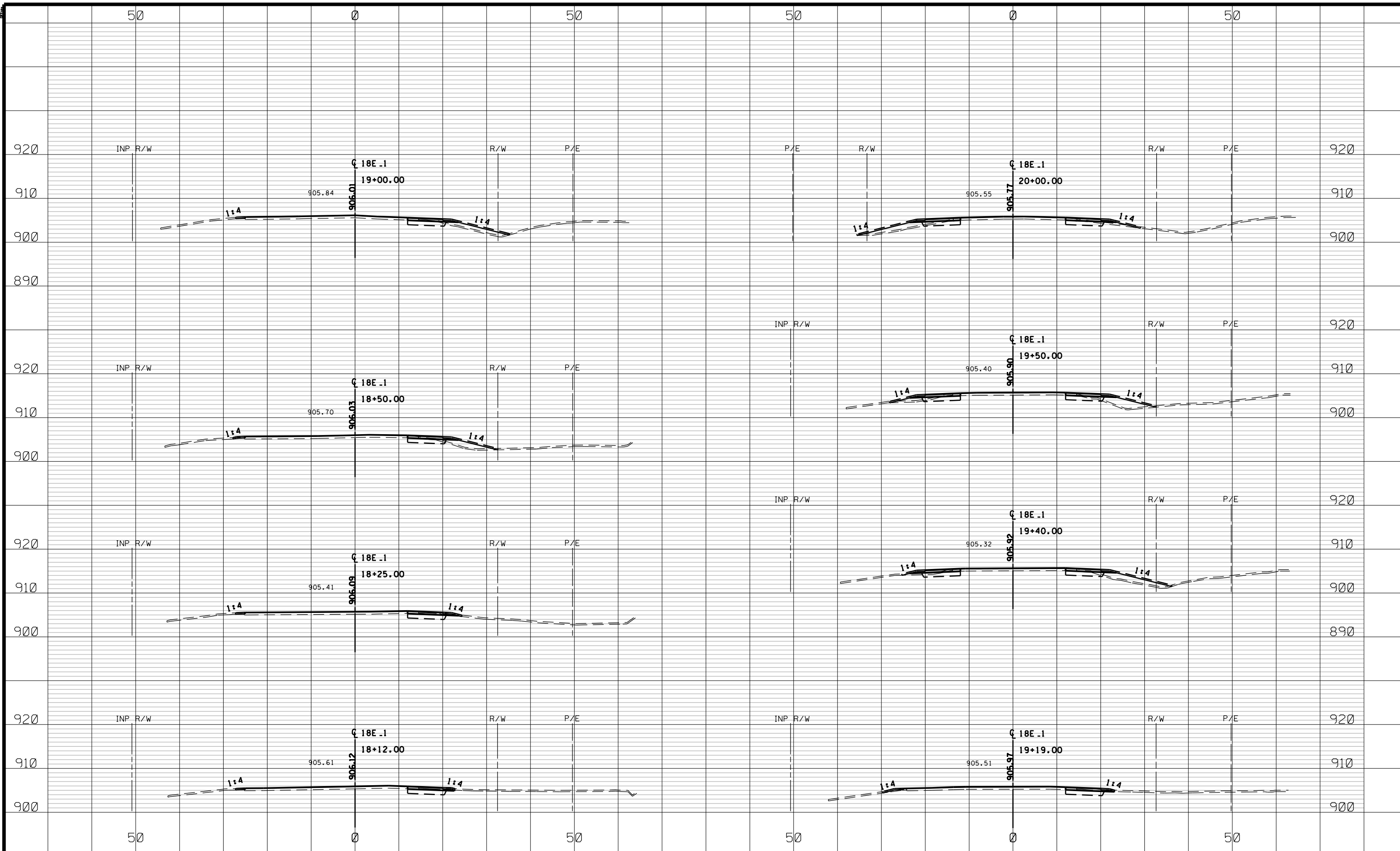

1	04/22/19	DF	JF	NJD	ADDED SUBCUT INFORMATION
NO	DATE	BY	CKD	APPR	REVISION
NAME: P:\002-618-032\Plan\0261832_XS1.dgn					04/22/2019 7:48:18 AM

DRAWN BY KT DATE 10/24/18
 DESIGN BY JCF DATE 10/24/18
 CHECKED BY NJD DATE 10/24/18

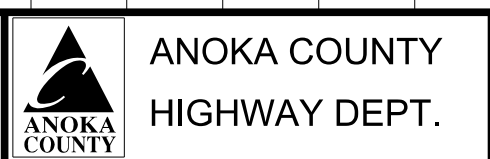

SP 002-618-032

CROSS SECTIONS
 STA 18+12.00 TO 20+00.00
 Sheet 88 of 126 Sheets

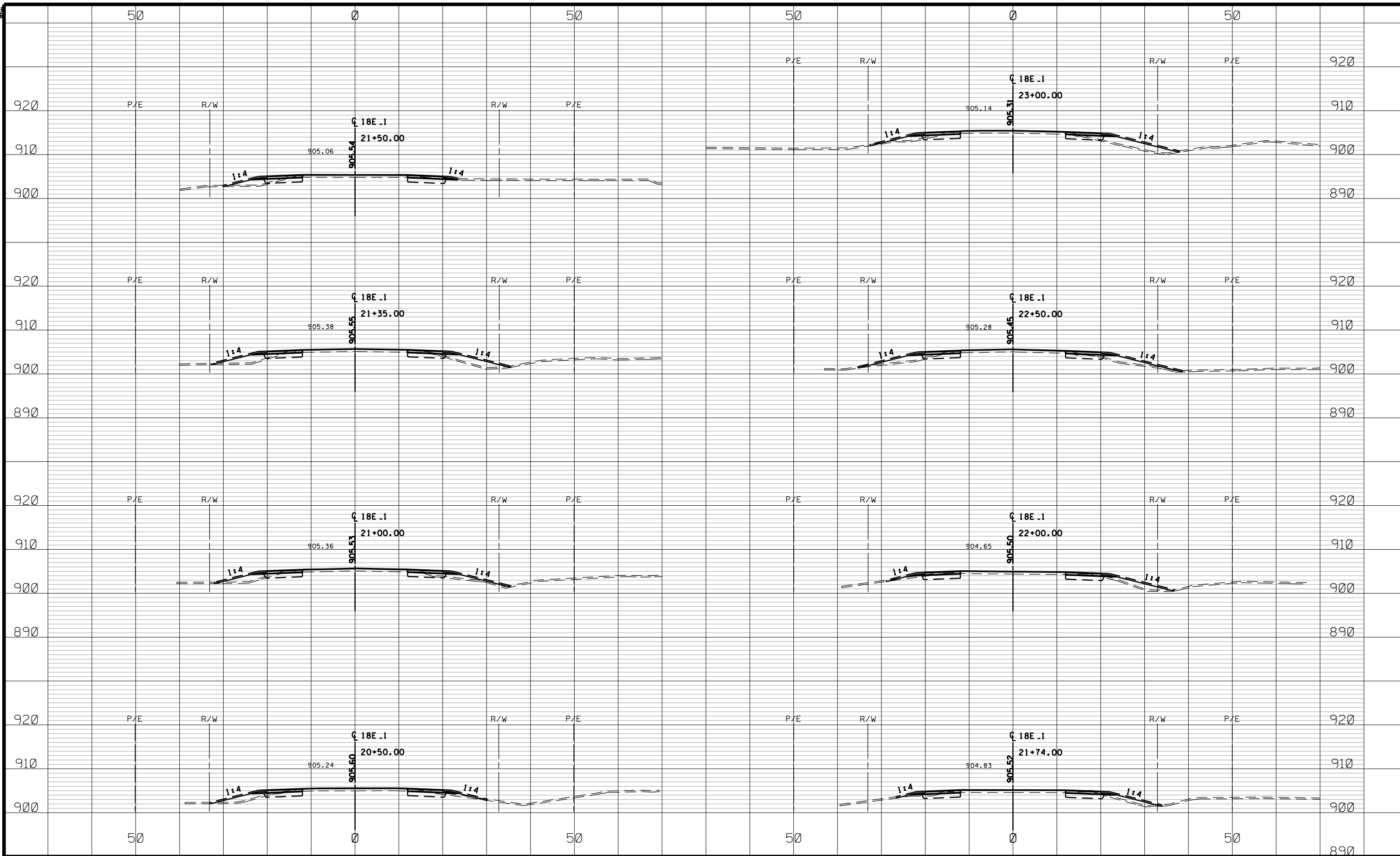

1	04/22/19	DF	JF	NJD	ADDED SUBCUT INFORMATION
NO	DATE	BY	CKD	APPR	REVISION
NAME: P:\002-618-032\Plan\0261832_XS1.dgn					04/22/2019 7:48:19 AM

DRAWN BY	KT	DATE	10/24/18
DESIGN BY	JCF	DATE	10/24/18
CHECKED BY	NJD	DATE	10/24/18

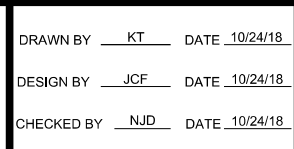

SP 002-618-032

CROSS SECTIONS
STA 20+50.00 TO 23+00.00
Sheet 89 of 126 Sheets

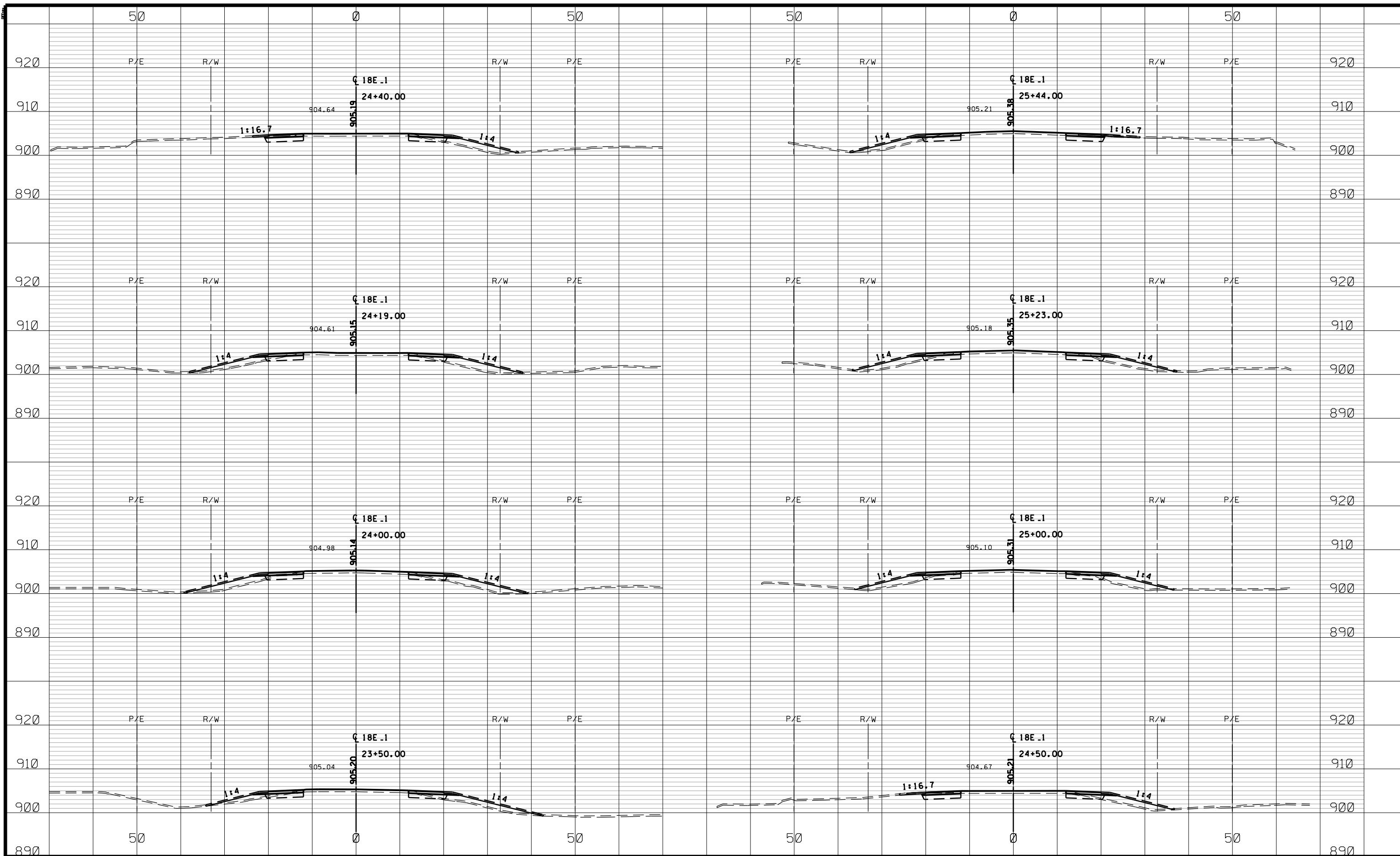

1	04/22/19	DF	JF	NJD	ADDED SUBCUT INFORMATION
NO	DATE	BY	CKD	APPR	REVISION
NAME: P:\002-618-032\Plan\0261832_XS1.dgn 04/22/2019 7:48:19 AM					

DRAWN BY KT DATE 10/24/18
 DESIGN BY JCF DATE 10/24/18
 CHECKED BY NJD DATE 10/24/18

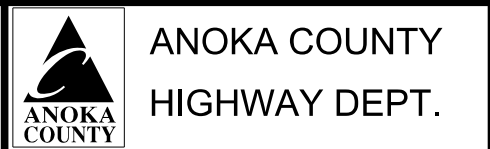

SP 002-618-032

CROSS SECTIONS
 STA 23+50.00 TO 25+44.00
 Sheet 90 of 126 Sheets

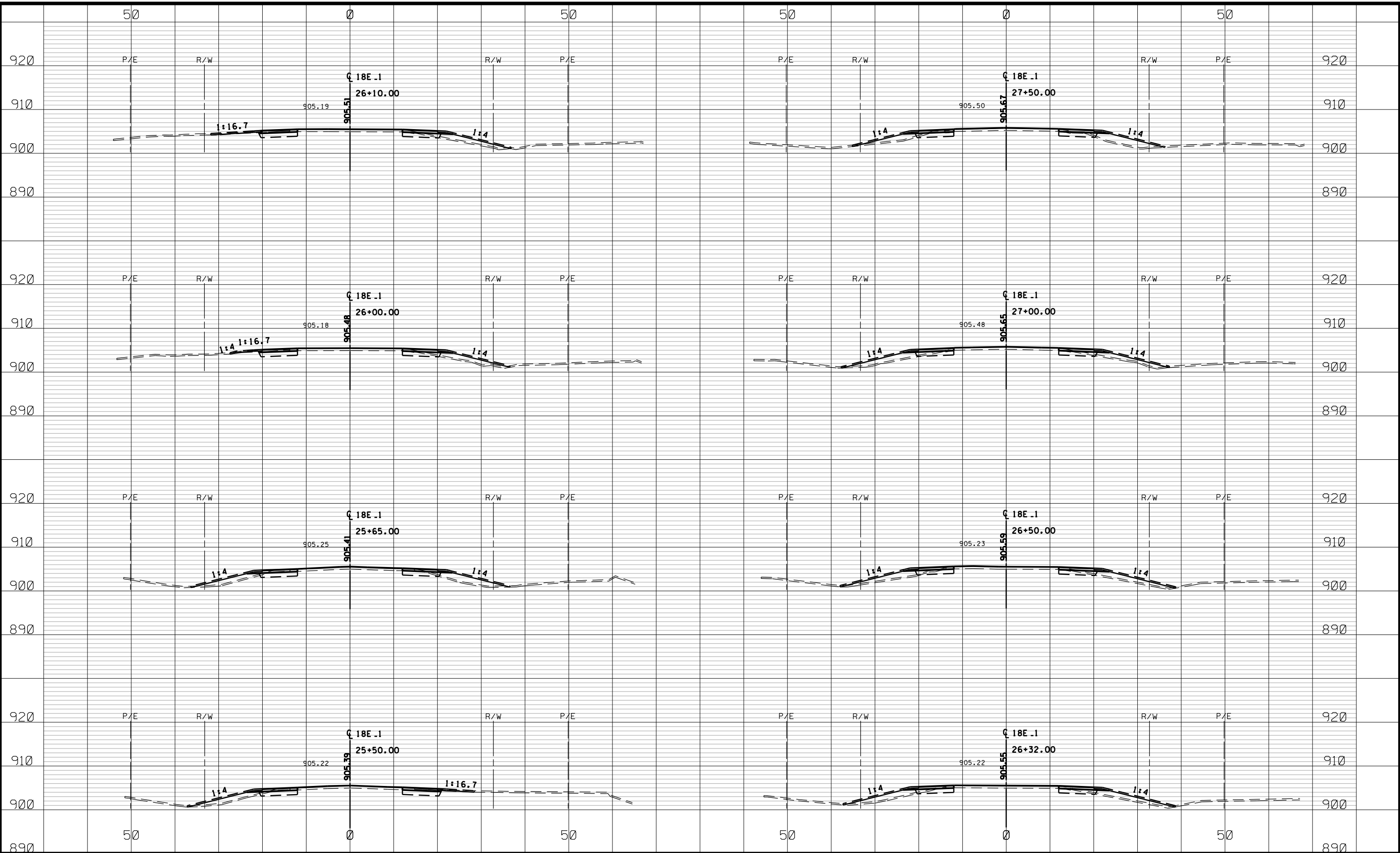

1	04/22/19	DF	JF	NJD	ADDED SUBCUT INFORMATION
NO	DATE	BY	CKD	APPR	REVISION
NAME: P:\002-618-032\Plan\0261832_XS1.dgn 04/22/2019 7:48:20 AM					

DRAWN BY	KT	DATE	10/24/18
DESIGN BY	JCF	DATE	10/24/18
CHECKED BY	NJD	DATE	10/24/18

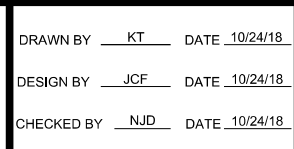

ANOKA COUNTY
HIGHWAY DEPT.

SP 002-618-032

CROSS SECTIONS
STA 25+50.00 TO 27+50.00
Sheet 91 of 126 Sheets

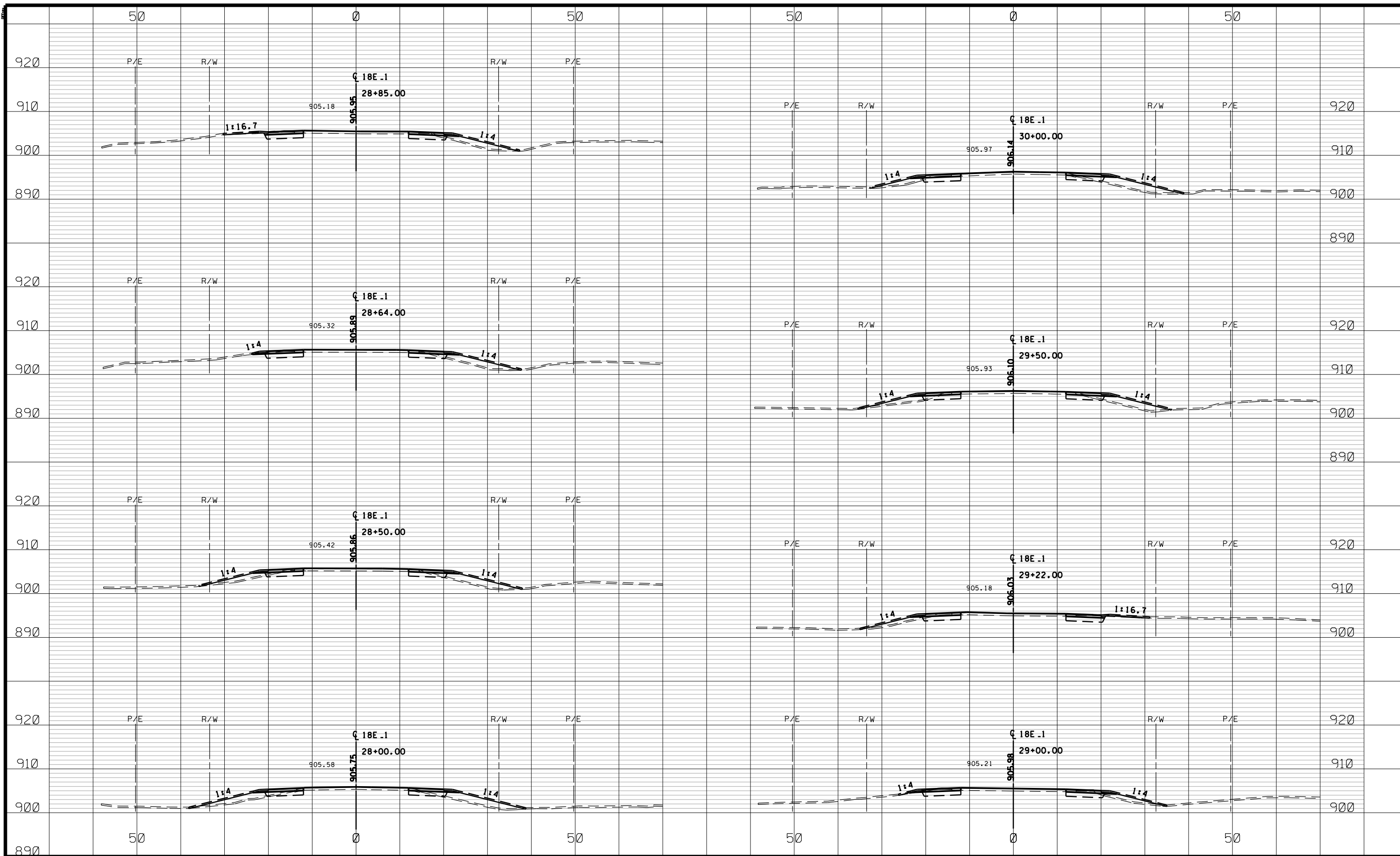

1	04/22/19	DF	JF	NJD	ADDED SUBCUT INFORMATION
NO	DATE	BY	CKD	APPR	REVISION
NAME: P:\002-618-032\Plan\0261832_XS1.dgn					
04/22/2019 7:48:20 AM					

DRAWN BY KT DATE 10/24/18
 DESIGN BY JCF DATE 10/24/18
 CHECKED BY NJD DATE 10/24/18

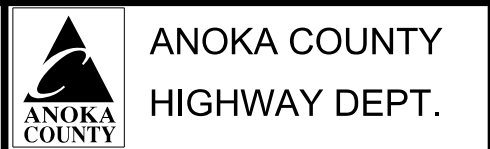

SP 002-618-032

CROSS SECTIONS
 STA 28+00.00 TO 30+00.00
 Sheet 92 of 126 Sheets

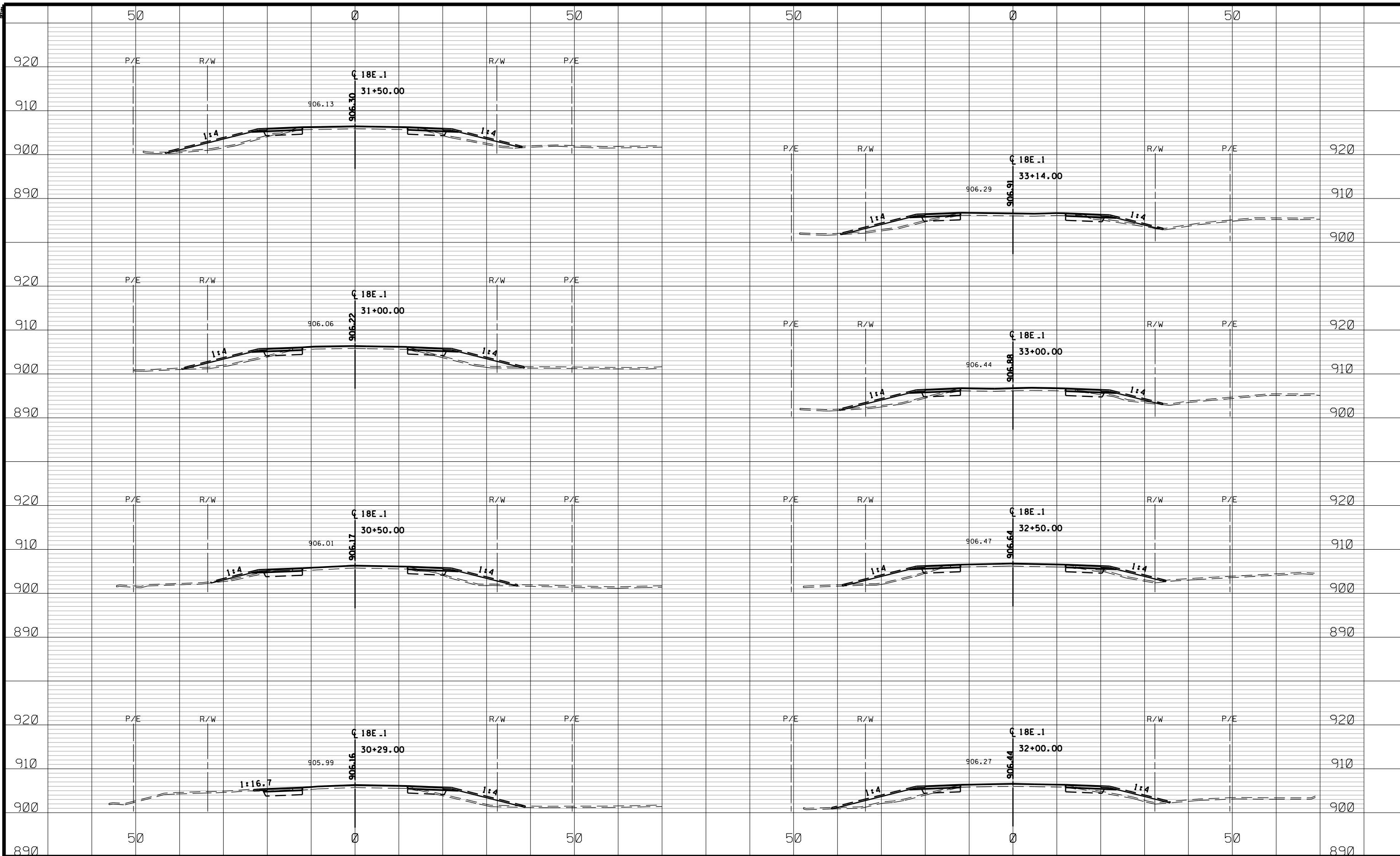

1	04/22/19	DF	JF	NJD	ADDED SUBCUT INFORMATION
NO	DATE	BY	CKD	APPR	REVISION
NAME: P:\002-618-032\Plan\0261832_XS1.dgn					
04/22/2019 7:48:20 AM					

DRAWN BY KT DATE 10/24/18
 DESIGN BY JCF DATE 10/24/18
 CHECKED BY NJD DATE 10/24/18

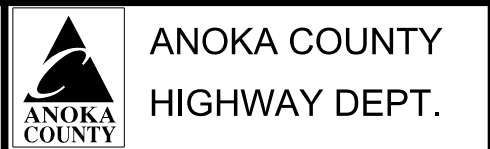

SP 002-618-032

CROSS SECTIONS
 STA 30+29.00 TO 33+14.00
 Sheet 93 of 126 Sheets

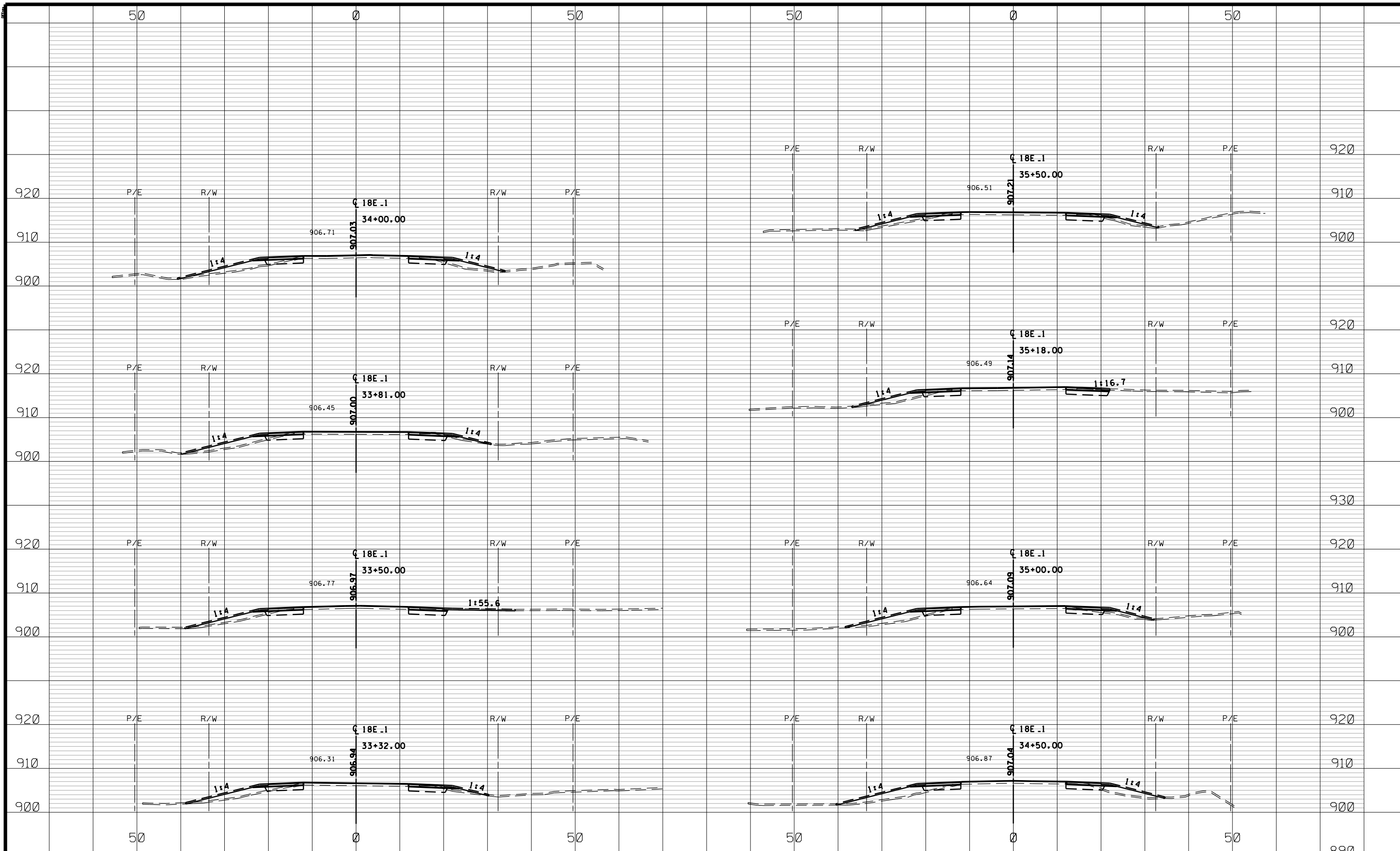

1	04/22/19	DF	JF	NJD	ADDED SUBCUT INFORMATION
NO	DATE	BY	CKD	APPR	REVISION
NAME: P:\002-618-032\Plan\0261832_XS1.dgn					
04/22/2019 7:48:21 AM					

DRAWN BY KT DATE 10/24/18
 DESIGN BY JCF DATE 10/24/18
 CHECKED BY NJD DATE 10/24/18

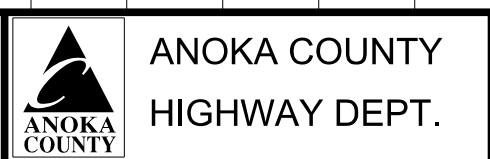

SP 002-618-032

CROSS SECTIONS
 STA 33+32.00 TO 35+50.00
 Sheet 94 of 126 Sheets

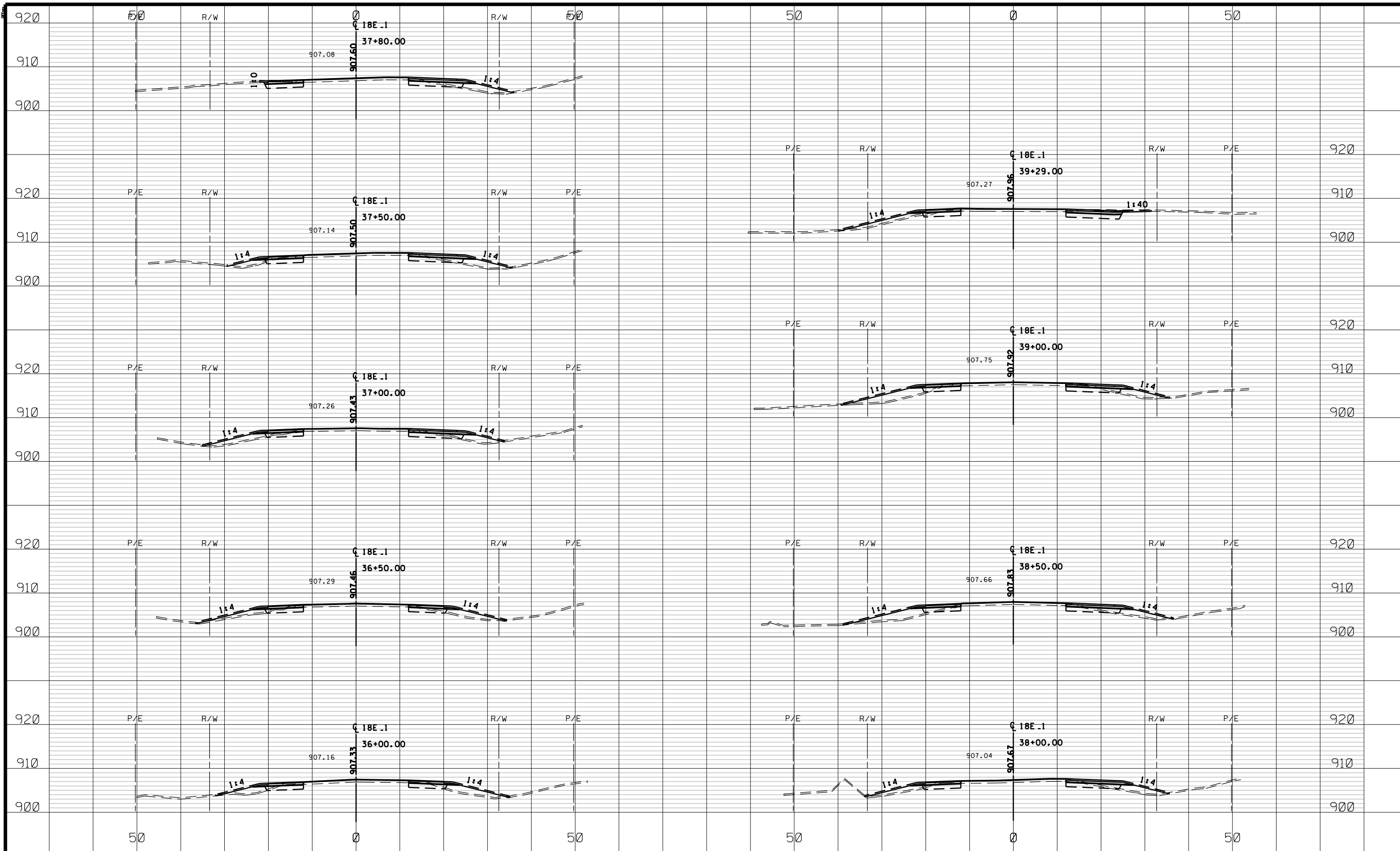

1	04/22/19	DF	JF	NJD	ADDED SUBCUT INFORMATION
NO	DATE	BY	CKD	APPR	REVISION
NAME: P:\002-618-032\Plan\0261832_XS1.dgn 04/22/2019 7:48:21 AM					

DRAWN BY KT DATE 10/24/18
 DESIGN BY JCF DATE 10/24/18
 CHECKED BY NJD DATE 10/24/18

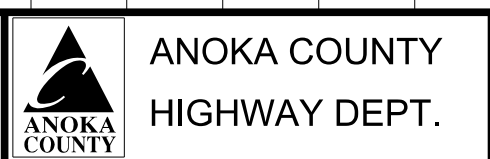

SP 002-618-032

CROSS SECTIONS
 STA 36+00.00 TO 39+29.00
 Sheet 95 of 126 Sheets

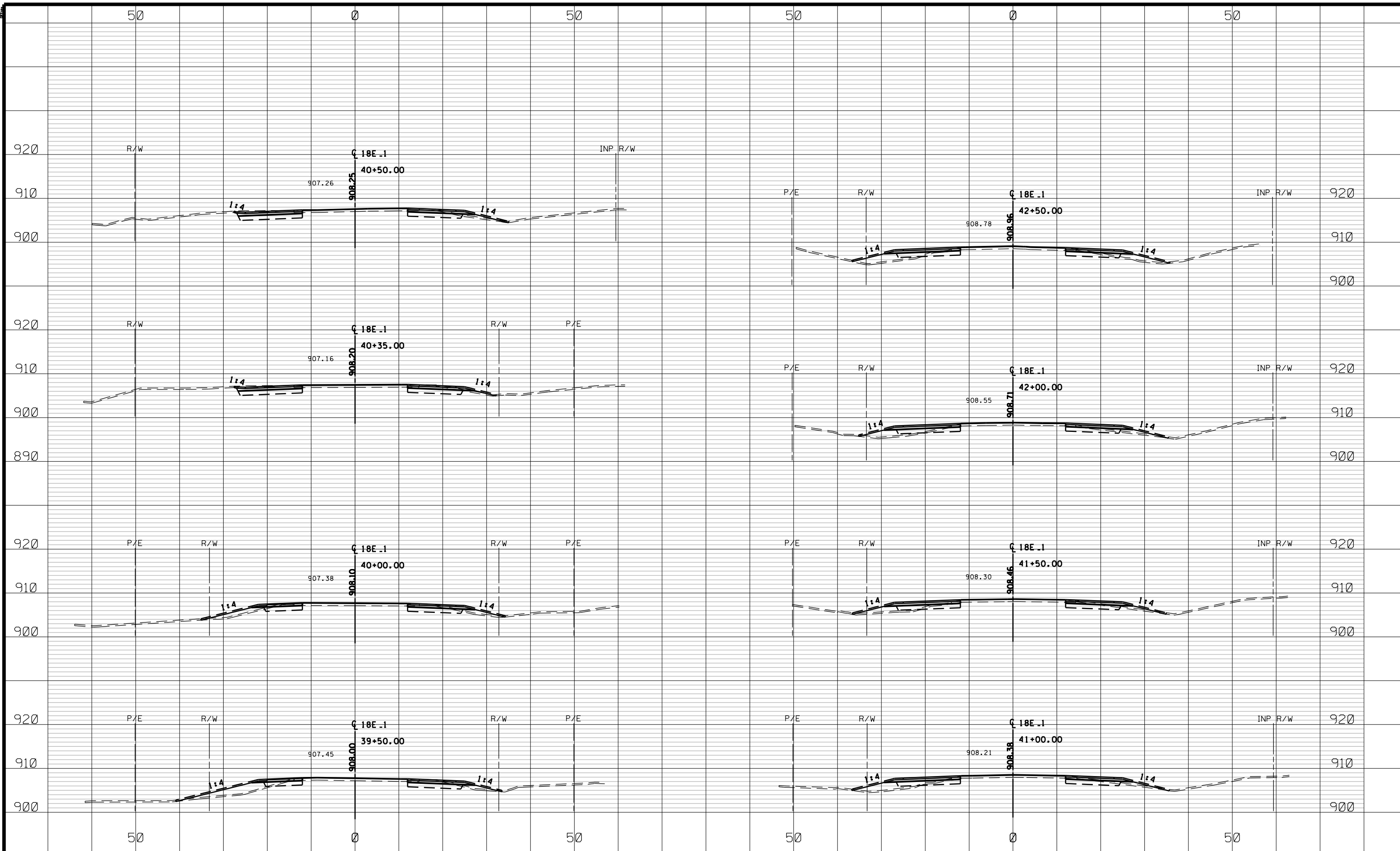

1	04/22/19	DF	JF	NJD	ADDED SUBCUT INFORMATION
NO	DATE	BY	CKD	APPR	REVISION
NAME: P:\002-618-032\Plan\0261832_XS1.dgn					04/22/2019 7:48:22 AM

DRAWN BY KT DATE 10/24/18
 DESIGN BY JCF DATE 10/24/18
 CHECKED BY NJD DATE 10/24/18

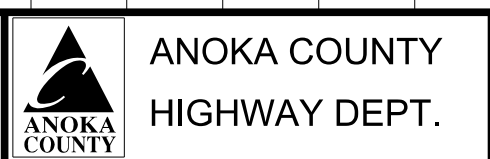

SP 002-618-032

CROSS SECTIONS
 STA 39+50.00 TO 42+50.00
 Sheet 96 of 126 Sheets

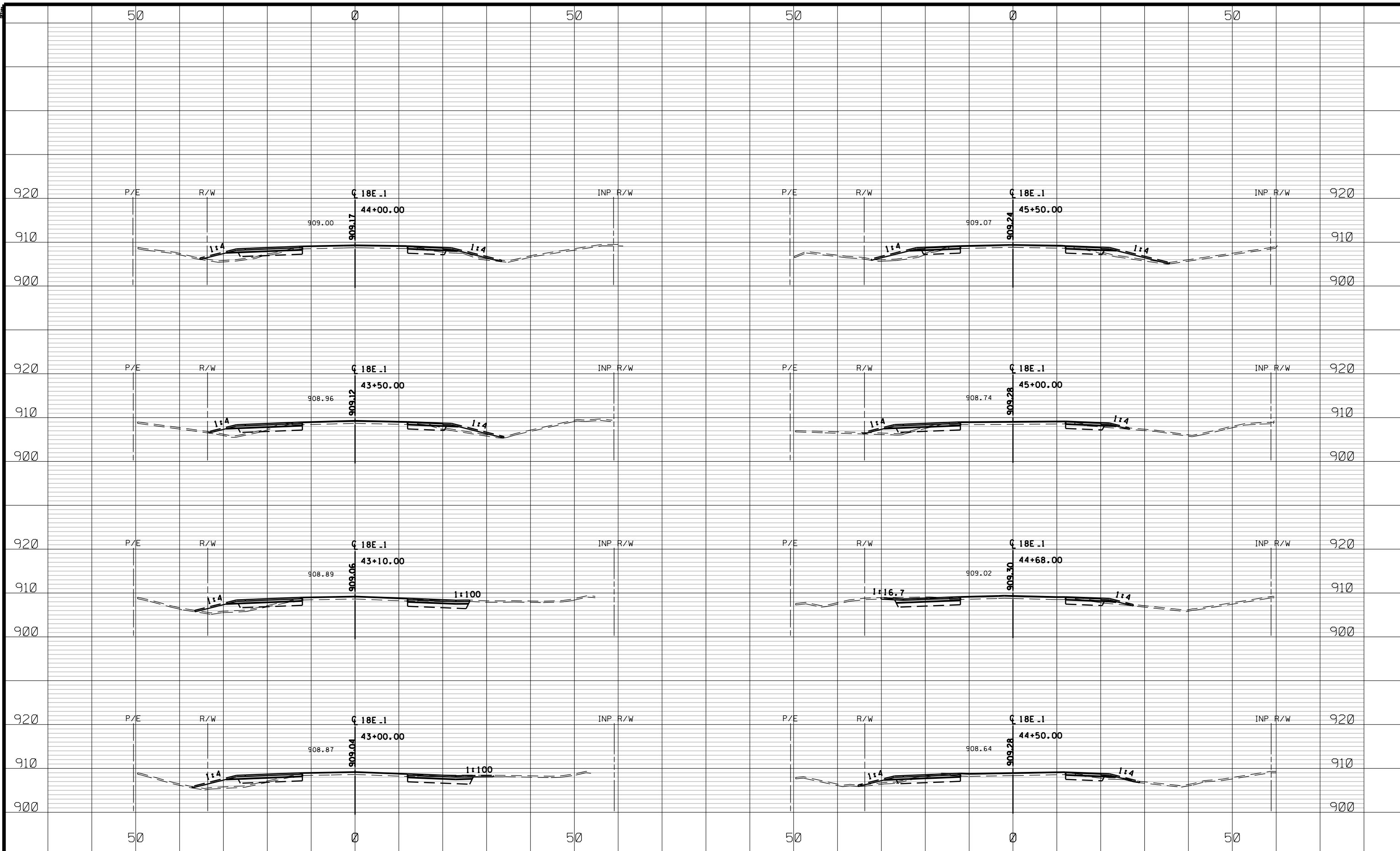

1	04/22/19	DF	JF	NJD	ADDED SUBCUT INFORMATION
NO	DATE	BY	CKD	APPR	REVISION
NAME: P:\002-618-032\Plan\0261832_XS1.dgn					04/22/2019 7:48:22 AM

DRAWN BY KT DATE 10/24/18
 DESIGN BY JCF DATE 10/24/18
 CHECKED BY NJD DATE 10/24/18

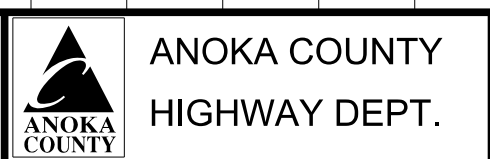

SP 002-618-032

CROSS SECTIONS
 STA 43+00.00 TO 45+00.00
 Sheet 97 of 126 Sheets

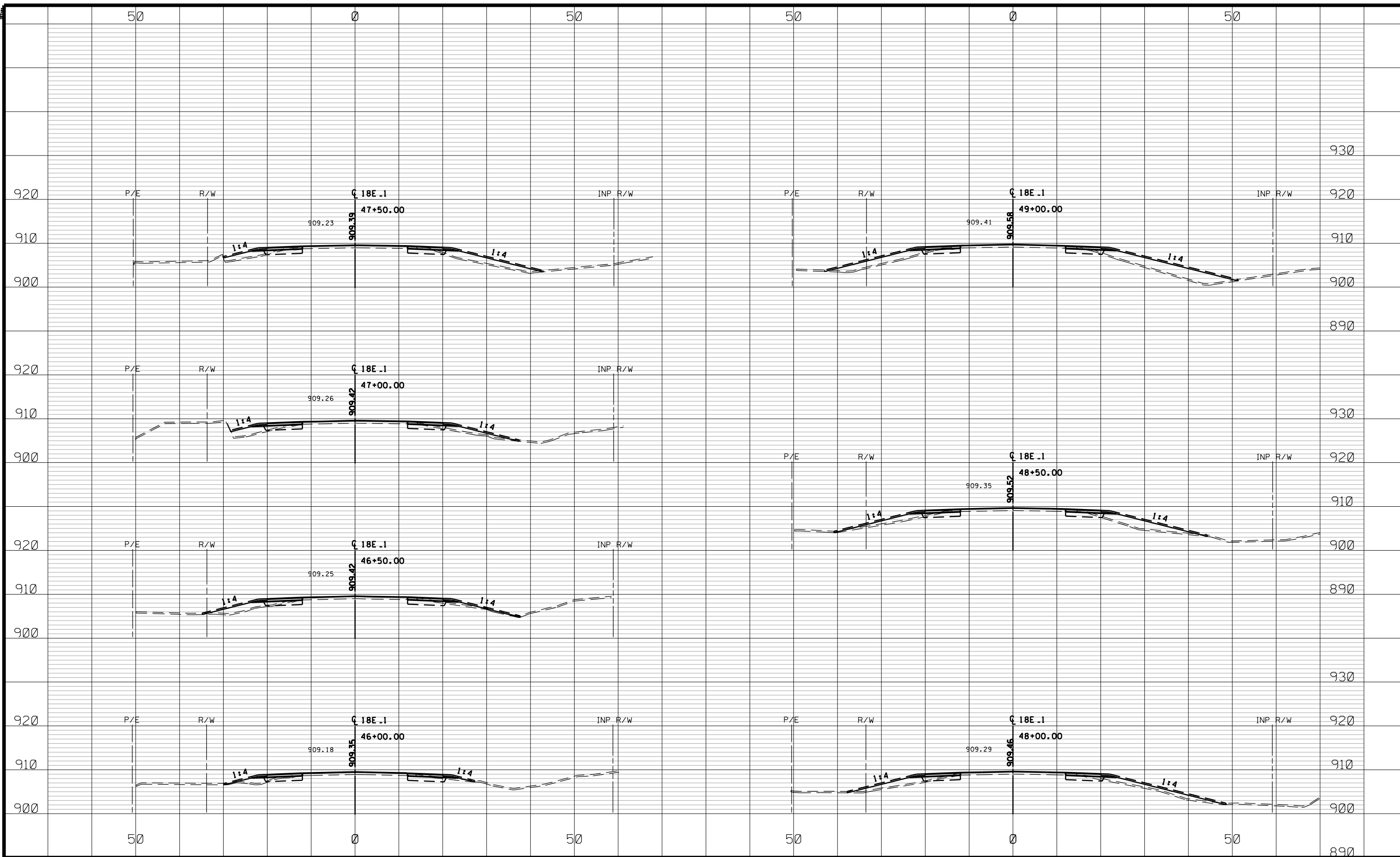

1	04/22/19	DF	JF	NJD	ADDED SUBCUT INFORMATION
NO	DATE	BY	CKD	APPR	REVISION
NAME: P:\002-618-032\Plan\0261832_XS1.dgn 04/22/2019 7:48:22 AM					

DRAWN BY KT DATE 10/24/18
 DESIGN BY JCF DATE 10/24/18
 CHECKED BY NJD DATE 10/24/18

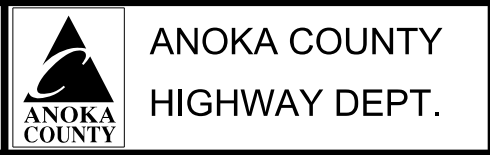

SP 002-618-032

CROSS SECTIONS
 STA 46+00.00 TO 49+00.00
 Sheet 98 of 126 Sheets

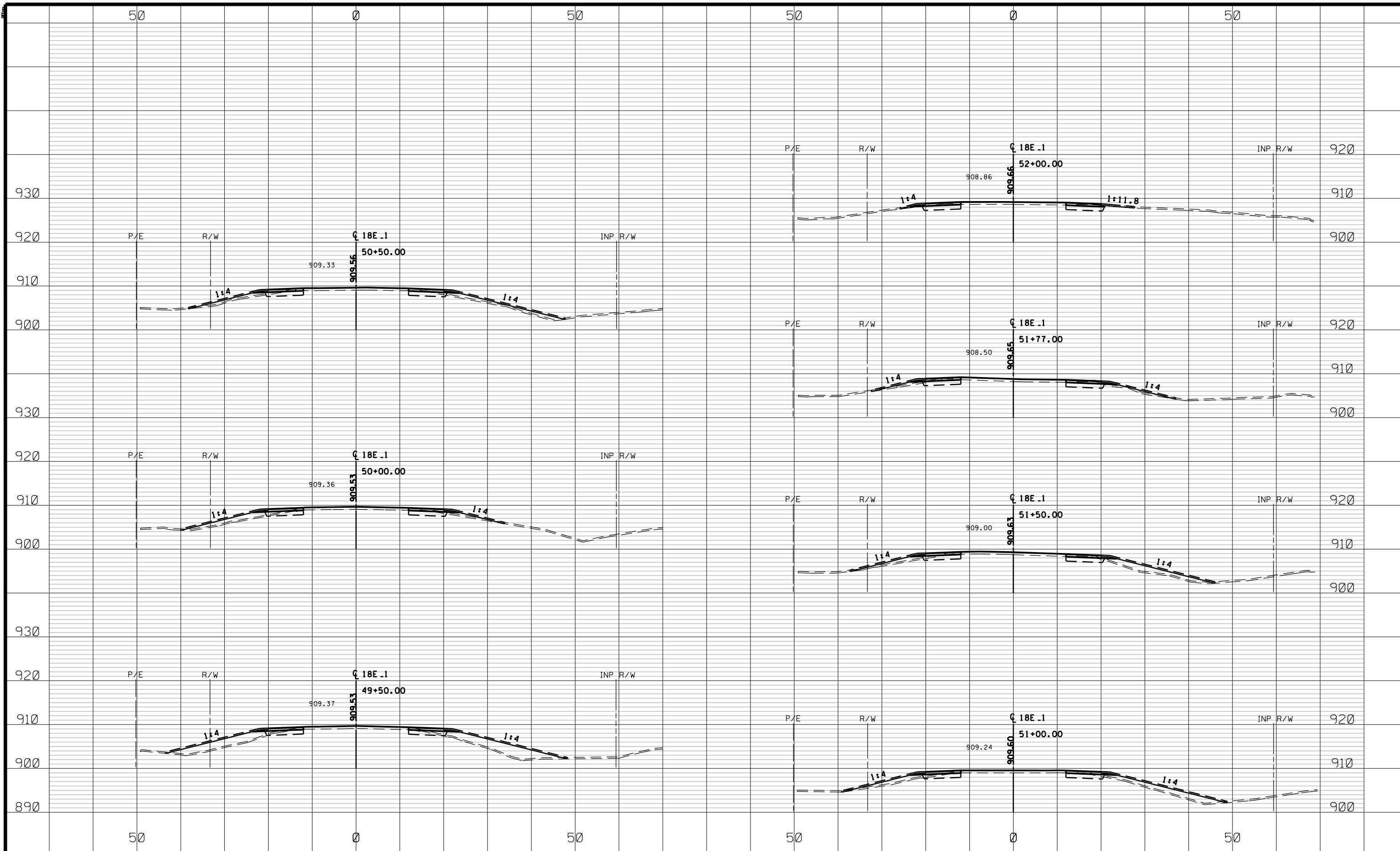

1	04/22/19	DF	JF	NJD	ADDED SUBCUT INFORMATION
NO	DATE	BY	CKD	APPR	REVISION
NAME: P:\002-618-032\Plan\0261832_XS1.dgn					
04/22/2019 7:48:23 AM					

DRAWN BY KT DATE 10/24/18
 DESIGN BY JCF DATE 10/24/18
 CHECKED BY NJD DATE 10/24/18

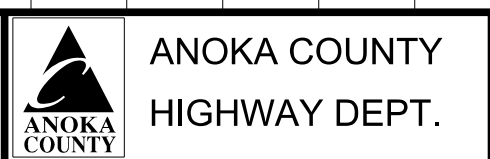

SP 002-618-032
 CROSS SECTIONS
 STA 49+50.00 TO 52+00.00
 Sheet 99 of 126 Sheets

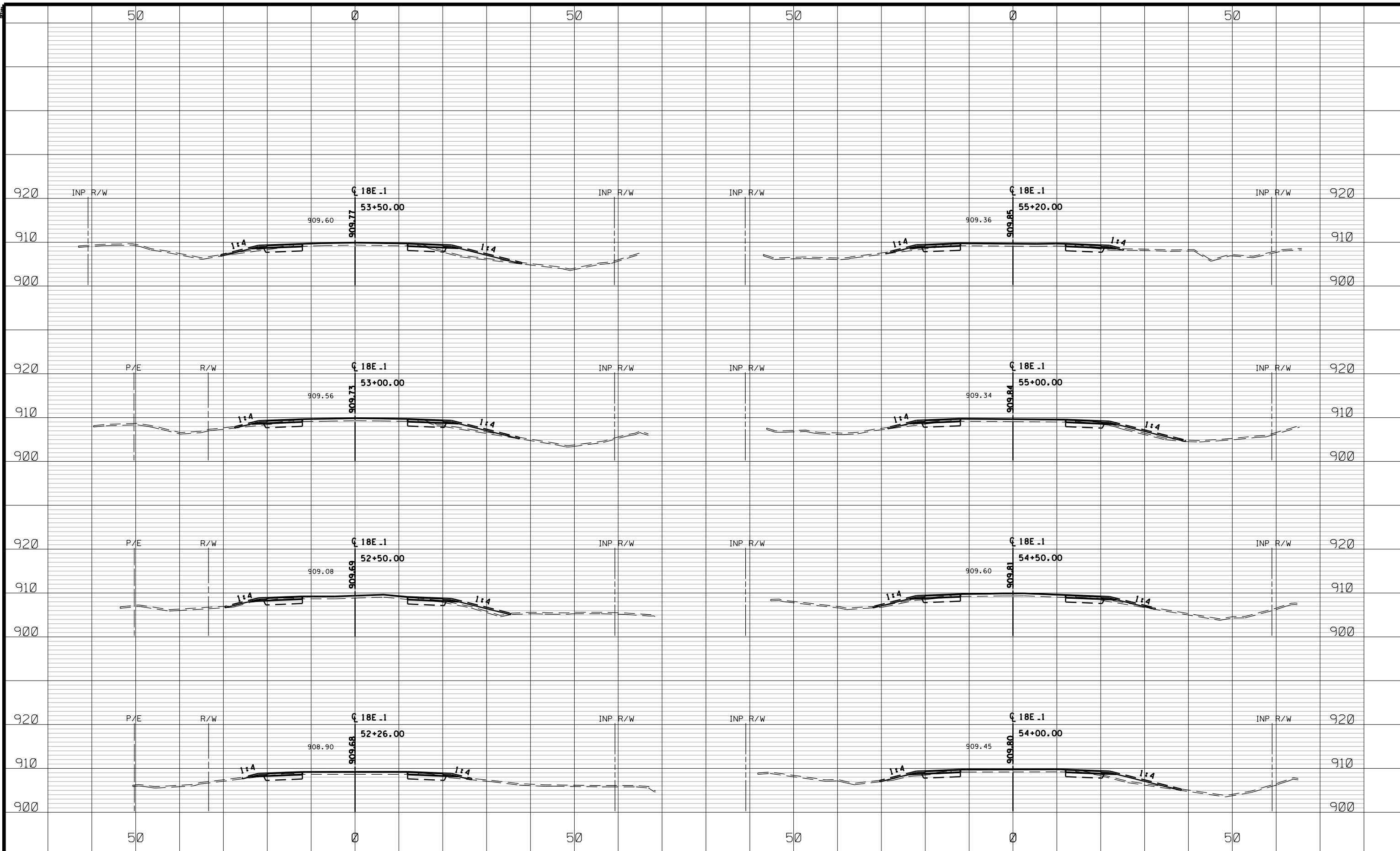

1	04/22/19	DF	JF	NJD	ADDED SUBCUT INFORMATION
NO	DATE	BY	CKD	APPR	REVISION
NAME: P:\002-618-032\Plan\0261832_XS1.dgn					
04/22/2019 7:48:23 AM					

DRAWN BY KT DATE 10/24/18
 DESIGN BY JCF DATE 10/24/18
 CHECKED BY NJD DATE 10/24/18

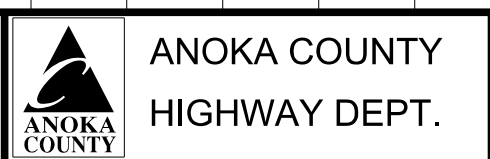

SP 002-618-032

CROSS SECTIONS
 STA 52+26.00 TO 55+20.00
 Sheet 100 of 126 Sheets

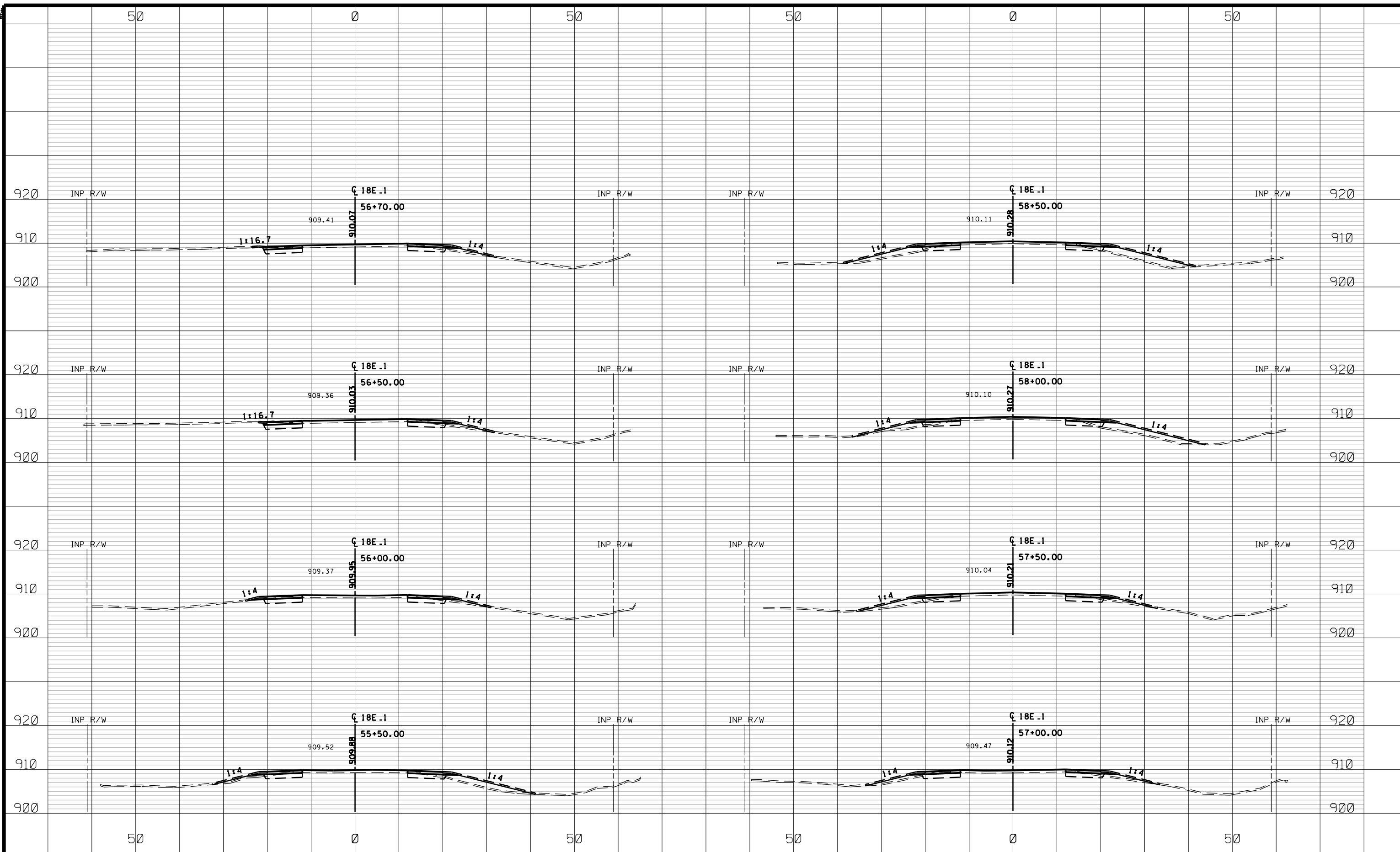

1	04/22/19	DF	JF	NJD	ADDED SUBCUT INFORMATION
NO	DATE	BY	CKD	APPR	REVISION
NAME: P:\002-618-032\Plan\0261832_XS1.dgn					04/22/2019 7:48:24 AM

DRAWN BY KT DATE 10/24/18
 DESIGN BY JCF DATE 10/24/18
 CHECKED BY NJD DATE 10/24/18

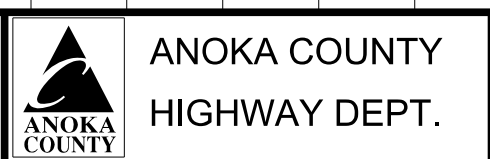

SP 002-618-032

CROSS SECTIONS
 STA 55+50.00 TO 58+50.00
 Sheet 101 of 126 Sheets

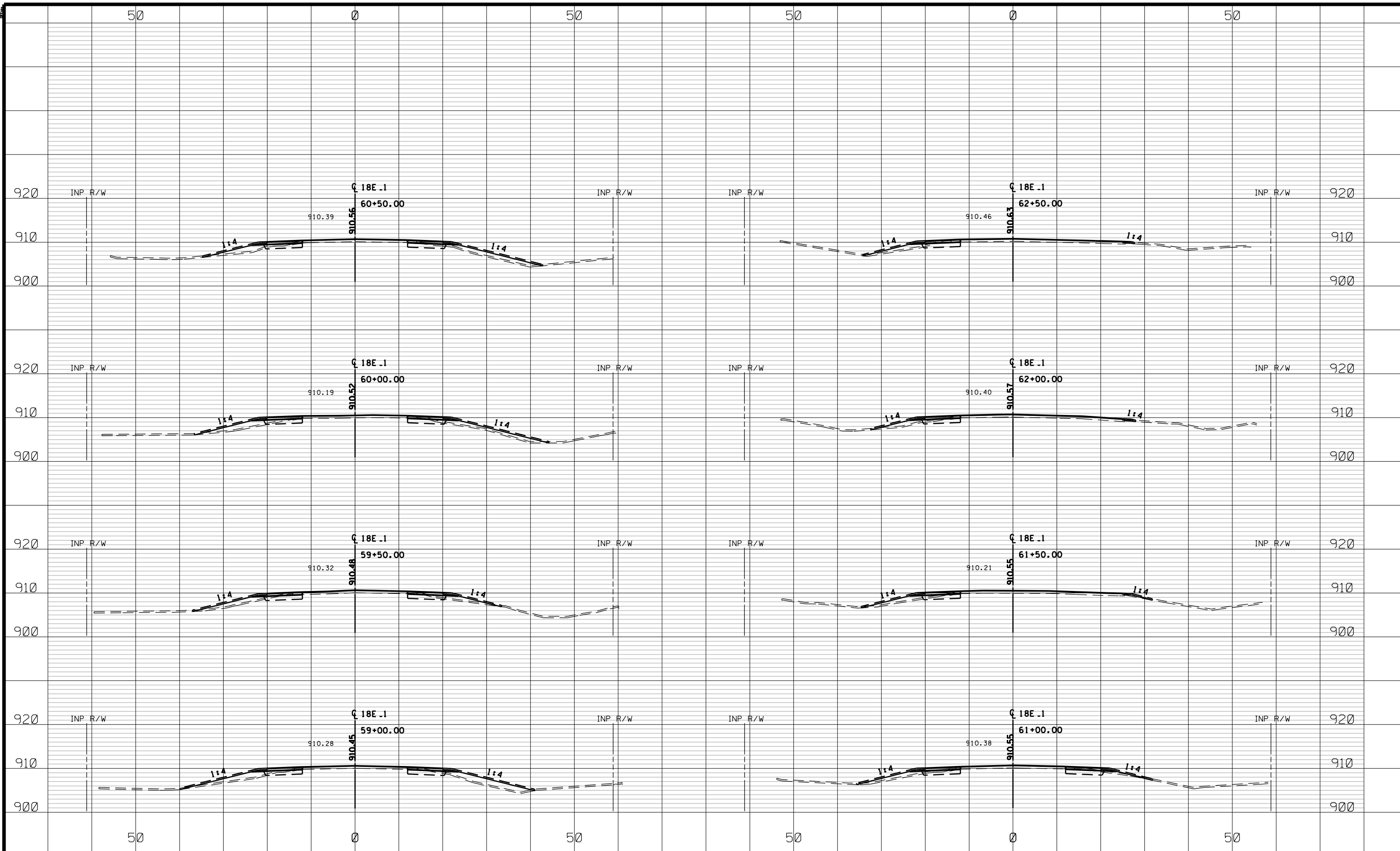

1	04/22/19	DF	JF	NJD	ADDED SUBCUT INFORMATION
NO	DATE	BY	CKD	APPR	REVISION
NAME: P:\002-618-032\Plan\0261832_XS1.dgn 04/22/2019 7:48:24 AM					

DRAWN BY KT DATE 10/24/18
 DESIGN BY JCF DATE 10/24/18
 CHECKED BY NJD DATE 10/24/18

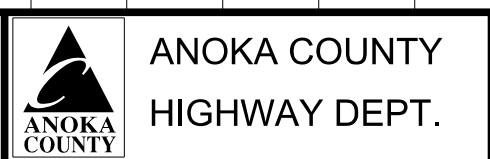

SP 002-618-032

CROSS SECTIONS
 STA 59+00.00 TO 62+50.00
 Sheet 102 of 126 Sheets

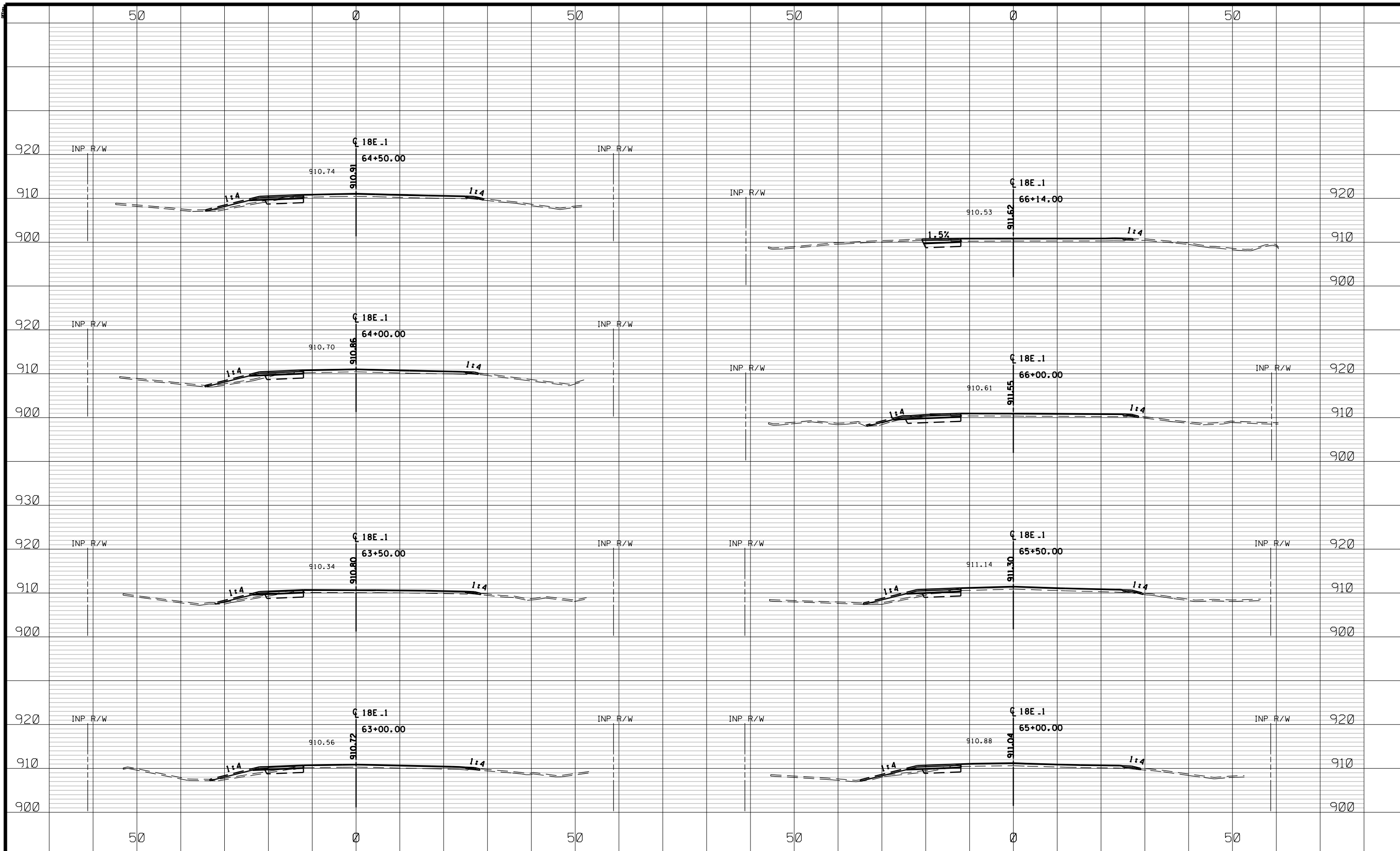

1	04/22/19	DF	JF	NJD	ADDED SUBCUT INFORMATION
NO	DATE	BY	CKD	APPR	REVISION
NAME: P:\002-618-032\Plan\0261832_XS1.dgn					
04/22/2019 7:48:24 AM					

DRAWN BY KT DATE 10/24/18
 DESIGN BY JCF DATE 10/24/18
 CHECKED BY NJD DATE 10/24/18

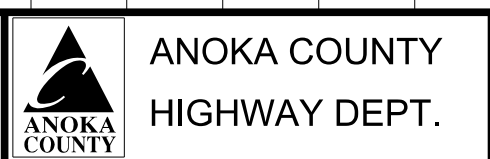

SP 002-618-032

CROSS SECTIONS
 STA 63+00.00 TO 66+14.00
 Sheet 103 of 126 Sheets

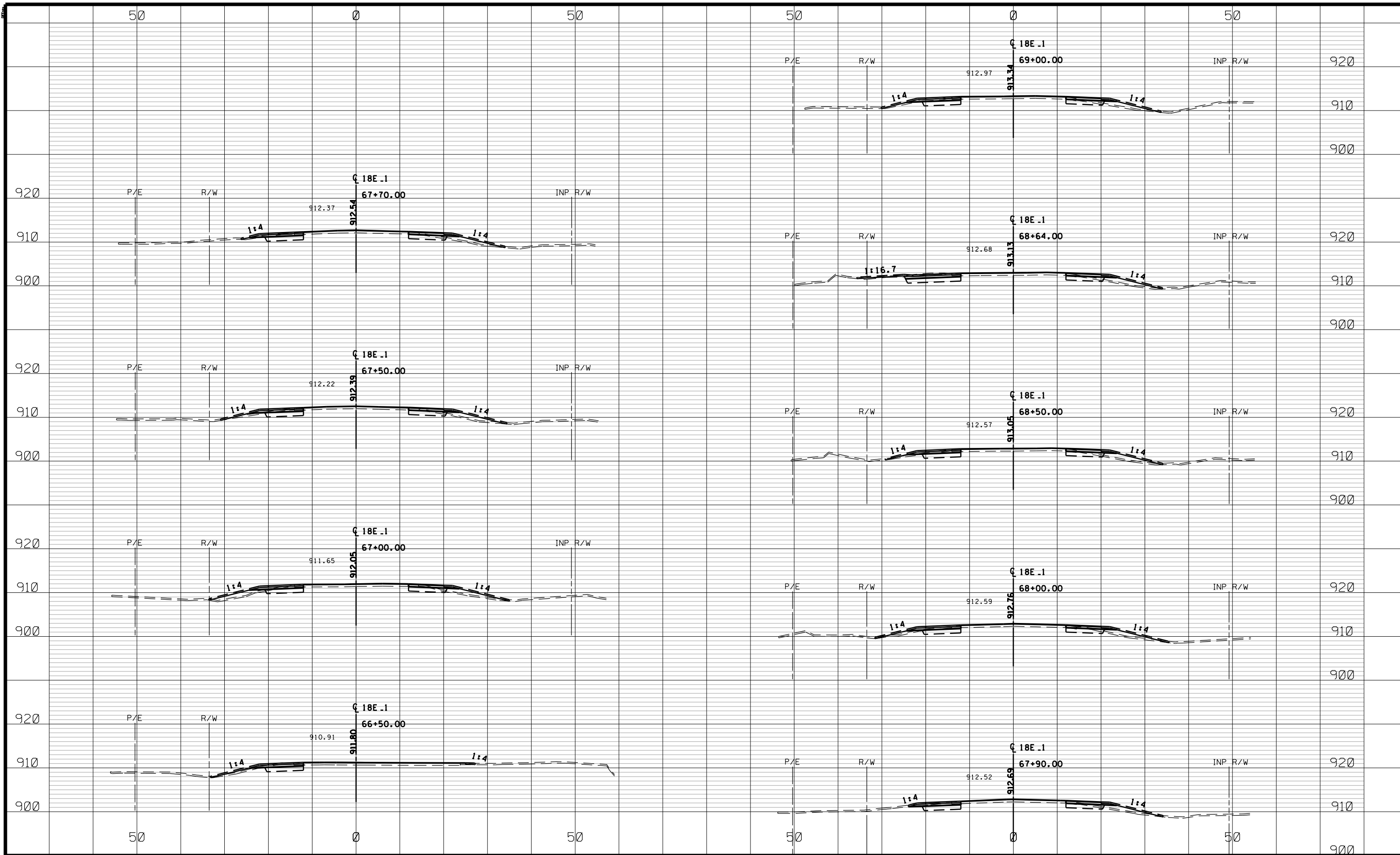

1	04/22/19	DF	JF	NJD	ADDED SUBCUT INFORMATION
NO	DATE	BY	CKD	APPR	REVISION
NAME: P:\002-618-032\Plan\0261832_XS1.dgn 04/22/2019 7:48:25 AM					

DRAWN BY KT DATE 10/24/18
 DESIGN BY JCF DATE 10/24/18
 CHECKED BY NJD DATE 10/24/18

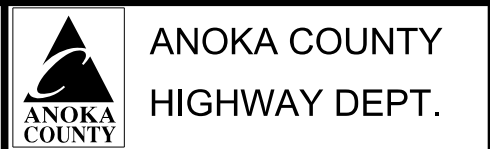

SP 002-618-032

CROSS SECTIONS
 STA 66+50.00 TO 69+00.00
 Sheet 104 of 126 Sheets

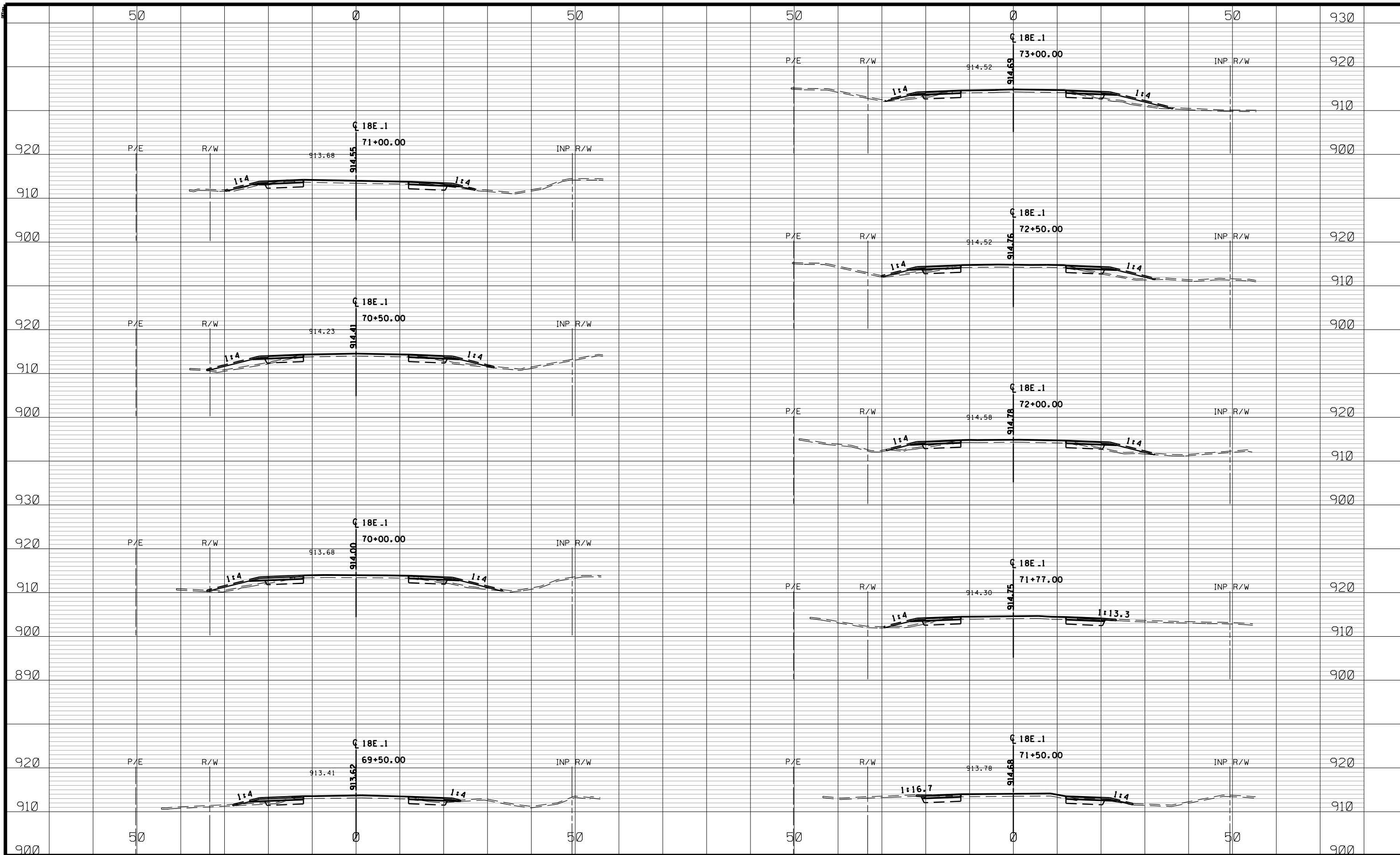

1	04/22/19	DF	JF	NJD	ADDED SUBCUT INFORMATION
NO	DATE	BY	CKD	APPR	REVISION
NAME: P:\002-618-032\Plan\0261832_XS1.dgn 04/22/2019 7:48:25 AM					

DRAWN BY KT DATE 10/24/18
 DESIGN BY JCF DATE 10/24/18
 CHECKED BY NJD DATE 10/24/18

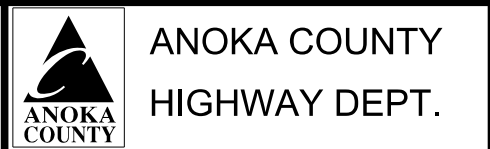

SP 002-618-032

CROSS SECTIONS
 STA 69+50.00 TO 73+00.00
 Sheet 105 of 126 Sheets

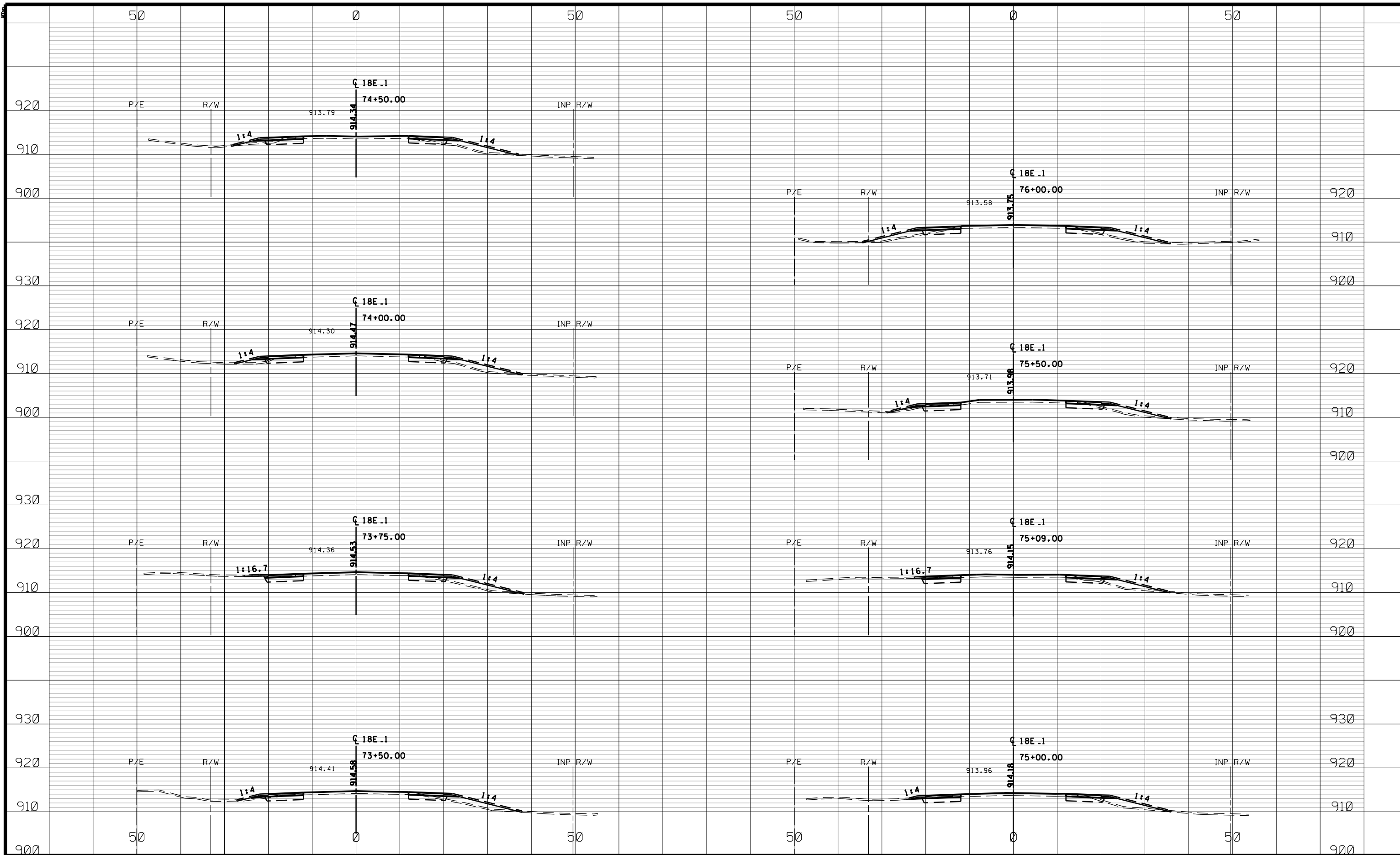

1	04/22/19	DF	JF	NJD	ADDED SUBCUT INFORMATION
NO	DATE	BY	CKD	APPR	REVISION
NAME: P:\002-618-032\Plan\0261832_XS1.dgn 04/22/2019 7:48:26 AM					

DRAWN BY KT DATE 10/24/18
 DESIGN BY JCF DATE 10/24/18
 CHECKED BY NJD DATE 10/24/18

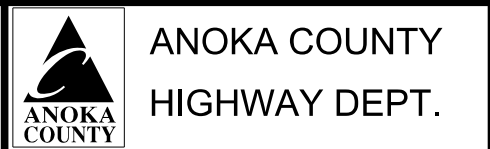

SP 002-618-032

CROSS SECTIONS
 STA 73+50.00 TO 76+00.00
 Sheet 106 of 126 Sheets

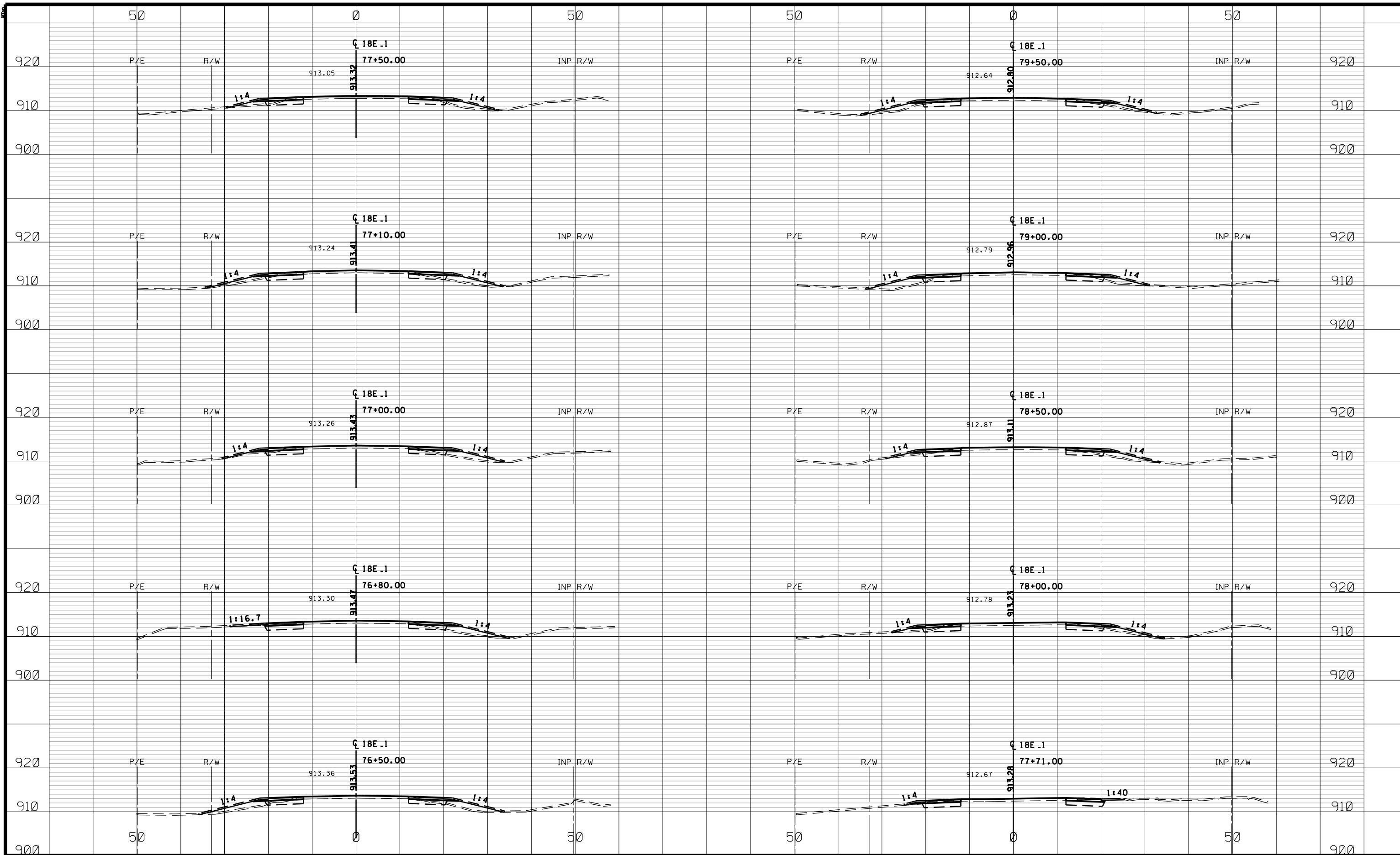

1	04/22/19	DF	JF	NJD	ADDED SUBCUT INFORMATION
NO	DATE	BY	CKD	APPR	REVISION
NAME: P:\002-618-032\Plan\0261832_XS1.dgn					04/22/2019 7:48:26 AM

DRAWN BY KT DATE 10/24/18
 DESIGN BY JCF DATE 10/24/18
 CHECKED BY NJD DATE 10/24/18

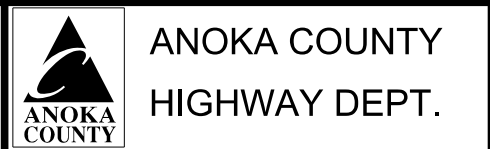

SP 002-618-032

CROSS SECTIONS
 STA 76+50.00 TO 79+50.00
 Sheet 107 of 126 Sheets

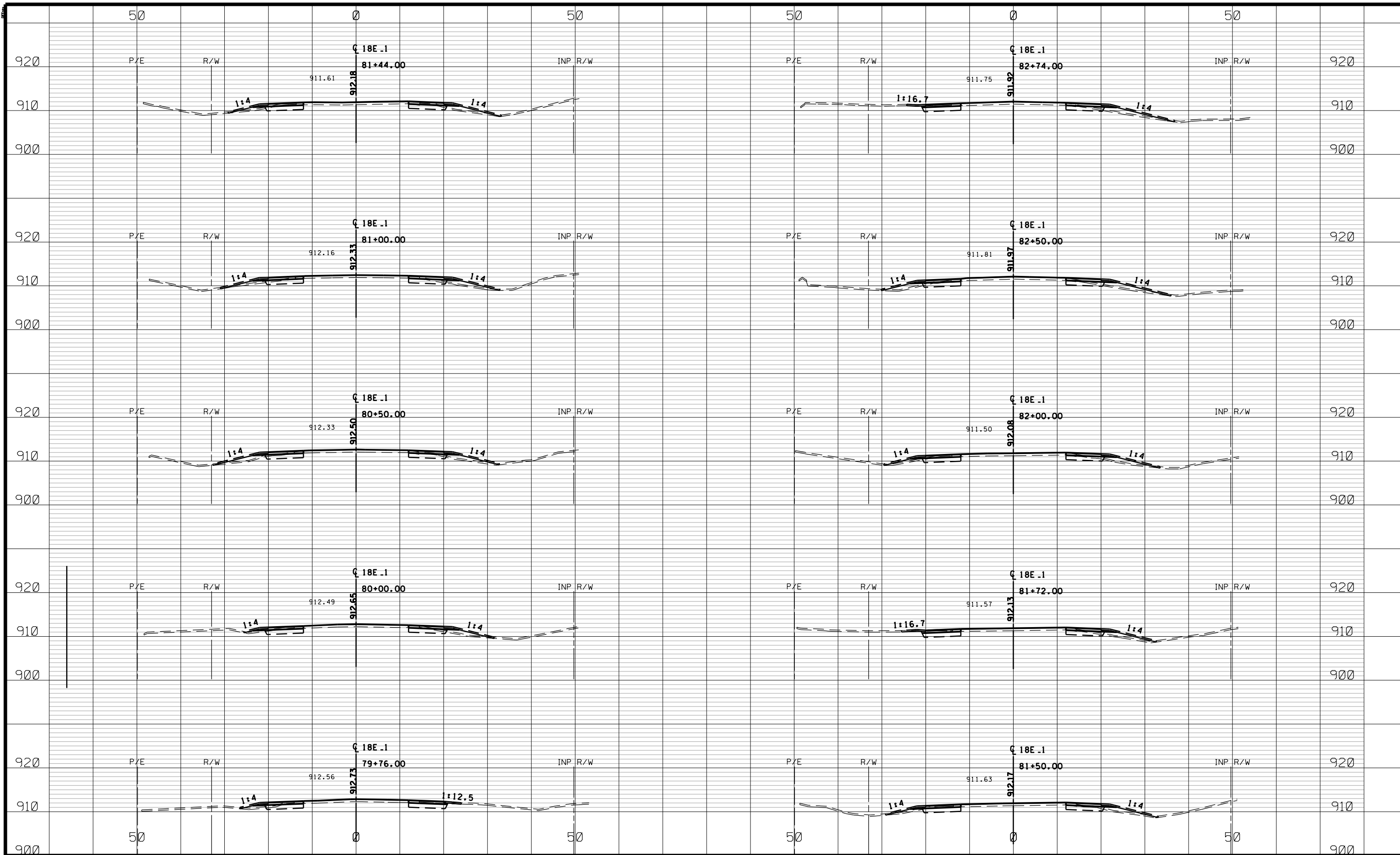

1	04/22/19	DF	JF	NJD	ADDED SUBCUT INFORMATION
NO	DATE	BY	CKD	APPR	REVISION
NAME: P:\002-618-032\Plan\0261832_XS1.dgn					04/22/2019 7:48:26 AM

DRAWN BY KT DATE 10/24/18
 DESIGN BY JCF DATE 10/24/18
 CHECKED BY NJD DATE 10/24/18

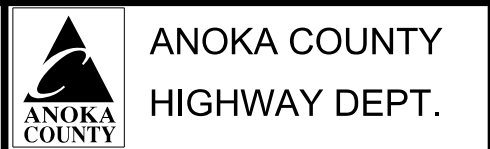

SP 002-618-032

CROSS SECTIONS
 STA 79+76.00 TO 82+74.00
 Sheet 108 of 126 Sheets

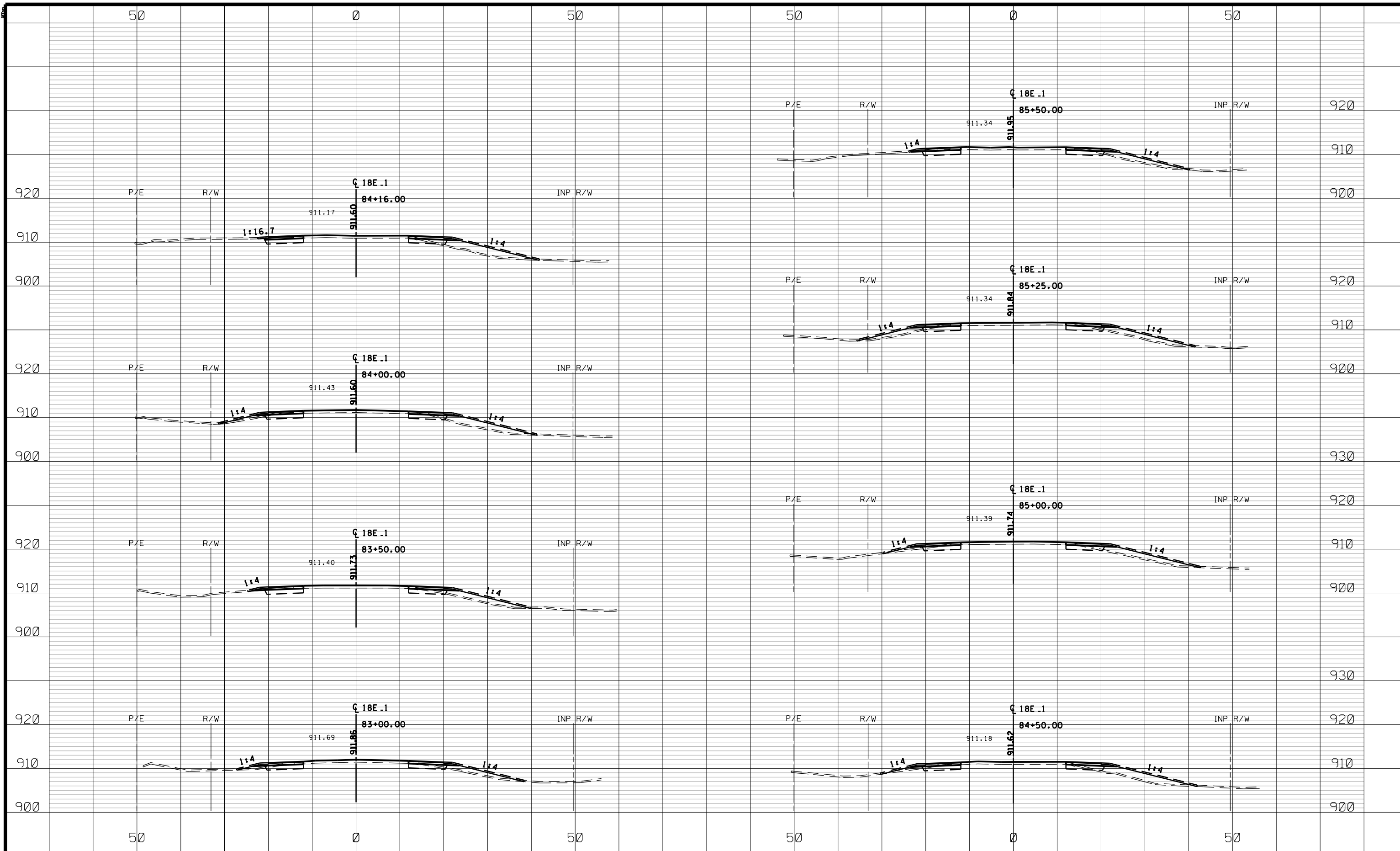

1	04/22/19	DF	JF	NJD	ADDED SUBCUT INFORMATION
NO	DATE	BY	CKD	APPR	REVISION
NAME: P:\002-618-032\Plan\0261832_XS1.dgn 04/22/2019 7:48:27 AM					

DRAWN BY KT DATE 10/24/18
 DESIGN BY JCF DATE 10/24/18
 CHECKED BY NJD DATE 10/24/18

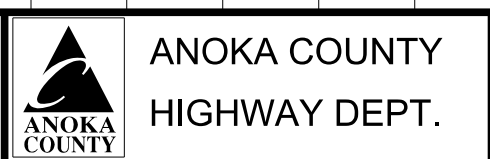

SP 002-618-032

CROSS SECTIONS
 STA 83+00.00 TO 85+00.00
 Sheet 109 of 126 Sheets

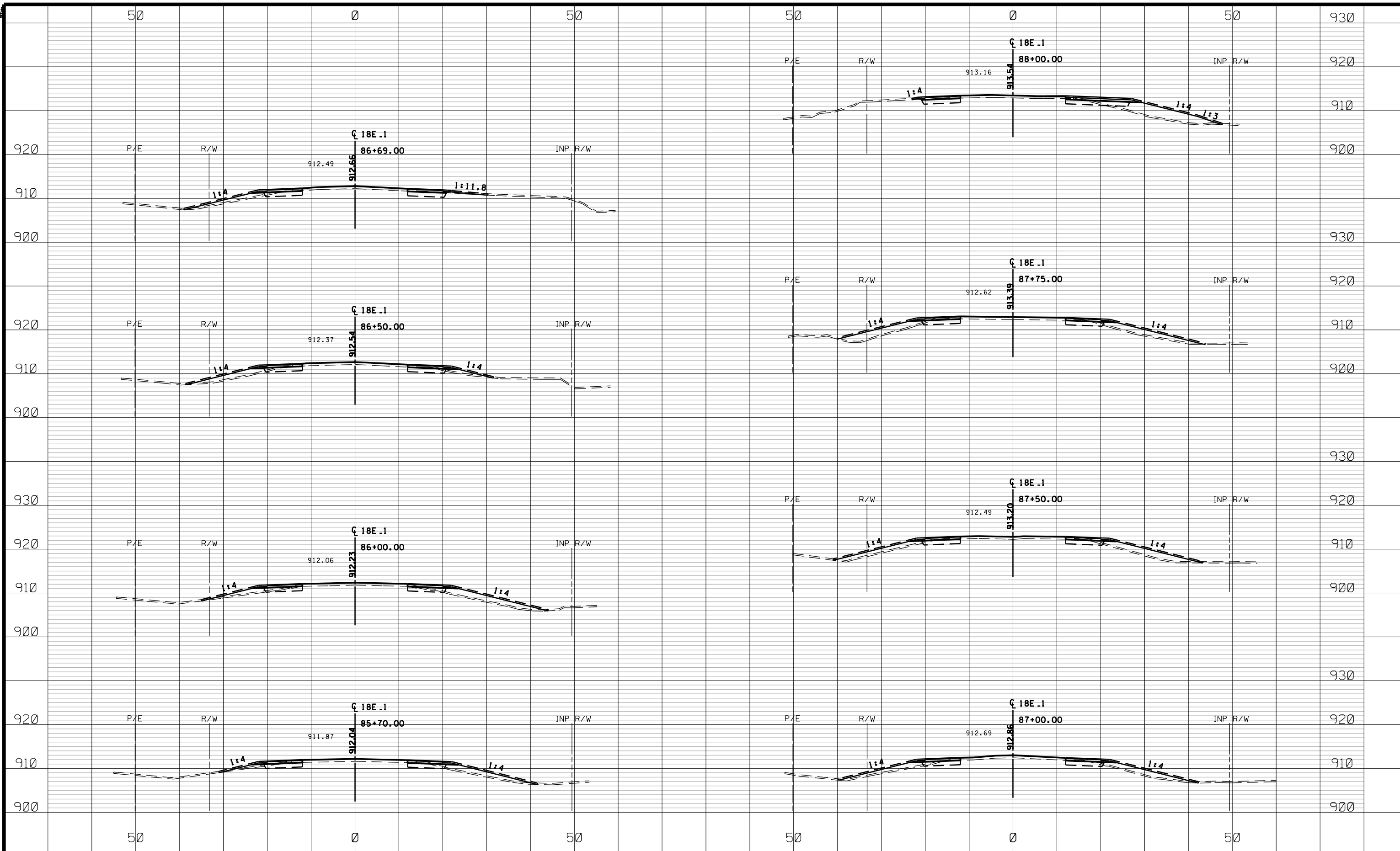

1	04/22/19	DF	JF	NJD	ADDED SUBCUT INFORMATION
NO	DATE	BY	CKD	APPR	REVISION
NAME: P:\002-618-032\Plan\0261832_XS1.dgn 04/22/2019 7:48:27 AM					

DRAWN BY KT DATE 10/24/18
 DESIGN BY JCF DATE 10/24/18
 CHECKED BY NJD DATE 10/24/18

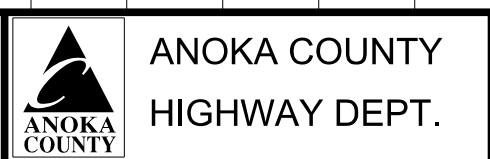

SP 002-618-032
 CROSS SECTIONS
 STA 85+70.00 TO 88+00.00
 Sheet 110 of 126 Sheets

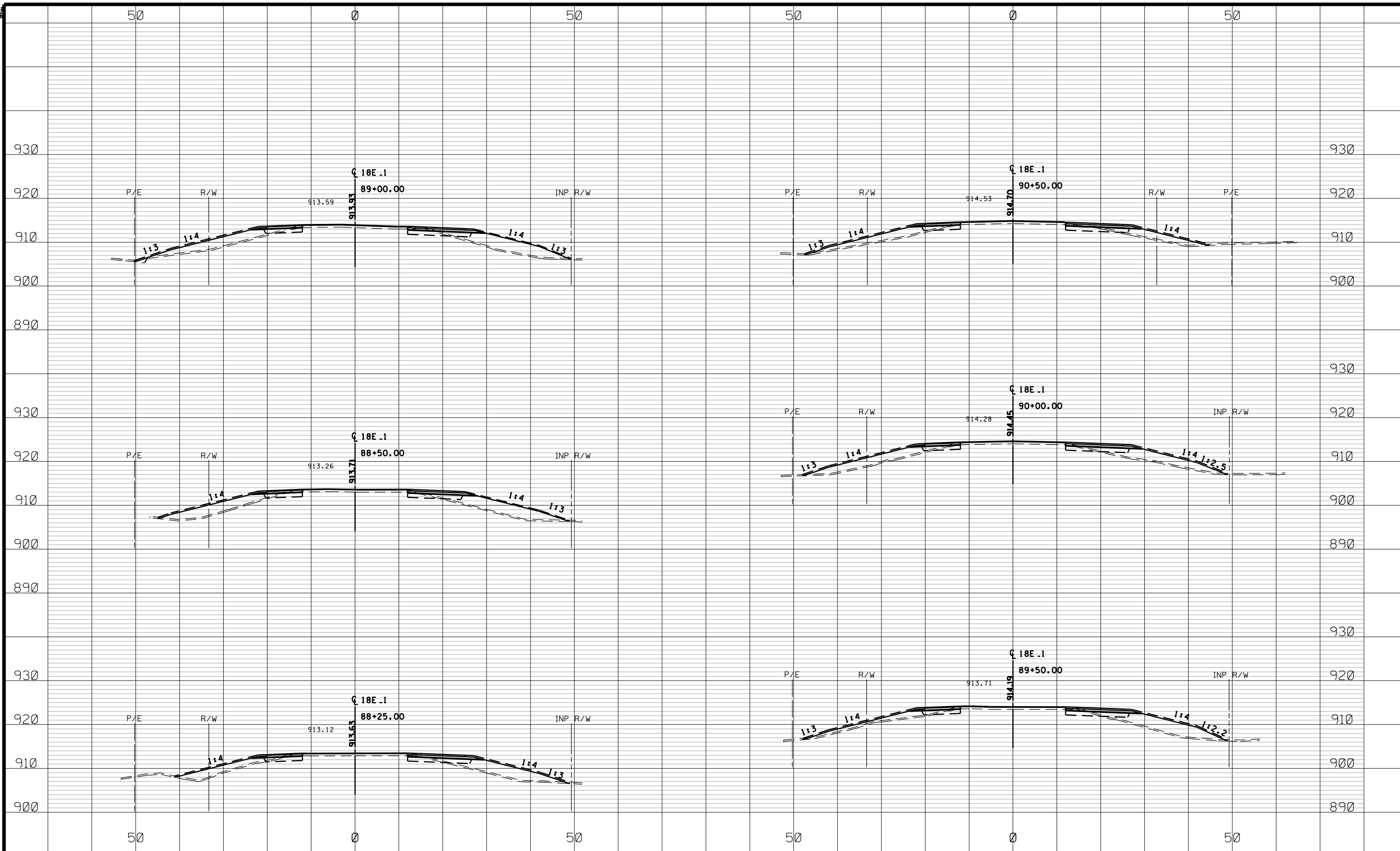

1	04/22/19	DF	JF	NJD	ADDED SUBCUT INFORMATION
NO	DATE	BY	CKD	APPR	REVISION
NAME: P:\002-618-032\Plan\0261832_XS1.dgn 04/22/2019 7:48:27 AM					

DRAWN BY KT DATE 10/24/18
 DESIGN BY JCF DATE 10/24/18
 CHECKED BY NJD DATE 10/24/18

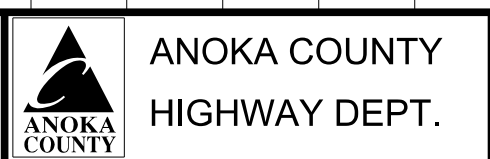

SP 002-618-032

CROSS SECTIONS
 STA 88+25.00 TO 90+50.00
 Sheet 111 of 126 Sheets

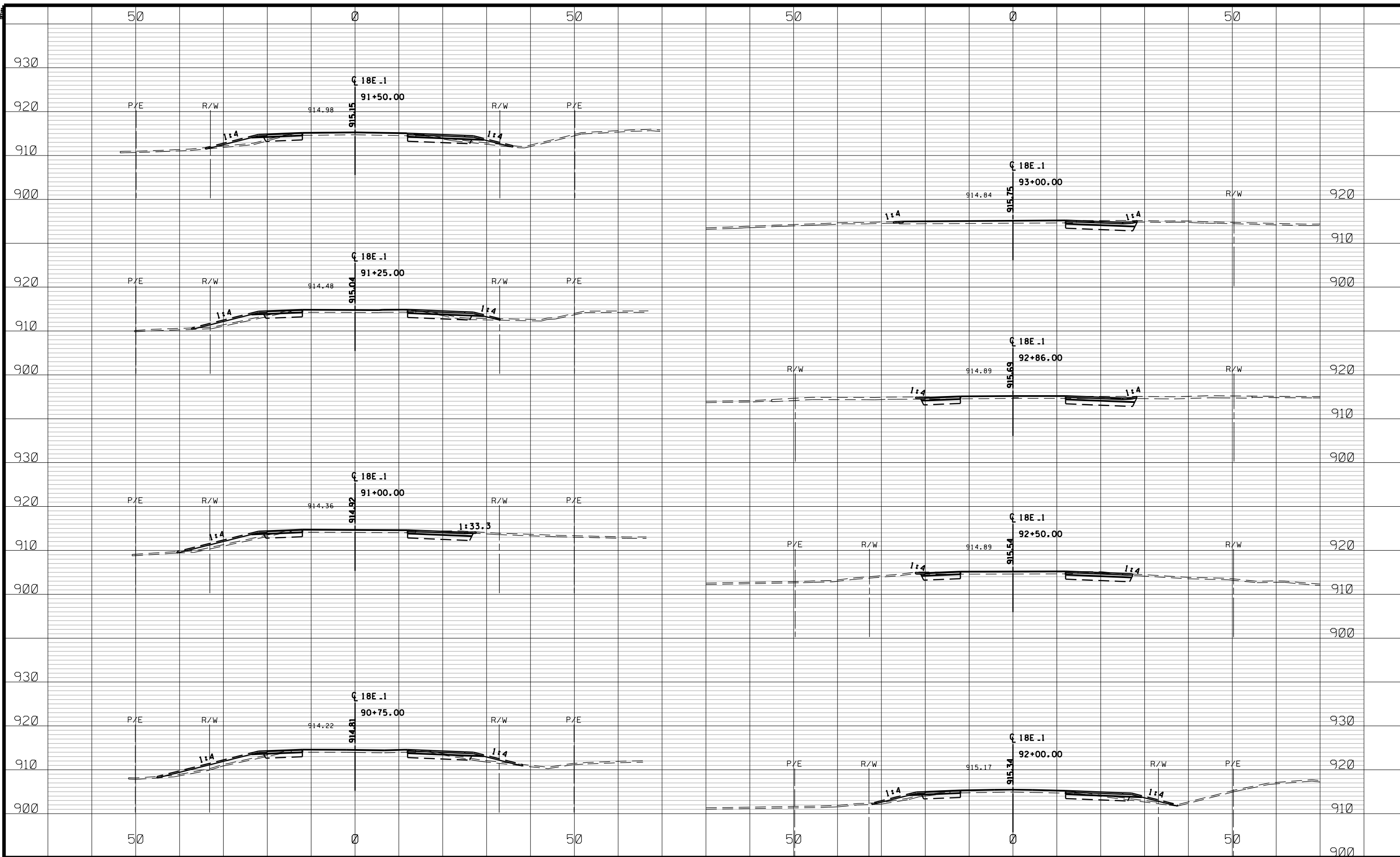

1	04/22/19	DF	JF	NJD	ADDED SUBCUT INFORMATION
NO	DATE	BY	CKD	APPR	REVISION
NAME: P:\002-618-032\Plan\0261832_XS1.dgn					04/22/2019 7:48:28 AM

DRAWN BY KT DATE 10/24/18
 DESIGN BY JCF DATE 10/24/18
 CHECKED BY NJD DATE 10/24/18

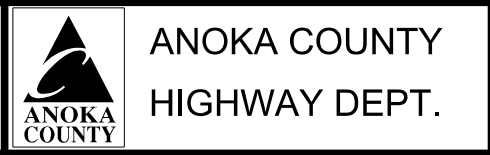

SP 002-618-032

CROSS SECTIONS
 STA 90+75.00 TO 93+00.00
 Sheet 112 of 126 Sheets

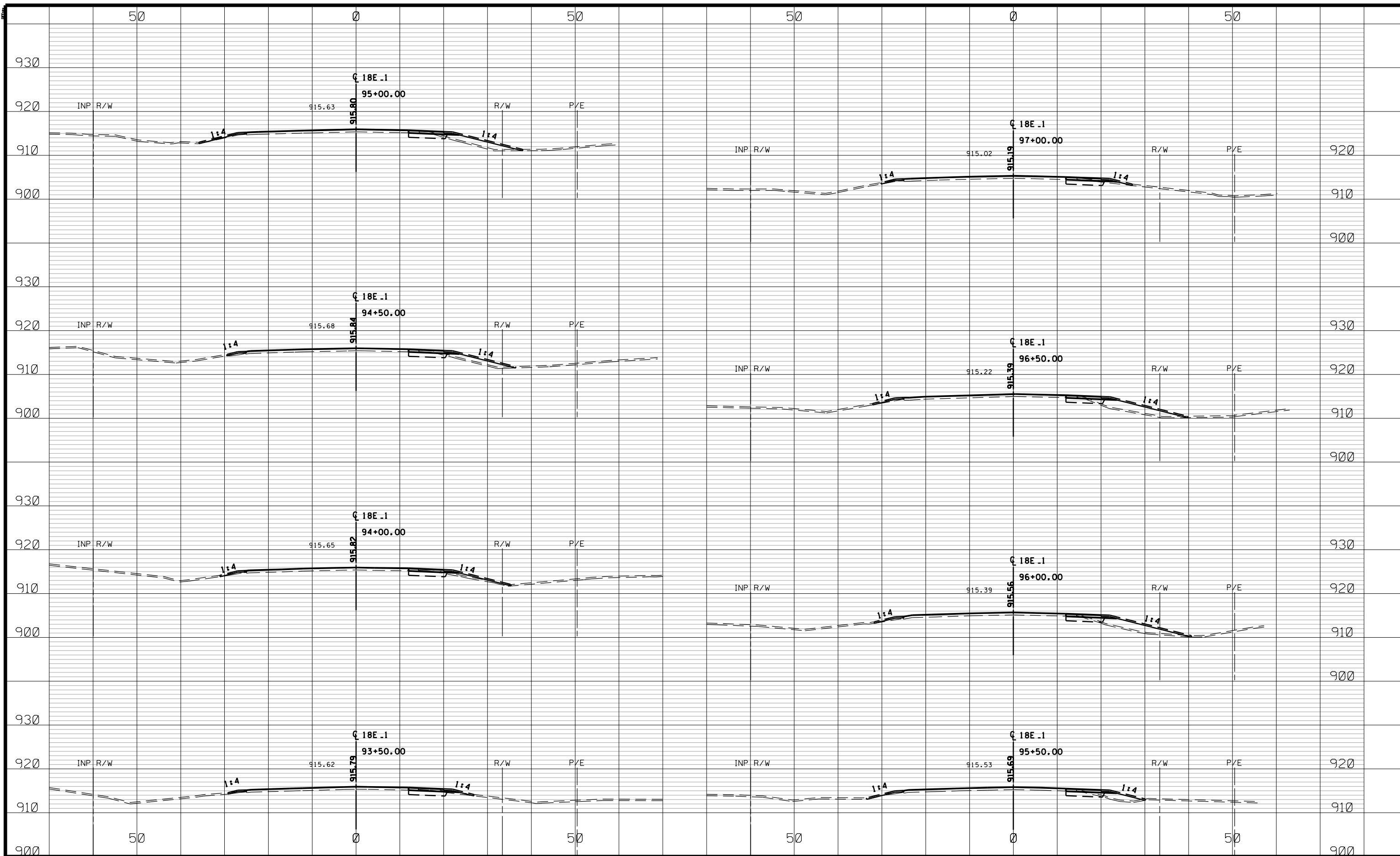

1	04/22/19	DF	JF	NJD	ADDED SUBCUT INFORMATION
NO	DATE	BY	CKD	APPR	REVISION
NAME: P:\002-618-032\Plan\0261832_XS1.dgn					04/22/2019 7:48:28 AM

DRAWN BY KT DATE 10/24/18
 DESIGN BY JCF DATE 10/24/18
 CHECKED BY NJD DATE 10/24/18

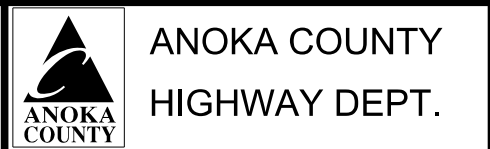

SP 002-618-032

CROSS SECTIONS
 STA 93+50.00 TO 97+00.00
 Sheet 113 of 126 Sheets

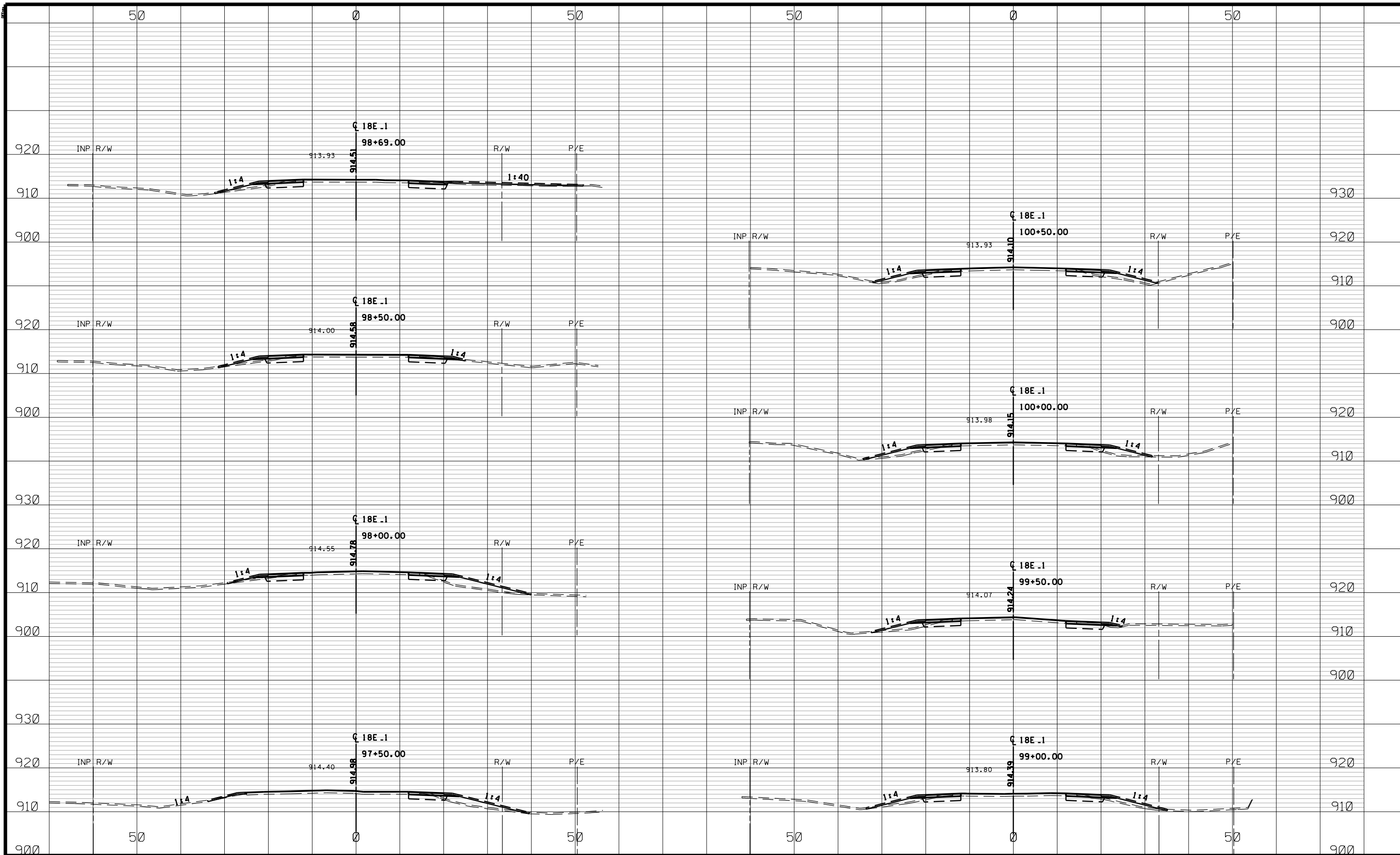

1	04/22/19	DF	JF	NJD	ADDED SUBCUT INFORMATION
NO	DATE	BY	CKD	APPR	REVISION
NAME: P:\002-618-032\Plan\0261832_XS1.dgn 04/22/2019 7:48:29 AM					

DRAWN BY KT DATE 10/24/18
 DESIGN BY JCF DATE 10/24/18
 CHECKED BY NJD DATE 10/24/18

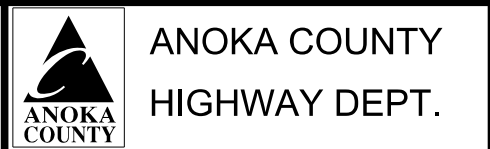

SP 002-618-032

CROSS SECTIONS
 STA 97+50.00 TO 100+50.00
 Sheet 114 of 126 Sheets

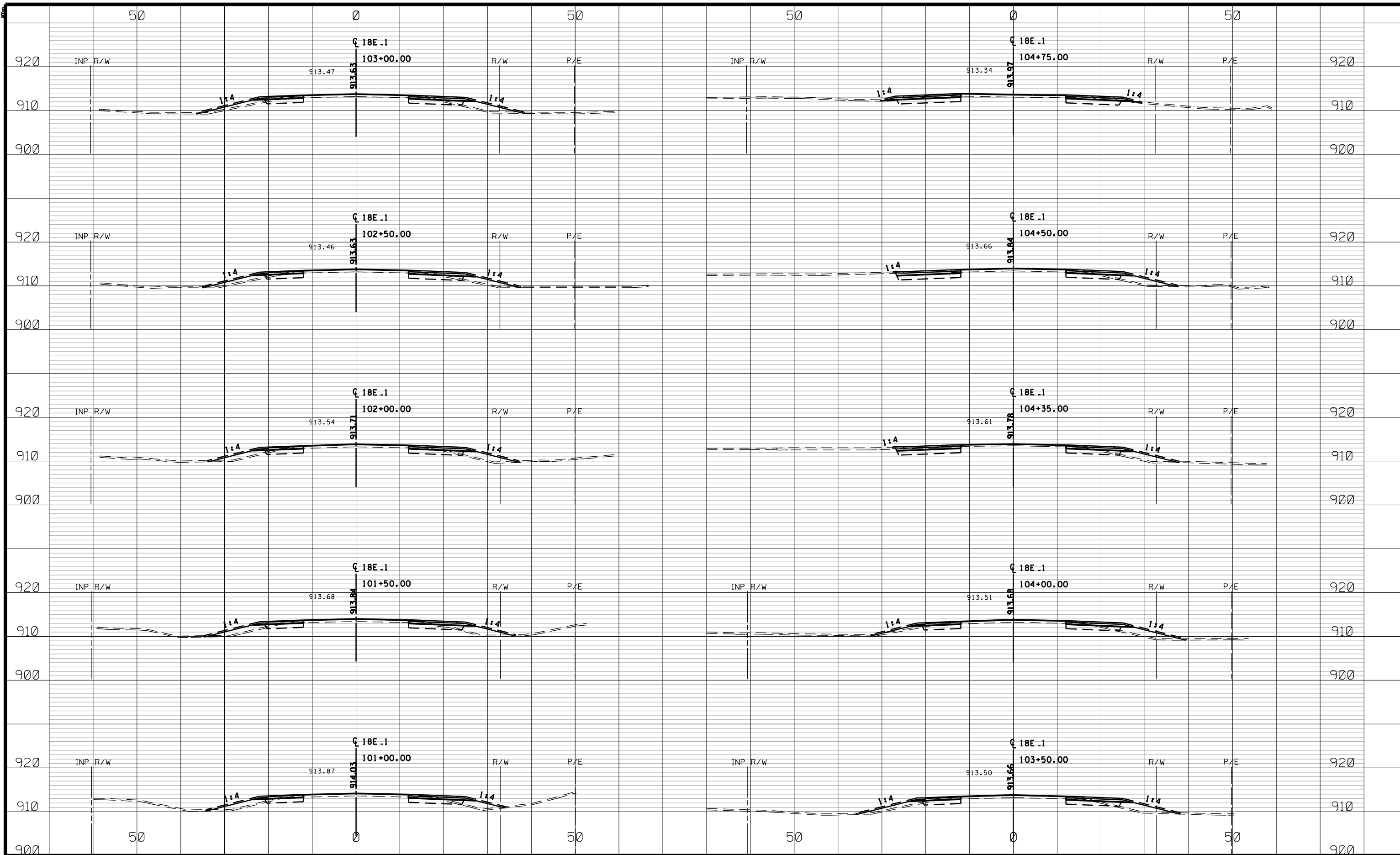

1	04/22/19	DF	JF	NJD	ADDED SUBCUT INFORMATION
NO	DATE	BY	CKD	APPR	REVISION
NAME: P:\002-618-032\Plan\0261832_XS1.dgn					04/22/2019 7:48:29 AM

DRAWN BY KT DATE 10/24/18
 DESIGN BY JCF DATE 10/24/18
 CHECKED BY NJD DATE 10/24/18

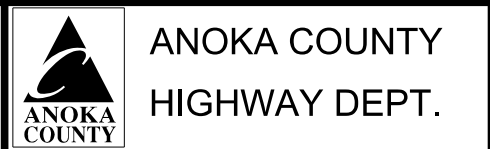

SP 002-618-032

CROSS SECTIONS
 STA 101+00.00 TO 104+75.00
 Sheet 115 of 126 Sheets

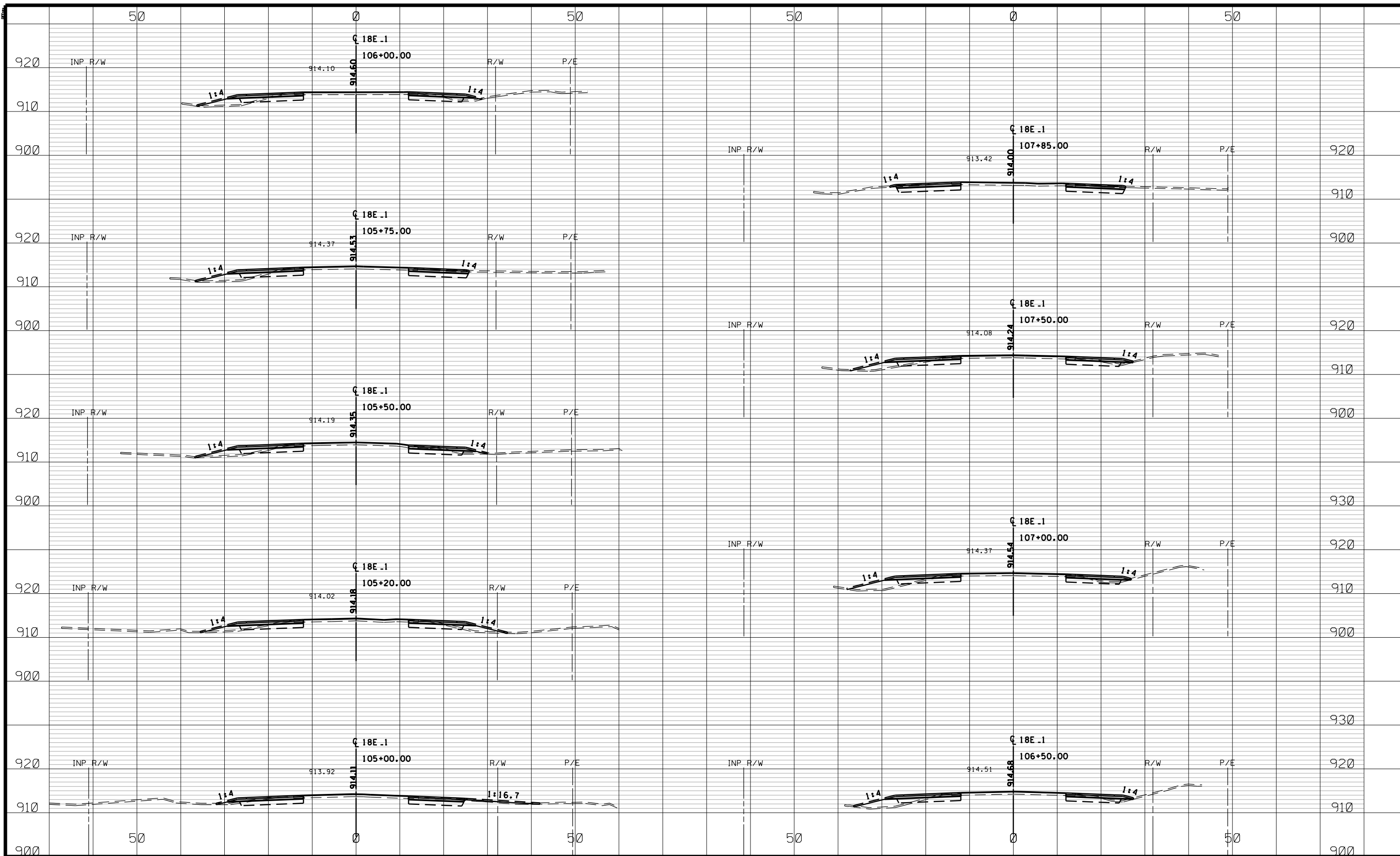

1	04/22/19	DF	JF	NJD	ADDED SUBCUT INFORMATION
NO	DATE	BY	CKD	APPR	REVISION
NAME: P:\002-618-032\Plan\0261832_XS1.dgn 04/22/2019 7:48:29 AM					

DRAWN BY KT DATE 10/24/18
 DESIGN BY JCF DATE 10/24/18
 CHECKED BY NJD DATE 10/24/18

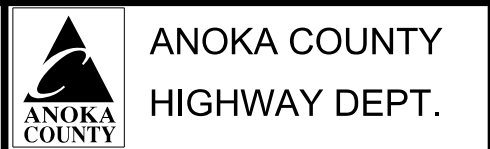

SP 002-618-032

CROSS SECTIONS
 STA 105+00.00 TO 107+85.00
 Sheet 116 of 126 Sheets

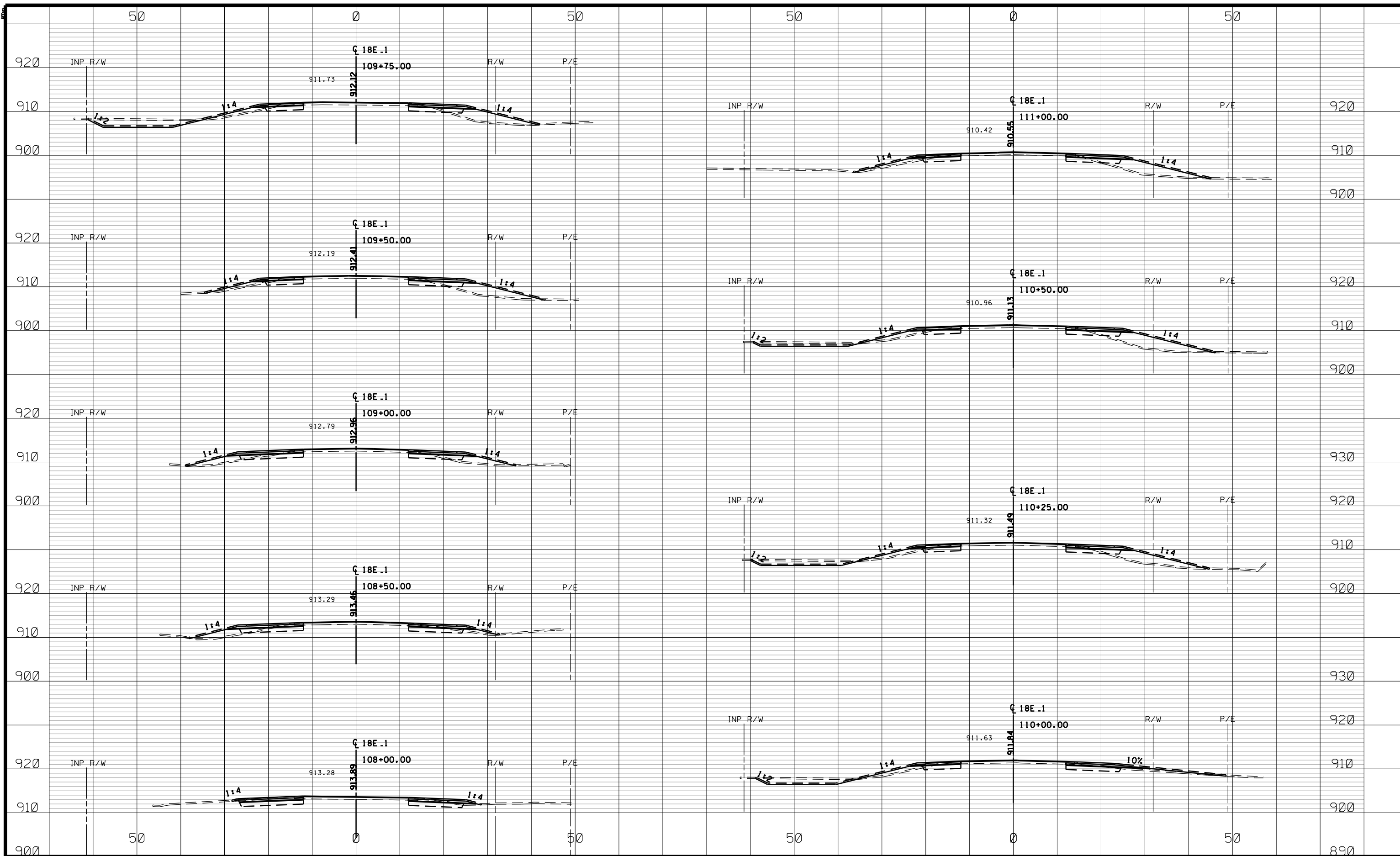

1	04/22/19	DF	JF	NJD	ADDED SUBCUT INFORMATION
NO	DATE	BY	CKD	APPR	REVISION
NAME: P:\002-618-032\Plan\0261832_XS1.dgn 04/22/2019 7:48:30 AM					

DRAWN BY KT DATE 10/24/18
 DESIGN BY JCF DATE 10/24/18
 CHECKED BY NJD DATE 10/24/18

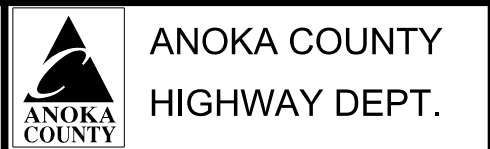

SP 002-618-032

CROSS SECTIONS
 STA 108+00.00 TO 111+00.00
 Sheet 117 of 126 Sheets

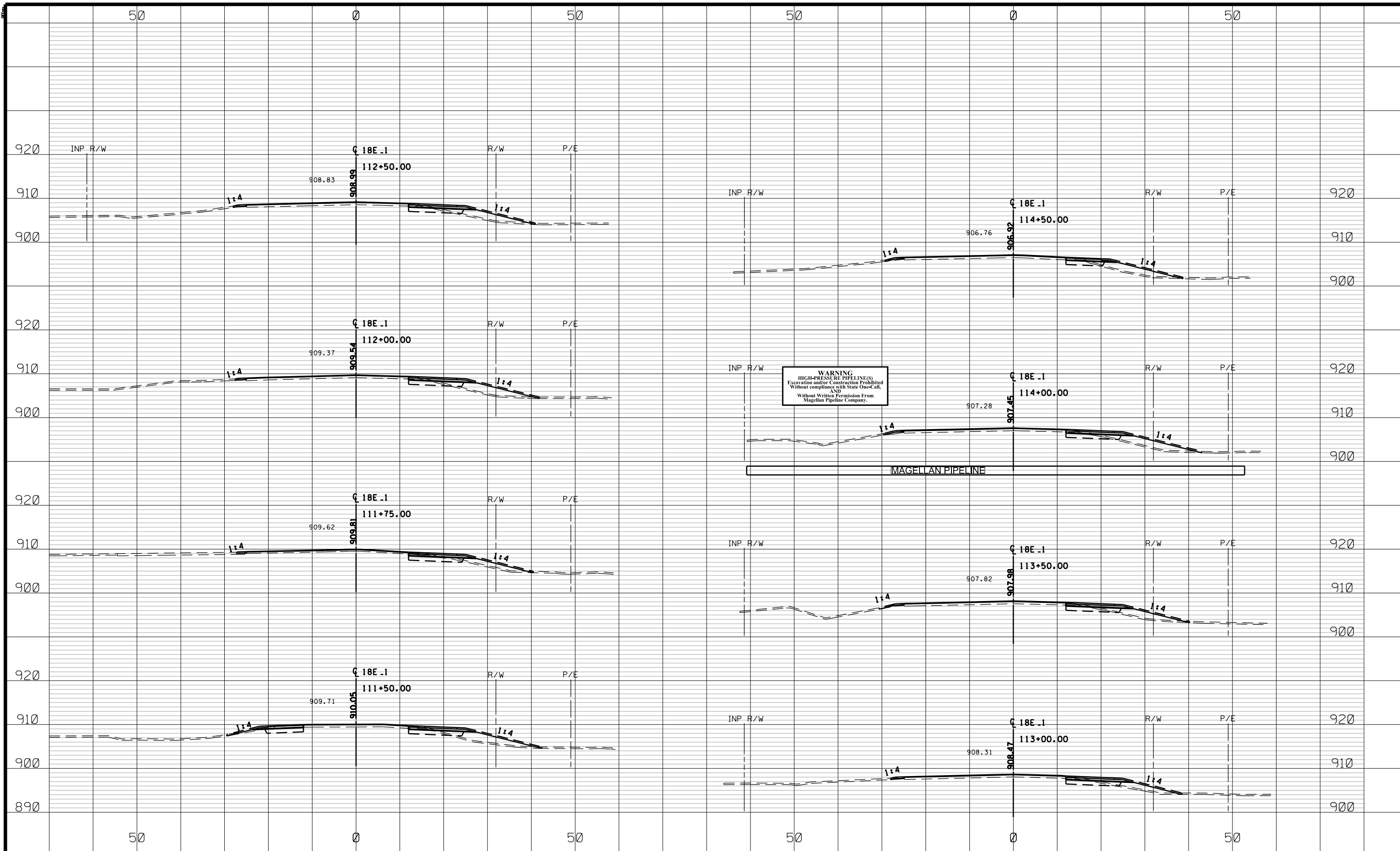

WARNING
 HIGH-PRESSURE PIPELINE(S)
 Excavation and/or Construction Prohibited
 Without compliance with State One-Call,
 AND
 Without Written Permission From
 Magellan Pipeline Company.

MAGELLAN PIPELINE

1	04/22/19	DF	JF	NJD	ADDED SUBCUT INFORMATION
NO	DATE	BY	CKD	APPR	REVISION
NAME: P:\002-618-032\Plan\0261832_XS1.dgn 04/22/2019 7:48:30 AM					

DRAWN BY KT DATE 10/24/18
 DESIGN BY JCF DATE 10/24/18
 CHECKED BY NJD DATE 10/24/18

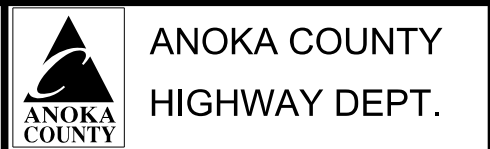

SP 002-618-032

CROSS SECTIONS
 STA 111+50.00 TO 114+50.00
 Sheet 118 of 126 Sheets

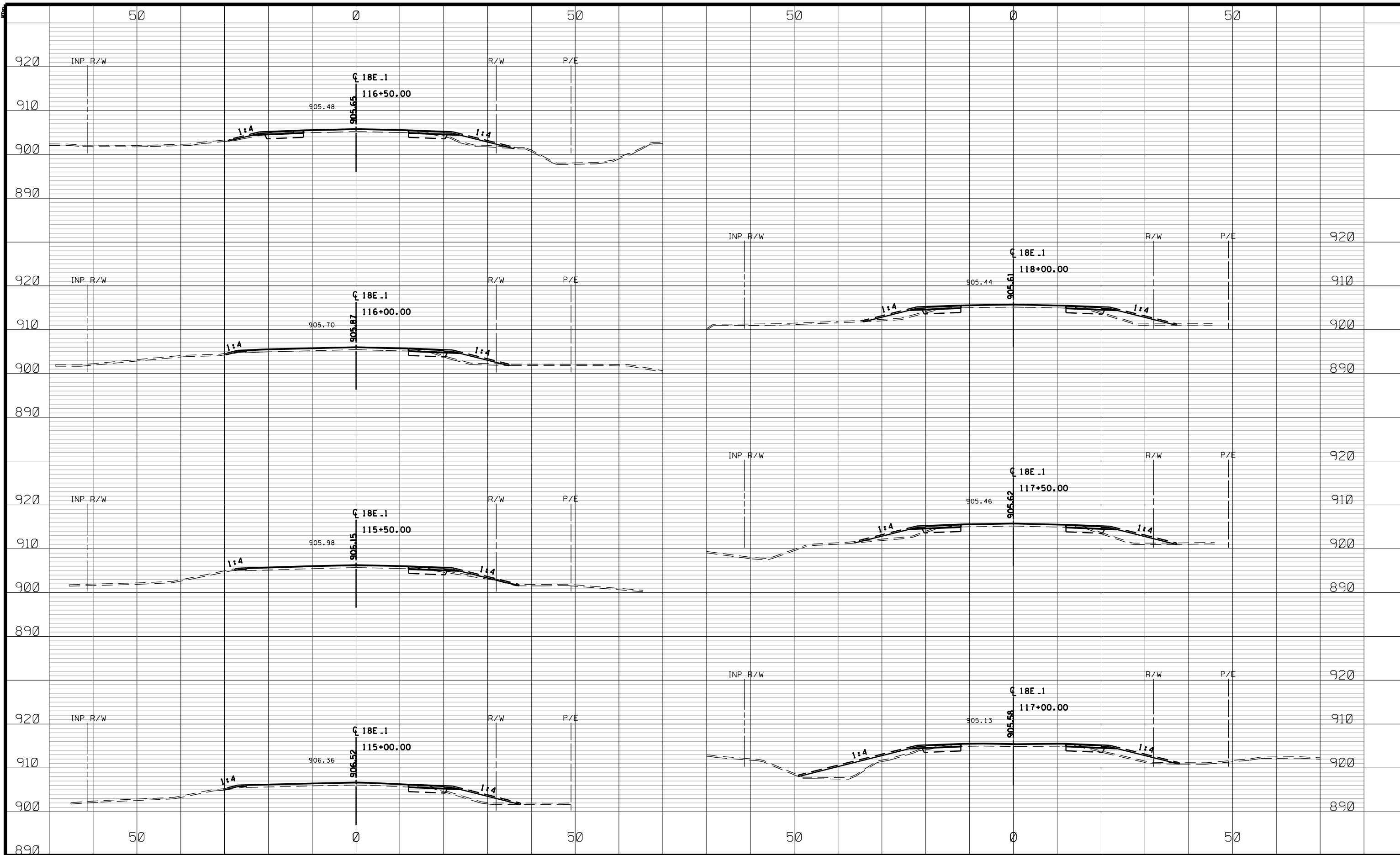

1	04/22/19	DF	JF	NJD	ADDED SUBCUT INFORMATION
NO	DATE	BY	CKD	APPR	REVISION
NAME: P:\002-618-032\Plan\0261832_XS1.dgn					
04/22/2019 7:48:31 AM					

DRAWN BY KT DATE 10/24/18
 DESIGN BY JCF DATE 10/24/18
 CHECKED BY NJD DATE 10/24/18

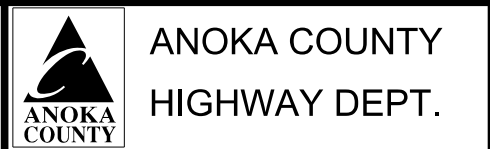

SP 002-618-032

CROSS SECTIONS
 STA 115+00.00 TO 118+00.00
 Sheet 119 of 126 Sheets

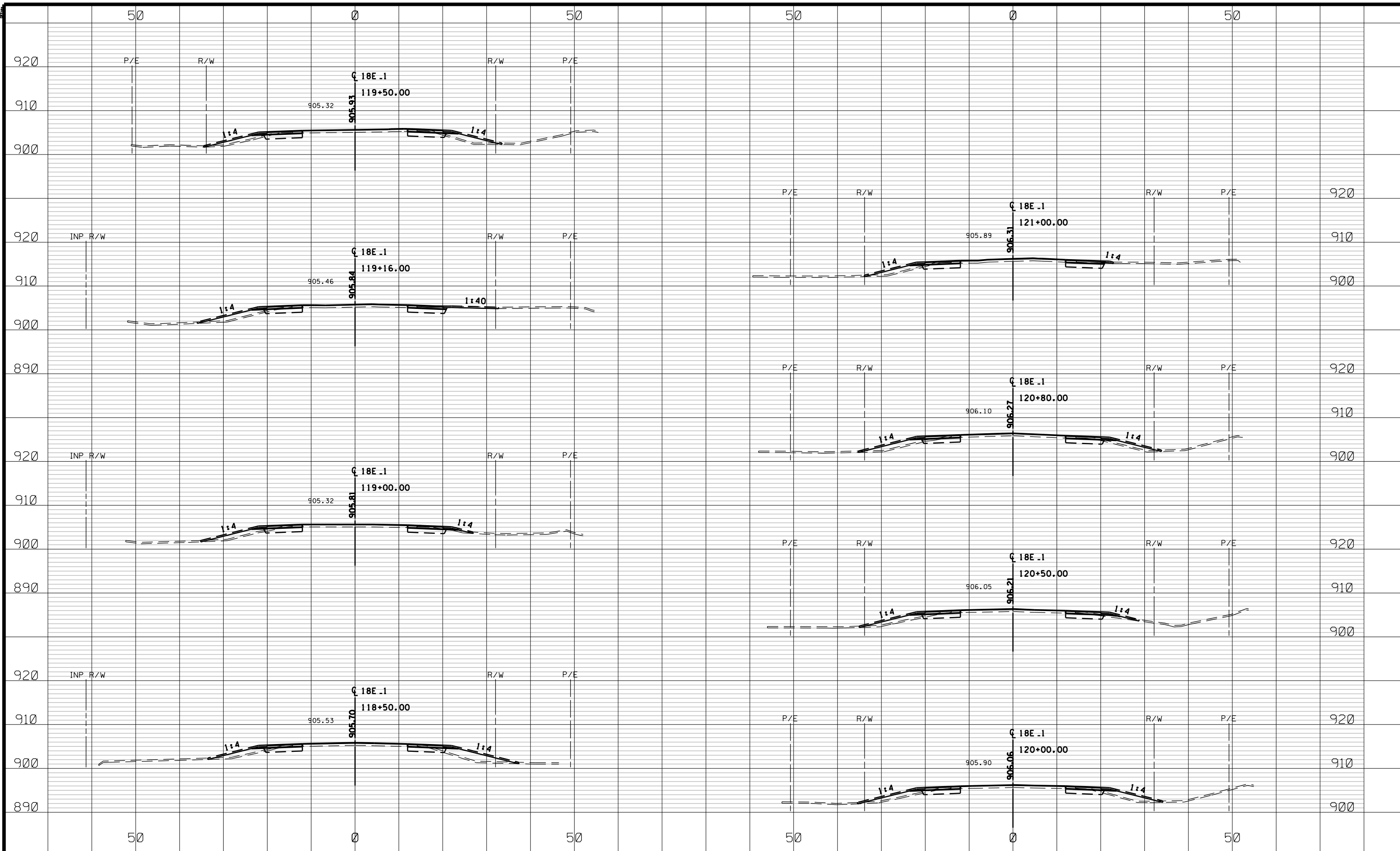

1	04/22/19	DF	JF	NJD	ADDED SUBCUT INFORMATION
NO	DATE	BY	CKD	APPR	REVISION
NAME: P:\002-618-032\Plan\0261832_XS1.dgn					
04/22/2019 7:48:31 AM					

DRAWN BY KT DATE 10/24/18
 DESIGN BY JCF DATE 10/24/18
 CHECKED BY NJD DATE 10/24/18

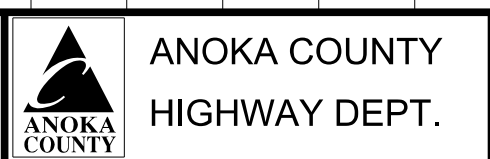

SP 002-618-032
 CROSS SECTIONS
 STA 118+50.00 TO 121+00.00
 Sheet 120 of 126 Sheets

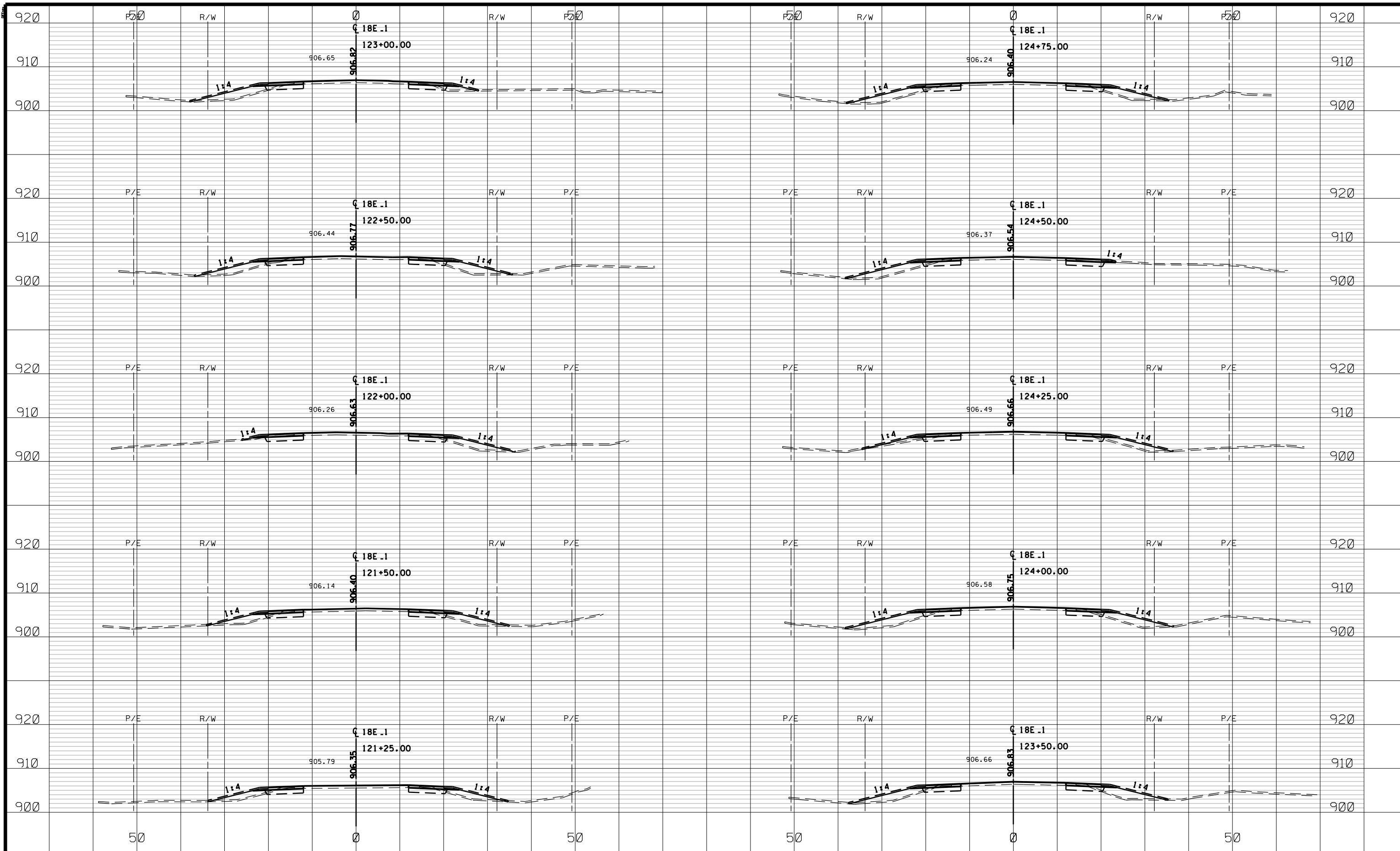

1	04/22/19	DF	JF	NJD	ADDED SUBCUT INFORMATION
NO	DATE	BY	CKD	APPR	REVISION
NAME: P:\002-618-032\Plan\0261832_XS1.dgn					
04/22/2019 7:48:31 AM					

50	0	50
----	---	----

DRAWN BY KT DATE 10/24/18
 DESIGN BY JCF DATE 10/24/18
 CHECKED BY NJD DATE 10/24/18

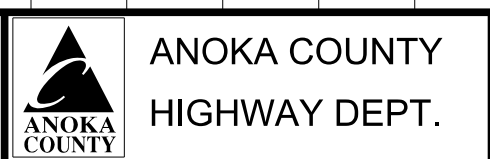

SP 002-618-032

CROSS SECTIONS
 STA 121+25.00 TO 124+75.00
 Sheet 121 of 126 Sheets

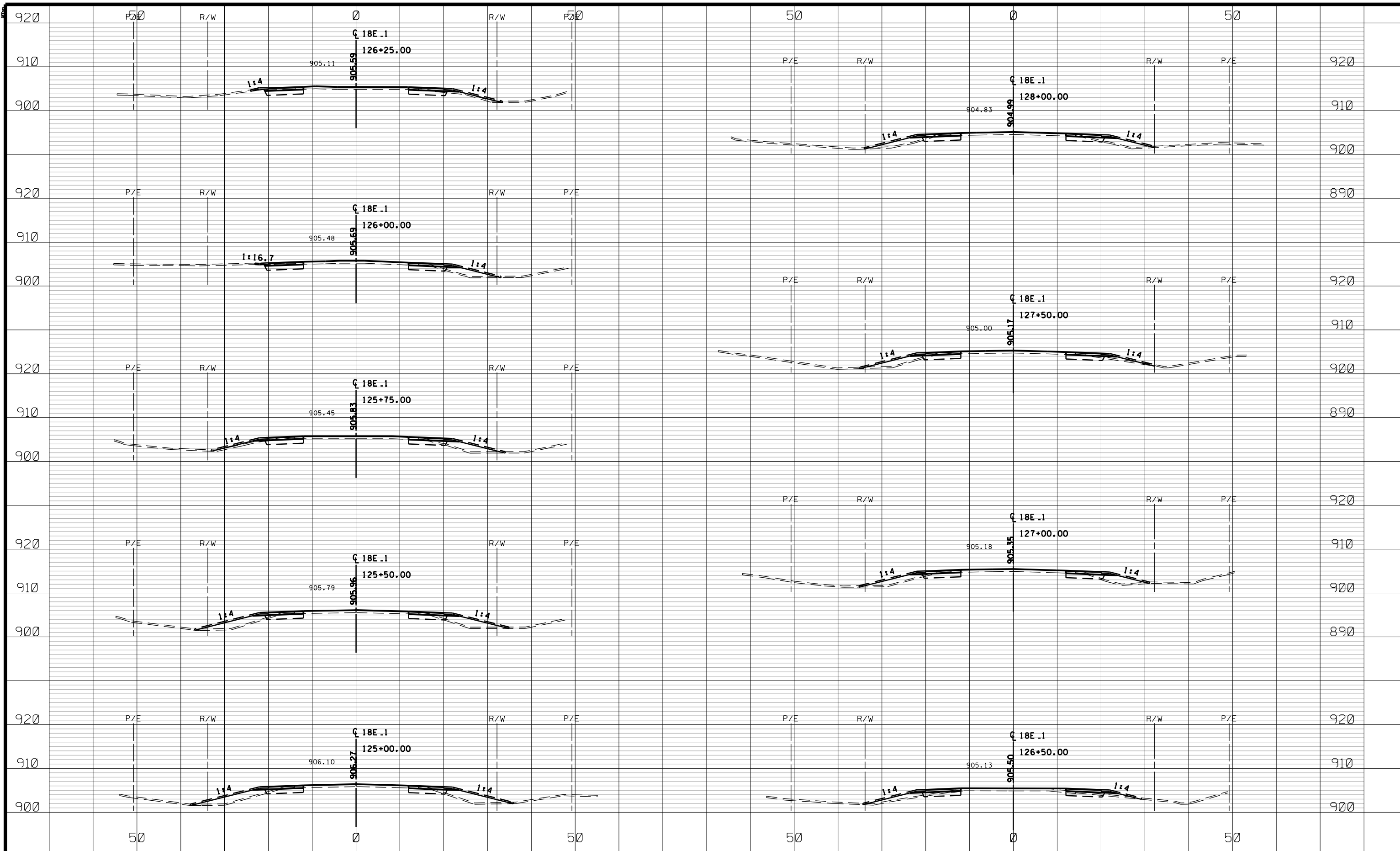

1	04/22/19	DF	JF	NJD	ADDED SUBCUT INFORMATION
NO	DATE	BY	CKD	APPR	REVISION
NAME: P:\002-618-032\Plan\0261832_XS1.dgn 04/22/2019 7:48:32 AM					

DRAWN BY KT DATE 10/24/18
DESIGN BY JCF DATE 10/24/18
CHECKED BY NJD DATE 10/24/18

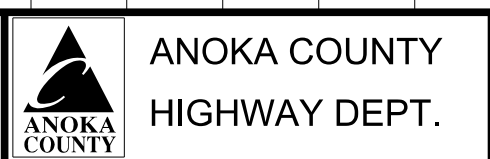

SP 002-618-032

CROSS SECTIONS
STA 125+00.00 TO 128+00.00
Sheet 122 of 126 Sheets

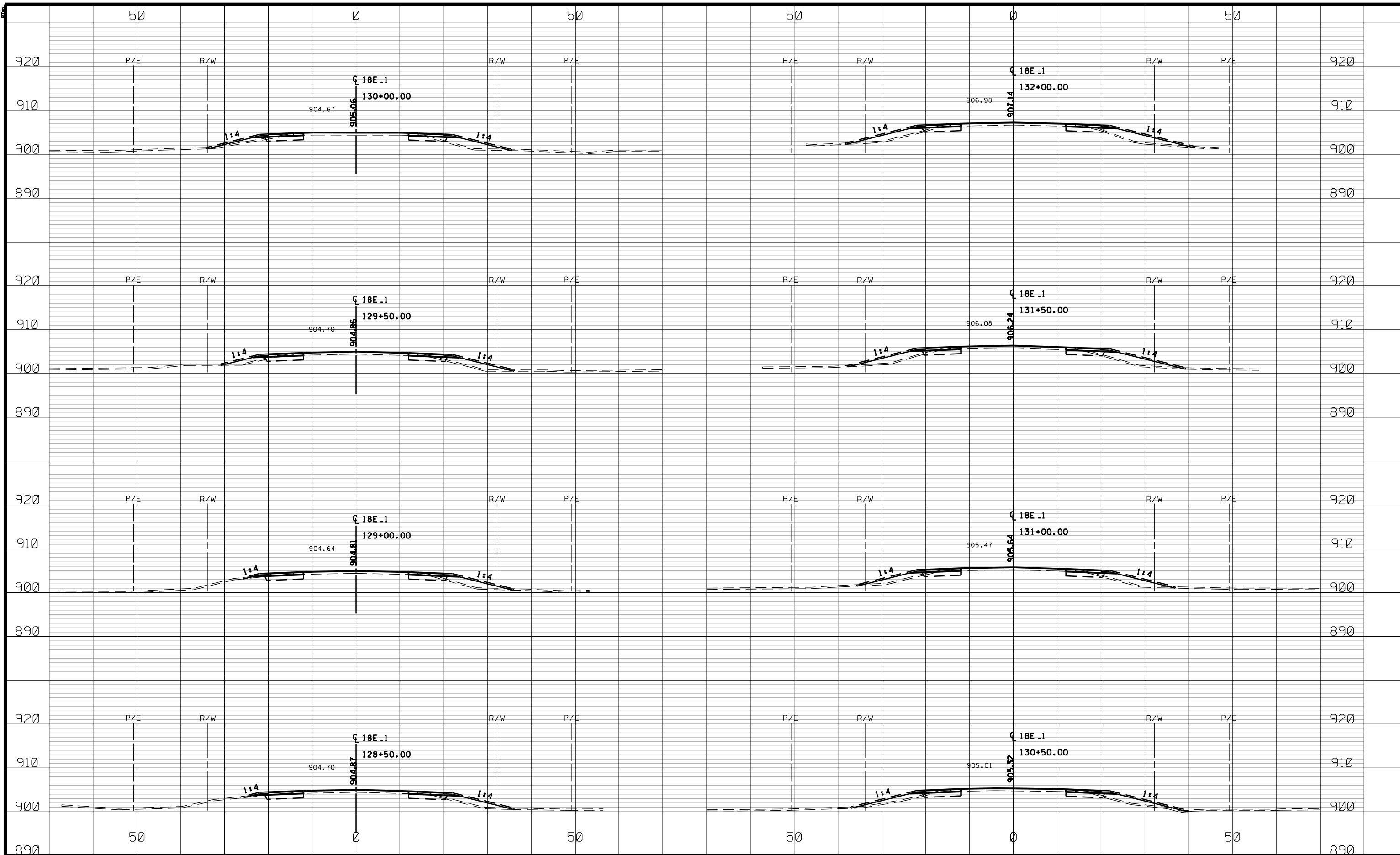

1	04/22/19	DF	JF	NJD	ADDED SUBCUT INFORMATION
NO	DATE	BY	CKD	APPR	REVISION
NAME: P:\002-618-032\Plan\0261832_XS1.dgn 04/22/2019 7:48:32 AM					

DRAWN BY KT DATE 10/24/18
 DESIGN BY JCF DATE 10/24/18
 CHECKED BY NJD DATE 10/24/18

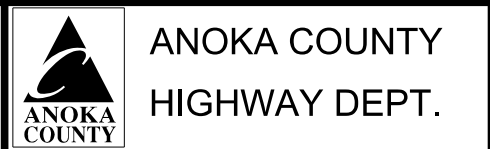

SP 002-618-032

CROSS SECTIONS
 STA 128+50.00 TO 132+00.00
 Sheet 123 of 126 Sheets

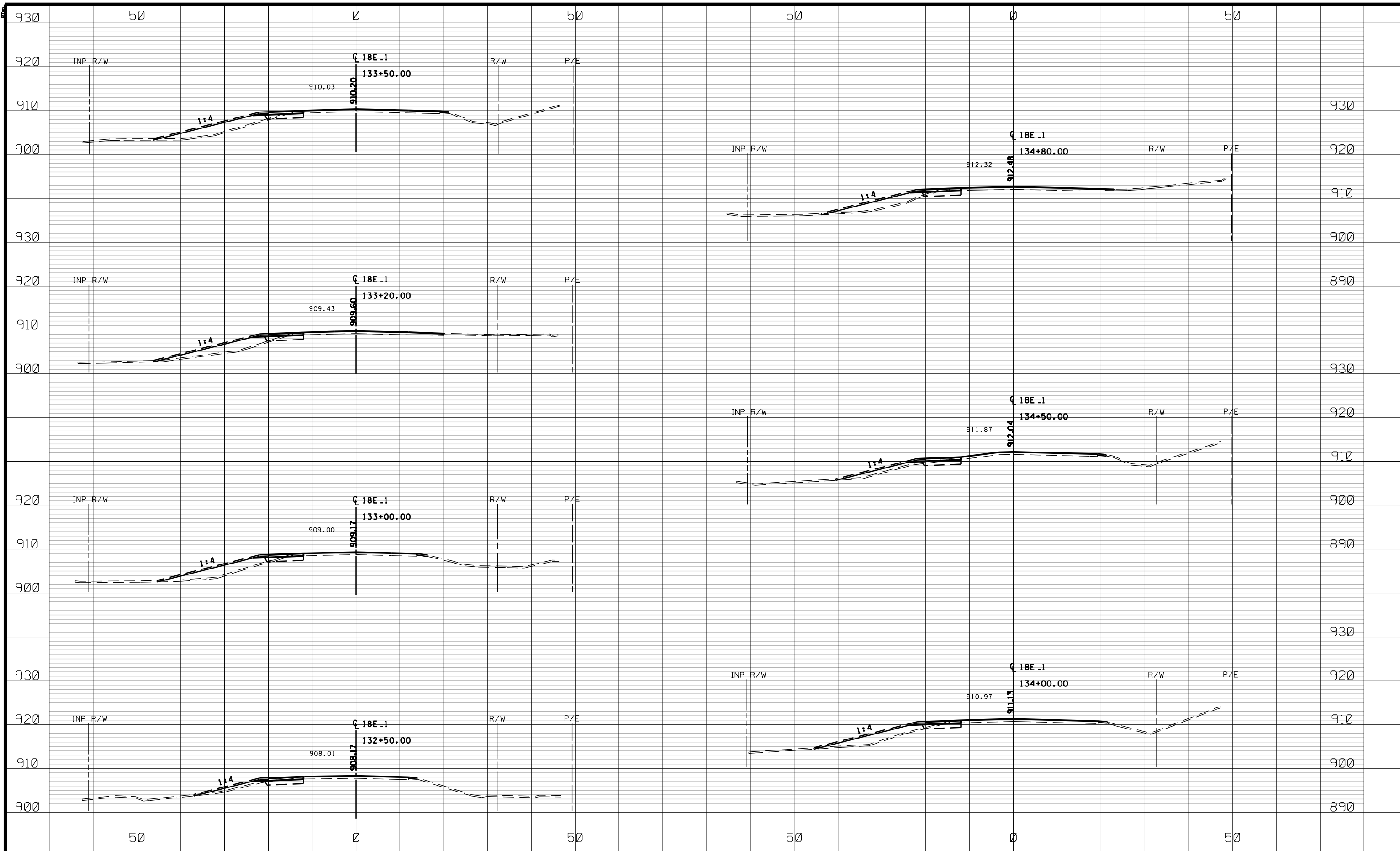

1	04/22/19	DF	JF	NJD	ADDED SUBCUT INFORMATION
NO	DATE	BY	CKD	APPR	REVISION
NAME: P:\002-618-032\Plan\0261832_XS1.dgn					
04/22/2019 7:48:33 AM					

DRAWN BY KT DATE 10/24/18
 DESIGN BY JCF DATE 10/24/18
 CHECKED BY NJD DATE 10/24/18

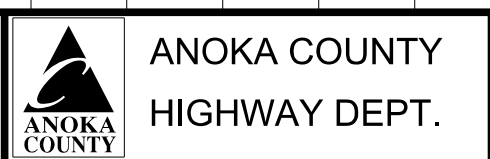

SP 002-618-032

CROSS SECTIONS
 STA 132+50.00 TO 134+80.00
 Sheet 124 of 126 Sheets

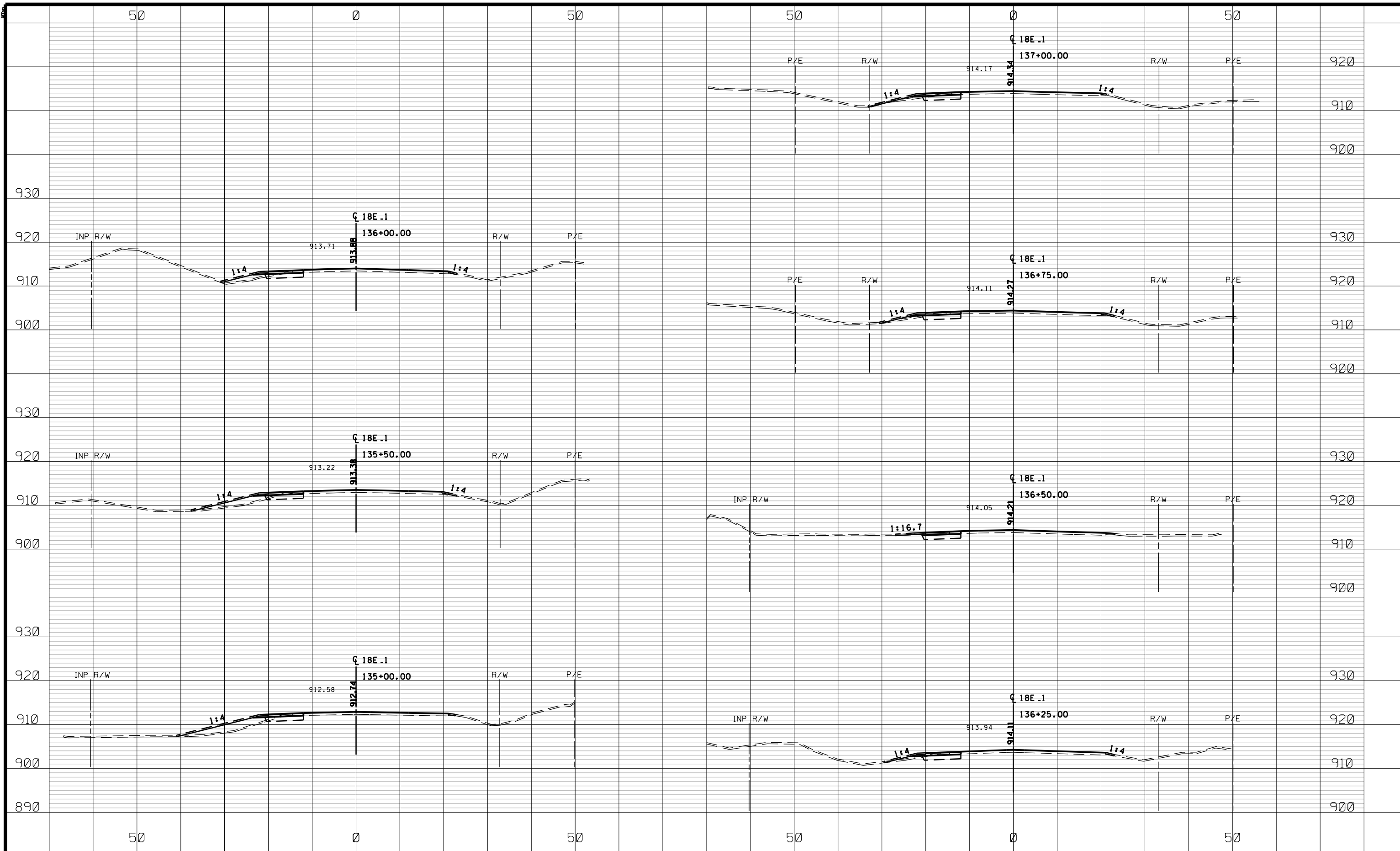

1	04/22/19	DF	JF	NJD	ADDED SUBCUT INFORMATION
NO	DATE	BY	CKD	APPR	REVISION
NAME: P:\002-618-032\Plan\0261832_XS1.dgn 04/22/2019 7:48:33 AM					

DRAWN BY KT DATE 10/24/18
 DESIGN BY JCF DATE 10/24/18
 CHECKED BY NJD DATE 10/24/18

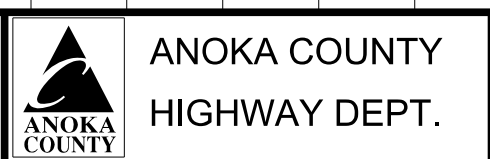

SP 002-618-032

CROSS SECTIONS
 STA 135+00.00 TO 137+00.00
 Sheet 125 of 126 Sheets

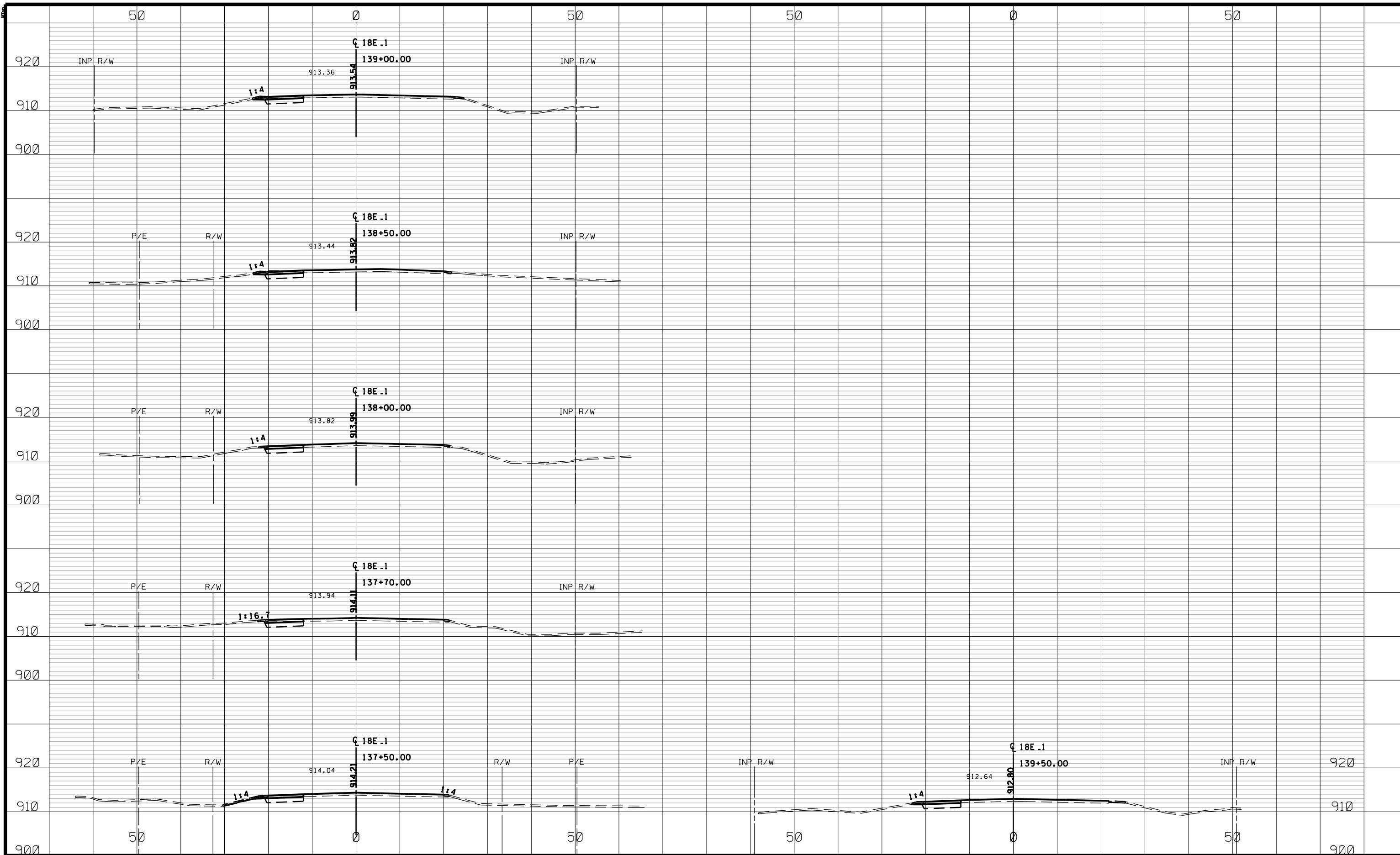

1	04/22/19	DF	JF	NJD	ADDED SUBCUT INFORMATION
NO	DATE	BY	CKD	APPR	REVISION
NAME: P:\002-618-032\Plan\0261832_XS1.dgn 04/22/2019 7:48:33 AM					

DRAWN BY KT DATE 10/24/18
 DESIGN BY JCF DATE 10/24/18
 CHECKED BY NJD DATE 10/24/18

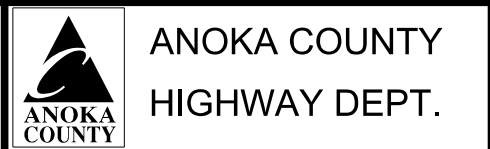

SP 002-618-032

CROSS SECTIONS
 STA 137+50.00 TO 139+50.00
 Sheet 126 of 126 Sheets