

PLAN SYMBOLS

- COUNTY LINE _____
- TOWNSHIP OR RANGE LINE _____
- SECTION LINE _____
- QUARTER LINE _____
- SIXTEENTH LINE _____
- RIGHT OF WAY LINE _____
- SLOPE EASEMENT _____
- EXISTING RIGHT OF WAY _____
- PROPERTY LINE _____
- CORPORATE OR CITY LIMITS _____
- RETAINING WALL _____
- RAILROAD _____
- RAILROAD RIGHT OF WAY _____
- RIVER OR CREEK _____
- DRAINAGE DITCH _____
- CULVERT _____
- DROP INLET _____
- GUARD RAIL _____
- BARBED WIRE FENCE _____
- WOVEN WIRE FENCE _____
- CHAIN LINK FENCE _____
- WOOD FENCE _____
- STONE WALL OR FENCE _____
- HEDGE _____

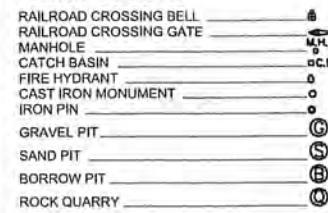

UTILITY SYMBOLS

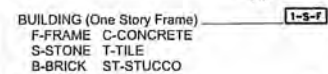
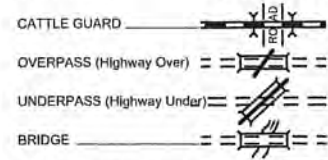
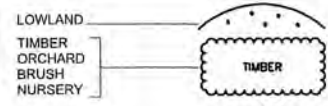
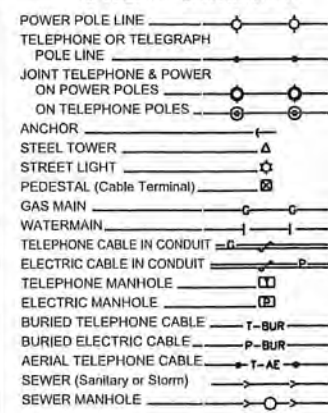

SCALES

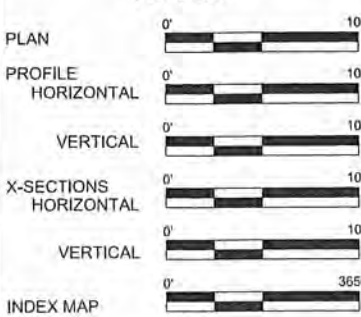

MINNESOTA DEPARTMENT OF TRANSPORTATION ANOKA COUNTY

CONSTRUCTION PLAN FOR _____ GRADING, BIT. RECLAMATION, BIT. SURFACING, STORM SEWER, AND SIGNING.

LOCATED ON C.S.A.H. 21 BETWEEN CSAH 34 (BIRCH STREET) AND 103' SOUTH OF EB CSAH 14 (MAIN STREET)

COUNTY PROJ. NO. 002-621-010

C.S.A.H. 21

GROSS LENGTH	6,583.30	FEET	1.247	MILES
BRIDGES-LENGTH	0.00	FEET	0.000	MILES
EXCEPTIONS-LENGTH	0.00	FEET	0.000	MILES
NET LENGTH	6,583.30	FEET	1.247	MILES

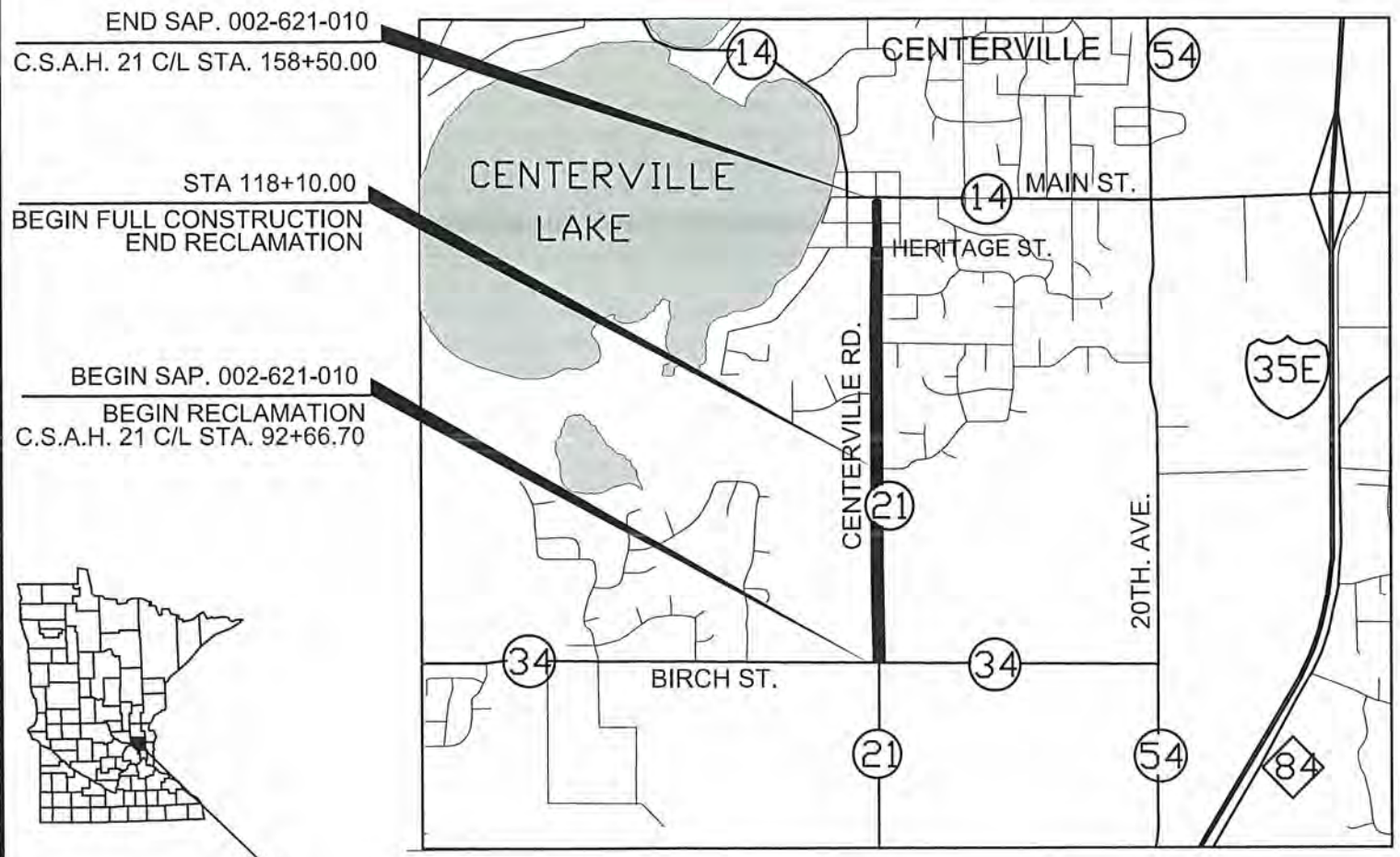

PROJECT LOCATION
CITIES OF LINO LAKES
AND CENTERVILLE
ANOKA COUNTY
MN/DOT TRANSPORTATION DISTRICT - METRO
SECTIONS 23 & 26
TOWNSHIP 31 NORTH
RANGE 22 WEST

DESIGN DESIGNATION - BIKE PATH
DESIGN SPEED (MPH) 20
BASED ON:
4.5 FT HEIGHT OF EYE
0.0 FT HEIGHT OF OBJECT

DESIGN DESIGNATION		FUNCTIONAL CLASSIFICATION <u>A MINOR ARTERIAL, EXPANDER</u>	
ESAL ₂₀	664,318	NO. OF TRAFFIC LANES	<u>2</u>
R VALUE	15	NO. OF PARKING LANES	<u>0</u>
ADT (2014)	4,326	DESIGN SPEED	<u>45 & 30</u> MPH
PROJ. ADT (2034)	6,921	STOPPING SIGHT DISTANCE BASED ON:	
PROJ. HCADT (2034)	408	HEIGHT OF EYE	<u>3.5'</u>
SOIL FACTOR	NA	HEIGHT OF OBJECT	<u>2.0'</u>
	10 TON DESIGN	DESIGN SPEED NOT ACHIEVED AT:	
		STA. _____ TO STA. _____	MPH _____

MINN. PROJ. NO. _____

GOVERNING SPECIFICATIONS

THE 2005 EDITION OF THE MINNESOTA DEPARTMENT OF TRANSPORTATION "STANDARD SPECIFICATIONS FOR CONSTRUCTION" SHALL GOVERN.

ALL TRAFFIC CONTROL DEVICES SHALL CONFORM AND BE INSTALLED IN ACCORDANCE TO THE "MINNESOTA MANUAL ON UNIFORM TRAFFIC CONTROL DEVICES" (MNMUTCD), AND PART VI, "FIELD MANUAL FOR TEMPORARY TRAFFIC CONTROL ZONE LAYOUTS."

INDEX

SHEET NO.	DESCRIPTION
1	TITLE SHEET
2	GENERAL LAYOUT
3 - 5	STATEMENT OF ESTIMATED QUANTITIES,
6	STANDARD PLATES, BASIS OF QUANTITIES, & INDEX OF TABULATIONS
7 - 15	TABULATION CHARTS
16 - 17	EARTHWORK AND CONSTRUCTION NOTES
18 - 20	TYPICAL SECTIONS / MISCELLANEOUS DETAILS
21 - 25	PEDESTRIAN CURB RAMP DETAILS
26 - 31	CONSTRUCTION STAGING & TRAFFIC CONTROL
32 - 33	ALIGNMENT TABULATION AND PLAN
34 - 36	INPLACE TOPOGRAPHY AND REMOVAL PLAN
37 - 39	EXISTING UTILITY PLAN
40 - 45	CONSTRUCTION PLAN & PROFILES
46 - 51	INTERSECTION DETAILS
52 - 61	DRAINAGE PLAN & TABULATIONS
62 - 63	SWPPP NARRATIVE
64 - 70	EROSION CONTROL PLAN & DETAILS
71 - 82	CENTERVILLE WATER, SEWER, & DRAINAGE DITCH
83 - 92	DETOUR & EXISTING SIGNING AND STRIPING PLAN
93 - 102	PERMANENT SIGNING / STRIPING PLAN
103 - 147	CROSS SECTIONS

THIS PLAN CONTAINS 147 SHEETS

Approved: _____ DATE 7/14/14
CITY OF CENTERVILLE ENGINEER

Approved: _____ DATE _____
CITY OF LINO LAKES ENGINEER

Approved: _____ DATE 7/14/14
ANOKA COUNTY ENGINEER

Approved: _____ DATE _____
DISTRICT STATE AID ENGINEER: REVIEWED FOR COMPLIANCE WITH STATE AID RULES/POLICY

Approved: _____ DATE _____
STATE AID ENGINEER: APPROVED FOR STATE AID FUNDING

NO	DATE	BY	CKD	APPR	REVISION

NAME: P:\02-621-10\Plan1_Title.dgn 07/14/2014 8:57:41 AM

I HEREBY CERTIFY THAT THIS PLAN WAS PREPARED BY ME OR UNDER MY DIRECT SUPERVISION AND THAT I AM A DULY LICENSED PROFESSIONAL ENGINEER UNDER THE LAWS OF THE STATE OF MINNESOTA.
PRINT NAME: CURT A. KOBIARCSIK
SIGNATURE: _____
DATE: 7-14-14 LICENSE NO. 24756

DRAWN BY ZB DATE 07-07-14
DESIGN BY MN DATE 07-07-14
CHECKED BY CAK DATE 07-11-14

**ANOKA COUNTY
HIGHWAY DEPT.**

S.A.P. 002-621-010

TITLE SHEET
Sheet 1 of 147 Sheets

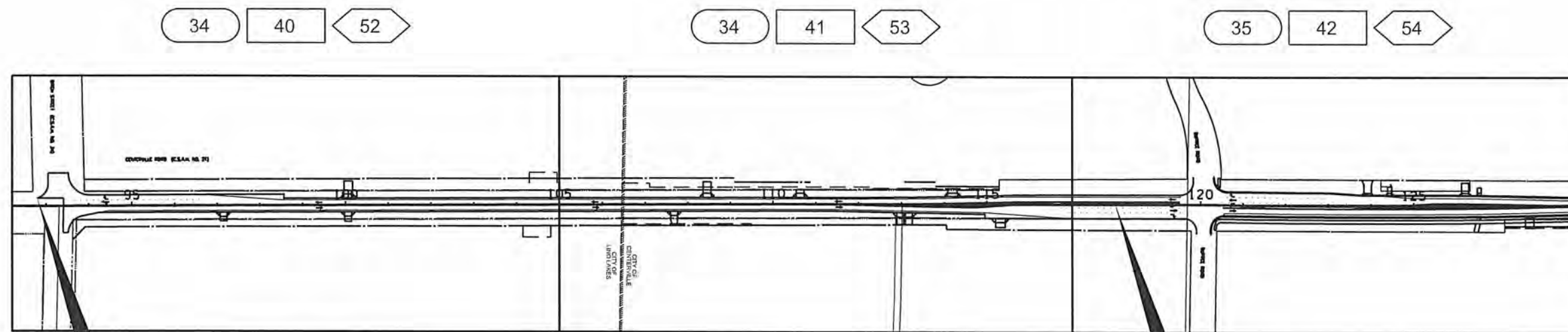

BEGIN S.P. 002-621-010
C.S.A.H. 21 STA. 92+66.70
BEGIN RECLAMATION

STA 118+10.00
END RECLAMATION
BEGIN FULL CONSTRUCTION

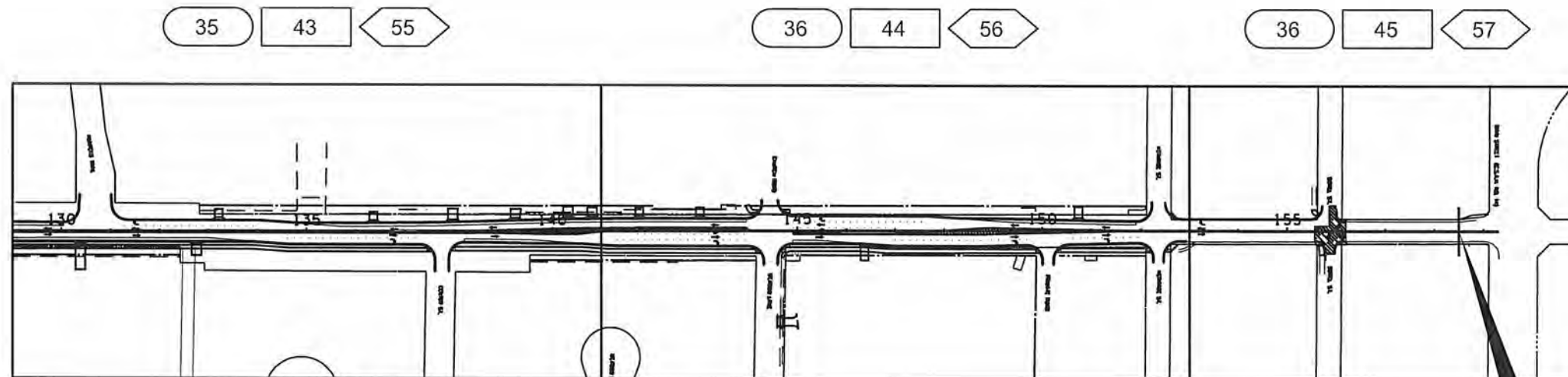

END S.P. 002-621-010
C.S.A.H. 21 STA. 158+50.00

LEGEND

- (XXX) INPLACE TOPOGRAPHY AND REMOVAL PLAN SHEET NUMBER
- XXX CONSTRUCTION PLAN SHEET NUMBER
- <XXX> STORM DRAINAGE PLAN SHEET NUMBER



NO	DATE	BY	CKD	APPR	REVISION

NAME: P:\02-621-10\Plan\0262110_GEN.dgn 1:35:35 PM

I HEREBY CERTIFY THAT THIS PLAN WAS PREPARED BY ME OR UNDER MY DIRECT SUPERVISION AND THAT I AM A DULY LICENSED PROFESSIONAL ENGINEER UNDER THE LAWS OF THE STATE OF MINNESOTA.

PRINT NAME: CURT A. KOBILARCSIK
SIGNATURE: *Curt Kobilarsik*
DATE: 7-14-14 LICENSE NO. 24756

DRAWN BY: ZB DATE: 07-07-14
DESIGN BY: MN DATE: 07-07-14
CHECKED BY: CAK DATE: 07-11-14

ANOKA COUNTY
HIGHWAY DEPT.

S.A.P. 002-621-010

GENERAL LAYOUT

Sheet 2 of 147 Sheets

STATEMENT OF ESTIMATED QUANTITIES

TAB	NOTE	ITEM NO.	ITEM DESCRIPTION	UNIT	TOTAL PROJECT QUANTITY	STATE AID PARTICIPATING FUNDS		NON PARTICIPATING LOCAL FUNDS	
						COUNTY OF ANOKA SAP 002-621-010	STORM SEWER SAP 002-621-010	COUNTY OF ANOKA	CITY OF CENTERVILLE
		2021.501	MOBILIZATION	LUMP SUM	0.96		0.878	0.081	
		2031.501	FIELD OFFICE TYPE D	EACH	0.96		0.878	0.081	
		2041.610	TRAINEES	HOURL	1	1			
A	(1),(2)	2101.501	CLEARING	ACRE	1	0.65			
A	(1),(2),(1)	2101.502	CLEARING	TREE	266	232			34
A	(1),(2)	2101.506	GRUBBING	ACRE	1	0.65			
A	(1),(2),(1)	2101.507	GRUBBING	TREE	242	208			34
C	(2)(3)(14)	2104.501	REMOVE PIPE CULVERTS	LIN FT	1,555			1,555	
	(15)	2104.501	REMOVE PIPE SEWERS(SANITARY)	LIN FT	60				60
C	(2)	2104.501	REMOVE SEWER PIPE	LIN FT	394			394	
B	(2)	2104.501	REMOVE CURB AND GUTTER	LIN FT	1,014	1014			
Q	(2)	2104.501	REMOVE BITUMINOUS CURB	LIN FT	66	66			
F	(2)	2104.501	REMOVE FENCE	LIN FT	233	233			
B	(2)	2104.503	REMOVE BITUMINOUS WALK	SQ FT	1,201	1201			
B	(2)	2104.503	REMOVE CONCRETE WALK	SQ FT	5,322	5322			
D	(2)	2104.505	REMOVE CONCRETE DRIVEWAY PAVEMENT	SQ YD	123	123			
B,D	(2)	2104.505	REMOVE BITUMINOUS PAVEMENT	SQ YD	12,718	12718			
C	(2)	2104.509	REMOVE PIPE APRON	EACH	53			53	
C	(2)	2104.509	REMOVE HEAD WALL	EACH	1			1	
C	(2)	2104.509	REMOVE MANHOLE OR CATCH BASIN	EACH	18			18	
R	(2)	2104.509	REMOVE BITUMINOUS FLUME	EACH	1	1			
I	(2)	2104.509	REMOVE MAIL BOX SUPPORT	EACH	23	23			
B,D	(6)	2104.511	SAWING CONCRETE PAVEMENT (FULL DEPTH)	LIN FT	68	68			
B,D	(6)	2104.513	SAWING BITUMINOUS PAVEMENT (FULL DEPTH)	LIN FT	1,121	1121			
M	(4)	2104.523	SALVAGE SIGN TYPE C	EACH	38	4			34
M		2104.523	SALVAGE SIGN TYPE D	EACH	5	5			
M		2104.523	SALVAGE SIGN TYPE SPECIAL	EACH	7	7			
	(14)	2104.523	SALVAGE CASTING	EACH	1				1
	(14)	2104.523	SALVAGE MANHOLE	EACH	1				1
	(4)	2104.601	HAUL SALVAGED MATERIAL	LUMP SUM	1			1	
V	(7),(8)	2105.501	COMMON EXCAVATION (EV)	CU YD	18,412	18412			
V	(8)	2105.505	MUCK EXCAVATION	CU YD	356				356
V	(8)	2105.507	SUBGRADE EXCAVATION (EV)	CU YD	9,276	9276			
V	(8)	2105.522	SELECT GRANULAR BORROW (LV)	CU YD	15,604	13641			1,963
	(14)	2105.601	COMMON CHANNEL EXCAVATION	LS	1				0.25
L,S		2105.604	GEOTEXTILE FABRIC TYPE IV	SY	134	100			34
	(9)	2123.509	DOZER	HOURL	20	20			
	(10)	2130.501	WATER	M GALLON	350	350			
D,K,G1		2211.501	AGGREGATE BASE CLASS 5	TON	873	342			531
J	(5)	2211.503	AGGREGATE BASE (CV) CLASS 5	CU YD	6,732	6732			
B		2232.501	MILL BITUMINOUS SURFACE	SQ YD	1,840	1840			
B	(16)	2331.604	BITUMINOUS PAVEMENT RECLAMATION	SQ YD	6,892	6892			
J		2357.502	BITUMINOUS MATERIAL FOR TACK COAT	GALLON	1,870	1870			
D,K,G1		2360.501	TYPE SP 12.5 WEARING COURSE MIX (2,B)	TON	457	151			306
J		2360.501	TYPE SP 12.5 WEARING COURSE MIX (3,F)	TON	4,299	4299			
J		2360.502	TYPE SP 12.5 NON WEAR COURSE MIX (3,B)	TON	7,799	7799			
J		2360.505	TYPE SP 12.5 BITUMINOUS MIXTURE FOR PATCHING	TON	12	12			
T	(11)	2451.509	AGGREGATE BEDDING (CV)	CU YD	601	23		578	
U		2451.513	FINE FILTER AGGREGATE (LV)	CU YD	201	201			
		2451.607	TRENCH STABILIZATION MATERIAL (CV)	CU YD	250	250			
L		2501.511	15" RC PIPE CULVERT CLASS III	LIN FT	164			164	
L		2501.511	24" RC PIPE CULVERT CLASS III	LIN FT	98			98	
L	(14)	2501.511	48" RC PIPE CULVERT CLASS V	LIN FT	72			72	
L		2501.515	15" RC PIPE APRON	EACH	8			8	
S		2501.515	18" RC PIPE APRON	EACH	1			1	
L,S		2501.515	24" RC PIPE APRON	EACH	3			3	
S		2501.515	30" RC PIPE APRON	EACH	1			1	
S		2501.515	36" RC PIPE APRON	EACH	1			1	
L	(14)	2501.515	48" RC PIPE APRON	EACH	2			2	
S		2501.515	54" RC PIPE APRON	EACH	1			1	
L		2501.602	TRASH GUARD FOR 15" PIPE APRON	EACH	8			8	
L		2501.602	TRASH GUARD FOR 24" PIPE APRON	EACH	2			2	
L		2501.602	TRASH GUARD FOR 30" PIPE APRON	EACH	1			1	
L		2501.602	TRASH GUARD FOR 36" PIPE APRON	EACH	1			1	
U	(13)	2502.541	4" PERF TP PIPE DRAIN	LIN FT	5,964	5964			

01	7-21-14	ZB	MN		MNDOT COMMENTS
NO	DATE	BY	CKD	APPR	REVISION

I HEREBY CERTIFY THAT THIS PLAN WAS PREPARED BY ME OR UNDER MY DIRECT SUPERVISION AND THAT I AM A DULY LICENSED PROFESSIONAL ENGINEER UNDER THE LAWS OF THE STATE OF MINNESOTA.
 PRINT NAME: CURTA KOBLARCSIK
 SIGNATURE: *[Signature]*
 DATE: 7-22-14 LICENSE NO. 24756

DRAWN BY: ZB DATE: 07-07-14
 DESIGN BY: MN DATE: 07-07-14
 CHECKED BY: CAK DATE: 07-11-14



**ANOKA COUNTY
HIGHWAY DEPT.**

S.A.P. 002-621-010

STATEMENT OF ESTIMATED QUANTITIES
 Sheet 3 of 147 Sheets

STATEMENT OF ESTIMATED QUANTITIES

TAB	NOTE	ITEM NO.	ITEM DESCRIPTION	UNIT	TOTAL PROJECT QUANTITY	STATE AID PARTICIPATING FUNDS		NON PARTICIPATING LOCAL FUNDS	
						COUNTY OF ANOKA SAP 002-621-010	SAP 002-621-010	COUNTY OF ANOKA	CITY OF CENTERVILLE
S		2503.541	12" RC PIPE SEWER DESIGN 3006 CL V	LIN FT	31			31	
S		2503.541	15" RC PIPE SEWER DESIGN 3006 CL V	LIN FT	1,803			1,803	
S		2503.541	18" RC PIPE SEWER DESIGN 3006 CL III	LIN FT	352			352	
S		2503.541	21" RC PIPE SEWER DESIGN 3006 CL III	LIN FT	926			926	
S		2503.541	24" RC PIPE SEWER DESIGN 3006 CL III	LIN FT	108			108	
S		2503.541	30" RC PIPE SEWER DESIGN 3006 CL III	LIN FT	238			238	
S		2503.541	36" RC PIPE SEWER DESIGN 3006 CL III	LIN FT	457			457	
S		2503.541	42" RC PIPE SEWER DESIGN 3006 CL III	LIN FT	49			49	
S		2503.541	48" RC PIPE SEWER DESIGN 3006 CL III	LIN FT	1,780			1,780	
S		2503.541	54" RC PIPE SEWER DESIGN 3006 CL V	LIN FT	42			42	
	(12)	2503.601	LOWER FORCE MAIN	LS	1	0.75			0.25
	(14)	2503.602	CONNECT TO EXISTING MANHOLE (SANITARY)	EACH	3				3
S		2503.602	CONNECT TO EXISTING STORM SEWER	EACH	4	2			2
C		2503.602	PLUG & ABANDON PIPE SEWER	EACH	3			3	
	(14)	2503.603	SEWER INSPECTION	LIN FT	1,283				1,283
	(14)	2503.603	SANITARY SEWER SERVICE	LIN FT	336				336
	(14)	2503.603	8" PVC PIPE SEWER	LIN FT	1,223				1,223
	(14)	2503.603	12" PVC PIPE SEWER	LIN FT	60				60
	(14)	2504.602	CONNECT TO EXISTING WATERMAIN	EACH	4				4
EE		2504.602	RELOCATE HYDRANT	EACH	1	1			
EE		2504.602	RELOCATE HYDRANT AND VALVE	EACH	2	2			
	(14)	2504.602	INSTALL HYDRANT AND VALVE	EACH	2				2
EE		2504.602	ADJUST GATE VALVE AND BOX	EACH	20	20			
	(14)	2504.602	1" CORPORATION STOP	EACH	9				9
	(14)	2504.602	6"X8" TEE FITTING	EACH	1				1
	(14)	2504.602	8"X8" TEE FITTING	EACH	2				2
	(14)	2504.602	8"X8" TEE FITTING	EACH	1				1
	(14)	2504.602	8" PIPE BEND 45 DEGREE	EACH	4				4
	(14)	2504.602	6" GATE VALVE AND BOX	EACH	2				2
	(14)	2504.602	8" GATE VALVE AND BOX	EACH	1				1
	(14)	2504.602	6" MEGALUG	EACH	15				15
	(14)	2504.602	8" MEGALUG	EACH	16				16
	(14)	2504.602	12" MEGALUG	EACH	1				1
	(14)	2504.602	1" CURB STOP AND BOX	EACH	9				9
	(14)	2504.602	8"X8" REDUCER	EACH	1				1
	(14)	2504.602	12"X8" REDUCER	EACH	1				1
	(14)	2504.603	WATER SERVICE	LIN FT	175				175
	(14)	2504.603	HYDRANT RISER	LIN FT	2				2
	(14)	2504.603	6" PVC WATERMAIN	LIN FT	550				550
	(14)	2504.603	8" PVC WATERMAIN	LIN FT	1,445				1,445
		2504.604	2" POLYSTYRENE INSULATION	SY	25			25	
	(14)	2505.606	PIPELINE CASING FILLER	GAL	6,500				6,500
S		2506.501	CONST. DRAINAGE STRUCTURE DESIGN H	LIN FT	81			80.5	
S		2506.501	CONST. DRAINAGE STRUCTURE DESIGN 48-4020	LIN FT	83			82.5	
S		2506.501	CONST. DRAINAGE STRUCTURE DESIGN 54-4020	LIN FT	3			3.4	
S		2506.501	CONST. DRAINAGE STRUCTURE DESIGN 60-4020	LIN FT	27			26.6	
S		2506.501	CONST. DRAINAGE STRUCTURE DESIGN 66-4020	LIN FT	5			4.5	
S		2506.501	CONST. DRAINAGE STRUCTURE DESIGN 72-4020	LIN FT	75			74.9	
S		2507.501	CONST. DRAINAGE STRUCTURE DESIGN 78-4020	LIN FT	14			13.9	
S		2506.501	CONST. DRAINAGE STRUCTURE DESIGN 96-4020	LIN FT	9			9.0	
S		2507.501	CONST. DRAINAGE STRUCTURE DESIGN 102-4020	LIN FT	16			16.1	
S		2506.501	CONST. DRAINAGE STRUCTURE DESIGN 120-4020	LIN FT	9			9.1	
S	(17)	2506.516	CASTING ASSEMBLY	EACH	66			66.0	
	(14)	2506.521	INSTALL CASTING	EACH	1				1
H		2506.522	ADJUST FRAME AND RING CASTING	EACH	16	12			4
	(14)	2506.602	INSTALL MANHOLE	EACH	1				1
	(14)	2506.602	CONST DRAINAGE STRUCTURE DESIGN SPECIAL	EACH	5				5
L		2511.501	RANDOM RIPRAP CLASS II	CU YD	6	6			
L		2511.501	RANDOM RIPRAP CLASS III	CU YD	76	57			19
S		2511.501	RANDOM RIPRAP CLASS IV	CU YD	62	46			16
L		2511.515	GEOTEXTILE FILTER TYPE III	SQ YD	30	30			
O		2521.501	4" CONCRETE WALK	SQ FT	552	552			
O		2531.501	CONCRETE CURB & GUTTER DESIGN B424	LIN FT	7,075	3538			3,538
O		2531.501	CONCRETE CURB & GUTTER DESIGN B618	LIN FT	89	89			
D,G1		2531.507	6" CONCRETE DRIVEWAY PAVEMENT	SQ YD	308	308			
L1		2531.604	CONCRETE DRAINAGE FLUME	SQ YD	6	6			
O		2531.618	TRUNCATED DOMES	SQ FT	200	164			36
O		2531.618	PEDESTRIAN CURB RAMP	SQ FT	714	570			144
Q		2535.501	BITUMINOUS CURB	LIN FT	36	36			

01	7-21-14	ZB	MN	MNDOT COMMENTS
NO	DATE	BY	CKD	APPR
REVISION				07/22/2014 8:09:51 AM

I HEREBY CERTIFY THAT THIS PLAN WAS PREPARED BY ME OR UNDER MY DIRECT SUPERVISION AND THAT I AM A DULY LICENSED PROFESSIONAL ENGINEER UNDER THE LAWS OF THE STATE OF MINNESOTA.

PRINT NAME: CURT A. KOBILARCSIK
 SIGNATURE: *Curt A. Kobilarsik*
 DATE: 7-22-14 LICENSE NO. 24756

DRAWN BY: ZB DATE: 07-07-14
 DESIGN BY: MN DATE: 07-07-14
 CHECKED BY: CAK DATE: 07-11-14



**ANOKA COUNTY
HIGHWAY DEPT.**

S.A.P. 002-621-010

STATEMENT OF
ESTIMATED QUANTITIES

STATEMENT OF ESTIMATED QUANTITIES

TAB	NOTE	ITEM NO.	ITEM DESCRIPTION	UNIT	TOTAL PROJECT QUANTITY	STATE AID PARTICIPATING FUNDS		NON PARTICIPATING LOCAL FUNDS	
						COUNTY OF ANOKA SAP 002-621-010	STORM SEWER SAP 002-621-010	COUNTY OF ANOKA	CITY OF CENTERVILLE
I		2540.602	INSTALL MAIL BOX SUPPORT	EACH	23	23			
I		2540.602	RELOCATE MAIL BOX SUPPORT	EACH	1	1			
		2563.601	TRAFFIC CONTROL	LUMP SUM	1	0.88	0.081		
		2563.610	POLICE OFFICER	HOUR	2	2			
E		2564.531	SIGN PANELS TYPE C	SQ FT	419	419			
M		2564.536	INSTALL SIGN PANEL TYPE C	EACH	4	4			
M		2564.536	INSTALL SIGN PANEL TYPE D	EACH	5	5			
M		2564.537	INSTALL SIGN TYPE SPECIAL	EACH	7	7			
		2564.602	CULVERT MARKER X4-3	EACH	7	7			
P		2573.502	SILT FENCE, TYPE MACHINE SLICED	LIN FT	5,040	5040			
	(15)	2573.505	FLOTATION SILT CURTAIN TYPE MOVING WATER	LIN FT	90	90			
P		2573.530	STORM DRAIN INLET PROTECTION	EACH	70	70			
	(14)	2573.540	FILTER LOG TYPE ROCK LOG	LIN FT	110	82			28
		2573.550	EROSION CONTROL SUPERVISOR	LUMP SUM	1	0.75			0
P		2575.501	SEEDING (P)	ACRE	4	4			
P		2575.502	SEED MIXTURE 250	POUND	91	91			
P		2575.502	SEED MIXTURE 310	POUND	218	215			3
L,P		2575.505	SODDING TYPE SALT RESISTANT	SQ YD	10,775	10775			
P		2575.511	MULCH MATERIAL TYPE 1	TON	3	3			
P		2575.519	DISK ANCHORING (P)	ACRE	2	2			
P		2575.523	EROSION CONTROL BLANKETS CATEGORY 00	SQ YD	11,758	11758			
P	(14)	2575.523	EROSION CONTROL BLANKETS CATEGORY 4	SQ YD	1,800	1350			450
P		2575.532	FERTILIZER TYPE 3	POUND	1,188	1188			
P		2575.532	FERTILIZER TYPE 4	POUND	402	394			8
P		2575.571	RAPID STABILIZATION METHOD 3	M GALLON	16	15			1
		2582.502	24" SOLID LINE WHITE - PREFORMED THERMOPLASTIC	LIN FT	56	56			
		2582.502	24" SOLID LINE YELLOW - PREFORMED THERMOPLASTIC	LIN FT	420	420			
		2582.502	4" SOLID LINE WHITE - EPOXY	LIN FT	15,350	15350			
		2582.502	4" SOLID LINE YELLOW - EPOXY	LIN FT	1,290	1290			
		2582.502	4" BROKEN LINE YELLOW - EPOXY	LIN FT	350	350			
		2582.502	4" DOUBLE SOLID LINE YELLOW - EPOXY	LIN FT	15,340	15340			
		2582.503	CROSSWALK MARKING - WHITE PREFORMED THERMOPLASTIC	SQ FT	234	234			

NOTES:

- | | |
|--|--|
| <p>(1) CLEARING AND GRUBBING SHALL BE STAKED IN FIELD BY THE ENGINEER.</p> <p>(2) ALL REMOVAL ITEMS SHALL BE DISPOSED OFF-SITE. NO DISPOSAL SHALL BE ALLOWED WITHIN THE ROADWAY RIGHT-OF-WAY OR EASEMENTS.</p> <p>(3) REMOVAL INCLUDES ALL TYPES OF PIPES AND CMP APRONS.</p> <p>(4) SALVAGE TO: ANOKA COUNTY HIGHWAY DEPT, 1440 BUNKER LAKES BLVD NW, ANDOVER, MN. SALVAGE MAIL BOX SUPPORT TO OWNER.</p> <p>(5) INCLUDED 5" AGGREGATE CL-5 TOP OF RECLAMATION SURFACE</p> <p>(6) PAYMENT FOR SAWING BITUMINOUS WILL ONLY BE PAID WHEN THE CUT IS MADE WITH A SAW. NO PAYMENT SHALL BE MADE FOR CUTS MADE BY A MILLING MACHINE OR RECLAIMER.</p> <p>(7) INCLUDES INPLACE TOPSOIL AND BITUMINOUS PAVEMENT LESS THAN 6" THICK. BITUMINOUS MATERIAL SHALL BE DISPOSED OUTSIDE THE ROADWAY RIGHT-OF-WAY.</p> <p>(8) MUCK EXCAVATION FOR DITCH AREA ON EAST SIDE OF ROAD FOR STATIONS 142+50 TO 146+80 AND 151+00 TO 152+30. (SEE SOILS AND CONSTRUCTION NOTES.)</p> | <p>(9) SHALL BE USED FOR MISCELLANEOUS GRADING ACTIVITIES AS DIRECTED BY THE ENGINEER.</p> <p>(10) WATER TO BE USED ONLY FOR DUST CONTROL AS DIRECTED BY THE ENGINEER IN FIELD. WATER USED FOR COMPACTION AND TURF ESTABLISHMENT SHALL BE INCIDENTAL.</p> <p>(11) BEDDING FOR 36", 42", 48", 54" RC PIPE</p> <p>(12) LOWERING SANITARY SEWER FORCEMAIN PIPE AT APPROXIMATE STA 143+61</p> <p>(13) SEE SHEET 18 FOR DETAIL</p> <p>(14) SEE SHEETS 70 TO 78 FOR DETAIL (CITY CENTERVILLE PLAN SHEETS)</p> <p>(15) QUANTITY TO BE USED IN COUNTY DITCH</p> <p>(16) 2105.607 HAUL BITUMINOUS MATERIAL (LV) CONSIDERED INCIDENTAL TO BITUMINOUS PAVEMENT RECLAMATION</p> <p>(17) SEE DRAINAGE DETAILS SHEET 61 FOR DETAILS</p> <p>(P) PLAN QUANTITY</p> |
|--|--|

01	7-21-14	ZB	MN	MNDOT COMMENTS	I HEREBY CERTIFY THAT THIS PLAN WAS PREPARED BY ME OR UNDER MY DIRECT SUPERVISION AND THAT I AM A DULY LICENSED PROFESSIONAL ENGINEER UNDER THE LAWS OF THE STATE OF MINNESOTA. PRINT NAME: CURT A. KOBIARCSIK SIGNATURE: <i>Curt A. Kobiarcsik</i> DATE: 7-22-14 LICENSE NO. 24756	DRAWN BY: ZB DATE: 07-07-14 DESIGN BY: MN DATE: 07-07-14 CHECKED BY: CAK DATE: 07-11-14	 ANOKA COUNTY HIGHWAY DEPT.	S.A.P. 002-621-010	STATEMENT OF ESTIMATED QUANTITIES Sheet <u>5</u> of <u>147</u> Sheets
NO DATE BY CKD APPR REVISION NAME: P:\02-621-10\Plan2_SEQ.dgn 07/21/2014 10:56:15 AM									

THE FOLLOWING STANDARD PLATES AS APPROVED BY THE FEDERAL HIGHWAY ADMINISTRATION SHALL APPLY.

PLATE NO.	STANDARD PLATES
3000L	REINFORCED CONCRETE PIPE (5 SHEETS)
3006G	GASKET JOINT FOR R.C. PIPE (2 SHEETS)
3007E	SHEAR REINFORCEMENT FOR PRECAST DRAINAGE STRUCTURES
3014J	REINFORCED CONCRETE PIPE ARCH (2 SHEETS)
3100G	CONCRETE APRON FOR REINFORCED CONCRETE PIPE
3133D	RIPRAP AT RCP OUTLETS
3145G	CONCRETE PIPE TIES
4006L	MANHOLE OR CATCH BASIN PRECAST - DESIGNS G AND H
4010H	CONCRETE SHORT CONE & ADJUSTING RING (SECTIONAL CONCRETE)
4011E	PRECAST CONCRETE BASE
4018B	MANHOLE OR CATCH BASIN COVER DESIGN D
4020J	MANHOLE OR CATCH BASIN FOR USE WITH OR WITHOUT TRAFFIC LOADS (2 SHEETS)
4026A	CONCRETE ENCASED CONCRETE ADJUSTING RINGS
4101D	RING CASTING FOR MANHOLE OR CATCH BASIN
4110F	COVER CASTING FOR MAHNOLE - CASTING NO. 715 AND 716
4125D	CATCH BASIN FRAME CASTING (FOR SQUARE GRATE) - CASTING NO. 715 AND 716
4132F	CATCH BASIN FRAME CASTING - CASTING NO. 806
4134A	CURB BOX CASTING FOR CATCH BASIN - CASTING NO. 825
4140D	SPECIAL GRATE CASTING FOR CATCH BASIN - CASTING NO. 720 AND 721
4154B	CATCH BASIN GRATE CASTING - CASTING NO. 816
4180J	MANHOLE OR CATCH BASIN STEP
7035N	CONCRETE WALK AND CURB RETURNS AT ENTRANCES
7038A	DETECTABLE WARNING SURFACE TRUNCATED DOMES
7100H	CONCRETE CURB AND GUTTER (DESIGN B AND DESIGN V)
7109C	MEDIAN NOSE AND ISLAND
7111J	INSTALLATION OF CATCH BASIN CASTINGS (CONCRETE CURB AND GUTTER)
7113A	CONCRETE APPROACH NOSE DETAIL
8000I	STANDARD BARRICADE
8150C	INSTALLATION OF CULVERT MARKERS
9102E	TURF ESTABLISHMENT AREA (AT PIPE CULVERT ENDS)
9350A	MAILBOX SUPPORT (SWING-AWAY TYPE)

GENERAL NOTES:

ALL UTILITY WORK SHOWN ON THIS SHEET SHALL BE DONE BY OTHERS UNLESS NOTED.

ALL RELOCATES AND ADJUSTMENTS SUBJECT TO ANOKA COUNTY, CITY OF LINO LAKES AND/OR CITY OF CENTERVILLE RIGHT OF WAY.

IT SHALL BE THE CONTRACTOR'S RESPONSIBILITY TO UTILIZE THE GOPHER STATE ONE CALL EXCAVATION NOTICE SYSTEM REQUIRED BY MINNESOTA STATUTE, CHAPTER 216D FOR ALL UNDERGROUND UTILITY LOCATIONS.

THE SUBSURFACE UTILITY INFORMATION IN THIS PLAN IS UTILITY QUALITY LEVEL D. THIS UTILITY QUALITY LEVEL WAS DETERMINED ACCORDING TO THE GUIDELINES OF CI/ASCE 38-02, ENTITLED "STANDARD GUIDELINES FOR THE COLLECTION AND DEPICTION OF EXISTING SUBSURFACE UTILITY DATA".

THE REMARKS COLUMN IS BASED UPON THE BEST INFORMATION AVAILABLE AND MAY NOT REFLECT THE ACTUAL EFFECTS ON THE UTILITES BY CONSTRUCTION. ACTUAL DETERMINATIONS WILL BE MADE IN THE FIELD DURING CONSTRUCTION.

INDEX OF TABULATIONS		
TAB	SHEET	DESCRIPTION
A	7	CLEARING AND GRUBBING
B	7	BITUMINOUS AND CONCRETE REMOVALS, SAWING AND MILLING
C	8	EXISTING STORM SEWER & CULVERT REMOVAL
D	8	DRIVEWAY REMOVAL AND CONSTRUCTION
E	97	SIGN PANELS TYPE C
F	8	FENCING
G	16	EARTHWORK TABULATION
G1	9	TURNAROUND CONSTRUCTION
H	9	SANITARY/STORM SEWER ADJUSTMENTS
I	9	MAILBOXES
J	9	BASE AND BITUMINOUS QUANTITIES
K	10	CONSTRUCT BITUMINOUS TRAIL
L	10	CULVERT TABULATION
L1	10	CONCRETE DRAINAGE FLUME
M	85	SALVAGE SIGNS
O	11	CONCRETE CURB AND GUTTER, MEDIAN, WALK
P	11	TURF ESTABLISHMENT AND EROSION CONTROL
Q	11	BITUMINOUS CURB REMOVAL AND CONSTRUCTION
R	11	MISCELLANEOUS REMOVALS
S	58-59	DRAINAGE TABULATION
T	12	AGGREGATE BEDDING
U	12	SUBSURFACE DRAINAGE
V	17	EARTHWORK BALANCE
	93	PERMANENT PAVEMENT MARKING
AA	12	UTILITY CONTACTS
BB	13	CONNEXUS ENERGY
CC	13	COMCAST CABLE
DD	14	CENTERPOINT ENERGY
EE	15	CITY OF CENTERVILLE
FF	15	CENTURYLINK
GG	15	ZAYO BANDWIDTH

BASIS OF QUANTITIES		
SPEC NO	DESCRIPTION	RATE
2211	AGGREGATE BASE CLASS 5	2 TONS / CU YD
2357	BITUMINOUS MATERIAL FOR TACK COAT	0.05 GALLONS / SQ YD / LIFT
2360	TYPE SP12.5 WEARING COURSE MIXTURE	115 POUNDS / SQ YD / IN
2360	TYPE SP12.5 NON-WEARING COURSE MIXTURE	115 POUNDS / SQ YD / IN
2575	SEED MIXTURE 310	82.0 POUNDS / ACRE
2575	SEED MIXTURE 250	70.0 POUNDS / ACRE
2575	SEED MIXTURE 350	84.5 POUNDS / ACRE
2575	MULCH MATERIAL TYPE 1	2 TONS / ACRE
2575	FERTILIZER TYPE 3, 22-5-10 FOR SOD	350 POUNDS / ACRE
2575	FERTILIZER TYPE 4, 18-1-8 FOR SEED MIX 350	150 POUNDS / ACRE
2575	RAPID STABILIZATION METHOD 3	6000 GALLONS / ACRE

NO	DATE	BY	CKD	APPR	REVISION
01	7-21-14	ZB	MN		MNDOT COMMENTS

I HEREBY CERTIFY THAT THIS PLAN WAS PREPARED BY ME OR UNDER MY DIRECT SUPERVISION AND THAT I AM A DULY LICENSED PROFESSIONAL ENGINEER UNDER THE LAWS OF THE STATE OF MINNESOTA.
 PRINT NAME: CURT A. KOBIARCSIK
 SIGNATURE: *[Signature]*
 DATE: 7-22-14 LICENSE NO. 24756

DRAWN BY: ZB DATE: 07-07-14
 DESIGN BY: MN DATE: 07-07-14
 CHECKED BY: CAK DATE: 07-11-14



ANOKA COUNTY
 HIGHWAY DEPT.

S.A.P. 002-621-010

STANDARD PLATES
 BASIS OF QUANTITIES
 INDEX OF TABULATIONS
 Sheet 6 of 147 Sheets

CLEARING & GRUBBING SPEC (2101)						A	
STATION TO STATION	LOCATION		CLEARING		GRUBBING		NOTES
	C/L OFFSET		(TREE)	(ACRE)	(TREE)	(ACRE)	
CSAH 21 CL							
99+35	39 RT		1		1		
107+46	40 RT		5		1		
108+52	44 RT		1		1		
108+97	109+47	29 RT 45 RT		0.05		0.05	
113+46	40 RT		1		1		
113+71	22 RT		1		1		
113+73	33 RT		1		1		
113+83	35 RT		1		1		
114+05	37 RT		1		1		
115+55	44 RT		1		1		
115+75	37 RT		1		1		
120+74	56 RT		1		1		
122+88	57 RT		1		1		
124+08	124+14	57 RT 57 RT	4		4		
128+28	124+35	57 RT 57 RT	3		3		
124+38	31 RT		1		1		
124+48	125+34	50 RT 58 RT		0.10		0.10	
125+74	126+07	53 RT 59 RT		0.05		0.05	
126+53	127+17	47 RT 59 RT		0.05		0.05	
127+48	45 RT		4		1		
127+95	128+36	49 RT 49 RT	3		3		
128+75	49 RT				1		
128+84	49 RT		1		1		
128+99	129+39	49 RT 49 RT			5		
129+45	130+04	44 RT 41 RT	6		6		
129+55	130+15	38 RT 53 RT		0.05		0.05	
130+52	43 RT		1		1		
130+69	132+48	36 RT 61 RT		0.15		0.15	
132+79	51 RT		1		1		
132+79	55 RT		1		1		
141+06	141+83	60 RT 62 RT	10		10		
142+23	62 RT		1		1		
146+59	146+81	42 RT 46 RT	2		2		
147+10	44 RT	42 RT	2		2		
149+80	48 RT		1		1		

CLEARING & GRUBBING SPEC (2101)						A	
STATION TO STATION	LOCATION		CLEARING		GRUBBING		NOTES
	C/L OFFSET		(TREE)	(ACRE)	(TREE)	(ACRE)	
104+70	39 LT		1		1		
106+27	32 LT		3		1		
106+65	108+04	23 LT 47 LT		0.15		0.15	
115+40	46 LT		1		1		
115+44	58 LT		1		1		
118+01	118+03	28 LT 30 LT	2		2		
119+49	29 LT		1		1		
120+66	59 LT		1		1		
120+99	34 LT		1		1		
121+20	121+32	34 LT 33 LT	2		2		
121+81	33 LT		1		1		
122+02	47 LT		4		1		
122+83	123+00	49 LT 50 LT	2		2		
124+62	37 LT		1		1		
126+37	126+64	49 LT 35 LT	6		4		
128+65	128+89	46 LT 54 LT	3		2		
129+26	129+59	57 LT 55 LT	10		6		
131+27	131+97	50 LT 52 LT	11		8		
132+04	132+81	42 LT 55 LT		0.05		0.05	
133+37	32 LT		1		1		
135+13	417 LT		109		109		COUNTY DITCH
135+13	90 LT		15		15		PARK TRAIL CL (1)
135+13	90 RT		13		13		PARK TRAIL CL (1)
138+58	51 LT		1		1		
138+95	41 LT		2		1		
139+07	48 LT		1		1		
139+66	44 LT		1		1		
140+49	45 LT		1		1		
142+05	142+13	36 LT 35 LT	2		2		
143+43	143+52	35 LT 34 LT	2		2		
149+65	38 LT		1		1		
150+29	35 LT		5		1		
151+88	42 LT		4		1		
TOTAL			266	0.65	242	0.65	

(1) THE LT/RT OFFSET GIVEN IS FROM THE CENTERLINE OF THE PARK TRAIL, NOT CSAH 21

BITUMINOUS AND CONCRETE REMOVALS, SAWING AND MILLING											B	
STATION TO STATION	LOCATION		DESCRIPTION	BIT PAVEMENT RECLAMATION (SQ YD) (SPEC 2331)	REMOVE (SPEC. 2104)					SAWING (SPEC. 2104)		MILL (SPEC. 2232)
					BITUMINOUS PAVEMENT	BITUMINOUS WALK	CONCRETE WALK	(1) CONCRETE PEDESTRIAN RAMP	CONC. CURB & GUTTER	BITUMINOUS PAVEMENT	CONCRETE PAVEMENT	BITUMINOUS SURFACE (2")
					SQ YD	SQ FT	SQ FT	SQ FT	LIN FT	LIN FT	LIN FT	SQ YD
92+74.24	93+40.85	LT CL			161					193		
93+40.85	98+55.82	LT - RT CL	RECLAIM	1,563								
98+55.82	110+00.00	LT - RT CL	RECLAIM	3,132								
110+00.00	118+10.00	LT - RT CL	RECLAIM	2,197								
118+10.00	130+38.55	LT - RT CL			3,290							
126+42.00		LT - RT CL	CITY TRAIL			815				19		
130+38.55	137+62.71	LT - RT CL			1,976							
137+62.71	144+28.91	LT - RT CL			1,893							
143+95.12	144+25.77	LT CL				336				8		
144+28.91	152+94.13	LT - RT CL			2,408				23			
144+67.48	149+99.31	RT CL					2,699	18				
144+77.00		LT CL						61				
150+24.47	152+23.91	RT CL					923	84				
152+94.13	155+85.81	LT CL	RT. TRN LN		304			106	323	396		
152+94.13	155+55.55	LT - RT CL	BIT MILLING								899	
155+55.55	156+20.00	LT - RT CL	RECLAIM	367		50	348		92	163	16	
156+20.00	158+50.00	LT - RT CL	BIT MILLING									941
120+06.00		LT - RT CL	DUPRE ROAD		567		991		124	87	9	
130+70.00		LT CL	HUNTERS TRAIL		470				94	95		
137+75.00		RT CL	CENTER ST.		266				94	30		
144+46.00		LT - RT CL	MEADOW LANE		434				77	63		
150+12.00			PRIVATE ROAD		180				78	24		
152+34.00		LT - RT CL	HERITAGE ST.		280				109	52		
152+49.00	152+63.00	RT CL					43	49			5	
TOTAL				6,892	12,068	1,201	5,004	318	1,014	937	30	1,840

NOTES: (1) PAID FOR AS REMOVE CONCRETE WALK

01	7-21-14	ZB	MN		MNDOT COMMENTS
NO	DATE	BY	CKD	APPR	REVISION
NAME: P:\02-621-10\Plan2_SEQ.dgn 07/21/2014 10:56:29 AM					

I HEREBY CERTIFY THAT THIS PLAN WAS PREPARED BY ME OR UNDER MY DIRECT SUPERVISION AND THAT I AM A DULY LICENSED PROFESSIONAL ENGINEER UNDER THE LAWS OF THE STATE OF MINNESOTA.
 PRINT NAME: CURT A. KOBILARCSIK
 SIGNATURE: *Curt A. Kobilarsik*
 DATE: 7-22-14 LICENSE NO. 24756

DRAWN BY: ZB DATE: 07-07-14
 DESIGN BY: MN DATE: 07-07-14
 CHECKED BY: CAK DATE: 07-11-14

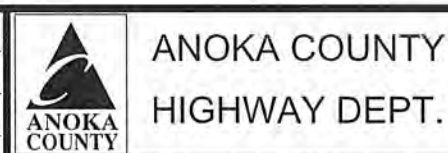

S.A.P. 002-621-010

TURNAROUND CONSTRUCTION						G1	
STATION TO STATION		LOC.		DISCRIPTION	CONC.	BIT.	AGG.
		LIN FT		LIN FT	SQ FT	SQ FT	SQ FT
108+54.00	108+72.00	70.0	LT - CL	10 x 18		184	
114+32.30	114+50.30	42.0	LT - CL	10 x 18	190		
127+26.30	127+44.30	106.0	RT - CL	12 x 18			220
136+44.60	136+62.60	65.0	LT - CL	12 x 18		219	
140+05.50	140+23.50	51.5	LT - CL	12 x 18		219	
140+54.00	140+72.00	47.3	LT - CL	12 x 18	225		
143+09.90	143+27.90	49.0	LT - CL	12 x 18			220
146+45.10	146+63.10	56.3	RT - CL	10 x 18		184	
150+47.40	150+65.40	58.8	LT - CL	12 x 18		219	
TOTAL					415	1025	440

NOTE: THESE QUANTITIES ARE INCLUDED IN TAB D ON PAGE 8

SANITARY/STORM SEWER ADJUSTMENTS								H	
STATION	LOCATION		SANITARY			STORM			NOTES
	ALIGN	OFFSET	EXISTING TOC	PROPOSED TOC	ADJUST EACH	EXISTING TOC	PROPOSED TOC	ADJUST EACH	
C.S.A.H 21									
124+21	21 CL	37.95 RT	909.63	911.11	1				
127+06	21 CL	43.97 RT	910.00	910.13	1				
130+36	21 CL	51.05 LT				910.43	910.80	1	CB
130+74	21 CL	31.69 RT	907.88	911.51	1				
131+03	21 CL	50.78 LT				910.52	910.60	1	CB
132+52	21 CL	73.98 RT	908.40	908.40					NOT DISTURBED
132+69	21 CL	38.1 RT	907.15	909.99	1				
134+82	21 CL	43.64 RT	902.61	908.46	1				
137+78	21 CL	28.36 RT	909.80	907.63	1				
141+80	21 CL	32.67 RT	908.20	909.77	1				
142+88	21 CL	23.67 RT	909.07	910.03	1				
143+00	21 CL	52.93 RT	908.51	909.01	1				
144+48	21 CL	32.48 RT	911.73	910.91	1				
144+50	21 CL	30.25 LT	912.00	911.02	1				
148+17	21 CL	30.67 LT	908.57	909.35	1				
151+62	21 CL	28.67 LT	905.51	907.23	1				
152+37	21 CL	0.81 RT	907.38	907.36	1				
TOTAL					14			2	

MAILBOX					I	
STATION	ALIGN.	OFFSET		REMOVE MAIL BOX SUPPORT (SPEC 2104) (EACH)	INSTALL MAIL BOX SUPPORT (SPEC 2540) (EACH)	RELOCATE MAIL BOX SUPPORT (SPEC 2540) (EACH)
97+15	CL	RT	18.00	1	1	
100+06	CL	RT	14.00	2	2	
108+77	CL	RT	18.00	2	2	
110+64	CL	RT	18.00	1	1	
113+18	CL	RT	18.00	1	1	
114+21	CL	RT	21.70	1	1	
123+91	CL	RT	27.00	1	1	
124+42	CL	RT	27.00	1	1	
126+21	CL	RT	27.00	1	1	
127+72	CL	RT	27.00	1	1	
130+39	CL	RT	27.00	1	1	
133+21	CL	RT	27.00	1	1	
138+00	CL	RT	27.00	1	1	
139+27	CL	RT	27.00	1	1	
140+31	CL	RT	27.00	1	1	
140+78	CL	RT	27.00	1	1	
143+02	CL	RT	27.00	1	1	
144+98	CL	RT	27.00			1
146+37	CL	RT	27.30	1	1	
150+73	CL	RT	22.70	3	3	
TOTAL				23	23	1

BASE AND BITUMINOUS QUANTITIES										J
STATION TO STATION		LOC.	DESCRIPTION	BITUMINOUS SURFACE	TYPE SP 12.5 WEAR (SPWEB340F)	TYPE SP 12.5 NON WEAR (SPNWB330B)	PATCHING TYPE SP 12.5 WEAR (SPWEB230B)	TACK COAT	AGGREGATE BASE CLASS 5	
										SQ YD
92+74.24	93+40.80	CL	PIPE CROSSING	161	19	31		8.1	31	
93+40.80	98+55.82	CL	5" TOP RECLAIM SURF.	2577	296	494		128.9	391	
98+55.82	110+00.00	CL	5" TOP RECLAIM SURF.	4068	468	643		203.4	638	
110+00.00	118+10.00	CL	5" TOP RECLAIM SURF.	3825	440	605		191.3	583	
118+10.00	118+10.00	CL	5" TOP RECLAIM SURF.	3825	440	605		191.3	531	
118+10.00	130+38.55	CL	BEG. CURB & GUTTER	7061	812	1827		353.1	1533	
130+38.55	137+62.71	CL		3701	426	958	12	185.1	814	
137+62.71	144+28.91	CL		3854	443	997		192.7	836	
144+28.91	152+94.13	CL		5673	652	1468		283.7	1216	
152+94.13	155+85.81	CL	RT.TN.LN.	435	50	113		21.8	104	
152+94.13	155+55.55	CL	2" MILL & OVERLAY	899	103			45.0		
155+55.55	156+20.00	CL	5" TOP RECLAIM SURF.	367	42	58		18.4	55	
156+20.00	158+50.00	CL	2" MILL & OVERLAY	941	108			47.1		
PROJECT TOTAL				112162	4,299.0	7,799.0	12.0	1,870	6,732.0	

NOTES:
(1) INCLUDES QUANTITY FOR ADDITIONAL 1/4 INCH TO DESIGN PAVEMENT THICKNESS.
(2) 5" AGGREGATE BASE CLASS 5 INCIDENTAL TO EXTENDED LANE AND PATCHING.
(3) INCLUDES QUANTITY FOR AGGREGATE SHOULDERING
SEE SHEET 6 FOR 'BASIS OF QUANTITIES'.
(4) TOTAL AGG TOP 5" RECLAIM SURFACE QUANTITY INCLUDED IN AGGREGATE BASE CL 5 PROJECT TOTAL

2,198.00
TOTAL AGG TOP 5" RECLAIM SURFACE

NO	DATE	BY	CKD	APPR	REVISION
NAME: P:\02-621-10\Plan2_SEO.dgn					

I HEREBY CERTIFY THAT THIS PLAN WAS PREPARED BY ME OR UNDER MY DIRECT SUPERVISION AND THAT I AM A DULY LICENSED PROFESSIONAL ENGINEER UNDER THE LAWS OF THE STATE OF MINNESOTA.
PRINT NAME: CURT A. KOBILARCSIK
SIGNATURE: *Curt A. Kobilarsik*
DATE: 7-12-14 LICENSE NO. 24755

DRAWN BY: ZB DATE: 07-07-14
DESIGN BY: MN DATE: 07-07-14
CHECKED BY: CAK DATE: 07-11-14

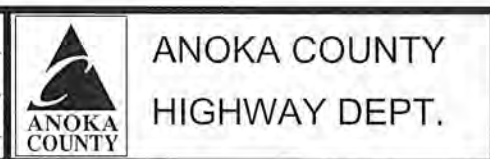

S.A.P. 002-621-010

CONSTRUCT BITUMINOUS TRAIL							K
STATION TO STATION	ALIGNMENT	OFFSET FACE CURB	SURFACE AREA	TYPE SP 12.5 2.5" WEAR (SPWEB230B)	4" AGG. CLASS-5	NOTES	
				SQ YD	TON		TON
120+32.20	137+46.87	RT CL	5' - 6'	1529.9	220	382	
126+52.77	126+53.35	RT - LT CL	VARIES	34.3	5	8	
138+02.25	144+15.54	RT CL	5' - 6'	545.0	78	136	
143+95.12	144+16.38	LT CL	5' - 6'	20.0	3	5	
PROPOSED BIT TRAIL SUBTOTAL					306	531	
144+65.01	149+86.49	RT CL	5' - 6'	465.5	67	116	
150+36.67	152+14.41	RT CL	5' - 6'	157.7	23	40	
155+65.57	155+75.96	RT CL	0	5.6	1	2	[4]
BIT. TRAIL, REPLACE EXISTING CONC. WALK SUBTOTAL					90	156	
PROJECT TOTAL					396	687	

GENERAL NOTES:

- [1] 2.5" BITUMINOUS PATH TYPE LV 4 WEARING COURSE MIXTURE (B)
4" AGGREGATE BASE SHALL BE INCIDENTAL TO BITUMINOUS PATH
- [2] BASED ON A BITUMINOUS PATH DEPTH OF 2.5"
- [3] AGGREGATE CL 5_1 CU.YD. = 2 TON
- [4] PART OF PATH ALONG SOREL ST, DIRECTLY BEHIND SE CB
BEING REMOVED.

CONCRETE DRAINAGE FLUME						L1
STATION	ALIGNMENT	LOCATION	LENGTH	WIDTH	AREA	DESCRIPTION
			LIN FT	LIN FT	SQ YD	
119+80.50	C/L - LT	45.5' - 52.0'	10	5	6	
PROJECT TOTAL					6	

CULVERT TABULATION																			L				
STATION		OFFSET				ALIGNMENT (FROM/TO)	INVERT UPSTREAM	INVERT DOWNSTREAM	FURNISH AND INSTALL														
									15" RCP CULVERT CL III	15" RC PIPE APRON	TRASH GUARD 15" PIPE APRON	24" RCP CULVERT CL III	24" RC PIPE APRON	TRASH GUARD 24" PIPE APRON	TRASH GUARD FOR 30" PIPE APRON	TRASH GUARD FOR 36" PIPE APRON	48" RCP CULVERT CL V	48" RCP APRON	RIPRAP CL II	RIPRAP CL III	GEOTEXTILE FILTER TYPE III	GEOTEXTILE FABRIC TYPE IV	SODDING TYPE SALT RESISTANT
STA.	STA.	LIN FT	RT	LT				LIN FT	EACH	EACH	LIN FT	EACH	EACH	EACH	EACH	LIN FT	EACH	CY	CY	SY	SY	SQ YD	
104+58.60	104+63.66	54	RT	55	LT	CL	901.82	901.19				98	2	2				6.2		29.7			13
107+39.88	107+95.01	26	RT	26	RT	CL	909.80	908.58	45	2	2												17
108+18.04	108+73.16	36	LT	36	LT	CL	909.84	909.38	43	2	2												17
110+38.57	110+93.69	33	LT	33	LT	CL	910.69	910.58	43	2	2												17
142+81.20	143+25.93	40	LT	40	LT	CL	908.34	908.20	33	2	2												17
SUBTOTAL									164	8	8	98	2	2	0	0	0	0	6	0	30	0	81
CITY OF CENTERVILLE / COUNTY DITCH																							
133+23.11		68	RT			CL									1								
133+98.03	133+99.05	1289	LT	1328	LT	CL										72	2			76		60	
139+44.37		66	RT			CL																	
SUBTOTAL									0	0	0	0	0	0	1	1	72	2	0	76	0	60	0
TOTAL									164	8	8	98	2	2	1	1	72	2	6	76	30	60	81

NOTES:

- OFFSETS ARE TO END OF APRON
- PIPE LENGTH DOES NOT INCLUDE APRON
- CITY OF CENTERVILLE / COUNTY DITCH CULVERT TO BE UNDER TRAIL IN CITY PARK

CONCRETE CURB, GUTTER, & WALK							O
STATION TO STATION	LOC.	CONCRETE CURB & GUTTER	CONCRETE CURB & GUTTER	4" CONCRETE WALK	PEDESTRIAN CURB RAMP	TRUNCATED DOMES	
		DES. B424 LIN FT	DES. B618 LIN FT				
				SQ FT	SQ FT	SQ FT	
120+25.21	137+60.69	RT CL	1,805				
120+32.69	130+36.55	LT CL	1,068				
131+02.38	144+26.91	LT CL	1,385				
137+91.36	144+30.74	RT CL	708				
144+59.56		RT CL	27				
144+60.99	149+99.51	RT CL	592				
144+68.10	152+21.28	LT CL	805				
150+23.68	152+24.62	RT CL	252				
152+47.58	152+93.94	RT CL	75				
152+50.10	155+70.86	LT CL	358				
155+57.73	155+76.87	RT CL		32			
155+97.51	156+20.53	RT CL		32			
156+01.63	156+19.50	LT CL		25			
120+31.63	120+44.23	LT - RT CL			104	62	24
126+53.35		LT -RT CL				103	24
137+46.77	138+02.46	RT CL				92	24
144+15.46		RT CL				52	12
144+16.46		LT CL				31	8
144+64.64	144+84.20	RT CL				67	20
144+64.98		RT CL			132		
144+68.01		LT CL			51	58	16
149+86.41	150+36.73	RT CL				94	24
152+14.34	152+63.06	RT CL			45	61	20
155+57.73	155+76.87	RT CL			130	40	12
155+97.51	156+20.53	RT CL			51	27	8
156+01.63	156+19.50	LT CL			39	27	8
PROJECT TOTAL			7,075	89	552	714	200

BITUMINOUS CURB REMOVAL AND CONSTRUCTION					Q
STATION TO STATION	ALIGNMENT	OFFSET	REMOVE	CONSTRUCT	
			LIN FT	LIN FT	
152+24.67 - 152+25.02	CSAH 21 CL	53'-45' RT	8	-	
152+47.69 - 152+47.85	CSAH 21 CL	57'-48' RT	9	-	
155+70.64 - 155+70.74	CSAH 21 CL	53'-40' LT	13	-	
155+76.80 - 155+76.87	CSAH 21 CL	58'-44' RT	14	14	
155+97.67 - 155+97.77	CSAH 21 CL	45'-36' RT	9	9	
156+01.67 - 156+01.79	CSAH 21 CL	33'-46' LT	13	13	
TOTAL			66	36	

MISCELLANEOUS REMOVALS							R
STATION	ALIGNMENT	OFFSET LIN FT	REMOVE		CONSTRUCT		
			DESCRIPTION	EACH	DESCRIPTION	SQ YD	
97+45.50	CL_21	38.8 RT	PRIVATE LIGHT (1)	1			
110+77.70	CL_21	36.8 LT	PRIVATE SIGN (1)	1			
119+76.70	CL_21	45.6 RT	PRIVATE SIGN (1)	1			
119+80.50	CL_21	43.9 LT	BIT FLUME	1			
TOTAL				4			0

NOTE:
(1) REMOVAL TO BE DONE BY OTHERS

TURF ESTABLISHMENT AND EROSION CONTROL															P									
STATION TO STATION	LOC.	SILT FENCE TYPE MACHINE SLICED	STORM DRAIN INLET PROTECTION	SEEDING SQ FT	SEEDING ACRE	SEED MIXTURE		SODDING TYPE SALT RESISTANT	MULCH MATERIAL TYPE 1	DISK ANCHORING	EROSION CONTROL BLANKET (CAT. 00)	EROSION CONTROL BLANKET (CAT. 4)	SEDIMENT CONTROL LOG TYPE - ROCK	FERTILIZER TYPE 3 22-5-10	FERTILIZER TYPE 4 18-1-8	RAPID STABILIZATION METHOD 3								
						310	250										TON	ACRE	SQ YD	SQ YD	LIN FT	POUND	POUND	M GAL
						POUND	POUND																	
93+42.37	107+65.50	RT	700	2	29863	0.7	35	19	437	1.0	0.5	1140		114	64	1.4								
93+53.98	108+35.84	LT	495	1	38266	0.9	56	13	2,611	1.4	0.7	1201		251	102	1.5								
107+73.47	119+90.37	RT	445	1	15576	0.4	13	14	607	0.4	0.2	860		108	23	1.1								
108+55.60	119+82.37	LT	559	3	8105	0.2	15		1,317	0.2	0.1	428		95	28	0.6								
120+31.85	130+36.55	LT	629	9	14029	0.3	22	3	625			1559		60	41	2.0								
120+25.21	130+28.97	RT	702	4	15293	0.4	10	17	323			1700		98	18	2.1								
130+48.82	144+30.74	RT	370	7	26168	0.6	33	13	1,458			2907		166	62	3.6								
131+02.42	144+26.91	LT	200	13	7992	0.2	15		2,055			888		149	28	1.1								
144+60.90	156+16.40	RT	205	15	7022	0.2	4	8	431			780		66	8	1.0								
144+61.82	156+15.42	LT	733	15	2930	0.1		4	829			296		81		0.4								
SUBTOTAL			5,040	70	165244	4	205	91	10694	3	2	11758		1188	372	15								
COUNTY DITCH																								
135+13.21		LT			7013	0.2	13			0.40	0.200		1800	110	30	1.2								
SUBTOTAL					7,013	0.2	13			0.4	0.2		1,800	110	30	1.2								
TOTAL			5,040	70	172,257	4	218	91	10,694	3	2	11,758		1,188	402	16								

NOTES:
- SEE SHEET 6 FOR 'BASIS OF QUANTITIES'.
- QUANTITIES ARE BASED ON 110% OF THE COMPUTED AREA.

NO	DATE	BY	CKD	APPR	REVISION

NAME: P:\02-621-10\Plan\2_SEQ.dgn 07/11/2014 1:36:41 PM

I HEREBY CERTIFY THAT THIS PLAN WAS PREPARED BY ME OR UNDER MY DIRECT SUPERVISION AND THAT I AM A DULY LICENSED PROFESSIONAL ENGINEER UNDER THE LAWS OF THE STATE OF MINNESOTA.
PRINT NAME: CURT A. KOBIARCSIK
SIGNATURE: *[Signature]*
DATE: 7-14-14 LICENSE NO. 24756

DRAWN BY: ZB DATE: 07-07-14
DESIGN BY: MN DATE: 07-07-14
CHECKED BY: CAK DATE: 07-11-14

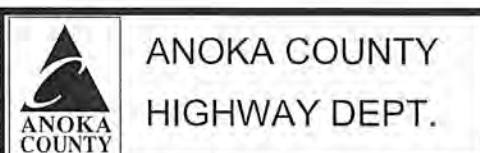

S.A.P. 002-621-010

UTILITY CONTACTS		AA
CITY OF CENTERVILLE 2085 WEST CEDAR STREET CENTERVILLE, MN 55038 CONTACT: PAUL PALZER TEL: 651-429-4750	GOPHER STATE ONE CALL FIELD UTILITY LOCATE REQUEST http://www.gopherstateonecall.org TEL 651-454-0002 OR TEL 1-800-252-1166	
CITY OF LINO LAKES 600 TOWN CENTER PKWY LINO LAKES, MN 55014 CONTACT: RICK DEGARDNER rick.degardner@ci.lino-lakes.mn.us TEL 651-982-2440	CENTERPOINT ENERGY 700 WEST LINDEN AVE P.O. BOX 1165 MINNAPOLIS, MN 55440-1165 CONTACT: ERIC YANG eric.yang@centerpointenergy.com TEL 612-321-5334	
CONNEXUS ENERGY 14601 RAMSEY BLVD RAMSEY, MN 55303 CONTACT: DOUG CABAK Doug.Cabak@connexusenergy.com TEL. 763-232-2710	CENTURYLINK 390 COMMERCE DR. WOODBURY, MN 55125 CONTACT: GAIL SHERRICK Gail.Sherrick@Centurylink.com TEL. 651-714-7540	
COMCAST CABLE 2611 FAIRVIEW AVE N ROSEVILLE, MN 55113 CONTACT: SCOTT RUPPERT Scott_Ruppert@cable.comcast.com TEL 651-755-2580	MET COUNCIL ENVIRONMENTAL SERVICES 3565 KENNEBAC DRIVE EAGAN, MN 55122 CONTACT: PETE OWENS pete.owens@metc.state.mn.us TEL. 651-755-1102	
ZAYO BANDWIDTH 400 CENTENNIAL PKWY SUITE 200 LOUISVILLE, CO 800027 CONTACT: FREDDIE KIGHT freddie.kight@zayo.com TEL 972-333-1320	XCEL ENERGY 1700 EAST COUNTY RD E WHITE BEAR LAKE, MN 55110 CONTACT: ZACHERY HUGHES zachery.t.hughes@xcelenergy.com TEL. 651-779-3139	

AGGREGATE BEDDING					T
STATION TO STATION	ALIGNMENT	OFFSET	LENGTH	DESCRIPTION	AGGREGATE BEDDING
		LIN FT	LIN FT		CU YD
104+58.60	LT - RT CL	66 - 24	110	4' W x 1' H	16
133+23.10	RT CL	68 - 24	45	4' W x 1' H	7
133+34.20	RT CL	24 - 30	193	4' W x 1' H	29
135+17.20	LT CL	60 - 19	42	5' W x 1.5' H	12
135+27.50	RT - LT CL	24 - 19	49	5' W x 1.5' H	14
135+27.50	RT CL	24 - 28	418	4' W x 1' H	62
135+27.60	LT CL	24	1660	5' W x 1.5' H	461
139+44.40	RT CL	66 - 28			
TOTAL					601

SUBSURFACE DRAINAGE						U
STATION TO STATION	LOCATION		4" PERF TP	FINE FILTER	DESCRIPTION	
	ALIGNMENT	OFFSET	PIPE DRAIN	AGGREGATE (LV)		
		LIN FT	LIN FT	CU YD		
120+44.20	122+30.00	LT CL	38 - 33	187	6	CG
122+30.00	123+12.00	LT CL	33	82	3	CG
123+12.00	124+26.20	LT CL	33 - 29	114	4	CG
124+26.20	126+02.00	LT CL	29	182	6	CG
126+02.00	127+30.00	LT CL	29 - 27	128	4	CG
127+30.00	130.05.20	LT CL	27 - 23	275	9	CG
131+37.70	132+99.80	LT CL	27	162	5	CG
132+99.80	135+27.60	LT CL	27 - 23	228	8	CG
135+27.60	137+01.20	LT CL	23	174	6	CG
137+01.20	139+08.50	LT CL	23 - 27	207	7	CG
139+08.50	141+36.80	LT CL	27 - 29	228	8	CG
141+36.80	143+65.00	LT CL	29	228	8	CG
143+65.00	143+96.90	LT CL	29	32	1	CG
145+01.80	146+17.90	LT CL	34	116	4	CG
146+17.90	147+49.20	LT CL	34	131	4	CG
147+49.20	149+65.90	LT CL	34 - 27	217	7	CG
149+65.90	151+11.40	LT CL	27 - 24	145	5	CG
151+11.40	151+87.40	LT CL	24	76	3	CG
152+87.10	154+14.00	LT CL	27	127	4	CG
154+14.00	155+40.80	LT CL	27	127	4	CG
120+40.70	123+12.00	RT CL	33 - 26	272	9	CG
123+12.00	126+02.00	RT CL	26 - 29	290	10	CG
126+02.00	127+30.00	RT CL	29 - 27	128	4	CG
127+30.00	132+99.80	RT CL	27 - 23	570	19	CG
132+99.80	135+27.40	RT CL	23 - 27	228	8	CG
135+27.40	137+01.20	RT CL	27	174	6	CG
137+01.20	137+30.80	RT CL	27	29	1	CG
138+21.90	139+08.00	RT CL	23 - 25	86	3	CG
139+08.00	141+36.80	RT CL	25 - 34	148	5	CG
141+36.80	142+25.00	RT CL	34	88	3	CG
142+25.00	143+65.00	RT CL	34	140	5	CG
143+65.00	144+00.80	RT CL	34	36	1	CG
144+91.00	146+17.90	RT CL	29	127	4	CG
146+17.90	148+00.00	RT CL	29 - 34	182	6	CG
148+00.00	149+65.90	RT CL	34 - 32	166	6	CG
150+53.10	151+11.40	RT CL	30	58	2	CG
151+11.40	151+87.40	RT CL	30 - 28	76	3	CG
TOTAL			5,964	201		

NOTE: SEE DRAINAGE PLAN (P.54-57) AND MISCELLANEOUS DETAILS (P.18) FOR MORE INFORMATION/LOCATION.

PROJECT CONTACTS			
DNR	NOT REQUIRED		
COE	NOT REQUIRED		
ANOKA COUNTY DESIGN SWPPP PREPRATION	U OF M DESIGN OF SWPPP EXPIRES 5/15	MARIO NAJI	763-862-4241
ANOKA COUNTY REPRESENTATIVE	U OF M SITE MANAGEMENT EXPIRES 5/15	BRUCE LUIKART	763-862-4242
EROSION CONTROL SUPERVISOR (CONTRACTOR)			

NO	DATE	BY	CKD	APPR	REVISION

NAME: P:\02-621-10\Plan\2_SEQ.dgn 07/11/2014 1:36:49 PM

I HEREBY CERTIFY THAT THIS PLAN WAS PREPARED BY ME OR UNDER MY DIRECT SUPERVISION AND THAT I AM A DULY LICENSED PROFESSIONAL ENGINEER UNDER THE LAWS OF THE STATE OF MINNESOTA.

PRINT NAME: CURT A. KOBILARCSIK
SIGNATURE: *Curt A. Kobilarsik*
DATE: 7-14-14 LICENSE NO. 24756

DRAWN BY: ZB DATE 07-07-14
DESIGN BY: MN DATE 07-07-14
CHECKED BY: CAK DATE 07-11-14

 ANOKA COUNTY HIGHWAY DEPT.

S.A.P. 002-621-010

TABULATIONS
Sheet 12 of 147 Sheets

CONNEXUS ENERGY					BB
STATION	OFFSET		INPLACE ITEM	REMARKS	
CSAH 21					
94+14	29	RT CL	POWER POLE		
94+22	30	RT CL	POWER POLE		
95+45	29	RT CL	POWER POLE		
96+85	30	RT CL	POWER POLE		
98+38	30	RT CL	POWER POLE		
100+12	29	RT CL	POWER POLE		
100+15	29	RT CL	POWER POLE		
103+08	29	RT CL	POWER POLE		
103+09	28	RT CL	POWER POLE		
105+69	29	RT CL	POWER POLE		
105+72	29	RT CL	POWER POLE		
108+48	29	RT CL	POWER POLE		
108+51	28	RT CL	POWER POLE		
109+16	27	LT CL	POWER POLE		
110+91	28	RT CL	POWER POLE		
111+39	29	RT CL	POWER POLE		
112+61	28	RT CL	POWER POLE		
112+65	28	RT CL	POWER POLE		
114+41	29	RT CL	POWER POLE		
114+42	28	RT CL	POWER POLE		
114+45	29	RT CL	POWER POLE		
114+89	27	LT CL	POWER POLE		
114+91	27	LT CL	POWER POLE		
116+87	31	RT CL	POWER POLE		
116+91	30	RT CL	POWER POLE		
119+46	31	RT CL	POWER POLE		
119+52	31	RT CL	POWER POLE		
119+52	26	RT CL	POWER POLE		
120+30	42	RT CL	POWER POLE		
120+30	41	RT CL	LIGHT POLE	REMOVE	
120+36	61	LT CL	LIGHT POLE		
120+54	33	RT CL	POWER POLE		
120+55	31	RT CL	POWER POLE		
122+11	32	RT CL	POWER POLE		
124+65	32	RT CL	POWER POLE		
124+68	32	RT CL	POWER POLE		
126+34	31	RT CL	POWER POLE		
126+38	31	RT CL	POWER POLE		
126+38	28	RT CL	POWER POLE		
126+40	27	LT CL	POWER POLE		
127+51	30	RT CL	POWER POLE		
127+54	30	RT CL	POWER POLE		
129+80	29	RT CL	POWER POLE		
129+83	28	RT CL	POWER POLE		
131+08	55	LT CL	LIGHT POLE		
131+28	29	RT CL	POWER POLE		

CONNEXUS ENERGY					BB
STATION	OFFSET		INPLACE ITEM	REMARKS	
CSAH 21					
131+31	28	RT CL	POWER POLE		
131+34	27	RT CL	POWER POLE		
133+51	27	RT CL	POWER POLE		
133+53	29	RT CL	POWER POLE		
133+55	29	RT CL	POWER POLE		
133+44	24	LT CL	POWER POLE		
136+56	29	RT CL	POWER POLE		
138+08	31	RT CL	POWER POLE		
138+08	28	RT CL	POWER POLE		
138+12	30	RT CL	POWER POLE		
139+44	29	RT CL	POWER POLE		
139+46	29	RT CL	POWER POLE		
139+59	28	RT CL	POWER POLE		
140+14	41	LT CL	LIGHT POLE		
140+48	40	LT CL	LIGHT POLE		
141+56	30	RT CL	POWER POLE		
141+59	29	RT CL	POWER POLE		
143+48	29	RT CL	POWER POLE		
143+51	29	RT CL	POWER POLE		
143+50	30	LT CL	POWER POLE		
143+80	30	LT CL	POWER POLE		
143+73	29	RT CL	POWER POLE		
143+75	29	RT CL	POWER POLE		
144+66	75	LT CL	LIGHT POLE		
145+61	28	RT CL	POWER POLE		
145+63	29	RT CL	POWER POLE		
147+16	28	RT CL	POWER POLE		
148+57	29	RT CL	POWER POLE		
150+36	29	RT CL	POWER POLE		
150+94	32	LT CL	POWER POLE		
152+12	29	RT CL	POWER POLE		
152+73	32	RT CL	POWER POLE		
155+65	34	LT CL	POWER POLE		
157+89	26	RT CL	POWER POLE		
158+25	27	RT CL	POWER POLE		
158+97	25	RT CL	SPLICE BOX		

COMCAST CABLE						CC
STATION		LOCATION		INPLACE ITEM	REMARKS	
BEGIN	END					
CSAH 21						
93+89		28	RT CL		SPLICE BOX	
93+89	93+90	28	RT CL 20 RT		BURIED	
93+90	94+56	20	RT CL 17 RT		BURIED	
94+56	96+57	17	RT CL 16 RT		BURIED	
96+57	97+02	16	RT CL 21 RT		BURIED	
97+02	97+83	21	RT CL 24 RT		BURIED	
97+83	100+11	24	RT CL 24 RT		BURIED	
100+11	100+87	24	RT CL 19 RT		BURIED	
100+87	105+05	19	RT CL 19 RT		BURIED	
105+05	107+77	19	RT CL 20 RT		BURIED	
107+77	108+20	20	RT CL 16 RT		BURIED	
108+20	110+20	16	RT CL 22 RT		BURIED	
110+20	112+38	22	RT CL 22 RT		BURIED	
112+38	113+29	22	RT CL 27 RT		BURIED	
113+29	114+35	27	RT CL 25 RT		BURIED	
114+35		25	RT CL		SPLICE BOX	
114+35	114+90	25	RT CL 29 LT		BURIED	
114+90	114+90	29	LT CL 65 LT		BURIED	
114+35	119+58	25	RT CL 19 RT		BURIED	
119+58	120+40	19	RT CL 23 RT		BURIED	
120+40	122+11	23	RT CL 22 RT		BURIED	
122+11		32	RT CL		SPLICE BOX	
122+11	126+25	22	RT CL 20 RT		BURIED	
126+25	130+61	20	RT CL 21 RT		BURIED	
130+61		26	RT CL		SPLICE BOX	
130+61	133+01	26	RT CL 23 RT		BURIED	
133+01	134+37	23	RT CL 19 RT		BURIED	
134+37	138+03	19	RT CL 24 RT		BURIED	
138+03	138+12	24	RT CL 28 RT		BURIED	
138+12		29	RT CL		SPLICE BOX	
138+12	144+84	28	RT CL 32 RT		BURIED	
144+84	145+49	32	RT CL 30 RT		BURIED	
145+49	147+98	30	RT CL 31 RT		BURIED	
147+98	148+85	31	RT CL 31 RT		BURIED	
148+85	150+40	31	RT CL 27 RT		BURIED	
150+40		30	RT CL		SPLICE BOX	
150+40	151+52	27	RT CL 23 RT		BURIED	
151+52	152+09	23	RT CL 27 RT		BURIED	
152+09	152+50	27	RT CL 29 RT		BURIED	
152+50	155+64	29	RT CL 30 RT		BURIED	
155+64		30	RT CL		SPLICE BOX	

I HEREBY CERTIFY THAT THIS PLAN WAS PREPARED BY ME OR UNDER MY DIRECT SUPERVISION AND THAT I AM A DULY LICENSED PROFESSIONAL ENGINEER UNDER THE LAWS OF THE STATE OF MINNESOTA. PRINT NAME: CURT A. KOBILARCSIK SIGNATURE: <i>Curt Kobilarsik</i> DATE: 7-14-14 LICENSE NO. 24756					DRAWN BY: ZB DATE: 07-07-14 DESIGN BY: MN DATE: 07-07-14 CHECKED BY: CAK DATE: 07-11-14		ANOKA COUNTY HIGHWAY DEPT.		S.A.P. 002-621-010		TABULATIONS Sheet 13 of 147 Sheets	
NO	DATE	BY	CKD	APPR	REVISION				NAME: P:\02-621-10\Plan2_SEQ.dgn 07/11/2014 1:36:56 PM			

CENTERPOINT ENERGY - GAS							DD
STATION		LOCATION	INPLACE ITEM				REMARKS
BEGIN	END						
CSAH 21							
93+57	93+73	57 LT CL 29 LT	4" PE				
93+73	94+08	29 LT CL 22 LT	4" PE				
94+08		22 LT CL	VALVE				
94+08	94+13	22 LT CL 112 RT					
94+08	97+47	22 LT CL 20 LT	4" ST				
97+47	97+45	20 LT CL 107 RT					
97+47	97+84	20 LT CL 20 LT	4" ST				
97+84	97+84	20 LT CL 80 RT					
97+84	101+18	20 LT CL 21 LT	4" ST				
101+18	101+19	21 LT CL 114 LT					
101+18	108+30	21 LT CL 24 LT	4" ST				
108+30	108+30	24 LT CL 118 LT					
108+30	109+15	24 LT CL 28 LT	4" ST				
109+15	109+15	28 LT CL 69 RT					
109+15	110+27	28 LT CL 24 LT	4" ST				
110+27	110+27	24 LT CL 115 LT					
110+27	113+34	24 LT CL 24 LT	4" ST				
113+34	113+34	24 LT CL 82 RT					
113+34	114+50	24 LT CL 24 LT	4" ST				
114+50	114+50	24 LT CL 75 LT					
114+50	115+50	24 LT CL 21 LT	4" ST				
115+50	115+50	21 LT CL 200 RT					
115+50	119+73	21 LT CL 21 LT	4" ST				
119+73	119+73	21 LT CL 19 RT					
119+73	119+84	19 RT CL 31 RT					
119+84	119+84	31 RT CL 43 RT					
119+84	120+46	21 LT CL 21 LT	4" ST				
120+46		21 LT CL	VALVE				
120+46	120+29	21 LT CL 143 LT	2" TR				
120+46	120+46	21 LT CL 110 RT	2" TR				
120+46	123+78	21 LT CL 21 LT	4" ST				
123+78	123+78	21 LT CL 108 LT					
123+78	125+00	21 LT CL 21 LT	4" ST				
125+00	125+00	21 LT CL 100 LT					
125+00	126+35	21 LT CL 23 LT	4" ST				
126+35		23 LT CL	VALVE				
126+35	126+77	23 LT CL 23 LT	4" ST				
126+77		23 LT CL	VALVE				
126+77	131+34	23 LT CL 21 LT	4" ST				
131+34		21 LT CL	VALVE				
131+34	131+34	21 LT CL 50 LT	2" TR				
131+34	131+12	50 LT CL 50 LT	2" TR				
131+12	131+06	50 LT CL 112 LT	2" TR				
131+34	135+85	21 LT CL 19 LT	4" ST				
135+85	135+85	19 LT CL 100 LT					
135+85	137+86	19 LT CL 19 LT	4" ST				
137+86	137+86	19 LT CL 107 LT					

CENTERPOINT ENERGY - GAS							DD
STATION		LOCATION	INPLACE ITEM				REMARKS
BEGIN	END						
CSAH 21							
137+86	138+11	19 LT CL 18 LT	4" ST				
138+11	138+11	18 LT CL 16 RT	2" PE				
138+11	137+96	16 RT CL 42 RT	2" PE				
138+11	138+55	18 LT CL 18 LT	4" ST				
138+55	138+55	18 LT CL 107 LT					
138+55	139+62	18 LT CL 19 LT	4" ST				
139+62	139+62	19 LT CL 115 LT					
139+62	140+99	19 LT CL 19 LT	4" ST				
140+99	140+99	19 LT CL 114 LT					
140+99	142+83	19 LT CL 20 LT	4" ST				
142+83	142+83	20 LT CL 94 LT					
142+83	143+52	20 LT CL 20 LT	4" ST				
143+52		20 LT CL	VALVE				
143+52	144+11	20 LT CL 18 LT	4" ST				
144+11	144+22	18 LT CL 198 LT					
144+11	145+33	18 LT CL 20 LT	4" ST				
145+33	145+33	20 LT CL 97 RT					
145+33	146+76	20 LT CL 18 LT	4" ST				
146+76	146+76	18 LT CL 85 RT					
146+76	147+97	18 LT CL 15 LT	4" ST				
147+97	147+81	15 LT CL 78 RT					
147+97	150+60	15 LT CL 21 LT	4" ST				
150+60	150+60	21 LT CL 96 LT					
150+60	152+62	21 LT CL 22 LT	4" ST				
152+62		22 LT CL	VALVE				
152+62	152+58	22 LT CL 64 LT					
152+62	153+33	22 LT CL 21 LT	4" ST				
153+33	153+33	21 LT CL 105 RT					
153+33	155+65	21 LT CL 24 LT	4" ST				
155+65		24 LT CL	VALVE				
155+65	155+71	24 LT CL 69 LT	4" ST				
155+65	155+65	24 LT CL 102 RT	4" TR				
155+65	156+41	24 LT CL 24 LT	2" ST				
156+41	156+41	24 LT CL 51 RT					
156+41	157+31	24 LT CL 24 LT	2" ST				
157+31	157+31	24 LT CL 37 RT					
157+31	157+45	24 LT CL 24 LT	2" ST				
157+45	157+45	24 LT CL 42 LT					
157+45	157+92	24 LT CL 24 LT	2" ST				
157+92	157+92	24 LT CL 43 LT					
157+92	158+56	24 LT CL 24 LT	2" ST				
158+56		24 LT CL	VALVE				

NO	DATE	BY	CKD	APPR	REVISION
NAME: P:\02-621-10\Plan2_SEQ.dgn 07/11/2014 1:37:04 PM					

I HEREBY CERTIFY THAT THIS PLAN WAS PREPARED BY ME OR UNDER MY DIRECT SUPERVISION AND THAT I AM A DULY LICENSED PROFESSIONAL ENGINEER UNDER THE LAWS OF THE STATE OF MINNESOTA.
 PRINT NAME: CURT A. KOBILARCSIK
 SIGNATURE: *Curt Kobilarsik*
 DATE: 7-14-14 LICENSE NO. 24756

DRAWN BY: ZB DATE: 07-07-14
 DESIGN BY: MN DATE: 07-07-14
 CHECKED BY: CAK DATE: 07-11-14



ANOKA COUNTY
 HIGHWAY DEPT.

S.A.P. 002-621-010

TABULATIONS
 Sheet 14 of 147 Sheets

CITY OF CENTERVILLE							EE		
STATION	LOCATION			INPLACE ITEM	ADJUST GATE VALVE	RELOCATE HYDRANT & VALVE	RELOCATE HYDRANT	ADJUST SANITARY MANHOLE	REMARKS
					EACH	EACH	EACH	EACH	
120+15	54	LT	CL	GV	1				
120+17	65	RT	CL	GV	1				
120+32	54	LT	CL	GV	1				
124+21	38	RT	CL	SAN MH				1	ADJUST (1)
125+19	39	LT	CL	HYD					LEAVE
125+19	37	LT	CL	GV	1				
125+48	38	LT	CL	GV	1				
127+06	44	RT	CL	SAN MH				1	ADJUST (1)
130+74	32	RT	CL	SAN MH				1	ADJUST (1)
130+77	57	LT	CL	GV	1				
130+78	41	RT	CL	GV	1				
132+52	74	LT	CL	SAN MH					LEAVE (1)
132+60	24	RT	CL	GV					LEAVE (1)
132+62	24	RT	CL	HYD					LEAVE (1)
132+69	38	RT	CL	SAN MH				1	ADJUST (1)
132+89	66	RT	CL	GV					LEAVE
133+69	44	LT	CL	GV					LEAVE
134+82	44	RT	CL	SAN MH				1	ADJUST (1)
137+35	58	RT	CL	GV					LEAVE
137+48	70	RT	CL	HYD					LEAVE
137+50	70	RT	CL	GV					LEAVE
137+69	64	RT	CL	GV	1				
137+78	28	RT	CL	SAN MH				1	ADJUST (1)
140+38	38	RT	CL	HYD		1			
140+72	41	RT	CL	GV	1				
140+74	44	RT	CL	GV	1				
141+61	59	LT	CL	GV					LEAVE
141+78	59	LT	CL	GV					LEAVE
141+80	33	RT	CL	SAN MH				1	ADJUST (1)
142+08	53	LT	CL	GV					LEAVE
142+87	24	RT	CL	SAN MH				1	ADJUST (1)
143+00	53	RT	CL	SAN MH				1	ADJUST (1)
144+48	32	RT	CL	SAN MH				1	ADJUST (1)
144+50	30	LT	CL	SAN MH				1	ADJUST (1)
144+53	39	RT	CL	GV	1				
144+58	50	RT	CL	GV	1				
144+63	53	RT	CL	GV	1				
144+65	53	RT	CL	HYD					LEAVE
148+17	31	LT	CL	SAN MH				1	ADJUST (1)
149+21	28	RT	CL	GV	1				
149+24	40	LT	CL	GV					LEAVE
149+82	33	LT	CL	GV/WSO	1				
150+24	40	RT	CL	GV	1				
150+26	42	RT	CL	GV	1				
150+28	42	RT	CL	HYD		1			
151+62	28	LT	CL	SAN MH				1	ADJUST (1)
152+37	1	RT	CL	SAN MH				1	ADJUST (1)
152+43	26	RT	CL	GV	1				
152+47	30	RT	CL	GV	1				
152+51	27	RT	CL	GV	1				
152+57	38	LT	CL	HYD			1		HYD ONLY
155+85		LT	CL	SAN MH					LEAVE
PROJECT TOTAL					20	2	1	14	

NOTES:

- (1) SEE TAB H ON SHEET 13 FOR SANITARY MANHOLE ADJUSTMENTS.
- SEE CITY OF CENTERVILLE WATERMAIN PLAN AND TABULATIONS ON SHEETS 155-157 FOR MORE INFORMATION.
- UTILITY COMPANIES SHALL COORDINATE WITH CITY OF CENTERVILLE FOR STREET LIGHT LOCATIONS ALONG CSAH 21

CENTURYLINK- TELEPHONE				FF
STATION	OFFSET		INPLACE ITEM	REMARKS
	BEGIN	END		
CSAH 21				
	LINE 1	LINE 2		
93+66	32 LT CL		MANHOLE	
93+66 93+91	32 LT CL 36 LT		BURIED	
93+91	36 LT CL		SPLICE BOX	
93+91 93+89	36 LT CL 28 RT		BURIED	
93+89	28 RT CL		SPLICE BOX	
93+91 100+49	16 LT CL 15 LT	36 LT CL 28 LT	BURIED	
100+49	25 LT CL		SPLICE BOX	
100+49 105+70	25 LT CL 14 LT	28 LT CL 16 LT	BURIED	
105+70 108+58	14 LT CL 15 LT	16 LT CL 22 LT	BURIED	
108+58 114+90	15 LT CL 14 LT	22 LT CL 19 LT	BURIED	
114+90	26 LT CL		SPLICE BOX	
114+90 118+34	14 LT CL 12 LT	19 LT CL 16 LT	BURIED	
118+34 119+30	12 LT CL 14 LT	16 LT CL 22 LT	BURIED	
119+30	28 LT CL		SPLICE BOX	
119+30 120+58	14 LT CL 13 LT	22 LT CL 19 LT	BURIED	
120+58	25 LT CL		SPLICE BOX	
120+58 120+47	25 LT CL 37 RT		BURIED	
120+47	37 RT CL		SPLICE BOX	
120+58 122+77	13 LT CL 16 LT	19 LT CL 17 LT	BURIED	
122+77	41 LT CL		SPLICE BOX	
122+77 120+48	41 LT CL 52 LT		BURIED	
122+77 126+41	16 LT CL 13 LT	17 LT CL 17 LT	BURIED	
126+41	27 LT CL		SPLICE BOX	
126+41 130+07	13 LT CL 13 LT	17 LT CL 16 LT	BURIED	
130+07	17 LT CL		SPLICE BOX	
130+07 130+23	17 LT CL 53 LT		BURIED	
130+07 133+44	13 LT CL 13 LT	16 LT CL 17 LT	BURIED	
133+44	23 LT CL		SPLICE BOX	
133+44 135+37	13 LT CL 13 LT	17 LT CL 16 LT	BURIED	
135+37 135+44	14 LT CL 14 LT	16 LT CL 19 LT	BURIED	
135+44 138+26	15 LT CL 13 LT	19 LT CL 22 LT	BURIED	
138+27	21 LT CL		SPLICE BOX	
138+27 138+06	21 LT CL 81 RT		BURIED	
138+06	81 RT CL		SPLICE BOX	
138+06 137+48	81 RT CL 80 RT		BURIED	
137+48	80 RT CL		SPLICE BOX	
138+27 138+31	21 LT CL 16 LT	21 LT CL 30 LT	BURIED	
138+31 140+48	16 LT CL 13 LT	30 LT CL 30 LT	BURIED	

CENTURYLINK- TELEPHONE				FF
STATION	OFFSET		INPLACE ITEM	REMARKS
	BEGIN	END		
CSAH 21				
	LINE 1	LINE 2		
140+49	32 LT CL		SPLICE BOX	
140+49 143+54	13 LT CL 12 LT	30 LT CL 21 LT	BURIED	
143+54	20 LT CL		SPLICE BOX	
143+54 146+40	12 LT CL 13 LT	21 LT CL 21 LT	BURIED	
146+40 147+68	13 LT CL 14 LT	21 LT CL 19 LT	BURIED	
147+68 150+32	14 LT CL 15 LT	19 LT CL 21 LT	BURIED	
150+32 150+82	15 LT CL 14 LT	21 LT CL 27 LT	BURIED	
150+82 151+23	14 LT CL 15 LT	27 LT CL 26 LT	BURIED	
151+23		26 LT CL	SPLICE BOX	
151+23 151+21		26 LT CL 25 RT	BURIED	
151+21 150+40		25 RT CL 30 RT	BURIED	
150+40		30 RT CL	SPLICE BOX	
151+23 151+27		26 LT CL 25 RT	BURIED	
151+27 152+15		25 RT CL 30 RT	BURIED	
151+23 151+28	15 LT CL 15 LT	26 LT CL 17 LT	BURIED	
151+28 151+98	15 LT CL 12 LT	17 LT CL 18 LT	BURIED	
151+98 152+02	12 LT CL 8 LT	18 LT CL 38 LT	BURIED	
152+02 152+20	8 LT CL 0 LT		BURIED	
152+20 152+21	0 LT CL 27 RT		BURIED	
152+21 155+64	27 RT CL 30 RT		BURIED	
155+64	30 RT CL		SPLICE BOX	
155+64 156+02	30 RT CL 34 RT		BURIED	
156+02 156+08	34 RT CL 41 LT		BURIED	

ZAYO BANDWIDTH				GG
STATION	LOCATION	INPLACE ITEM	REMARKS	
				BEGIN
CSAH 21				
92+78	34 LT CL	SPLICE BOX		
92+78 92+79	34 LT CL 14 RT	FIBER		
92+79 96+57	14 RT CL 9 RT	FIBER		
96+57 97+02	9 RT CL 15 RT	FIBER		
97+02 97+63	15 RT CL 17 RT	FIBER		
97+63 102+87	17 RT CL 16 RT	FIBER		
102+87 108+34	16 RT CL 14 RT	FIBER		
108+34 114+59	14 RT CL 15 RT	FIBER		
114+59 120+84	15 RT CL 14 RT	FIBER		
120+84 126+68	14 RT CL 14 RT	FIBER		
126+68 132+25	14 RT CL 15 RT	FIBER		
132+25 138+10	15 RT CL 16 RT	FIBER		
138+10 138+53	16 RT CL 14 RT	FIBER		
138+53 143+95	14 RT CL 14 RT	FIBER		
143+95 149+25	14 RT CL 14 RT	FIBER		
149+25 152+62	14 RT CL 22 RT	FIBER		
152+62 155+64	22 RT CL 30 RT	FIBER		

NO	DATE	BY	CKD	APPR	REVISION
NAME: P:\02-621-10\Plan2_SEQ.dgn 07/11/2014 1:37:09 PM					

I HEREBY CERTIFY THAT THIS PLAN WAS PREPARED BY ME OR UNDER MY DIRECT SUPERVISION AND THAT I AM A DULY LICENSED PROFESSIONAL ENGINEER UNDER THE LAWS OF THE STATE OF MINNESOTA.
 PRINT NAME: CURT A. KOBLARCSIK
 SIGNATURE: *Curt Koblarcsik*
 DATE: 7-14-14 LICENSE NO. 24756

DRAWN BY: ZB DATE: 07-07-14
 DESIGN BY: MN DATE: 07-07-14
 CHECKED BY: CAK DATE: 07-11-14



ANOKA COUNTY
 HIGHWAY DEPT.

S.A.P. 002-621-010

TABULATIONS
 Sheet 15 of 147 Sheets

EARTHWORK BALANCE Sta 93+40 to 155+68 Reconstruction CSAH 21				V
EXCAVATION (LV) (CU YD)		EMBANKMENT (CV) (CU YD)		(+) EXCESS / (-) BORROW (LV) (CU YD)
COMMON EXCAVATION	SUITABLE (EV) 13,578 18,412 (EV) (Pay Item)	10,445 (CV) Shrink 1.30%	SUITABLE GRADING 11,713 (CV)	SUITABLE GRADING (1) (LV) [EXC(Suitable+Subcut)-EMB(Suitable+Subcut)]xSwell = 7,920 (+) = Excess (-) = BORROW EXCESS Swell Factor 1.35% [(10,445+7,135)-(11,713+ 0.00)]x1.35%= 7,920
SUBGRADE EXCAVATION (2)	TOPSOIL (EV) 4,834 (Pay Item)	3,718 (CV) Shrink 1.30%	TOPSOIL 2,776 (CV)	TOPSOIL (LV) [EXC.Topsoil - EMB.Topsoil]x Swell Factor] = 1,272 (+) = Excess (-) = BORROW EXCESS Swell Factor 1.35% (EXC 7,135 - EMB 10,077) X 1.35% = 1,272
MUCK EXCAVATION	SUBCUT (EV) 9,276 (Pay Item)	7,135 (CV) Shrink 1.30%	SUBGRADE BACKFILL 10,077 (CV)	SELECT GRANULAR (LV) [EXC(Subgrade)-EMB(Sabgrade)] xSwell Factor= -13,604 PAY ITEM (+) = Excess (-) = BORROW Swell Factor [(+ 0.00) - (+ 10,077)] x 1.35%= (13,604)
	MUCK (EV) 356 (Pay Item)	274 (CV) Shrink 1.30%	MUCK BACKFILL 274 (CV)	MUCK BACKFILL (LV) [(EMB. Muck Backfill)x Swell Factor] = 356 PAY ITEM (EMB 274) X 1.30% = 356 Swell Factor 1.30%
		(EV to CV) Shrinkage Factor		(CV to LV) Swell Factor

NOTE:

- (1)- SUITABLE GRADING EXCESS, INCLUDE SUBGRADE EXCAVATION MATERIAL.
- (2)- SUBGRADE CUT EXCAVATION MATERIAL REMOVED & REPLACE WITH SELECT GRANULAR (STATIONS 142+50 TO 146+80 AND 151+00 TO 152+30, 3' SUBCUT/SELECT GRANULAR FILL)

GENERAL NOTES:

- A - TO THE EXTENT POSSIBLE OR AT THE DIRECTION OF THE ENGINEER, WHERE THE ENGINEER DEEMS THE SUITABLE MATERIAL ACCEPTABLE, THE CONTRACTOR SHALL BE REQUIRED TO USE THE ON SITE EXCAVATED MATERIAL TO OFFSET THE SHORTAGE OF SELECT GRANULAR MATERIAL WITH NO ADDITIONAL COMPENSATION.
- B - SEE SOILS AND CONSTRUCTION NOTES FOR MATERIAL DEFINITIONS AND ADDITIONAL INFORMATION. ALL MATERIAL NOT USED ON THE PROJECT SHALL BECOME THE PROPERTY OF THE CONTRACTOR AND SHALL BE REMOVED FROM THE PROJECT LIMITS WITH NO DIRECT PAYMENT THEREFORE. THE MATERIAL QUANTITY IS BASED ON ESTIMATED QUANTITIES. DISPOSAL SHALL BE IN ACCORDANCE WITH SPEC. 2105. THE CONTRACTOR SHALL OBTAIN APPROVAL FROM THE ENGINEER BEFORE HAULING ANY MATERIAL OFF SITE.

SOIL & CONSTRUCTION NOTES

- SUITABLE GRADING MATERIAL ON THIS PROJECT SHALL CONSIST OF ALL SOILS ENCOUNTERED WITH THE EXCEPTION OF SLOPE DRESSING, DEBRIS, ORGANIC MATERIAL, MUCK AND OTHER UNSUITABLE MATERIAL.
- ITEMS REFERRED TO AS INCIDENTAL ON THIS PROJECT SHALL BE CONSIDERED INCIDENTAL WITH NO DIRECT COMPENSATION MADE THEREFORE.
- SELECT GRANULAR MATERIAL SHALL MEET THE REQUIREMENTS OF SPEC. 3149.2B2, OR AS DIRECTED BY THE ENGINEER.
- BITUMINOUS AND CONCRETE ITEMS REMOVED BY CONSTRUCTION SHALL BECOME THE PROPERTY OF THE CONTRACTOR AND SHALL EITHER BE RECYCLED OR DISPOSED OF OFF THE PROJECT, IN ACCORDANCE WITH THE PROVISIONS OF SPEC. 2104.3C3 WITH NO DIRECT COMPENSATION MADE THEREFORE.
- COMPACTION OF THE GRADING ITEMS OF THIS PROJECT, BOTH PERMANENT AND TEMPORARY, SHALL BE BY THE "SPECIFIED DENSITY METHOD", EXCEPT WHEN WITHIN 3 FEET OF THE WATER TABLE, THEN BY THE "QUALITY COMPACTION METHOD" OR AS DIRECTED BY THE ENGINEER.
- COMPACTION OF THE AGGREGATE BASE ITEMS OF THIS PROJECT, BOTH PERMANENT AND TEMPORARY, SHALL BE BY THE "SPECIFIED DENSITY METHOD" EXCEPT WHEN THE CONTRACTOR ELECTS TO USE RECYCLED MATERIALS FOR THE AGGREGATE BASE ITEMS, THEN THE "QUALITY COMPACTION METHOD" SHALL BE UTILIZED.
- WHERE WIDENING ADJACENT TO EXISTING PAVEMENT, CUT VERTICALLY TO THE BOTTOM OF THE CLASS 5 AGGREGATE BASE AND THEN AT A 1V:1/2H SLOPE TO THE BOTTOM OF THE BOTTOM OF THE RECOMMENDED SUBGRADE EXCAVATION (AS SHOWN ON THE TYPICAL SECTIONS AND THE CROSS SECTIONS). BACKFILL PROMPTLY TO AVOID UNDERMINING THE EXISTING PAVEMENT.
- PROVIDE 1:20 LONGITUDINAL TAPERS BETWEEN CHANGES IN SUBGRADE AND SUBCUT DEPTHS.
- USE TACK COAT BETWEEN ALL BITUMINOUS MIXTURES AND WHERE CONCRETE CURBING ABUTS BITUMINOUS MIXTURES. THE BITUMINOUS TACK COAT MATERIAL SHALL BE APPLIED AT A UNIFORM RATE OF 0.05 GAL./SQ. YD. BETWEEN BITUMINOUS LAYERS. APPLICATION RATES ARE APPLICABLE FOR UNDILUTED EMULSIONS (AS SUPPLIED FROM THE REFINERY). ASPHALT EMULSIONS MAY BE FURTHER DILUTED IN THE FIELD IN ACCORDANCE WITH SPEC. 2357.
- STRIP AND REUSE AS SLOPE DRESSING ALL EXISTING TOPSOIL, WHERE PRESENT, IN AREAS TO BE DISTURBED BY CONSTRUCTION. APPROXIMATE DIMENSIONS ENCOUNTERED ARE ASSUMED TO BE 0 INCHES TO 24 INCHES, AND AVERAGE IS 3 INCHES. (CONTRACTOR TO VERIFY PRIOR TO PLACING BID) NO WARRANTY MADE ON THIS INFORMATION.
- PLACE A MINIMUM OF 4 INCHES OF SLOPE DRESSING ON ALL AREAS SCHEDULED FOR PERMANENT TURF ESTABLISHMENT. ALL EXCESS TOPSOIL SHALL BECOME THE PROPERTY OF THE CONTRACTOR AND SHALL BE DISPOSED OF OUTSIDE THE RIGHT-OF-WAY.
- DITCH GRADE ELEVATIONS ON THE CROSS SECTIONS AND PROFILE DRAWINGS ARE AT THE BOTTOM OF TOPSOIL. ON ALL DRAWINGS WITH CONTOURS, THE ELEVATIONS ARE AT THE TOP OF TOPSOIL.
- DITCH BOTTOMS, TOE OF FILL, CUT RUNOUTS, AND THE TOP EDGE OF THE BACKSLOPES SHALL BE ROUNDED REGARDLESS OF THE SECTION USED ON THE CROSS SECTION SHEETS.
- SOIL BORINGS ALONG THE PROJECT INDICATE THE EXISTING CSAH 57 AND CSAH 116 BITUMINOUS PAVEMENT AVERAGES 6 INCHES THICK. FOR INFORMATION ONLY. NO WARRANTY ON THIS INFORMATION. CONTRACTOR SHALL VERIFY PRIOR TO PLACING BID.
- ALL SILT FENCING AS SHOWN IN THE PLANS SHALL BE IN PLACE PRIOR TO THE COMMENCEMENT OF GRADING OPERATIONS.
- EXPECT WET CONDITIONS IN MUCK EXCAVATION AND POND EXCAVATION AREAS. CLEAN CRUSHED ROCK WILL LIKELY BE NECESSARY TO STABILIZE THE BOTTOM OF THE MUCK EXCAVATION FOR PLACEMENT OF FILL. DEWATERING WITH SUMP PUMPS CAN ALSO BE EXPECTED. THIS IS INCIDENTAL TO MUCK EXCAVATION AND BACKFILL, AND POND EXCAVATION.

NO	DATE	BY	CKD	APPR	REVISION

NAME: P:\02-621-10\Plan\0262110_EW.dgn 07/11/2014 2:13:13 PM

I HEREBY CERTIFY THAT THIS PLAN WAS PREPARED BY ME OR UNDER MY DIRECT SUPERVISION AND THAT I AM A DULY LICENSED PROFESSIONAL ENGINEER UNDER THE LAWS OF THE STATE OF MINNESOTA.
 PRINT NAME: CURT A. KOBILARCSIK
 SIGNATURE: *Curt Kobilarsik*
 DATE: 7-14-14 LICENSE NO. 24756

DRAWN BY: ZB DATE 07-07-14
 DESIGN BY: MN DATE 07-07-14
 CHECKED BY: CAK DATE 07-11-14



ANOKA COUNTY
HIGHWAY DEPT.

S.A.P. 002-621-010

EARTHWORK TABULATION

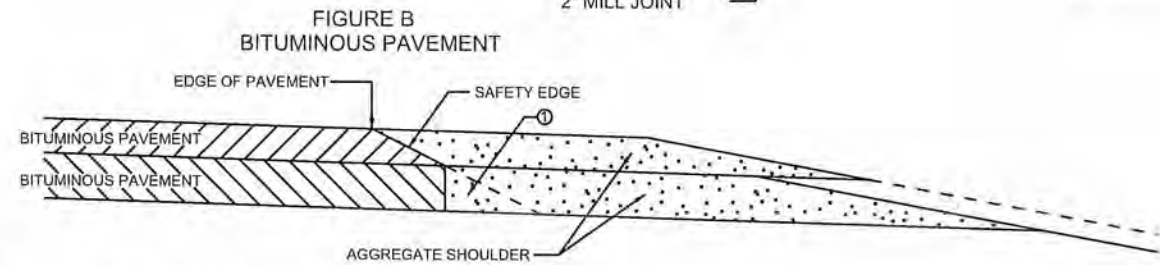
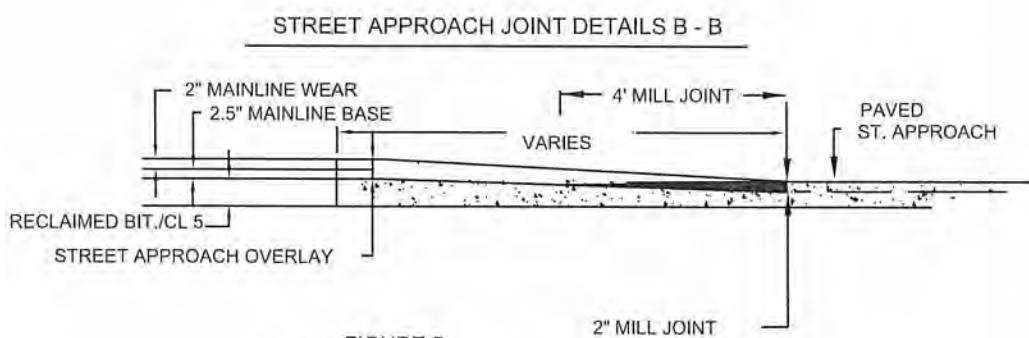
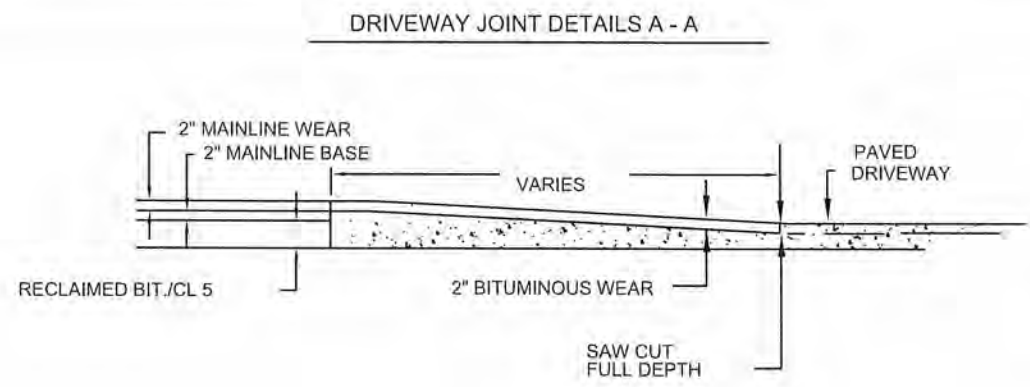
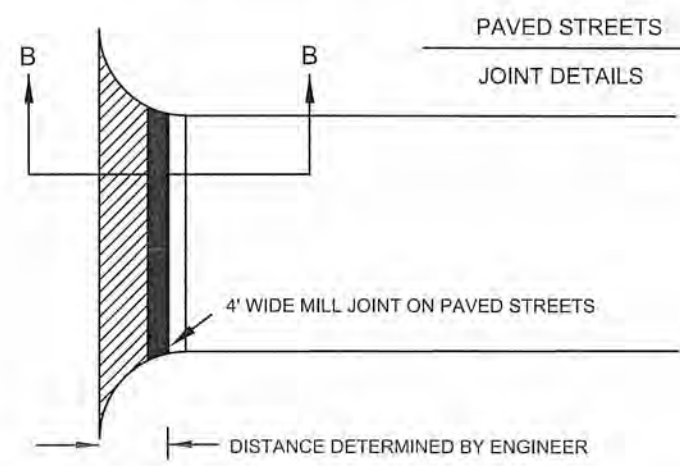
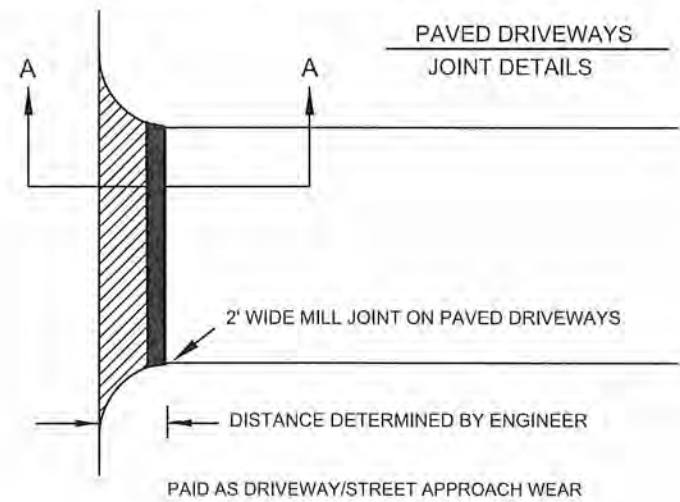

① OPTIONAL DESIGN EXTENDS SAFETY EDGE DEEPER THAN 6" AND WIDER THAN 10.5". SEE SPECAL PROVISIONS FOR DETAILS.

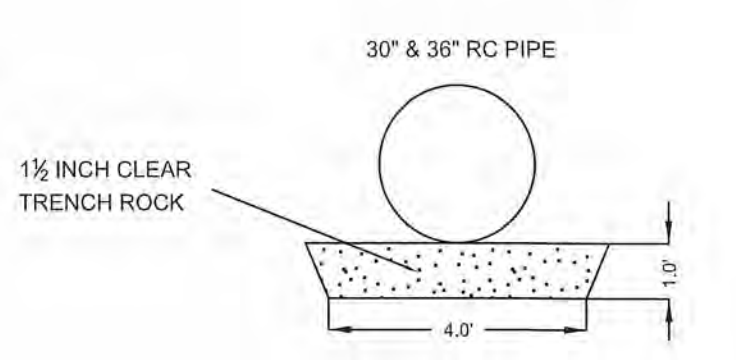
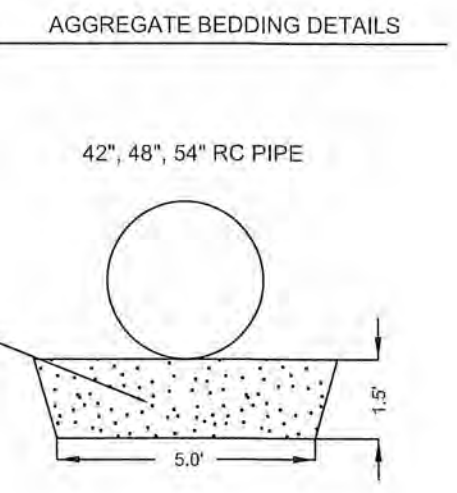

OVERLAY EXISTING STREET APPROACH, DO NOT RECLAIM STREETS TO BE PAVED IN SEPERATE OPERATION OTHER THAN MAINLINE WEAR. PAID AS DRIVEWAY/STREET APPROACH WEAR.

SUBSURFACE DRAIN DETAIL

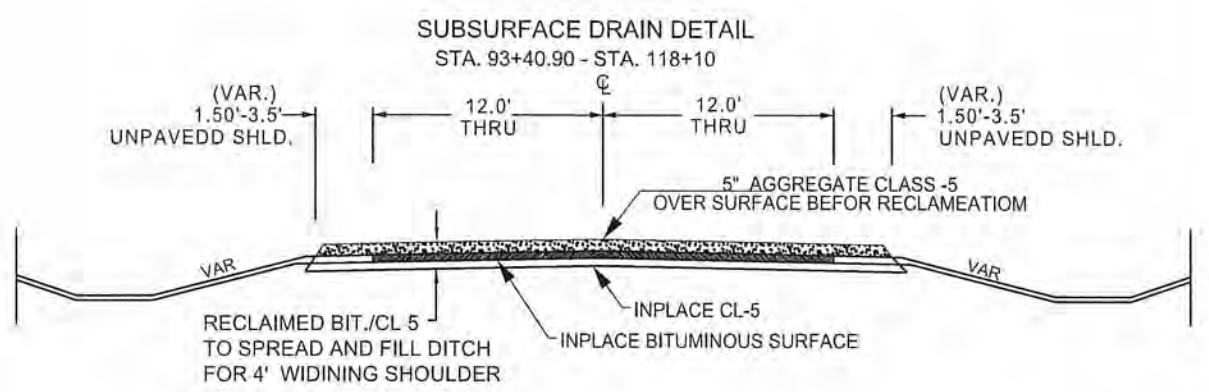

- NOTES:
1. SEE SHEET 12, TAB U FOR MORE INFORMATION
 2. SEE DRAINAGE PLANS FOR LOCATIONS

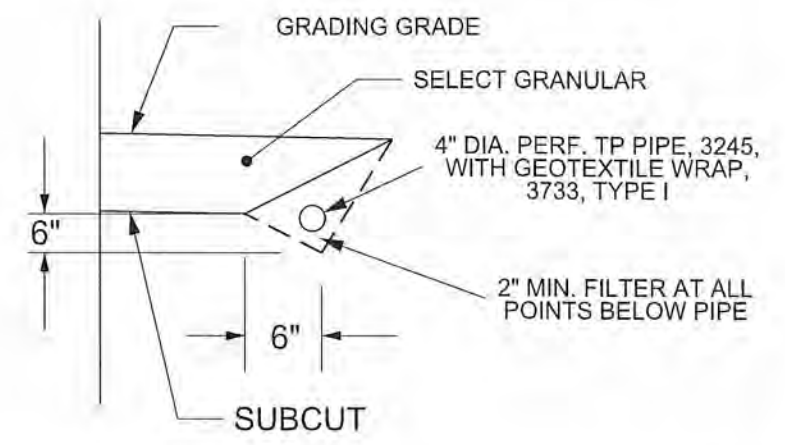

NO	DATE	BY	CKD	APPR	REVISION

NAME: P:\02-621-10\Plan\6_Typical-1.dgn 07/11/2014 1:37:37 PM

I HEREBY CERTIFY THAT THIS PLAN WAS PREPARED BY ME OR UNDER MY DIRECT SUPERVISION AND THAT I AM A DULY LICENSED PROFESSIONAL ENGINEER UNDER THE LAWS OF THE STATE OF MINNESOTA.

PRINT NAME: CURT A. KOBILARCSIK
 SIGNATURE: *Curt Kobilarcsik*
 DATE: 7-14-14 LICENSE NO. 24756

DRAWN BY: ZB DATE: 07-07-14
 DESIGN BY: MN DATE: 07-07-14
 CHECKED BY: CAK DATE: 07-11-14



ANOKA COUNTY
HIGHWAY DEPT.

S.A.P. 002-621-010

MISCELLANEOUS DETAILS

DESIGN "P-1" RECLAIM PAVEMENT DESIGN

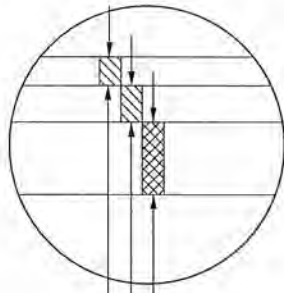

2.0" BITUMINOUS WEAR (SPWEB340F)
2.5" BITUMINOUS NON-WEAR (SPNWB330B)
RECLAIM AGGREGATE BASE, CLASS 5

DESIGN "F-1" MAINLINE PAVEMENT DESIGN

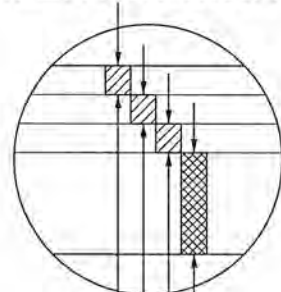

2.0" BITUMINOUS WEAR (SPWEB340F)
2.0" BITUMINOUS NON-WEAR (SPNWB330B)
2.0" BITUMINOUS NON-WEAR (SPNWB330B)
7.0" AGGREGATE BASE, CLASS 5

NOTES:

- ① 13.0' LEFT / THRU LANE, STA. 93+40.90 TO STA. 98+55.00.
- ② SEE TURN LANE LOCATION CHART ON NEXT PAGE.
- ③ SEE CROSS-SECTION / PROFILE SHEETS FOR SPECIAL DITCH.
- ④ SEE PLAN PROFILE SHEETS FOR R/W

GENERAL NOTES:

- 1) ALL CROSS SLOPES ARE EXPRESSED IN FT/FT.
- 2) ALL STATIONINGS ON CSAH 21 BASED ON C/L ALIGNMENT.
- 3) SEE CONSTRUCTION PLAN SHEETS 40 - 45 AND CHART ON NEXT PAGE FOR TURN LANE LOCATIONS.

CSAH 21 (CENTERVILLE RD.)
STA. 93+40.90 - STA. 98+55.22

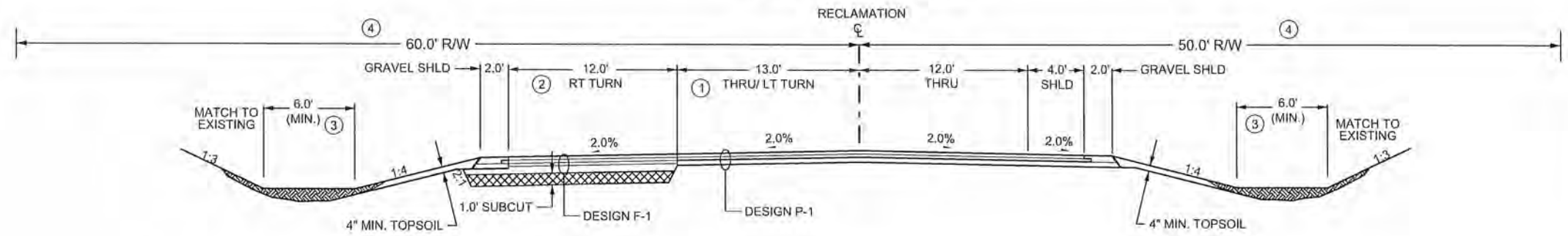

CSAH 21 (CENTERVILLE RD.)
STA. 98+55.22 - STA. 111+19.42

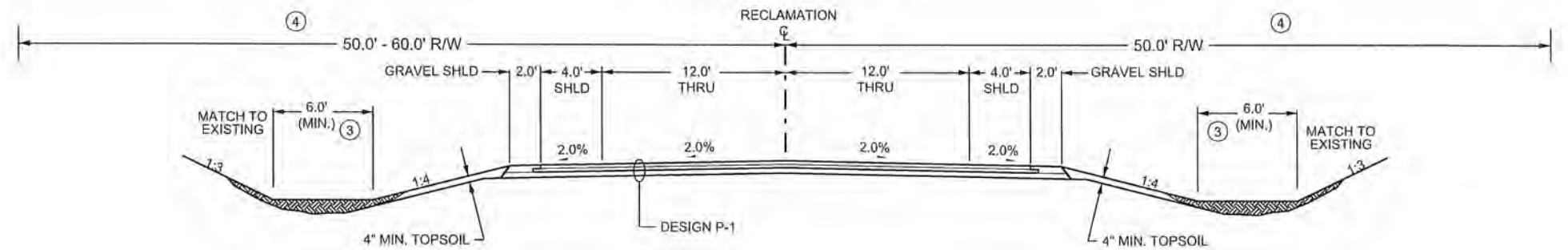

CSAH 21 (CENTERVILLE RD.)
STA. 110+40.00 TO STA. 118+10.00 (END RECLAIM)

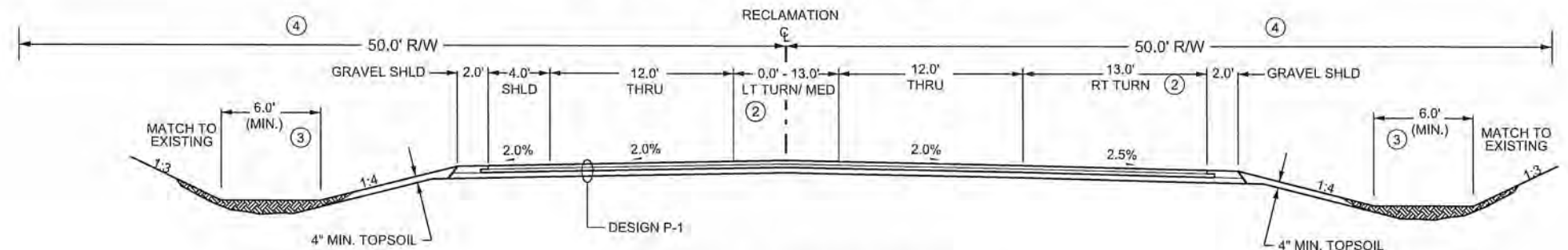

CSAH 21 (CENTERVILLE RD.)
STA. 118+10.00 (BEGIN RECONSTRUCT) TO STA. 120+07.29

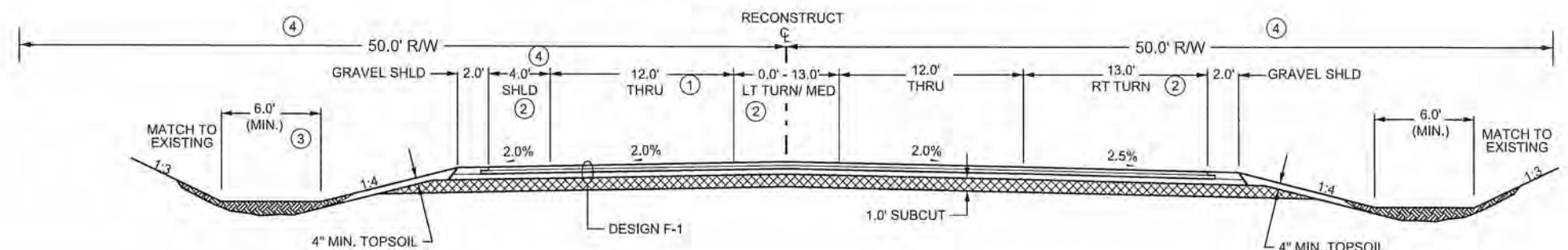

NO	DATE	BY	CKD	APPR	REVISION

NAME: P:\02-621-10\Plan\6_Typical-1.dgn 07/11/2014 1:37:38 PM

I HEREBY CERTIFY THAT THIS PLAN WAS PREPARED BY ME OR UNDER MY DIRECT SUPERVISION AND THAT I AM A DULY LICENSED PROFESSIONAL ENGINEER UNDER THE LAWS OF THE STATE OF MINNESOTA.

PRINT NAME: CURT A. KOBILARCSIK
SIGNATURE: *Curt Kobilarsik*
DATE: 7-14-14 LICENSE NO. 24756

DRAWN BY: ZB DATE: 07-07-14
DESIGN BY: MN DATE: 07-07-14
CHECKED BY: CAK DATE: 07-11-14

ANOKA COUNTY HIGHWAY DEPT.

S.A.P. 002-621-010

CSAH 21 (CENTERVILLE RD.)
 STA. 120+79.39 TO STA. 125+32.06
 STA. 130+69.12 TO STA. 134+38.77
 STA. 137+43.03 TO STA. 140+56.21
 STA. 144+45.78 TO STA. 146+99.53

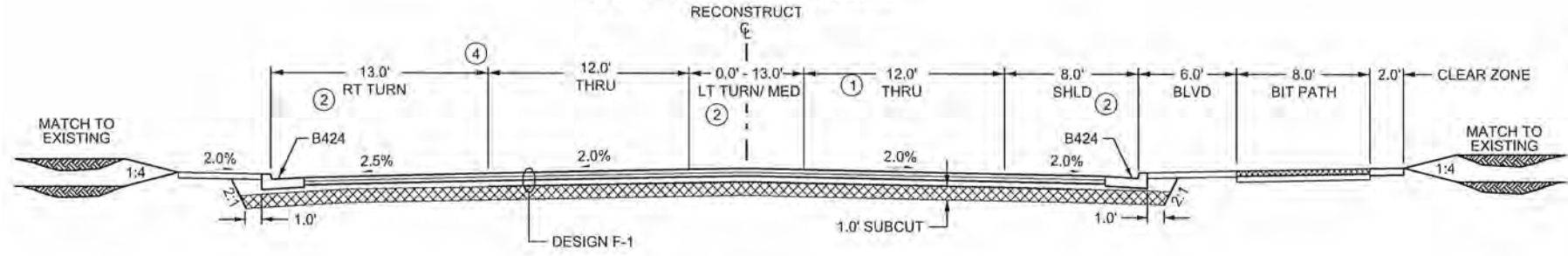

CSAH 21 (CENTERVILLE RD.)
 STA 125+32.06 TO STA 130+69.12

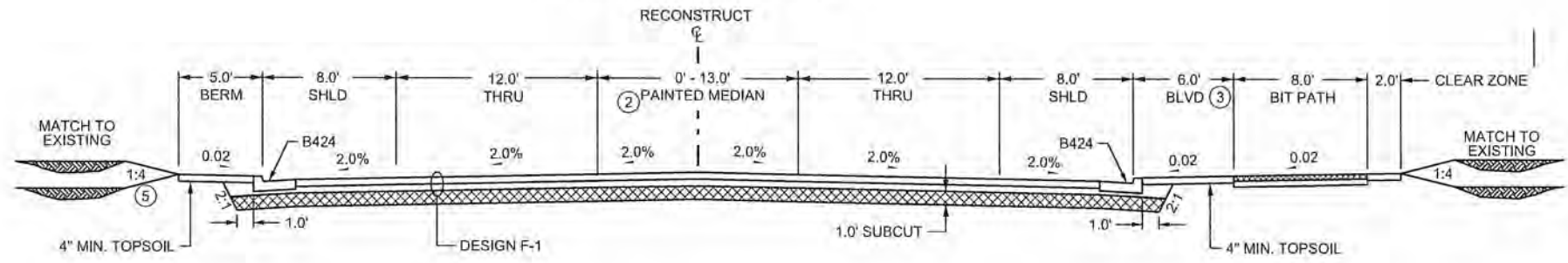

CSAH 21 (CENTERVILLE RD.)
 STA. 134+38.77 TO STA 137+75.86
 STA. 140+56.21 TO STA. 144+45.76
 STA. 146+99.53 TO STA. 152+36.06

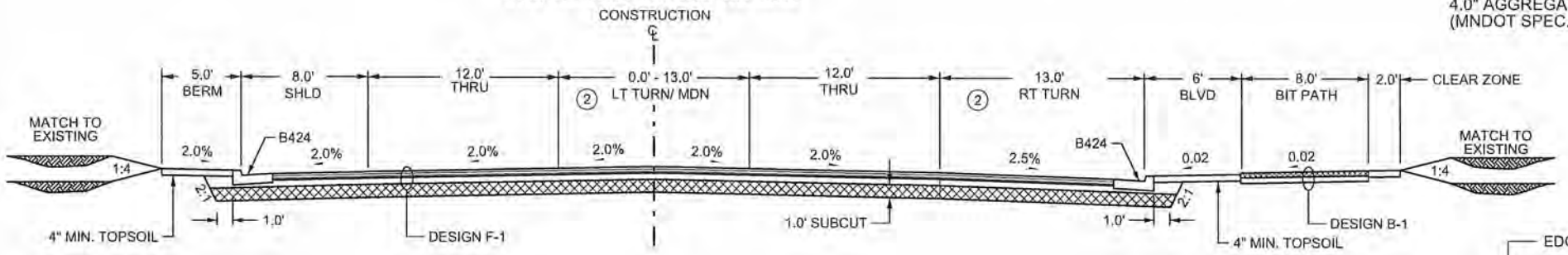

CSAH 21 (CENTERVILLE RD.)
 STA 152+36.06 - STA 155+85.77
 CONSTRUCTION (RT TURN LANE)

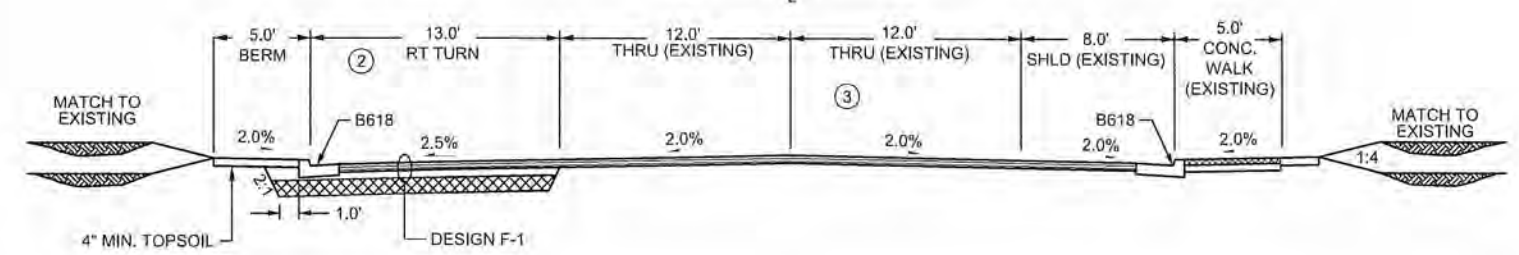

TURN LANE LOCATIONS					
ALIGNMENT	STATION TO STATION*	LOCATION	DESCRIPTION	TAPER	
CL 21	93+66 98+55	LT.	RIGHT TURN	1:15	
CL 21	114+79 119+62	RT.	LEFT TURN	1:15	
CL 21	114+95 119+63	RT.	RIGHT TURN	1:15	
CL 21	120+52 125+50	LT.	LEFT TURN	1:15	
CL 21	120+62 123+77	LT.	RIGHT TURN	1:15	
CL 21	131+30 134+76	LT.	RIGHT TURN	1:15	
CL 21	133+86 137+31	RT.	RIGHT TURN	1:15	
CL 21	140+44 143+97	RT.	LEFT TURN	1:10	
CL 21	140+56 144+01	RT.	RIGHT TURN	1:15	
CL 21	144+91 148+86	LT.	LEFT TURN	1:15	
CL 21	144+92 148+37	LT.	RIGHT TURN	1:15	
CL 21	146+25 151+94	RT.	RIGHT TURN	1:15	
CL 21	152+78 155+46	LT.	RIGHT TURN	-	

* STATION RANGE INCLUDES TAPER SECTION.

BITUMINOUS EDGE AND AGGREGATE SHOULDERING DETAIL

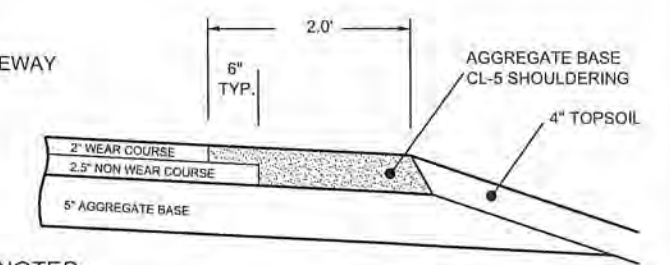

NOTES:

- ① 13.0' LT. & THRU LANE, STA. 93+40.90 TO STA. 98+55.00.
- ② SEE TURN LANE LOCATION CHART.
- ③ MILL & OVERLAY ALL EXCEPT RTL FROM STA 152+78 TO STA 155+86

GENERAL NOTES:

- 1) ALL CROSS SLOPES ARE EXPRESSED IN FT/FT.
- 2) ALL STATIONINGS ON CSAH 21 BASED ON C/L ALIGNMENT.
- 3) SEE CONSTRUCTION PLAN SHEETS 40 - 45 AND CHART BELOW FOR TURN LANE LOCATIONS.

DESIGN "B-1" BIKE PATH/DRIVEWAY PAVEMENT DESIGN

2.5" TYPE SP 12.5 WEARING COURSE MIXTURE (2,B) (SPWEB230B)
 4.0" AGGREGATE BASE, CLASS 5 (MNDOT SPEC. 2211) (CRUSHED)

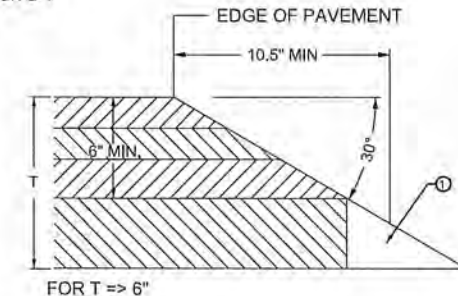

FOR T >= 6"

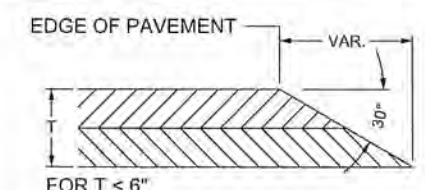

FOR T < 6"

① OPTIONAL DESIGN EXTENDS SAFETY EDGE DEEPER THAN 6" AND WIDER THAN 10.5". SEE PLAN DESIGN DETAILS.

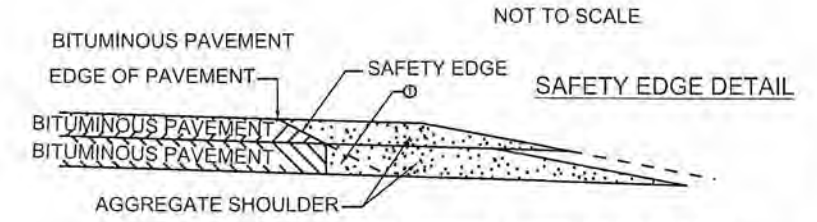

① OPTIONAL DESIGN EXTENDS SAFETY EDGE DEEPER THAN 6" AND WIDER THAN 10.5". SEE PLAN DESIGN DETAILS.

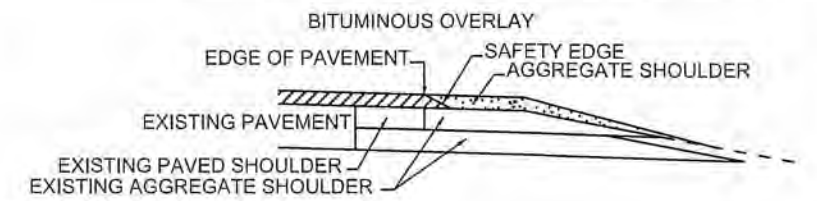

NO	DATE	BY	CKD	APPR	REVISION

NAME: P:\02-621-10\Plan16_Typical-1.dgn 07/11/2014 1:37:38 PM

I HEREBY CERTIFY THAT THIS PLAN WAS PREPARED BY ME OR UNDER MY DIRECT SUPERVISION AND THAT I AM A DULY LICENSED PROFESSIONAL ENGINEER UNDER THE LAWS OF THE STATE OF MINNESOTA.
 PRINT NAME: CURT A. KOBIARCSIK
 SIGNATURE: *Curt Kobiarcsik*
 DATE: 7-14-14 LICENSE NO. 24756

DRAWN BY: ZB DATE: 07-07-14
 DESIGN BY: MN DATE: 07-07-14
 CHECKED BY: CAK DATE: 07-11-14

ANOKA COUNTY HIGHWAY DEPT.

S.A.P. 002-621-010

CSAH 21 PROPOSED TYPICAL SECTIONS
 Sheet 20 of 147 Sheets

PLOTTED/REVISED:
 \$\$\$@DATE@\$\$\$

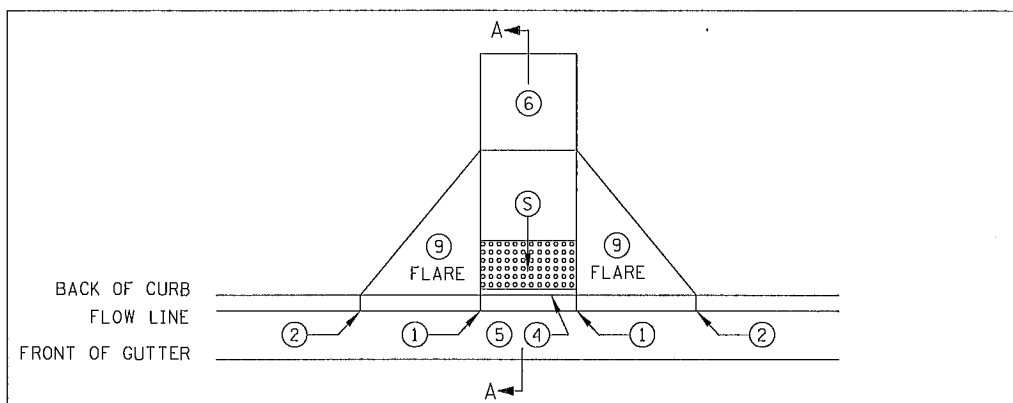

PERPENDICULAR

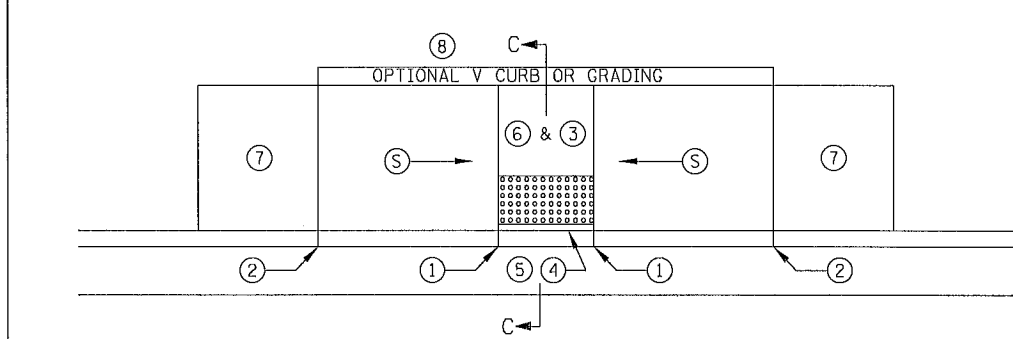

PARALLEL

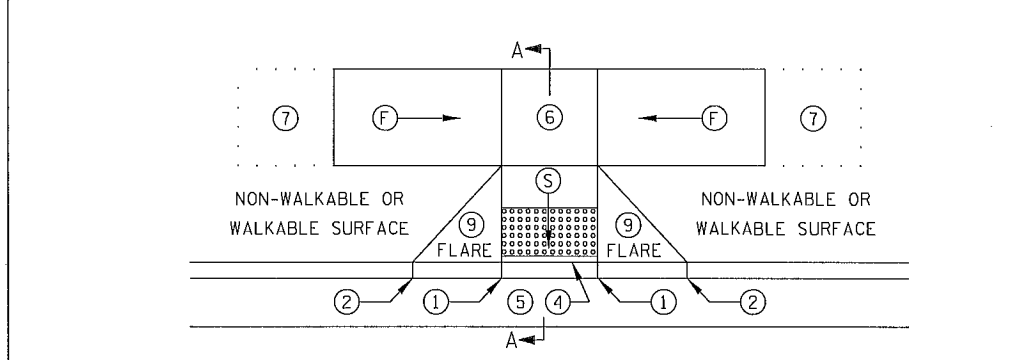

TIERED PERPENDICULAR

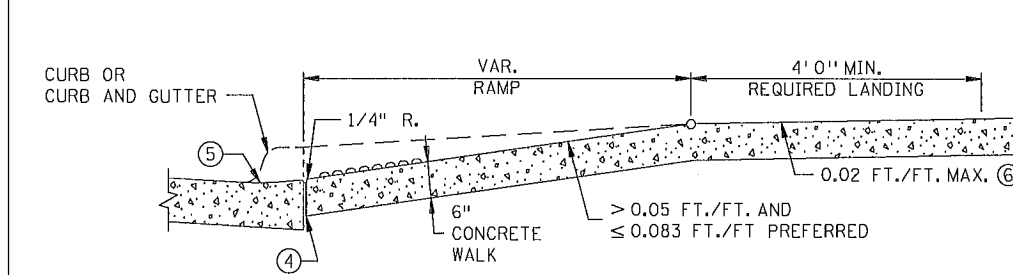

SECTION A-A
 PERPENDICULAR/TIERED/DIAGONAL

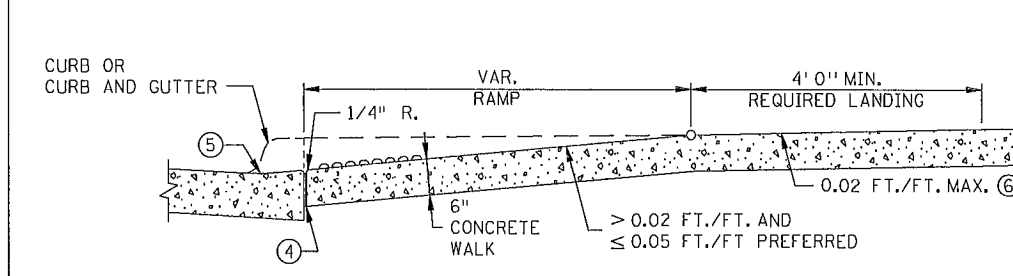

SECTION B-B
 FAN

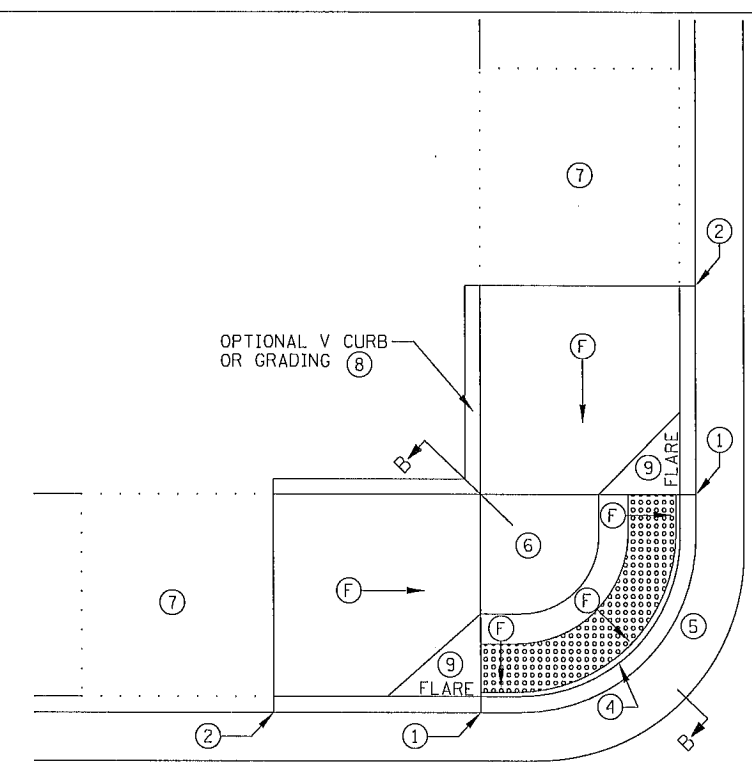

FAN

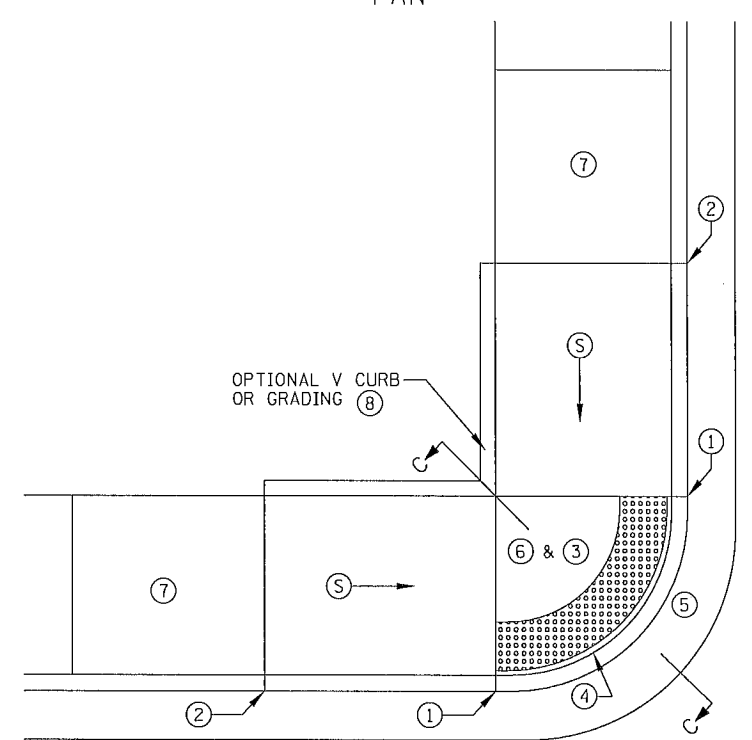

DEPRESSED CORNER

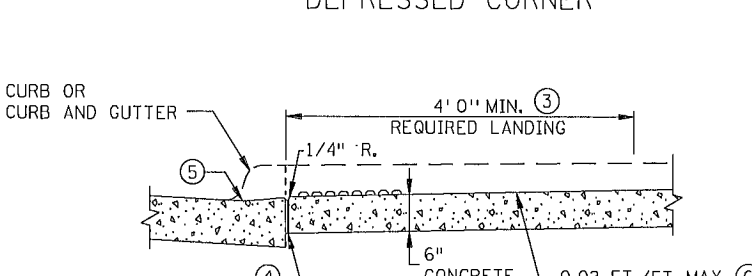

SECTION C-C
 PARALLEL/DEPRESSED CORNER

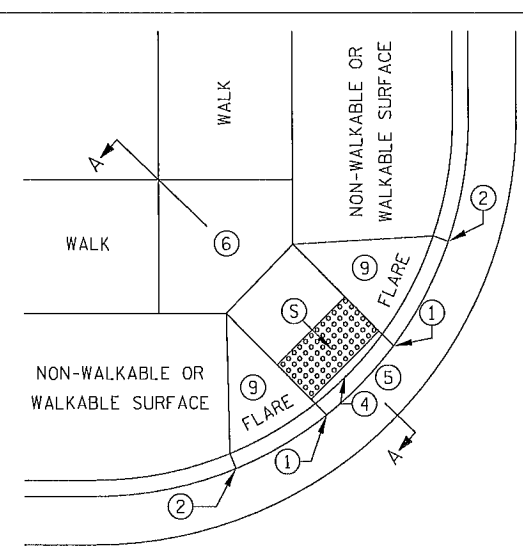

DIAGONAL 10

- NOTES:
- LANDINGS SHALL BE LOCATED ANYWHERE THE PEDESTRIAN ACCESS ROUTE CHANGES DIRECTION, AT THE TOP OF RAMPS THAT HAVE RUNNING SLOPES GREATER THAN 5.0%, AND IF THE APPROACHING WALK IS INVERSE GRADE.
 - INITIAL CURB RAMP LANDINGS SHALL BE CONSTRUCTED WITHIN 15' FROM THE BACK OF CURB, WITH 6' FROM THE BACK OF CURB BEING THE PREFERRED DISTANCE.
 - SECONDARY CURB RAMP LANDINGS ARE REQUIRED FOR EVERY 30" OF VERTICAL RISE WHEN THE LONGITUDINAL SLOPE IS GREATER THAN 5.0%.
 - CONTRACTION JOINTS SHALL BE CONSTRUCTED ALONG ALL GRADE BREAKS.
 - ALL GRADE BREAKS WITHIN THE PAR SHALL BE PERPENDICULAR TO THE PATH OF TRAVEL.
 - TO ENSURE RAMPS AND LANDINGS ARE PROPERLY CONSTRUCTED, LANDINGS MAY BE CAST SEPARATELY. FOLLOW SIDEWALK REINFORCEMENT DETAILS ON SHEET 5 WHEN LANDINGS ARE CAST SEPARATELY.
 - ALL SLOPES ARE ABSOLUTE, RATHER THAN RELATIVE TO SIDEWALK/ROADWAY GRADES.
 - TOP OF CURB SHALL MATCH PROPOSED ADJACENT WALK GRADE.
 - 4' MINIMUM WIDTH OF DETECTABLE WARNING IS REQUIRED FOR ALL RAMPS. DETECTABLE WARNINGS SHALL CONTINUOUSLY EXTEND FOR A MINIMUM OF 24" IN THE PATH OF TRAVEL. SHARED USE PATHS SHALL HAVE DETECTABLE WARNING ACROSS THE ENTIRE WIDTH OF PATH WHEN THE PATH CROSSES A ROAD.
 - SEE STANDARD PLATE 7038 AND SHEET 4 OF 5 FOR ADDITIONAL DETAILS ON DETECTABLE WARNING.
 - 1 0" CURB HEIGHT.
 - 2 FULL CURB HEIGHT.
 - 3 DETECTABLE WARNINGS MAY BE PART OF 4' X 4' LANDING AREA IF IT IS NOT FEASIBLE TO CONSTRUCT THE LANDING OUTSIDE OF THE DETECTABLE WARNING AREA.
 - 4 1/2" PREFORMED JOINT FILLER MATERIAL AASHTO M 213. JOINT FILLER SHALL BE PLACED FLUSH WITH THE BACK OF CURB AND ADJACENT SIDEWALK. JOINT SHALL BE FREE OF DEBRIS. RECTANGULAR DETECTABLE WARNINGS SHALL BE SETBACK 3" FROM THE BACK OF CURB. RADIAL DETECTABLE WARNINGS SHALL BE SETBACK 3" MINIMUM TO 6" MAXIMUM FROM THE BACK OF CURB.
 - 5 SEE PEDESTRIAN ACCESS ROUTE CURB AND GUTTER DETAIL FOR INFORMATION ON CONSTRUCTING CURB AND GUTTER AT CURB OPENINGS. SEE SHEET NO. 3 OF 5.
 - 6 4' BY 4' MIN. LANDING WITH MAX. 2.0% SLOPE IN ALL DIRECTIONS.
 - 7 IF LONGITUDINAL SLOPE IS GREATER THAN 5.0%, 4' X 4' MIN. LANDING WITH MAX 2.0% SLOPE IN ALL DIRECTIONS REQUIRED.
 - 8 V CURB, IF USED, SHALL BE PLACED OUTSIDE THE SIDEWALK LIMITS WHEN RIGHT OF WAY ALLOWS. SEE SHEET 5 OF 5.
 - 9 SEE SHEET 4 OF 5, TYPICAL SIDE TREATMENT OPTIONS, FOR DETAILS ON FLARES AND RETURNED CURBS.
 - 10 DIAGONAL RAMPS SHOULD ONLY BE USED AFTER ALL OTHER CURB RAMP TYPES HAVE BEEN EVALUATED AND DEEMED IMPRACTICAL.

LEGEND	
THESE LONGITUDINAL SLOPE RANGES SHALL BE THE STARTING POINT. IF SITE CONDITIONS WARRANT, LONGITUDINAL SLOPES UP TO 8.3% OR FLATTER ARE ALLOWED.	
(S)	INDICATES PEDESTRIAN RAMP - SLOPE SHALL BE BETWEEN 5.0% MINIMUM AND 8.3% MAXIMUM IN THE DIRECTION SHOWN AND THE CROSS SLOPE SHALL NOT EXCEED 2.0%
(F)	INDICATES PEDESTRIAN RAMP - SLOPE SHALL BE GREATER THAN 2.0% AND LESS THAN 5.0% IN THE DIRECTION SHOWN AND CROSS SLOPE SHALL NOT EXCEED 2.0%

FILE NAME: \$\$\$@USER\$NAME@\$\$
 PATH & FILENAME: \$\$\$@PATH\$FILENAME@\$\$\$

PLOTTED/REVISED:
 \$\$\$@DATE@\$\$\$

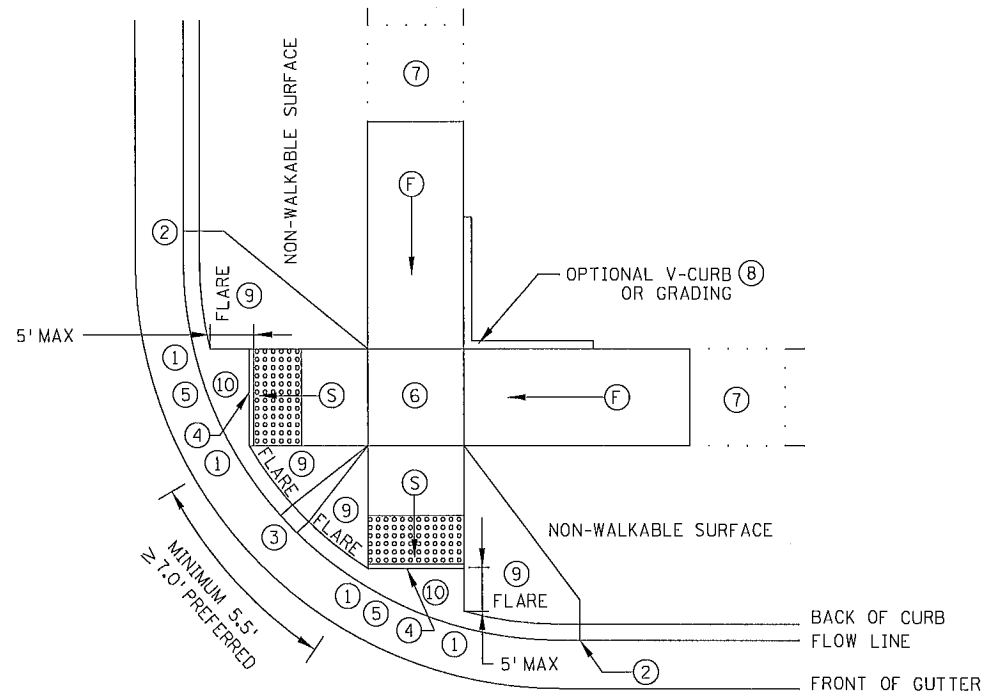

ADJACENT TO NON-WALKABLE SURFACE

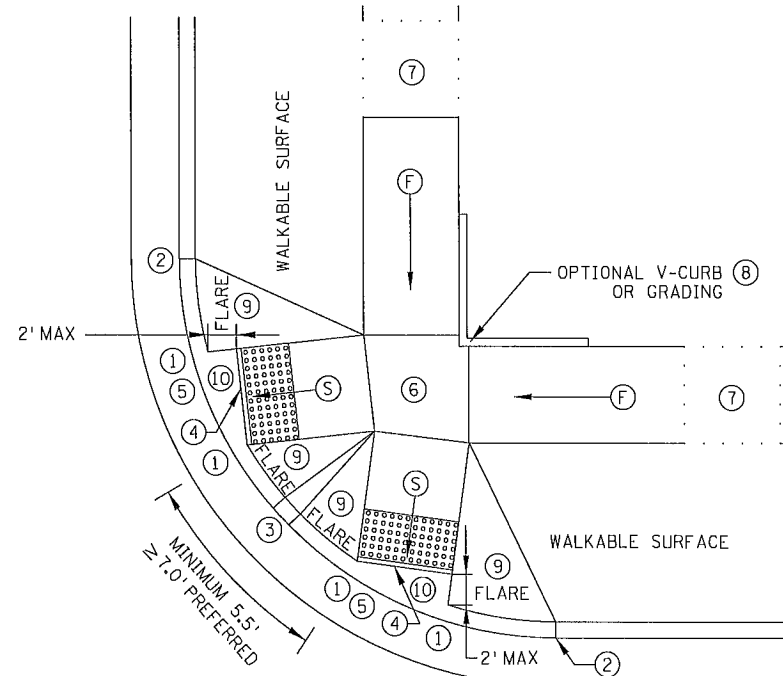

ADJACENT TO WALKABLE SURFACE

COMBINED DIRECTIONAL 15

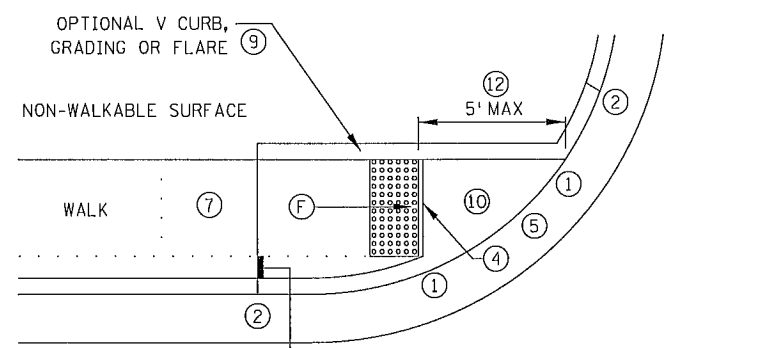

ONE-WAY DIRECTIONAL

IF NON-CONCRETE BLVD. IS CONSTRUCTED AND IS LESS THAN 2' IN WIDTH AT TOP OF CURB TRANSITION, PAVE CONCRETE RAMP WIDTH TO ADJACENT BACK OF CURB.

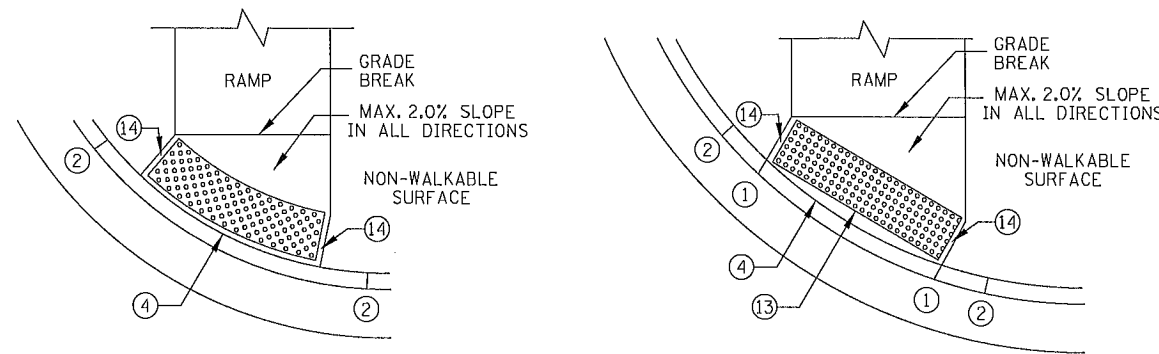

DETECTABLE WARNING PLACEMENT WHEN SETBACK CRITERIA IS EXCEEDED

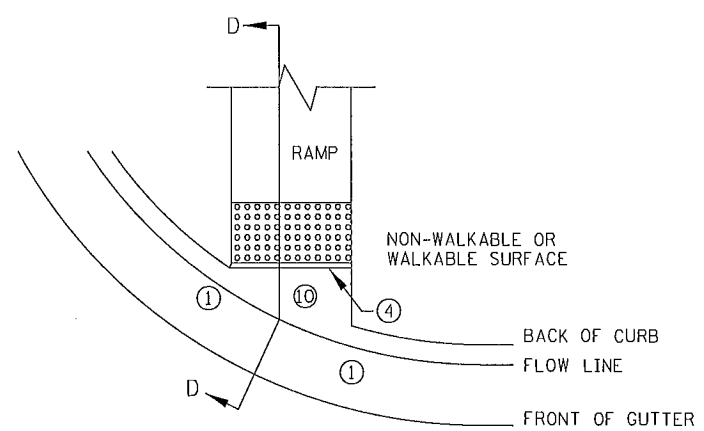

CURB FOR DIRECTIONAL RAMPS 11

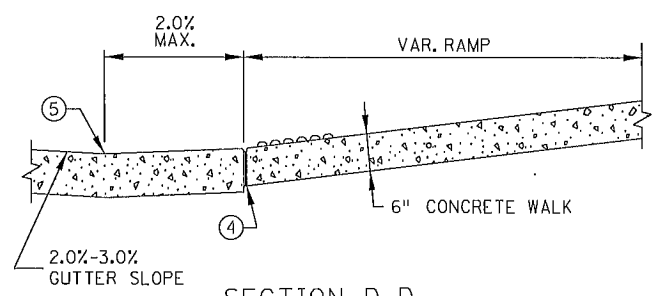

SECTION D-D

NOTES:

- LANDINGS SHALL BE LOCATED ANYWHERE THE PEDESTRIAN ACCESS ROUTE CHANGES DIRECTION, AT THE TOP OF RAMPS THAT HAVE RUNNING SLOPES GREATER THAN 5.0%, AND IF THE APPROACHING WALK IS INVERSE GRADE.
- INITIAL CURB RAMP LANDINGS SHALL BE CONSTRUCTED WITHIN 15' FROM THE BACK OF CURB, WITH 6' FROM THE BACK OF CURB BEING THE PREFERRED DISTANCE.
- SECONDARY CURB RAMP LANDINGS ARE REQUIRED FOR EVERY 30" OF VERTICAL RISE WHEN THE LONGITUDINAL SLOPE IS GREATER THAN 5.0%.
- CONTRACTION JOINTS SHALL BE CONSTRUCTED ALONG ALL GRADE BREAKS.
- ALL GRADE BREAKS WITHIN THE PAR SHALL BE PERPENDICULAR TO THE PATH OF TRAVEL.
- TO ENSURE RAMPS AND LANDINGS ARE PROPERLY CONSTRUCTED, LANDINGS MAY BE CAST SEPARATELY, FOLLOW SIDEWALK REINFORCEMENT DETAILS ON SHEET 5 WHEN LANDINGS ARE CAST SEPARATELY.
- ALL SLOPES ARE ABSOLUTE, RATHER THAN RELATIVE TO SIDEWALK/ROADWAY GRADES.
- TOP OF CURB SHALL MATCH PROPOSED ADJACENT WALK GRADE.
- 4' MINIMUM WIDTH OF DETECTABLE WARNING IS REQUIRED FOR ALL RAMPS. DETECTABLE WARNINGS SHALL CONTINUOUSLY EXTEND FOR A MINIMUM OF 24" IN THE PATH OF TRAVEL. SHARED USE PATHS SHALL HAVE DETECTABLE WARNING ACROSS THE ENTIRE WIDTH OF PATH WHEN THE PATH CROSSES A ROAD.

SEE STANDARD PLATE 703B AND SHEET 4 OF 5 FOR ADDITIONAL DETAILS ON DETECTABLE WARNING.

- 1 0" CURB HEIGHT.
- 2 FULL CURB HEIGHT.
- 3 3" MINIMUM CURB HEIGHT, 4" PREFERRED.
- 4 1/2" PREFORMED JOINT FILLER MATERIAL AASHTO M 213. JOINT FILLER SHALL BE PLACED FLUSH WITH THE BACK OF CURB AND ADJACENT SIDEWALK. JOINT SHALL BE FREE OF DEBRIS. RECTANGULAR DETECTABLE WARNINGS SHALL BE SETBACK 3" FROM THE BACK OF CURB. RADIAL DETECTABLE WARNINGS SHALL BE SETBACK 3" MIN. TO 6" MAX. FROM THE BACK OF CURB.
- 5 SEE PEDESTRIAN ACCESS ROUTE CURB AND GUTTER DETAIL FOR INFORMATION ON CONSTRUCTING CURB AND GUTTER AT CURB OPENINGS. SEE SHEET NO. 3 OF 5.
- 6 4' BY 4' MIN. LANDING WITH MAX. 2.0% SLOPE IN ALL DIRECTIONS.
- 7 IF LONGITUDINAL SLOPE IS GREATER THAN 5.0%, 4' X 4' MIN. LANDING WITH MAX 2.0% SLOPE IN ALL DIRECTIONS REQUIRED.
- 8 V CURB, IF USED, SHALL BE PLACED OUTSIDE THE SIDEWALK LIMITS WHEN RIGHT OF WAY ALLOWS.
- 9 SEE SHEET 4 OF 5, TYPICAL SIDE TREATMENT OPTIONS, FOR DETAILS ON FLARES AND RETURNED CURBS.
- 10 MAX. 2.0% SLOPE IN ALL DIRECTIONS IN FRONT OF GRADE BREAK AND DRAIN TO FLOW LINE. SHALL BE CONSTRUCTED INTEGRAL WITH CURB AND GUTTER.
- 11 TO BE USED FOR ALL DIRECTIONAL RAMPS.
- 12 PLACE DOMES AT THE BACK OF CURB WHEN ALLOWABLE SETBACK CRITERIA IS EXCEEDED.
- 13 RECTANGULAR DETECTABLE WARNINGS MAY BE SETBACK 9" FROM THE BACK OF CURB WITH CORNERS SET 3" FROM BACK OF CURB. IF 9" SETBACK IS EXCEEDED USE RADIAL DETECTABLE WARNINGS.
- 14 WHEN NO CONCRETE FLARES ARE PROPOSED, THE CONCRETE WALK SHALL BE FORMED AND CONSTRUCTED PERPENDICULAR TO THE BACK OF CURB. MAINTAIN 3" BETWEEN EDGE OF DOMES AND EDGE OF CONCRETE.
- 15 FRONT EDGE OF DETECTABLE WARNING SHALL BE SET BACK 2' MAXIMUM WHEN ADJACENT TO WALKABLE SURFACE, AND 5' MAXIMUM WHEN ADJACENT TO NON-WALKABLE SURFACE WITH ONE CORNER SET 3" FROM BACK OF CURB. WHETHER A SURFACE IS WALKABLE OR NOT SHALL BE DETERMINED BY THE ENGINEER

LEGEND	
THESE LONGITUDINAL SLOPE RANGES SHALL BE THE STARTING POINT. IF SITE CONDITIONS WARRANT, LONGITUDINAL SLOPES UP TO 8.3% OR FLATTER ARE ALLOWED.	
(S)	INDICATES PEDESTRIAN RAMP - SLOPE SHALL BE BETWEEN 5.0% MINIMUM AND 8.3% MAXIMUM IN THE DIRECTION SHOWN AND THE CROSS SLOPE SHALL NOT EXCEED 2.0%
(F)	INDICATES PEDESTRIAN RAMP - SLOPE SHALL BE GREATER THAN 2.0% AND LESS THAN 5.0% IN THE DIRECTION SHOWN AND CROSS SLOPE SHALL NOT EXCEED 2.0%

STANDARD PLAN SHEET NO.
 5-297.250 (2 OF 5)
 STANDARD APPROVED:
 APRIL 10, 2013

PEDESTRIAN CURB RAMP DETAILS

STATE PROJ. NO. 002-621-010

SHEET NO. 22 OF 147 SHEETS

FILE NAME: \$\$\$@USER\$NAME@\$\$
 PATH & FILENAME: \$\$\$@PATH\$FILENAME@\$\$\$
 @FILENAME@

PLOTTED/REVISED:
 \$\$\$@DATE@\$\$\$

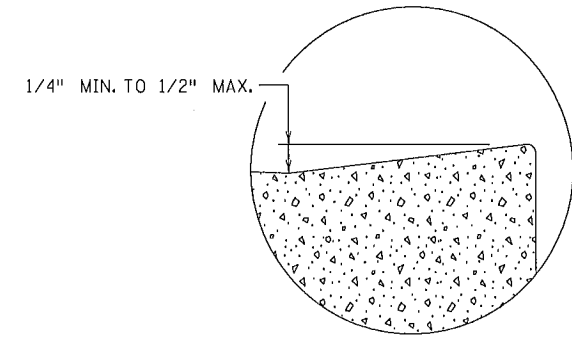
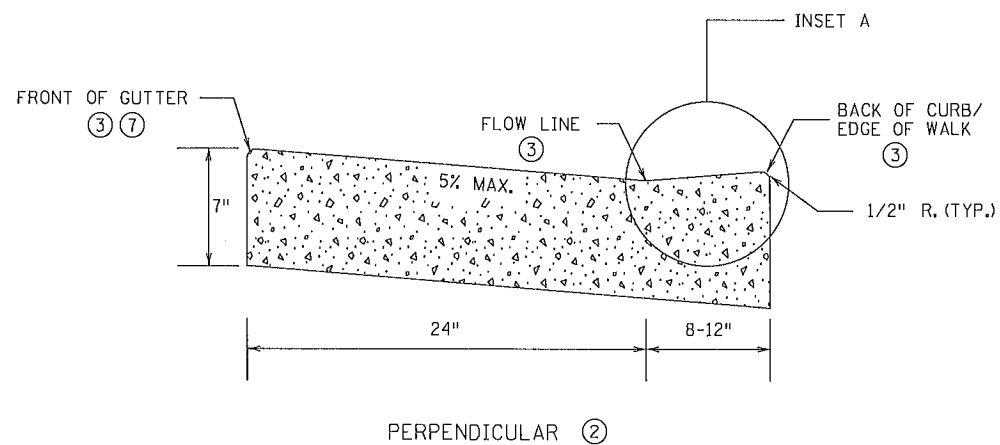
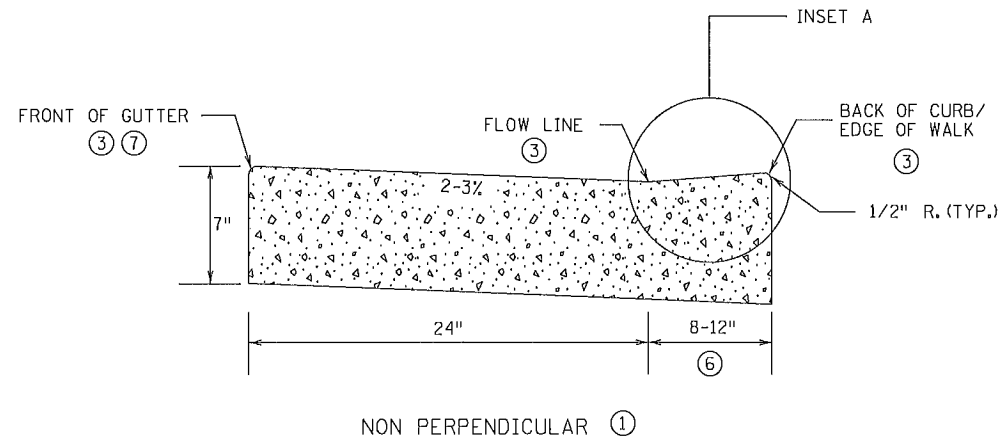

PEDESTRIAN ACCESS ROUTE
 CURB & GUTTER DETAIL

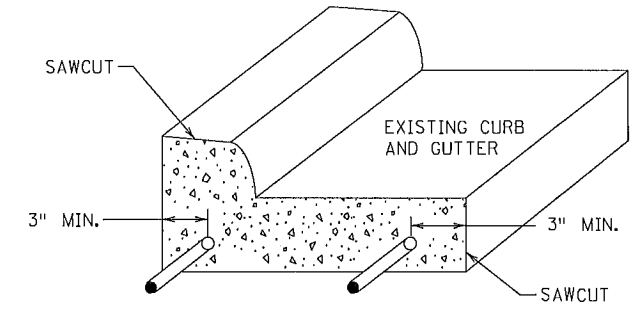
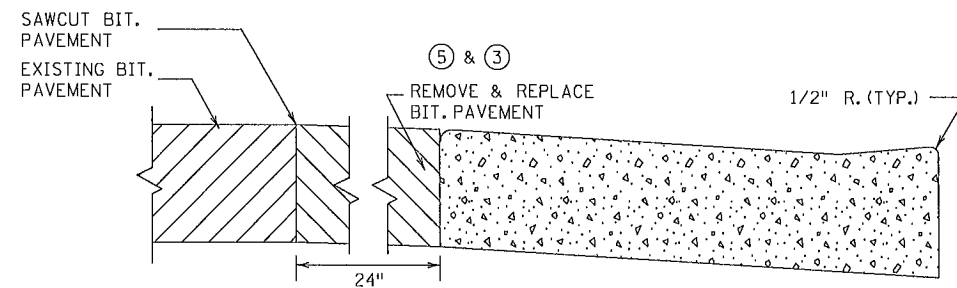
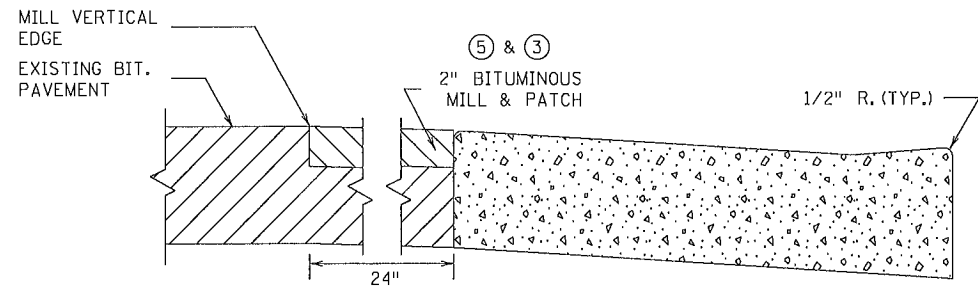

CURB AND GUTTER
 REINFORCEMENT
 FOR USE ON CURB RAMP RETROFITS

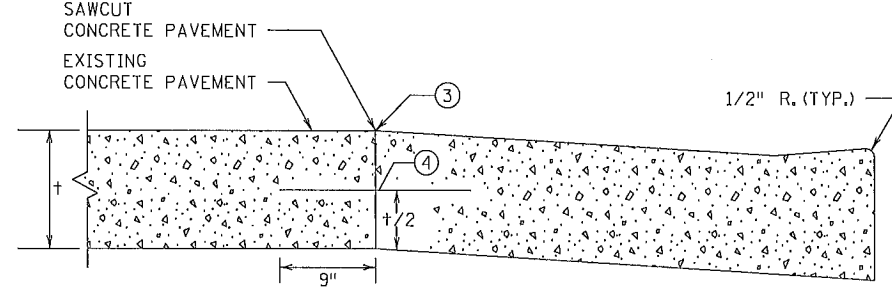
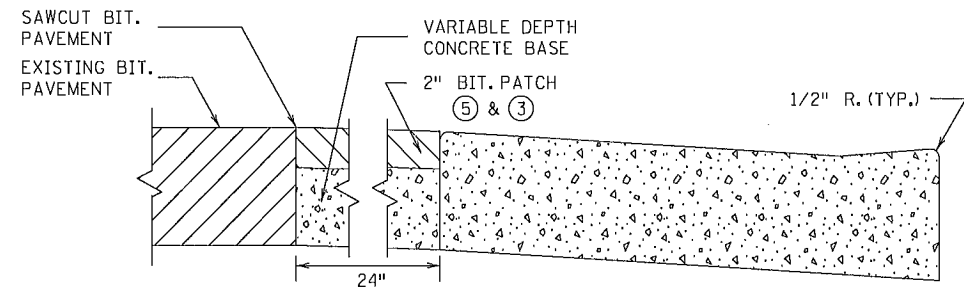

PAVEMENT TREATMENT OPTIONS
 IN FRONT OF CURB & GUTTER
 FOR USE ON CURB RAMP RETROFITS

- NOTES:
- POSITIVE FLOW LINE DRAINAGE SHALL BE MAINTAINED THROUGH THE PEDESTRIAN ACCESS ROUTE (PAR) AT A 2% MAXIMUM.
 - NO PONDING SHALL BE PRESENT IN THE PAR.
 - ANY VERTICAL LIP THAT OCCURS AT THE FLOW LINE SHALL NOT BE GREATER THAN 1/4 INCH.
 - ① FOR USE AT CURB CUTS WHERE THE PEDESTRIAN'S PATH OF TRAVEL IS ASSUMED NON PERPENDICULAR TO THE GUTTER FLOW LINE. RAMP TYPES INCLUDE: FANS, DEPRESSED CORNERS, & ONE WAY AND COMBINED DIRECTIONALS.
 - ② FOR USE AT CURB CUTS WHERE THE PEDESTRIAN'S PATH OF TRAVEL IS ASSUMED PERPENDICULAR TO THE GUTTER FLOW LINE. RAMP TYPES INCLUDE: PERPENDICULAR, TIERED PERPENDICULAR, PARALLEL, AND DIAGONAL RAMPS.
 - ③ THERE SHALL BE NO VERTICAL DISCONTINUITIES GREATER THAN 1/4".
 - ④ DRILL AND GROUT NO. 4 EPOXY-COATED 18" LONG TIE BARS AT 30" CENTER TO CENTER INTO EXISTING CONCRETE PAVEMENT.
 - ⑤ ELEVATION CHANGE TAKES PLACE FROM THE EXISTING TO NEW FRONT OF GUTTER. PATCH IS USED TO MATCH THE NEW GUTTER FACE INTO THE EXISTING ROADWAY.
 - ⑥ VARIABLE WIDTH FOR DIRECTIONAL CURB APPLICATIONS.
 - ⑦ TOP FRONT OF GUTTER SHALL BE CONSTRUCTED FLUSH WITH PROPOSED ADJACENT PAVEMENT ELEVATION. PAR GUTTER SHALL NOT BE OVERLAID.
 - ⑧ WHERE PLAN SPECIFIES, DRILL AND GROUT 2 - NO. 4 X 12" LONG REINFORCEMENT BARS (EPOXY COATED).

USER NAME: \$\$\$@USER\$NAME@\$\$
 PATH & FILENAME: \$\$\$@PATH\$FILENAME@\$\$\$

FILE NAME:
 @FILENAME@

STANDARD PLAN SHEET NO. 5-297.250 (3 OF 5)	PEDESTRIAN CURB RAMP DETAILS
STANDARD APPROVED: APRIL 10, 2013	
STATE PROJ. NO. 002-621-010	SHEET NO. 23 OF 147 SHEETS

PLOTTED/REVISED:
\$\$\$\$DATE\$\$\$\$

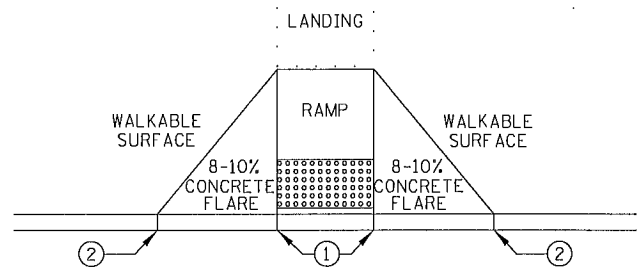

PAVED FLARES
ADJACENT TO WALKABLE SURFACE

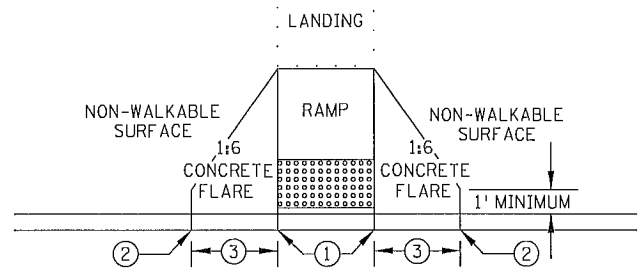

PAVED FLARES
ADJACENT TO NON-WALKABLE SURFACE

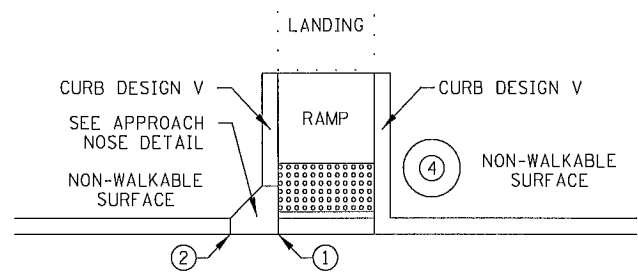

DIRECTION OF TRAFFIC
RETURNED CURB

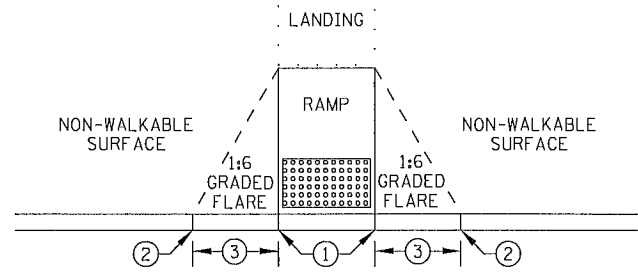

GRADED FLARES

TYPICAL SIDE TREATMENT OPTIONS (5)

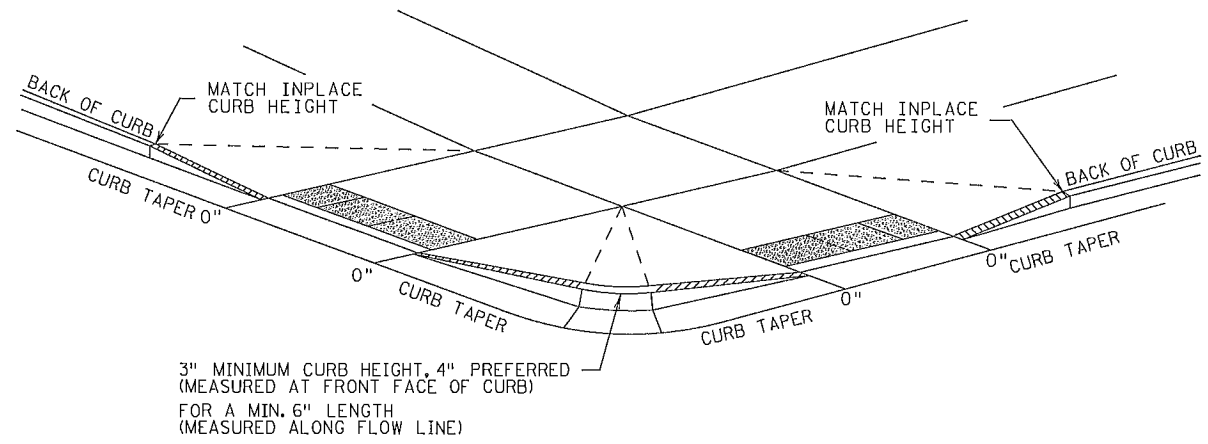

3" MINIMUM CURB HEIGHT, 4" PREFERRED
(MEASURED AT FRONT FACE OF CURB)
FOR A MIN. 6" LENGTH
(MEASURED ALONG FLOW LINE)

DETECTABLE EDGE WITH
CURB AND GUTTER (8)

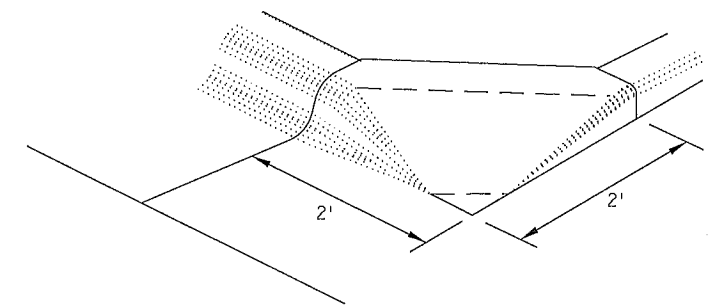

SECTION A-A

APPROACH NOSE DETAIL
FOR DOWNSTREAM SIDE OF TRAFFIC

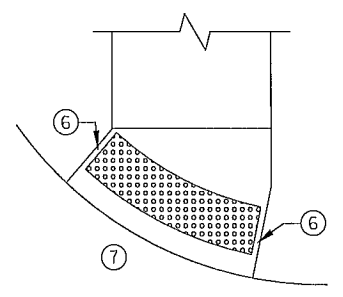

RADIAL DETECTABLE WARNING

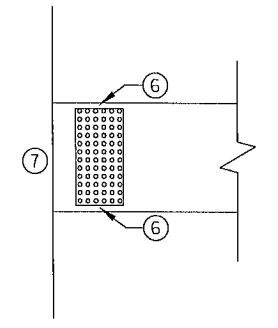

RECTANGULAR DETECTABLE WARNING

DETECTABLE EDGE WITHOUT CURB AND GUTTER

NOTES:

SEE STANDARD PLATE 7038 AND THIS SHEET FOR ADDITIONAL DETAILS ON DETECTABLE WARNING. WHETHER A SURFACE IS WALKABLE OR NOT SHALL BE DETERMINED BY THE ENGINEER. CONCRETE FLARE LENGTHS ADJACENT TO NON-WALKABLE SURFACES SHOULD BE LESS THAN 8' LONG MEASURED ALONG THE RAMPS FROM THE BACK OF CURB.

- (1) 0" CURB HEIGHT.
- (2) FULL CURB HEIGHT.
- (3) 2' - 3' FLARE.
- (4) IMMOVABLE OBJECT OR OBSTRUCTION.
- (5) SIDE TREATMENTS ARE APPLICABLE TO ALL RAMP TYPES AND SHOULD BE IMPLEMENTED AS NEEDED ON ALL RAMPS AS FIELD CONDITIONS DICTATE. THE ENGINEER SHALL DETERMINE THE RAMP SIDE TREATMENTS BASED ON MAINTENANCE OF BOTH ROADWAY AND SIDEWALK, ADJACENT PROPERTY CONSIDERATIONS, AND MITIGATING CONSTRUCTION IMPACTS.
- (6) WHEN NO CONCRETE FLARES ARE PROPOSED, THE CONCRETE WALK SHALL BE FORMED AND CONSTRUCTED PERPENDICULAR TO THE EDGE OF ROADWAY. MAINTAIN 3" BETWEEN EDGE OF DOMES AND EDGE OF CONCRETE.
- (7) IF NO CURB AND GUTTER IS PLACED IN RURAL SECTIONS, DETECTABLE WARNINGS SHALL BE PLACED 1' FROM THE EDGE OF ROADWAY TO PROVIDE VISUAL CONTRAST.
- (8) ALL CONSTRUCTED CURBS MUST HAVE A CONTINUOUS DETECTABLE EDGE FOR THE VISUALLY IMPAIRED. THIS DETECTABLE EDGE REQUIRES DETECTABLE WARNINGS WHEREVER THERE IS ZERO-INCH HIGH CURB. CURB TAPERS ARE CONSIDERED A DETECTABLE EDGE WHEN THE TAPER STARTS WITHIN 3" OF THE EDGE OF THE DETECTABLE WARNINGS AND UNIFORMLY RISES TO A 3-INCH MINIMUM CURB HEIGHT. ANY CURB NOT PART OF A CURB TAPER AND LESS THAN 3 INCHES IN HEIGHT IS NOT CONSIDERED A DETECTABLE EDGE AND THEREFORE IS NOT COMPLIANT WITH ACCESSIBILITY STANDARDS.

USER NAME: \$\$\$USER\$\$\$
PATH & FILENAME: \$\$\$PATH/FILENAME\$\$\$

FILE NAME:
@FILENAME@

STANDARD PLAN SHEET NO.
5-297.250 (4 OF 5)
STANDARD APPROVED:
APRIL 10, 2013

PEDESTRIAN CURB RAMP DETAILS

STATE PROJ. NO. 002-621-010

SHEET NO. 24 OF 147 SHEETS

PLOTTED/REVISED:
 \$\$\$@DATE@\$\$\$

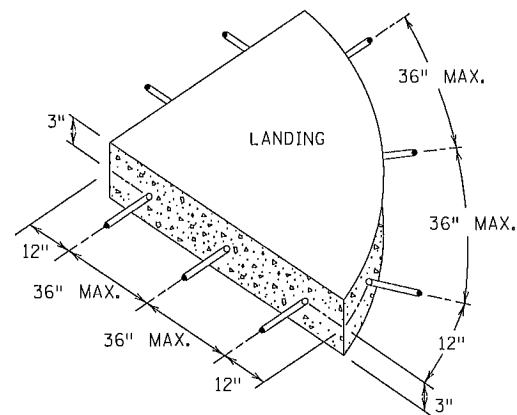
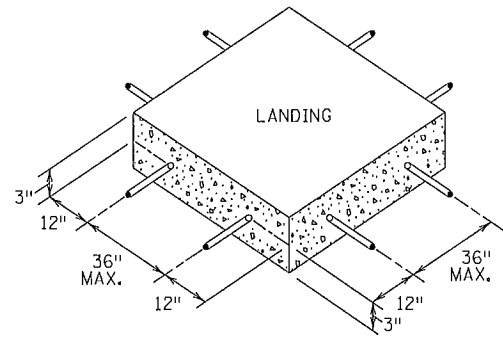

SIDEWALK REINFORCEMENT ⑤ ⑥

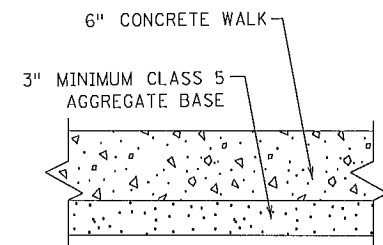

TYPICAL SIDEWALK SECTION WITHIN INTERSECTION CORNER

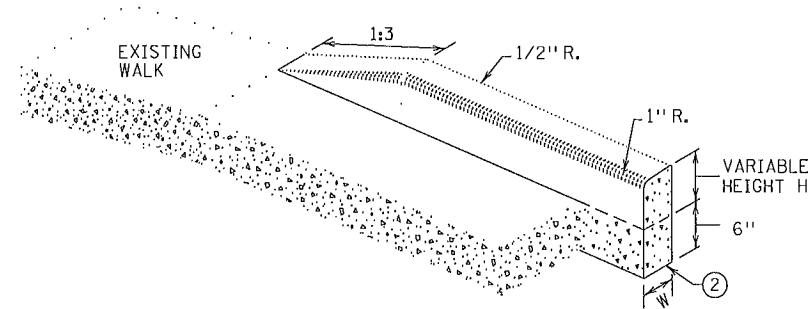

V CURB ADJACENT TO LANDSCAPE
 CURB WITHIN SIDEWALK LIMITS

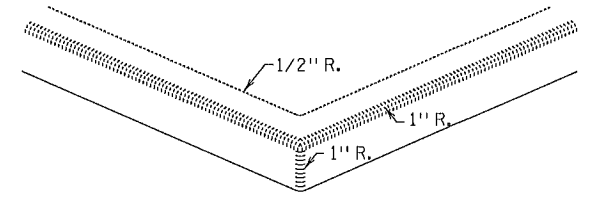

V CURB INTERSECTION

CONCRETE CURB DESIGN V	
CURB HEIGHT H	CURB WIDTH W
< 6"	4"
≥ 6"	6"

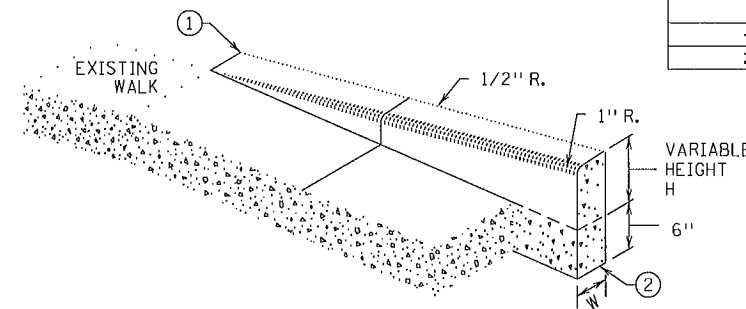

V CURB ADJACENT TO LANDSCAPE
 CURB OUTSIDE SIDEWALK LIMITS

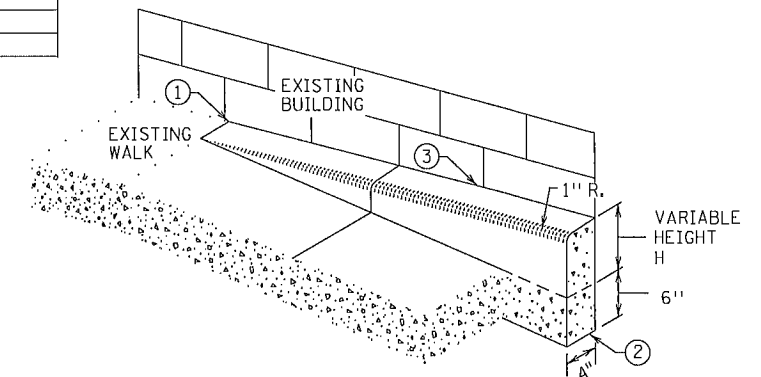

V CURB ADJACENT TO BUILDING
 OR BARRIER

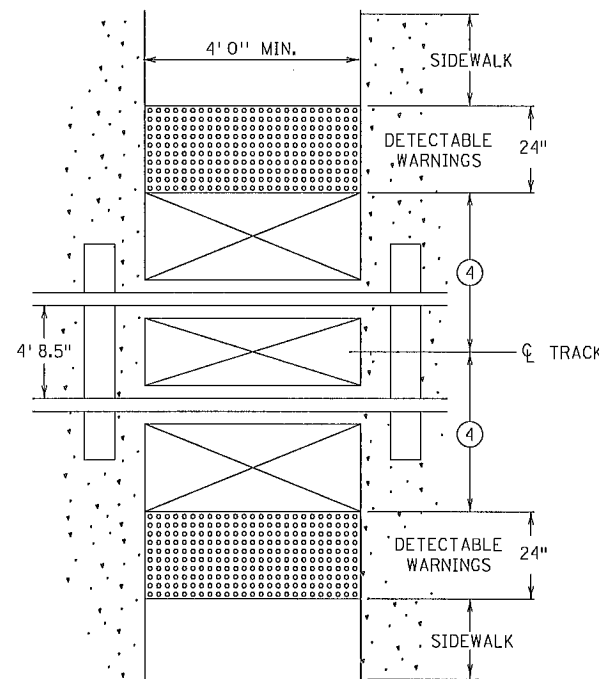

RAILROAD CROSSING
 PLAN VIEW

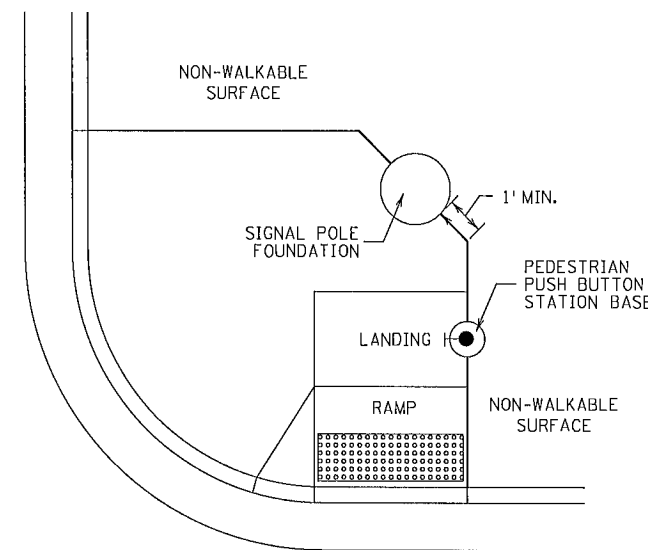

CONCRETE WALK EDGES ADJACENT
 TO CONCRETE STRUCTURES

NOTES:

- ALL V CURB CONTRACTION JOINTS SHALL MATCH CONCRETE WALK JOINTS.
- WHERE RIGHT-OF-WAY ALLOWS, USE OF V CURB SHOULD BE MINIMIZED. GRADING ADJACENT TURF OR SLOPING ADJACENT PAVEMENT IS PREFERRED.
- V CURB SHALL BE PLACED OUTSIDE THE SIDEWALK LIMITS WHEN RIGHT OF WAY ALLOWS.
- V CURB NEXT TO BUILDING SHALL BE A 4" WIDTH AND SHALL MATCH PREVIOUS TOP OF SIDEWALK ELEVATIONS.
- ① END TAPERS AT TRANSITION SECTION SHALL MATCH INPLACE SIDEWALK GRADES.
- ② ALL V CURB SHALL MATCH BOTTOM OF ADJACENT WALK.
- ③ EDGE BETWEEN NEW V CURB AND INPLACE STRUCTURE SHALL BE SEALED AND BOND BREAKER SHALL BE USED BETWEEN EXISTING STRUCTURE AND PLACED V-CURB.
- ④ EDGE OF DETECTABLE WARNING SURFACES SHALL BE PLACED 15' MAXIMUM FROM THE CENTERLINE OF THE TRACK. WHEN PEDESTRIAN GATES ARE PROVIDED, DETECTABLE WARNING SURFACES SHALL BE PLACED ON THE SIDE OF THE GATES OPPOSITE THE RAIL, 17" - 19" FROM THE APPROACHING SIDE OF THE GATE ARM.
- ⑤ WHEN PLAN SPECIFIES, DRILL AND GROUT NO. 4 12" LONG REINFORCEMENT BARS AT 36" MAX. CENTER TO CENTER (EPOXY COATED).
- ⑥ TO ENSURE RAMP AND LANDINGS ARE PROPERLY CONSTRUCTED, LANDINGS MAY BE CAST SEPARATELY. FOLLOW SIDEWALK REINFORCEMENT DETAILS ON THIS SHEET WHEN LANDINGS ARE CAST SEPARATELY.

USER NAME: \$\$\$@USER\$NAME\$\$\$
 PATH & FILENAME: \$\$\$@PATH\$FILENAME\$\$\$

FILE NAME:
 @FILENAME@

STANDARD PLAN SHEET NO.
 5-297.250 (5 OF 5)
 STANDARD APPROVED:
 APRIL 10, 2013

PEDESTRIAN CURB RAMP DETAILS

STATE PROJ. NO. 002-621-010

SHEET NO. 25 OF 147 SHEETS

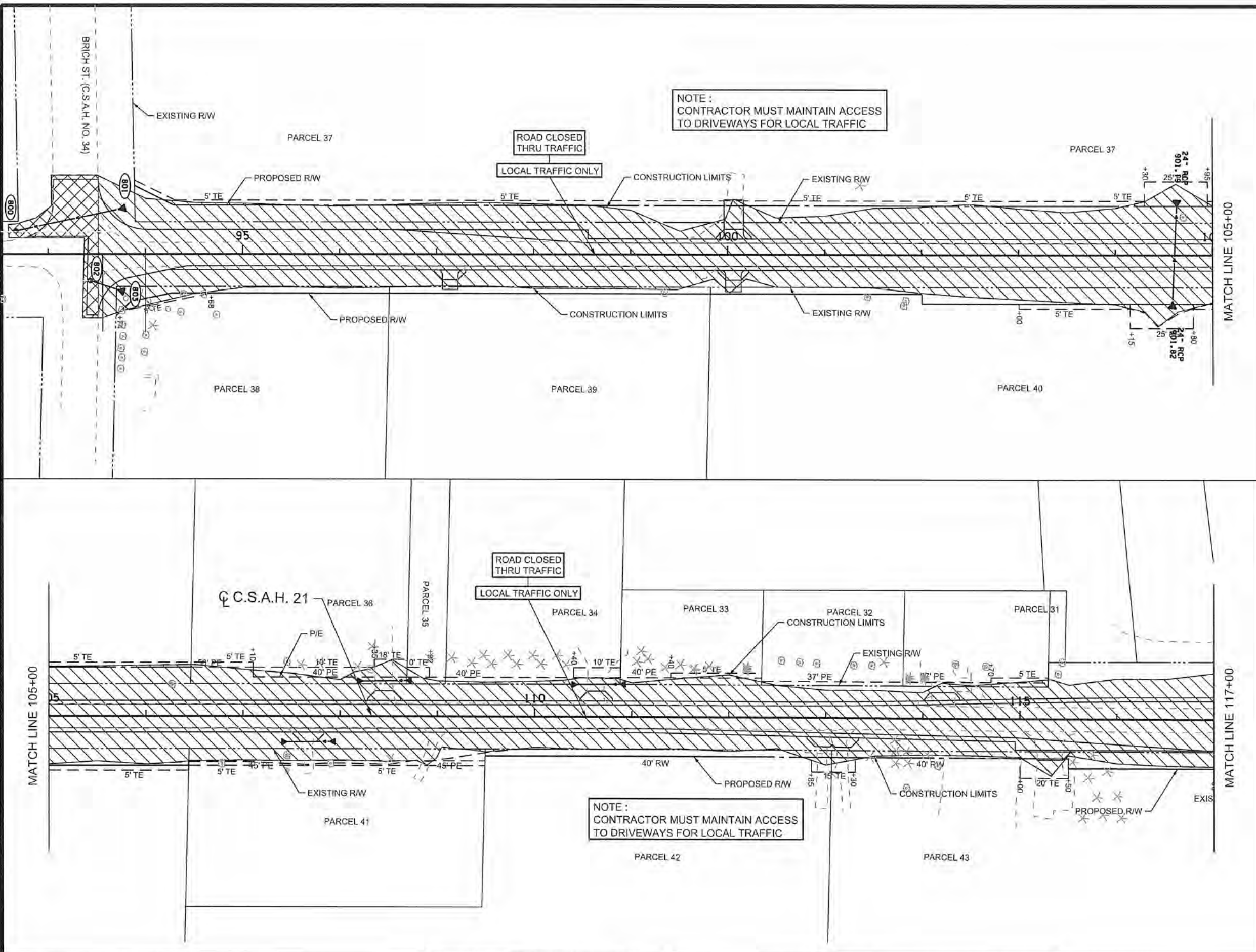

LEGEND

- WORK AREA
- WORK AREA UNDER TRAFFIC
- DRAINAGE TO BE COMPLETED DURING CURRENT STAGE
- INPLACE DRAINAGE PIPES

STAGE 1 CONSTRUCTION NOTES:
 CSAH 21 BETWEEN CSAH 34 AND DUPRE ROAD: 5" AGG OVER SURFACE, BITUMINOUS RECLAMATION, SHOULDER WIDENING FOR NORTH AND SOUTH BOUND, CULVERTS, AND STORM SEWER.

STAGE 1 TRAFFIC NOTES:
 CSAH 21 CLOSED TO THRU TRAFFIC BETWEEN CSAH 34 AND DUPRE ROAD. (DETOUR 1 IN PLACE)

ACCESS SHALL BE MAINTAINED TO ALL DRIVEWAYS IN THE CONSTRUCTION AREA.

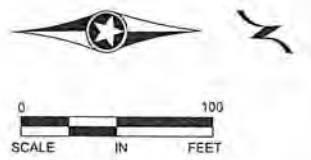

NO	DATE	BY	CKD	APPR	REVISION

NAME: P:\02-621-10\Plan\0262110_STG-1A.dgn 07/11/2014 1:37:49 PM

I HEREBY CERTIFY THAT THIS PLAN WAS PREPARED BY ME OR UNDER MY DIRECT SUPERVISION AND THAT I AM A DULY LICENSED PROFESSIONAL ENGINEER UNDER THE LAWS OF THE STATE OF MINNESOTA.
 PRINT NAME: CURT A. KOBILARCSIK
 SIGNATURE: *[Signature]*
 DATE: 7-14-14 LICENSE NO. 24756

DRAWN BY: ZB DATE: 07-07-14
 DESIGN BY: MN DATE: 07-07-14
 CHECKED BY: CAK DATE: 07-11-14

**ANOKA COUNTY
 HIGHWAY DEPT.**



S.A.P. 002-621-010

**STAGING PLAN
 STAGE 1**

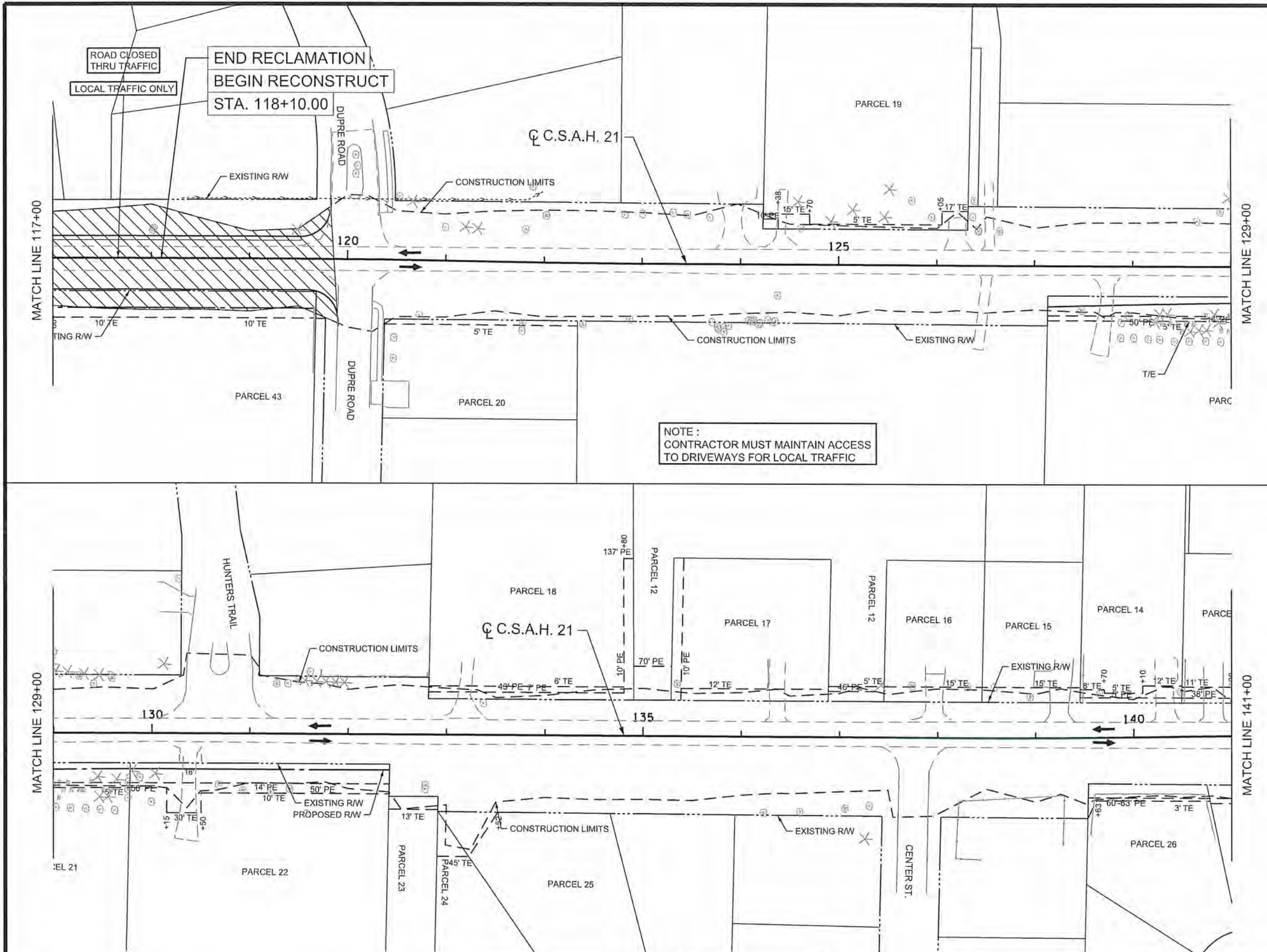
Sheet 26 of 147 Sheets



LEGEND

-  WORK AREA
-  WORK AREA UNDER TRAFFIC
-  TRAFFIC FLOW DIRECTION

NOTE :
CONTRACTOR MUST MAINTAIN ACCESS TO DRIVEWAYS FOR LOCAL TRAFFIC

STAGE 1 CONSTRUCTION NOTES:
CSAH 21 BETWEEN CSAH 34 AND DUPRE ROAD: BITUMINOUS RECLAMATION, FULL RECONSTRUCTION, CONSTRUCTION OF CURB & GUTTER, CULVERTS, AND STORM SEWER SYSTEM. (CONTRACTOR MUST MAINTAIN ACCESS TO LOCAL TRAFFIC)

STAGE 1 TRAFFIC NOTES:
CSAH 21 CLOSED TO THRU TRAFFIC BETWEEN CSAH 34 AND DUPRE ROAD. (DETOUR 1 IN PLACE)

ACCESS SHALL BE MAINTAINED TO ALL DRIVEWAYS IN THE CONSTRUCTION AREA.

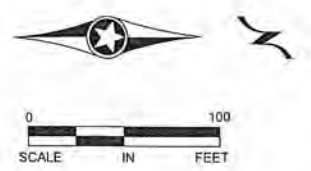

NO	DATE	BY	CKD	APPR	REVISION
NAME: P:\02-621-10\Plan\0262110_STG-1B.dgn					

I HEREBY CERTIFY THAT THIS PLAN WAS PREPARED BY ME OR UNDER MY DIRECT SUPERVISION AND THAT I AM A DULY LICENSED PROFESSIONAL ENGINEER UNDER THE LAWS OF THE STATE OF MINNESOTA.

PRINT NAME: CURT A. KOBILARCSIK
SIGNATURE: *Curt A. Kobilarsik*
DATE: 7-14-14 LICENSE NO. 24755

DRAWN BY: ZB DATE: 07-07-14
DESIGN BY: MN DATE: 07-07-14
CHECKED BY: CAK DATE: 07-11-14

ANOKA COUNTY HIGHWAY DEPT.



S.A.P. 002-621-010

STAGING PLAN STAGE 1

Sheet 27 of 147 Sheets

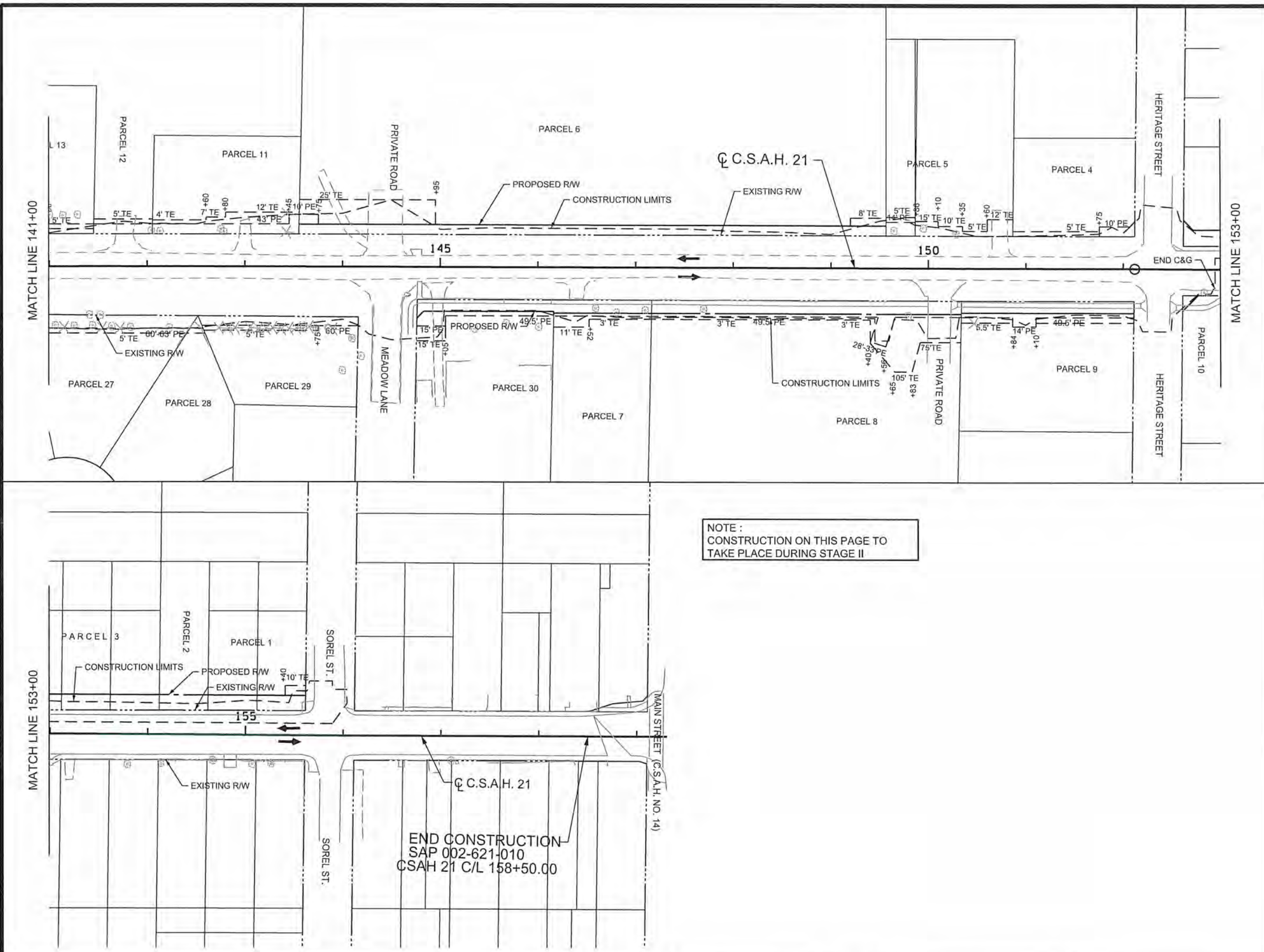

LEGEND

← → TRAFFIC FLOW DIRECTION

NOTE :
CONSTRUCTION ON THIS PAGE TO
TAKE PLACE DURING STAGE II

STAGE 1 CONSTRUCTION NOTES:
CSAH 21 BETWEEN CSAH 34 AND DUPRE ROAD: BITUMINOUS RECLAMATION, FULL RECONSTRUCTION, CONSTRUCTION OF CURB & GUTTER, CULVERTS, AND STORM SEWER SYSTEM. (CONTRACTOR MUST MAINTAIN ACCESS TO LOCAL TRAFFIC)

STAGE 1 TRAFFIC NOTES:
CSAH 21 CLOSED TO THRU TRAFFIC BETWEEN CSAH 34 AND DUPRE ROAD. (DETOUR 1 IN PLACE)

ACCESS SHALL BE MAINTAINED TO ALL DRIVEWAYS IN THE CONSTRUCTION AREA.

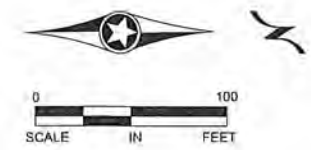

END CONSTRUCTION
SAP 002-621-010
CSAH 21 C/L 158+50.00

NO	DATE	BY	CKD	APPR	REVISION

NAME: P:\02-621-10\Plan\0262110_STG-1C.dgn 07/11/2014 1:37:53 PM

I HEREBY CERTIFY THAT THIS PLAN WAS PREPARED BY ME OR UNDER MY DIRECT SUPERVISION AND THAT I AM A DULY LICENSED PROFESSIONAL ENGINEER UNDER THE LAWS OF THE STATE OF MINNESOTA.

PRINT NAME: CURT A. KOBILARCSIK
SIGNATURE: *[Signature]*
DATE: 7-14-14 LICENSE NO. 24756

DRAWN BY ZB DATE 07-07-14
DESIGN BY MN DATE 07-07-14
CHECKED BY CAK DATE 07-11-14



ANOKA COUNTY
HIGHWAY DEPT.

S.A.P. 002-621-010

STAGING PLAN
STAGE 1
Sheet 28 of 147 Sheets

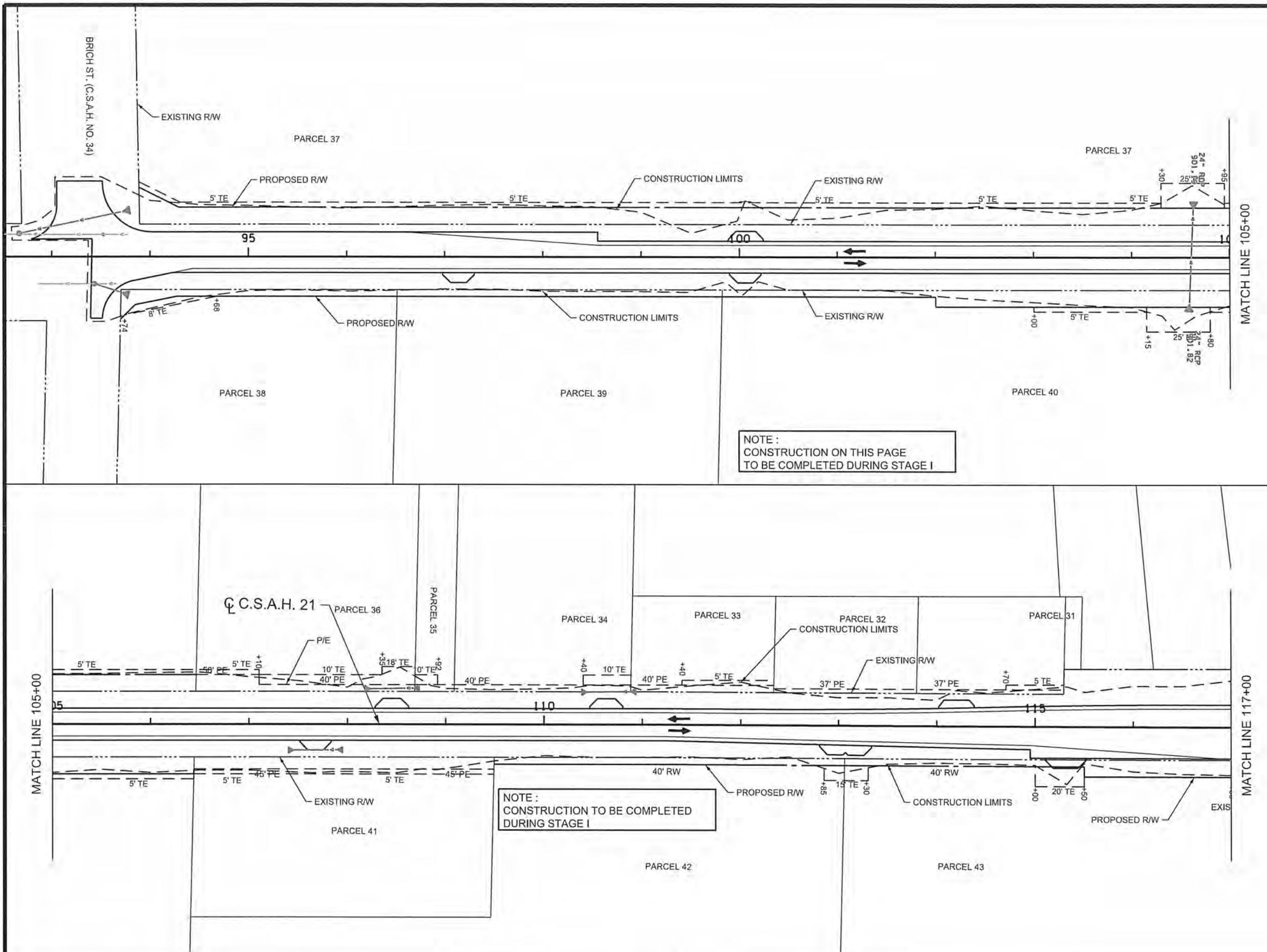

LEGEND

TRAFFIC FLOW DIRECTION
 INPLACE DRAINAGE PIPES

NOTE:
CONSTRUCTION ON THIS PAGE
TO BE COMPLETED DURING STAGE I

NOTE:
CONSTRUCTION TO BE COMPLETED
DURING STAGE I

STAGE 2 CONSTRUCTION NOTES:

CSAH 21 BETWEEN DUPRE ROAD AND SOREL ST. : FULL RECONSTRUCTION, CONSTRUCT CURB & GUTTER, CULVERTS, STORM SEWER SYSTEM, MILL & OVERLAY (CONTRACTOR MUST MAINTAIN ACCESS TO LOCAL TRAFFIC)

STAGE 2 TRAFFIC NOTES:

CSAH 21 CLOSED TO THRU TRAFFIC BETWEEN DUPRE ROAD AND SOREL ST. (DETOUR 2 IN PLACE)

ACCESS SHALL BE MAINTAINED TO ALL DRIVEWAYS IN THE CONSTRUCTION AREA.

TRAFFIC SHIFTED TO THE SOUTH OF DUPRE ROAD.

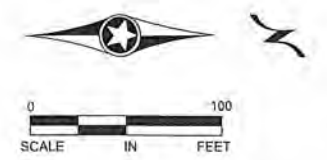

NO	DATE	BY	CKD	APPR	REVISION
NAME: P:\02-621-10\Plan\0262110_STG-2A.dgn					

I HEREBY CERTIFY THAT THIS PLAN WAS PREPARED BY ME OR UNDER MY DIRECT SUPERVISION AND THAT I AM A DULY LICENSED PROFESSIONAL ENGINEER UNDER THE LAWS OF THE STATE OF MINNESOTA.

PRINT NAME: CURT A. KOBILARCSIK
 SIGNATURE: *Curt A. Kobilarsik*
 DATE: 7-14-14 LICENSE NO. 24756

DRAWN BY: ZB DATE: 07-07-14
 DESIGN BY: MN DATE: 07-07-14
 CHECKED BY: CAK DATE: 07-11-14

ANOKA COUNTY
HIGHWAY DEPT.

S.A.P. 002-621-010

STAGING PLAN
STAGE 2

Sheet 29 of 147 Sheets

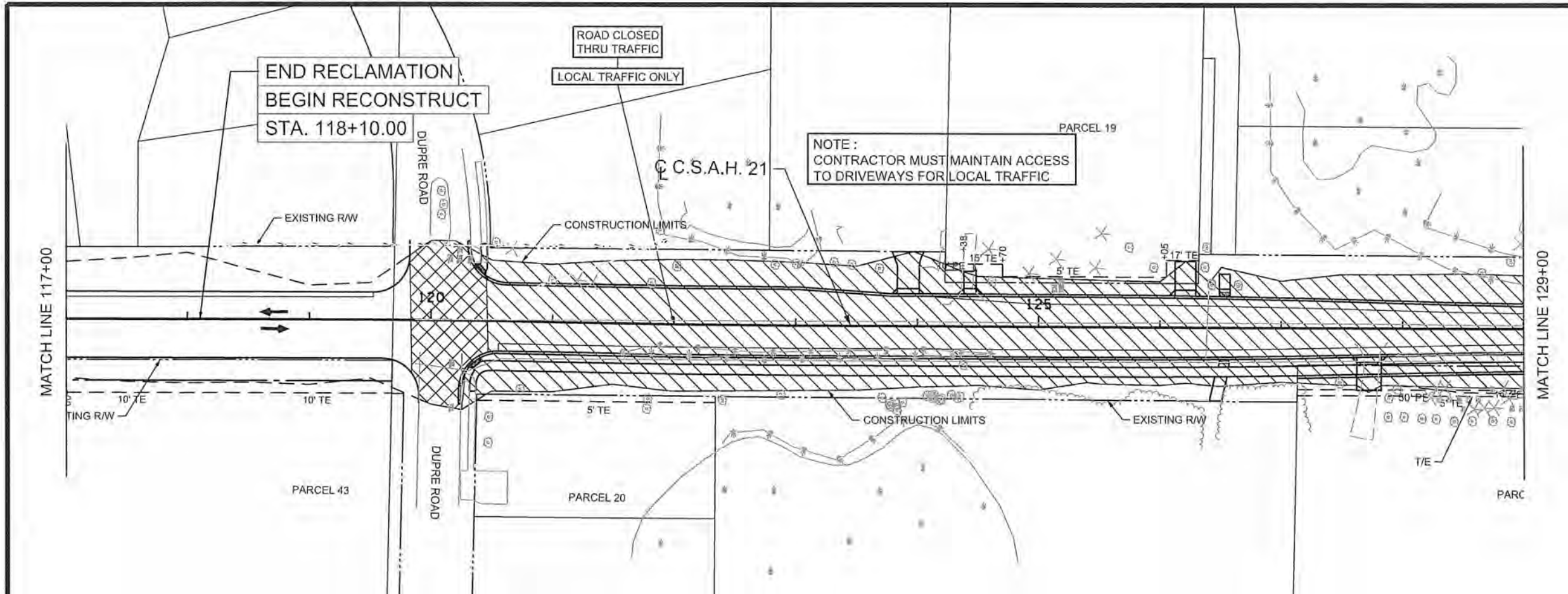

LEGEND

- WORK AREA
- WORK AREA UNDER TRAFFIC
- TRAFFIC FLOW DIRECTION
- DRAINAGE TO BE COMPLETED DURING CURRENT STAGE

STAGE 2 CONSTRUCTION NOTES:
 CSAH 21 BETWEEN DUPRE ROAD AND SOREL ST. : FULL RECONSTRUCTION, CONSTRUCT CURB & GUTTER, CULVERTS, STORM SEWER SYSTEM, MILL & OVERLAY (CONTRACTOR MUST MAINTAIN ACCESS TO LOCAL TRAFFIC)

STAGE 2 TRAFFIC NOTES:
 CSAH 21 CLOSED TO THRU TRAFFIC BETWEEN DUPRE ROAD AND SOREL ST. (DETOUR 1 IN PLACE)
 ACCESS SHALL BE MAINTAINED TO ALL DRIVEWAYS IN THE CONSTRUCTION AREA.

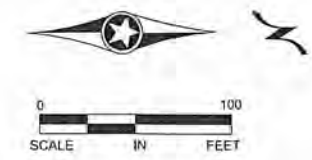
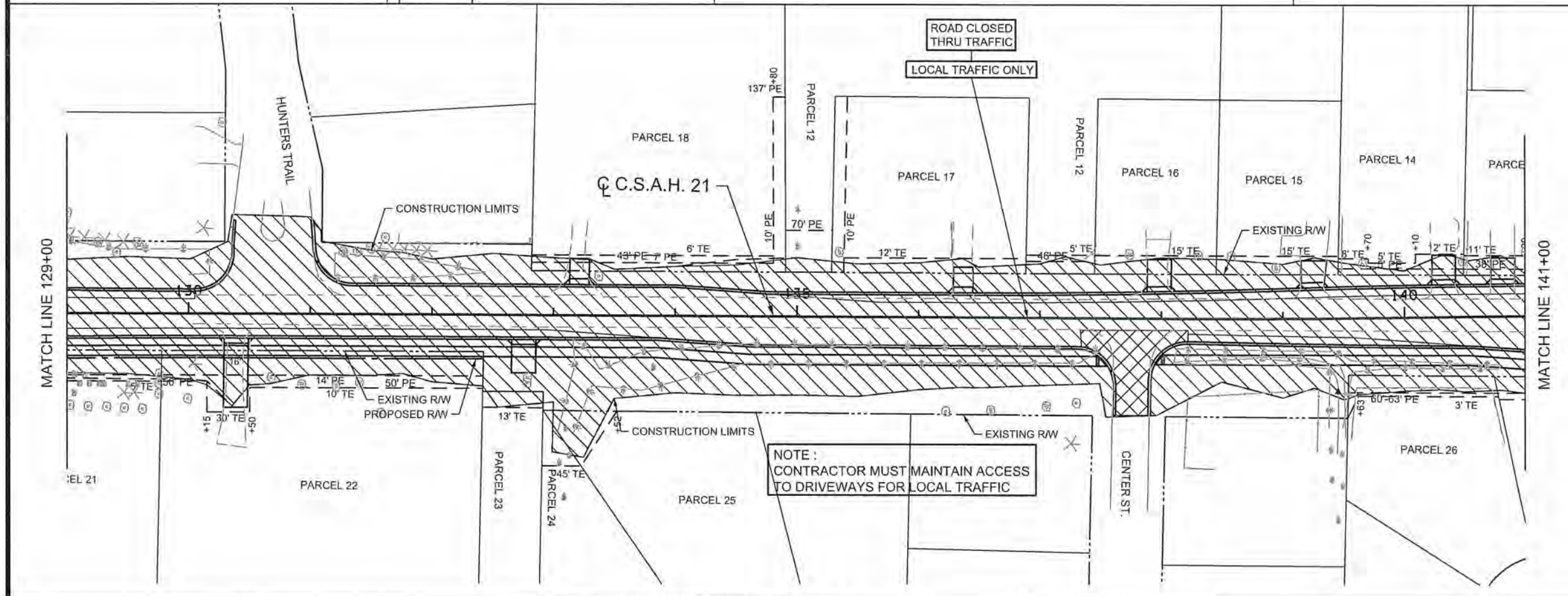

NO	DATE	BY	CKD	APPR	REVISION

NAME: P:\02-621-10\Plan\0262110_STG-2B.dgn 07/11/2014 1:37:57 PM

I HEREBY CERTIFY THAT THIS PLAN WAS PREPARED BY ME OR UNDER MY DIRECT SUPERVISION AND THAT I AM A DULY LICENSED PROFESSIONAL ENGINEER UNDER THE LAWS OF THE STATE OF MINNESOTA.
 PRINT NAME: CURT A. KOBIARCSIK
 SIGNATURE: *Curt A. Kobiarcsik*
 DATE: 7-14-14 LICENSE NO. 24756

DRAWN BY: ZB DATE: 07-07-14
 DESIGN BY: MN DATE: 07-07-14
 CHECKED BY: CAR DATE: 07-11-14

ANOKA COUNTY HIGHWAY DEPT.



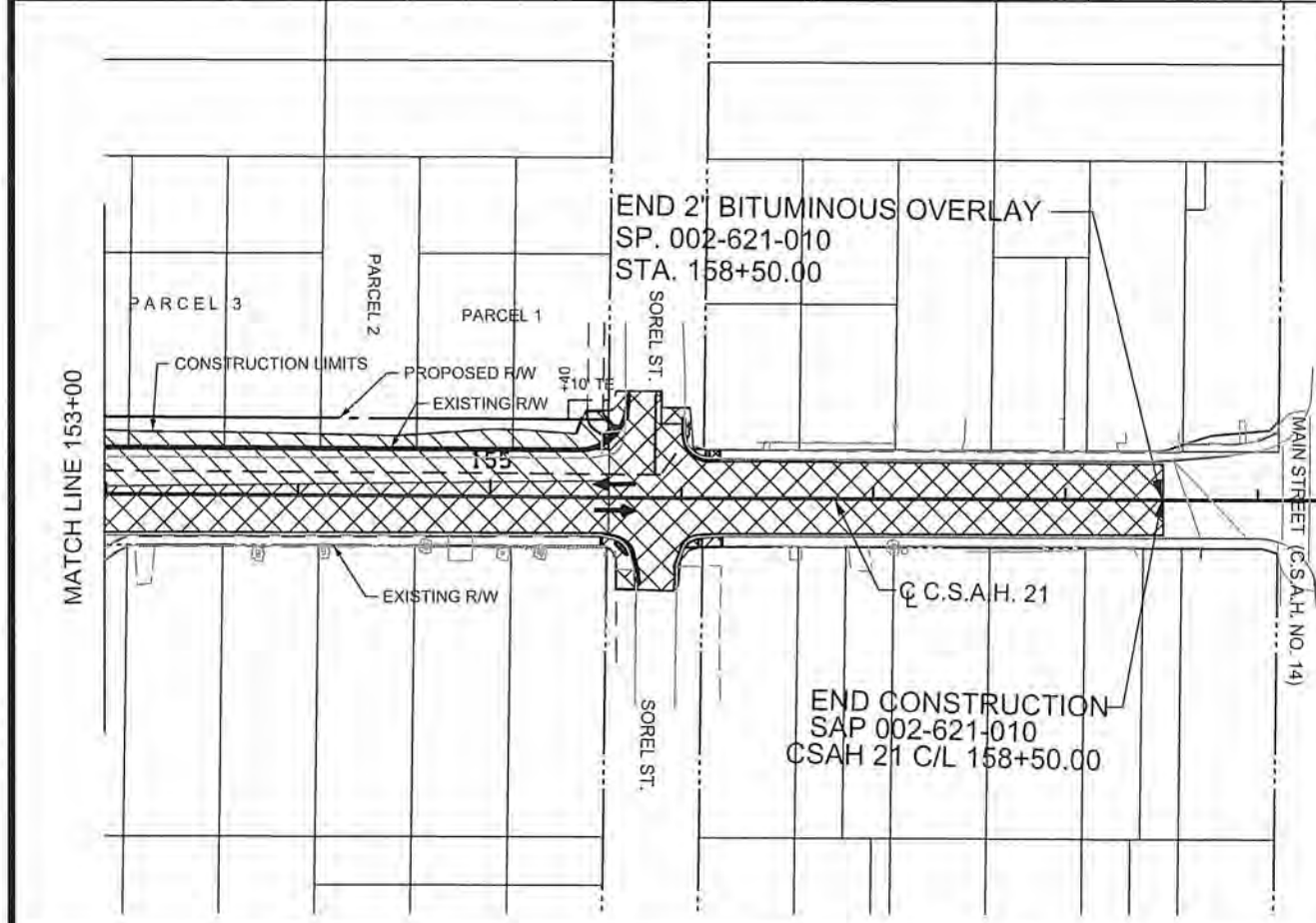
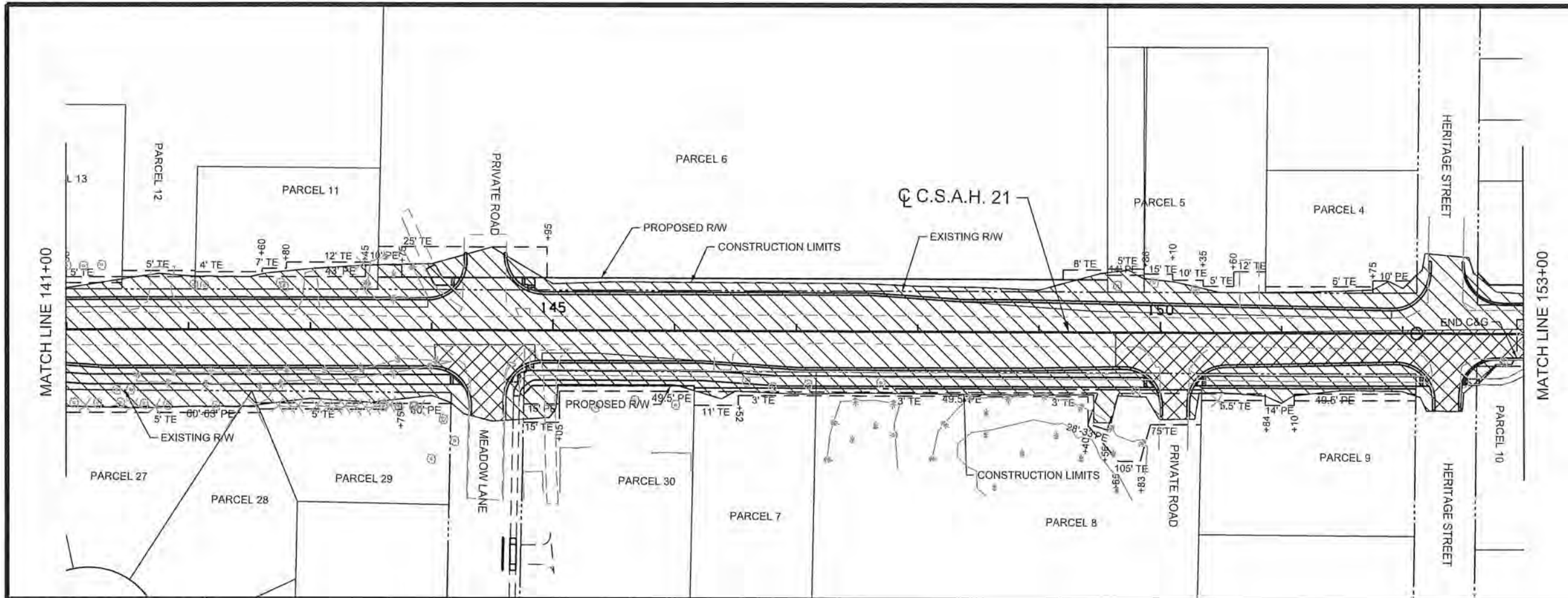

S.A.P. 002-621-010

STAGING PLAN STAGE 2
 Sheet 30 of 147 Sheets



NOTE:
CONTRACTOR MUST MAINTAIN ACCESS
TO DRIVEWAYS FOR LOCAL TRAFFIC

LEGEND

-  WORK AREA
-  WORK AREA UNDER TRAFFIC
-  TRAFFIC FLOW DIRECTION
-  DRAINAGE TO BE COMPLETED DURING CURRENT STAGE

STAGE 2 CONSTRUCTION NOTES:
CSAH 21 BETWEEN DUPRE ROAD AND SOREL ST. : FULL RECONSTRUCTION, CONSTRUCT CURB & GUTTER, CULVERTS, STORM SEWER SYSTEM, MILL & OVERLAY (CONTRACTOR MUST MAINTAIN ACCESS TO LOCAL TRAFFIC)

STAGE 2 TRAFFIC NOTES:
CSAH 21 CLOSED TO THRU TRAFFIC BETWEEN DUPRE ROAD AND SOREL ST. (DETOUR 2 IN PLACE)

ACCESS SHALL BE MAINTAINED TO ALL DRIVEWAYS IN THE CONSTRUCTION AREA.

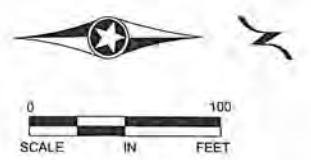

NO	DATE	BY	CKD	APPR	REVISION

NAME: P:\02-621-10\Plan\0262110_STG-2C.dgn 07/11/2014 1:37:59 PM

I HEREBY CERTIFY THAT THIS PLAN WAS PREPARED BY ME OR UNDER MY DIRECT SUPERVISION AND THAT I AM A DULY LICENSED PROFESSIONAL ENGINEER UNDER THE LAWS OF THE STATE OF MINNESOTA.
 PRINT NAME: CURT A. KOBILARCSIK
 SIGNATURE: *Curt Kobilarsik*
 DATE: 7-11-14 LICENSE NO. 24758

DRAWN BY: ZB DATE: 07-07-14
 DESIGN BY: MN DATE: 07-07-14
 CHECKED BY: CAK DATE: 07-11-14

ANOKA COUNTY HIGHWAY DEPT.



S.A.P. 002-621-010

STAGING PLAN
STAGE 2
Sheet 31 of 147 Sheets

ALIGNMENT TABULATION

POINT NUMBER	POINT	ALIGNMENT	CIRCULAR CURVE DATA					COORDINATES		AZIMUTH	
			DELTA	DEGREE	RADIUS	TANGENT	LENGTH	E	N		
☉ C.S.A.H. 21 <N21>											
1049	POT	☉ C.S.A.H. 21	85+00.000					554,364.9271	139,560.9186		
1050	POT		93+61.594					554,352.7549	140,422.4263		
1051	POT		110+96.983					554,329.9720	142,157.6657		
	PC		119+51.631					554,322.0312	143,012.2771	N 0° 31' 56.49" W	
CL .21-1	PI		120+36.261	1° 00' 56.05" RT	0° 36' 00.07"	9,549.000'	84.630'	169.256'	554,321.2449	143,096.9039	PI
	CC							563,870.6190	143,100.9994		
	PRC		121+20.887					554,321.9586	143,181.5313	N 0° 28' 59.56" E	
	PRC		121+20.887					554,321.9586	143,181.5313	N 0° 28' 59.56" E	
CL .21-2	PI		122+05.518	1° 00' 56.05" LT	0° 36' 00.07"	9,549.000'	84.630'	169.256'	554,322.6724	143,266.1588	PI
	CC							544,773.2982	143,262.0632		
	PT		122+90.144					554,321.8860	143,350.7856	N 0° 31' 56.49" W	

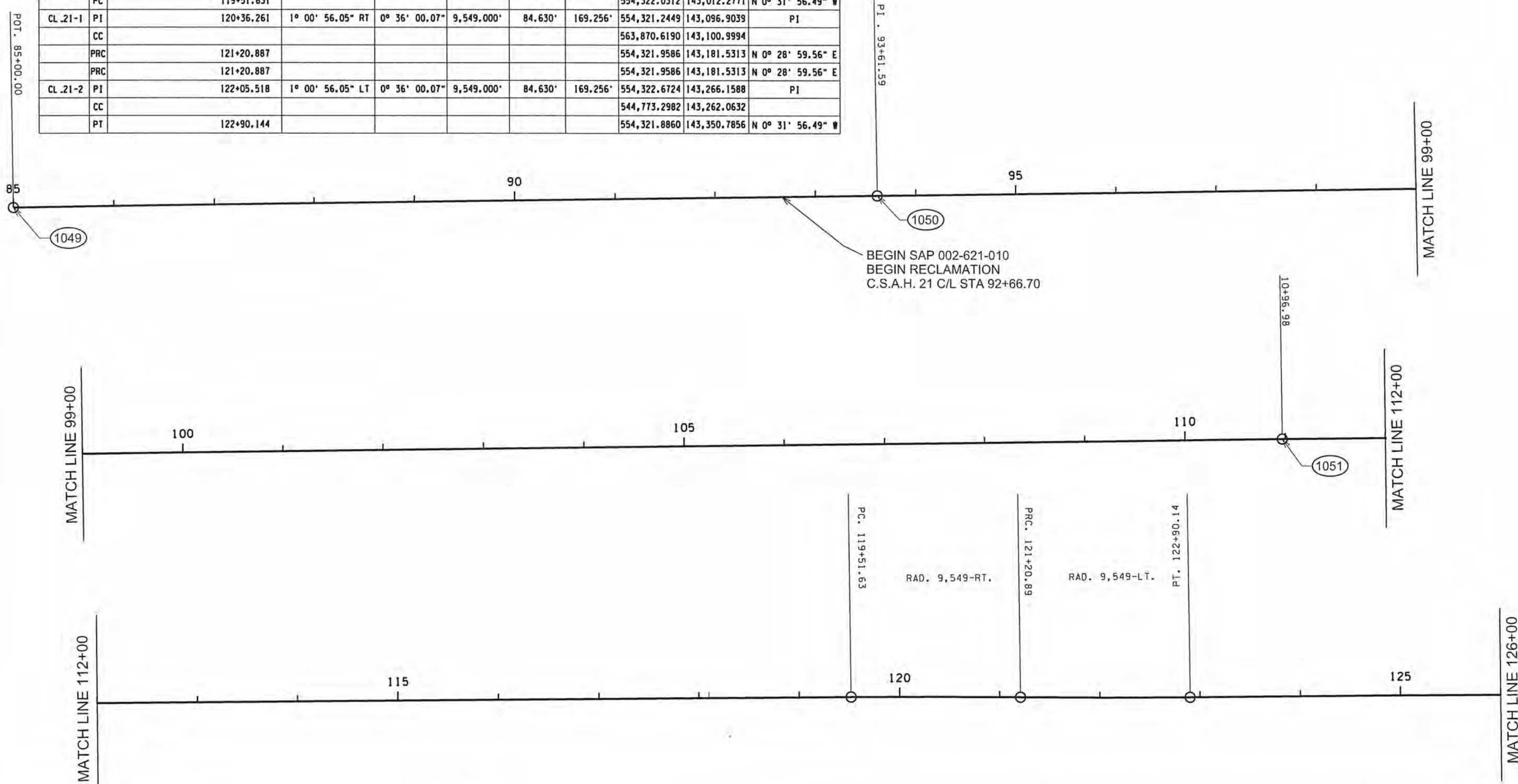
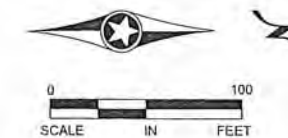

NO	DATE	BY	CKD	APPR	REVISION

I HEREBY CERTIFY THAT THIS PLAN WAS PREPARED BY ME OR UNDER MY DIRECT SUPERVISION AND THAT I AM A DULY LICENSED PROFESSIONAL ENGINEER UNDER THE LAWS OF THE STATE OF MINNESOTA.

PRINT NAME: CURT A. KOBILARCSIK
 SIGNATURE: *Curt Kobilarcsik*
 DATE: 7-14-14 LICENSE NO. 24756

DRAWN BY: ZB DATE 07-07-14
 DESIGN BY: MN DATE 07-07-14
 CHECKED BY: CAK DATE 07-11-14

ANOKA COUNTY

HIGHWAY DEPT.

S.A.P. 002-621-010

CSAH 21 ALIGNMENT PLAN

STA 85+00.00 TO 126+00.00

Sheet 32 of 147 Sheets

ALIGNMENT TABULATION

POINT NUMBER	POINT	ALIGNMENT	CIRCULAR CURVE DATA					COORDINATES		AZIMUTH	
			DELTA	DEGREE	RADIUS	TANGENT	LENGTH	E	N		
☉ C.S.A.H. 21 <N21>											
	PC	☉ C.S.A.H. 21	138+44.209					554,307.4468	144,904.7836	N 0° 31' 56.49" W	
CL .21-3	PI		139+30.549	1° 17' 42.45" LT	0° 45' 00.15"	7,639.000'	86.340'	172.673'	554,306.6446	144,991.1202	PI
	CC							546,668.7765	144,833.8076		
	PRC		140+16.882					554,303.8912	145,077.4166	N 1° 49' 38.93" W	
	PRC		140+16.882					554,303.8912	145,077.4166	N 1° 49' 38.93" W	
CL .21-4	PI		140+95.518	1° 10' 46.43" RT	0° 45' 00.15"	7,639.000'	78.636'	157.266'	554,301.3835	145,156.0124	PI
	CC							561,939.0058	145,321.0256		
	PT		141+74.148					554,300.4942	145,234.6432	N 0° 38' 52.51" W	
1052	POT		152+11.415					554,288.7648	146,271.8436		
1053	POT		155+95.794					554,286.0912	146,656.2136		
1054	POT	☉ C.S.A.H. 21	159+30.841					554,282.4702	146,991.2406		

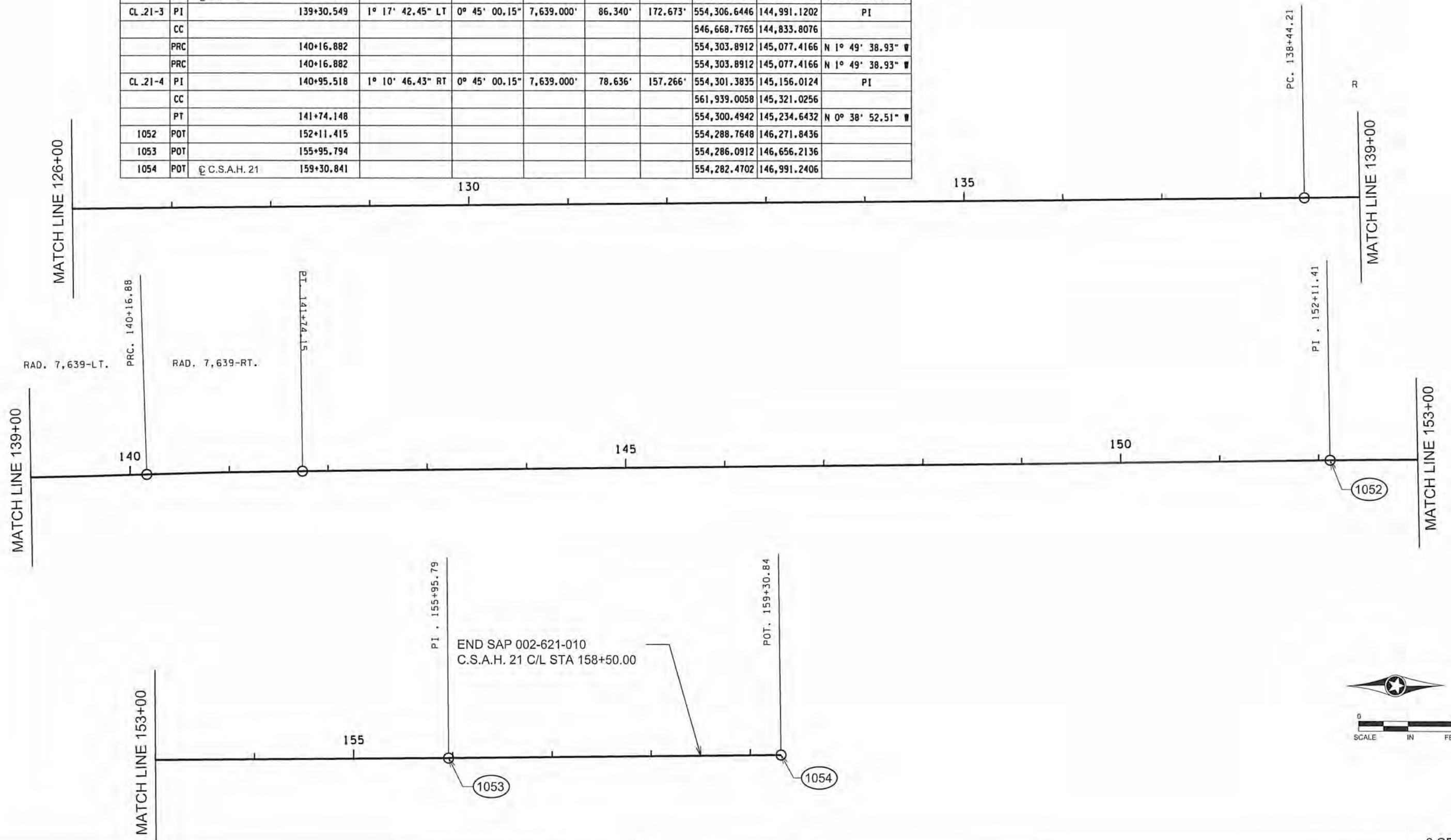

NO	DATE	BY	CKD	APPR	REVISION

I HEREBY CERTIFY THAT THIS PLAN WAS PREPARED BY ME OR UNDER MY DIRECT SUPERVISION AND THAT I AM A DULY LICENSED PROFESSIONAL ENGINEER UNDER THE LAWS OF THE STATE OF MINNESOTA.

PRINT NAME: CURT A. KOBILARCSIK
 SIGNATURE: *Curt A. Kobilarsik*
 DATE: 7-14-14 LICENSE NO. 24756

DRAWN BY: ZB DATE: 07-07-14
 DESIGN BY: MN DATE: 07-07-14
 CHECKED BY: CAK DATE: 07-07-14

ANOKA COUNTY
HIGHWAY DEPT.

S.A.P. 002-621-010

CSAH 21 ALIGNMENT PLAN
 STA 126+00.00 TO 159+30.79
 Sheet 33 of 147 Sheets

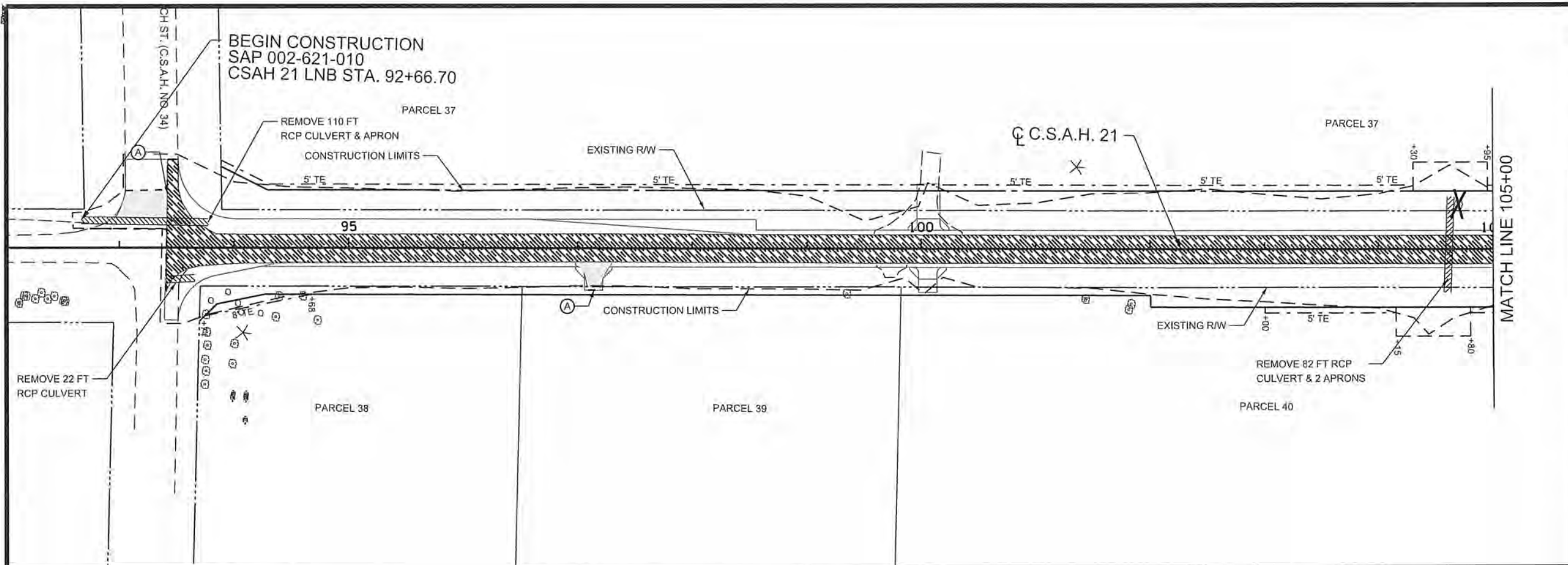

LEGEND

- REMOVE BITUMINOUS PAVEMENT
- RECLAIM AND OVERLAY BITUMINOUS PAVEMENT
- REMOVE CONCRETE PAVEMENT
- CLEAR & GRUB (ACRE)
- REMOVE PIPE CULVERTS
- TREE REMOVAL BY EACH
- REMOVE CURB AND GUTTER
- SAWING BITUMINOUS PAVEMENT
- CONSTRUCTION LIMIT
- TEMPORARY EASEMENT
- PERMANENT EASEMENT
- CLOSE DRIVE ACCESS

NOTES:

- (A) FULL DEPTH SAWCUT
- (B) REMOVE C&G

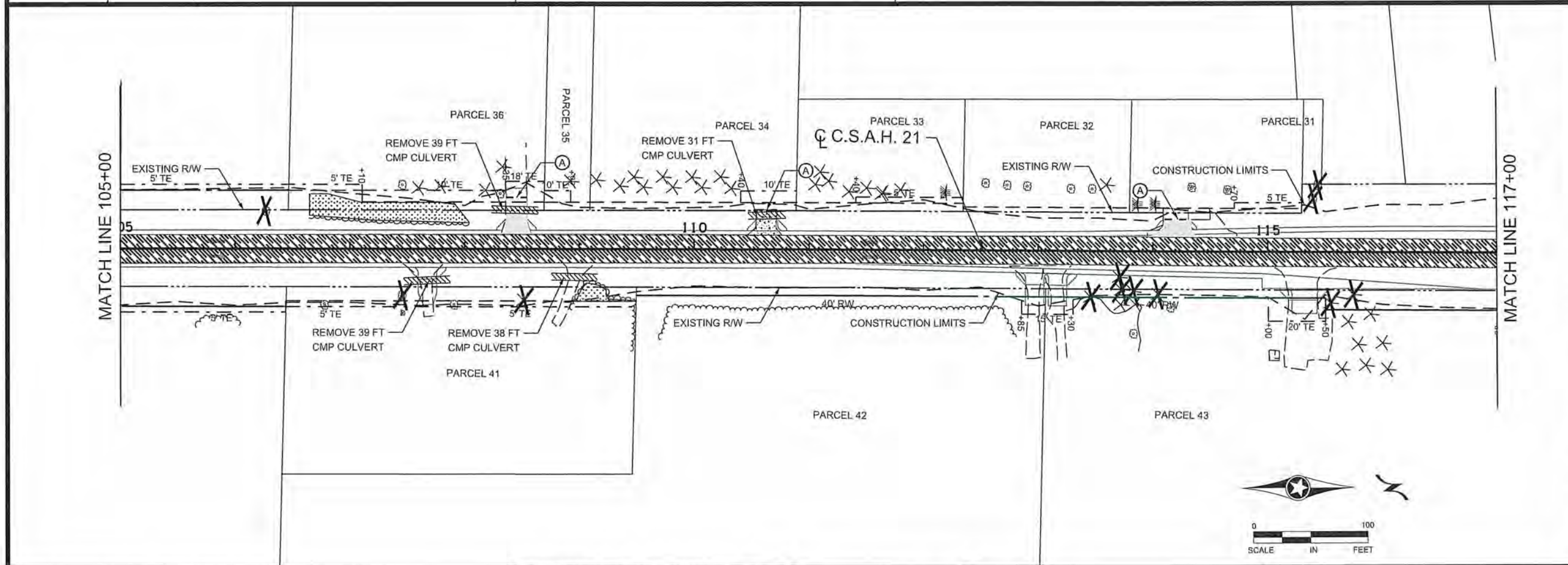

REMOVAL NOTES

THE CONTRACTOR SHALL PERFORM ALL CLEARING AND GRUBBING AS DIRECTED AND MARKED IN THE FIELD BY THE ENGINEER. THE CONTRACTOR SHALL OTHERWISE PROTECT ALL EXISTING TREES NOT SPECIFICALLY MARKED FOR REMOVAL.

ALL MANHOLES AND CATCH BASINS WILL BE PAID FOR AS "REMOVE DRAINAGE "STRUCTURE" ITEM 2104.509 CALLED OUT IN REMOVAL PLANS AS MH AND CB. FOR INFORMATION PURPOSES ONLY.

ALL PRIVATE UTILITIES TO BE RELOCATED BY OTHERS AS REQUIRED. SEE IN PLACE UTILITY TABULATION FOR MORE INFORMATION.

ALL ROADWAY SIGNS WITHIN THE CONSTRUCTION LIMITS AND CONFLICTING SIGNS SHALL BE SALVAGED BY THE CONTRACTOR.

SEE CITY WATERMAIN AND SEWERS PLANS FOR WATERMAIN, HYDRANT, AND SEWER REMOVAL ITEMS.

1 OF 3

01	7-21-14	ZB	MN	MNDOT COMMENTS
NO	DATE	BY	CKD	APPR
NAME: P:\02-621-10\Plan\0262110_REM_1.dgn				

I HEREBY CERTIFY THAT THIS PLAN WAS PREPARED BY ME OR UNDER MY DIRECT SUPERVISION AND THAT I AM A DULY LICENSED PROFESSIONAL ENGINEER UNDER THE LAWS OF THE STATE OF MINNESOTA.

PRINT NAME: CURT A. KOBILARCSIK

SIGNATURE: *[Signature]*

DATE: 7-22-14 LICENSE NO. 24756

DRAWN BY: ZB DATE: 07-07-14

DESIGN BY: MN DATE: 07-07-14

CHECKED BY: CAK DATE: 07-11-14

ANOKA COUNTY
HIGHWAY DEPT.

S.A.P. 002-621-010

SCALE: 0 IN FEET

INPLACE TOPOGRAPHY & REMOVAL PLAN

STA 92+66.70 TO 117+00.00

Sheet 34 of 147 Sheets

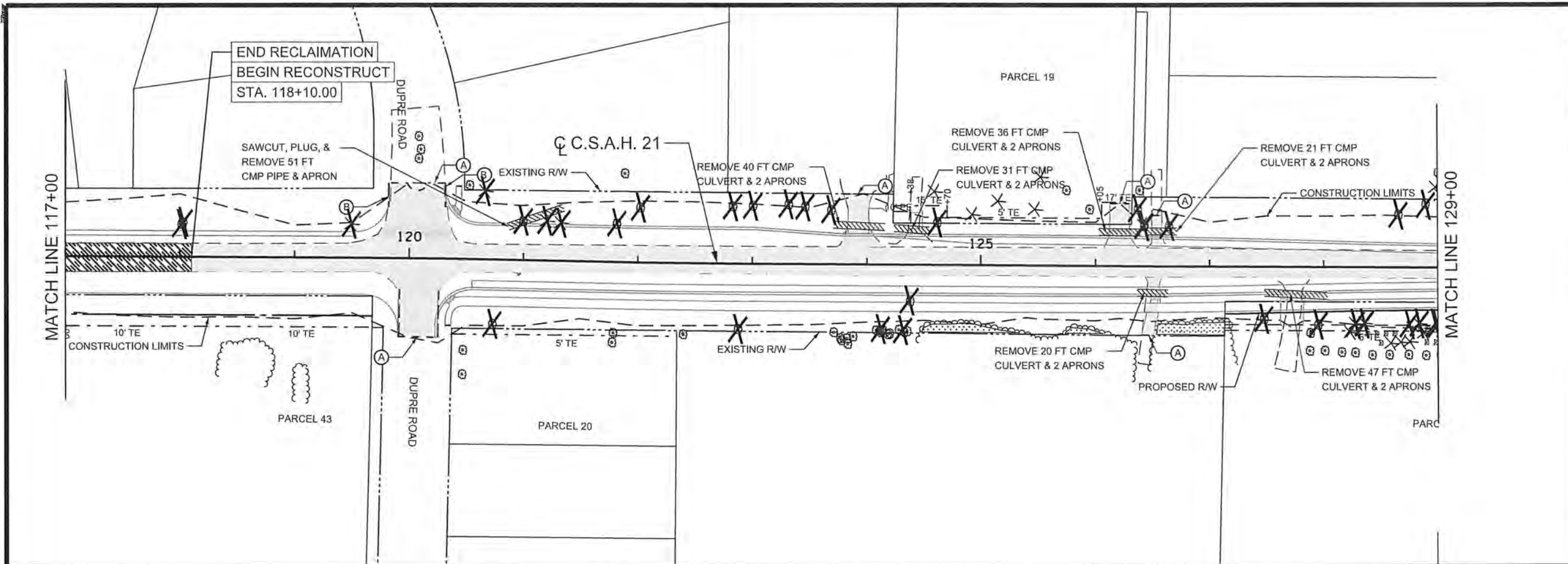

LEGEND

- REMOVE BITUMINOUS PAVEMENT
- RECLAIM BITUMINOUS PAVEMENT
- REMOVE CONCRETE PAVEMENT
- CLEAR & GRUB (ACRE)
- REMOVE PIPE CULVERTS REMOVE STORM SEWER
- TREE REMOVAL BY EACH
- REMOVE CURB AND GUTTER
- SAWING BITUMINOUS PAVEMENT
- CONSTRUCTION LIMIT
- TEMPORARY EASEMENT
- PERMANENT EASEMENT
- CLOSE DRIVE ACCESS

NOTES:

- (A) FULL DEPTH SAWCUT
- (B) REMOVE C&G

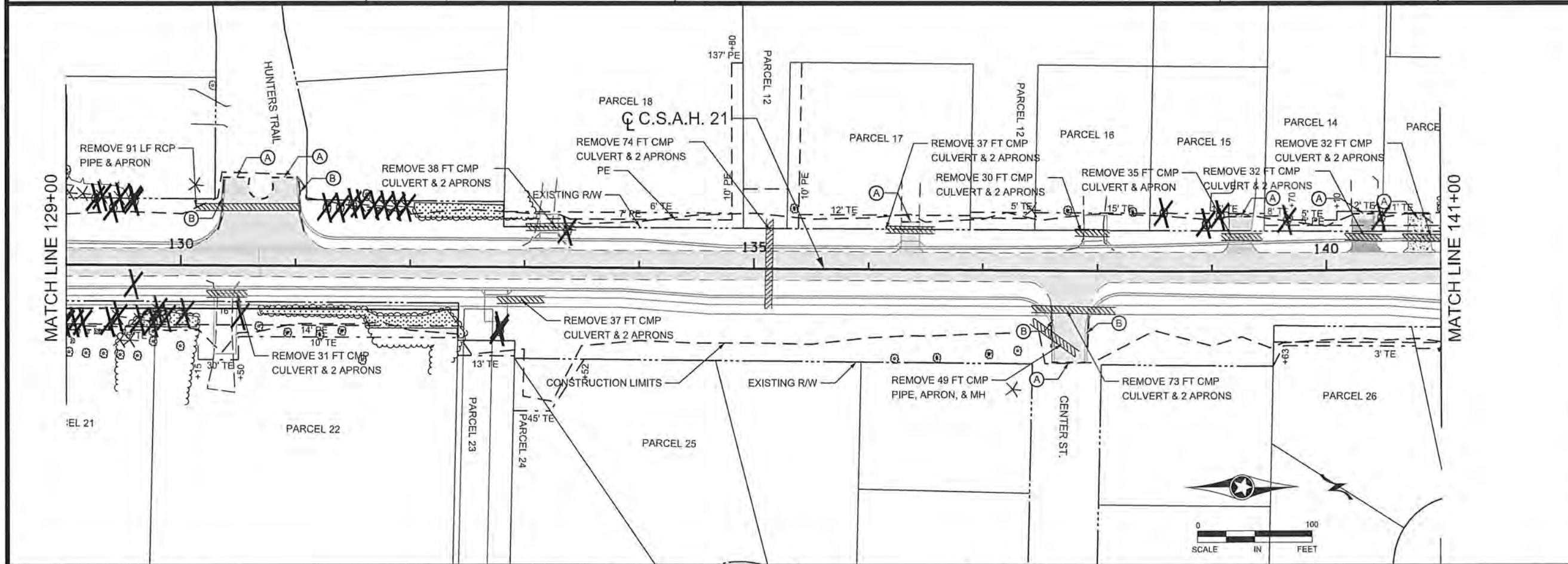

REMOVAL NOTES

THE CONTRACTOR SHALL PERFORM ALL CLEARING AND GRUBBING AS DIRECTED AND MARKED IN THE FIELD BY THE ENGINEER. THE CONTRACTOR SHALL OTHERWISE PROTECT ALL EXISTING TREES NOT SPECIFICALLY MARKED FOR REMOVAL.

ALL MANHOLES AND CATCH BASINS WILL BE PAID FOR AS "REMOVE DRAINAGE "STRUCTURE" ITEM 2104.509 CALLED OUT IN REMOVAL PLANS AS MH AND CB. FOR INFORMATION PURPOSES ONLY.

ALL PRIVATE UTILITIES TO BE RELOCATED BY OTHERS AS REQUIRED. SEE IN PLACE UTILITY TABULATION FOR MORE INFORMATION.

ALL ROADWAY SIGNS WITHIN THE CONSTRUCTION LIMITS AND CONFLICTING SIGNS SHALL BE SALVAGED BY THE CONTRACTOR.

SEE CITY WATERMAIN AND SEWERS PLANS FOR WATERMAIN, HYDRANT, AND SEWER REMOVAL ITEMS.

2 OF 3

01	7-21-14	ZB	MN		MNDOT COMMENTS
NO	DATE	BY	CKD	APPR	REVISION
NAME: P:\02-621-10\Plan\0262110_REM_2.dgn 07/21/2014 10:57:45 AM					

I HEREBY CERTIFY THAT THIS PLAN WAS PREPARED BY ME OR UNDER MY DIRECT SUPERVISION AND THAT I AM A DULY LICENSED PROFESSIONAL ENGINEER UNDER THE LAWS OF THE STATE OF MINNESOTA.

PRINT NAME: CURT A. KOBIARCSIK

SIGNATURE: *Curt A. Kobilarcsik*

DATE: 7-22-14 LICENSE NO. 24755

DRAWN BY: ZB DATE: 07-07-14

DESIGN BY: MN DATE: 07-07-14

CHECKED BY: CAK DATE: 07-11-14

ANOKA COUNTY
HIGHWAY DEPT.

S.A.P. 002-621-010

INPLACE TOPOGRAPHY & REMOVAL PLAN
STA 117+00.00 TO 141+00.00
Sheet 35 of 147 Sheets

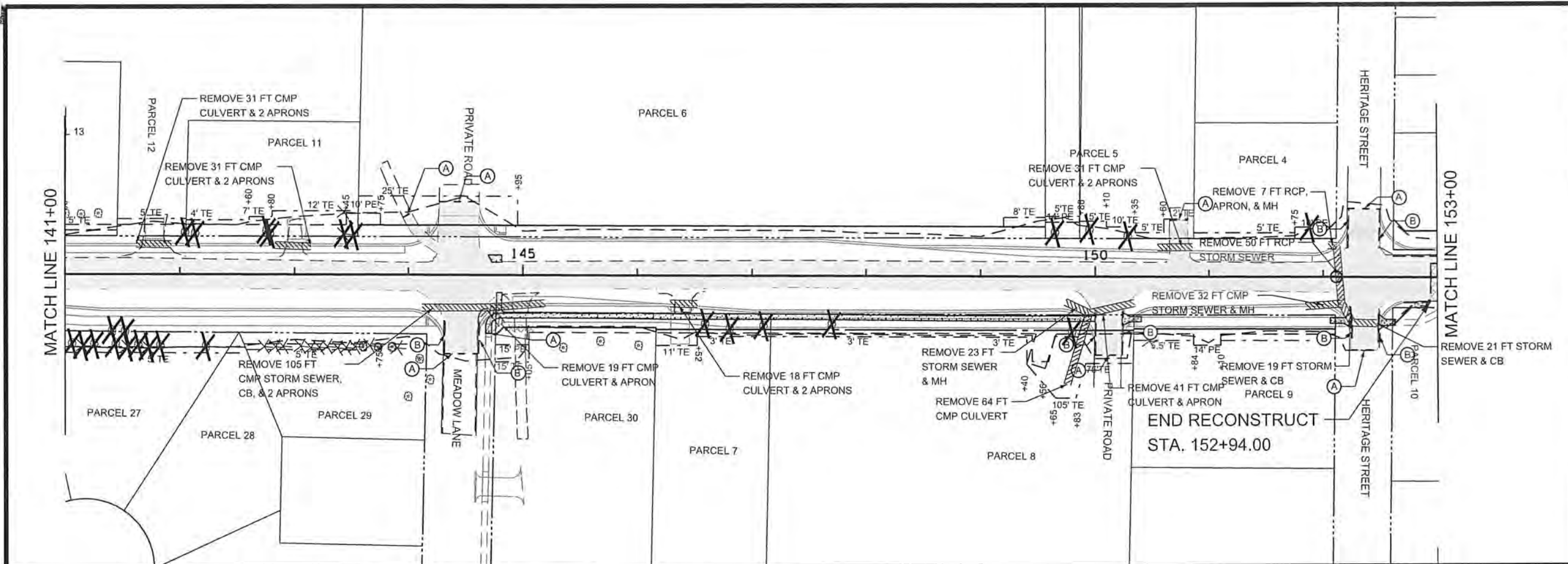

LEGEND

- REMOVE BITUMINOUS PAVEMENT
- REMOVE CONCRETE PAVEMENT
- MILL AND OVERLAY BITUMINOUS PAVEMENT
- RECLAIM & OVERLAY BITUMINOUS PAVEMENT
- REMOVE PIPE CULVERTS REMOVE STORM SEWER
- TREE REMOVAL BY EACH
- REMOVE CURB AND GUTTER
- SAWING BITUMINOUS PAVEMENT
- CONSTRUCTION LIMIT
- TEMPORARY EASEMENT
- PERMANENT EASEMENT
- CLOSE DRIVE ACCESS

NOTES:

- (A) FULL DEPTH SAWCUT
- (B) REMOVE C&G

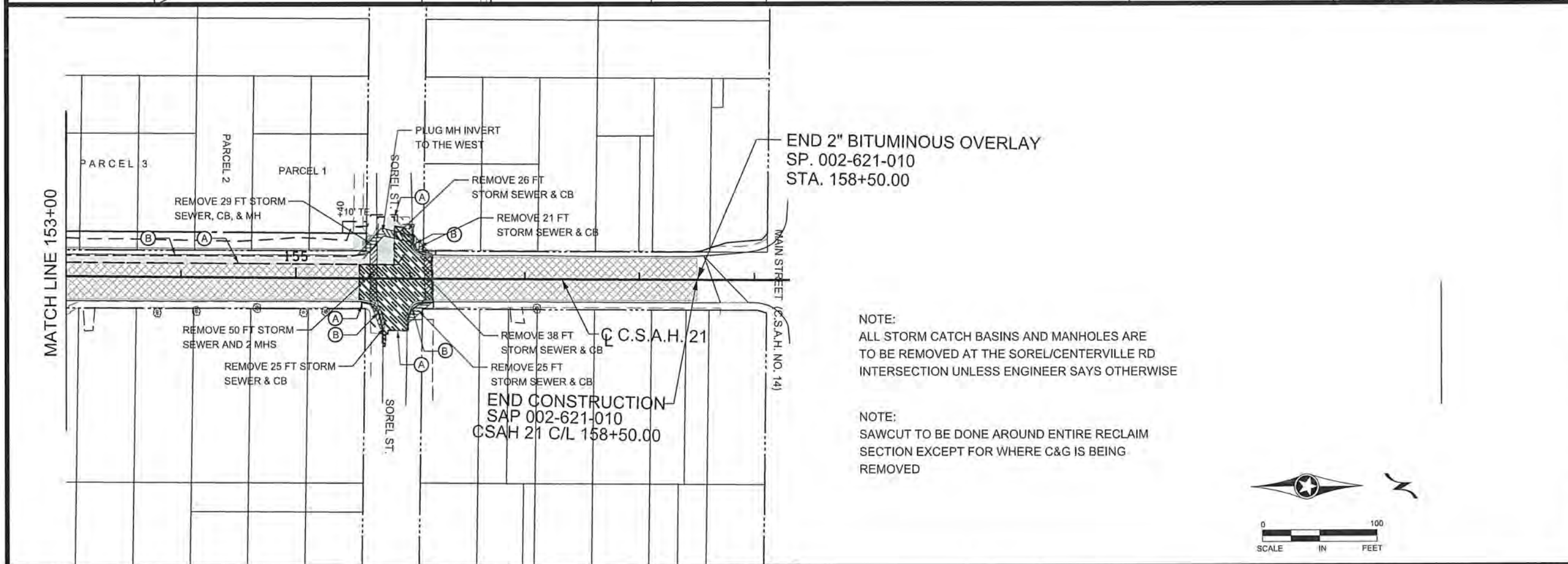

REMOVAL NOTES

THE CONTRACTOR SHALL PERFORM ALL CLEARING AND GRUBBING AS DIRECTED AND MARKED IN THE FIELD BY THE ENGINEER. THE CONTRACTOR SHALL OTHERWISE PROTECT ALL EXISTING TREES NOT SPECIFICALLY MARKED FOR REMOVAL.

ALL MANHOLES AND CATCH BASINS WILL BE PAID FOR AS "REMOVE DRAINAGE "STRUCTURE" ITEM 2104.509 CALLED OUT IN REMOVAL PLANS AS MH AND CB. FOR INFORMATION PURPOSES ONLY.

ALL PRIVATE UTILITIES TO BE RELOCATED BY OTHERS AS REQUIRED. SEE IN PLACE UTILITY TABULATION FOR MORE INFORMATION.

ALL ROADWAY SIGNS WITHIN THE CONSTRUCTION LIMITS AND CONFLICTING SIGNS SHALL BE SALVAGED BY THE CONTRACTOR.

SEE CITY WATERMAIN AND SEWERS PLANS FOR WATERMAIN, HYDRANT, AND SEWER REMOVAL ITEMS.

01	7-21-14	ZB	MN	MNDOT COMMENTS
NO	DATE	BY	CKD	APPR

NAME: P:\02-621-10\Plan\0262110_REM_3.dgn 07/21/2014 10:57:47 AM

I HEREBY CERTIFY THAT THIS PLAN WAS PREPARED BY ME OR UNDER MY DIRECT SUPERVISION AND THAT I AM A DULY LICENSED PROFESSIONAL ENGINEER UNDER THE LAWS OF THE STATE OF MINNESOTA.

PRINT NAME: CURT A. KOBILARCSIK

SIGNATURE: *Curt Kobilarcsik*

DATE: 7-22-14 LICENSE NO. 24756

DRAWN BY: ZB DATE: 07-07-14

DESIGN BY: MN DATE: 07-07-14

CHECKED BY: CAK DATE: 07-11-14

ANOKA COUNTY
HIGHWAY DEPT.

S.A.P. 002-621-010

INPLACE TOPOGRAPHY & REMOVAL PLAN
STA 141+00.00 TO 158+50.00
Sheet 36 of 147 Sheets

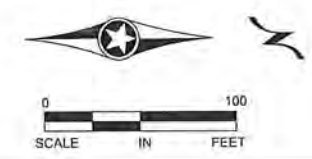

NOTE: ALL STORM CATCH BASINS AND MANHOLES ARE TO BE REMOVED AT THE SOREL/CENTERVILLE RD INTERSECTION UNLESS ENGINEER SAYS OTHERWISE

NOTE: SAWCUT TO BE DONE AROUND ENTIRE RECLAIM SECTION EXCEPT FOR WHERE C&G IS BEING REMOVED

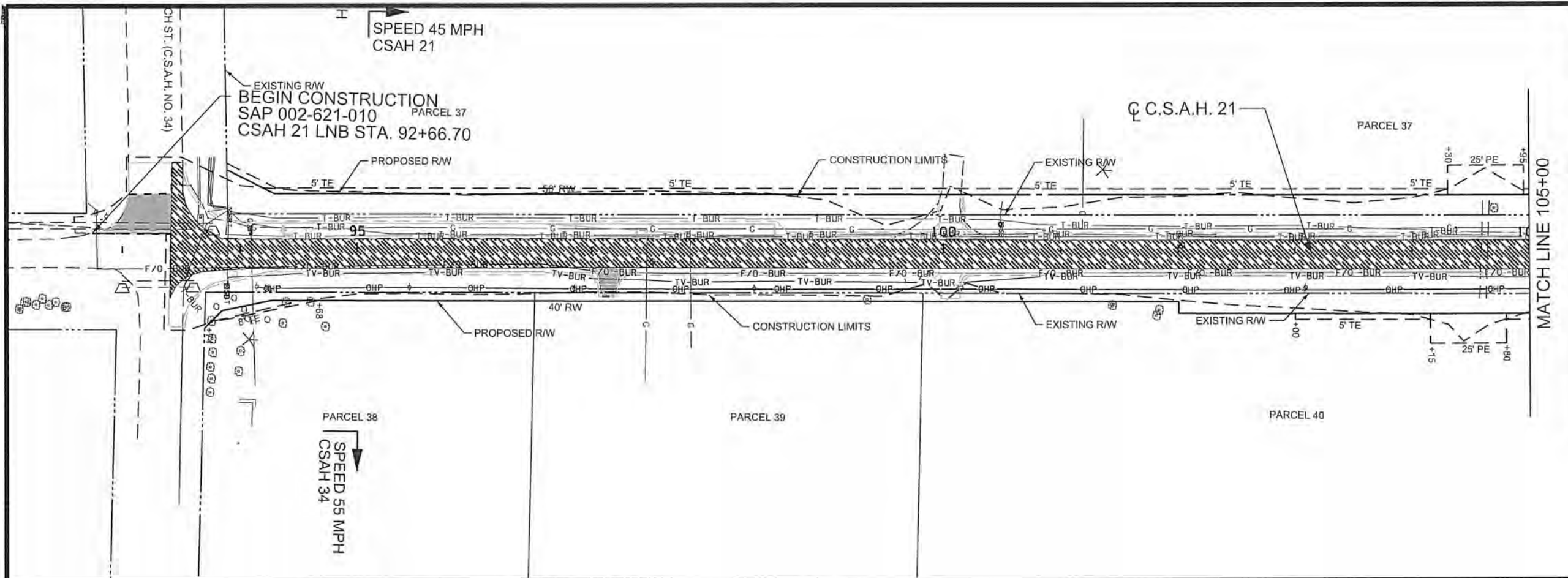

LEGEND

- G — CENTERPOINT ENERGY
- TV-BUR — COMCAST CABLE COMMUNICATIONS
- OHP — CONNEXUS ENERGY/ GREAT RIVER ENERGY
- T-BUR — CENTURYLINK
- F/O -BUR — ZAYO BANDWIDTH
- — — — — EXISTING CULVERT
- — — — — PROPOSED CULVERT
- — — — — PRO STORM SEWER
- — — — — EXISTING R/W
- — — — — PROPOSED R/W
- ▒ REMOVE BITUMINOUS PAVEMENT
- ▨ RECLAIM AND OVERLAY BITUMINOUS PAVEMENT

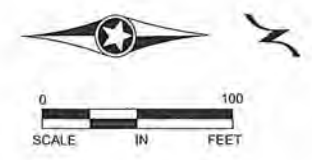
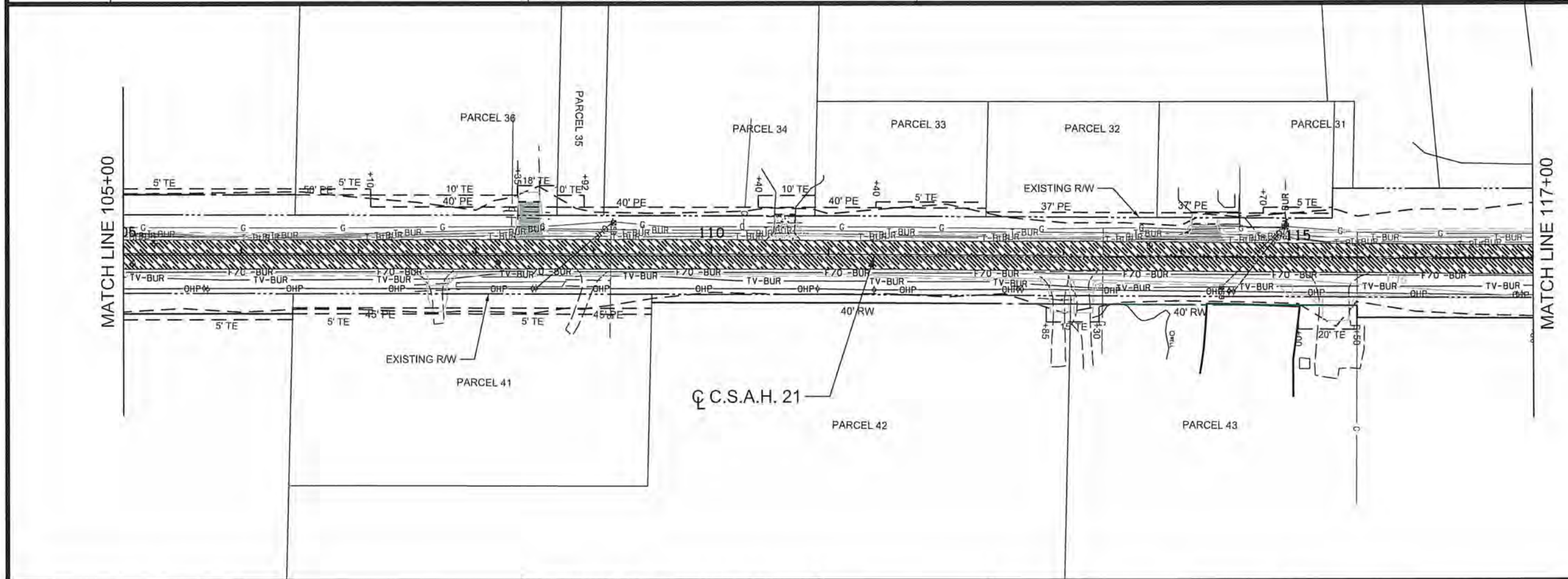
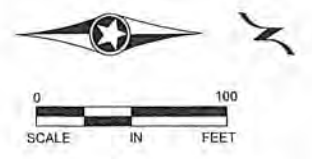

01	7-21-14	ZB	MN		MNDOT COMMENTS
NO	DATE	BY	CKD	APPR	REVISION
NAME: P:\02-621-10\Plan\0262110_UT_1.dgn 07/21/2014 10:57:49 AM					

I HEREBY CERTIFY THAT THIS PLAN WAS PREPARED BY ME OR UNDER MY DIRECT SUPERVISION AND THAT I AM A DULY LICENSED PROFESSIONAL ENGINEER UNDER THE LAWS OF THE STATE OF MINNESOTA.

PRINT NAME: CURT A. KOBIARCSIK

SIGNATURE: *Curt A. Kobiarcsik*

DATE: 7-22-14 LICENSE NO. 24756

DRAWN BY: ZB DATE: 07-07-14

DESIGN BY: MN DATE: 07-07-14

CHECKED BY: CAK DATE: 07-11-14

ANOKA COUNTY
HIGHWAY DEPT.



S.A.P. 002-621-010

EXISTING UTILITY PLAN
STA 92+66.70 TO 117+00.00
Sheet 37 of 147 Sheets

LEGEND

- CENTERPOINT ENERGY
- COMCAST CABLE COMMUNICATIONS
- CONNEXUS ENERGY/ GREAT RIVER ENERGY
- CENTURYLINK
- ZAYO BANDWIDTH
- EXISTING STORM SEWER
- EXIST CITY SAN SEWER
MET COUNCIL SAN SEWER
- EXISTING CULVERT
- EXISTING R/W
- PROPOSED R/W
- REMOVE BITUMINOUS PAVEMENT
- RECLAIM AND OVERLAY BITUMINOUS PAVEMENT

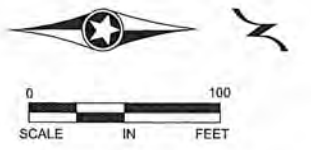
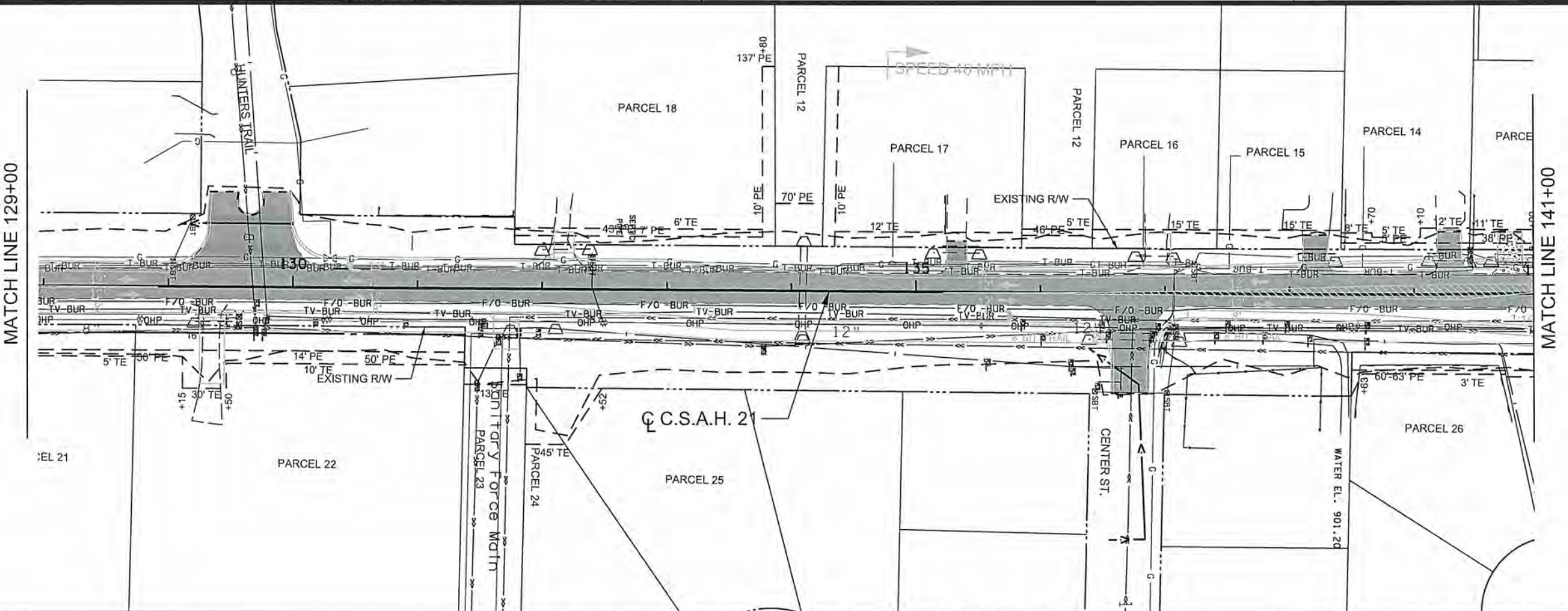
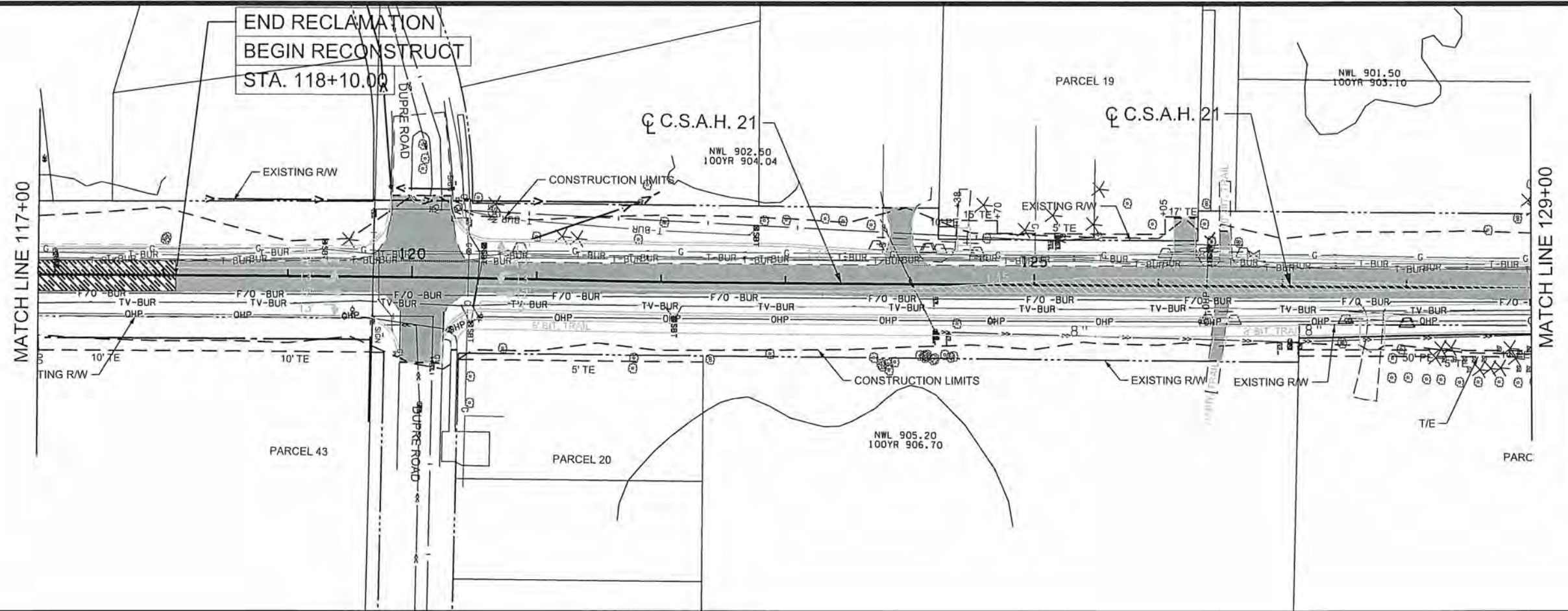

NO	DATE	BY	CKD	APPR	REVISION
NAME: P:\02-621-10\Plan\0262110_UT_2.dgn					
07/11/2014 2:13:23 PM					

I HEREBY CERTIFY THAT THIS PLAN WAS PREPARED BY ME OR UNDER MY DIRECT SUPERVISION AND THAT I AM A DULY LICENSED PROFESSIONAL ENGINEER UNDER THE LAWS OF THE STATE OF MINNESOTA.

PRINT NAME: CURT A. KOBILARCSIK

SIGNATURE: *Curt A. Kobilarsik*

DATE: 7-14-14 LICENSE NO. 24756

DRAWN BY: ZB DATE: 07-07-14

DESIGN BY: MN DATE: 07-07-14

CHECKED BY: CAK DATE: 07-11-14











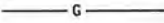

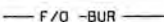

ANOKA COUNTY
HIGHWAY DEPT.

S.A.P. 002-621-010

EXISTING UTILITY PLAN
STA 117+00.00 TO 141+00.00
Sheet 38 of 147 Sheets

LEGEND

-  CENTERPOINT ENERGY
-  COMCAST CABLE COMMUNICATIONS
-  CONNEXUS ENERGY/ GREAT RIVER ENERGY
-  CENTURYLINK
-  ZAYO BANDWIDTH
-  EXISTING STORM SEWER
-  EXIST CITY SAN SEWER/ MET COUNCIL SAN SEWER
-  EXISTING WATER MAIN
-  EXISTING R/W
-  PROPOSED R/W
-  REMOVE BITUMINOUS PAVEMENT
-  MILL AND OVERLAY BITUMINOUS PAVEMENT
-  RECLAIM AND OVERLAY BITUMINOUS PAVEMENT

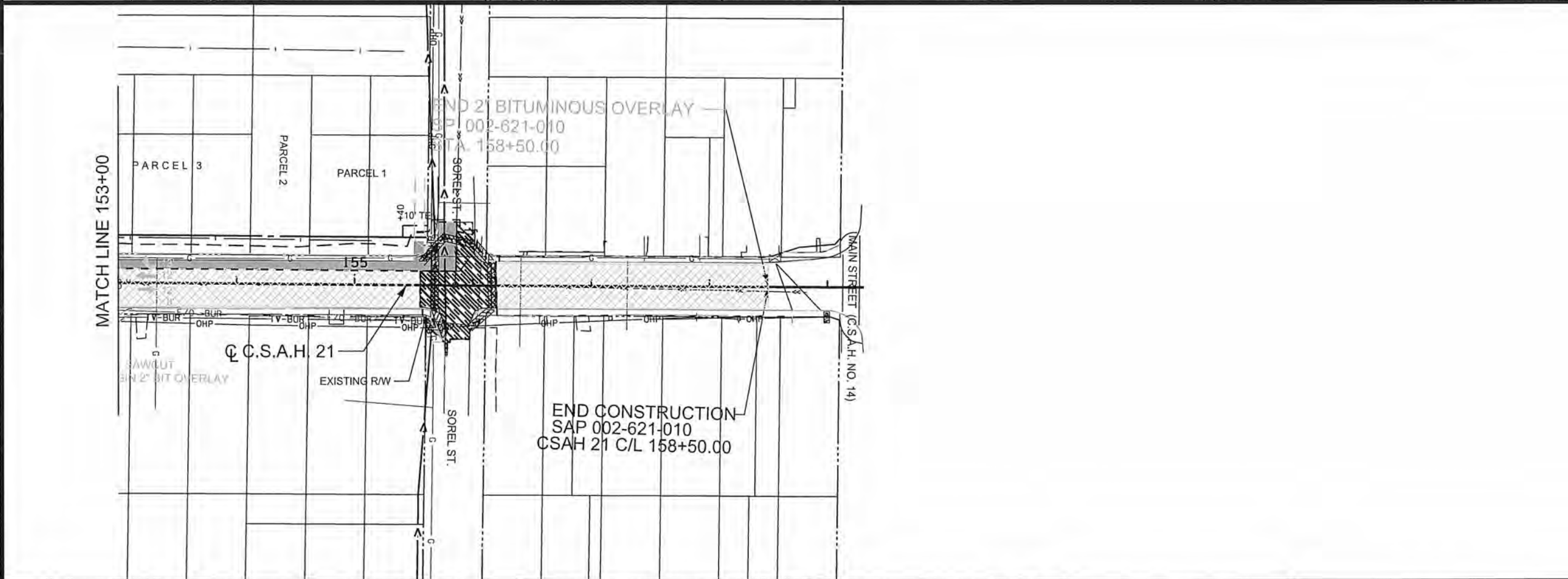
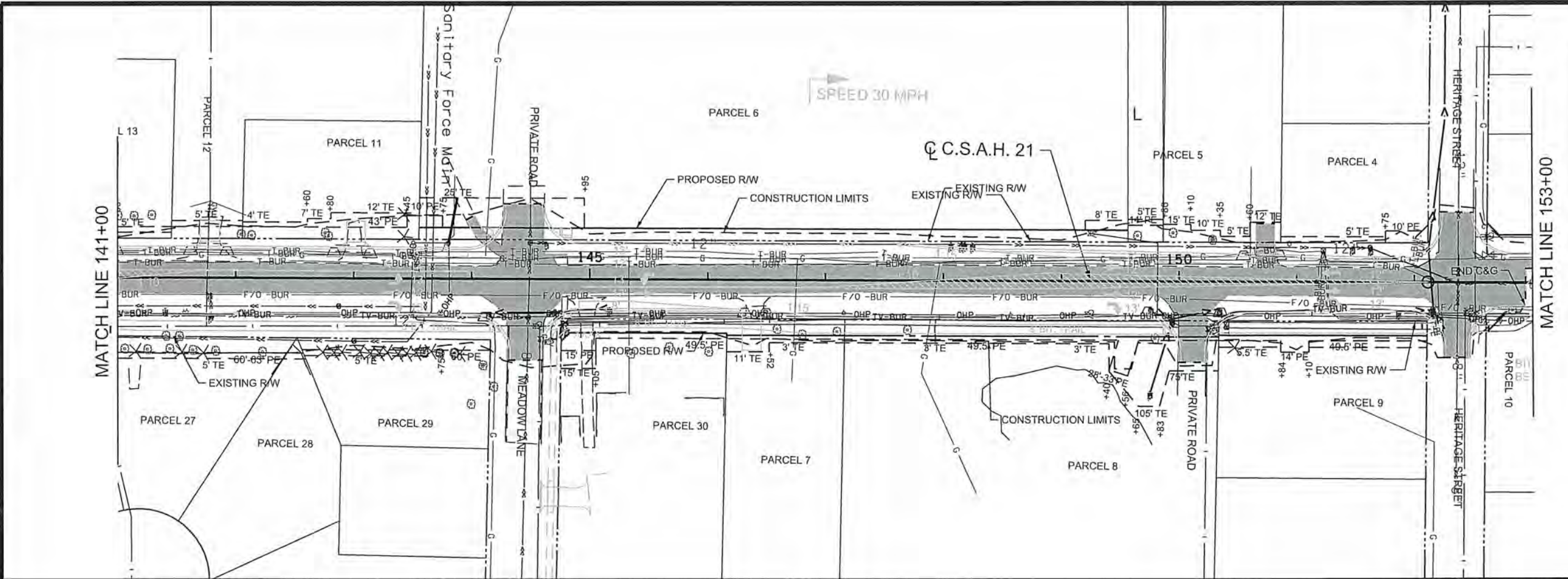
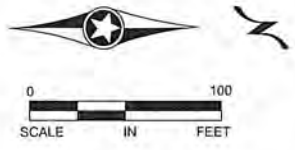
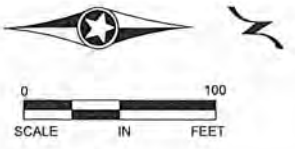

NO	DATE	BY	CKD	APPR	REVISION

NAME: P:\02-621-10\Plan\0262110_UT_3.dgn 07/11/2014 2:13:25 PM

I HEREBY CERTIFY THAT THIS PLAN WAS PREPARED BY ME OR UNDER MY DIRECT SUPERVISION AND THAT I AM A DULY LICENSED PROFESSIONAL ENGINEER UNDER THE LAWS OF THE STATE OF MINNESOTA.

PRINT NAME: CURT A. KOBLARCSIK
 SIGNATURE: *C. Koblarcsik*
 DATE: 7-17-14 LICENSE NO. 24756

DRAWN BY: ZB DATE: 07-07-14
 DESIGN BY: MN DATE: 07-07-14
 CHECKED BY: CAK DATE: 07-11-14



ANOKA COUNTY
 HIGHWAY DEPT.

S.A.P. 002-621-010

EXISTING UTILITY PLAN
 STA 141+00.00 TO 158+50.00
 Sheet 39 of 147 Sheets

LEGEND	
(A)	EDGE OF BITUMINOUS
(B)	2' UNPAVED SHOULDER
(D)	BITUMINOUS DRIVEWAY
(E)	GRAVEL DRIVEWAY

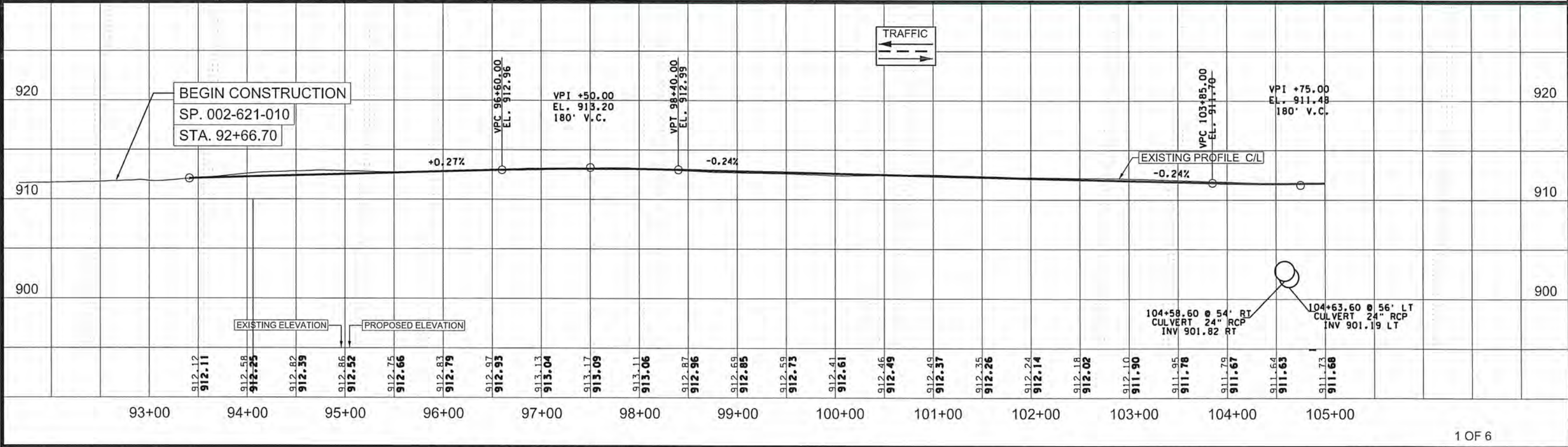
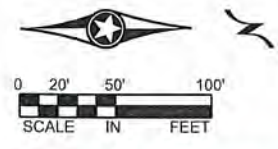
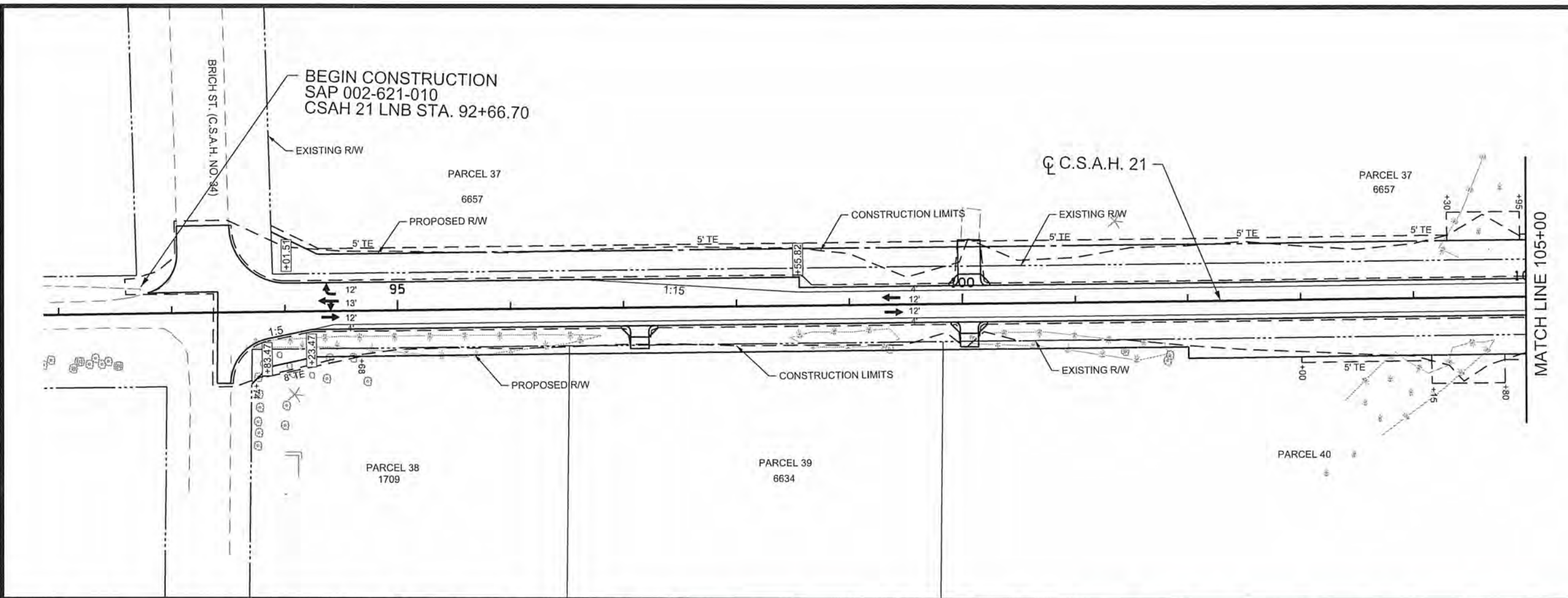

1 OF 6

NO	DATE	BY	CKD	APPR	REVISION

NAME: P:\02-621-10\Plan\0262110_PP1.dgn 07/11/2014 1:38:17 PM

I HEREBY CERTIFY THAT THIS PLAN WAS PREPARED BY ME OR UNDER MY DIRECT SUPERVISION AND THAT I AM A DULY LICENSED PROFESSIONAL ENGINEER UNDER THE LAWS OF THE STATE OF MINNESOTA.

PRINT NAME: CURT KOBILARCSIK
 SIGNATURE: *Curt Kobilarsik*
 DATE: 7-14-14 LICENSE NO. 24756

DRAWN BY: ZB DATE: 07-07-14
 DESIGN BY: MN DATE: 07-07-14
 CHECKED BY: CAK DATE: 07-11-14

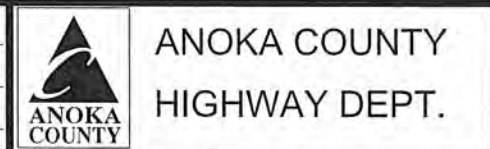

ANOKA COUNTY
 HIGHWAY DEPT.

S.A.P. 002-621-010

CONSTRUCTION PLAN
 AND PROFILE
 STA 92+66.70 TO 105+00.00
 Sheet 40 of 147 Sheets

LEGEND	
(A)	EDGE OF BITUMINOUS
(B)	2' UNPAVED SHOULDER
(C)	CONCRETE DRIVEWAY
(D)	BITUMINOUS DRIVEWAY
(E)	GRAVEL DRIVEWAY

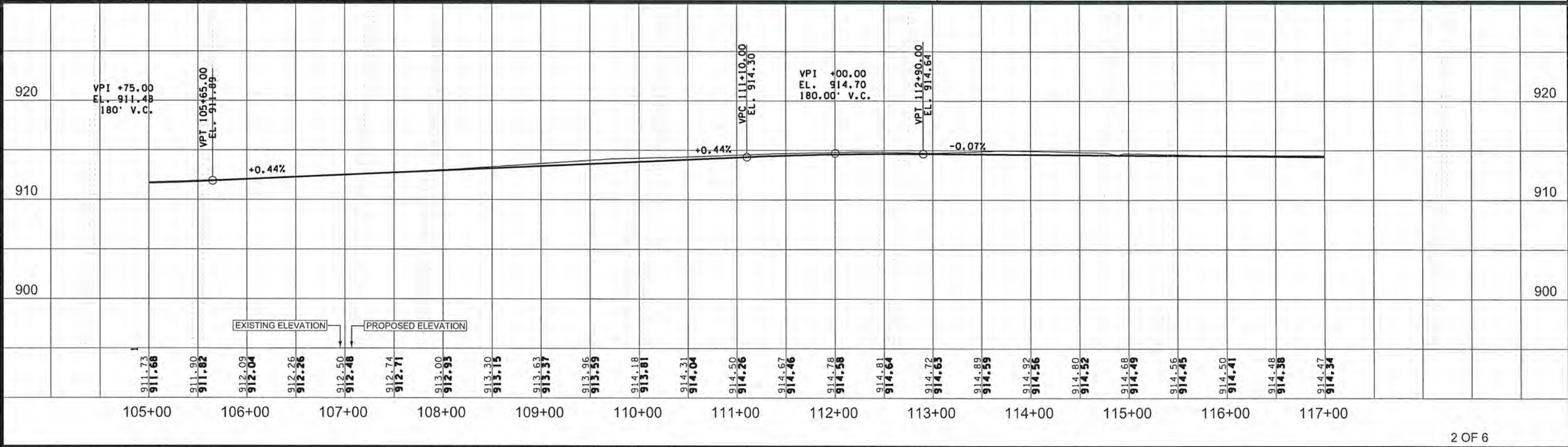
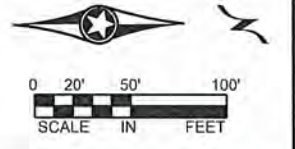
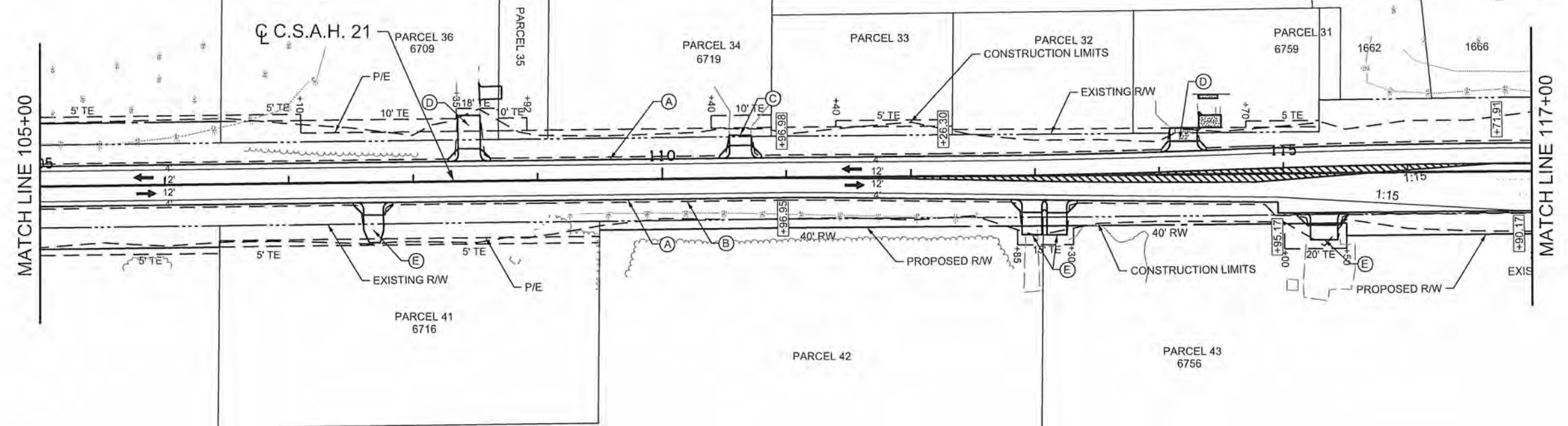

2 OF 6

NO	DATE	BY	CKD	APPR	REVISION

NAME: P:\02-621-10\Plan\0262110_PP2.dgn 07/11/2014 1:38:18 PM

I HEREBY CERTIFY THAT THIS PLAN WAS PREPARED BY ME OR UNDER MY DIRECT SUPERVISION AND THAT I AM A DULY LICENSED PROFESSIONAL ENGINEER UNDER THE LAWS OF THE STATE OF MINNESOTA.

PRINT NAME: CURT KOBILARCSIK
 SIGNATURE: *Curt Kobilarsik*
 DATE: 7-14-14 LICENSE NO. 24756

DRAWN BY: ZB DATE: 07-07-14
 DESIGN BY: MN DATE: 07-07-14
 CHECKED BY: CAK DATE: 07-11-14

ANOKA COUNTY
HIGHWAY DEPT.

S.A.P. 002-621-010

CONSTRUCTION PLAN AND PROFILE
 STA 105+00.00 TO 117+00.00
 Sheet 41 of 147 Sheets

- LEGEND**
- (D) BITUMINOUS DRIVEWAY
 - (E) GRAVEL DRIVEWAY
 - (F) PEDESTRIAN CURB RAMP & TRUNCATED DOME
 - (H) B424 CURB & GUTTER
 - (I) MATCH S412 CURB & GUTTER

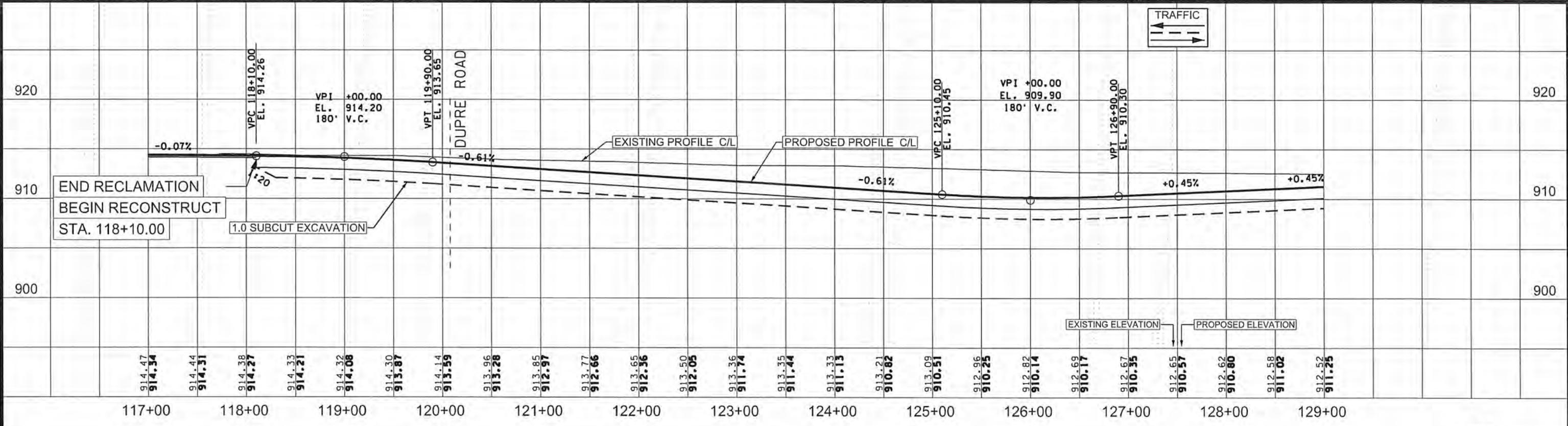
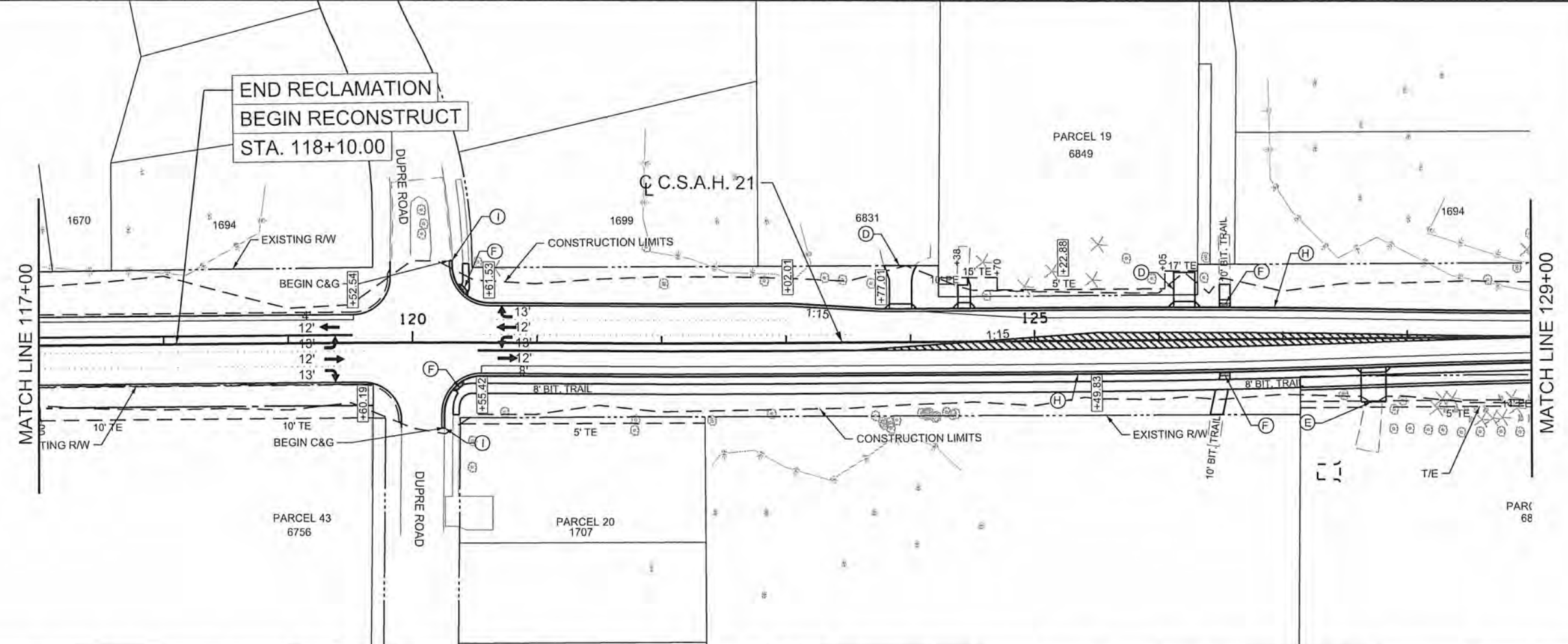

NO	DATE	BY	CKD	APPR	REVISION

NAME: P:\02-621-10\Plan\0262110_PP3.dgn 07/11/2014 1:38:20 PM

I HEREBY CERTIFY THAT THIS PLAN WAS PREPARED BY ME OR UNDER MY DIRECT SUPERVISION AND THAT I AM A DULY LICENSED PROFESSIONAL ENGINEER UNDER THE LAWS OF THE STATE OF MINNESOTA.

PRINT NAME: CURT KOBILARCSIK
 SIGNATURE: *Curt Kobilarsik*
 DATE: 7-14-14 LICENSE NO. 24756

DRAWN BY: ZB DATE: 07-07-14
 DESIGN BY: MN DATE: 07-07-14
 CHECKED BY: CAK DATE: 07-11-14

ANOKA COUNTY
HIGHWAY DEPT.

S.A.P. 002-621-010

3 OF 6

CONSTRUCTION PLAN AND PROFILE
 STA 117+00.00 TO 129+00.00
 Sheet 42 of 147 Sheets

- LEGEND**
- (D) BITUMINOUS DRIVEWAY
 - (E) GRAVEL DRIVEWAY
 - (F) PEDESTRIAN CURB RAMP & TRUNCATED DOME
 - (H) B424 CURB & GUTTER
 - (I) MATCH S412 CURB & GUTTER

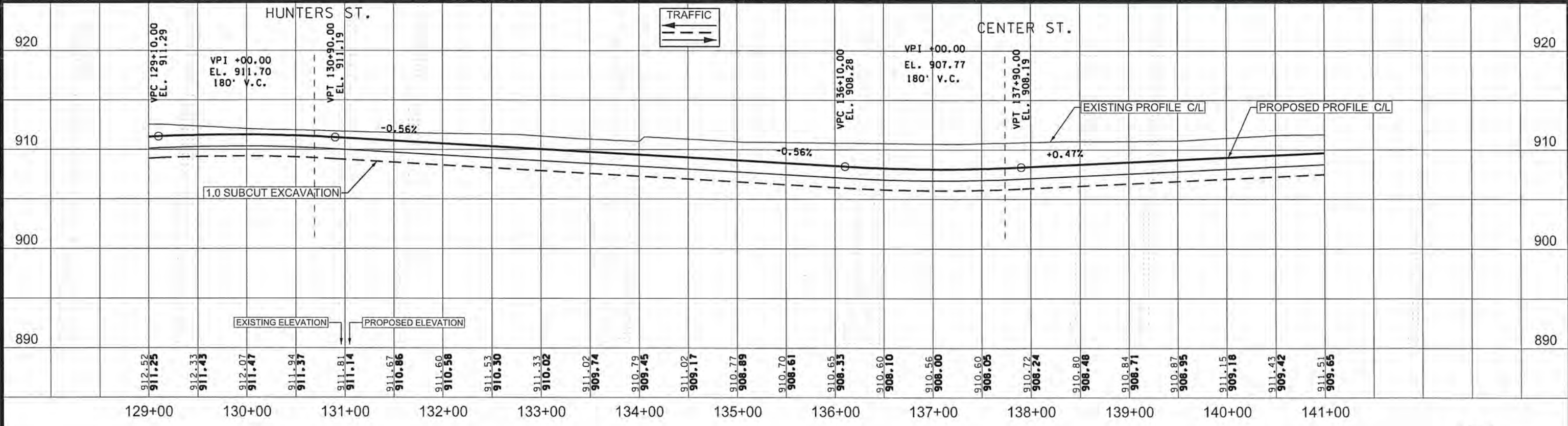
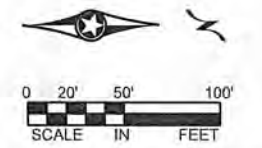
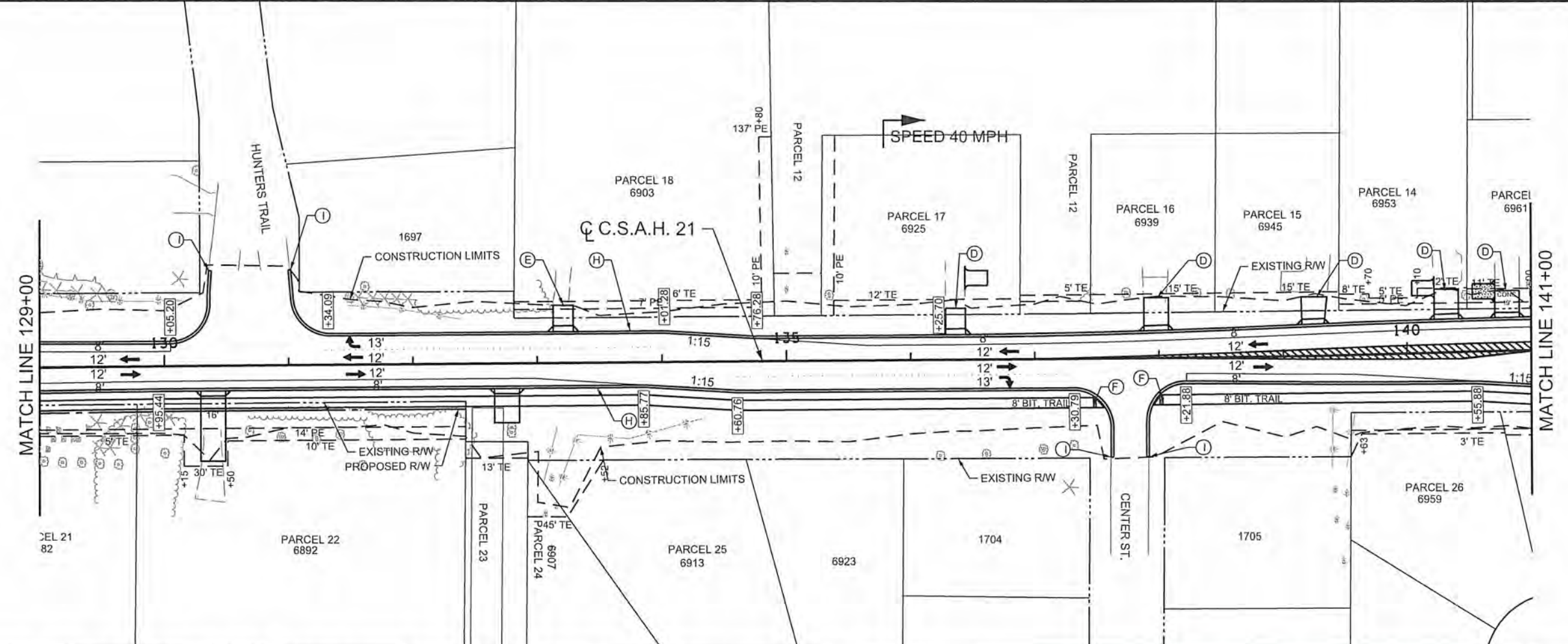

4 OF 6

NO	DATE	BY	CKD	APPR	REVISION

NAME: P:\02-621-10\Plan\0262110_PP4.dgn 07/11/2014 1:38:22 PM

I HEREBY CERTIFY THAT THIS PLAN WAS PREPARED BY ME OR UNDER MY DIRECT SUPERVISION AND THAT I AM A DULY LICENSED PROFESSIONAL ENGINEER UNDER THE LAWS OF THE STATE OF MINNESOTA.

PRINT NAME: CURT KOBILARCSIK
 SIGNATURE: *Curt Kobilarsik*
 DATE: 7-14-14 LICENSE NO. 24756

DRAWN BY: ZB DATE: 07-07-14
 DESIGN BY: MN DATE: 07-07-14
 CHECKED BY: CK DATE: 07-11-14

ANOKA COUNTY
HIGHWAY DEPT.

S.A.P. 002-621-010

CONSTRUCTION PLAN AND PROFILE
 STA 129+00.00 TO 141+00.00
 Sheet 43 of 147 Sheets

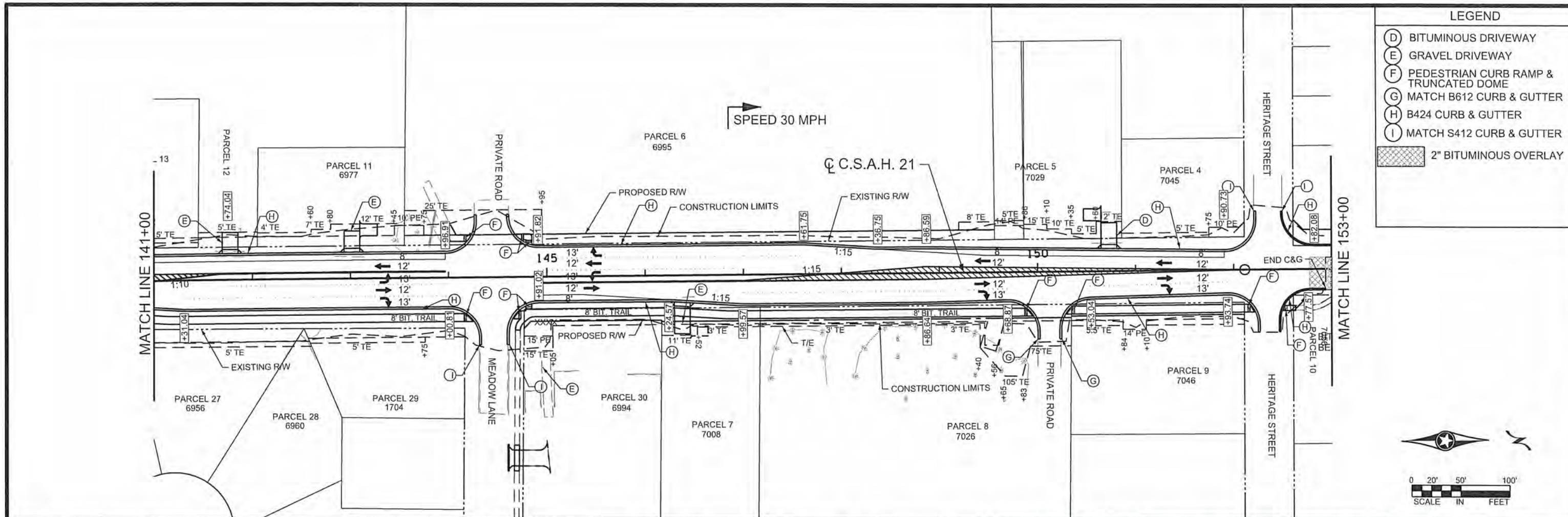

LEGEND

- (D) BITUMINOUS DRIVEWAY
- (E) GRAVEL DRIVEWAY
- (F) PEDESTRIAN CURB RAMP & TRUNCATED DOME
- (G) MATCH B612 CURB & GUTTER
- (H) B424 CURB & GUTTER
- (I) MATCH S412 CURB & GUTTER
- [Hatched Box] 2" BITUMINOUS OVERLAY

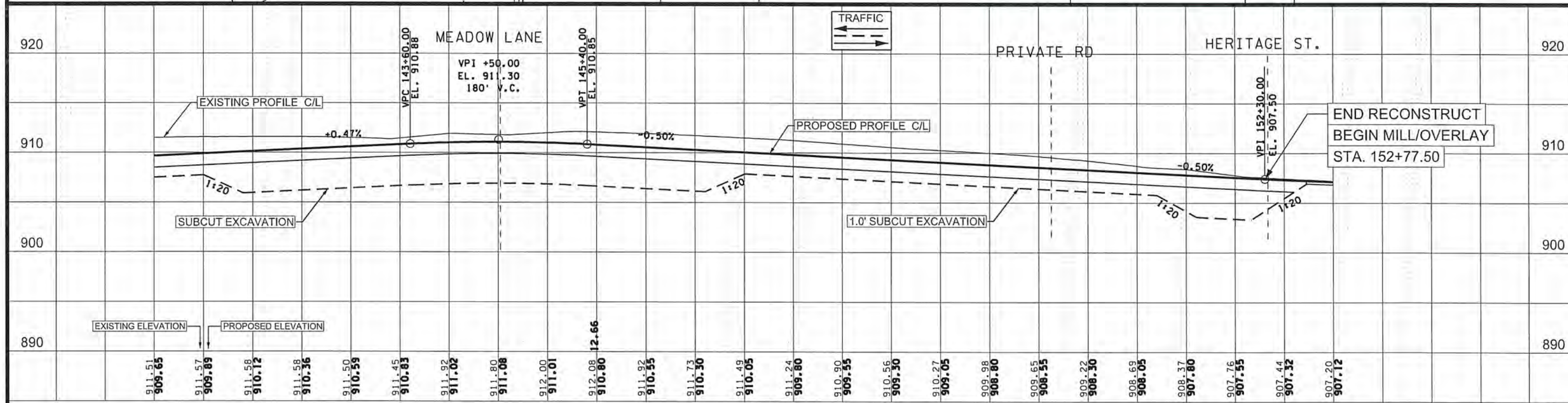
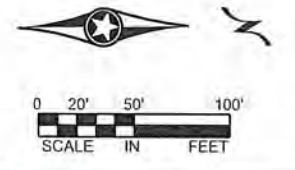

5 OF 6

NO	DATE	BY	CKD	APPR	REVISION

NAME: P:\02-621-10\Plan\0262110_PP5.dgn
07/11/2014 1:38:24 PM

I HEREBY CERTIFY THAT THIS PLAN WAS PREPARED BY ME OR UNDER MY DIRECT SUPERVISION AND THAT I AM A DULY LICENSED PROFESSIONAL ENGINEER UNDER THE LAWS OF THE STATE OF MINNESOTA.

PRINT NAME: CURT KOBILARCSIK
SIGNATURE: *Curt Kobilarsik*
DATE: 7-14-14 LICENSE NO. 24756

DRAWN BY: ZB DATE: 07-07-14
DESIGN BY: MN DATE: 07-07-14
CHECKED BY: CAK DATE: 07-11-14

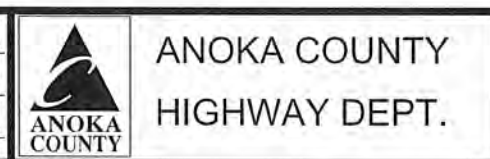

S.A.P. 002-621-010

CONSTRUCTION PLAN AND PROFILE
STA 141+00.00 TO 153+00.00
Sheet 44 of 147 Sheets

LEGEND	
(F)	PEDESTRIAN CURB RAMP & TRUNCATED DOME
(J)	BIT. CURB & GUTTER
(K)	MATCH BIT. CURB & GUTTER
	2" BITUMINOUS OVERLAY

NOTE:
BITUMINOUS CURB IS ONLY TO BE BUILT WHERE EXISTING BITUMINOUS CURB WAS REMOVED

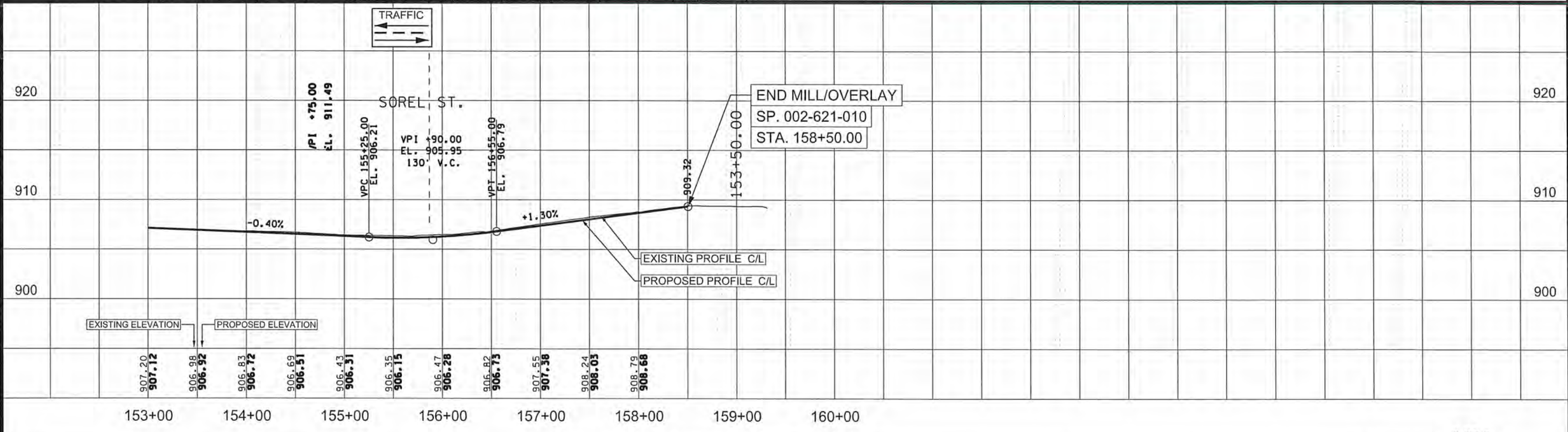
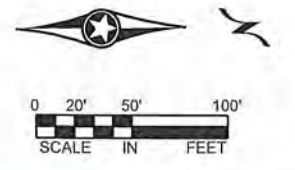
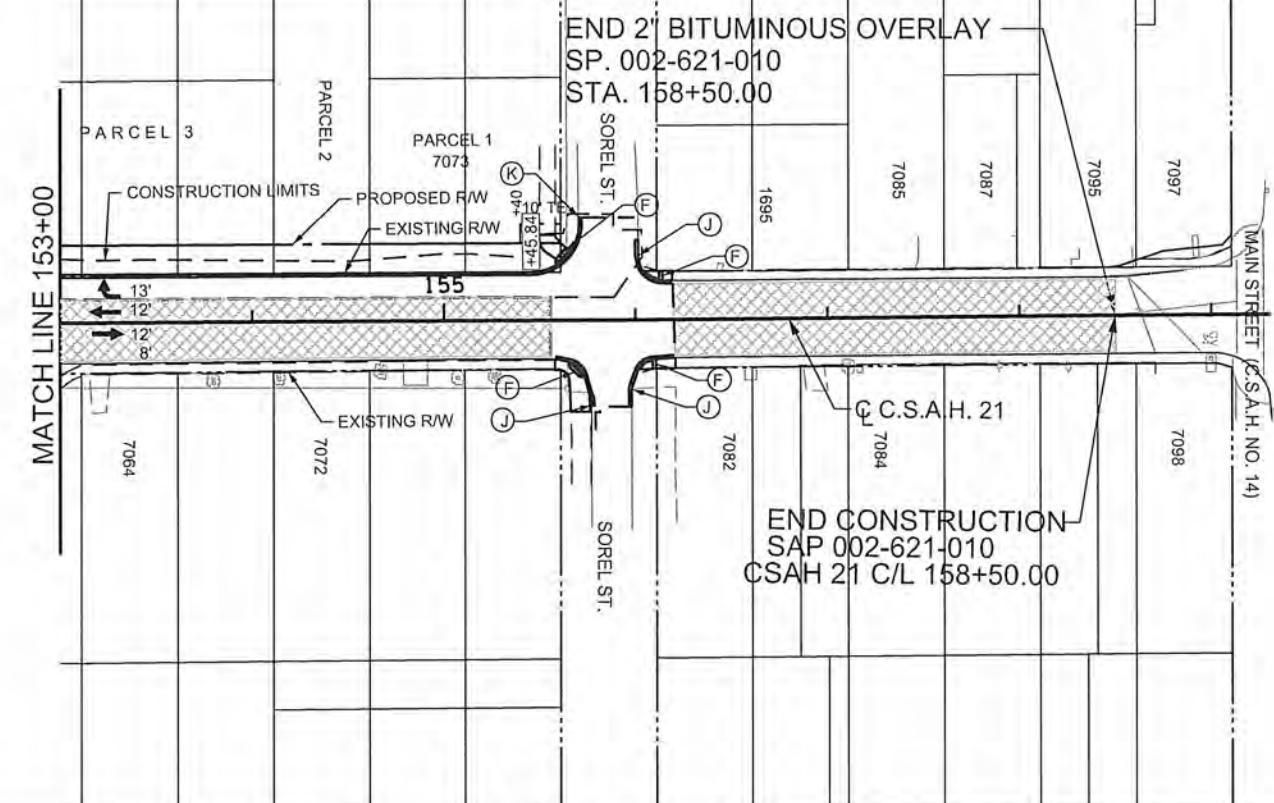

6 OF 6

NO	DATE	BY	CKD	APPR	REVISION

NAME: P:\02-621-10\Plan\0262110_PP6.dgn 07/11/2014 1:38:25 PM

I HEREBY CERTIFY THAT THIS PLAN WAS PREPARED BY ME OR UNDER MY DIRECT SUPERVISION AND THAT I AM A DULY LICENSED PROFESSIONAL ENGINEER UNDER THE LAWS OF THE STATE OF MINNESOTA.

PRINT NAME: CURT KOBILARCSIK
SIGNATURE: *Curt Kobilarsik*
DATE: 7-14-14 LICENSE NO. 24756

DRAWN BY: ZB DATE: 07-07-14
DESIGN BY: MN DATE: 07-07-14
CHECKED BY: CAK DATE: 07-11-14

 ANOKA COUNTY
HIGHWAY DEPT.

S.A.P. 002-621-010

CONSTRUCTION PLAN AND PROFILE
STA 153+00.00 TO 158+50.00
Sheet 45 of 147 Sheets

CSAH 21 AT DUPRE ROAD (WEST)

POINT	ALIGNMENT	STATION	LOCATION	ELEVATION	SLOPE %	FROM - TO	DESCRIPTION
A1	CSAH 21	119+52.54	22.50' LT	913.41			BEGIN RADIUS
A2	CSAH 21	119+73.68	31.31' LT	913.19	-0.92%	A1 - A2	MIDPOINT
A3	CSAH 21	119+82.37	52.55' LT	912.97	-0.92%	A2 - A3	END RADIUS
M1	CSAH 21	119+82.33	64.98' LT	912.86	0.76%	A3 - M1	MATCH POINT
RA1	CSAH 21	119+52.54	52.50' LT	-			RADIUS PT
M2	CSAH 21	120+30.23	64.93' LT	912.73			
A4	CSAH 21	120+30.23	61.50' LT	912.72	-0.37%	M2 - A4	BEGIN RADIUS
A5	CSAH 21	120+39.61	38.87' LT	912.63	-0.37%	A4 - A5	MIDPOINT
A6	CSAH 21	120+62.23	29.50' LT	912.53	-0.37%	A5 - A6	END RADIUS
A7	CSAH 21	120+40.54	48.69' LT	912.63			SW EDGE
A8	CSAH 21	120+45.49	48.73' LT	912.69			SW EDGE
A9	CSAH 21	120+40.23	62.80' LT	913.33			EXISTING SW
A10	CSAH 21	120+45.49	62.85' LT	913.27			EXISTING SW
RA2	CSAH 21	120+62.23	61.50' LT	-			RADIUS PT

CONSTRUCTION LIMITS

RA1 = 30'

+

RA2 = 30'

+

☉ C.S.A.H. 21

C.S.A.H. 21

CSAH 21 AT DUPRE ROAD (EAST)

POINT	ALIGNMENT	STATION	LOCATION	ELEVATION	SLOPE %	FROM - TO	DESCRIPTION
A11	CSAH 21	119+60.19	31.50' RT	913.14			BEGIN RADIUS
A12	CSAH 21	119+81.60	40.34' RT	913.21	0.29%	A8 - A7	MIDPOINT
A13	CSAH 21	119+90.41	61.70' RT	913.27	0.29%	A9 - A8	END RADIUS
M3	CSAH 21	119+90.37	67.95' RT	913.29	0.29%	M3 - A9	MATCH POINT
RA3	CSAH 21	119+60.16	61.50' RT	-			RADIUS POINT
M4	CSAH 21	120+23.20	68.10' RT	913.33			MATCH POINT
A14	CSAH 21	120+22.81	56.17' RT	913.21	-0.93%	M4 - A10	BEGIN RADIUS
A15	CSAH 21	120+32.30	33.76' RT	912.98	-0.93%	A10 - A11	MIDPOINT
A16	CSAH 21	120+54.81	24.50' RT	912.75	-0.93%	A11 - A12	END RADIUS
A17	CSAH 21	120+39.87	44.36' RT	913.39			SW EDGE
A18	CSAH 21	120+47.19	40.52' RT	913.40			SW EDGE
A19	CSAH 21	120+32.20	57.51' RT	913.74			EXISTING SW
A20	CSAH 21	120+37.23	57.59' RT	913.79			EXISTING SW
RA4	CSAH 21	120+54.81	56.50' RT	-			RADIUS POINT

EXISTING R/W
CONSTRUCTION LIMITS

RA3 = 30'

+

RA4 = 30'

+

T/E

CONSTRUCTION LIMITS

DUPRE ROAD

EXISTING R/W

LEGEND

- 999.99 EXISTING SPOT ELEVATION
- 999.99 PROPOSED SPOT ELEVATION
- 2.00 PROPOSED LANE SLOPE (%)
- SAWCUT
- 2.00% CROSS SLOPE
- 2.50% CROSS SLOPE
- CONTROL POINTS
- ▭ TRUNCATED DOMES (SEE STANDARD PLATE 7038)
- X" CURB HEIGHT
- Ⓢ INDICATES PEDESTRIAN RAMP - SLOPE SHALL BE GREATER THAN 2.0% AND LESS THAN 5.0% IN THE DIRECTION SHOWN AND CROSS SLOPE SHALL NOT EXCEED 2.0%

ELEVATIONS ARE TOP OF FINISHED PAVEMENT

CURB AND GUTTER ELEVATIONS ARE SHOWN AT TOP OF FINISHED BITUMINOUS AT LIP OF GUTTER UNLESS OTHERWISE NOTED

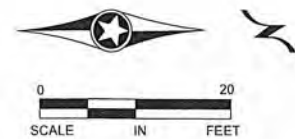

NO	DATE	BY	CKD	APPR	REVISION

I HEREBY CERTIFY THAT THIS PLAN WAS PREPARED BY ME OR UNDER MY DIRECT SUPERVISION AND THAT I AM A DULY LICENSED PROFESSIONAL ENGINEER UNDER THE LAWS OF THE STATE OF MINNESOTA.
 PRINT NAME: CURT A. KOBILARCSIK
 SIGNATURE: *Curt A. Kobilarsik*
 DATE: 7-14-14 LICENSE NO. 24756

DRAWN BY: ZB DATE: 07-07-14
 DESIGN BY: MN DATE: 07-07-14
 CHECKED BY: CAK DATE: 07-11-14

ANOKA COUNTY
HIGHWAY DEPT.

S.A.P. 002-621-010

INTERSECTION DETAILS
 CSAH 21 AND DUPRE RD
 Sheet 46 of 147 Sheets

CSAH 21 AT HUNTERS TRAIL						
POINT	ALIGNMENT	STATION	LOCATION	ELEVATION	SLOPE % FROM - TO	DESCRIPTION
B1	CSAH 21	130+05.20	18.00' LT	911.10		BEGIN RADIUS
B2	CSAH 21	130+27.83	27.37' LT	910.98	-0.47% B1 - B2	MIDPOINT
B3	CSAH 21	130+37.20	50.00' LT	910.86	-0.47% B2 - B3	END RADIUS
MB1	CSAH 21	130+38.56	76.11' LT	910.74	-0.47% B3 - MB1	MATCH POINT
RB1	CSAH 21	130+05.26	59.50' LT	-		RADIUS PT
MB2	CSAH 21	131+00.37	76.20' LT	910.86		MATCH POINT
B4	CSAH 21	131+02.18	52.56' LT	910.71	-0.63% MB2 - B4	END RADIUS
B5	CSAH 21	131+12.34	31.52' LT	910.56	-0.63% B4 - B5	MIDPOINT
B6	CSAH 21	131+34.09	23.00' LT	910.41	-0.63% B5 - B6	BEGIN RADIUS
RB2	CSAH 21	131+33.22	61.50' LT	-		RADIUS PT

- LEGEND**
- 999.99 EXISTING SPOT ELEVATION
 - 999.99 PROPOSED SPOT ELEVATION
 - 2.00 PROPOSED LANE SLOPE (%)
 - SAWCUT
 - 2.00% CROSS SLOPE
 - 2.50% CROSS SLOPE
 - PROPOSED CATCH BASIN

ELEVATIONS ARE TOP OF FINISHED PAVEMENT
 CURB AND GUTTER ELEVATIONS ARE SHOWN AT TOP OF FINISHED BITUMINOUS AT LIP OF GUTTER UNLESS OTHERWISE NOTED

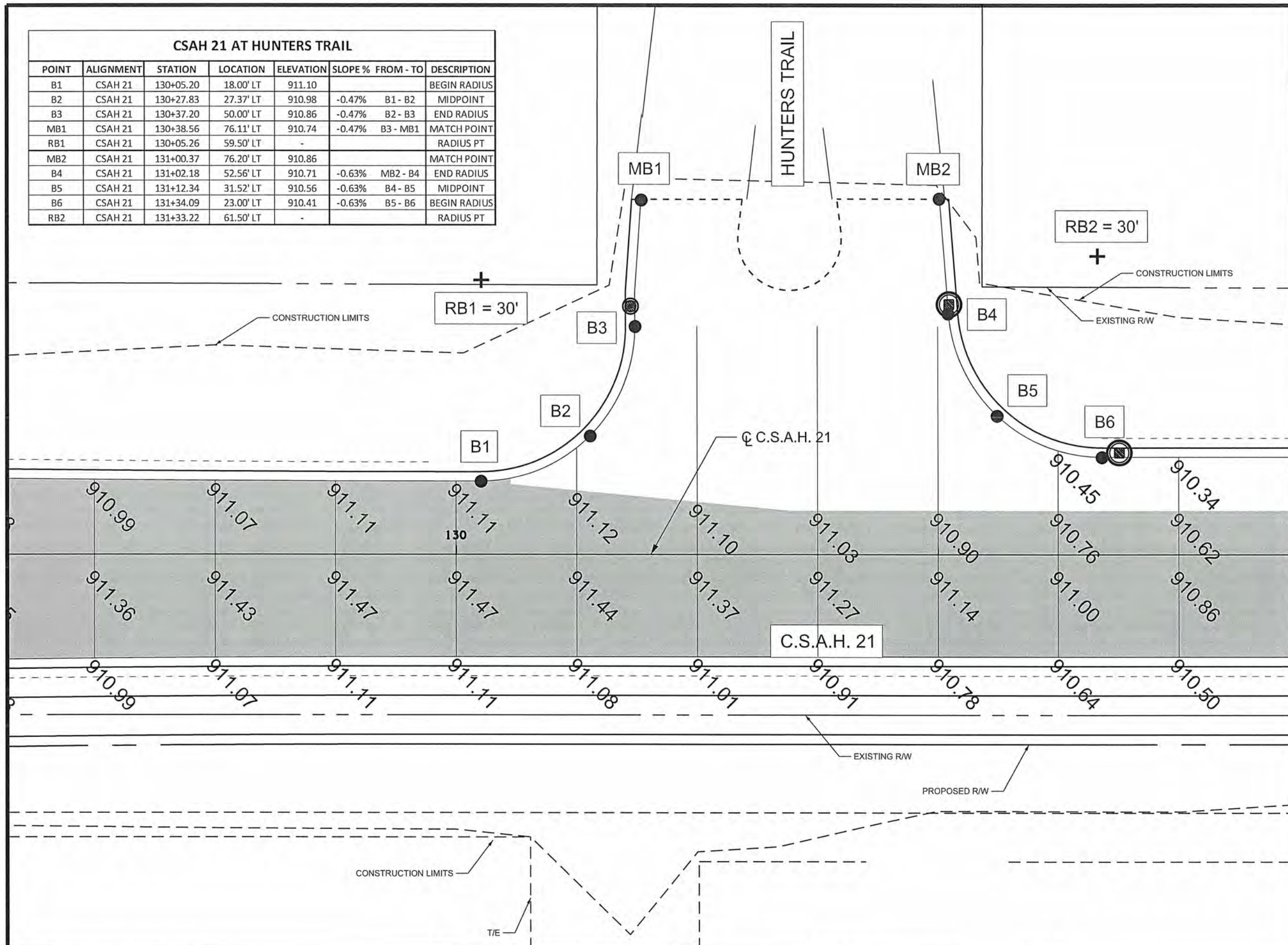

NO	DATE	BY	CKD	APPR	REVISION

NAME: P:\02-621-10\Plan\0262110_INT2_HUNTERS.dgn 07/11/2014 1:38:32 PM

I HEREBY CERTIFY THAT THIS PLAN WAS PREPARED BY ME OR UNDER MY DIRECT SUPERVISION AND THAT I AM A DULY LICENSED PROFESSIONAL ENGINEER UNDER THE LAWS OF THE STATE OF MINNESOTA.
 PRINT NAME: CURT A. KOBILARCSIK
 SIGNATURE: *Curt Kobilarcsik*
 DATE: 7-14-14 LICENSE NO. 24756

DRAWN BY: ZB DATE: 07-07-14
 DESIGN BY: MN DATE: 07-07-14
 CHECKED BY: CAK DATE: 07-11-14

ANOKA COUNTY
HIGHWAY DEPT.

S.A.P. 002-621-010

INTERSECTION DETAILS
 CSAH 21 AND HUNTERS TRAIL
 Sheet 47 of 147 Sheets

LEGEND

- 999.99 EXISTING SPOT ELEVATION
- 999.99 PROPOSED SPOT ELEVATION
- 2.00 PROPOSED LANE SLOPE (%)
- SAWCUT
- 2.00% CROSS SLOPE
- 2.50% CROSS SLOPE
- PROPOSED CATCH BASIN / MANHOLE

ELEVATIONS ARE TOP OF FINISHED PAVEMENT

CURB AND GUTTER ELEVATIONS ARE SHOWN AT TOP OF FINISHED BITUMINOUS AT LIP OF GUTTER UNLESS OTHERWISE NOTED

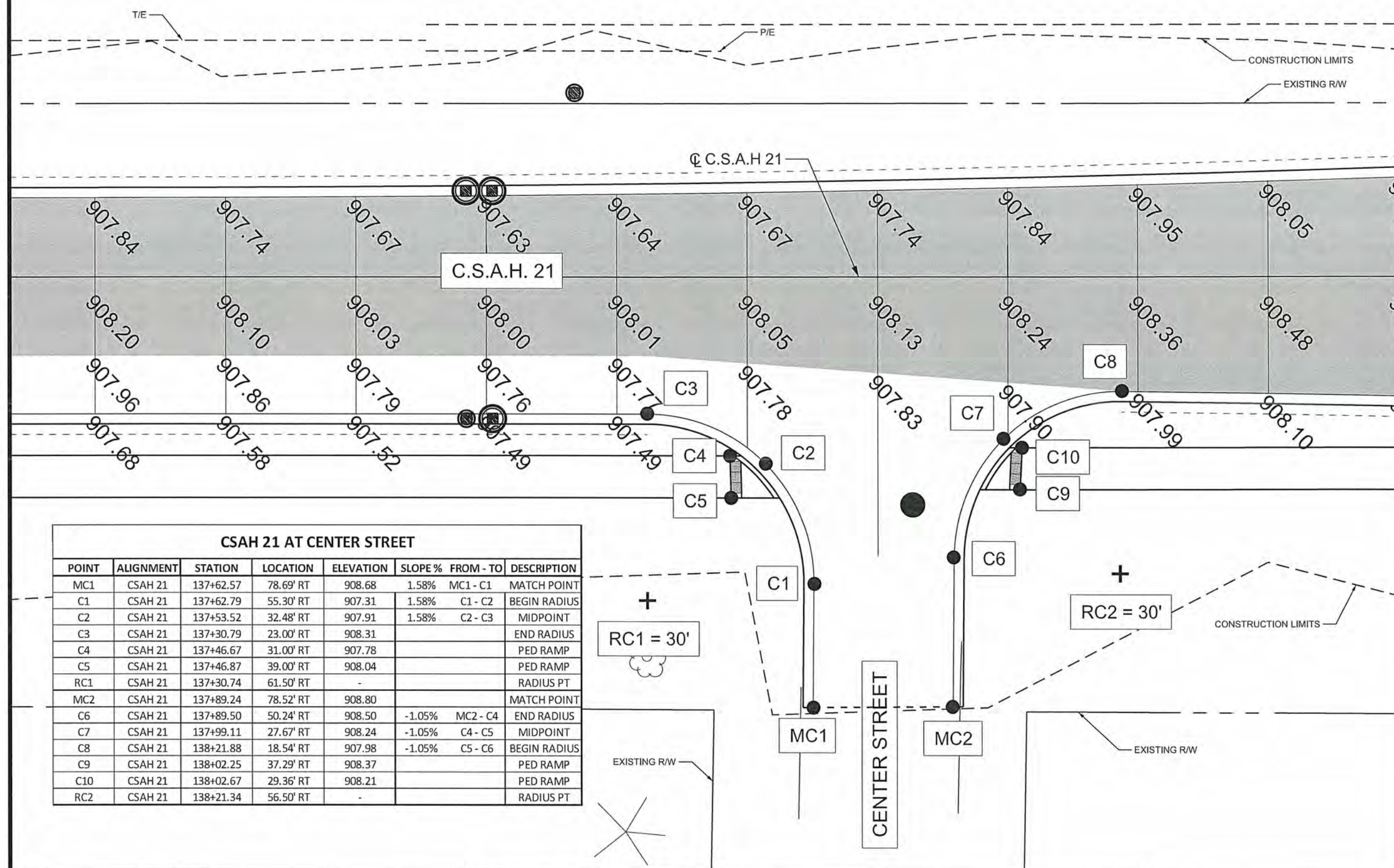

CSAH 21 AT CENTER STREET

POINT	ALIGNMENT	STATION	LOCATION	ELEVATION	SLOPE %	FROM - TO	DESCRIPTION
MC1	CSAH 21	137+62.57	78.69' RT	908.68	1.58%	MC1 - C1	MATCH POINT
C1	CSAH 21	137+62.79	55.30' RT	907.31	1.58%	C1 - C2	BEGIN RADIUS
C2	CSAH 21	137+53.52	32.48' RT	907.91	1.58%	C2 - C3	MIDPOINT
C3	CSAH 21	137+30.79	23.00' RT	908.31			END RADIUS
C4	CSAH 21	137+46.67	31.00' RT	907.78			PED RAMP
C5	CSAH 21	137+46.87	39.00' RT	908.04			PED RAMP
RC1	CSAH 21	137+30.74	61.50' RT	-			RADIUS PT
MC2	CSAH 21	137+89.24	78.52' RT	908.80			MATCH POINT
C6	CSAH 21	137+89.50	50.24' RT	908.50	-1.05%	MC2 - C4	END RADIUS
C7	CSAH 21	137+99.11	27.67' RT	908.24	-1.05%	C4 - C5	MIDPOINT
C8	CSAH 21	138+21.88	18.54' RT	907.98	-1.05%	C5 - C6	BEGIN RADIUS
C9	CSAH 21	138+02.25	37.29' RT	908.37			PED RAMP
C10	CSAH 21	138+02.67	29.36' RT	908.21			PED RAMP
RC2	CSAH 21	138+21.34	56.50' RT	-			RADIUS PT

NO	DATE	BY	CKD	APPR	REVISION

NAME: P:\02-621-10\Plan\0262110_INT3_CENTER.dgn 07/11/2014 1:38:34 PM

I HEREBY CERTIFY THAT THIS PLAN WAS PREPARED BY ME OR UNDER MY DIRECT SUPERVISION AND THAT I AM A DULY LICENSED PROFESSIONAL ENGINEER UNDER THE LAWS OF THE STATE OF MINNESOTA.

PRINT NAME: CURT A. KOBILARCSIK
 SIGNATURE: *Curt A. Kobilarsik*
 DATE: 7-11-14 LICENSE NO. 24756

DRAWN BY: ZB DATE: 07-07-16
 DESIGN BY: MN DATE: 07-07-14
 CHECKED BY: CAK DATE: 07-11-14

ANOKA COUNTY
HIGHWAY DEPT.

S.A.P. 002-621-010

INTERSECTION DETAILS
 CSAH 21 AND CENTER STREET

Sheet 48 of 147 Sheets

CSAH 21 AT MEADOW LANE (WEST)

POINT	ALIGNMENT	STATION	LOCATION	ELEVATION	SLOPE % FROM - TO	DESCRIPTION
MD3	CSAH 21	144+28.91	63.31' LT	912.49	-3.43% MD3 - D14	MATCH POINT
D14	CSAH 21	144+28.91	56.50' LT	912.26	-3.43% D14 - D15	BEGIN RADIUS
D15	CSAH 21	144+19.53	33.87' LT	911.39	-3.43% D15 - D16	MIDPOINT
D16	CSAH 21	143+96.91	24.50' LT	910.53	-3.43%	END RADIUS
D17	CSAH 21	143+95.12	49.47' LT			MATCH PATH
D18	CSAH 21	144+02.40	53.42' LT			MATCH PATH
D19	CSAH 21	144+16.38	38.49' LT			PED RAMP
D20	CSAH 21	144+16.53	42/63' LT			PED RAMP
RD3	CSAH 21	143+96.91	56.53' LT			RADIUS PT
MD4	CSAH 21	144+59.82	63.30' LT	912.49		MATCH POINT
D21	CSAH 21	144+59.82	61.50' LT	912.42	-4.03% MD4 - D21	END RADIUS
D22	CSAH 21	144+69.19	38.87' LT	911.40	-4.03% D21 - D22	MIDPOINT
D23	CSAH 21	144+91.82	29.50' LT	910.39	-4.03% D22 - D23	BEGIN RADIUS
D24	CSAH 21	144+84.13	42.28' LT	911.20		SW EDGE
D25	CSAH 21	144+76.81	43.31' LT	911.54		SW EDGE
RD4	CSAH 21	144+91.84	61.46' LT			RADIUS PT

LEGEND

- 999.99 EXISTING SPOT ELEVATION
- 999.99 PROPOSED SPOT ELEVATION
- 2.00 PROPOSED LANE SLOPE (%)
- SAWCUT
- 2.00% CROSS SLOPE
- 2.50% CROSS SLOPE
- PROPOSED CATCH BASIN

ELEVATIONS ARE TOP OF FINISHED PAVEMENT

CURB AND GUTTER ELEVATIONS ARE SHOWN AT TOP OF FINISHED BITUMINOUS AT LIP OF GUTTER UNLESS OTHERWISE NOTED

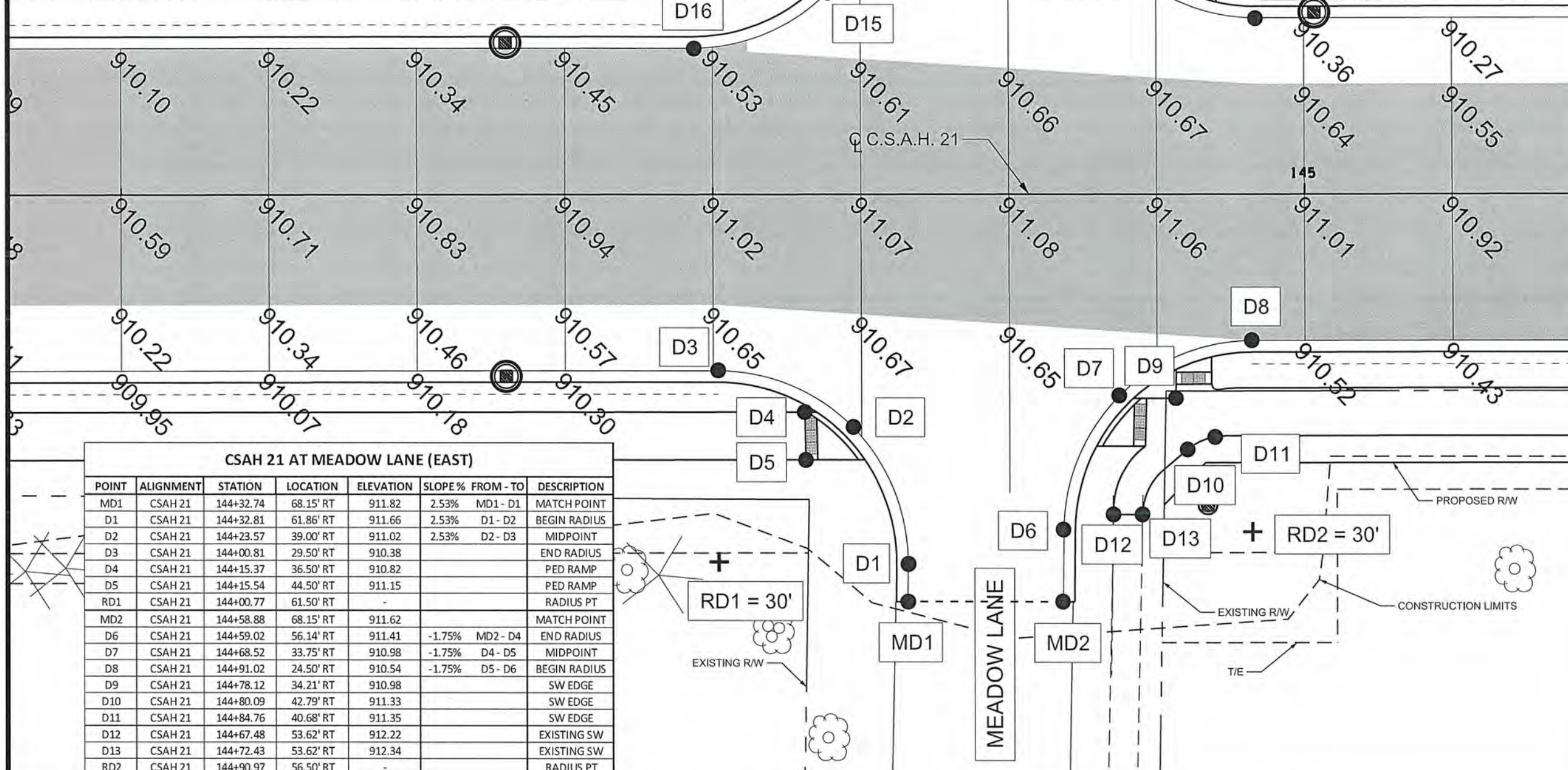

CSAH 21 AT MEADOW LANE (EAST)

POINT	ALIGNMENT	STATION	LOCATION	ELEVATION	SLOPE % FROM - TO	DESCRIPTION
MD1	CSAH 21	144+32.74	68.15' RT	911.82	2.53% MD1 - D1	MATCH POINT
D1	CSAH 21	144+32.81	61.86' RT	911.66	2.53% D1 - D2	BEGIN RADIUS
D2	CSAH 21	144+23.57	39.00' RT	911.02	2.53% D2 - D3	MIDPOINT
D3	CSAH 21	144+00.81	29.50' RT	910.38		END RADIUS
D4	CSAH 21	144+15.37	36.50' RT	910.82		PED RAMP
D5	CSAH 21	144+15.54	44.50' RT	911.15		PED RAMP
RD1	CSAH 21	144+00.77	61.50' RT			RADIUS PT
MD2	CSAH 21	144+58.88	68.15' RT	911.62		MATCH POINT
D6	CSAH 21	144+59.02	56.14' RT	911.41	-1.75% MD2 - D4	END RADIUS
D7	CSAH 21	144+68.52	33.75' RT	910.98	-1.75% D4 - D5	MIDPOINT
D8	CSAH 21	144+91.02	24.50' RT	910.54	-1.75% D5 - D6	BEGIN RADIUS
D9	CSAH 21	144+78.12	34.21' RT	910.98		SW EDGE
D10	CSAH 21	144+80.09	42.79' RT	911.33		SW EDGE
D11	CSAH 21	144+84.76	40.68' RT	911.35		SW EDGE
D12	CSAH 21	144+67.48	53.62' RT	912.22		EXISTING SW
D13	CSAH 21	144+72.43	53.62' RT	912.34		EXISTING SW
RD2	CSAH 21	144+90.97	56.50' RT			RADIUS PT

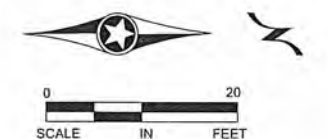

NO	DATE	BY	CKD	APPR	REVISION

I HEREBY CERTIFY THAT THIS PLAN WAS PREPARED BY ME OR UNDER MY DIRECT SUPERVISION AND THAT I AM A DULY LICENSED PROFESSIONAL ENGINEER UNDER THE LAWS OF THE STATE OF MINNESOTA.
 PRINT NAME: CURT A. KOBILARCSIK
 SIGNATURE: *[Signature]*
 DATE: 7-17-14 LICENSE NO. 24756

DRAWN BY: ZB DATE: 07-07-14
 DESIGN BY: MN DATE: 07-07-14
 CHECKED BY: CAK DATE: 07-11-14

ANOKA COUNTY
 HIGHWAY DEPT.

S.A.P. 002-621-010

INTERSECTION DETAILS
 CSAH 21 AND MEADOW LANE
 Sheet 49 of 147 Sheets

CSAH 21 AT HERITAGE STREET (WEST)

POINT	ALIGNMENT	STATION	LOCATION	ELEVATION	SLOPE % FROM - TO	DESCRIPTION
E1	CSAH 21	151+90.73	18.42' LT	907.21		BEGIN RADIUS
E2	CSAH 21	152+13.43	27.35' LT	906.56	-2.58% E1 - E2	MIDPOINT
E3	CSAH 21	152+23.15	49.85' LT	905.91	-2.58% E2 - E3	END RADIUS
ME1	CSAH 21	152+23.28	59.13' LT	905.67	-2.58% E3 - ME1	MATCH POINT
RE1	CSAH 21	151+91.32	50.41' LT	-		RADIUS PT
ME2	CSAH 21	152+48.60	58.75' LT	905.62		MATCH POINT
E4	CSAH 21	152+48.58	57.49' LT	905.65	1.89% E4 - ME2	END RADIUS
E5	CSAH 21	152+58.22	33.49' LT	905.90	1.89% E5 - E4	MIDPOINT
E6	CSAH 21	152+82.08	23.50' LT	906.65	1.89% E6 - E5	BEGIN RADIUS
RE2	CSAH 21	152+82.03	57.00' LT	-		RADIUS PT

LEGEND

- 999.99 EXISTING SPOT ELEVATION
- 999.99 PROPOSED SPOT ELEVATION
- 2.00 PROPOSED LANE SLOPE (%)
- SAWCUT
- 2.00% CROSS SLOPE
- 2.50% CROSS SLOPE
- PROPOSED CATCH BASIN / MANHOLE

ELEVATIONS ARE TOP OF FINISHED PAVEMENT

CURB AND GUTTER ELEVATIONS ARE SHOWN AT TOP OF FINISHED BITUMINOUS AT LIP OF GUTTER UNLESS OTHERWISE NOTED

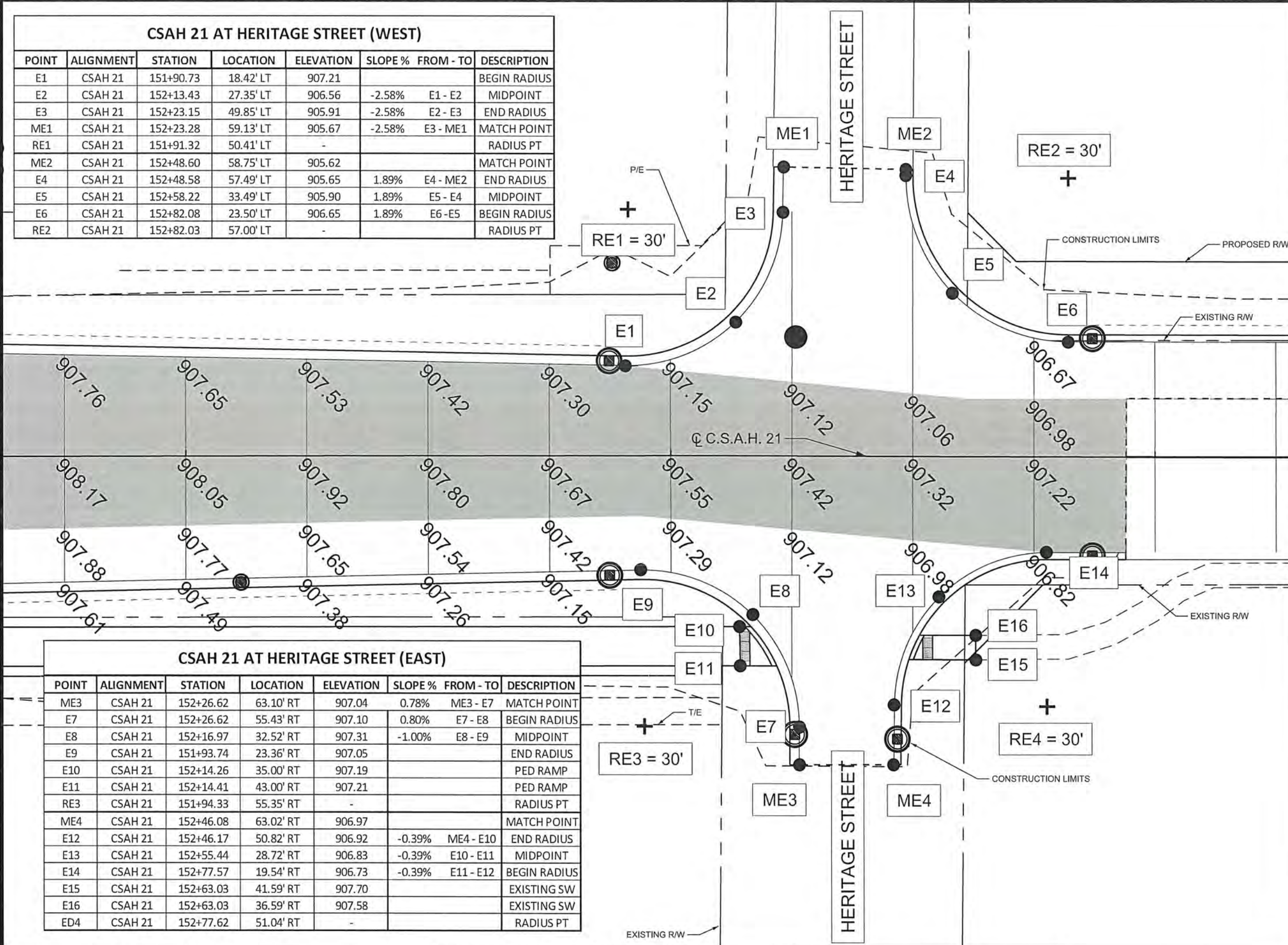

CSAH 21 AT HERITAGE STREET (EAST)

POINT	ALIGNMENT	STATION	LOCATION	ELEVATION	SLOPE % FROM - TO	DESCRIPTION
ME3	CSAH 21	152+26.62	63.10' RT	907.04	0.78% ME3 - E7	MATCH POINT
E7	CSAH 21	152+26.62	55.43' RT	907.10	0.80% E7 - E8	BEGIN RADIUS
E8	CSAH 21	152+16.97	32.52' RT	907.31	-1.00% E8 - E9	MIDPOINT
E9	CSAH 21	151+93.74	23.36' RT	907.05		END RADIUS
E10	CSAH 21	152+14.26	35.00' RT	907.19		PED RAMP
E11	CSAH 21	152+14.41	43.00' RT	907.21		PED RAMP
RE3	CSAH 21	151+94.33	55.35' RT	-		RADIUS PT
ME4	CSAH 21	152+46.08	63.02' RT	906.97		MATCH POINT
E12	CSAH 21	152+46.17	50.82' RT	906.92	-0.39% ME4 - E10	END RADIUS
E13	CSAH 21	152+55.44	28.72' RT	906.83	-0.39% E10 - E11	MIDPOINT
E14	CSAH 21	152+77.57	19.54' RT	906.73	-0.39% E11 - E12	BEGIN RADIUS
E15	CSAH 21	152+63.03	41.59' RT	907.70		EXISTING SW
E16	CSAH 21	152+63.03	36.59' RT	907.58		EXISTING SW
ED4	CSAH 21	152+77.62	51.04' RT	-		RADIUS PT

NO	DATE	BY	CKD	APPR	REVISION

I HEREBY CERTIFY THAT THIS PLAN WAS PREPARED BY ME OR UNDER MY DIRECT SUPERVISION AND THAT I AM A DULY LICENSED PROFESSIONAL ENGINEER UNDER THE LAWS OF THE STATE OF MINNESOTA.
 PRINT NAME: CURT A. KOBIARCSIK
 SIGNATURE: *[Signature]*
 DATE: 7-14-14 LICENSE NO. 24756

DRAWN BY: ZB DATE: 07-07-14
 DESIGN BY: MN DATE: 07-07-14
 CHECKED BY: CAK DATE: 07-11-14

ANOKA COUNTY
HIGHWAY DEPT.

S.A.P. 002-621-010

INTERSECTION DETAILS
 CSAH 21 AND HERITAGE ST
 Sheet 50 of 147 Sheets

CSAH 21 AT SOREL STREET (WEST)

POINT	ALIGNMENT	STATION	LOCATION	ELEVATION	SLOPE %	FROM - TO	DESCRIPTION
MF1	CSAH 21	155+72.36	53.15' LT	905.64	-0.30%	MF1 - F1	MATCH POINT
F1	CSAH 21	155+72.34	49.82' LT	905.63	-0.30%	F1 - F2	BEGIN RADIUS
F2	CSAH 21	155+64.51	31.20' LT	905.57	-0.30%	F2 - F3	MIDPOINT
F3	CSAH 21	155+45.84	23.50' LT	905.50			END RADIUS
F4	CSAH 21	155+50.10	44.40' LT	906.33			EXISTING SW
F5	CSAH 21	155+58.38	44.30' LT	906.16			EXISTING SW
RF1	CSAH 21	155+45.79	50.00' LT	-			RADIUS PT
MF2	CSAH 21	156+01.79	46.44' LT	905.69	-2.55%	MF2 - F6	MATCH POINT
F6	CSAH 21	156+00.67	35.46' LT	905.41			CATCH BASIN
MF3	CSAH 21	156+19.50	20.32' LT	906.00	-1.97%	MF3 - F6	MATCH POINT
F7	CSAH 21	156+19.50	25.17' LT	906.50			EXISTING SW

LEGEND

- 999.99 EXISTING SPOT ELEVATION
- 999.99 PROPOSED SPOT ELEVATION
- 2.00 PROPOSED LANE SLOPE (%)
- SAWCUT
- 2.50% CROSS SLOPE
- SLOPE TRANSITION
- PROPOSED CATCH BASIN

ELEVATIONS ARE TOP OF FINISHED PAVEMENT

CURB AND GUTTER ELEVATIONS ARE SHOWN AT TOP OF FINISHED BITUMINOUS AT LIP OF GUTTER UNLESS OTHERWISE NOTED

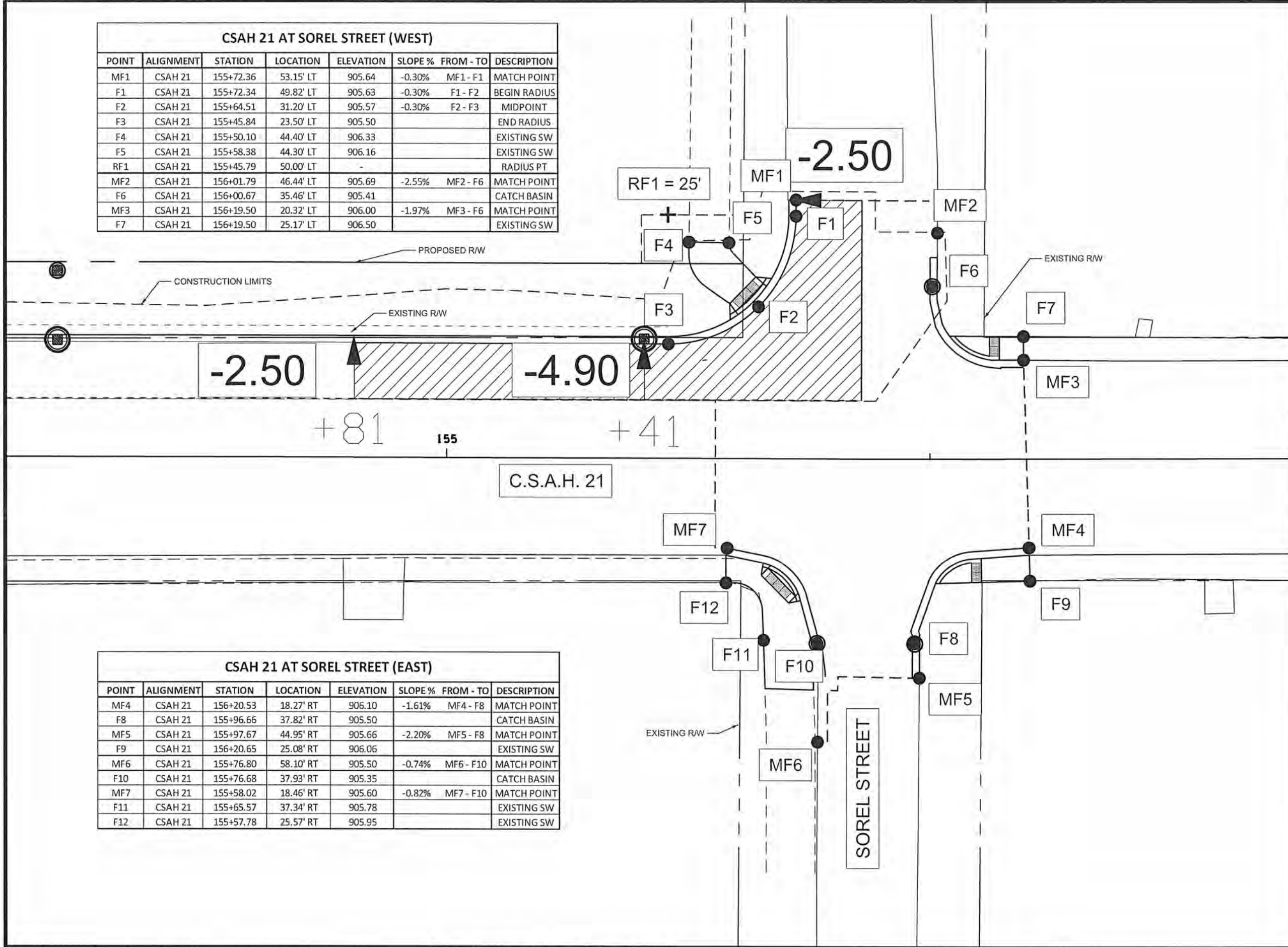

CSAH 21 AT SOREL STREET (EAST)

POINT	ALIGNMENT	STATION	LOCATION	ELEVATION	SLOPE %	FROM - TO	DESCRIPTION
MF4	CSAH 21	156+20.53	18.27' RT	906.10	-1.61%	MF4 - F8	MATCH POINT
F8	CSAH 21	155+96.66	37.82' RT	905.50			CATCH BASIN
MF5	CSAH 21	155+97.67	44.95' RT	905.66	-2.20%	MF5 - F8	MATCH POINT
F9	CSAH 21	156+20.65	25.08' RT	906.06			EXISTING SW
MF6	CSAH 21	155+76.80	58.10' RT	905.50	-0.74%	MF6 - F10	MATCH POINT
F10	CSAH 21	155+76.68	37.93' RT	905.35			CATCH BASIN
MF7	CSAH 21	155+58.02	18.46' RT	905.60	-0.82%	MF7 - F10	MATCH POINT
F11	CSAH 21	155+65.57	37.34' RT	905.78			EXISTING SW
F12	CSAH 21	155+57.78	25.57' RT	905.95			EXISTING SW

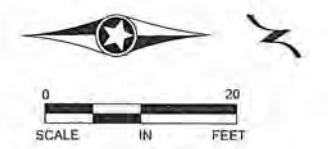

NO	DATE	BY	CKD	APPR	REVISION

I HEREBY CERTIFY THAT THIS PLAN WAS PREPARED BY ME OR UNDER MY DIRECT SUPERVISION AND THAT I AM A DULY LICENSED PROFESSIONAL ENGINEER UNDER THE LAWS OF THE STATE OF MINNESOTA.
 PRINT NAME: CURT A. KOBILARCSIK
 SIGNATURE: *[Signature]*
 DATE: 7-14-14 LICENSE NO. 24756

DRAWN BY: ZB DATE: 07-07-14
 DESIGN BY: MN DATE: 07-07-14
 CHECKED BY: CAK DATE: 07-11-14

ANOKA COUNTY
HIGHWAY DEPT.

S.A.P. 002-621-010

INTERSECTION DETAILS
 CSAH 21 AND HERITAGE ST
 Sheet 51 of 147 Sheets

LEGEND	
■	PROPOSED CATCH BASIN
●	PROPOSED MANHOLE
▼	PROPOSED APRON
→	PROPOSED STORM SEWER
- - -	INPLACE CULVERT
	PROPOSED CULVERT

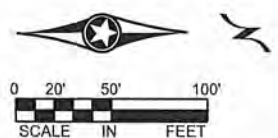
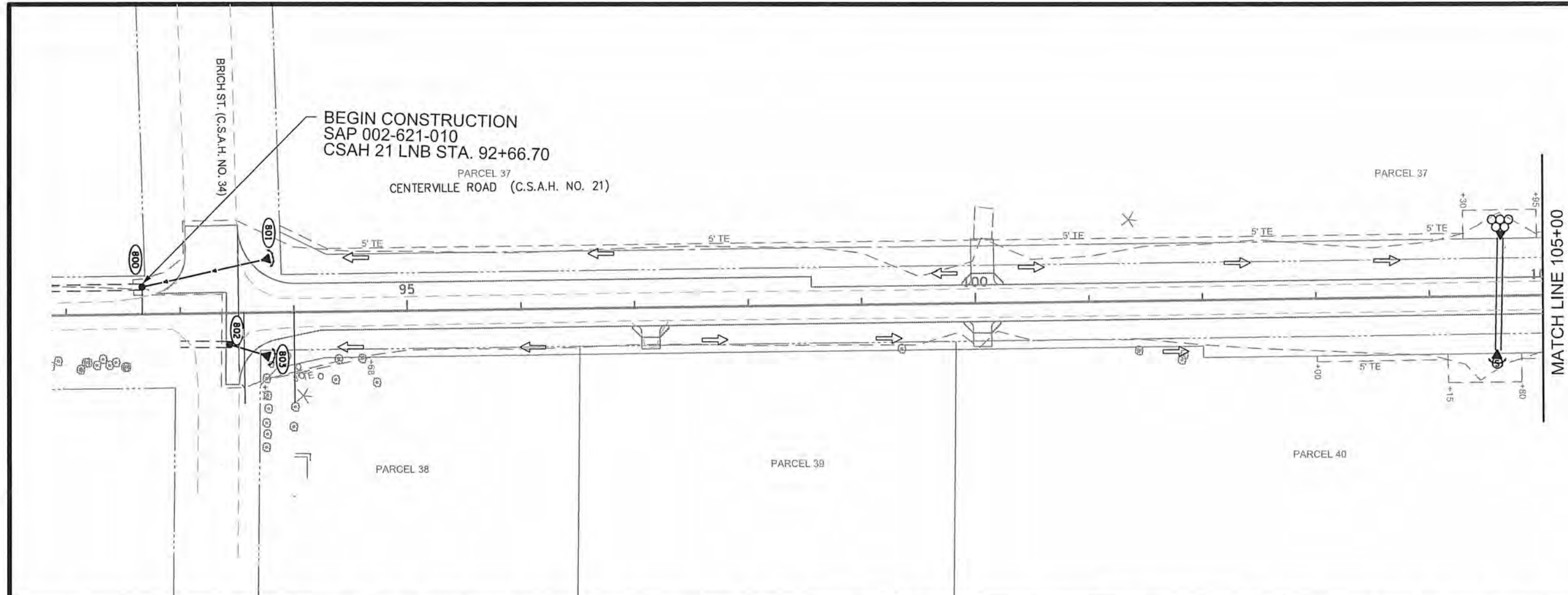

ELEVATION	STATIONING										TRAFFIC	ELEVATION																																				
	93+00	94+00	95+00	96+00	97+00	98+00	99+00	100+00	101+00	102+00																																						
920	BEGIN CONSTRUCTION SP. 002-621-010 STA. 92+66.70											920																																				
910	STA 92+66.70 FL. 907.60 STA 93+43.15 FL. 908.86 STA 93+79.30 FL. 908.55 STA 93+78.00 RT. SD. 909.70 STA 96+79.00 LT. SD. 908.76 STA 93+77.00 FL. 909.60 STA 96+75 RT. SD. 911.05 STA 97+50.00 RT. SD. 912.20 STA 98+00.00 RT. SD. 911.70 STA 98+50.00 RT. SD. 910.30 STA 99+00.00 RT. SD. 909.70 STA 99+00 SD. 909.80 STA 100+50 LT. SD. 910.00 STA 103+00 LT. SD. 906.00 STA 104+25 SD. 902.91 STA 104.56 LT. SD. 901.19 STA 54' RT 24" RCP	RT. SD. +0.4% RT. SD. +1.20% LT. SD. +0.20% RT. SD. +1.40% LT. SD. +1.6% LT. SD. +4.53%	910																																													
900	STA 92+66.70 FL. 907.60 STA 93+43.15 FL. 908.86 STA 93+79.30 FL. 908.55 STA 93+78.00 RT. SD. 909.70 STA 96+79.00 LT. SD. 908.76 STA 93+77.00 FL. 909.60 STA 96+75 RT. SD. 911.05 STA 97+50.00 RT. SD. 912.20 STA 98+00.00 RT. SD. 911.70 STA 98+50.00 RT. SD. 910.30 STA 99+00.00 RT. SD. 909.70 STA 99+00 SD. 909.80 STA 100+50 LT. SD. 910.00 STA 103+00 LT. SD. 906.00 STA 104+25 SD. 902.91 STA 104.56 LT. SD. 901.19 STA 54' RT 24" RCP	108'-24" @ 1.84% 31' -18" RCP @ 2.39% 1x18" RCP APRON	900																																													
	912.12	912.11	912.58	912.25	912.82	912.39	912.86	912.52	912.75	912.66		912.83	912.79	912.97	912.93	913.13	913.04	913.17	913.09	913.11	913.06	912.87	912.96	912.69	912.85	912.59	912.73	912.41	912.61	912.46	912.49	912.37	912.35	912.26	912.24	912.14	912.18	912.02	912.10	911.90	911.95	911.78	911.79	911.67	911.64	911.63	911.73	911.68
EXISTING ELEVATION	912.12	912.11	912.58	912.25	912.82	912.39	912.86	912.52	912.75	912.66		912.83	912.79	912.97	912.93	913.13	913.04	913.17	913.09	913.11	913.06	912.87	912.96	912.69	912.85	912.59	912.73	912.41	912.61	912.46	912.49	912.37	912.35	912.26	912.24	912.14	912.18	912.02	912.10	911.90	911.95	911.78	911.79	911.67	911.64	911.63	911.73	911.68
PROPOSED ELEVATION	912.12	912.11	912.58	912.25	912.82	912.39	912.86	912.52	912.75	912.66		912.83	912.79	912.97	912.93	913.13	913.04	913.17	913.09	913.11	913.06	912.87	912.96	912.69	912.85	912.59	912.73	912.41	912.61	912.46	912.49	912.37	912.35	912.26	912.24	912.14	912.18	912.02	912.10	911.90	911.95	911.78	911.79	911.67	911.64	911.63	911.73	911.68

1 OF 6

01	7-21-14	ZB	MN	NO LONGER SHOW EXISTING CULVERTS THAT WILL BE REMOVED
NO	DATE	BY	CKD	APPR
NAME: P:\02-621-10\Plan\0262110_PP_DR1.dgn				
	REVISION	8:11:06 AM		
	07/22/2014			

I HEREBY CERTIFY THAT THIS PLAN WAS PREPARED BY ME OR UNDER MY DIRECT SUPERVISION AND THAT I AM A DULY LICENSED PROFESSIONAL ENGINEER UNDER THE LAWS OF THE STATE OF MINNESOTA.

PRINT NAME: CURT KOBIARCSIK

SIGNATURE: *C. Kobilarcsik*

DATE: 7-22-14 LICENSE NO. 24756

DRAWN BY: ZB DATE: 07-07-14

DESIGN BY: MN DATE: 07-07-14

CHECKED BY: CAK DATE: 07-11-14

ANOKA COUNTY
HIGHWAY DEPT.

S.A.P. 002-621-010

DRAINAGE PLAN
STA 92+66.70 TO 105+00.00
Sheet 52 of 147 Sheets

LEGEND

- PROPOSED APRON
- PROPOSED CULVERT

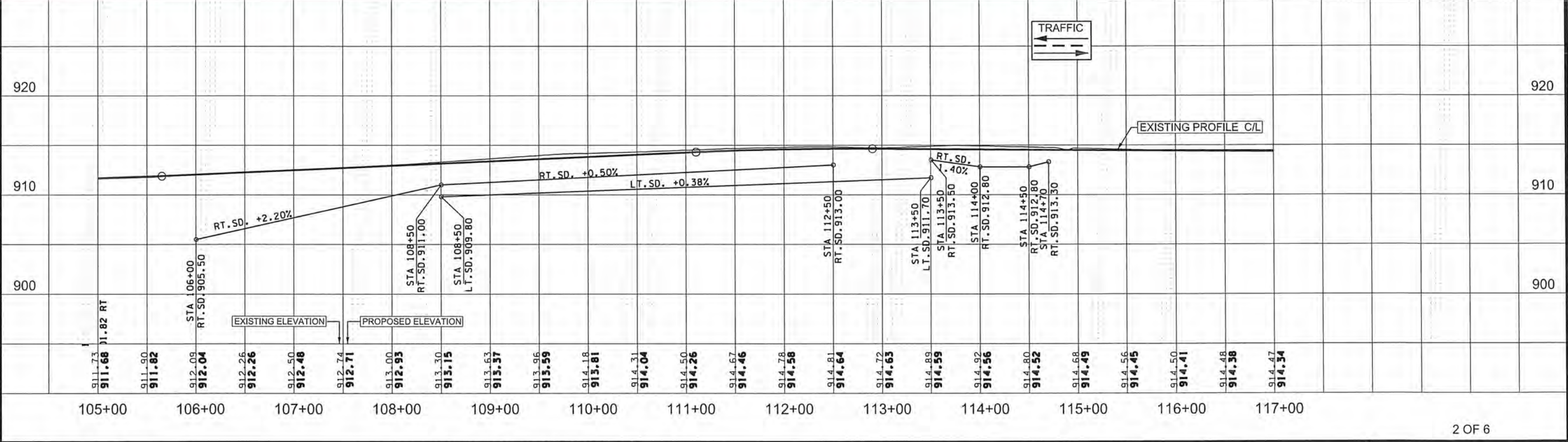
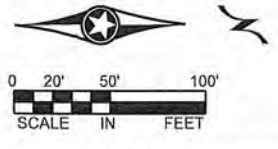
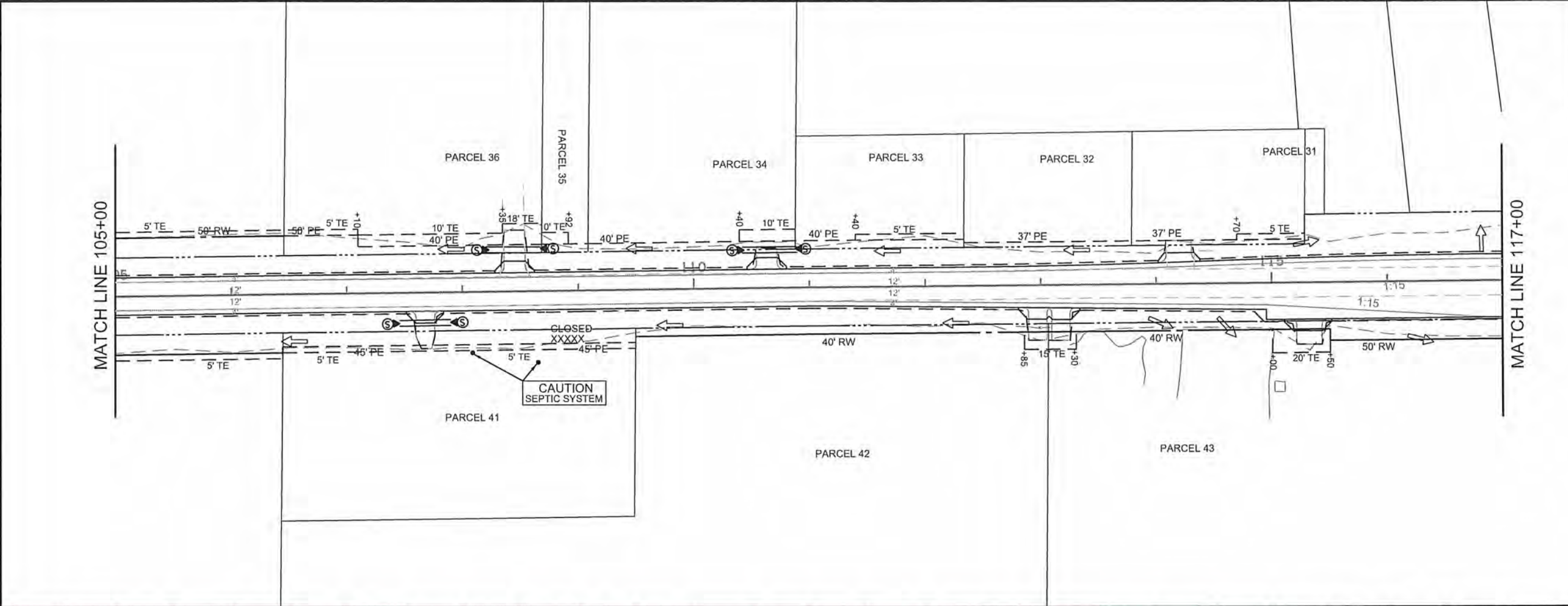

2 OF 6

01	7-21-14	ZB	MN	NO LONGER SHOW EXISTING CULVERTS
NO	DATE	BY	CKD	APPR

I HEREBY CERTIFY THAT THIS PLAN WAS PREPARED BY ME OR UNDER MY DIRECT SUPERVISION AND THAT I AM A DULY LICENSED PROFESSIONAL ENGINEER UNDER THE LAWS OF THE STATE OF MINNESOTA.
 PRINT NAME: CURT KOBILARCSIK
 SIGNATURE: *Curt Kobilarcsik*
 DATE: 7-22-14 LICENSE NO. 24756

DRAWN BY: ZB DATE: 07-07-14
 DESIGN BY: MN DATE: 07-07-14
 CHECKED BY: CAK DATE: 07-11-14

ANOKA COUNTY
HIGHWAY DEPT.

S.A.P. 002-621-010

DRAINAGE PLAN
 STA 105+00.00 TO 117+00.00
 Sheet 53 of 147 Sheets

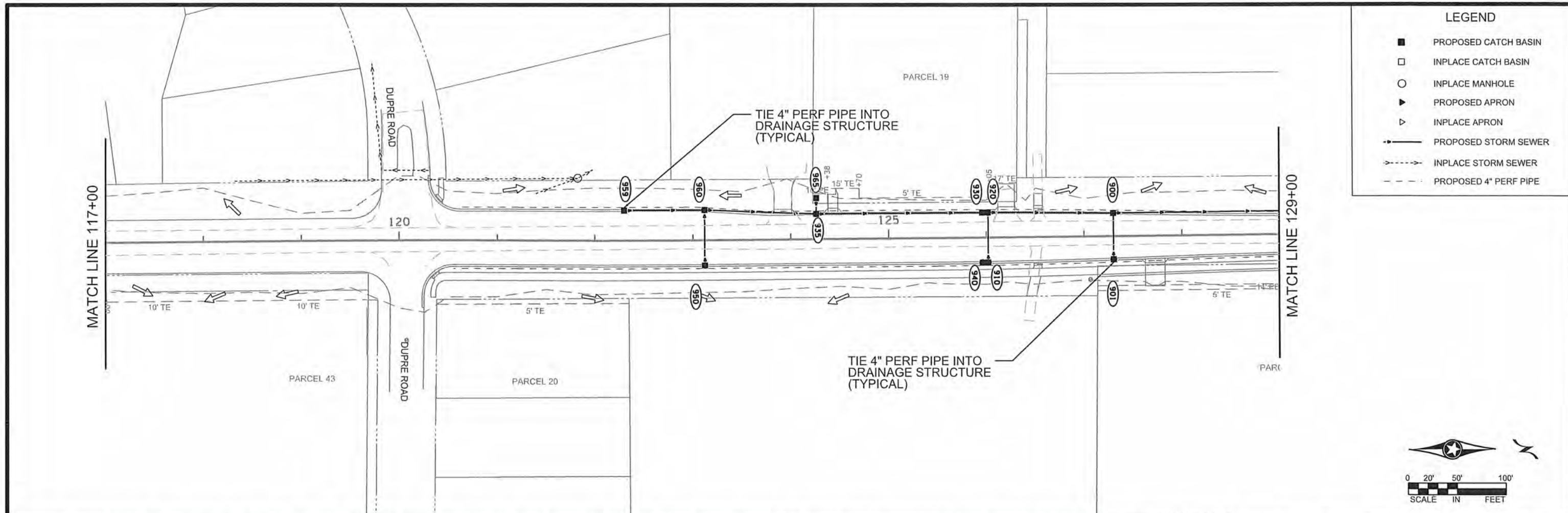

LEGEND

- PROPOSED CATCH BASIN
- INPLACE CATCH BASIN
- INPLACE MANHOLE
- ▶ PROPOSED APRON
- ▷ INPLACE APRON
- PROPOSED STORM SEWER
- - - INPLACE STORM SEWER
- - - PROPOSED 4" PERF PIPE

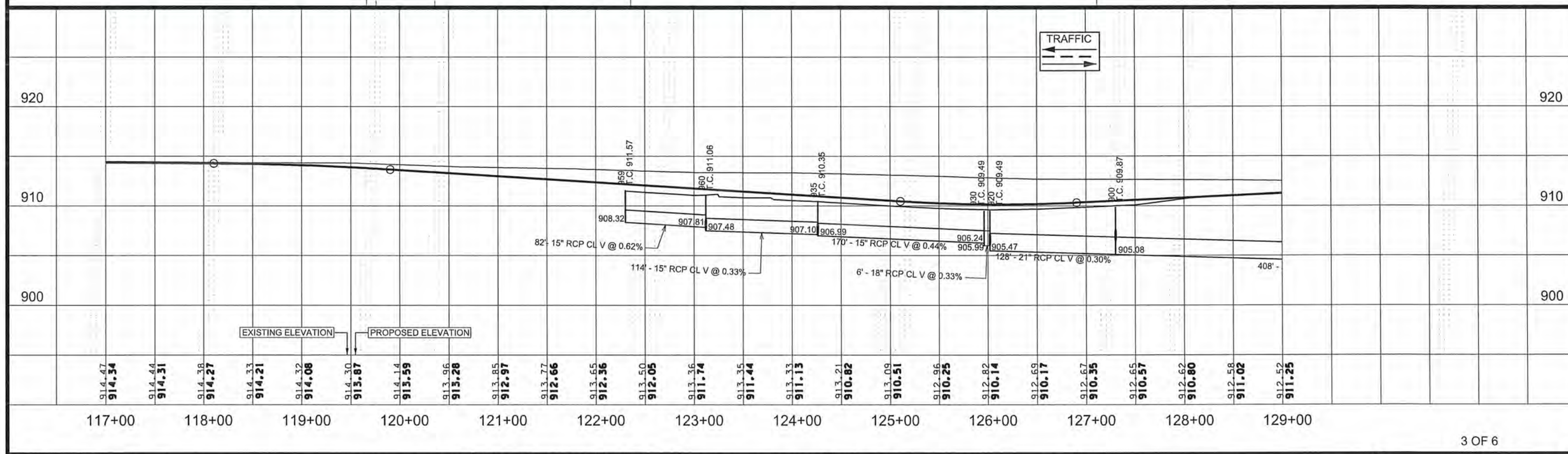
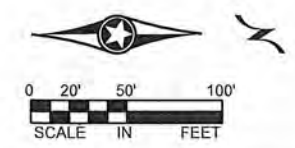

NO	DATE	BY	CKD	APPR	REVISION
01	7-21-14	ZB	MN		NO LONGER SHOW EXISTING STORM THAT WILL BE REMOVED

I HEREBY CERTIFY THAT THIS PLAN WAS PREPARED BY ME OR UNDER MY DIRECT SUPERVISION AND THAT I AM A DULY LICENSED PROFESSIONAL ENGINEER UNDER THE LAWS OF THE STATE OF MINNESOTA.
 PRINT NAME: CURT KOBILARCSIK
 SIGNATURE: *[Signature]*
 DATE: 7-22-14 LICENSE NO. 24756

DRAWN BY: ZB DATE: 07-07-14
 DESIGN BY: MN DATE: 07-07-14
 CHECKED BY: CAK DATE: 07-11-14

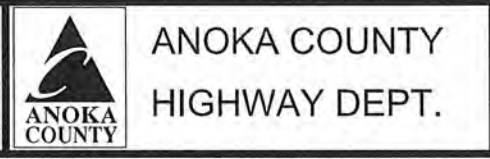

S.A.P. 002-621-010

DRAINAGE PLAN
 STA 117+00.00 TO 129+00.00
 Sheet 54 of 147 Sheets

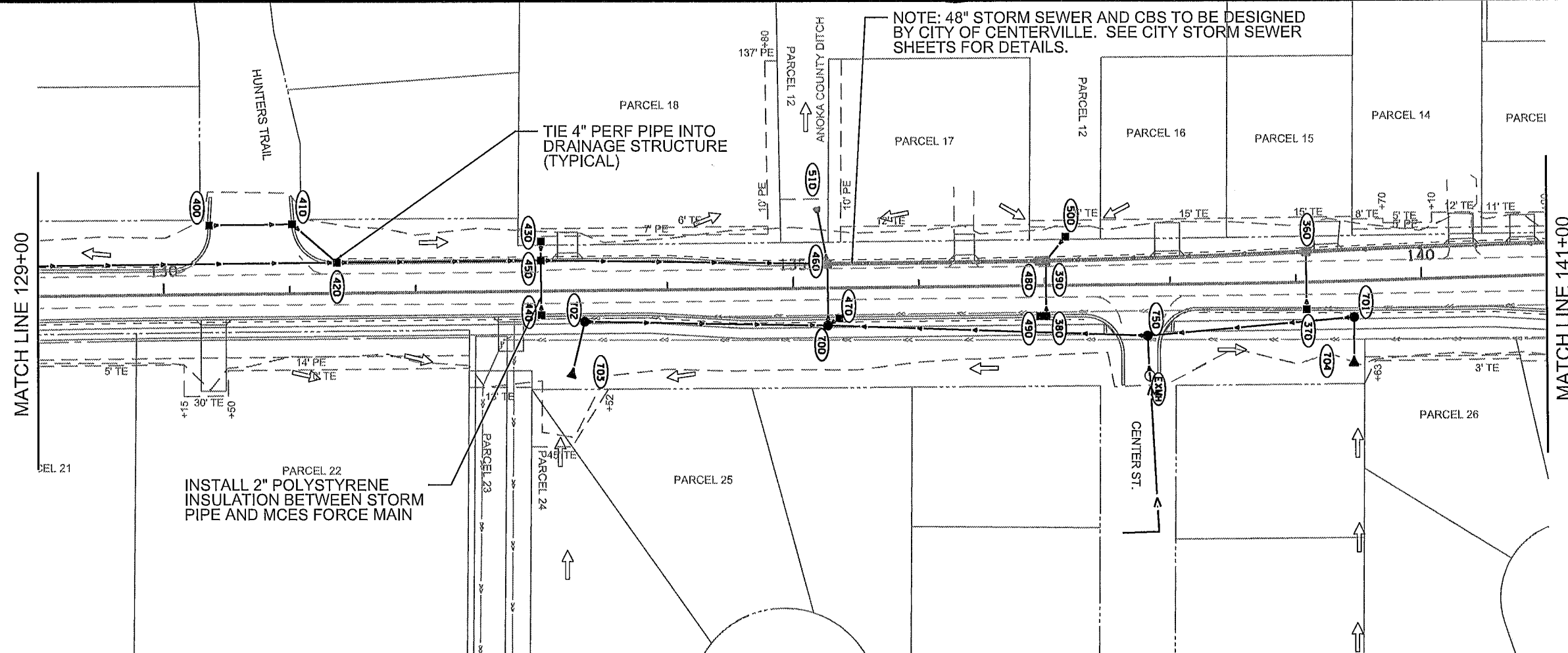

LEGEND	
■	PROPOSED CATCH BASIN
○	INPLACE MANHOLE
●	PROPOSED MANHOLE
▼	PROPOSED APRON
—	PROPOSED STORM SEWER
- - -	INPLACE STORM SEWER
- - -	PROPOSED 4" PERF PIPE
- - -	CITY DESIGNED STORM SEWER
▲	CITY DESIGNED CB/MH/APRON

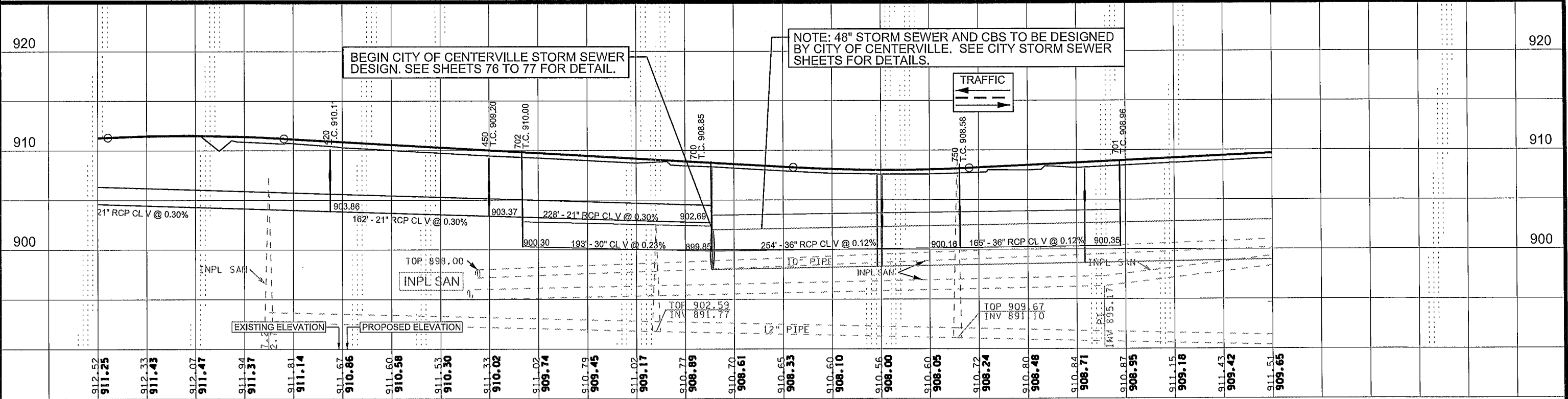
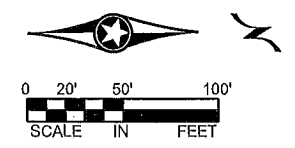

Station	Station	Station	Station	Station	Station	Station	Station	Station	Station	Station	Station	Station	Station	Station	Station	Station	Station	Station	Station
129+00	130+00	131+00	132+00	133+00	134+00	135+00	136+00	137+00	138+00	139+00	140+00	141+00							

4 OF 6

NO	DATE	BY	CKD	APPR	REVISION
01	7-21-14	ZB	MN		NO LONGER SHOW EXISTING STORM THAT WILL BE REMOVED

I HEREBY CERTIFY THAT THIS PLAN WAS PREPARED BY ME OR UNDER MY DIRECT SUPERVISION AND THAT I AM A DULY LICENSED PROFESSIONAL ENGINEER UNDER THE LAWS OF THE STATE OF MINNESOTA.
 PRINT NAME: CURT KOBILAROSIK
 SIGNATURE: *Curt Kobilarosik*
 DATE: 7-22-14 LICENSE NO. 24756

DRAWN BY: ZB DATE: 07-07-14
 DESIGN BY: MN DATE: 07-07-14
 CHECKED BY: CAK DATE: 07-11-14

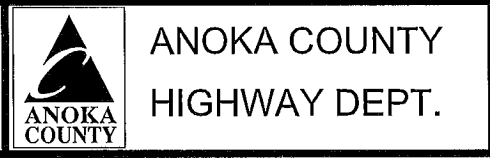

S.A.P. 002-621-010

DRAINAGE PLAN
 STA 129+00.00 TO 141+00.00
 Sheet 55 of 147 Sheets

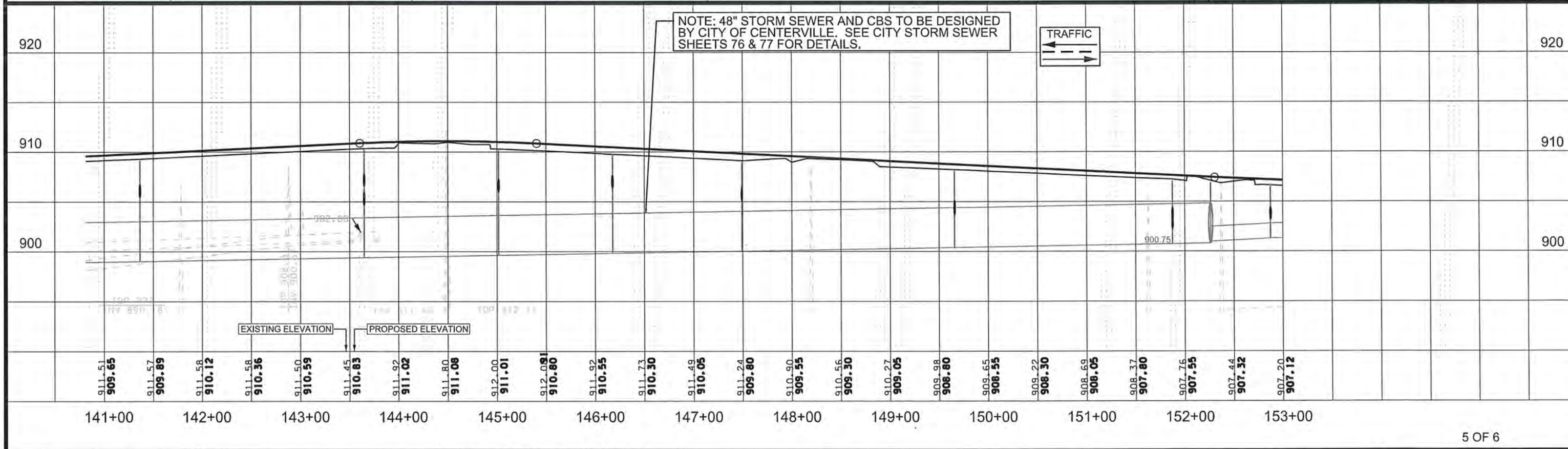
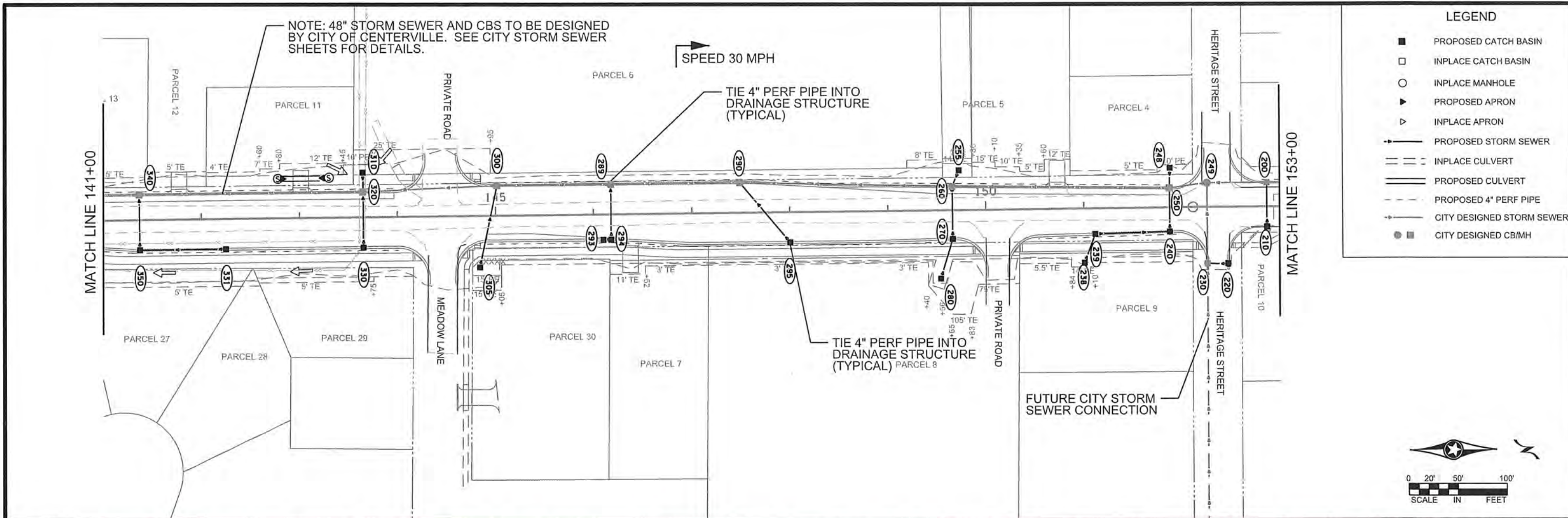

TIE 4" PERF PIPE INTO DRAINAGE STRUCTURE (TYPICAL)

END 2" BITUMINOUS OVERLAY
SP. 002-621-010
STA. 158+50.00

MATCH LINE 153+00

MAIN STREET (C.S.A.H. NO. 14)

LEGEND

- PROPOSED CATCH BASIN
- INPLACE CATCH BASIN
- PROPOSED MANHOLE
- INPLACE MANHOLE
- PROPOSED STORM SEWER
- - - INPLACE STORM SEWER
- - - PROPOSED 4" PERF PIPE
- CITY DESIGNED STORM SEWER
- CITY DESIGNED CB/MH

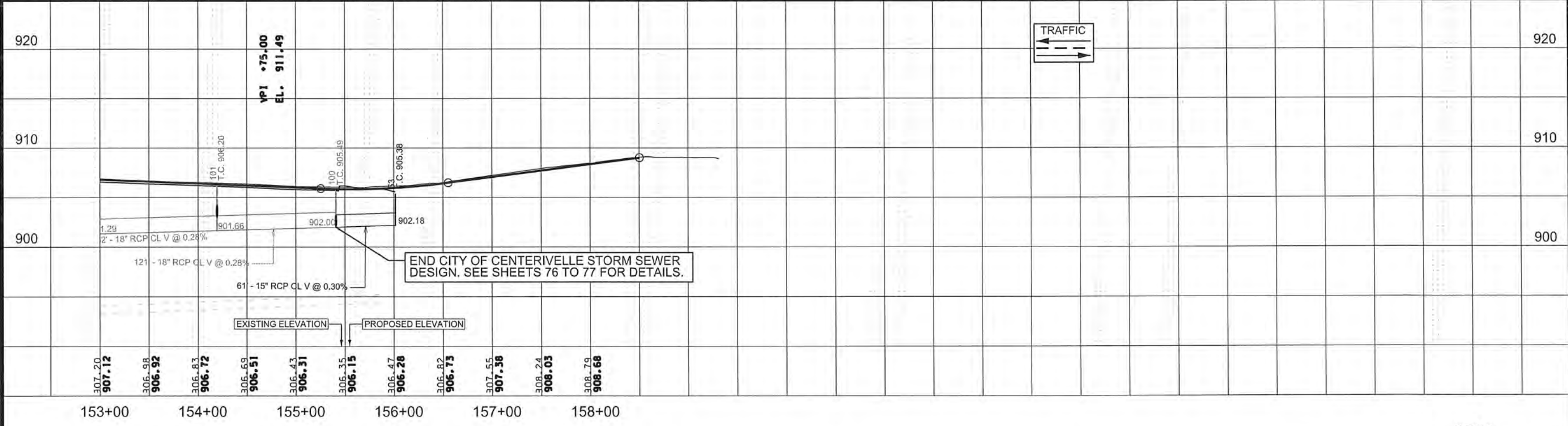
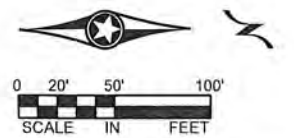

6 OF 6

NO	DATE	BY	CKD	APPR	REVISION

NAME: P:\02-621-10\Plan\0262110_PP_DR6.dgn
07/11/2014 1:38:55 PM

I HEREBY CERTIFY THAT THIS PLAN WAS PREPARED BY ME OR UNDER MY DIRECT SUPERVISION AND THAT I AM A DULY LICENSED PROFESSIONAL ENGINEER UNDER THE LAWS OF THE STATE OF MINNESOTA.

PRINT NAME: CURT KOBILARCSIK
SIGNATURE: *Curt Kobilarsik*
DATE: 7-17-14 LICENSE NO. 24756

DRAWN BY: ZB DATE: 07-07-14
DESIGN BY: MN DATE: 07-07-14
CHECKED BY: CAK DATE: 07-11-14

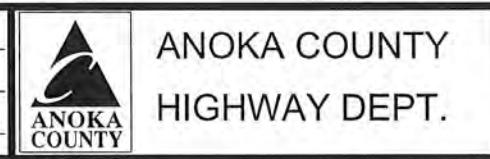

S.A.P. 002-621-010

DRAINAGE PLAN
STA 153+00.00 TO 158+50.00
Sheet 57 of 147 Sheets

DRAINAGE TAB

STRUCTURE NO.	CENTER OF CASTING						DRAINAGE STRUCTURES										STORM SEWER																		RIP RAP CL IV CY	GEOTEXTILE FABRIC TYPE IV	CONNECT TO EX STORM EACH	NOTES					
	FLOWS FROM	FLOWS TO	ALIGN	STATION	O/S	L/R	TYPE	DESIGN	PAY HEIGHT								CASTING ASSEMBLY TYPE	STEPS REQ'D	TOP OF CASTING ELEVATION	OUTLET ELEVATION	DOWN STREAM INLET	SLOPE %	PIPE SIZE	12" RCP CL V LIN FT	15" RCP CL V LIN FT	16" RCP CL III LIN FT	18" RCP APRON EACH	21" RCP CL III LIN FT	24" RCP CL III LIN FT	24" RCP APRON EACH	30" RCP CL III LIN FT	30" RCP APRON EACH	36" RCP CL III LIN FT	36" RCP APRON EACH					42" RCP CL III LIN FT	42" RCP APRON EACH	48" RCP CL III LIN FT	54" RCP CL III LIN FT	54" RCP APRON EACH
									H LIN FT	48-4020 LIN FT	54-4020 LIN FT	60-4020 LIN FT	66-4020 LIN FT	72-4020 LIN FT	78-4020 LIN FT	96-4020 LIN FT																											
700	460	CL_21	135+27.50	29.50	R	MH	95-4020																																				
701	750	CL_21	139+45.70	26.30	R	MH	60-4020				8.55																																
702	700	CL_21	133+34.20	24.50	R	MH	60-4020				9.65																																
703	702	CL_21	133+23.10	88.50	R	APRON																																					
704	701	CL_21	139+45.70	66.20	R	APRON																																					
750	700	CL_21	137+81.65	40.30	R	MH	60-4020				8.37																																
900	420	CL_21	127+30.00	23.30	L	CB	48-4020		4.74																																		
901	900	CL_21	127+30.00	23.40	R	CB	H	3.20																																			
910	920	CL_21	126+02.00	25.30	R	CB	48-4020			3.21																																	
920	900	CL_21	126+02.00	25.20	L	CB	48-4020			3.97																																	
930	920	CL_21	125+96.00	25.20	L	CB	48-4020			3.45																																	
935	930	CL_21	124+26.15	25.50	L	CB	48-4020			3.31																																	
940	910	CL_21	125+96.00	25.30	R	CB	H	3.20																																			
950	980	CL_21	123+12.00	25.50	R	CB	H	3.20																																			
959	990	CL_21	122+30.00	30.50	L	CB	H	3.20																																			
960	935	CL_21	123+12.00	30.50	L	CB	48-4020		3.53																																		
965	935	CL_21	124+26.50	41.50	L	BH	H	2.28																																			
EXMH	750	CL_21	137+83.00	71.74	R	MH																																					
800	OUTLET	CL_21	92+66.80	23.75	L	MH	48-4020		3.60																																		
801	800	CL_21	93+73.50	54.00	L	APRON																																					
802	OUTLET	CL_21	93+43.15	27.40	R	MH	48-4020		3.31																																		
803	802	CL_21	93+79.30	38.60	R	APRON																																					
PROJECT TOTAL								80.54	82.52	3.44	26.58	4.51	74.91	13.94	8.95	16.12	9.13	66						31	1803	352	1	926	108	1	238	1	457	1	49	1	1780	42	1	62	74	4	

- NOTES:
- (1) EX MH TO BE REMOVED. CONNECT TO EXISTING PIPE AND EXTEND TO PROPOSED MH 750
 - (2) STA. 91+25.11 TO 92+66.80, FURNISH AND INSTALL 144" PVC BY ANOKA COUNTY HIGHWAY DEPARTMENT
 - (3) 4" CASTING TO BE USED INSTEAD OF AN 8" CASTING
 - (4) DESIGNED BY CITY OF CENTERVILLE. FOR MORE INFORMATION SEE CITY STORM SEWER SHEETS 76 TO 77

- GENERAL NOTES:
- 1. R-3448C NEENAH CASTING ASSEMBLIES OR EAST JORDAN IRON WORKS PRODUCT NO. 00500050C01 OR APPROVED EQUALS.
 - 2. STATION AND OFFSET FOR EACH STRUCTURE GIVEN AT CENTER OF GRATE/CASTING FOR CATCH BASINS AND MANHOLES, AND AT APRON END FOR APRONS. INVERT ELEVATIONS GIVEN AT CENTER OF STRUCTURE OR END OF APRON.
 - 3. IF STEPS REQUIRED, STRUCTURE TO INCLUDE MANHOLE STEPS 16" ON CENTER. SEE MN/DOT STANDARD PLATE 4180.
 - 4. PIPE LENGTH DOES NOT INCLUDE APRON.
 - 5. THE LAST THREE JOINTS AT APRON END. FURNISHING AND INSTALLING PIPE TIES SHALL BE CONSIDERED INCIDENTAL. SEE MN/DOT STANDARD PLATE 3145.

I HEREBY CERTIFY THAT THIS PLAN WAS PREPARED BY ME OR UNDER MY DIRECT SUPERVISION AND THAT I AM A DULY LICENSED PROFESSIONAL ENGINEER UNDER THE LAWS OF THE STATE OF MINNESOTA. PRINT NAME: CURT A. KOBILARCSIK SIGNATURE: <i>Curt A. Kobilarsik</i> DATE: 7-14-14 LICENSE NO. 24756					DRAWN BY: ZB DATE: 07-07-14 DESIGN BY: MN DATE: 07-07-14 CHECKED BY: CAK DATE: 07-11-14	 ANOKA COUNTY HIGHWAY DEPT.	S.A.P. 002-621-010 DRAINAGE TABULATIONS	Sheet <u>59</u> of <u>147</u> Sheets		
NO	DATE	BY	CKD	APPR	REVISION					
NAME: P:\02-621-10\Plan\0262110_DR_TABS.dgn					07/11/2014	1:39:03 PM				

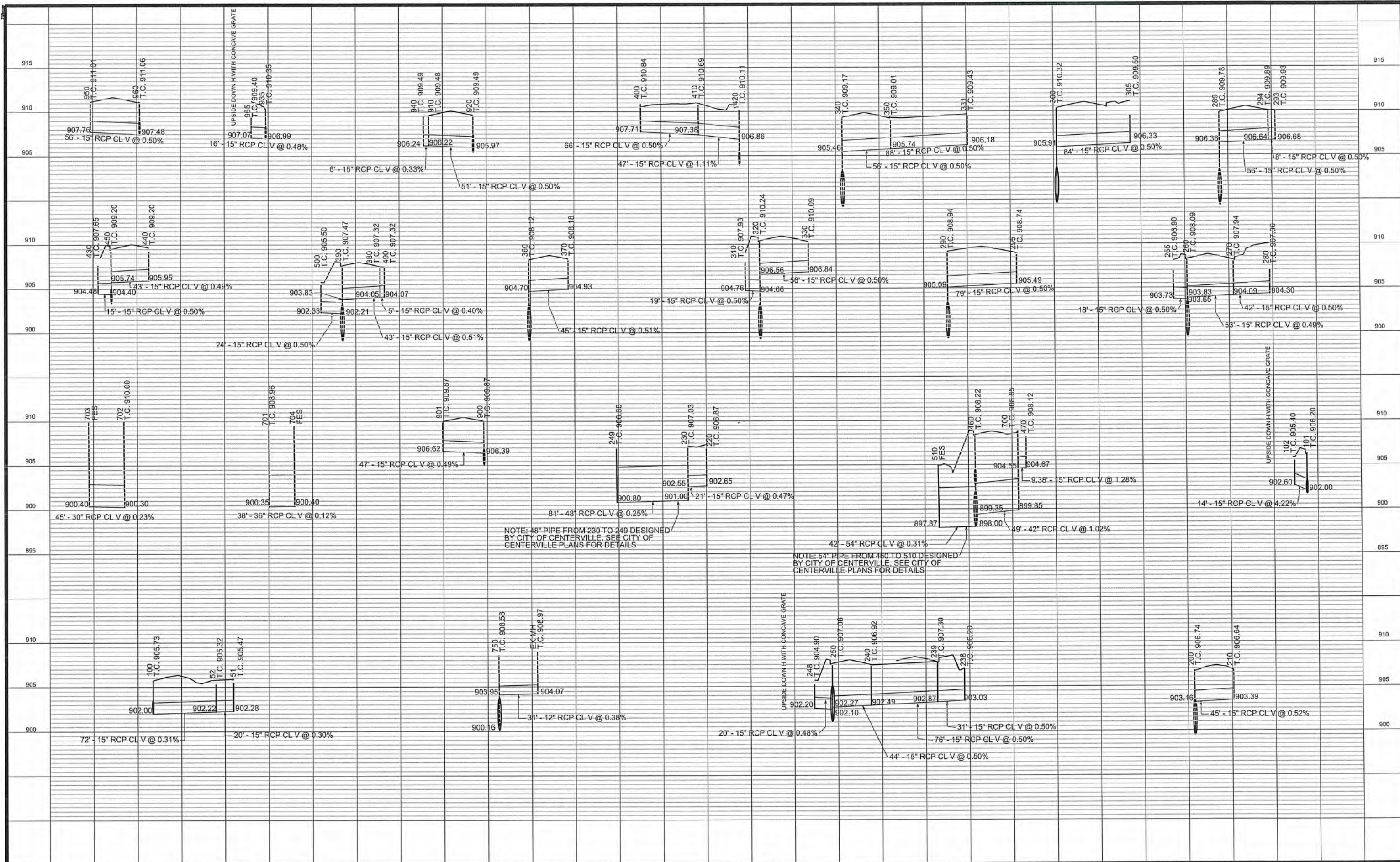

NOTE: 48" PIPE FROM 230 TO 249 DESIGNED BY CITY OF CENTERVILLE. SEE CITY OF CENTERVILLE PLANS FOR DETAILS

NOTE: 54" PIPE FROM 460 TO 510 DESIGNED BY CITY OF CENTERVILLE. SEE CITY OF CENTERVILLE PLANS FOR DETAILS

01	7-21-14	ZB	MN	CITY OF CENTERVILLE STORM SEWER
NO	DATE	BY	CKD	APPR
NAME: P:\02-621-10\Plan\0262110_DR_LEADS.dgn				07/21/2014 10:58:04 AM

I HEREBY CERTIFY THAT THIS PLAN WAS PREPARED BY ME OR UNDER MY DIRECT SUPERVISION AND THAT I AM A DULY LICENSED PROFESSIONAL ENGINEER UNDER THE LAWS OF THE STATE OF MINNESOTA.
 PRINT NAME: CURT A. KOBIARCSIK
 SIGNATURE: *Curt Kobilarcsik*
 DATE: 7-22-14 LICENSE NO. 24756

DRAWN BY: ZB DATE: 07-07-14
 DESIGN BY: MN DATE: 07-07-14
 CHECKED BY: CAK DATE: 07-11-14

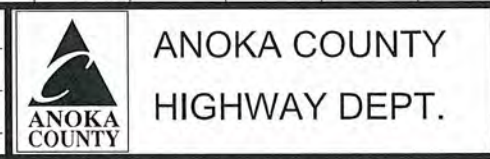

S.A.P. 002-621-010

FRAME RING AND CASTING TYPE A
 FRAME RING AND CASTING TYPE B
 TO BE USED FOR MEDIAN CATCH BASINS

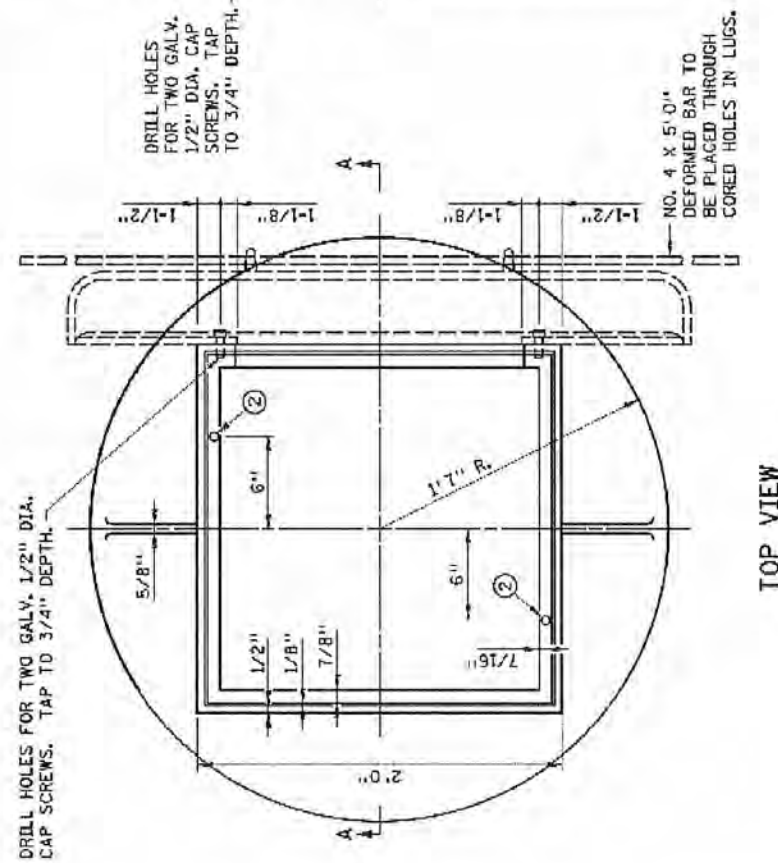
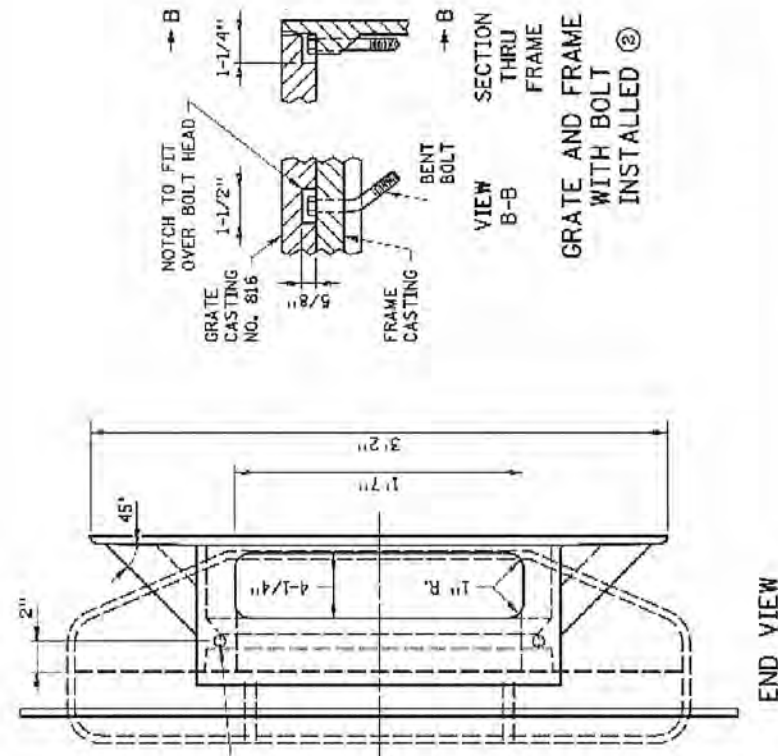

CASTINGS USED FOR ASSEMBLY
 GRATE NO. 816 (MNDOT STD PLATE 4154B)
 CURB BOX ① NO. 823A (MNDOT STD PLATE 416D) OR

NOTES:
 ① USE 1/4" FILLETS IN ALL CORNERS. SEE MNDOT STANDARD PLATE 7111 FOR INSTALLATION REQUIREMENTS.
 ② APPLIES TO DESIGN B OR V CURB AND CURB AND CUTTER.
 ③ AT LOCATIONS INDICATED IN TOP VIEW, PROVIDE 3/16" DIA. HOLES WHEN GRATE NO. 816 (MNDOT STD PLATE 4154B) IS USED WITH THIS FRAME. FIELD PLACE 1/2" DIA X 4" LONG GALV BOLT IN UP STREAM SIDE AND BENT UNDERSIDE TO PREVENT REMOVAL. THIS WILL PREVENT GRATE NO. 816 (MNDOT STD PLATE 4154) FROM BEING PLACED IN WRONG AND NOT BEING BICYCLE SAFE

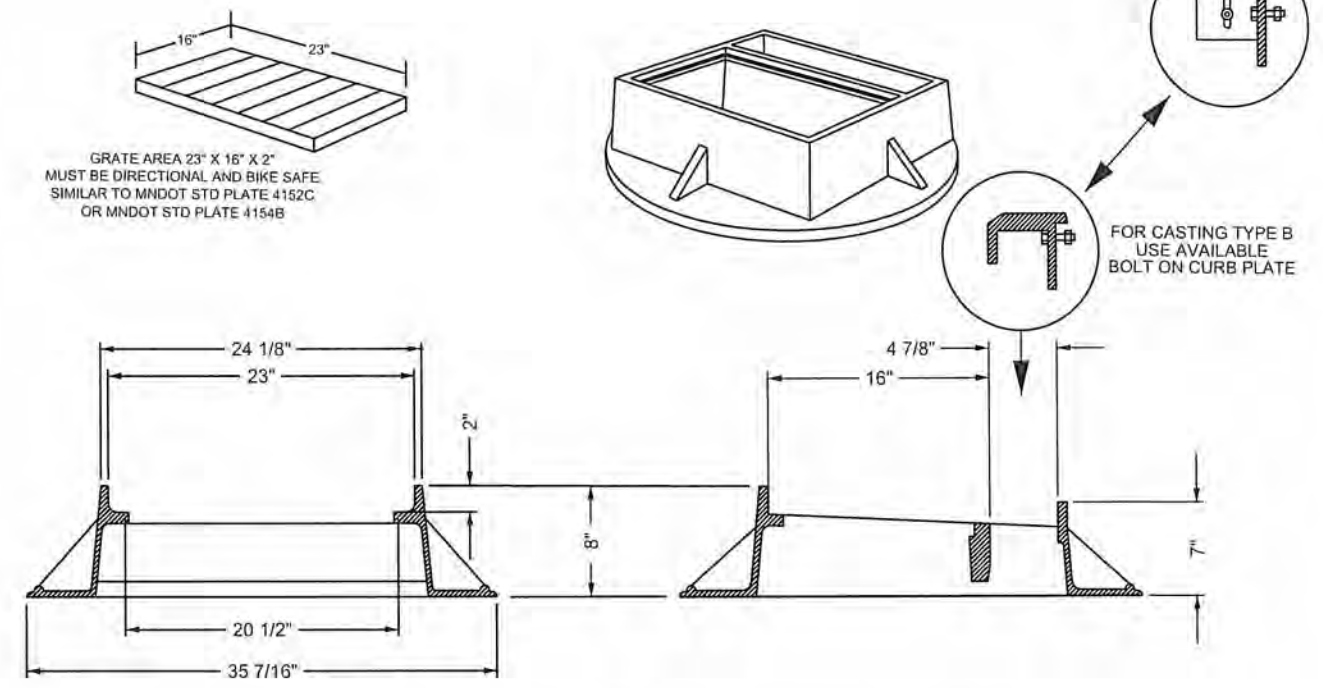
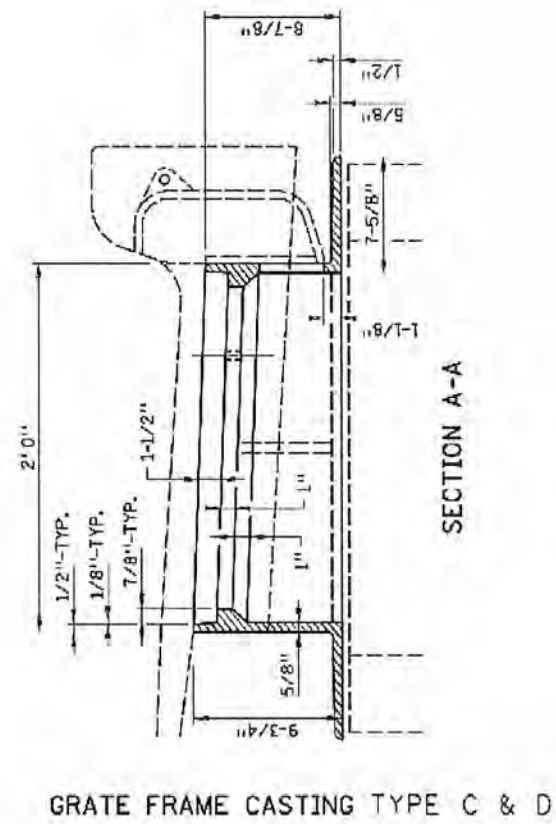

FOR FRAME CASTING FOR TYPE E & F SEE MNDOT STD PLATE 4101D
 FOR GRATE CASTING TYPE E SEE S MNDOT STD PLATE 4140D "CONCAVE"
 FOR GRATE CASTING TYPE F SEE S MNDOT STD PLATE 4110F
 FOR FRAME CASTING FOR TYPE G SEE MNDOT STD PLATE 4126F
 SEE MNDOT STD PLATE 4161F FOR CURB BOX ON G TYPE CASTING
 FOR TYPE G CASTINGS USE GRATE NO 810 - MNDOT STD PLATE 4149C

CASTING ASSEMBLY TYPE	ASSUMED CASTING HEIGHT [FT]	DESCRIPTION	TYPE
A	0.75	18' GRATE WITH CURB BOX	CB
B	0.75	18" GRATE WITH COVER PLATE	CB
C	0.75	24" GRATE WITH CURB BOX	CB
D	0.75	24" GRATE WITH COVER PLATE	CB
E	0.33	BEEHIVE	BH
F	0.75	MANHOLE	MH
G	0.87	ROUND CASTING & GRATE	CB
N/A	N/A	APRON	APRON

NO	DATE	BY	CKD	APPR	REVISION

NAME: P:\02-621-10\Plan\0262110_DR_DET.dgn 07/11/2014 1:39:10 PM

I HEREBY CERTIFY THAT THIS PLAN WAS PREPARED BY ME OR UNDER MY DIRECT SUPERVISION AND THAT I AM A DULY LICENSED PROFESSIONAL ENGINEER UNDER THE LAWS OF THE STATE OF MINNESOTA.

PRINT NAME: CURT A. KOBLARCSIK
 SIGNATURE: *Curt Koblarcsik*
 DATE: 7-14-14 LICENSE NO. 24756

DRAWN BY: ZR DATE: 07-07-14
 DESIGN BY: MN DATE: 07-07-14
 CHECKED BY: CAK DATE: 07-11-14

ANOKA COUNTY
 HIGHWAY DEPT.

S.A.P. 002-621-010

DRAINAGE DETAILS
 Sheet 61 of 147 Sheets

STORM WATER POLLUTION PREVENTION PLAN (SWPPP)

PROJECT LOCATION AND GENERAL INFORMATION

SAP 002-621-010 IS LOCATED AT CSAH 21 (CENTERVILLE RD.) BETWEEN CSAH 34 (BRICH ST.) TO SOREL ST. (APPROX 320' SO. MAIN ST.) IN THE CITY OF LINO LAKES AND THE CITY OF CENTERVILLE.

THE PROPOSED PROJECT WILL INCLUDE RIGHT TURN LANES, 4 FT PAVED SHOULDER, CURB & GUTTER, STORM SEWER AND DRAINAGE DITCHES. THE RECEIVING WATERS WILL DRAIN TO TWO PLACES. THE MAJORITY WILL FLOW THROUGH THE STORM SEWER INTO A COUNTY DITCH, WHERE IT WILL THEN FLOW TO A CITY OF CENTERVILLE POND, AND FINALLY TO CENTERVILLE LAKE TO THE NORTHWEST OF THE PROJECT. THE REMAINING RECEIVING WATERS WILL FLOW THROUGH ROAD SIDE DITCHES AND CULVERTS TO THE SOUTH OF THE PROJECT.

THIS PROJECT WILL IMPACT 13.01 ACRES OF SOILS AND CREATE POTENTIAL FOR SEDIMENT DISCHARGE FROM THE SITE.

TRAINING REQUIREMENTS

THE CONTRACTOR SHALL ENSURE COMPLIANCE WITH THE TRAINING REQUIRED IN PART 111.A.2 OF THE GENERAL STORM WATER PERMIT FOR CONSTRUCTION ACTIVITY.

THE INDIVIDUALS TRAINED AND THE TRAINING RECEIVED SHALL BE RECORDED IN THE SWPPP BEFORE THE START OF CONSTRUCTION OR AS SOON AS PERSONNEL FOR THE PROJECT HAVE BEEN DETERMINED.

LONG TERM OPERATION AND MAINTENANCE

THE STREETS DIVISION OF CITY CENTERVILLE SHALL BE RESPONSIBLE FOR THE LONG TERM OPERATION AND MAINTENANCE OF PERMANENT STORM WATER MANAGEMENT.

RECEIVING SURFACE WATERS, DISCHARGE TO IMPAIRED WATERS & SPECIAL WATERS

THE FOLLOWING TABLE IDENTIFIES ALL SURFACE WATERS WITHIN 1 MILE OF THE PROJECT BOUNDARY, WHICH WILL RECEIVE STORM WATER RUNOFF FROM THE CONSTRUCTION SITE, DURING AND AFTER CONSTRUCTION.

RECEIVING SURFACE WATERS		
NAME OF WATER BODY	SPECIAL WATER	IMPAIRED WATER
CENTERVILLE LAKE	NO	NO

STORM WATER FROM A DISCHARGE POINT ON THE PROJECT WHICH FLOWS TO A SURFACE WATER IDENTIFIED AS IMPAIRED AND/OR SPECIAL MUST INCLUDE THE FOLLOWING ADDITIONAL BMP REQUIREMENTS:

- 1) ALL EXPOSED SOILS MUST BE STABILIZED AS SOON AS POSSIBLE TO LIMIT SOIL EROSION BUT IN NO CASE LATER THAN SEVEN (7) DAYS AFTER THE CONSTRUCTION ACTIVITY IN THAT PORTION OF THE SITE HAS TEMPORARILY OR PERMANENTLY CEASED.
- 2) TEMPORARY SEDIMENT BASINS MUST BE USED FOR COMMON DRAINAGE LOCATIONS THAT SERVE AN AREA WITH FIVE (5) OR MORE ACRES DISTURBED AT ONE TIME. THIS PROJECT AS DESIGNED DOES NOT HAVE FIVE (5) DISTURBED ACRES DRAINING TO A COMMON LOCATION AND TEMPORARY SEDIMENT BASINS WILL NOT BE REQUIRED.

DISTURBED AREA

TOTAL PROJECT AREA DISTURBED : 13.01 ACRES
 EXISTING IMPERVIOUS AREA : 4.17 ACRES
 PROPOSED IMPERVIOUS AREA : 7.98 ACRES

CONSTRUCTION PHASING

SILT FENCE AND/OR OTHER SUITABLE PERIMETER BMPS AS PROVIDED IN THE PLANS WILL BE INSTALLED PRIOR TO THE START OF ANY LAND DISTURBING ACTIVITY. CONSTRUCTION WILL BE REQUIRED TO BE PHASED SO THAT ALL DOWN GRADIENT SEDIMENT CONTROL MEASURES ARE INSTALLED PRIOR TO OR IN CONJUNCTION WITH ANY SOIL DISTURBING ACTIVITIES.

WHEN TOPSOIL IS DISTURBED, THE TOPSOIL SHALL BE STRIPPED AND STOCKPILED IN SOIL BERMS AT THE TOE OF THE STRIPPED SLOPES ALONG THE PROJECT LIMITS. TEMPORARY VEGETATION WILL BE ESTABLISHED ON THE STOCKPILED TOPSOIL BERMS WITH HYDROMULCH AS NEEDED. STOCKPILED TOPSOIL BERMS SHALL NOT BE PLACED IN ANY STORM WATER CONVEYANCES.

AFTER STRIPPING THE TOPSOIL THE EXPOSED SOIL IN SLOPES SHALL BE STABILIZED WITH DISK ANCHORED TYPE 1 MULCH WITHIN 14 DAYS, AFTER THE CONSTRUCTION ACTIVITY IN THAT PROTION OF THE SITE HAS BEEN TEMPORARILY OR PERMANENTLY CEASED.

TEMPORARY SEDIMENT BASIN

THIS ROAD CONSTRUCTION PROJECT AS DESIGNED DOES NOT MEET ANY OF THE TEMPORARY SEDIMENT BASIN DISTURBED AREA THRESHOLD REQUIREMENTS AND TEMPORARY SEDIMENT BASIN WILL NOT BE REQUIRED.

PERMANENT STORM WATER MANAGEMENT SYSTEM

ALL STORM WATER MUST BE DISCHARGED IN A MANNER THAT DOES NOT CAUSE NUISANCE CONDITIONS, EROSION IN RECEIVING WATERS OR ON DOWNSLOPE PROPERTIES, OR INUNDATION IN WETLANDS CAUSING A SIGNIFICANT ADVERSE IMPACT TO THE WETLAND.

THIS ROAD CONSTRUCTION PROJECT HAS AN INCREASE OF THREE ACRES IN IMPERVIOUS AREA.

EROSION PREVENTION PRACTICES

ALL EXPOSED SOIL AREAS MUST BE STABILIZED AS SOON AS POSSIBLE TO LIMIT SOIL EROSION BUT IN NO CASE LATER THAN 14 DAYS AFTER THE CONSTRUCTION ACTIVITY IN THAT PORTION OF THE SITE HAS TEMPORARILY OR PERMANENTLY CEASED. FOR ALL AREAS WHERE DISTURBED SOILS DRAIN TO AN IMPAIRED OR SPECIAL WATERS, THE EXPOSED SOIL MUST BE STABILIZED NO LATER THAN 7 DAYS AFTER THE CONSTRUCTION ACTIVITY IN THAT AREA CEASED. SEE THE IMPAIRED & SPECIAL WATERS SECTION OF THIS SWPPP FOR ADDITIONAL BMP REQUIREMENTS FOR DISTURBED AREAS THAT DRAIN TO A SPECIAL OR IMPAIRED WATER.

THE NORMAL WETTED PERIMETER OF ANY TEMPORARY OR PERMANENT DRAINAGE DITCH OR SWALE THAT DRAIN WATER FROM ANY PORTION OF THE CONSTRUCTION SITE, OR DIVERTS WATER AROUND THE SITE, MUST BE STABILIZED WITHIN 200 LINEAL FEET FROM THE POINT OF DISCHARGE INTO ANY SURFACE WATER. STABILIZATION OF THE LAST 200 FEET MUST BE COMPLETED WITHIN 24 HOURS AFTER CONNECTING TO A SURFACE WATER.

PIPE CULVERT OUTLETS MUST BE PROVIDED WITH TEMPORARY OR PERMANENT ENERGY DISSIPATION WITHIN 24 HOURS AFTER CONNECTION TO A SURFACE WATER. THIS WILL INCLUDE DRAINAGE DITCHES THAT DRAIN WATER FROM ANY PORTION OF THE CONSTRUCTION SITE.

POLLUTION PREVENTION MEASURES

THE CONTRACTOR SHALL IMPLEMENT THE POLLUTION PREVENTION MANAGEMENT MEASURES AS DIRECTED IN THE NPDES PERMIT PART IV.F AS PERTAINING TO SOLID WASTE, HAZARDOUS MATERIALS, EXTERNAL TRUCK WASHING, AND CONCRETE WASHOUT ONSITE.

THESE MANAGEMENT MEASURE FOR POLLUTION PREVENTION SHALL BE STRICTLY ENFORCED.

PROJECT CONTACTS

DNR	NOT REQUIRED		
COE	NOT REQUIRED		
ANOKA COUNTY DESIGN SWPPP PREPARATION	U OF M DESIGN OF SWPPP EXPIRES 5/15	MARIO NAJI	763-862-4241
ANOKA COUNTY REPRESENTATIVE	U OF M SITE MANAGEMENT EXPIRES 5/15	BRUCE LUIKART	763-862-4242
EROSION CONTROL SUPERVISOR (CONTRACTOR)			

SEDIMENT CONTROL PRACTICES

TEMPORARY STOCKPILED TOPSOIL BERMS MUST INCLUDE PERIMETER BMPS AS PROVIDED IN THE PLAN AT LOCATIONS WHERE CONSTRUCTION STORM WATER DRAINS FROM THE PROJECT.

IN ORDER TO MAINTAIN SHEET FLOW AND MINIMIZE RILLS AND/OR GULLIES, THERE SHALL BE NO UNBROKEN SLOPE LENGTH OF GREATER THAT 75 FEET FOR SLOPES WITH A GRADE OF 1:3 OR STEEPER.

ALL STORM DRAIN INLETS MUST BE PROTECTED BY APPROPRIATE BMPS DURING CONSTRUCTION UNTIL ALL SOURCES WITH POTENTIAL DISCHARGE TO THE INLET HAVE BEEN STABILIZED.

VEHICLE TRACKING OF SEDIMENT FROM THE CONSTRUCTION SITE MUST BE MINIMIZED. STREET SWEEPING MUST BE USED IF SEDIMENT IS BEING TRACKED OFF THE CONSTRUCTION SITE.

LOCATION OF SWPPP REQUIREMENTS

REQUIREMENT	PLAN		MNDOT SPECIFICATION	SPECIAL PROVISION
	TITLE	LOCATION		
NPDES PERMIT COMPLIANCE			1701, 1702, & 1717	1717 (AIR, LAND & WATER) 1717 (NATIONAL POLLUTANT DISCHARGE ELIMINATION SYSTEM (NPDES) PERMIT)
CERTIFIED PERSONNEL IN EROSION AND SEDIMENT CONTROL SITE MANAGEMENT			1506, 1717, & 2573	1717 (AIR, LAND & WATER) 1717 (NATIONAL POLLUTANT DISCHARGE ELIMINATION SYSTEM (NPDES) PERMIT)
CHAIN OF RESPONSIBILITY			1506, 1717, & 2573	
PROJECT SCHEDULE / WEEKLY EROSION & SEDIMENT CONTROL SCHEDULE / COMPLETING INSPECTION / MAINTENANCE LOG	STORM WATER POLLUTION PREVENTION PLAN	SHEETS 61 - 62	1717 & 2573	1717 (AIR, LAND & WATER) 1717 (NATIONAL POLLUTANT DISCHARGE ELIMINATION SYSTEM (NPDES) PERMIT)
SWPPP PREPARATION				
SITE MAP / RECEIVING WATERS / DIRECTION OF FLOW	EROSION CONTROL PLAN	SHEETS 63 - 69	1717	
PROJECT SPECIFIC CONSTRUCTION STAGING	CONSTRUCTION STAGING & TRAFFIC CONTROL	SHEETS 26 - 31	1717	1717 (AIR, LAND & WATER) 1717 (NATIONAL POLLUTANT DISCHARGE ELIMINATION SYSTEM (NPDES) PERMIT) 1806 (DETERMINATION AND EXTENSION OF CONTRACT TIME)
TEMPORARY EROSION AND SEDIMENT CONTROL BMP LOCATIONS, INSTALLATION, TIMING OF INSTALLATION AND TYPE OF BMP	EROSION CONTROL PLAN, TABULATION CHARTS	SHEETS 11, 63 - 69	2573 & 2525	2575 (RAPID STABILIZATION SPECIFICATION)
ADDITIONAL TEMPORARY AND OR PERMANENT EROSION AND SEQIMENT CONTROL BMP'S NOT PROVIDED OR SHOWN IN THE PLAN	STORM WATER POLLUTION PREVENTION PLAN	SHEETS 61 - 62	1717, 2573, & 2575	1717 (AIR, LAND & WATER) 1717 (NATIONAL POLLUTANT DISCHARGE ELIMINATION SYSTEM (NPDES) PERMIT) 2575 (RAPID STABILIZATION SPECIFICATION)
MAINTENANCE OF EROSION AND SEDIMENT CONTROL DEVICES, REMOVAL OF TRACKED SEDIMENT, REMOVAL OF DEVICES			1717 & 2573	1514 (MAINTENANCE DURING CONSTRUCTION) 1717 (LAND AIR & WATER) 1717 (NATIONAL POLLUTANT DISCHARGE ELIMINATION SYSTEM (NPDES) PERMIT)
DEWATERING			2105.3B, & 2451.3C	DEWATERING MAY ALSO REQUIRE DNR PERMIT. NO DEWATERING IS ANTICIPATED FOR THIS PROJECT
FINAL STABILIZATION	TURF ESTABLISHMENT PLAN, TABULATION CHARTS	SHEETS 11, 63 - 69	1717, 2573, & 2575	1717 (AIR, LAND & WATER) 1717 (NATIONAL POLLUTANT DISCHARGE ELIMINATION SYSTEM (NPDES) PERMIT)
TEMPORARY EROSION AND SEDIMENT CONTROL DETAILS	EROSION CONTROL STANDARD PLAN	SHEETS 66 - 69	2575	2575 (RAPID STABILIZATION SPECIFICATION)
PERMANENT EROSION CONTROL DETAILS			2575	2575 (CONTROLLING EROSION AND ESTABLISHING VEGETATION)

1	04/09/2009	EM	JO	CK	ADDED HAZARDOUS MATERIAL CONTAINMENT NOTE PER MNDOT REVIEW COMMENTS.
NO	DATE	BY	CKD	APPR	REVISION
NAME: P:\02-621-10\Plan\20_SWPPP.dgn					

I HEREBY CERTIFY THAT THIS PLAN WAS PREPARED BY ME OR UNDER MY DIRECT SUPERVISION AND THAT I AM A DULY LICENSED PROFESSIONAL ENGINEER UNDER THE LAWS OF THE STATE OF MINNESOTA.
 PRINT NAME: CURT A. KOBILARCSIK
 SIGNATURE: *[Signature]*
 DATE: 7-14-14 LICENSE NO. 24756

DRAWN BY: ZB DATE: 07-07-14
 DESIGN BY: MN DATE: 07-07-14
 CHECKED BY: CAK DATE: 07-11-14

ANOKA COUNTY
HIGHWAY DEPT.

S.A.P. 002-621-010



STORM WATER POLLUTION PREVENTION PLAN
 Sheet 62 of 147 Sheets

STORM WATER POLLUTION PREVENTION PLAN (SWPPP)

AMENDING THE SWPPP

THE SWPPP MUST BE AMENDED TO RECORD CHANGES OR MODIFICATIONS TO PERMANENT BMPS OR OTHER STORM WATER TREATMENT SYSTEMS AND REMOVALS OF TEMPORARY BMPS. CHANGES TO TEMPORARY BMPS MAY BE RECORDED IN THIS SHEET. INCLUDE A BRIEF DESCRIPTION OF THE PROBLEM, LOCATION, NATURE OF ALTERATION AND COMMENTS. THIS RECORD IS TO BE RETAINED FOR THREE YEARS AFTER PROJECT COMPLETION.

Date Reported	Staff	Plan Location (sheet)	Project Location (station)	Problem, solution, and notes

NO	DATE	BY	CKD	APPR	REVISION	<small>I HEREBY CERTIFY THAT THIS PLAN WAS PREPARED BY ME OR UNDER MY DIRECT SUPERVISION AND THAT I AM A DULY LICENSED PROFESSIONAL ENGINEER UNDER THE LAWS OF THE STATE OF MINNESOTA.</small> PRINT NAME: CURT A. KOBILARCSIK SIGNATURE:  DATE: <u>7-14-14</u> LICENSE NO. 24756			DRAWN BY <u>ZR</u> DATE <u>07-07-14</u> DESIGN BY <u>MN</u> DATE <u>07-07-14</u> CHECKED BY <u>CAK</u> DATE <u>07-11-14</u>			 ANOKA COUNTY HIGHWAY DEPT.		S.A.P. 002-621-010	STORM WATER POLLUTION PREVENTION PLAN
NAME: P:\02-621-10\Plan\20_SWPPP.dgn 07/11/2014 2:13:32 PM										Sheet <u>63</u> of <u>147</u> Sheets					

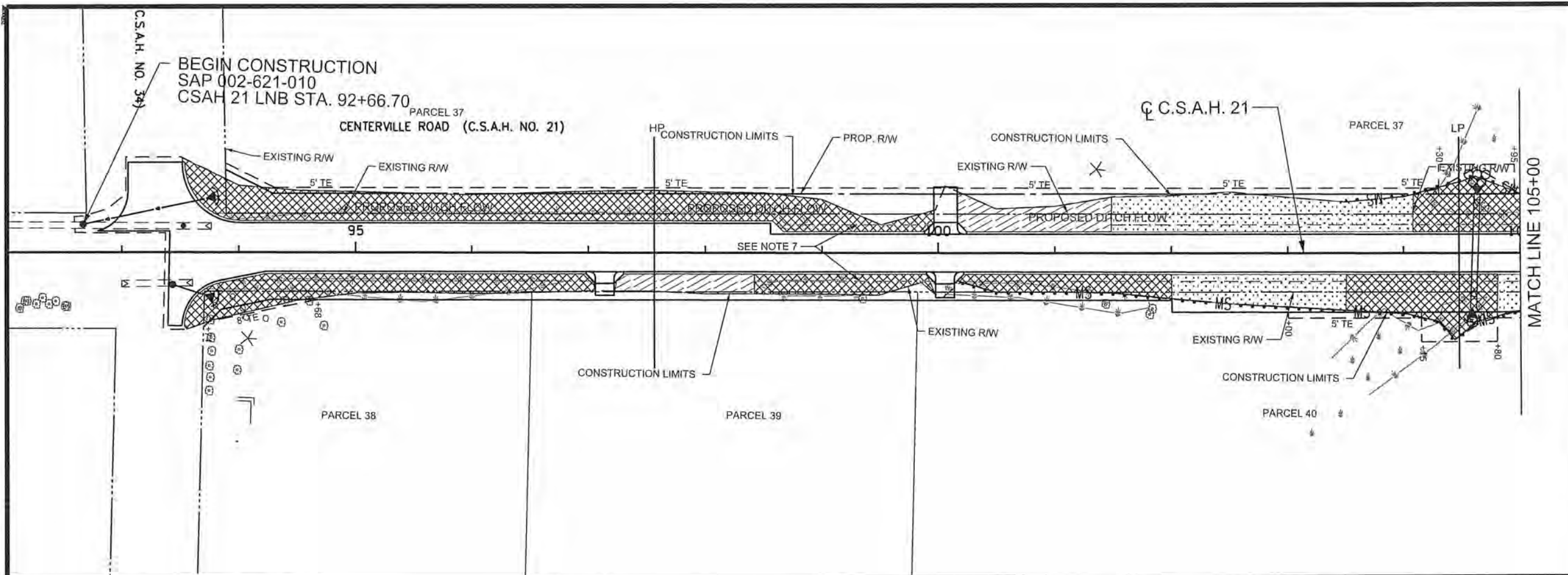

LEGEND

- PROPOSED APRON
- INPLACE APRON
- PROPOSED STORM SEWER
- INPLACE CULVERT
- PROPOSED CULVERT
- SILT FENCE TYPE MACHINE SLICED
- RIPRAP (CLASS II UNLESS OTHERWISE NOTED)
- SOD APRON INLET OR OUTLET
- INLET PROTECTION
- WETLAND BOUNDARIES
- EXISTING WETLAND
- SODDING TYPE SALT RESISTANT
- SEEDING MIX 250 FERTILIZER TYPE 3 EROSION CONTROL BLANKET CATEGORY 00
- SEEDING MIX 310 FERTILIZER TYPE 4 EROSION CONTROL BLANKET CATEGORY 00
- EDGE OF EROSION CONTROL BLANKET CATEGORY 00

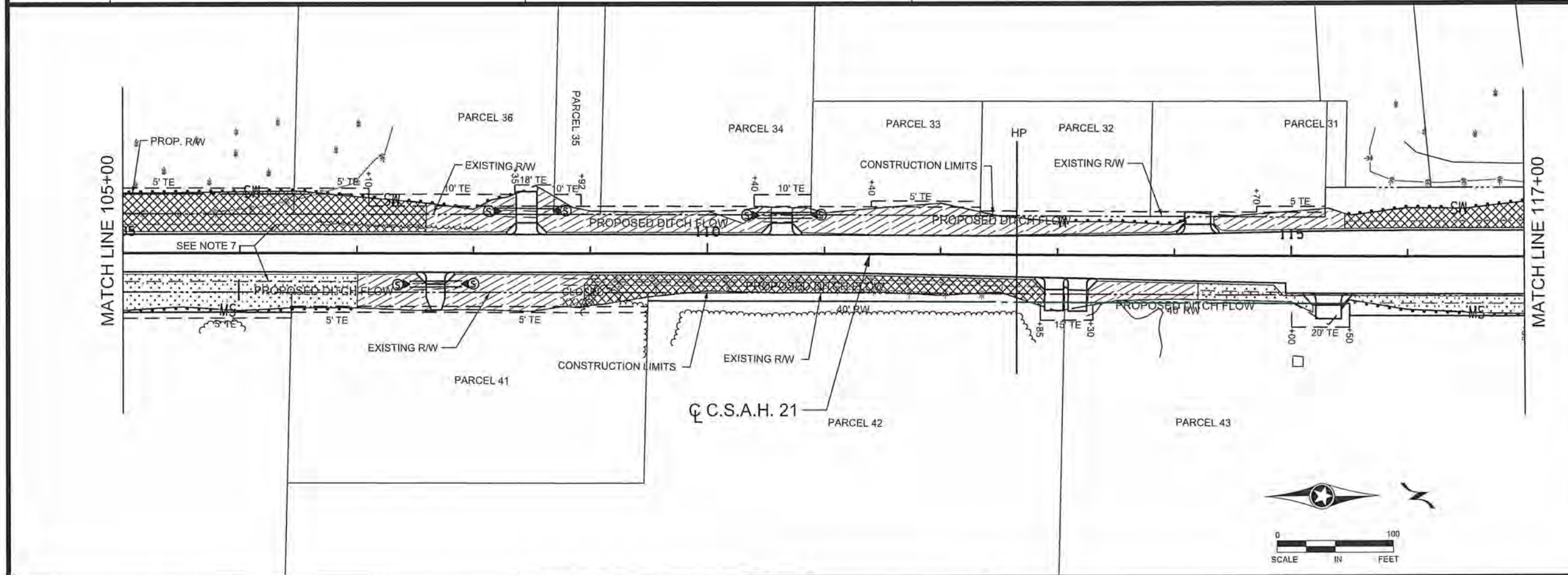

- NOTES**
- 1.) THE CONTRACTOR SHALL CONSTRUCT WASHED GRAVEL ENTRANCES AT POINTS OF EXIT FROM THE WORK AREA ONTO EXISTING BITUMINOUS PAVEMENT AS DIRECTED BY THE ENGINEER. SHALL BE CONSIDERED INCIDENTAL TO THE PROJECT.
 - 2.) SILT FENCE SHALL FOLLOW AS CLOSE AS POSSIBLE A SINGLE CONTOUR.
 - 3.) SILT FENCE SHALL BE CLEANED OUT OR REPLACED WHEN SEDIMENT REACHES 8" OR $\frac{1}{3}$ OF SILT FENCE HEIGHT.
 - 4.) WHEN SEDIMENT DEPOSITS IN A WATER OF THE STATE, THE MATERIAL MUST BE REMOVED WITHIN 7 DAYS.
 - 5.) IF SILT DEPOSITS IN THE ANOKA COUNTY RIGHT-OF-WAY, THE CONTRACTOR IS RESPONSIBLE FOR ITS REMOVAL.
 - 6.) ALL GRADED AREAS ARE TO BE REVEGETATED WITHIN 14 DAYS OF THE COMPLETION OF GRADING.
 - 7.) FOR RURAL SECTION: PLACE 8' WIDTH OF EROSION CONTROL BLANKET CATEGORY 00 ALONG EDGE OF PAVEMENT IN SEEDED AREAS. MULCH THE REMAINING AREA WITHIN CONSTRUCTION LIMITS.

01	7-21-14	ZB	MN	MNDOT COMMENTS
NO	DATE	BY	CKD	APPR
NAME: P:\02-621-10\Plan\0262110_EC_1.dgn 07/21/2014 10:58:06 AM				

I HEREBY CERTIFY THAT THIS PLAN WAS PREPARED BY ME OR UNDER MY DIRECT SUPERVISION AND THAT I AM A DULY LICENSED PROFESSIONAL ENGINEER UNDER THE LAWS OF THE STATE OF MINNESOTA.

PRINT NAME: CURT A. KOBIARCSIK
 SIGNATURE: *Curt A. Kobiarcsik*
 DATE: 7-22-14 LICENSE NO. 24756

DRAWN BY: ZB DATE: 07-07-14
 DESIGN BY: MN DATE: 07-07-14
 CHECKED BY: CAK DATE: 07-11-14

ANOKA COUNTY
HIGHWAY DEPT.

S.A.P. 002-621-010

EROSION CONTROL AND TURF ESTABLISHMENT PLAN
 STA 92+66.70 TO 117+00.00
 Sheet 64 of 147 Sheets

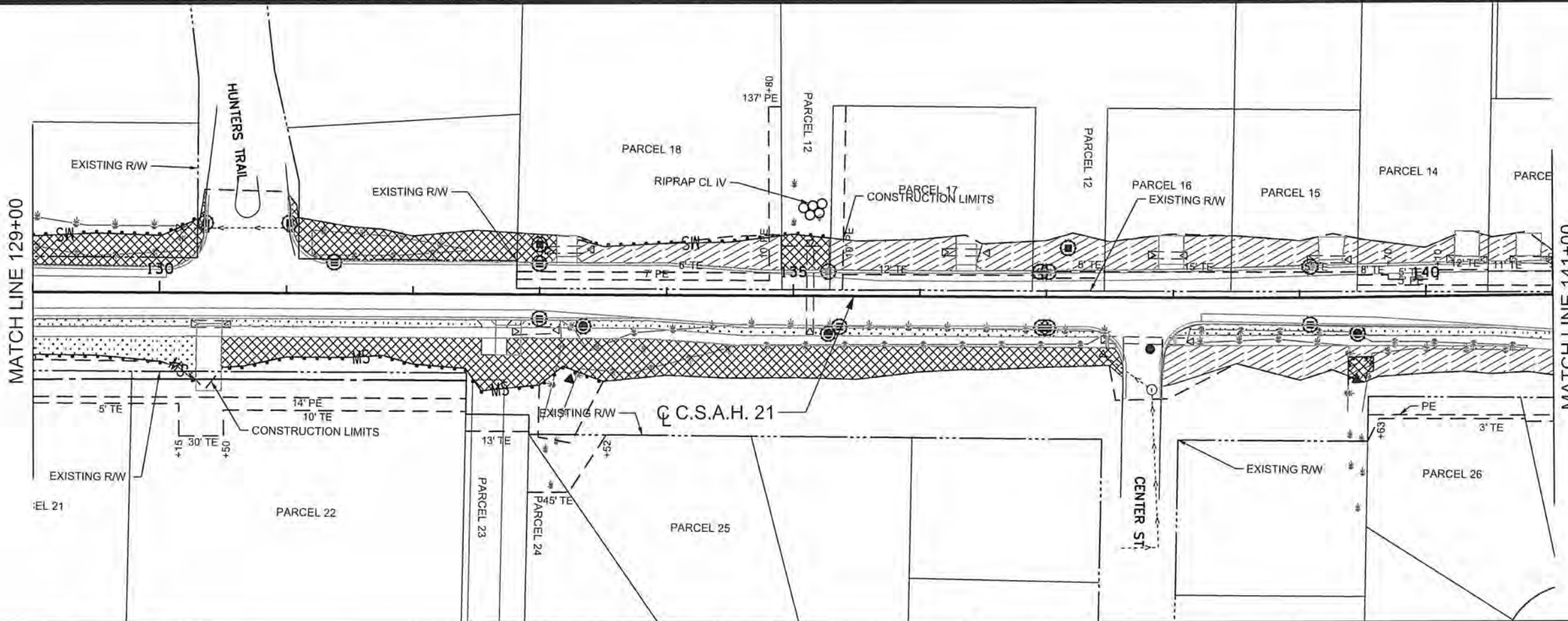
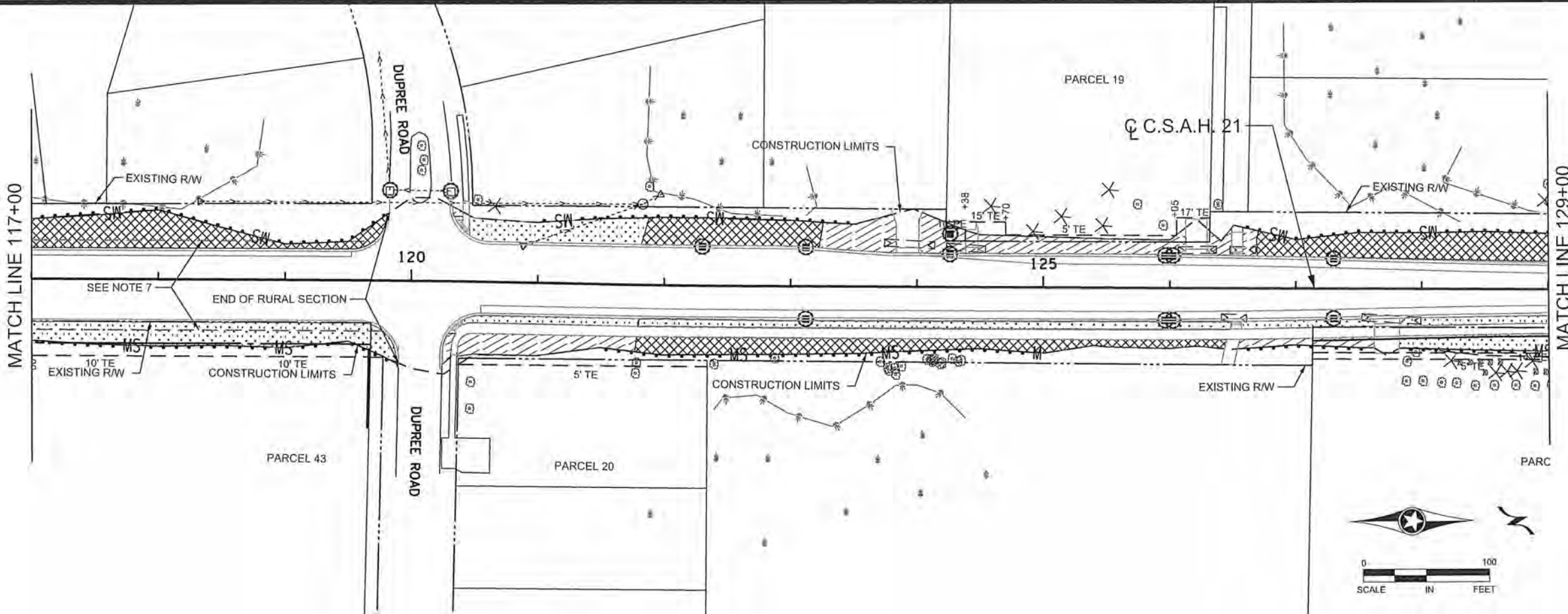

LEGEND

- PROPOSED CATCH BASIN
- INPLACE CATCH BASIN
- ▲ PROPOSED APRON
- ▷ INPLACE APRON
- PROPOSED STORM SEWER
- - - INPLACE STORM SEWER
- - - INPLACE CULVERT
- MS— SILT FENCE TYPE MACHINE SLICED
- ⊗ RIPRAP (CLASS II UNLESS OTHERWISE NOTED)
- ⊙ SOD APRON INLET OR OUTLET
- INLET PROTECTION
- WETLAND BOUNDARIES
- ▨ EXISTING WETLAND
- ▨ SODDING TYPE SALT RESISTANT
- ▨ SEEDING MIX 250 FERTILIZER TYPE 3 EROSION CONTROL BLANKET CATEGORY 00
- ▨ SEEDING MIX 310 FERTILIZER TYPE 4 EROSION CONTROL BLANKET CATEGORY 00
- - - EDGE OF EROSION CONTROL BLANKET CATEGORY 00

- NOTES**
- 1.) THE CONTRACTOR SHALL CONSTRUCT WASHED GRAVEL ENTRANCES AT POINTS OF EXIT FROM THE WORK AREA ONTO EXISTING BITUMINOUS PAVEMENT AS DIRECTED BY THE ENGINEER. SHALL BE CONSIDERED INCIDENTAL TO THE PROJECT.
 - 2.) SILT FENCE SHALL FOLLOW AS CLOSE AS POSSIBLE A SINGLE CONTOUR.
 - 3.) SILT FENCE SHALL BE CLEANED OUT OR REPLACED WHEN SEDIMENT REACHES 8" OR $\frac{1}{3}$ OF SILT FENCE HEIGHT.
 - 4.) WHEN SEDIMENT DEPOSITS IN A WATER OF THE STATE, THE MATERIAL MUST BE REMOVED WITHIN 7 DAYS.
 - 5.) IF SILT DEPOSITS IN THE ANOKA COUNTY RIGHT-OF-WAY, THE CONTRACTOR IS RESPONSIBLE FOR ITS REMOVAL.
 - 6.) ALL GRADED AREAS ARE TO BE REVEGETATED WITHIN 14 DAYS OF THE COMPLETION OF GRADING.
 - 7.) FOR RURAL SECTION: PLACE 8' WIDTH OF EROSION CONTROL BLANKET CATEGORY 00 ALONG EDGE OF PAVEMENT IN SEEDED AREAS. MULCH THE REMAINING AREA WITHIN CONSTRUCTION LIMITS URBAN SECTION: PLACE EROSION CONTROL BLANKET CATEGORY 00 OVER ENTIRE SEEDED AREA.

01	7-21-14	ZB	MN	MNDOT COMMENTS
NO	DATE	BY	CKD	APPR
NAME: P:\02-621-10\Plan\0262110_EC_2.dgn				

I HEREBY CERTIFY THAT THIS PLAN WAS PREPARED BY ME OR UNDER MY DIRECT SUPERVISION AND THAT I AM A DULY LICENSED PROFESSIONAL ENGINEER UNDER THE LAWS OF THE STATE OF MINNESOTA.

PRINT NAME: CURT A. KOBIARCSIK

SIGNATURE: *Curt A. Kobilarcsik*

DATE: 7-22-14 LICENSE NO. 24756

DRAWN BY: ZB DATE: 07-07-14

DESIGN BY: MN DATE: 07-07-14

CHECKED BY: CAK DATE: 07-11-14

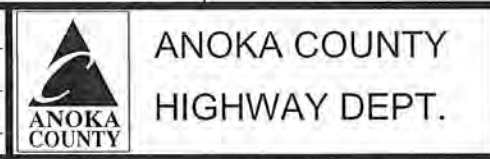

S.A.P. 002-621-010

EROSION CONTROL AND TURF ESTABLISHMENT PLAN

STA 117+00.00 TO 141+00.00

Sheet 65 of 147 Sheets

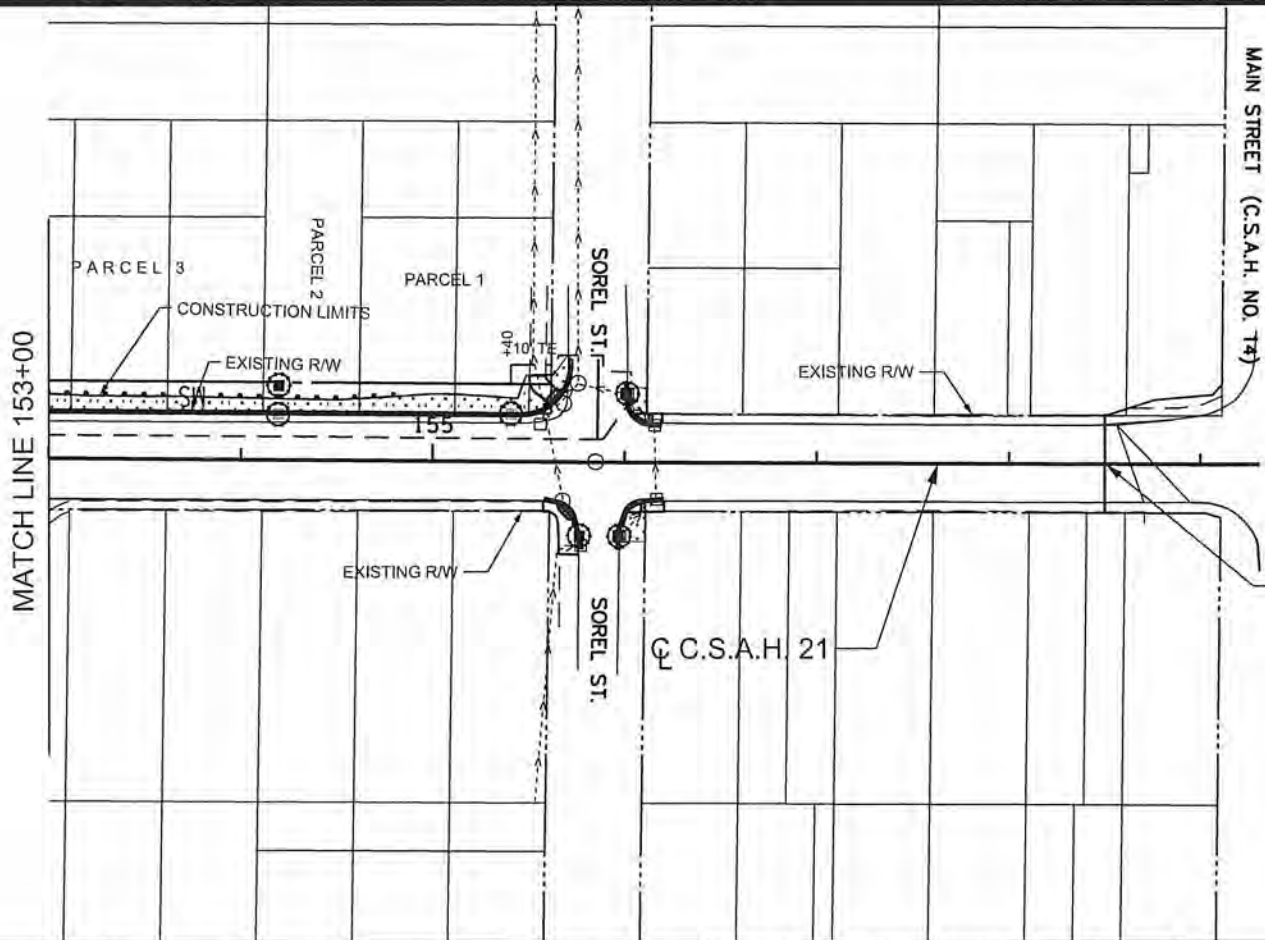
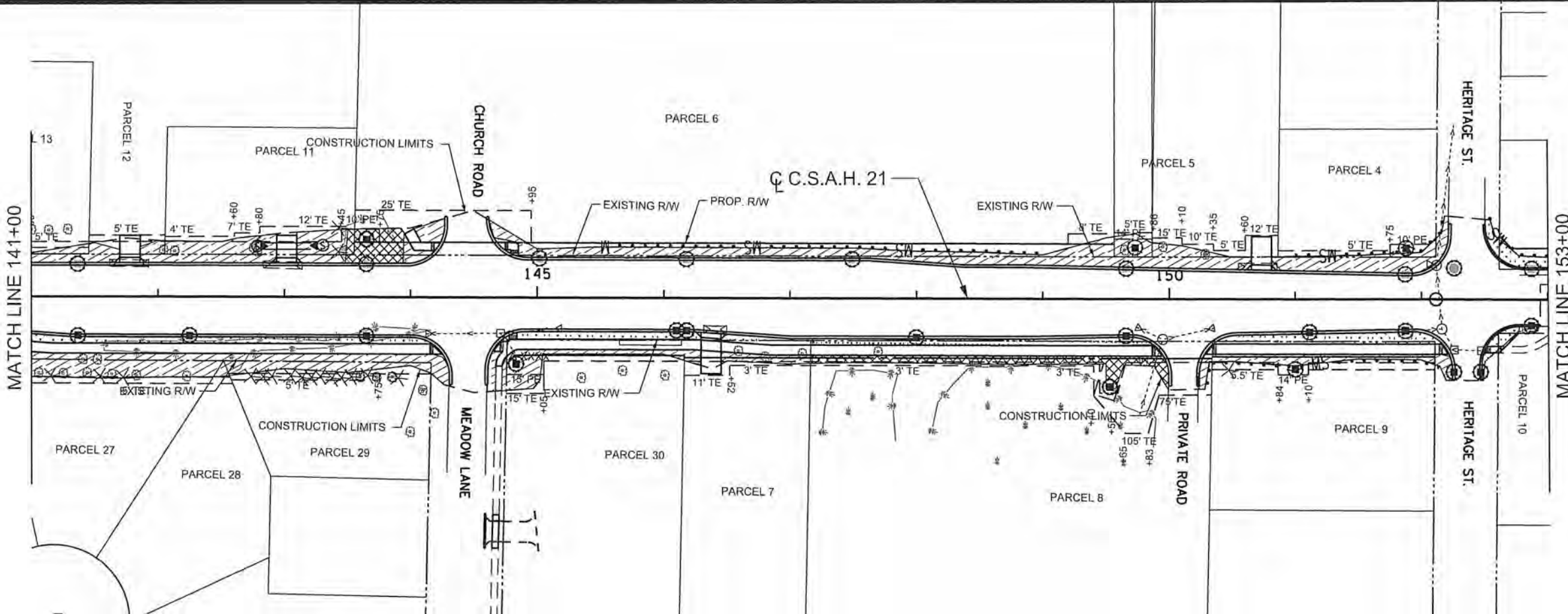

END CONSTRUCTION
 SAP 002-621-010
 CSAH 21 LNB STA. 158+50.00

LEGEND

- PROPOSED CATCH BASIN
- INPLACE CATCH BASIN
- PROPOSED MANHOLE
- INPLACE MANHOLE
- ▲ PROPOSED APRON
- ▽ INPLACE APRON
- PROPOSED STORM SEWER
- INPLACE STORM SEWER
- MS SILT FENCE TYPE MACHINE SLICED
- INLET PROTECTION
- WETLAND BOUNDARIES
- EXISTING WETLAND
- SODDING TYPE SALT RESISTANT
- SEEDING MIX 250 FERTILIZER TYPE 3 EROSION CONTROL BLANKET CATEGORY 00
- SEEDING MIX 310 FERTILIZER TYPE 4 EROSION CONTROL BLANKET CATEGORY 00

- ### NOTES
- 1.) THE CONTRACTOR SHALL CONSTRUCT WASHED GRAVEL ENTRANCES AT POINTS OF EXIT FROM THE WORK AREA ONTO EXISTING BITUMINOUS PAVEMENT AS DIRECTED BY THE ENGINEER. SHALL BE CONSIDERED INCIDENTAL TO THE PROJECT.
 - 2.) SILT FENCE SHALL FOLLOW AS CLOSE AS POSSIBLE A SINGLE CONTOUR.
 - 3.) SILT FENCE SHALL BE CLEANED OUT OR REPLACED WHEN SEDIMENT REACHES 8" OR $\frac{1}{3}$ OF SILT FENCE HEIGHT.
 - 4.) WHEN SEDIMENT DEPOSITS IN A WATER OF THE STATE, THE MATERIAL MUST BE REMOVED WITHIN 7 DAYS.
 - 5.) IF SILT DEPOSITS IN THE ANOKA COUNTY RIGHT-OF-WAY, THE CONTRACTOR IS RESPONSIBLE FOR ITS REMOVAL.
 - 6.) ALL GRADED AREAS ARE TO BE REVEGETATED WITHIN 14 DAYS OF THE COMPLETION OF GRADING.
 - 7.) FOR RURAL SECTION: PLACE 8' WIDTH OF EROSION CONTROL BLANKET CATEGORY 00 ALONG EDGE OF PAVEMENT IN SEEDED AREAS. MULCH THE REMAINING AREA WITHIN CONSTRUCTION LIMITS URBAN SECTION: PLACE EROSION CONTROL BLANKET CATEGORY 00 OVER ENTIRE SEEDED AREA.

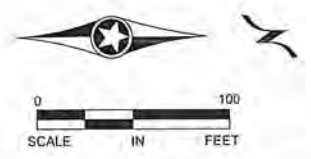

01	7-21-14	ZB	MN	MNDOT COMMENTS
NO	DATE	BY	CKD	APPR
NAME: P:\02-621-10\Plan\0262110_EC_3.dgn 07/21/2014 10:58:10 AM				

I HEREBY CERTIFY THAT THIS PLAN WAS PREPARED BY ME OR UNDER MY DIRECT SUPERVISION AND THAT I AM A DULY LICENSED PROFESSIONAL ENGINEER UNDER THE LAWS OF THE STATE OF MINNESOTA.

PRINT NAME: CURT A. KOBILARCSIK
 SIGNATURE: *Curt Kobilarcsik*
 DATE: 7-22-14 LICENSE NO. 24756

DRAWN BY: ZB DATE: 07-07-14
 DESIGN BY: MN DATE: 07-07-14
 CHECKED BY: CAK DATE: 07-11-14

ANOKA COUNTY
HIGHWAY DEPT.

S.A.P. 002-621-010

EROSION CONTROL AND TURF ESTABLISHMENT PLAN
 STA 141+00.00 TO 158+50.00
 Sheet 66 of 147 Sheets

PLOTTED/REVISED:
 \$\$\$@DATE@\$\$\$

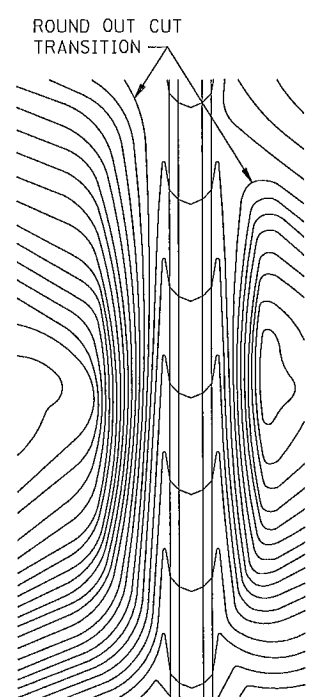

CONTOURING ROAD CUTS

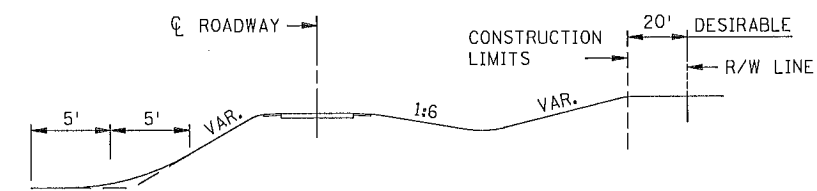

ROUNDING SHOULDERS AND BACKSLOPES

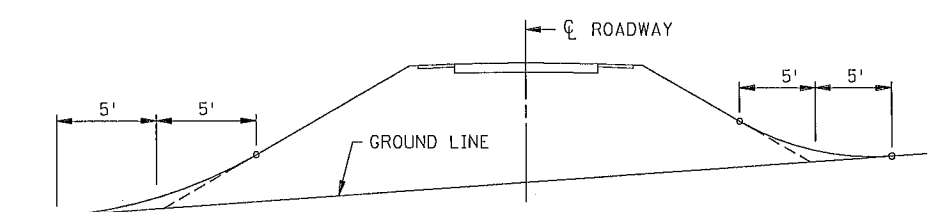

SHAPING FOR DRAINAGE ALONG THE TOE OF FILL SLOPES

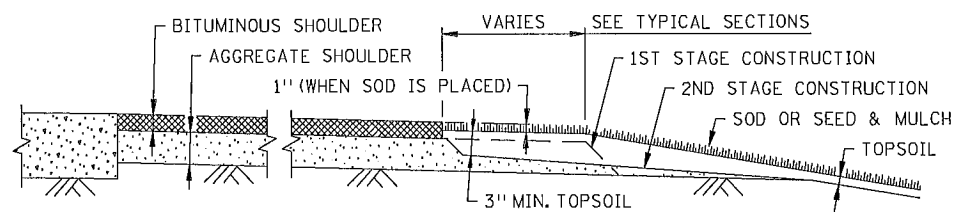

SHAPING AND TOPSOILING INSLOPES

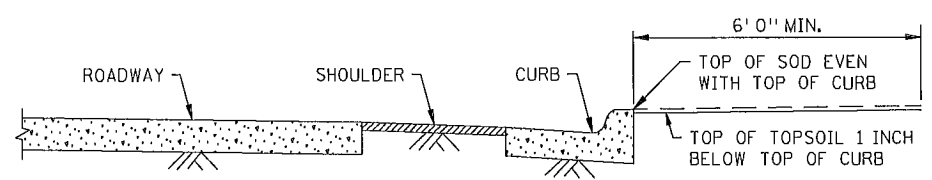

SHAPING ADJACENT TO CURBS WHEN SOD IS PLACED

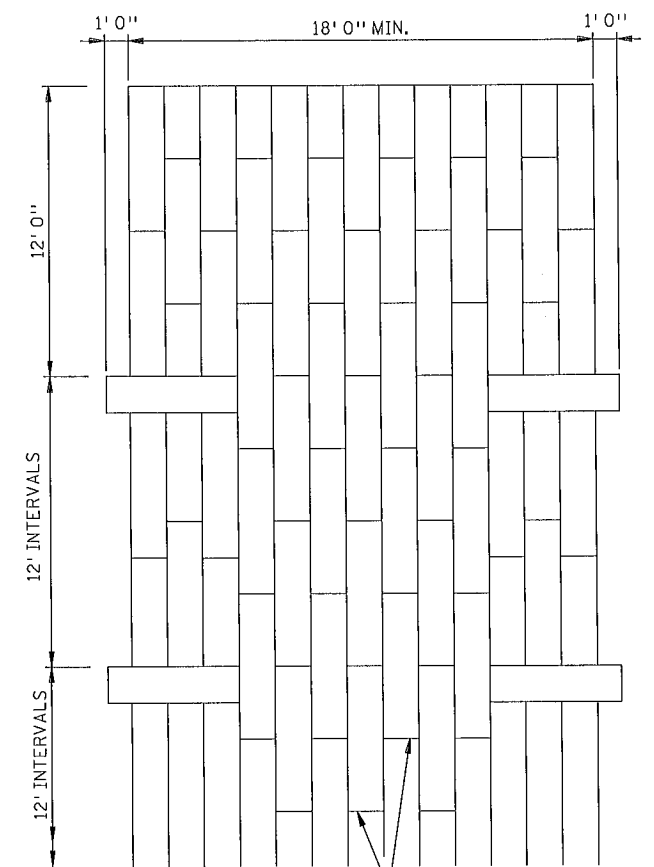

PLAN VIEW

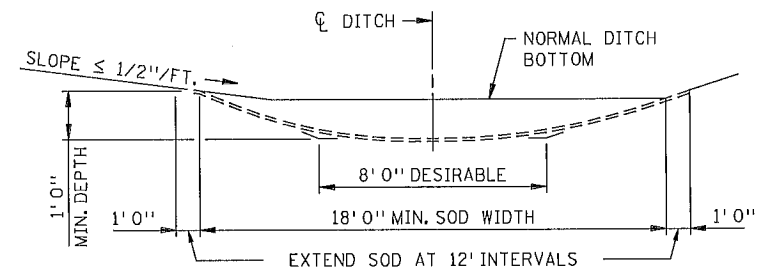

SODDED DITCH CROSS SECTION
 WHERE FRONT OR BACK SLOPE IS FLAT (LESS THAN 1/2"/FT.),
 FIRST NOTCH DITCH AND THEN PROVIDE ROUNDING.

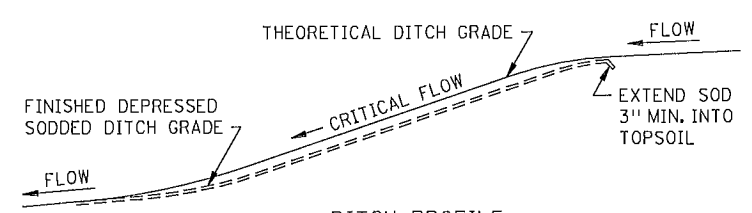

DITCH PROFILE
 SODDED DITCH DETAILS

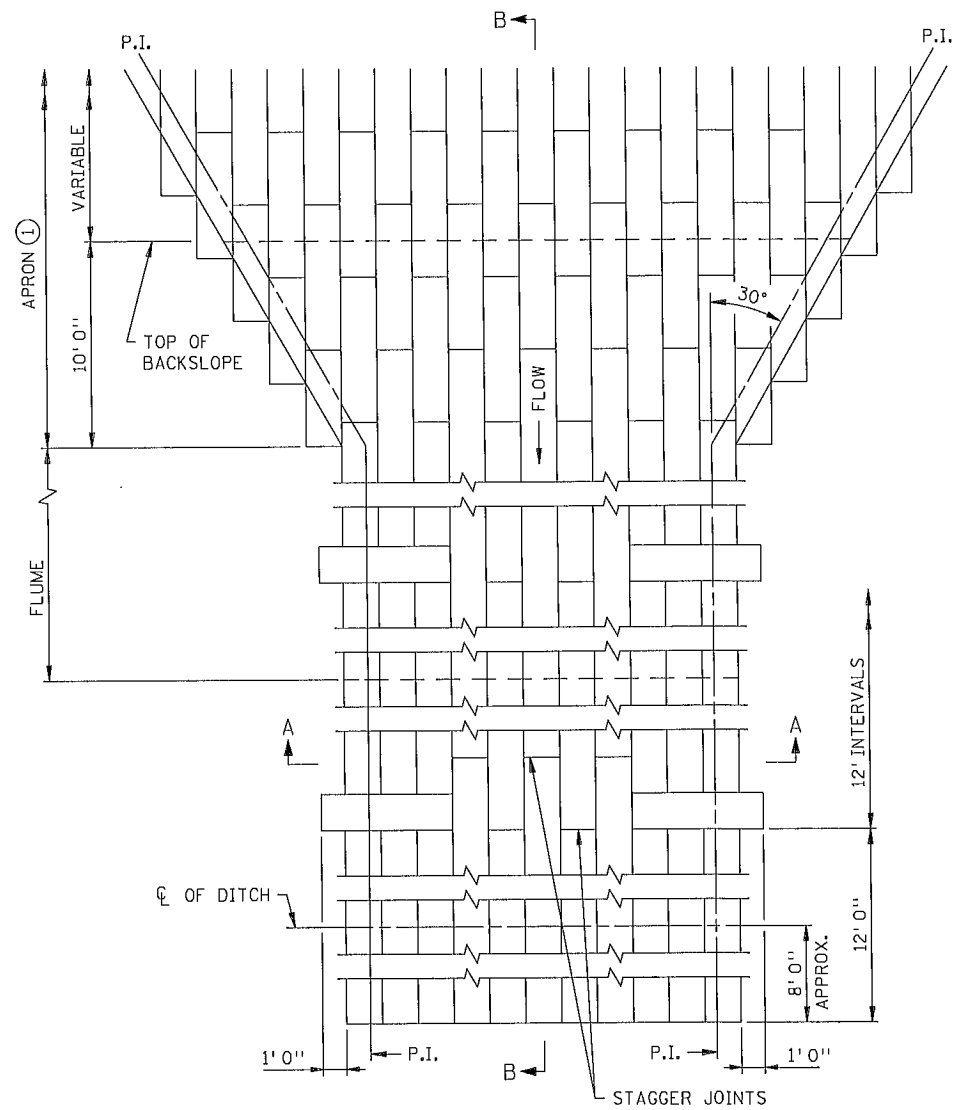

PLAN VIEW

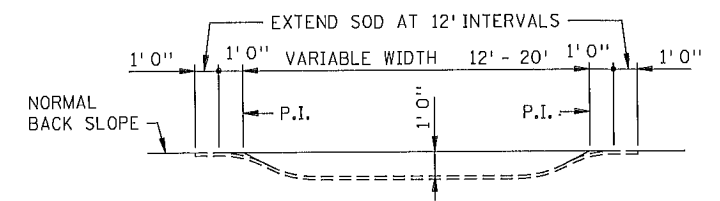

SECTION A-A

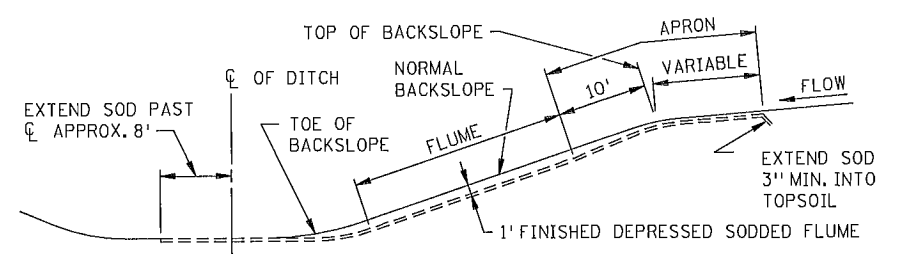

SECTION B-B
 SODDED FLUME DETAILS

NOTES:
 SEE SPEC. 2575.3 FOR ADDITIONAL INFORMATION.
 (1) CONSTRUCT TAPER AS DIRECTED BY THE ENGINEER.

STANDARD SHEET NO. 5-297.404	TITLE: PERMANENT EROSION CONTROL ALONG ROADWAYS, DITCHES AND FLUMES
STANDARD APPROVED: NOVEMBER 20, 2002	
S.P. 002-621-010	SHEET NO. 67 OF 147 SHEETS

DISTRICT #: \$@DISTRICT@
 USER NAME: \$\$\$@USER@NAME@
 PATH & FILENAME: \$\$\$@PATH@FILENAME@\$\$\$
 FILE NAME: @FILENAME@

PLOTTED/REVISED:
 \$\$\$@DATE\$\$\$\$

DISTRICT #: \$\$\$@DISTRICT@
 USER NAME: \$\$\$@USER@NAME@
 PATH & FILENAME: \$\$\$@PATH@FILENAME@

FILE NAME:
 @FILENAME@

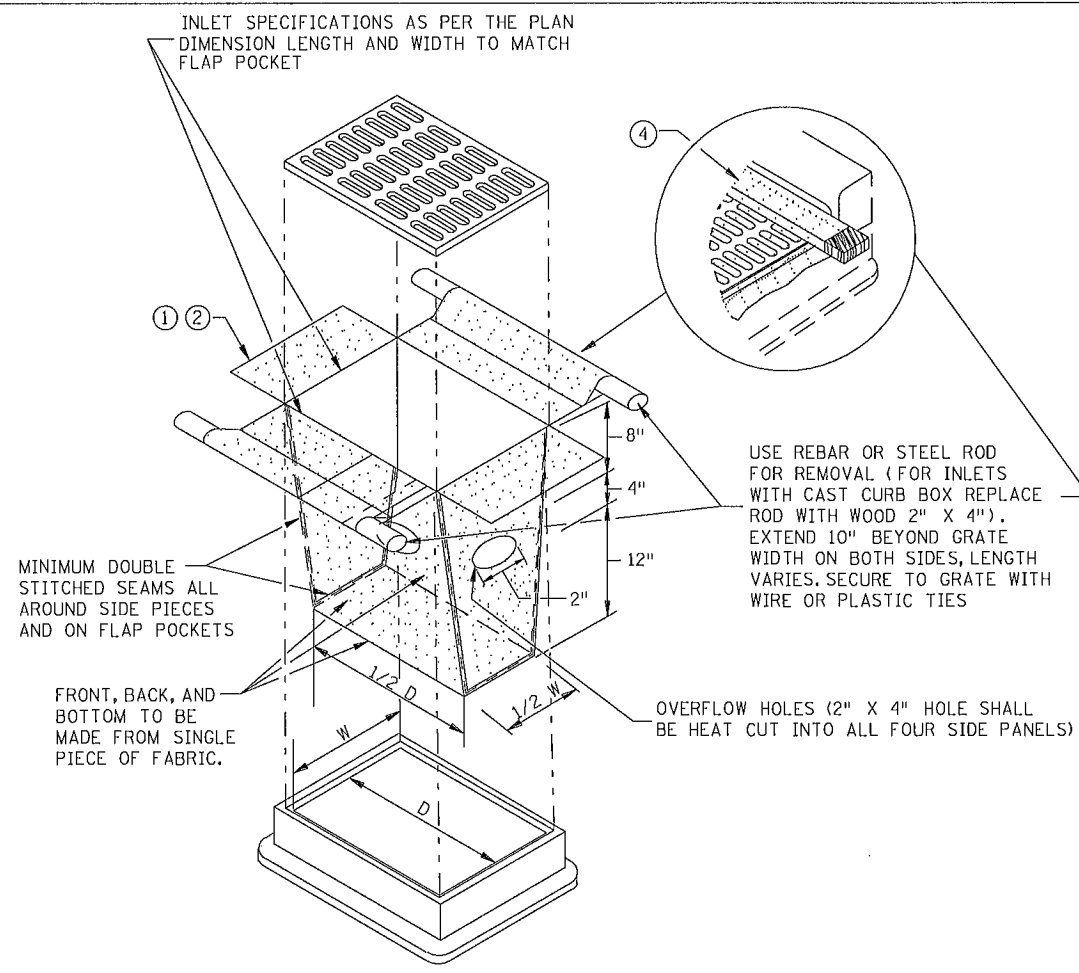

FILTER BAG INSERT ③

(CAN BE INSTALLED IN ANY INLET TYPE WITH OR WITHOUT A CURB BOX)

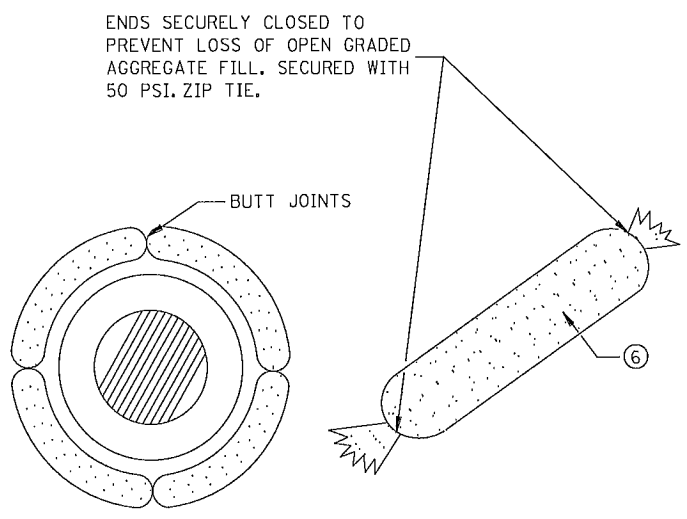

ROCK LOG/COMPOST LOG

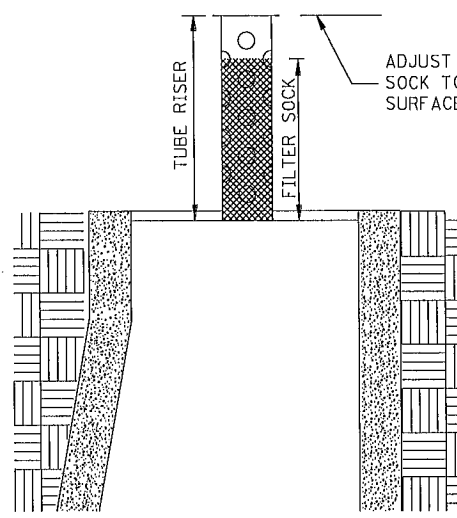
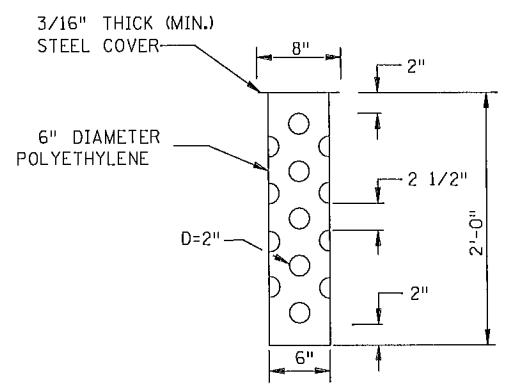

SECTION (UP POSITION)

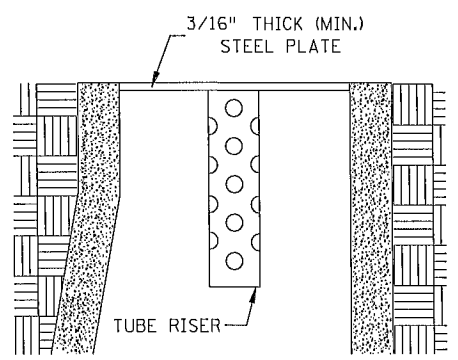
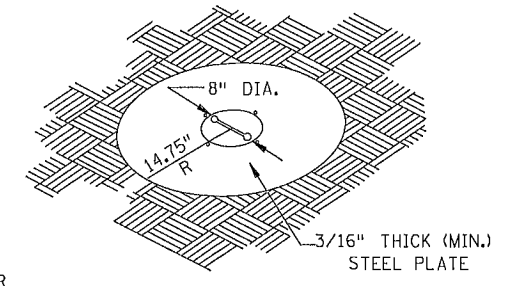

SECTION (DOWN POSITION)

POP-UP HEAD

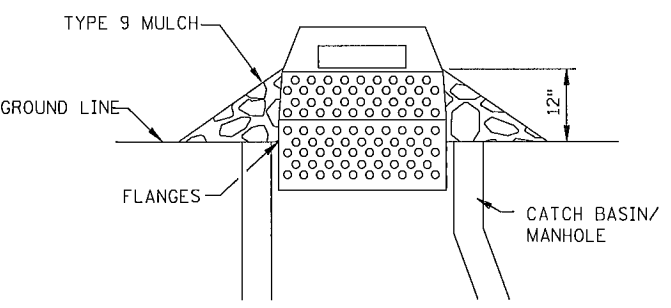

SEDIMENT CONTROL INLET HAT

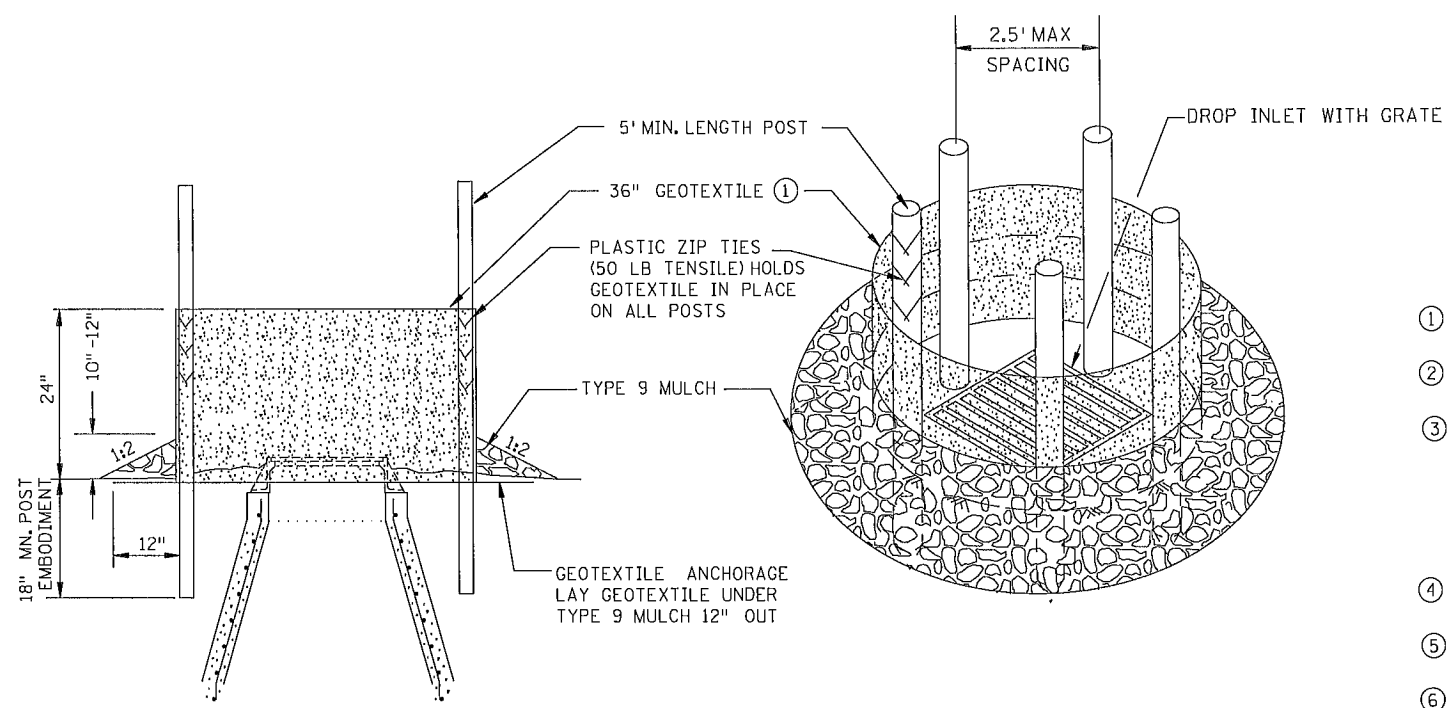

SILT FENCE RING AND ROCK FILTER BERM

USE WHERE INLET DRAINS IN AN AREA WITH SLOPES AT 1:3 OR LESS

NOTES:

SEE SPECS. 2573, 3137, 3886 & 3891.

MANUFACTURED ALTERNATIVES LISTED ON Mn/DOT'S APPROVED PRODUCTS LIST MAY BE SUBSTITUTED.

- ① ALL GEOTEXTILE USED FOR INLET PROTECTION SHALL BE MONOFILAMENT IN BOTH DIRECTIONS, MEETING SPEC. 3886.
- ② FINISHED SIZE, INCLUDING POCKETS WHERE REQUIRED SHALL EXTEND A MINIMUM OF 10 INCHES AROUND THE PERIMETER TO FACILITATE MAINTENANCE OR REMOVAL.
- ③ INSTALLATION NOTES:
DO NOT INSTALL FILTER BAG INSERT IN INLETS SHALLOWER THAN 30 INCHES, MEASURED FROM THE BOTTOM OF THE INLET TO THE TOP OF THE GRATE. THE INSTALLED BAG SHALL HAVE A MINIMUM SIDE CLEARANCE OF 3 INCHES BETWEEN THE INLET WALLS AND THE BAG, MEASURED AT THE BOTTOM OF THE OVERFLOW HOLES. WHERE NECESSARY THE CONTRACTOR SHALL CLINCH THE BAG, USING PLASTIC ZIP TIES, TO ACHIEVE THE 3 INCH CLEARANCE.
- ④ FLAP POCKETS SHALL BE LARGE ENOUGH TO ACCEPT WOOD 2 INCH X 4 INCH OR USE A ROCK SOCK OR SAND BAGS IN PLACE OF THE FLAP POCKETS.
- ⑤ SOCK HEIGHT MUST NOT BE SO HIGH AS TO SLOW DOWN WATER FILTRATION TO CAUSE FLOODING OF THE ROADWAY.
- ⑥ GEOTEXTILE SOCK BETWEEN 4-10 FEET LONG AND 4-6 INCH DIAMETER. SEAM TO BE JOINED BY TWO ROWS OF STITCHING WITH A PLASTIC MESH BACKING OR PROVIDE A HEAT BONDED SEAM (OR APPROVED EQUIVALENT). FILL ROCK LOG WITH OPEN GRADED AGGREGATE CONSISTING OF SOUND DURABLE PARTICLES OF COARSE AGGREGATE CONFORMING TO SPEC. 3137 TABLE 3137-1; CA-3 GRADATION.

NOTE:
 THE SEDIMENT CONTROL BARRIER SHALL BE A METAL OR PLASTIC/POLYETHYLENE RISER SIZED TO FIT INSIDE THE CATCH BASIN/MANHOLE; HAVE PERFORATIONS TO ALLOW FOR WATER INFILTRATION; HAVE AN OVERFLOW OPENING, FLANGES AND A LID/COVER.

STANDARD SHEET NO. 297.405 (4 OF 4)
STANDARD APPROVED: MARCH 29, 2012

TITLE: TEMPORARY SEDIMENT CONTROL STORM DRAIN INLET PROTECTION
--

PLOTTED/REVISED:
\$\$\$\$@DATE\$\$\$\$

DISTRICT #: \$@DISTRICT@
USER NAME: \$@USER\$NAME@
PATH & FILENAME: \$\$\$\$@PATHFILENAME\$\$\$\$

FILE NAME:
@FILENAME@

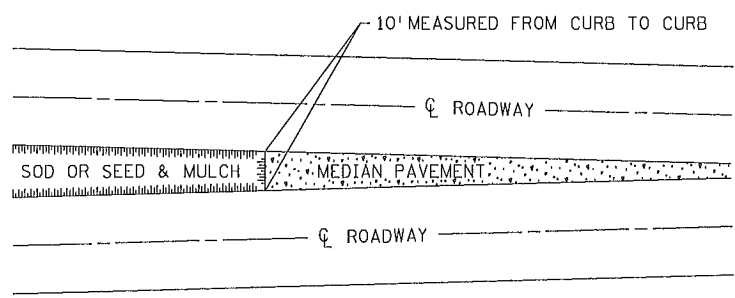

SODDING LIMITS AT GORE AREA

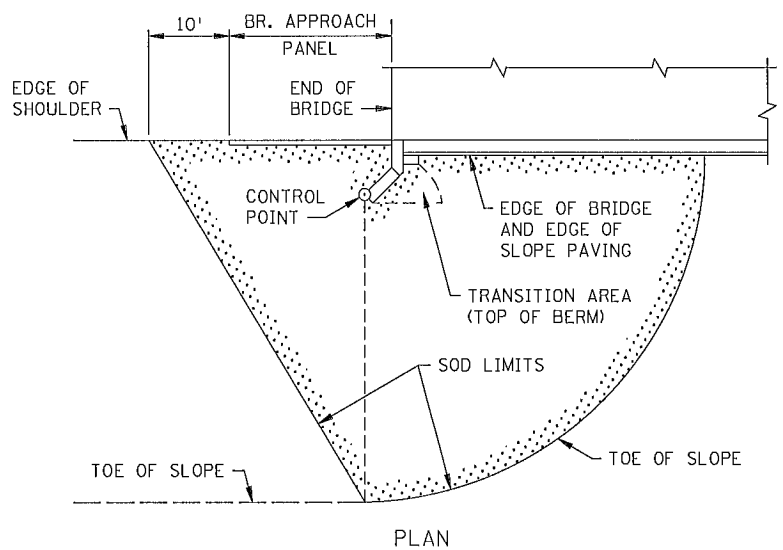

PLAN

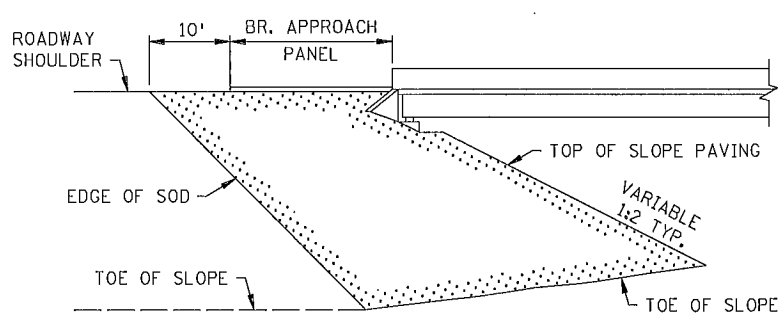

ELEVATION

SODDING LIMITS AT BRIDGE APPROACH FILLS

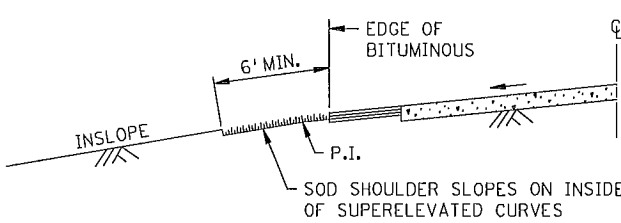

SODDING INSLOPES OF SUPERELEVATED CURVES

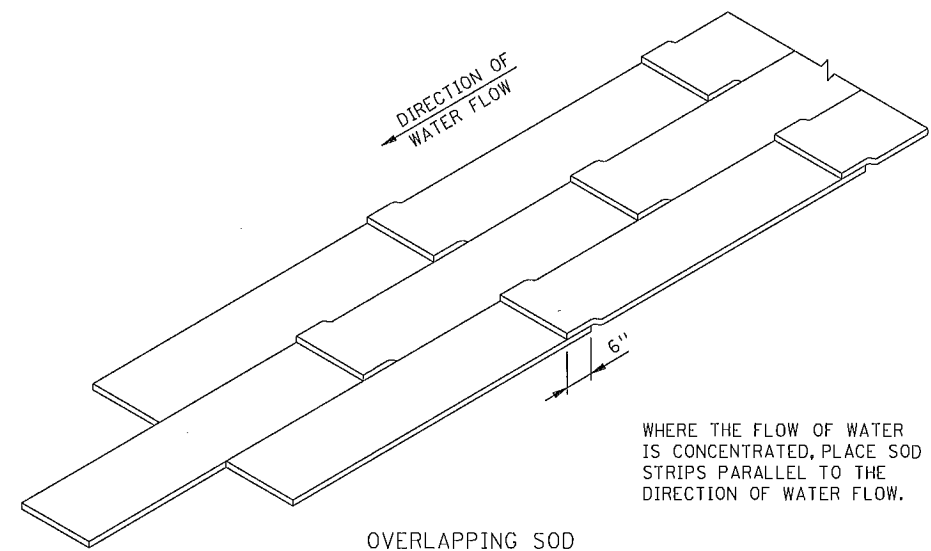

OVERLAPPING SOD

WHERE THE FLOW OF WATER IS CONCENTRATED, PLACE SOD STRIPS PARALLEL TO THE DIRECTION OF WATER FLOW.

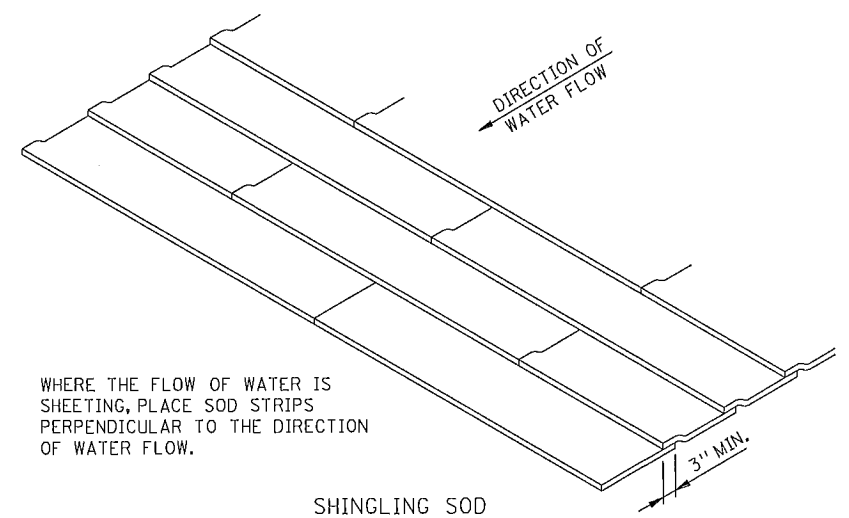

SHINGLING SOD

WHERE THE FLOW OF WATER IS SHEETING, PLACE SOD STRIPS PERPENDICULAR TO THE DIRECTION OF WATER FLOW.

SPECIAL SOD PLACEMENT TECHNIQUES

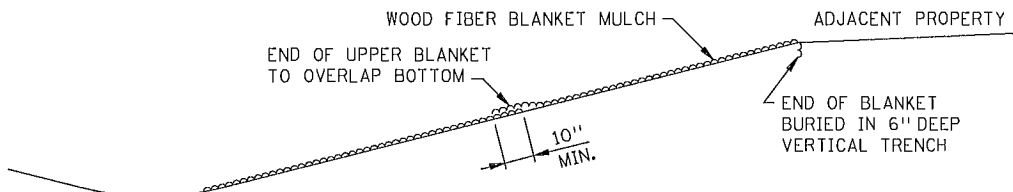

WOOD FIBER BLANKET INSTALLATION ON A CUT SLOPE

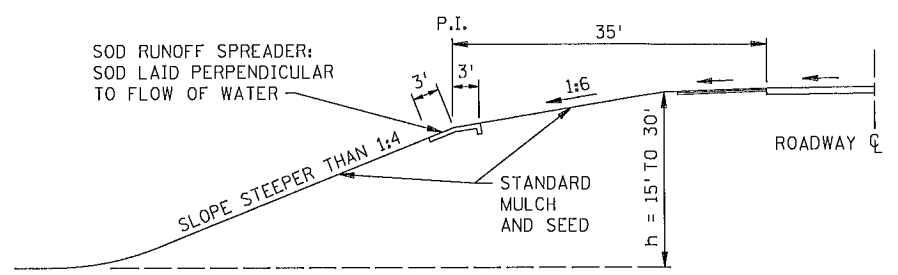

BROKEN-BACK SAFETY FILL SLOPE

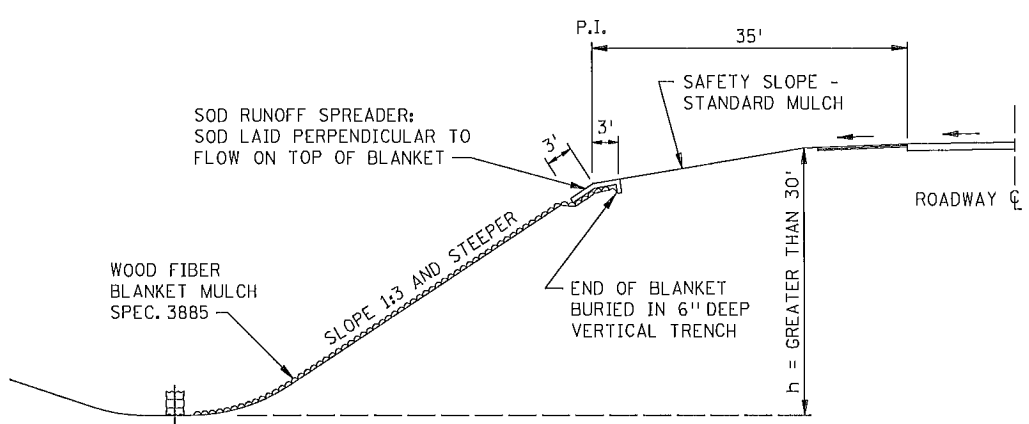

WOOD FIBER BLANKET INSTALLATION ON AN INSLOPE (WHEN REQUIRED)

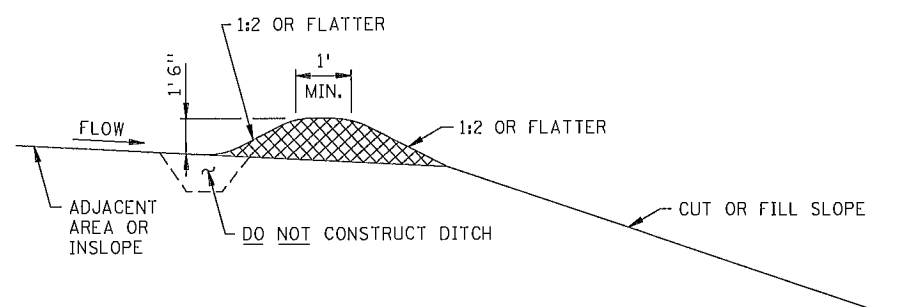

PERMANENT SLOPE PROTECTION DIKE

STANDARD SHEET NO. 5-297.406	TITLE:
STANDARD APPROVED: JANUARY 31, 1985	PERMANENT EROSION CONTROL ALONG ROADWAYS AND AT GORE AREAS & BRIDGE APPROACH FILLS
REVISION DATE 10-26-2000	S.P. 002-621-010

PLOTTED/REVISED:
\$\$\$\$DATE\$\$\$\$

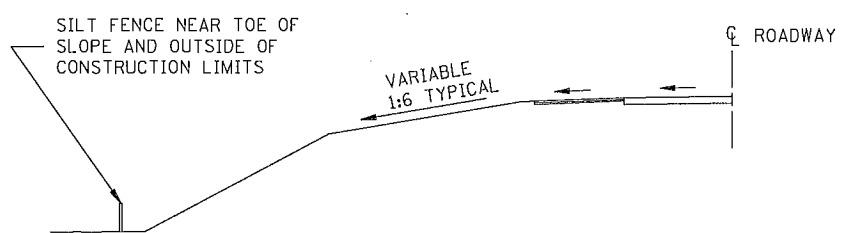

LOCATION OF SILT FENCE
AT TOE OF ROADWAY EMBANKMENT

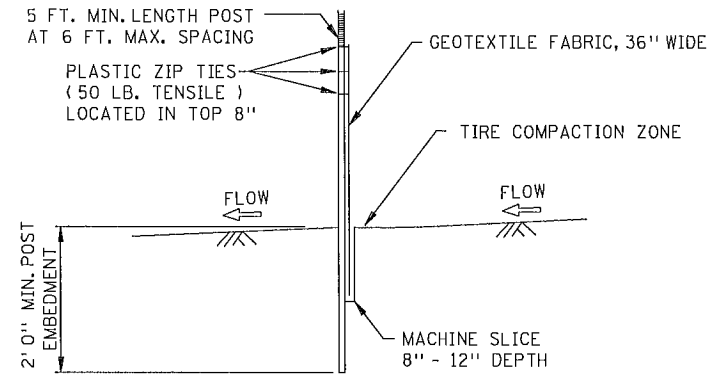

SILT FENCE, MACHINE SLICED
DESIGN GUIDELINES:
TO PROTECT AREAS FROM SHEET FLOW.
MAXIMUM CONTRIBUTING AREA: 1 ACRE.

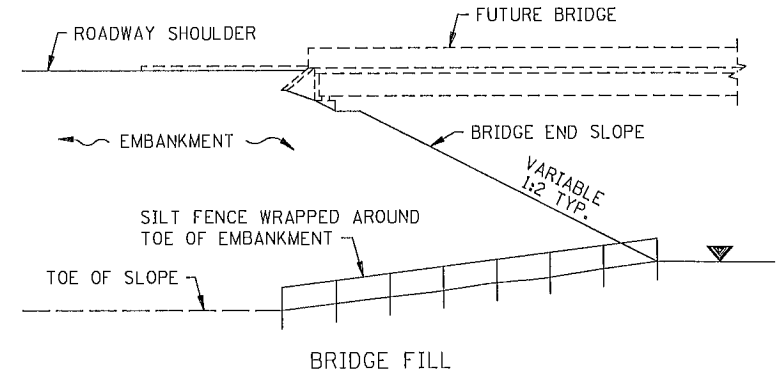

DESIGN GUIDELINES:
WATER COURSE FLOW VELOCITY: STAGNANT
CONTRIBUTING SLOPE AREA: 1/2 ACRE

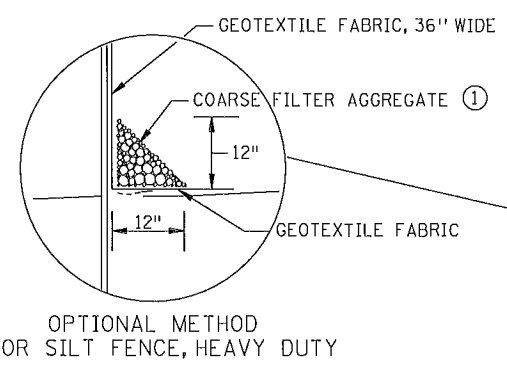

OPTIONAL METHOD
FOR SILT FENCE, HEAVY DUTY

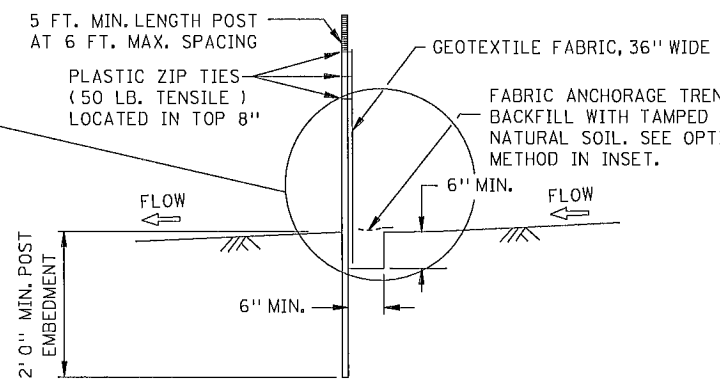

SILT FENCE, HEAVY DUTY
(HAND INSTALLED)
DESIGN GUIDELINES:
TO PROTECT AREAS FROM SHEET FLOW.
MAXIMUM CONTRIBUTING AREA: 1 ACRE.

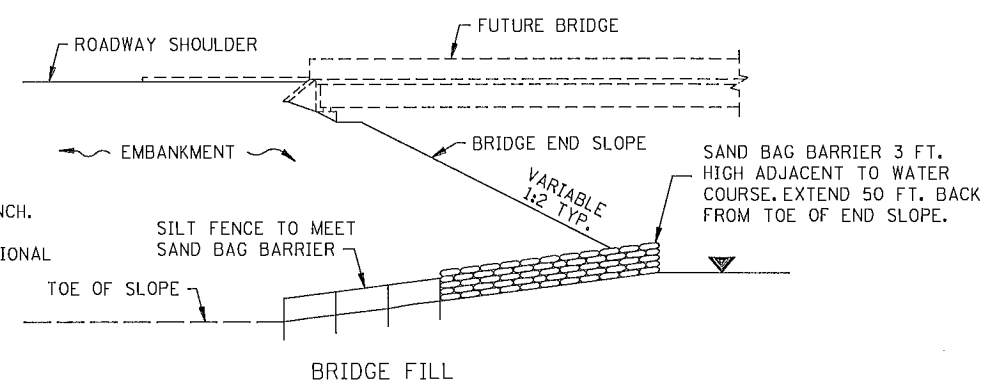

DESIGN GUIDELINES:
WATER COURSE FLOW VELOCITY: 1 TO 7 FT./SEC.
CONTRIBUTING SLOPE AREA: 1 ACRE

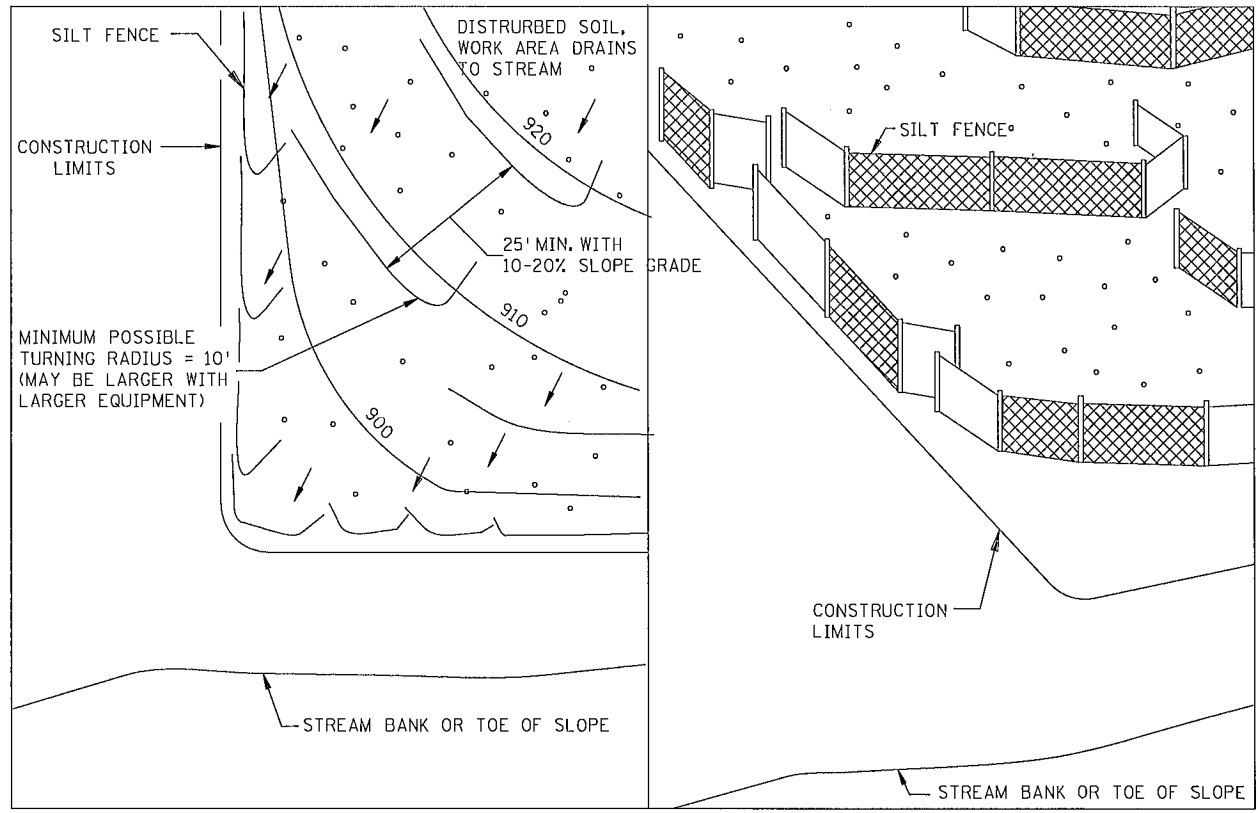

SILT FENCE, J-HOOK INSTALLATION

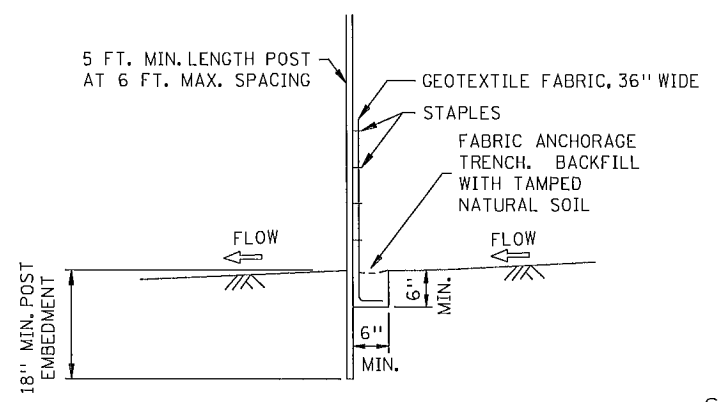

SILT FENCE, PREASSEMBLED
DESIGN GUIDELINES:
TO PROTECT AREAS FROM SHEET FLOW.
MAXIMUM CONTRIBUTING AREA: 1 ACRE.

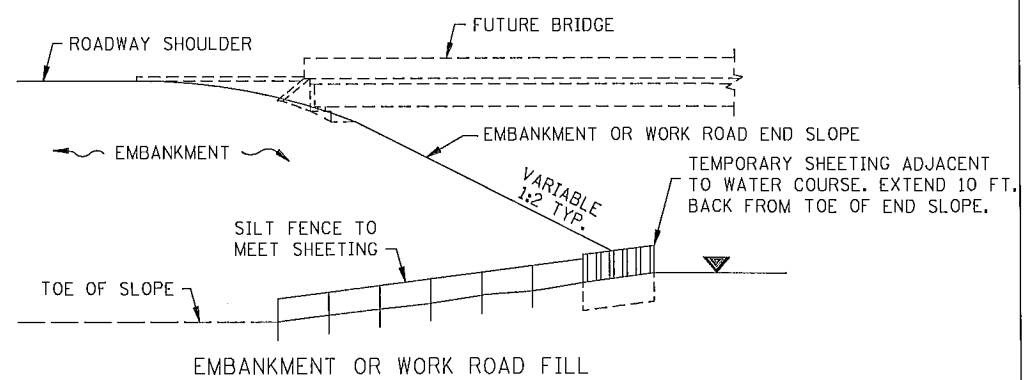

DESIGN GUIDELINES:
WATER COURSE FLOW VELOCITY: 8 TO 15 FT./SEC.
CONTRIBUTING SLOPE AREA: 3 ACRES
SILT FENCE AT BRIDGE EMBANKMENT ADJACENT TO WATER

NOTES:
SEE SPECS. 2573, 3149 & 3886.
① COARSE FILTER AGGREGATE (SPEC. 3149) SHALL BE INCIDENTAL.

DISTRICT #: \$@DISTRICT@\$
USER NAME: \$@USER\$NAME@\$
PATH & FILENAME: \$@PATH\$FILENAME\$\$\$
FILE NAME: \$@FILENAME@\$
@FILENAME@

STANDARD SHEET NO. 5-297.408 (1 OF 2)	TITLE: TEMPORARY SEDIMENT CONTROL SILT FENCE
STANDARD APPROVED: SEPTEMBER 27, 2006	
S.P. 002-621-010	SHEET NO. 70 OF 147 SHEETS

NOTES:

- Shape of back of buttress may vary as long as poured against firm undisturbed earth.
- Dimension C1, C2, C3 should be large enough to make angle θ equal to or larger than 45°.
- Dimension A1, A2, A3 should be as large as possible without interfering with MJ bolts.
- $\theta = 45^\circ$ Minimum.
- Place polyethylene between concrete & pipe.

PIPE SIZE	BUTTRESS DIMENSIONS					
	22 1/2° BEND		45° BEND		90° BEND	
	B1	D1	B2	D2	B3	D3
6"	1'-5"	1'-5"	1'-5"	1'-5"	2'-1"	1'-6"
8"	1'-5"	1'-5"	2'-1"	1'-6"	2'-8"	2'-0"
12"	1'-10"	1'-10"	3'-4"	2'-0"	4'-9"	2'-6"
16"	3'-0"	2'-0"	3'-10"	3'-0"	6'-2"	3'-6"
20"	3'-6"	2'-8"	5'-6"	3'-4"	8'-4"	4'-0"
24"	4'-4"	3'-0"	6'-10"	3'-10"	9'-8"	5'-0"
30"	-	-	9'-3"	6'-0"	17'-0"	6'-0"

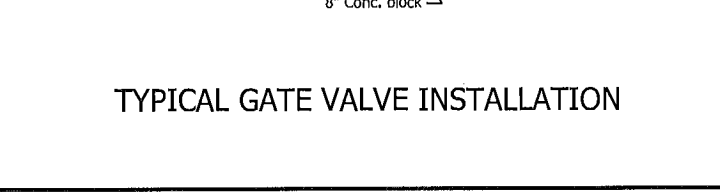
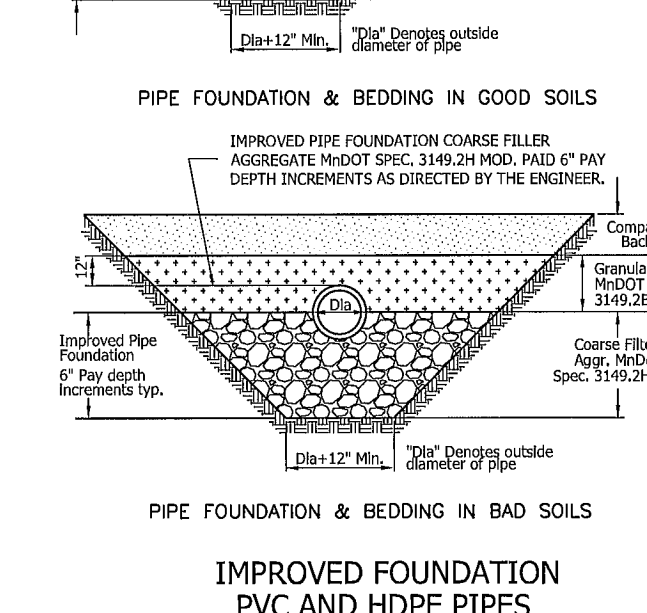
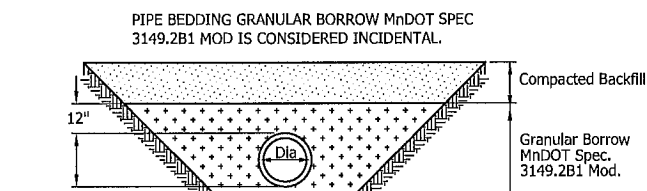
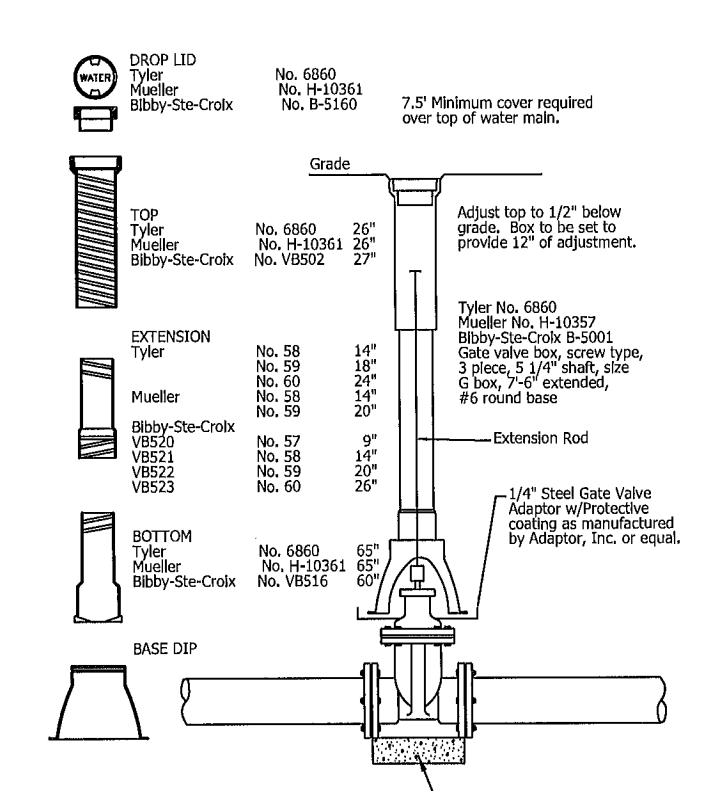
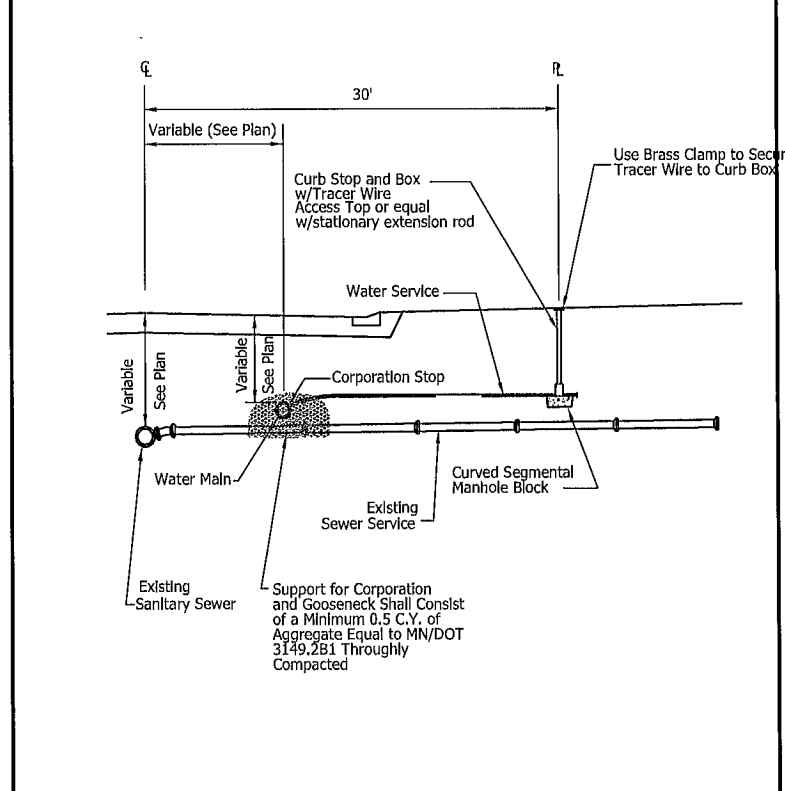
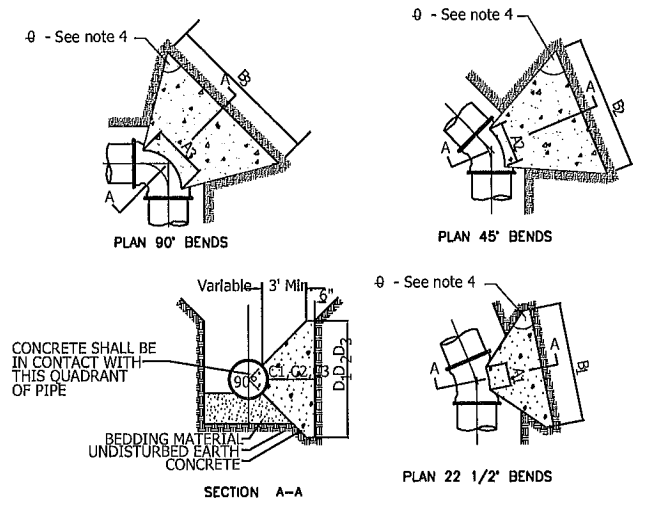

CITY OF CENTERVILLE				
SPEC NO.	DESCRIPTION	UNIT	EST. QUAN1	ACT. QUAN.
2101.502	CLEARING	EA	137	
2101.507	GRUBBING	EA	137	
2104.501	REMOVE PIPE CULVERT	LF	60	
2104.501	REMOVE SEWER PIPE (SANITARY)	LF	60	
2104.523	SALVAGE CASTING	EA	1	
2104.523	SALVAGE MANHOLE	EA	1	
2105.604	GEOTEXTILE FABRIC TYPE IV	SY	134	
2501.511	48" RC PIPE CULVERT CLASS V	LF	72	
2501.515	48" RC PIPE APRON	EA	2	
2501.515	54" RC PIPE APRON	EA	1	
2503.511	18" RC PIPE SEWER CLASS III	LF	316	
2504.511	48" RC PIPE SEWER CLASS III	LF	1700	
2505.511	54" RC PIPE SEWER CLASS III	LF	42	
2503.602	CONNECT TO EXISTING MANHOLE (SANITARY)	EA	4	
2503.603	SEWER INSPECTION	LF	1283	
2503.603	SANITARY SEWER SERVICE	LF	366	
2503.603	8" PVC PIPE SEWER	LF	1223	
2503.603	12" PVC PIPE SEWER	LF	60	
2504.602	CONNECT TO EXISTING WATER MAIN	EA	4	
2504.602	8"x6" REDUCER	EA	2	
2504.602	1" CORPORATION STOP	EA	9	
2504.602	INSTALL HYDRANT & VALVE	EA	2	
2504.602	6"x6" TEE FITTING	EA	1	
2504.602	8"x6" TEE FITTING	EA	2	
2504.602	8"x8" TEE	EA	1	
2504.602	8" PIPE BEND 45 DEGREE	EA	4	
2504.602	12" X 8" REDUCER	EA	1	
2504.602	6" GATE VALVE AND BOX	EA	2	
2504.602	8" GATE VALVE & BOX	EA	1	
2504.602	6" MEGALUG	EA	15	
2504.602	8" MEGALUG	EA	16	
2504.602	12" MEGALUG	EA	1	
2504.602	1" CURB STOP AND BOX	EA	9	
2504.603	WATER SERVICE	LF	175	
2504.603	HYDRANT RISER	LF	2	
2504.603	6" PVC WATERMAIN	LF	550	
2504.603	8" PVC WATER MAIN	LF	1145	
2105.511	COMMON CHANNEL EXCAVATION	LS	1	
2505.606	PIPELINE CASING FILLER	GAL	6500	
2506.502	CONSTRUCT DRAINAGE STRUCTURE DESIGN 48-4020	LF	5.4	
2506.502	CONSTRUCT DRAINAGE STRUCTURE DESIGN 54-4020	LF	3.44	
2506.502	CONSTRUCT DRAINAGE STRUCTURE DESIGN 66-4020	LF	4.51	
2506.502	CONSTRUCT DRAINAGE STRUCTURE DESIGN 72-4020	LF	74.91	
2506.502	CONSTRUCT DRAINAGE STRUCTURE DESIGN 78-4020	LF	13.94	
2506.502	CONSTRUCT DRAINAGE STRUCTURE DESIGN 102-4020	LF	16.2	
2506.502	CONSTRUCT DRAINAGE STRUCTURE DESIGN 120-4020	LF	9.13	
2506.521	INSTALL CASTING	EA	1	
2506.602	INSTALL MANHOLE	EA	1	
2506.602	DRAINAGE STRUCTURE DESIGN SPECIAL	EA	5	
2506.516	CASTING ASSEMBLY A	EA	2	
2506.516	CASTING ASSEMBLY B	EA	12	
2506.516	CASTING ASSEMBLY F	EA	1	
2511.501	RANDOM RIP RAP CLASS III	CY	76	
2511.501	RANDOM RIP RAP CLASS IV	CY	62	
2573.540	FILTER LOG TYPE ROCK LOG	LF	110	
2575.502	SEED MIXTURE 310	LB	13	
2575.523	EROSION CONTROL BLANKETS CATEGORY 4	SY	1800	

NO	DATE	BY	CKD	APPR	REVISION
1	7-22-2014	JWL	MRS		STATE AID COMMENTS

NAME: \\us1291-f01\workgroup\1930\active\193801639\CAD\DWG\PLAN SHTS\0262110_detail1.dgn 7/22/2014 1:37:42 PM

I HEREBY CERTIFY THAT THIS PLAN WAS PREPARED BY ME OR UNDER MY DIRECT SUPERVISION AND THAT I AM A DULY LICENSED PROFESSIONAL ENGINEER UNDER THE LAWS OF THE STATE OF MINNESOTA.

PRINT NAME: MARK R. STATZ

SIGNATURE: *Mark R. Statz*

DATE: 7-22-2014 LICENSE NO. 42717

DRAWN BY: JWL DATE: 03/24/2014

DESIGN BY: PE DATE: 03/24/2014

CHECKED BY: MRS DATE: 03/24/2014

CITY OF CENTERVILLE

CONSTRUCTION DETAILS

S.A.P. 002-621-010

Sheet 71 of 147 Sheets

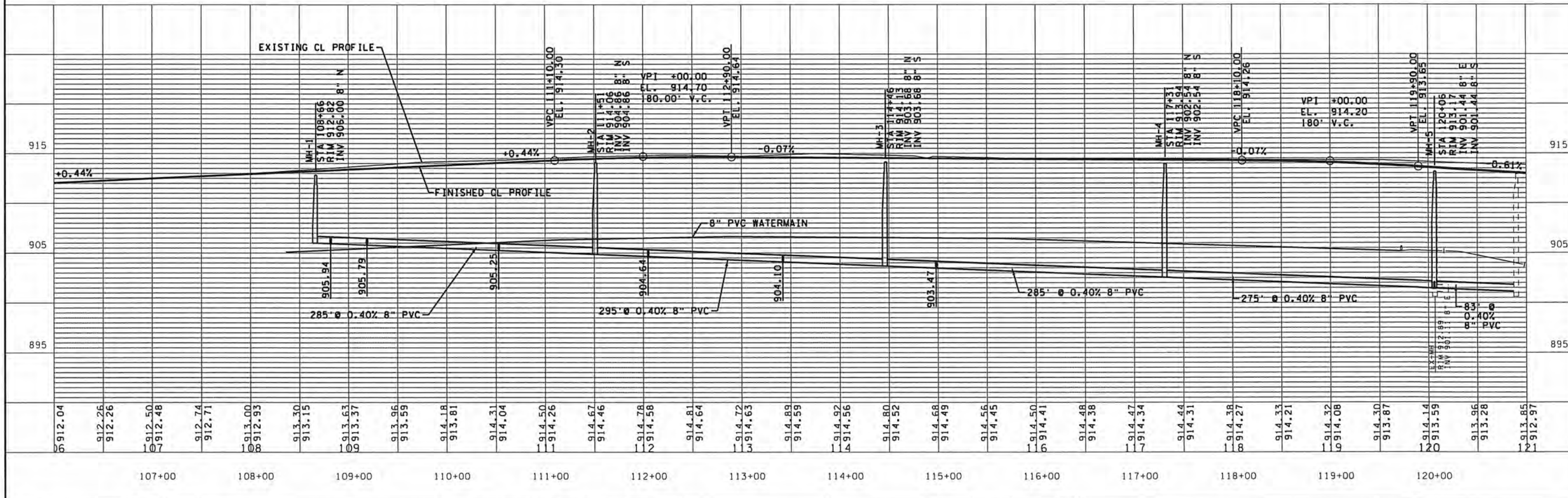
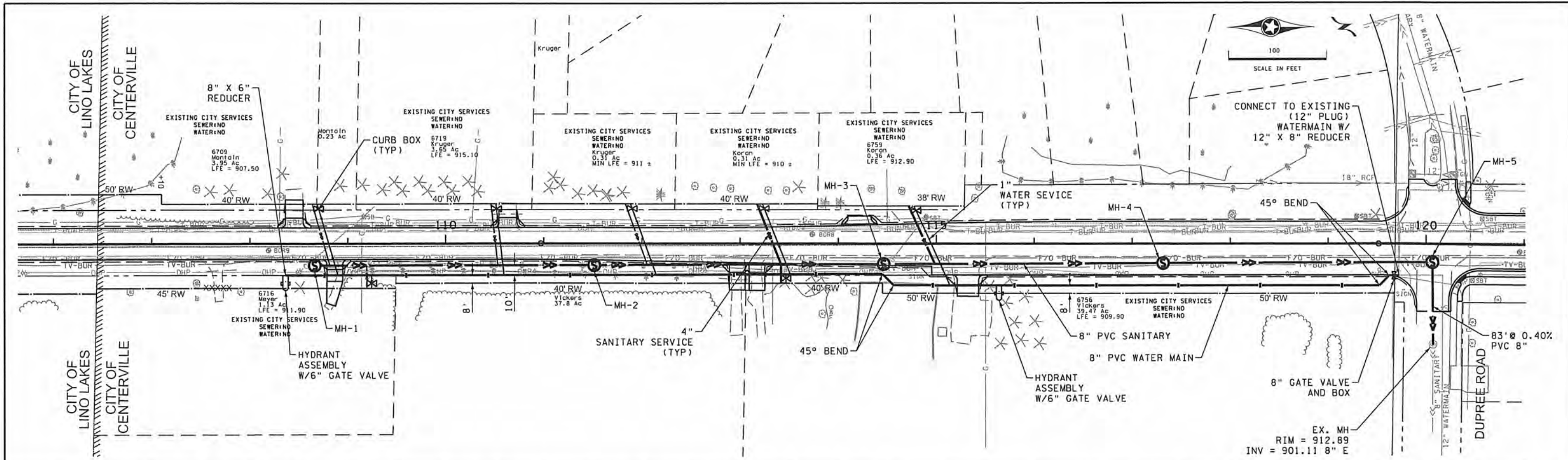

NO	DATE	BY	CKD	APPR	REVISION

I HEREBY CERTIFY THAT THIS PLAN WAS PREPARED BY ME OR UNDER MY DIRECT SUPERVISION AND THAT I AM A DULY LICENSED PROFESSIONAL ENGINEER UNDER THE LAWS OF THE STATE OF MINNESOTA.

PRINT NAME: MARK R. STATZ
 SIGNATURE: *[Signature]*
 DATE: 7/14/14 LICENSE NO. 42717

DRAWN BY: JWL DATE 05/15/2014
 DESIGN BY: PE DATE 05/15/2014
 CHECKED BY: MRS DATE 05/15/2014

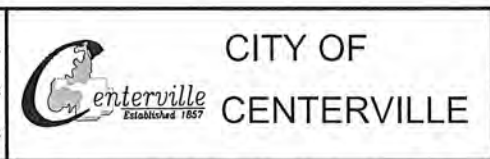

CITY OF CENTERVILLE
 S.A.P. 002-621-010

CITY SEWER AND WATER
 STA 106+00 TO 121+00
 Sheet 72 of 147 Sheets

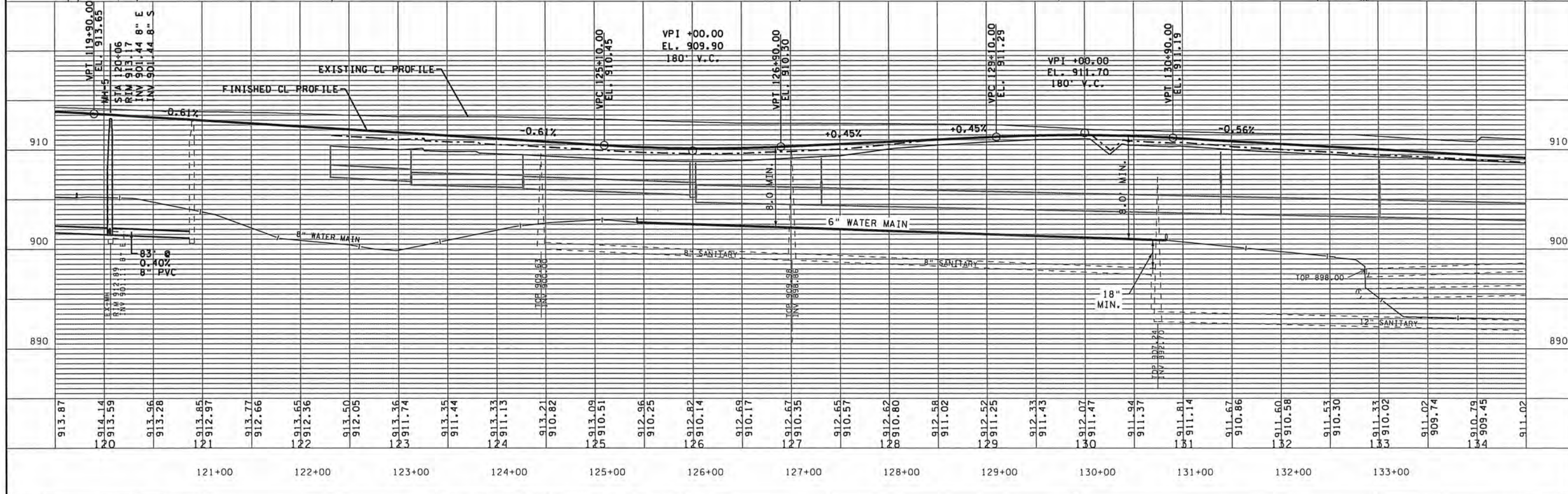
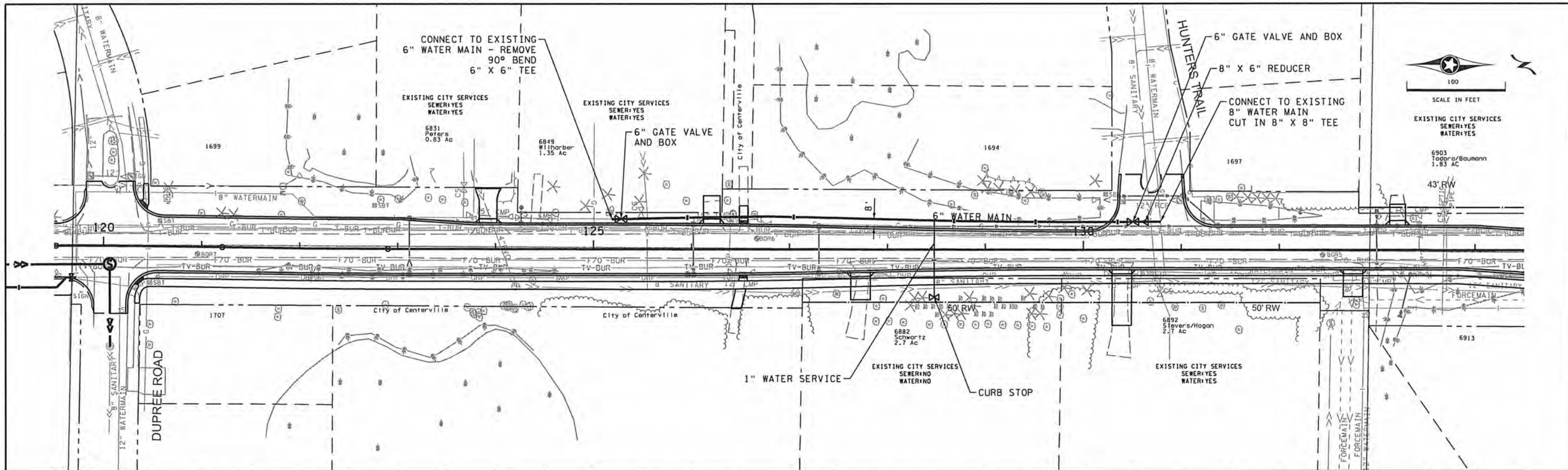

NO	DATE	BY	CKD	APPR	REVISION

I HEREBY CERTIFY THAT THIS PLAN WAS PREPARED BY ME OR UNDER MY DIRECT SUPERVISION AND THAT I AM A DULY LICENSED PROFESSIONAL ENGINEER UNDER THE LAWS OF THE STATE OF MINNESOTA.
 PRINT NAME: MARK B. STATZ
 SIGNATURE: *[Signature]*
 DATE: 7/14/14 LICENSE NO. 42717

DRAWN BY: JWJ DATE: 03/24/2014
 DESIGN BY: PE DATE: 03/24/2014
 CHECKED BY: MRS DATE: 03/24/2014

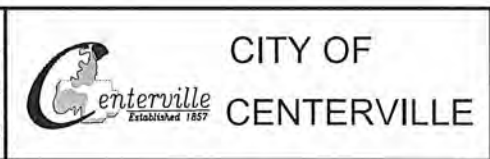

CITY SEWER AND WATER
 STA 119+50 TO 134+50
 S.A.P. 002-621-010
 Sheet 73 of 147 Sheets

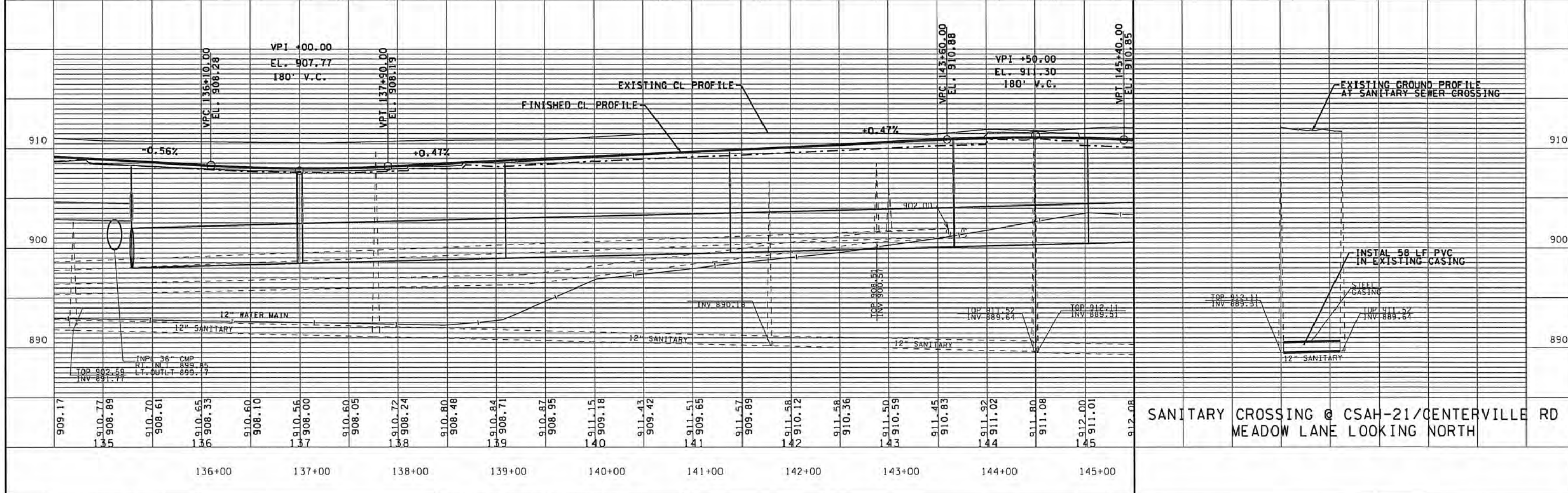
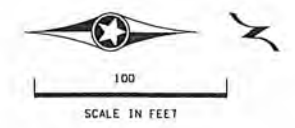
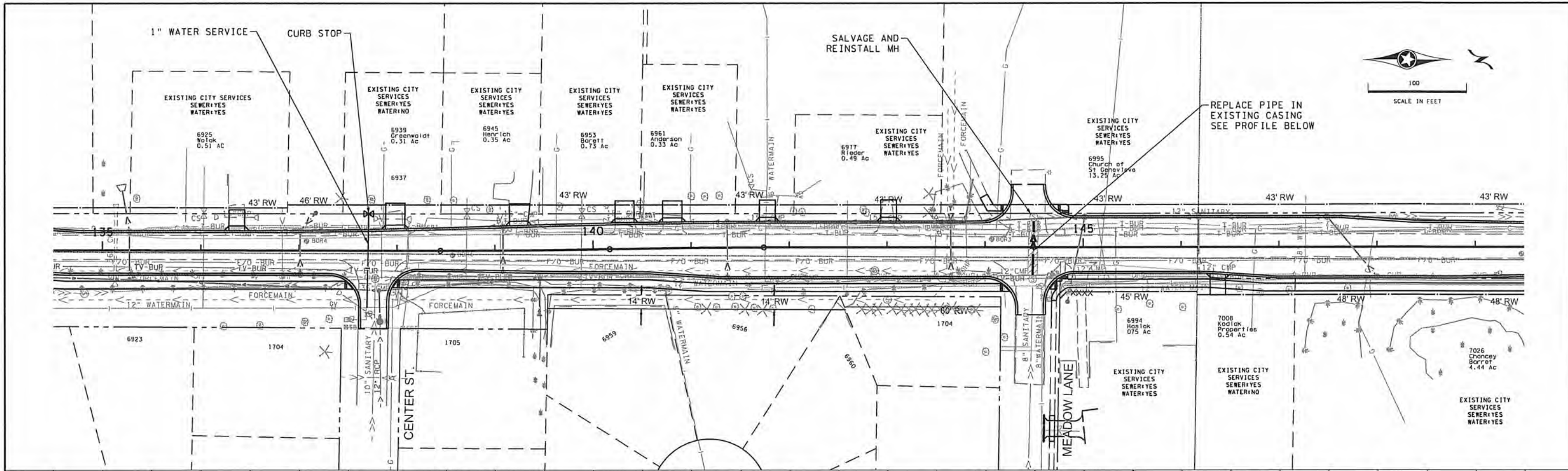

I HEREBY CERTIFY THAT THIS PLAN WAS PREPARED BY ME OR UNDER MY DIRECT SUPERVISION AND THAT I AM A DULY LICENSED PROFESSIONAL ENGINEER UNDER THE LAWS OF THE STATE OF MINNESOTA. PRINT NAME: <u>MARK R. STATZ</u> SIGNATURE: <i>[Signature]</i> DATE: <u>7/14/14</u> LICENSE NO. <u>42717</u>					DRAWN BY: <u>JWL</u> DATE: <u>03/24/2014</u> DESIGN BY: <u>PE</u> DATE: <u>03/24/2014</u> CHECKED BY: <u>MRS</u> DATE: <u>03/24/2014</u>		 CITY OF CENTERVILLE		CITY SEWER AND WATER STA <u>134+50</u> TO <u>149+50</u> S.A.P. 002-621-010 Sheet <u>74</u> of <u>147</u> Sheets	
NO	DATE	BY	CKD	APPR	REVISION					
NAME: \\us1291-01\workgroup\1938\active\193801639\CAD\DWG\PLAN SHTS\0262110_UT13.dgn 7/8/2014 1:04:53 PM										

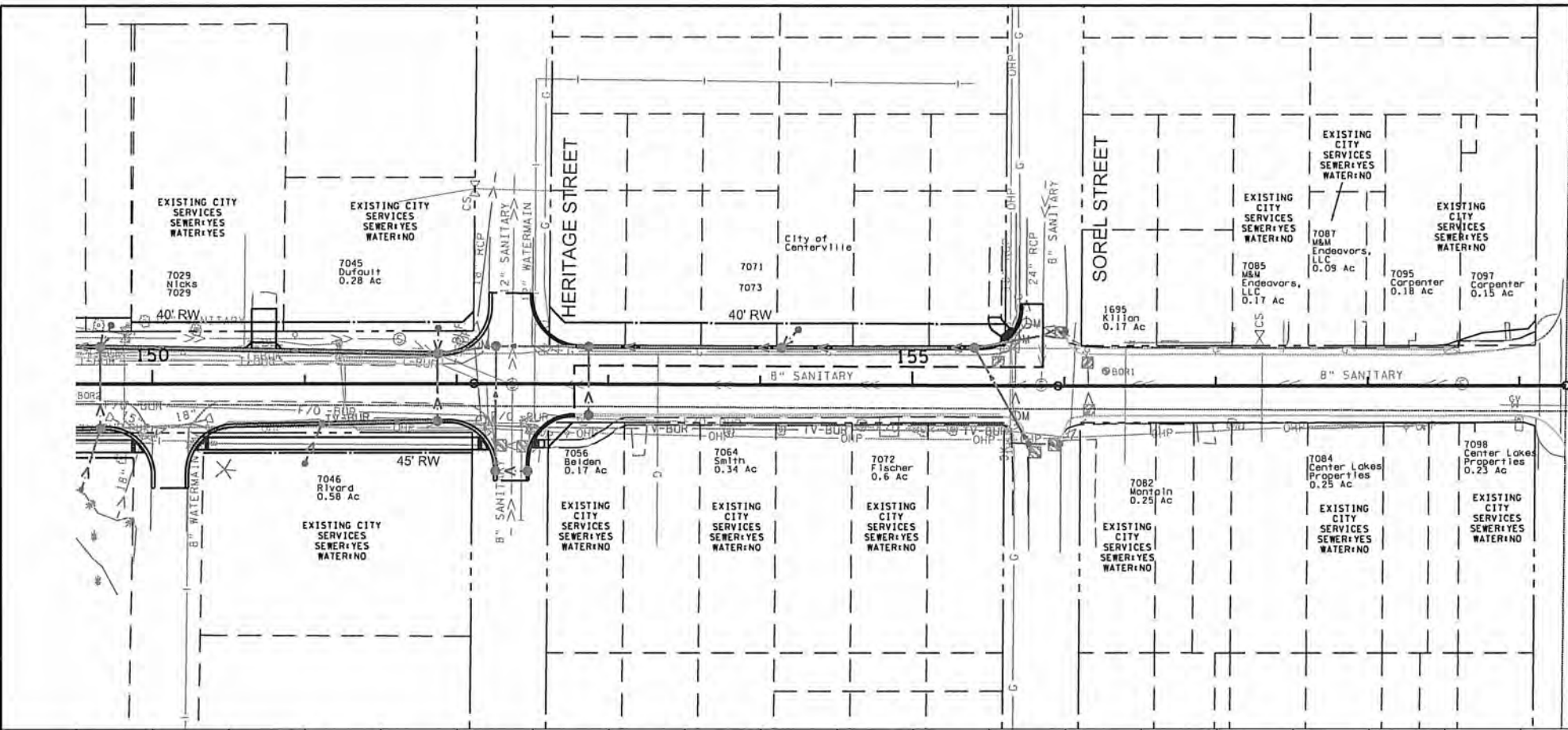
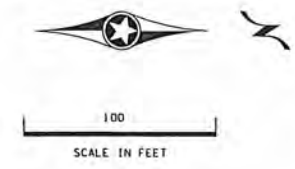

MAIN STREET (C.S.A.H. NO. 14)

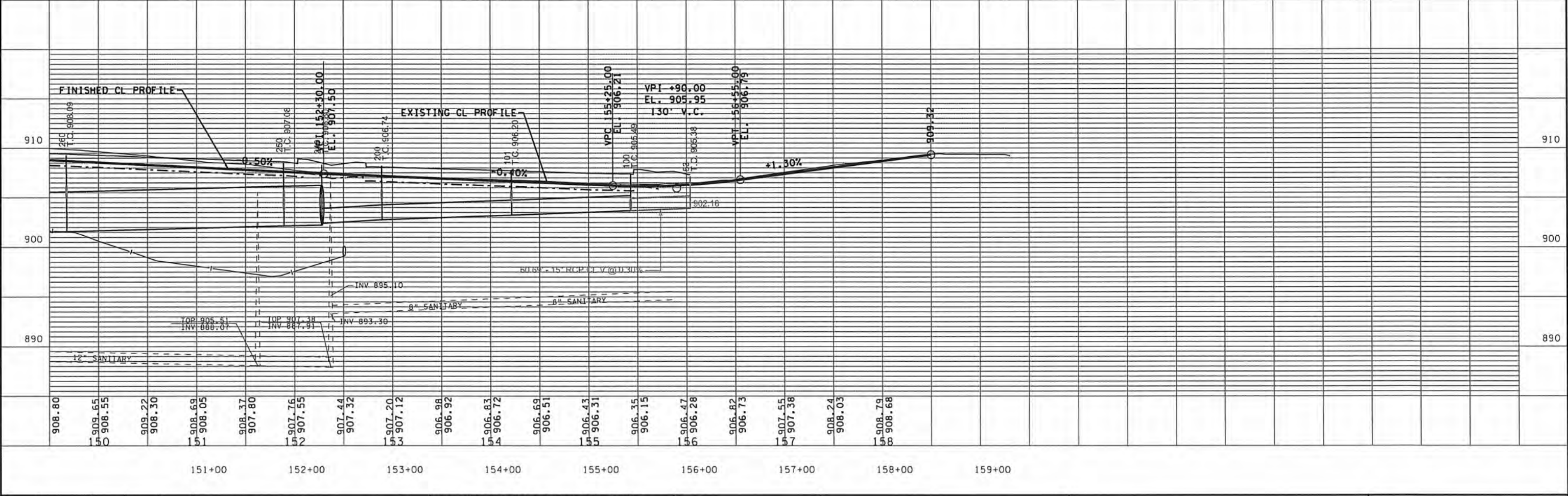

NO	DATE	BY	CKD	APPR	REVISION

NAME: \\us1291-f01\workgroup\19380\act\ve\19380\639\CAD\DWG\PLAN SHTS\0262110_UT14.dgn 7/8/2014 1:04:54 PM



I HEREBY CERTIFY THAT THIS PLAN WAS PREPARED BY ME OR UNDER MY DIRECT SUPERVISION AND THAT I AM A DULY LICENSED PROFESSIONAL ENGINEER UNDER THE LAWS OF THE STATE OF MINNESOTA.
 PRINT NAME: MARK R. STATZ
 SIGNATURE: *[Signature]*
 DATE: 7/17/14 LICENSE NO. 42717

DRAWN BY: JWL DATE: 03/24/2014
 DESIGN BY: PE DATE: 03/24/2014
 CHECKED BY: MRS DATE: 03/24/2014

CITY OF

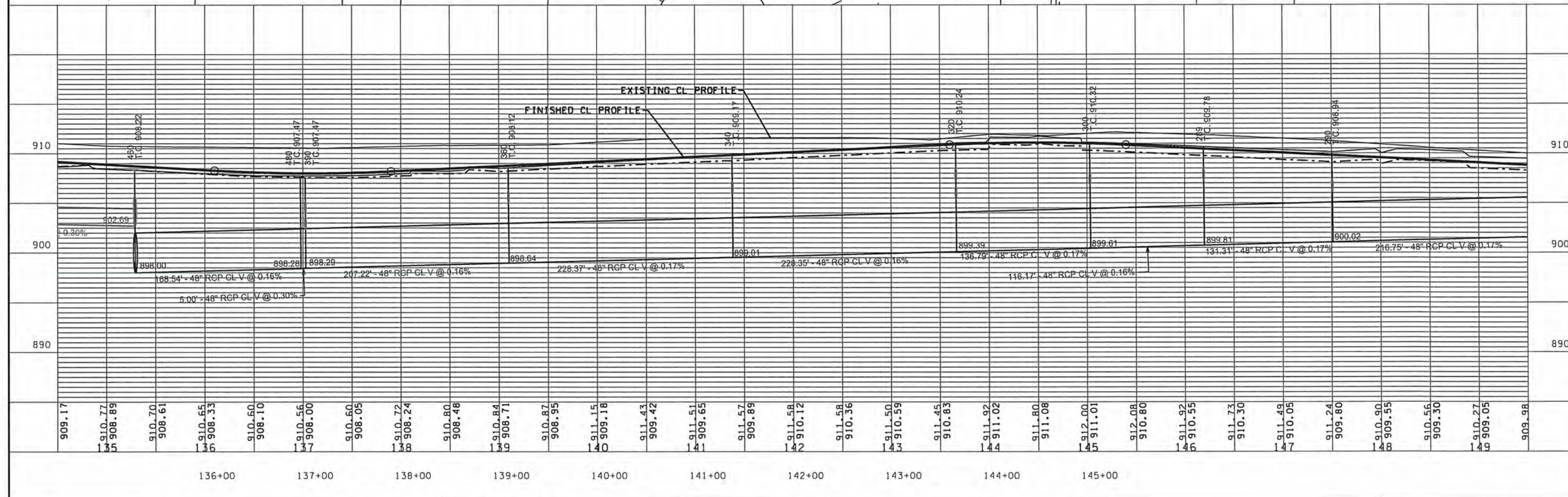
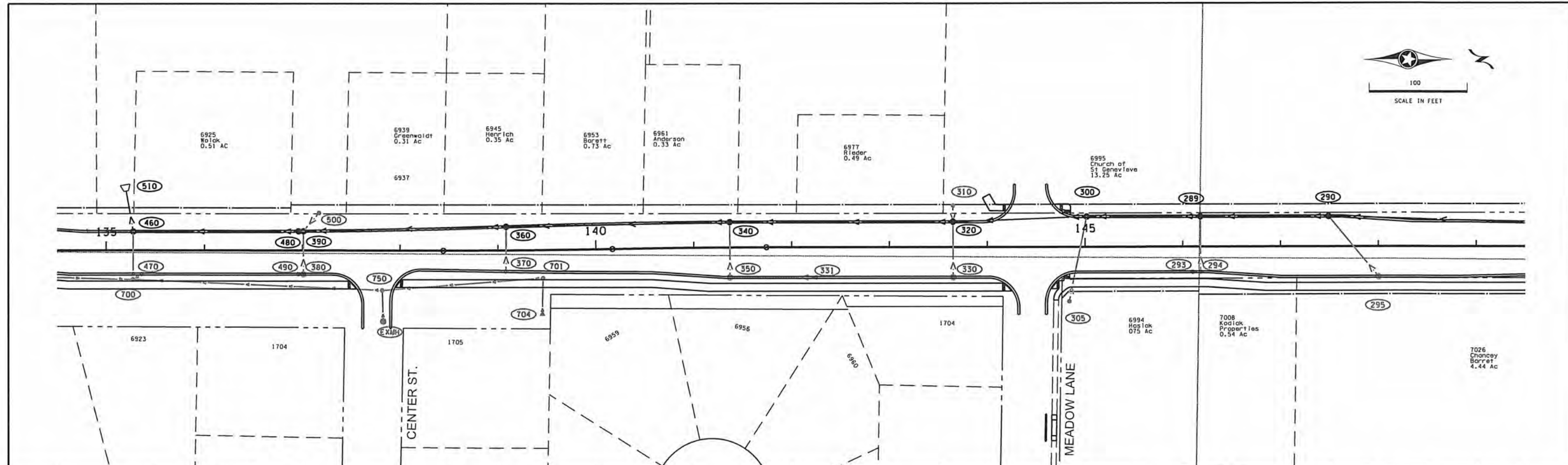
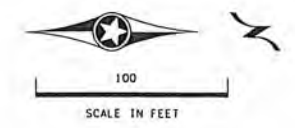
CENTERVILLE

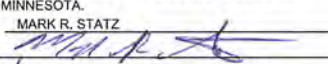
CITY SEWER AND WATER
 STA 149+50 TO 159+00
 S.A.P. 002-621-010
 Sheet 75 of 147 Sheets

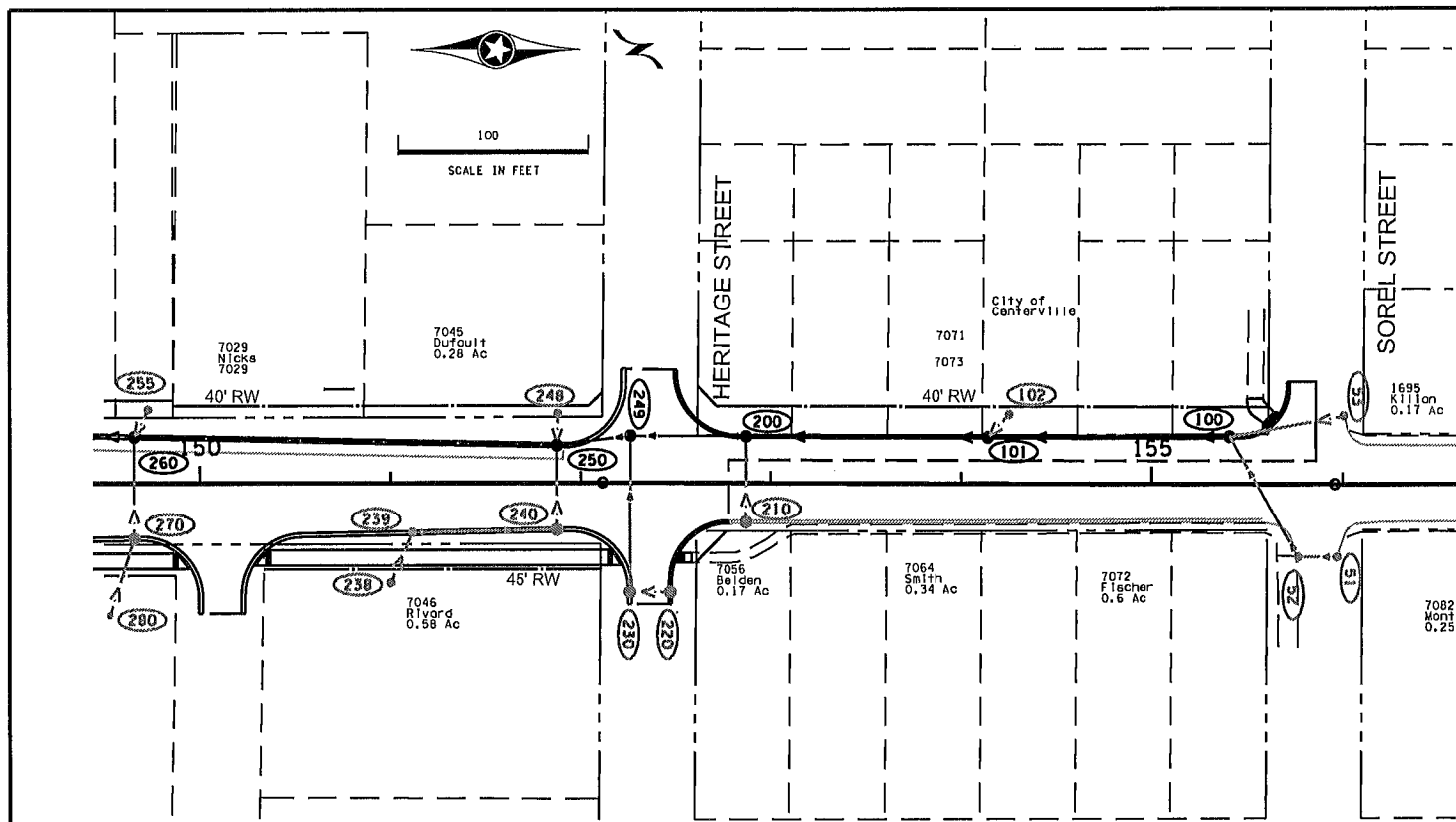

I HEREBY CERTIFY THAT THIS PLAN WAS PREPARED BY ME OR UNDER MY DIRECT SUPERVISION AND THAT I AM A DULY LICENSED PROFESSIONAL ENGINEER UNDER THE LAWS OF THE STATE OF MINNESOTA. PRINT NAME: <u>MARK R. STATZ</u> SIGNATURE:  DATE: <u>7/14/14</u> LICENSE NO. <u>42717</u>					DRAWN BY: <u>JWL</u> DATE: <u>03/24/2014</u> DESIGN BY: <u>PE</u> DATE: <u>03/24/2014</u> CHECKED BY: <u>MRS</u> DATE: <u>03/24/2014</u>		 CITY OF CENTERVILLE		CITY STORM SEWER STA <u>134+50</u> TO <u>149+50</u> S.A.P. 002-621-010 Sheet <u>76</u> of <u>147</u> Sheets	
NO	DATE	BY	CKD	APPR	REVISION					
NAME: \\us1291-f01\workgroup\1938\lact\193801639\CAD\DWG\PLAN SHTS\0262110_STM3.dgn 7/8/2014 1:04:55 PM										



STRUCTURE NO.	FLOWS FROM	FLOWS TO	ALIGN	CENTER OF CASTING				TYPE	DESIGN	DRAINAGE STRUCTURES						CASTING ASSEMBLY TYPE	STEPS REQ'D	STORM SEWER						NOTES		
				STATION	OIB	L/R	48-4020			64-4020	66-4020	72-4020	78-4020	102-4020	120-4020			TOP OF CASTING ELEVATION	OUTLET ELEVATION	DOWN STREAM INLET	SLOPE %	PIPE SIZE	18" RCP CL III		48" RCP CL III	54" RCP CL III
100	101	CL 21	155+40.80	24.50	L	CB	64-4020								B	YES	905.49	902.00	901.66	0.28	18		121.37			4
101	200	CL 21	154+19.48	24.00	L	CB	66-4020		3.44						B	YES	906.20	901.66	901.29	0.28	18	132.39			4	
200	249	CL 21	152+87.10	24.25	L	CB	48-4020	5.40							B	YES	906.74	901.29	901.00	0.47	18	61.3			4	
230	249	CL 21	152+25.60	55.92	R	CB	72-4020				5.98				B	YES	907.03	901.00	900.80	0.25	48				4	
249	250	CL 21	151+11.35	21.00	L	MH	102-4020					6.28	6.95		F	YES	906.80	900.80	900.75	0.13	48		35.8		4	
250	260	CL 21	151+87.40	19.46	L	CB	78-4020								B	YES	907.08	900.75	900.38	0.17	48		221.66		4	
260	290	CL 21	149+65.90	24.00	L	CB	78-4020								B	YES	906.09	900.38	900.02	0.17	48		216.75		4	
289	300	CL 21	146+17.90	30.50	L	CB	78-4020				9.92				B	YES	906.78	899.81	899.61	0.16	48		116.17		4	
290	289	CL 21	147+49.20	30.50	L	CB	120-4020				8.87				B	YES	906.84	900.02	899.61	0.17	48		131.31		4	
300	320	CL 21	145+01.75	30.50	L	CB	84-4020				10.66				B	YES	910.32	899.61	899.39	0.17	48		135.79		4	
320	340	CL 21	143+65.05	25.50	L	CB	78-4020				10.80				B	YES	910.24	899.39	899.01	0.16	48		228.35		4	
340	360	CL 21	141+36.80	25.50	L	CB	78-4020				10.11				B	YES	909.17	899.01	898.64	0.17	48		228.37		4	
360	390	CL 21	139+06.50	23.97	L	CB	78-4020				9.43				B	YES	908.12	898.84	898.29	0.16	48		207.22		4	
390	480	CL 21	137+01.20	18.37	L	CB	120-4020							9.13	A	YES	907.47	898.29	898.28	0.30	48		5		4	
460	510	CL 21	135+27.50	18.00	L	CB	102-4020							10.17	B	YES	908.22	898.00	897.67	0.31	64			42	4	
460	460	CL 21	136+96.16	18.37	L	CB	72-4020				9.14				A	YES	907.47	898.28	898.00	0.16	48		166.64	42.0	4	
PROJECT TOTAL									5.40	3.44	4.61		9.14	13.94	16.12	9.13						315.1	1699.9	42.0		

- NOTES:
- EX MH TO BE REMOVED. CONNECT TO EXISTING PIPE AND EXTEND TO PROPOSED MH 750
 - STA. 91+25.11 TO 92+66.80, FURNISH AND INSTALL 14" PVC BY ANOKA COUNTY HIGHWAY DEPARTMENT
 - 4" CASTING TO BE USED INSTEAD OF AN 8" CASTING
 - DESIGNED BY CITY OF CENTERVILLE. FOR MORE INFORMATION SEE CITY STORM SEWER SHEETS 75 TO 78
- GENERAL NOTES:
- R-3448C NEENAH CASTING ASSEMBLIES OR EAST JOROAN IRON WORKS PRODUCT NO. 00500050001 OR APPROVED EQUALS.
 - STATION AND OFFSET FOR EACH STRUCTURE GIVEN AT CENTER OF GRATE/CASTING FOR CATCH BASINS AND MANHOLES, AND AT APRON END FOR APRONS. INVERT ELEVATIONS GIVEN AT CENTER OF STRUCTURE OR END OF APRON.
 - IF STEPS REQUIRED, STRUCTURE TO INCLUDE MANHOLE STEPS 16" ON CENTER. SEE MN/DOT STANDARD PLATE 4180.
 - PIPE LENGTH DOES NOT INCLUDE APRON.

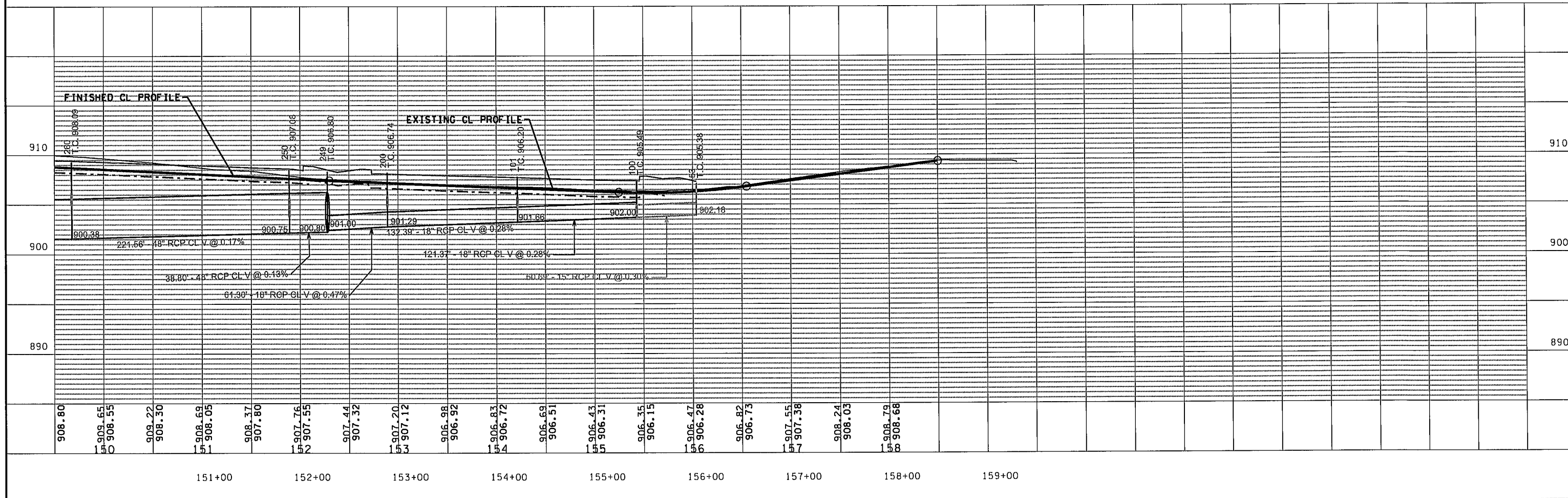

NO	DATE	BY	CKD	APPR	REVISION
1	7-22-2014	JWL	MRS		STATE AID COMMENTS

NAME: \\us1291-f01\workgroup\1938\act\file\193801639\CAD\DWG\PLAN SHTS\0262110_STM4.dgn 7/22/2014 1:37:51 PM

I HEREBY CERTIFY THAT THIS PLAN WAS PREPARED BY ME OR UNDER MY DIRECT SUPERVISION AND THAT I AM A DULY LICENSED PROFESSIONAL ENGINEER UNDER THE LAWS OF THE STATE OF MINNESOTA.

PRINT NAME: MARK R. STATZ
 SIGNATURE: *Mark R. Statz*
 DATE: 7-22-2014 LICENSE NO. 42717

DRAWN BY: JWL DATE: 03/24/2014
 DESIGN BY: PE DATE: 03/24/2014
 CHECKED BY: MRS DATE: 03/24/2014



CITY OF CENTERVILLE
 S.A.P. 002-621-010

CITY STORM SEWER
 STA 149+50 TO 159+00
 Sheet 77 of 147 Sheets

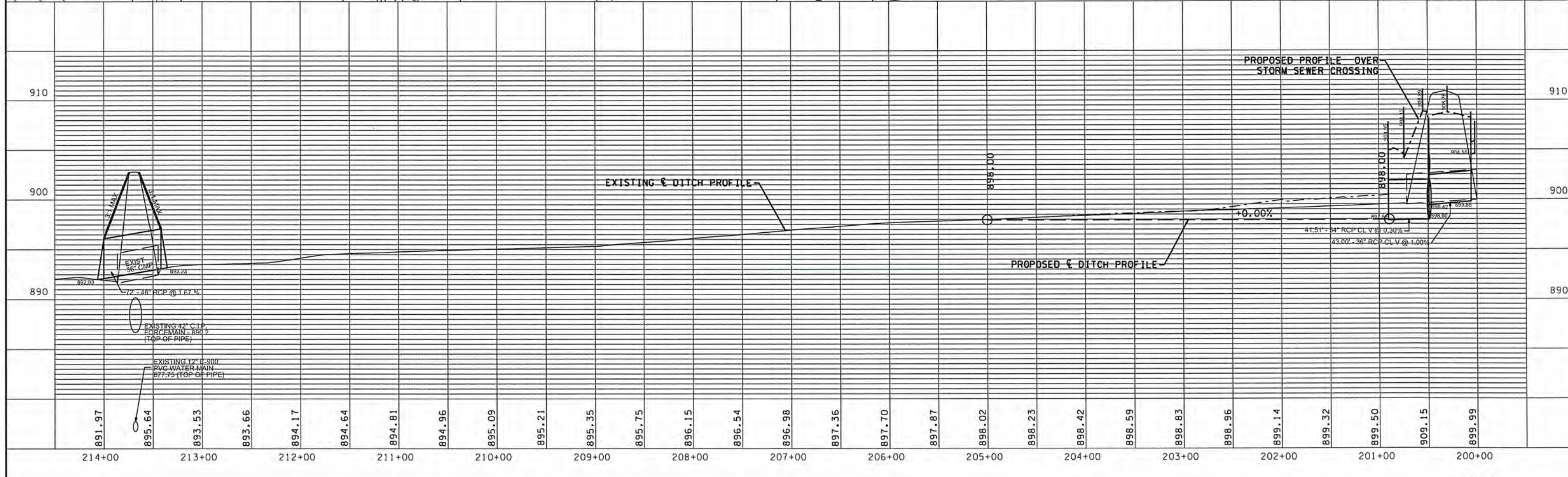
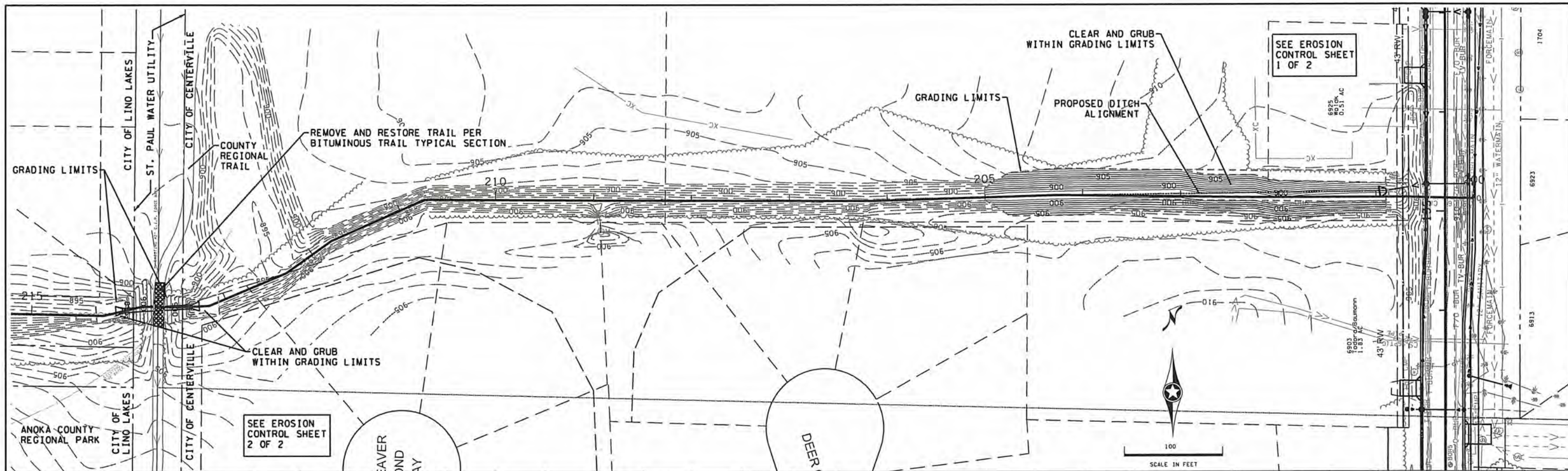

1 OF 1

NO	DATE	BY	CKD	APPR	REVISION

NAME: \\us1291-01\workgroup\1938\active\193801639\CAD\DWG\PLAN_SHTS\0262110_DIT1.dgn 7/8/2014 1:04:57 PM

I HEREBY CERTIFY THAT THIS PLAN WAS PREPARED BY ME OR UNDER MY DIRECT SUPERVISION AND THAT I AM A DULY LICENSED PROFESSIONAL ENGINEER UNDER THE LAWS OF THE STATE OF MINNESOTA.

PRINT NAME: MARK B. STATZ
 SIGNATURE: *Mark B. Statz*
 DATE: 7/14/14 LICENSE NO. 42717

DRAWN BY: JWL DATE: 03/24/2014
 DESIGN BY: PE DATE: 03/24/2014
 CHECKED BY: MRS DATE: 03/24/2014



S.A.P. 002-621-010

DITCH PLAN AND PROFILE
 STA 215+00 TO 200+00
 Sheet 78 of 147 Sheets



Notes
 1) DRAINTILE FROM BALL FIELDS (6" DIA.) DAYLIGHTS INTO DITCH TWO LOCATIONS. PROTECT THESE OUTLETS (INCIDENTAL). CITY WILL MARK THEIR LOCATION IN THE FIELD.

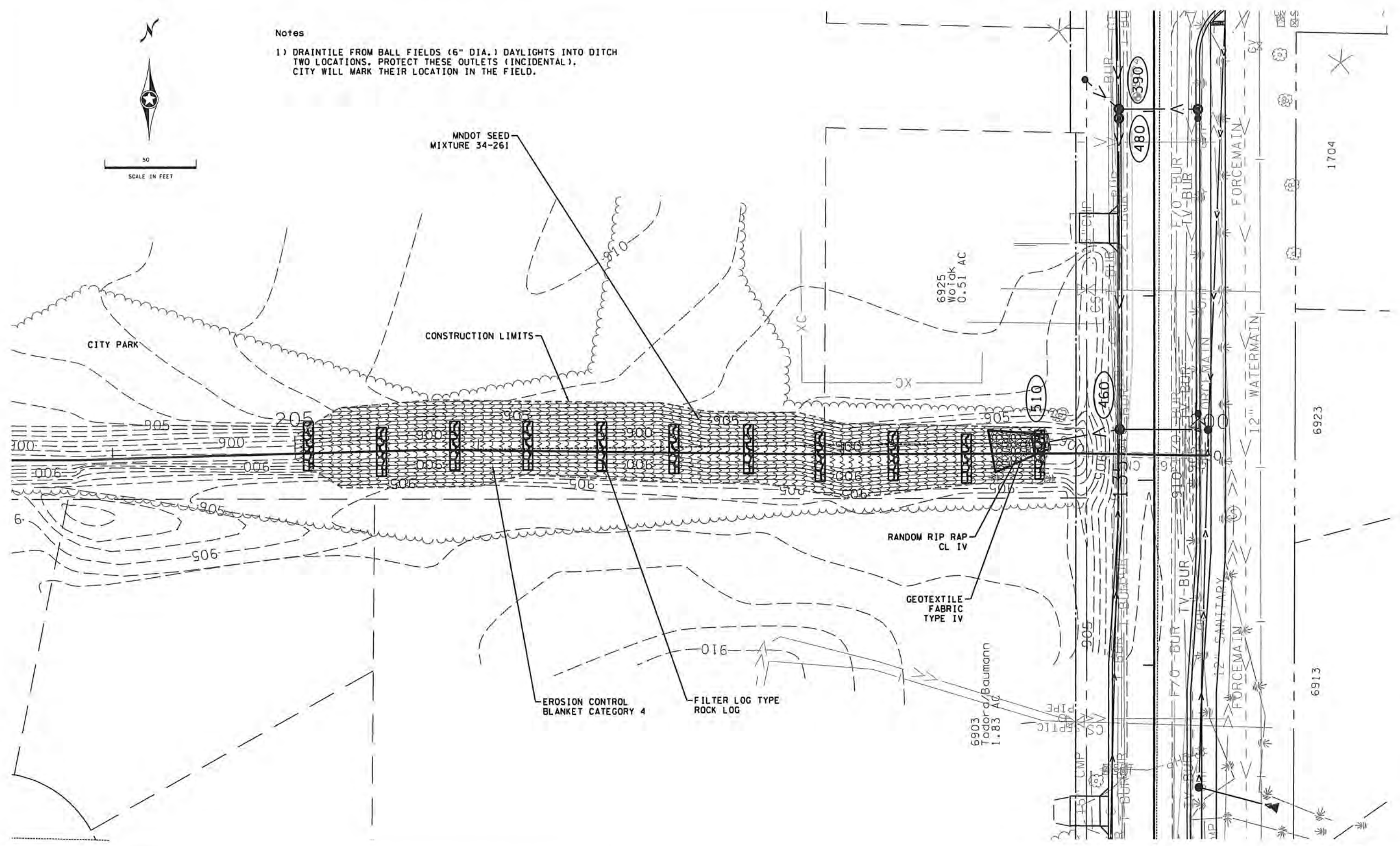

NO	DATE	BY	CKD	APPR	REVISION

NAME: \\us1291-01\work\group1938\active\193801639\CAD\DWG\PLAN SHTS\0262110_EC1.dgn 7/8/2014 1:04:58 PM

I HEREBY CERTIFY THAT THIS PLAN WAS PREPARED BY ME OR UNDER MY DIRECT SUPERVISION AND THAT I AM A DULY LICENSED PROFESSIONAL ENGINEER UNDER THE LAWS OF THE STATE OF MINNESOTA.
 PRINT NAME: MARK R. STATZ
 SIGNATURE: *Mark R. Statz*
 DATE: 7/14/14 LICENSE NO. 42717

DRAWN BY: JWJ DATE: 03/24/2014
 DESIGN BY: PE DATE: 03/24/2014
 CHECKED BY: MRS DATE: 03/24/2014

CITY OF
CENTERVILLE
 Established 1857

S.A.P. 002-621-010

GRADING & EROSION CONTROL
 STA 200+00 TO 205+00
 Sheet 79 of 147 Sheets

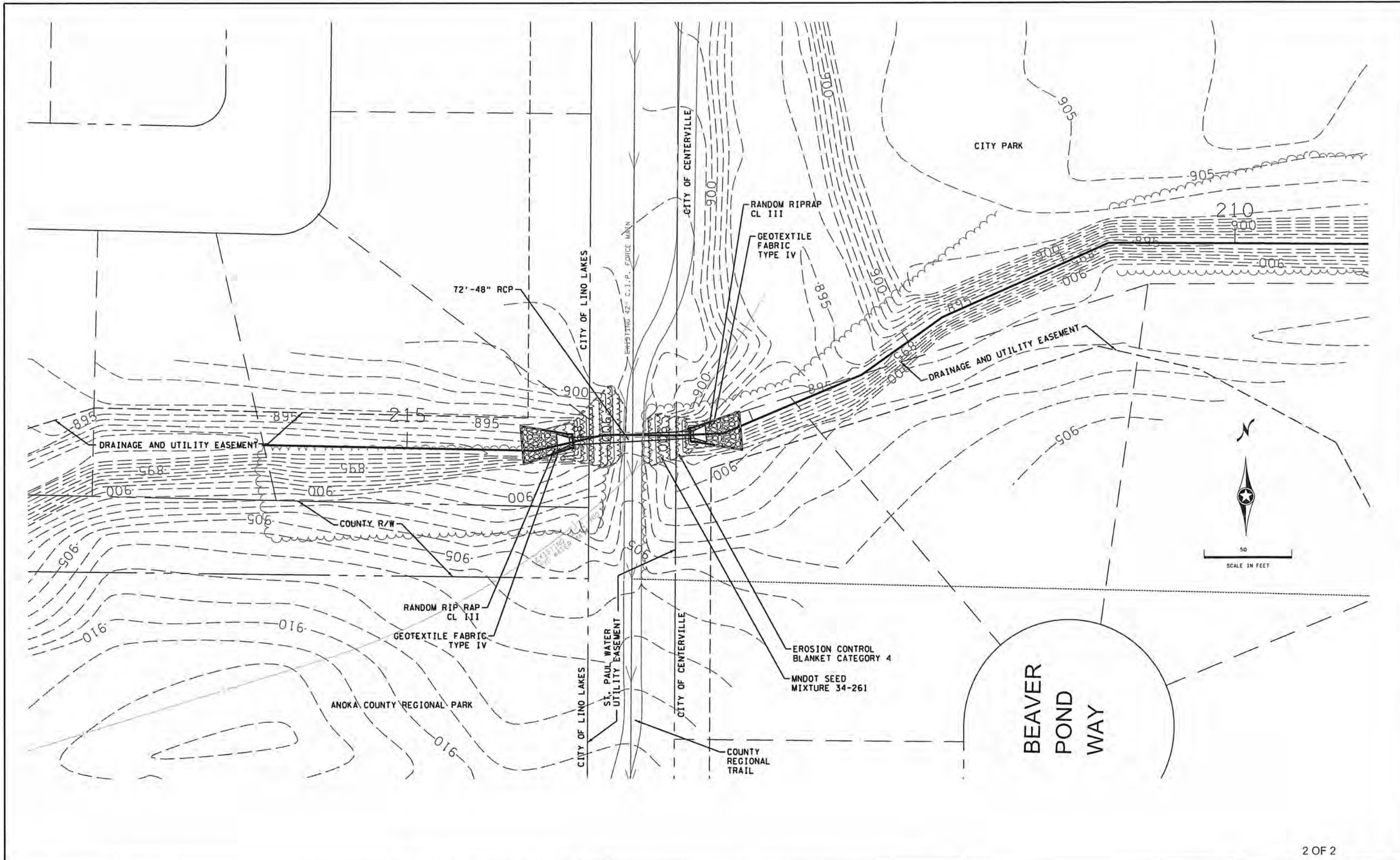

NO	DATE	BY	CKD	APPR	REVISION

NAME: \\us1291-01\workgroup\193801639\CAD\DWG\PLAN SHTS\0262110_EC2.dgn 7/8/2014 1:04:59 PM

I HEREBY CERTIFY THAT THIS PLAN WAS PREPARED BY ME OR UNDER MY DIRECT SUPERVISION AND THAT I AM A DULY LICENSED PROFESSIONAL ENGINEER UNDER THE LAWS OF THE STATE OF MINNESOTA.

PRINT NAME: MARK R. STATZ

SIGNATURE: *[Signature]*

DATE: 7/14/14 LICENSE NO. 42717

DRAWN BY: JWL DATE: 03/24/2014

DESIGN BY: PE DATE: 03/24/2014

CHECKED BY: MRS DATE: 03/24/2014

CITY OF CENTERVILLE

S.A.P. 002-621-010

GRADING & EROSION CONTROL

STA 200+00 TO 205+00

Sheet 80 of 147 Sheets

DISTRICT * : \$DISTRICT@
 IPLOT NAME: \$\$\$PLOT\$NAME\$\$\$
 PATH & FILENAME: \\us1291-f01\workgroup\9338\active\933801639\CAD\DWG\PLAN_SHTS\026210_xp2.dgn

PLOTTED/REVISED: 7/8/2014

EXCAVATION
CU. YD.

EMBANKMENT
CU. YD.

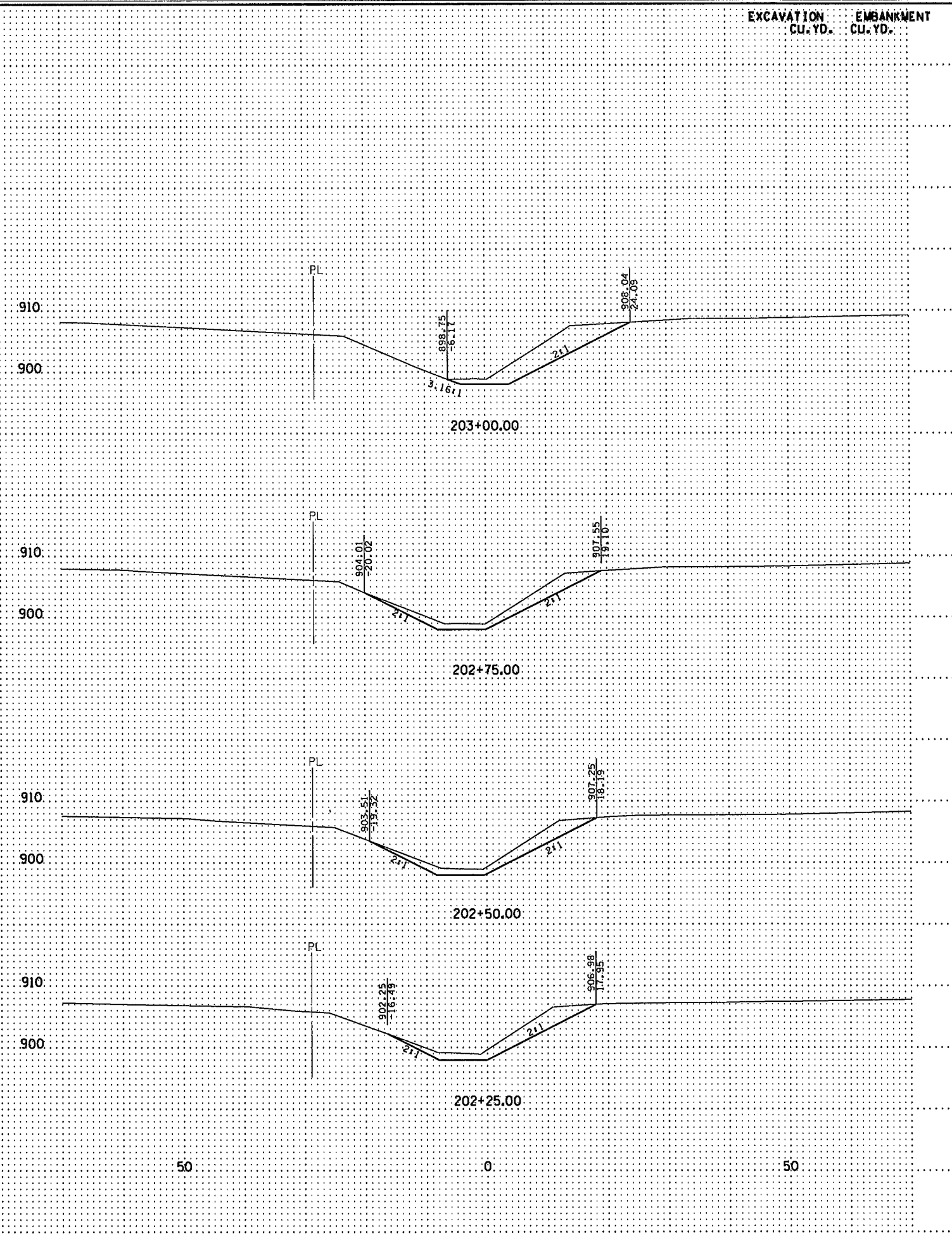
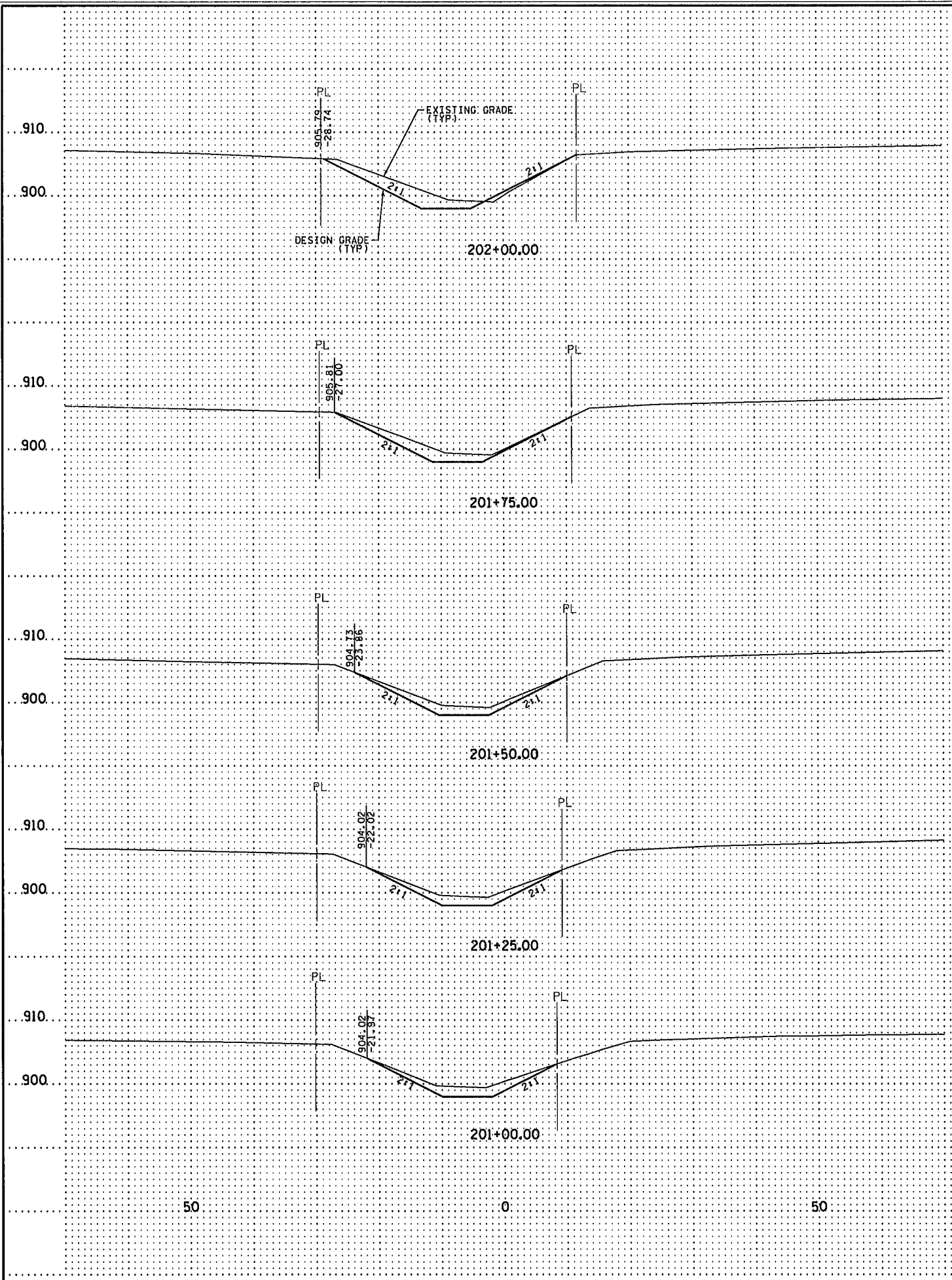

STA. 201+00.00 - 203+00.00

EXCAVATION CU. YD. EMBANKMENT CU. YD.

DISTRICT * : @@DISTRICT@
IPLOT NAME: \$\$\$IPLLOT\$NAME@\$\$
PATH & FILENAME: \\usi291-f01\workgroup\9338\active\9338\CAD\DWG\PLAN_SHT\5026210_xp2.dgn

PLOTTED/REVISED: 7/8/2014

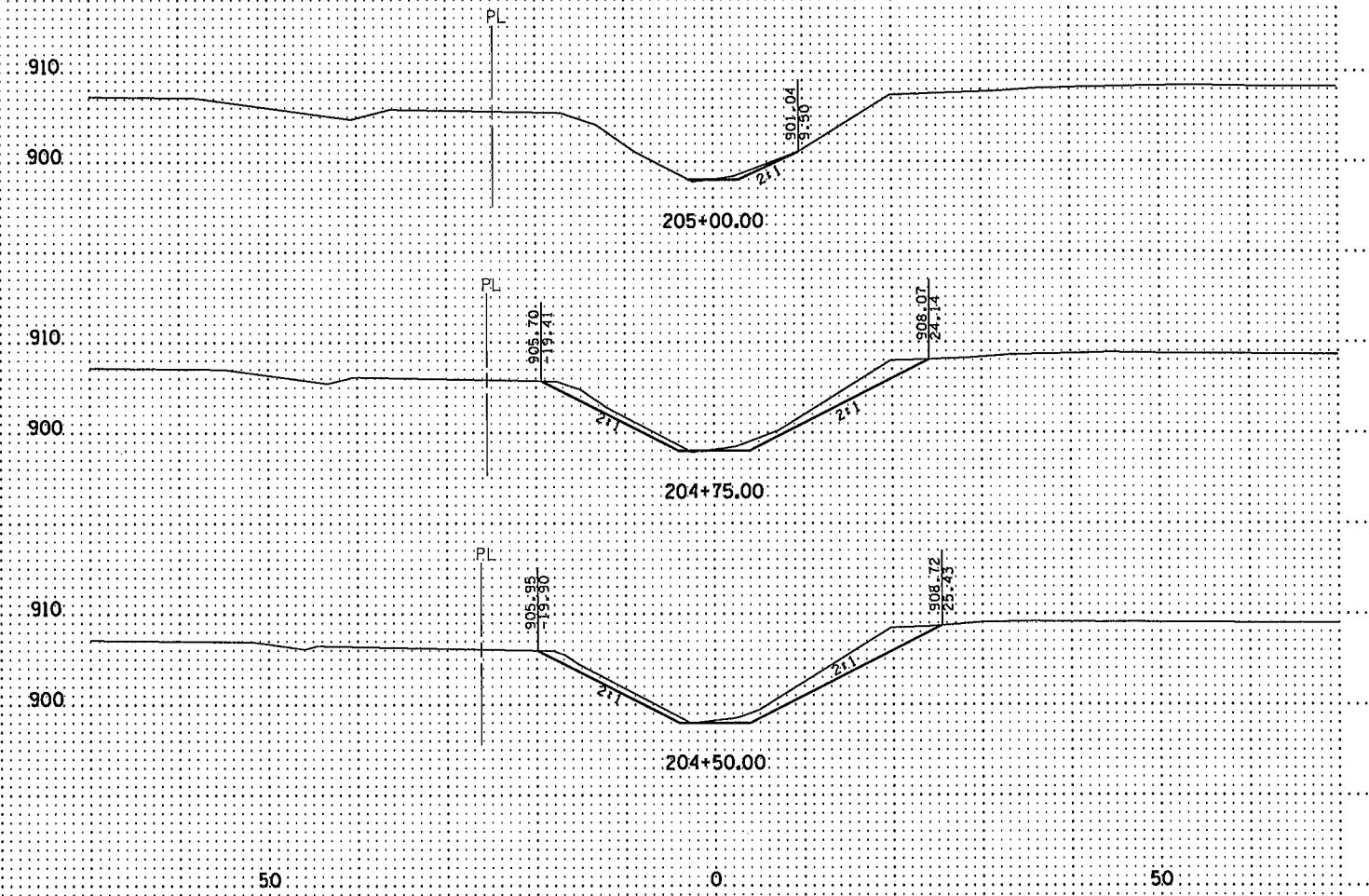
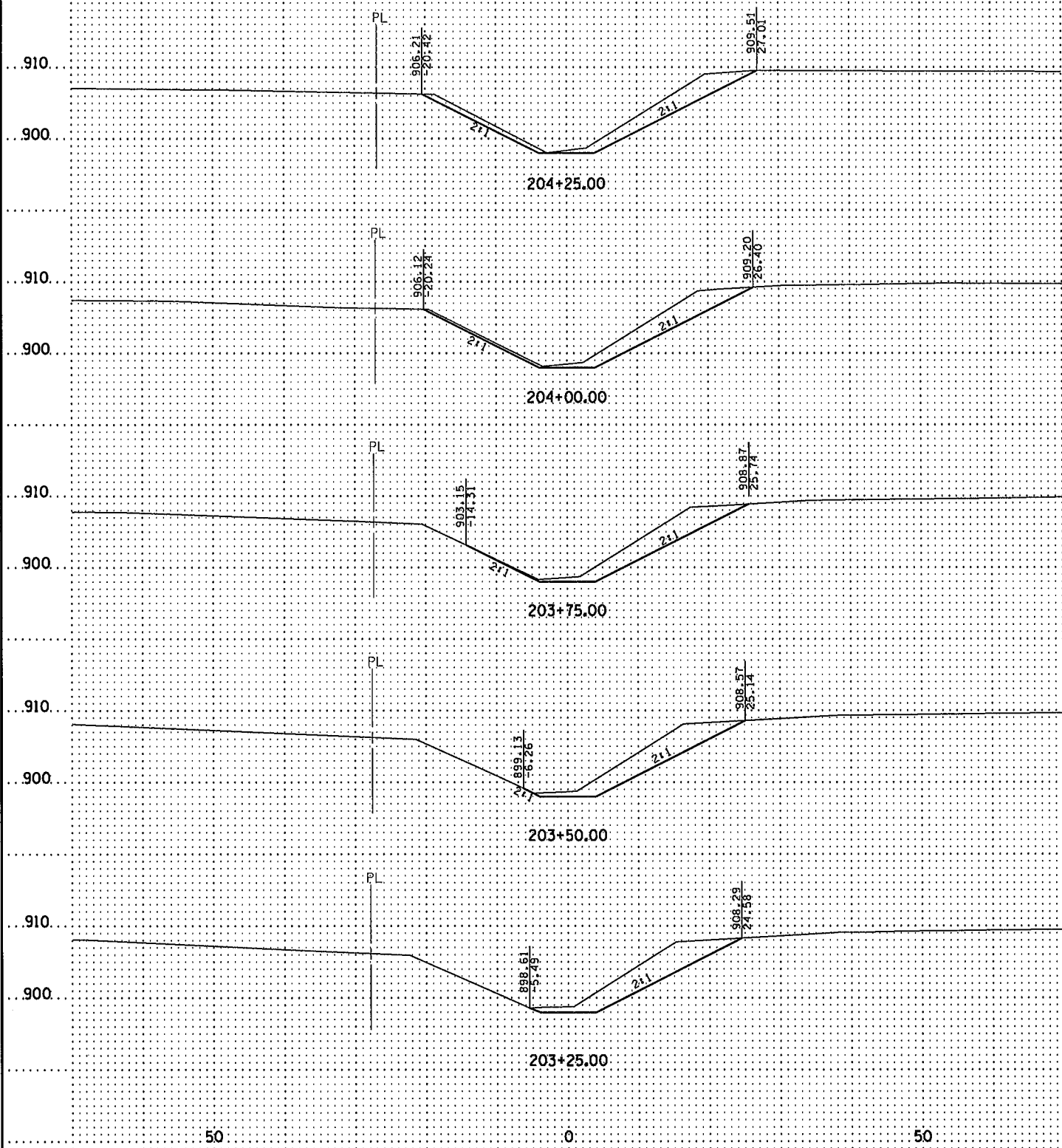

50

0

50

50

0

50

STA. 203+25.00 - 205+00.00

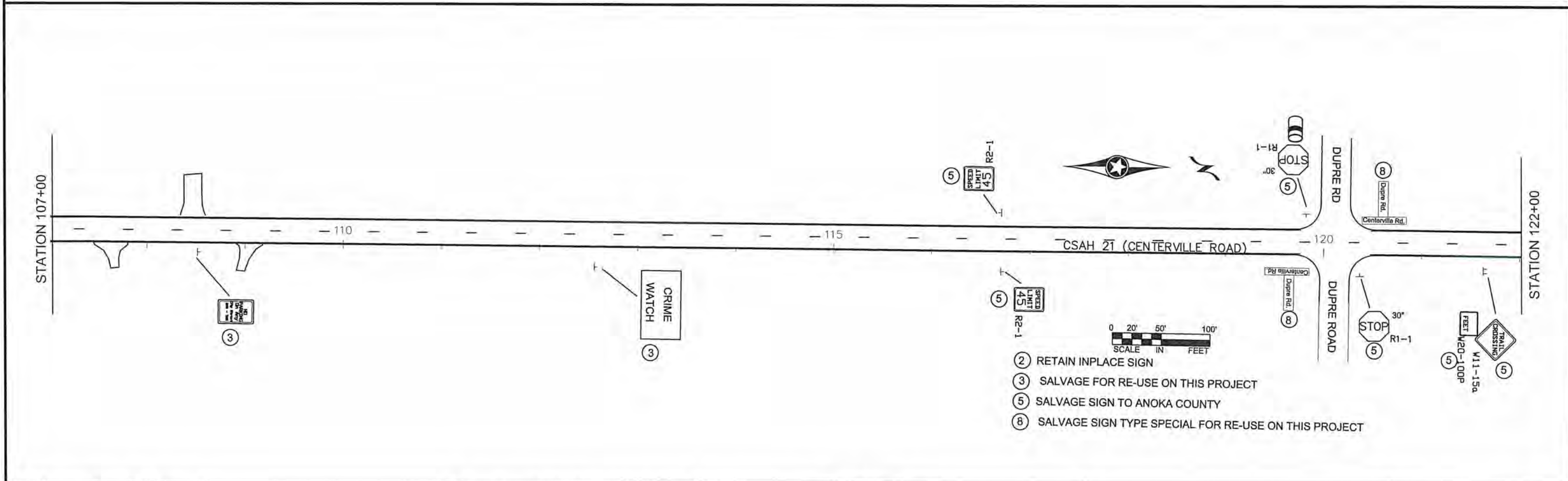
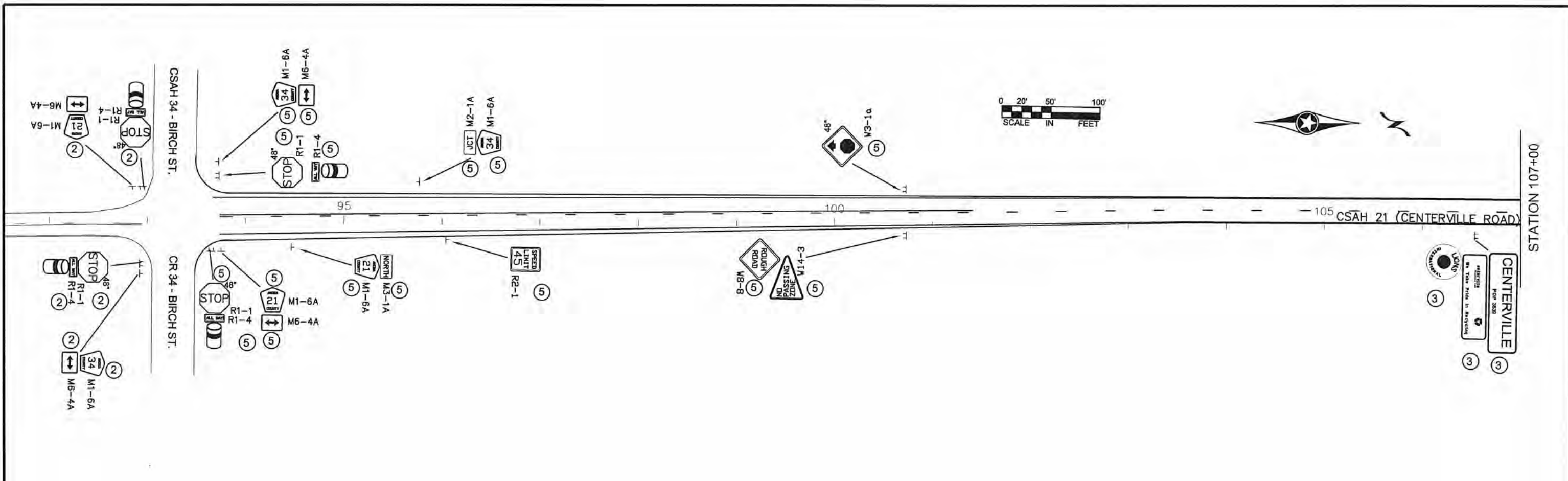

- (2) RETAIN INPLACE SIGN
- (3) SALVAGE FOR RE-USE ON THIS PROJECT
- (5) SALVAGE SIGN TO ANOKA COUNTY
- (8) SALVAGE SIGN TYPE SPECIAL FOR RE-USE ON THIS PROJECT

NO	DATE	BY	CKD	APPR	REVISION

I HEREBY CERTIFY THAT THIS PLAN WAS PREPARED BY ME OR UNDER MY DIRECT SUPERVISION AND THAT I AM A DULY REGISTERED PROFESSIONAL ENGINEER UNDER THE LAWS OF THE STATE OF MINNESOTA.

PRINT NAME: CURT KOBILARCSIK
 SIGNATURE: *Curt Kobilarsik*
 DATE: 7-14-14 REG. NO. 24756

DRAWN BY: RLB DATE 4/17/14
 DESIGN BY: RLB DATE 4/17/14
 CHECKED BY: JR DATE 4/17/14

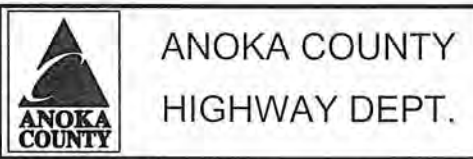

ANOKA COUNTY
 HIGHWAY DEPT.

S.A.P. 002-621-010

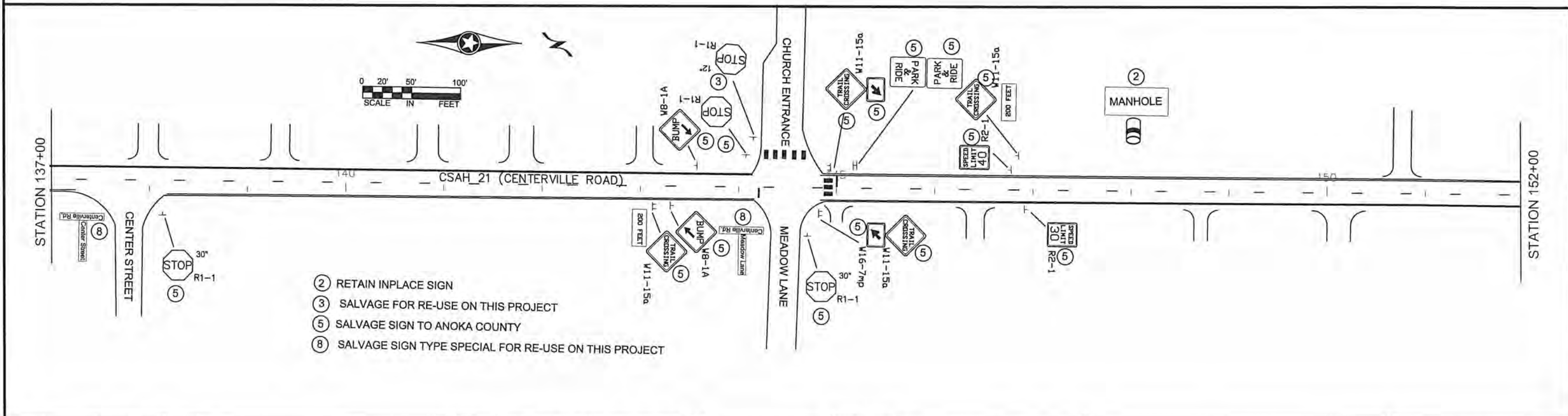
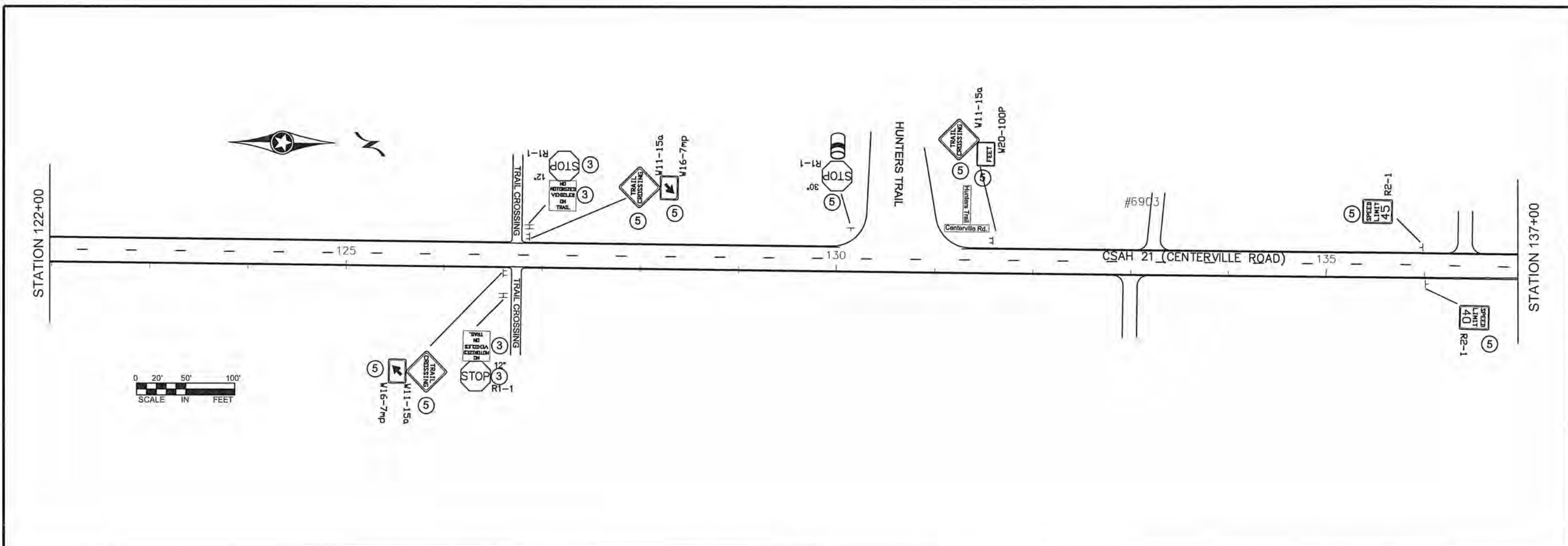

- ② RETAIN INPLACE SIGN
- ③ SALVAGE FOR RE-USE ON THIS PROJECT
- ⑤ SALVAGE SIGN TO ANOKA COUNTY
- ⑧ SALVAGE SIGN TYPE SPECIAL FOR RE-USE ON THIS PROJECT

NO	DATE	BY	CKD	APPR	REVISION

I HEREBY CERTIFY THAT THIS PLAN WAS PREPARED BY ME OR UNDER MY DIRECT SUPERVISION AND THAT I AM A DULY REGISTERED PROFESSIONAL ENGINEER UNDER THE LAWS OF THE STATE OF MINNESOTA.

PRINT NAME: CURT KOBILARCSIK
 SIGNATURE: *[Signature]*
 DATE: 7-14-14 REG. NO. 24756

DRAWN BY: RLB DATE: 4/17/14
 DESIGN BY: RLB DATE: 4/17/14
 CHECKED BY: JR DATE: 4/17/14

ANOKA COUNTY
HIGHWAY DEPT.



S.A.P. 002-621-010

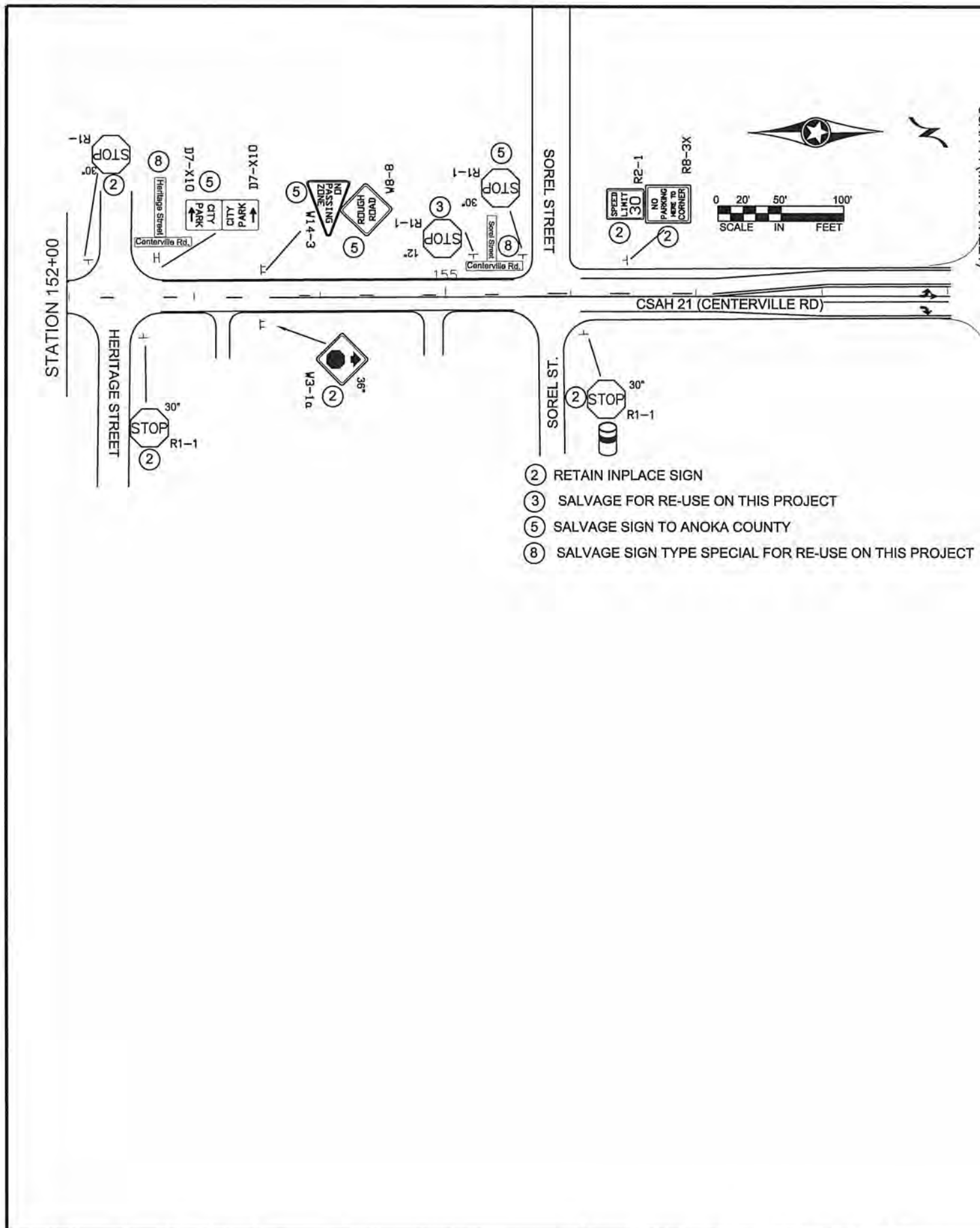

STATION	ADDRESS/DESCRIPTION (NOTES)	SALVAGE SIGN TYPE C	SALVAGE SIGN TYPE D	SALVAGE SIGN TYPE SPECIAL (1)	INSTALL SIGN TYPE C	INSTALL SIGN TYPE D	INSTALL SIGN TYPE SPECIAL (1)	SIGN NUMBER	SIGN LEGEND
		EACH	EACH	EACH	EACH	EACH	EACH		
93+75	Lt	1						R1-1	Stop
93+75	Lt							R1-4	All Way
93+75	Lt	1						M1-6A	34
93+75	Lt							M6-4A	Double Arrow
94+50	Rt	1						M3-1A	NORTH
94+50	Rt							M1-6A	21
95+75	Lt	1						M2-1A	Jct
95+75	Lt							M2-1A	34
96+00	Rt	1						R2-1	45 MPH
100+08	Rt	1						W-14-3	No Passing
100+08	Rt							W-8-B	Rough Road
100+08	Lt	1						W3-1a	Stop Ahead
106+60	Rt	1	1			1		12-3A	Centerville
106+60	Rt								Recycling
106+60	Rt								Lions
108+50	Rt		1			1			No Parking (City)
112+60	Rt		1			1			Crime Watch
116+75	Rt	1						R2-1	45 MPH
116+75	Lt	1						R2-1	45 MPH
119+75	Rt			1			1	Street Sign	Dupre Road
119+75	Lt	1						R1-1	Stop Sign
120+40	Rt	1						R1-1	Stop Sign
120+40	Lt			1			1	Street Sign	Dupre Road
122+00	Rt	1						W11-X7	Trail Crossing
122+00	Rt								500 Feet
126+60	Rt	1						W11-X7	Trail Crossing
126+60	Rt							W16-7mp	Arrow
126+60	Rt								No Motorized Vehicles On Trail
126+60	Rt	1			1			R1-1	Stop - 12"
126+80	Lt	1						W11-X7	Trail Crossing
126+80	Lt							W16-7mp	Arrow
126+80	Lt								No Motorized Vehicles On Trail
126+80	Lt	1			1			R1-1	Stop - 12"
130+20	Lt	1						R1-1	Stop - 30"
131+00	Lt			1			1	Street Sign	Hunters Trail
131+80	Lt	1						W11-X7	Trail Crossing
131+80	Lt								500 Feet
136+00	Rt	1						R2-1	40 MPH
136+00	Lt	1						R2-1	45 MPH
137+50	Rt			1			1	Street Sign	Center St.
138+10	Rt	1						R1-1	Stop - 30"
143+10	Rt	1						W11-X7	Trail Crossing
143+10	Rt								200 Feet
143+30	Rt	1						W8-1a	Bump
143+60	Lt	1						W8-1a	Bump
144+00	Rt			1			1	Street Sign	Meadow Lane
144+00	Lt	1						R1-1	Stop - 30"
144+00	Lt	1				1		R1-1	Stop - 12"
144+70	Rt	1						R1-1	Stop - 30"
144+80	Lt	1						W11-X7	Trail Crossing
144+80	Lt							W16-7mp	Arrow
144+80	Rt	1						W11-X7	Trail Crossing
144+80	Rt							W16-7mp	Arrow
145+00	Lt		1			1		D4-2R	Park & Ride
145+00	Lt							D4-2R	Park & Ride
146+80	Lt	1						R2-1	40 MPH
146+80	Lt	1						W11-X7	Trail Crossing
146+80	Lt								200 Feet
147+00	Rt	1						R2-1	30 MPH
152+00	Lt	1						R1-1	Stop - 30"
152+50	Rt			1			1	Street Sign	Heritage Street
152+50	Lt		1			1		D7-X10	CITY PARK
152+50	Rt	1						R1-1	Stop - 30"
153+50	Lt	1						W-14-3	No Passing
153+50	Lt							W-8-B	Rough Road
155+40	Lt	1			1			R1-1	Stop-12"
155+50	Lt			1			1	Street Sign	Sorel St.
155+60	Lt	1						R1-1	Stop-30"
Total		38	5	7	4	5	7		

CONSTRUCTION NOTES:
 1. SIGN TYPE SPECIAL ARE TO REMAIN VISIBLE AT ALL TIMES. SHALL BE PAID BY THE EACH, WHEN RELOCATION IS REQUIRED.

NO	DATE	BY	CKD	APPR	REVISION

I HEREBY CERTIFY THAT THIS PLAN WAS PREPARED BY ME OR UNDER MY DIRECT SUPERVISION AND THAT I AM A DULY REGISTERED PROFESSIONAL ENGINEER UNDER THE LAWS OF THE STATE OF MINNESOTA.
 PRINT NAME: CURT KOBIARCSIK
 SIGNATURE: *Curt Kobilarcsik*
 DATE: 7-14-14 REG. NO. 24756

DRAWN BY: RLB DATE: 4/17/14
 DESIGN BY: RLB DATE: 4/17/14
 CHECKED BY: JR DATE: 4/17/14

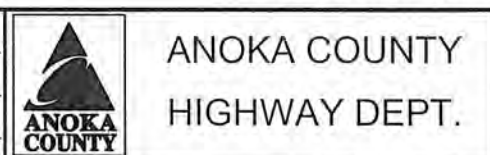

S.A.P. 002-621-010

F&I 7 DAYS IN ADVANCE OF CLOSURE

BEGINS MO/DAY
G20-X2

ROAD CLOSED
DUPREE RD
TO
BIRCH ST.
FOLLOW DETOUR

BEGINS MO/DAY
G20-X2
F&I 7 DAYS IN ADVANCE OF CLOSURE

ROAD CLOSED
BIRCH ST.
TO
DUPREE RD
FOLLOW DETOUR

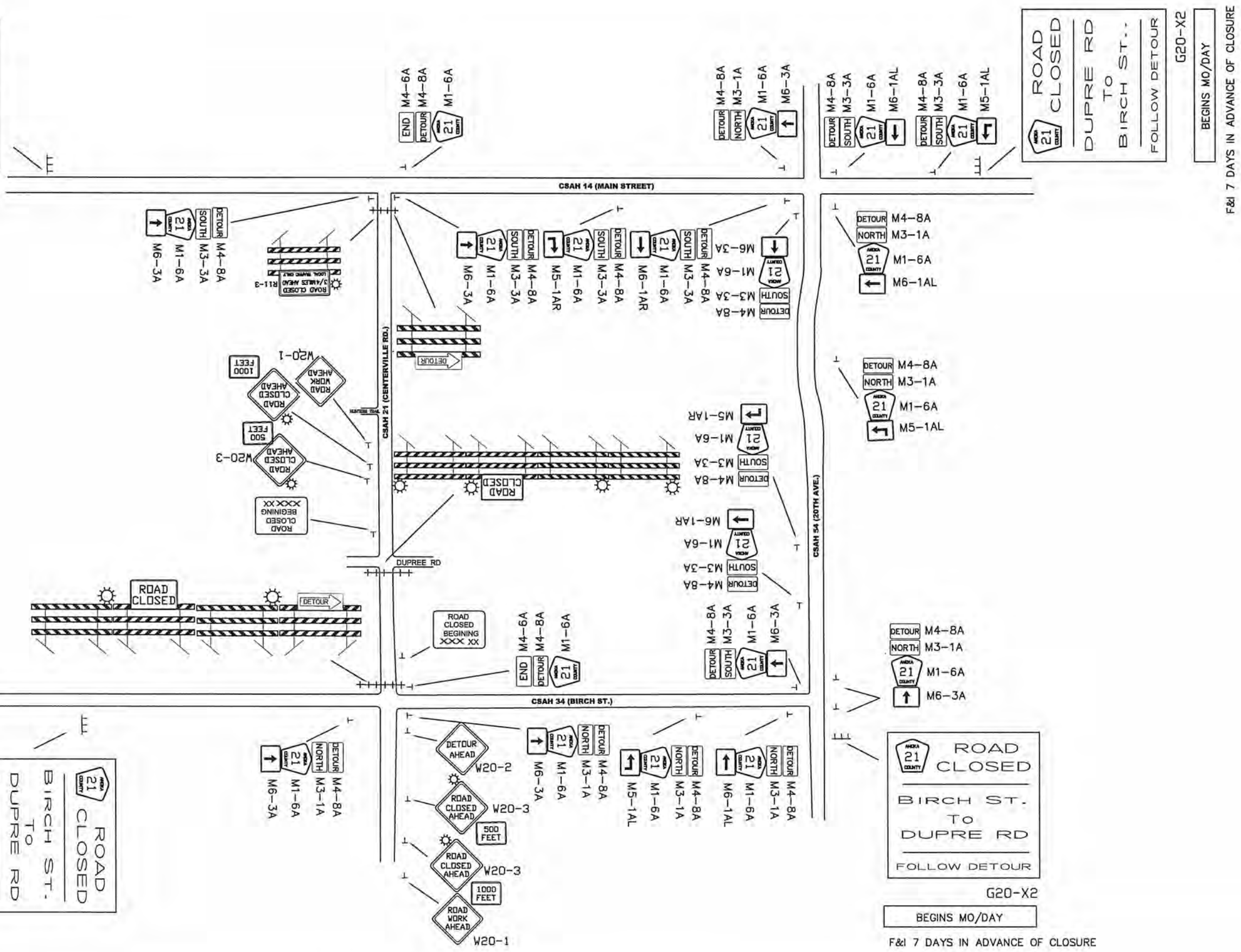

BEGINS MO/DAY
G20-X2

F&I 7 DAYS IN ADVANCE OF CLOSURE

NO	DATE	BY	CKD	APPR	REVISION
NAME: T:\Traffic\dwg\CSAH 21 (Centerville Rd)\Detour for culvert replacement.dwg					

I HEREBY CERTIFY THAT THIS PLAN WAS PREPARED BY ME OR UNDER MY DIRECT SUPERVISION AND THAT I AM A DULY REGISTERED PROFESSIONAL ENGINEER UNDER THE LAWS OF THE STATE OF MINNESOTA.

PRINT NAME: CURT KOBILARCSIK
SIGNATURE: *Curt Kobilarsik*
DATE: 7-14-14 REG. NO. 24756

DRAWN BY: JS DATE: 4/17/14
DESIGN BY: JS DATE: 4/17/14
CHECKED BY: JR DATE: 4/17/14



ANOKA COUNTY
HIGHWAY DEPT.

S.A.P. 002-621-010

STAGE 1
DETOUR PLAN
Sheet 86 of 147 Sheets

M. U. T. C. D. CODE	SIZE	INSERT	QUANTITY	M. U. T. C. D. CODE	SIZE	INSERT	QUANTITY
W20-1	48' x 48'		• 2	TYPE III	8 FOOT		• 2
W20-2	48' x 48'		• 1	TYPE III	8 FOOT		• 3
W20-3	48' x 48'		• 4	G20-X2	132' x 108'		• 2
W20-100P	24' x 18'		• 2				
W20-100P	24' x 18'		• 2				
M4-10R	48' x 18'		SEE NOTE ②	G20-X2	132' x 108'		• 2
TYPE III	8 FOOT		• 1				
M4-10L	48' x 18'		SEE NOTE ②				
TYPE III	8 FOOT		• 1				
R11-2	48' x 30'		SEE NOTE ②	M4-8A	24' x 12'		• 2
TYPE III	8 FOOT		• 2	M3-4A	24' x 12'		• 2
				M1-6A	24' x 24'		• 1
					21' x 15'		• 1
							• 4
							• 4
R11-3	48' x 30'		SEE NOTE ②	M4-8A	24' x 12'		• 0
TYPE III	8 FOOT		• 1	M3-2A	24' x 12'		• 0
				M1-6A	24' x 24'		• 2
					21' x 15'		• 2
							• 4
							• 4
M4-6A	24' x 12'		• 2				
M4-8A	24' x 12'		• 2				
M1-6A	24' x 24'		• 2				
G20-X1	60' x 48'		• 2				

* SIGN TO BE INSTALLED A MINIMUM OF SEVEN DAYS PRIOR TO ACTUAL CLOSING DATE OF ROAD CLOSURE AND IMPLEMENTATION OF DETOUR SIGING. SIGNS TO BE REMOVED AT TIME OF DETOUR INSTALLATION.

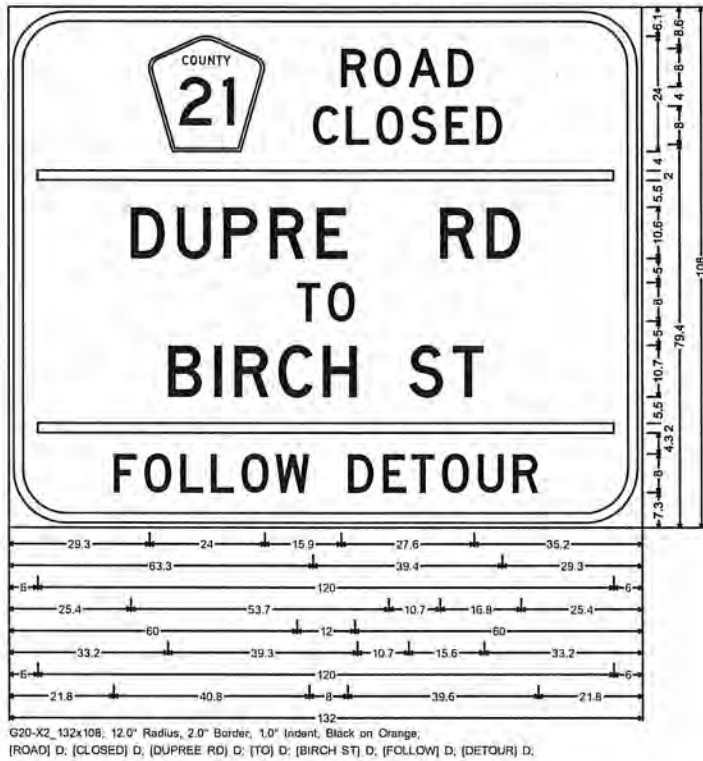

INSTALL G20-X2 SIGNS 7 DAYS PRIOR WITH 'BEGIN/DATE' PLATE; REMOVE AT START DATE OF CONSTRUCTION SO SI READS 'FOLLOW DETOUR'.

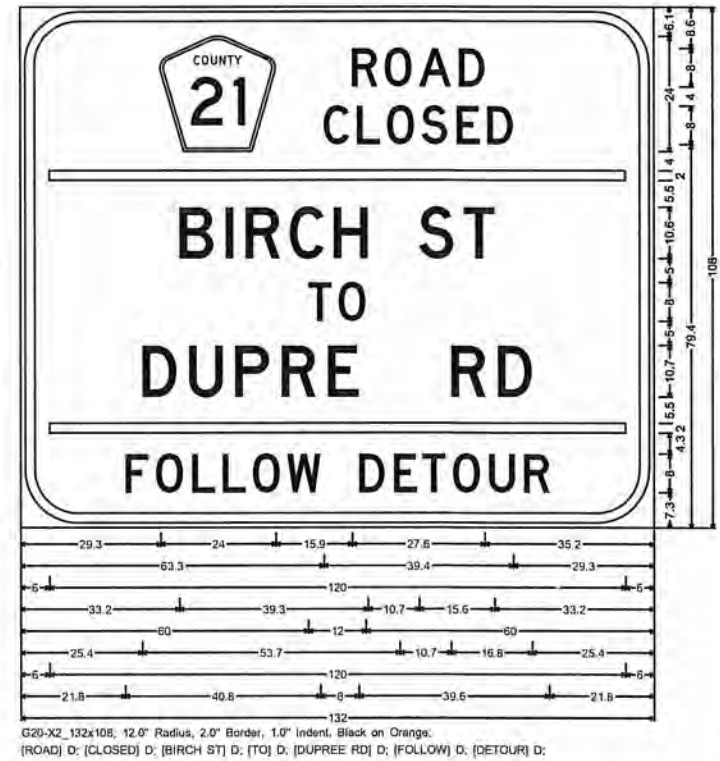

INSTALL G20-X2 SIGNS 7 DAYS PRIOR WITH 'BEGIN/DATE' PLATE; REMOVE AT START DATE OF CONSTRUCTION SO SI READS 'FOLLOW DETOUR'.

- NOTES:
- 1) ALL BARRICADES SHALL BE PROPERLY WEIGHTED WITH SANDBAGS.
 - 2) ALL BARRICADES SHALL HAVE REFLECTIVE MATERIAL ON BOTH SIDES.
 - 3) ALL BARRICADE MARKINGS SHALL BE SLANTED IN ACCORDANCE WITH THE MINNESOTA MANUAL ON UNIFORM TRAFFIC CONTROL DEVICES, INCLUDING THE FIELD MANUAL DATED JANUARY, 1998
 - 4) ALL TRAFFIC CONTROL DEVICES SHALL CONFORM TO THE MOST RECENT EDITION OF THE MINNESOTA MANUAL ON UNIFORM TRAFFIC CONTROL DEVICES, INCLUDING THE FIELD MANUAL DATED JANUARY, 1998
 - 5) ADDITIONS OR CHANGES TO THIS PLAN MAY BE MADE AS DETERMINED BY THE ENGINEER.

F&I 7 DAYS IN ADVANCE OF CLOSURE

ROAD CLOSED
 MAIN ST
 TO
 DUPRE RD
 FOLLOW DETOUR
 G20-X2
 BEGINS MO/DAY

F&I 7 DAYS IN ADVANCE OF CLOSURE

ROAD CLOSED
 DUPRE RD
 TO
 MAIN ST
 FOLLOW DETOUR
 G20-X2
 BEGINS MO/DAY

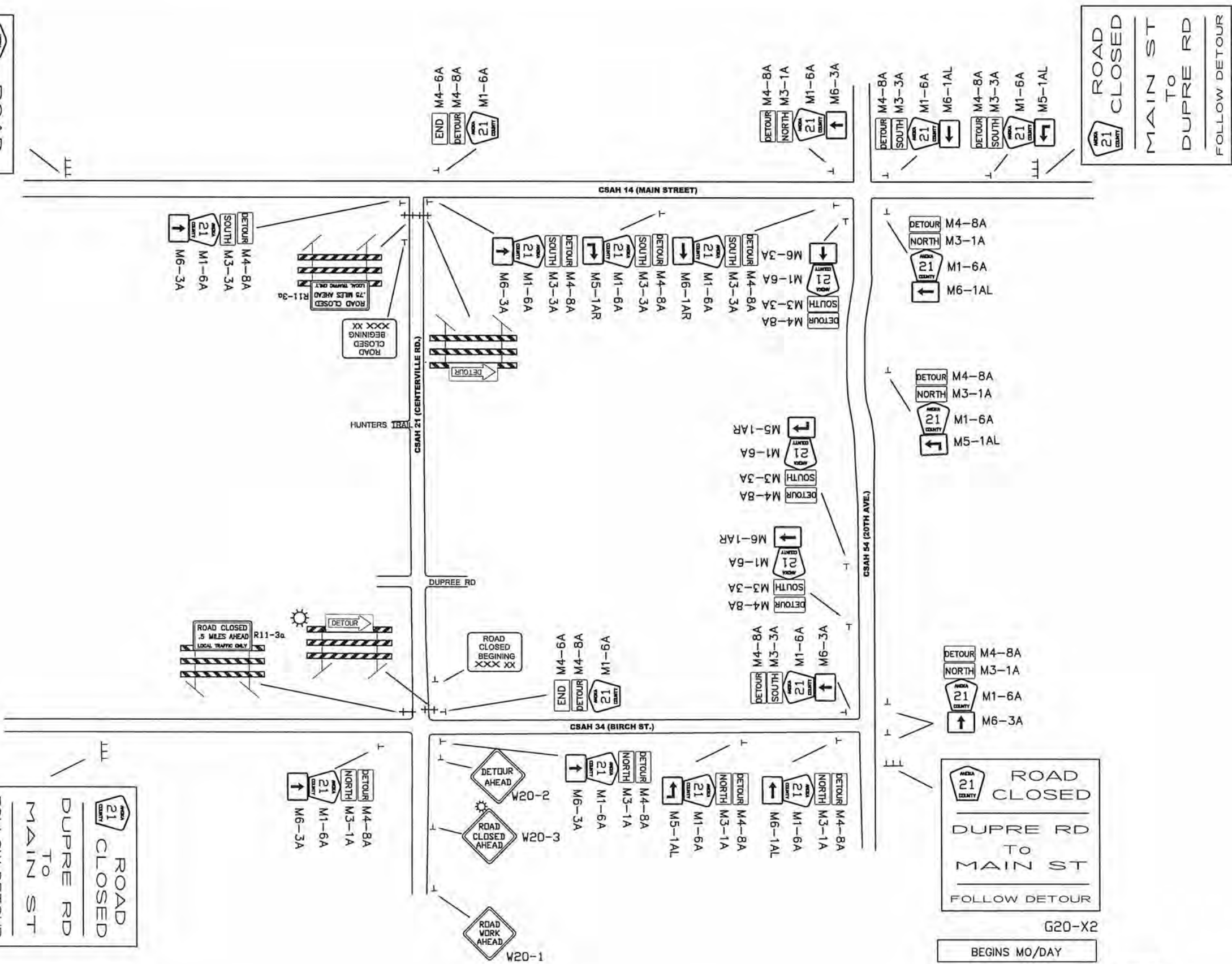

G20-X2

BEGINS MO/DAY

F&I 7 DAYS IN ADVANCE OF CLOSURE

G20-X2
 BEGINS MO/DAY

F&I 7 DAYS IN ADVANCE OF CLOSURE

NO	DATE	BY	CKD	APPR	REVISION

NAME: T:\Traffic\dwg\CSAH 21 (Centerville Rd)\Detour for culvert replacement.dwg

I HEREBY CERTIFY THAT THIS PLAN WAS PREPARED BY ME OR UNDER MY DIRECT SUPERVISION AND THAT I AM A DULY REGISTERED PROFESSIONAL ENGINEER UNDER THE LAWS OF THE STATE OF MINNESOTA.
 PRINT NAME: CURT KOBILARCSIK
 SIGNATURE: *Curt Kobilarsik*
 DATE: 7-14-14 REG. NO. 24756

DRAWN BY JS DATE 4/17/14
 DESIGN BY JS DATE 4/17/14
 CHECKED BY JR DATE 4/17/14



ANOKA COUNTY
 HIGHWAY DEPT.

S.A.P. 002-621-010

STAGE 2
 DETOUR PLAN
 Sheet 88 of 147 Sheets

M. U. T. C. D. CODE	SIZE	INSERT	QUANTITY	M. U. T. C. D. CODE	SIZE	INSERT	QUANTITY
W20-1	48' x 48'		1	G20-X2	132' x 108'		2
W20-2	48' x 48'		1	G20-X2	132' x 108'		2
W20-3	48' x 48'		1				
M4-10R TYPE III	48' x 18' 8 FOOT		SEE NOTE ② 1	M4-8A	24' x 12'		2
M4-10L TYPE III	48' x 18' 8 FOOT		SEE NOTE ② 1	M3-4A	24' x 12'		2
R11-3 TYPE III	48' x 30' 8 FOOT		SEE NOTE ② 1	M1-6A	24' x 24' 21' x 15'		1 1
R11-3 TYPE III	48' x 30' 8 FOOT		SEE NOTE ② 1	M4-8A	24' x 12'		2
				M4-8A	24' x 12'		2
				M1-6A	24' x 24'		2
				G20-X1	60' x 48'		2

INSTALL G20-X2 SIGNS 7 DAYS PRIOR WITH 'BEGIN/DATE' PLATE) REMOVE AT START DATE OF CONSTRUCTION SO SI READS 'FOLLOW DETOUR'.

* SIGN TO BE INSTALLED A MINIMUM OF SEVEN DAYS PRIOR TO ACTUAL CLOSING DATE OF ROAD CLOSURE AND IMPLEMENTATION OF DETOUR SIGING. SIGNS TO BE REMOVED AT TIME OF DETOUR INSTALLATION.

- NOTES:
- 1) ALL BARRICADES SHALL BE PROPERLY WEIGHTED WITH SANDBAGS.
 - 2) ALL BARRICADES SHALL HAVE REFLECTIVE MATERIAL ON BOTH SIDES.
 - 3) ALL BARRICADE MARKINGS SHALL BE SLANTED IN ACCORDANCE WITH THE MINNESOTA MANUAL ON UNIFORM TRAFFIC CONTROL DEVICES, INCLUDING THE FIELD MANUAL DATED JANUARY, 1998
 - 4) ALL TRAFFIC CONTROL DEVICES SHALL CONFORM TO THE MOST RECENT EDITION OF THE MINNESOTA MANUAL ON UNIFORM TRAFFIC CONTROL DEVICES, INCLUDING THE FIELD MANUAL DATED JANUARY, 1998
 - 5) ADDITIONS OR CHANGES TO THIS PLAN MAY BE MADE AS DETERMINED BY THE ENGINEER.



G20-X2, 132x108, 12.0" Radius, 2.0" Border, 1.0" Indent, Black on Orange; [ROAD] D; [CLOSED] D; [MAIN ST] D; [TO] D; [DUPRE RD] D; [FOLLOW] D; [DETOUR] D;

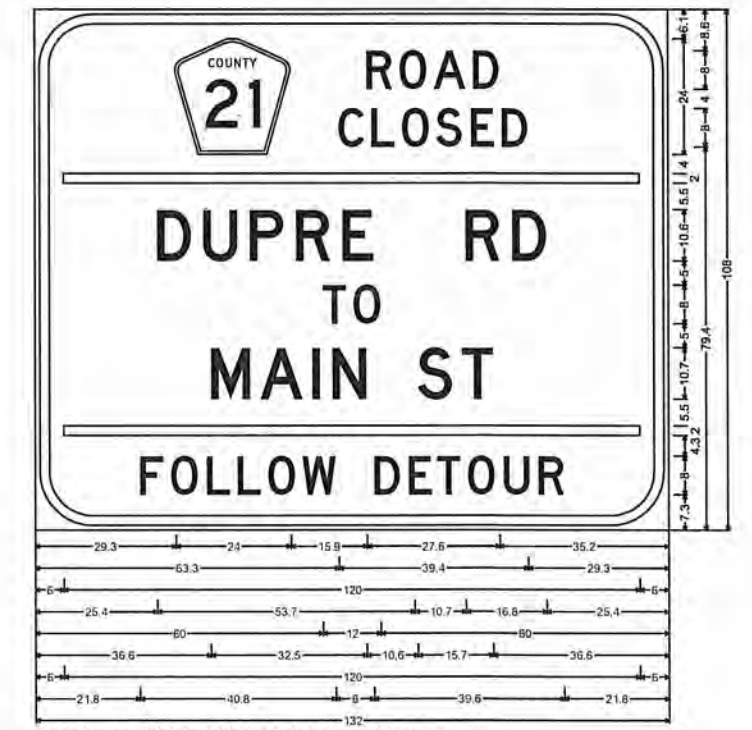

G20-X2, 132x108, 12.0" Radius, 2.0" Border, 1.0" Indent, Black on Orange; [ROAD] D; [CLOSED] D; [DUPRE RD] D; [TO] D; [MAIN ST] D; [FOLLOW] D; [DETOUR] D;

NO	DATE	BY	CHKD	APPR	REVISION

NAME: T:\Traffic\dwg\CSAH 21 (Centerville Rd)\Detour for culvert replacement.dwg

I HEREBY CERTIFY THAT THIS PLAN WAS PREPARED BY ME OR UNDER MY DIRECT SUPERVISION AND THAT I AM A DULY REGISTERED PROFESSIONAL ENGINEER UNDER THE LAWS OF THE STATE OF MINNESOTA.

PRINT NAME: CURT KOBILARCSIK
SIGNATURE:
DATE: 7-17-14 REG. NO. 24756

DRAWN BY: JS DATE: 4/17/14
DESIGN BY: JS DATE: 4/17/14
CHECKED BY: JR DATE: 4/17/14

ANOKA COUNTY
HIGHWAY DEPT.

S.A.P. 002-621-010

STAGE 2
DETOUR QUANTITY
Sheet 89 of 147 Sheets

STAGE 2 CONSTRUCTION NOTES:
 CSAH 21 BETWEEN DUPRE ROAD AND SOREL ST.: FULL RECONSTRUCTION,
 CONSTRUCT CURB & GUTTER, CULVERTS, STORM SEWER SYSTEM, MILL & OVERLAY
 (CONTRACTOR MUST MAINTAIN ACCESS TO LOCAL TRAFFIC).

STAGE 2 TRAFFIC NOTES:
 CSAH 21 CLOSED TO THRU TRAFFIC BETWEEN DUPRE ROAD AND SOREL ST.
 STAGE 2 DETOUR INPLACE. PERMANENT SIGNS AND STRIPING SHALL BE INSTALLED
 BETWEEN CSAH 34 (BIRCH ST) AND DUPRE ROAD.

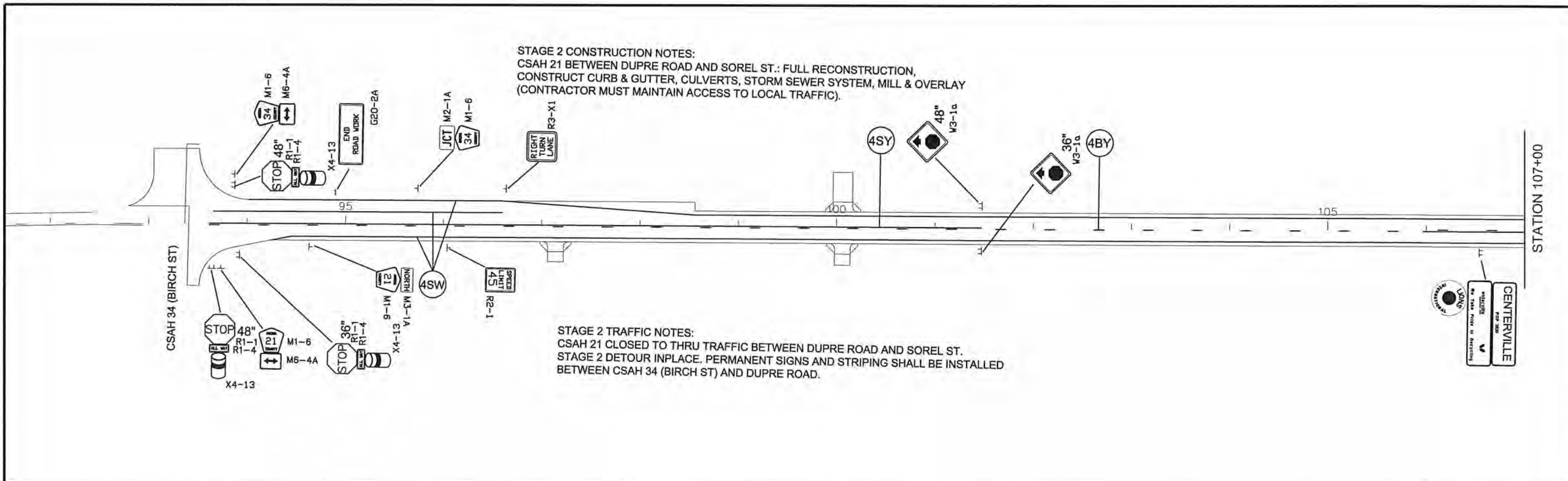

STRIPING KEY

- CIRCLE - EPOXY
- SQUARE - POLY PREFORM
- TRIANGLE - PAINT
- PENTAGON - REMOVABLE PREFORMED PLASTIC MARKING

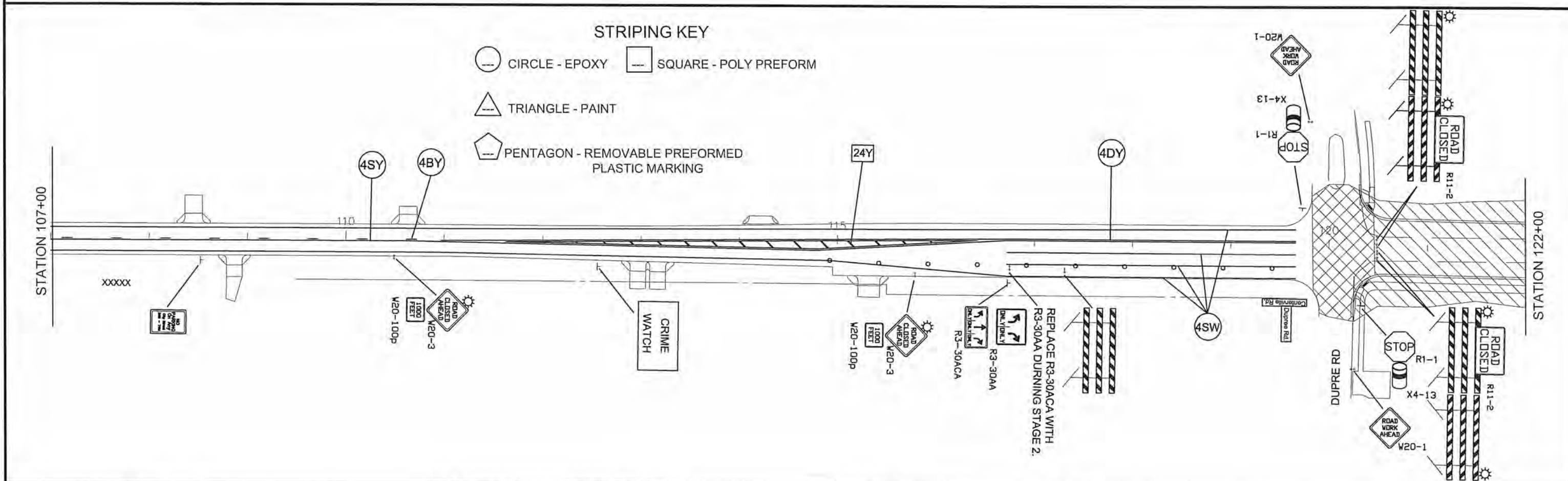

NO	DATE	BY	CKD	APPR	REVISION

I HEREBY CERTIFY THAT THIS PLAN WAS PREPARED BY ME OR UNDER MY DIRECT SUPERVISION AND THAT I AM A DULY REGISTERED PROFESSIONAL ENGINEER UNDER THE LAWS OF THE STATE OF MINNESOTA.
 PRINT NAME: CURT KOBILARCSIK
 SIGNATURE: *Curt Kobilarsik*
 DATE: 7-14-14 REG. NO. 24756

DRAWN BY: RLB DATE: 4/17/14
 DESIGN BY: RLB DATE: 4/17/14
 CHECKED BY: JR DATE: 4/17/14



ANOKA COUNTY
 HIGHWAY DEPT.

S.A.P. 002-621-010

STAGE 2 TRAFFIC CONTROL PLAN
 Sheet 90 of 147 Sheets

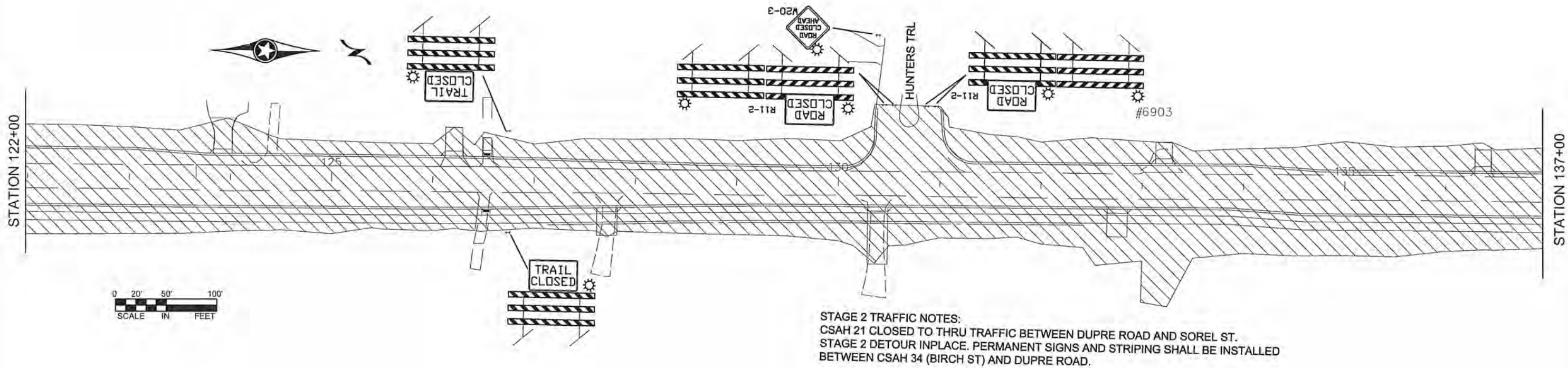

STAGE 2 TRAFFIC NOTES:
 CSAH 21 CLOSED TO THRU TRAFFIC BETWEEN DUPRE ROAD AND SOREL ST.
 STAGE 2 DETOUR INPLACE. PERMANENT SIGNS AND STRIPING SHALL BE INSTALLED
 BETWEEN CSAH 34 (BIRCH ST) AND DUPRE ROAD.

STAGE 2 CONSTRUCTION NOTES:
 CSAH 21 BETWEEN DUPRE ROAD AND SOREL ST.: FULL RECONSTRUCTION,
 CONSTRUCT CURB & GUTTER, CULVERTS, STORM SEWER SYSTEM, MILL & OVERLAY
 (CONTRACTOR MUST MAINTAIN ACCESS TO LOCAL TRAFFIC).

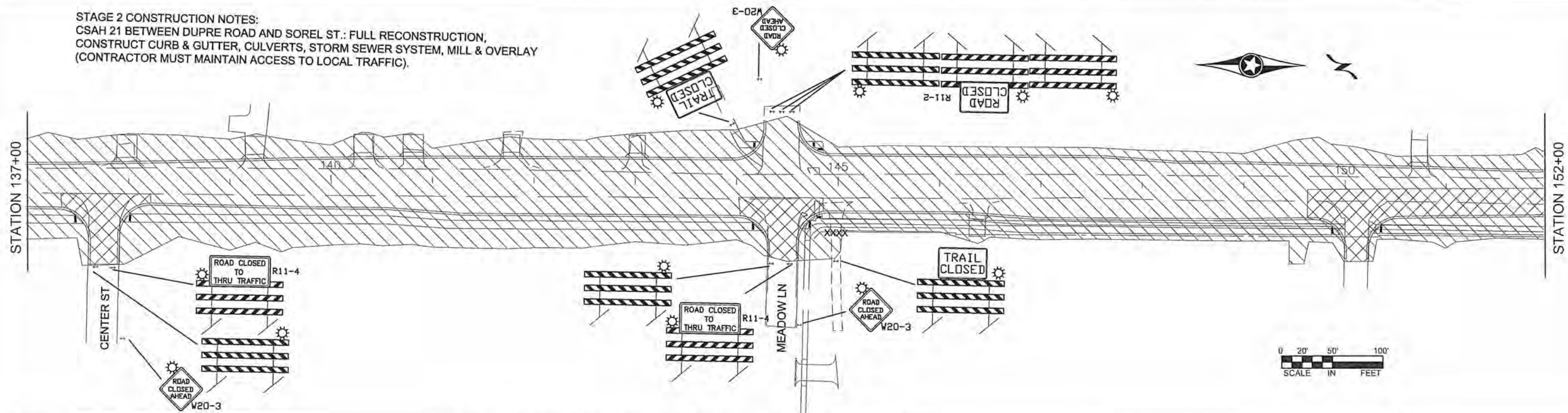

NO	DATE	BY	CKD	APPR	REVISION

I HEREBY CERTIFY THAT THIS PLAN WAS PREPARED BY ME
 OR UNDER MY DIRECT SUPERVISION AND THAT I AM A
 DULY REGISTERED PROFESSIONAL ENGINEER UNDER
 THE LAWS OF THE STATE OF MINNESOTA.
 PRINT NAME: CURT KOBILARCSIK
 SIGNATURE: *Curt Kobilarsik*
 DATE: 7-14-14 REG. NO. 24756

DRAWN BY: RLB DATE: 4/17/14
 DESIGN BY: RLB DATE: 4/17/14
 CHECKED BY: JR DATE: 4/17/14



ANOKA COUNTY
 HIGHWAY DEPT.

S.A.P. 002-621-010

STAGE 2 TRAFFIC
 CONTROL PLAN
 Sheet 91 of 147 Sheets

STAGE 2 CONSTRUCTION NOTES:
 CSAH 21 BETWEEN DUPRE ROAD AND SOREL ST.: FULL RECONSTRUCTION,
 CONSTRUCT CURB & GUTTER, CULVERTS, STORM SEWER SYSTEM, MILL & OVERLAY
 (CONTRACTOR MUST MAINTAIN ACCESS TO LOCAL TRAFFIC).

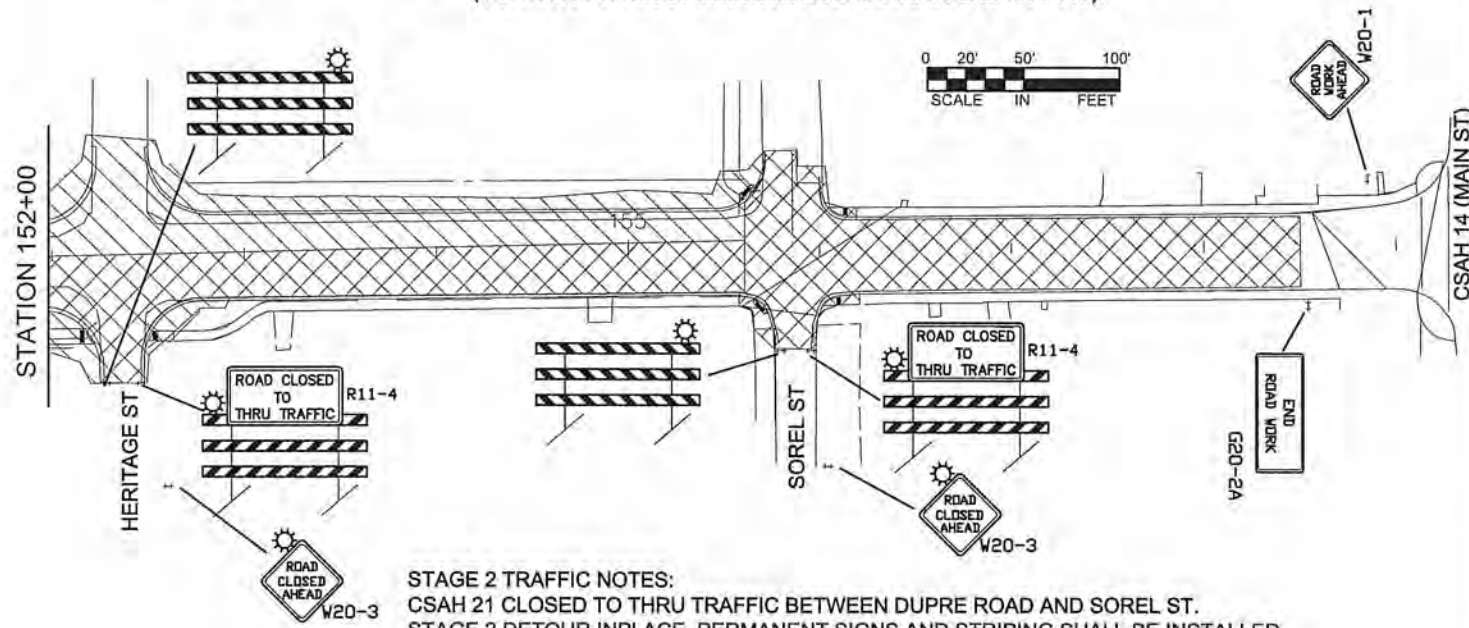

STAGE 2 TRAFFIC NOTES:
 CSAH 21 CLOSED TO THRU TRAFFIC BETWEEN DUPRE ROAD AND SOREL ST.
 STAGE 2 DETOUR INPLACE. PERMANENT SIGNS AND STRIPING SHALL BE INSTALLED
 BETWEEN CSAH 34 (BIRCH ST) AND DUPRE ROAD.

M.U.T.C.D. CODE	SIZE	INSERT	QTY. STG. 2	M.U.T.C.D. CODE	SIZE	INSERT	QTY. STG. 2
FLASHER		TRAIL CLOSED		FLASHER		ROAD CLOSED AHEAD	
R9-9a	24" x 18"		4	W20-1	48" x 48"		8
TYPE III	8 FOOT		4	W20-100p	24" x 18"	XXXX FEET 500	1
				W20-100p	24" x 18"	XXXX FEET 1000	1
FLASHER		ROAD CLOSED		G20-2A	48" X 24"	END ROAD WORK	2
R11-2	48" X 30"		3	W20-1	48" x 48"	ROAD WORK AHEAD	3
TYPE III	8 FOOT		3	W20-1	36" x 30"	ONLY ONLY	3
FLASHER		ROAD CLOSED		REFLECTORIZED REBOUNDBLE DRUM			10
R11-2	48" X 30"		2	FLASHER			
TYPE III	8 FOOT		2	TYPE III	8 FOOT		7
FLASHER		ROAD CLOSED TO THRU TRAFFIC					
R11-4	60" X 30"		4				
TYPE III	8 FOOT		4				
FLASHER							
TYPE III	8 FOOT		4				

NOTES:

- 1) ALL TRAFFIC CONTROL DEVICES SHALL CONFORM TO THE MOST RECENT EDITION OF THE MINNESOTA MANUAL ON UNIFORM TRAFFIC CONTROL DEVICES, INCLUDING THE FIELD MANUAL DATED JANUARY, 2014
- 2) ALL TYPE III BARRICADES SHALL BE REFLECTORIZED ON BOTH SIDES. BARRICADES MARKINGS SHALL BE SLANTED IN ACCORDANCE WITH THE M.U.T.C.D.

NO	DATE	BY	CKD	APPR	REVISION

I HEREBY CERTIFY THAT THIS PLAN WAS PREPARED BY ME OR UNDER MY DIRECT SUPERVISION AND THAT I AM A DULY REGISTERED PROFESSIONAL ENGINEER UNDER THE LAWS OF THE STATE OF MINNESOTA.
 PRINT NAME: CURT KOBILARCSIK
 SIGNATURE:
 DATE: 7-14-14 REG. NO. 24756

DRAWN BY: RLB DATE: 4/17/14
 DESIGN BY: RLB DATE: 4/17/14
 CHECKED BY: JR DATE: 4/17/14



ANOKA COUNTY
 HIGHWAY DEPT.

S.A.P. 002-621-010

STAGE 2 TRAFFIC CONTROL PLAN

**PERMANENT PAVEMENT MARKING PLAN
NOTES AND GUIDELINES**

GENERAL INFORMATION:

THE ENGINEER'S INVOLVEMENT IN THE APPLICATION OF THE MATERIAL SHALL BE LIMITED TO FIELD CONSULTATION AND INSPECTION. ANOKA COUNTY HIGHWAY DEPARTMENT WILL PLACE NECESSARY "SPOTTING" AT APPROPRIATE POINTS TO PROVIDE HORIZONTAL CONTROL FOR STRIPING AND TO DETERMINE NECESSARY STARTING AND CUTOFF POINTS, LONGITUDINAL JOINTS, PAVEMENT EDGES AND EXISTING MARKINGS MAY SERVE AS HORIZONTAL CONTROL WHEN SO DIRECTED.

EDGE LINES AND LANE LINES ARE TO BE BROKEN ONLY AT INTERSECTIONS WITH PUBLIC ROADS AND AT PRIVATE ENTRANCES IF THEY ARE CONTROLLED BY A YIELD SIGN, STOP SIGN OR TRAFFIC SIGNAL. THE BREAK POINT IS TO BE AT THE START OF THE RADIUS FOR THE INTERSECTION OR AT MARKED STOP LINES OR CROSSWALKS.

A TOLERANCE OF 1/4 INCH UNDER OR 1/4 INCH OVER THE SPECIFIED WIDTH WILL BE ALLOWED FOR STRIPING PROVIDED THE VARIATION IS GRADUAL AND DOES NOT DETRACT FROM THE GENERAL APPEARANCE. BROKEN LINE SEGMENTS MAY VARY UP TO ONE-HALF FOOT FROM THE SPECIFIED LENGTHS PROVIDED THE OVER AND UNDER VARIATIONS ARE REASONABLY COMPENSATORY. ALIGNMENT DEVIATIONS FROM THE CONTROL GUIDE SHALL NOT EXCEED 1 INCH. MATERIAL SHALL NOT BE APPLIED OVER LONGITUDINAL JOINTS, ESTABLISHMENT OF APPLICATION TOLERANCES SHALL NOT RELIEVE THE CONTRACTOR OF THEIR RESPONSIBILITY TO COMPLY AS CLOSELY AS PRACTICABLE WITH THE PLANNED DIMENSIONS.

EPOXY:

THE ROAD SURFACE SHALL BE CLEANED AT THE DIRECTION OF THE ENGINEER JUST PRIOR TO APPLICATION. PAVEMENT CLEANING SHALL CONSIST OF AT LEAST BRUSHING WITH A ROTARY BROOM (NON-METALLIC) OR AS RECOMMENDED BY THE MATERIAL MANUFACTURER AND ACCEPTABLE TO THE ENGINEER. NEW PORTLAND CEMENT CONCRETE SURFACES SHALL BE SANDBLAST CLEANED TO REMOVE ANY SURFACE TREATMENT AND/OR LAITANCE ON LOW SPEED (SPEED LIMIT 35 MPH OR LESS) URBAN PORTLAND CEMENT CONCRETE ROADWAYS. SANDBLAST CLEANING SHALL BE USED FOR ALL EPOXY PAVEMENT MARKINGS.

THE EPOXY MARKING APPLICATION SHALL IMMEDIATELY FOLLOW THE PAVEMENT CLEANING. GLASS BEANS SHALL BE APPLIED IMMEDIATELY AFTER APPLICATION OF THE EPOXY RESIN LINE TO PROVIDE AN IMMEDIATE NO-TRACK SYSTEM.

AN EPOXY RESIN LINE 4" WIDE AND 15 MILL THICKNESS (WET), REQUIRES AN APPLICATION RATE OF ONE (1) GALLON OF COMPONENTS FOR 320 FEET OF LINE. GLASS BEADS SHALL BE APPLIED AT A POUND PER GALLON RATE SUFFICIENT TO ACHIEVE AN ACCEPTABLE NO-TRACK SYSTEM.

OPERATIONS SHALL BE CONDUCTED ONLY WHEN THE ROAD PAVEMENT SURFACE TEMPERATURES ARE 50 DEGREES FAHRENHEIT OR GREATER.

PERMANENT PAVEMENT MARKINGS SHALL NOT BE PLACED OVER TEMPORARY TAPE MARKINGS.

PREFORMED THERMOPLASTIC:

THE PREFORMED THERMOPLASTIC MARKINGS SHALL BE APPLIED IN ACCORDANCE WITH THE MANUFACTURER'S RECOMMENDATIONS ON CLEAN AND DRY SURFACES. SEE SPECIAL PROVISIONS FOR PREFORMED THERMOPLASTIC MARKING SPECIFICATIONS.

PAINT:

AT THE TIME OF APPLYING THE MARKING MATERIAL, THE APPLICATION AREA SHALL BE FREE OF CONTAMINATION. THE CONTRACTOR SHALL CLEAN THE ROADWAY SURFACE PRIOR TO THE LINE APPLICATION IN A MANNER AND TO THE EXTENT REQUIRED BY THE ENGINEER.

GLASS BEADS SHALL BE APPLIED IMMEDIATELY AFTER APPLICATION OF THE PAINT LINE.

EXCEPT WHEN USED AS A TEMPORARY MARKING, PAVEMENT MARKINGS SHALL ONLY BE APPLIED IN SEASONABLE WEATHER WHEN AIR TEMPERATURE IS 50 DEGREES FARHENHEIT OR HIGHER AND SHALL NOT BE APPLIED WHEN THE WIND OR OTHER CONDITIONS CAUSE A FILM OR DUST TO BE DEPOSITED ON THE PAVEMENT SURFACE AFTER CLEANING AND BEFORE THE MARKING MATERIAL CAN BE APPLIED.

THE FILLING OF TANKS, POURING OF MATERIALS OR CLEANING OF EQUIPMENT SHALL NOT BE PERFORMED ON UNPROTECTED PAVEMENT SURFACES UNLESS ADEQUATE PROVISIONS ARE MADE TO PREVENT SPILLAGE OF MATERIAL.

PAVEMENT MARKING TABULATION		
ITEM	UNIT	TOTAL QUANTITY
24" YELLOW THERMO- PLASTIC	LIN FT	420
24" WHITE THERMO- PLASTIC	LIN FT	56
3' X 6' THERMO- PLASTIC ZEBRA CROSSWALK	SQ FT	234
4" SOLID LINE WHITE - EPOXY PAINT	LIN FT	15350
4" SOLID LINE YELLOW - EPOXY PAINT	LIN FT	1290
4" BROKEN LINE YELLOW - EPOXY PAINT	LIN FT	350
4" DOUBLE YELLOW -EPOXY PAINT	LIN FT	15340

SYMBOLS & MATERIALS LEGEND

■ CROSSWALK BLOCK WHITE PREFORMED THERMOPLASTIC

← PAVEMENT MESSAGE (LEFT ARROW) PREFORMED THERMOPLASTIC

STRIPING KEY

○ CIRCLE - EPOXY □ SQUARE PREFORMED THERMOPLASTIC

△ TRIANGLE - PAINT

⬠ PENTAGON - REMOVABLE PREFORMED PLASTIC MARKING

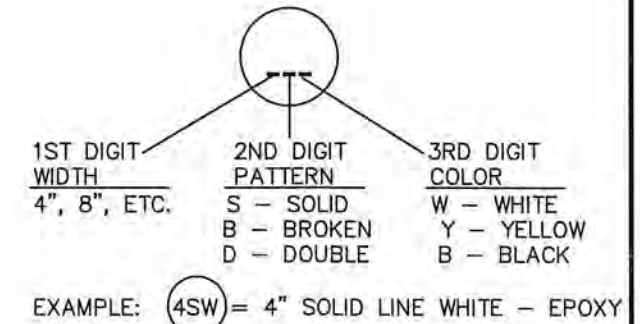

NO	DATE	BY	CKD	APPR	REVISION

NAME: P:\13-01-00\CSAH 18\Bases\TRAFFIC\Perm pvmt mrkg guide notes_guidelines.dwg

I HEREBY CERTIFY THAT THIS PLAN WAS PREPARED BY ME OR UNDER MY DIRECT SUPERVISION AND THAT I AM A DULY LICENSED PROFESSIONAL ENGINEER UNDER THE LAWS OF THE STATE OF MINNESOTA.

PRINT NAME: CURT KOBILARCSIK
 SIGNATURE: *Curt Kobilarsik*
 DATE: 7-14-14 LICENSE NO. 24756

DRAWN BY: RLB DATE: 4/17/14
 DESIGN BY: RLB DATE: 4/17/14
 CHECKED BY: JR DATE: 4/17/14



**ANOKA COUNTY
HIGHWAY DEPT.**

S.A.P. 002-621-010

PERMANENT MARKING TABULATION
 Sheet 93 of 147 Sheets

STRIPING KEY

- CIRCLE - EPOXY
- SQUARE - POLY PREFORM
- TRIANGLE - PAINT
- PENTAGON - REMOVABLE PREFORMED PLASTIC MARKING

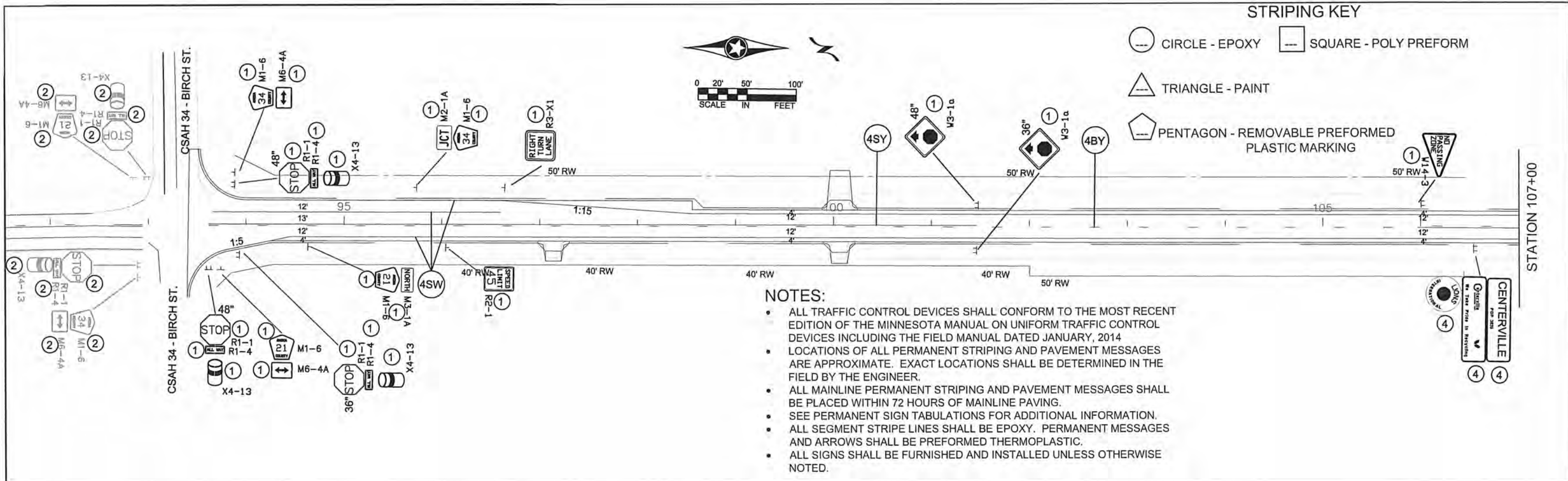
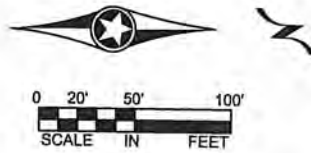

- NOTES:**
- ALL TRAFFIC CONTROL DEVICES SHALL CONFORM TO THE MOST RECENT EDITION OF THE MINNESOTA MANUAL ON UNIFORM TRAFFIC CONTROL DEVICES INCLUDING THE FIELD MANUAL DATED JANUARY, 2014
 - LOCATIONS OF ALL PERMANENT STRIPING AND PAVEMENT MESSAGES ARE APPROXIMATE. EXACT LOCATIONS SHALL BE DETERMINED IN THE FIELD BY THE ENGINEER.
 - ALL MAINLINE PERMANENT STRIPING AND PAVEMENT MESSAGES SHALL BE PLACED WITHIN 72 HOURS OF MAINLINE PAVING.
 - SEE PERMANENT SIGN TABULATIONS FOR ADDITIONAL INFORMATION.
 - ALL SEGMENT STRIPE LINES SHALL BE EPOXY. PERMANENT MESSAGES AND ARROWS SHALL BE PREFORMED THERMOPLASTIC.
 - ALL SIGNS SHALL BE FURNISHED AND INSTALLED UNLESS OTHERWISE NOTED.

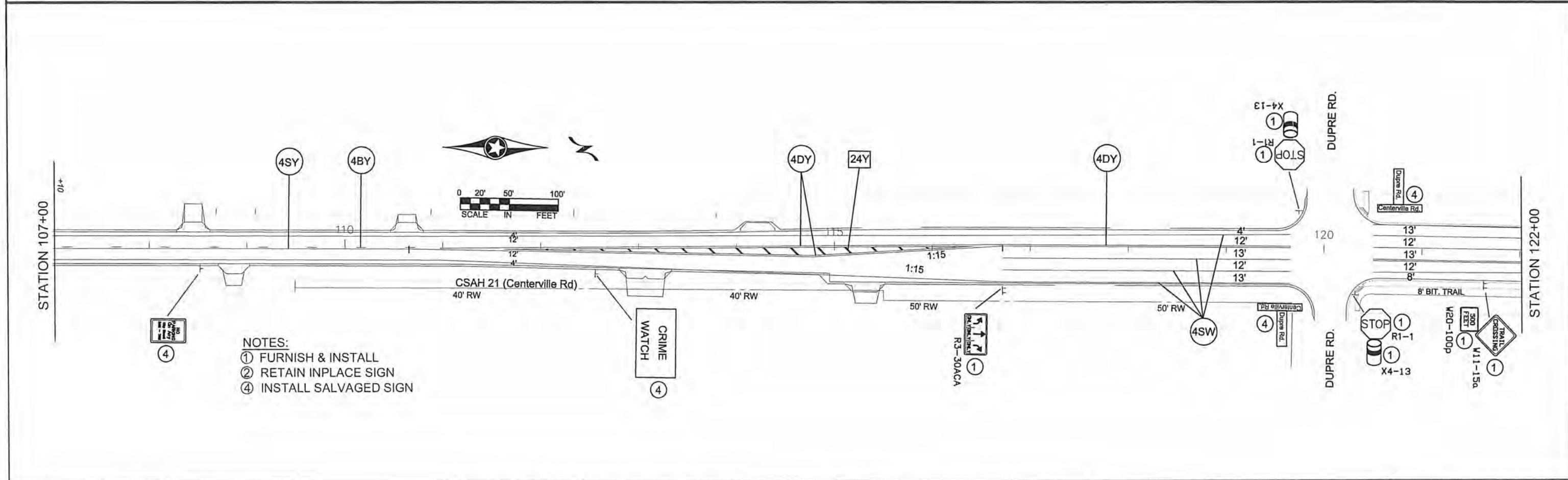

- NOTES:**
- ① FURNISH & INSTALL
 - ② RETAIN INPLACE SIGN
 - ④ INSTALL SALVAGED SIGN

<table border="1" style="width: 100%; border-collapse: collapse;"> <thead> <tr> <th>NO</th> <th>DATE</th> <th>BY</th> <th>CKD</th> <th>APPR</th> <th>REVISION</th> </tr> </thead> <tbody> <tr> <td> </td> <td> </td> <td> </td> <td> </td> <td> </td> <td> </td> </tr> </tbody> </table>	NO	DATE	BY	CKD	APPR	REVISION							<p>I HEREBY CERTIFY THAT THIS PLAN WAS PREPARED BY ME OR UNDER MY DIRECT SUPERVISION AND THAT I AM A DULY REGISTERED PROFESSIONAL ENGINEER UNDER THE LAWS OF THE STATE OF MINNESOTA.</p> <p>PRINT NAME: CURT KOBILARCSIK</p> <p>SIGNATURE: <i>Curt Kobilarsik</i></p> <p>DATE: 7-22-14 REG. NO. 24756</p>	<p>DRAWN BY: RLB DATE: 4/17/14</p> <p>DESIGN BY: RLB DATE: 4/17/14</p> <p>CHECKED BY: JR DATE: 4/17/14</p>	<p>ANOKA COUNTY HIGHWAY DEPT.</p>	<p>S.A.P. 002-621-010</p>	<p>PERMANENT SIGNING & STRIPING PLAN</p> <p>Sheet 94 of 147 Sheets</p>
NO	DATE	BY	CKD	APPR	REVISION												

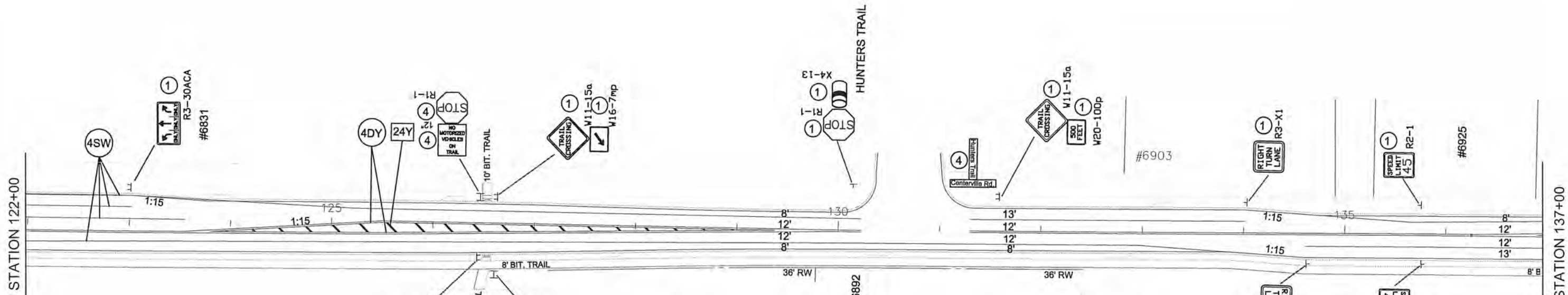

NOTES:

- ALL TRAFFIC CONTROL DEVICES SHALL CONFORM TO THE MOST RECENT EDITION OF THE MINNESOTA MANUAL ON UNIFORM TRAFFIC CONTROL DEVICES INCLUDING THE FIELD MANUAL DATED JANUARY, 2014
- LOCATIONS OF ALL PERMANENT STRIPING AND PAVEMENT MESSAGES ARE APPROXIMATE. EXACT LOCATIONS SHALL BE DETERMINED IN THE FIELD BY THE ENGINEER.
- ALL MAINLINE PERMANENT STRIPING AND PAVEMENT MESSAGES SHALL BE PLACED WITHIN 72 HOURS OF MAINLINE PAVING.
- SEE PERMANENT SIGN TABULATIONS FOR ADDITIONAL INFORMATION.
- ALL SEGMENT STRIPE LINES SHALL BE EPOXY. PERMANENT MESSAGES AND ARROWS SHALL BE PREFORMED THERMOPLASTIC.
- ALL SIGNS SHALL BE FURNISHED AND INSTALLED UNLESS OTHERWISE NOTED.

STRIPING KEY

- CIRCLE - EPOXY
- SQUARE - POLY PREFORM
- △ TRIANGLE - PAINT
- ⬠ PENTAGON - REMOVABLE PREFORMED PLASTIC MARKING

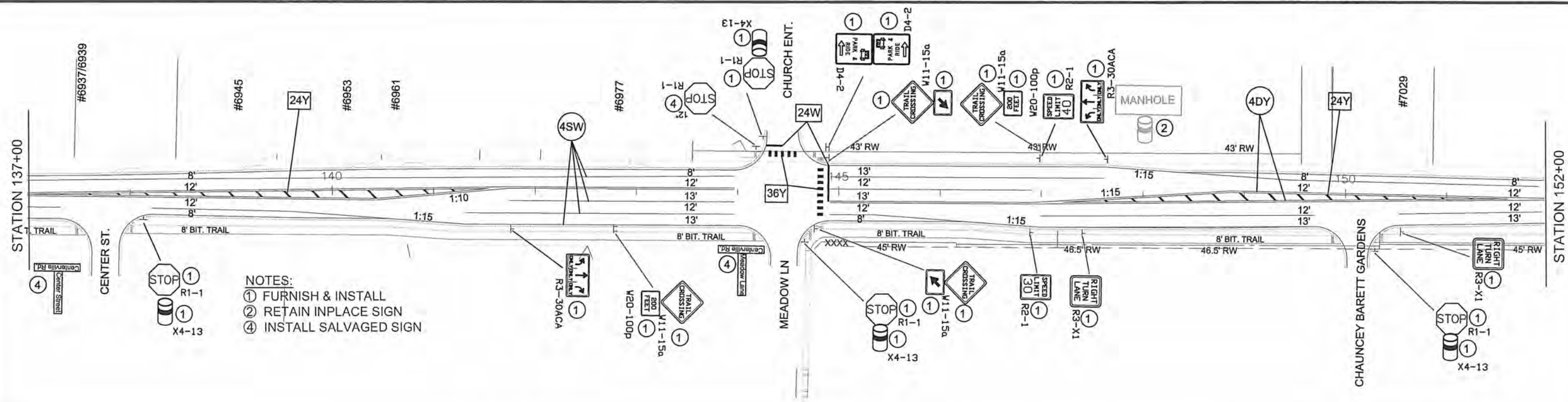

- NOTES:**
- ① FURNISH & INSTALL
 - ② RETAIN INPLACE SIGN
 - ④ INSTALL SALVAGED SIGN

NO	DATE	BY	CKD	APPR	REVISION

NAME: P:\12-01-00\CSAH 21111-13-21_Perm Signing & Striping.dwg

I HEREBY CERTIFY THAT THIS PLAN WAS PREPARED BY ME OR UNDER MY DIRECT SUPERVISION AND THAT I AM A DULY REGISTERED PROFESSIONAL ENGINEER UNDER THE LAWS OF THE STATE OF MINNESOTA.

PRINT NAME: CURT KOBILARCSIK
 SIGNATURE: *Curt Kobilarsik*
 DATE: 7-22-14 REG. NO. 24756

DRAWN BY: RLB DATE: 4/17/14
 DESIGN BY: RLB DATE: 4/17/14
 CHECKED BY: JR DATE: 4/17/14

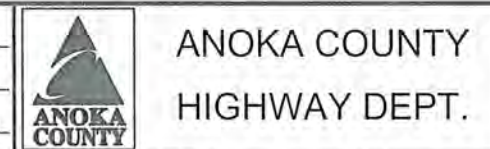

ANOKA COUNTY
 HIGHWAY DEPT.

S.A.P. 002-621-010

PERMANENT SIGNING & STRIPING PLAN

Sheet 95 of 147 Sheets

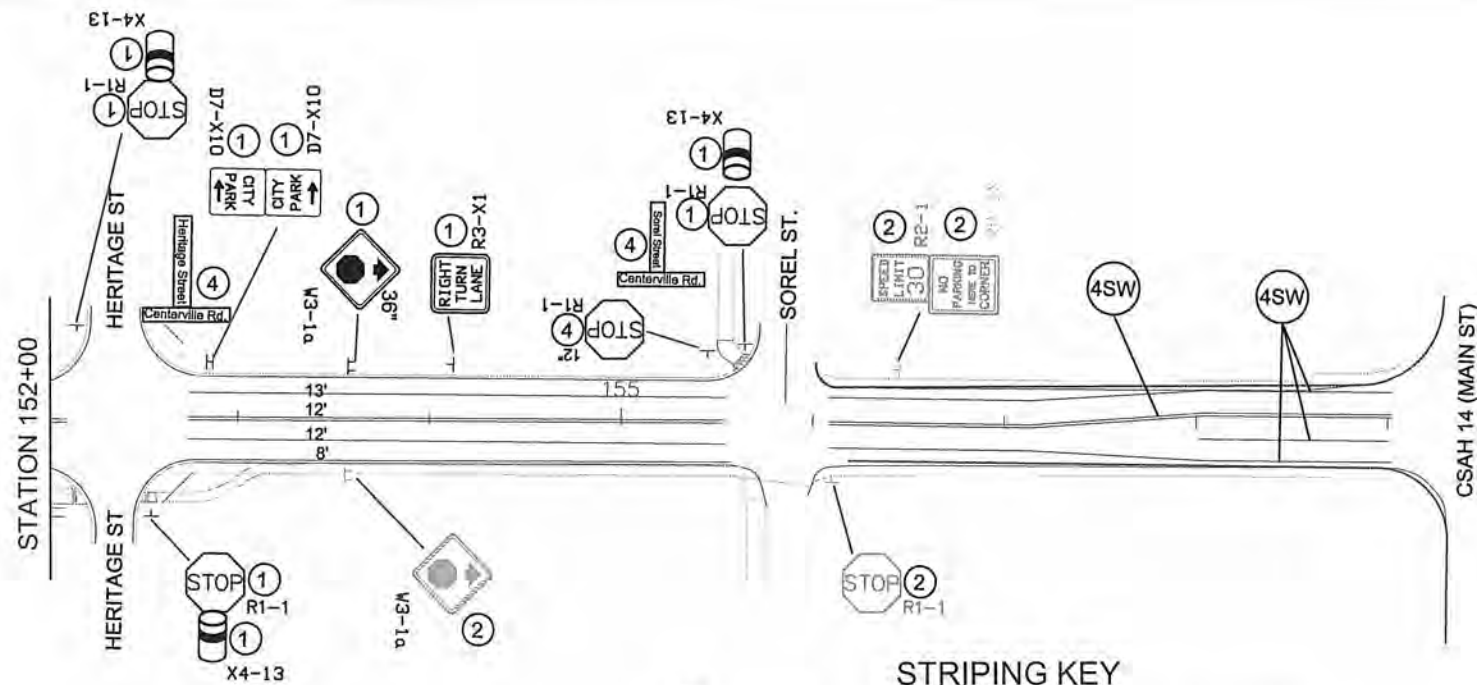

STRIPING KEY

- CIRCLE - EPOXY
- SQUARE - POLY PREFORM
- TRIANGLE - PAINT
- PENTAGON - REMOVABLE PREFORMED PLASTIC MARKING

NOTES:

- ALL TRAFFIC CONTROL DEVICES SHALL CONFORM TO THE MOST RECENT EDITION OF THE MINNESOTA MANUAL ON UNIFORM TRAFFIC CONTROL DEVICES INCLUDING THE FIELD MANUAL DATED JANUARY, 2014
- LOCATIONS OF ALL PERMANENT STRIPING AND PAVEMENT MESSAGES ARE APPROXIMATE. EXACT LOCATIONS SHALL BE DETERMINED IN THE FIELD BY THE ENGINEER.
- ALL MAINLINE PERMANENT STRIPING AND PAVEMENT MESSAGES SHALL BE PLACED WITHIN 72 HOURS OF MAINLINE PAVING.
- SEE PERMANENT SIGN TABULATIONS FOR ADDITIONAL INFORMATION.
- ALL SEGMENT STRIPE LINES SHALL BE EPOXY. PERMANENT MESSAGES AND ARROWS SHALL BE PERFORMED THERMOPLASTIC.
- ALL SIGNS SHALL BE FURNISHED AND INSTALLED UNLESS OTHERWISE NOTED.

NOTES:

- ① FURNISH & INSTALL
- ② RETAIN INPLACE SIGN
- ④ INSTALL SALVAGED SIGN

NO	DATE	BY	CKD	APPR	REVISION

NAME: P:\12-01-00\CSAH 21111-13-21 Perm Signing & Striping.dwg

I HEREBY CERTIFY THAT THIS PLAN WAS PREPARED BY ME OR UNDER MY DIRECT SUPERVISION AND THAT I AM A DULY REGISTERED PROFESSIONAL ENGINEER UNDER THE LAWS OF THE STATE OF MINNESOTA.

PRINT NAME: CURT KOBILARCSIK

SIGNATURE: *Curt Kobilarsik*

DATE: 7-22-14 REG. NO. 24756

DRAWN BY: RLB DATE: 4/17/14

DESIGN BY: RLB DATE: 4/17/14

CHECKED BY: JR DATE: 4/17/14



ANOKA COUNTY
HIGHWAY DEPT.

S.A.P. 002-621-010

PERMANENT SIGNING &
STRIPING PLAN

SIGN PANELS TYPE C							E
M.U.T.C.D. CODE	SIZE	INSERT	QUANTITY	SQ FT PANEL AREA	SQ FT TOTAL AREA	MOUNTING POST PER INSTALLATION	MOUNTING HEIGHT
R1-1	30" x 30"		10	6.25	62.50	1	7.0'
R1-1	36" x 36"		1	9.00	9.00	2	7.0'
R1-1	48" x 48"		2	16.00	32.00	2	7.0'
R1-4	18" x 6"		2	.75	1.50		
X4-13	4" diameter x 15"			13	1.31	0	
R3-X1	30" x 30"		6	6.25	37.5	1	7.0'
R3-30ACA	54" x 30"		4	11.25	45.00	2	7.0'
R4-7	36" x 36"		2	9.00	18.00	2	7.0'
X4-2	48" x 48"		1	16.00	16.00	2	7.0'
W14-3	48" x 36"		1	6.00	6.00	2	7.0'
W11-15a	36" x 36"		8	9.00	72.00	2	7.0'
W20-100P	30" x 24"		2	5.00	10.00		
			2	5.00	10.00		
W16-7mP	30" x 24"		4	5.00	20.00		
R2-1	24" x 30"		2	5.00	10.00	1	7.0'
R2-1	24" x 30"		2	5.00	10.00	1	7.0'
R2-1	24" x 30"		1	5.00	5.00	1	7.0'
M3-1a	24" x 12"		1	2.00	2.00		
M1-6	24" x 24"		2	4.00	8.00	1	7.0'
M6-4A	21" x 15"			1	2.18	2.18	
M2-1a	21" x 15"		1	2.18	2.00		
M1-6	24" x 24"		2	4.00	8.00	1	7.0'
M6-4A	21" x 15"			1	2.18	2.18	
D4-2	30" x 36"		2	7.5	15.00	1	7.0'
D7-X10	30" x 36"		2	7.5	15.00	1	7.0'
TOTAL			45		418.86		

NOTES:

- ALL TRAFFIC CONTROL DEVICES SHALL CONFORM TO THE MOST RECENT EDITION OF THE MINNESOTA MANUAL ON UNIFORM TRAFFIC CONTROL DEVICES INCLUDING THE FIELD MANUAL DATED JANUARY, 2014
- LOCATIONS OF ALL PERMANENT STRIPING AND PAVEMENT MESSAGES ARE APPROXIMATE. EXACT LOCATIONS SHALL BE DETERMINED IN THE FIELD BY THE ENGINEER.
- ALL MAINLINE PERMANENT STRIPING AND PAVEMENT MESSAGES SHALL BE PLACED WITHIN 72 HOURS OF MAINLINE PAVING.
- SEE PERMANENT SIGN TABULATIONS FOR ADDITIONAL INFORMATION.
- ALL SEGMENT STRIPE LINES SHALL BE EPOXY. PERMANENT MESSAGES AND ARROWS SHALL BE PREFORMED THERMOPLASTIC.
- ALL SIGNS SHALL BE FURNISHED AND INSTALLED UNLESS OTHERWISE NOTED.

NO	DATE	BY	CKD	APPR	REVISION

I HEREBY CERTIFY THAT THIS PLAN WAS PREPARED BY ME OR UNDER MY DIRECT SUPERVISION AND THAT I AM A DULY REGISTERED PROFESSIONAL ENGINEER UNDER THE LAWS OF THE STATE OF MINNESOTA.

PRINT NAME: CURT KOBILARCSIK
SIGNATURE:
DATE: 7-14-14 REG. NO. 24756

DRAWN BY: RLB DATE: 4/17/14
DESIGN BY: RLB DATE: 4/17/14
CHECKED BY: JR DATE: 4/17/14



ANOKA COUNTY
HIGHWAY DEPT.

S.A.P. 002-621-010

PERMANENT SIGNING
QUANTITY

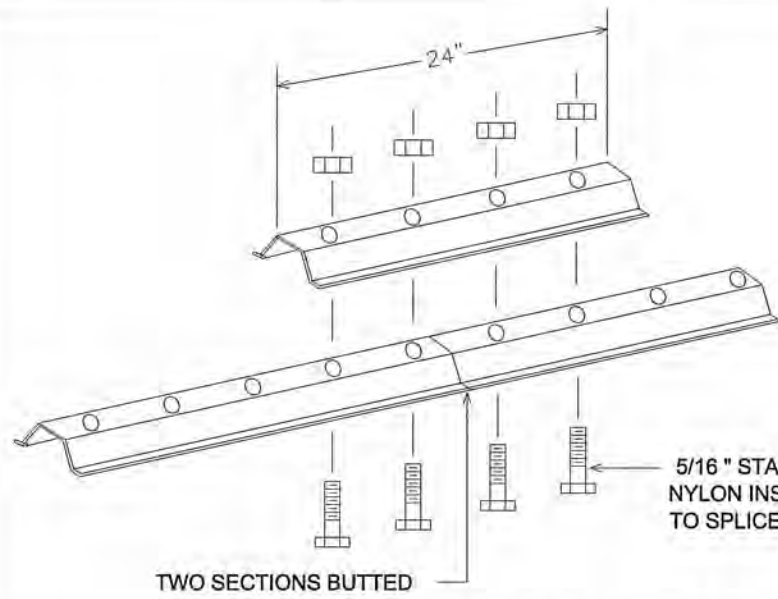

LATERAL BRACE OR STRINGER SPLICE DETAIL (EXPLODED VIEW)

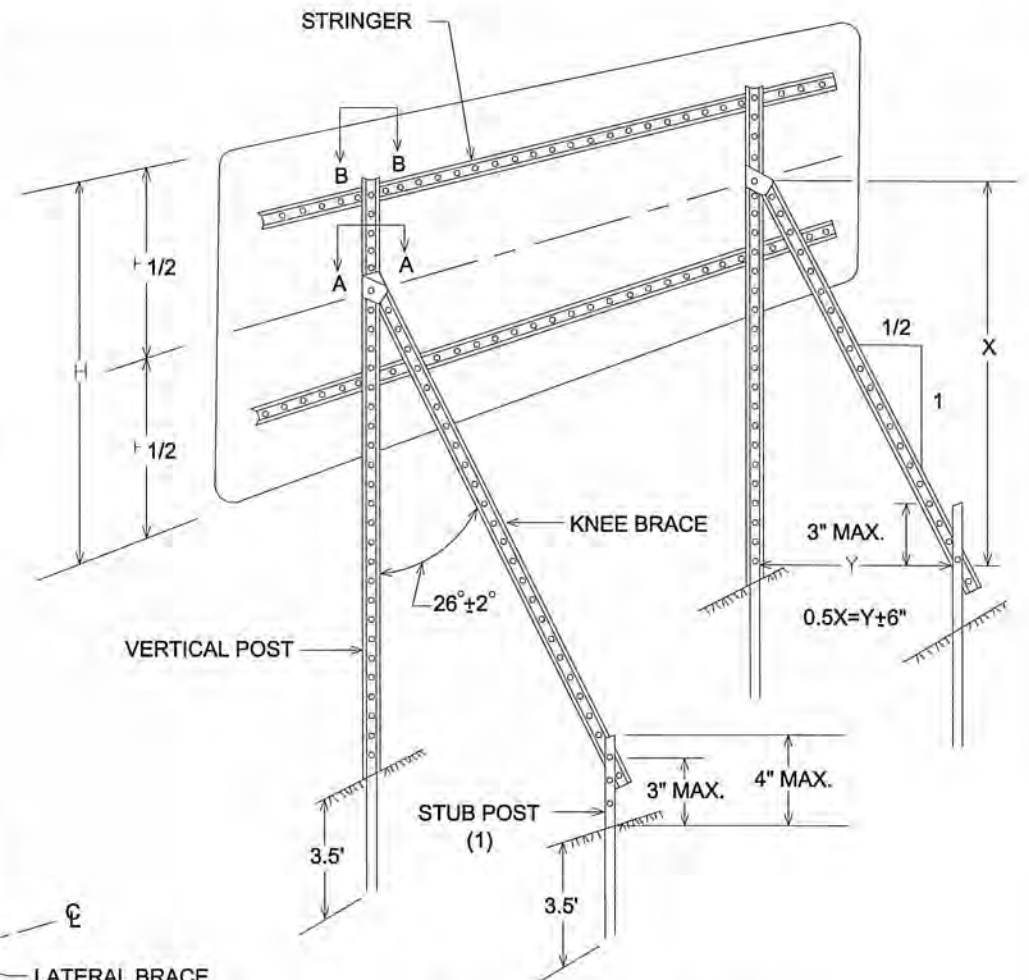
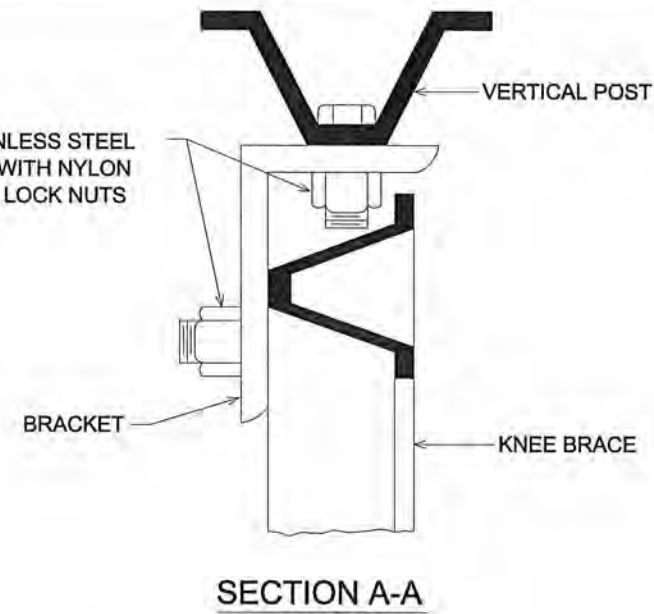

TYPICAL "A-FRAME" INSTALLATION TYPE "D" SIGNS

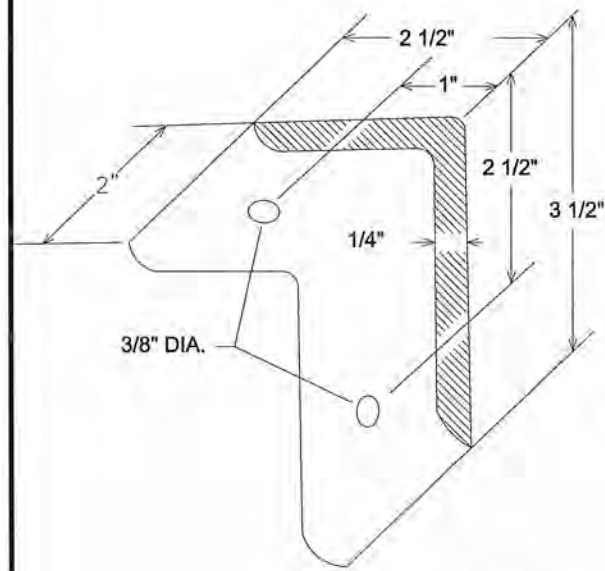

A-FRAME BRACKET

(STEEL MN/DOT 3306 GALVANIZED PER MN/DOT 3394)

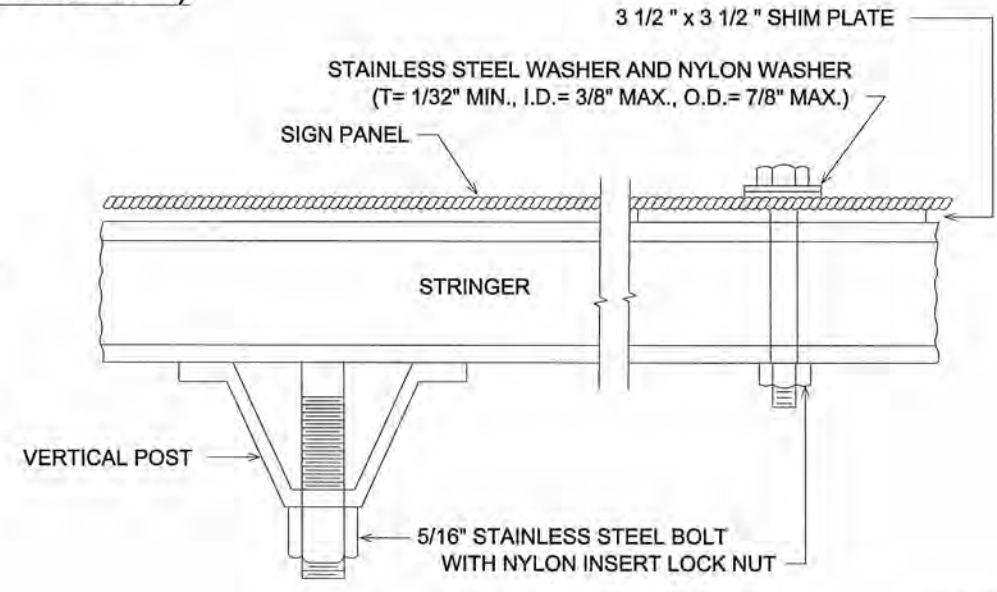

SECTION B-B

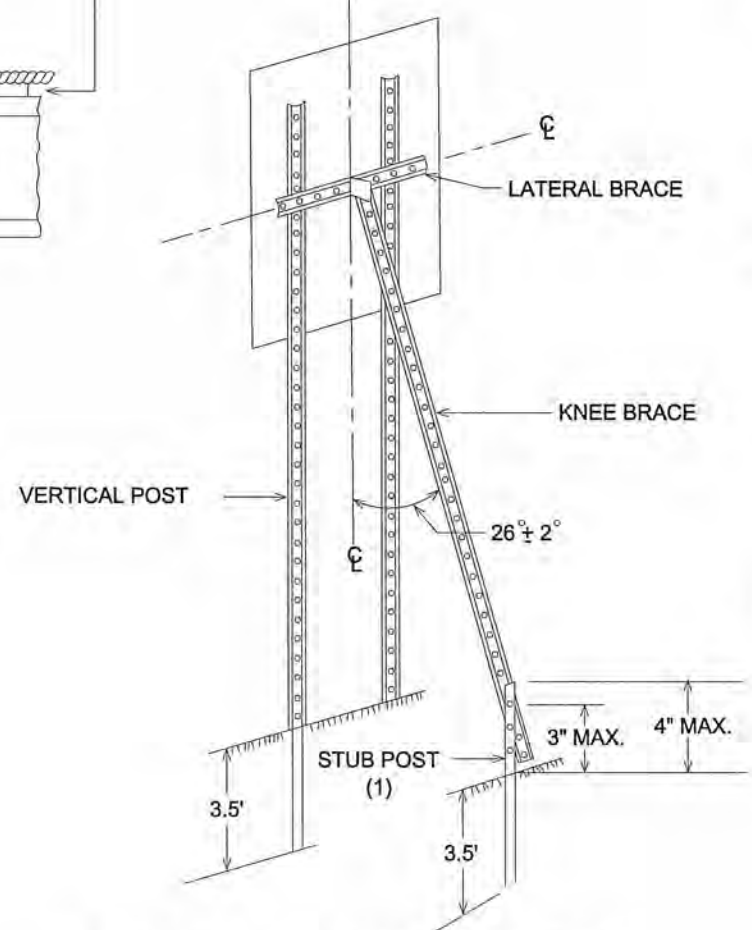
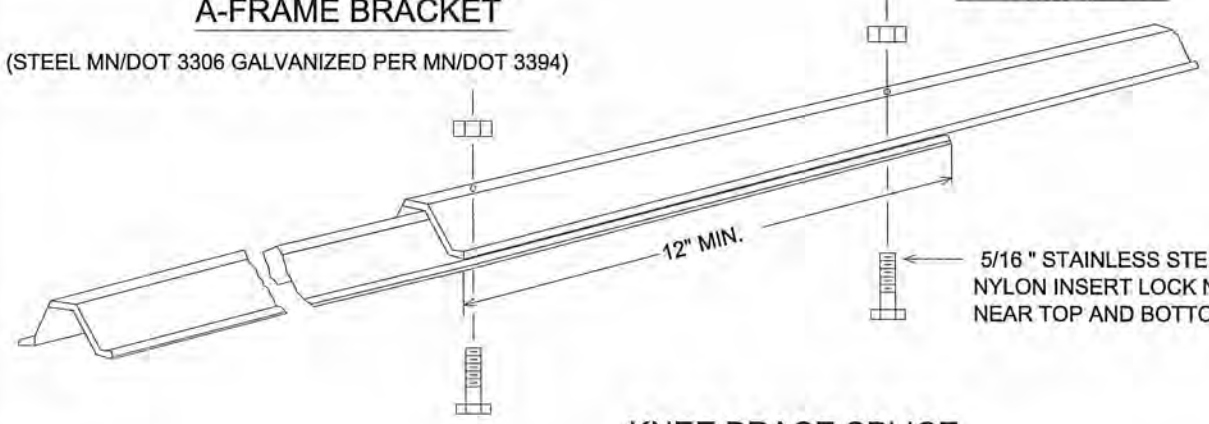

TYPICAL "A-FRAME" INSTALLATION TYPE "C" SIGNS

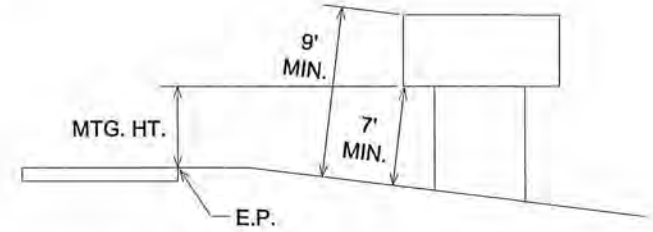

TYPICAL MOUNTING

(1) OFFSET STUB POST 1' TOWARD ROADWAY RELATIVE TO VERTICAL POST.

TYPE C & D SIGN STRUCTURAL DETAILS

NO	DATE	BY	CKD	APPR	REVISION

I HEREBY CERTIFY THAT THIS PLAN WAS PREPARED BY ME OR UNDER MY DIRECT SUPERVISION AND THAT I AM A DULY REGISTERED PROFESSIONAL ENGINEER UNDER THE LAWS OF THE STATE OF MINNESOTA.

PRINT NAME: CURT KOBILARCSIK

SIGNATURE: *Curt Kobilarsik*

DATE: 7-14-14 REG. NO. 24756

DRAWN BY: RLB DATE: 4/17/14

DESIGN BY: RLB DATE: 4/17/14

CHECKED BY: JR DATE: 4/17/14



ANOKA COUNTY
HIGHWAY DEPT.

S.A.P. 002-621-010

SIGNING & STRIPING
DETAILS

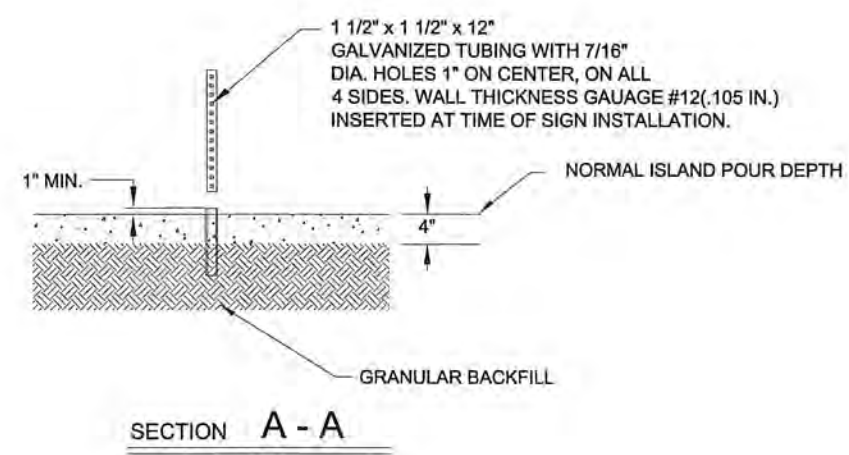
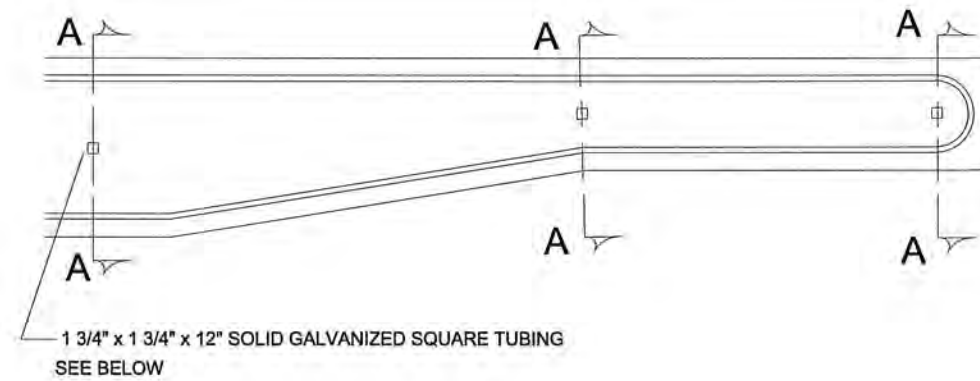

GROUND POST MOUNT SIGN INSTALLATION TYPICAL

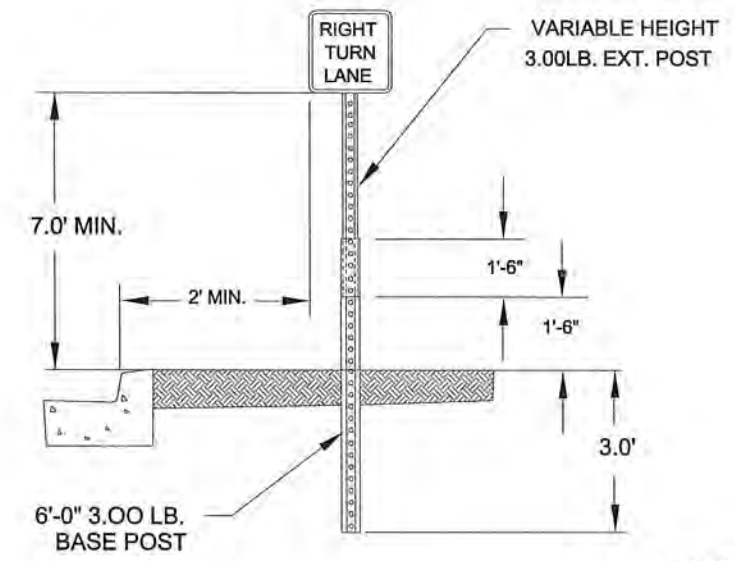

ISLAND MOUNT BREAK-AWAY SIGN INSTALLATION TYPICAL

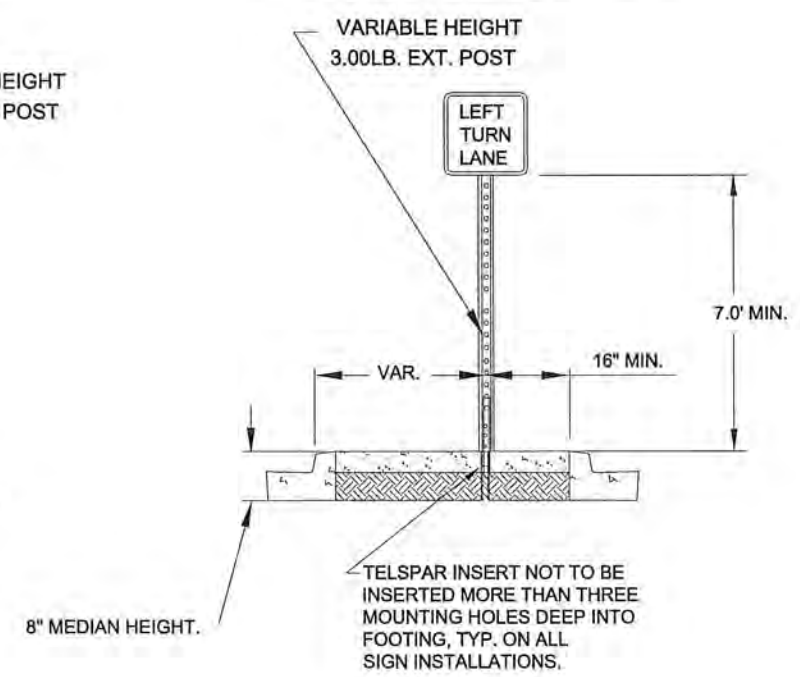

NO	DATE	BY	CKD	APPR	REVISION

I HEREBY CERTIFY THAT THIS PLAN WAS PREPARED BY ME OR UNDER MY DIRECT SUPERVISION AND THAT I AM A DULY REGISTERED PROFESSIONAL ENGINEER UNDER THE LAWS OF THE STATE OF MINNESOTA.

PRINT NAME: CURT KOBILARCSIK

SIGNATURE: *Curt Kobilarsik*

DATE: 7-14-14 REG. NO. 24756

DRAWN BY: RLB DATE 4/17/14

DESIGN BY: RLB DATE 4/17/14

CHECKED BY: JR DATE 4/17/14



ANOKA COUNTY
HIGHWAY DEPT.

S.A.P. 002-621-010

SIGNING & STRIPING
DETAILS

Sheet 99 of 147 Sheets

RURAL

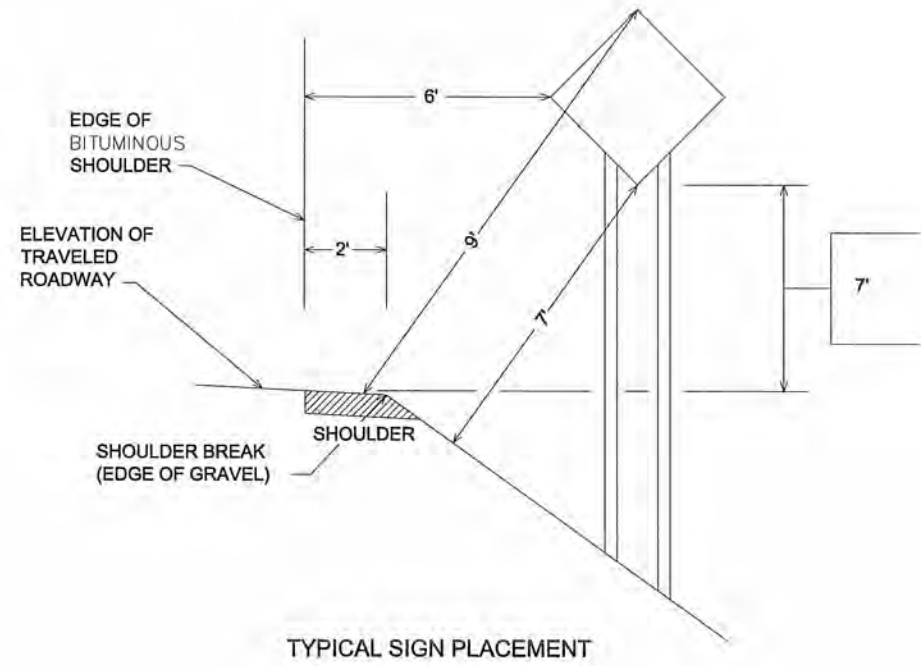

URBAN

* 2' - NARROW BOULEVARD (< 8' WIDE)
6' - WIDE BOULEVARD

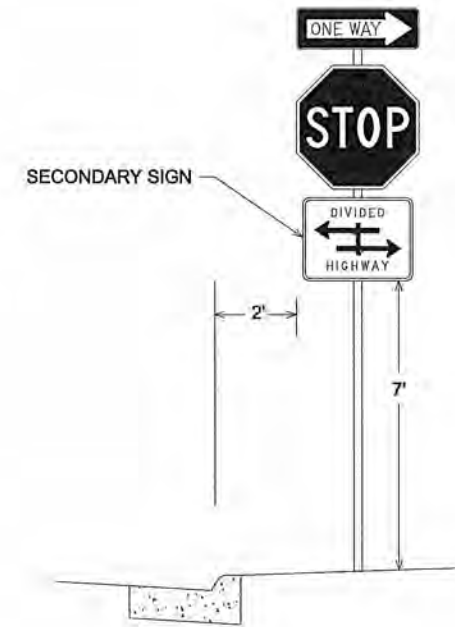
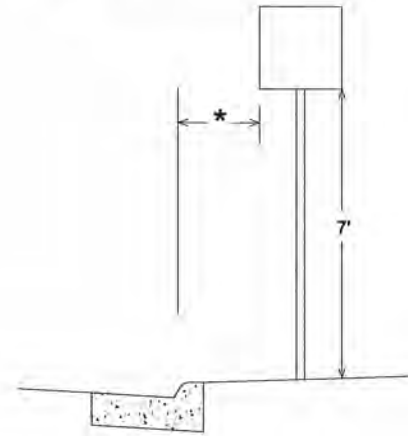

NOTE:

- ALL DIMENSIONS ARE MINIMUMS
- MAINTAIN 2' CLEAR FROM SIGNS TO BITUMINOUS TRAIL

I HEREBY CERTIFY THAT THIS PLAN WAS PREPARED BY ME OR UNDER MY DIRECT SUPERVISION AND THAT I AM A DULY REGISTERED PROFESSIONAL ENGINEER UNDER THE LAWS OF THE STATE OF MINNESOTA.

PRINT NAME: CURT KOBILARCSIK

SIGNATURE: *Curt Kobilarsik*

DATE: 7-14-14 REG. NO. 24756

DRAWN BY: RLB DATE: 4/17/14

DESIGN BY: RLB DATE: 4/17/14

CHECKED BY: JR DATE: 4/17/14



ANOKA COUNTY
HIGHWAY DEPT.

S.A.P. 002-621-010

SIGNING & STRIPING
DETAILS

Sheet 100 of 147 Sheets

NO	DATE	BY	CKD	APPR	REVISION

**TYPICAL MESSAGE PLACEMENT
FOR TURN LANES**

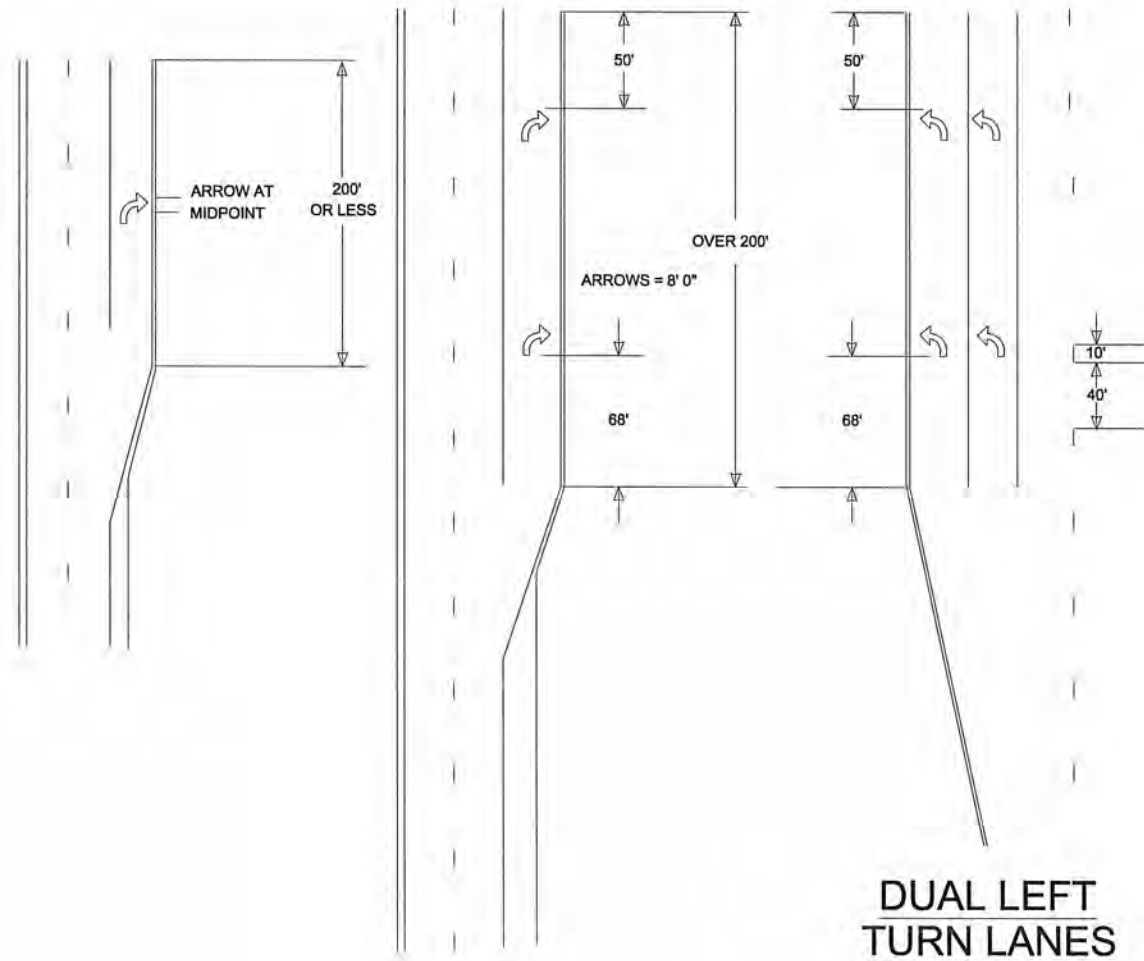

**TYPICAL MARKINGS FOR
LEFT TURN ISLANDS**

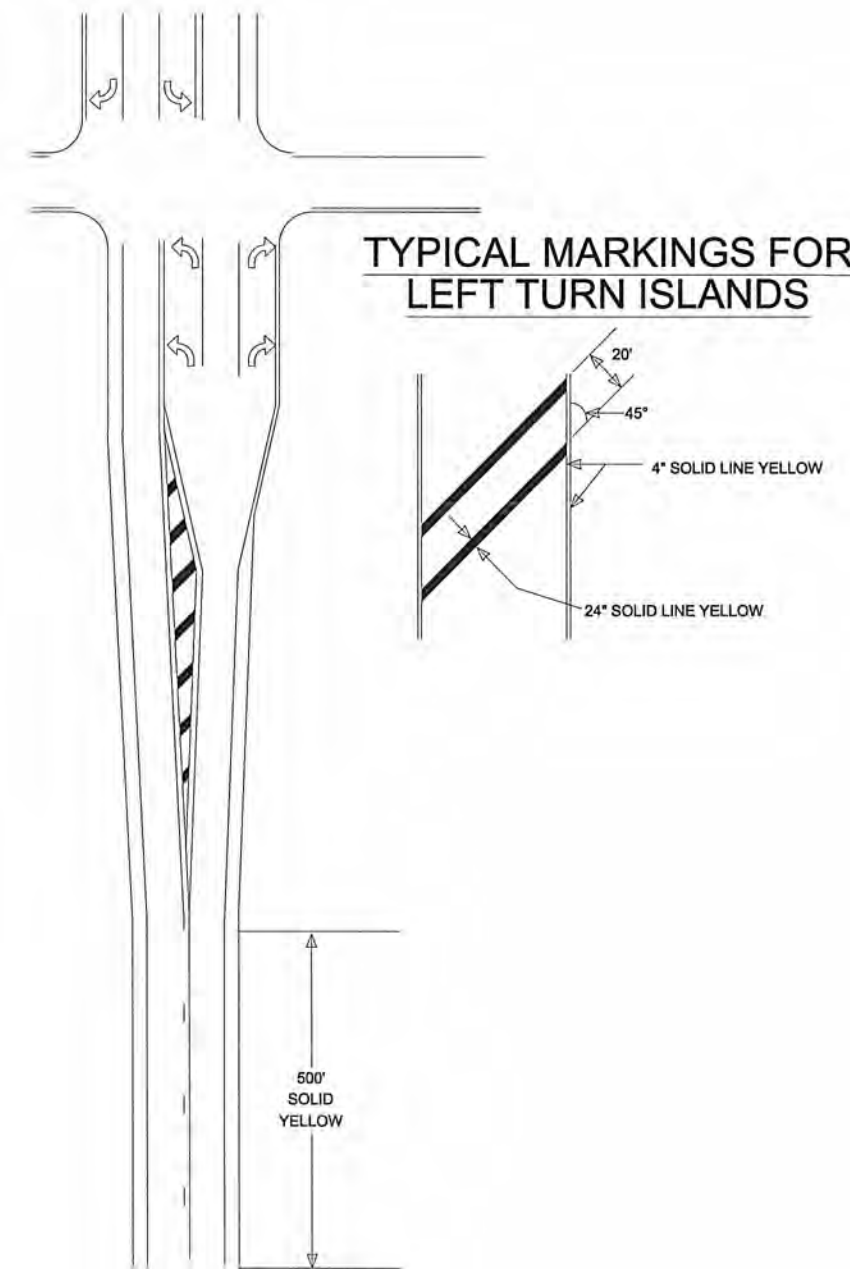

NO	DATE	BY	CKD	APPR	REVISION

I HEREBY CERTIFY THAT THIS PLAN WAS PREPARED BY ME OR UNDER MY DIRECT SUPERVISION AND THAT I AM A DULY REGISTERED PROFESSIONAL ENGINEER UNDER THE LAWS OF THE STATE OF MINNESOTA.

PRINT NAME: CURT KOBILARCSIK

SIGNATURE: *Curt Kobilarsik*

DATE: 7-14-14 REG. NO. 24756

DRAWN BY: RLB DATE: 4/17/14

DESIGN BY: RLB DATE: 4/17/14

CHECKED BY: JR DATE: 4/17/14



ANOKA COUNTY
HIGHWAY DEPT.

S.A.P. 002-621-010

SIGNING & STRIPING
DETAILS

Sheet 101 of 147 Sheets

MARKINGS FOR PEDESTRIAN CROSSWALKS

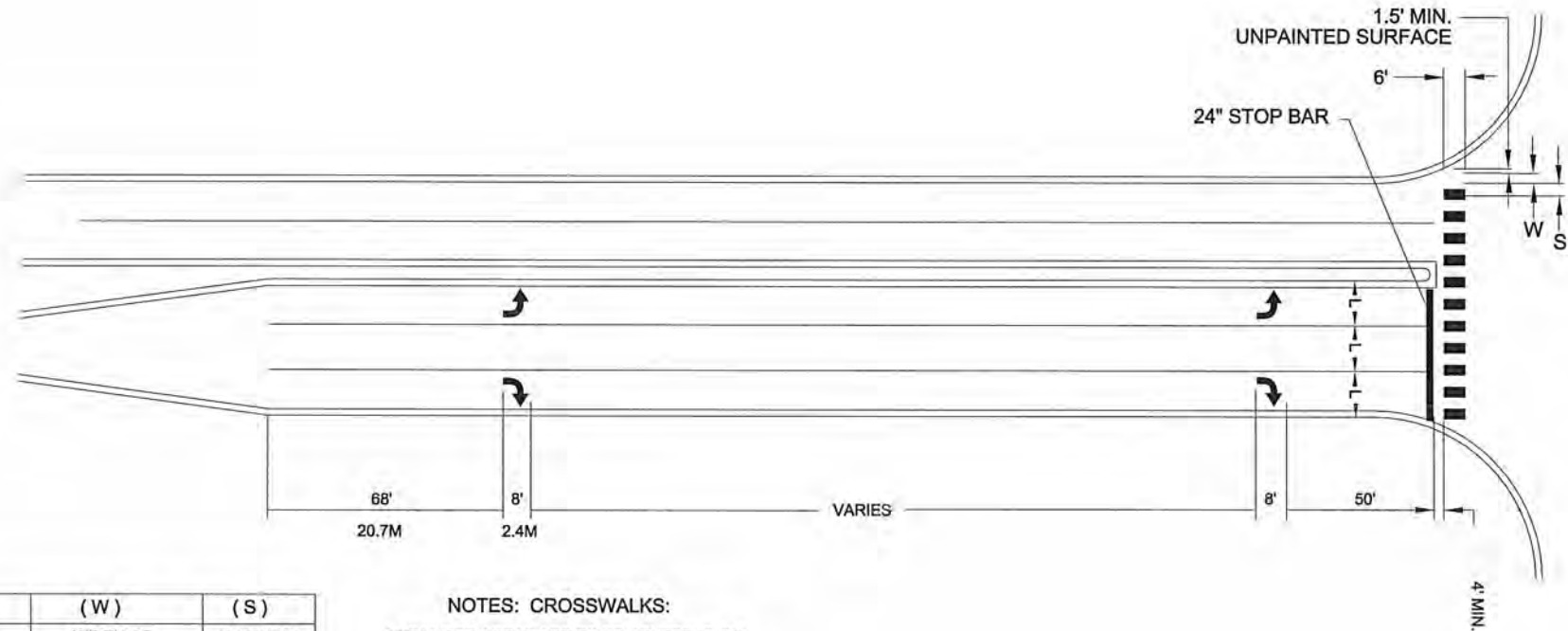

(L)	(W)	(S)
WIDTH OF INSIDE LANE	WIDTH OF PAINTED AREAS	WIDTH OF SPACE
9'	2.0'	2.5'
10'	2.5'	2.5'
11'	2.5'	3.0'
12'	3.0'	3.0'
13'	3.0'	3.5'

NOTES: CROSSWALKS:

- 1.) PAINTED AREAS ARE TO BE CENTERED ON CENTER AND LANE LINES, EVEN IF INTERSECTION IS NOT ALIGNED.
- 2.) LOCATION OF ZEBRA CROSSWALKS AND STOP BARS, SIGNAL LOOPS AND PED RAMPS ARE APPROXIMATE. FINAL LOCATIONS ARE TO BE DETERMINED AND FIELD VERIFIED DURING CONSTRUCTION BY THE FIELD ENGR.
- 3.) ZEBRA CROSSWALKS ARE TO BE PARALLEL TO THE DRIVING LANE OR LANES, EVEN IF THE STREET IS ON AN ANGLE TO THE INTERSECTION.
- 4.) A MIN. OF 1.5' (450mm) CLEAR DISTANCE MUST BE LEFT ADJACENT TO THE CURB. IF LAST PAINTED AREA FALLS INTO THIS AREA, IT MUST BE OMITTED.
- 5.) ON TWO LANE STREETS, USE SPACING SHOWN FOR AN 11' (3.3mm) INSIDE LANE.

I HEREBY CERTIFY THAT THIS PLAN WAS PREPARED BY ME OR UNDER MY DIRECT SUPERVISION AND THAT I AM A DULY REGISTERED PROFESSIONAL ENGINEER UNDER THE LAWS OF THE STATE OF MINNESOTA.
 PRINT NAME: CURT KOBILARCSIK
 SIGNATURE: *Curt Kobilarsik*
 DATE: 7-14-14 REG. NO. 24756

DRAWN BY: RLB DATE: 4/17/14
 DESIGN BY: RLB DATE: 4/17/14
 CHECKED BY: JR DATE: 4/17/14



ANOKA COUNTY
 HIGHWAY DEPT.

S.A.P. 002-621-010

SIGNING & STRIPING
 DETAILS

NO	DATE	BY	CKD	APPR	REVISION

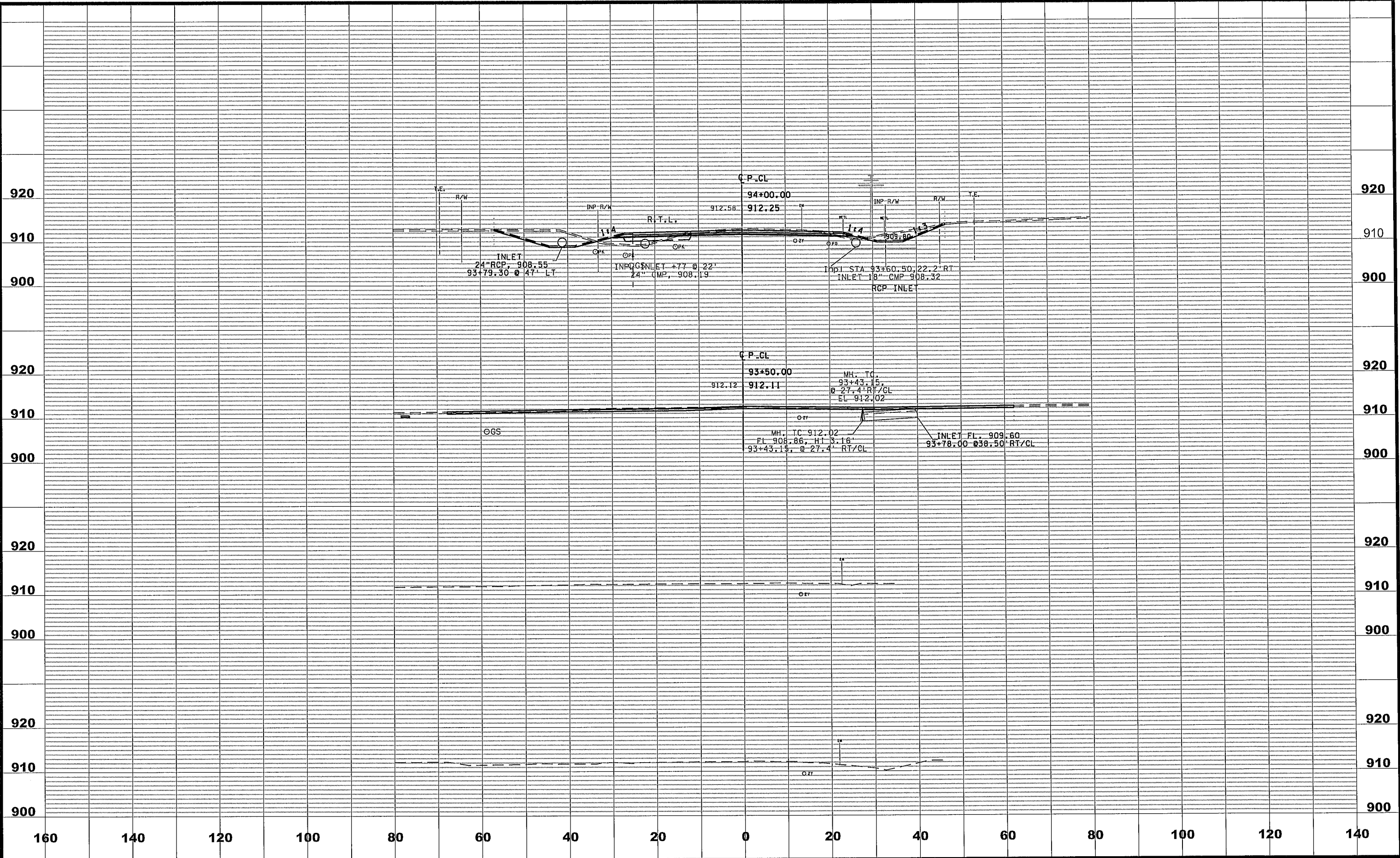

NO	DATE	BY	CKD	APPR	REVISION

NAME: P:\02-621-10\Plan\0262110_XS1_sh.dgn 07/11/2014 2:13:35 PM

DRAWN BY ZB DATE 07-07-14
 DESIGN BY MN DATE 07-07-14
 CHECKED BY CAK DATE 07-11-14

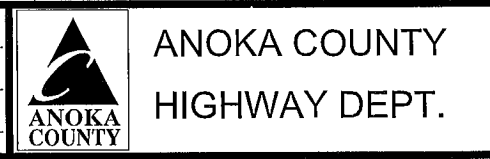

S.A.P. 002-621-010

CROSS SECTIONS
 STA 93+50.00 TO 94+00.00
 Sheet 103 of 147 Sheets

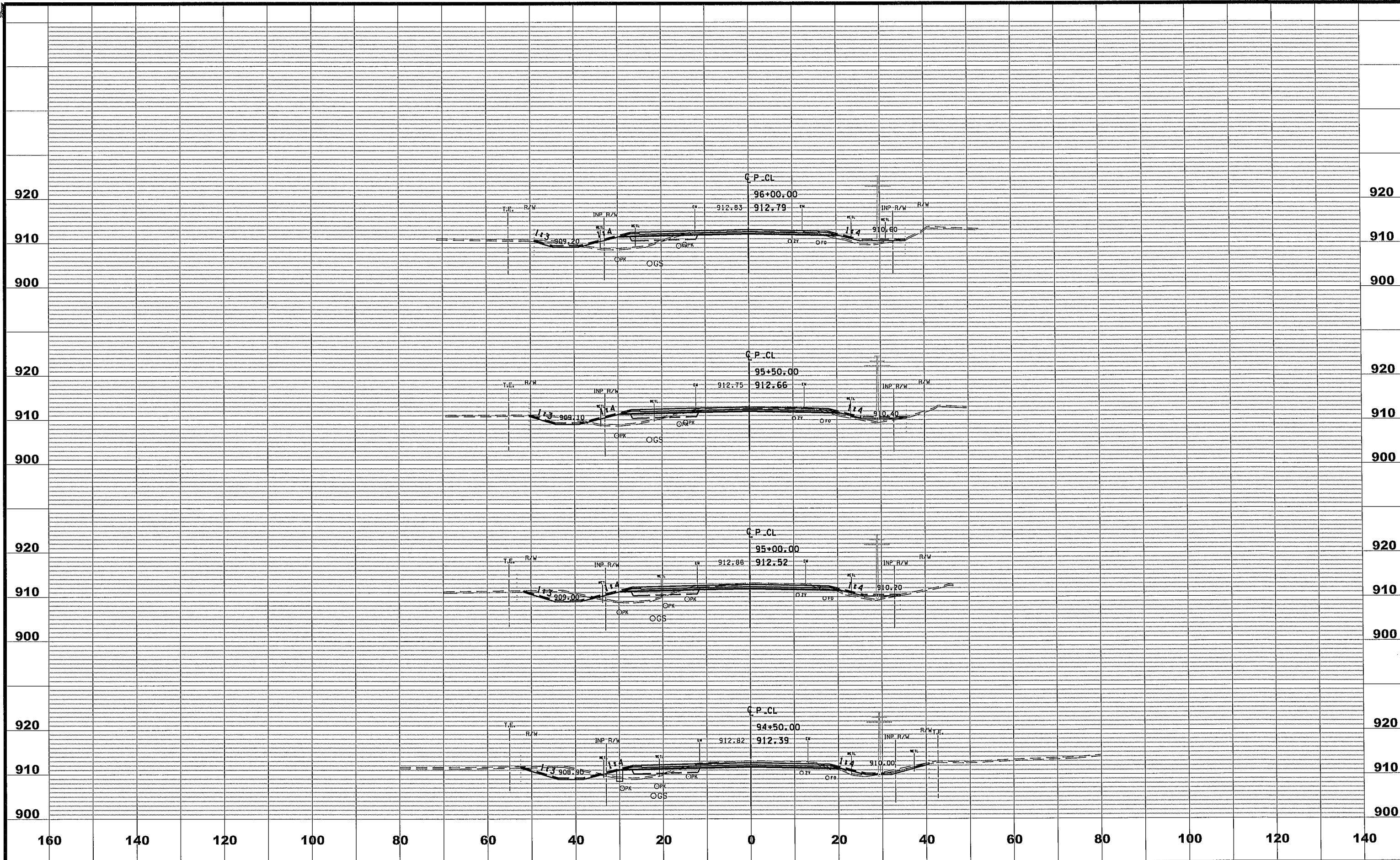

NO	DATE	BY	CKD	APPR	REVISION
NAME: P:\02-621-10\Plan\0262110_XS1_sh.dgn					
07/11/2014 2:13:35 PM					

DRAWN BY ZB DATE 07-07-14
 DESIGN BY MN DATE 07-07-14
 CHECKED BY CAK DATE 07-11-14

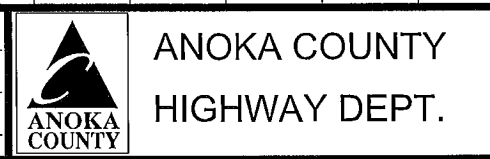

S.A.P. 002-621-010

CROSS SECTIONS
 STA 94+50.00 TO 96+00.00
 Sheet 104 of 147 Sheets

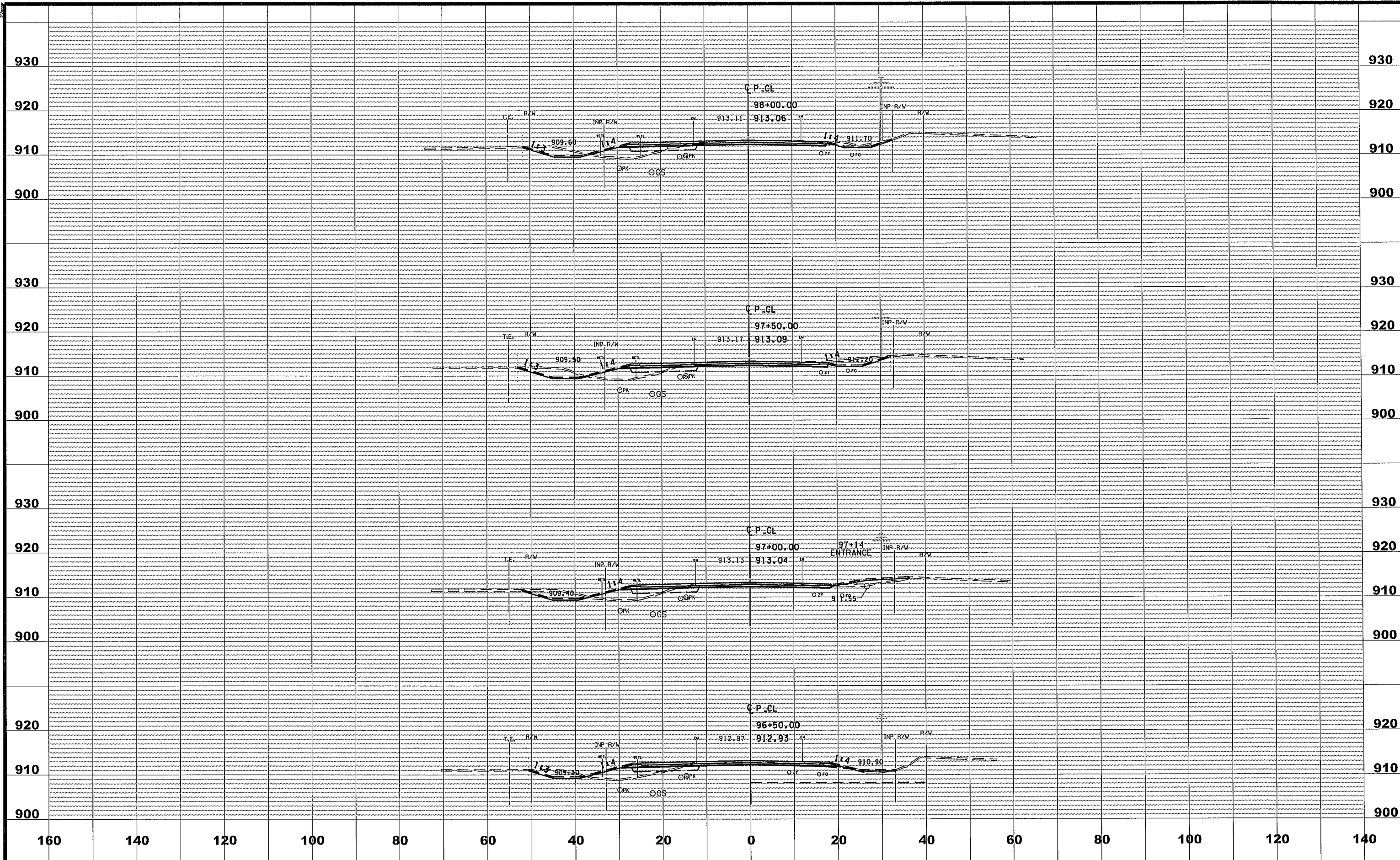

NO	DATE	BY	CKD	APPR	REVISION

NAME: P:\02-621-10\Plan\0262110_XS1_sh.dgn 07/11/2014 2:13:36 PM

DRAWN BY ZB DATE 07-07-14
 DESIGN BY MN DATE 07-07-14
 CHECKED BY CAK DATE 07-11-14

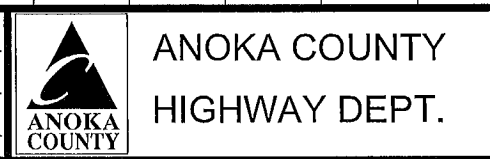

S.A.P. 002-621-010

CROSS SECTIONS
 STA 96+50.00 TO 98+00.00
 Sheet 105 of 147 Sheets

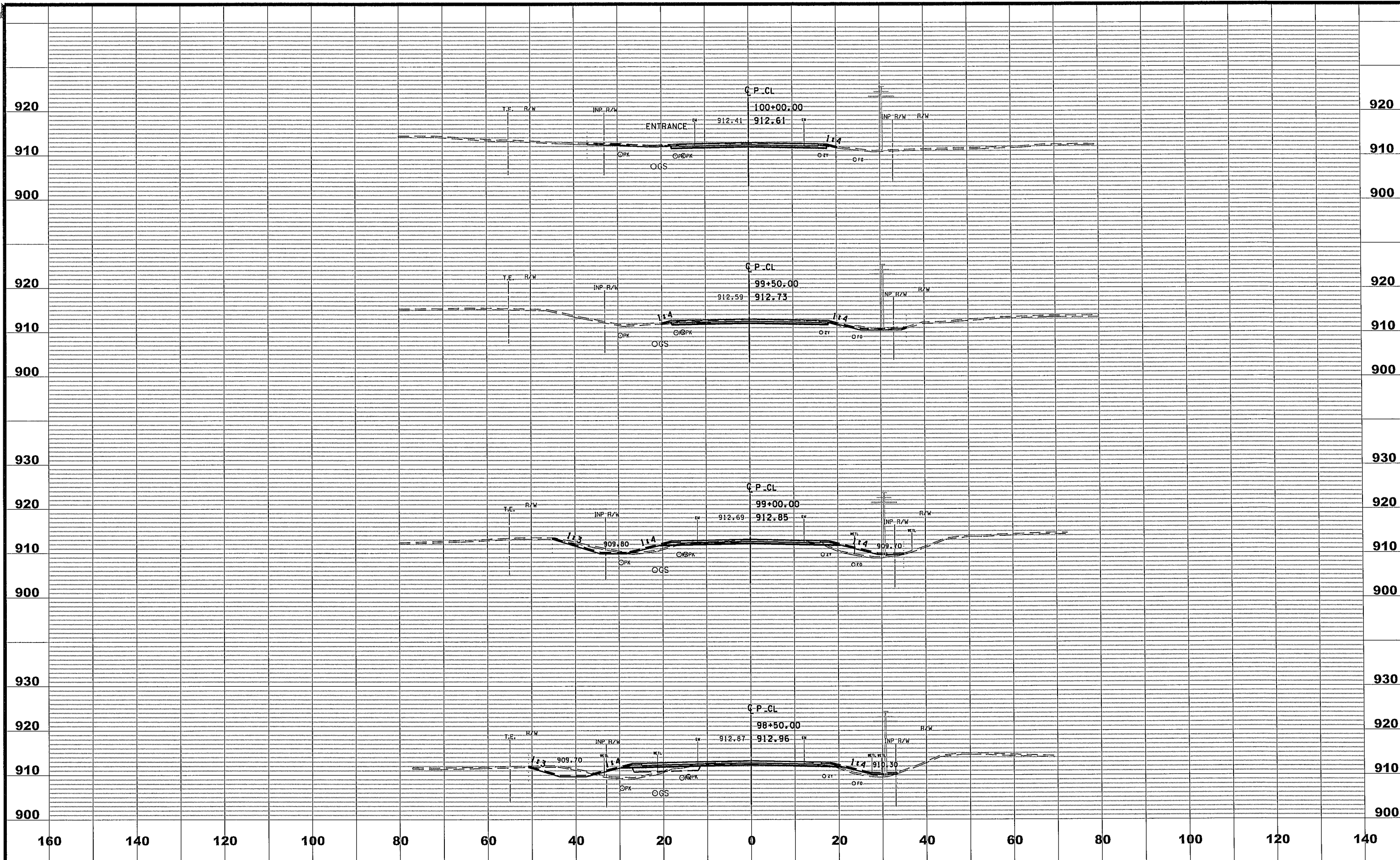

NO	DATE	BY	CKD	APPR	REVISION

NAME: P:\02-621-10\Plan\0262110_XS1_sh.dgn 07/11/2014 2:13:36 PM

DRAWN BY ZB DATE 07-07-14
 DESIGN BY MN DATE 07-07-14
 CHECKED BY CAK DATE 07-11-14

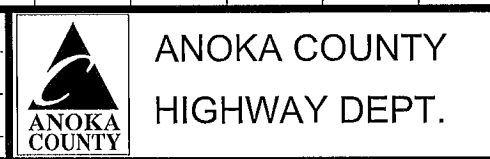

S.A.P. 002-621-010

CROSS SECTIONS
 STA 98+50.00 TO 100+00.00
 Sheet 106 of 147 Sheets

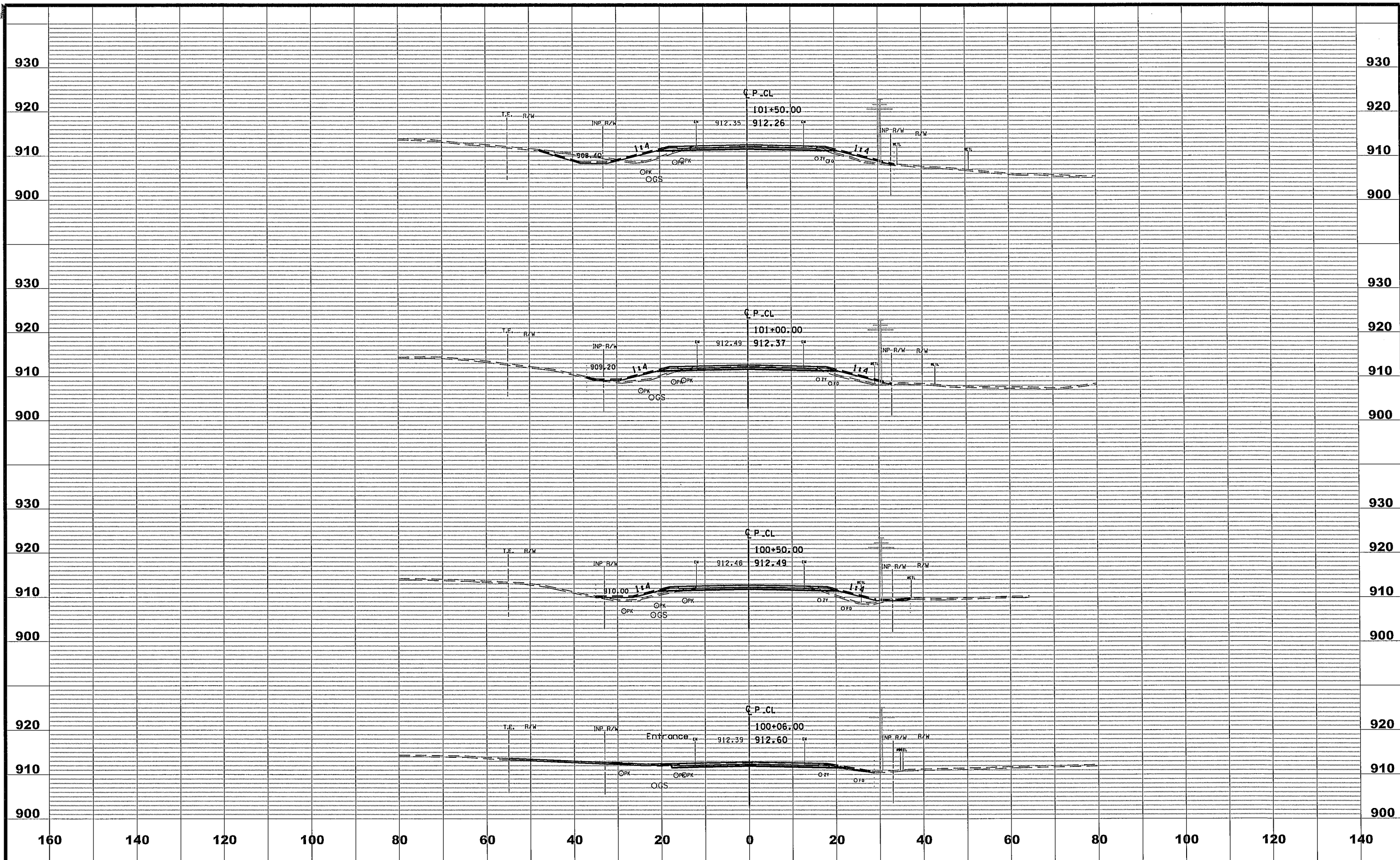

NO	DATE	BY	CKD	APPR	REVISION
NAME: P:\02-621-10\Plan\0262110_XS1_sh.dgn					
07/11/2014 2:13:36 PM					

DRAWN BY ZB DATE 07-07-14
 DESIGN BY MN DATE 07-07-14
 CHECKED BY CAK DATE 07-11-14

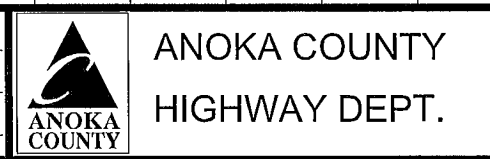

S.A.P. 002-621-010

CROSS SECTIONS
 STA 100+06.00 TO 101+50.00
 Sheet 107 of 147 Sheets

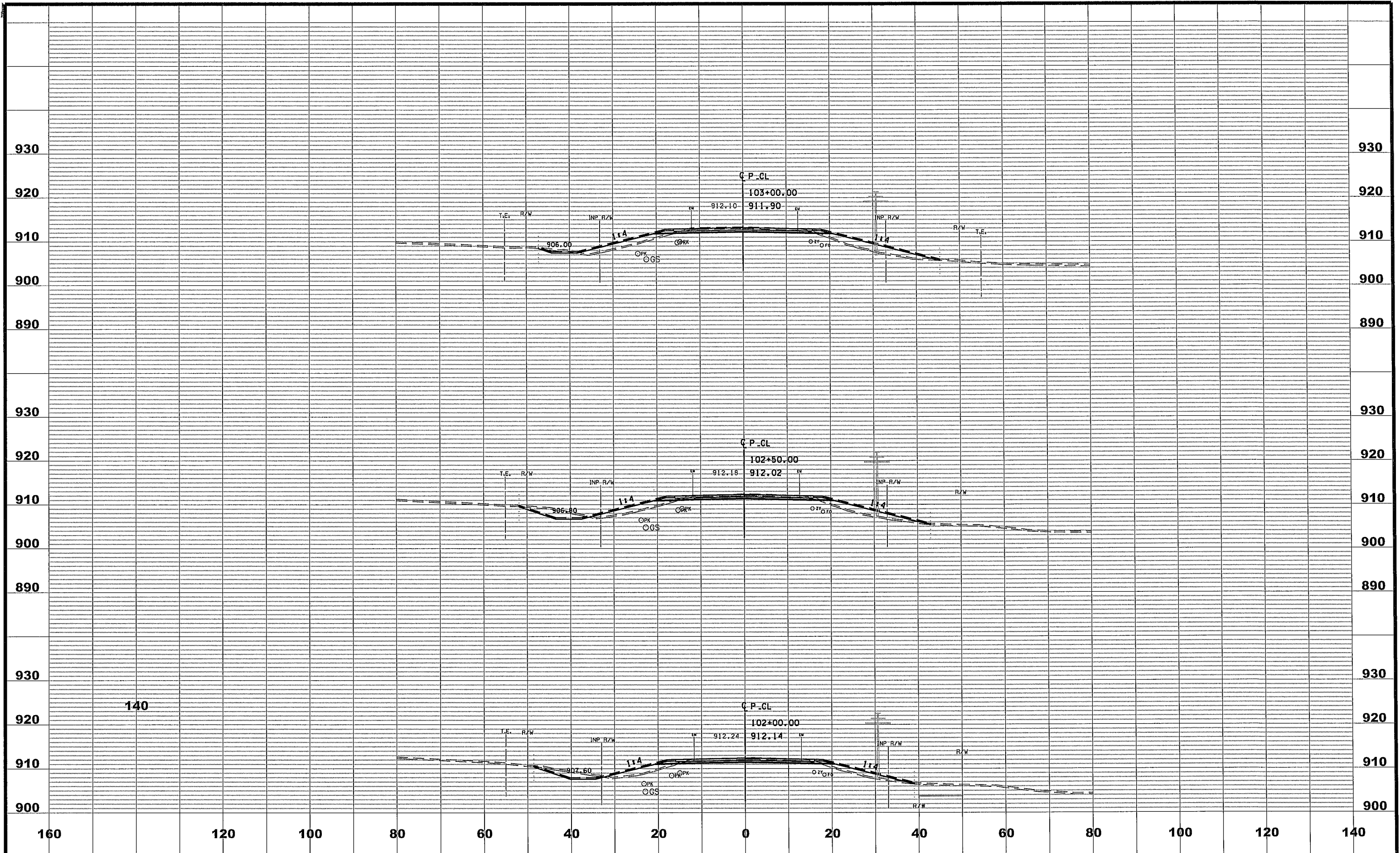

140

NO	DATE	BY	CKD	APPR	REVISION

NAME: P:\02-621-10\Plan\0262110_XS1_sh.dgn 07/11/2014 2:13:37 PM

DRAWN BY ZB DATE 07-07-14
 DESIGN BY MN DATE 07-07-14
 CHECKED BY CAK DATE 07-11-14

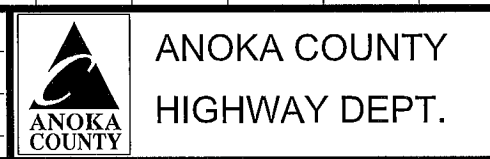

S.A.P. 002-621-010

CROSS SECTIONS
 STA 102+00.00 TO 103+00.00
 Sheet 108 of 147 Sheets

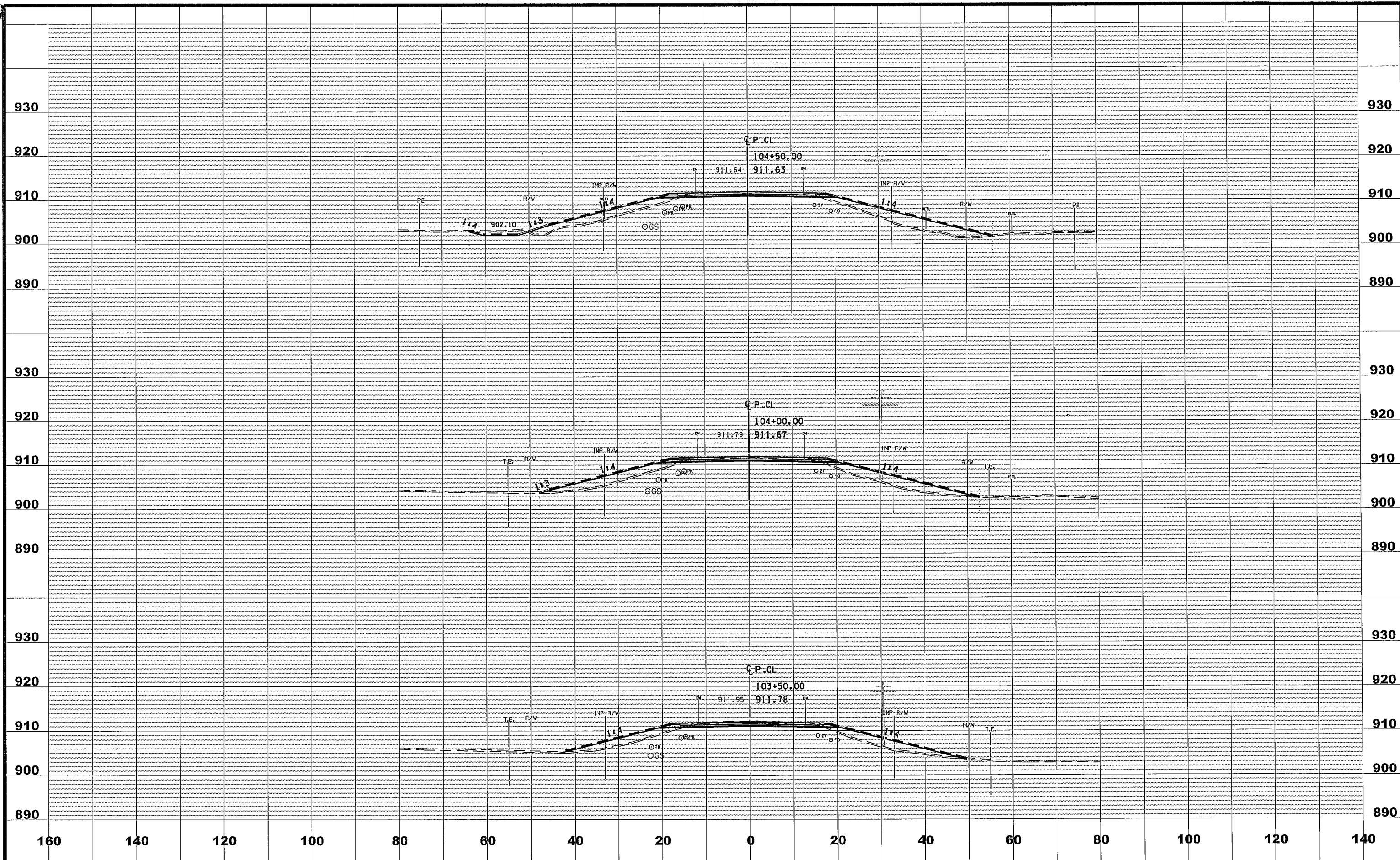

NO	DATE	BY	CKD	APPR	REVISION

NAME: P:\02-621-10\Plan\0262110_XS1_sh.dgn 07/11/2014 2:13:37 PM

DRAWN BY ZB DATE 07-07-14
 DESIGN BY MN DATE 07-07-14
 CHECKED BY CAK DATE 07-11-14

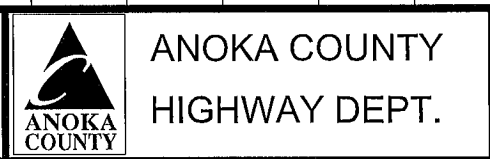

S.A.P. 002-621-010

CROSS SECTIONS
 STA 103+50.00 TO 104+50.00
 Sheet 109 of 147 Sheets

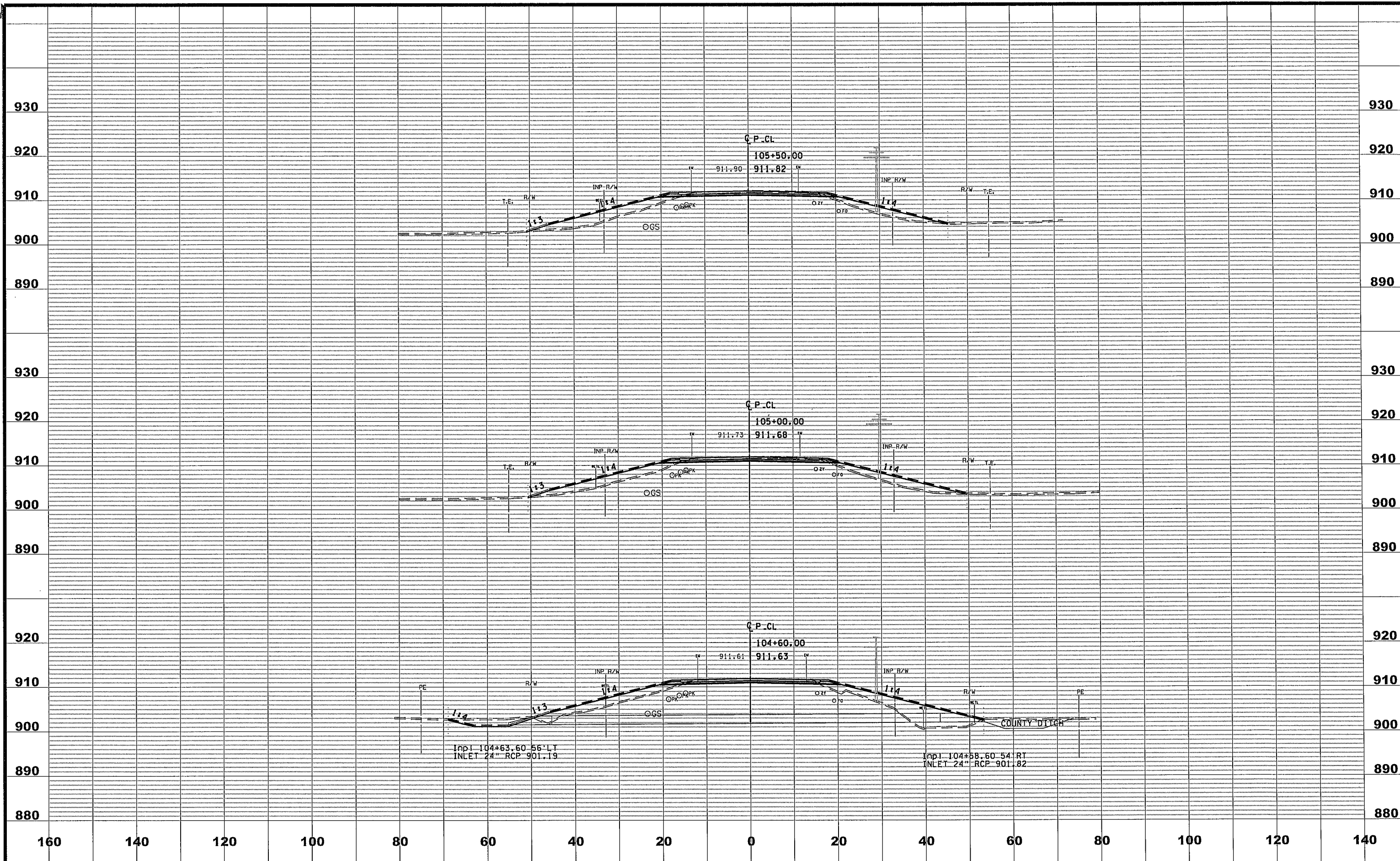

NO	DATE	BY	CKD	APPR	REVISION

NAME: P:\02-621-10\Plan\0262110_XS1_sh.dgn 07/11/2014 2:13:37 PM

DRAWN BY ZB DATE 07-07-14
 DESIGN BY MN DATE 07-07-14
 CHECKED BY CAK DATE 07-11-14

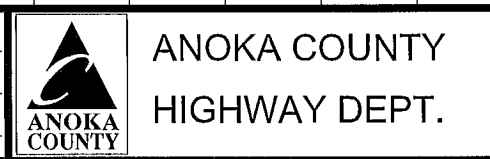

S.A.P. 002-621-010

CROSS SECTIONS
 STA 104+60.00 TO 105+50.00
 Sheet 110 of 147 Sheets

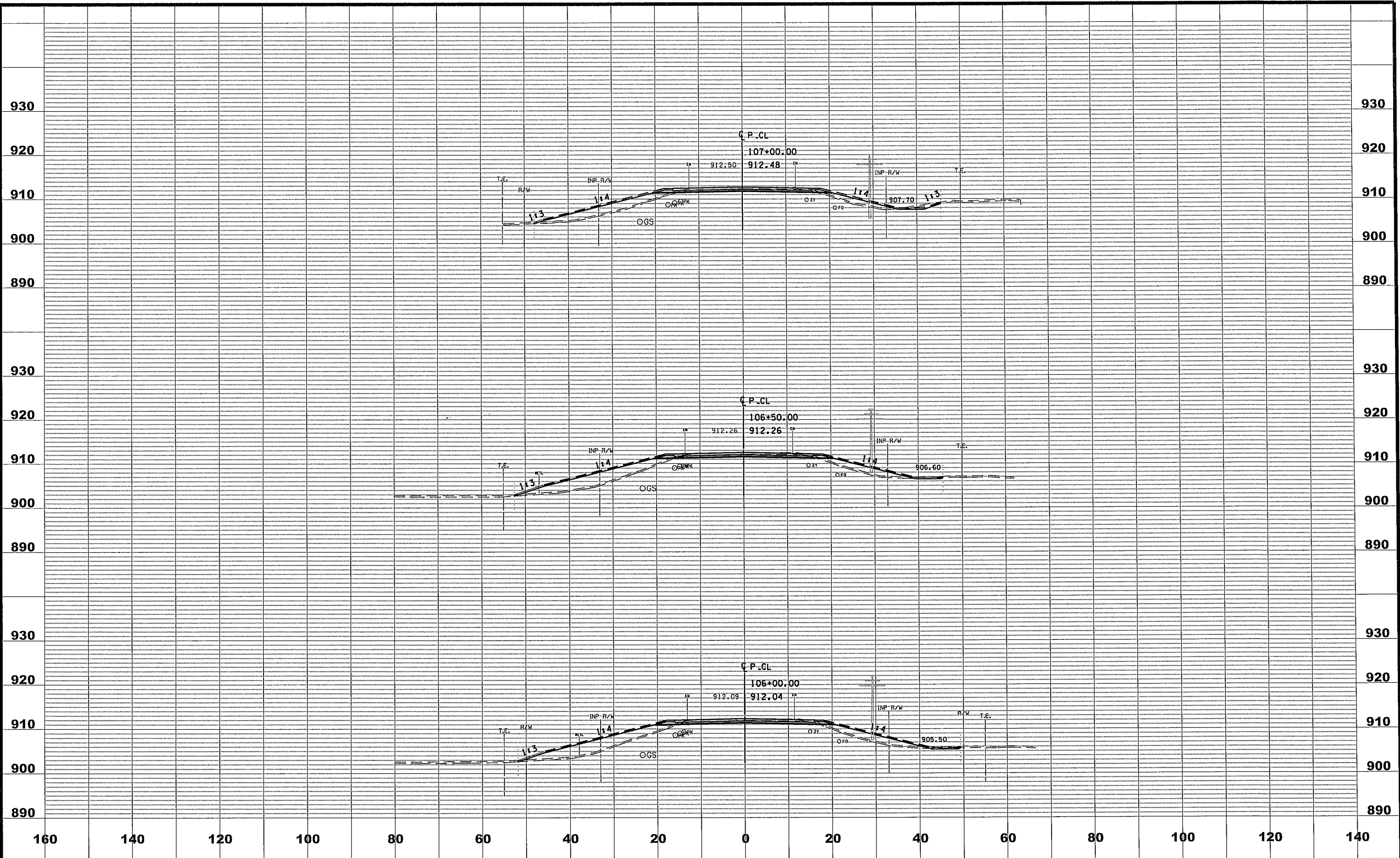

NO	DATE	BY	CKD	APPR	REVISION
NAME: P:\02-621-10\Plan\0262110_XS1_sh.dgn					
07/11/2014 2:13:38 PM					

DRAWN BY ZB DATE 07-07-14
 DESIGN BY MN DATE 07-07-14
 CHECKED BY CAK DATE 07-11-14

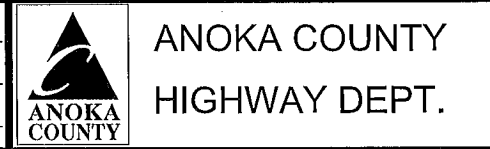

S.A.P. 002-621-010
 STA 106+00.00 TO 107+00.00

CROSS SECTIONS
 Sheet 111 of 147 Sheets

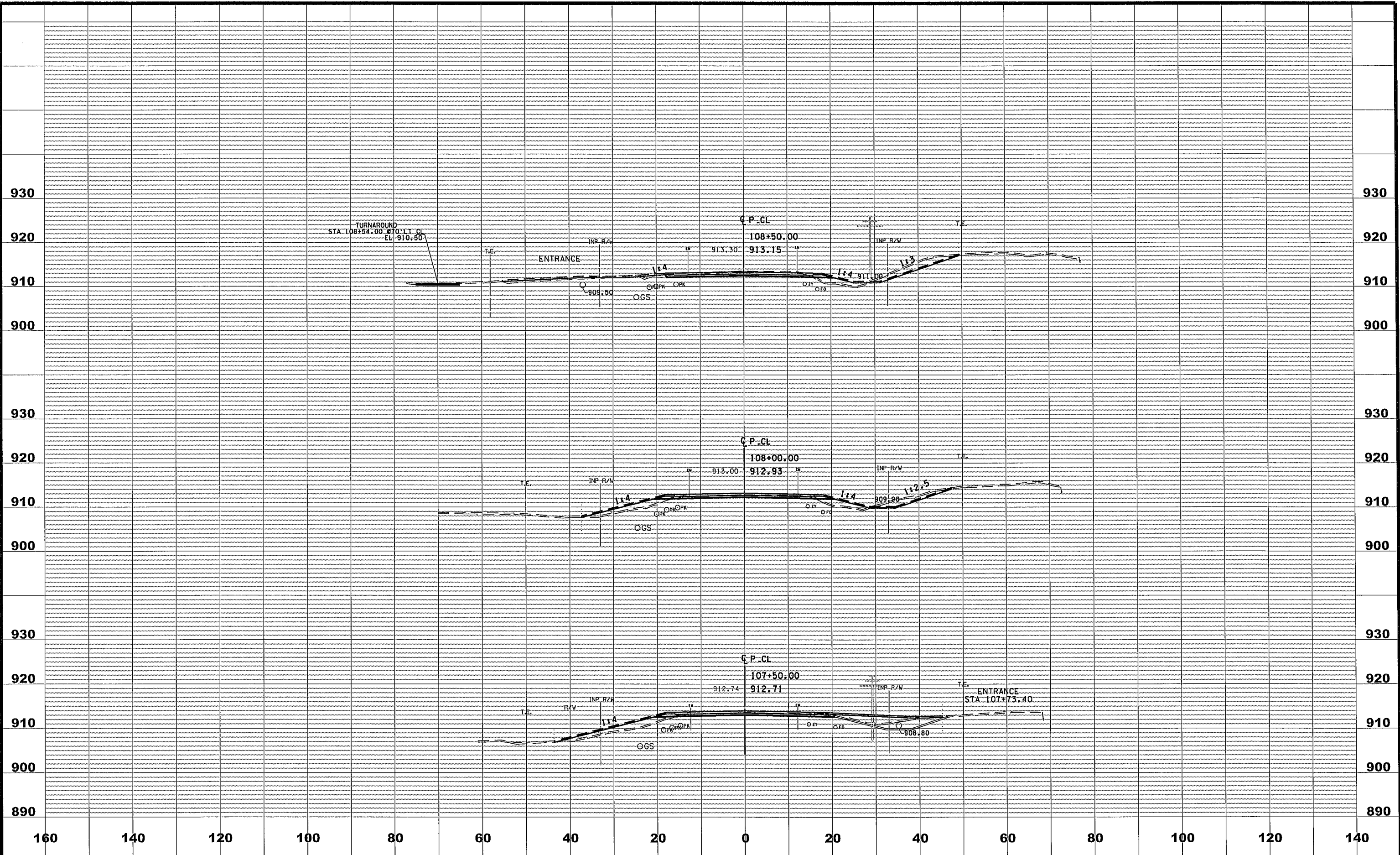

NO	DATE	BY	CKD	APPR	REVISION

NAME: P:\02-621-10\Plan\0262110_XS1_sh.dgn 07/11/2014 2:13:38 PM

DRAWN BY ZB DATE 07-07-14
 DESIGN BY MN DATE 07-07-14
 CHECKED BY CAK DATE 07-11-14

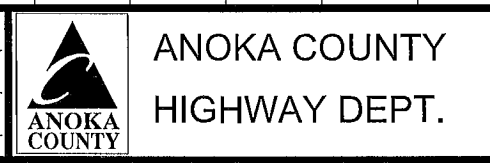

S.A.P. 002-621-010

CROSS SECTIONS
 STA 107+50.00 TO 108+50.00
 Sheet 112 of 147 Sheets

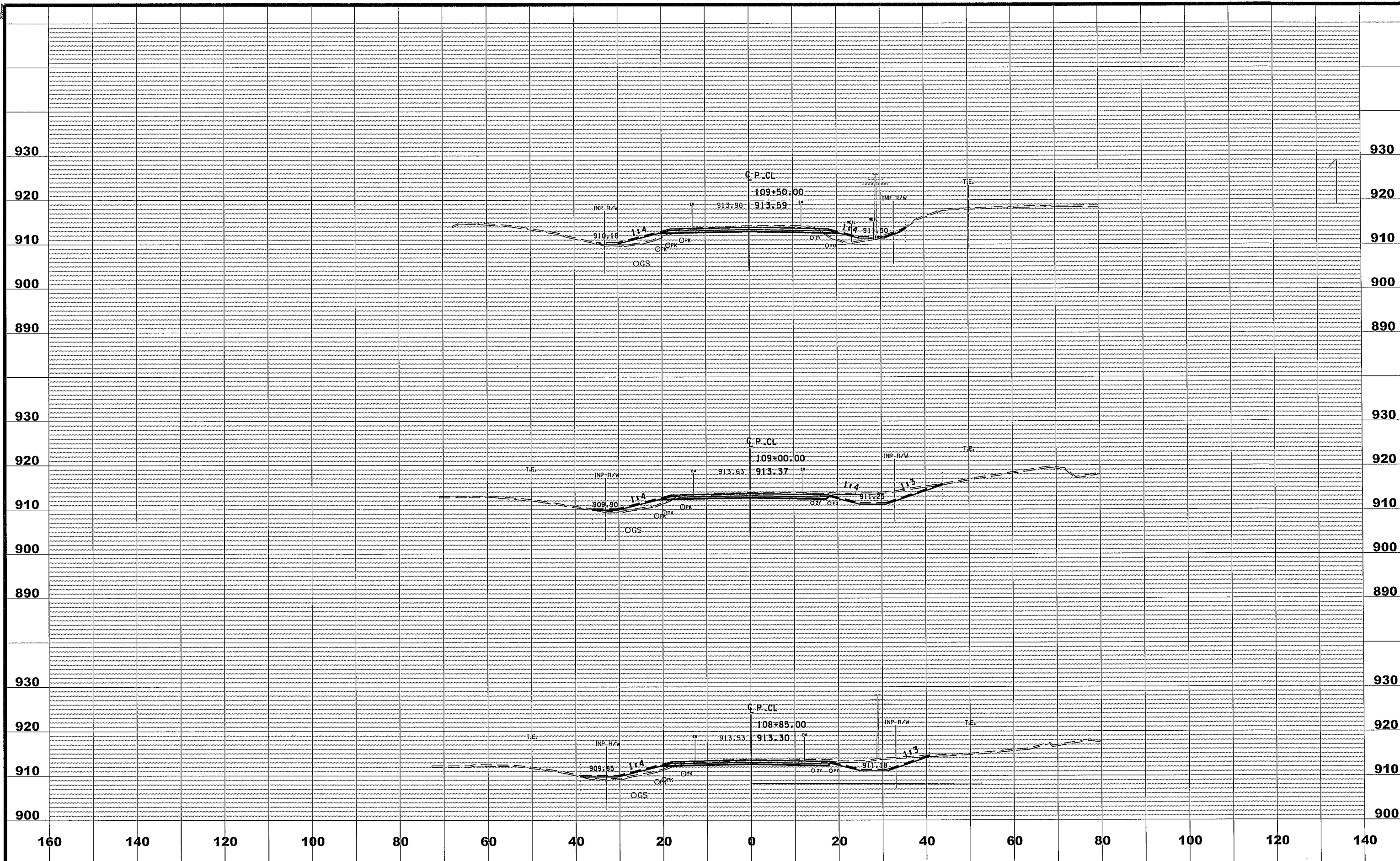

NO	DATE	BY	CKD	APPR	REVISION
NAME: P:\02-621-10\Plan\0262110_XS1_sh.dgn 07/11/2014 2:13:38 PM					

DRAWN BY ZB DATE 07-07-14
 DESIGN BY MN DATE 07-07-14
 CHECKED BY CAK DATE 07-11-14

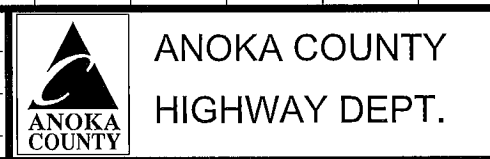

S.A.P. 002-621-010

CROSS SECTIONS
 STA 108+85.00 TO 109+50.00
 Sheet 113 of 147 Sheets

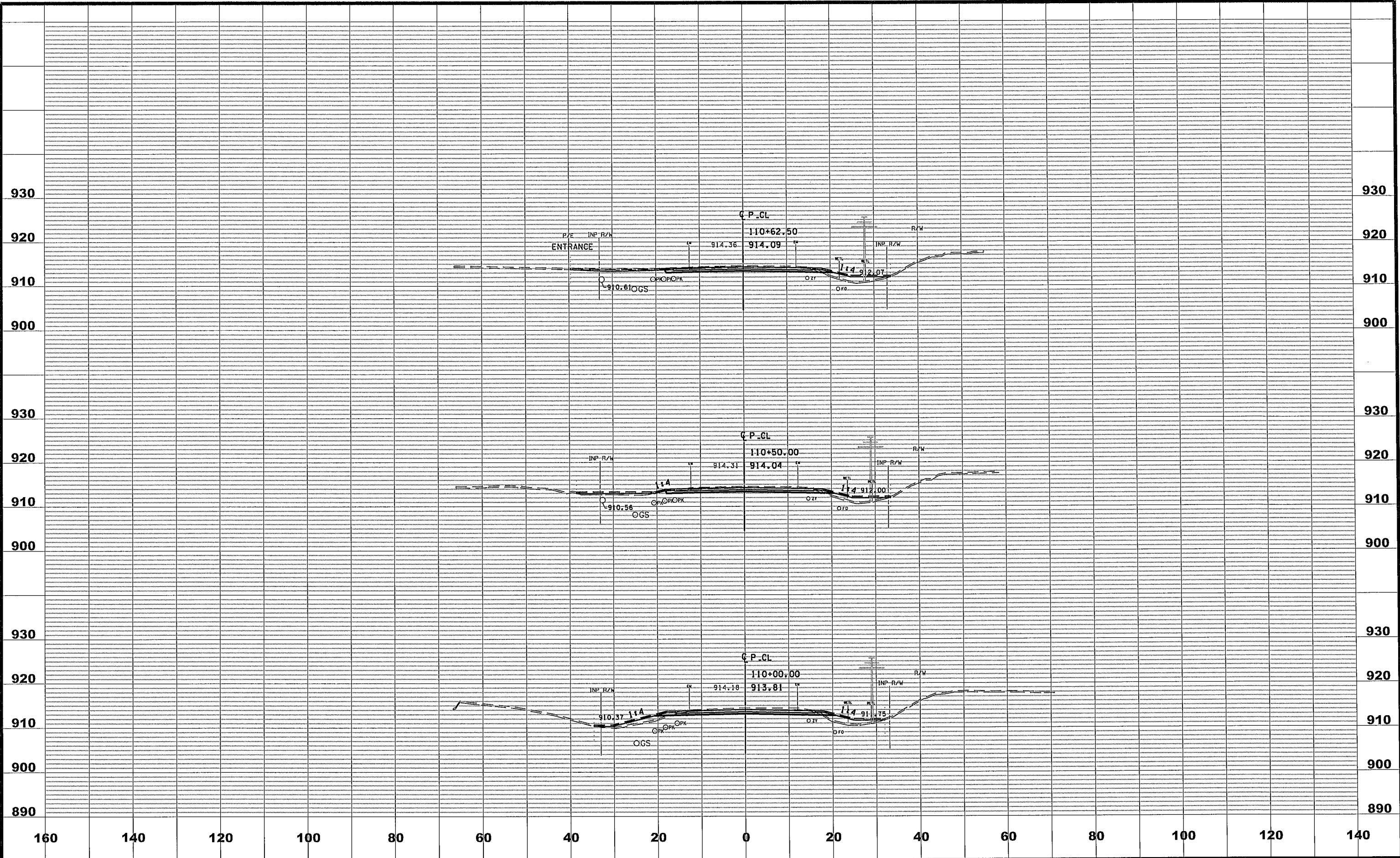

NO	DATE	BY	CKD	APPR	REVISION
NAME: P:\02-621-10\Plan\0262110_XS1_sh.dgn 07/11/2014 2:13:38 PM					

DRAWN BY ZB DATE 07-07-14
 DESIGN BY MN DATE 07-07-14
 CHECKED BY CAK DATE 07-11-14

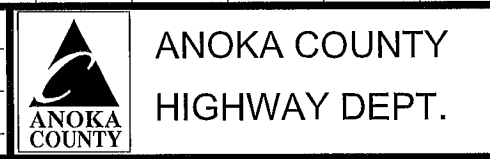

S.A.P. 002-621-010

CROSS SECTIONS
 STA 110+00.00 TO 110+62.50
 Sheet 114 of 147 Sheets

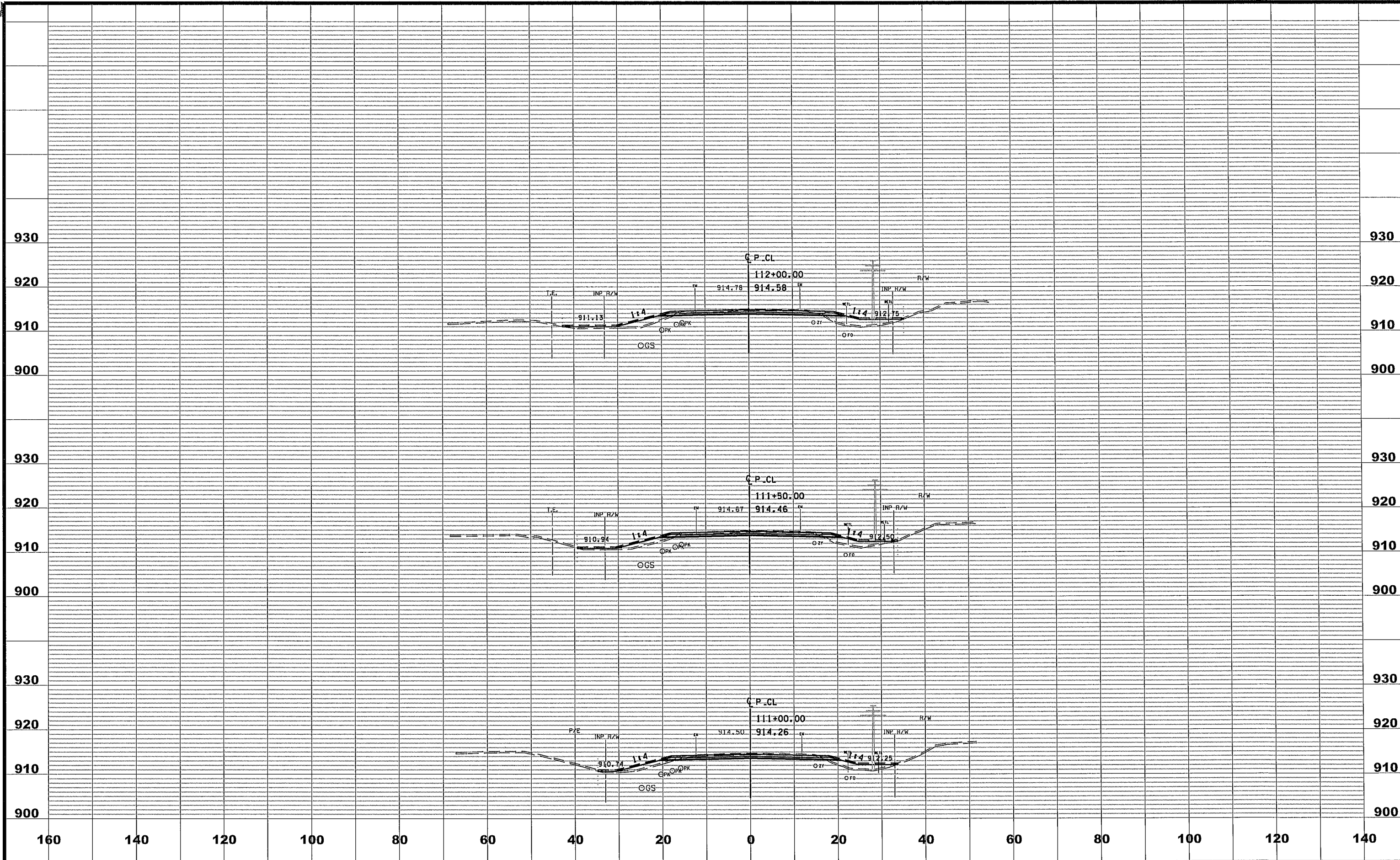

NO	DATE	BY	CKD	APPR	REVISION
NAME: P:\02-621-10\Plan\0262110_XS1_sh.dgn					07/11/2014 2:13:39 PM

DRAWN BY ZB DATE 07-07-14
 DESIGN BY MN DATE 07-07-14
 CHECKED BY CAK DATE 07-11-14

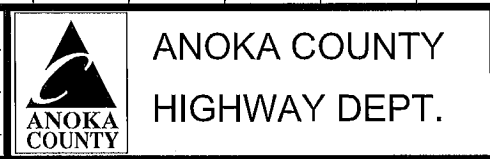

S.A.P. 002-621-010

CROSS SECTIONS
 STA 111+00.00 TO 112+00.00
 Sheet 115 of 147 Sheets

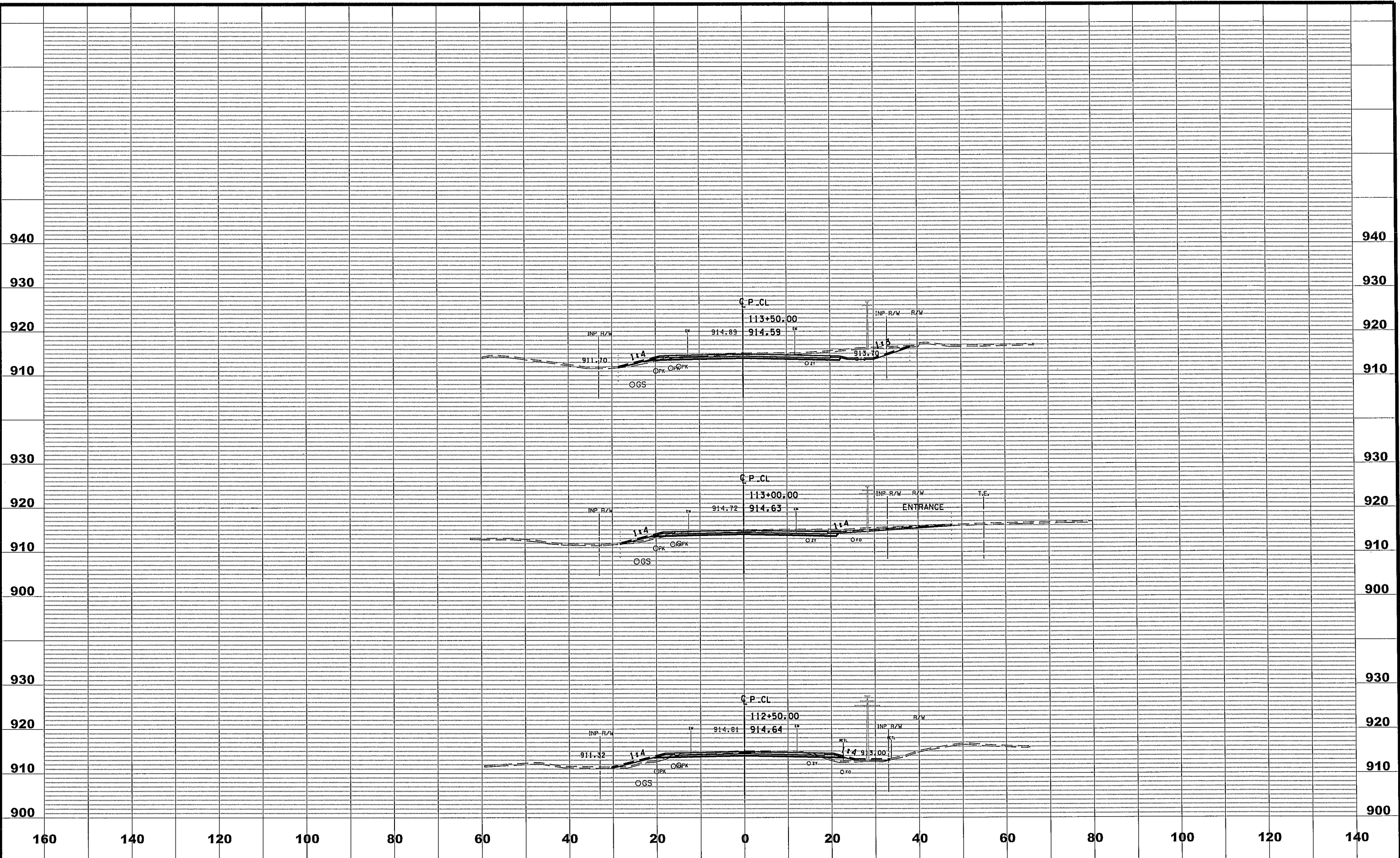

NO	DATE	BY	CKD	APPR	REVISION

NAME: P:\02-621-10\Plan\0262110_XS1_sh.dgn 07/11/2014 2:13:39 PM

DRAWN BY ZB DATE 07-07-14
 DESIGN BY MN DATE 07-07-14
 CHECKED BY CAK DATE 07-11-14

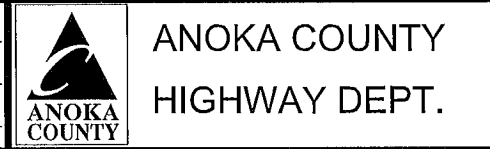

S.A.P. 002-621-010

CROSS SECTIONS
 STA 112+50.00 TO 113+50.00
 Sheet 116 of 147 Sheets

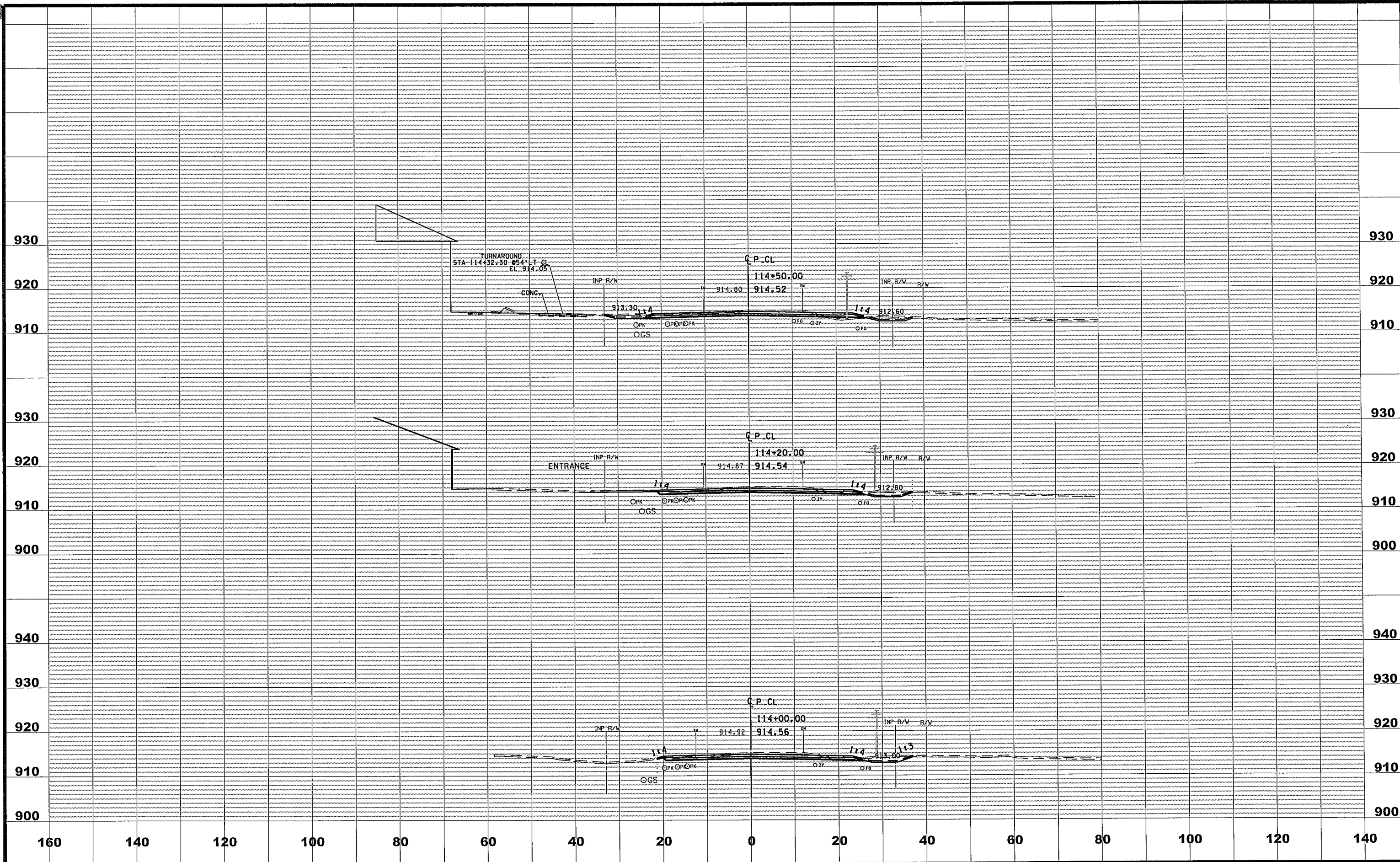

NO	DATE	BY	CKD	APPR	REVISION
NAME: P:\02-621-10\Plan\0262110_XS1_sh.dgn					
07/11/2014 2:13:40 PM					

DRAWN BY ZB DATE 07-07-14
 DESIGN BY MN DATE 07-07-14
 CHECKED BY CAK DATE 07-11-14

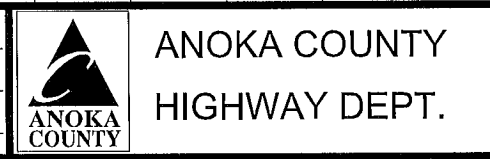

S.A.P. 002-621-010

CROSS SECTIONS
 STA 114+00.00 TO 114+50.00
 Sheet 117 of 147 Sheets

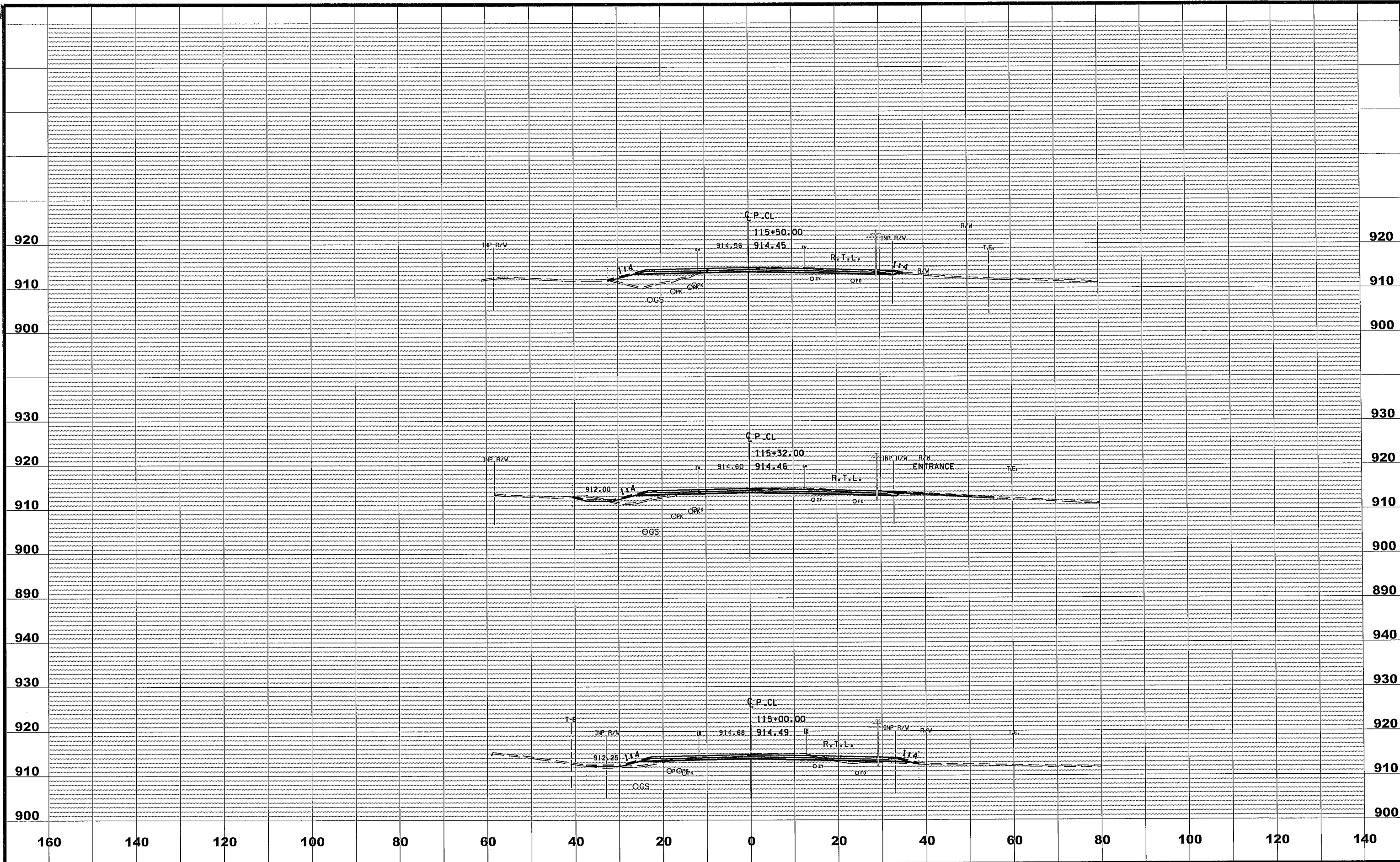

NO	DATE	BY	CKD	APPR	REVISION
NAME: P:\02-621-10\Plan\0262110_XS1_sh.dgn 07/11/2014 2:13:40 PM					

DRAWN BY ZB DATE 07-07-14
 DESIGN BY MN DATE 07-07-14
 CHECKED BY CAK DATE 07-11-14

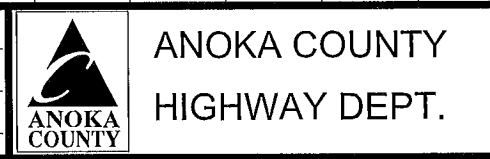

S.A.P. 002-621-010

CROSS SECTIONS
 STA 115+00.00 TO 115+50.00
 Sheet 118 of 147 Sheets

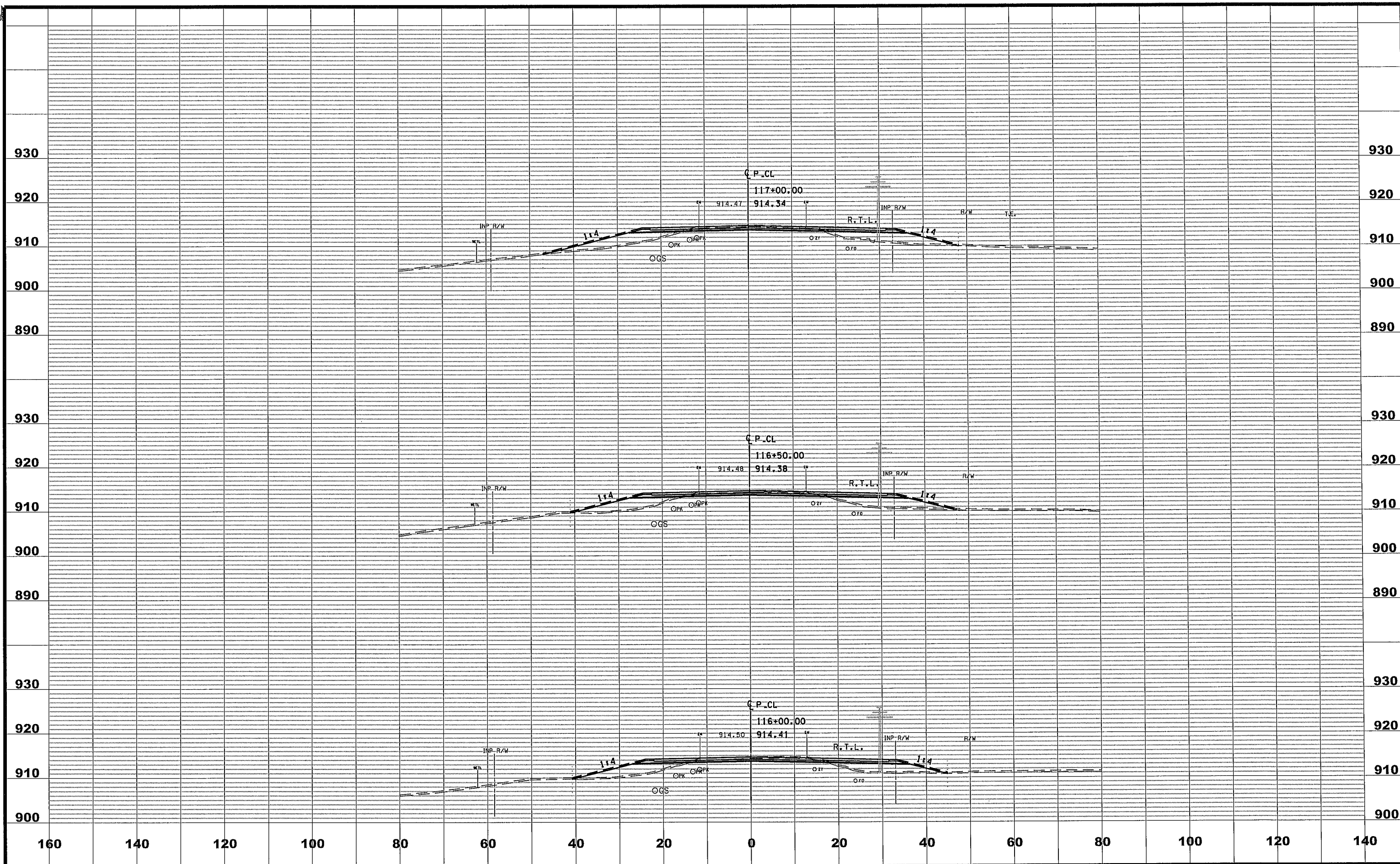

NO	DATE	BY	CKD	APPR	REVISION
NAME: P:\02-621-10\Plan\0262110_XS1_sh.dgn 07/11/2014 2:13:40 PM					

DRAWN BY ZB DATE 07-07-14
 DESIGN BY MN DATE 07-07-14
 CHECKED BY CAK DATE 07-11-14

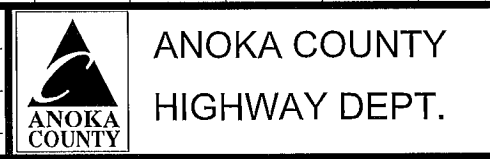

S.A.P. 002-621-010

CROSS SECTIONS
 STA 116+00.00 TO 117+00.00
 Sheet 119 of 147 Sheets

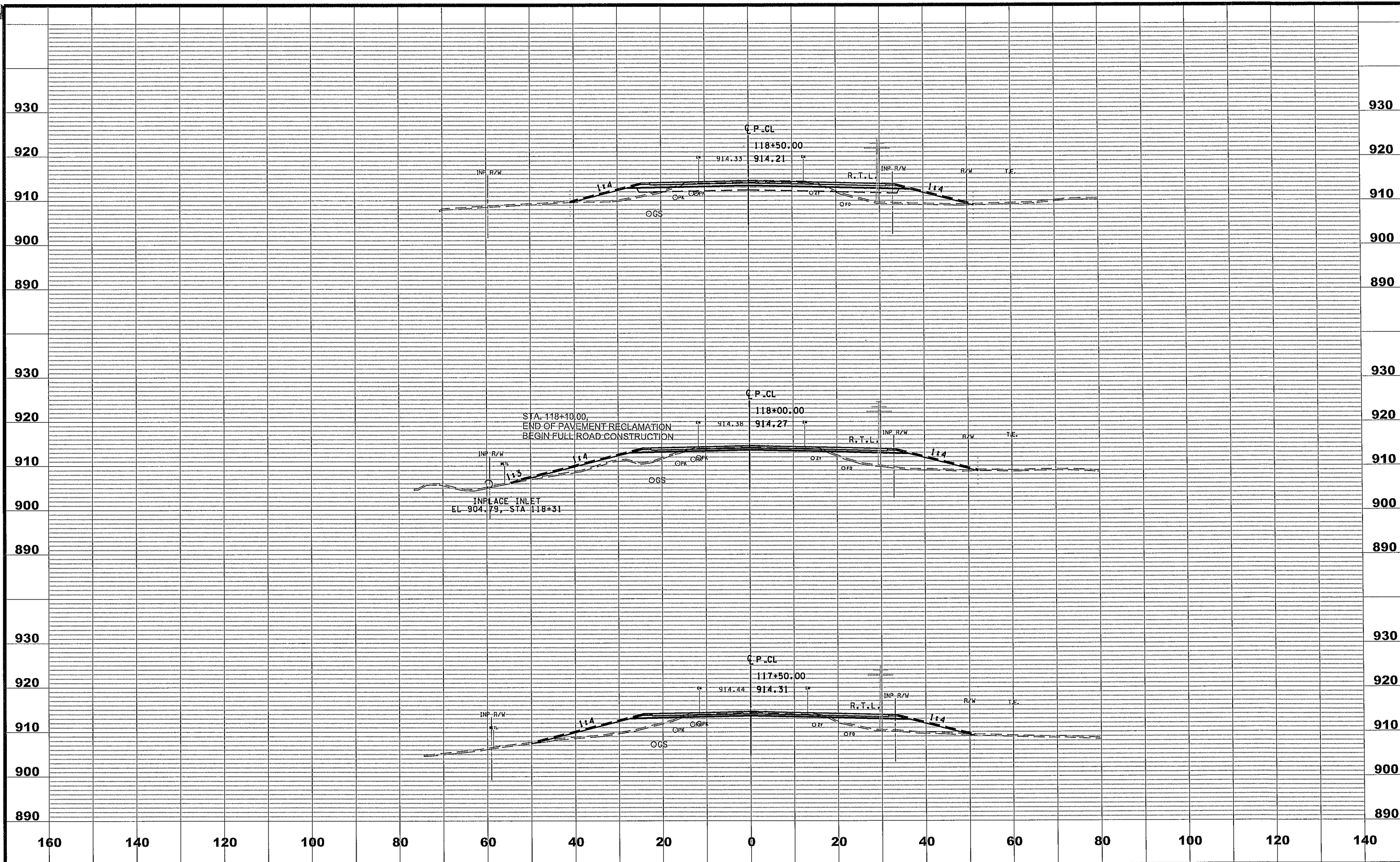

NO	DATE	BY	CKD	APPR	REVISION

NAME: P:\02-621-10\Plan\0262110_XS1_sh.dgn 07/11/2014 2:13:41 PM

DRAWN BY ZB DATE 07-07-14
 DESIGN BY MN DATE 07-07-14
 CHECKED BY CAK DATE 07-11-14

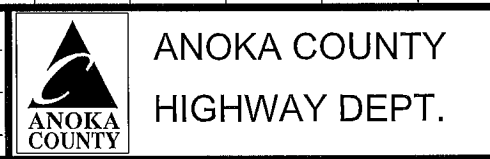

S.A.P. 002-621-010

CROSS SECTIONS
 STA 117+50.00 TO 118+50.00
 Sheet 120 of 147 Sheets

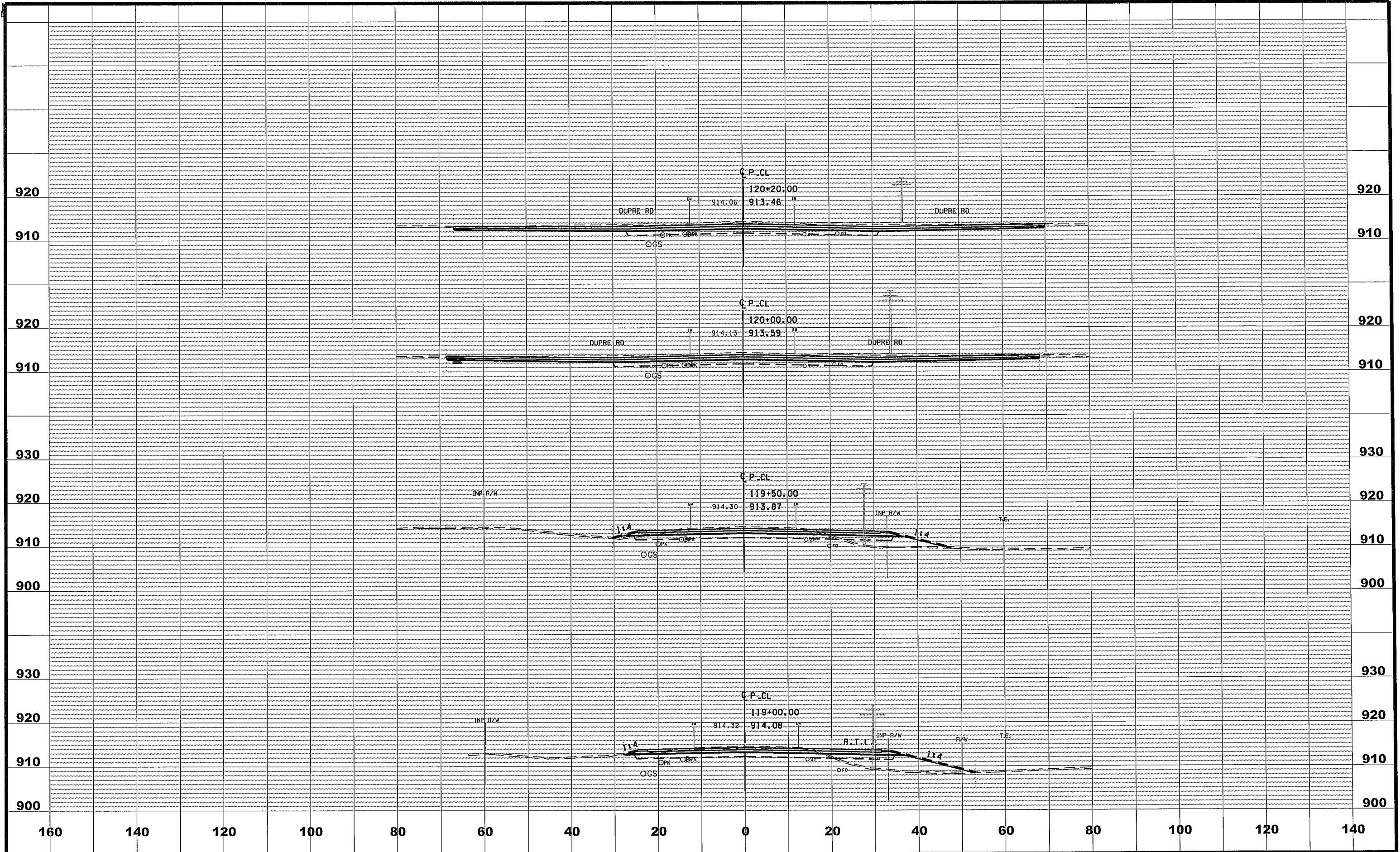

NO	DATE	BY	CKD	APPR	REVISION

NAME: P:\02-621-10\Plan\0262110_XS1_sh.dgn 07/11/2014 2:13:41 PM

DRAWN BY ZB DATE 07-07-14
 DESIGN BY MN DATE 07-07-14
 CHECKED BY CAK DATE 07-11-14

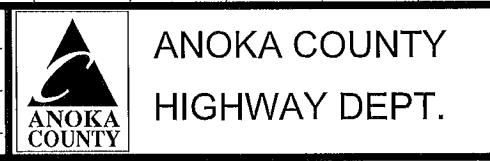

S.A.P. 002-621-010

CROSS SECTIONS
 STA 119+00.00 TO 120+20.00
 Sheet 121 of 147 Sheets

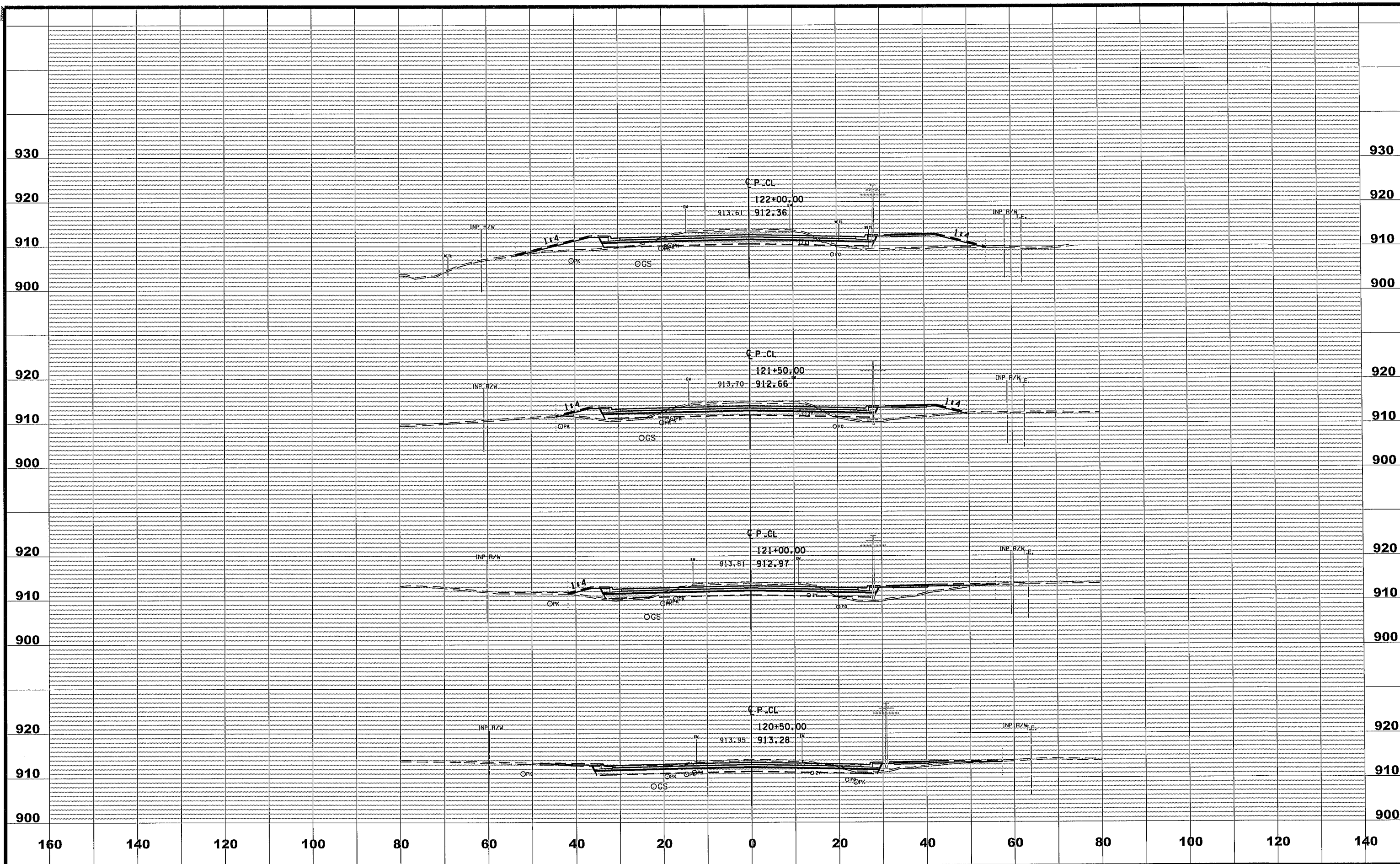

NO	DATE	BY	CKD	APPR	REVISION
NAME: P:\02-621-10\Plan\0262110_XS1_sh.dgn 07/11/2014 2:13:41 PM					

DRAWN BY ZB DATE 07-07-14
 DESIGN BY MN DATE 07-07-14
 CHECKED BY CAK DATE 07-11-14

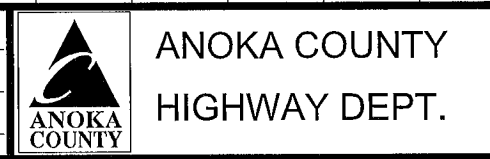

S.A.P. 002-621-010

CROSS SECTIONS
 STA 120+50.00 TO 122+00.02
 Sheet 122 of 147 Sheets

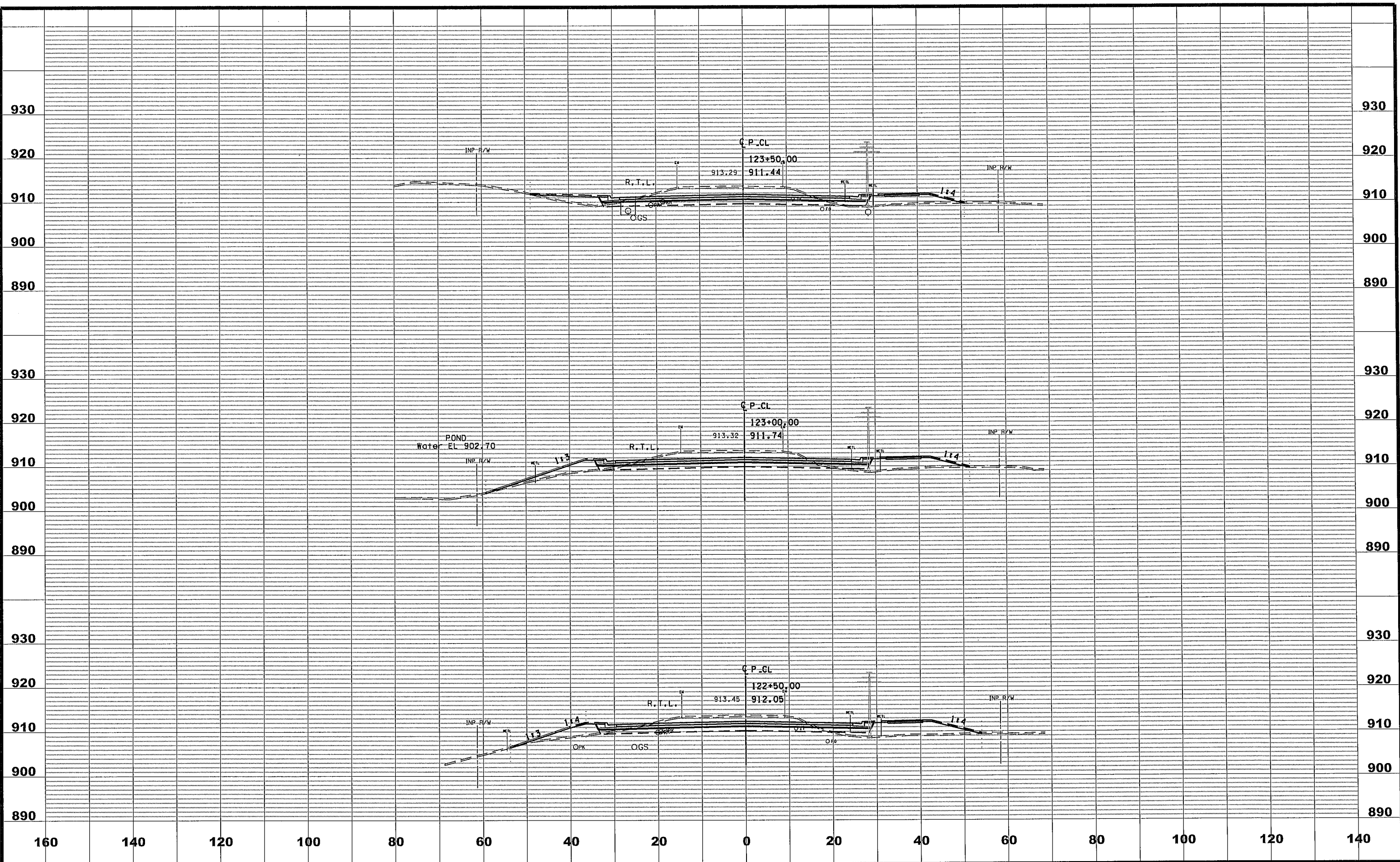

NO	DATE	BY	CKD	APPR	REVISION
NAME: P:\02-621-10\Plan\0262110_XS1_sh.dgn					
07/11/2014 2:13:42 PM					

DRAWN BY <u>ZB</u> DATE <u>07-07-14</u> DESIGN BY <u>MN</u> DATE <u>07-07-14</u> CHECKED BY <u>CAK</u> DATE <u>07-11-14</u>

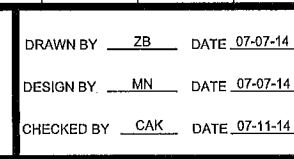

ANOKA COUNTY
HIGHWAY DEPT.

S.A.P. 002-621-010

CROSS SECTIONS
STA 122+50.02 TO 123+50.02
Sheet 123 of 147 Sheets

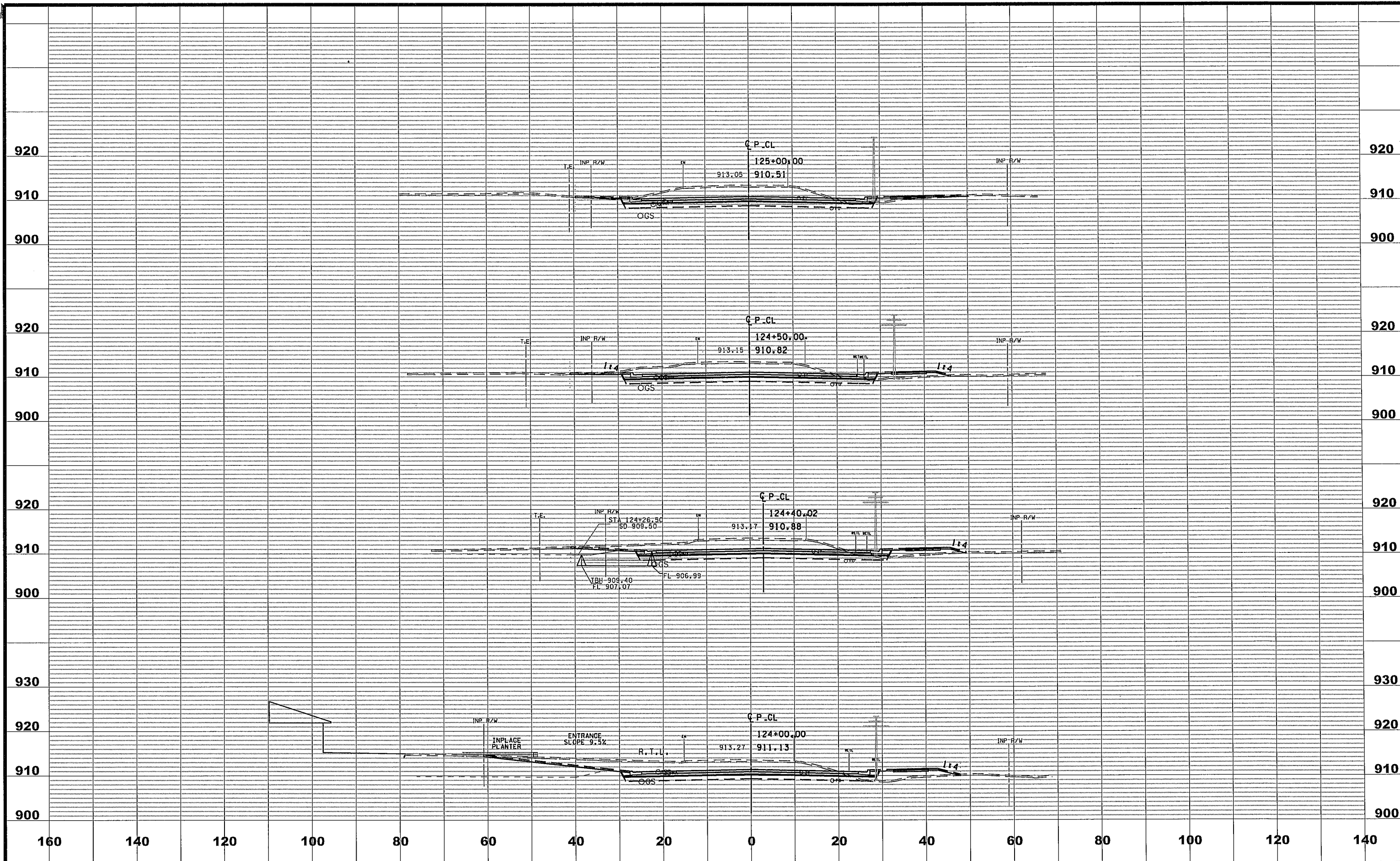

NO	DATE	BY	CKD	APPR	REVISION
NAME: P:\02-621-10\Plan\0262110_XS1_sh.dgn					
07/11/2014 2:13:42 PM					

DRAWN BY ZB DATE 07-07-14
 DESIGN BY MN DATE 07-07-14
 CHECKED BY CAK DATE 07-11-14

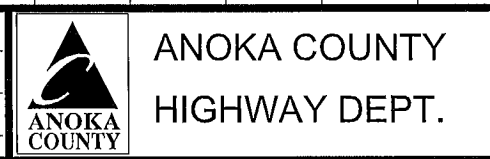

S.A.P. 002-621-010

CROSS SECTIONS
 STA 124+00.02 TO 125+00.02
 Sheet 124 of 147 Sheets

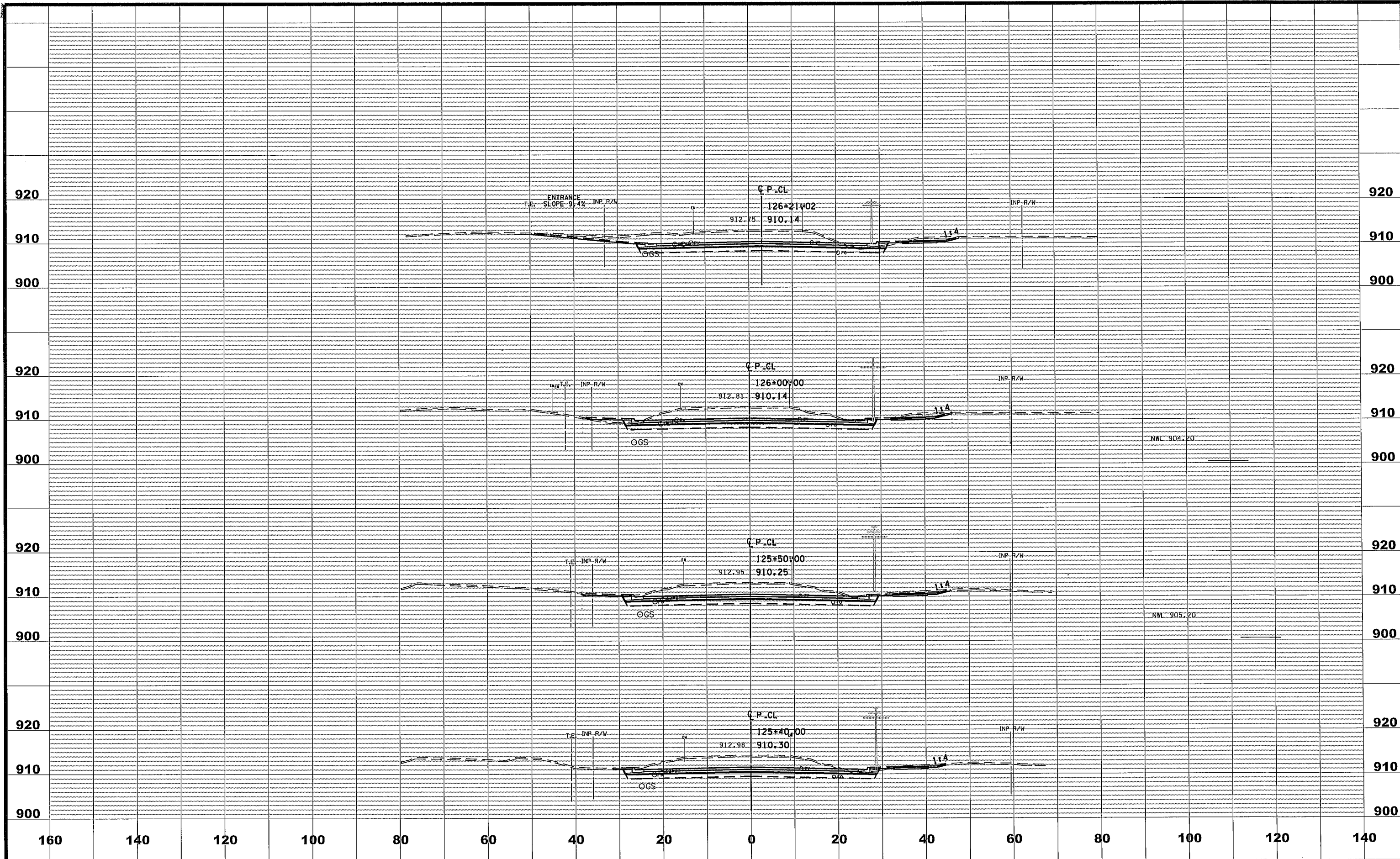

NO	DATE	BY	CKD	APPR	REVISION

NAME: P:\02-621-10\Plan\0262110_XS1_sh.dgn 07/11/2014 2:13:42 PM

DRAWN BY ZB DATE 07-07-14
 DESIGN BY MN DATE 07-07-14
 CHECKED BY CAK DATE 07-11-14

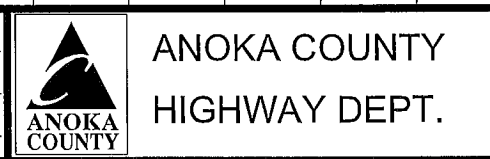

S.A.P. 002-621-010

CROSS SECTIONS
 STA 125+46.02 TO 126+21.02
 Sheet 125 of 147 Sheets

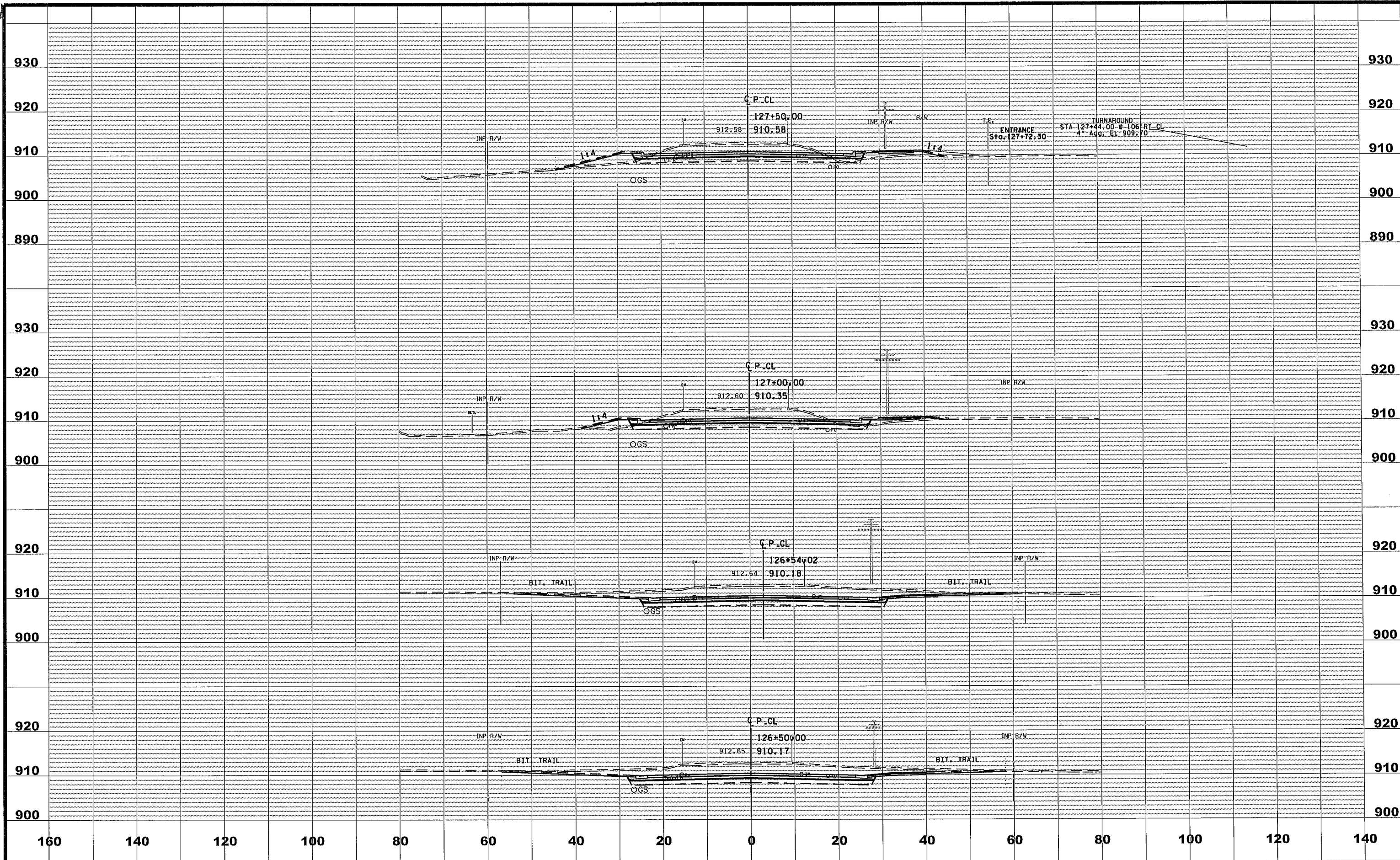

NO	DATE	BY	CKD	APPR	REVISION

NAME: P:\02-621-10\Plan\0262110_XS1_sh.dgn 07/11/2014 2:13:43 PM

DRAWN BY ZB DATE 07-07-14
 DESIGN BY MN DATE 07-07-14
 CHECKED BY CAK DATE 07-11-14

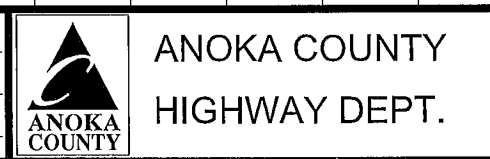

S.A.P. 002-621-010

CROSS SECTIONS
 STA 126+50.02 TO 127+50.02
 Sheet 126 of 147 Sheets

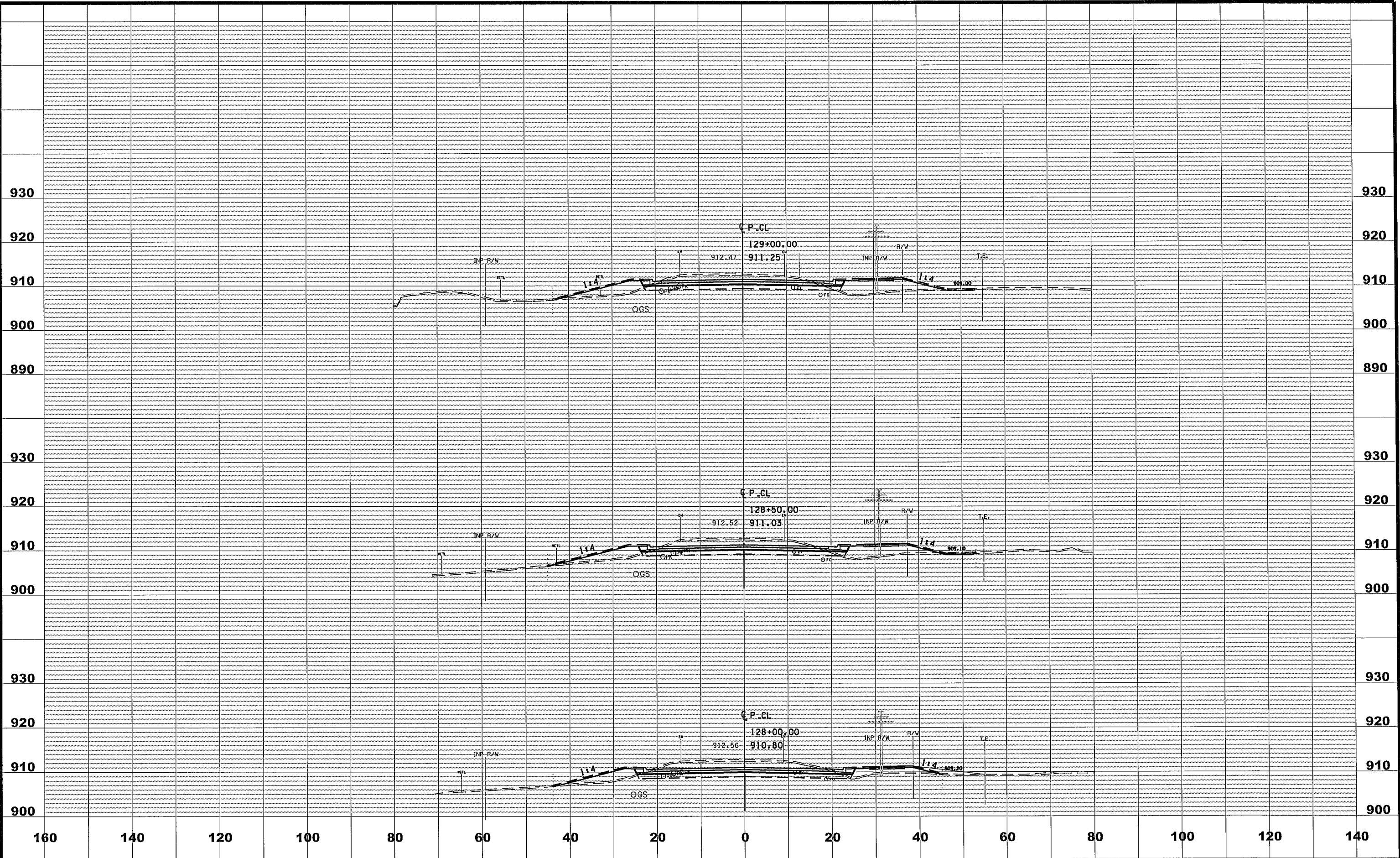

NO	DATE	BY	CKD	APPR	REVISION
NAME: P:\02-621-10\Plan\0262110_XS1_sh.dgn					
07/11/2014 2:13:43 PM					

DRAWN BY ZB DATE 07-07-14
 DESIGN BY MN DATE 07-07-14
 CHECKED BY CAK DATE 07-11-14

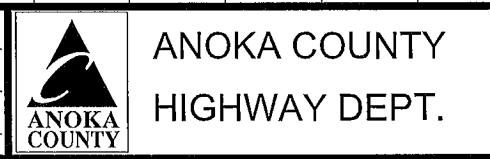

S.A.P. 002-621-010

CROSS SECTIONS
 STA 128+00.02 TO 129+00.02
 Sheet 127 of 147 Sheets

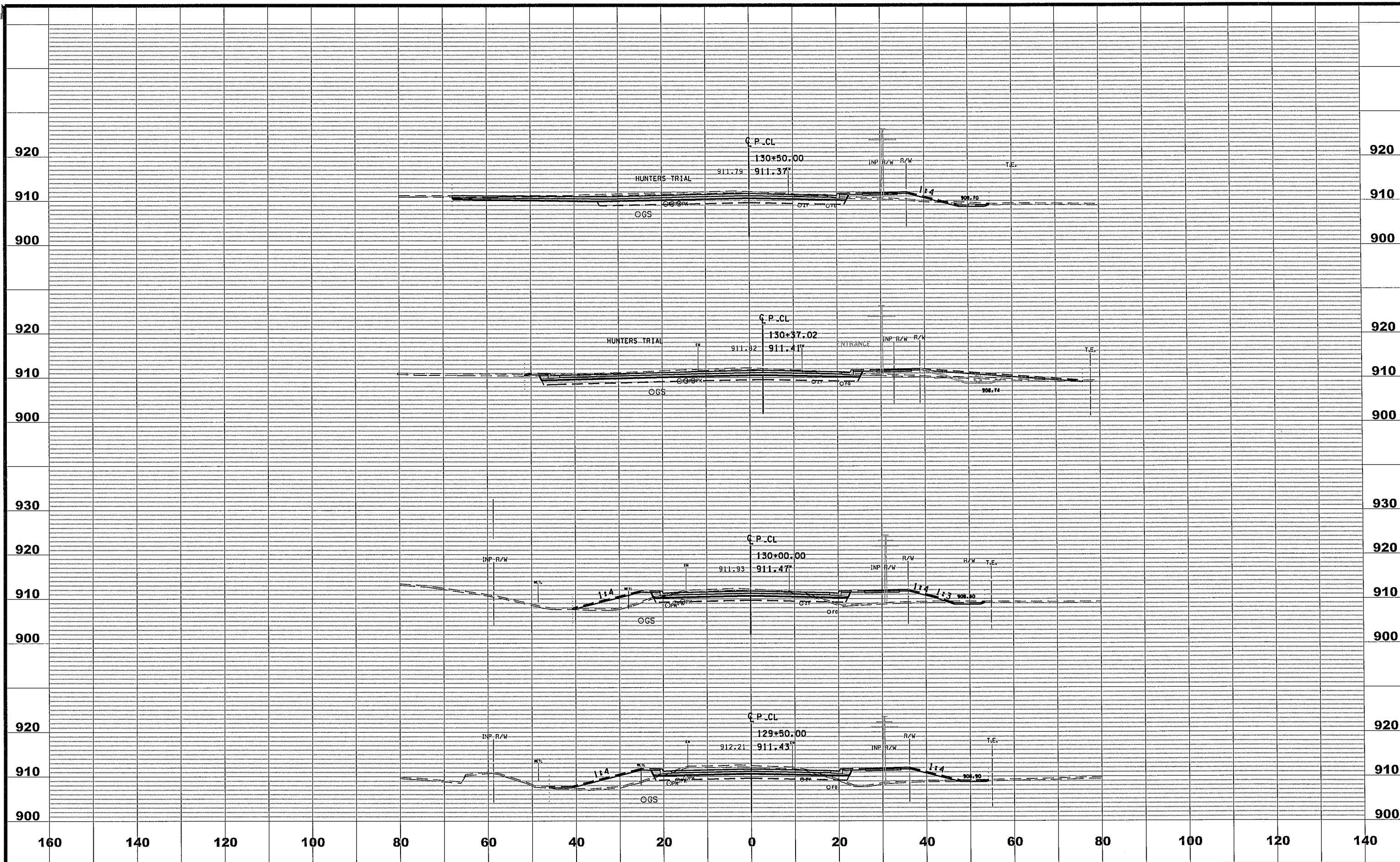

NO	DATE	BY	CKD	APPR	REVISION
NAME: P:\02-621-10\Plan\0262110_XS1_sh.dgn					
07/11/2014 2:13:43 PM					

DRAWN BY ZB DATE 07-07-14
 DESIGN BY MN DATE 07-07-14
 CHECKED BY CAK DATE 07-11-14

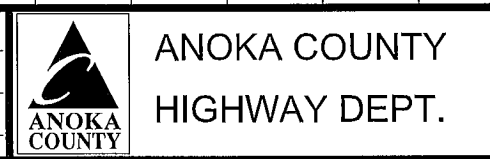

S.A.P. 002-621-010
 CROSS SECTIONS
 STA 129+50.02 TO 130+50.02
 Sheet 128 of 147 Sheets

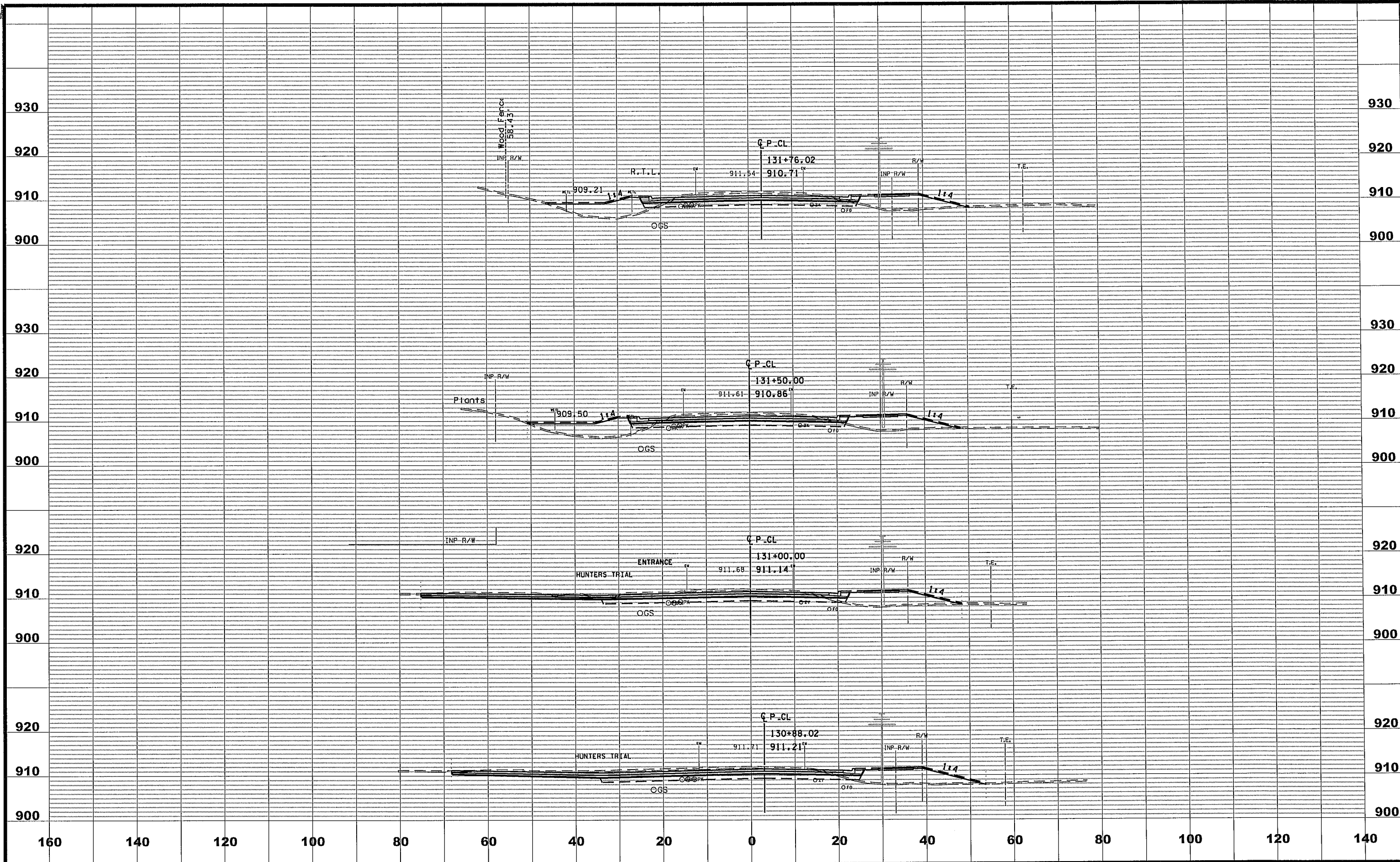

NO	DATE	BY	CKD	APPR	REVISION
NAME: P:\02-621-10\Plan\0262110_XS1_sh.dgn					
07/11/2014 2:13:44 PM					

DRAWN BY ZB DATE 07-07-14
 DESIGN BY MN DATE 07-07-14
 CHECKED BY CAK DATE 07-11-14

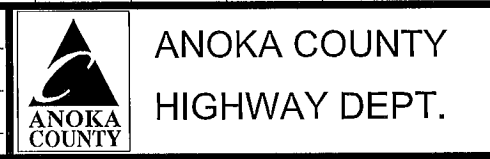

S.A.P. 002-621-010

CROSS SECTIONS
 STA 130+88.02 TO 131+76.02
 Sheet 129 of 147 Sheets

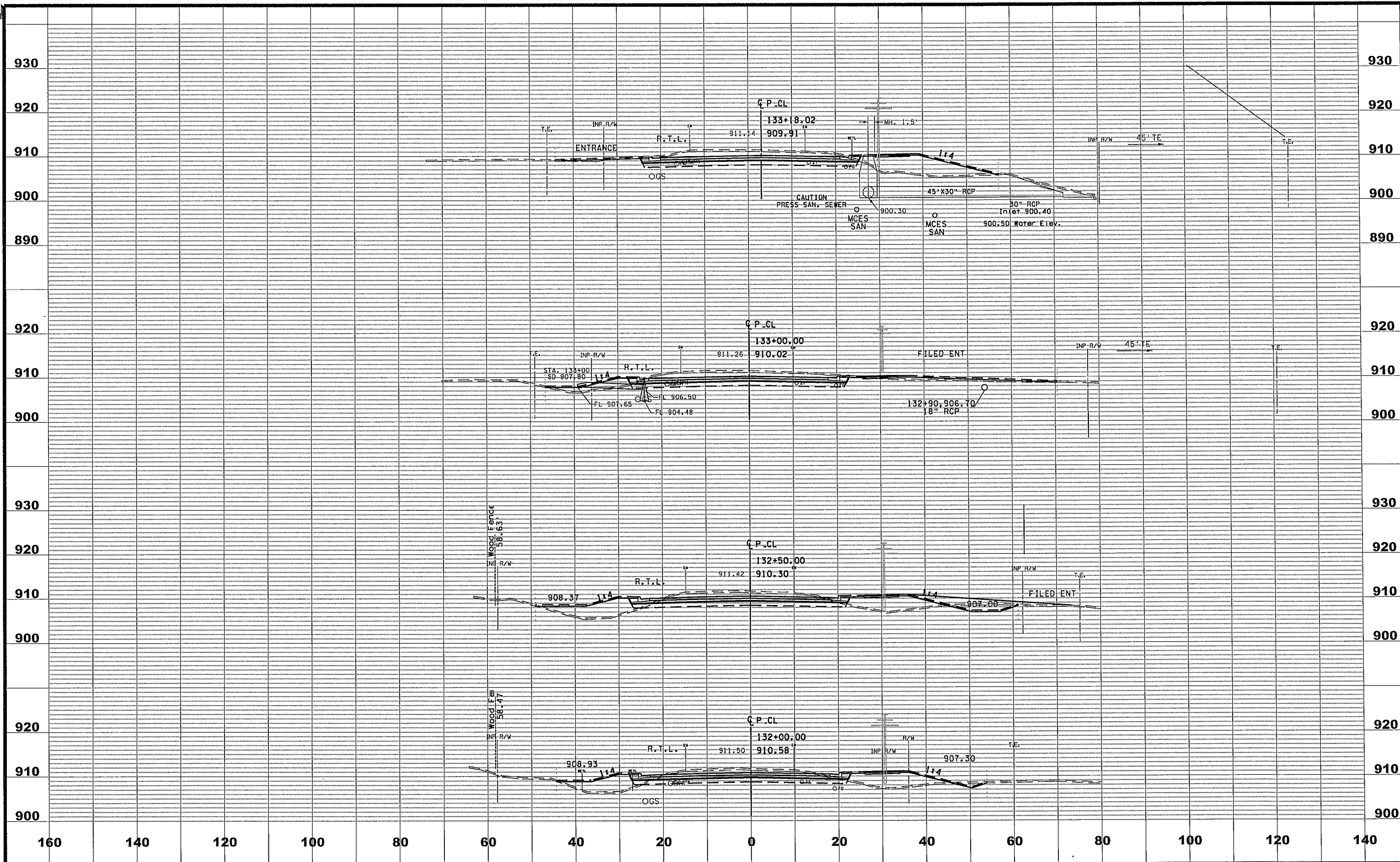

NO	DATE	BY	CKD	APPR	REVISION
NAME: P:\02-621-10\Plan\0262110_XS1_sh.dgn					
07/11/2014 2:13:44 PM					

DRAWN BY ZB DATE 07-07-14
 DESIGN BY MN DATE 07-07-14
 CHECKED BY CAK DATE 07-11-14

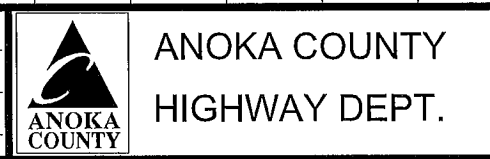

S.A.P. 002-621-010

CROSS SECTIONS
 STA 132+00.02 TO 133+18.02
 Sheet 130 of 147 Sheets

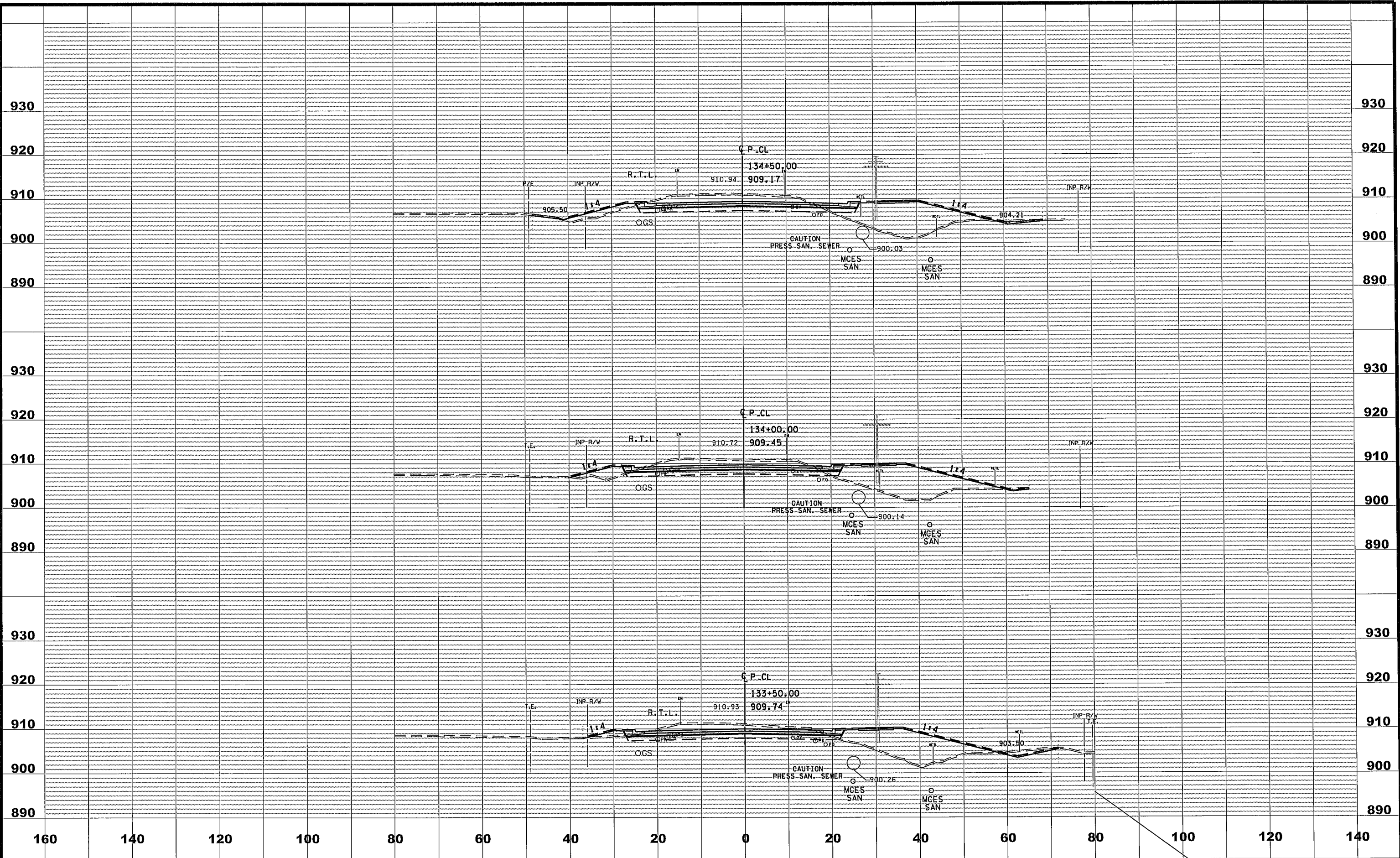

NO	DATE	BY	CKD	APPR	REVISION

NAME: P:\02-621-10\Plan\0262110_XS1_sh.dgn 07/11/2014 2:13:44 PM

DRAWN BY ZB DATE 07-07-14
 DESIGN BY MN DATE 07-07-14
 CHECKED BY CAK DATE 07-11-14

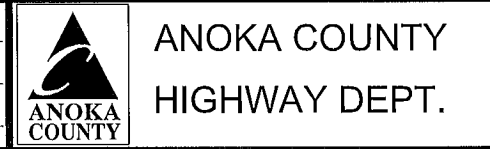

S.A.P. 002-621-010

CROSS SECTIONS
 STA 133+50.02 TO 134+50.02
 Sheet 131 of 147 Sheets

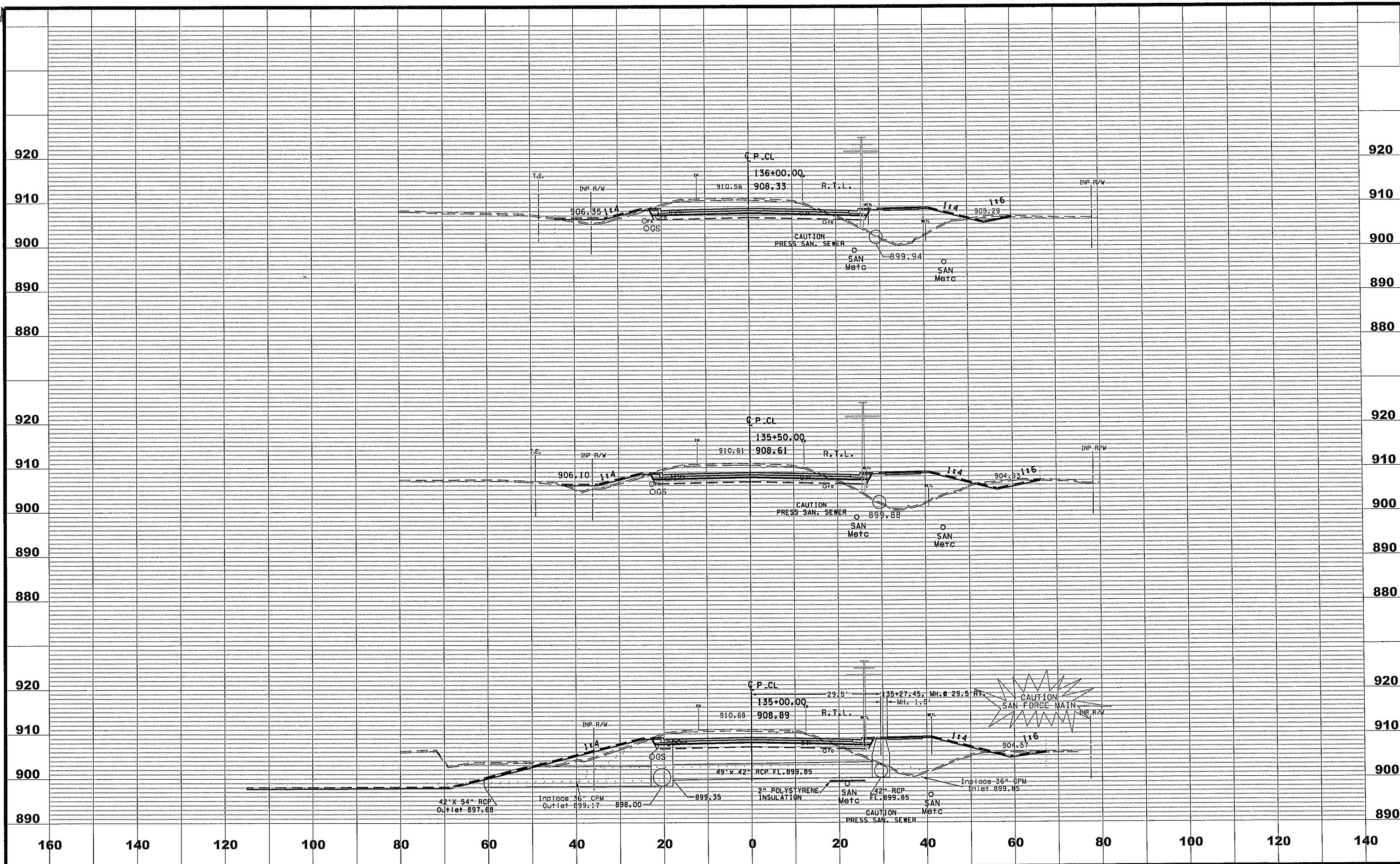

NO	DATE	BY	CKD	APPR	REVISION

NAME: P:\02-621-10\Plan\0262110_XS1_sh.dgn 07/11/2014 2:13:45 PM

DRAWN BY ZB DATE 07-07-14
 DESIGN BY MN DATE 07-07-14
 CHECKED BY CAK DATE 07-11-14

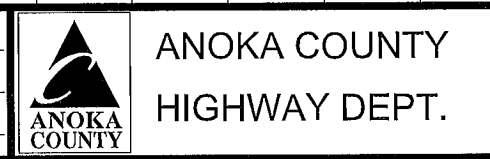

S.A.P. 002-621-010

CROSS SECTIONS
 STA 135+00.02 TO 136+00.02
 Sheet 132 of 147 Sheets

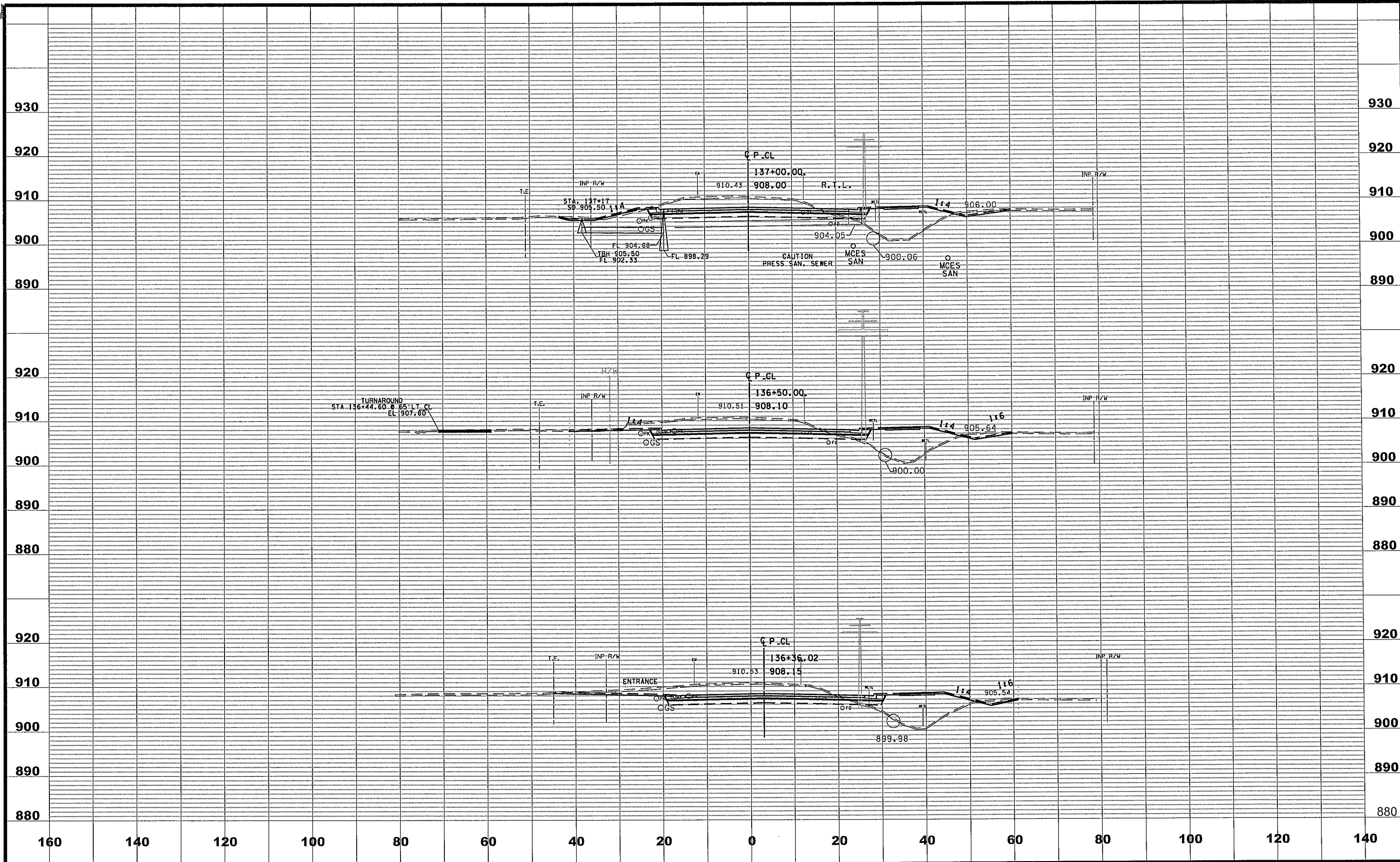

NO	DATE	BY	CKD	APPR	REVISION
NAME: P:\02-621-10\Plan\0262110_XS1_sh.dgn 07/11/2014 2:13:45 PM					

DRAWN BY ZB DATE 07-07-14
 DESIGN BY MN DATE 07-07-14
 CHECKED BY CAK DATE 07-11-14

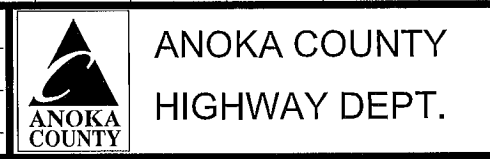

S.A.P. 002-621-010

CROSS SECTIONS
 STA 136+36.02 TO 137+00.02
 Sheet 133 of 147 Sheets

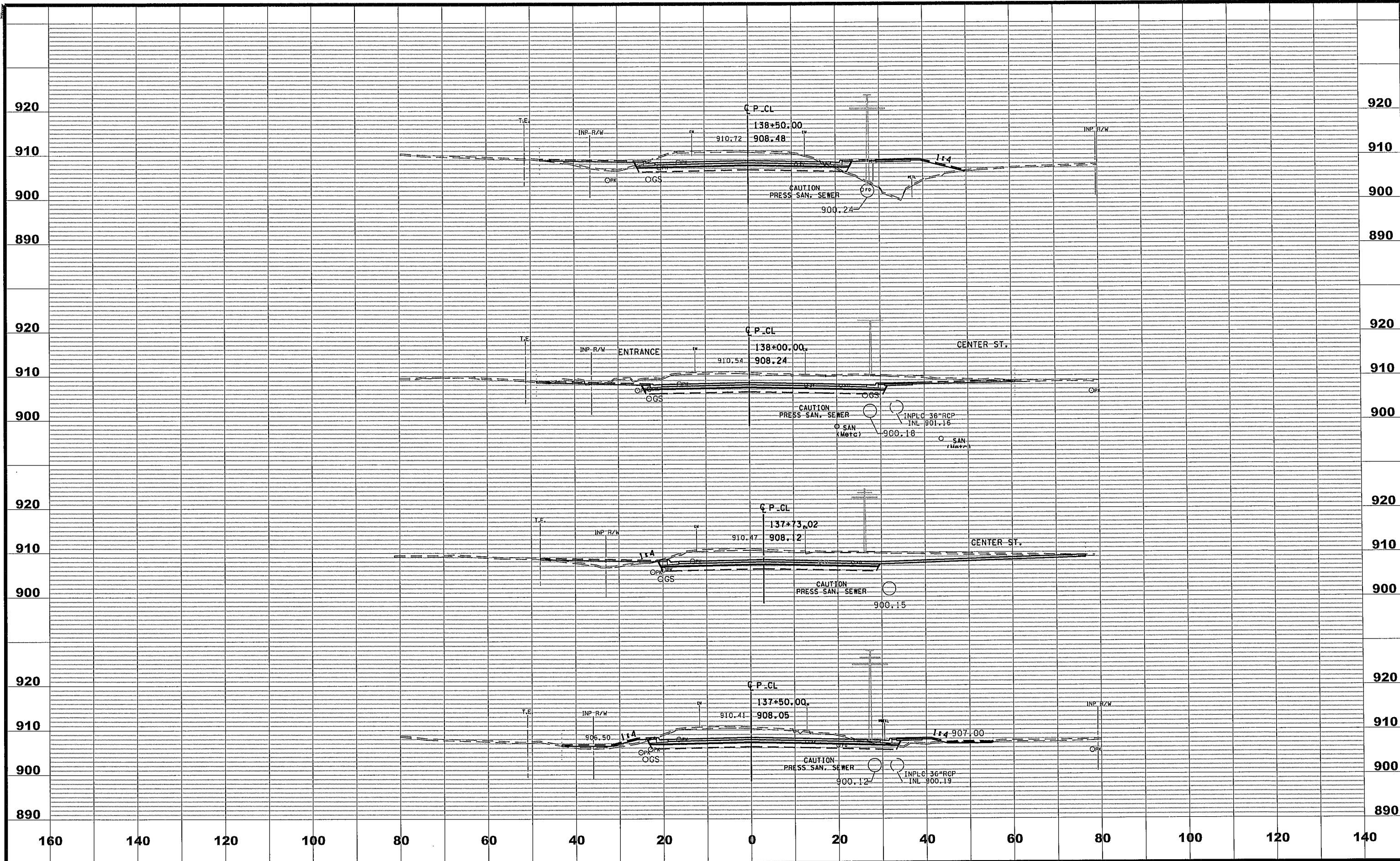

NO	DATE	BY	CKD	APPR	REVISION

NAME: P:\02-621-10\Plan\0262110_XS1_sh.dgn 07/11/2014 2:13:45 PM

DRAWN BY ZB DATE 07-07-14
 DESIGN BY MN DATE 07-07-14
 CHECKED BY CAK DATE 07-11-14

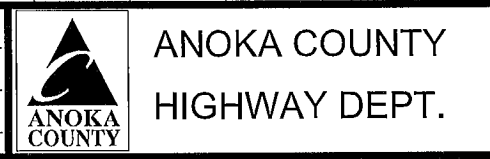

S.A.P. 002-621-010

CROSS SECTIONS
 STA 137+50.02 TO 138+50.02
 Sheet 134 of 147 Sheets

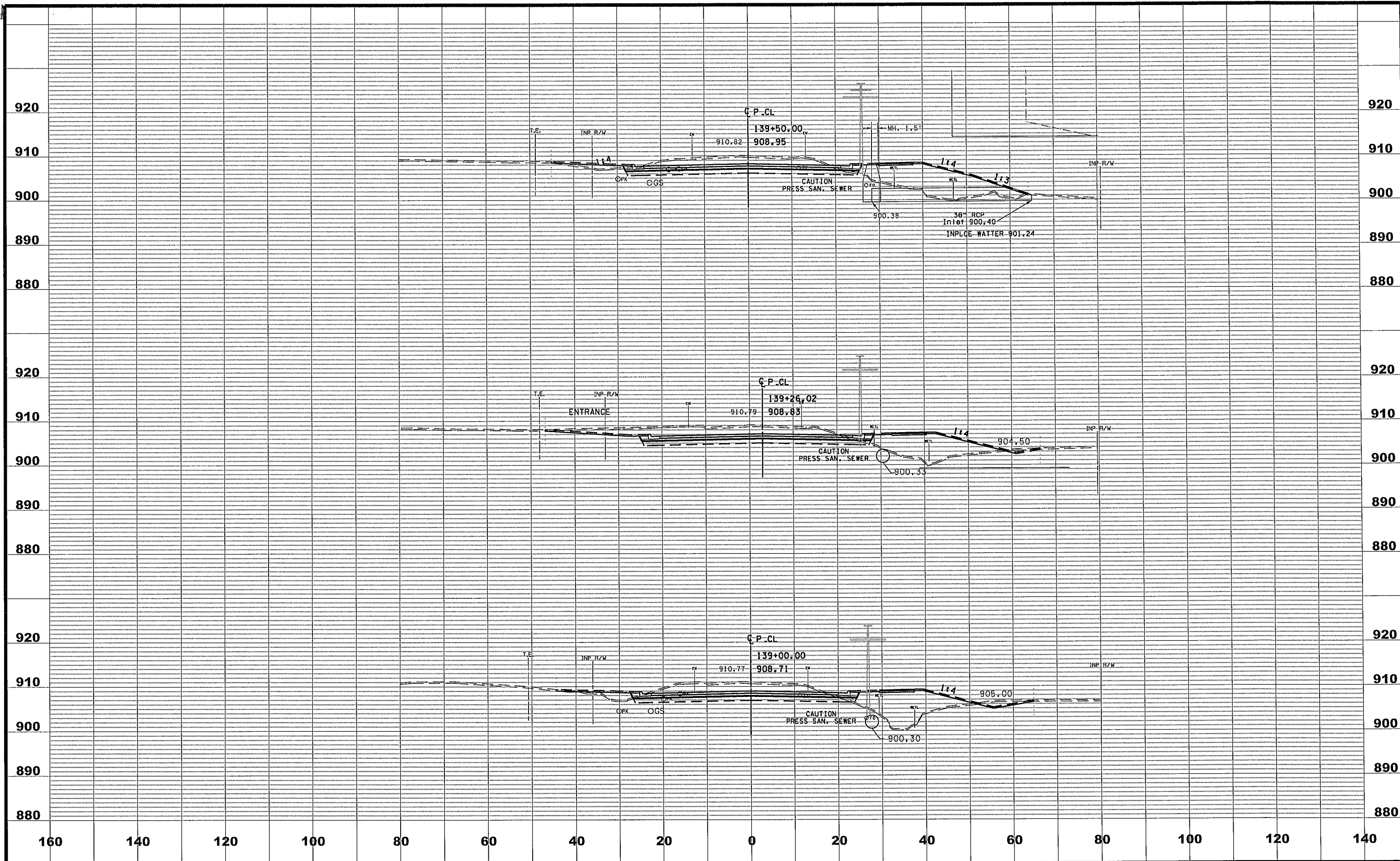

NO	DATE	BY	CKD	APPR	REVISION
NAME: P:\02-621-10\Plan\0262110_XS1_sh.dgn 07/11/2014 2:13:46 PM					

DRAWN BY ZB DATE 07-07-14
 DESIGN BY MN DATE 07-07-14
 CHECKED BY CAK DATE 07-11-14

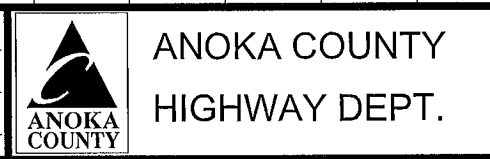

S.A.P. 002-621-010

CROSS SECTIONS
 STA 139+00.02 TO 139+50.03
 Sheet 135 of 147 Sheets

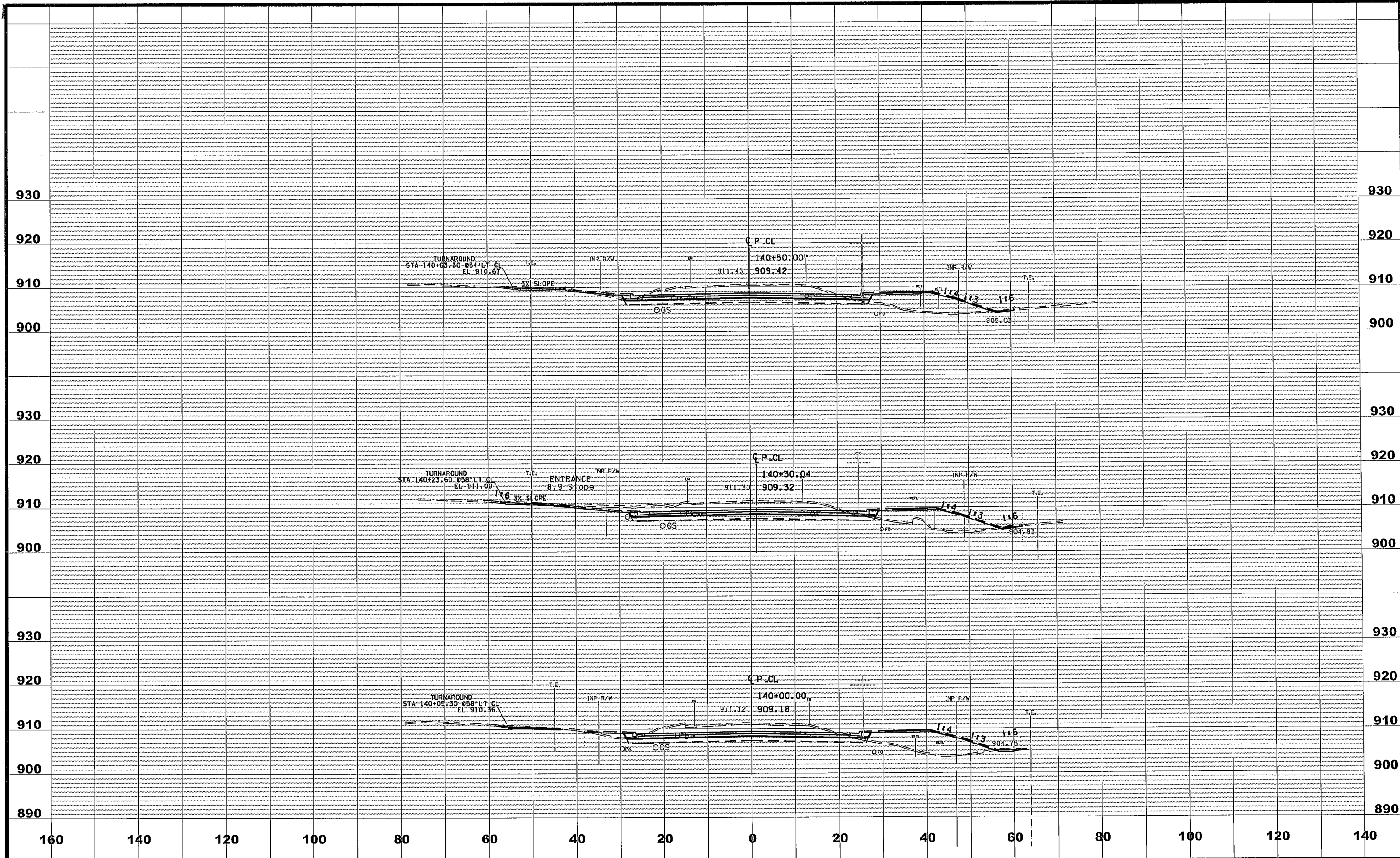

NO	DATE	BY	CKD	APPR	REVISION

NAME: P:\02-621-10\Plan\0262110_XS1_sh.dgn 07/11/2014 2:13:46 PM

DRAWN BY ZB DATE 07-07-14
 DESIGN BY MN DATE 07-07-14
 CHECKED BY CAK DATE 07-11-14

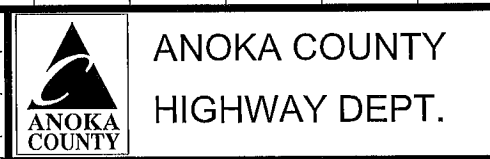

S.A.P. 002-621-010

CROSS SECTIONS
 STA 140+00.03 TO 140+50.04
 Sheet 136 of 147 Sheets

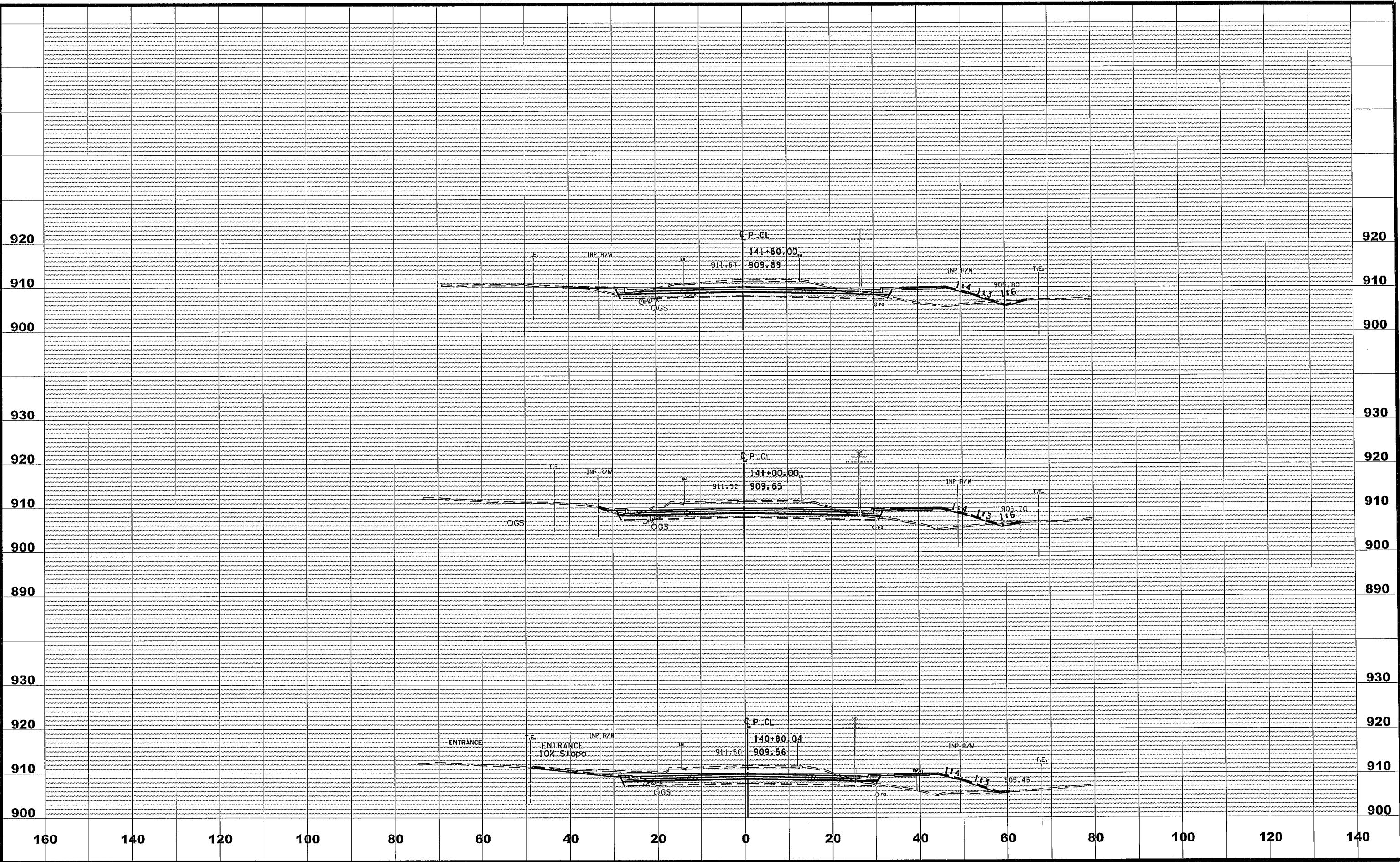

NO	DATE	BY	CKD	APPR	REVISION

NAME: P:\02-621-10\Plan\0262110_XS1_sh.dgn 07/11/2014 2:13:46 PM

DRAWN BY ZB DATE 07-07-14
 DESIGN BY MN DATE 07-07-14
 CHECKED BY CAK DATE 07-11-14

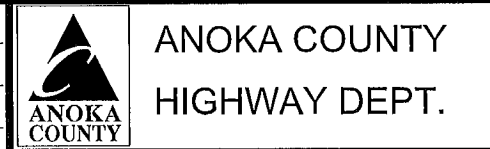

S.A.P. 002-621-010

CROSS SECTIONS
 STA 140+80.04 TO 141+50.05
 Sheet 137 of 147 Sheets

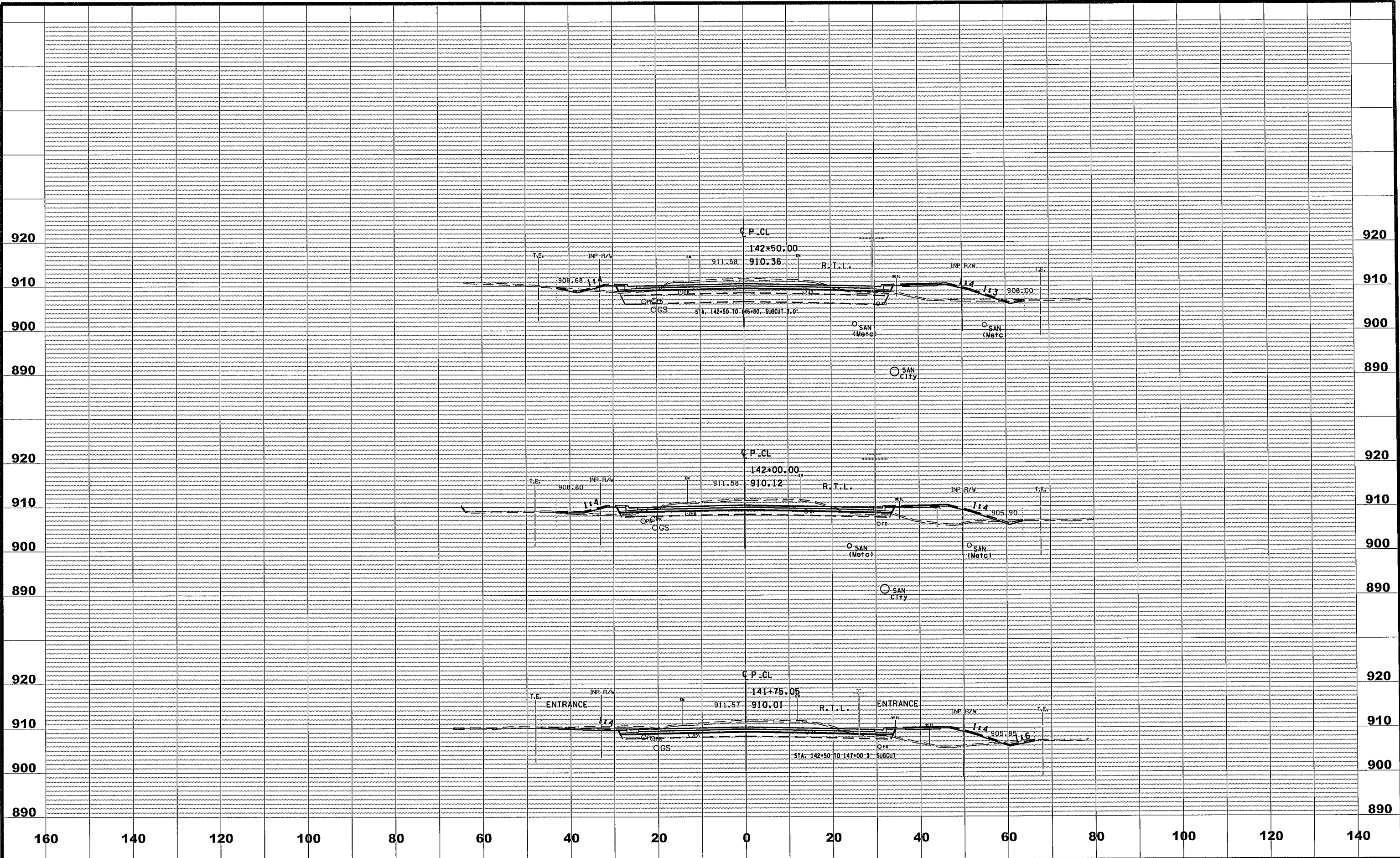

NO	DATE	BY	CKD	APPR	REVISION
NAME: P:\02-621-10\Plan\0262110_XS1_sh.dgn					
07/11/2014 2:13:47 PM					

DRAWN BY ZB DATE 07-07-14
 DESIGN BY MN DATE 07-07-14
 CHECKED BY CAK DATE 07-11-14

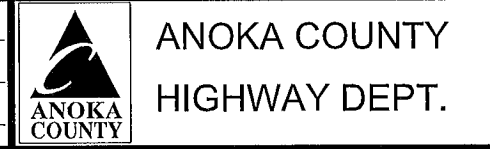

S.A.P. 002-621-010

CROSS SECTIONS
 STA 141+75.05 TO 142+50.05
 Sheet 138 of 147 Sheets

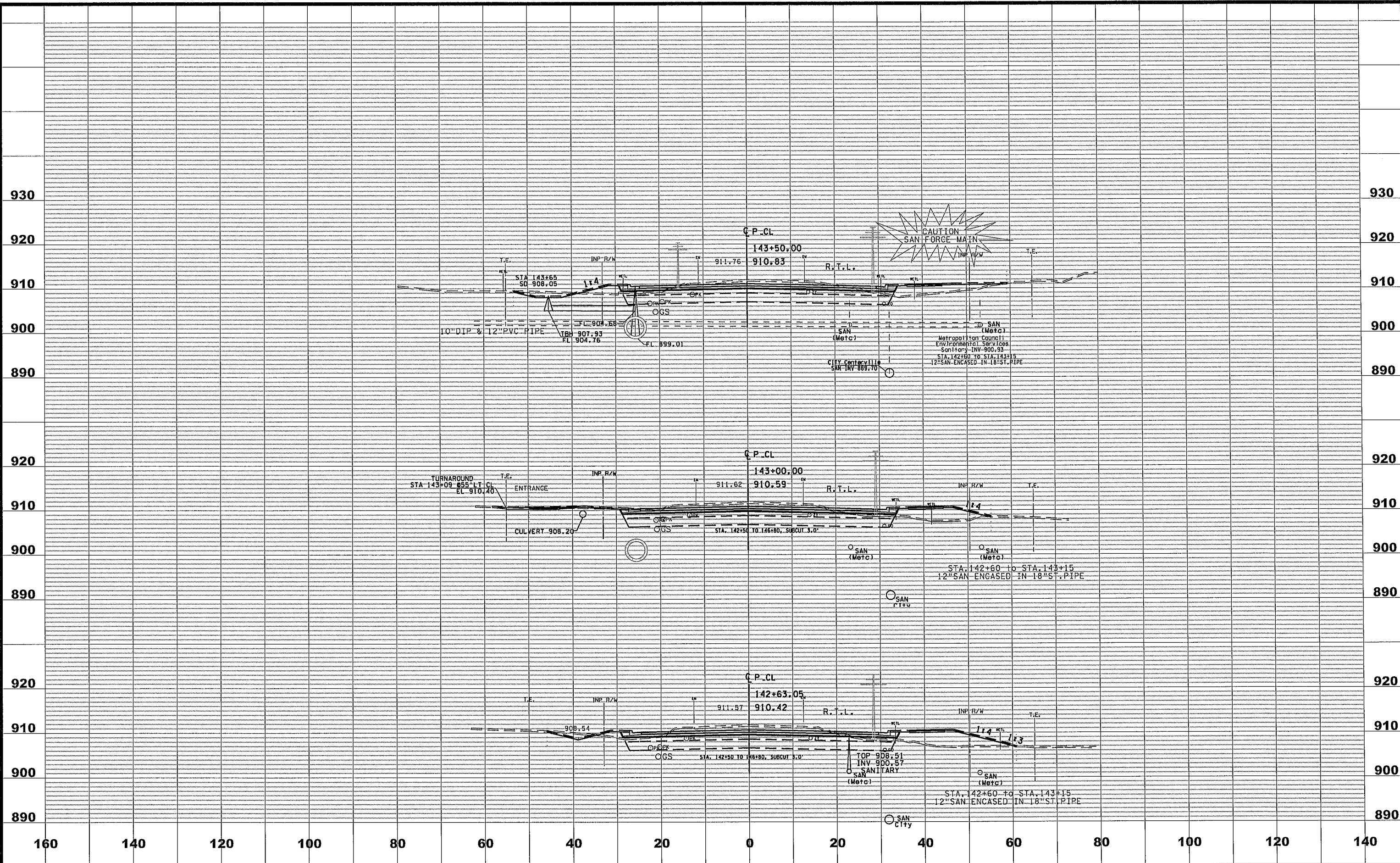

NO	DATE	BY	CKD	APPR	REVISION

NAME: P:\02-621-10\Plan\0262110_XS1_sh.dgn 07/11/2014 2:13:47 PM

DRAWN BY ZB DATE 07-07-14
 DESIGN BY MN DATE 07-07-14
 CHECKED BY CAK DATE 07-11-14

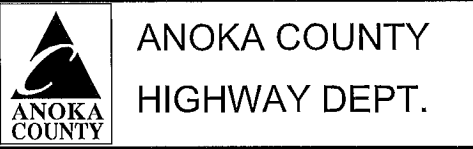

S.A.P. 002-621-010

CROSS SECTIONS
 STA 142+63.05 TO 143+50.05
 Sheet 139 of 147 Sheets

920

910

900

920

910

900

920

910

900

920

910

900

890

920

910

900

920

910

900

920

910

900

920

910

900

890

160 140 120 100 80 60 40 20 0 20 40 60 80 100 120 140

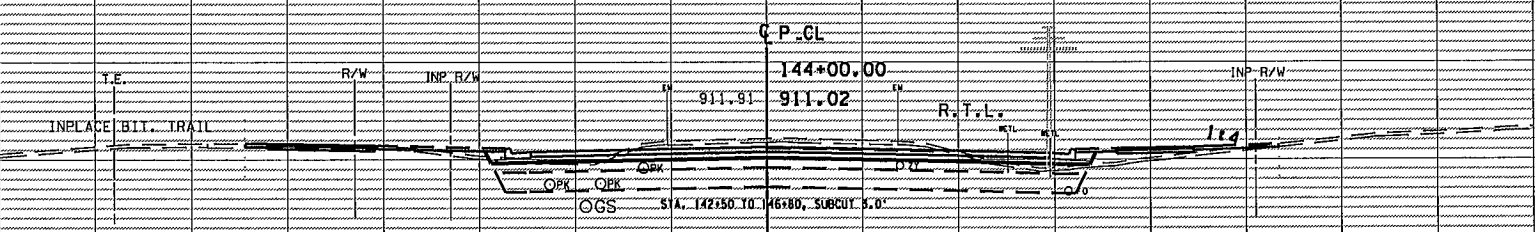
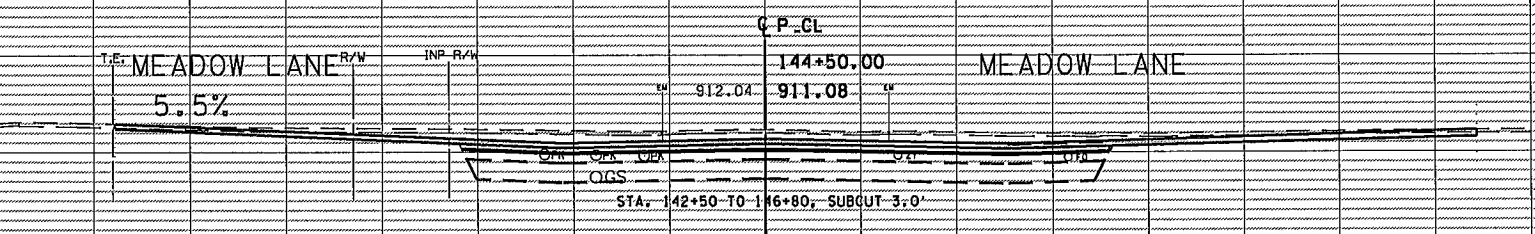
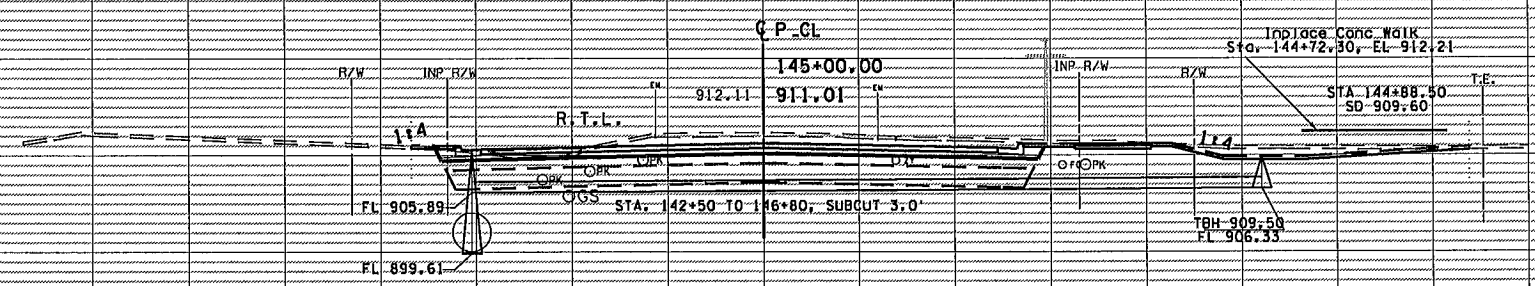
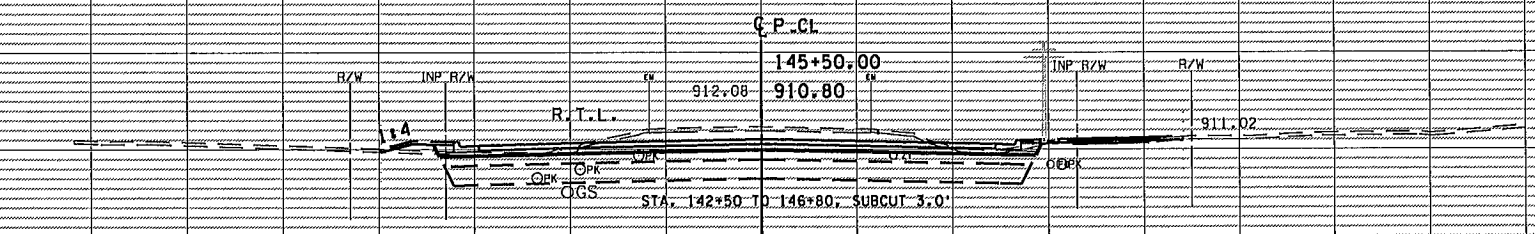

NO	DATE	BY	CKD	APPR	REVISION

NAME: P:\02-621-10\Plan\0262110_XS1_sh.dgn 07/11/2014 2:13:47 PM

DRAWN BY ZB DATE 07-07-14
 DESIGN BY MN DATE 07-07-14
 CHECKED BY CAK DATE 07-11-14

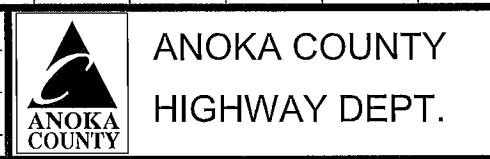

S.A.P. 002-621-010

CROSS SECTIONS
 STA 144+00.05 TO 145+50.05
 Sheet 140 of 147 Sheets

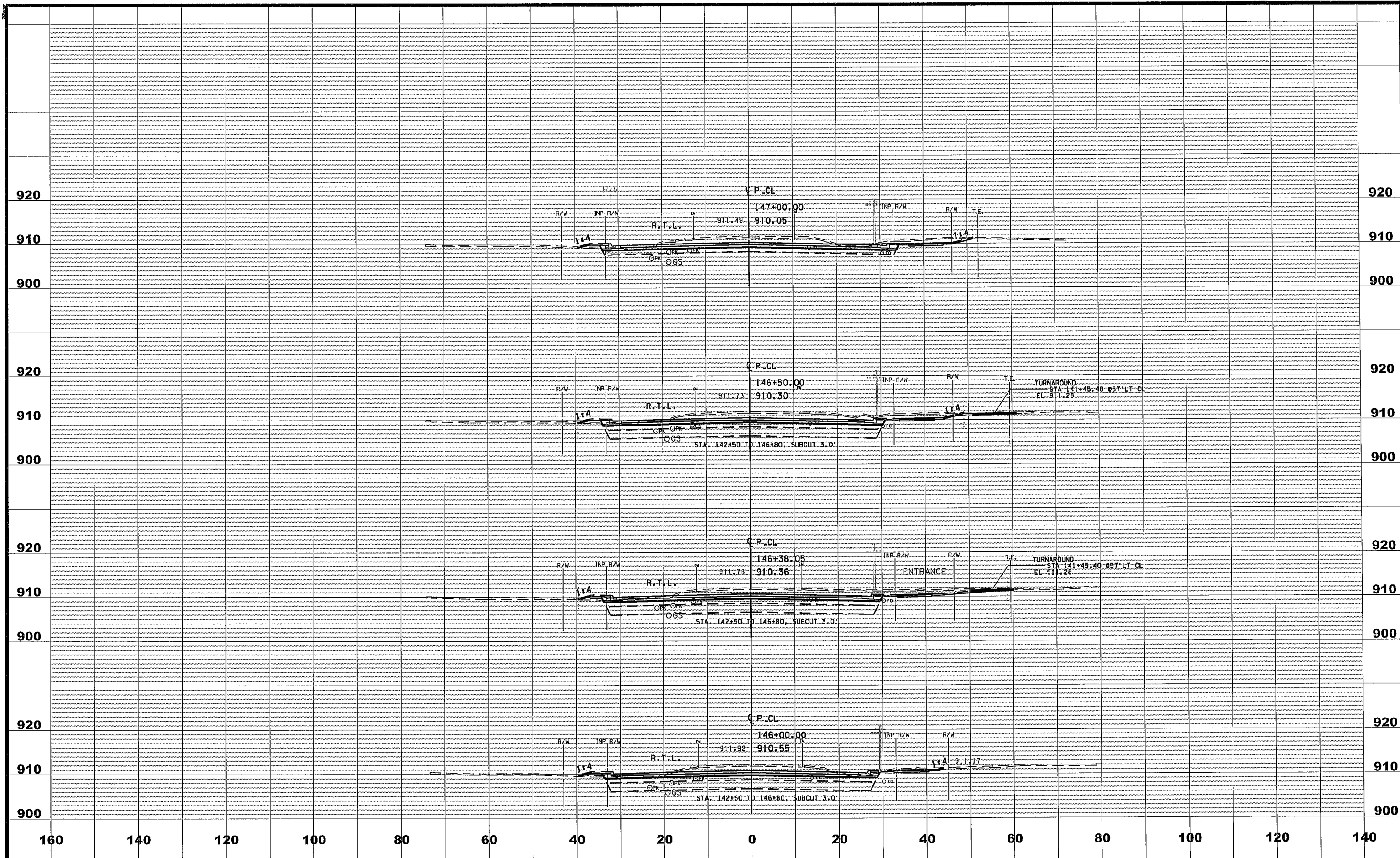

NO	DATE	BY	CKD	APPR	REVISION

NAME: P:\02-621-10\Plan\0262110_XS1_sh.dgn 07/11/2014 2:13:48 PM

DRAWN BY ZB DATE 07-07-14
 DESIGN BY MN DATE 07-07-14
 CHECKED BY CAK DATE 07-11-14

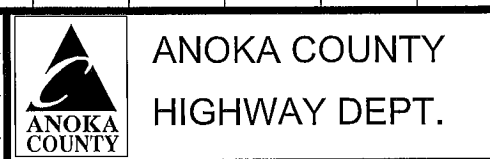

S.A.P. 002-621-010

CROSS SECTIONS
 STA 146+00.05 TO 147+00.05
 Sheet 141 of 147 Sheets

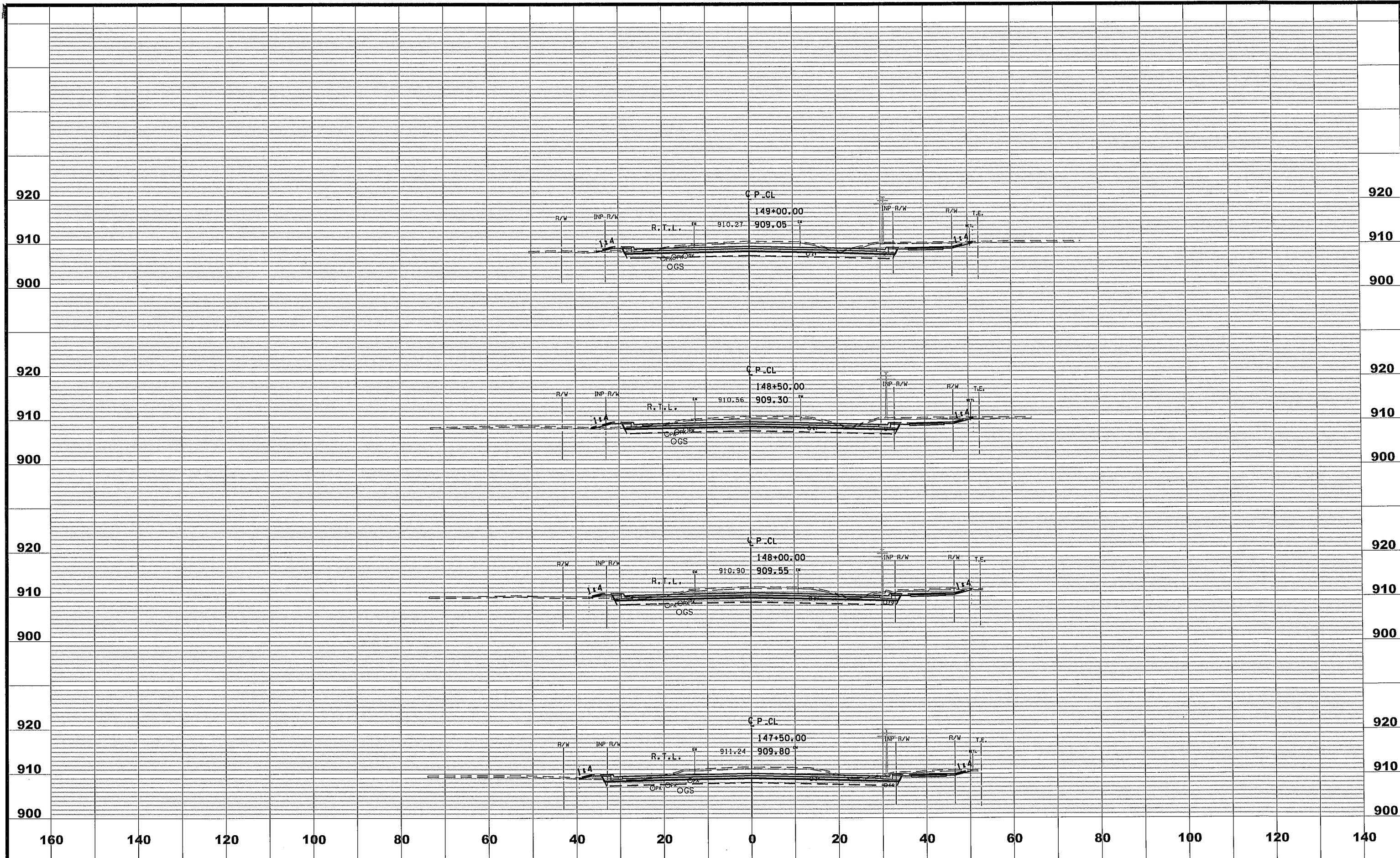

NO	DATE	BY	CKD	APPR	REVISION

NAME: P:\02-621-10\Plan\0262110_XS1_sh.dgn 07/11/2014 2:13:48 PM

DRAWN BY ZB DATE 07-07-14
 DESIGN BY MN DATE 07-07-14
 CHECKED BY CAK DATE 07-11-14

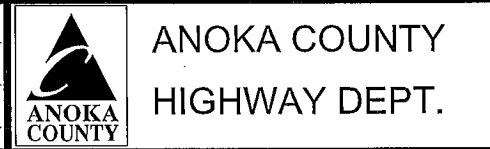

S.A.P. 002-621-010

CROSS SECTIONS
 STA 147+50.05 TO 149+00.05
 Sheet 142 of 147 Sheets

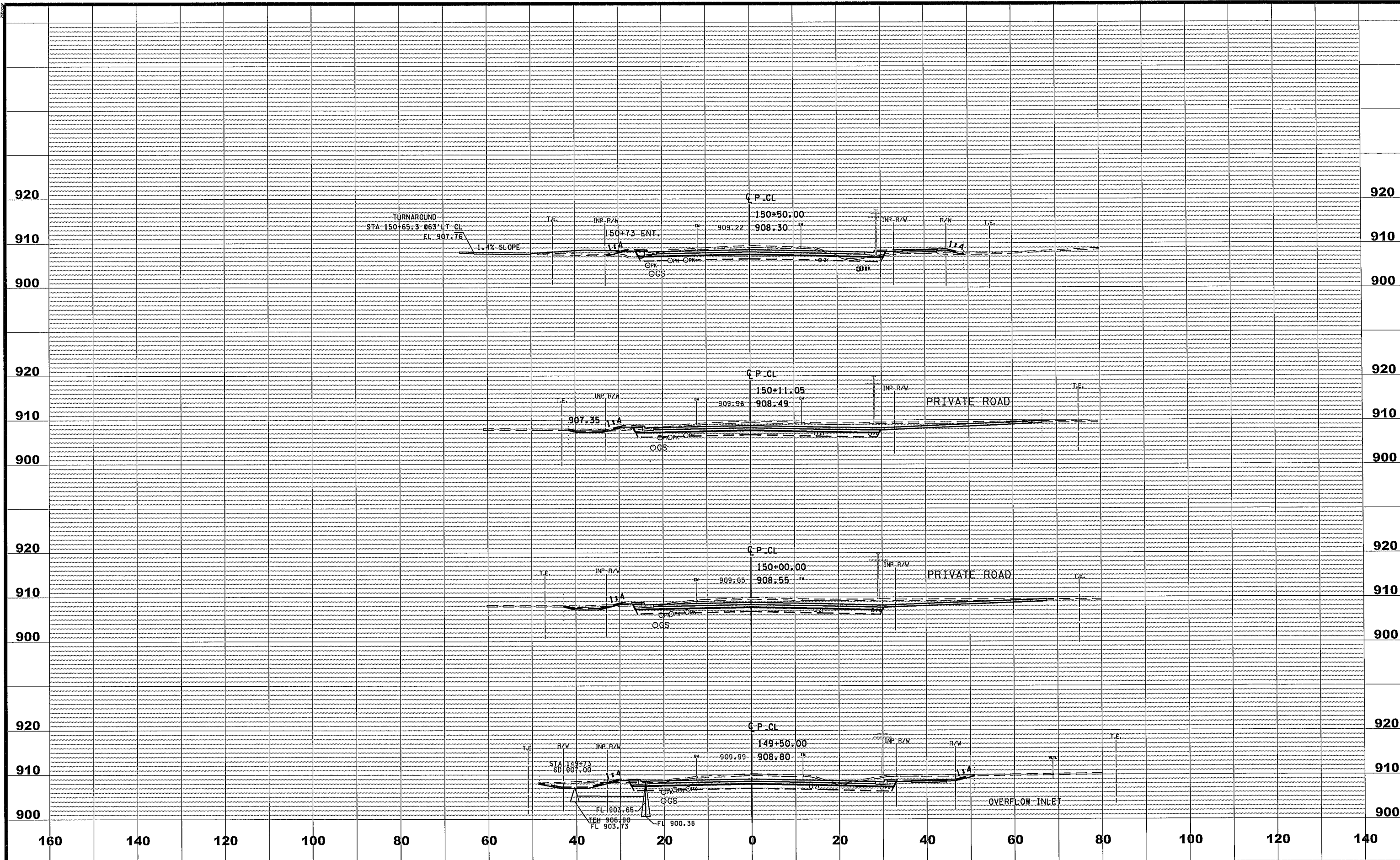

NO	DATE	BY	CKD	APPR	REVISION
NAME: P:\02-621-10\Plan\0262110_XS1_sh.dgn					
07/11/2014 2:13:48 PM					

DRAWN BY ZB DATE 07-07-14
 DESIGN BY MN DATE 07-07-14
 CHECKED BY CAK DATE 07-11-14

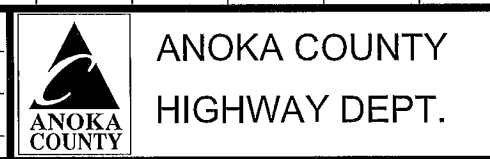

S.A.P. 002-621-010

CROSS SECTIONS
 STA 149+50.05 TO 150+50.05
 Sheet 143 of 147 Sheets

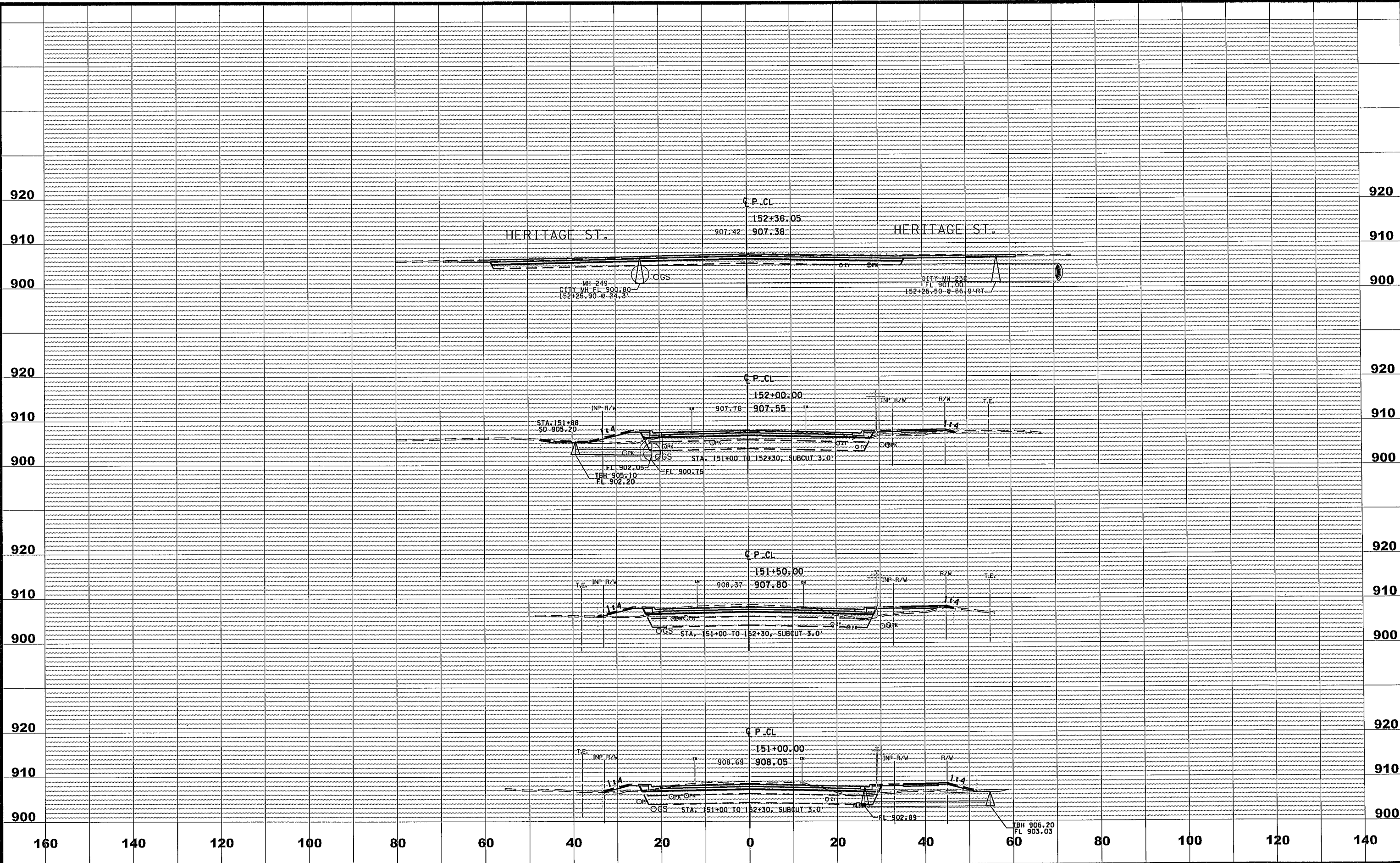

NO	DATE	BY	CKD	APPR	REVISION

NAME: P:\02-621-10\Plan\0262110_XS1_sh.dgn 07/11/2014 2:13:49 PM

DRAWN BY ZB DATE 07-07-14
 DESIGN BY MN DATE 07-07-14
 CHECKED BY CAK DATE 07-11-14

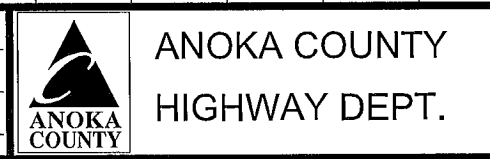

S.A.P. 002-621-010

CROSS SECTIONS
 STA 151+00.05 TO 152+36.05
 Sheet 144 of 147 Sheets

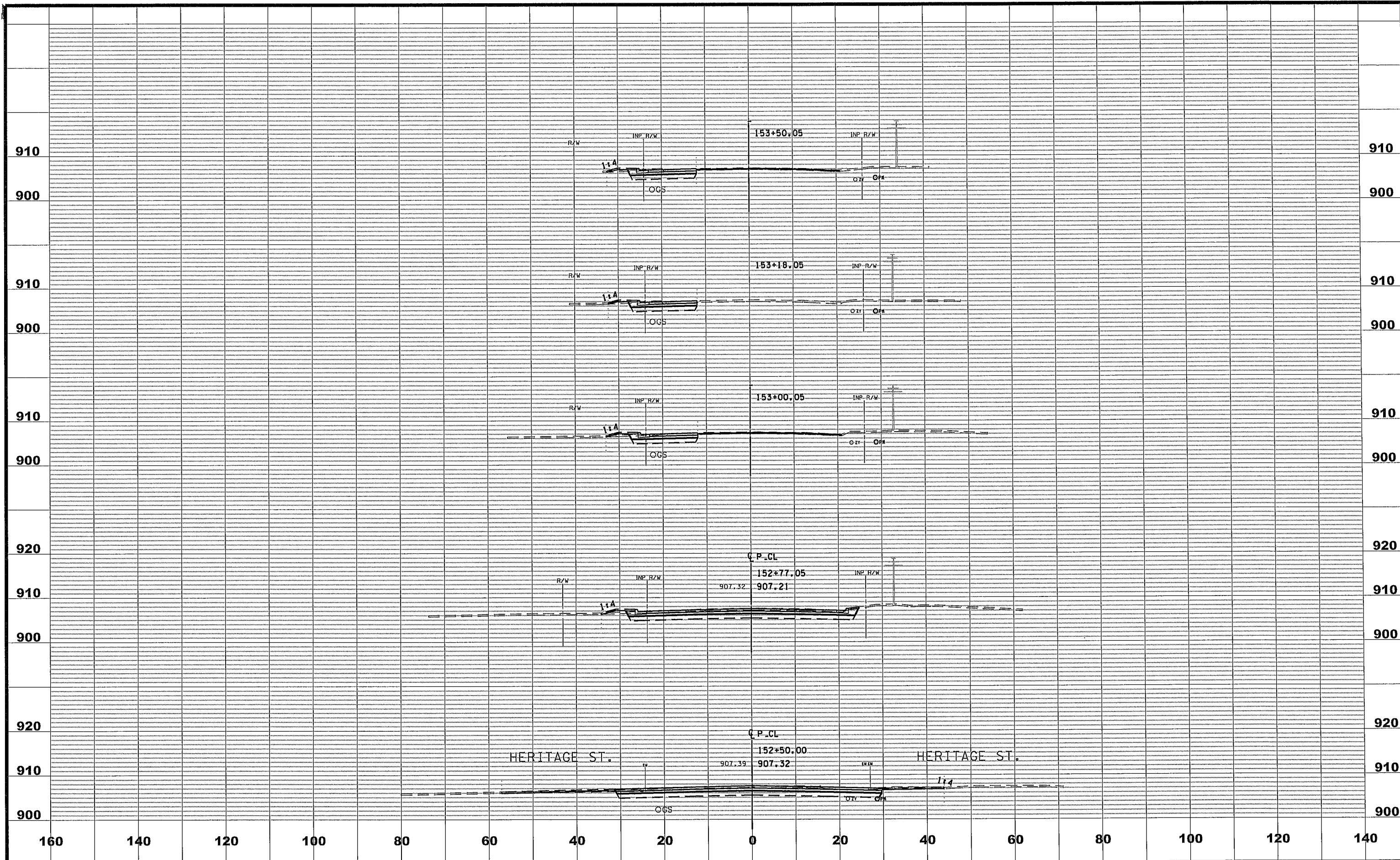

NO	DATE	BY	CKD	APPR	REVISION

NAME: P:\02-621-10\Plan\0262110_XS1_sh.dgn 07/11/2014 2:13:49 PM

DRAWN BY ZB DATE 07-07-14
 DESIGN BY MN DATE 07-07-14
 CHECKED BY CAK DATE 07-11-14

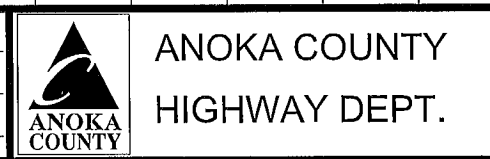

S.A.P. 002-621-010

CROSS SECTIONS
 STA 152+50.05 TO 153+50.05
 Sheet 145 of 147 Sheets

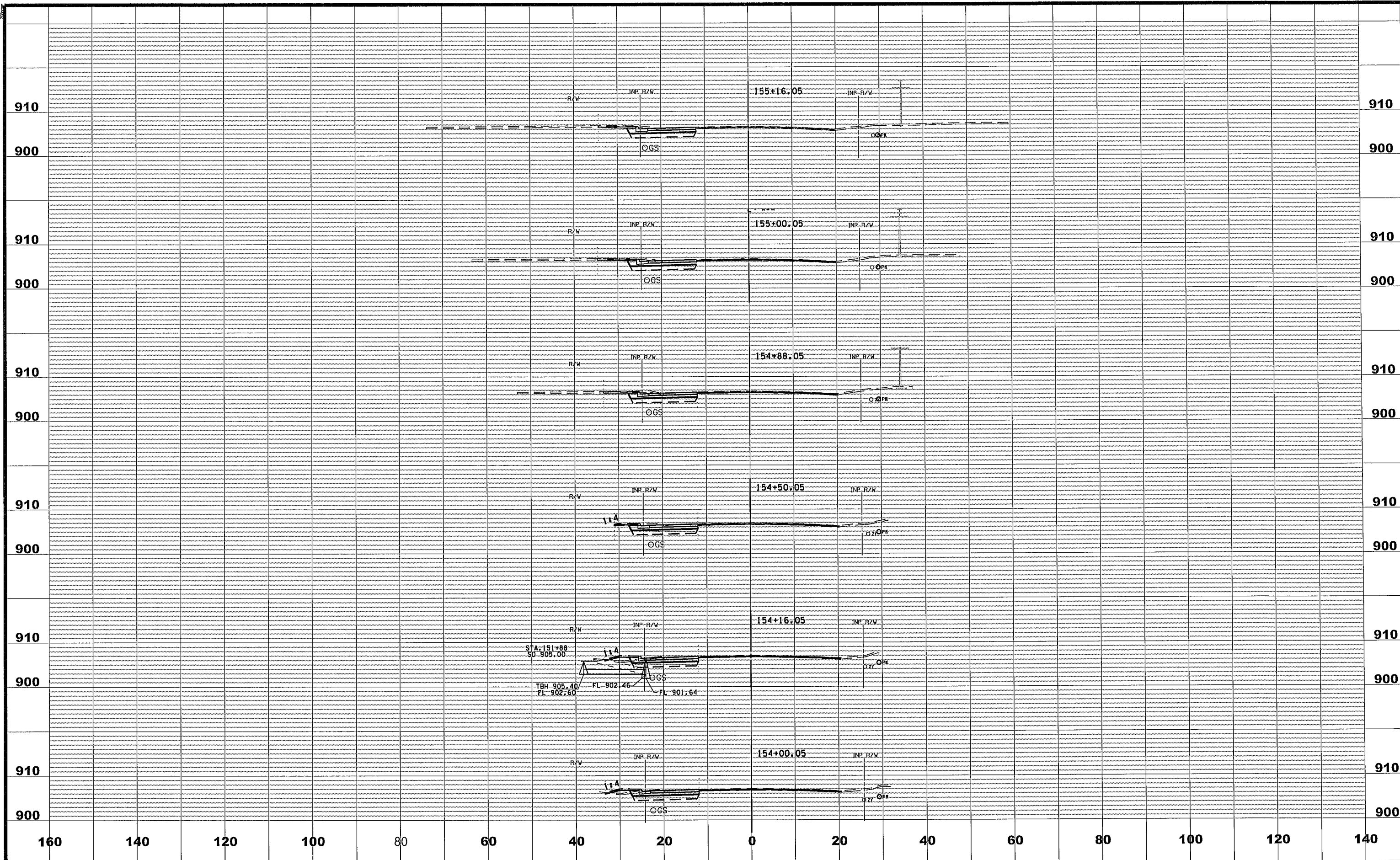

STA. 151+88
 SO 905.00
 TBH 905.40
 FL 902.60
 FL 902.46
 FL 901.64

NO	DATE	BY	CKD	APPR	REVISION
NAME: P:\02-621-10\Plan\0262110_XS1_sh.dgn					
07/11/2014 2:13:49 PM					

DRAWN BY ZB DATE 07-07-14
 DESIGN BY MN DATE 07-07-14
 CHECKED BY CAK DATE 07-11-14



ANOKA COUNTY
HIGHWAY DEPT.

S.A.P. 002-621-010

CROSS SECTIONS
 STA 154+00.05 TO 155+16.05
 Sheet 146 of 147 Sheets

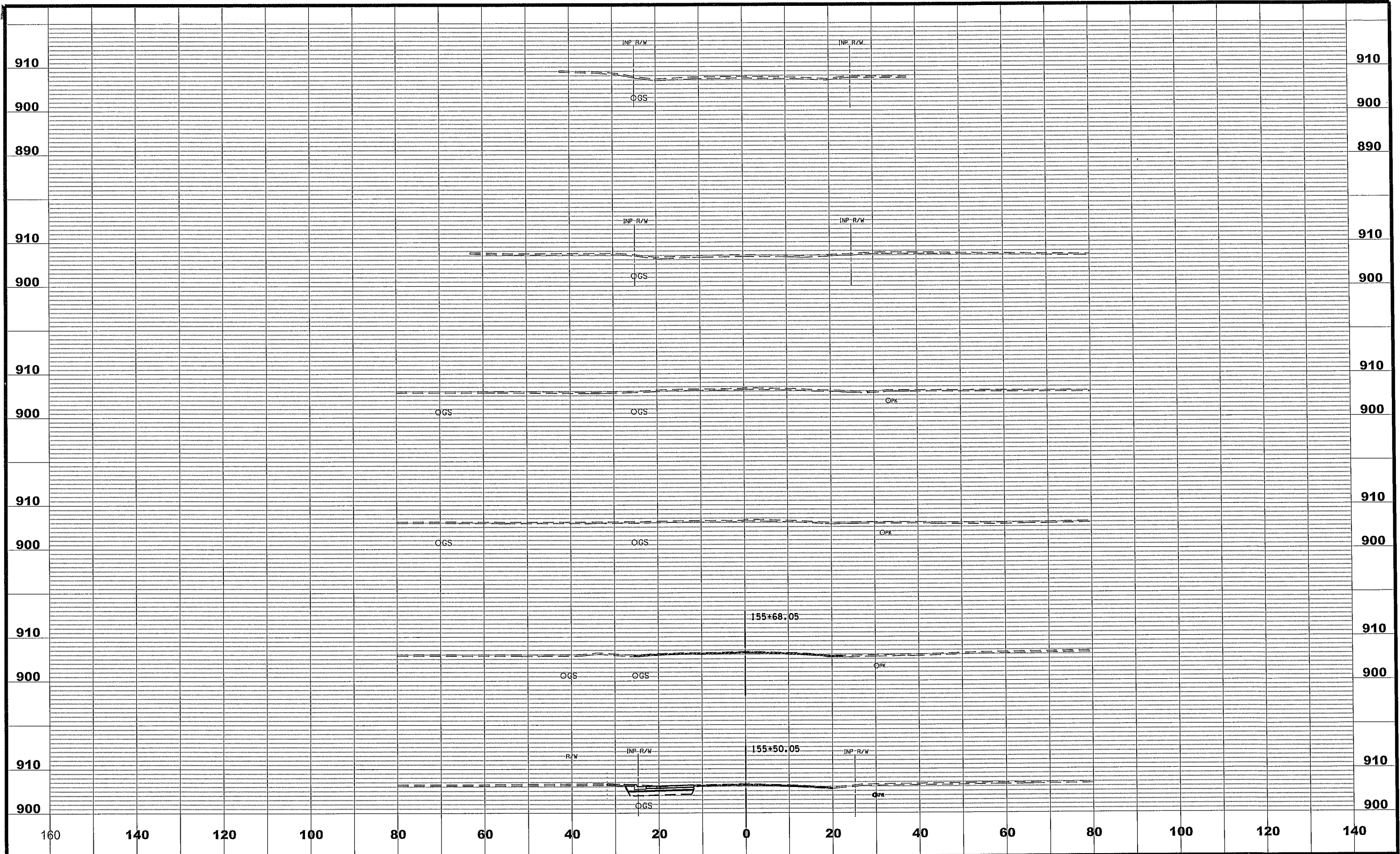

NO	DATE	BY	CKD	APPR	REVISION
NAME: P:\02-621-10\Plan\0262110_XS1_sh.dgn 07/11/2014 2:13:50 PM					

--	--	--	--	--	--

DRAWN BY ZB DATE 07-07-14
 DESIGN BY MN DATE 07-07-14
 CHECKED BY CAK DATE 07-11-14

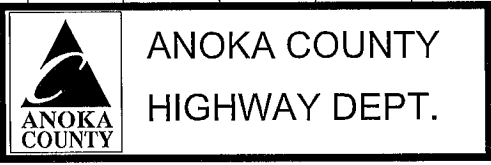

S.A.P. 002-621-010

CROSS SECTIONS
 STA 155+50.05 TO 155+68.05
 Sheet 147 of 147 Sheets