

PLAN SYMBOLS

- COUNTY LINE
- TOWNSHIP OR RANGE LINE
- SECTION LINE
- QUARTER LINE
- SIXTEENTH LINE
- RIGHT OF WAY LINE
- SLOPE EASEMENT
- PRESENT RIGHT OF WAY
- PROPERTY LINE
- CORPORATE OR CITY LIMITS
- RETAINING WALL
- RAILROAD
- RAILROAD RIGHT OF WAY
- RIVER OR CREEK
- DRAINAGE DITCH
- CULVERT
- DROP INLET
- GAIRD RAIL
- BARBED WIRE FENCE
- WOVEN WIRE FENCE
- CHAIN LINK FENCE
- WOOD FENCE
- STONE WALL OR FENCE
- HEDGE

- LOWLAND
- TIMBER
- ORCHARD
- BRUSH
- NURSERY

- CATTLE GAIRD
- OVERPASS (Highway Over)
- UNDERPASS (Highway Under)
- BRIDGE

- BUILDING (One Story Frame)
- F-FRAME C-CONCRETE
- S-STONE T-TILE
- B-BRICK ST-STUCCO
- RAILROAD CROSSING BELL
- RAILROAD CROSSING GATE
- MANHOLE
- CATCH BASIN
- FIRE HYDRANT
- CAST IRON MONUMENT
- IRON PIN
- GRAVEL PIT
- SAND PIT
- BORROW PIT
- ROCK QUARRY

UTILITY SYMBOLS

- POWER POLE LINE
- TELEPHONE OR TELEGRAPH POLE LINE
- JOINT TELEPHONE & POWER ON POWER POLES
- ON TELEPHONE POLES
- ANCHOR
- STEEL TOWER
- STREET LIGHT
- PEDESTAL (Cable Terminal)
- GAS MAIN
- WATERMAIN
- TELEPHONE CABLE IN CONDUIT
- ELECTRIC CABLE IN CONDUIT
- TELEPHONE MANHOLE
- ELECTRIC MANHOLE
- BURIED TELEPHONE CABLE
- BURIED ELECTRIC CABLE
- AERIAL TELEPHONE CABLE
- SEWER (Sanitary or Storm)
- SEWER MANHOLE

SCALES

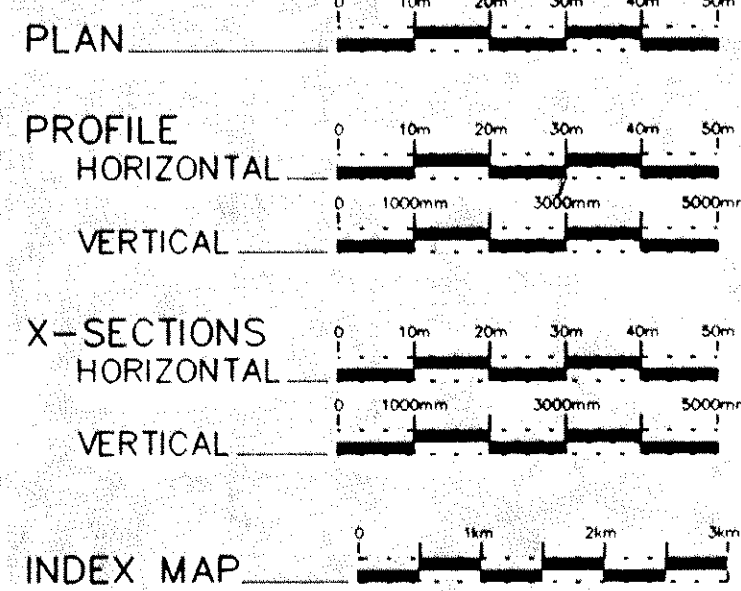

MINNESOTA DEPARTMENT OF TRANSPORTATION

ANOKA COUNTY

CONSTRUCTION PLAN FOR GRADING, AGG.BASE, BITUMINOUS SURFACING, DRAINAGE, CURB & GUTTER AND SIGNAL SYSTEM.

LOCATED ON INTERSECTION OF C.S.A.H. 78 AND C.S.A.H. 116 (Geographic Description)

STATE PROJ. NO. 02-678-12
C.S.A.H. 78

STATE PROJ. NO. 02-716-02
C.S.A.H. 116

GROSS LENGTH 746.550 METERS 0.747 KILOMETERS
 BRIDGES-LENGTH 0.000 METERS 0.000 KILOMETERS
 EXCEPTIONS-LENGTH 0.000 METERS 0.000 KILOMETERS
 NET LENGTH 746.550 METERS 0.747 KILOMETERS

GROSS LENGTH 702.730 METERS 0.703 KILOMETERS
 BRIDGES-LENGTH 0.000 METERS 0.000 KILOMETERS
 EXCEPTIONS-LENGTH 20.100 METERS 0.020 KILOMETERS
 NET LENGTH 682.630 METERS 0.683 KILOMETERS

END S.P. 02-678-12 STA. 20+750.000
 BEGIN S.P. 02-678-12 STA. 20+003.450

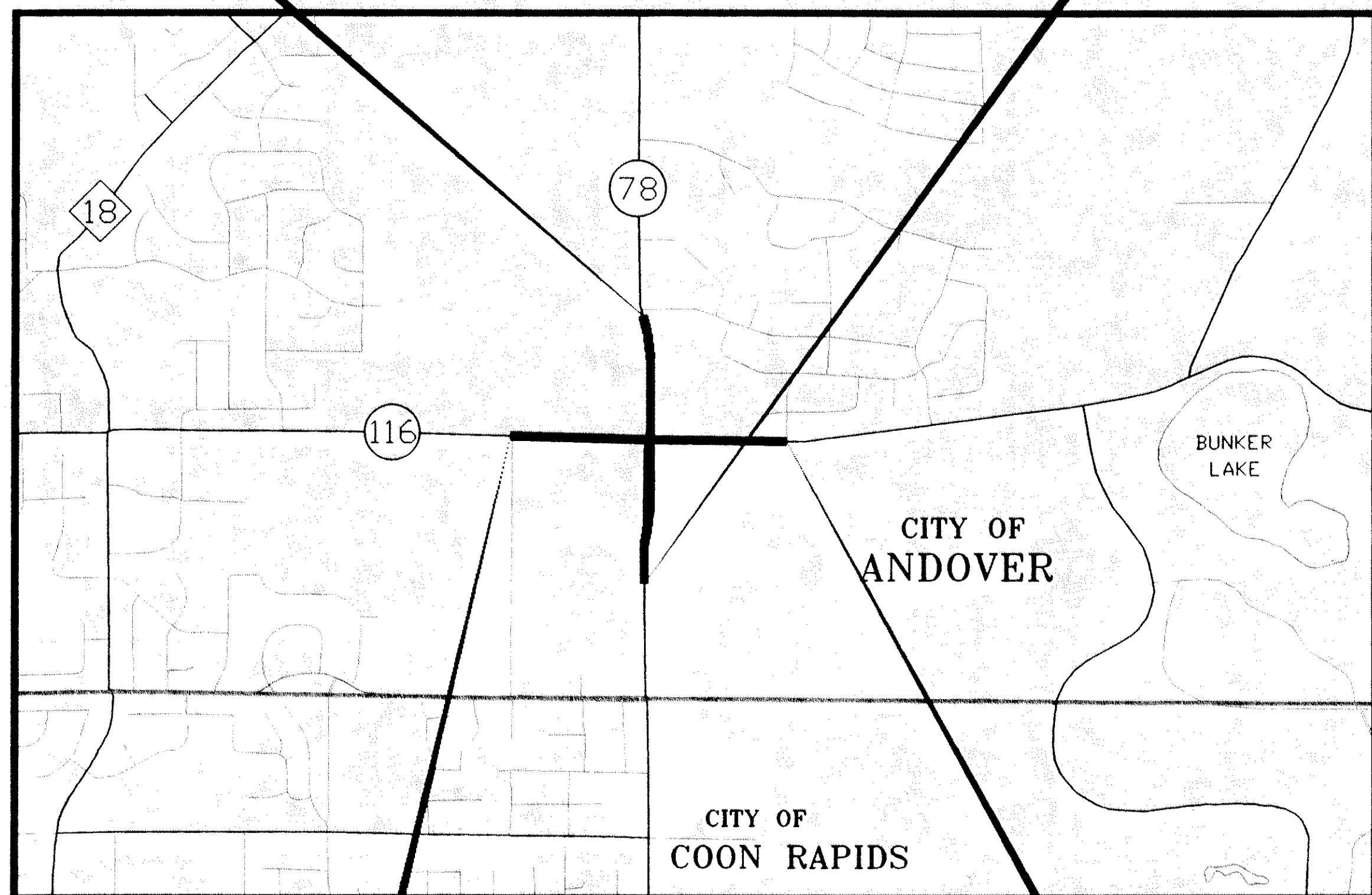

BEGIN S.P. 02-716-02 STA. 5+072.580

END S.P. 02-716-02 STA. 5+775.310

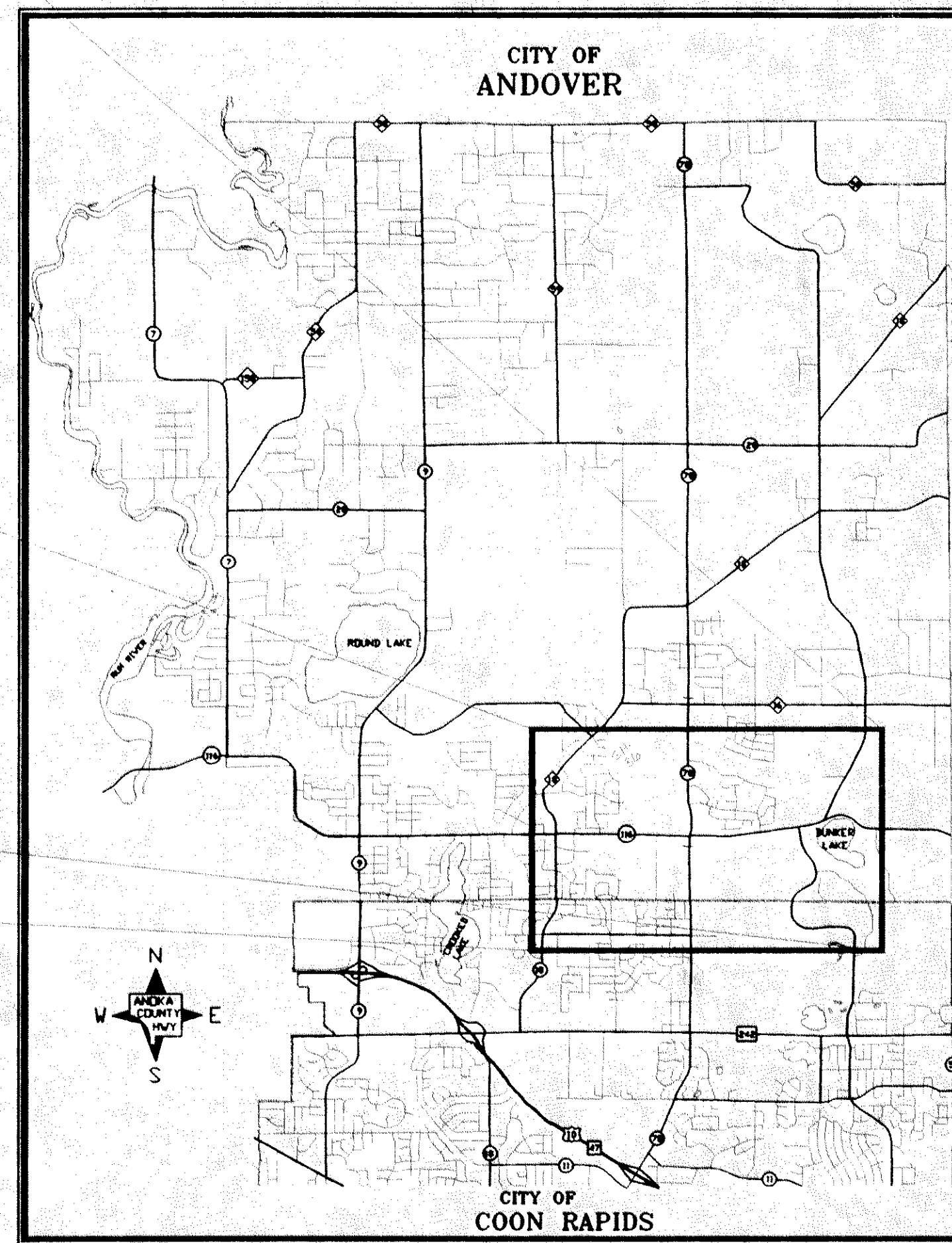
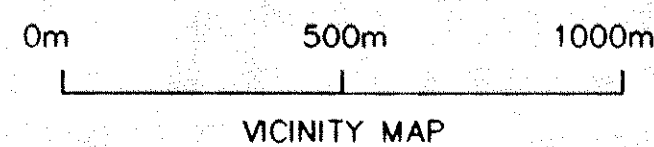

MINN. PROJ. NO. _____
 MINN. PROJ. NO. _____

GOVERNING SPECIFICATIONS

THE 1995 EDITION OF THE MINNESOTA DEPARTMENT OF TRANSPORTATION "STANDARD SPECIFICATIONS FOR CONSTRUCTION" SHALL GOVERN. ALL TRAFFIC CONTROL DEVICES SHALL CONFORM TO THE MMUTCD, INCLUDING "FIELD MANUAL FOR TEMPORARY TRAFFIC CONTROL ZONE LAYOUTS - APRIL 1995."

INDEX

SHEET NO.	DESCRIPTION
1	TITLE SHEET
2	STATEMENT OF ESTIMATED QUANTITIES
3	TABULATION CHARTS
4	EARTHWORK SUMMARY
5 - 6	EROSION CONTROL DETAILS
7	TYPICAL SECTIONS
8 - 9	EXISTING CONDITIONS AND REMOVAL PLAN
10 - 13	PLAN AND PROFILE
14 - 25	CROSS-SECTION
26 - 27	DETOUR PLANS

THIS PLAN CONTAINS 27 SHEETS

DESIGN DESIGNATION

ESAL ₂₀	3,006,936
R VALUE	70
ADT (1997)	15,545
Proj. ADT (2019)	26,426
Proj. HCADT (2019)	1,982
Soil Factor	NA
8.2 METRIC TON DESIGN	

Functional Classification ARTERIAL HIGH DENSITY
 No. of Traffic Lanes 2 No. of Parking Lanes 0
 Design Speed 90 Km/h
 Based on Stopping Sight Distance
 Height of eye 1,070mm Height of object 150mm
 Design Speed not achieved at:

STA. _____	TO STA. _____	MPH _____
STA. _____	TO STA. _____	MPH _____
STA. _____	TO STA. _____	MPH _____

Approved _____, 19 _____ ANOKA COUNTY ENGINEER
 Approved _____, 19 _____ CITY OF ANDOVER
 Recommended for Approval _____, 19 _____ METRO-ASSISTANT DIVISION ENGINEER-STATE AID
 Approved for State Aid Division _____, 19 _____ STATE AID ENGINEER

NO	DATE	BY	CKD	APPR	REVISION

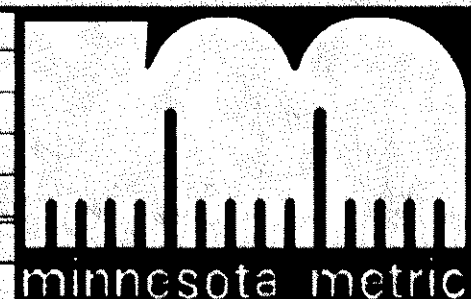

I HEREBY CERTIFY THAT THIS PLAN WAS PREPARED BY ME OR UNDER MY DIRECT SUPERVISION AND THAT I AM A DULY REGISTERED PROFESSIONAL ENGINEER UNDER THE LAWS OF THE STATE OF MINNESOTA.

DATE _____ REG. NO. _____

DRAWN BY _____ DATE _____
 DESIGN BY _____ DATE _____
 CHECKED BY _____ DATE _____

STATE PROJECT NO. 02-678-12
 STATE PROJECT NO. 02-716-02
 STATE AID PROJECT NO. _____
 COUNTY PROJECT NO. _____

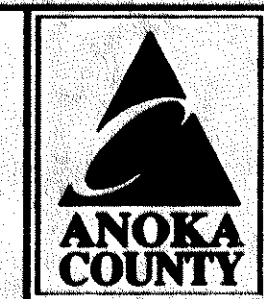

ANOKA COUNTY
HIGHWAY DEPT.

TITLE SHEET
 Sheet 1 of 27 Sheets

M. U. T. C. D. CODE	SIZE		PANEL AREA		INSERT	QTY	MOUNTING POST PER INSTALLATION		MOUNTING HEIGHT	
	INCHES	mm	FT ²	m ²			FT.	m	FT.	m
R1-1	30" x 30"	760mm X 760mm	6.25	0.580		11	1	7.0'	2.1	
R2-1	24" x 30"	610mm X 760mm	5.00	0.460		3	1	7.0'	2.1	
R2-1	24" x 30"	610mm X 760mm	5.00	0.460		1	1	7.0'	2.1	
R3-X1	30" x 30"	760mm X 760mm	6.25	0.580		9	1	7.0'	2.1	
R3-X2	30" x 30"	760mm X 760mm	6.25	0.580		4	1	7.0'	2.1	
R3-4	24" x 24"	610mm X 610mm	4.00	0.370		4				
R4-7	24" x 30"	610mm X 760mm	6.25	0.580		8	1	7.0'	2.1	
X4-2	18" x 18"	455mm X 455mm	2.25	0.210		8				
R5-1	24" x 30"	610mm X 760mm	6.25	0.580		13	1	7.0'	2.1	
R6-1R	36" x 12"	910mm X 305mm	3.00	0.280		5				
R6-1R	48" x 18"	1220mm X 455mm	6.00	0.550		5	2	7.0'	2.1	

①
②
③
④

M. U. T. C. D. CODE	SIZE		PANEL AREA		INSERT	QTY	MOUNTING POST PER INSTALLATION		MOUNTING HEIGHT	
	INCHES	mm	FT ²	m ²			FT.	m	FT.	m
W1-4L	36" x 36"	910mm X 910mm	9.00	0.830		1	2	7.0'	2.1	
W3-3	36" x 36"	910mm X 910mm	9.00	0.830		4	2	7.0'	2.1	
X4-4L	12" x 36"	305mm X 910mm	3.00	0.280		4	1	5.0'	1.5	
M2-1A	21" x 15"	530mm X 380mm	2.18	0.200		2				
M3-1A	24" x 12"	610mm X 305mm	2.00	0.180		1				
M3-3A	24" x 12"	610mm X 305mm	2.00	0.180		1				
M1-6A	24" x 24"	610mm X 610mm	4.00	0.370		6	1	7.0'	2.1	
M6-4A	21" x 15"	530mm X 380mm	2.18	0.200		2				
M2-1A	21" x 15"	530mm X 380mm	2.18	0.200		2				
M3-2A	24" x 12"	610mm X 305mm	2.00	0.180		1				
M3-4A	24" x 12"	610mm X 305mm	2.00	0.180		1				
M1-6A	24" x 24"	610mm X 610mm	4.00	0.370		6	1	7.0'	2.1	
M6-4A	21" x 15"	530mm X 380mm	2.18	0.200		2				

* NOTE:
 ① MOUNTED BEHIND R4-7
 ② MOUNTED BELOW R4-7
 ③ MOUNTED ABOVE R1-1
 ④ 2 MOUNTED BACK TO BACK

NOTE:
 1) LOCATIONS OF 'NO PASSING ZONES' ARE APPROXIMATE. EXACT LOCATIONS WILL BE DETERMINED IN THE FIELD.
 2) ALL TRAFFIC CONTROL DEVICES SHALL CONFORM TO THE MINNESOTA MANUAL ON TRAFFIC CONTROL DEVICES, INCLUDING THE FIELD MANUAL DATED APRIL, 1995.

NO	DATE	BY	CKD	APPR	REVISION

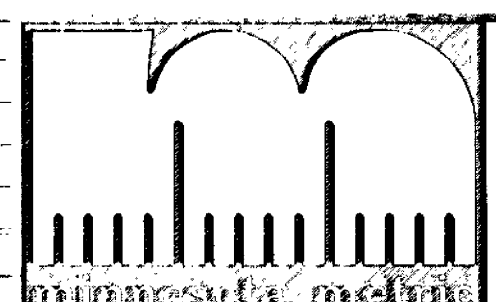

I HEREBY CERTIFY THAT THIS PLAN WAS PREPARED BY ME OR UNDER MY DIRECT SUPERVISION AND THAT I AM A DULY REGISTERED PROFESSIONAL ENGINEER UNDER THE LAWS OF THE STATE OF MINNESOTA.
 DATE _____ REG. NO. _____

DRAWN BY _____ DATE _____
 DESIGN BY _____ DATE _____
 CHECKED BY _____ DATE _____

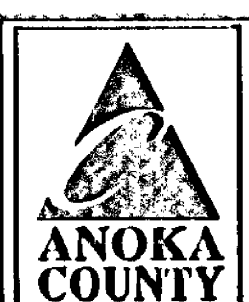

ANOKA COUNTY
HIGHWAY DEPT.

STATE PROJECT NO. 02-678-12/02-716-02
 STATE PROJECT NO. _____
 STATE AID PROJECT NO. _____
 COUNTY PROJECT NO. _____

PERMANENT
SIGN QUANTITIES
 Sheet 26 of 59 Sheets

M. U. T. C. D. CODE	SIZE	INSERT	STAGE I	STAGE II	STAGE III	STAGE IV
			QTY	QTY	QTY	QTY
R1-1	48" x 48"		8	9	19	17
R1-4	18" x 6"		8	8	8	8
R4-1	24" x 30"		0	2	2	0
R3-X1	30" x 30"		0	0	4	0
R4-7A	24" x 30"		0	2	1	18
X4-2	18" x 18"		0	2	1	18
R5-1	30" x 30"		0	0	0	13
W1-6	48" x 24"		0	3	1	0
TYPE III	8 FT.		0	9	20	0
W1-6L	48" x 24"		0	1	0	0
TYPE III	8 FT.		0	1	0	0
TYPE III	8 FT.		0	3	7	23
W3-1a	48" x 48"		8	8	8	8
X4-4	12" x 36"		0	2	2	11
R6-1R	36" x 12"		0	0	0	14
R6-1L	36" x 12"		0	0	0	2
R3-2	24" x 24"		0	0	0	1

M. U. T. C. D. CODE	SIZE	INSERT	STAGE I	STAGE II	STAGE III	STAGE IV
			QTY	QTY	QTY	QTY
W6-3	48" x 48"		0	2	2	0
W20-1	48" x 48"		4	4	4	4
	48" x 48"		8	8	8	8
W21-X1	48" x 48"		0	2	7	8
G20-2A	48" x 24"		4	4	4	4
REBOUNDABLE DRUM REFLECTORIZED			0	63	282	241
G20-X2	96" x 84"		2	2	2	2
	12" x 84"		2	2	2	2
G20-X2	96" x 84"		2	2	2	2
	12" x 84"		2	2	2	2

NOTES:

1. ALL TRAFFIC CONTROL DEVICES SHALL CONFORM TO THE MINNESOTA MANUAL ON UNIFORM TRAFFIC CONTROL DEVICES, INCLUDING THE FIELD MANUAL DATED JANUARY, 1998.
2. PAVEMENT MARKINGS IN ALL TAPER AREAS SHALL HAVE TEMPORARY RAISED PAVEMENT MARKERS AT 3m INTERVALS.
3. ALL TYPE III BARRICADES SHALL BE REFLECTORIZED ON BOTH SIDES, AND BARRICADE MARKINGS SHALL BE SLANTED IN ACCORDANCE WITH THE MINNESOTA MANUAL ON UNIFORM TRAFFIC CONTROL DEVICES.

NO	DATE	BY	CKD	APPR	REVISION



I HEREBY CERTIFY THAT THIS PLAN WAS PREPARED BY ME OR UNDER MY DIRECT SUPERVISION AND THAT I AM A DULY REGISTERED PROFESSIONAL ENGINEER UNDER THE LAWS OF THE STATE OF MINNESOTA.

DATE _____ REG. NO. _____

DRAWN BY _____ DATE _____
 DESIGN BY _____ DATE _____
 CHECKED BY _____ DATE _____

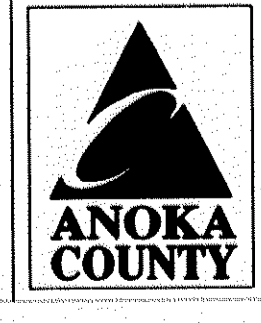



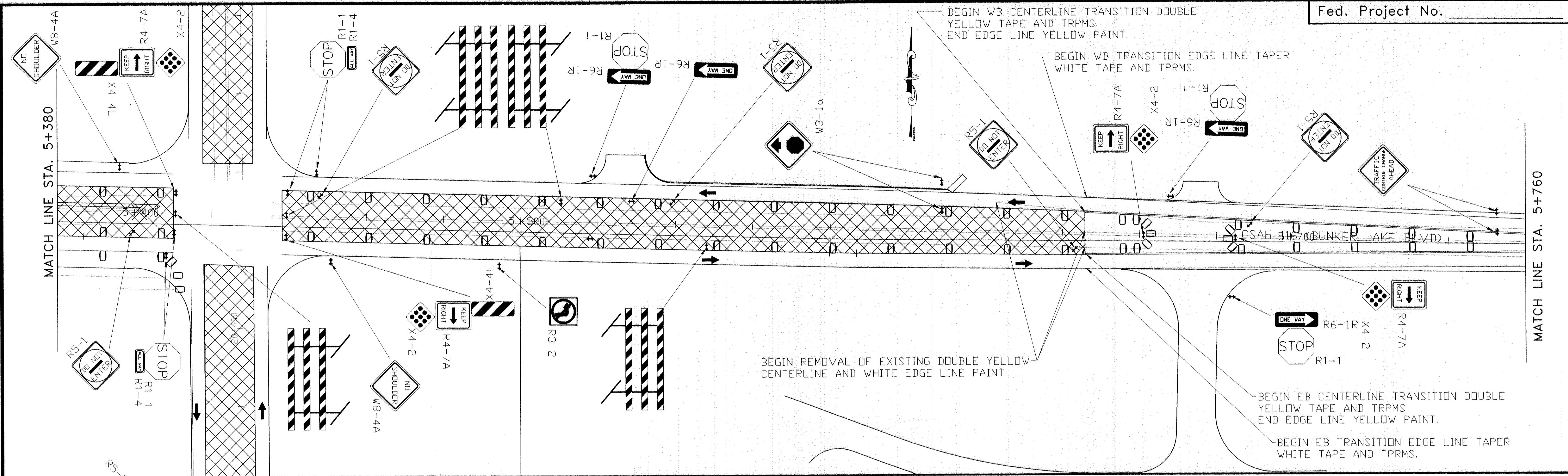

ANOKA COUNTY
HIGHWAY DEPT.

STATE PROJECT NO. 02-678-12/02-716-02
 STATE AID PROJECT NO. _____
 STATE AID PROJECT NO. _____
 COUNTY PROJECT NO. _____

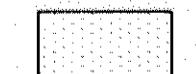
STAGE QUANTITIES
 HANSON BLVD
 C.S.A.H. 78
 Sheet 59 of 59 Sheets



 STORM SEWER INSTALLATION	 FULL DEPTH CON.
 TEMP PAVEMENT CONSTRUCTION	 MEDIAN CONSTRUC

1	6/15/99	RB	JP	LR	CHANGE IN WEST LEG OF INTERSECTION FROM RURAL TO URBAN; COORDINATE STAGING WITH SAP 02-716-04
NO	DATE	BY	CKD	APPR	REVISION
NAME: F:\0267812\WORK\STAGE 4 2-6-98 10:31:50 am EST					

I HEREBY CERTIFY THAT THIS PLAN WAS PREPARED BY ME OR UNDER MY DIRECT SUPERVISION AND THAT I AM A DULY REGISTERED PROFESSIONAL ENGINEER UNDER THE LAWS OF THE STATE OF MINNESOTA.



DATE _____ REG. NO. _____

DRAWN BY _____ DATE _____

DESIGN BY _____ DATE _____

CHECKED BY _____ DATE _____

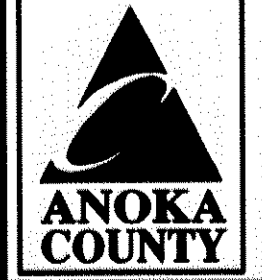

ANOKA COUNTY
HIGHWAY DEPT.

STATE PROJ. NO. 02-678-12/02-716-02
 STATE AID PROJECT NO. _____
 STATE AID PROJECT NO. _____
 COUNTY PROJECT NO. _____

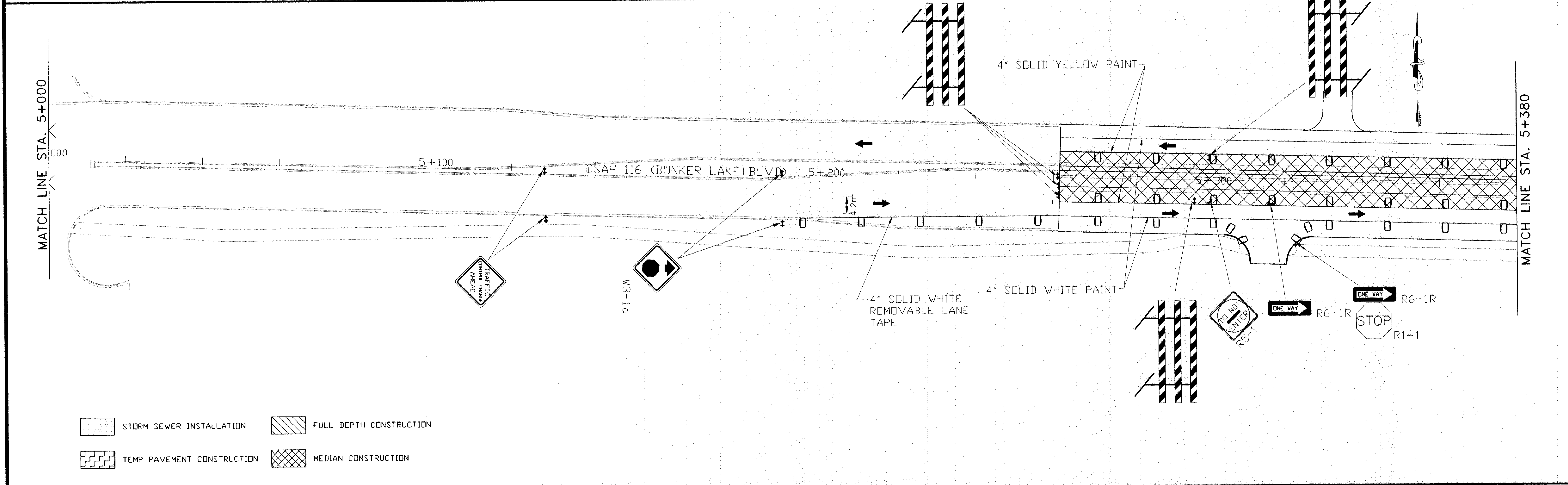
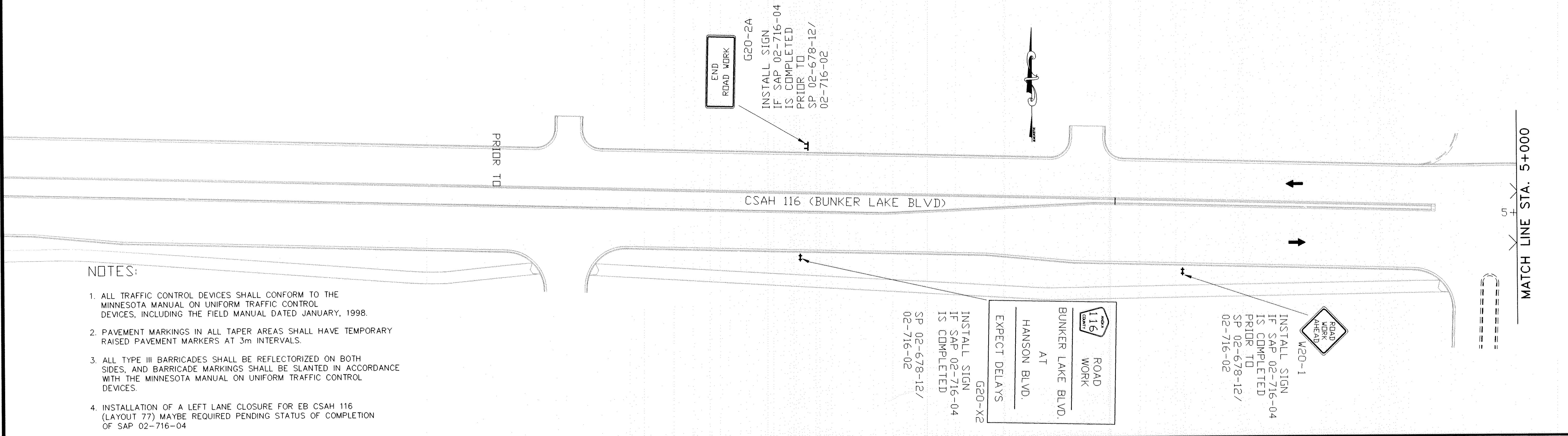

1	6/15/99	RB	JP	LR	CHANGE IN WEST LEG OF INTERSECTION FROM RURAL TO URBAN; COORDINATE STAGING WITH SAP 02-716-04
NO	DATE	BY	CKD	APPR	REVISION



I HEREBY CERTIFY THAT THIS PLAN WAS PREPARED BY ME OR UNDER MY DIRECT SUPERVISION AND THAT I AM A DULY REGISTERED PROFESSIONAL ENGINEER UNDER THE LAWS OF THE STATE OF MINNESOTA.

DATE _____ REG. NO. _____

DRAWN BY _____ DATE _____
 DESIGN BY _____ DATE _____
 CHECKED BY _____ DATE _____

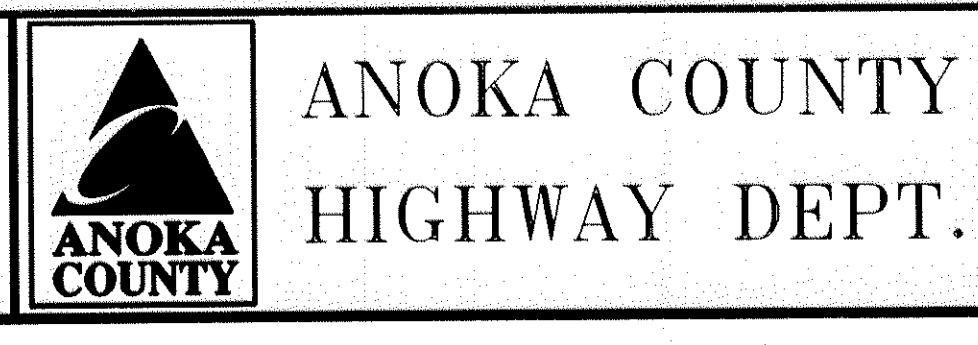

STATE PROJ. NO. 02-678-12/02-716-02
 STATE AID PROJECT NO. _____
 STATE AID PROJECT NO. _____
 COUNTY PROJECT NO. _____

STAGE 4
 BUNKER LAKE BLVD
 C.S.A.H. 78
 Sheet 57 of 59 Sheets

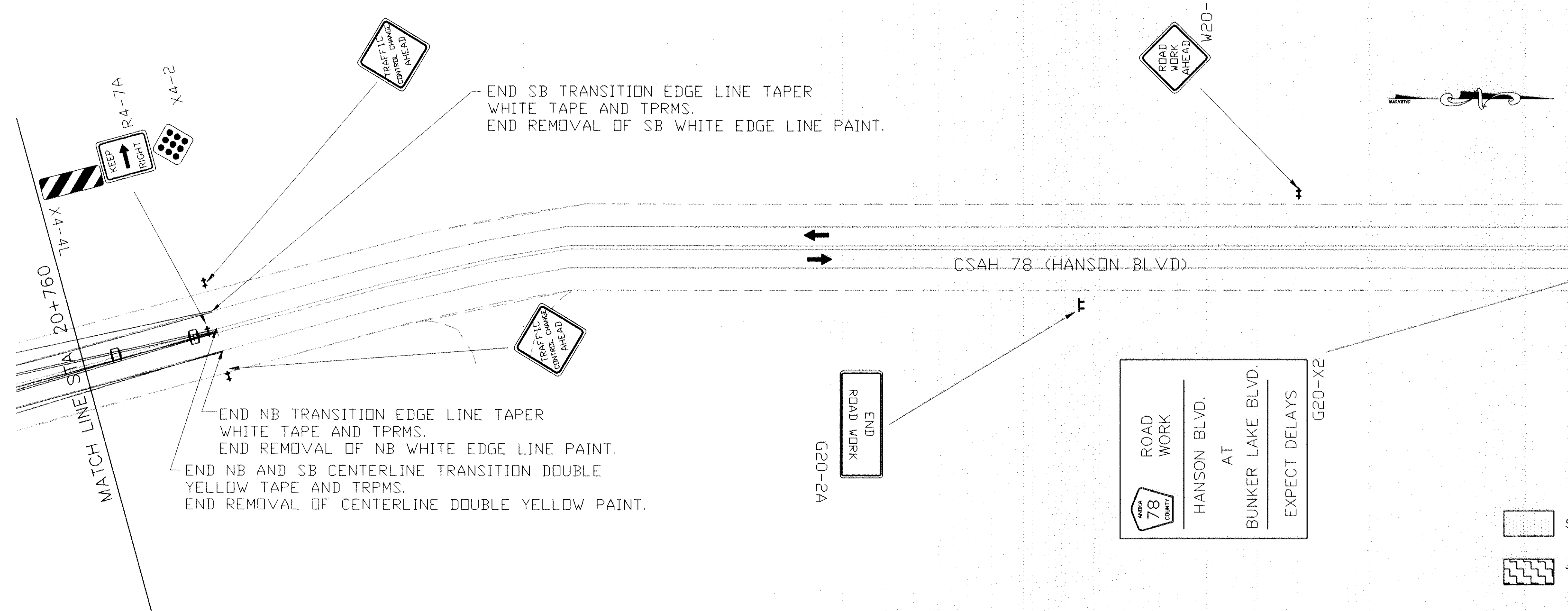
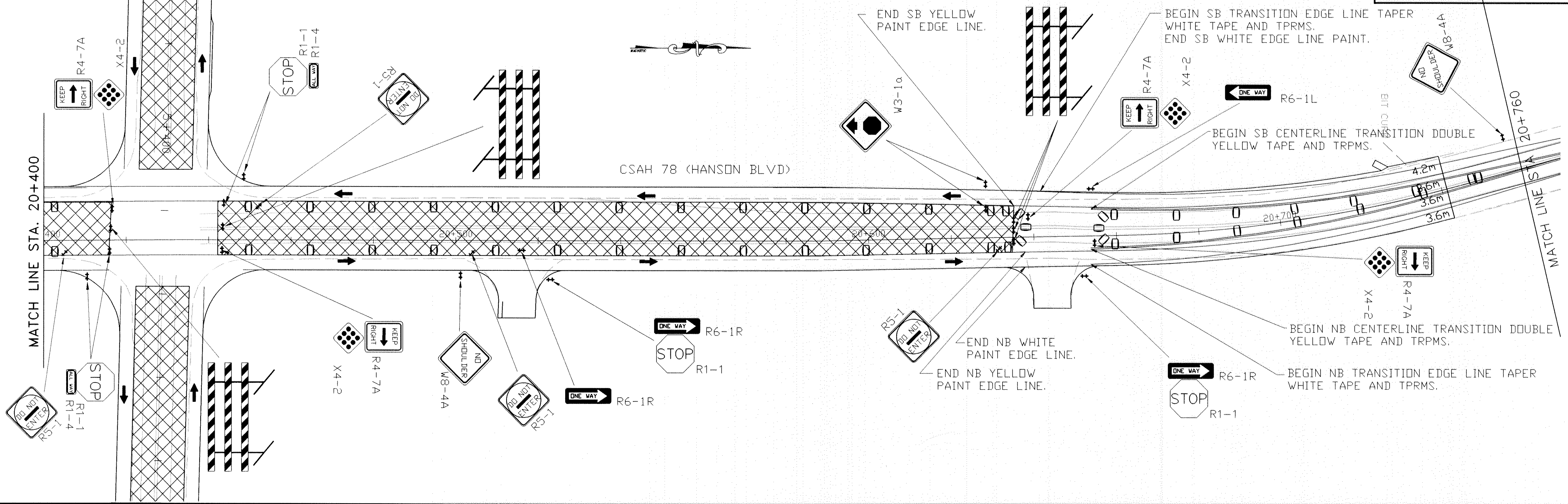

- NOTES:**
1. ALL TRAFFIC CONTROL DEVICES SHALL CONFORM TO THE MINNESOTA MANUAL ON UNIFORM TRAFFIC CONTROL DEVICES, INCLUDING THE FIELD MANUAL DATED JANUARY, 1998.
 2. PAVEMENT MARKINGS IN ALL TAPER AREAS SHALL HAVE TEMPORARY RAISED PAVEMENT MARKERS AT 3m INTERVALS.
 3. ALL TYPE III BARRICADES SHALL BE REFLECTORIZED ON BOTH SIDES, AND BARRICADE MARKINGS SHALL BE SLANTED IN ACCORDANCE WITH THE MINNESOTA MANUAL ON UNIFORM TRAFFIC CONTROL DEVICES.

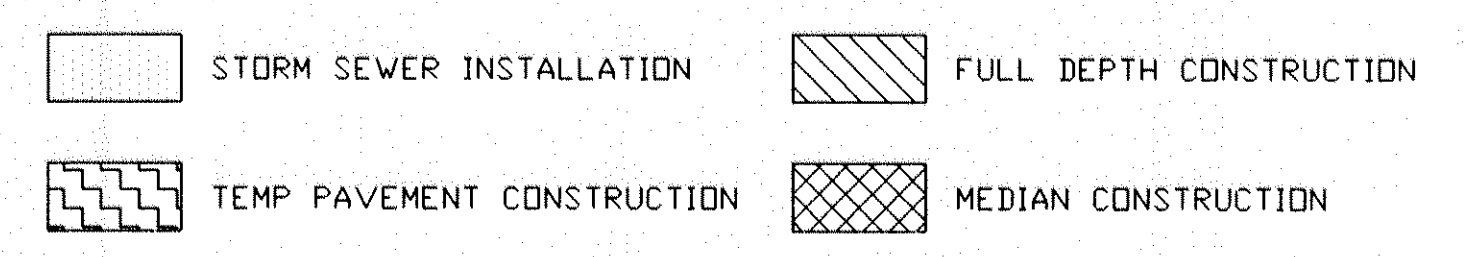

NO	DATE	BY	CKD	APPR	REVISION

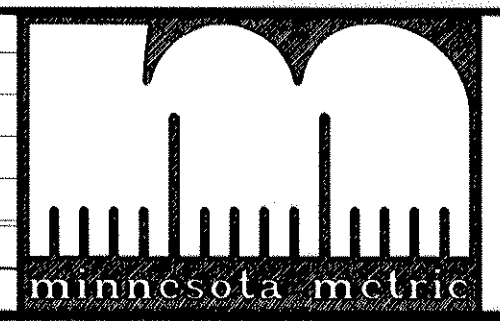

I HEREBY CERTIFY THAT THIS PLAN WAS PREPARED BY ME OR UNDER MY DIRECT SUPERVISION AND THAT I AM A DULY REGISTERED PROFESSIONAL ENGINEER UNDER THE LAWS OF THE STATE OF MINNESOTA.

DATE _____ REG. NO. _____

DRAWN BY _____ DATE _____
 DESIGN BY _____ DATE _____
 CHECKED BY _____ DATE _____

ANOKA COUNTY HIGHWAY DEPT.

ROAD WORK AT BUNKER LAKE BLVD. EXPECT DELAYS

STATE PROJ. NO. 02-678-12/02-716-02
 STATE AID PROJECT NO. _____
 STATE AID PROJECT NO. _____
 COUNTY PROJECT NO. _____

STAGE 4
 HANSON BLVD
 C.S.A.H. 78

Sheet 56 of 59 Sheets

NOTES:

1. ALL TRAFFIC CONTROL DEVICES SHALL CONFORM TO THE MINNESOTA MANUAL ON UNIFORM TRAFFIC CONTROL DEVICES, INCLUDING THE FIELD MANUAL DATED JANUARY, 1998.
2. PAVEMENT MARKINGS IN ALL TAPER AREAS SHALL HAVE TEMPORARY RAISED PAVEMENT MARKERS AT 3m INTERVALS.
3. ALL TYPE III BARRICADES SHALL BE REFLECTORIZED ON BOTH SIDES, AND BARRICADE MARKINGS SHALL BE SLANTED IN ACCORDANCE WITH THE MINNESOTA MANUAL ON UNIFORM TRAFFIC CONTROL DEVICES.

END SB TRANSITION EDGE LINE TAPER WHITE TAPE AND TRPMS.
BEGIN SB WHITE EDGE LINE PAINT.

END SB CENTERLINE TRANSITION DOUBLE YELLOW TAPE AND TRPMS.
BEGIN SB CENTERLINE DOUBLE YELLOW PAINT.

BEGIN SB CENTERLINE TRANSITION DOUBLE YELLOW TAPE AND TRPMS.

BEGIN SB TRANSITION EDGE LINE TAPER WHITE TAPE AND TRPMS.
BEGIN REMOVAL OF STAGE 3 SB WHITE EDGE LINE TAPE.

END REMOVAL OF STAGE 3 SB WHITE EDGE LINE TAPE.

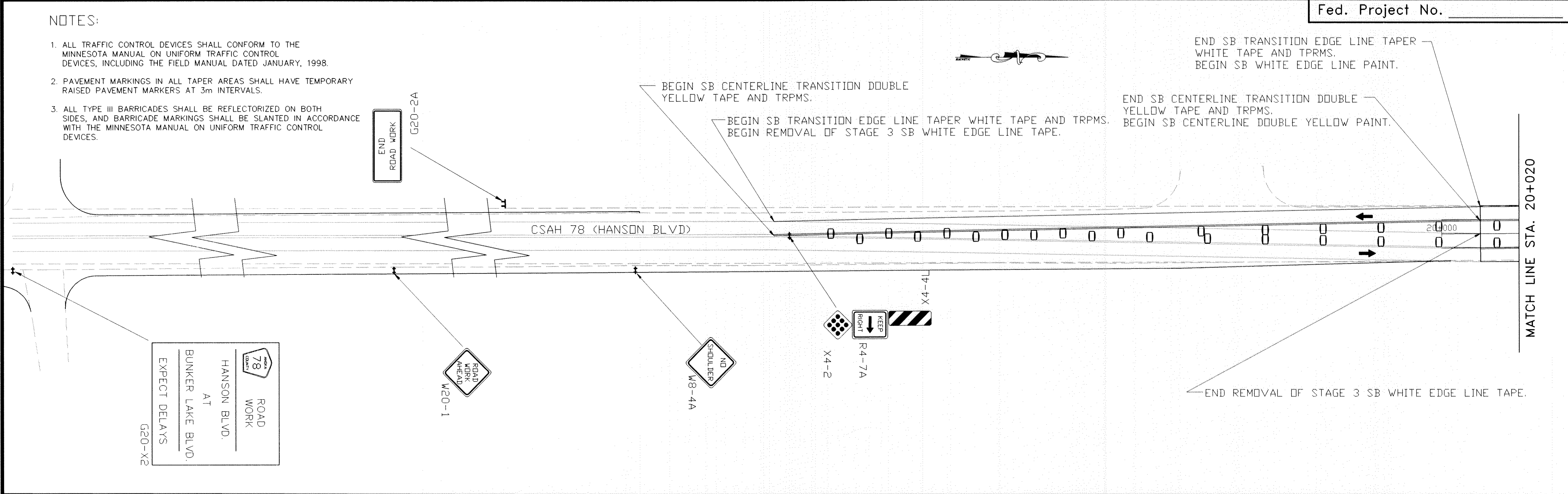

MATCH LINE STA. 20+020

END SB CENTERLINE DOUBLE YELLOW PAINT.
BEGIN SB EDGE LINE YELLOW PAINT.

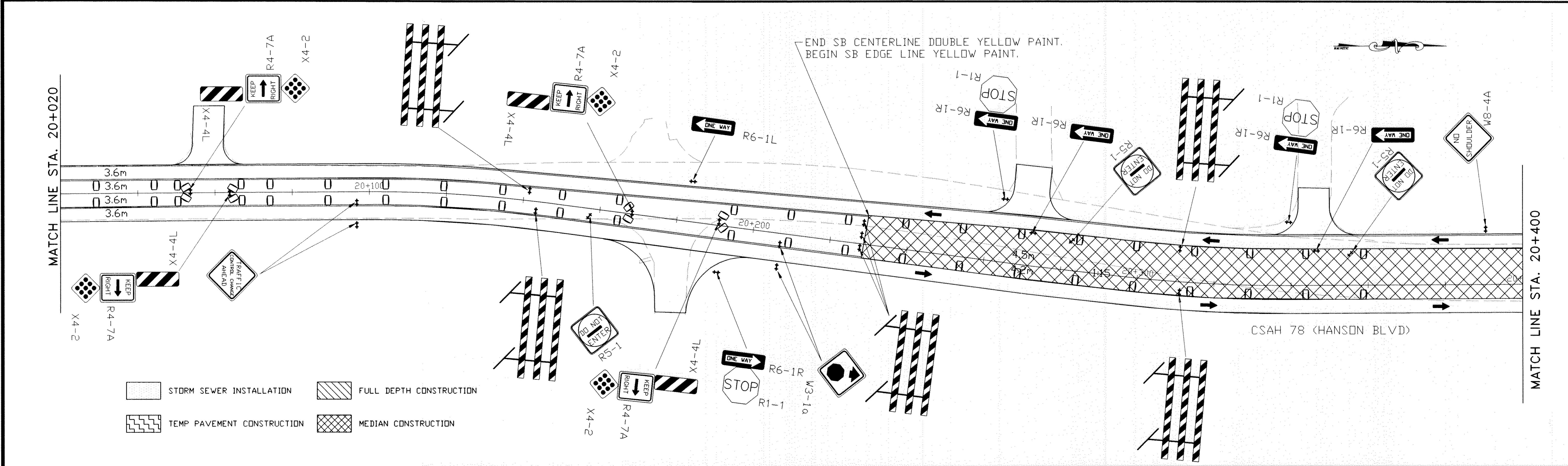

MATCH LINE STA. 20+400

- STORM SEWER INSTALLATION
- FULL DEPTH CONSTRUCTION
- TEMP PAVEMENT CONSTRUCTION
- MEDIAN CONSTRUCTION

NO	DATE	BY	CKD	APPR	REVISION

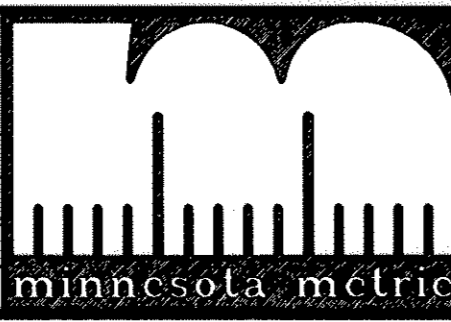

I HEREBY CERTIFY THAT THIS PLAN WAS PREPARED BY ME OR UNDER MY DIRECT SUPERVISION AND THAT I AM A DULY REGISTERED PROFESSIONAL ENGINEER UNDER THE LAWS OF THE STATE OF MINNESOTA.

DATE _____ REG. NO. _____

DRAWN BY _____ DATE _____
 DESIGN BY _____ DATE _____
 CHECKED BY _____ DATE _____

ANOKA COUNTY
HIGHWAY DEPT.

STATE PROJ. NO. 02-678-12/02-716-02
 STATE AID PROJECT NO. _____
 STATE AID PROJECT NO. _____
 COUNTY PROJECT NO. _____

STAGE 4
 HANSON BLVD
 C.S.A.H. 78
 Sheet 55 of 59 Sheets

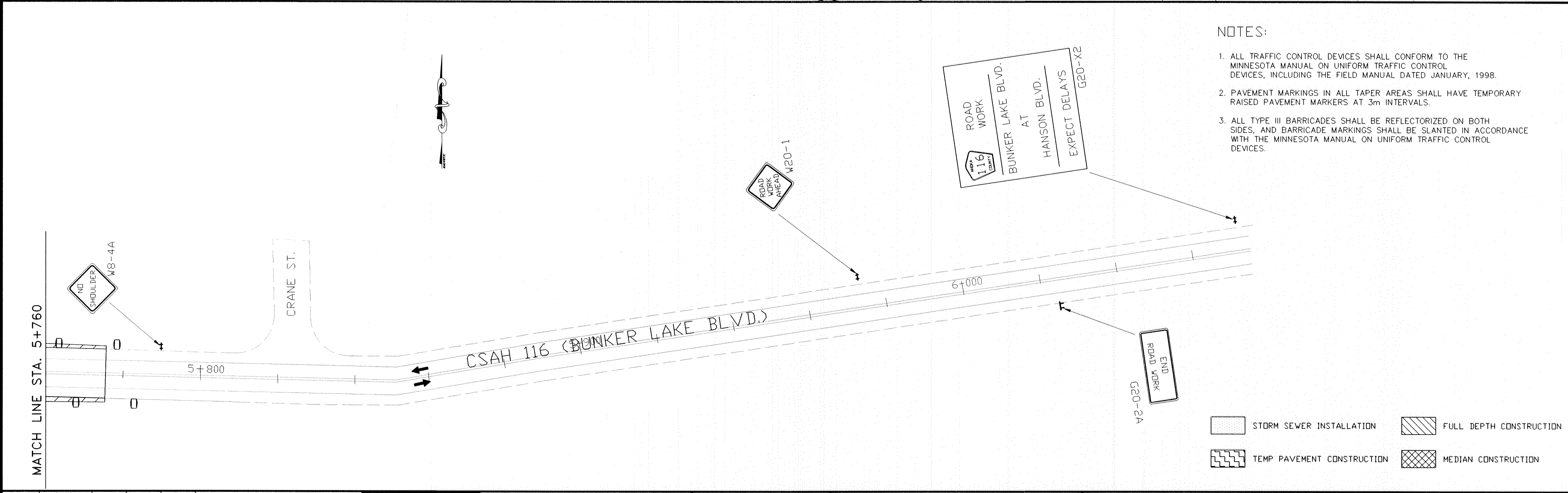
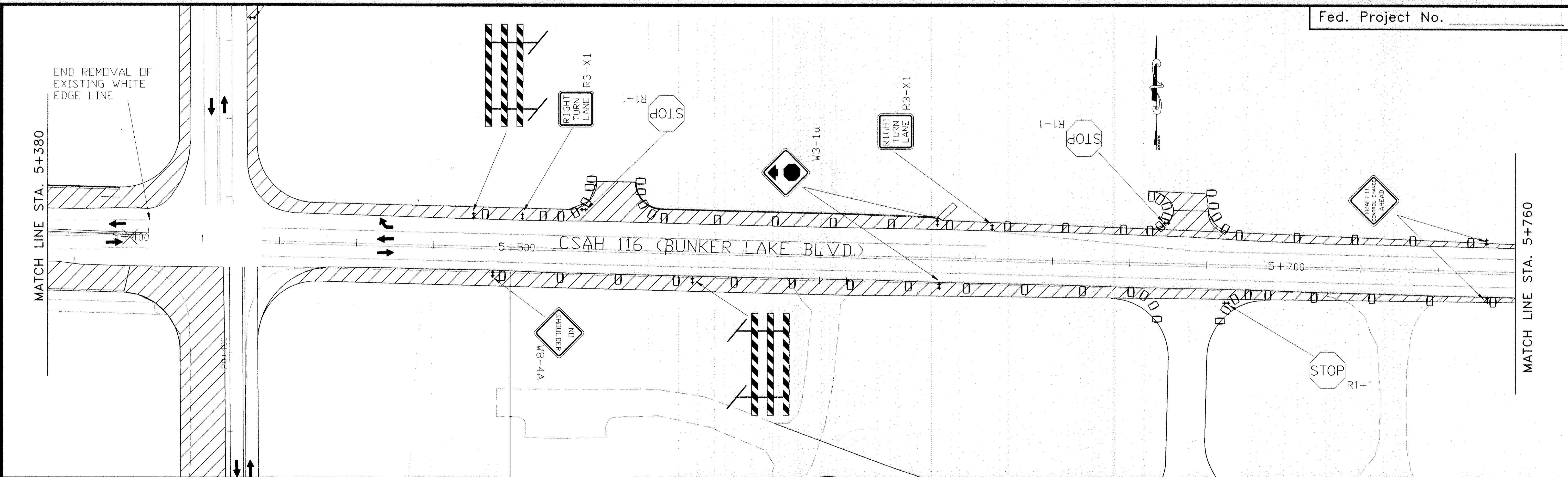

- NOTES:
1. ALL TRAFFIC CONTROL DEVICES SHALL CONFORM TO THE MINNESOTA MANUAL ON UNIFORM TRAFFIC CONTROL DEVICES, INCLUDING THE FIELD MANUAL DATED JANUARY, 1998.
 2. PAVEMENT MARKINGS IN ALL TAPER AREAS SHALL HAVE TEMPORARY RAISED PAVEMENT MARKERS AT 3m INTERVALS.
 3. ALL TYPE III BARRICADES SHALL BE REFLECTORIZED ON BOTH SIDES, AND BARRICADE MARKINGS SHALL BE SLANTED IN ACCORDANCE WITH THE MINNESOTA MANUAL ON UNIFORM TRAFFIC CONTROL DEVICES.

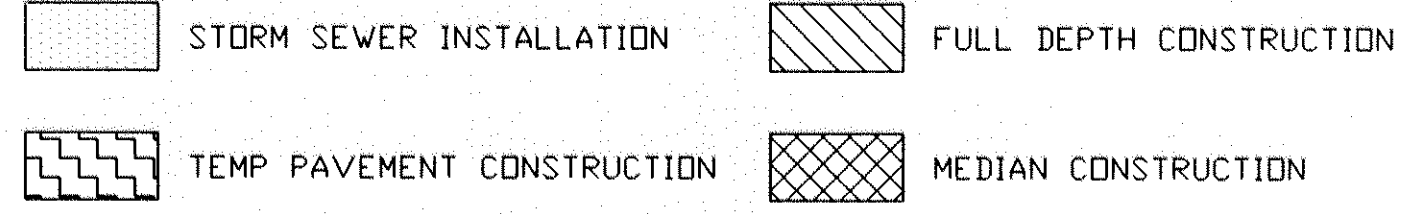

1	6/15/99	RB	JP	LR	REVISED STORM SEWER CROSSING COORDINATE STAGING WITH SAP 02-716-04
NO	DATE	BY	CKD	APPR	REVISION



I HEREBY CERTIFY THAT THIS PLAN WAS PREPARED BY ME OR UNDER MY DIRECT SUPERVISION AND THAT I AM A DULY REGISTERED PROFESSIONAL ENGINEER UNDER THE LAWS OF THE STATE OF MINNESOTA.

DATE _____ REG. NO. _____

DRAWN BY _____ DATE _____
 DESIGN BY _____ DATE _____
 CHECKED BY _____ DATE _____

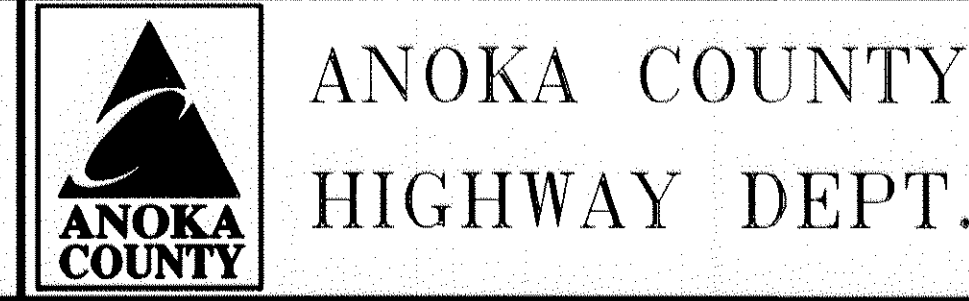

STATE PROJ. NO. 02-678-12/02-716-02
 STATE AID PROJECT NO. _____
 STATE AID PROJECT NO. _____
 COUNTY PROJECT NO. _____

STAGE 3
 BUNKER LAKE BLVD
 C.S.A.H. 78
 Sheet 54 of 59 Sheets

END ROAD WORK
G20-2A
INSTALL SIGN
IF SAP 02-716-04
IS COMPLETED
PRIOR TO
SP 02-678-12/
02-716-02

CSAH 116 (BUNKER LAKE BLVD.)

NOTES:

1. ALL TRAFFIC CONTROL DEVICES SHALL CONFORM TO THE MINNESOTA MANUAL ON UNIFORM TRAFFIC CONTROL DEVICES, INCLUDING THE FIELD MANUAL DATED JANUARY, 1998.
2. PAVEMENT MARKINGS IN ALL TAPER AREAS SHALL HAVE TEMPORARY RAISED PAVEMENT MARKERS AT 3m INTERVALS.
3. ALL TYPE III BARRICADES SHALL BE REFLECTORIZED ON BOTH SIDES, AND BARRICADE MARKINGS SHALL BE SLANTED IN ACCORDANCE WITH THE MINNESOTA MANUAL ON UNIFORM TRAFFIC CONTROL DEVICES.
4. INSTALLATION OF A RIGHT LANE CLOSURE FOR EB CSAH 116 (LAYOUT 76) MAYBE REQUIRED PENDING STATUS OF COMPLETION OF SAP 02-716-04

G20-X2
INSTALL SIGN
IF SAP 02-716-04
IS COMPLETED
PRIOR TO
SP 02-678-12/
02-716-02

BUNKER LAKE BLVD.
AT
HANSON BLVD.
EXPECT DELAYS

ROAD WORK AHEAD
W20-1
INSTALL SIGN
IF SAP 02-716-04
IS COMPLETED
PRIOR TO
SP 02-678-12/
02-716-02

MATCH LINE STA. 5+000

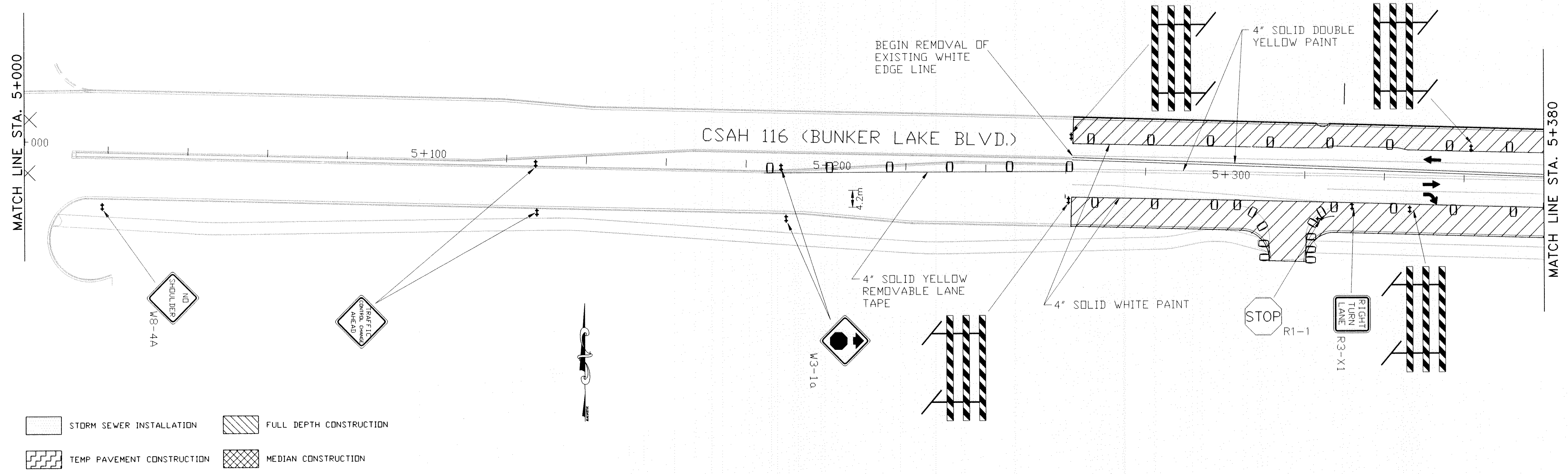

STORM SEWER INSTALLATION FULL DEPTH CONSTRUCTION

TEMP PAVEMENT CONSTRUCTION MEDIAN CONSTRUCTION

1	6/15/99	RB	JP	LR	REVISED STORM SEWER CROSSING COORDINATE STAGING WITH SAP 02-716-04
NO	DATE	BY	CKD	APPR	REVISION

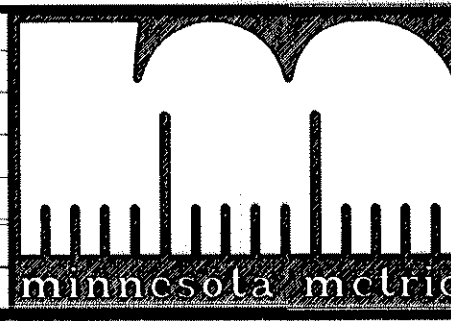

I HEREBY CERTIFY THAT THIS PLAN WAS PREPARED BY ME OR UNDER MY DIRECT SUPERVISION AND THAT I AM A DULY REGISTERED PROFESSIONAL ENGINEER UNDER THE LAWS OF THE STATE OF MINNESOTA.

DATE _____ REG. NO. _____

DRAWN BY _____ DATE _____
DESIGN BY _____ DATE _____
CHECKED BY _____ DATE _____

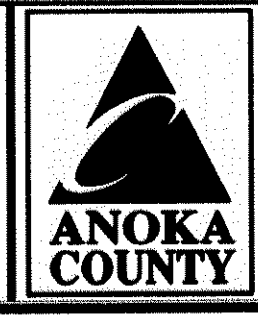

ANOKA COUNTY
HIGHWAY DEPT.

STATE PROJ. NO. 02-678-12/02-716-02
STATE AID PROJECT NO. _____
STATE AID PROJECT NO. _____
COUNTY PROJECT NO. _____

STAGE 3
BUNKER LAKE BLVD
C.S.A.H. 78
Sheet 53 of 59 Sheets

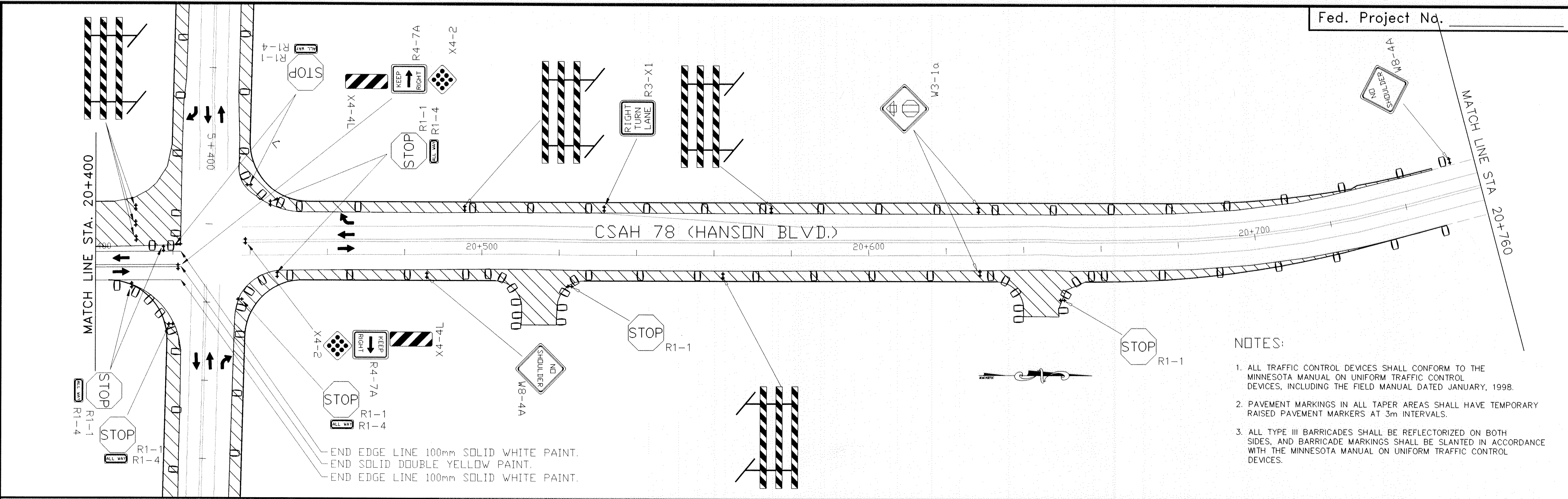

I HEREBY CERTIFY THAT THIS PLAN WAS PREPARED BY ME OR UNDER MY DIRECT SUPERVISION AND THAT I AM A DULY REGISTERED PROFESSIONAL ENGINEER UNDER THE LAWS OF THE STATE OF MINNESOTA.

DATE _____ REG. NO. _____

DRAWN BY _____ DATE _____
 DESIGN BY _____ DATE _____
 CHECKED BY _____ DATE _____

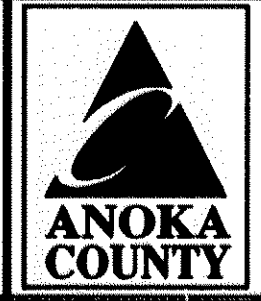

**ANOKA COUNTY
HIGHWAY DEPT.**

STATE PROJ. NO. 02-678-12/02-716-02
 STATE AID PROJECT NO. _____
 STATE AID PROJECT NO. _____
 COUNTY PROJECT NO. _____

STAGE 3
 HANSON BLVD
 C.S.A.H. 78
 Sheet 52 of 59 Sheets

NOTES:

1. ALL TRAFFIC CONTROL DEVICES SHALL CONFORM TO THE MINNESOTA MANUAL ON UNIFORM TRAFFIC CONTROL DEVICES, INCLUDING THE FIELD MANUAL DATED JANUARY, 1998.
2. PAVEMENT MARKINGS IN ALL TAPER AREAS SHALL HAVE TEMPORARY RAISED PAVEMENT MARKERS AT 3m INTERVALS.
3. ALL TYPE III BARRICADES SHALL BE REFLECTORIZED ON BOTH SIDES, AND BARRICADE MARKINGS SHALL BE SLANTED IN ACCORDANCE WITH THE MINNESOTA MANUAL ON UNIFORM TRAFFIC CONTROL DEVICES.

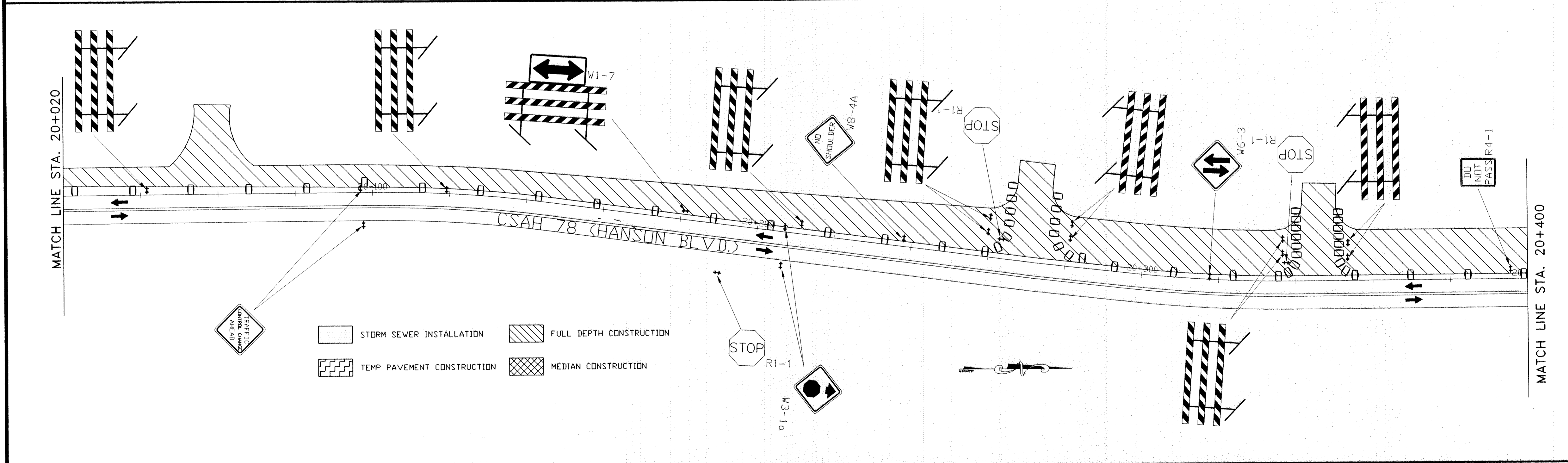
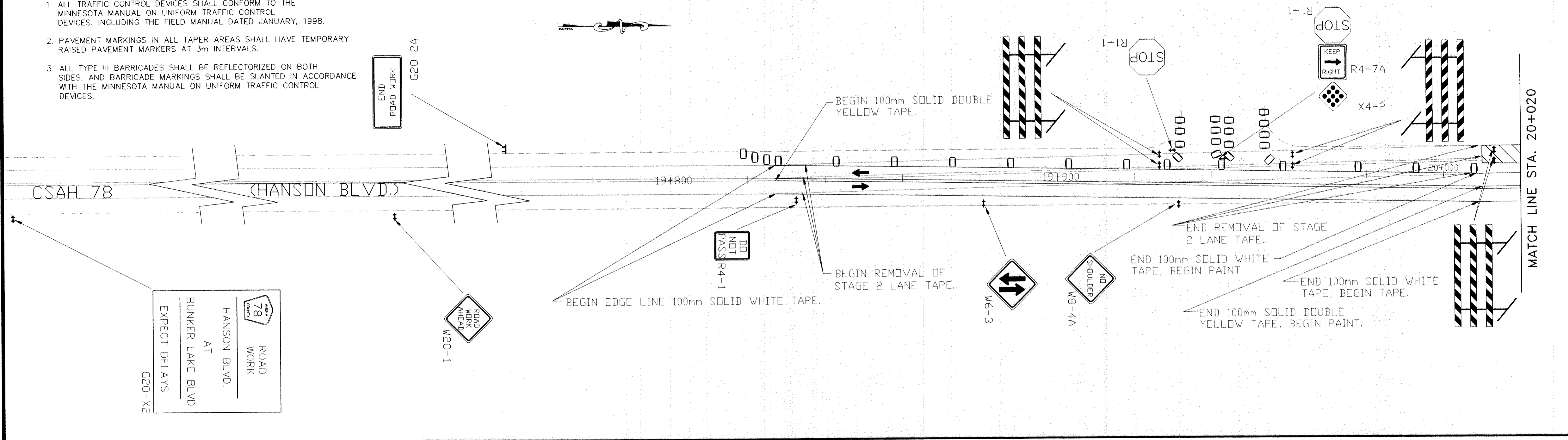

		I HEREBY CERTIFY THAT THIS PLAN WAS PREPARED BY ME OR UNDER MY DIRECT SUPERVISION AND THAT I AM A DULY REGISTERED PROFESSIONAL ENGINEER UNDER THE LAWS OF THE STATE OF MINNESOTA. DATE _____ REG. NO. _____	DRAWN BY _____ DATE _____ DESIGN BY _____ DATE _____ CHECKED BY _____ DATE _____	 ANOKA COUNTY HIGHWAY DEPT.	STATE PROJ. NO. 02-678-12/02-716-02 STATE AID PROJECT NO. _____ STATE AID PROJECT NO. _____ COUNTY PROJECT NO. _____	STAGE 3 HANSON BLVD C.S.A.H. 78 Sheet 51 of 59 Sheets
NO DATE BY CKD APPR REVISION NAME:						

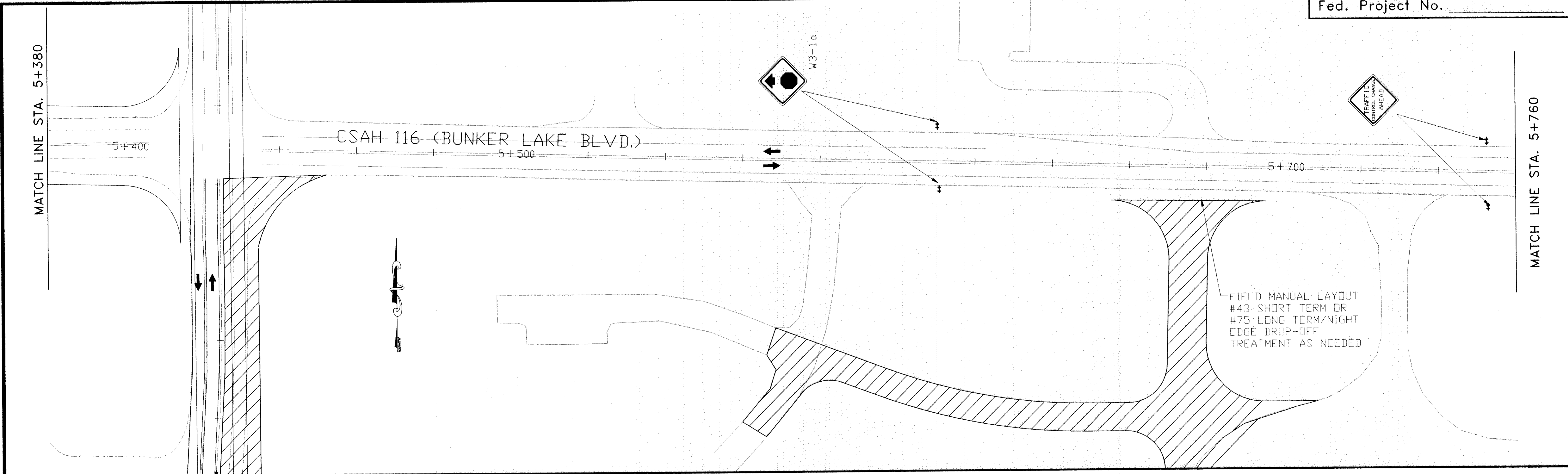

NOTES:

1. ALL TRAFFIC CONTROL DEVICES SHALL CONFORM TO THE MINNESOTA MANUAL ON UNIFORM TRAFFIC CONTROL DEVICES, INCLUDING THE FIELD MANUAL DATED JANUARY, 1998.
2. PAVEMENT MARKINGS IN ALL TAPER AREAS SHALL HAVE TEMPORARY RAISED PAVEMENT MARKERS AT 3m INTERVALS.
3. ALL TYPE III BARRICADES SHALL BE REFLECTORIZED ON BOTH SIDES, AND BARRICADE MARKINGS SHALL BE SLANTED IN ACCORDANCE WITH THE MINNESOTA MANUAL ON UNIFORM TRAFFIC CONTROL DEVICES.

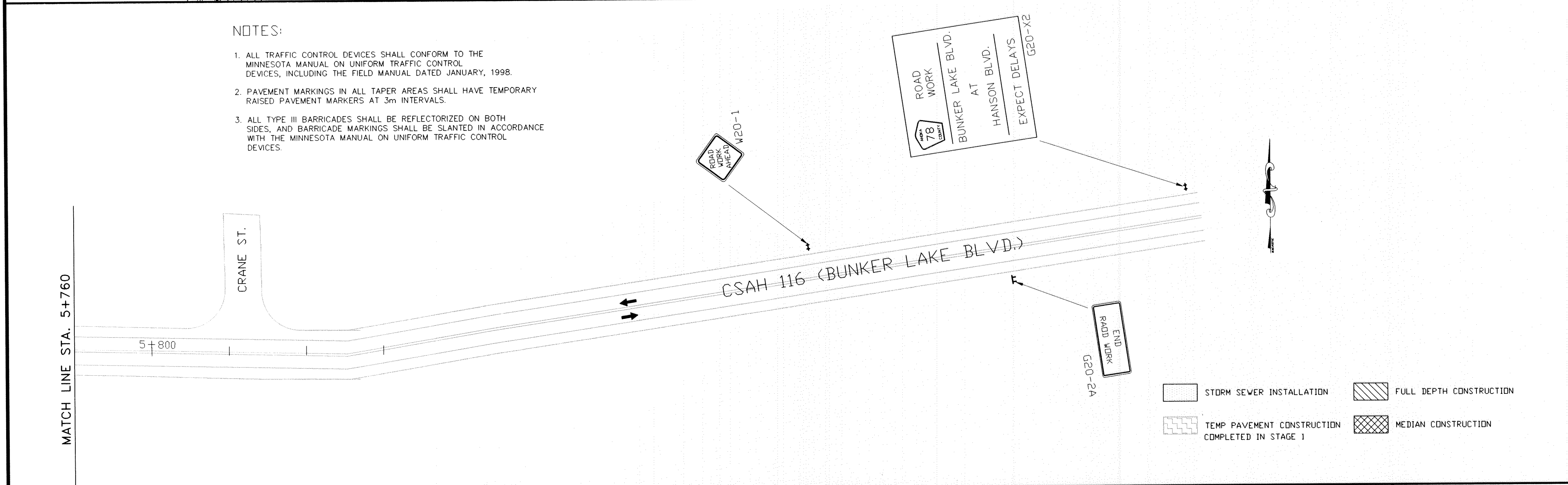

STORM SEWER INSTALLATION	FULL DEPTH CONSTRUCTION
TEMP PAVEMENT CONSTRUCTION COMPLETED IN STAGE 1	MEDIAN CONSTRUCTION

NO	DATE	BY	CKD	APPR	REVISION



I HEREBY CERTIFY THAT THIS PLAN WAS PREPARED BY ME OR UNDER MY DIRECT SUPERVISION AND THAT I AM A DULY REGISTERED PROFESSIONAL ENGINEER UNDER THE LAWS OF THE STATE OF MINNESOTA.

DATE _____ REG. NO. _____

DRAWN BY _____ DATE _____
 DESIGN BY _____ DATE _____
 CHECKED BY _____ DATE _____



ANOKA COUNTY
 HIGHWAY DEPT.

STATE PROJ. NO. 02-678-12/02-716-02
 STATE AID PROJECT NO. _____
 STATE AID PROJECT NO. _____
 COUNTY PROJECT NO. _____

STAGE 2
 BUNKER LAKE BLVD
 C.S.A.H. 78
 Sheet 50 of 59 Sheets

NOTES:

1. ALL TRAFFIC CONTROL DEVICES SHALL CONFORM TO THE MINNESOTA MANUAL ON UNIFORM TRAFFIC CONTROL DEVICES, INCLUDING THE FIELD MANUAL DATED JANUARY, 1998.
2. PAVEMENT MARKINGS IN ALL TAPER AREAS SHALL HAVE TEMPORARY RAISED PAVEMENT MARKERS AT 3m INTERVALS.
3. ALL TYPE III BARRICADES SHALL BE REFLECTORIZED ON BOTH SIDES, AND BARRICADE MARKINGS SHALL BE SLANTED IN ACCORDANCE WITH THE MINNESOTA MANUAL ON UNIFORM TRAFFIC CONTROL DEVICES.

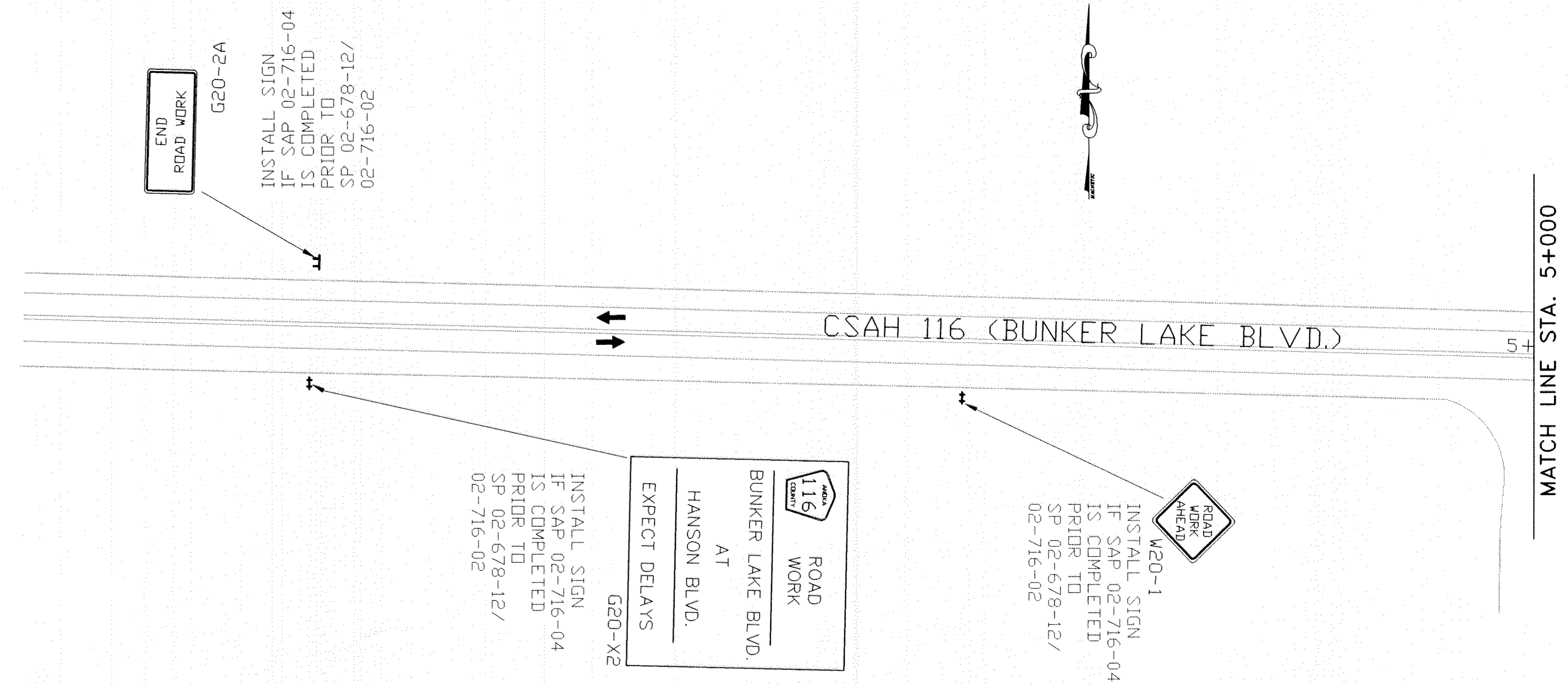

1	6/15/99	RB	JP	LR	REVISED STORM SEWER CROSSING COORDINATE STAGING WITH SAP 02-716-04
NO	DATE	BY	CKD	APPR	REVISION
NAME: F:\0267812\WORK\STAGE2 2-5-98 3:07:59 pm EST					

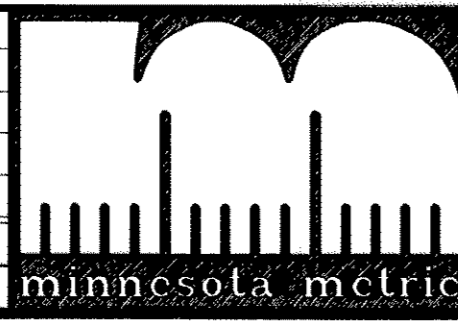

I HEREBY CERTIFY THAT THIS PLAN WAS PREPARED BY ME OR UNDER MY DIRECT SUPERVISION AND THAT I AM A DULY REGISTERED PROFESSIONAL ENGINEER UNDER THE LAWS OF THE STATE OF MINNESOTA.

DATE _____ REG. NO. _____

DRAWN BY _____ DATE _____
 DESIGN BY _____ DATE _____
 CHECKED BY _____ DATE _____



ANOKA COUNTY
HIGHWAY DEPT.

STATE PROJ. NO. 02-678-12/02-716-02
 STATE AID PROJECT NO. _____
 STATE AID PROJECT NO. _____
 COUNTY PROJECT NO. _____

STAGE 2
BUNKER LAKE BLVD
 C.S.A.H. 78
 Sheet 49 of 59 Sheets

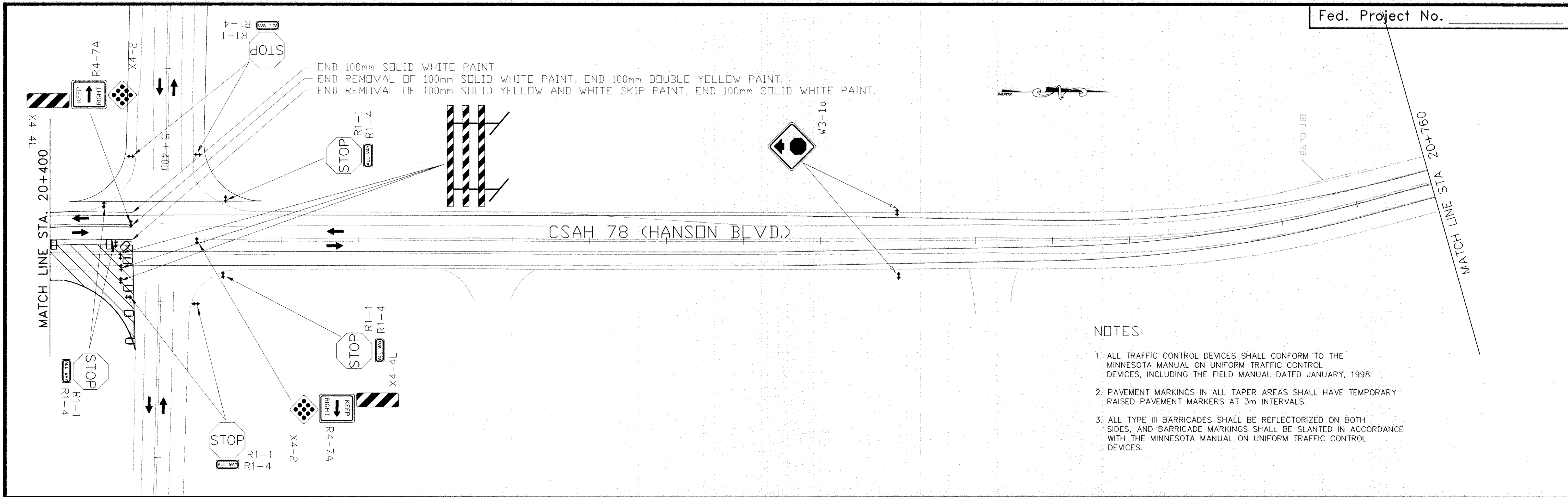

NOTES:

1. ALL TRAFFIC CONTROL DEVICES SHALL CONFORM TO THE MINNESOTA MANUAL ON UNIFORM TRAFFIC CONTROL DEVICES, INCLUDING THE FIELD MANUAL DATED JANUARY, 1998.
2. PAVEMENT MARKINGS IN ALL TAPER AREAS SHALL HAVE TEMPORARY RAISED PAVEMENT MARKERS AT 3m INTERVALS.
3. ALL TYPE III BARRICADES SHALL BE REFLECTORIZED ON BOTH SIDES, AND BARRICADE MARKINGS SHALL BE SLANTED IN ACCORDANCE WITH THE MINNESOTA MANUAL ON UNIFORM TRAFFIC CONTROL DEVICES.

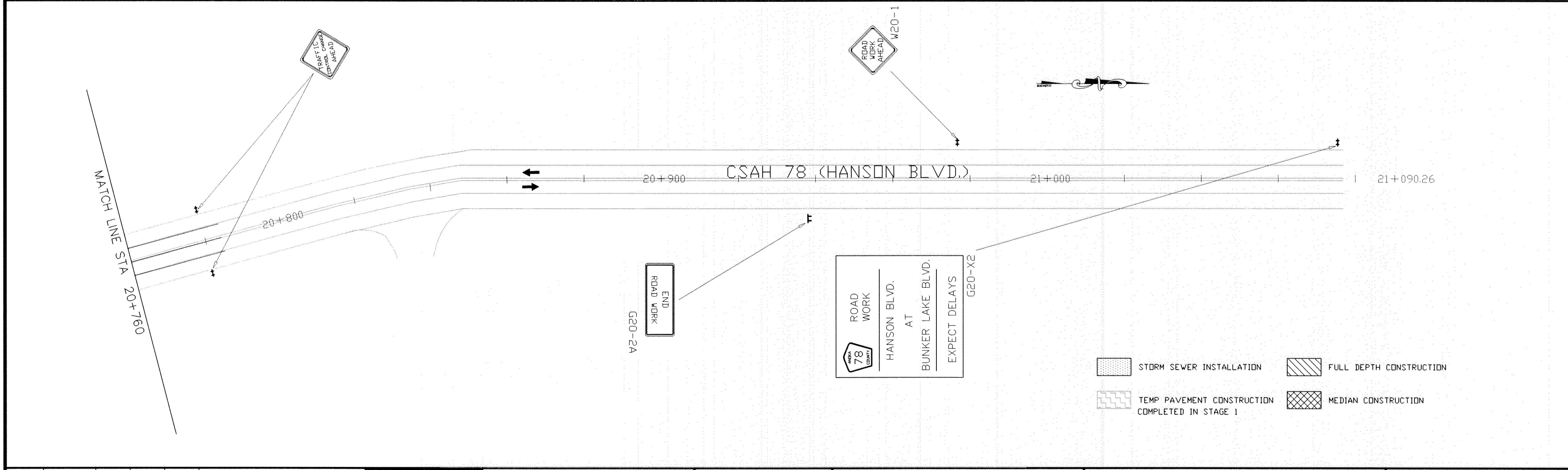

NO	DATE	BY	CKD	APPR	REVISION



I HEREBY CERTIFY THAT THIS PLAN WAS PREPARED BY ME OR UNDER MY DIRECT SUPERVISION AND THAT I AM A DULY REGISTERED PROFESSIONAL ENGINEER UNDER THE LAWS OF THE STATE OF MINNESOTA.

DATE _____ REG. NO. _____

DRAWN BY _____ DATE _____
 DESIGN BY _____ DATE _____
 CHECKED BY _____ DATE _____

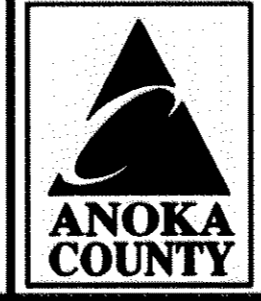

**ANOKA COUNTY
HIGHWAY DEPT.**

STATE PROJ. NO. 02-678-12/02-716-02
 STATE AID PROJECT NO. _____
 STATE AID PROJECT NO. _____
 COUNTY PROJECT NO. _____

STAGE 2
HANSON BLVD
 C.S.A.H. 78

Sheet 48 of 59 Sheets

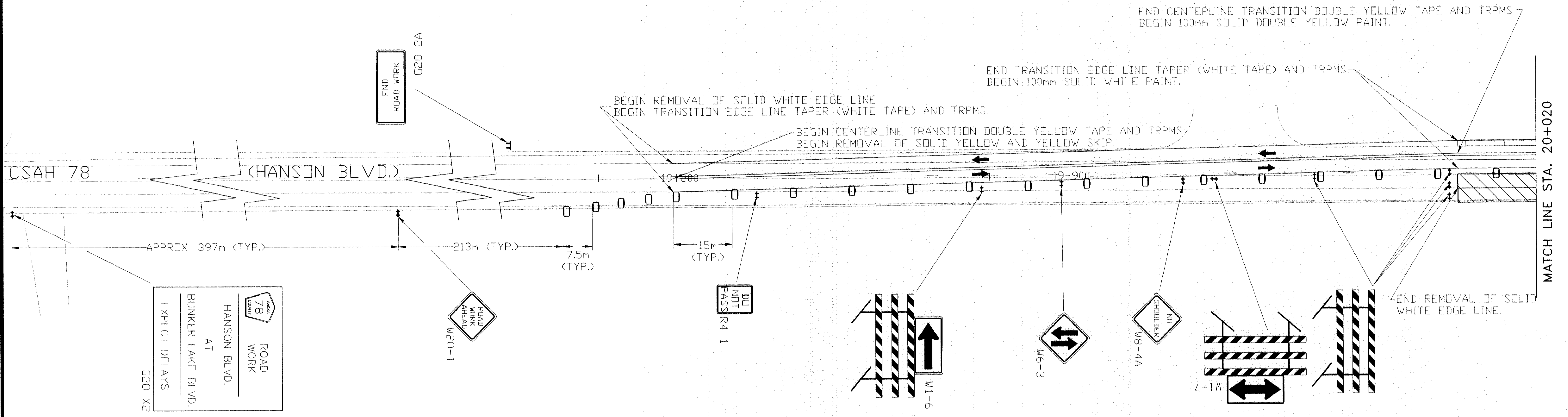

NOTES:

1. ALL TRAFFIC CONTROL DEVICES SHALL CONFORM TO THE MINNESOTA MANUAL ON UNIFORM TRAFFIC CONTROL DEVICES, INCLUDING THE FIELD MANUAL DATED JANUARY, 1998.
2. PAVEMENT MARKINGS IN ALL TAPER AREAS SHALL HAVE TEMPORARY RAISED PAVEMENT MARKERS AT 3m INTERVALS.
3. ALL TYPE III BARRICADES SHALL BE REFLECTORIZED ON BOTH SIDES, AND BARRICADE MARKINGS SHALL BE SLANTED IN ACCORDANCE WITH THE MINNESOTA MANUAL ON UNIFORM TRAFFIC CONTROL DEVICES.

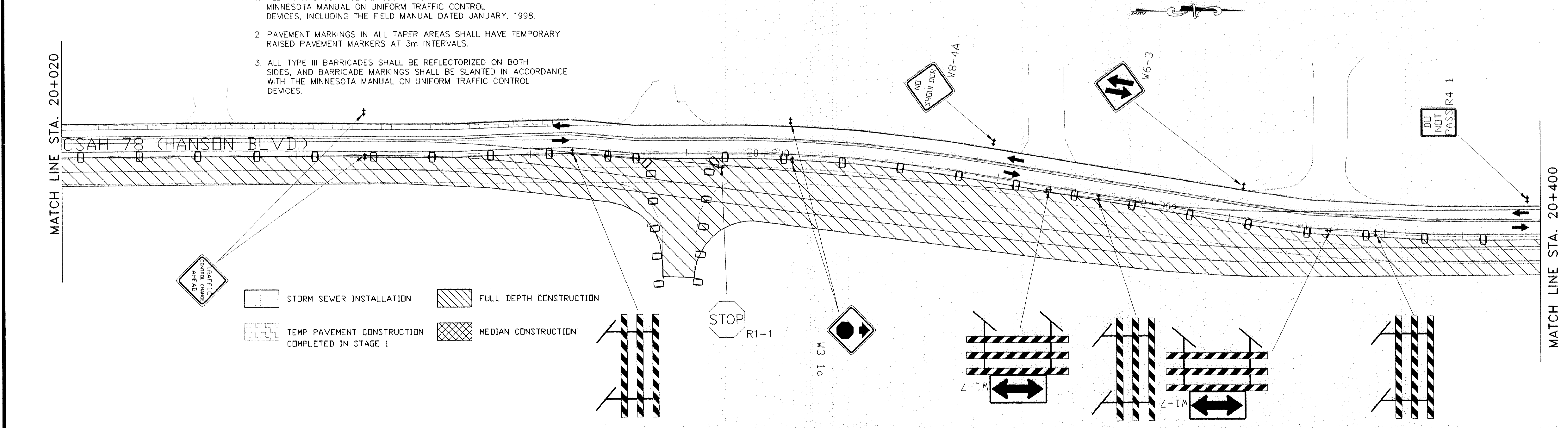

NO	DATE	BY	CKD	APPR	REVISION

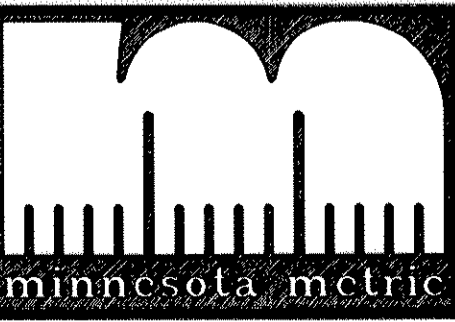

I HEREBY CERTIFY THAT THIS PLAN WAS PREPARED BY ME OR UNDER MY DIRECT SUPERVISION AND THAT I AM A DULY REGISTERED PROFESSIONAL ENGINEER UNDER THE LAWS OF THE STATE OF MINNESOTA.

DATE _____ REG. NO. _____

DRAWN BY _____ DATE _____
 DESIGN BY _____ DATE _____
 CHECKED BY _____ DATE _____

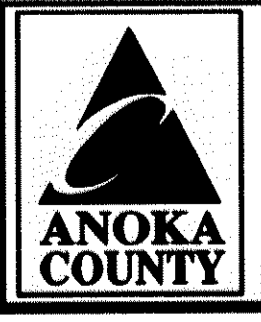

ANOKA COUNTY
 HIGHWAY DEPT.

STATE PROJ. NO. 02-678-12/02-716-02
 STATE AID PROJECT NO. _____
 STATE AID PROJECT NO. _____
 COUNTY PROJECT NO. _____

STAGE 2
 HANSON BLVD
 C.S.A.H. 78
 Sheet 47 of 59 Sheets

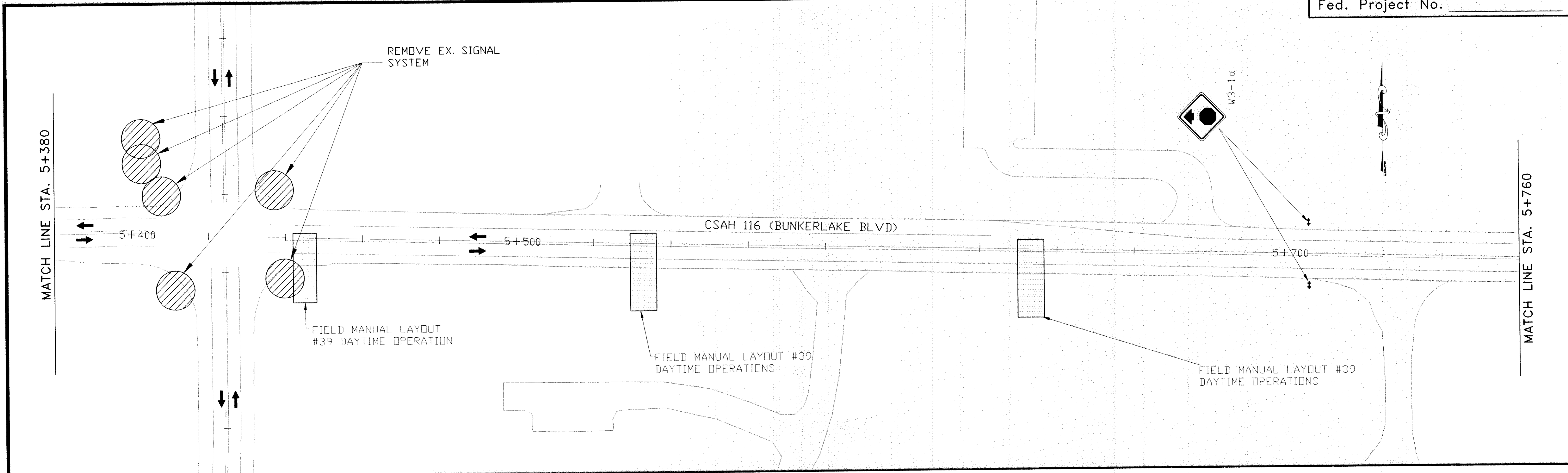

NOTES:

1. ALL TRAFFIC CONTROL DEVICES SHALL CONFORM TO THE MINNESOTA MANUAL ON UNIFORM TRAFFIC CONTROL DEVICES, INCLUDING THE FIELD MANUAL DATED JANUARY, 1998.
2. PAVEMENT MARKINGS IN ALL TAPER AREAS SHALL HAVE TEMPORARY RAISED PAVEMENT MARKERS AT 3m INTERVALS.
3. ALL TYPE III BARRICADES SHALL BE REFLECTORIZED ON BOTH SIDES, AND BARRICADE MARKINGS SHALL BE SLANTED IN ACCORDANCE WITH THE MINNESOTA MANUAL ON UNIFORM TRAFFIC CONTROL DEVICES.

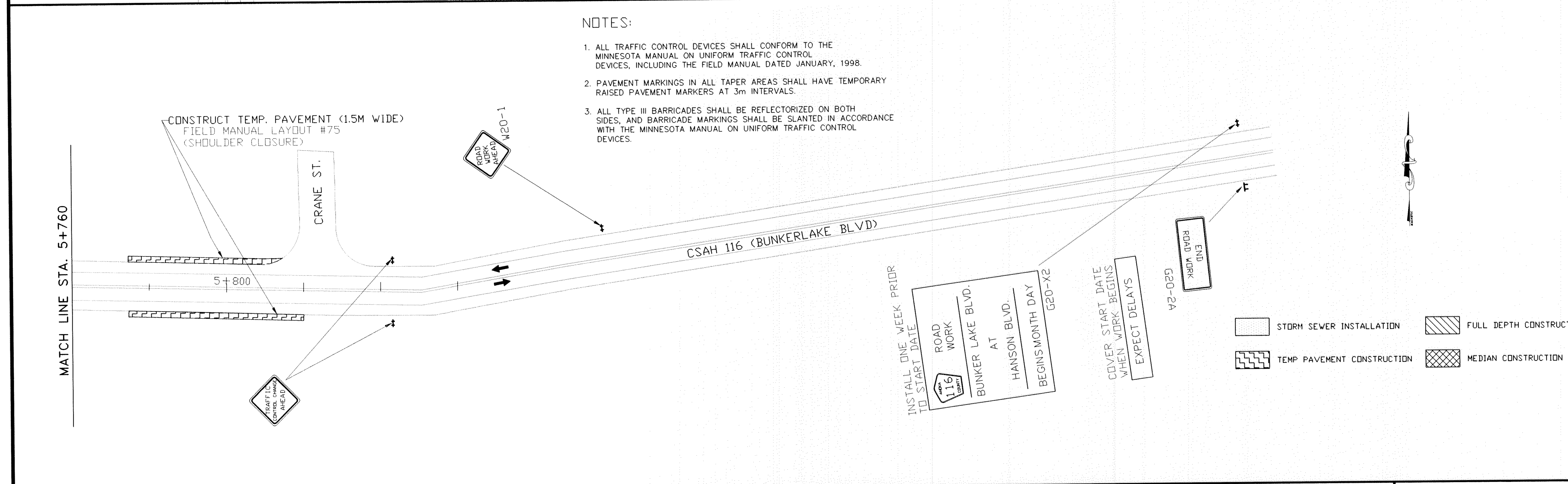

NO	DATE	BY	CKD	APPR	REVISION



I HEREBY CERTIFY THAT THIS PLAN WAS PREPARED BY ME OR UNDER MY DIRECT SUPERVISION AND THAT I AM A DULY REGISTERED PROFESSIONAL ENGINEER UNDER THE LAWS OF THE STATE OF MINNESOTA.

DATE _____ REG. NO. _____

DRAWN BY _____ DATE _____
 DESIGN BY _____ DATE _____
 CHECKED BY _____ DATE _____

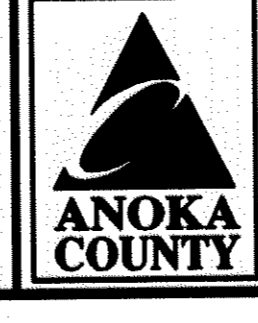

ANOKA COUNTY
 HIGHWAY DEPT.

STATE PROJ. NO. 02-678-12/02-716-02
 STATE AID PROJECT NO. _____
 STATE AID PROJECT NO. _____
 COUNTY PROJECT NO. _____

STAGE 1
 BUNKER LAKE BLVD
 C.S.A.H. 78
 Sheet 46 of 59 Sheets

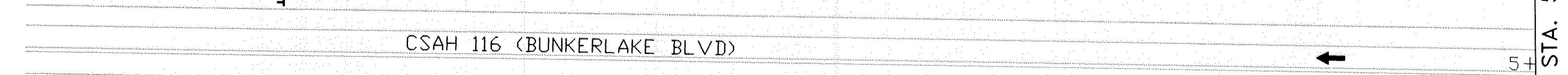

END ROAD WORK
G20-2A
INSTALL SIGN
IF SAP 02-716-04
IS COMPLETED
PRIOR TO
SP 02-678-12/
02-716-02

INSTALL SIGN
IF SAP 02-716-04
IS COMPLETED
PRIOR TO
SP 02-678-12/
02-716-02

COVER START DATE
WHEN WORK BEGINS
EXPECT DELAYS

INSTALL ONE WEEK PRIOR
TO START DATE
ROAD WORK
116
BUNKER LAKE BLVD.
AT
HANSON BLVD.
BEGINS MONTH DAY
G20-X2

INSTALL SIGN
IF SAP 02-716-04
IS COMPLETED
PRIOR TO
SP 02-678-12/
02-716-02

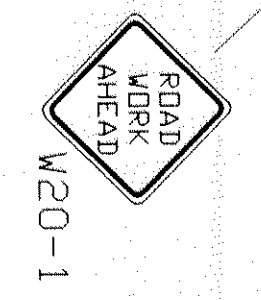

NOTES:

1. ALL TRAFFIC CONTROL DEVICES SHALL CONFORM TO THE MINNESOTA MANUAL ON UNIFORM TRAFFIC CONTROL DEVICES, INCLUDING THE FIELD MANUAL DATED JANUARY, 1998.
2. PAVEMENT MARKINGS IN ALL TAPER AREAS SHALL HAVE TEMPORARY RAISED PAVEMENT MARKERS AT 3m INTERVALS.
3. ALL TYPE III BARRICADES SHALL BE REFLECTORIZED ON BOTH SIDES, AND BARRICADE MARKINGS SHALL BE SLANTED IN ACCORDANCE WITH THE MINNESOTA MANUAL ON UNIFORM TRAFFIC CONTROL DEVICES.

MATCH LINE STA. 5+000

MATCH LINE STA. 5+000

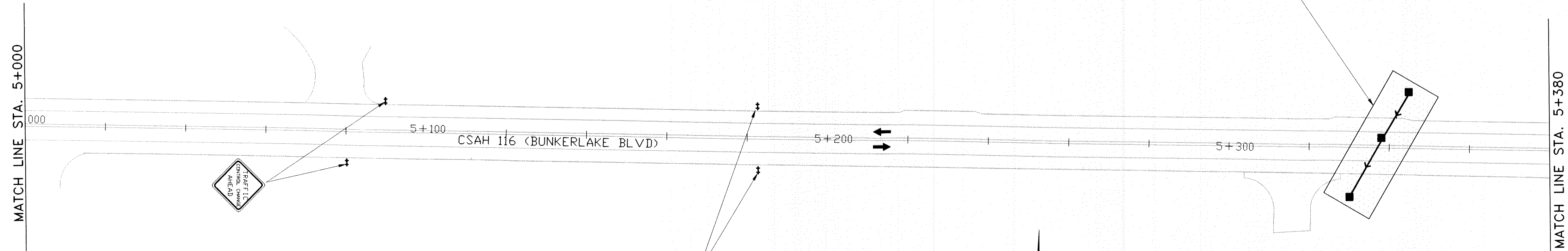

FIELD MANUAL LAYOUT #39
DAYTIME OPERATIONS

MATCH LINE STA. 5+380

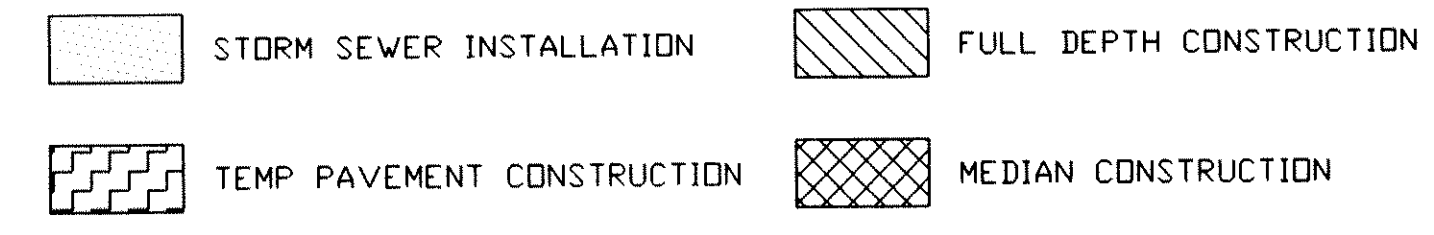

1	6/15/99	RB	JP	LR	REVISED STORM SEWER CROSSING COORDINATE STAGING WITH SAP 02-716-04
NO	DATE	BY	CKD	APPR	REVISION
NAME: stage1REV.dwg 7799 24638					



I HEREBY CERTIFY THAT THIS PLAN WAS PREPARED BY ME OR UNDER MY DIRECT SUPERVISION AND THAT I AM A DULY REGISTERED PROFESSIONAL ENGINEER UNDER THE LAWS OF THE STATE OF MINNESOTA.
DATE _____ REG. NO. _____

DRAWN BY _____ DATE _____
DESIGN BY _____ DATE _____
CHECKED BY _____ DATE _____

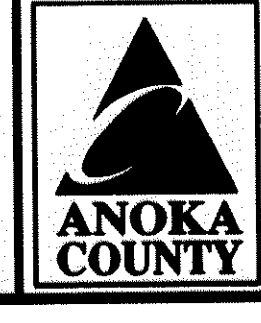

ANOKA COUNTY
HIGHWAY DEPT.

STATE PROJ. NO. 02-678-12/02-716-02
STATE AID PROJECT NO. _____
STATE AID PROJECT NO. _____
COUNTY PROJECT NO. _____

STAGE 1
BUNKER LAKE BLVD
C.S.A.H. 78
Sheet 45 of 59 Sheets

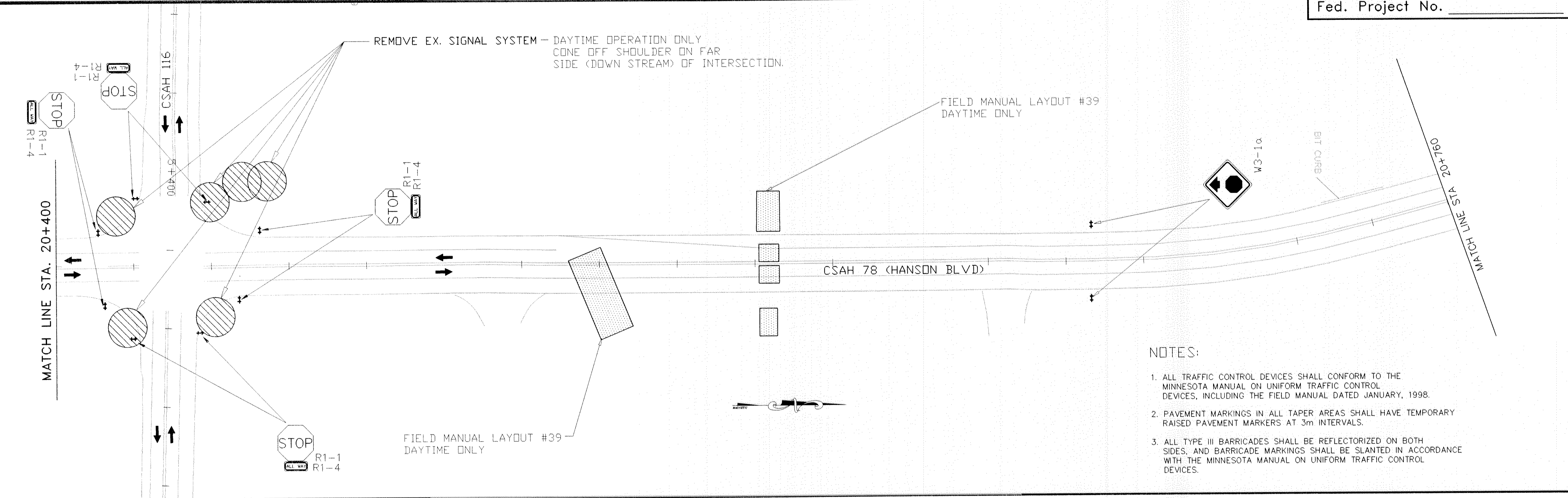

- NOTES:
1. ALL TRAFFIC CONTROL DEVICES SHALL CONFORM TO THE MINNESOTA MANUAL ON UNIFORM TRAFFIC CONTROL DEVICES, INCLUDING THE FIELD MANUAL DATED JANUARY, 1998.
 2. PAVEMENT MARKINGS IN ALL TAPER AREAS SHALL HAVE TEMPORARY RAISED PAVEMENT MARKERS AT 3m INTERVALS.
 3. ALL TYPE III BARRICADES SHALL BE REFLECTORIZED ON BOTH SIDES, AND BARRICADE MARKINGS SHALL BE SLANTED IN ACCORDANCE WITH THE MINNESOTA MANUAL ON UNIFORM TRAFFIC CONTROL DEVICES.

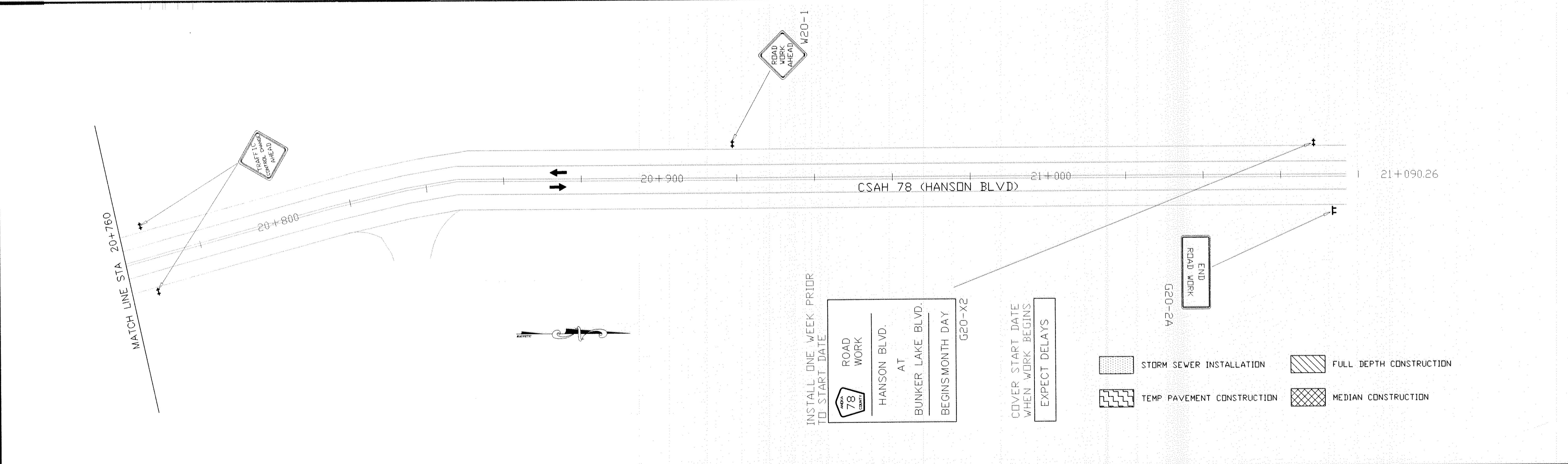

NO	DATE	BY	CKD	APPR	REVISION

I HEREBY CERTIFY THAT THIS PLAN WAS PREPARED BY ME OR UNDER MY DIRECT SUPERVISION AND THAT I AM A DULY REGISTERED PROFESSIONAL ENGINEER UNDER THE LAWS OF THE STATE OF MINNESOTA.

DATE _____ REG. NO. _____

DRAWN BY _____ DATE _____
 DESIGN BY _____ DATE _____
 CHECKED BY _____ DATE _____

ANOKA COUNTY
HIGHWAY DEPT.

STATE PROJ. NO. 02-678-12/02-716-02
 STATE AID PROJECT NO. _____
 STATE AID PROJECT NO. _____
 COUNTY PROJECT NO. _____

NOTES:

1. ALL TRAFFIC CONTROL DEVICES SHALL CONFORM TO THE MINNESOTA MANUAL ON UNIFORM TRAFFIC CONTROL DEVICES, INCLUDING THE FIELD MANUAL DATED JANUARY, 1998.
2. PAVEMENT MARKINGS IN ALL TAPER AREAS SHALL HAVE TEMPORARY RAISED PAVEMENT MARKERS AT 3m INTERVALS.
3. ALL TYPE III BARRICADES SHALL BE REFLECTORIZED ON BOTH SIDES, AND BARRICADE MARKINGS SHALL BE SLANTED IN ACCORDANCE WITH THE MINNESOTA MANUAL ON UNIFORM TRAFFIC CONTROL DEVICES.

COVER START DATE WHEN WORK BEGINS EXPECT DELAYS

INSTALL ONE WEEK PRIOR TO START DATE

ROAD WORK AT HANSON BLVD. BUNKER LAKE BLVD. BEGINS MONTH DAY G20-X2

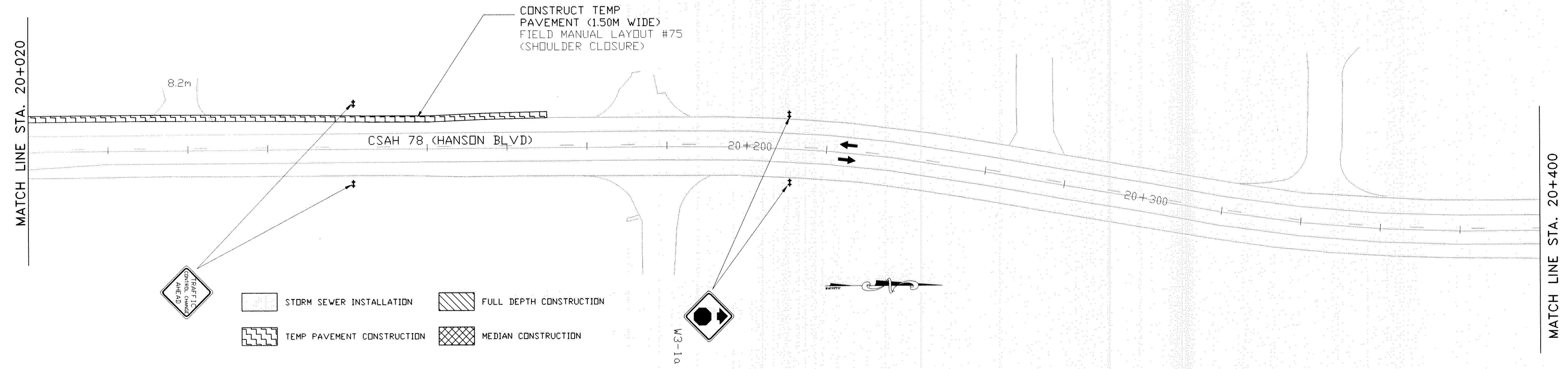
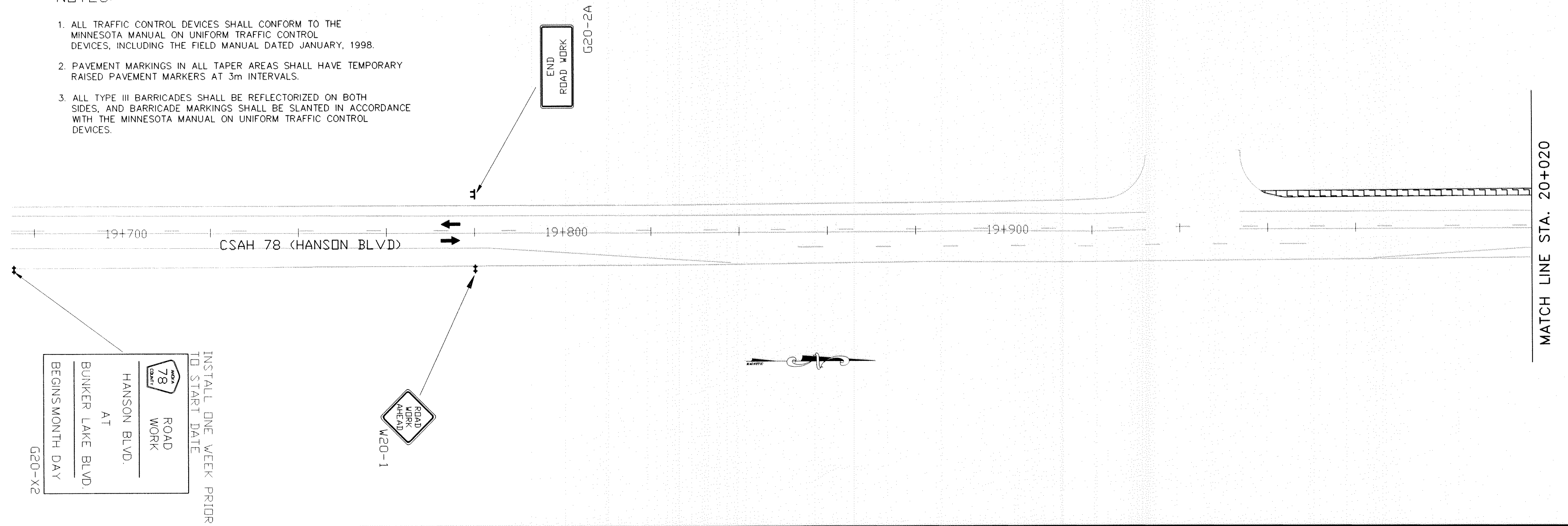

NO	DATE	BY	CKD	APPR	REVISION



I HEREBY CERTIFY THAT THIS PLAN WAS PREPARED BY ME OR UNDER MY DIRECT SUPERVISION AND THAT I AM A DULY REGISTERED PROFESSIONAL ENGINEER UNDER THE LAWS OF THE STATE OF MINNESOTA.

DATE _____ REG. NO. _____

DRAWN BY _____ DATE _____

DESIGN BY _____ DATE _____

CHECKED BY _____ DATE _____

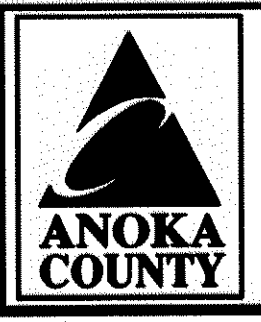

ANOKA COUNTY HIGHWAY DEPT.

STATE PROJ. NO. 02-678-12/02-716-02

STATE AID PROJECT NO. _____

STATE AID PROJECT NO. _____

COUNTY PROJECT NO. _____

STAGE 1 HANSON BLVD C.S.A.H. 78

Sheet 43 of 59 Sheets

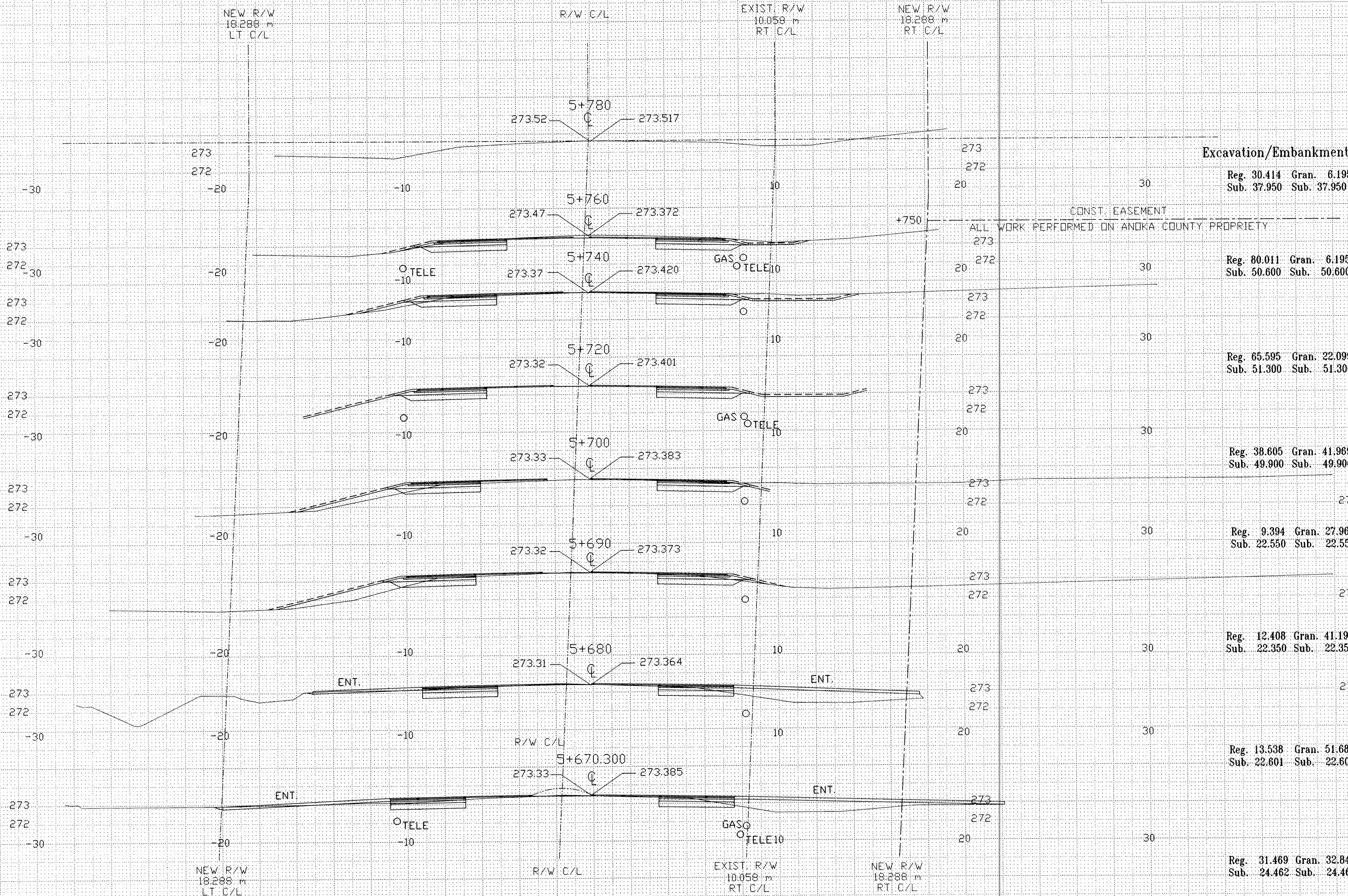

NO	DATE	BY	CKD	APPR	REVISION

NAME: X-SEC116.dwg 6398 21956

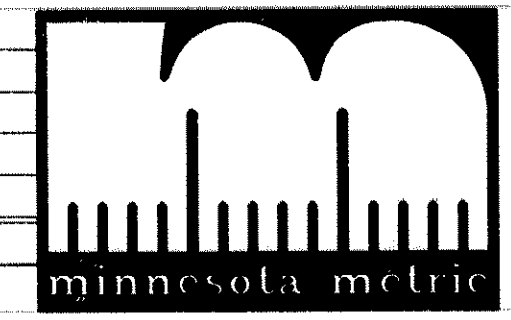

I HEREBY CERTIFY THAT THIS PLAN WAS PREPARED BY ME OR UNDER MY DIRECT SUPERVISION AND THAT I AM A DULY REGISTERED PROFESSIONAL ENGINEER UNDER THE LAWS OF THE STATE OF MINNESOTA.

DATE _____ REG. NO. _____

DRAWN BY: MN DATE 04/27/98
 DESIGN BY: DWF DATE 04/27/98
 CHECKED BY: DWF DATE 04/27/98

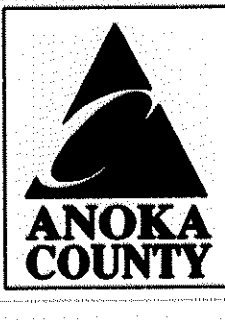

ANOKA COUNTY HIGHWAY DEPT.

STATE PROJECT NO. 02-678-12/02-716-02
 STATE AID PROJECT NO. _____
 STATE AID PROJECT NO. _____
 COUNTY PROJECT NO. _____

CROSS-SECTION
 CSAH 116
 STA 5+670.300 TO 5+780.000
 Sheet 42 of 59 Sheets

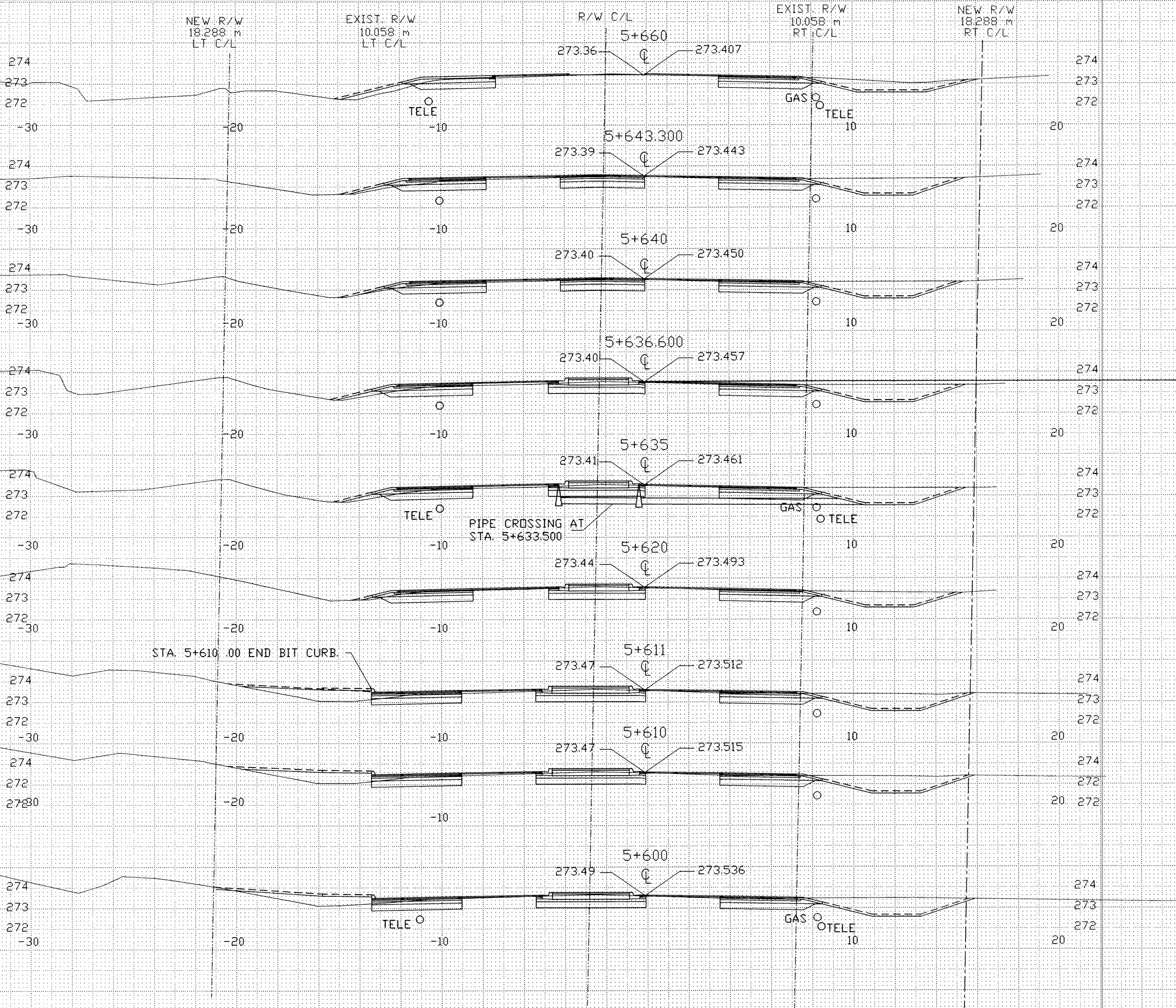

Excavation/Embankment
 Reg. 108,541 Gran. 13,951
 Sub. 41,700 Sub. 41,700

Reg. 22,390 Gran. 1,548
 Sub. 12,540 Sub. 12,540

Reg. 23,708 Gran. 1,859
 Sub. 13,175 Sub. 13,175

Reg. 11,399 Gran. 1,085
 Sub. 6,296 Sub. 6,296

Reg. 105,353 Gran. 6,673
 Sub. 59,400 Sub. 59,400

Reg. 63,198 Gran. 15,413
 Sub. 36,810 Sub. 36,810

Reg. 7,207 Gran. 3,163
 Sub. 4,205 Sub. 4,205

Reg. 76,824 Gran. 28,823
 Sub. 42,700 Sub. 42,700

Reg. 149,575 Gran. 44,864
 Sub. 86,600 Sub. 86,600

NO	DATE	BY	CKD	APPR	REVISION
NAME: X-SEC116.dwg	6398	21956			

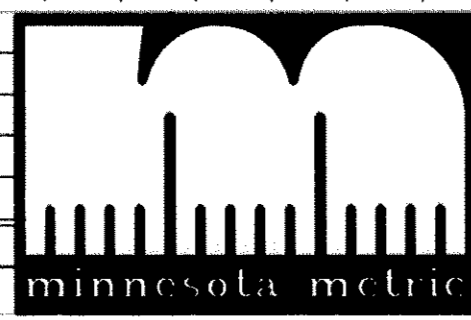

I HEREBY CERTIFY THAT THIS PLAN WAS PREPARED BY ME OR UNDER MY DIRECT SUPERVISION AND THAT I AM A DULY REGISTERED PROFESSIONAL ENGINEER UNDER THE LAWS OF THE STATE OF MINNESOTA.

DATE _____ REG. NO. _____

DRAWN BY: MN DATE 04/27/98
 DESIGN BY: DWF DATE 04/27/98
 CHECKED BY: DWF DATE 04/27/98

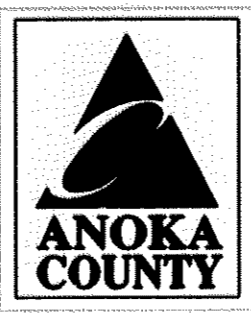

**ANOKA COUNTY
 HIGHWAY DEPT.**

STATE PROJECT NO. 02-678-12/02-716-02
 STATE AID PROJECT NO. _____
 STATE AID PROJECT NO. _____
 COUNTY PROJECT NO. _____

**CROSS-SECTION
 CSAH 116
 STA 5+600.000 TO 5+660.000**

Sheet 41 of 59 Sheets

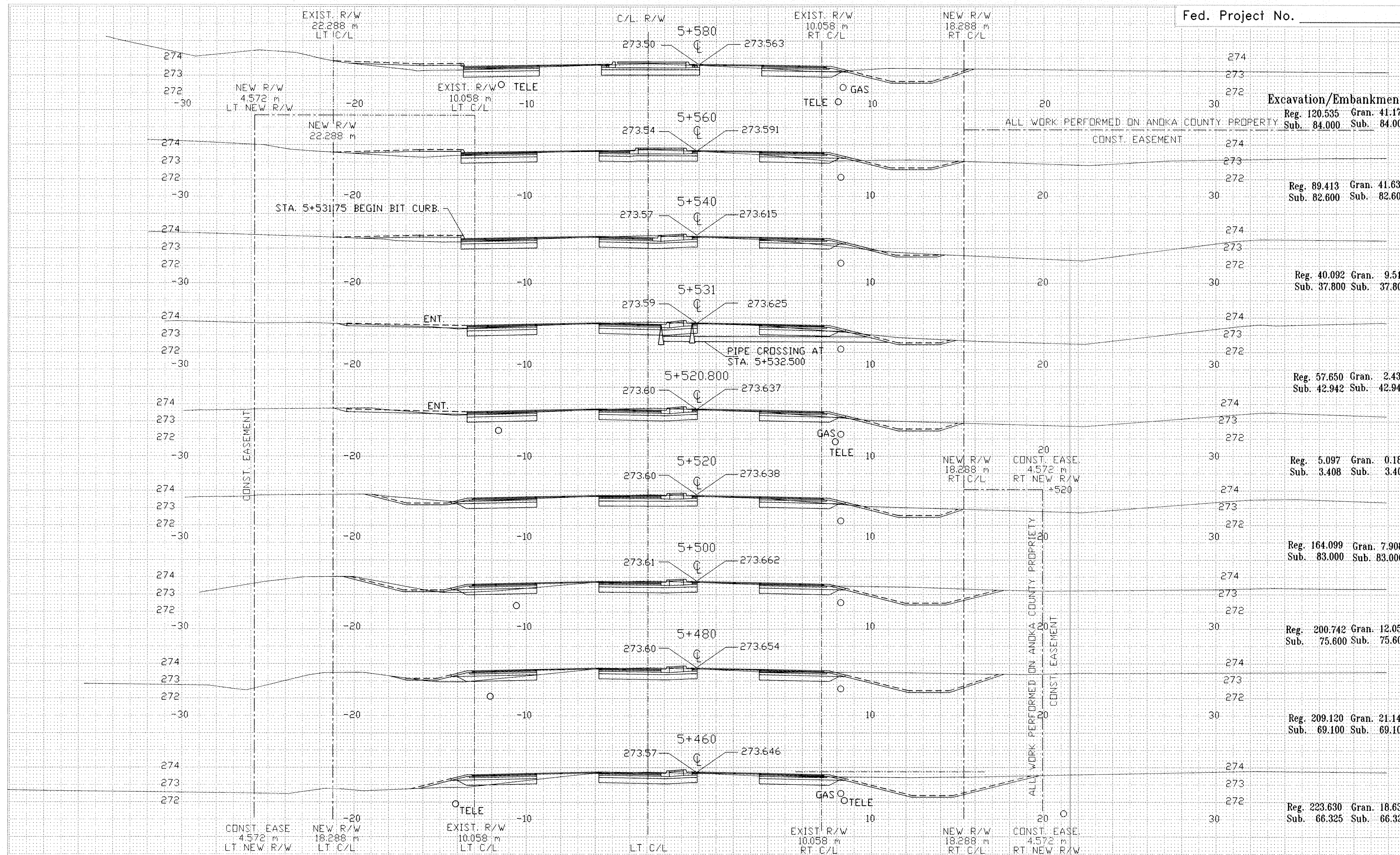

Excavation/Embankment
 Reg. 120.535 Gran. 41.175
 Sub. 84.000 Sub. 84.000

Reg. 89.413 Gran. 41.634
 Sub. 82.600 Sub. 82.600

Reg. 40.092 Gran. 9.513
 Sub. 37.800 Sub. 37.800

Reg. 57.650 Gran. 2.434
 Sub. 42.942 Sub. 42.942

Reg. 5.097 Gran. 0.187
 Sub. 3.408 Sub. 3.408

Reg. 164.099 Gran. 7.908
 Sub. 83.000 Sub. 83.000

Reg. 200.742 Gran. 12.056
 Sub. 75.600 Sub. 75.600

Reg. 209.120 Gran. 21.140
 Sub. 69.100 Sub. 69.100

Reg. 223.630 Gran. 18.634
 Sub. 66.325 Sub. 66.325

NO	DATE	BY	CKD	APPR	REVISION



I HEREBY CERTIFY THAT THIS PLAN WAS PREPARED BY ME OR UNDER MY DIRECT SUPERVISION AND THAT I AM A DULY REGISTERED PROFESSIONAL ENGINEER UNDER THE LAWS OF THE STATE OF MINNESOTA.

DATE _____ REG. NO. _____

DRAWN BY: MN DATE 04/27/98
 DESIGN BY: DWF DATE 04/27/98
 CHECKED BY: DWF DATE 04/27/98

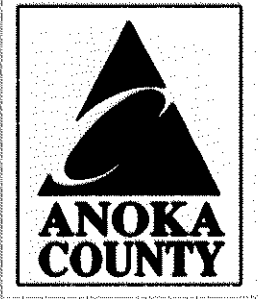

ANOKA COUNTY
HIGHWAY DEPT.

STATE PROJECT NO. 02-678-12/02-716-02
 STATE AID PROJECT NO. _____
 STATE AID PROJECT NO. _____
 COUNTY PROJECT NO. _____

CROSS-SECTION
 CSAH 116
 STA 5+460.000 TO 5+580.000
 Sheet 40 of 59 Sheets

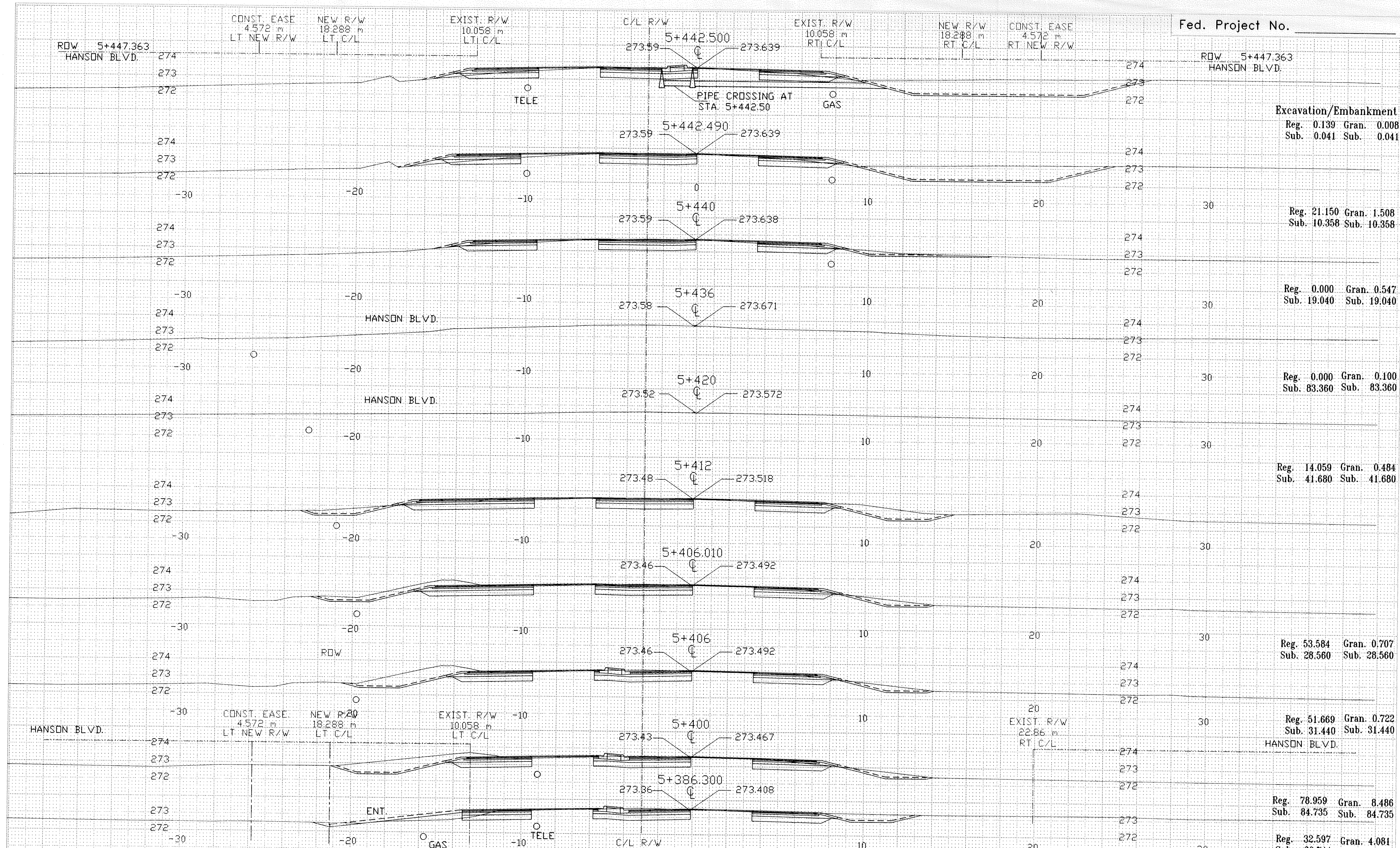

NO	DATE	BY	CKD	APPR	REVISION
NAME	X-SEC116.dwg	6398	21956		

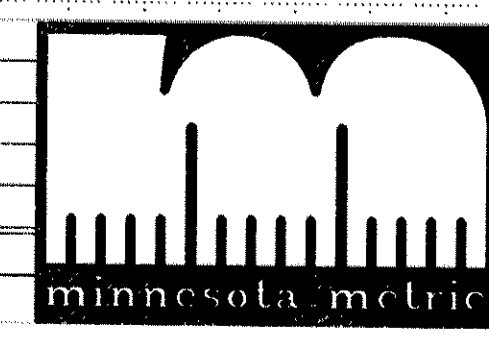

I HEREBY CERTIFY THAT THIS PLAN WAS PREPARED BY ME OR UNDER MY DIRECT SUPERVISION AND THAT I AM A DULY REGISTERED PROFESSIONAL ENGINEER UNDER THE LAWS OF THE STATE OF MINNESOTA.

DATE _____ REG. NO. _____

DRAWN BY: MN DATE 04/27/98
DESIGN BY: DWF DATE 04/27/98
CHECKED BY: DWE DATE 04/27/98

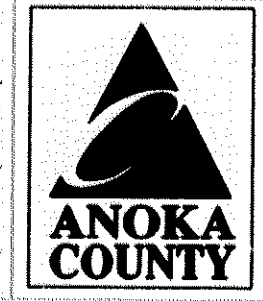

**ANOKA COUNTY
HIGHWAY DEPT.**

STATE PROJECT NO. 02-678-12/02-716-02
STATE AID PROJECT NO. _____
STATE AID PROJECT NO. _____
COUNTY PROJECT NO. _____

CROSS-SECTION
CSAH 116
STA 5+386.300 TO 5+442.500
Sheet 39 of 59 Sheets

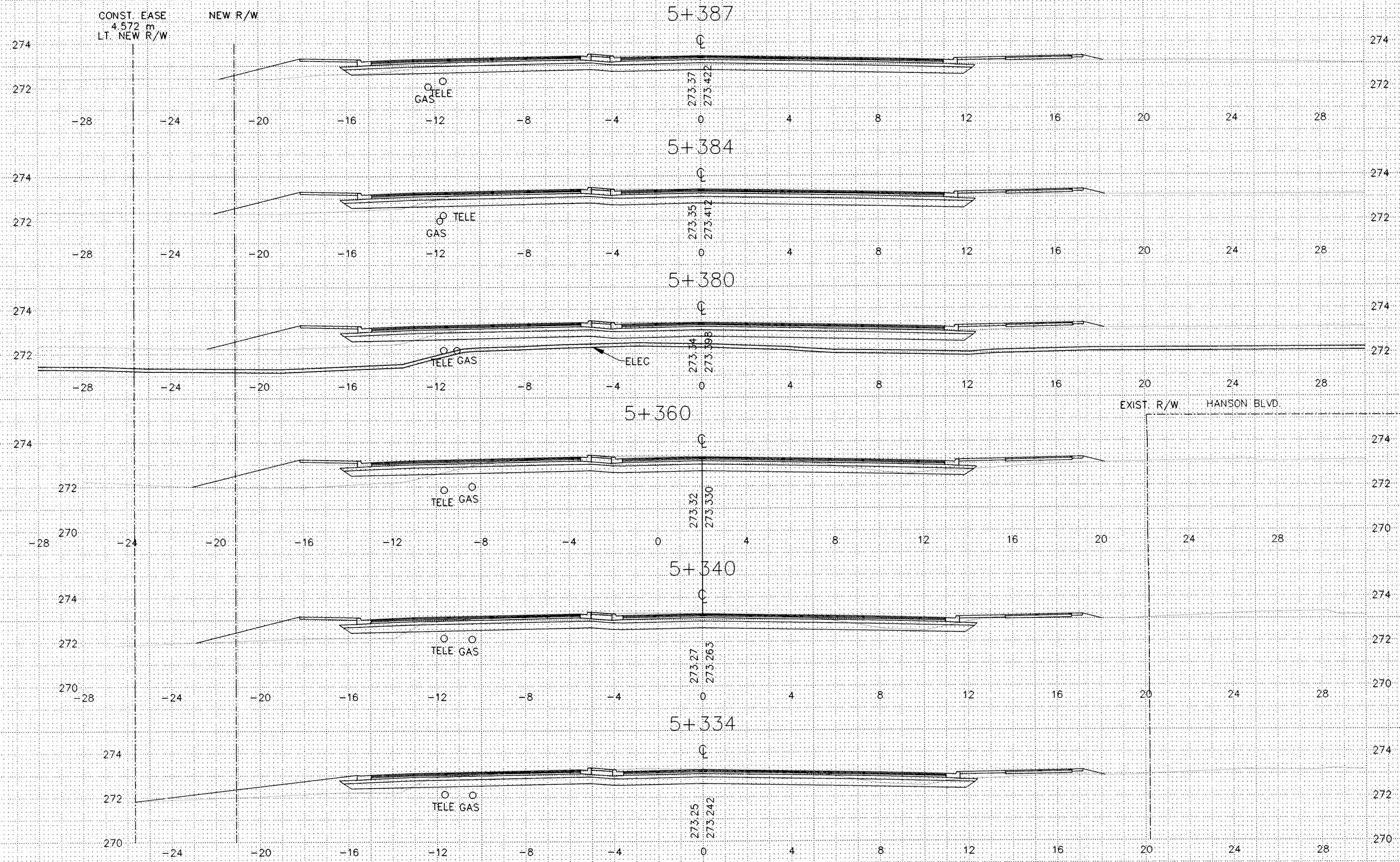

1	6/15/99	KLO	LAR		Cross-sections were revised to reflect change of west leg of CSAH 116 from a rural to an urban section.
NO	DATE	BY	CKD	APPR	REVISION
NAME: S:\SDSKPROJ\000000\000000\026000.DWG					

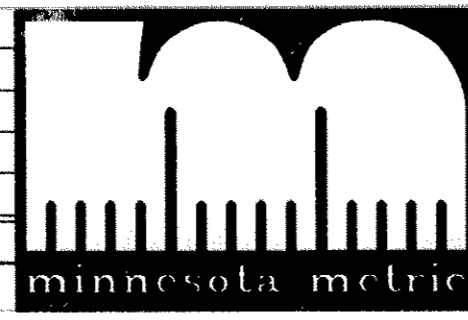

I HEREBY CERTIFY THAT THIS PLAN WAS PREPARED BY ME OR UNDER MY DIRECT SUPERVISION AND THAT I AM A DULY REGISTERED PROFESSIONAL ENGINEER UNDER THE LAWS OF THE STATE OF MINNESOTA.

DATE _____ REG. NO. _____

DRAWN BY MN DATE 00/00/98
 DESIGN BY DWF DATE 00/00/98
 CHECKED BY DWF DATE 00/00/98

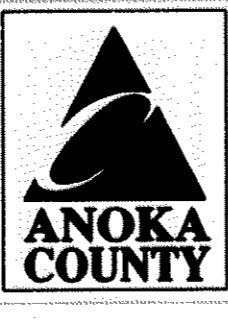

**ANOKA COUNTY
HIGHWAY DEPT.**

STATE PROJECT NO. 02-678-12
 STATE PROJECT NO. 02-716-02
 STATE AID PROJECT NO. _____
 COUNTY PROJECT NO. _____

**CROSS- SECTION
CSAH 116
STA 5+334.000 TO 5+387.000**

Sheet 37 of 59 Sheets

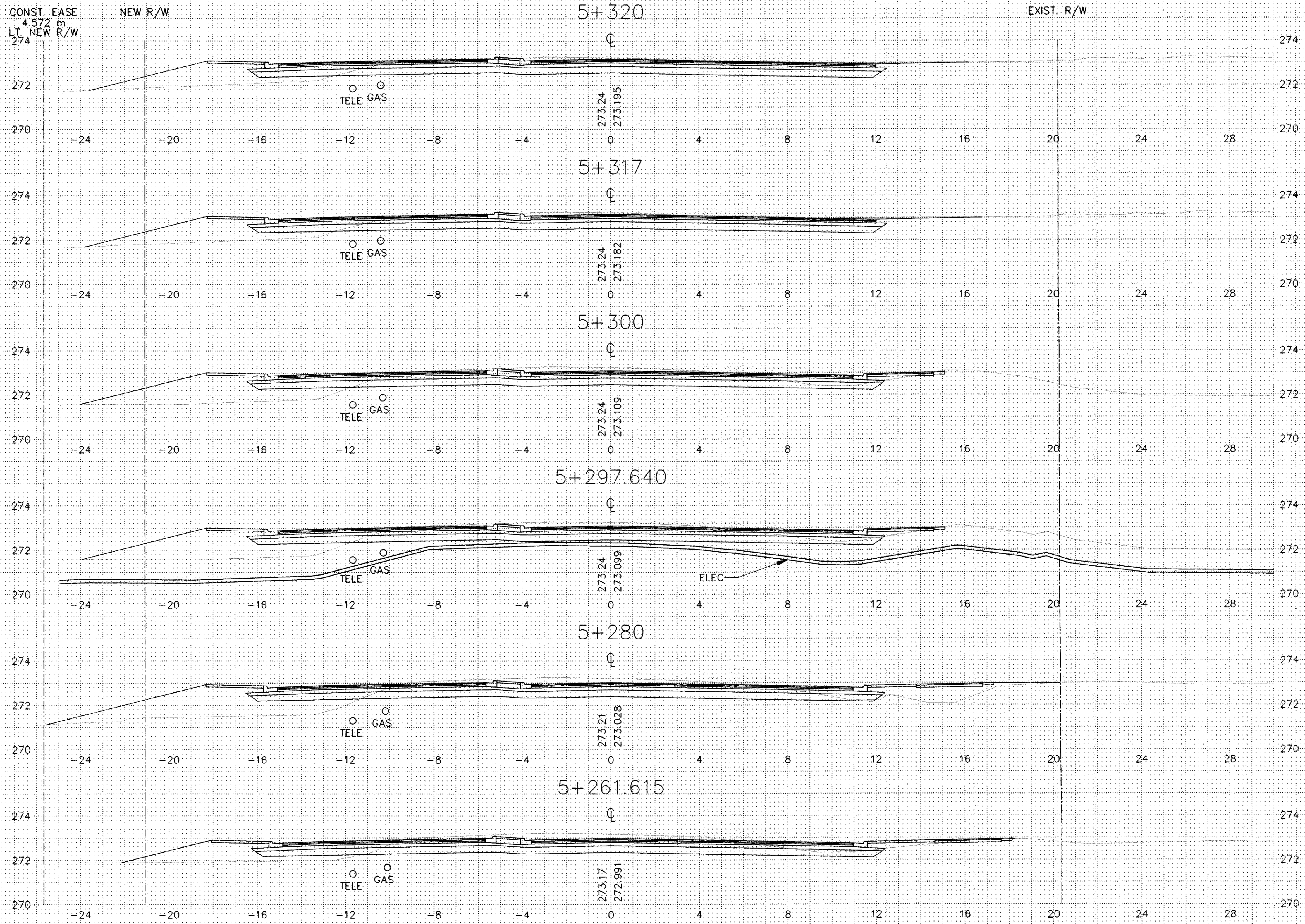

1	6/15/99	KLO	LAR		Cross-sections were revised to reflect change of west leg of CSAH 116 from a rural to an urban section.
NO	DATE	BY	CKD	APPR	REVISION
NAME: S:\SDSKPROJ\000000\000000\026000.DWG					



I HEREBY CERTIFY THAT THIS PLAN WAS PREPARED BY ME OR UNDER MY DIRECT SUPERVISION AND THAT I AM A DULY REGISTERED PROFESSIONAL ENGINEER UNDER THE LAWS OF THE STATE OF MINNESOTA.

DATE _____ REG. NO. _____

DRAWN BY: _____ MN. DATE 00/00/98
 DESIGN BY: _____ DWF DATE 00/00/98
 CHECKED BY: _____ DWF DATE 00/00/98

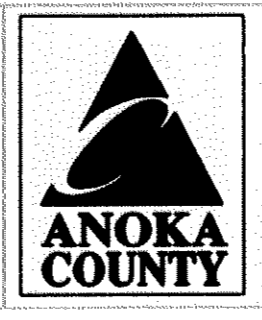

**ANOKA COUNTY
HIGHWAY DEPT.**

STATE PROJECT NO. 02-678-12
 STATE PROJECT NO. 02-716-02
 STATE AID PROJECT NO. _____
 COUNTY PROJECT NO. _____

**CROSS-SECTION
CSAH 116
STA 5+261.615 TO 5+320.000**

Sheet 36 of 59 Sheets

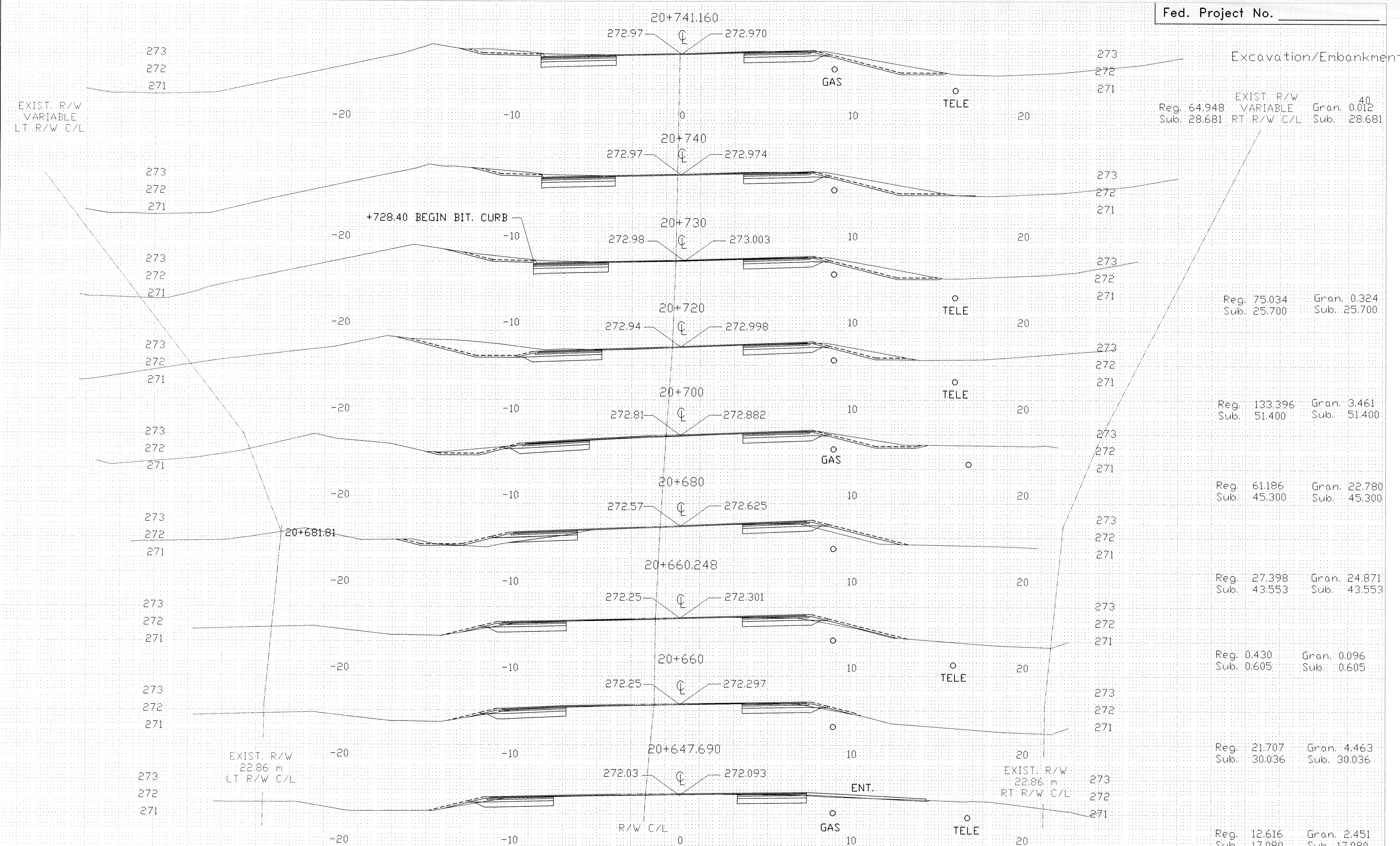

Reg. 64,948 Sub. 28,681

Reg. 75,034 Sub. 25,700

Reg. 133,396 Sub. 51,400

Reg. 61,186 Sub. 45,300

Reg. 27,398 Sub. 43,553

Reg. 0,430 Sub. 0,605

Reg. 21,707 Sub. 30,036

Reg. 12,616 Sub. 17,080

NO	DATE	BY	CKD	APPR	REVISION

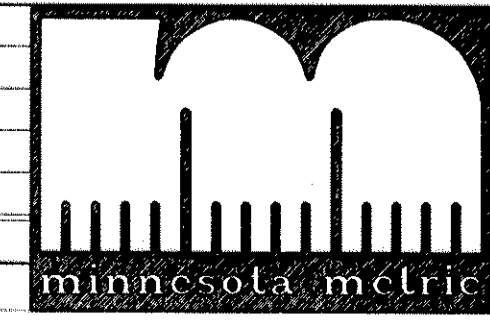

I HEREBY CERTIFY THAT THIS PLAN WAS PREPARED BY ME OR UNDER MY DIRECT SUPERVISION AND THAT I AM A DULY REGISTERED PROFESSIONAL ENGINEER UNDER THE LAWS OF THE STATE OF MINNESOTA.

DATE _____ REG. NO. _____

DRAWN BY: MN. DATE 04/27/98
 DESIGN BY: DWF DATE 04/27/98
 CHECKED BY: DWF DATE 04/27/98

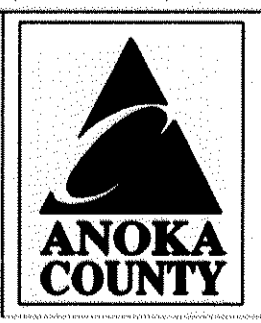

**ANOKA COUNTY
HIGHWAY DEPT.**

STATE PROJECT NO. **02-678-12/02-716-02**
 STATE AID PROJECT NO. _____
 STATE AID PROJECT NO. _____
 COUNTY PROJECT NO. _____

CROSS-SECTION
 CSAH 78
 STA 20+647.690 TO 20+741.160
 Sheet **35** of **59** Sheets

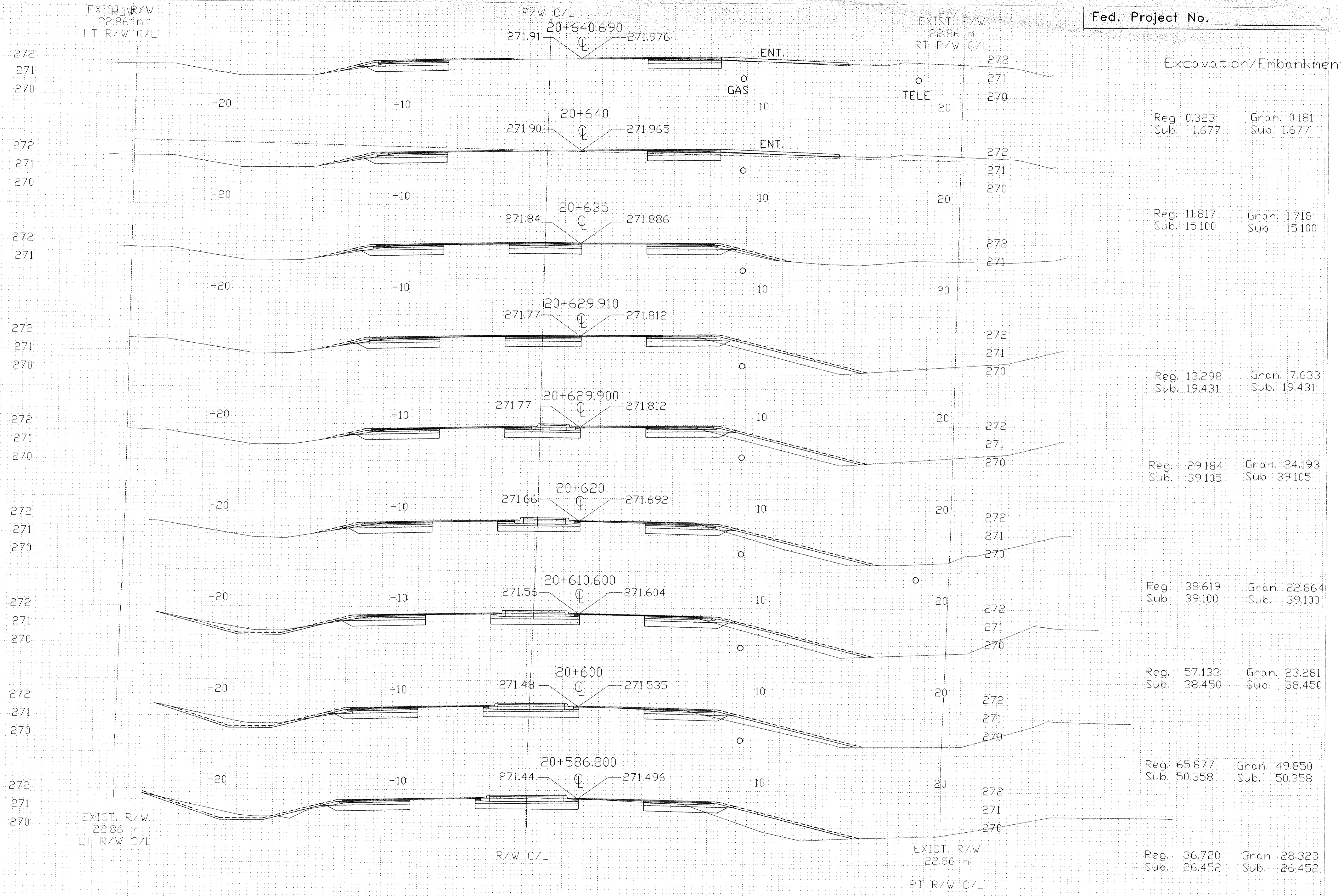

NO	DATE	BY	CKD	APPR	REVISION
NAME: X-SEC78.dwg	5198	43932			

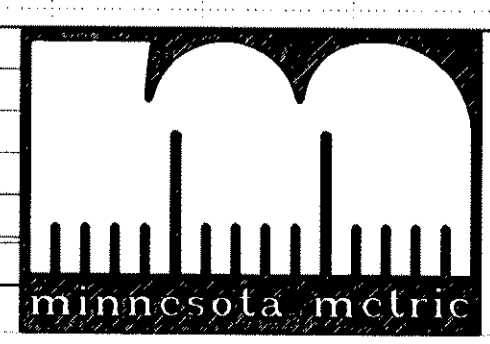

I HEREBY CERTIFY THAT THIS PLAN WAS PREPARED BY ME OR UNDER MY DIRECT SUPERVISION AND THAT I AM A DULY REGISTERED PROFESSIONAL ENGINEER UNDER THE LAWS OF THE STATE OF MINNESOTA.

DATE _____ REG. NO. _____

DRAWN BY _____ MN DATE 04/27/98
 DESIGN BY _____ DWF DATE 04/27/98
 CHECKED BY _____ DWF DATE 04/27/98



**ANOKA COUNTY
HIGHWAY DEPT.**

STATE PROJECT NO. 02-678-12/02-716-02
 STATE AID PROJECT NO. _____
 STATE AID PROJECT NO. _____
 COUNTY PROJECT NO. _____

CROSS-SECTION
 CSAH 78
 STA 20+580 TO 20+640.690
 Sheet 34 of 59 Sheets

EXIST. R/W
22.86 m
LT R/W C/L

C/L R/W

EXIST. R/W
22.86 m
RT R/W C/L

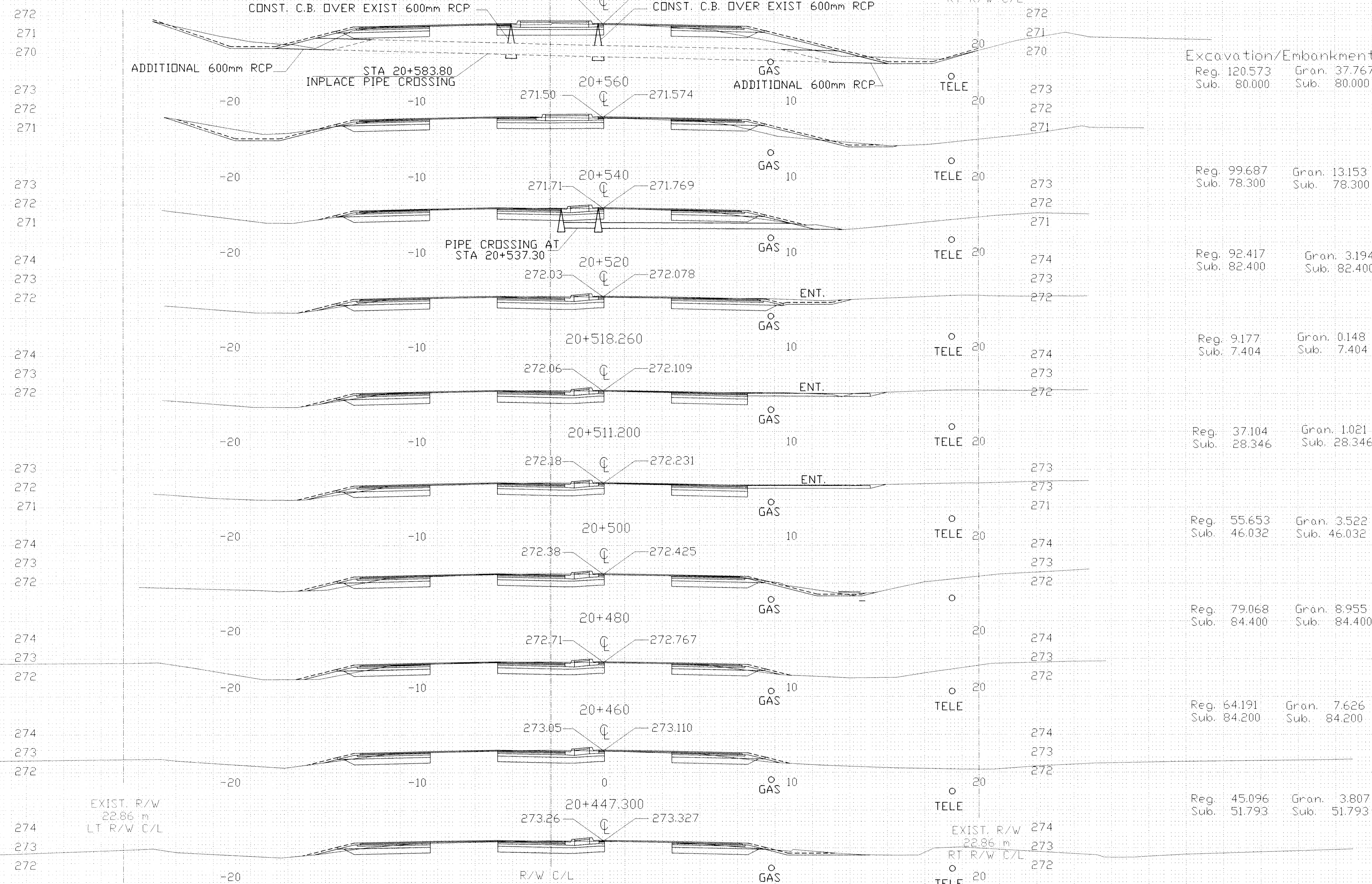

EXIST. R/W
22.86 m
LT R/W C/L

R/W C/L

EXIST. R/W
22.86 m
RT R/W C/L

NO	DATE	BY	CKD	APPR	REVISION

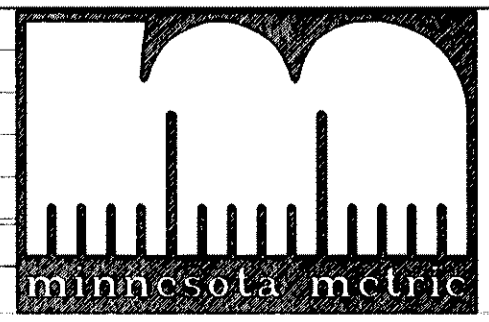

I HEREBY CERTIFY THAT THIS PLAN WAS PREPARED BY ME OR UNDER MY DIRECT SUPERVISION AND THAT I AM A DULY REGISTERED PROFESSIONAL ENGINEER UNDER THE LAWS OF THE STATE OF MINNESOTA.

DATE _____ REG. NO. _____

DRAWN BY MN DATE 04/27/98
 DESIGN BY DWF DATE 04/27/98
 CHECKED BY DWF DATE 04/27/98

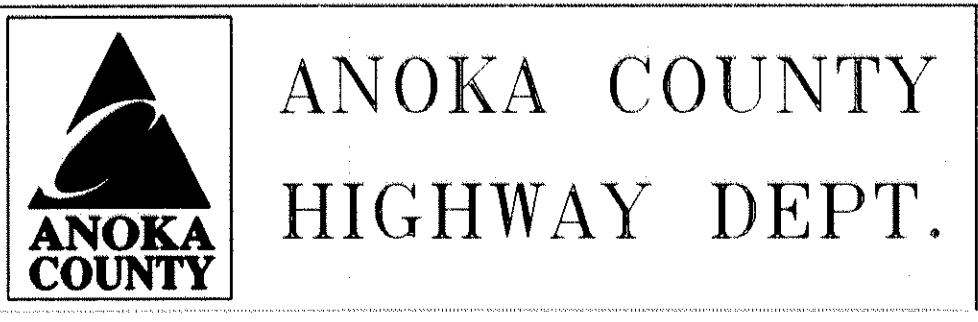

STATE PROJECT NO. 02-678-12/02-716-02
 STATE AID PROJECT NO. _____
 STATE AID PROJECT NO. _____
 COUNTY PROJECT NO. _____

CROSS-SECTION
 CSAH 78
 STA 20+447.300 TO 20+580
 Sheet 33 of 59 Sheets

Fed. Project No. _____

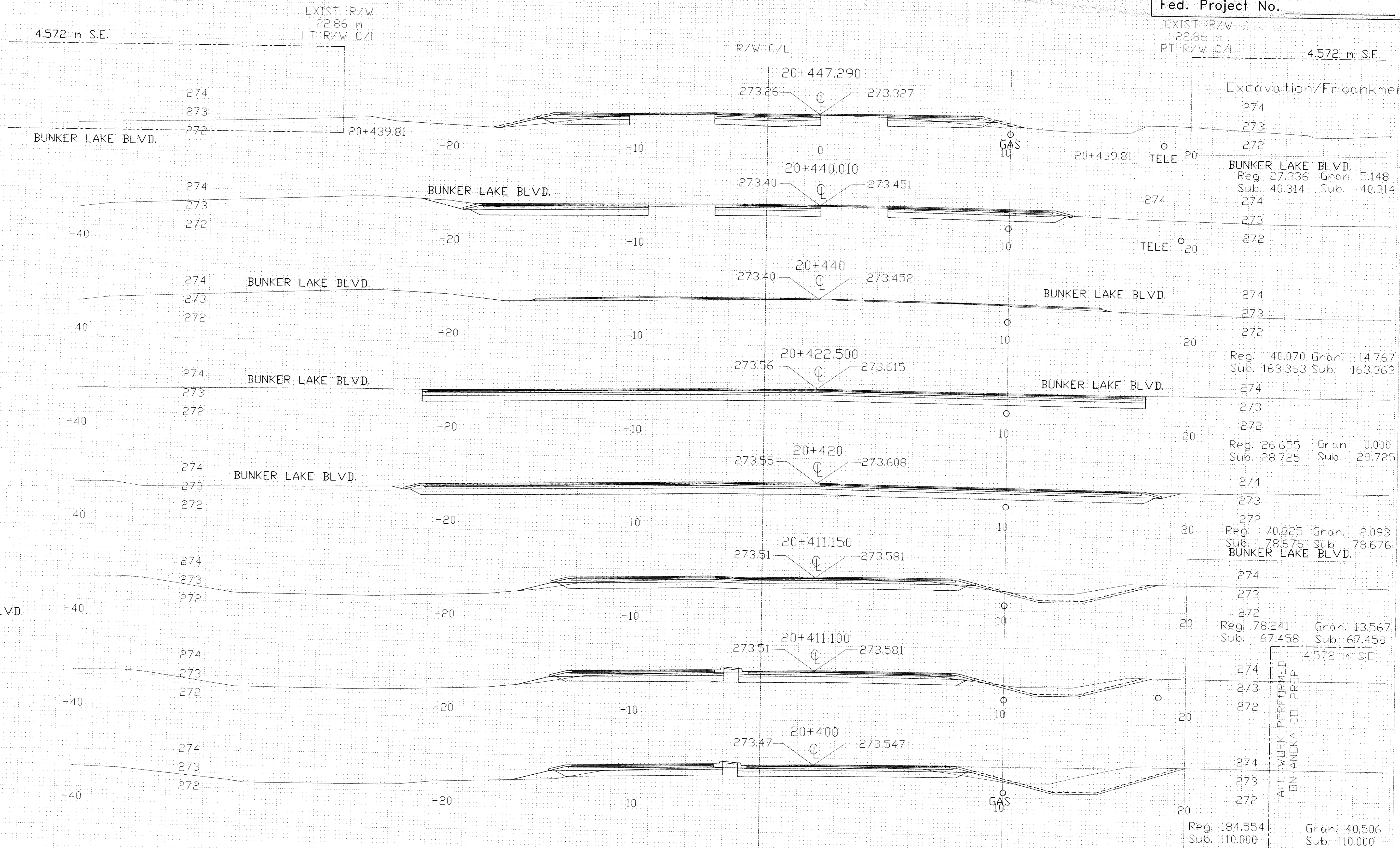

4.572 m S.E.

EXIST. R/W
22.86 m
LT R/W C/L

R/W C/L

EXIST. R/W
22.86 m
RT R/W C/L

4.572 m S.E.

Excavation/Embankment

BUNKER LAKE BLVD.
Reg. 27.336 Gran. 5.148
Sub. 40.314 Sub. 40.314

Reg. 40.070 Gran. 14.767
Sub. 163.363 Sub. 163.363

Reg. 26.655 Gran. 0.000
Sub. 28.725 Sub. 28.725

Reg. 70.825 Gran. 2.093
Sub. 78.676 Sub. 78.676
BUNKER LAKE BLVD.

Reg. 78.241 Gran. 13.567
Sub. 67.458 Sub. 67.458

4.572 m S.E.

Reg. 184.554 Gran. 40.506
Sub. 110.000 Sub. 110.000

EXIST. R/W
22.86 m
RT R/W C/L

CONST. EASE
4.572 m
RT EX RW

EXIST. R/W
45.718 m
LT R/W C/L

NO	DATE	BY	CKD	APPR	REVISION
1	X-SEC78.dwg	5198		43932	

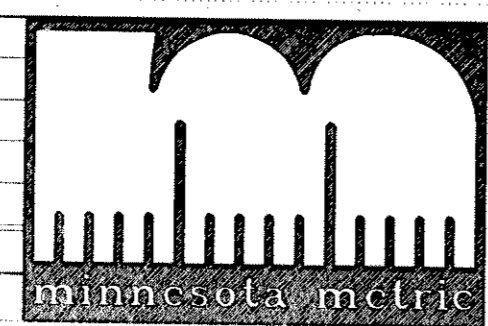

I HEREBY CERTIFY THAT THIS PLAN WAS PREPARED BY ME OR UNDER MY DIRECT SUPERVISION AND THAT I AM A DULY REGISTERED PROFESSIONAL ENGINEER UNDER THE LAWS OF THE STATE OF MINNESOTA.

DATE _____ REG. NO. _____

DRAWN BY: MN DATE 04/27/98
 DESIGN BY: DWF DATE 04/27/98
 CHECKED BY: DWF DATE 04/27/98



ANOKA COUNTY
HIGHWAY DEPT.

STATE PROJECT NO. 02-678-12/02-716-02
 STATE AID PROJECT NO. _____
 STATE AID PROJECT NO. _____
 COUNTY PROJECT NO. _____

CROSS-SECTION
 CSAH 78
 STA 20+380.000 TO 20+447.290
 Sheet 32 of 59 Sheets

ALL WORK PERFORMED
ON ANOKA CO. PROP.

EXIST. R/W
45.718 m
LT R/W C/L

Fed. Project No. _____

R/W C/L

EXIST. R/W 22.86 m
RT R/W C/L
CONST. EASE 4.572 m
RT NEW R/W
Excavation/Embankment

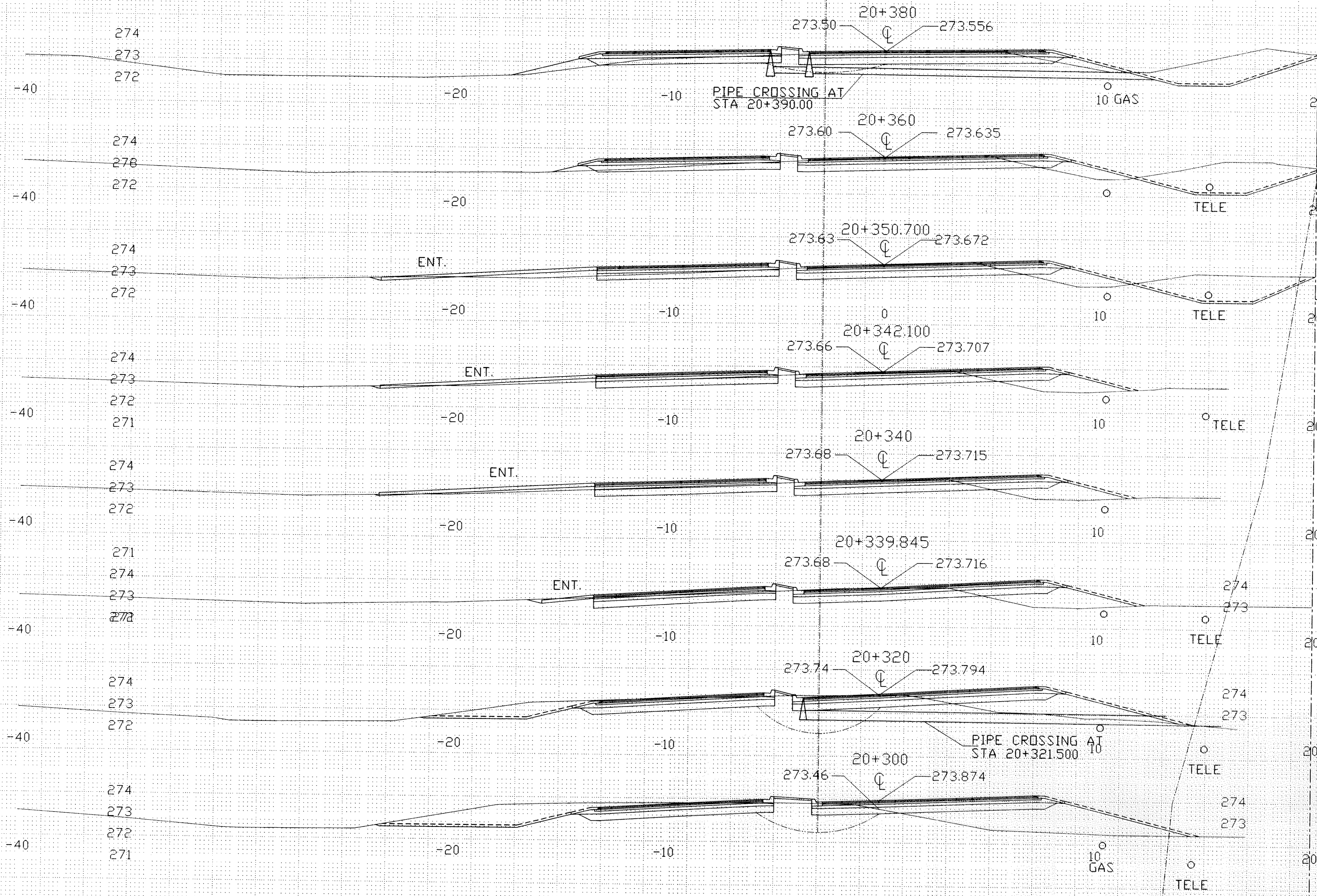

ALL WORK PERFORMED ON ANOKA CO. PROP.

274	Reg. 216.333	Gran. 48.933
273	Sub. 99.200	Sub. 99.200
272		
274	Reg. 98.748	Gran. 30.142
273	Sub. 45.198	Sub. 45.198
272		
274		
273		
272		
274	Reg. 52.585	Gran. 35.688
273	Sub. 44.500	Sub. 44.500
272		
274		
273		
272		
271	Reg. 6.491	Gran. 8.649
274	Sub. 10.280	Sub. 10.280
273		
272		
274	Reg. 0.478	Gran. 0.709
273	Sub. 0.810	Sub. 0.810
272		
274		
273		
272		
274	Reg. 99.075	Gran. 121.256
273	Sub. 96.621	Sub. 96.621
272		
274		
273		
272		
274	Reg. 160.227	Gran. 198.56
273	Sub. 84.000	Sub. 84.000
272		
274		
273		
272		
271	Reg. 29.497	Gran. 46.32
274	Sub. 12.281	Sub. 12.281

20+339.191

EXIST. R/W
VARIABLE
LT R/W C/L

R/W C/L

EXIST. R/W 22.86 m
RT R/W C/L
NEW R/W 16.41 m
RT LNB C/L

NO	DATE	BY	CKD	APPR	REVISION
NAME:	X-SEC78.dwg	5198	43932		



I HEREBY CERTIFY THAT THIS PLAN WAS PREPARED BY ME OR UNDER MY DIRECT SUPERVISION AND THAT I AM A DULY REGISTERED PROFESSIONAL ENGINEER UNDER THE LAWS OF THE STATE OF MINNESOTA.

DATE _____ REG. NO. _____

DRAWN BY...MN... DATE 04/27/98
DESIGN BY...DWF... DATE 04/27/98
CHECKED BY...DWF... DATE 04/27/98



ANOKA COUNTY
HIGHWAY DEPT.

STATE PROJECT NO. 02-678-12/02-716-02
STATE AID PROJECT NO. _____
STATE AID PROJECT NO. _____
COUNTY PROJECT NO. _____

CROSS-SECTION
CSAH 78
STA 20+300.000 TO 20+380.000
Sheet 31 of 59 Sheets

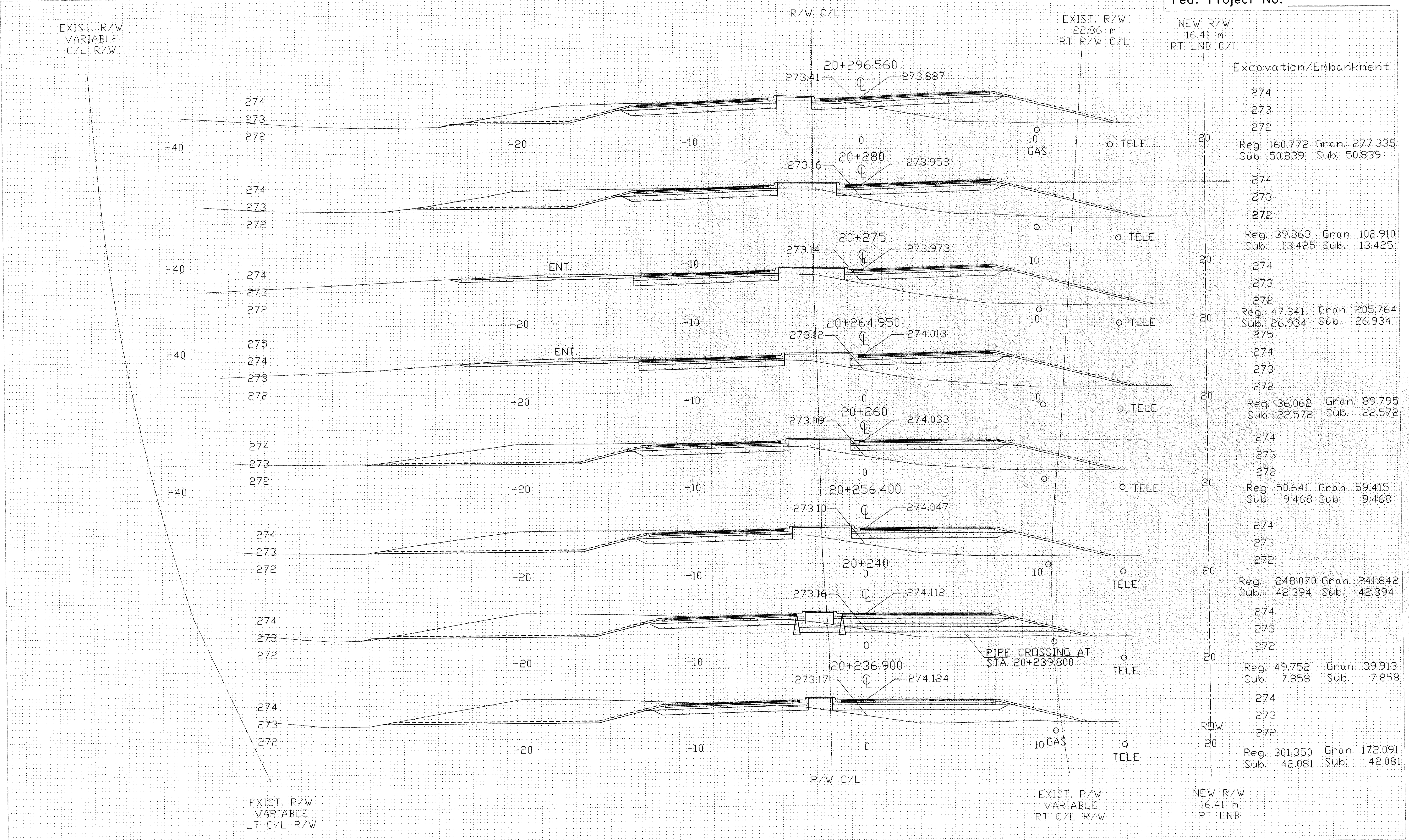

NO	DATE	BY	CKD	APPR	REVISION

NAME: X-SEC78.dwg 5198 43932

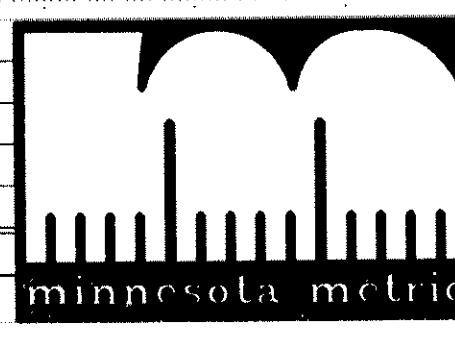

I HEREBY CERTIFY THAT THIS PLAN WAS PREPARED BY ME OR UNDER MY DIRECT SUPERVISION AND THAT I AM A DULY REGISTERED PROFESSIONAL ENGINEER UNDER THE LAWS OF THE STATE OF MINNESOTA.

DATE _____ REG. NO. _____

DRAWN BY MN DATE 04/27/98
 DESIGN BY DWF DATE 04/27/98
 CHECKED BY DWF DATE 04/27/98

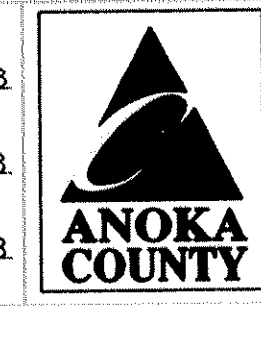

**ANOKA COUNTY
HIGHWAY DEPT.**

STATE PROJECT NO. 02-678-12/02-716-02
 STATE AID PROJECT NO. _____
 STATE AID PROJECT NO. _____
 COUNTY PROJECT NO. _____

CROSS-SECTION
 CSAH 78
 STA 20+236.900 + 20+296.560
 Sheet 30 of 59 Sheets

EXIST. R/W
VARIABLE
LT R/W C/L

R/W C/L

EXIST. R/W
22.86 m
RT R/W C/L

NEW R/W
16.41 m
RT LNB

Excavation/Embankment

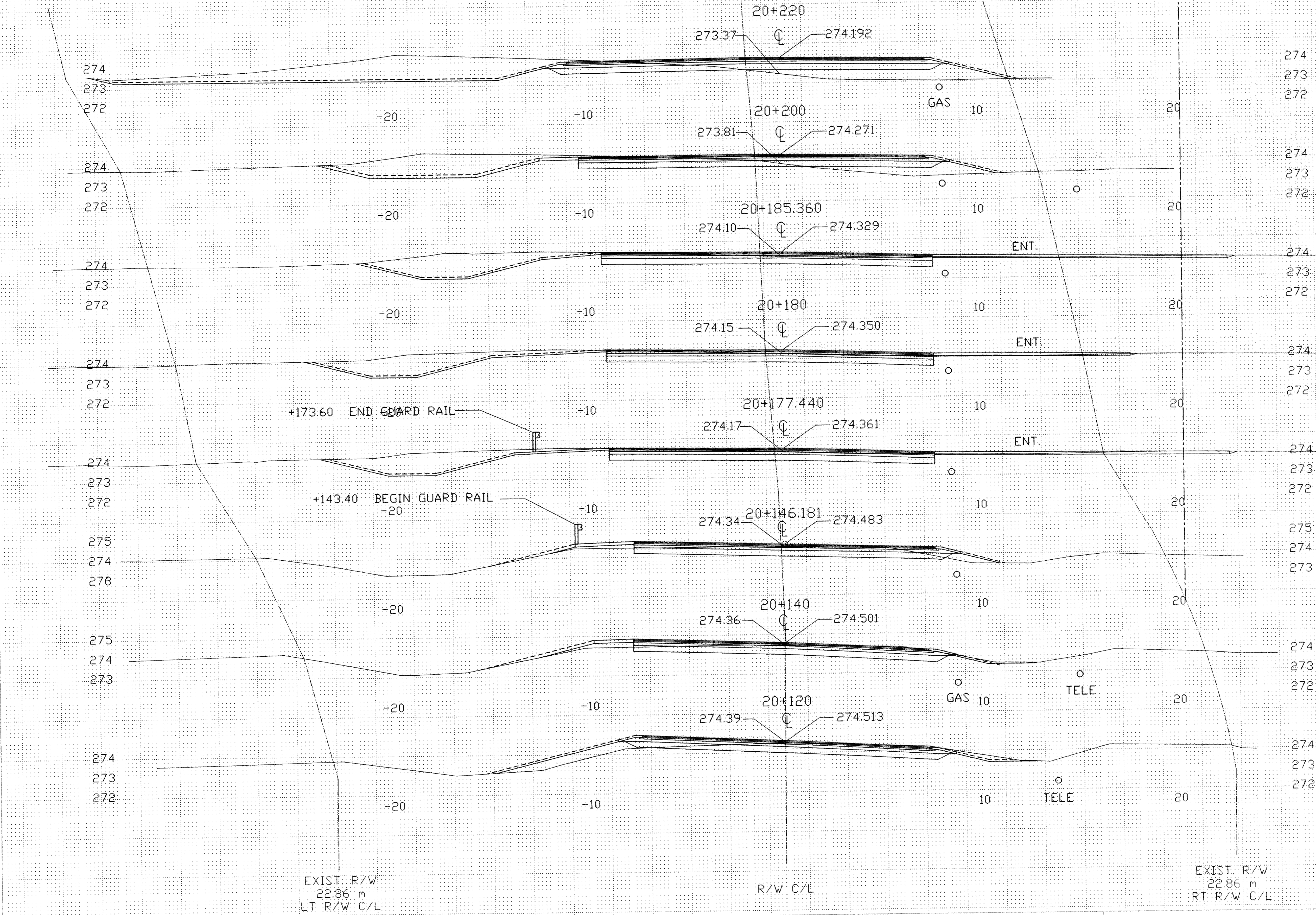

Reg. 309.740 Gran. 120.584
Sub. 56.300 Sub. 56.300

Reg. 176.162 Gran. 22.028
Sub. 59.348 Sub. 59.438

Reg. 63.379 Gran. 0.000
Sub. 26.532 Sub. 26.352

Reg. 29.849 Gran. 0.000
Sub. 12.736 Sub. 12.736

Reg. 218.520 Gran. 17.052
Sub. 149.266 Sub. 149.266

Reg. 5.954 Gran. 5.726
Sub. 26.327 Sub. 26.327

Reg. 69.649 Gran. 33.705
Sub. 78.200 Sub. 78.200

Reg. 80.527 Gran. 72.023
Sub. 77.400 Sub. 77.400

EXIST. R/W
22.86 m
LT R/W C/L

R/W C/L

EXIST. R/W
22.86 m
RT R/W C/L

NO	DATE	BY	CKD	APPR	REVISION

NAME: X-SEC78.dwg 5198 43932



I HEREBY CERTIFY THAT THIS PLAN WAS PREPARED BY ME OR UNDER MY DIRECT SUPERVISION AND THAT I AM A DULY REGISTERED PROFESSIONAL ENGINEER UNDER THE LAWS OF THE STATE OF MINNESOTA.

DRAWN BY: MN DATE 04/27/98
DESIGN BY: DWF DATE 04/27/98
CHECKED BY: DWF DATE 04/27/98



ANOKA COUNTY
HIGHWAY DEPT.

STATE PROJECT NO. 02-678-12/02-716-02
STATE AID PROJECT NO. _____
STATE AID PROJECT NO. _____
COUNTY PROJECT NO. _____

CROSS-SECTION
CSAH 78
STA 20+120 TO 20+220
Sheet 29 of 59 Sheets

EXIST. R/W
22.86 m
LT R/W C/L

R/W C/L

EXIST. R/W
22.86 m
RT R/W C/L

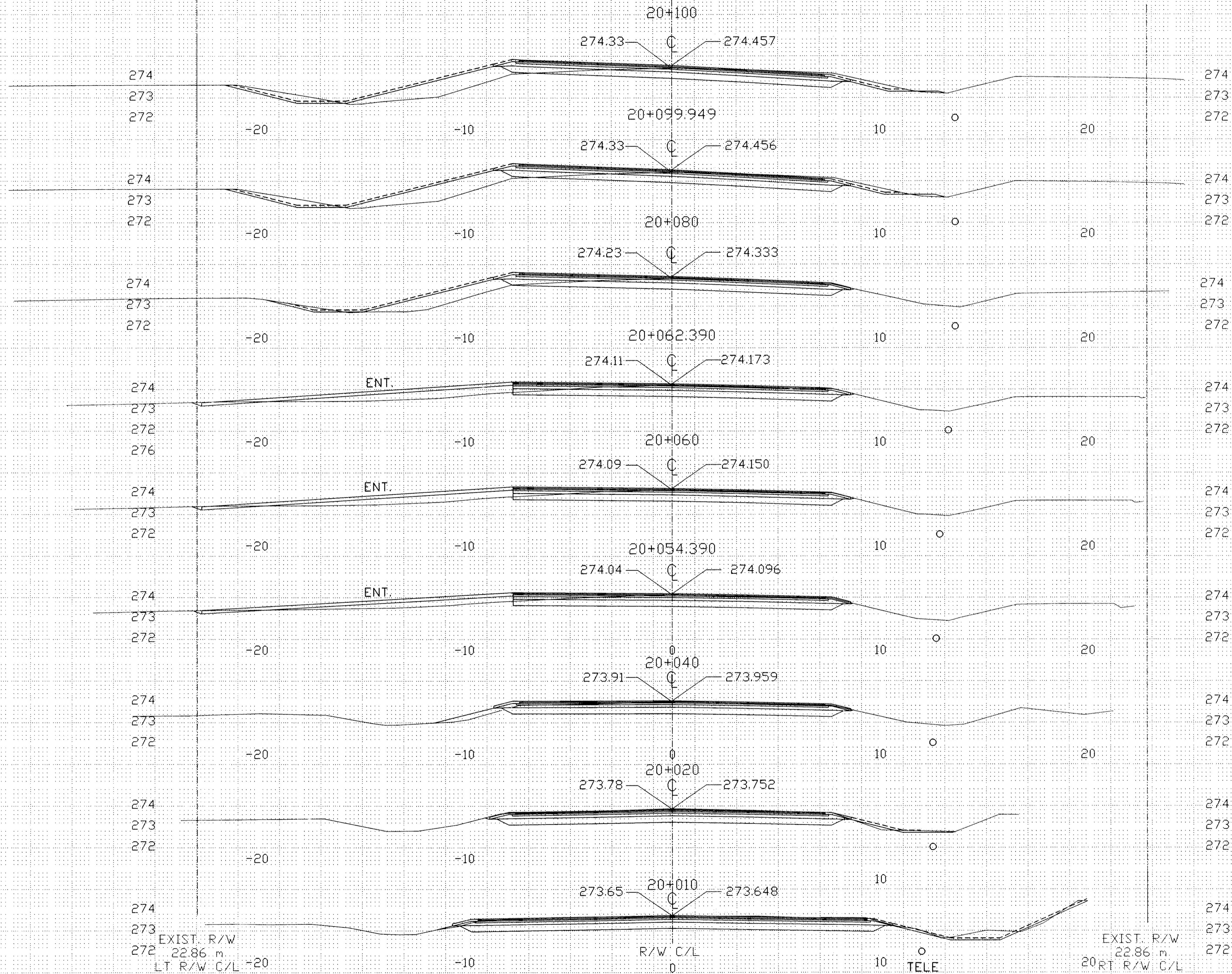

Excavation/Embankment
Reg. 0.205 Gran. 0.236
Sub. 0.233 Sub. 0.233

Reg. 107.778 Gran. 44.968
Sub. 80.059 Sub. 80.059

Reg. 81.653 Gran. 28.706
Sub. 75.635 Sub. 75.635

Reg. 7.435 Gran. 7.545
Sub. 10.695 Sub. 10.695

Reg. 17.528 Gran. 15.332
Sub. 25.582 Sub. 25.582

Reg. 47.453 Gran. 21.749
Sub. 67.489 Sub. 67.489

Reg. 101.499 Gran. 6.107
Sub. 105.300 Sub. 105.300

Reg. 71.960 Gran. 0.817
Sub. 57.700 Sub. 57.700

EXIST. R/W
22.86 m
LT R/W C/L

R/W C/L

EXIST. R/W
22.86 m
RT R/W C/L

NO	DATE	BY	CKD	APPR	REVISION

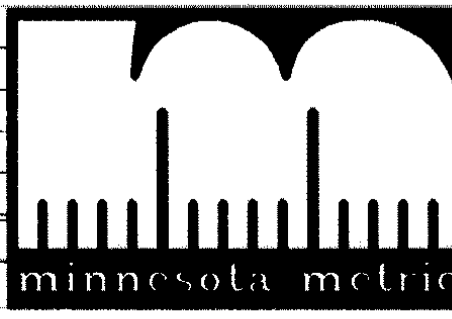

I HEREBY CERTIFY THAT THIS PLAN WAS PREPARED BY ME OR UNDER MY DIRECT SUPERVISION AND THAT I AM A DULY REGISTERED PROFESSIONAL ENGINEER UNDER THE LAWS OF THE STATE OF MINNESOTA.
DATE _____ REG. NO. _____

DRAWN BY: MN DATE 04/27/98
DESIGN BY: DWF DATE 04/27/98
CHECKED BY: DWF DATE 04/27/98



**ANOKA COUNTY
HIGHWAY DEPT.**

STATE PROJECT NO. 02-678-12/02-716-02
STATE AID PROJECT NO. _____
STATE AID PROJECT NO. _____
COUNTY PROJECT NO. _____

CROSS-SECTION
CSAH 78
STA 20+010 TO 20+100
Sheet 28 of 59 Sheets

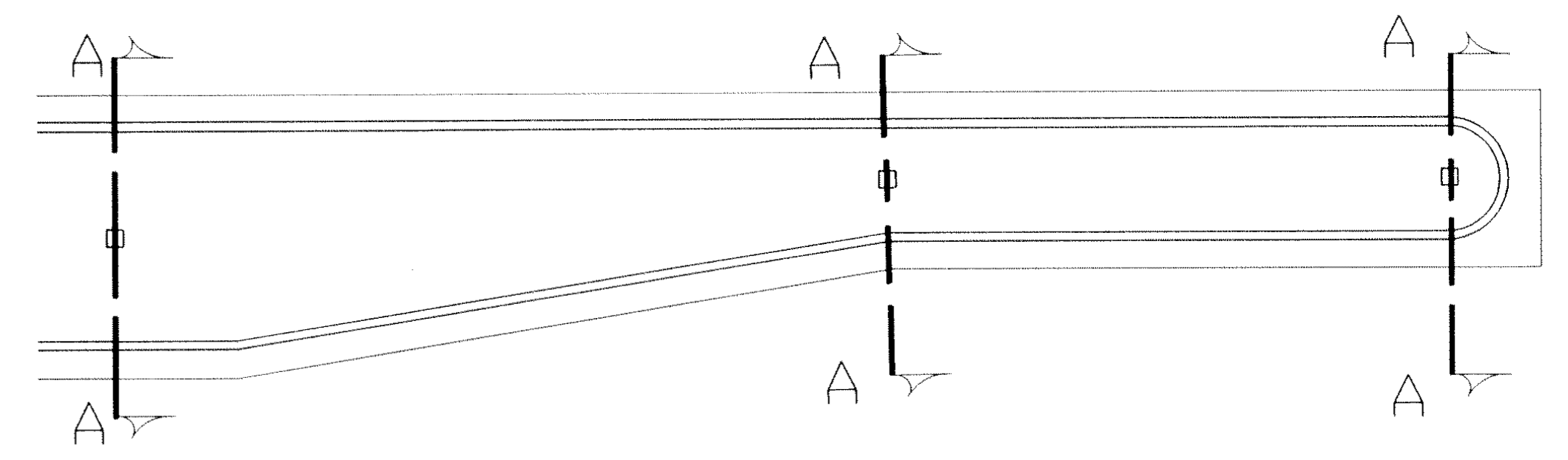
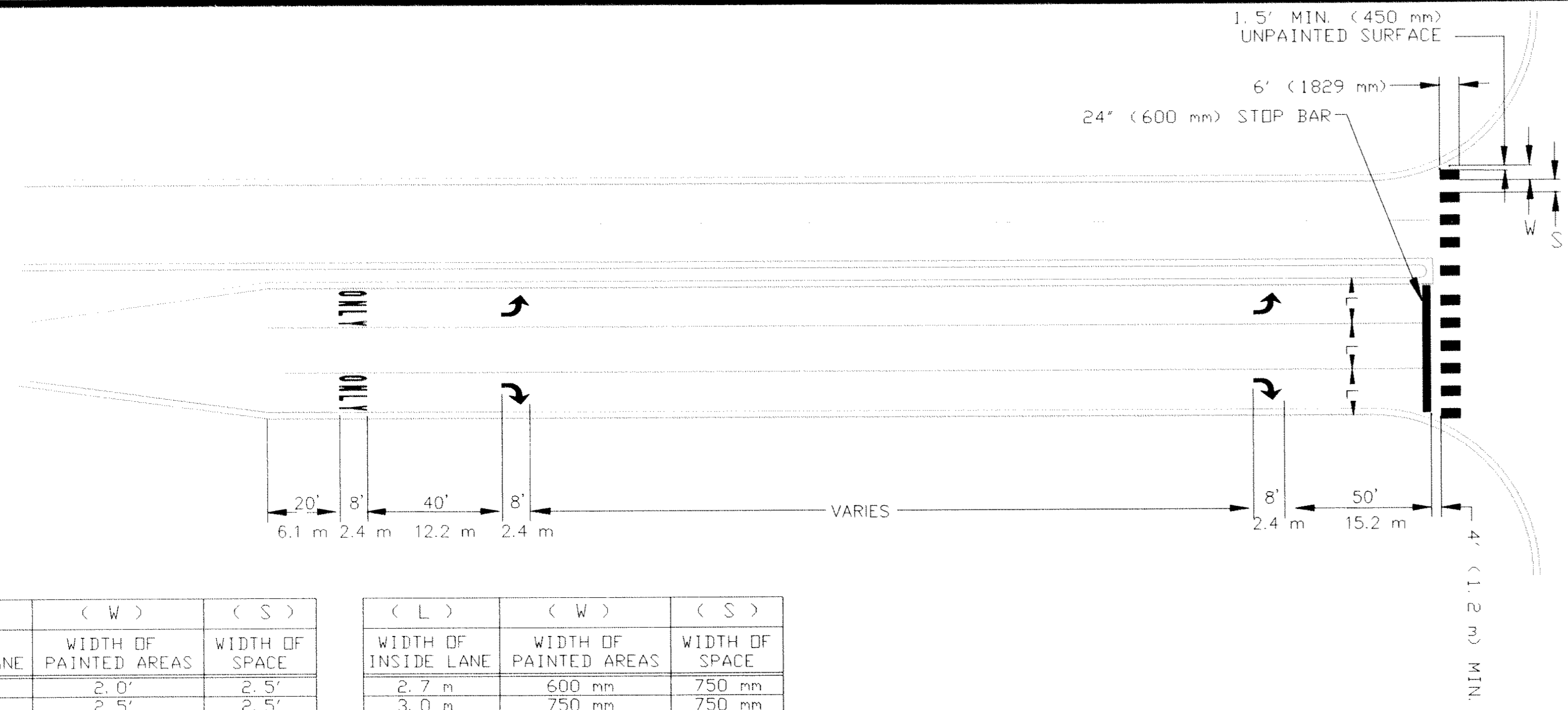

1 3/4" (45 mm) x 1 3/4" (45 mm) x 12" (30 mm) SOLID GALVANIZED SQUARE TUBING
SEE BELOW

(L)	(W)	(S)	(L)	(W)	(S)
WIDTH OF INSIDE LANE	WIDTH OF PAINTED AREAS	WIDTH OF SPACE	WIDTH OF INSIDE LANE	WIDTH OF PAINTED AREAS	WIDTH OF SPACE
9'	2.0'	2.5'	2.7 m	600 mm	750 mm
10'	2.5'	2.5'	3.0 m	750 mm	750 mm
11'	2.5'	3.0'	3.3 m	750 mm	900 mm
12'	3.0'	3.0'	3.6 m	900 mm	900 mm
13'	3.0'	3.5'	4.0 m	900 mm	1100 mm

NOTES: CROSSWALKS:

- 1.) PAINTED AREAS ARE TO BE CENTERED ON CENTER AND LANE LINES, EVEN IF INTERSECTION IS NOT ALIGNED.
- 2.) LOCATION OF ZEBRA CROSSWALKS AND STOP BARS, SIGNAL LOOPS AND PED RAMPS ARE APPROXIMATE. FINAL LOCATIONS ARE TO BE DETERMINED AND FIELD VERIFIED DURING CONSTRUCTION BY THE FIELD ENGR.
- 3.) ZEBRA CROSSWALKS ARE TO BE PARALLEL TO THE DRIVING LANE OR LANES, EVEN IF THE STREET IS ON AN ANGLE TO THE INTERSECTION.
- 4.) A MIN. OF 1.5' (450 mm) CLEAR DISTANCE MUST BE LEFT ADJACENT TO THE CURB. IF LAST PAINTED AREA FALLS INTO THIS AREA, IT MUST BE OMITTED.
- 5.) ON TWO LANE STREETS, USE SPACING SHOWN FOR AN 11' (3.3 m) INSIDE LANE.

GROUND POST MOUNT SIGN INSTALLATION TYPICAL

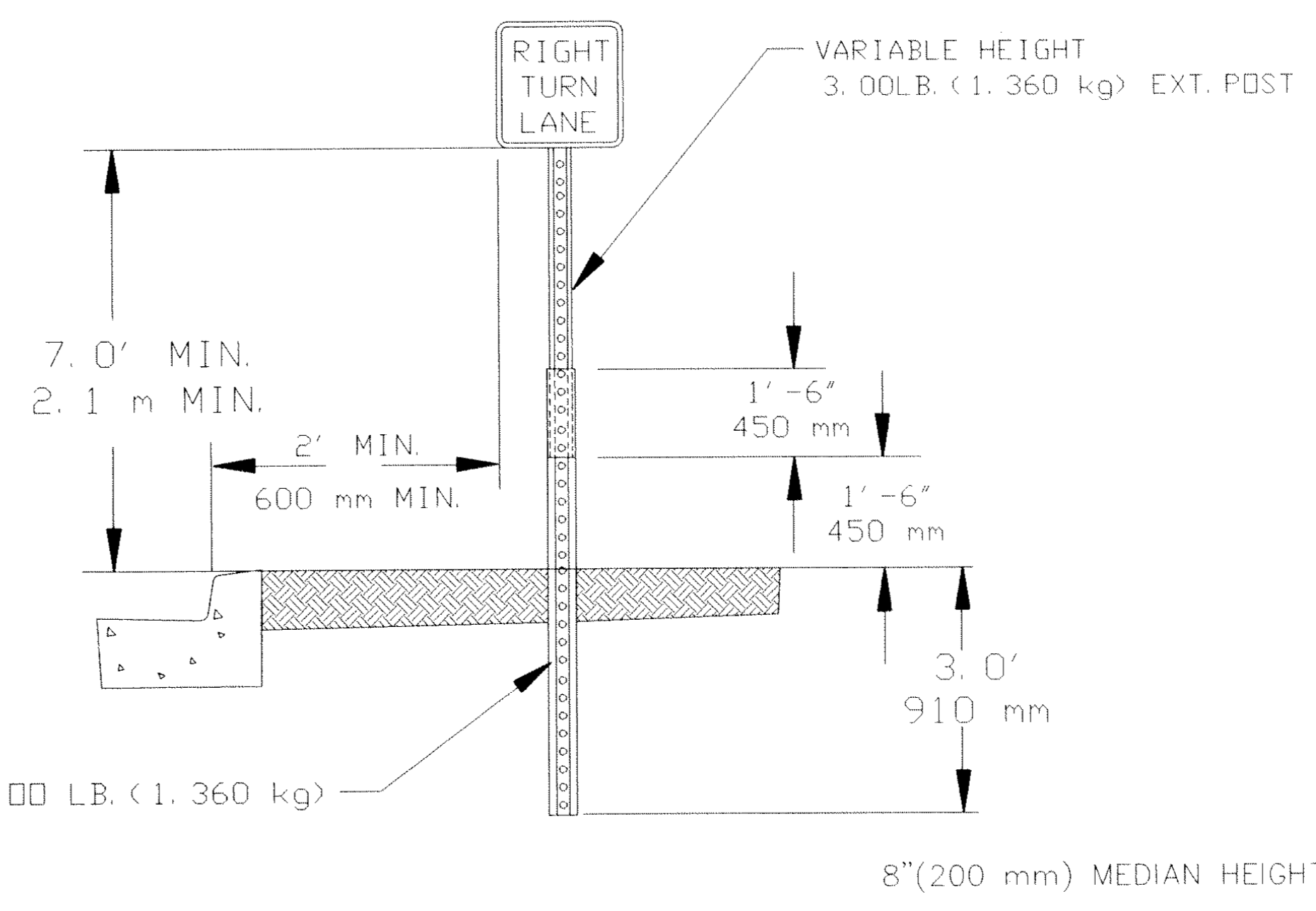

ISLAND MOUNT BREAK-AWAY SIGN INSTALLATION TYPICAL

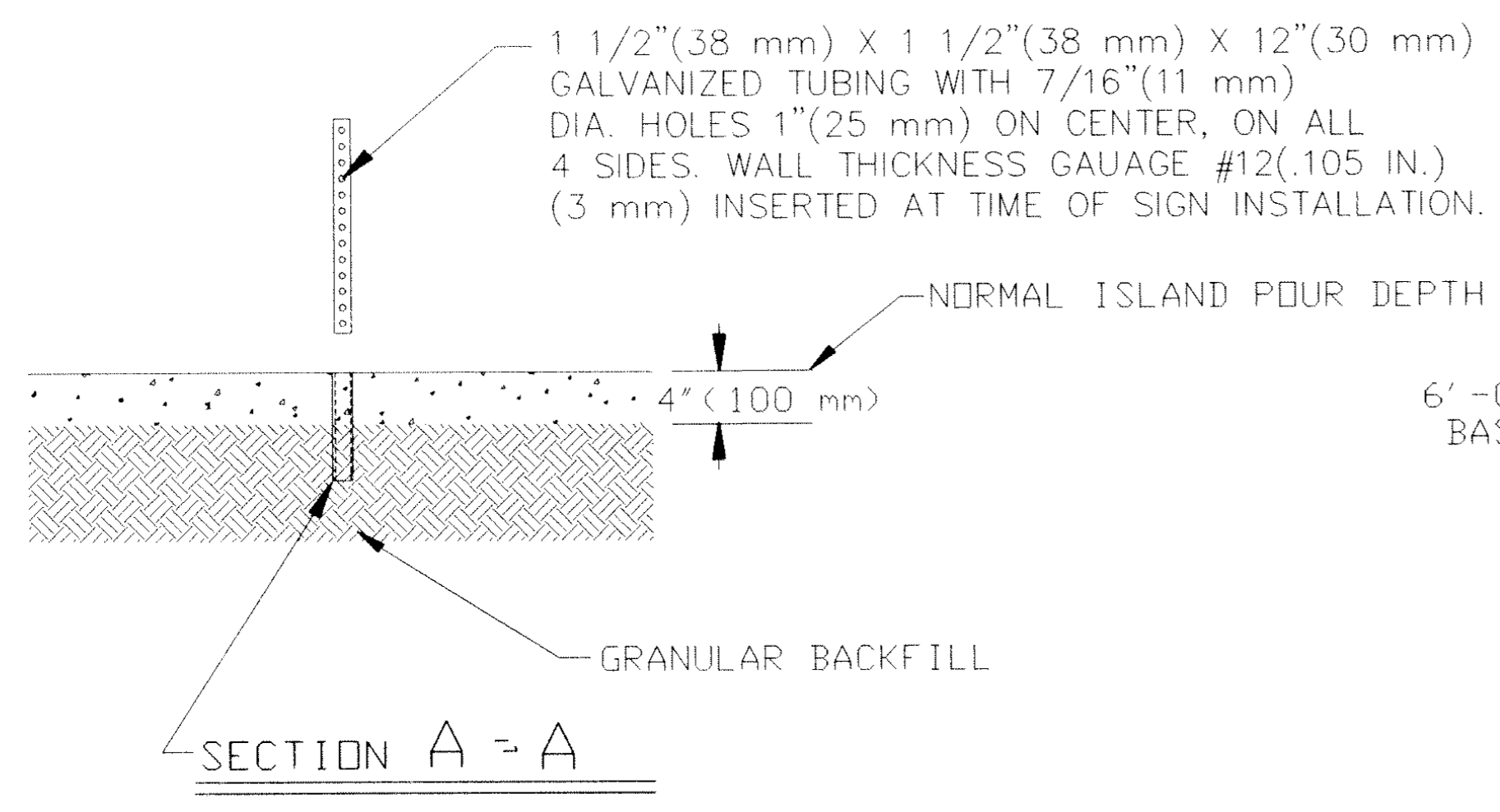
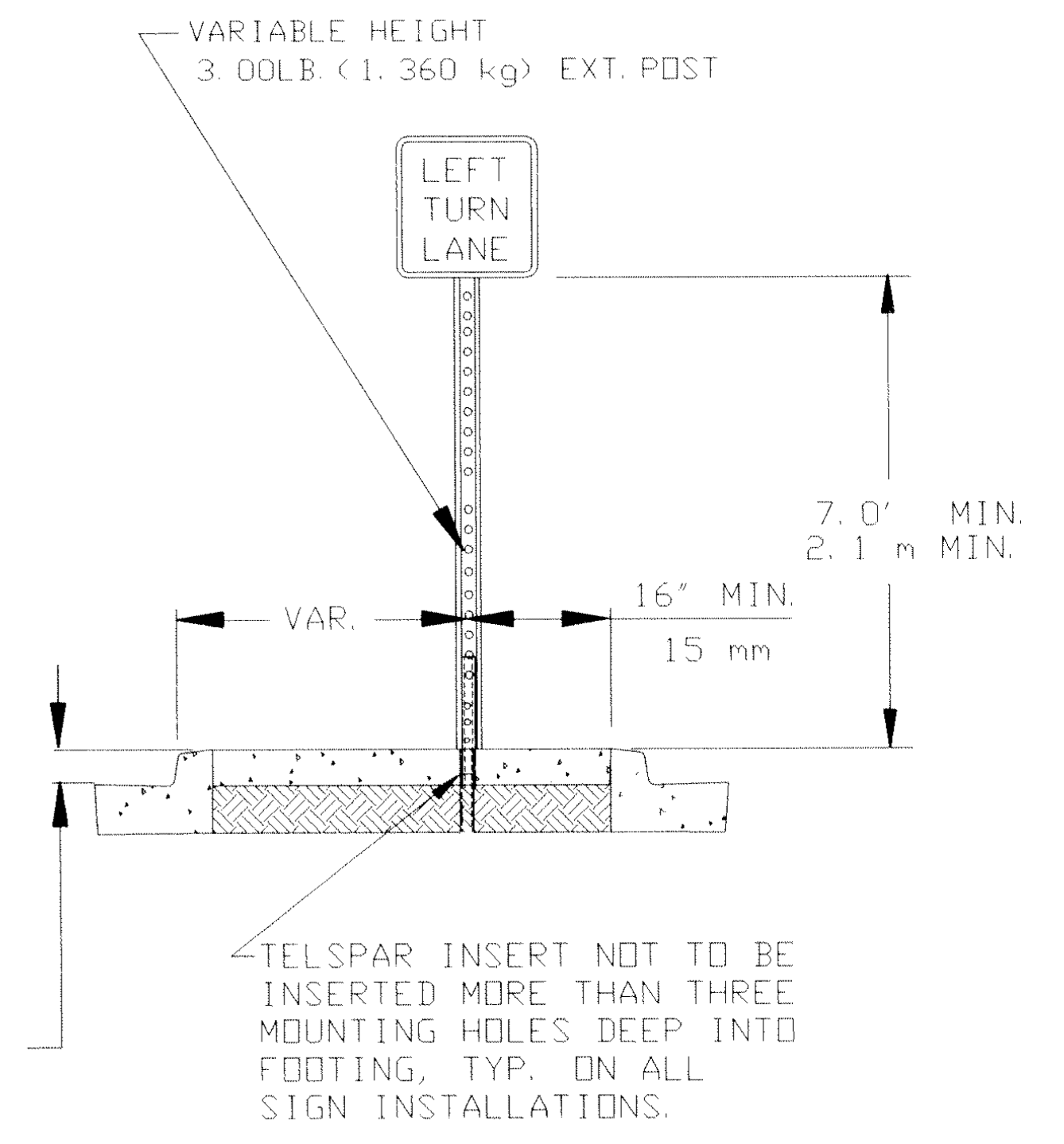

INSTALL 1 3/4" (45 mm) x 1 3/4" (45 mm) x 12" (25 mm) SOLID WALL GALVANIZED SQUARE TUBING BEFORE CONCRETE POUR. HAMMER INTO GROUND SO THAT 1" (25 mm) OF TUBE IS ABOVE TOP OF CURB. RE-PLUMB AT TIME OF POUR.

NO	DATE	BY	CKD	APPR	REVISION

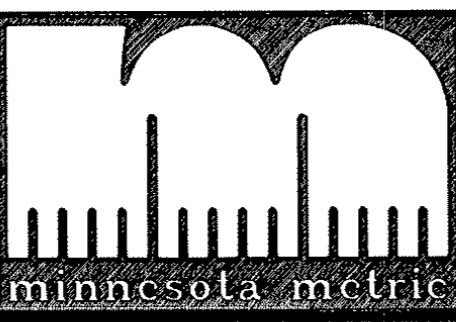

I HEREBY CERTIFY THAT THIS PLAN WAS PREPARED BY ME OR UNDER MY DIRECT SUPERVISION AND THAT I AM A DULY REGISTERED PROFESSIONAL ENGINEER UNDER THE LAWS OF THE STATE OF MINNESOTA.
DATE _____ REG. NO. _____

DRAWN BY _____ DATE _____
DESIGN BY _____ DATE _____
CHECKED BY _____ DATE _____



ANOKA COUNTY
HIGHWAY DEPT.

STATE PROJECT NO. 02-678-12/02-716-02
STATE AID PROJECT NO. _____
STATE AID PROJECT NO. _____
COUNTY PROJECT NO. _____

SIGNING
STRIPING DETAILS
Sheet 27 of 59 Sheets

M.U.T.C.D. CODE	SIZE		PANEL AREA		INSERT	QTY	MOUNTING POST PER INSTALLATION		MOUNTING HEIGHT	
	INCHES	FT. ²	m ²				FT.	m	FT.	m
R1-1	30" x 30"	6.25	0.58		STOP	11	1	7.0'	2.1	
R2-1	24" x 30"	5.00	0.46		SPEED LIMIT 50	1	1	7.0'	2.1	
R2-1	24" x 30"	5.00	0.46		SPEED LIMIT 55	3	1	7.0'	2.1	
R3-X1	30" x 30"	6.25	0.58		RIGHT TURN LANE	9	1	7.0'	2.1	
R3-X2	30" x 30"	6.25	0.58		LEFT TURN LANE	4	1	7.0'	2.1	
R3-4	24" x 24"	4.00	0.37			4				①
R4-7	24" x 30"	5.00	0.46			8	1	7.0'	2.1	
X4-2	18" x 18"					8				②
R5-1	30" x 30"	6.25	0.58		DO NOT ENTER	13	1	7.0'	2.1	④
R6-1R	36" x 12"	3.00	0.28		ONE WAY	5				③
R6-1R	36" x 12"	3.00	0.28		ONE WAY	5	2	7.0'	2.1	

M.U.T.C.D. CODE	SIZE		PANEL AREA		INSERT	QTY	MOUNTING POST PER INSTALLATION		MOUNTING HEIGHT	
	INCHES	FT. ²	m ²				FT.	m	FT.	m
W1-4L	36" x 36"	9.00	0.84			1	2U-1A	7.0'	2.1	
W3-3	36" x 36"	9.00	0.84			4	2U-1A	7.0'	2.1	
X4-4L	12" x 36"					4	1	5.0'	1.5	
M2-1A	21" x 15"	2.18	0.20		JCT	2				
M3-1A	24" x 12"	2.00	0.19		NORTH	1				
M3-3A	24" x 12"	2.00	0.19		SOUTH	1				
M1-6A	24" x 24"	4.00	0.37		ANOKA COUNTY 78	6	1	7.0'	2.1	
M6-4A	21" x 15"	2.18	0.20			2				
M2-1A	21" x 15"	2.18	0.20		JCT	2				
M3-2A	24" x 12"	2.00	0.19		EAST	1				
M3-4A	24" x 12"	2.00	0.19		WEST	1				
M1-6A	24" x 24"	4.00	0.37		ANOKA COUNTY 116	6	1	7.0'	2.1	
M6-4A	21" x 15"	2.18	0.20			2				

* NOTE:
 ① MOUNTED BEHIND R4-7
 ② MOUNTED BELOW R4-7
 ③ MOUNTED ABOVE R1-1
 ④ 2 MOUNTED BACK TO BACK

NOTE:
 1) LOCATIONS OF 'NO PASSING ZONES' ARE APPROXIMATE. EXACT LOCATIONS WILL BE DETERMINED IN THE FIELD.
 2) ALL TRAFFIC CONTROL DEVICES SHALL CONFORM TO THE MINNESOTA MANUAL ON TRAFFIC CONTROL DEVICES, INCLUDING THE FIELD MANUAL DATED JANUARY, 1998

NO	DATE	BY	CKD	APPR	REVISION

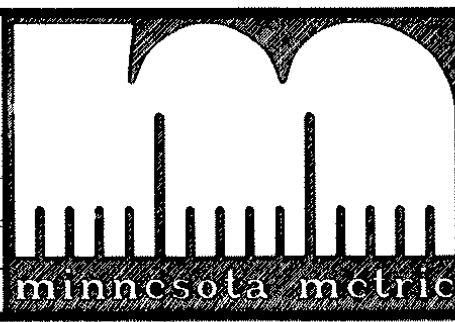

I HEREBY CERTIFY THAT THIS PLAN WAS PREPARED BY ME OR UNDER MY DIRECT SUPERVISION AND THAT I AM A DULY REGISTERED PROFESSIONAL ENGINEER UNDER THE LAWS OF THE STATE OF MINNESOTA.
 DATE _____ REG. NO. _____

DRAWN BY _____ DATE _____
 DESIGN BY _____ DATE _____
 CHECKED BY _____ DATE _____

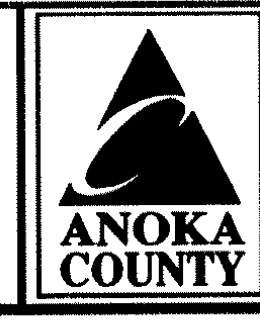

ANOKA COUNTY
 HIGHWAY DEPT.

STATE PROJECT NO. 02-678-12/02-716-02
 STATE PROJECT NO. _____
 STATE AID PROJECT NO. _____
 COUNTY PROJECT NO. _____

PERMANENT
 SIGN QUANTITIES
 Sheet 26 of 59 Sheets

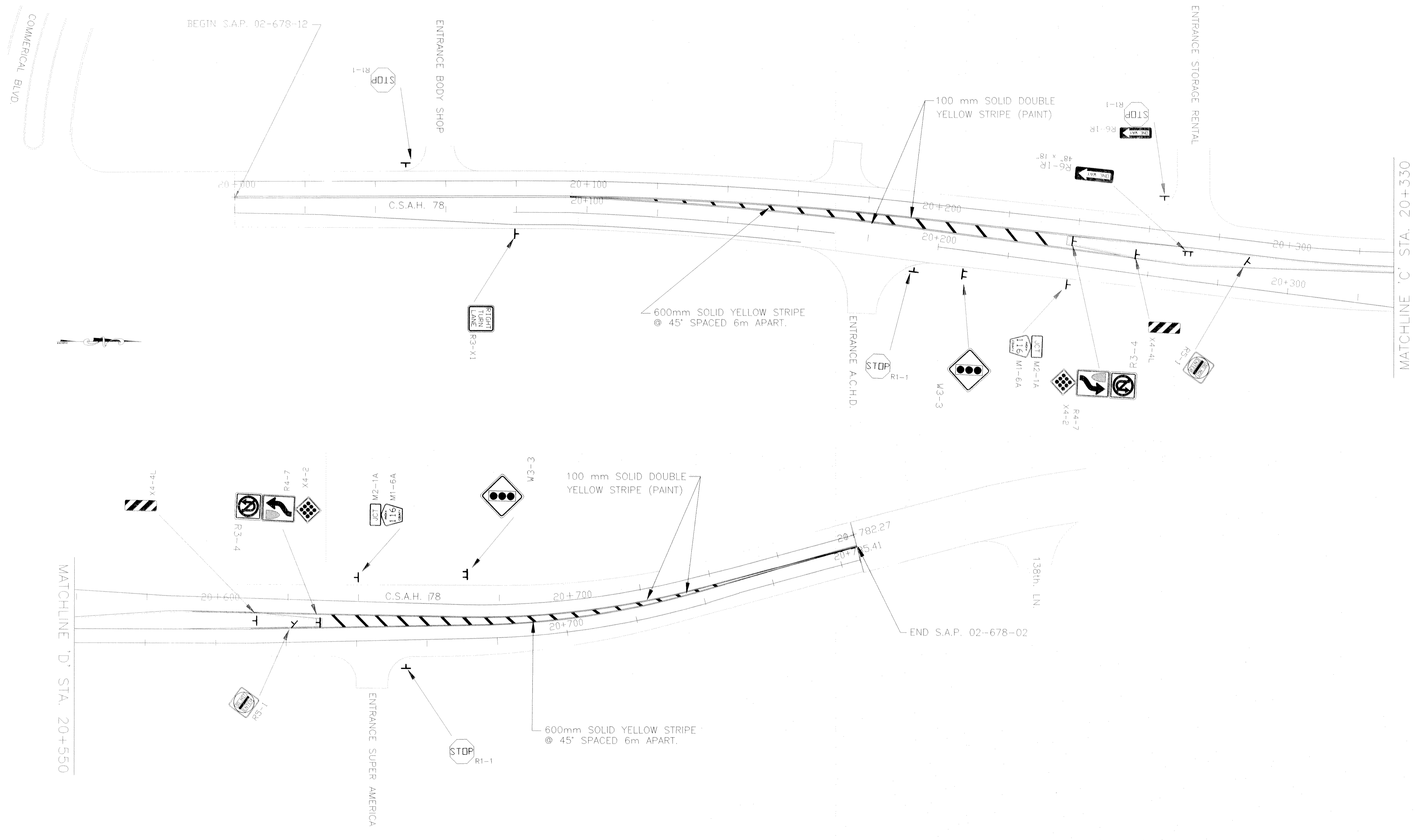

NO	DATE	BY	CKD	APPR	REVISION

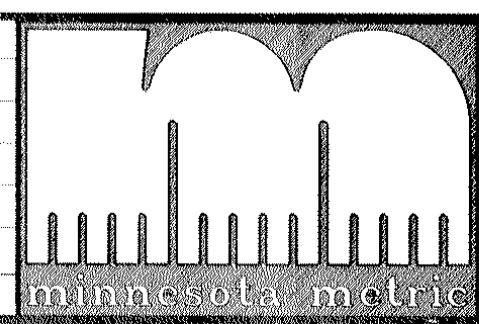

I HEREBY CERTIFY THAT THIS PLAN WAS PREPARED BY ME OR UNDER MY DIRECT SUPERVISION AND THAT I AM A DULY REGISTERED PROFESSIONAL ENGINEER UNDER THE LAWS OF THE STATE OF MINNESOTA.

DATE _____ REG. NO. _____

DRAWN BY _____ DATE _____
 DESIGN BY _____ DATE _____
 CHECKED BY _____ DATE _____

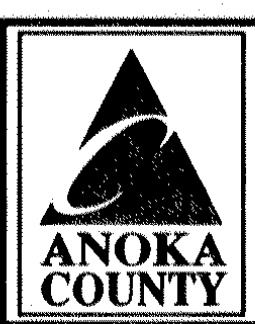

**ANOKA COUNTY
HIGHWAY DEPT.**

STATE PROJECT NO. 02-678-12/02-716-02
 STATE PROJECT NO. _____
 STATE AID PROJECT NO. _____
 COUNTY PROJECT NO. _____

**PERMANENT
SIGN / STRIPE**

Sheet 25 of 59 Sheets

BEGIN S.P. 02-678-12
STA. 2+010.00

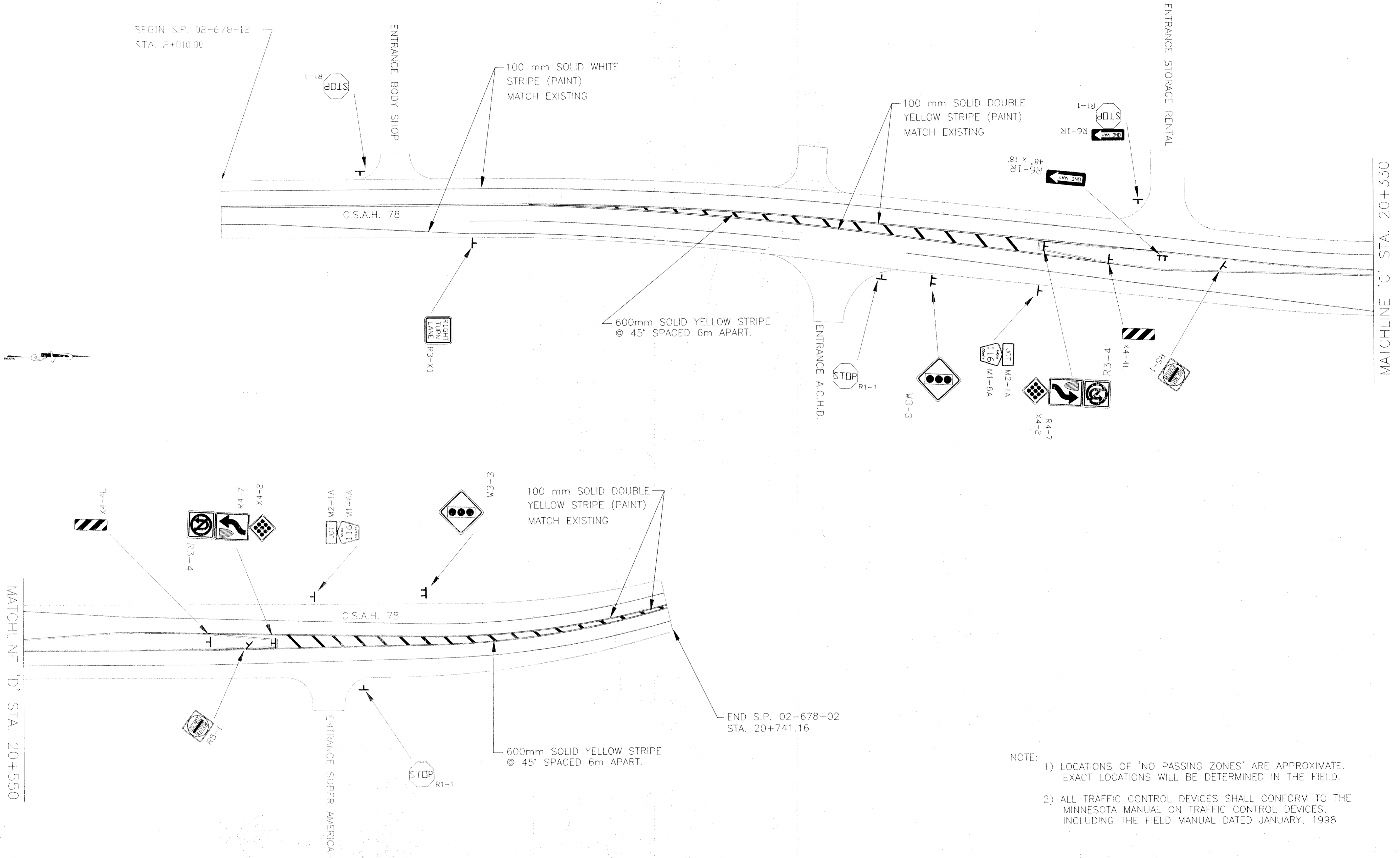

- NOTE:
- 1) LOCATIONS OF 'NO PASSING ZONES' ARE APPROXIMATE. EXACT LOCATIONS WILL BE DETERMINED IN THE FIELD.
 - 2) ALL TRAFFIC CONTROL DEVICES SHALL CONFORM TO THE MINNESOTA MANUAL ON TRAFFIC CONTROL DEVICES, INCLUDING THE FIELD MANUAL DATED JANUARY, 1998

NO	DATE	BY	CKD	APPR	REVISION

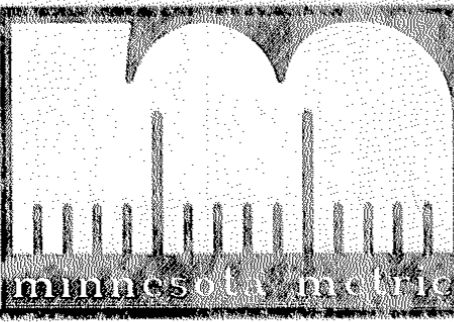

I HEREBY CERTIFY THAT THIS PLAN WAS PREPARED BY ME OR UNDER MY DIRECT SUPERVISION AND THAT I AM A DULY REGISTERED PROFESSIONAL ENGINEER UNDER THE LAWS OF THE STATE OF MINNESOTA.

DATE _____ REG. NO. _____

DRAWN BY _____ DATE _____
 DESIGN BY _____ DATE _____
 CHECKED BY _____ DATE _____



**ANOKA COUNTY
HIGHWAY DEPT.**

STATE PROJECT NO. **02-678-12/02-716-02**
 STATE PROJECT NO. _____
 STATE AID PROJECT NO. _____
 COUNTY PROJECT NO. _____

**PERMANENT
SIGN / STRIPE**

Sheet **25** of **59** Sheets

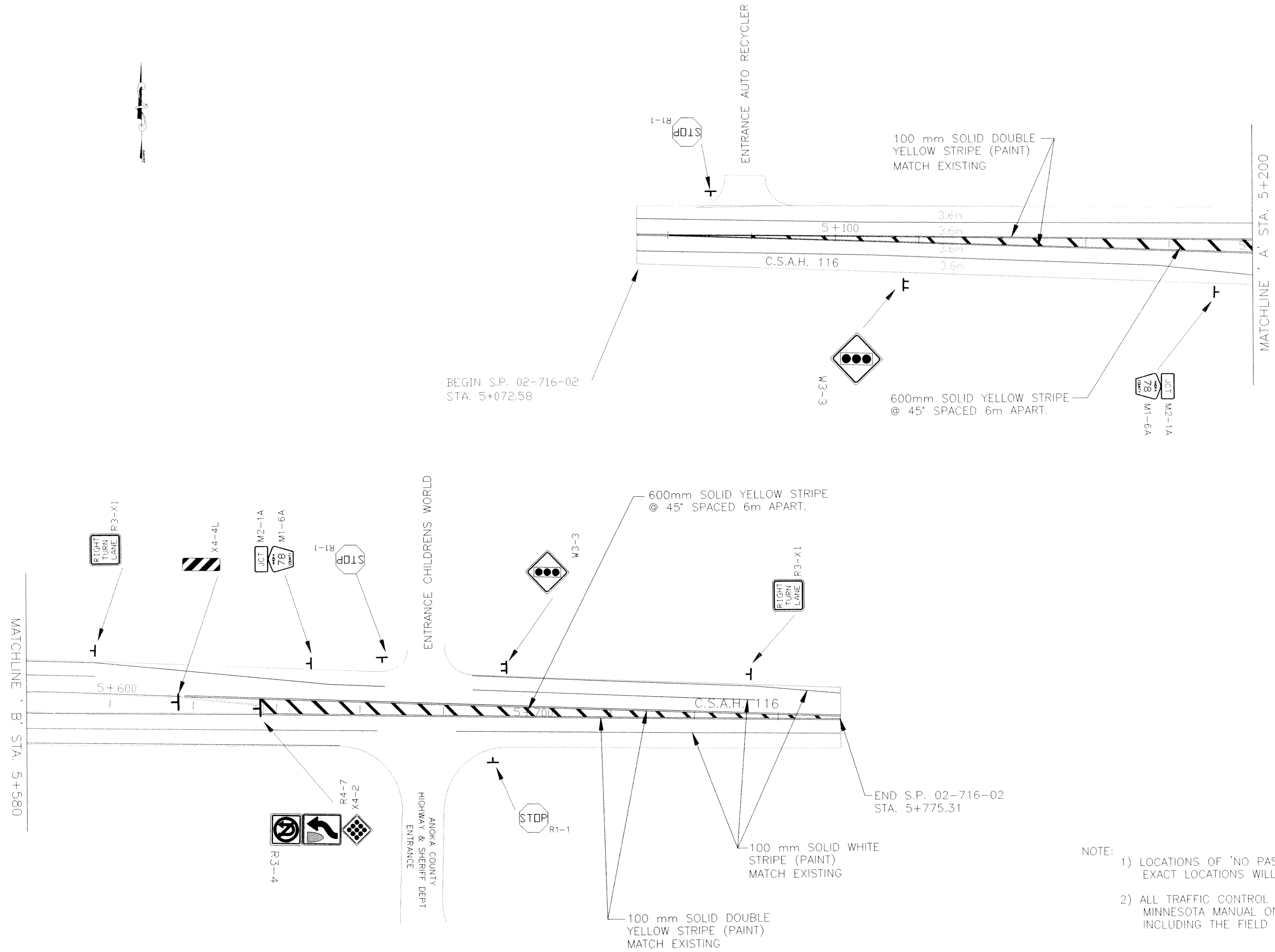

NOTE:
 1) LOCATIONS OF 'NO PASSING ZONES' ARE APPROXIMATE. EXACT LOCATIONS WILL BE DETERMINED IN THE FIELD.
 2) ALL TRAFFIC CONTROL DEVICES SHALL CONFORM TO THE MINNESOTA MANUAL ON TRAFFIC CONTROL DEVICES, INCLUDING THE FIELD MANUAL DATED JANUARY, 1998

NO	DATE	BY	CKD	APPR	REVISION

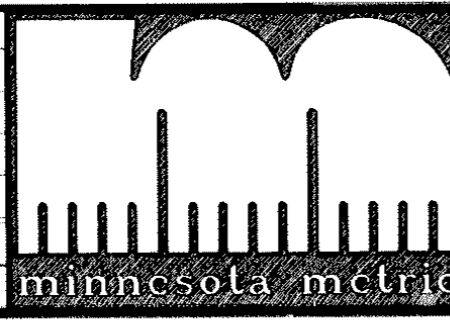

I HEREBY CERTIFY THAT THIS PLAN WAS PREPARED BY ME OR UNDER MY DIRECT SUPERVISION AND THAT I AM A DULY REGISTERED PROFESSIONAL ENGINEER UNDER THE LAWS OF THE STATE OF MINNESOTA.
 DATE _____ REG. NO. _____

DRAWN BY _____ DATE _____
 DESIGN BY _____ DATE _____
 CHECKED BY _____ DATE _____



**ANOKA COUNTY
 HIGHWAY DEPT.**

STATE PROJECT NO. 02-678-12/02-716-02
 STATE PROJECT NO. _____
 STATE AID PROJECT NO. _____
 COUNTY PROJECT NO. _____

PERMANENT
 SIGN / STRIPE
 Sheet 24 of 59 Sheets

① 35' WOOD POLE-CL-2
TYPE IOA POLE MOUNTED AT 90°
TYPE IOA POLE MOUNTED AT 270°
2-DOWN GUY, GUARD, AND ANCHOR
JUNCTION BOX #1
2" RSC RISER AND WEATHERHEAD
2-12/C #12
3-2/C #14
11/4" RSC RISER BELOW J.B. 1 EXTENDED
INTO HH 14 WITH:
3-2/C #14

② 35' WOOD POLE-CL-2
TYPE IOA POLE MOUNTED AT 90°
TYPE IOA POLE MOUNTED AT 270°
2-DOWN GUY, GUARD, AND ANCHOR
LUMINAIRE-200 WATT H.P.S.
JUNCTION BOX #2
2-2" RSC RISERS AND WEATHERHEADS
EXTENDED INTO HH 1 WITH:
5-12/C #12
9-2/C #14
2-1/C #10
1-6 PR #19

③ 35' WOOD POLE-CL-2
TYPE IOA POLE MOUNTED AT 90°
TYPE IOA POLE MOUNTED AT 270°
2-DOWN GUY, GUARD, AND ANCHOR
JUNCTION BOX #3
2" RSC RISER AND WEATHERHEAD
1-12/C #12
3-2/C #14
11/4" RSC RISER BELOW J.B. 3 EXTENDED
INTO HH 3 WITH:
3-2/C #14

④ 35' WOOD POL-CL-2
TYPE IOA POLE MOUNTED AT 90°
TYPE IOA POLE MOUNTED AT 270°
2-DOWN GUY, GUARD, AND ANCHOR
LUMINAIRE-200 WATT H.P.S.
JUNCTION BOX #4
2" RSC RISER AND WEATHERHEAD
1-12/C #12
3-2/C #14
2-1/C #10
1-6 PR #19
11/4" RSC RISER BELOW J.B. 4 EXTENDED
INTO HH 4 WITH:
3-2/C #14
1-6 PR #19

Ⓐ CONTROLLER AND CABINET
CABINET FOUNDATION
EXTEND 3" RSC INTO HH1 WITH:
5-12/C #12
9-2/C #14
1-6 PR #19
EXTEND INTO HH 5
METERED SIGNAL SERVICE
1 1/4" RSC
3-1/C #6
11/4" RSC
2-1/C #10
STUB OUT 2" RSC (FOR SERVICE BY OTHERS)
BETWEEN HH 5 AND HH 1:
1 1/4" RSC
2-1/C #10

Ⓑ SERVICE CABINET
CABINET FOUNDATION
EXTEND INTO HH 5
METERED SIGNAL SERVICE
1 1/4" RSC
3-1/C #6
11/4" RSC
2-1/C #10
STUB OUT 2" RSC (FOR SERVICE BY OTHERS)
BETWEEN HH 5 AND HH 1:
1 1/4" RSC
2-1/C #10

NOTES:

- 1) SEE SPECIAL PROVISIONS FOR CONTRACTOR'S RESPONSIBILITY FOR LOCATION OF UTILITIES.
- 2) ALL SIGNAL FACES SHALL HAVE BACKGROUND SHIELDS.
- 3) LUMINAIRE AT LOCATION 2 SHALL INCLUDE P.E.C. AND CHECK SWITCH.
- 4) SEE SPECIAL PROVISIONS FOR ANOKA COUNTY SERVICE CABINET DETAILS.
- 5) HANDHOLES SHALL BE CONCRETE WITH CONCRETE COVERS.
- 6) LOOP DETECTOR WIRES SHALL BE CROSS LINKED POLYETHYLENE (XLP) IN 1" N.M.C. SEE SPECIAL PROVISIONS.
- 7) CONTRACTOR SHALL INSTALL COUNTY FURNISHED CONTROLLER AND CABINET. SEE SPECIAL PROVISIONS.
- 8) CONTRACTOR SHALL SEED AREAS DISTURBED DURING CONSTRUCTION. SEE SPECIAL PROVISIONS.
- 9) CONTRACTOR SHALL FURNISH AND INSTALL TRAFFIC SIGNAL SOFTWARE AND INTERCONNECT CABLE TO PROVIDE COMMUNICATION BETWEEN SIGNAL SYSTEM "B" AND A COUNTY-FURNISHED TRAFFIC SIGNAL COMPUTER LOCATED IN THE COUNTY'S PUBLIC WORKS SHOP. SEE SPECIAL PROVISIONS.

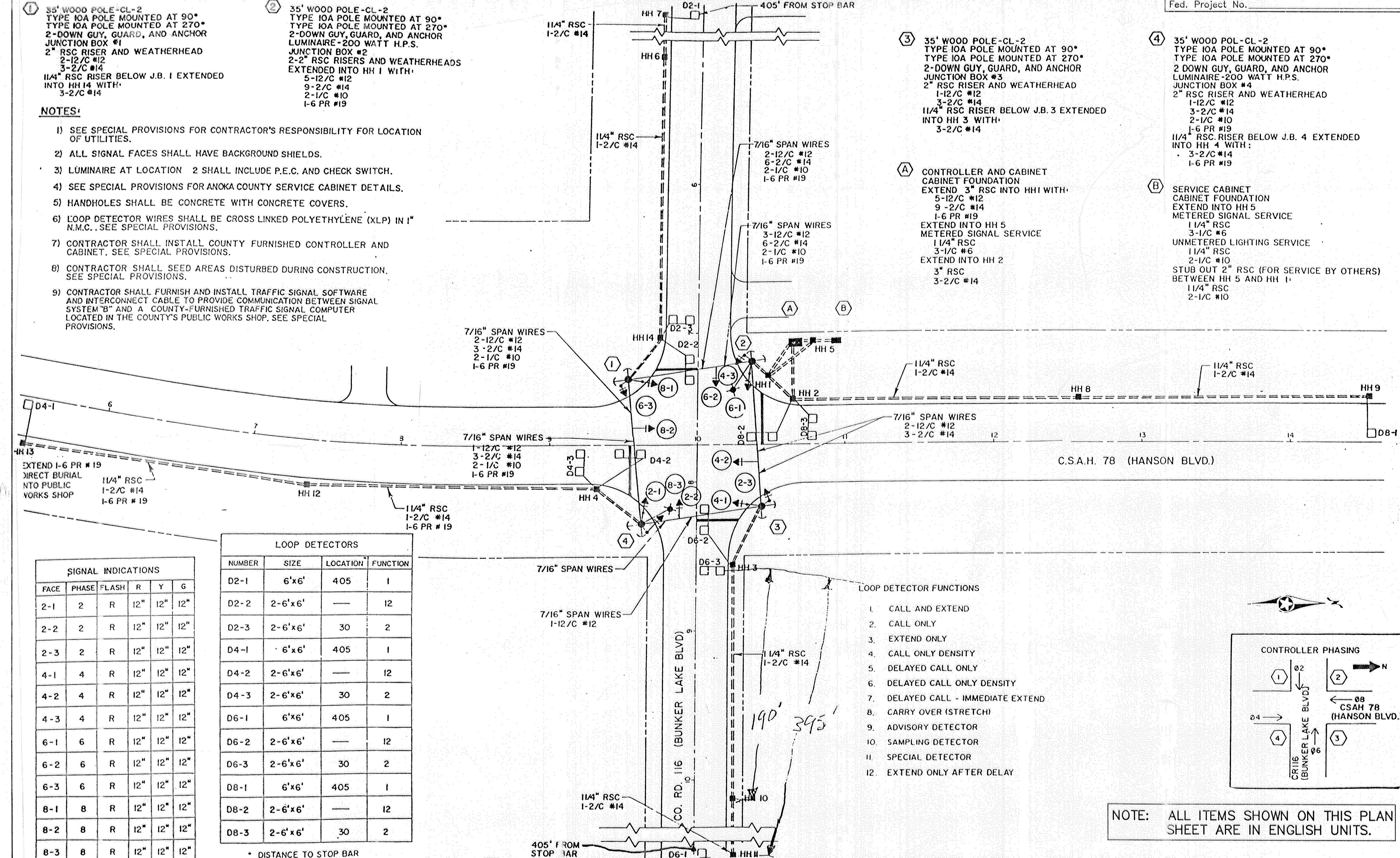

SIGNAL INDICATIONS						
FACE	PHASE	FLASH	R	Y	G	
2-1	2	R	12"	12"	12"	
2-2	2	R	12"	12"	12"	
2-3	2	R	12"	12"	12"	
4-1	4	R	12"	12"	12"	
4-2	4	R	12"	12"	12"	
4-3	4	R	12"	12"	12"	
6-1	6	R	12"	12"	12"	
6-2	6	R	12"	12"	12"	
6-3	6	R	12"	12"	12"	
8-1	8	R	12"	12"	12"	
8-2	8	R	12"	12"	12"	
8-3	8	R	12"	12"	12"	

LOOP DETECTORS				
NUMBER	SIZE	LOCATION	FUNCTION	
D2-1	6'x6'	405	1	
D2-2	2-6'x6'	—	12	
D2-3	2-6'x6'	30	2	
D4-1	6'x6'	405	1	
D4-2	2-6'x6'	—	12	
D4-3	2-6'x6'	30	2	
D6-1	6'x6'	405	1	
D6-2	2-6'x6'	—	12	
D6-3	2-6'x6'	30	2	
D8-1	6'x6'	405	1	
D8-2	2-6'x6'	—	12	
D8-3	2-6'x6'	30	2	

• DISTANCE TO STOP BAR

- LOOP DETECTOR FUNCTIONS**
1. CALL AND EXTEND
 2. CALL ONLY
 3. EXTEND ONLY
 4. CALL ONLY DENSITY
 5. DELAYED CALL ONLY
 6. DELAYED CALL ONLY DENSITY
 7. DELAYED CALL - IMMEDIATE EXTEND
 8. CARRY OVER (STRETCH)
 9. ADVISORY DETECTOR
 10. SAMPLING DETECTOR
 11. SPECIAL DETECTOR
 12. EXTEND ONLY AFTER DELAY

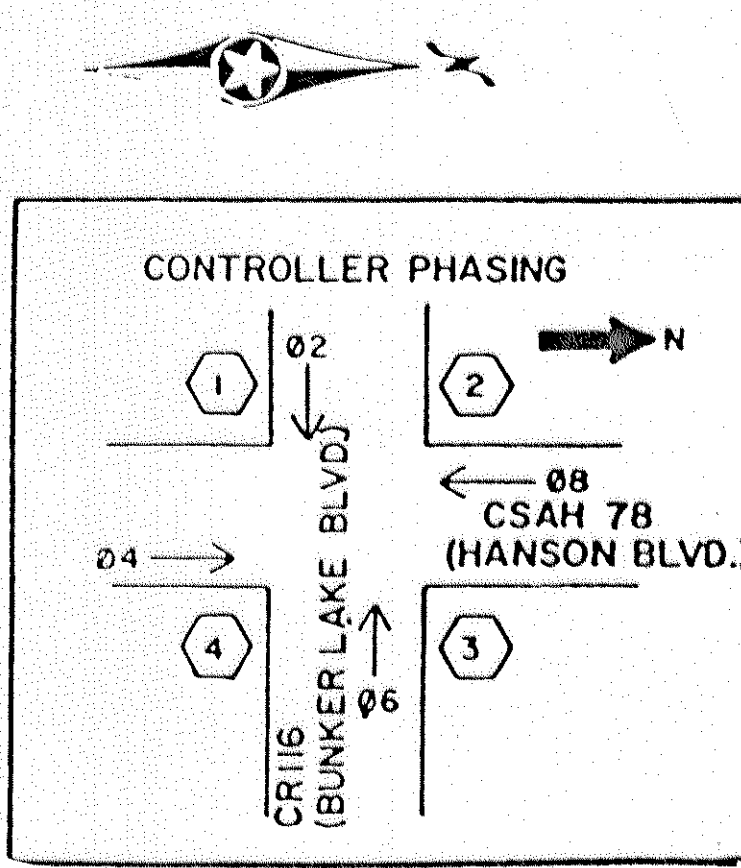

NOTE: ALL ITEMS SHOWN ON THIS PLAN SHEET ARE IN ENGLISH UNITS.

NO.	BY	DATE	REVISIONS	ITEM	DESIGN	CHECKED

I hereby certify that this plan was prepared by me or under my direct supervision and that I am a duly Registered Professional Engineer under the laws of the state of Minnesota.
Date: 11/21/98 Reg. No. 22457

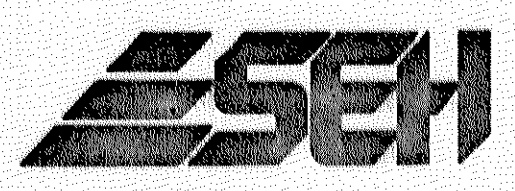

ANOKA COUNTY, MINNESOTA
CITY OF ANDOVER
S.P. 02-678-12
S.P. 02-716-02

TRAFFIC SIGNAL SYSTEM
FOR INFORMATION ONLY
HANSON BOULEVARD NW (CSAH 78) AT
BUNKER LAKE BOULEVARD NW (CSAH 116)

FILE NO.
ANOKC9708
DATE
3/16/98
22
59

① 35' WOOD POLE-CL-2
TYPE IOA POLE MOUNTED AT 90°
TYPE IOA POLE MOUNTED AT 270°
2-DOWN GUY, GUARD, AND ANCHOR
JUNCTION BOX #1
2" RSC RISER AND WEATHERHEAD
2-12/C #12
3-2/C #14
11/4" RSC RISER BELOW J.B. 1 EXTENDED
INTO HH 14 WITH:
3-2/C #14

② 35' WOOD POLE-CL-2
TYPE IOA POLE MOUNTED AT 90°
TYPE IOA POLE MOUNTED AT 270°
2-DOWN GUY, GUARD, AND ANCHOR
LUMINAIRE-200 WATT H.P.S.
JUNCTION BOX #2
2-2" RSC RISERS AND WEATHERHEADS
EXTENDED INTO HH 1 WITH:
5-12/C #12
9-2/C #14
2-1/C #10
1-6 PR #19

③ 35' WOOD POLE-CL-2
TYPE IOA POLE MOUNTED AT 90°
TYPE IOA POLE MOUNTED AT 270°
2-DOWN GUY, GUARD, AND ANCHOR
JUNCTION BOX #3
2" RSC RISER AND WEATHERHEAD
1-12/C #12
3-2/C #14
11/4" RSC RISER BELOW J.B. 3 EXTENDED
INTO HH 3 WITH:
3-2/C #14

④ 35' WOOD POL-CL-2
TYPE IOA POLE MOUNTED AT 90°
TYPE IOA POLE MOUNTED AT 270°
2 DOWN GUY, GUARD, AND ANCHOR
LUMINAIRE-200 WATT H.P.S.
JUNCTION BOX #4
2" RSC RISER AND WEATHERHEAD
1-12/C #12
3-2/C #14
2-1/C #10
1-6 PR #19
11/4" RSC RISER BELOW J.B. 4 EXTENDED
INTO HH 4 WITH:
3-2/C #14
1-6 PR #19

NOTES:

- 1) SEE SPECIAL PROVISIONS FOR CONTRACTOR'S RESPONSIBILITY FOR LOCATION OF UTILITIES.
- 2) ALL SIGNAL FACES SHALL HAVE BACKGROUND SHIELDS.
- 3) LUMINAIRE AT LOCATION 2 SHALL INCLUDE P.E.C. AND CHECK SWITCH.
- 4) SEE SPECIAL PROVISIONS FOR ANOKA COUNTY SERVICE CABINET DETAILS.
- 5) HANDHOLES SHALL BE CONCRETE WITH CONCRETE COVERS.
- 6) LOOP DETECTOR WIRES SHALL BE CROSS LINKED POLYETHYLENE (XLP) IN 1" N.M.C.. SEE SPECIAL PROVISIONS.
- 7) CONTRACTOR SHALL INSTALL COUNTY FURNISHED CONTROLLER AND CABINET. SEE SPECIAL PROVISIONS.
- 8) CONTRACTOR SHALL SEED AREAS DISTURBED DURING CONSTRUCTION. SEE SPECIAL PROVISIONS.
- 9) CONTRACTOR SHALL FURNISH AND INSTALL TRAFFIC SIGNAL SOFTWARE AND INTERCONNECT CABLE TO PROVIDE COMMUNICATION BETWEEN SIGNAL SYSTEM "B" AND A COUNTY-FURNISHED TRAFFIC SIGNAL COMPUTER LOCATED IN THE COUNTY'S PUBLIC WORKS SHOP. SEE SPECIAL PROVISIONS.

Ⓐ CONTROLLER AND CABINET
CABINET FOUNDATION
EXTEND 3" RSC INTO HHI WITH:
5-12/C #12
9-2/C #14
1-6 PR #19
EXTEND INTO HH 5
METERED SIGNAL SERVICE
1 1/4" RSC
3-1/C #6
EXTEND INTO HH 2
3" RSC
3-2/C #14

Ⓑ SERVICE CABINET
CABINET FOUNDATION
EXTEND INTO HH 5
METERED SIGNAL SERVICE
1 1/4" RSC
3-1/C #6
UNMETERED LIGHTING SERVICE
1 1/4" RSC
2-1/C #10
STUB OUT 2" RSC (FOR SERVICE BY OTHERS)
BETWEEN HH 5 AND HH 1:
1 1/4" RSC
2-1/C #10

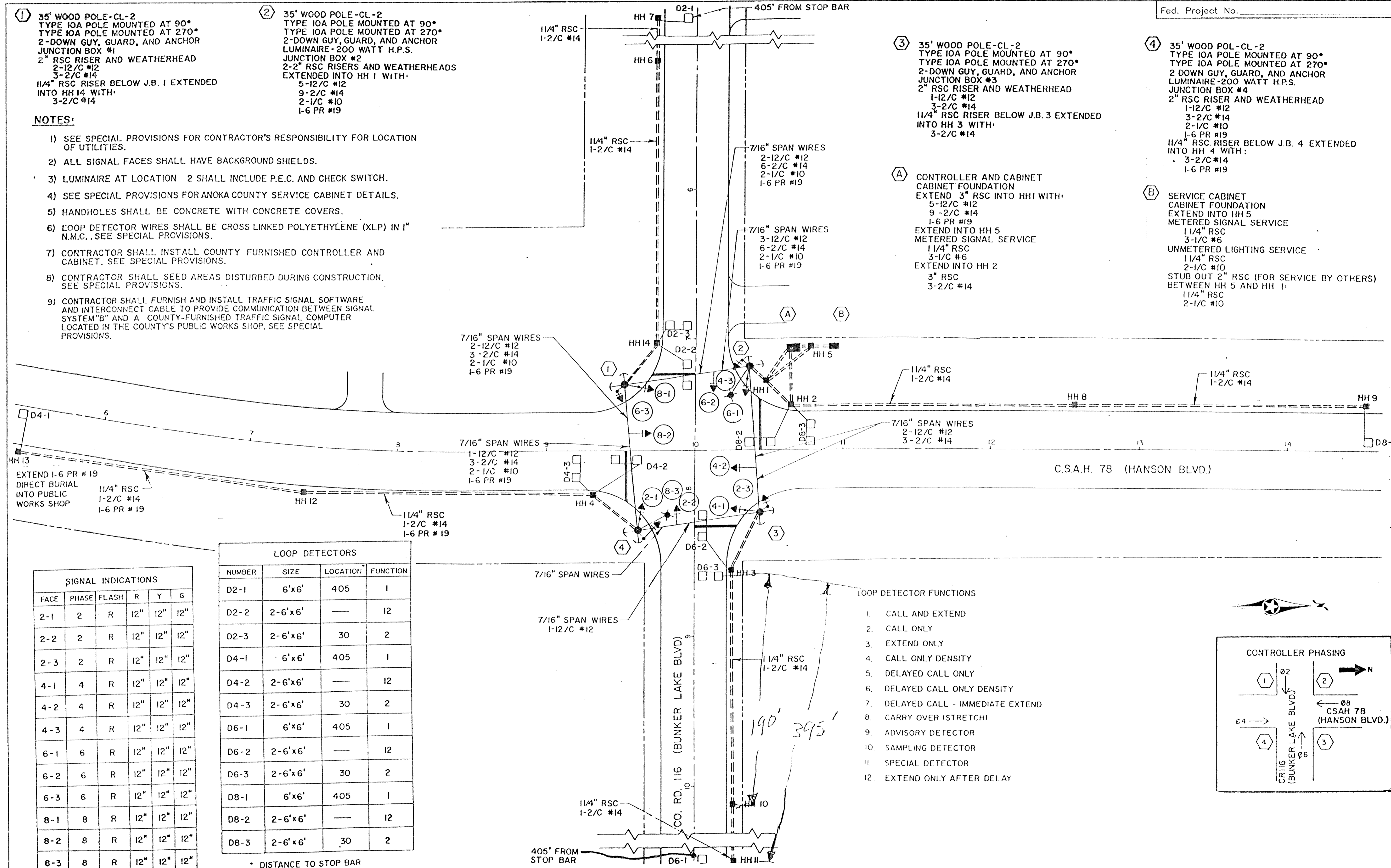

SIGNAL INDICATIONS					
FACE	PHASE	FLASH	R	Y	G
2-1	2	R	12"	12"	12"
2-2	2	R	12"	12"	12"
2-3	2	R	12"	12"	12"
4-1	4	R	12"	12"	12"
4-2	4	R	12"	12"	12"
4-3	4	R	12"	12"	12"
6-1	6	R	12"	12"	12"
6-2	6	R	12"	12"	12"
6-3	6	R	12"	12"	12"
8-1	8	R	12"	12"	12"
8-2	8	R	12"	12"	12"
8-3	8	R	12"	12"	12"

LOOP DETECTORS			
NUMBER	SIZE	LOCATION	FUNCTION
D2-1	6'x6'	405	1
D2-2	2-6'x6'	—	12
D2-3	2-6'x6'	30	2
D4-1	6'x6'	405	1
D4-2	2-6'x6'	—	12
D4-3	2-6'x6'	30	2
D6-1	6'x6'	405	1
D6-2	2-6'x6'	—	12
D6-3	2-6'x6'	30	2
D8-1	6'x6'	405	1
D8-2	2-6'x6'	—	12
D8-3	2-6'x6'	30	2

* DISTANCE TO STOP BAR

- LOOP DETECTOR FUNCTIONS**
1. CALL AND EXTEND
 2. CALL ONLY
 3. EXTEND ONLY
 4. CALL ONLY DENSITY
 5. DELAYED CALL ONLY
 6. DELAYED CALL ONLY DENSITY
 7. DELAYED CALL - IMMEDIATE EXTEND
 8. CARRY OVER (STRETCH)
 9. ADVISORY DETECTOR
 10. SAMPLING DETECTOR
 11. SPECIAL DETECTOR
 12. EXTEND ONLY AFTER DELAY

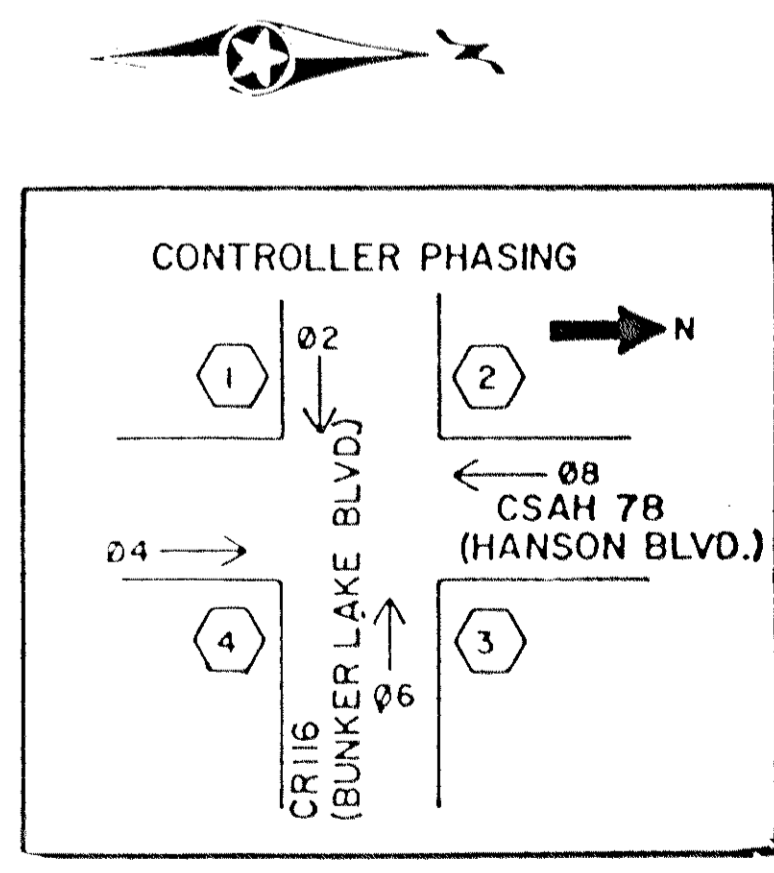

NO.	BY	DATE	REVISIONS	ITEM	DESIGN	CHECKED

I hereby certify that this plan was prepared by me or under my direct supervision and that I am a duly Registered Professional Engineer under the laws of the state of Minnesota.
Date: 3/16/98 Reg. No. 22457



ANOKA COUNTY, MINNESOTA
CITY OF ANDOVER
S.P. 02-678-12
S.P. 02-716-02

TRAFFIC SIGNAL SYSTEM
FOR INFORMATION ONLY
HANSON BOULEVARD NW (CSAH 78) AT
BUNKER LAKE BOULEVARD NW (CSAH 116)

FILE NO. ANOKC9708
DATE 3/16/98
22
59

CONTROLLER AND CABINET

Fed. Project No. _____

CONDUCTOR COLOR CODING

R	BLK	2-1/c#10
O	WH	
BL		
WH		
R/BLK	R	
O/BLK	WH	3/c#12
BL/BLK	BLK	
WH/BLK		
BLK	BLK	2/c#14
BLK/WH	CLEAR	
G/BLK		
G		
	R OR O	
	WH OR YEL	3/c#20
	BLK OR BL	

NOTE:
ALL TERMINAL BLOCK CONNECTIONS
SHALL BE ARRANGED AS SPECIFIED ABOVE.

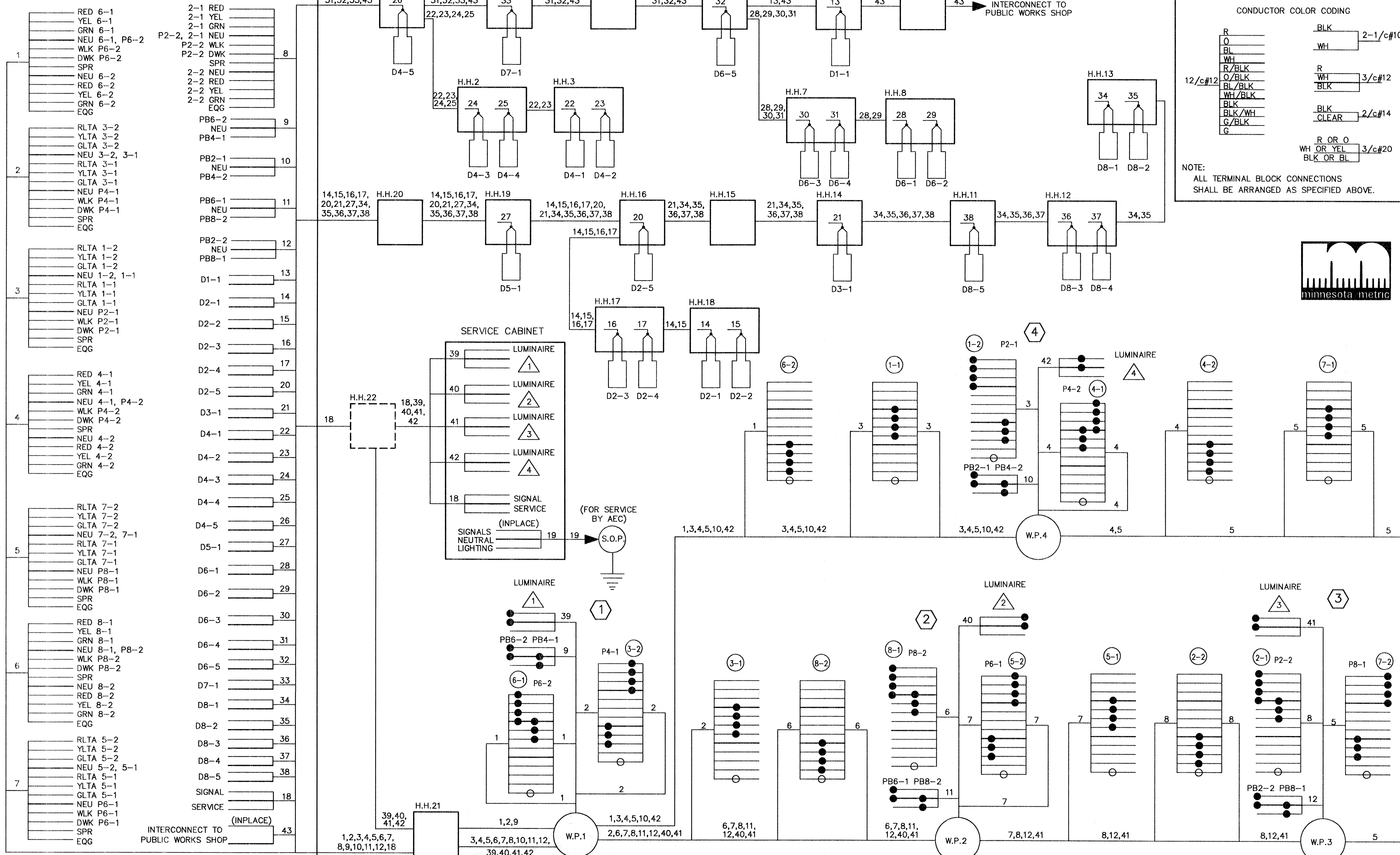
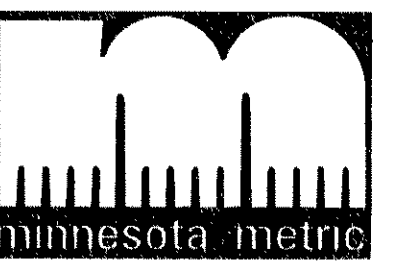

1	JMG	11/9	PER MN/DOT COMMENTS
NO.	BY	DATE	REVISIONS
			ITEM
			DESIGN
			CHECKED

I hereby certify that this plan was prepared by me or under my direct supervision and that I am a duly Registered Professional Engineer under the laws of the state of Minnesota.
 Date: 11/12/98 Reg. No. 22457



ANOKA COUNTY, MINNESOTA
 CITY OF ANDOVER
 S.P. 02-678-12
 S.P. 02-716-02

TRAFFIC SIGNAL SYSTEM
 FIELD WIRING DIAGRAM
 HANSON BOULEVARD NW (CSAH 78) AT
 BUNKER LAKE BOULEVARD NW (CSAH 116)

FILE NO.	21
ANOKC9708	
DATE	3/16/98
	59

CONTROLLER AND CABINET

Fed. Project No.

CONDUCTOR COLOR CODING

R	BLK	2-1/c#10
O	WH	
BL	R	3/c#12
WH	WH	
R/BLK	BLK	2/c#14
O/BLK	BLK / WH	
BL/BLK	G/BLK	
WH/BLK		
BLK		
BLK / WH		
G/BLK		
	R OR O	3/c#20
	WH OR YEL	
	BLK OR BL	

NOTE: ALL TERMINAL BLOCK CONNECTIONS SHALL BE ARRANGED AS SPECIFIED ABOVE.

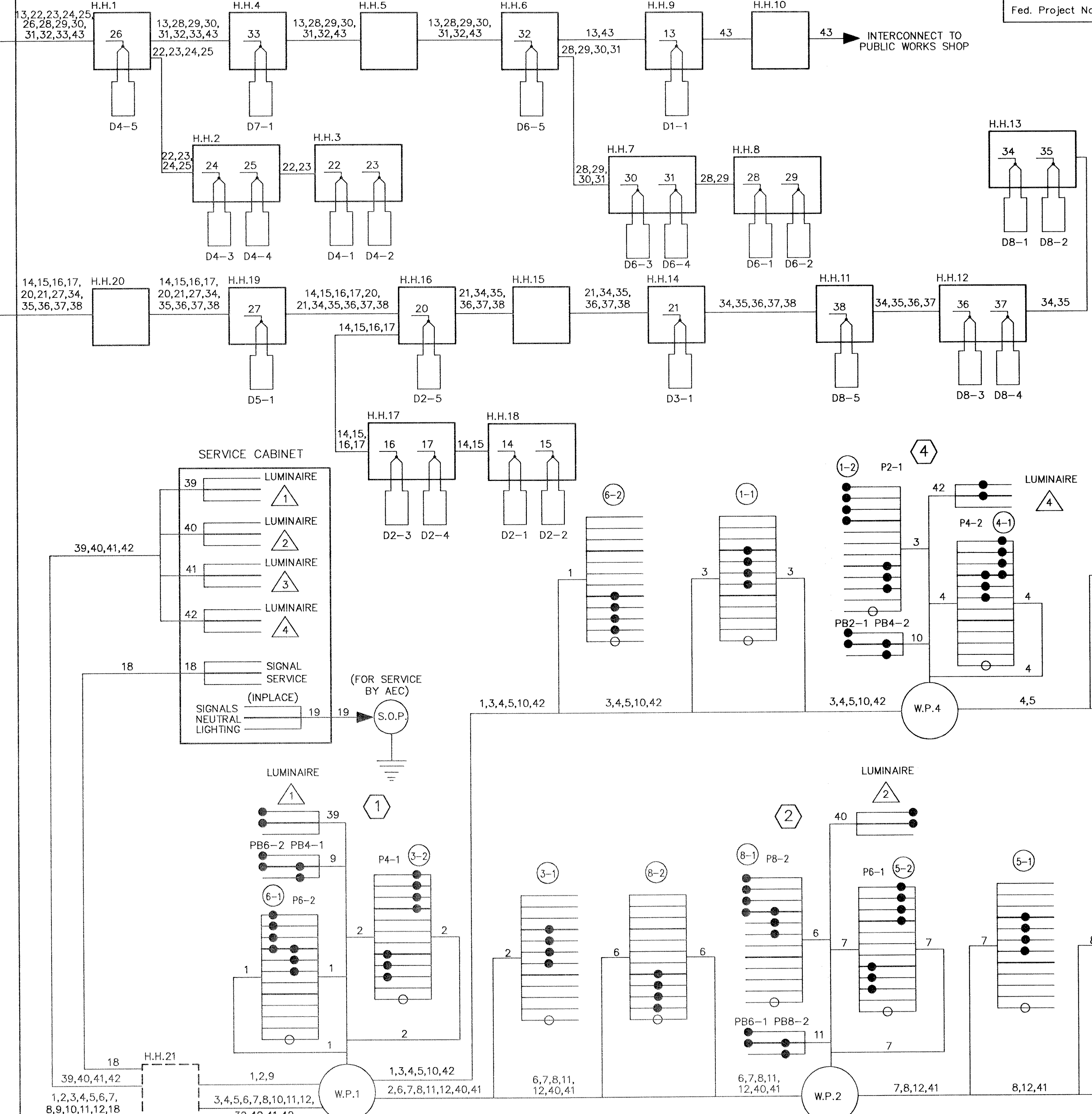
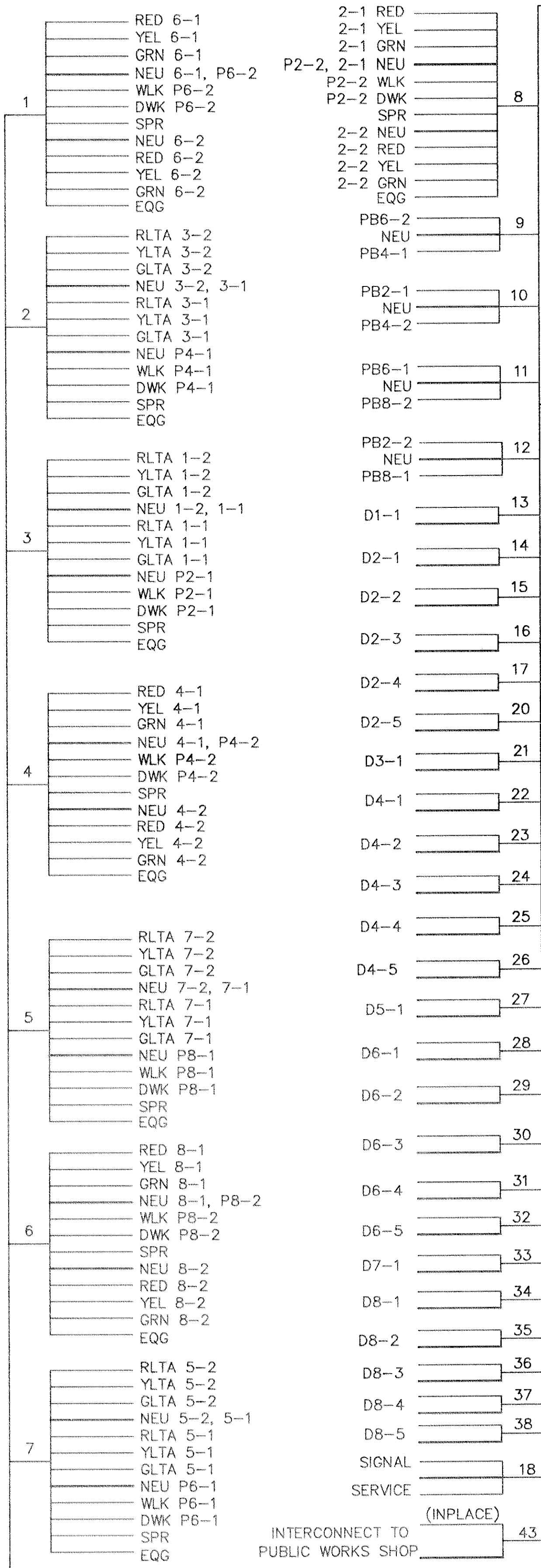

SERVICE CABINET

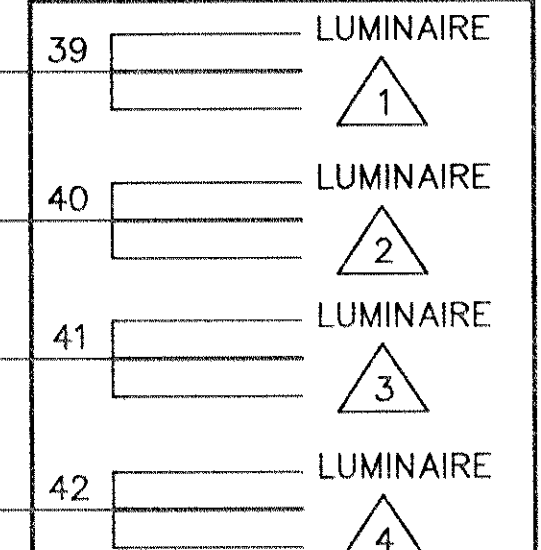

(FOR SERVICE BY AEC)

S.O.P.

(INPLACE)

SIGNALS NEUTRAL LIGHTING

1

2

3

4

1

2

1

2

1

2

1

2

1

2

1

2

1

2

1

2

1

2

1

2

1

2

1

2

1

2

1

2

1

2

1

2

1

2

1

2

1

2

1

2

1

2

1

2

1

2

1

2

1

2

1

2

1

2

1

2

1

2

1

2

1

2

1

2

1

2

1

2

1

2

1

2

1

2

1

2

1

2

1

2

1

2

1

2

1

2

1

2

1

2

1

2

1

2

1

2

1

2

1

2

1

2

1

2

1

2

1

2

1

2

1

2

1

2

1

2

1

2

1

2

1

2

1

2

1

2

1

2

1

2

1

2

1

2

1

2

1

2

1

2

1

2

1

2

1

2

1

2

1

2

1

2

1

2

1

2

1

2

1

2

1

2

1

2

1

2

1

2

1

2

1

2

1

2

1

2

1

2

1

2

1

2

1

2

1

2

1

2

1

2

1

2

1

2

1

2

1

2

1

2

1

2

1

2

1

2

1

2

1

2

1

2

1

2

1

2

1

2

1

2

1

2

1

2

1

2

1

2

1

2

1

2

1

2

1

2

1

2

1

2

1

2

1

2

1

2

1

2

1

2

1

2

1

2

1

2

1

2

1

2

1

2

1

2

1

2

1

2

1

2

1

2

1

2

1

2

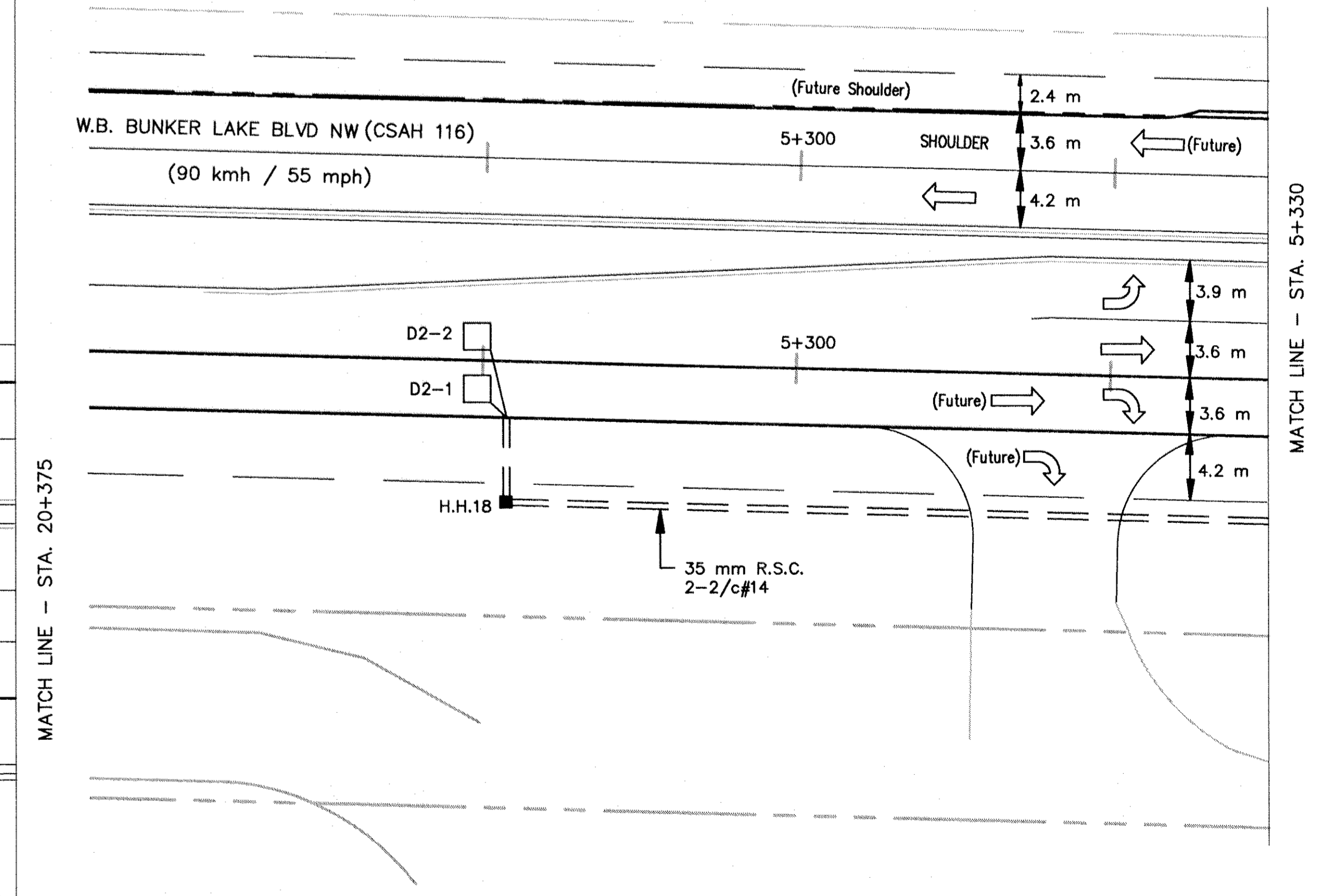
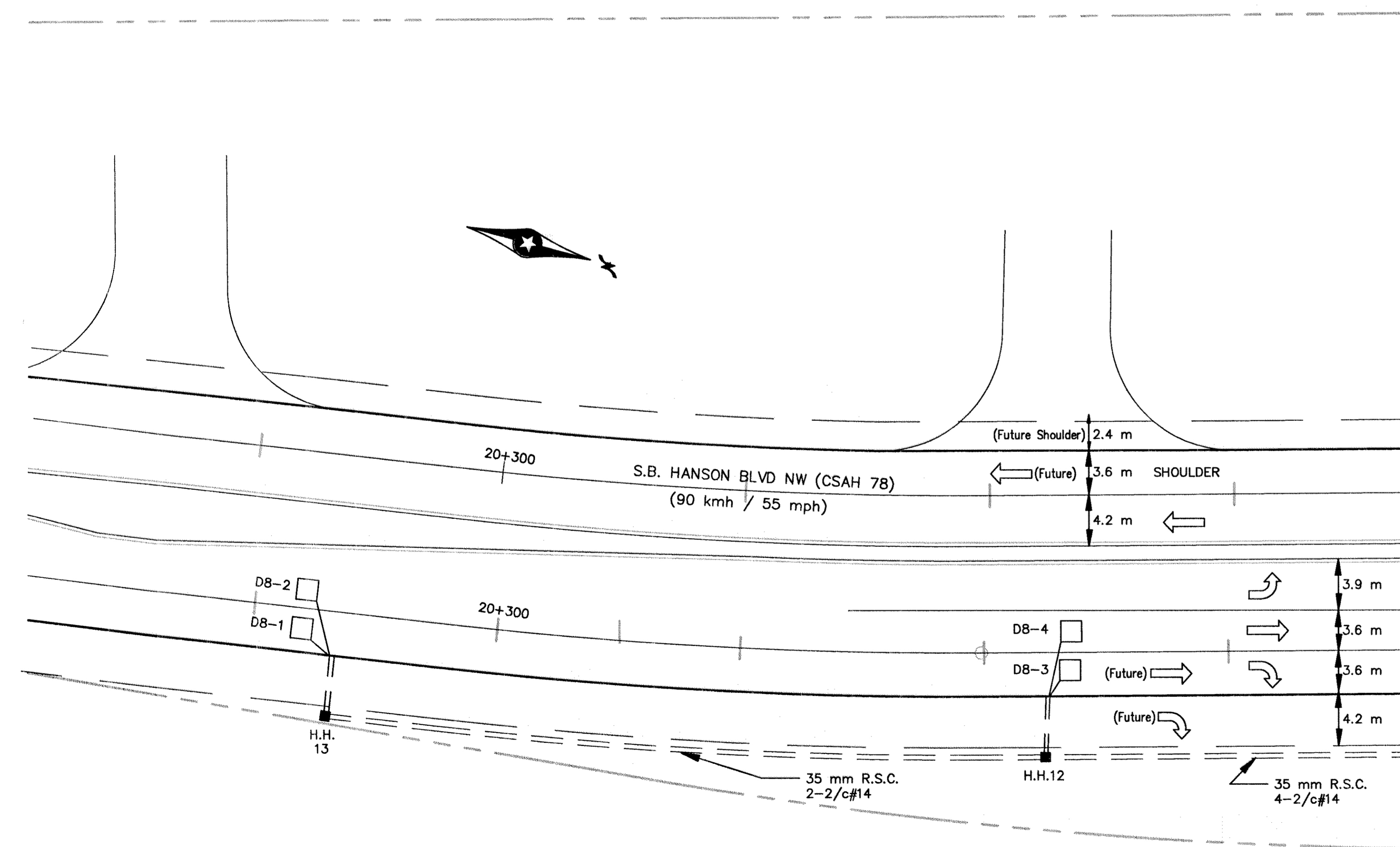
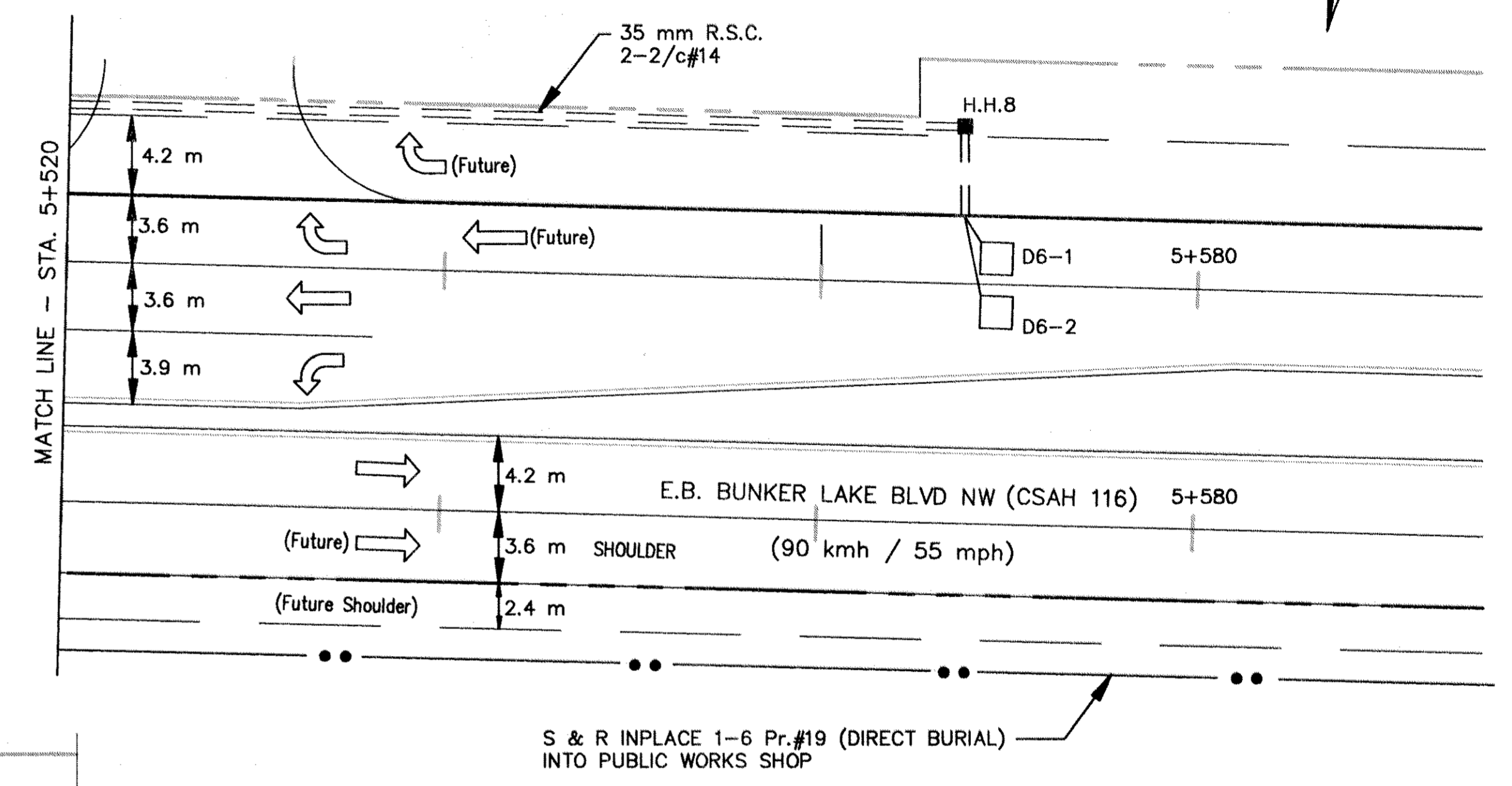
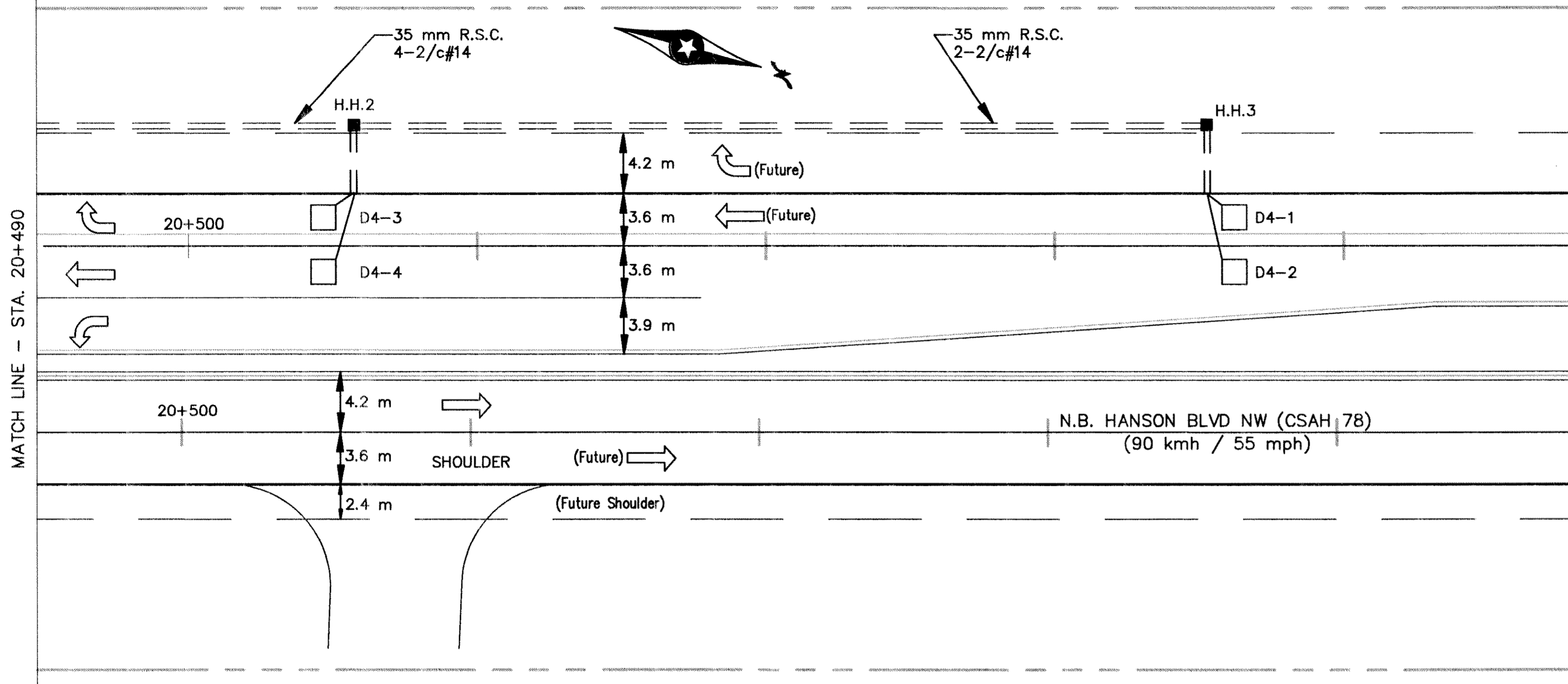
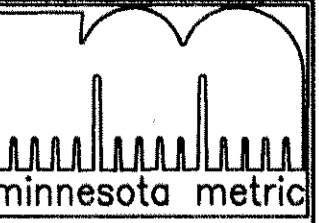
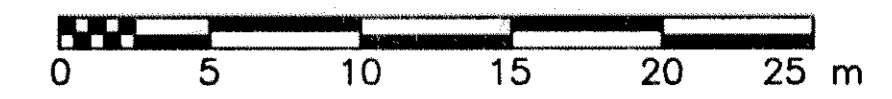

NO.	BY	DATE	REVISIONS	ITEM	DESIGN	CHECKED

I hereby certify that this plan was prepared by me or under my direct supervision and that I am a duly Registered Professional Engineer under the laws of the state of Minnesota.

Date: 11/12/98 Reg. No. 22457



ANOKA COUNTY, MINNESOTA
CITY OF ANDOVER
S.P. 02-678-12
S.P. 02-716-02

TRAFFIC SIGNAL SYSTEM
INTERSECTION LAYOUT
HANSON BOULEVARD NW (CSAH 78) AT
BUNKER LAKE BOULEVARD NW (CSAH 116)

FILE NO. ANOKC9708
DATE 3/16/98
20
59

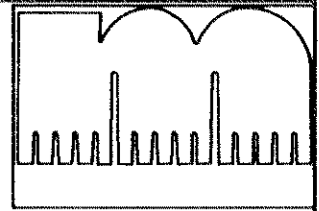
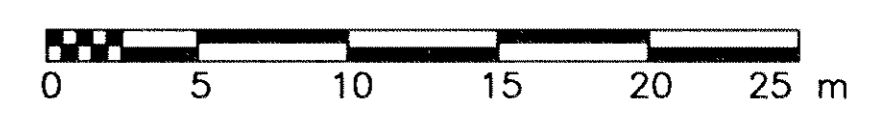

MATCH LINE - STA. 20+490

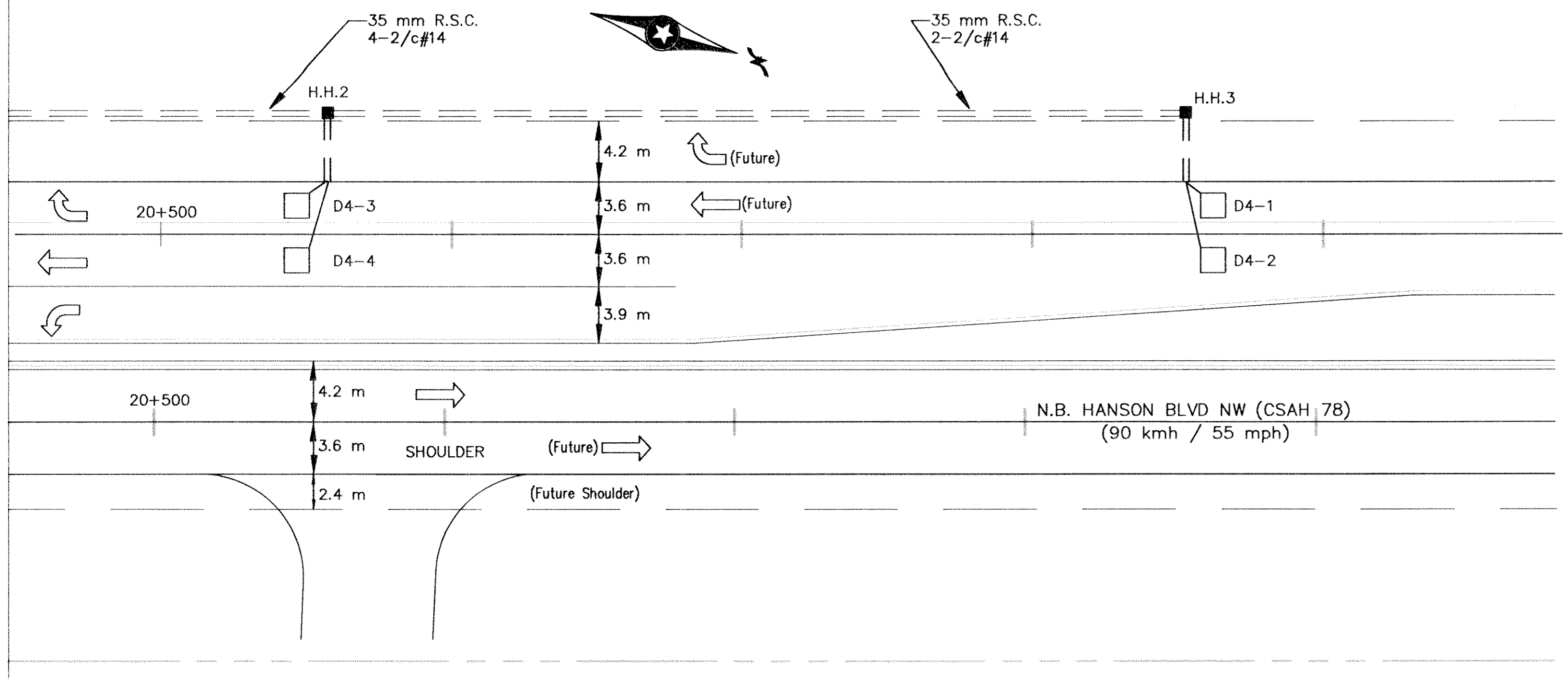

MATCH LINE - STA. 5+520

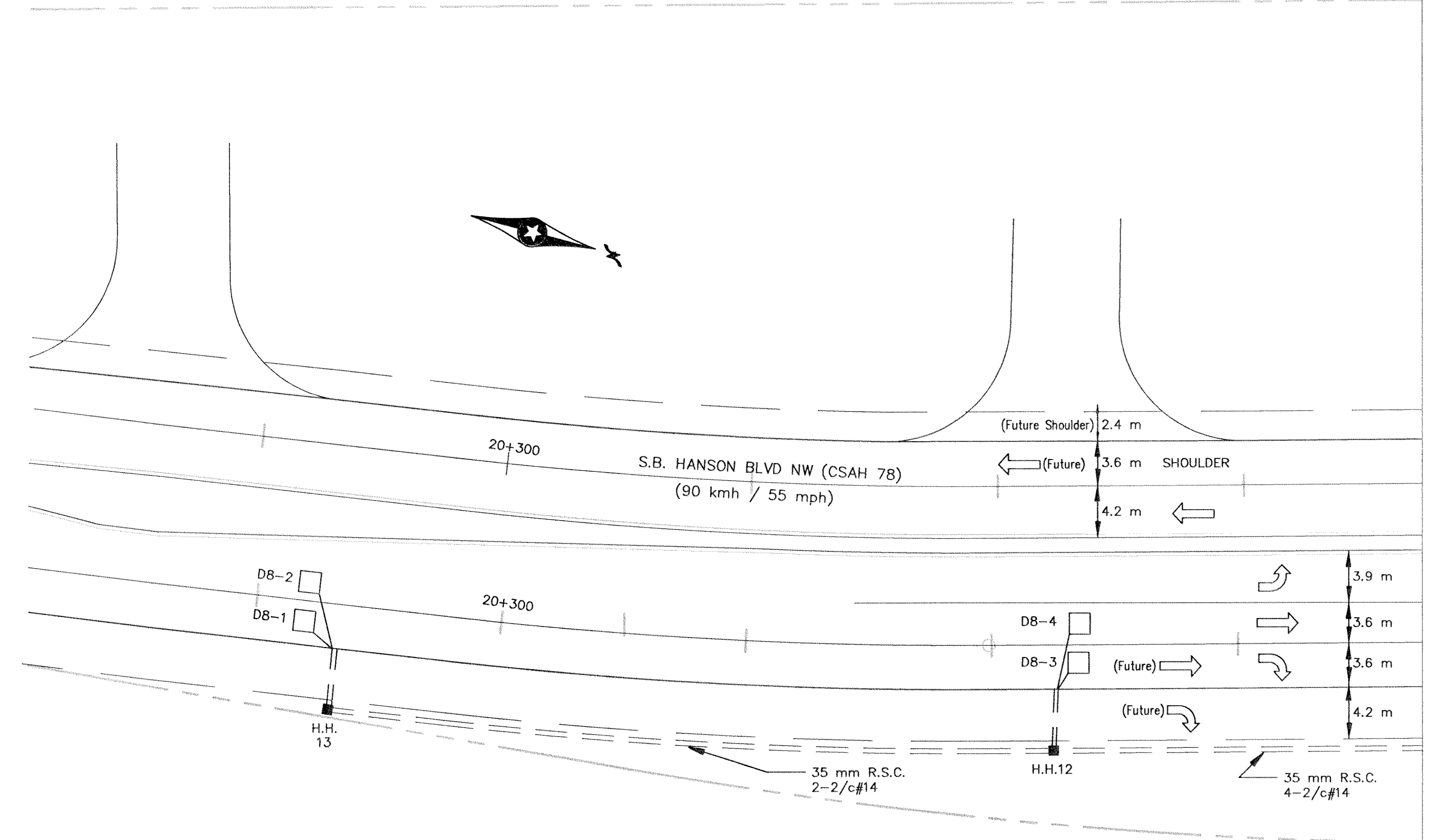
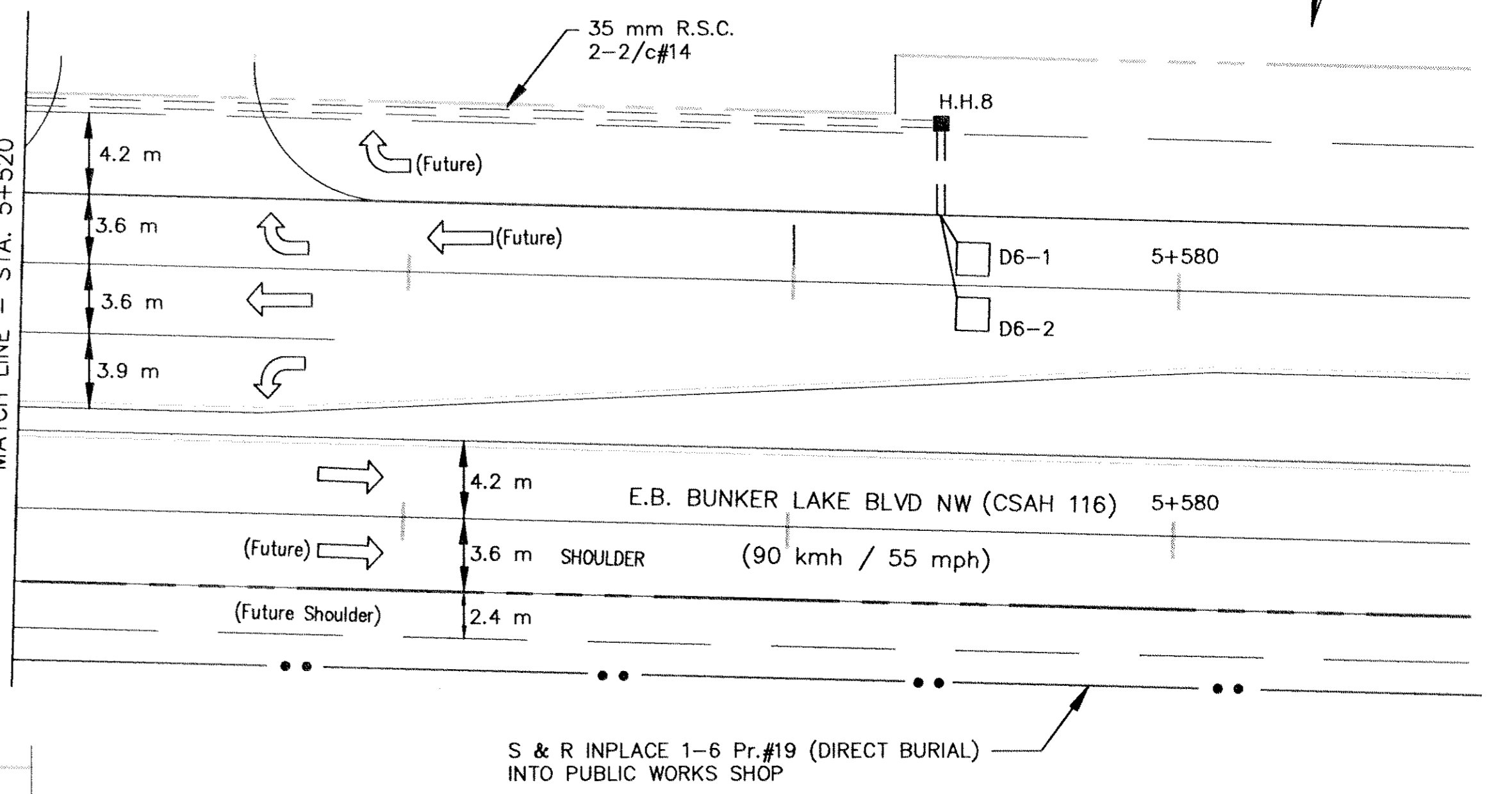

MATCH LINE - STA. 20+375

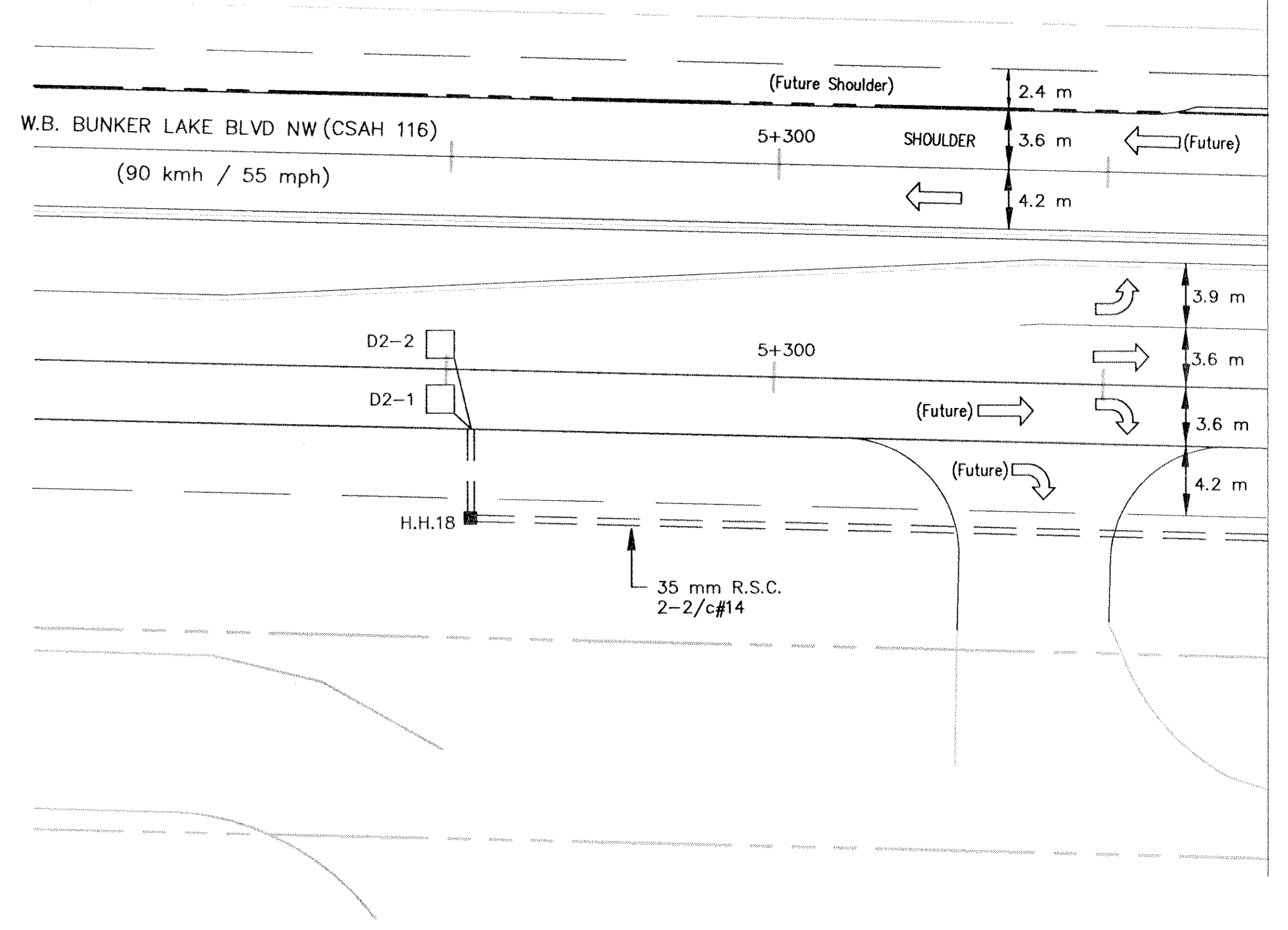

MATCH LINE - STA. 5+330

NO.	BY	DATE	REVISIONS	ITEM	DESIGN	CHECKED

I hereby certify that this plan was prepared by me or under my direct supervision and that I am a duly Registered Professional Engineer under the laws of the state of Minnesota.
 Date: 3/16/98 Reg. No. 22457



ANOKA COUNTY, MINNESOTA
 CITY OF ANDOVER
 S.P. 02-678-12
 S.P. 02-716-02

TRAFFIC SIGNAL SYSTEM
 INTERSECTION LAYOUT
 HANSON BOULEVARD NW (CSAH 78) AT
 BUNKER LAKE BOULEVARD NW (CSAH 116)

FILE NO.
 ANOKC9708
 DATE
 3/16/98
 20
 59

- NOTES:**
- 1) LOCATION OF POLES, FOUNDATIONS, LOOP DETECTORS AND HANDHOLES SHALL BE DETERMINED IN THE FIELD BY THE ENGINEER.
 - 2) ALL LOOP DETECTORS SHALL BE INSTALLED IN NON-METALLIC CONDUIT. SEE DETAILS AND SPECIAL PROVISIONS.
 - 3) NEW HANDHOLES SHALL BE PVC HANDHOLES WITH METAL FRAMES AND COVERS PER Mn/DOT STANDARD PLATE NO. MB114A.
 - 4) SEE SPECIAL PROVISIONS REGARDING REMOVING, SALVAGING AND/OR REINSTALLING INPLACE SIGNAL EQUIPMENT.
 - 5) SEE SPECIAL PROVISIONS REGARDING COUNTY FURNISHED MATERIALS.
 - 6) CONTRACTOR SHALL SALVAGE AND INSTALL INPLACE INTERCONNECT CABLE TO PROVIDE COMMUNICATION BETWEEN SIGNAL SYSTEM AND AN INPLACE COUNTY-OWNED TRAFFIC SIGNAL COMPUTER (LOCATED IN THE COUNTY'S PUBLIC WORKS SHOP).
 - 7) SEE DETAILS FOR WOOD POLE, PEDESTRIAN PUSH BUTTON AND SPAN WIRE MOUNTING DETAILS.
 - 8) CONTRACTOR SHALL FURNISH AND INSTALL NEW LED "RED" AND "RLTA" SIGNAL INDICATIONS FOR ALL COUNTY FURNISHED AND INPLACE VEHICLE SIGNAL FACES.
 - 9) ALL TRAFFIC SIGNAL CABLES AND CONDUCTORS, SPAN WIRE, CONDUIT AND HANDHOLES (EXCEPT AS NOTED) SHALL BE NEW, FURNISHED AND INSTALLED BY CONTRACTOR (REMOVE AND SALVAGE ALL EXISTING CABLES, CONDUCTORS, SPAN WIRE AS DIRECTED IN SPECIAL PROVISIONS).
 - 10) PEDESTRIAN INDICATIONS SHALL BE ONE SECTION HAND/WALKING PERSON INDICATIONS, WITH THE HAND INDICATION BEING LED. SEE SPECIAL PROVISIONS.
 - 11) (R & S) = ITEMS TO BE REMOVED AND SALVAGED BY CONTRACTOR.
(S & R) = ITEMS TO BE SALVAGED AND REINSTALLED BY CONTRACTOR.
(F & I) = ITEMS TO BE FURNISHED AND INSTALLED BY CONTRACTOR.

LOOP DETECTORS (N.M.C.)				
NUMBER	SIZE (m)	LOCATION	FUNCTION	
D1-1	2-1.7x1.7	3 m x 12 m	1	
D2-1	1.7x1.7	125 m	3	
D2-2	1.7x1.7	125 m	3	
D2-3	1.7x1.7	62 m	4	
D2-4	1.7x1.7	62 m	4	
D2-5	2-1.7x1.7	1.5 m	2	
D3-1	2-1.7x1.7	3 m x 12 m	1	
D4-1	1.7x1.7	125 m	3	
D4-2	1.7x1.7	125 m	3	
D4-3	1.7x1.7	62 m	4	
D4-4	1.7x1.7	62 m	4	
D4-5	2-1.7x1.7	1.5 m	2	
D5-1	2-1.7x1.7	3 m x 12 m	1	
D6-1	1.7x1.7	125 m	3	
D6-2	1.7x1.7	125 m	3	
D6-3	1.7x1.7	62 m	4	
D6-4	1.7x1.7	62 m	4	
D6-5	2-1.7x1.7	1.5 m	2	
D7-1	2-1.7x1.7	3 m x 12 m	1	
D8-1	1.7x1.7	125 m	3	
D8-2	1.7x1.7	125 m	3	
D8-3	1.7x1.7	62 m	4	
D8-4	1.7x1.7	62 m	4	
D8-5	2-1.7x1.7	1.5 m	2	

- FUNCTIONS:**
- 1) CALL AND EXTEND
 - 2) CALL ONLY
 - 3) EXTEND ONLY
 - 4) CALL ONLY DENSITY

NOTE: LOCATION=DISTANCE FROM STOP BAR TO FRONT OF LOOP DETECTOR.

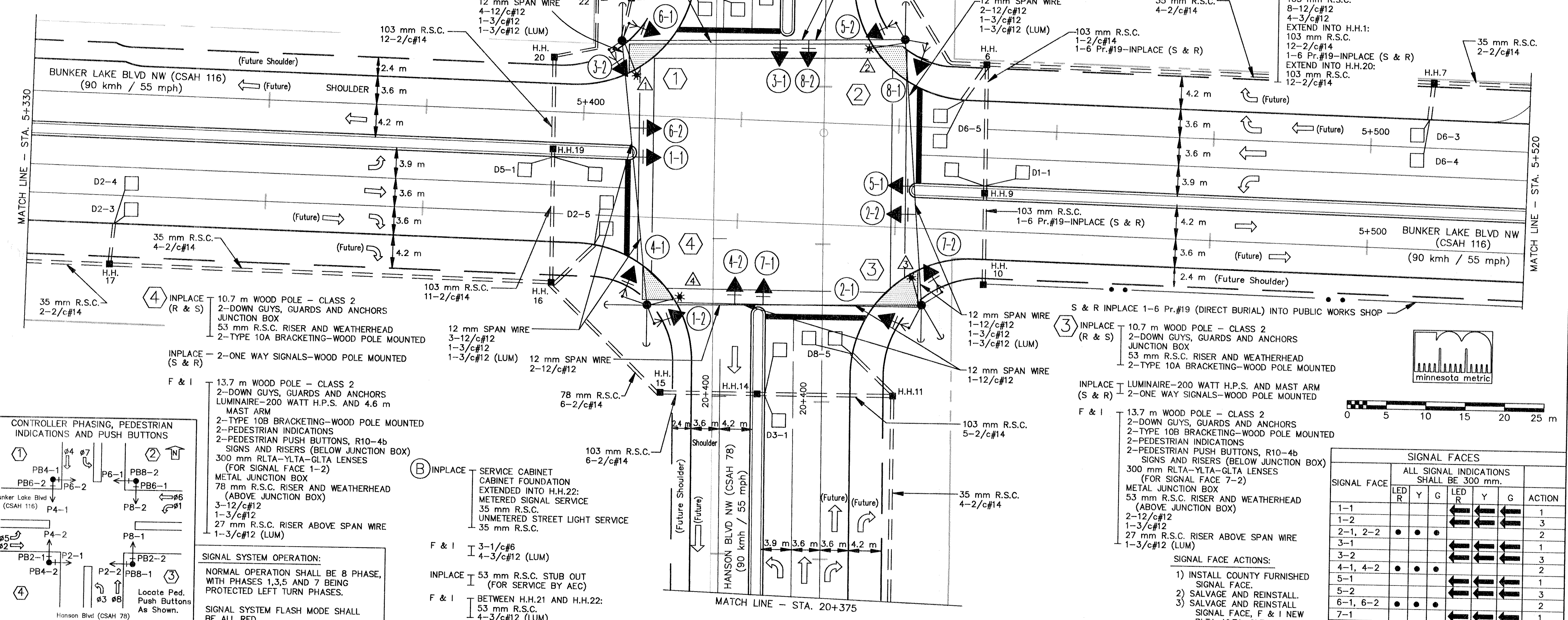

Fed. Project No. _____

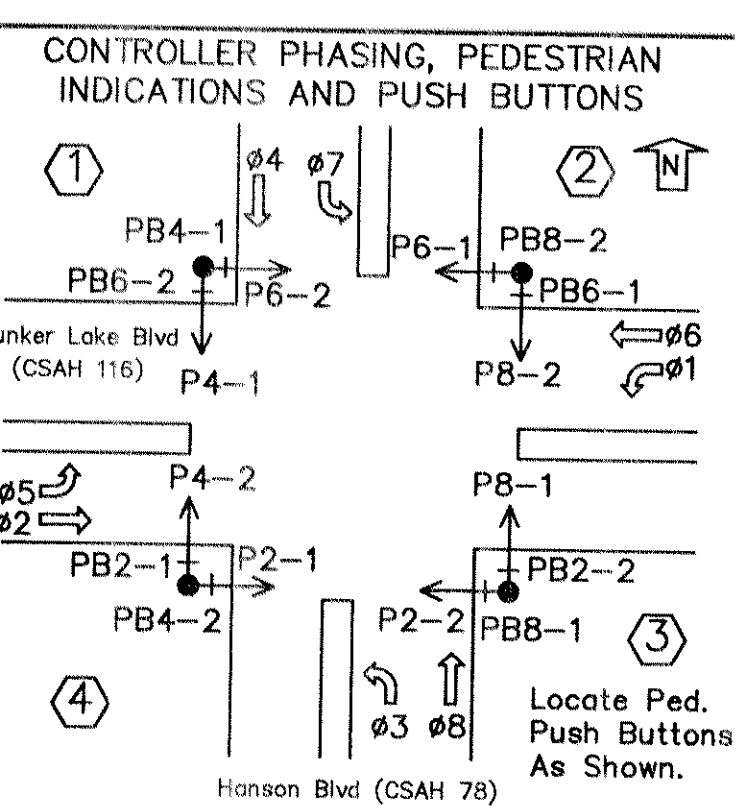
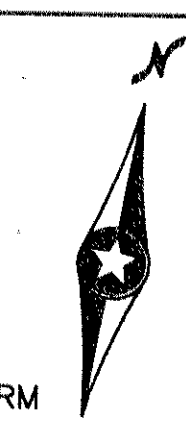

SIGNAL SYSTEM OPERATION:

NORMAL OPERATION SHALL BE 8 PHASE, WITH PHASES 1,3,5 AND 7 BEING PROTECTED LEFT TURN PHASES.

SIGNAL SYSTEM FLASH MODE SHALL BE ALL RED.

(B) INPLACE SERVICE CABINET
CABINET FOUNDATION
EXTENDED INTO H.H.22:
METERED SIGNAL SERVICE
35 mm R.S.C.
UNMETERED STREET LIGHT SERVICE
35 mm R.S.C.

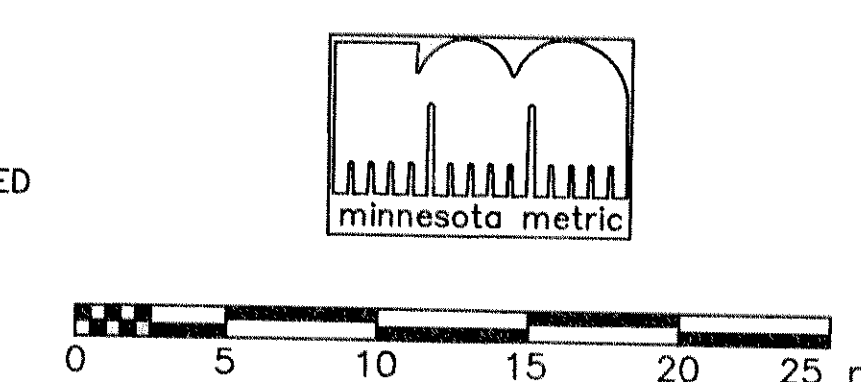

SIGNAL FACES							
ALL SIGNAL INDICATIONS SHALL BE 300 mm.							
SIGNAL FACE	LED R	Y	G	LED R	Y	G	ACTION
1-1				←	←	←	1
1-2				←	←	←	3
2-1, 2-2	•	•	•				2
3-1				←	←	←	1
3-2				←	←	←	3
4-1, 4-2	•	•	•				2
5-1				←	←	←	1
5-2				←	←	←	3
6-1, 6-2	•	•	•				2
7-1				←	←	←	1
7-2				←	←	←	3
8-1, 8-2	•	•	•				2

- SIGNAL FACE ACTIONS:**
- 1) INSTALL COUNTY FURNISHED SIGNAL FACE.
 - 2) SALVAGE AND REINSTALL.
 - 3) SALVAGE AND REINSTALL SIGNAL FACE, F & I NEW RLTA-YLTA-GLTA LENSES.

DATE	REVISIONS	ITEM	DESIGN	CHECKED
JMG 11/9				

I hereby certify that this plan was prepared by me or under my direct supervision and that I am a duly Registered Professional Engineer under the laws of the state of Minnesota.

John M. Jones
Date: 11/12/98 Reg. No. 22457



ANOKA COUNTY, MINNESOTA
CITY OF ANDOVER
S.P. 02-678-12
S.P. 02-716-02

TRAFFIC SIGNAL SYSTEM
INTERSECTION LAYOUT
HANSON BOULEVARD NW (CSAH 78) AT
BUNKER LAKE BOULEVARD NW (CSAH 116)

FILE NO. ANOKC9708
DATE 3/16/98
19
59

- NOTES:**
- 1) LOCATION OF POLES, FOUNDATIONS, LOOP DETECTORS AND HANDHOLES SHALL BE DETERMINED IN THE FIELD BY THE ENGINEER.
 - 2) ALL LOOP DETECTORS SHALL BE INSTALLED IN NON-METALLIC CONDUIT. SEE DETAILS AND SPECIAL PROVISIONS.
 - 3) NEW HANDHOLES SHALL BE PVC HANDHOLES WITH METAL FRAMES AND COVERS PER Mn/DOT STANDARD PLATE NO. M8114A.
 - 4) SEE SPECIAL PROVISIONS REGARDING REMOVING, SALVAGING AND/OR REINSTALLING INPLACE SIGNAL EQUIPMENT.
 - 5) SEE SPECIAL PROVISIONS REGARDING COUNTY FURNISHED MATERIALS.
 - 6) CONTRACTOR SHALL SALVAGE AND INSTALL INPLACE INTERCONNECT CABLE TO PROVIDE COMMUNICATION BETWEEN SIGNAL SYSTEM AND AN INPLACE COUNTY-OWNED TRAFFIC SIGNAL COMPUTER (LOCATED IN THE COUNTY'S PUBLIC WORKS SHOP).
 - 7) SEE DETAILS FOR WOOD POLE, PEDESTRIAN PUSH BUTTON AND SPAN WIRE MOUNTING DETAILS.
 - 8) CONTRACTOR SHALL FURNISH AND INSTALL NEW LED "RED" SIGNAL INDICATIONS FOR ALL COUNTY FURNISHED AND INPLACE VEHICLE SIGNAL FACES.
 - 9) ALL TRAFFIC SIGNAL CABLES AND CONDUCTORS, SPAN WIRE, CONDUIT AND HANDHOLES (EXCEPT AS NOTED) SHALL BE NEW, FURNISHED AND INSTALLED BY CONTRACTOR (REMOVE AND SALVAGE ALL EXISTING CABLES, CONDUCTORS, SPAN WIRE AS DIRECTED IN SPECIAL PROVISIONS).
 - 10) PEDESTRIAN INDICATIONS SHALL BE ONE SECTION HAND/WALKING PERSON INDICATIONS, WITH THE HAND INDICATION BEING LED. SEE SPECIAL PROVISIONS.

LOOP DETECTORS			
NUMBER	SIZE (m)	LOCATION	FUNCTION
D1-1	2-1.7x1.7	3 m x 12 m	1
D2-1	1.7x1.7	125 m	3
D2-2	1.7x1.7	125 m	3
D2-3	1.7x1.7	62 m	4
D2-4	1.7x1.7	62 m	4
D2-5	2-1.7x1.7	1.5 m	2
D3-1	2-1.7x1.7	3 m x 12 m	1
D4-1	1.7x1.7	125 m	3
D4-2	1.7x1.7	125 m	3
D4-3	1.7x1.7	62 m	4
D4-4	1.7x1.7	62 m	4
D4-5	2-1.7x1.7	1.5 m	2
D5-1	2-1.7x1.7	3 m x 12 m	1
D6-1	1.7x1.7	125 m	3
D6-2	1.7x1.7	125 m	3
D6-3	1.7x1.7	62 m	4
D6-4	1.7x1.7	62 m	4
D6-5	2-1.7x1.7	1.5 m	2
D7-1	2-1.7x1.7	3 m x 12 m	1
D8-1	1.7x1.7	125 m	3
D8-2	1.7x1.7	125 m	3
D8-3	1.7x1.7	62 m	4
D8-4	1.7x1.7	62 m	4
D8-5	2-1.7x1.7	1.5 m	2

- FUNCTIONS:**
- 1) CALL AND EXTEND
 - 2) CALL ONLY
 - 3) EXTEND ONLY
 - 4) CALL ONLY DENSITY

NOTE: LOCATION=DISTANCE FROM STOP BAR TO FRONT OF LOOP DETECTOR.

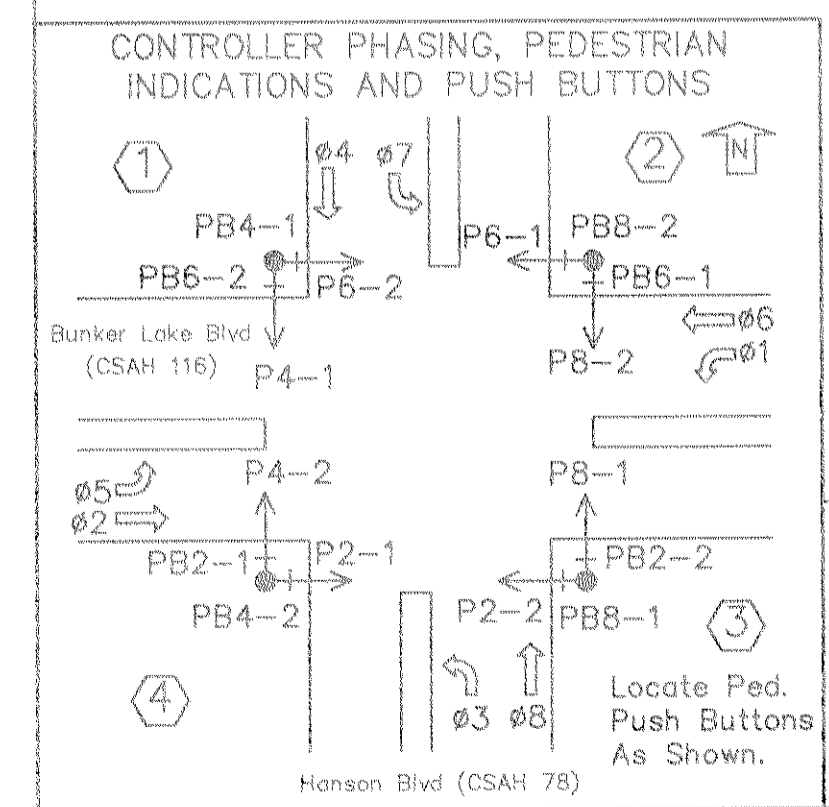
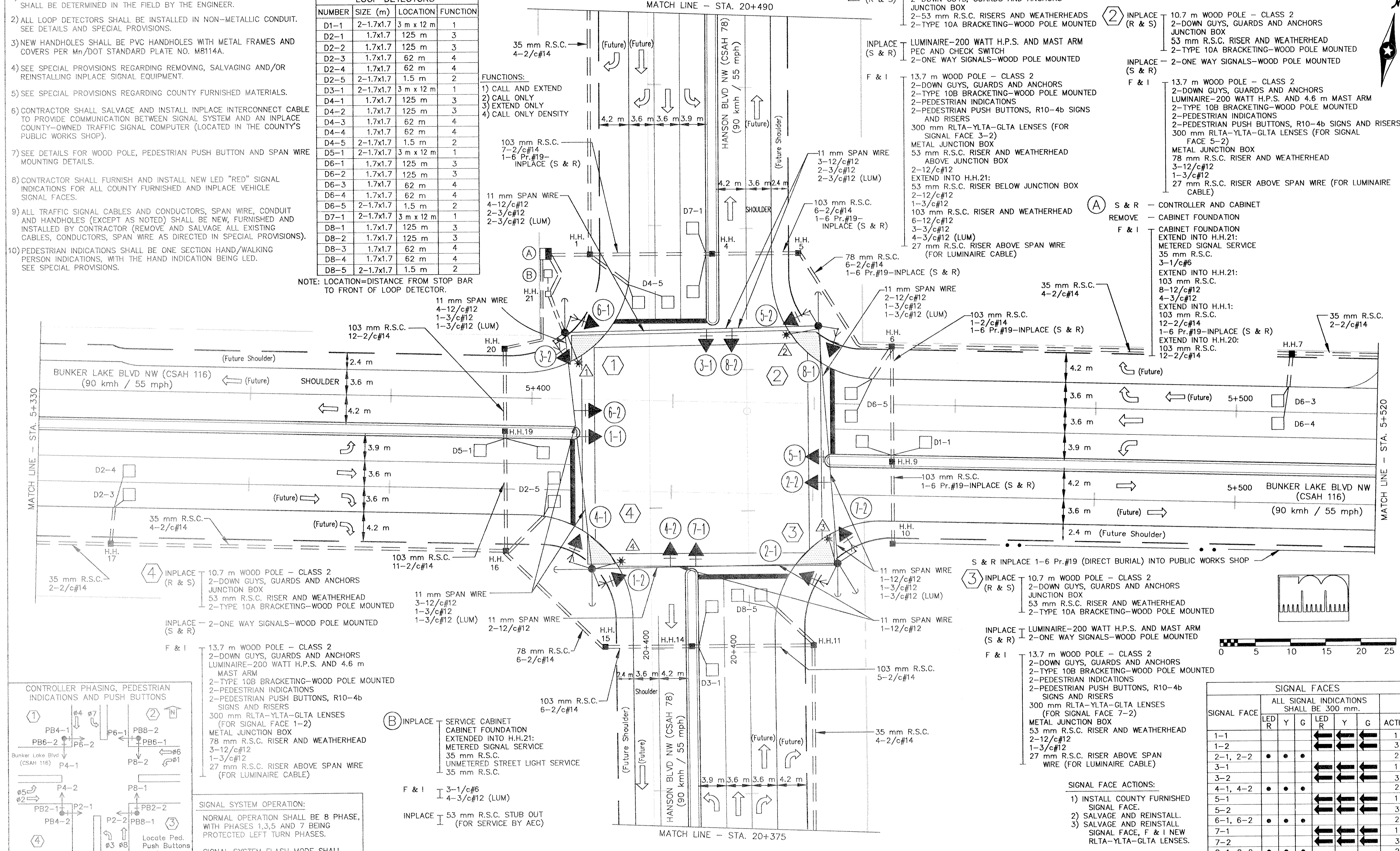

SIGNAL SYSTEM OPERATION:
 NORMAL OPERATION SHALL BE 8 PHASE, WITH PHASES 1,3,5 AND 7 BEING PROTECTED LEFT TURN PHASES.
 SIGNAL SYSTEM FLASH MODE SHALL BE ALL RED.

SIGNAL FACES							
SIGNAL FACE	ALL SIGNAL INDICATIONS SHALL BE 300 mm.						
	LED R	Y	G	LED R	Y	G	ACTION
1-1				←	←	←	1
1-2				←	←	←	3
2-1, 2-2	•	•	•				2
3-1				←	←	←	1
3-2				←	←	←	3
4-1, 4-2	•	•	•				2
5-1				←	←	←	1
5-2				←	←	←	3
6-1, 6-2	•	•	•				2
7-1				←	←	←	1
7-2				←	←	←	3
8-1, 8-2	•	•	•				2

- SIGNAL FACE ACTIONS:**
- 1) INSTALL COUNTY FURNISHED SIGNAL FACE.
 - 2) SALVAGE AND REINSTALL.
 - 3) SALVAGE AND REINSTALL SIGNAL FACE, F & I NEW RLTA-YLTA-GLTA LENSES.

NO.	BY	DATE	REVISIONS	ITEM	DESIGN	CHECKED

I hereby certify that this plan was prepared by me or under my direct supervision and that I am a duly Registered Professional Engineer under the laws of the state of Minnesota.
 Date: 3/16/98 Reg. No. 22457



ANOKA COUNTY, MINNESOTA
 CITY OF ANDOVER
 S.P. 02-678-12
 S.P. 02-716-02

TRAFFIC SIGNAL SYSTEM
 INTERSECTION LAYOUT
 HANSON BOULEVARD NW (CSAH 78) AT
 BUNKER LAKE BOULEVARD NW (CSAH 116)

FILE NO. ANOKC9708
 DATE 3/16/98
 19
 59

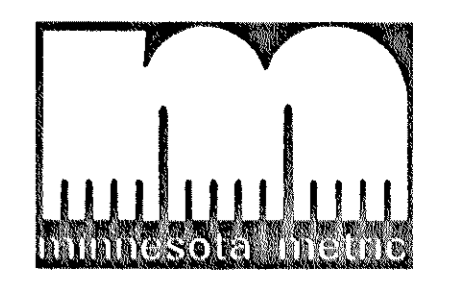

TYPICAL WOOD POLE AND SPAN WIRE MOUNTED TRAFFIC SIGNALS

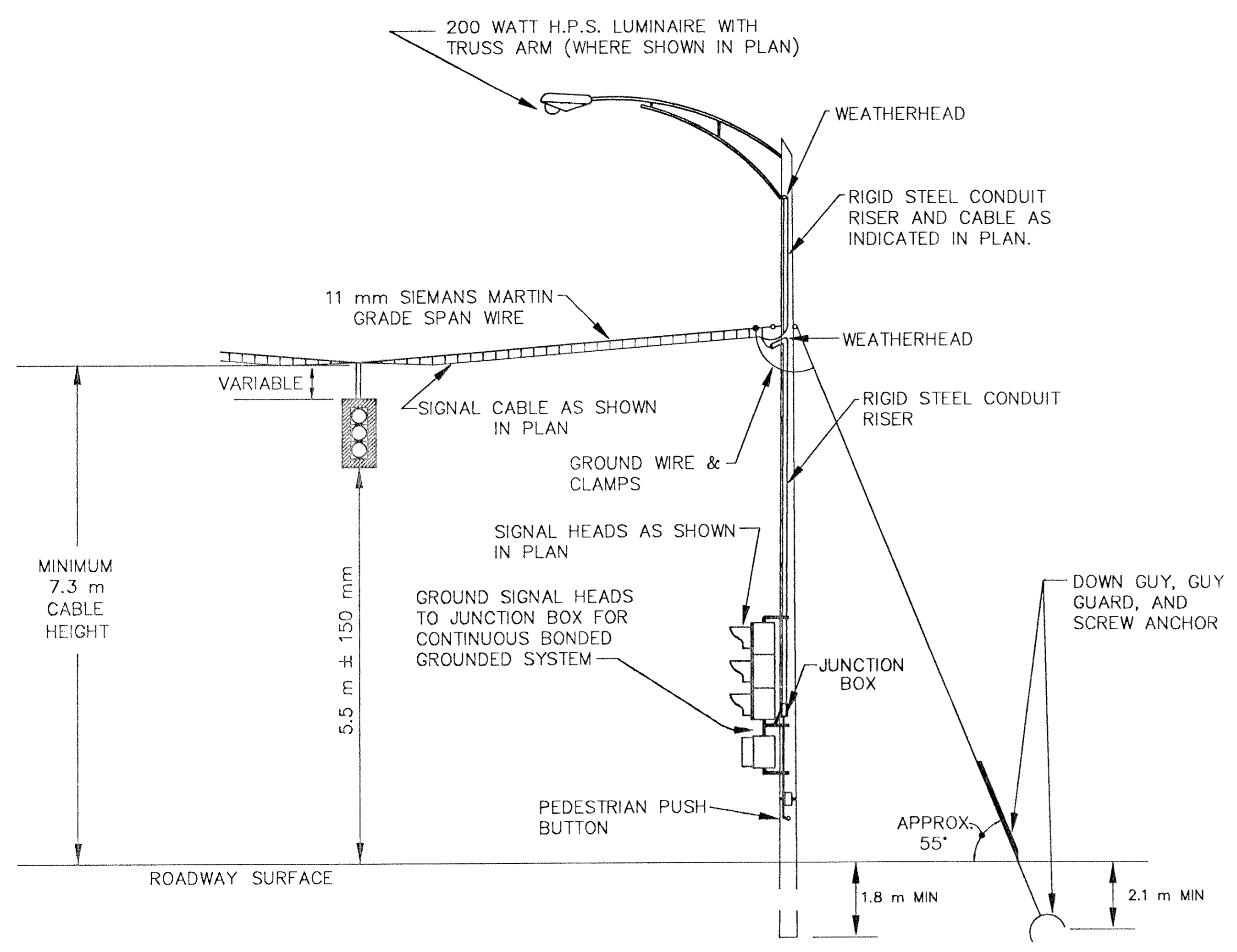

SPAN WIRE MOUNTING DETAIL

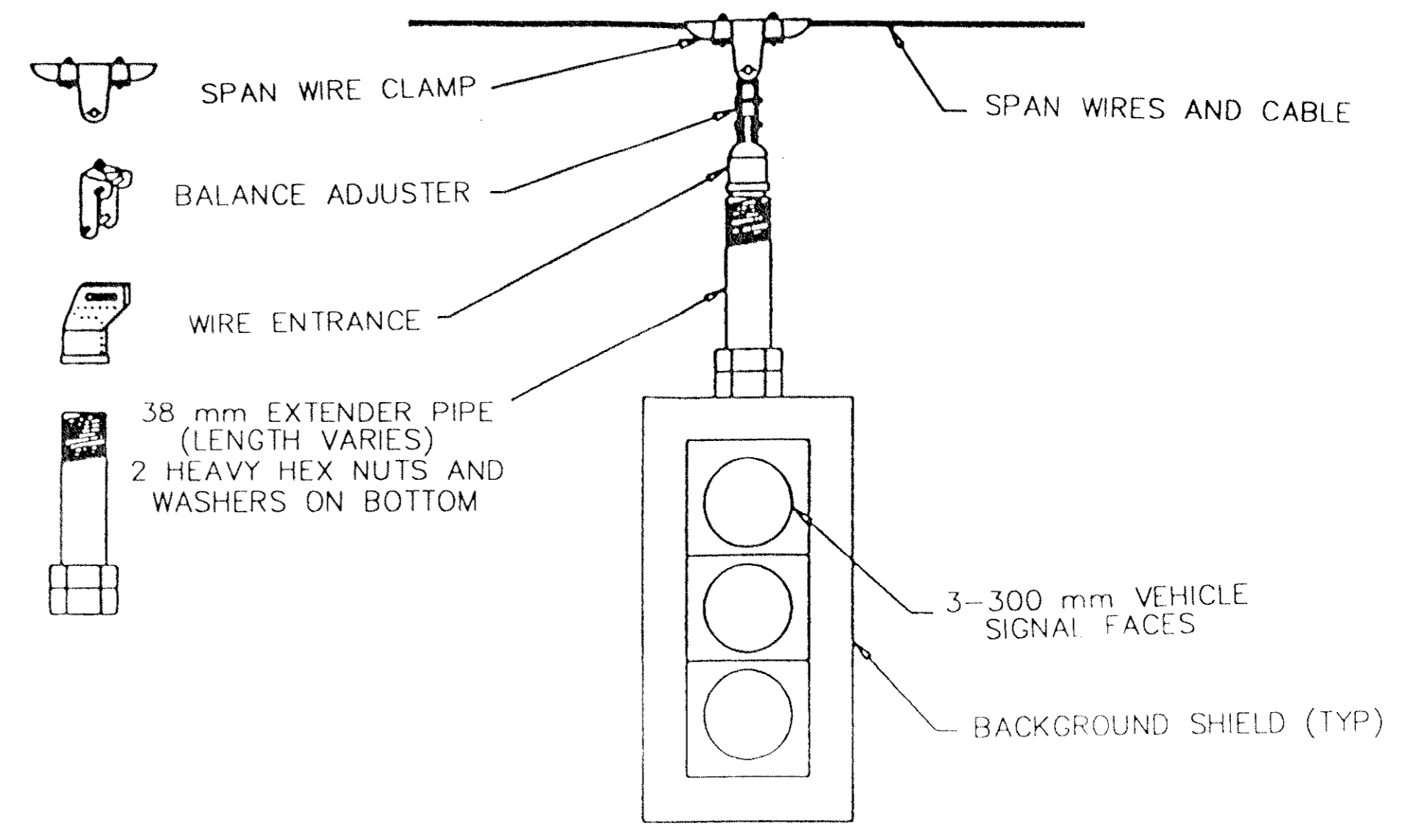

WOOD POLE DETAIL

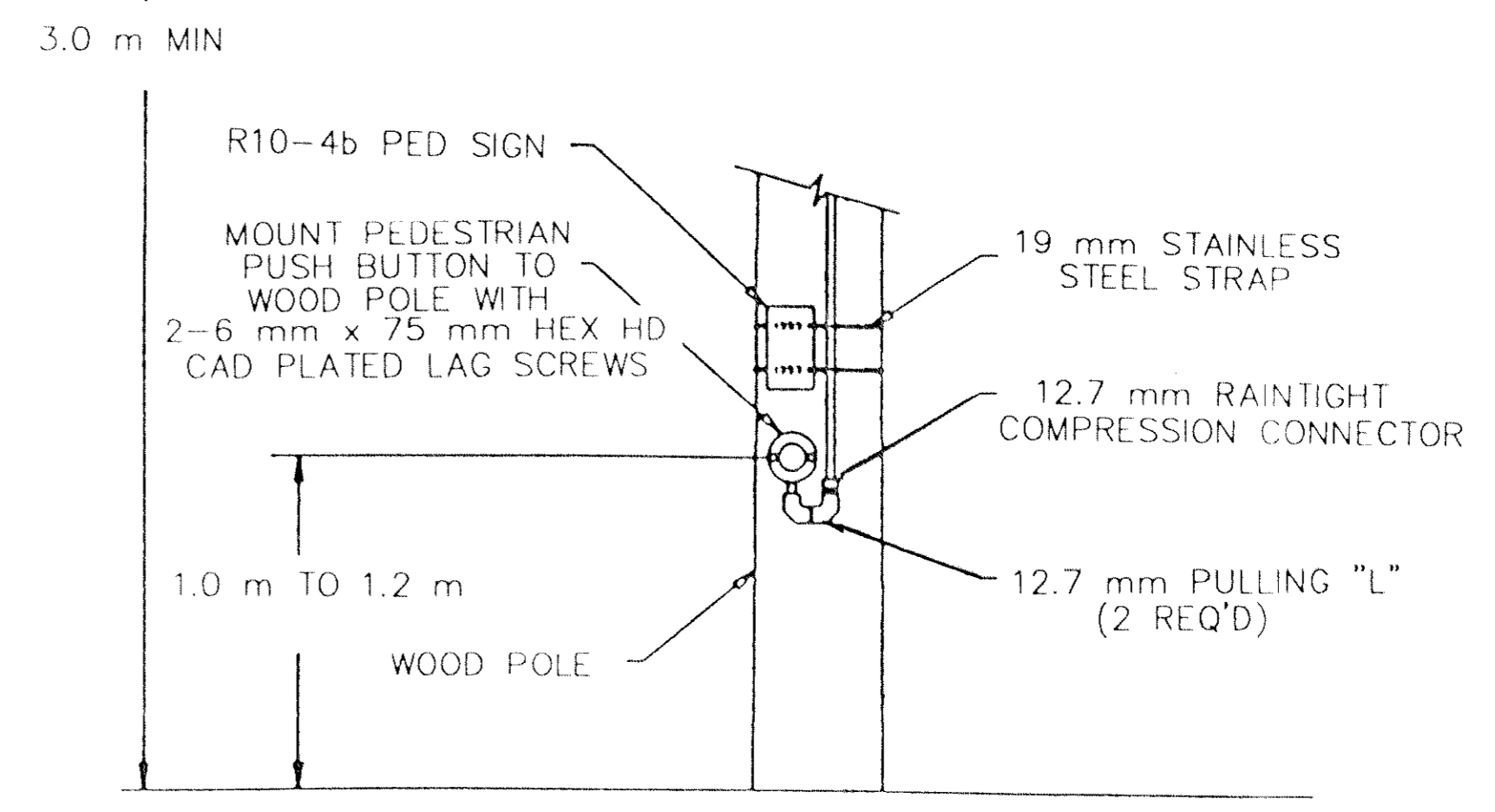
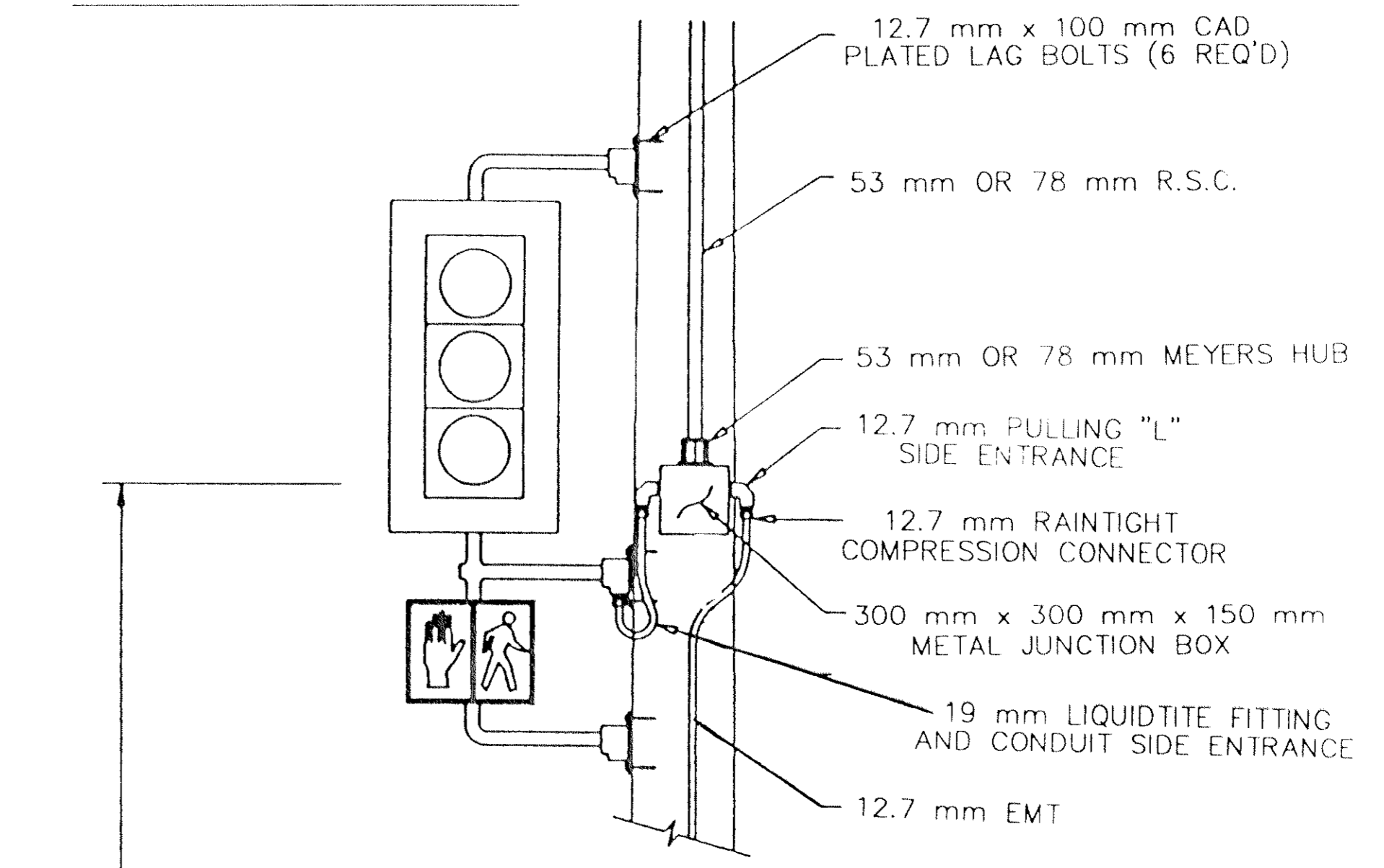

- (A) 35 mm R.S.C. FOR SERVICE CONNECTION
- (B) 103 mm R.S.C. TO HH 21
- (C) 103 mm R.S.C. TO HH 20
- (D) 103 mm R.S.C. TO HH 1
- (E) 15.8 mm DIA X 4.6 m GROUND ROD

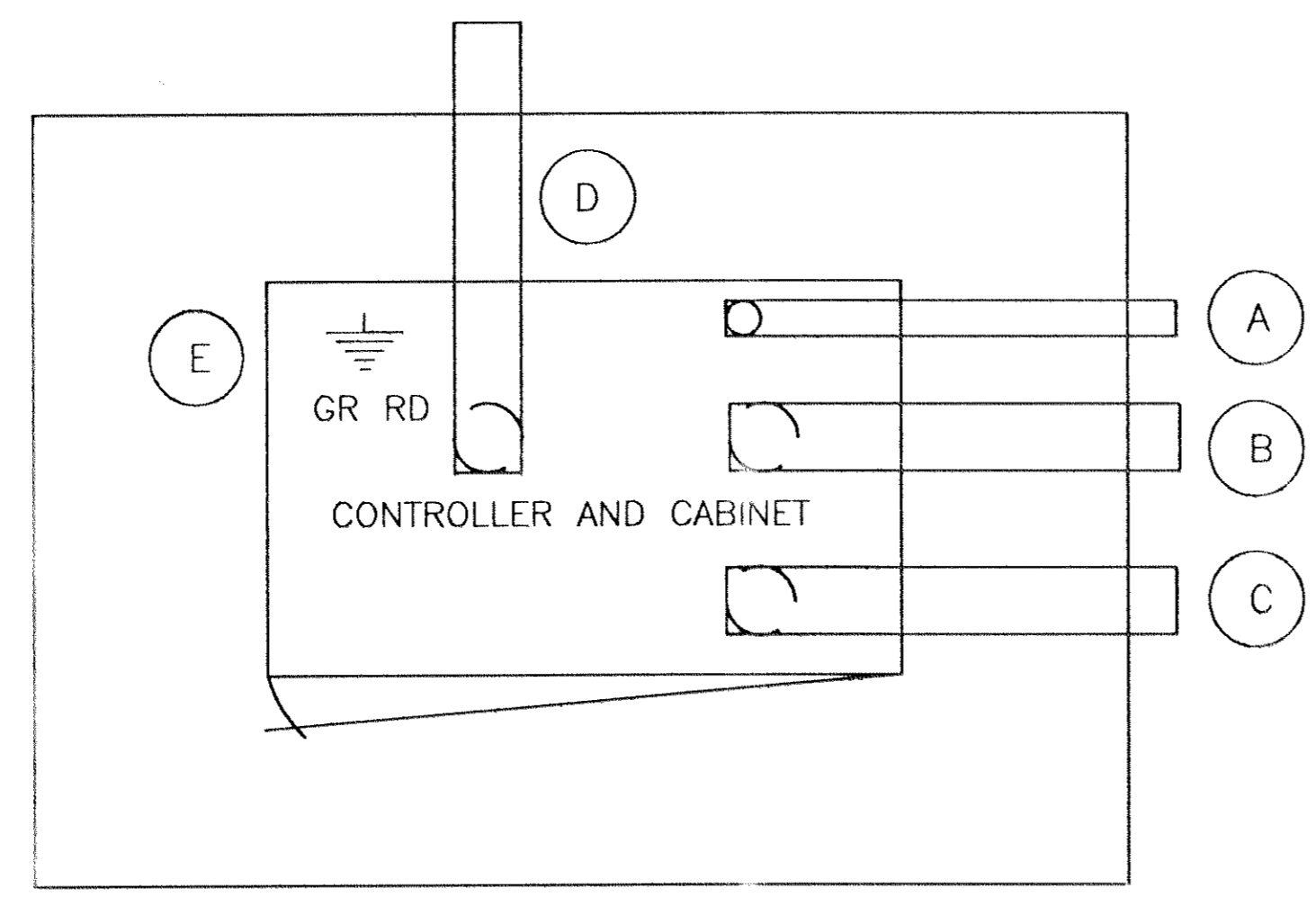

TYPICAL CONTROLLER CABINET PAD LAYOUT
NO SCALE

CONCRETE FOUNDATION
SEE MN/DOT STANDARD PLATE M8119C FOR DIMENSIONS.

SEE INTERSECTION LAYOUT FOR
CONDUIT & CABLE INFORMATION

NO.	BY	DATE	REVISIONS	ITEM	DESIGN	CHECKED

I hereby certify that this plan was prepared by me or under my direct supervision and that I am a duly Registered Professional Engineer under the laws of the state of Minnesota.
Date: 3/16/98 Reg. No. 22457



ANOKA COUNTY, MINNESOTA
CITY OF ANDOVER
S.P. 02-678-12
S.P. 02-716-02

TRAFFIC SIGNAL SYSTEM
TEMPORARY SIGNAL DETAILS
HANSON BOULEVARD NW (CSAH 78) AT
BUNKER LAKE BOULEVARD NW (CSAH 116)

FILE NO. ANOKC9708	18
DATE 3/16/98	59

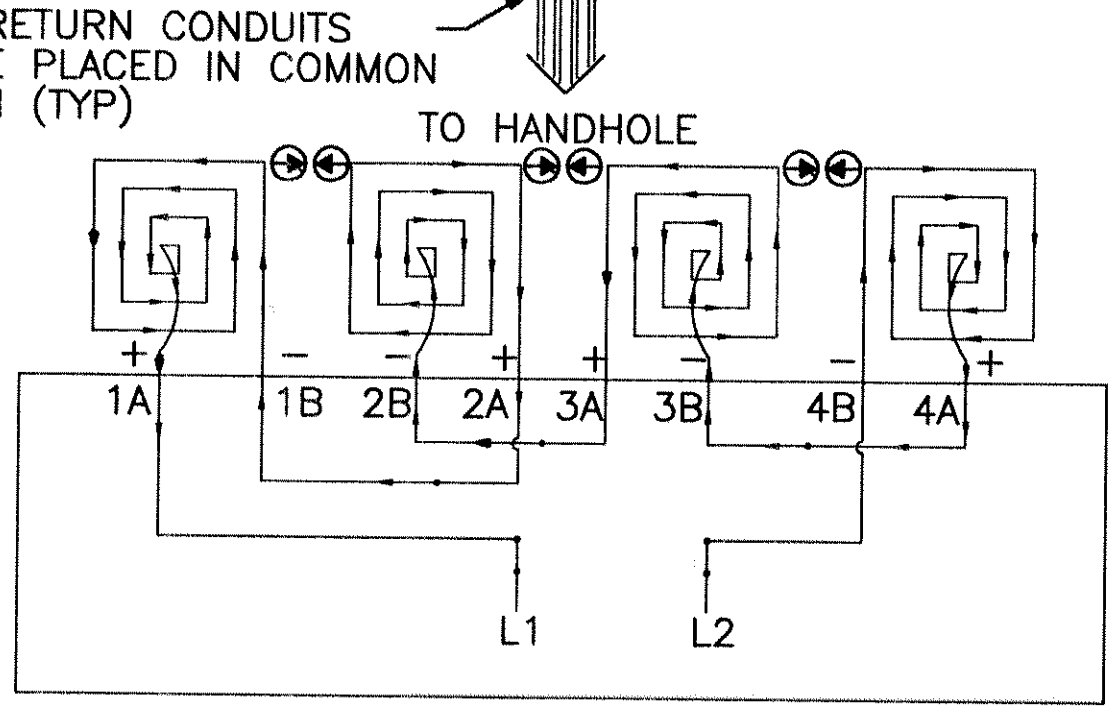
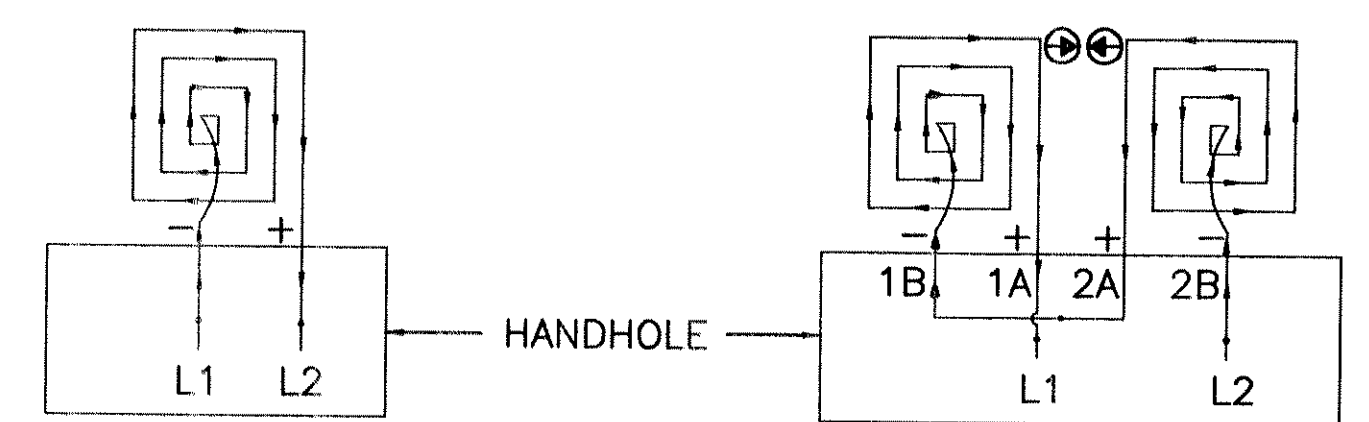
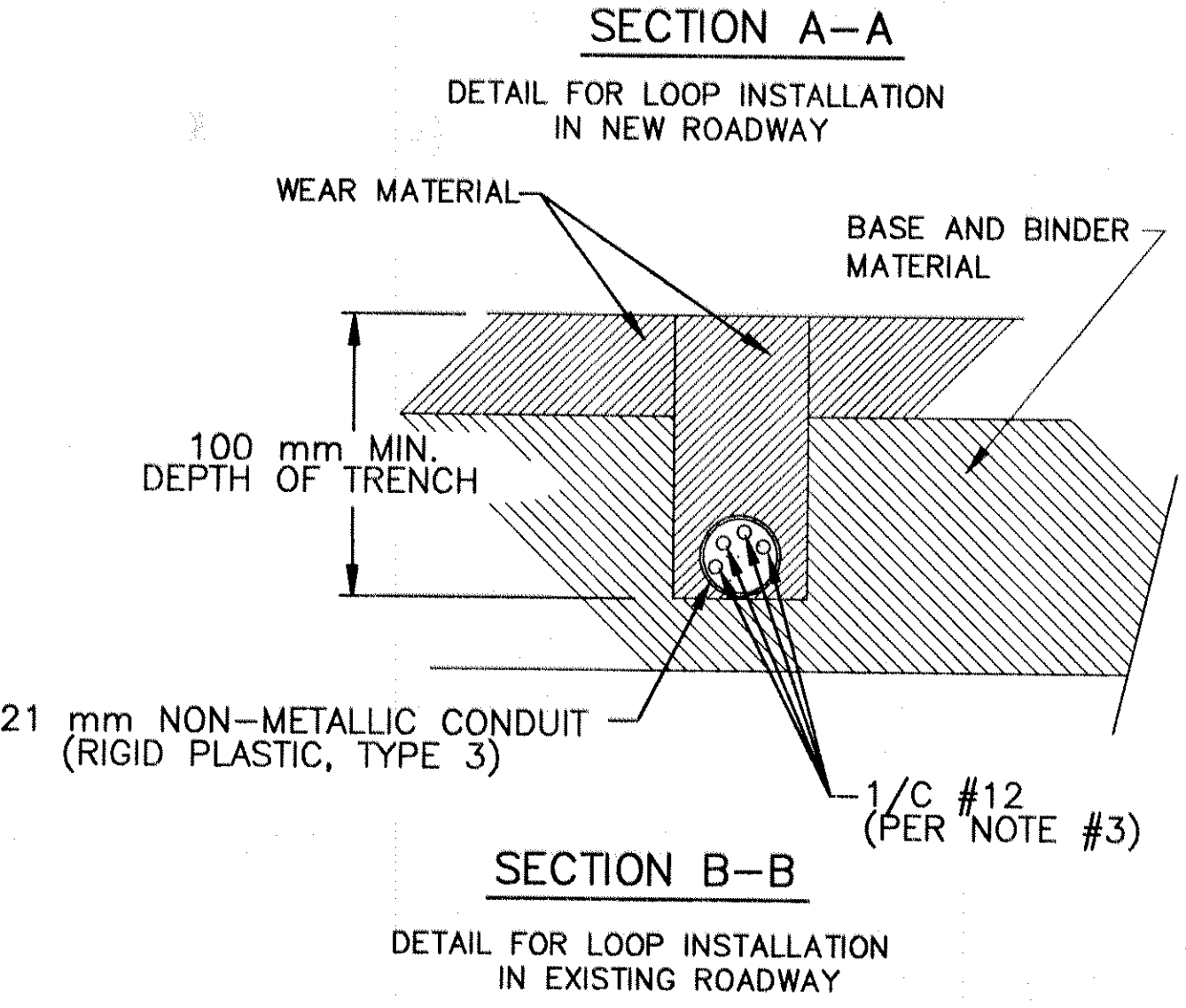
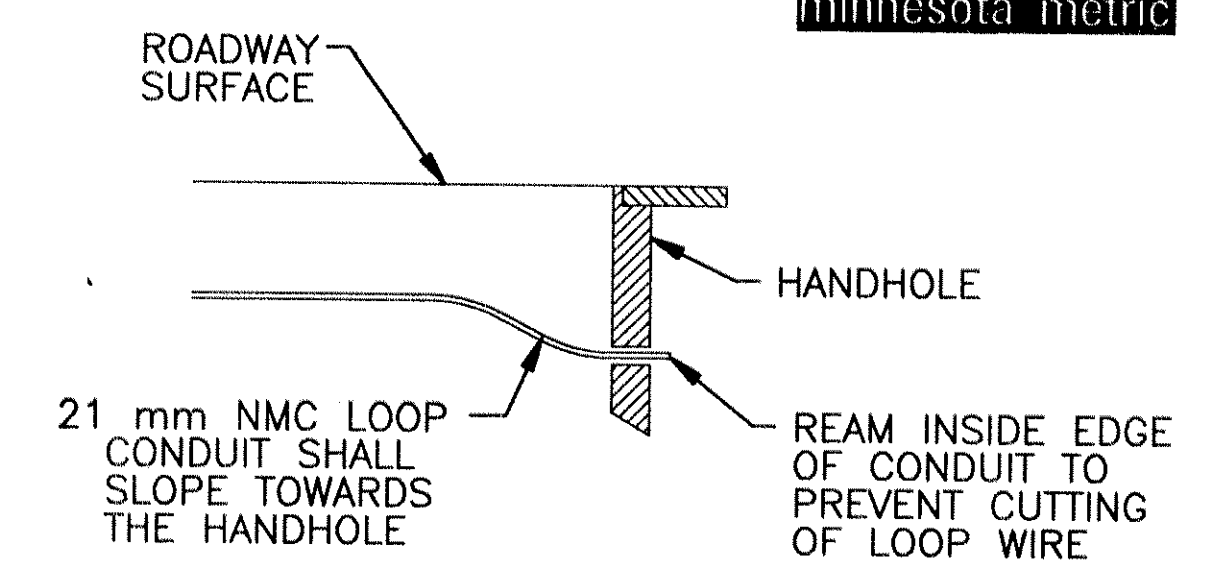
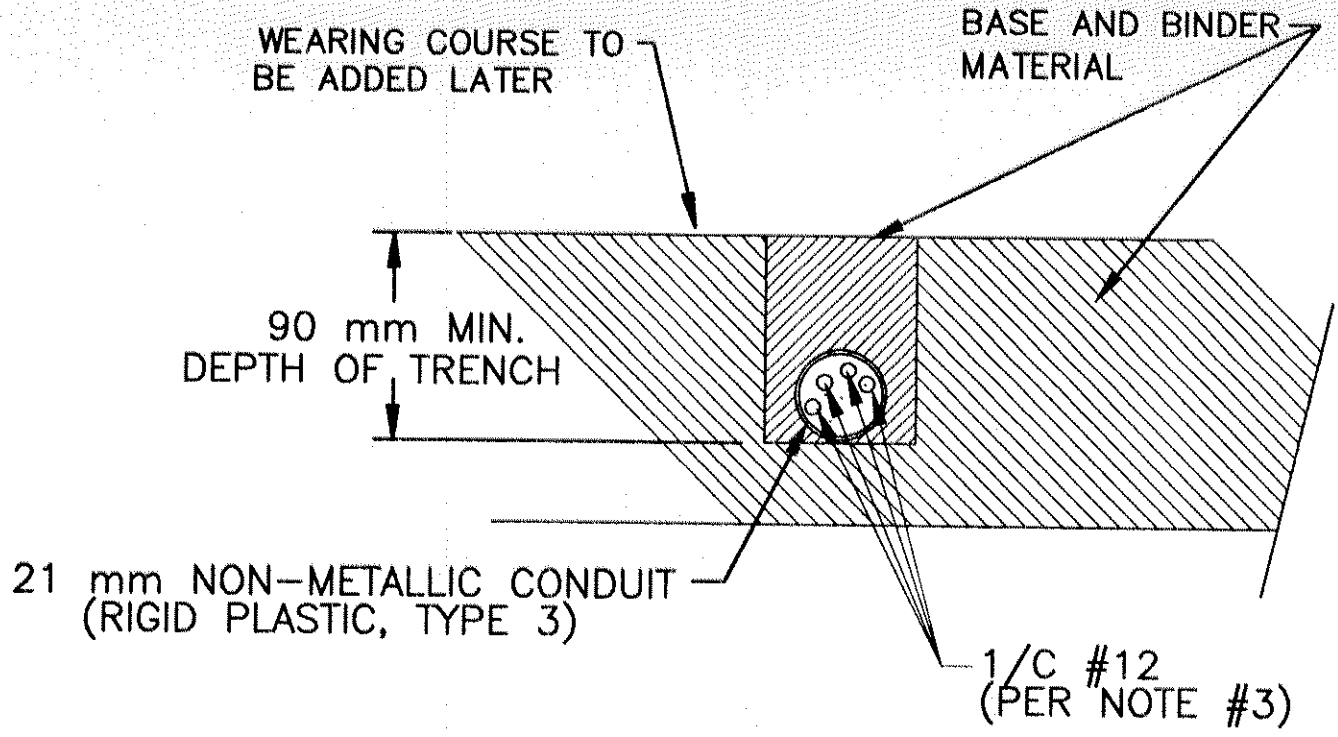
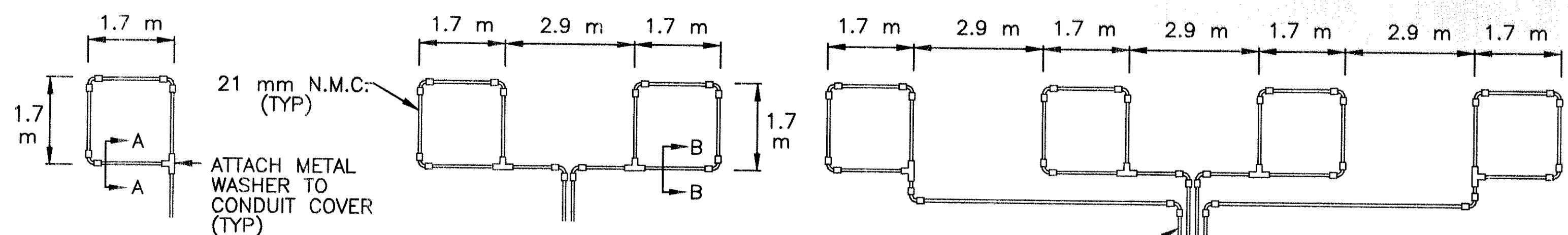
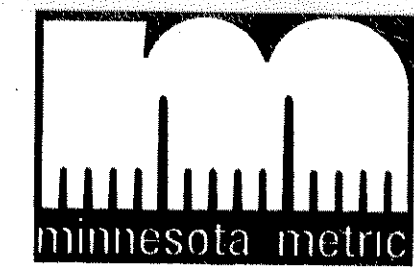

LOOP DETECTOR DETAIL 'A'
(LOOP PHASING FOR SINGLE CONNECTION)

LOOP CONNECTIONS SHALL BE LABELED AND SPLICED IN THE HANDHOLE AS FOLLOWS:

L1 TO 1A
1B TO 2A
2B TO L2

LOOP DETECTOR DETAIL 'B'
(LOOP PHASING FOR SERIES CONNECTION)

LOOP CONNECTIONS SHALL BE LABELED AND SPLICED IN THE HANDHOLE AS FOLLOWS:

L1 TO 1A 3B TO 4A
1B TO 2A 4B TO L2
2B TO 3A

SPLICE CONTROL CABLE TO L1 & L2 IN HANDHOLE. ALL CONDUCTORS SHALL BE TAGGED IN HANDHOLE (1A, 1B, ECT)

LOOP DETECTOR DETAIL 'C'
(LOOP PHASING FOR SERIES CONNECTION)

LOOP DETECTOR WIRING

- 1) ALL CORNERS SHALL BE 90° CONDUIT BENDS.
- 2) CONNECT WIRES IN HANDHOLES USING SPLICE KIT METHOD DESCRIBED IN THE SPECIAL PROVISIONS.
- 3) LOOP DETECTOR WIRES SHALL BE #12 AWG CROSSED LINKED POLYETHYLENE (XLP). SEE SPECIAL PROVISIONS.
- 4) LOOP LEAD IN WIRES SHALL BE TWISTED A MIN. OF (5) TURNS PER 0.3 METER (1 FOOT) THROUGH THE CONDUIT TO THE HANDHOLE.
- 5) NMC DESIGNATES NON-METALLIC CONDUIT (SPEC. 3803)
- 6) LOOPS 1.7 m x 1.7 m THRU 1.7 m x 4.3 m SHALL HAVE (4) TURNS.
- 7) LOOPS 1.7 m x 4.6 m AND LARGER SHALL HAVE (2) TURNS.

LEGEND OF SYMBOLS

CONTROLLER AND SERVICE EQUIP. NO's	(A)
SIGNAL BASE NO.	(1)
SIGNAL FACE NO.	(2)
LUMINAIRE NO.	(3)
CONTROLLER AND CABINET	(4)
CONTROLLER AND CABINET - IN PLACE	(5)
HANDHOLE	(6)
HANDHOLE - IN PLACE	(7)
RIGID STEEL CONDUIT (RSC)	(8)
RIGID STEEL CONDUIT (RSC) - IN PLACE	(9)
SIGNAL FACE WITH BACKGROUND SHIELD	(10)
SIGNAL FACE W/O BACKGROUND SHIELD	(11)
SIGNAL FACE - IN PLACE	(12)
PEDESTRIAN INDICATORS	(13)
PEDESTRIAN INDICATORS - IN PLACE	(14)
PEDESTRIAN PUSH BUTTONS ON PEDESTAL OR POLE	(15)
PEDESTRIAN PUSH BUTTON STATION	(16)
TRAFFIC SIGNAL PEDESTAL	(17)
TRAFFIC SIGNAL PEDESTAL - INPLACE	(18)
TRAFFIC SIGNAL POLE AND MAST ARM	(19)
TRAFFIC SIGNAL POLE AND MAST ARM - IN PLACE	(20)
STREET LIGHT POLE AND LUMINAIRE	(21)
STREET LIGHT POLE AND LUMINAIRE - IN PLACE	(22)
MAST ARM AND LUMINAIRE	(23)
MAST ARM AND LUMINAIRE - INPLACE	(24)
WOOD POLE	(25)
WOOD POLE - IN PLACE	(26)
SOURCE OF POWER	(27)
RAILROAD SIGNAL - IN PLACE	(28)
RIGHT OF WAY LINE	(29)
CENTERLINE	(30)
EDGE OF ROADWAY	(31)
SHOULDERLINE	(32)
CURB LINE	(33)
STOP BAR	(34)

ABBREVIATIONS

3-1(EG)	SIGNAL HEAD PHASE "3" - NO "1"	P2-1(EG)	PEDESTRIAN INDICATION PHASE "2" - NO. "1"
BR. GR.	BARE GROUND	PB	PUSH BUTTON
CH. SW.	CHECK SWITCH	PB2-1(EG)	PUSH BUTTON PHASE "2" - NO. "1"
CLR	CLEAR	PEC	PHOTOELECTRIC CELL
D2-1(EG)	DETECTOR PHASE "2" - NO. "1"	PED	PEDESTRIAN
DWK	DON'T WALK	R	RED
EQG	EQUIPMENT GROUND	R&S	REMOVE AND SALVAGE
EVP	EMERGENCY VEHICLE PRE-EMPTION	RLTA	RED LEFT TURN ARROW
F&I	FURNISH AND INSTALL	RRTA	RED RIGHT TURN ARROW
FL	FLASH/FLASHING	RSC	RIGID STEEL CONDUIT
G	GREEN	S&R	SALVAGE AND REINSTALL
GLTA	GREEN LEFT TURN ARROW	SOP	SOURCE OF POWER
GRN	GREEN	SPR	SPARE
GR. R	GROUND ROD	ST. LHT	STREET LIGHT
GRTA	GREEN RIGHT TURN ARROW	STA	STATION
GTHA	GREEN THRU ARROW	SW	SWITCH
HH	HANDHOLE	SWD	SWITCHED
HPS	HIGH PRESSURE SODIUM	TDW	TELEPHONE DROP WIRE
JB	JUNCTION BOX	WLK	WALK
LUM	LUMINAIRE	YEL	YELLOW
NEU	NEUTRAL	YLTA	YELLOW LEFT TURN ARROW
NMC	NONMETALLIC CONDUIT	YRTA	YELLOW RIGHT TURN ARROW
		YTHA	YELLOW THRU ARROW

CONDUCTOR COLOR CODE

R	RED
O	ORANGE
BL	BLUE
WH	WHITE
R/BLK	RED WITH BLACK TRACER
O/BLK	ORANGE WITH BLACK TRACER
BL/BLK	BLUE WITH BLACK TRACER
WH/BLK	WHITE WITH BLACK TRACER
BLK	BLACK
BLK/WH	BLACK WITH WHITE TRACER
G/BLK	GREEN WITH BLACK TRACER
G	GREEN

STANDARD PLATES
THESE STANDARD PLATES AS APPROVED BY FHWA SHALL APPLY:

PLATE NO.	DESCRIPTION
* M8110 D	TRAFFIC SIGNAL BRACKETING - POLE MOUNTED
M8111 C	TRAFFIC SIGNAL BRACKETING - PEDESTAL MOUNTED
M8112 C	PEDESTAL FOUNDATION
* M8114 A	PVC HANDHOLE/PULLBOX
M8115 D	PEDESTRIAN PUSH BUTTON INSTALLATION
M8118 C	SERVICE EQUIPMENT AND POLE-TRAFFIC CONTROL SIGNALS
* M8119 C	GROUND MOUNTED CABINET FOUNDATION
M8120 K	PA85 POLE FOUNDATION
M8121 D	TRANSFORMER BASE AND POLE BASE PLATE
M8122 C	PEDESTAL AND PEDESTAL BASE
M8123 D	POLE AND MAST ARM
* M8124 E	MAST ARM SIGNAL HEAD MOUNTS
M8126 F	PA90 AND PA100 POLE FOUNDATION

* - APPLIES TO THIS PROJECT

1	JMG 11/9	PER MN/DOT COMMENTS							
NO.	BY	DATE	REVISIONS	ITEM	DESIGN	CHECKED			

I hereby certify that this plan was prepared by me or under my direct supervision and that I am a duly Registered Professional Engineer under the laws of the state of Minnesota.
Date: 11/12/98 Reg. No. 22457



ANOKA COUNTY, MINNESOTA
CITY OF ANDOVER
S.P. 02-678-12
S.P. 02-716-02

TRAFFIC SIGNAL SYSTEM
DETAILS & STANDARD PLATES
HANSON BOULEVARD NW (CSAH 78) AT
BUNKER LAKE BOULEVARD NW (CSAH 116)

FILE NO.	ANOKC9708	17
DATE	3/16/98	59

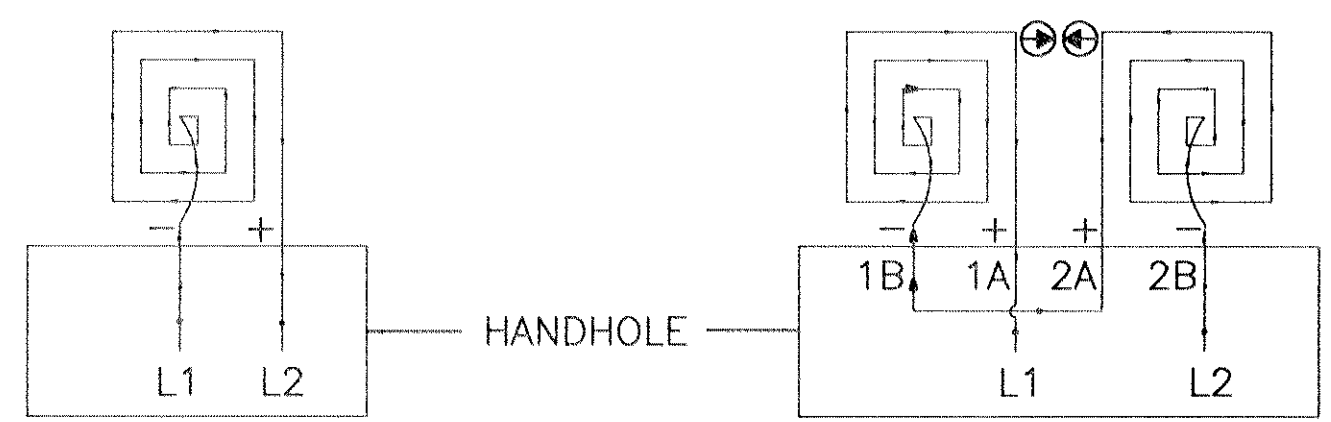
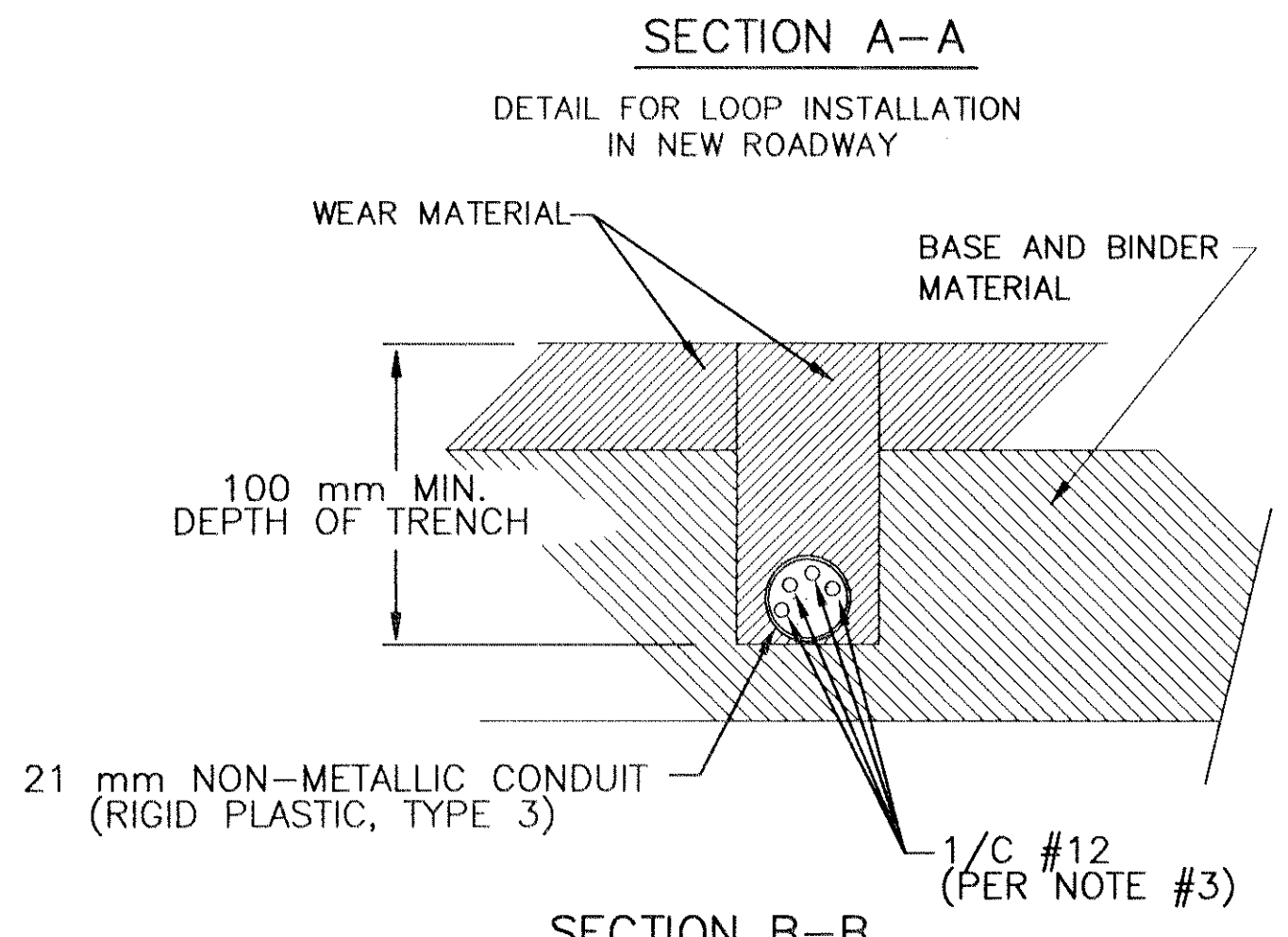
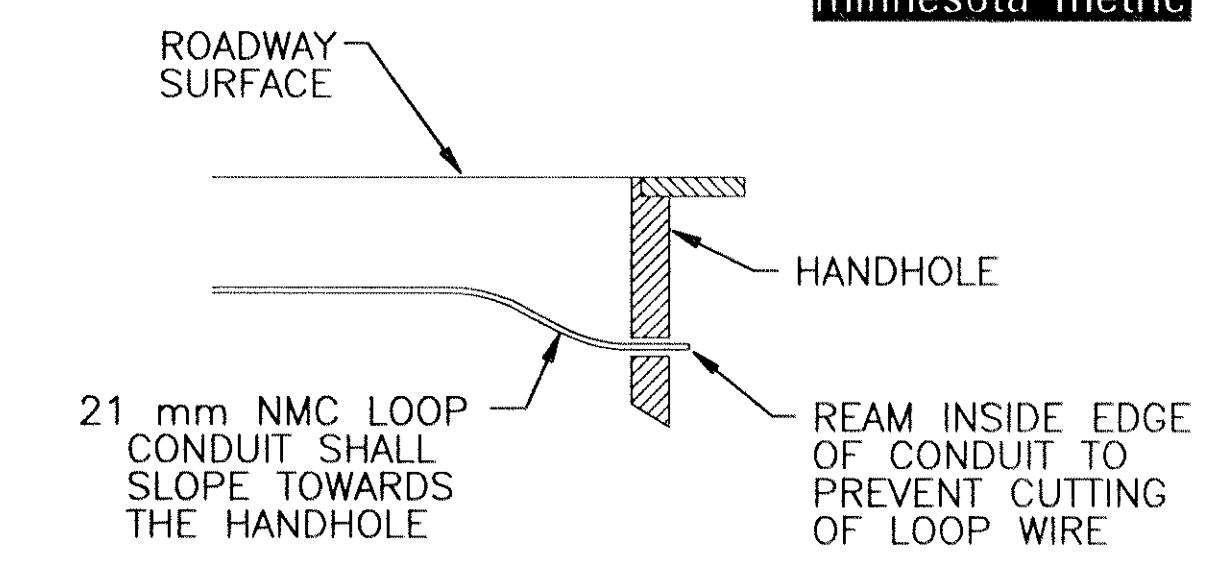
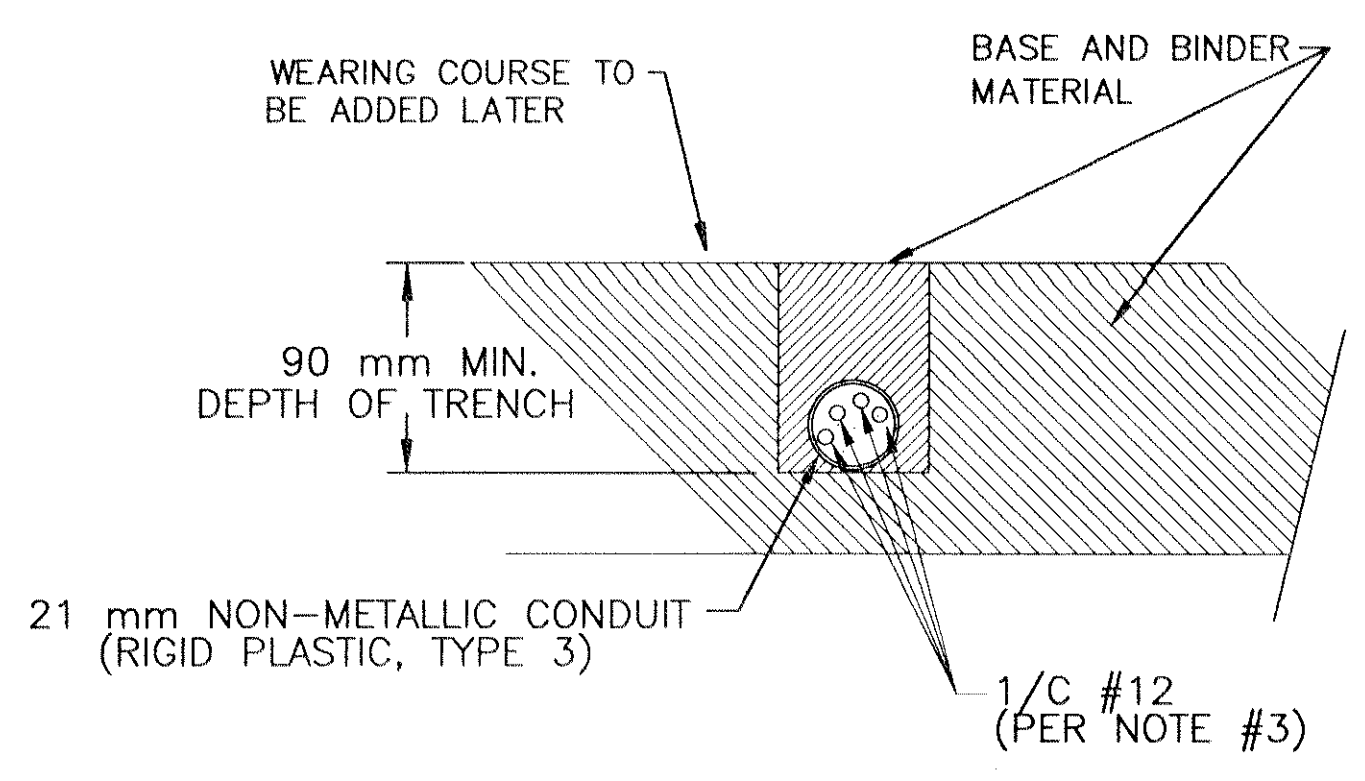
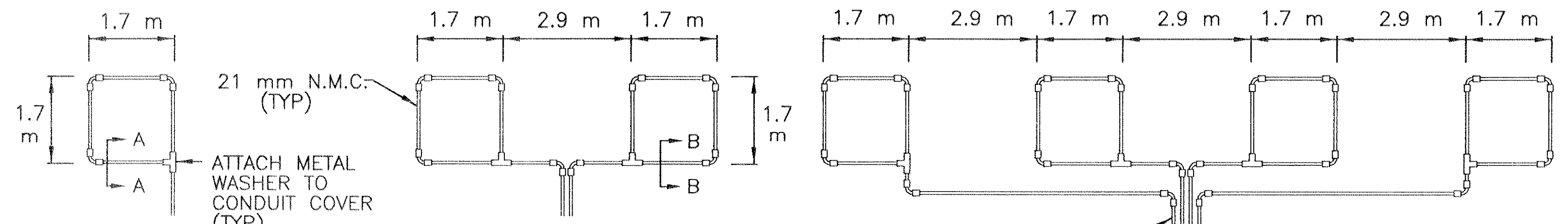

**LOOP DETECTOR
DETAIL 'A'**
(LOOP PHASING FOR
SINGLE CONNECTION)

LOOP CONNECTIONS SHALL BE
LABELED AND SPLICED IN THE
HANDHOLE AS FOLLOWS:

- L1 TO 1A
- 1B TO 2A
- 2B TO L2

**LOOP DETECTOR
DETAIL 'B'**
(LOOP PHASING FOR
SERIES CONNECTION)

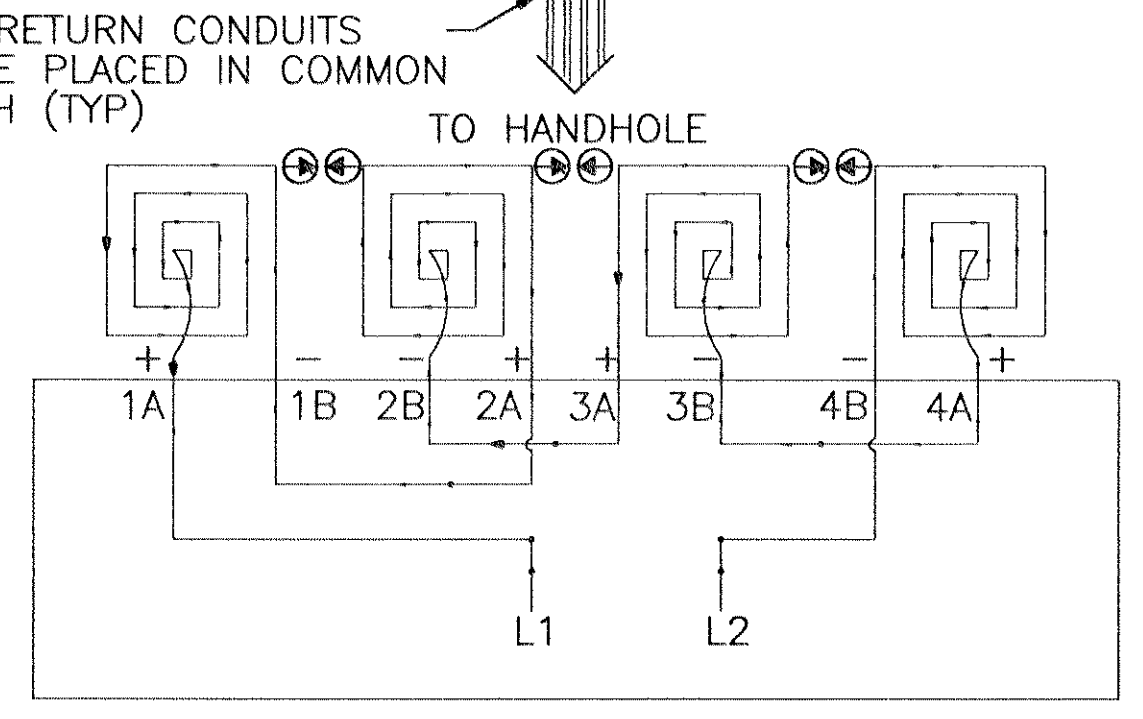

LOOP CONNECTIONS SHALL BE LABELED AND SPLICED
IN THE HANDHOLE AS FOLLOWS:

- L1 TO 1A 3B TO 4A
- 1B TO 2A 4B TO L2
- 2B TO 3A

SPLICE CONTROL CABLE TO L1 & L2 IN HANDHOLE.
ALL CONDUCTORS SHALL BE TAGGED IN HANDHOLE
(1A, 1B, ECT)

**LOOP DETECTOR
DETAIL 'C'**
(LOOP PHASING FOR
SERIES CONNECTION)

- LOOP DETECTOR WIRING**
- 1) ALL CORNERS SHALL BE 90° CONDUIT BENDS.
 - 2) CONNECT WIRES IN HANDHOLES USING SPLICE KIT METHOD DESCRIBED IN THE SPECIAL PROVISIONS.
 - 3) LOOP DETECTOR WIRES SHALL BE #12 AWG CROSSED LINKED POLYETHYLENE (XLP). SEE SPECIAL PROVISIONS.
 - 4) LOOP LEAD IN WIRES SHALL BE TWISTED A MIN. OF (5) TURNS PER 0.3 METER (1 FOOT) THROUGH THE CONDUIT TO THE HANDHOLE.
 - 5) NMC DESIGNATES NON-METALLIC CONDUIT (SPEC. 3803)
 - 6) LOOPS 1.7 m x 1.7 m THRU 1.7 m x 4.3 m SHALL HAVE (4) TURNS.
 - 7) LOOPS 1.7 m x 4.6 m AND LARGER SHALL HAVE (2) TURNS.

LEGEND OF SYMBOLS

CONTROLLER AND SERVICE EQUIP. NO's	(A)
SIGNAL BASE NO.	(1)
SIGNAL FACE NO.	(-)
LUMINAIRE NO.	(A)
CONTROLLER AND CABINET	(C)
CONTROLLER AND CABINET - IN PLACE	(C)
HANDHOLE	(H)
HANDHOLE - IN PLACE	(H)
RIGID STEEL CONDUIT (RSC)	(RSC)
RIGID STEEL CONDUIT (RSC) - IN PLACE	(RSC)
SIGNAL FACE WITH BACKGROUND SHIELD	(S)
SIGNAL FACE W/O BACKGROUND SHIELD	(S)
SIGNAL FACE - IN PLACE	(S)
PEDESTRIAN INDICATORS	(P)
PEDESTRIAN INDICATORS - IN PLACE	(P)
PEDESTRIAN PUSH BUTTONS ON PEDESTAL OR POLE	(PB)
PEDESTRIAN PUSH BUTTON STATION	(PB)
TRAFFIC SIGNAL PEDESTAL	(T)
TRAFFIC SIGNAL PEDESTAL - IN PLACE	(T)
TRAFFIC SIGNAL POLE AND MAST ARM	(P)
TRAFFIC SIGNAL POLE AND MAST ARM - IN PLACE	(P)
STREET LIGHT POLE AND LUMINAIRE	(S)
STREET LIGHT POLE AND LUMINAIRE - IN PLACE	(S)
MAST ARM AND LUMINAIRE	(M)
MAST ARM AND LUMINAIRE - IN PLACE	(M)
WOOD POLE	(W)
WOOD POLE - IN PLACE	(W)
SOURCE OF POWER	(S)
RAILROAD SIGNAL - IN PLACE	(R)
RIGHT OF WAY LINE	(R)
CENTERLINE	(C)
EDGE OF ROADWAY	(E)
SHOULDERLINE	(S)
CURB LINE	(C)
STOP BAR	(S)

ABBREVIATIONS

3-1(EG)	SIGNAL HEAD PHASE "3" - NO "1"	P2-1(EG)	PEDESTRIAN INDICATION PHASE "2" - NO. "1"
BR. GR.	BARE GROUND	PB	PUSH BUTTON
CH. SW.	CHECK SWITCH	PB2-1(EG)	PUSH BUTTON PHASE "2" - NO. "1"
CLR	CLEAR	PEC	PHOTOELECTRIC CELL
D2-1(EG)	DETECTOR PHASE "2" - NO. "1"	PED	PEDESTRIAN
DWK	DON'T WALK	R	RED
EQG	EQUIPMENT GROUND	R&S	REMOVE AND SALVAGE
EVP	EMERGENCY VEHICLE PRE-EMPTION	RLTA	RED LEFT TURN ARROW
F&I	FURNISH AND INSTALL	RRTA	RED RIGHT TURN ARROW
FL	FLASH/FLASHING	RSC	RIGID STEEL CONDUIT
G	GREEN	S&R	SALVAGE AND REINSTALL
GLTA	GREEN LEFT TURN ARROW	SOP	SOURCE OF POWER
GRN	GREEN	SPR	SPARE
GR. R	GROUND ROD	ST. LHT	STREET LIGHT
GRTA	GREEN RIGHT TURN ARROW	STA	STATION
GTHA	GREEN THRU ARROW	SW	SWITCH
HH	HANDHOLE	SWD	SWITCHED
HPS	HIGH PRESSURE SODIUM	TDW	TELEPHONE DROP WIRE
JB	JUNCTION BOX	WLK	WALK
LUM	LUMINAIRE	YEL	YELLOW
NEU	NEUTRAL	YLTA	YELLOW LEFT TURN ARROW
NMC	NONMETALLIC CONDUIT	YRTA	YELLOW RIGHT TURN ARROW
		YTHA	YELLOW THRU ARROW

CONDUCTOR COLOR CODE

R	RED		
O	ORANGE		
BL	BLUE		
WH	WHITE		
R/BLK	RED WITH BLACK TRACER		
O/BLK	ORANGE WITH BLACK TRACER		
BL/BLK	BLUE WITH BLACK TRACER		
WH/BLK	WHITE WITH BLACK TRACER		
BLK	BLACK		
BLK/WH	BLACK WITH WHITE TRACER		
G/BLK	GREEN WITH BLACK TRACER		
G	GREEN		

STANDARD PLATES

THESE STANDARD PLATES AS APPROVED BY FHWA SHALL APPLY:

PLATE NO.	DESCRIPTION
* M8110 D	TRAFFIC SIGNAL BRACKETING - POLE MOUNTED
M8111 C	TRAFFIC SIGNAL BRACKETING - PEDESTAL MOUNTED
M8112 C	PEDESTAL FOUNDATION
* M8114 A	PVC HANDHOLE/PULLBOX
M8115 D	PEDESTRIAN PUSH BUTTON INSTALLATION
M8117 F	PRECAST CONCRETE HANDHOLE
M8118 C	SERVICE EQUIPMENT AND POLE-TRAFFIC CONTROL SIGNALS
* M8119 C	GROUND MOUNTED CABINET FOUNDATION
M8120 K	PA85 POLE FOUNDATION
M8121 D	TRANSFORMER BASE AND POLE BASE PLATE
M8122 C	PEDESTAL AND PEDESTAL BASE
M8123 D	POLE AND MAST ARM
* M8124 E	MAST ARM SIGNAL HEAD MOUNTS
M8126 F	PA90 AND PA100 POLE FOUNDATION

* - APPLIES TO THIS PROJECT

I hereby certify that this plan was prepared by me or under my direct supervision and that I am a duly Registered Professional Engineer under the laws of the state of Minnesota.

Date: 3/16/98 Reg. No. 22457



ANOKA COUNTY, MINNESOTA
CITY OF ANDOVER
S.P. 02-678-12
S.P. 02-716-02

TRAFFIC SIGNAL SYSTEM
DETAILS & STANDARD PLATES
HANSON BOULEVARD NW (CSAH 78) AT
BUNKER LAKE BOULEVARD NW (CSAH 116)

FILE NO. ANOKC9708
DATE 3/16/98
17
59

NO.	BY	DATE	REVISIONS	ITEM	DESIGN	CHECKED

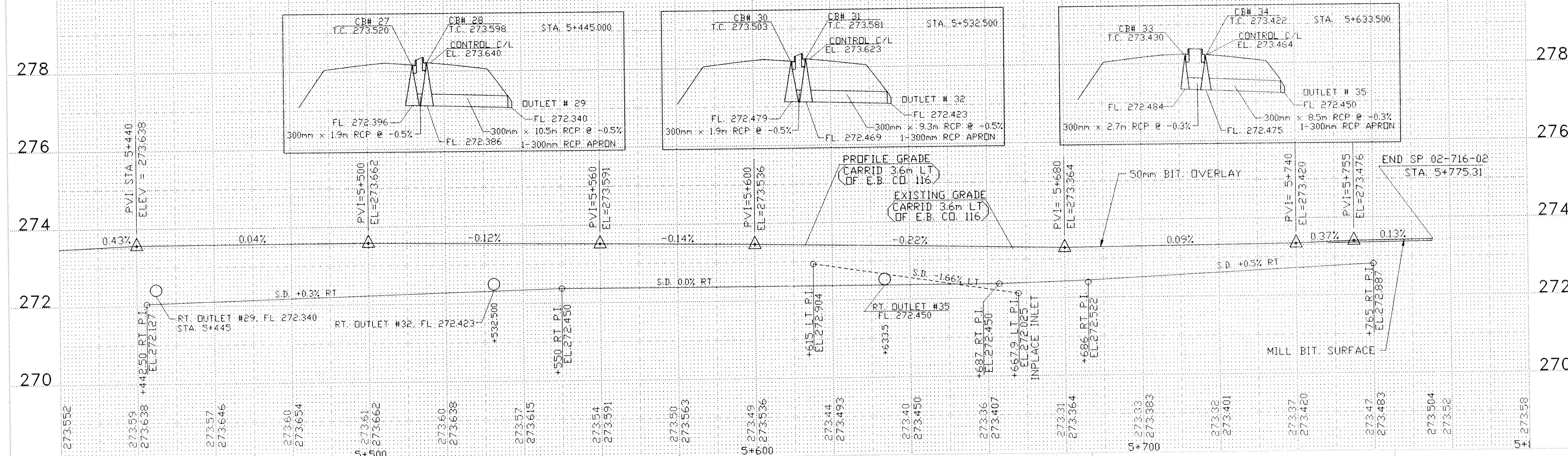
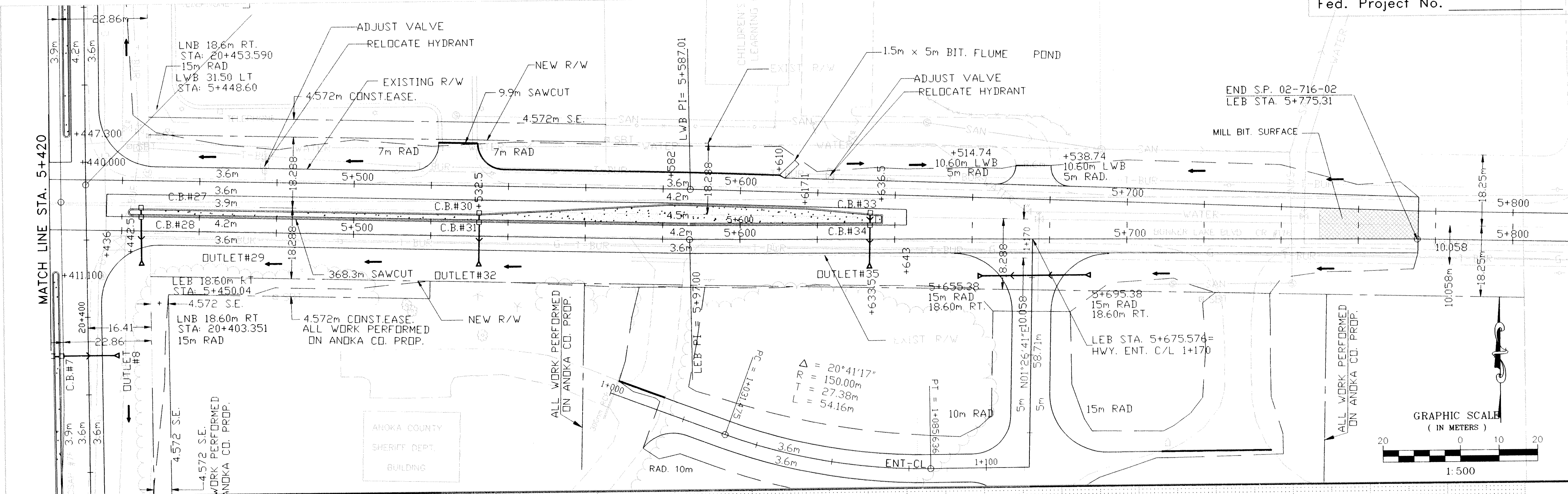

NO	DATE	BY	CKD	APPR	REVISION

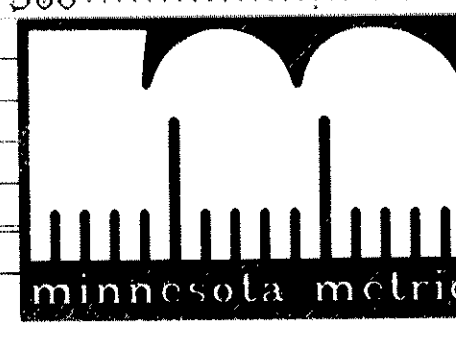

I HEREBY CERTIFY THAT THIS PLAN WAS PREPARED BY ME OR UNDER MY DIRECT SUPERVISION AND THAT I AM A DULY REGISTERED PROFESSIONAL ENGINEER UNDER THE LAWS OF THE STATE OF MINNESOTA.

DATE _____ REG. NO. _____

DRAWN BY _____ DATE 02/27/98
 DESIGN BY DWE DATE 04/27/98
 CHECKED BY DWE DATE 04/27/98

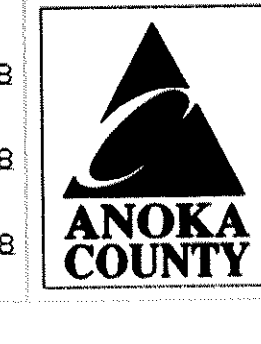

**ANOKA COUNTY
HIGHWAY DEPT.**

STATE PROJECT NO. 02-678-12/02-716-02
 STATE AID PROJECT NO. _____
 STATE AID PROJECT NO. _____
 COUNTY PROJECT NO. _____

PLAN AND PROFILE
 C.S.A.H. 116
 STA. 5+420.00 TO STA. 5+800.00
 Sheet 16 of 59 Sheets

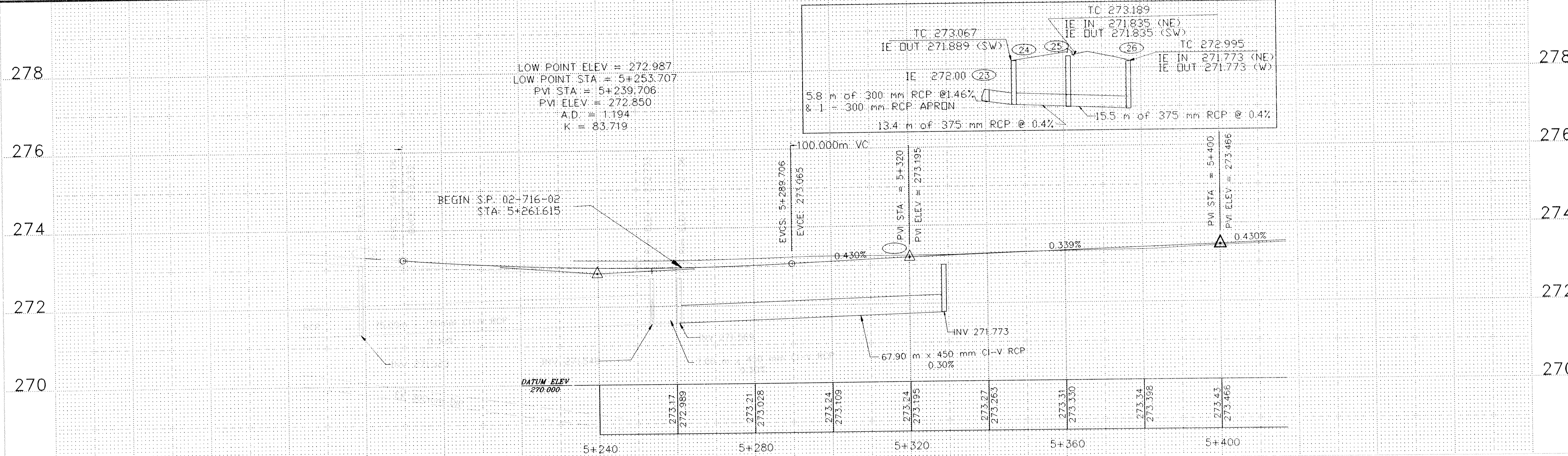
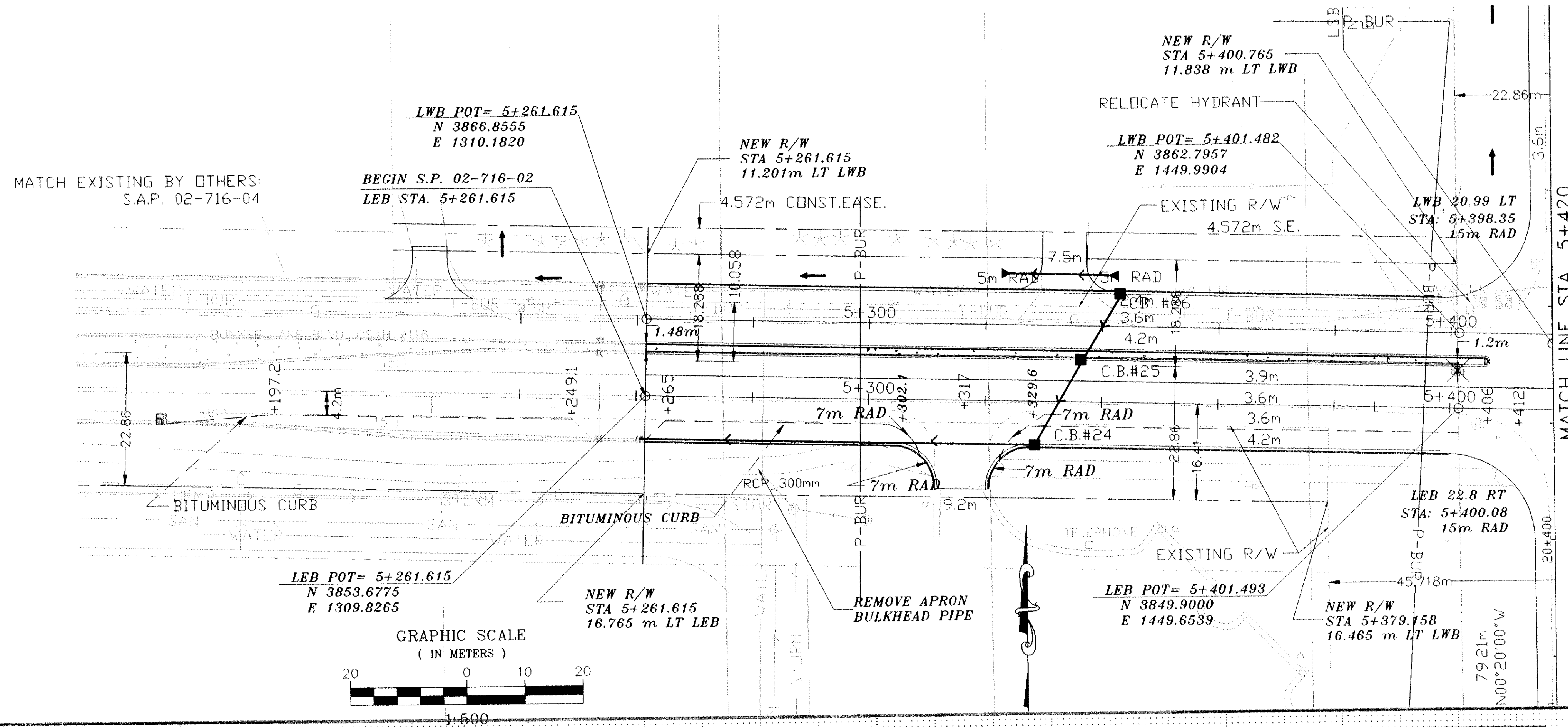

1	6/15/99	KLD	LAR		The west leg of CSAH 116 was revised from rural to urban section. The project limits were changed to match with S.A.P. 02-716-04.
ND	DATE	BY	CKD	APPR	REVISION
NAME: E:\0267812\WDRK\SH2-3					2-4-98 2:16:20 pm EST

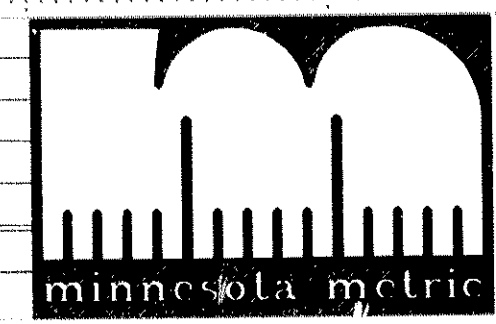

I HEREBY CERTIFY THAT THIS PLAN WAS PREPARED BY ME OR UNDER MY DIRECT SUPERVISION AND THAT I AM A DULY REGISTERED PROFESSIONAL ENGINEER UNDER THE LAWS OF THE STATE OF MINNESOTA.

DATE _____ REG. NO. _____

DRAWN BY MN DATE 02/27/98
DESIGN BY DWF DATE 04/27/98
CHECKED BY DWF DATE 04/27/98

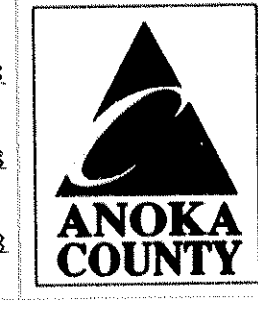

**ANOKA COUNTY
HIGHWAY DEPT.**

STATE PROJECT NO. 02-678-12/02-716-02
STATE AID PROJECT NO. _____
STATE AID PROJECT NO. _____
COUNTY PROJECT NO. _____

PLAN AND PROFILE
C.S.A.H. 116
STA. 5+040.00 TO STA. 5+420.00
Sheet 15 of 59 Sheets

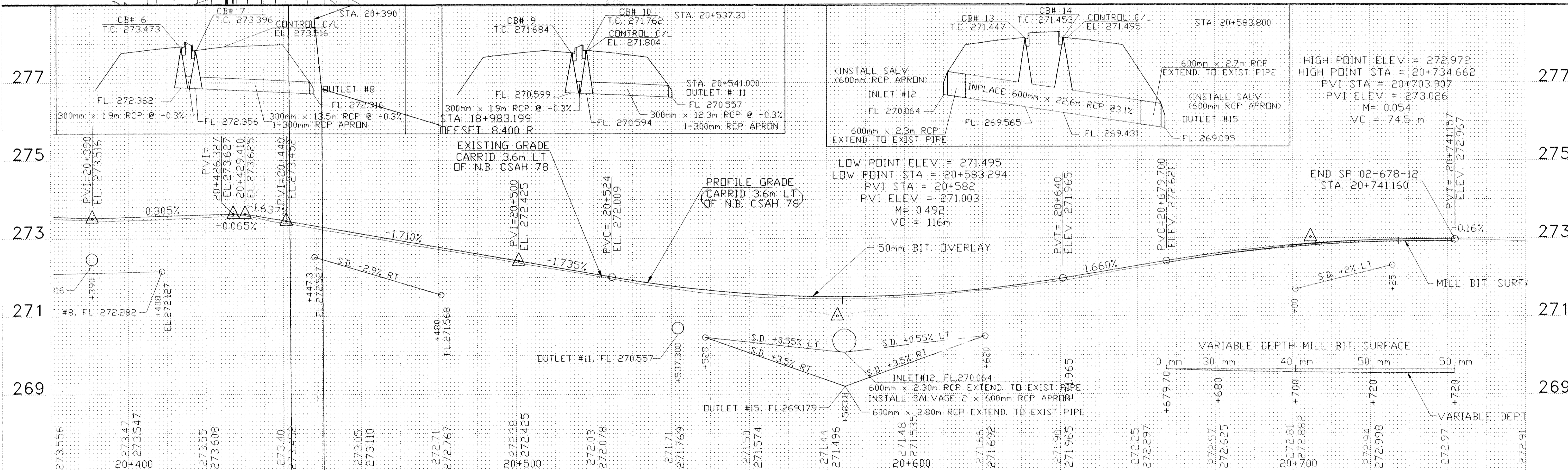
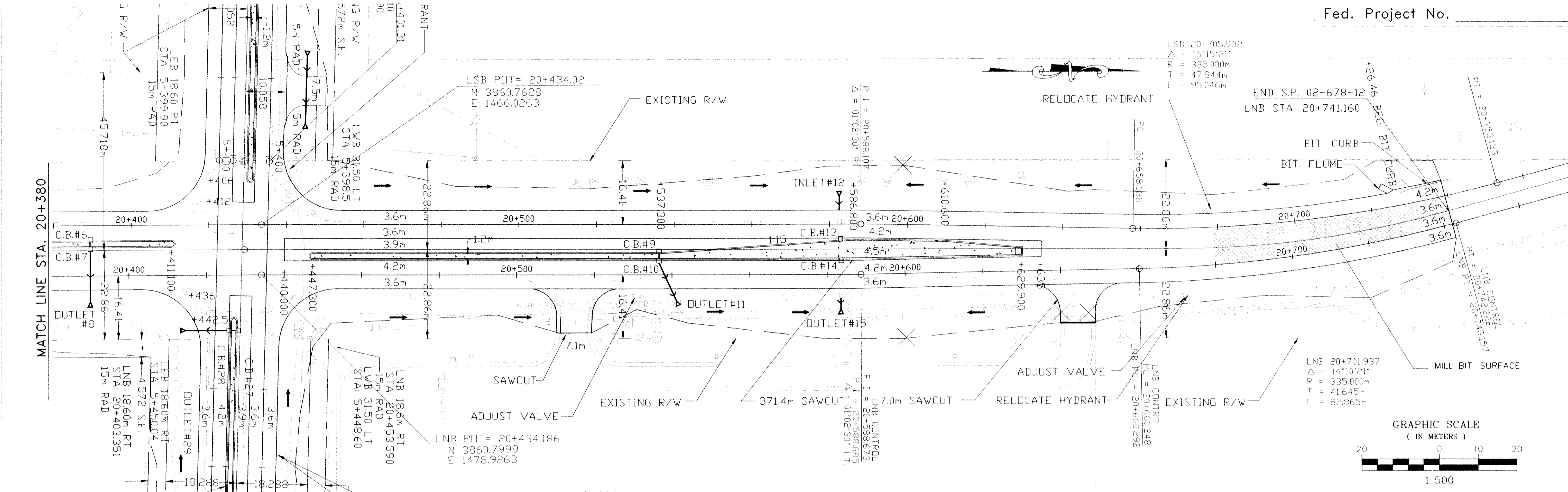

NO	DATE	BY	CKD	APPR	REVISION
1	04-27-98	MN	DWF		
2	04-27-98	DWF			
3	04-27-98	DWF			

I HEREBY CERTIFY THAT THIS PLAN WAS PREPARED BY ME OR UNDER MY DIRECT SUPERVISION AND THAT I AM A DULY REGISTERED PROFESSIONAL ENGINEER UNDER THE LAWS OF THE STATE OF MINNESOTA.

DRAWN BY: MN DATE 04-27-98
 DESIGN BY: DWF DATE 04-27-98
 CHECKED BY: DWF DATE 04-27-98

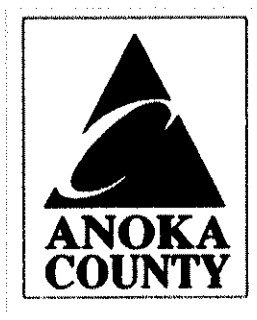

ANOKA COUNTY
HIGHWAY DEPT.

STATE PROJECT NO. 02-678-12/02-716-02
 STATE AID PROJECT NO. _____
 STATE AID PROJECT NO. _____
 COUNTY PROJECT NO. _____

PLAN AND PROFILE
 C.S.A.H. 78
 STA. 20+380.00 TO 20+780.00
 Sheet 14 of 59 Sheets

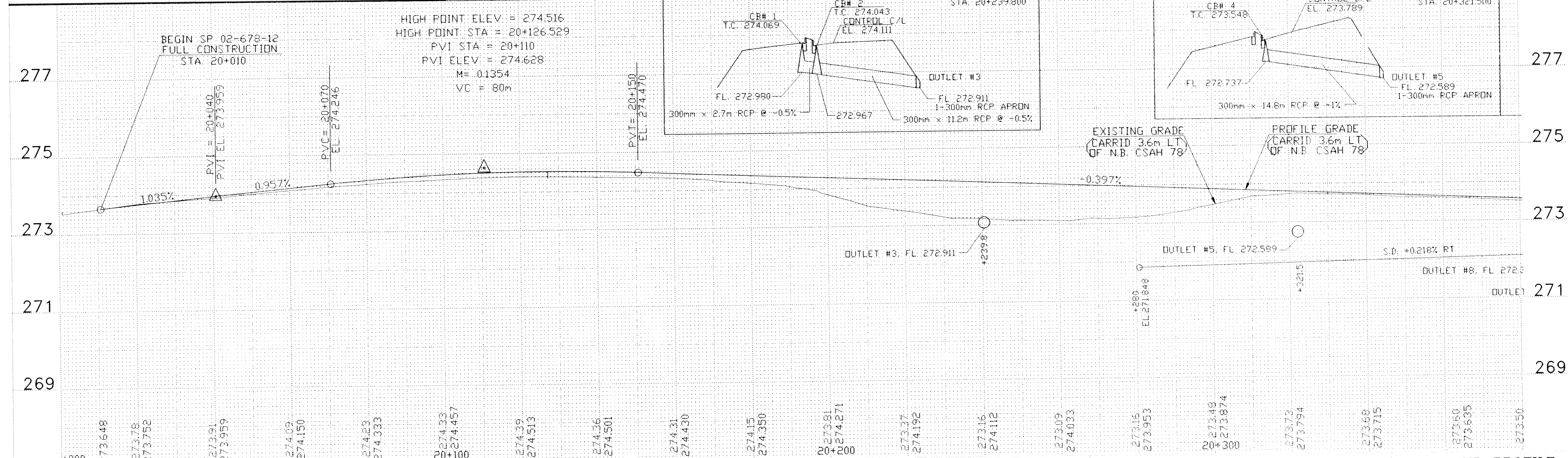
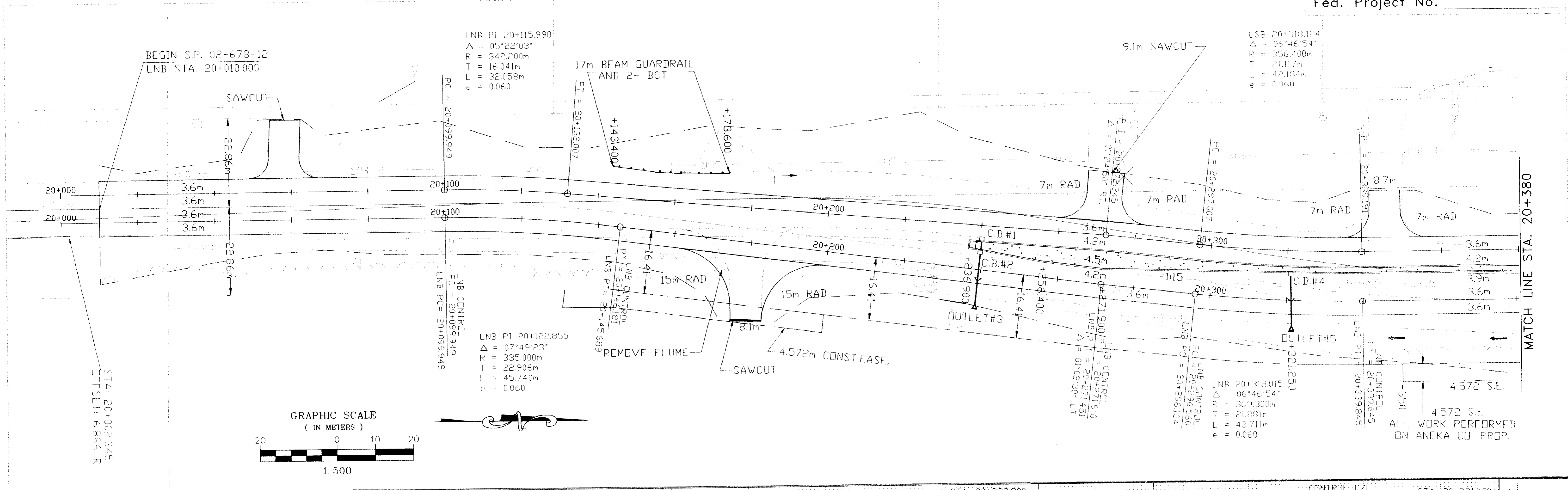

NO	DATE	BY	CKD	APPR	REVISION

NAME: SHI-2.dwg 42998 23148

minnesota metric

I HEREBY CERTIFY THAT THIS PLAN WAS PREPARED BY ME OR UNDER MY DIRECT SUPERVISION AND THAT I AM A DULY REGISTERED PROFESSIONAL ENGINEER UNDER THE LAWS OF THE STATE OF MINNESOTA.

DATE _____ REG. NO. _____

ANOKA COUNTY

STATE PROJECT NO. 02-678-12/02-716-02
 STATE AID PROJECT NO. _____
 STATE AID PROJECT NO. _____
 COUNTY PROJECT NO. _____

ANOKA COUNTY HIGHWAY DEPT.

PLAN AND PROFILE
 C.S.A.H. 78
 STA. 20+000.00 TO 20+380.00
 Sheet 13 of 59 Sheets

HANSON BLVD. CSAH 78

Fed. Project No. _____

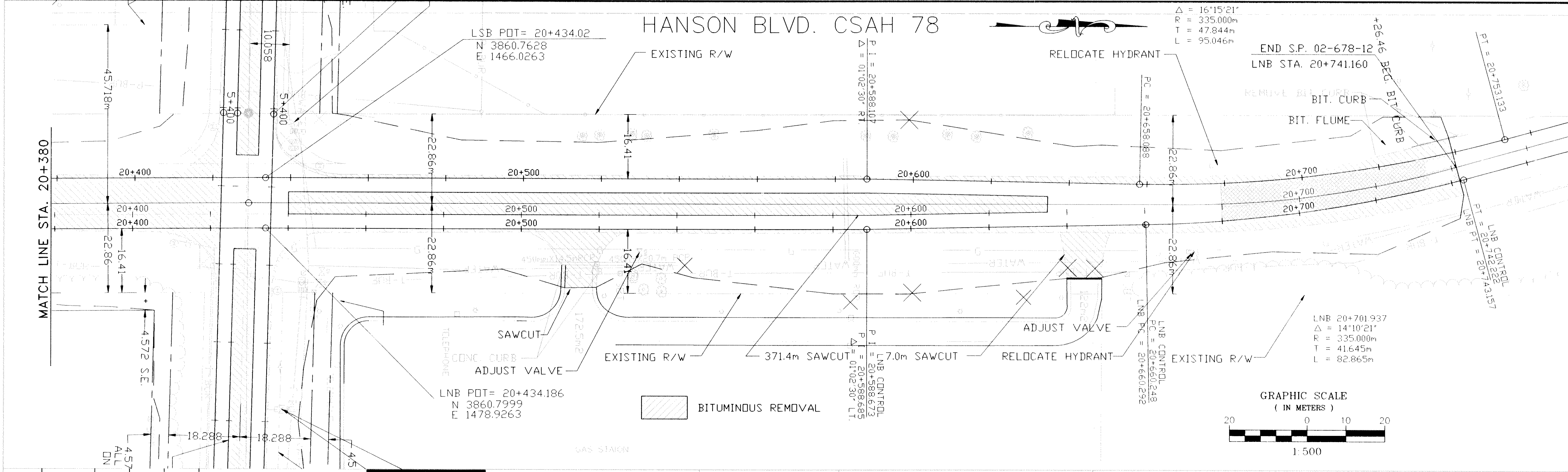
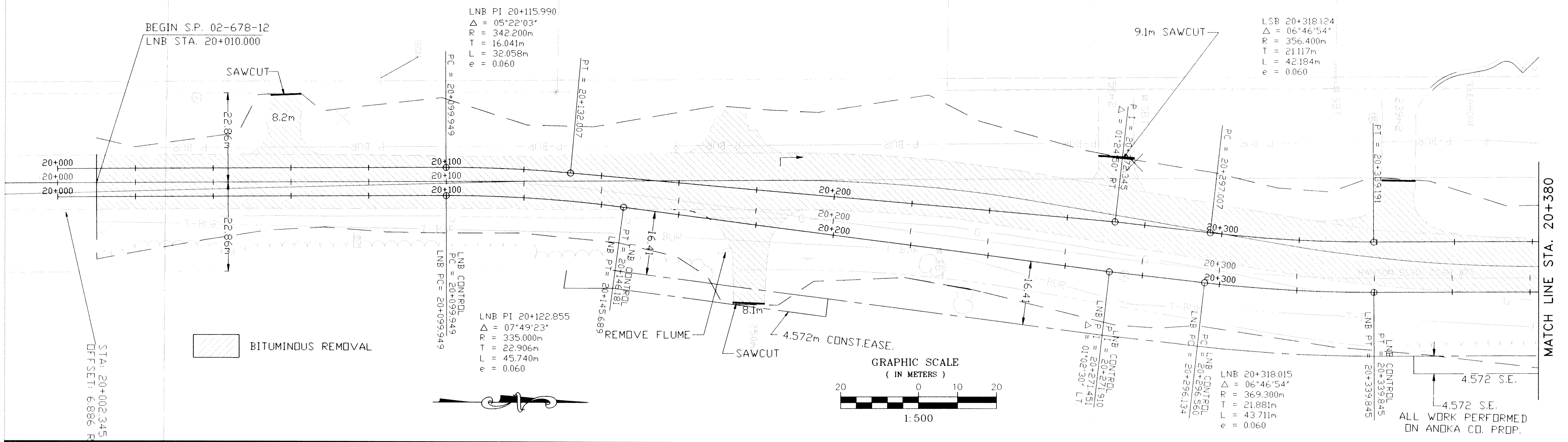

NO	DATE	BY	CKD	APPR	REVISION
1	04/27/98	DWF			DESIGN
2	04/27/98	DWF			CHECKED



I HEREBY CERTIFY THAT THIS PLAN WAS PREPARED BY ME OR UNDER MY DIRECT SUPERVISION AND THAT I AM A DULY REGISTERED PROFESSIONAL ENGINEER UNDER THE LAWS OF THE STATE OF MINNESOTA.

DATE _____ REG. NO. _____

DRAWN BY: MN DATE 04/27/98
 DESIGN BY: DWF DATE 04/27/98
 CHECKED BY: DWF DATE 04/27/98



**ANOKA COUNTY
HIGHWAY DEPT.**

STATE PROJECT NO. 02-678-12/ 02-716-02
 STATE AID PROJECT NO. _____
 STATE AID PROJECT NO. _____
 COUNTY PROJECT NO. _____

**EXISTING CONDITIONS
AND REMOVALS PLAN**
 C.S.A.H. 78
 Sheet 12 of 59 Sheets

BUNKER LAKE BLVD. CSAH 116

Fed. Project No.
 STA 02-716-02
 11.838 m LT LWB

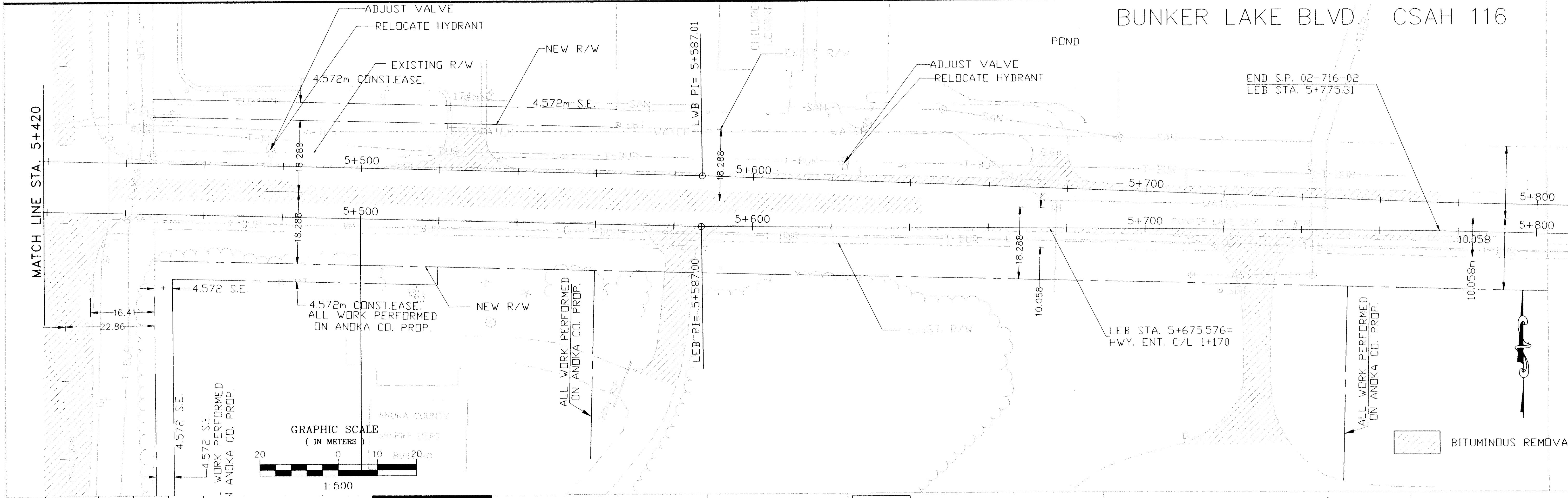
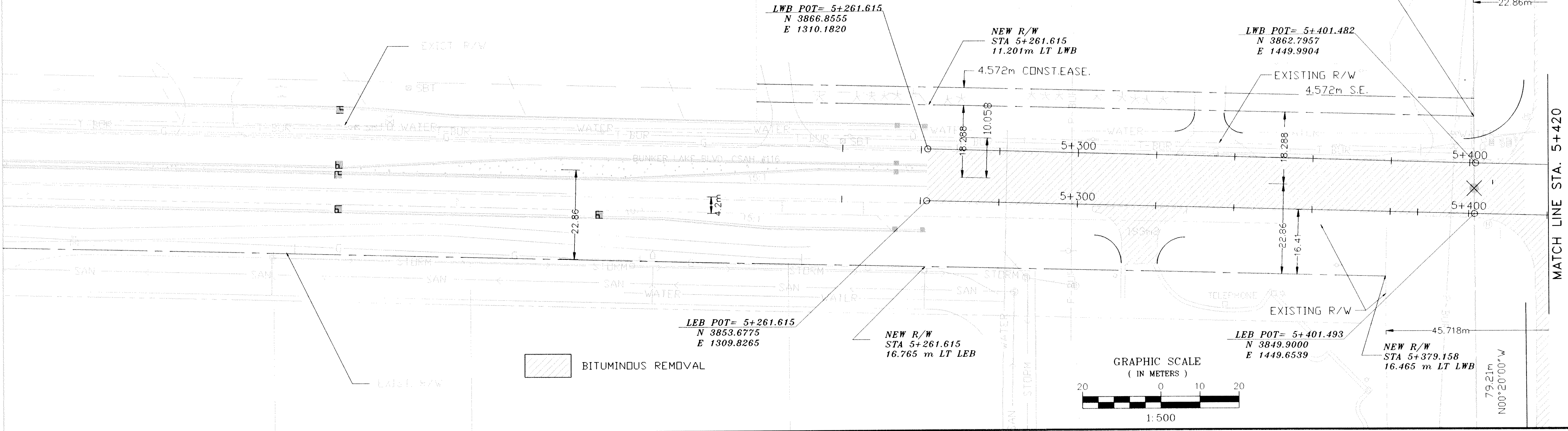

1	6/15/99	KLO	LAR	Hatching for removals was revised to reflect change from rural to urban section and project limits were revised to match with S.A.P. 02-716-04	
NO	DATE	BY	CKD	APPR	REVISION
NAME:	REM-SH.dwg	31898	34550		

minnesota metric



I HEREBY CERTIFY THAT THIS PLAN WAS PREPARED BY ME OR UNDER MY DIRECT SUPERVISION AND THAT I AM A DULY REGISTERED PROFESSIONAL ENGINEER UNDER THE LAWS OF THE STATE OF MINNESOTA.

DATE _____ REG. NO. _____

DRAWN BY: MN DATE 04/27/98
 DESIGN BY: DWF DATE 04/27/98
 CHECKED BY: DWF DATE 04/27/98

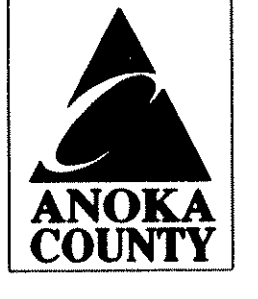

ANOKA COUNTY
 HIGHWAY DEPT.

STATE PROJECT NO. 02-678-12/ 02-716-02
 STATE AID PROJECT NO. _____
 STATE AID PROJECT NO. _____
 COUNTY PROJECT NO. _____

EXISTING CONDITIONS
 AND REMOVALS PLAN
 C.S.A.H. 116
 Sheet 11 of 59 Sheets

MILLING DETAILS

BITUMINOUS CURB DETAIL

STANDARD PLATE NO. M7065C
(USE IN BERM LOCATIONS)
FOR LOCATIONS SEE CHART (P)

TYPICAL UNPAVED ENTRANCE

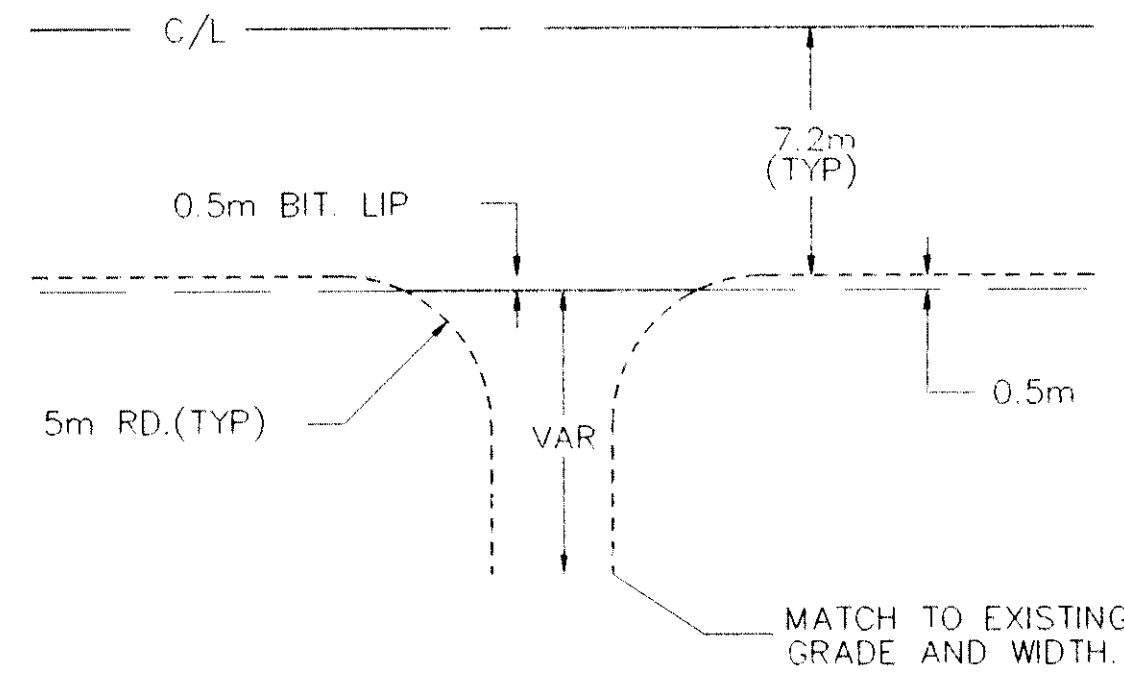

NOTE: ENTRANCE INSLOPE SHALL BE 1:6.

BUTT JOINTS (PLAN VIEW)

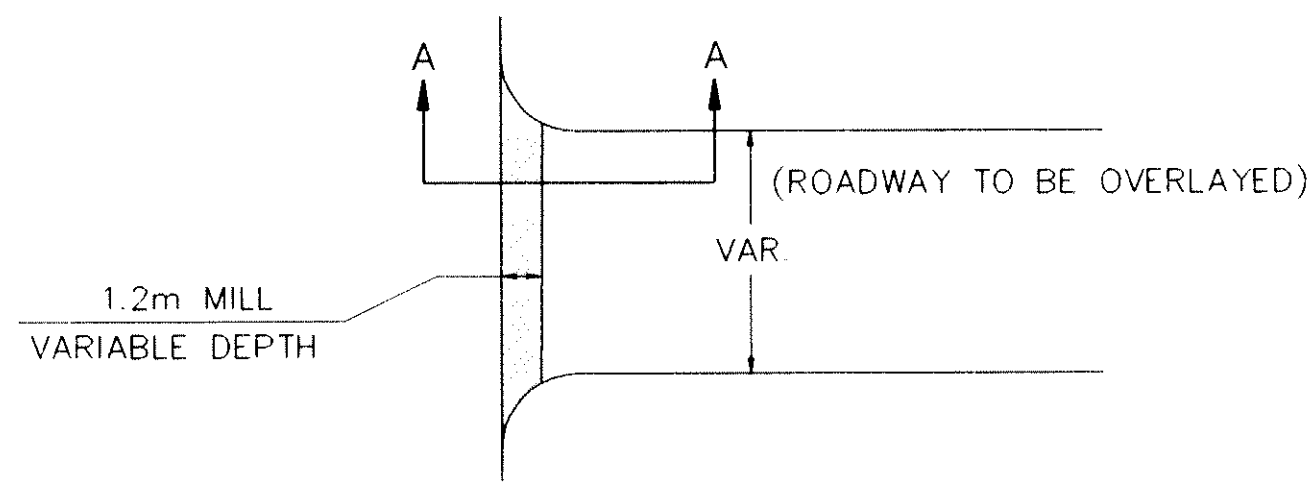

SECTION A-A

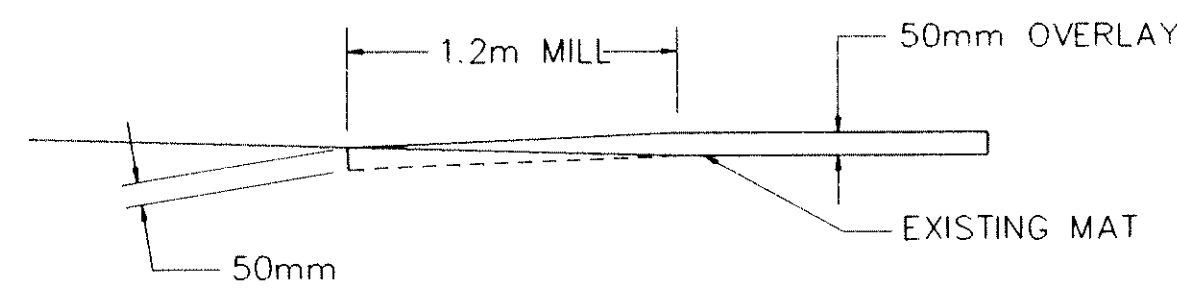

EDGE OF ROAD AS SHOWN ON PLAN

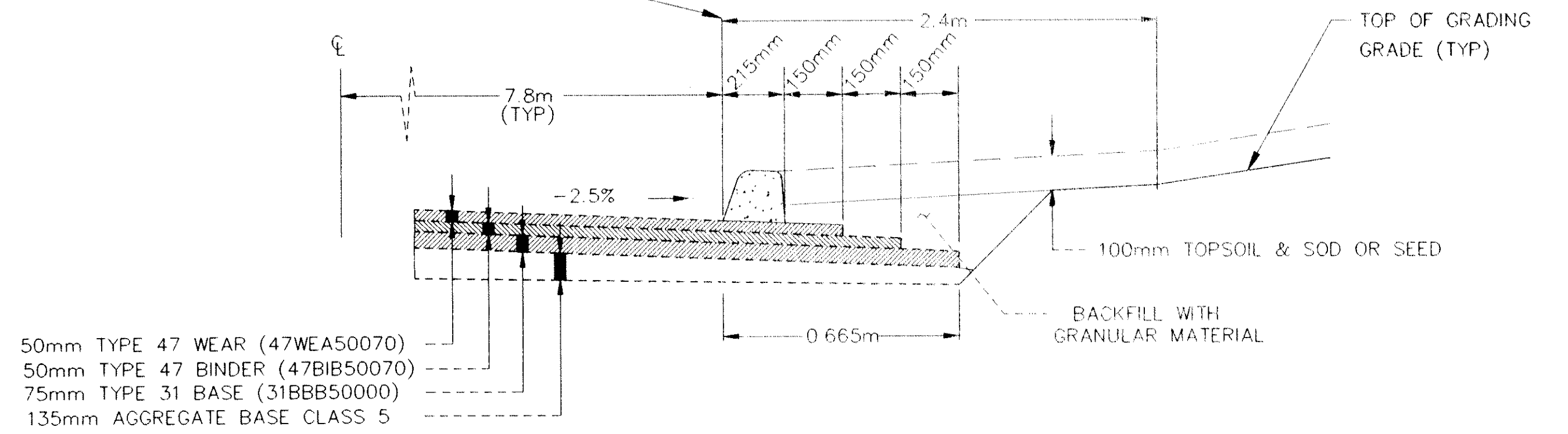

GRADING BERM

FOR LOCATIONS SEE CHART (P)

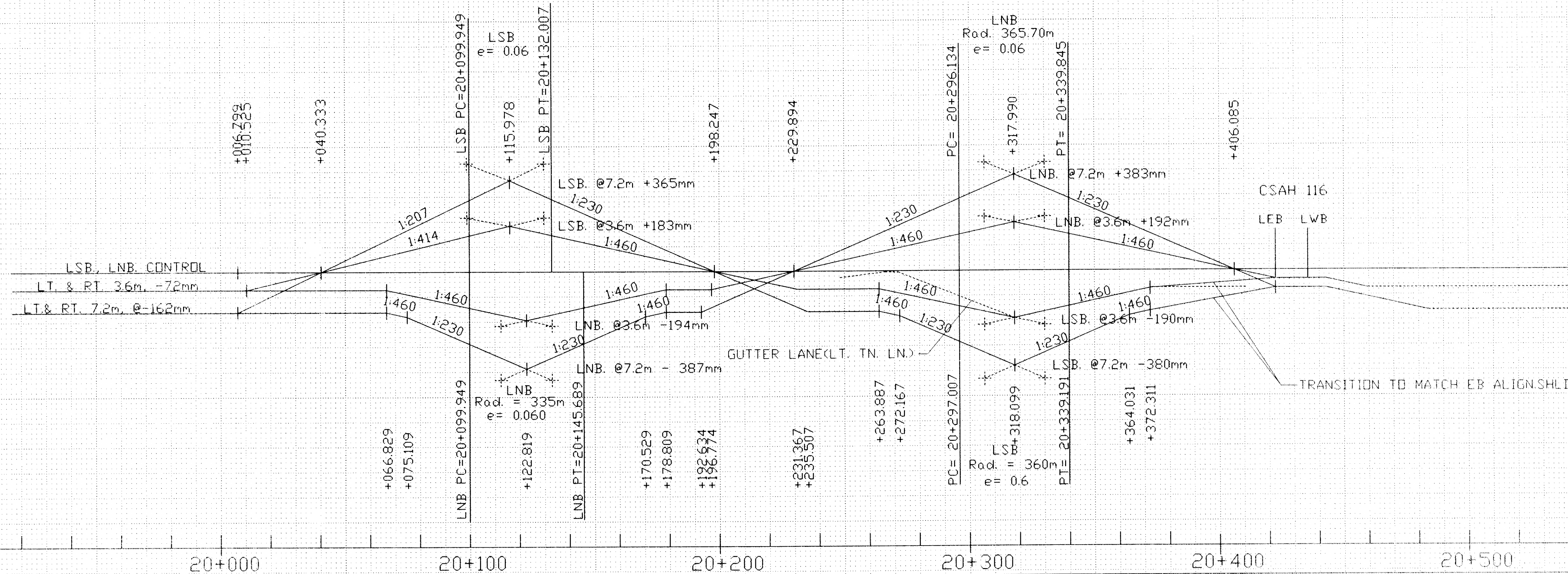
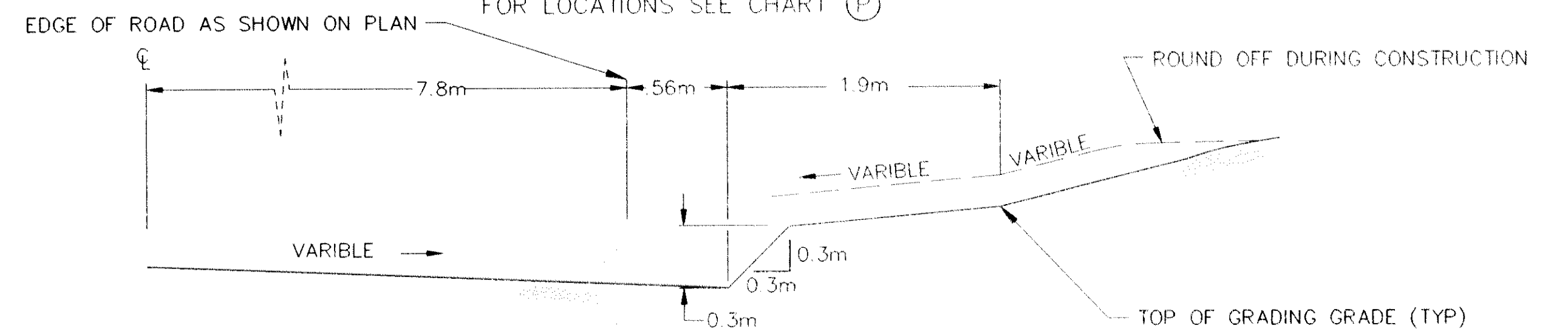

NO	DATE	BY	CKD	APPR	REVISION



I HEREBY CERTIFY THAT THIS PLAN WAS PREPARED BY ME OR UNDER MY DIRECT SUPERVISION AND THAT I AM A DULY REGISTERED PROFESSIONAL ENGINEER UNDER THE LAWS OF THE STATE OF MINNESOTA.

DATE _____ REG. NO. _____

DRAWN BY: MN DATE: 04/27/98
DESIGN BY: DWF DATE: 04/27/98
CHECKED BY: DWF DATE: 04/27/98

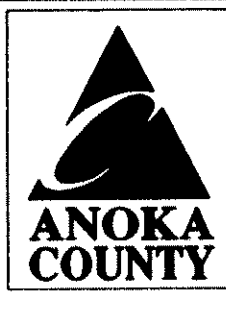

ANOKA COUNTY
HIGHWAY DEPT.

STATE PROJECT NO. 02-678-12, 02-716-02
STATE AID PROJECT NO. _____
STATE AID PROJECT NO. _____
COUNTY PROJECT NO. _____

DETAIL AND
SUPERELEVATION
Sheet 10 of 59 Sheets

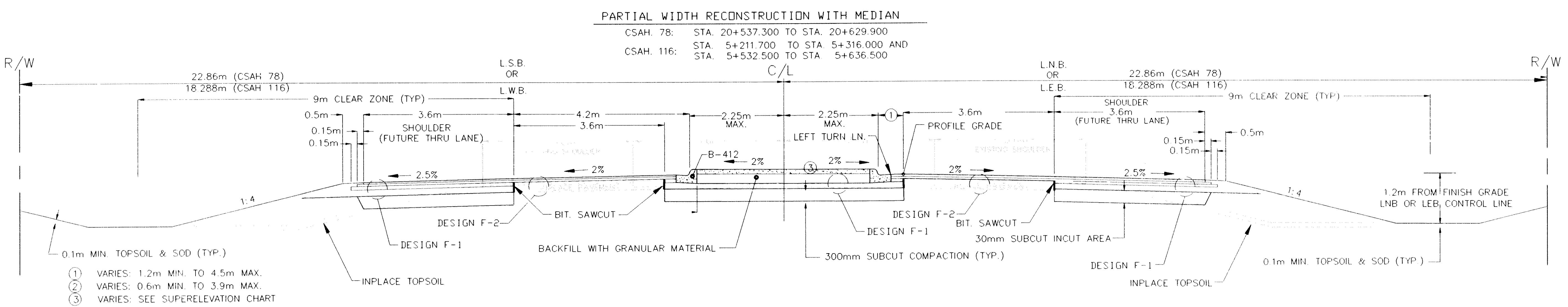
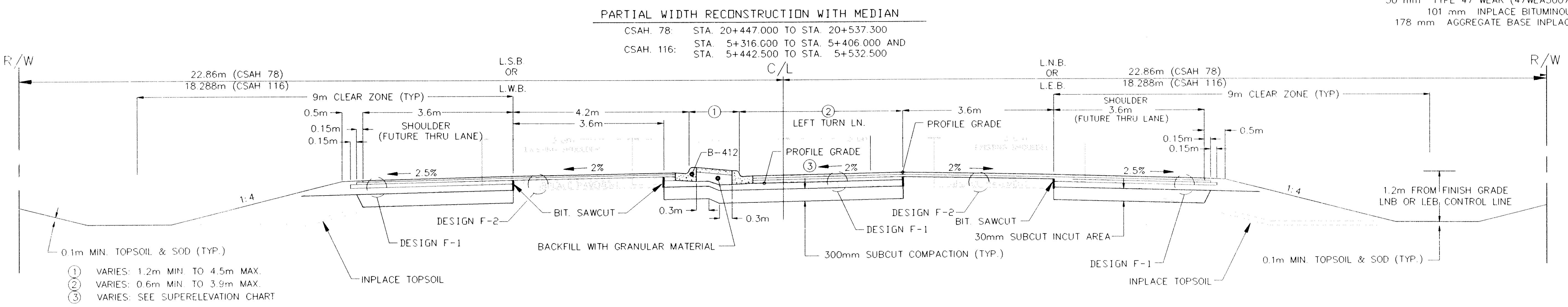
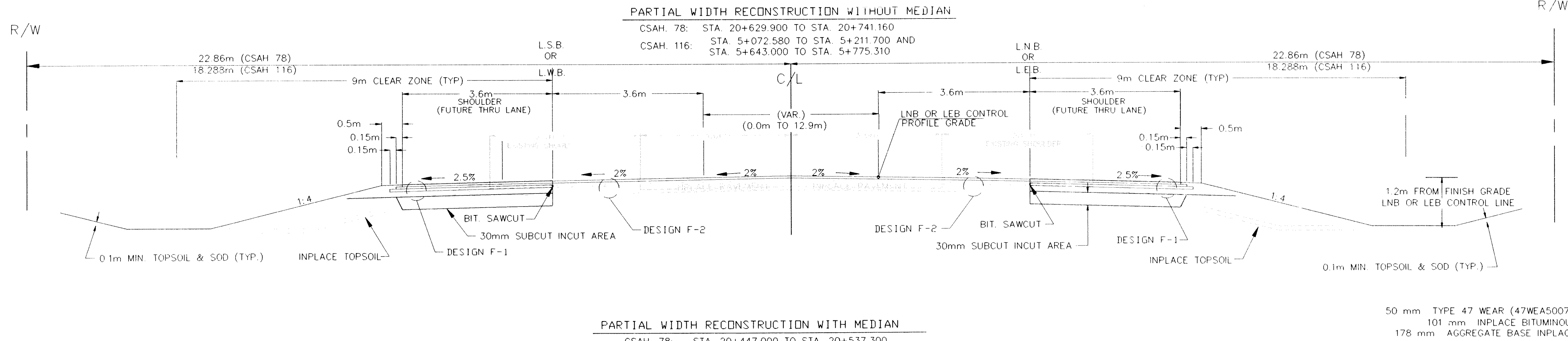

NO	DATE	BY	CKD	APPR	REVISION

NAME: typ-sh.dwg 6398 33005

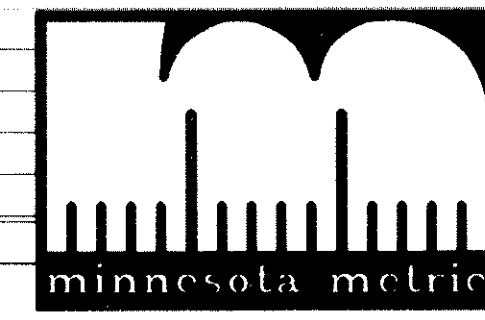

I HEREBY CERTIFY THAT THIS PLAN WAS PREPARED BY ME OR UNDER MY DIRECT SUPERVISION AND THAT I AM A DULY REGISTERED PROFESSIONAL ENGINEER UNDER THE LAWS OF THE STATE OF MINNESOTA.

DATE _____ REG. NO. _____

DRAWN BY: MN DATE 04/27/98
 DESIGN BY: DWF DATE 04/27/98
 CHECKED BY: DWF DATE 04/27/98

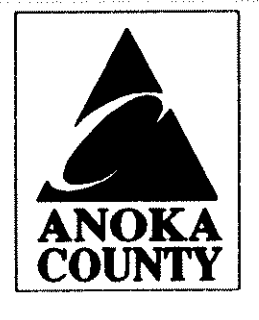

**ANOKA COUNTY
 HIGHWAY DEPT.**

STATE PROJECT NO. 02-678-12/02-716-02
 STATE AID PROJECT NO. _____
 STATE AID PROJECT NO. _____
 COUNTY PROJECT NO. _____

**TYPICAL SECTIONS
 INTERSECTION
 C.S.A.H. 78 AND C.S.A.H. 116**

Sheet 9 of 59 Sheets

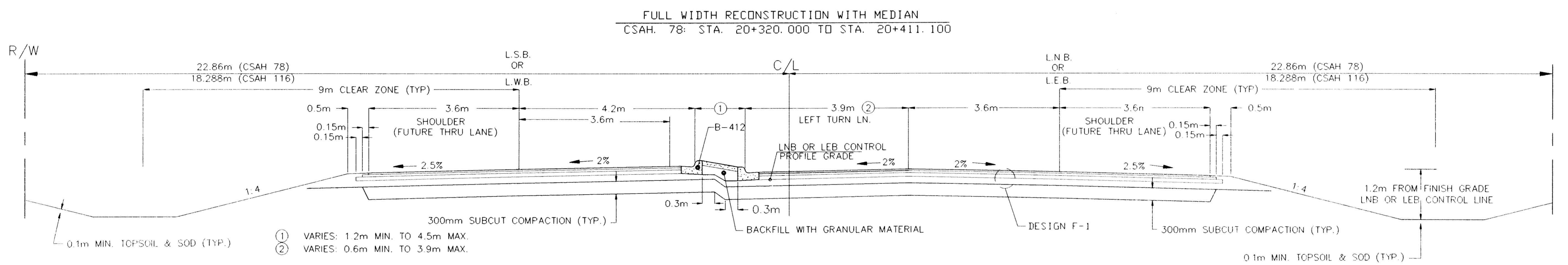
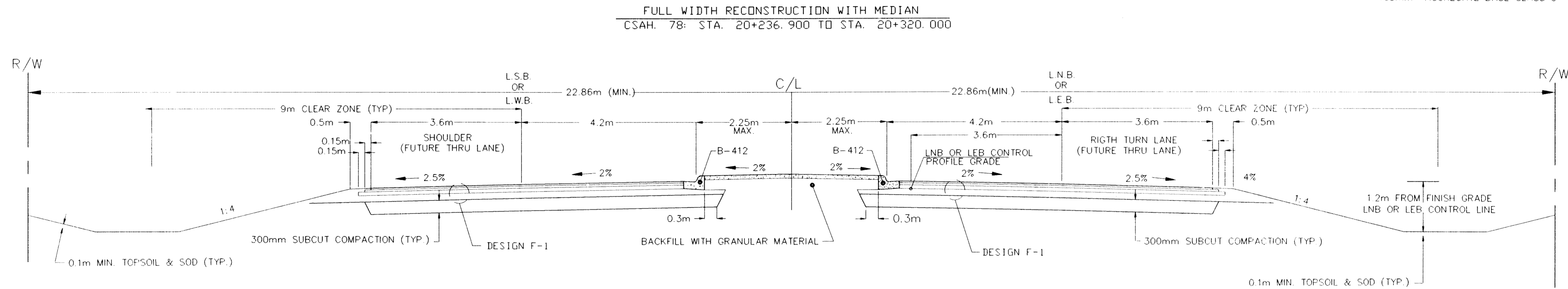
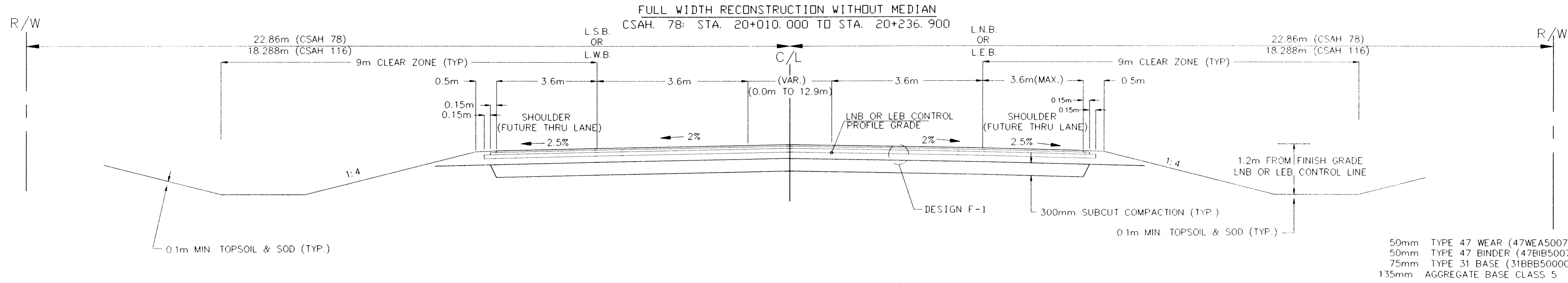

NO	DATE	BY	CKD	APPR	REVISION

NAME: typ-shdwg 6398 33005



I HEREBY CERTIFY THAT THIS PLAN WAS PREPARED BY ME OR UNDER MY DIRECT SUPERVISION AND THAT I AM A DULY REGISTERED PROFESSIONAL ENGINEER UNDER THE LAWS OF THE STATE OF MINNESOTA.

DRAWN BY: MN DATE 04/27/98

DESIGN BY: DWF DATE 04/27/98

CHECKED BY: DWF DATE 04/27/98



**ANOKA COUNTY
HIGHWAY DEPT.**

STATE PROJECT NO. 02-678-12/02-716-02

STATE AID PROJECT NO. _____

STATE AID PROJECT NO. _____

COUNTY PROJECT NO. _____

TYPICAL SECTIONS

INTERSECTION
C.S.A.H. 78 AND C.S.A.H. 116

Sheet 8 of 59 Sheets

EARTHWORK SUMMARY



EXCAVATION

COMMON EXCAVATION . . . 13042m ³	}	REGULAR 5849 m ³ ①	{	(#78) 3762 m ³
				(#116) 2087 m ³
		SUBCUT 5360 m ³	{	(#78) 3021 m ³
				(#116) 2339 m ³
		TOPSOIL 1833 m ³	{	(#78) 916 m ³
				(#116) 917 m ³

EMBANKMENT (CV)

GRANULAR 3494 m ³	{	(#78) 2448 m ³
		(#116) 1046 m ³
SUBCUT 5360 m ³	{	(#78) 3021 m ³
		(#116) 2339 m ³
TOPSOIL 1932 m ³	{	(#78) 1066 m ³
		(#116) 866 m ³

BALANCE

TOPSOIL
 TOPSOIL DRESSING (CV) - [TOPSOIL STRIPPING (EV) x SHRINKAGE FACTOR] = EXCESS(-) OR SHORTAGE(+)
 (CSAH 78) 1066 - (916 x 0.80) = 333m³ SHORTAGE (CV), (SEE NOTE 22.)
 (CSAH 116) 866 - (917 x 0.80) = 132 m³ SHORTAGE (CV), (SEE NOTE 22.)
 TOPSOIL BORROW
 SHORTAGE x SWELL FACTOR = BORROW (LV)
 (333 + 132) x 1.3 = 605 m³ (LV)

GRANULAR MATERIAL

GRANULAR (CV) + SUBCUT - [REGULAR EXCAVATION (EV) x SHRINKAGE FACTOR] - [SUBCUT+SUBGRADE EXCAVATION x SHRINKAGE FACTOR] = EXCESS(-) OR SHORTAGE(+)
 (CSAH 78) 2448 + 3021 - [(3762-1070) x 0.80] - (3021 x 0.85) = 748 m³ SHORTAGE (CV)
 (CSAH 116) 1821 + 2339 - [(2087 - 414) x 0.80] - (2339 x 0.85) = 833 m³ SHORTAGE (CV)
 TOTAL 1581 m³
 SHORTAGE x SWELL FACTOR = BORROW (LV)
 (CSAH 78) 748 x 1.20 = 898 m³ BORROW (LV)
 (CSAH 116) 833 x 1.20 = 1000 m³ BORROW (LV)
 TOTAL 1898 m³

① INCLUDES 1484 m³ (1070m³ + 417m³) BITUMINOUS REMOVAL.
 BITUMINOUS PAVEMENT REMOVALS WILL BE PAID UNDER ITEM 2104.

SOIL FACTORS:
 (1) REGULAR GRADING AND TOPSOIL DRESSING (EV TO CV): 80% SHRINKAGE
 (2) SUBCUT COMPACTION (EV TO CV): 90% SHRINKAGE
 (3) SELECT GRANULAR BORROW (CV TO LV): 120% SWELL
 (4) TOPSOIL BORROW (CV TO LV): 130% SWELL

SOILS AND CONSTRUCTION NOTES:

1. TOP OF GRADING GRADE IS DEFINED AS THE BOTTOM OF THE AGGREGATE BASE.
2. IN FILL AREAS, THE SUBGRADE SHALL BE CONSTRUCTED WITH SELECTED GRADING MATERIAL.
3. SELECTED GRADING MATERIALS SHALL CONSIST OF GRANULAR MATERIALS.
4. GRANULAR MATERIAL, REGARDLESS OF SOURCE, SHALL MEET THE REQUIREMENTS OF SPEC. 3149.2B.
5. COMPACTION OF THE GRADING PORTION OF THIS PROJECT SHALL BE BY THE "SPECIFIED DENSITY METHOD".
6. TEST ROLLING WILL NOT BE REQUIRED.
7. BITUMINOUS OR CONCRETE ITEMS REMOVED BY CONSTRUCTION SHALL BECOME THE PROPERTY OF THE CONTRACTOR AND SHALL BE EITHER RECYCLED OR DISPOSED OF IN ACCORDANCE WITH THE REQUIREMENTS OF 2104.3C3 WITH NO DIRECT COMPENSATION MADE THEREFORE.
8. DISPOSITION OF EXCESS EXCAVATED MATERIAL SHALL BE IN ACCORDANCE WITH THE REQUIREMENTS OF 2105.3D WITH NO DIRECT COMPENSATION THEREFORE.
9. WHERE MATCHING INTO THE INPLACE ROADWAY AT THE ENDS OF CONSTRUCTION, CUT VERTICALLY TO THE TOP OF THE GRADING GRADE, AND THEN AT A 20:1 TAPER TO THE BOTTOM OF THE RECOMMENDED SUBGRADE EXCAVATION.
10. WHERE CONNECTING NEW SURFACING TO AN INPLACE PAVEMENT, THE EXCAVATION SHALL BE BACKFILLED PROMPTLY TO AVOID UNDERMINING THE INPLACE PAVEMENT.
11. USE TACK COAT BETWEEN ALL BITUMINOUS MIXTURES PRIOR TO PLACING BITUMINOUS MIXTURES AND PRIOR TO PLACING ANY BITUMINOUS MIXTURES ON EXISTING CONCRETE OR BITUMINOUS SURFACES. THE BITUMINOUS TACK COAT MATERIAL SHALL BE APPLIED AT UNIFORM RATE OF 0.23 L/m² BETWEEN BITUMINOUS LAYERS. THE APPLICATION RATES ARE FOR UNDILUTED EMULSION (AS SUPPLIED FROM THE REFINERY); ASPHALT EMULSION MAY BE FURTHER DILUTED IN THE FIELD IN ACCORDANCE WITH SPEC. 2357.
12. COMPACTION OF ALL OF THE BITUMINOUS COURSES SHALL BE BY THE "MODIFIED SPECIFIED DENSITY METHOD".
13. COMPACTION OF THE AGGREGATE BASE LAYERS SHALL BE BY THE "SPECIFIED DENSITY METHOD", UNLESS RECYCLED MATERIAL'S.
14. PLACE MINIMUM 100mm TOPSOIL OR SLOPE DRESSING ON ALL AREAS DISTURBED BY CONSTRUCTION AND SCHEDULED FOR PERMANENT TURF ESTABLISHMENT. TOPSOIL BORROW TO BE UTILIZED IN AREAS TO BE SODDED. FERTILIZE WITH COMMERCIAL FERTILIZER, ANALYSIS 10-10-10 (OR EQUIVALENT), AT A RATE OF 560 kg PER ha.
15. USE MIXTURE 70A SEED AND TYPE 1 MULCH IN AREAS TO BE SEEDED.
16. SOD ALL MAINTAINED LAWNS DISTURBED BY CONSTRUCTION.
17. ALL SOD UTILIZED WITHIN THE PROJECT LIMITS SHALL MEET THE REQUIREMENTS OF SPEC. 3878.2A (LAWN SOD).
18. ORGANIC AND NONGRANULAR EXCAVATED MATERIAL MAY BE USED IN EMBANKMENT CONSTRUCTION IN AREAS OUTSIDE OF A 1 1/2:1 SLOPE FROM THE BACK OF CURB, OR GRADING P.I.
19. BITUMINOUS REMOVAL QUANTITY BASED ON SQUARE METER REMOVED. IN PLACE SURFACE ASSUMED TO BE 100mm IN DEPTH. CONTRACTOR SHALL INVESTIGATE AND MAKE OWN DETERMINATION OF ACTUAL PAVEMENT DEPTH.
20. ALL SILT FENCING AS SHOWN IN THE PLANS SHALL BE IN PLACE PRIOR TO THE COMMENCEMENT OF GRADING OPERATIONS.
21. A DOUBLE ROW OF BALE CHECKS SHALL BE INSTALLED ALONG DITCH RUNS FOR EROSION CONTROL AS DIRECTED BY THE ENGINEER.
22. TOPSOIL STRIPPINGS TO BE SALVAGED AND UTILIZED TO ITS FULLEST EXTENT WITHIN THE PROJECT LIMITS.

BASE AND BITUMINOUS QUANTITIES CHART

STATION - STATION	LOCATION	DESCRIPTION	BIT. SURFACE CONSTRUCTION m ²	BITUMINOUS			TACK COAT LITERS	AGGREGATE		
				50mm WEAR TON	50mm BINDER TON	75mm BASE TON		BASE CL-5A m ²	m ³	
CSAH 116										
5+066.32	5+398.50	LT	SHOULDER	1163.73	163.73	157.75	246.34	535.29	1667.64	216.89
5+072.58	5+400.00	RT	MAIN	1197.85	140.75	162.10	252.71	551.01	1643.75	221.50
5+072.58	5+205.00	LT	OVERLAY	608.50	71.5			139.96		
5+261.62	5+414.00	RT	MAIN & SHOULDER	1497.20	175.92	194.64	291.95	688.71	1614.39	242.16
5+261.62	5+414.00	RT	MAIN	1101.20	129.39	143.16	214.73	506.55	1101.20	165.18
5+261.62	5+414.00	LT	LT TURN LANE	546.90	64.26	71.10	106.65	251.57	835.78	125.37
5+261.62	5+414.00	RT	RT TURN LANE	631.80	74.24	73.77	123.20	290.63	748.82	112.32
5+436.00	5+615.00	LT & RT	MEDIAN	569.10	66.87	73.98	110.97	261.79		105.61
5+424.20	5+775.31	LT	OVERLAY	821.90	96.57			189.04		
5+424.20	5+775.31	RT	OVERLAY	820.90	96.46			188.81		
5+448.60	5+775.50	LT	SHOULDER	1219.00	143.23	164.83	256.78	560.74	1641.04	223.41
5+450.00	5+775.50	RT	SHOULDER	1171.30	137.63	158.63	247.47	538.80	1634.01	216.72
5+440.00	5+615.00	LT	OVERLAY	609.20	71.58			140.12		
5+615.00	5+775.50	RT	OVERLAY	609.20	71.58			140.12		
SUB TOTAL				9597.70	1127.73	880.11	1351.76	3756.87		1190.76
CSAH 78										
20+010.00	20+237.00	LT	MAIN & SHOULDER	1753.00	205.98	232.66	356.14	806.38		280.68
20+010.00	20+237.00	RT	MAIN & SHOULDER	1721.90	202.32	231.52	358.78	792.07		311.12
20+237.00	20+422.66	RT	MAIN & SHOULDER	1447.30	170.06	191.78	293.10	665.76		228.78
20+237.00	20+422.66	LT	MAIN & SHOULDER	1506.95	177.07	199.53	304.74	693.20		236.83
20+237.00	20+422.66	LT	LT TN LN	487.20	57.25	63.34	95.00	224.11		80.51
20+440.00	20+635.00	LT & RT	MEDIAN	561.00	65.92	72.93	109.40	258.06		104.52
20+435.45	20+635.00	LT	OVERLAY	730.30	85.81			167.97		
20+435.45	20+635.00	RT	OVERLAY	730.80	85.87			168.08		
20+453.50	20+741.16	RT	SHOULDER	1228.10	144.30	165.44	256.85	564.93	1488.43	219.25
20+453.50	20+741.16	LT	SHOULDER	1208.00	141.94	162.73	252.64	555.68	1481.90	215.64
20+635.00	20+741.16	LT	OVERLAY	608.40	71.49			139.93		
20+635.00	20+741.16	RT	OVERLAY	384.30	45.16			88.39		
SUB TOTAL				12367.25	1453.15	1319.93	2026.66	5124.56		1677.33
TOTAL				21964.95	2580.88	2200.04	3378.42	8881.43		2868.09

TABULATION CHARTS

EARTHWORK SUMMARY, CONSTRUCTION NOTES
 BASE AND BITUMINOUS QUANTITIES CHART

1	6/15/99	KLD	LAR		Items with bold italics and strikethroughs show the change of the west leg of CSAH 116 from rural to urban section.
NO	DATE	BY	CKD	APPR	REVISION
NAME: 02Est-Quon.dwg	5-27-99	4:41:13 pm	EST		



I HEREBY CERTIFY THAT THIS PLAN WAS PREPARED BY ME OR UNDER MY DIRECT SUPERVISION AND THAT I AM A DULY REGISTERED PROFESSIONAL ENGINEER UNDER THE LAWS OF THE STATE OF MINNESOTA.
 DATE _____ REG. NO. _____

DRAWN BY: MN DATE 04/27/98
 DESIGN BY: DWF DATE 04/27/98
 CHECKED BY: DWF DATE 04/27/98



ANOKA COUNTY
 HIGHWAY DEPT.

STATE PROJECT NO. 02-678-12 / 02-716-02
 STATE AID PROJECT NO. _____
 STATE AID PROJECT NO. _____
 COUNTY PROJECT NO. _____

TABULATION CHARTS

CONSTRUCTION BIT FLUME (K)			
STATION	DESCRIPTION	CSAH 78 m ²	CSAH 116 m ²
5+610.93	12.5m LT LEB		4.5
5+284.75	7.5m LT LEB		4.5
20+728.75	8.3m LT LNB	4.5	
SUB TOTAL		4.5	4.5
TOTAL		9.0	

* GUARDRAIL CONSTRUCTION (L) CSAH 78			
STATION - STATION	LOCATION	REMARKS	METER
20+143.400 - 20+173.600	6.40 LT LSB		7.80
TOTAL			7.80

CONCRETE CURB AND GUTTER (M) CSAH 78 CSAH 116				
STATION	LOC.	DESCRIPTION	m	m
5+261.62	5+406.00	LT. & RT. DESIGN B412 (PLATE NO. M7100G)		288.80
5+261.62	5+398.44	LT. & RT. DESIGN B418 (PLATE NO. M7100G)		273.60**
5+442.50	5+635.50	LT. & RT. DESIGN B412 (PLATE NO. M7100G)		391.50
20+236.90	20+411.10	LT. & RT. DESIGN B412 (PLATE NO. M7100G)	348.20	
20+447.30	20+629.90	LT. & RT. DESIGN B412 (PLATE NO. M7100G)	369.10	
SUB TOTAL			717.30	953.9
TOTAL			1671.20	

** B418 C&G USED ON OUTSIDE CURB, B412 USED ON MEDIANS

CONSTRUCTION CONCRETE WALK (N)					
STATION TO STATION	LOC.	DESCRIPTION	100mm m ²	150mm m ²	
5+211.70 - 5+213.20	LT. LEB	MEDIAN NOSE		2.45	
5+261.62 - 5+404.50	LT. LEB	MEDIAN	139.00		
5+404.50 - 5+406.00	LT. LEB	MEDIAN NOSE		1.80	
5+442.50 - 5+444.50	LT. LEB	MEDIAN NOSE		1.80	
5+444.50 - 5+635.00	LT. LEB	MEDIAN	362.60		
5+635.00 - 5+636.50	LT. LEB	MEDIAN NOSE		2.45	
SUB TOTAL (CSAH 116)			465.60	6.05	
20+236.90 - 20+238.40	LT. LNB	MEDIAN NOSE		2.45	
20+238.40 - 20+409.60	LT. LNB	MEDIAN	276.40		
20+409.60 - 20+411.10	LT. LNB	MEDIAN NOSE		1.80	
20+447.30 - 20+448.80	LT. LNB	MEDIAN NOSE		1.80	
20+448.80 - 20+628.40	LT. LNB	MEDIAN	322.00		
20+628.40 - 20+629.90	LT. LNB	MEDIAN NOSE		2.45	
SUB TOTAL (CSAH 78)			598.40	8.50	
TOTAL			1064.00	14.55	

CONSTRUCTION BITUMINOUS CURB (O) CSAH 78 CSAH 116				
STATION - STATION	LOCATION	REMARKS	m	m
5+261.62 - 5+400	4.20m RT LEB			134.00
5+531.75 - 5+610.30	4.20m LT LWB			83.40
20+728.40 - 20+741.16	7.80m LT LNB		12.50	
SUB TOTAL			12.50	217.40
TOTAL			229.90	

BERM CONSTRUCTION LOCATION (P) CSAH 78 CSAH 116				
STATION - STATION	LOCATION	REMARKS	EACH	EACH
5+285.53 - 5+311.35	29.73m LT LEB			1
5+531.74 - 5+610.30	12.80m LT LEB			1
20+729.32 - 20+749.05	7.95m LT LNB		1	2
SUB TOTAL			1	2
TOTAL			3	

MILL BITUMINOUS SURFACE (Q) CSAH 78 CSAH 116				
STATION	LOCATION	REMARKS	m ²	m ²
5+072.580 - 5+090.00	LT & RT LEB			131.37
5+750.00 - 5+775.310	LT & RT LNB			193.43
20+680.00 - 20+741.160	LT & RT LNB		525.20	
SUB TOTAL			525.20	193.43
TOTAL			718.63	

SANITARY SEWER MODIFICATIONS (R) CSAH 116 ADJUST EACH				
STATION	LOCATION	INPLACE	REMARKS	EACH
5+742.60	11.60 LT LEB	MANHOLE		1
5+714.80	11.70 LT LEB	MANHOLE		1
TOTAL				2

CULVERT TABULATION (T)													
STATION	LOC	INPLACE	REMARKS	INLET	OUTLET	GRADE	F. & I. CULVERT				F. & I. FIBER BLANKET		
							SALVAGE CULV. PIPE		INSTALL CULV. PIPE			REMOVE RIPRAP	
							m	APR.	m	APR.		m ³	m ³
5+224.500	8.06 LT LWB	375mm CMP		272.065	272.028	-0.3							
5+383.100	8.12 LT LWB	375mm CMP	U.P.A. DRIVEWAY	272.386	272.349	-0.3							
5+585.000	5.50 RT LEB	375mm CMP	#1530 DRIVEWAY				11.0	2					
5+675.580	7.51 RT LEB	375mm CMP	NEW HWY DRIVEWAY	272.536	272.457	+0.3		2					
5+675.580	8.10 LT LWB	375mm CMP	DAY CARE DRIVEWAY	272.100	271.634	-1.9		1					
20+583.800	21.30 LT LNB	600mm RC APRON	CROSS CSAH 78					1		4.5			
20+583.800	10.08 RT LNB	600mm RC APRON	CROSS CSAH 78					1					
SUB TOTAL							11.0	4		2		16	
SUB TOTAL								2		2			
TOTAL							11.0	6		4	4.5		16

DRAINAGE CASTING SCHEDULE (S)					
ASS'Y TYPE	NO REQ'D	FRAME CASTING	GRATE CASTING	CURB BOX CASTING	
CSAH 116 A	9	801	810	821-B	
CSAH 78 A	10	801	810	821-B	
TOTAL		19			

STORM SEWER TABULATION (U)										FURNISH & INSTALL															
STRUCT.	STATION	LOC	REMARKS	MH/CB	STRUCTURE DESIGN	PAY HT. m	TOP OF CASTING ELEVATION	OUTLET ELEVATION	ADJUST INPL. CB. EACH	CASTING ASSEMBLY	300mmRCP				450mmRCP				APRON EACH	DRAINS TO	GRADE %	RIPRAP m ³	FIBER BLANKET m ²		
											300mmRCP	375mmRCP	450mmRCP	600mmRCP	300mmRCP	375mmRCP	450mmRCP	600mmRCP							
1	20+239.80	4.977 LT LNB		CB	H	1.0	274.069	272.980		A	2.7														
2	20+239.80	7.670 LT LNB		CB	G	1.0	274.043	272.967		A	11.2														
3	20+239.80	9.326 RT LNB		OUTLET	OUTLET			272.911																	
4	20+321.50	7.150 LT LNB		CB	G	1.3	273.548	272.737		A	14.8														
5	20+321.50	10.738 RT LNB		OUTLET	OUTLET			272.589																	
6	20+390.00	9.043 LT LNB		CB	H	1.0	273.473	272.362		A	1.9														
7	20+390.00	7.157 LT LNB		CB	G	1.0	273.396	272.356		A	13.5														
8	20+390.00	9.432 RT LNB		OUTLET	OUTLET			272.316																	
9	20+537.30	5.743 LT LNB		CB	H	1.0	271.684	270.599		A	1.9														
10	20+537.30	3.854 LT LNB		CB	G	1.1	271.762	270.594		A	12.3														
11	20+541.00	8.532 RT LNB		OUTLET	OUTLET			270.557																	
12	20+583.80	21.300 LT LNB	INSTALL EXIST. 600mm APRON	INLET	INLET			270.015																	
13	20+583.80	8.839 LT LNB	2 PIPE CONNECT	CB	F	1.8	271.447	269.565		A															
14	20+583.80	3.857 LT LNB	2 PIPE CONNECT	CB	F	2.0	271.453	269.431		A															
15	20+583.80	10.084 RT LNB	INSTALL EXIST. 600mm APRON	OUTLET	OUTLET			269.013																	
SUB TOTAL (CSAH 78)							11.2			9	58.3														
21	5+265.00	3.857 LT LEB		CB	H	1.0	273.166	272.080		A	5.2														
22	5+265.00	8.049 LT LEB		CB	G	1.0	273.163	272.054		A	9.3														
23	5+342.92	13.270 LT LWB		INLET	INLET			272.000																	
24	5+342.92	5.670 LT LWB		CB	G	1.1	273.067	271.889		A	5.8														
25	5+336.31	7.185 LT LEB		CB	F	1.3	273.189	271.835		A			13.4												
26	5+328.6	7.455 RT LEB		CB	G	1.2	272.995	271.773		A			15.5												
27	5+445.00	5.743 LT LEB		CB	H	1.1	273.520	272.429		A	1.9														
28	5+445.00	3.857 LT LEB		CB	G	1.1	273.598	272.414		A	10.5														
29	5+445.00	9.732 LT LEB		OUTLET	OUTLET			272.340																	
30	5+532.50	5.743 LT LEB		CB	H	1.0	273.503	272.512		A	1.9														
31	5+532.50	3.857 LT LEB		CB	G	1.0	273.581	272.497		A	9.3														
32	5+532.50	8.532 LT LEB		OUTLET	OUTLET			272.423																	
33	5+633.50	6.528 LT LEB		CB	H	0.9	273.430	272.484		A	2.7														
34	5+633.50	3.857 LT LEB		CB	H	0.9	273.422	272.475		A	8.5														
35	5+633.50	7.732 LT LEB		OUTLET	OUTLET			272.450																	
SUB TOTAL (CSAH 116)							9.6			9	40.6														
TOTAL							20.8			1	18	98.9	28.9	67.9	5.0	4	10						0	24	

CSAH 78	LOC.	REMARKS	CSAH 116
3.0 m	H	6.9	3.9 m
3.8 m	F	5.1	1.3 m
4.4 m	G	8.8	4.4 m

① INSTALL SALVAGED APRON

MAILBOX RELOCATION (X)	
NAME	ADDRESS
Children's World	1485 Bunker Lake
Anoka Co. Sheriff Dept.	1530 Bunker Lake
Andover Wheel & Frame	13476 Hanson Blvd
Roger's Auto Body	13530 Hanson Blvd
Beberg's Nursery	13540

REMOVE BITUMINOUS PAVEMENT (A)		
STATION TO STATION	DESCRIPTION	m ²
CSAH 116		
5+261.62 - 5+416.90	LT SHOULDER	522.00
5+261.62 - 5+416.90	RT SHOULDER	514.60
5+261.62 - 5+416.90	MAIN ROAD (MEDIAN)	1118.2
5+436.00 - 5+775.31	LT SHOULDER	453.20
5+436.00 - 5+775.31	RT SHOULDER	271.60
5+536.00 - 5+643.00	MAIN ROAD (MEDIAN)	1132.30
SUB TOTAL		4011.90
CSAH 78		
20+010.00 - 20+422.60	MAIN ROAD	2970.60
20+010.00 - 20+422.60	LT SHOULDER	1456.00
20+010.00 - 20+422.60	RT SHOULDER	1452.10
20+440.00 - 20+635.00	MAIN ROAD (MEDIAN)	1072.10
20+435.45 - 20+741.16	LT SHOULDER	476.10
20+435.45 - 20+741.16	RT SHOULDER	584.20
SUB TOTAL		8011.10
TOTAL		12023.00

SAWING BITUMINOUS PAVEMENT (B)		
STATION TO STATION	DESCRIPTION	m
CSAH 116		
5+434.50 - 5+775.31	LT EDGE OF MAT	340.81
5+377.60 - 5+775.31	RT EDGE OF MAT	397.71
5+205.00 - 5+412.00	LT L.E.B.	207.00
5+205.00 - 5+412.00	RT L.W.B.	207.00
5+311.50 - 5+320.60	RT ENT.	9.20
5+205.00	LT L.W.B. RT L.E.B.	5.70
5+416.90	LT L.W.B. RT L.E.B.	32.56
5+436.00 - 5+664.30	LT L.E.B.	228.30
5+436.00 - 5+664.30	RT L.W.B.	228.30
5+436.00	LT L.W.B. RT L.E.B.	5.70
5+664.30	LT L.W.B. RT L.E.B.	5.70
5+521.80 - 5+531.74	LT ENT.	10.10
5+569.30 - 5+581.30	RT ENT.	12.60
5+672.00 - 5+681.00	LT ENT.	9.00
5+711.40 - 5+737.70	RT ENT.	26.30
5+775.31	LT L.W.B. RT L.E.B.	14.00
SUB TOTAL		1320.28
CSAH 78		
20+010.00	LT L.S.B. RT L.N.B.	14.30
20+054.39 - 20+062.39	LT ENT.	8.00
20+177.44 - 20+185.36	RT ENT.	7.92
20+264.95 - 20+275.0	LT ENT.	10.05
20+342.10 - 20+350.00	LT ENT.	7.90
20+422.00	LT L.S.B. RT L.N.B.	47.00
20+440.00	LT L.S.B. RT L.N.B.	6.00
20+440.00 - 20+635.00	LT L.N.B.	195.00
20+440.00 - 20+635.00	RT L.S.B.	195.00
20+635.00	LT L.N.B. RT L.S.B.	6.00
20+435.00 - 20+742.22	LT L.S.B.	307.22
20+435.00 - 20+742.22	RT L.N.B.	307.22
20+511.20 - 20+518.26	RT ENT.	7.06
20+435.00 - 20+742.22	RT ENT.	7.05
SUB TOTAL		1125.72
TOTAL		2446.00

CONCRETE CURB REMOVAL (C)		
STATION	DESCRIPTION	m
CSAH 116		
5+521.750	WEST SUPER AMERICA ENT	2.20
5+531.750	EAST SUPER AMERICA ENT	1.60
SUB TOTAL		3.80
CSAH 78		
20+510.200	SOUTH SUPER AMERICA ENT	5.60
20+519.200	NORTH SUPER AMERICA ENT	5.60
SUB TOTAL		11.20
TOTAL		15.00

FLUME REMOVAL (D)		
STATION	DESCRIPTION	m
CSAH 78		
20+171 - 20+174	3.5m RT LNB SOUTH OF A.C.H.D. ENT.	3
TOTAL		3

DRIVEWAY BITUMINOUS REMOVAL AND CONSTRUCTION (E)										
DESCRIPTION			REMOVAL				REPLACEMENT			
STATION	ADDRESS	LOC.	LENGTH m	WIDTH m	GRAVEL m ²	BIT m ²	LENGTH m	WIDTH m	GRAVEL m ²	BIT m ²
CSAH 116										
5+078.50		LT.	7.79	11.68						
5+224.50		LT.	11.80	6.20	108.40		9.00	6.20	70.30	
5+316.00	SPUR ENT.	RT.	14.90	9.20		181.10	7.50	9.20		99.2
5+334.00	U.P.A. ENT.	LT.	14.90	7.50	152.30		10.40	7.50	89.4	
5+382.94	U.P.A. ENT.	LT.					10.50	7.50	86.8	
5+396.30	NON CONST. REQ.	LT.	10.40	10.00	148.30					
5+527.00	SUPER AMERICA ENT.	RT.	10.20	10.00		142.80	7.20	10.00		88.90
5+582.00		RT.	41.30	7.40		350.50				
5+675.60	DAY CARE ENT.	RT.	6.90	8.62		93.40	5.20	8.60		57.20
5+675.60	HWY. ENT.	RT.					42.10	10.00		518.30
5+718.00		RT.	52.50	7.00		590.20				
5+579.50 TO 5+709.50	NEW SHERIFF ENT.	RT.					130.00	7.20		1249.50
SUB TOTAL					300.60	1358.00			89.40	2013.10
CSAH 78										
20+058.00		LT.	15.00	8.10		141.20	7.10	8.00		148.40
20+173.60		LT.	7.40	8.20		112.30				
20+181.00	HWY. ENT.	RT.	24.20	8.40		279.30	16.70	8.40		233.60
20+272.00		LT.	7.88	9.20		79.30	12.80	9.20		139.30
20+346.00		LT.	12.10	8.20		158.20	12.80	8.20		120.20
20+515.10		RT.	14.20	9.00		181.00	11.30	9.00		123.90
20+644.60		RT.	11.70	9.00		100.70	10.10	8.80		110.40
SUB TOTAL						1052.00				875.80
TOTAL					300.60	2410.00			89.40	2888.90

CLEARING AND GRUBBING (F)						
STATION	LOCATION	CLEARING		GRUBBING		
		TREE	ha	TREE	ha	
CSAH 116						
5+266.46	13.24 LT LWB	1		1		
5+270.03	13.64 LT LWB	1		1		
5+287.83	14.98 LT LWB	1		1		
5+291.35	14.73 LT LWB	1		1		
5+294.86	14.95 LT LWB	1		1		
5+304.47	14.92 LT LWB	1		1		
5+310.91	14.78 LT LWB	1		1		
5+314.28	14.42 LT LWB	1		1		
5+317.19	14.21 LT LWB	1		1		
5+321.41	14.46 LT LWB	1		1		
5+447.59 TO 5+503.81	11.09-11.50 RT LEB		0.04		0.04	
5+514.11	18.06 RT LEB	1		1		
5+515.56	19.51 RT LEB	1		1		
5+548.88 TO 5+658.00	15.71-18.79 RT LEB		0.02		0.02	
1+015.20 TO 1+087.80	10.80m LT & RT C/L ENT		0.12		0.12	
SUB TOTAL		12	0.18	12	0.18	
CSAH 78						
20+044.81 TO 20+171.69	13.05-18.66 RT LNB		0.08		0.08	
20+200.09 TO 20+228.30	7.44- 5.73 LT LNB		0.06		0.06	
20+275.16	0.52 RT LNB	1		1		
20+348.38 TO 20+410.54	14.03-16.38 RT LNB		0.02		0.02	
20+401.21	12.24 RT LNB	2		2		
20+403.95	15.42 RT LNB	1		1		
20+408.40	12.58 RT LNB	1		1		
20+408.63	16.14 RT LNB	1		1		
20+657.75 TO 20+744.16	15.51-26.55 RT LNB		0.06		0.06	
20+629.89	24.72 LT LNB	1		1		
20+616.62	23.72 LT LNB	1		1		
20+609.31	24.27 LT LNB	1		1		
20+595.22	23.82 LT LNB	1		1		
20+588.36	23.93 LT LNB	1		1		
20+549.33	24.38 LT LNB	1		1		
20+532.13	23.81 LT LNB	1		1		
20+528.41	24.38 LT LNB	1		1		
20+519.87	24.26 LT LNB	1		1		
20+515.59	24.04 LT LNB	1		1		
20+339.51	44.83 LT LNB	1		1		
20+035.78	29.27 LT LNB	1		1		
TOTAL		18	0.22	18	0.22	
		30	0.40	30	0.40	

TABULATION CHARTS

- REMOVE BITUMINOUS PAVEMENT
- SAWING BITUMINOUS PAVEMENT
- FLUME REMOVAL
- DRIVEWAY BITUMINOUS REMOVAL AND CONSTRUCTION
- CLEARING AND GRUBBING
- RELOCATE HYDRANT AND VALVE
- ADJUST VALVE BOX-WATER
- TURF ESTABLISHMENT

ADJUST VALVE BOX-WATER (H)				
STATION	LOC.	REMARKS	NO.	
CSAH 116				
5+476.80	2.94 LT LWB		1	
5+623.20	3.60 LT LWB		1	
5+674.60	5.10 LT LEB		1	
5+677.90	5.10 LT LEB		1	
5+744.80	3.20 LT LEB		1	
SUB TOTAL			5	
CSAH 78				
20+449.40	11.00 RT LNB		1	
20+530.20	6.10 RT LNB		1	
20+671.50	6.50 RT LNB		1	
20+671.50	11.00 RT LNB		1	
SUB TOTAL			4	
TOTAL			9	

TURF ESTABLISHMENT (I)					
STA. TO STA.	LOCATION	SOD m ²	SEEDING ha	SEED kg	FERTILIZER kg
CSAH 116					
5+261.6 - 5+311.5	RT		0.06	3.0	33.6
5+082.2 - 5+221.4	LT		0.1	5	56
5+261.6 - 5+329.7	LT		0.08	4.0	44.8
5+320.7 - 5+418.5	RT	588			
5+337.2 - 5+413.4	LT		0.09	4.5	50.4
5+433.6 - 5+521.8	LT	822			
5+448.0 - 5+578.2	RT		0.10	5.0	56.0
5+531.8 - 5+670.9	LT	1360			
5+587.0 - 5+724.8	RT		0.10	5.0	56.0
5+680.4 - 5+724.8	RT		0.10	5.0	56.0
5+682.6 - 5+775.3	LT		0.10	5.0	56.0
5+732.5 - 5+775.3	RT		0.10	5.0	56.0
SUB TOTAL		2770	0.73	36.5	408.8
CSAH 78					
20+003.4 - 20+054.5	LT	498			
20+003.4 - 20+177.2	RT		0.20	10.0	112.0
20+062.4 - 20+168.8	LT		0.10	5.0	56.0
20+177.0 - 20+264.4	LT		0.10	5.0	56.0
20+185.3 - 20+398.3	RT		0.20	10.0	56.0
20+273.8 - 20+349.9	LT	582			
20+330.7 - 20+405.3	LT	652			
20+454.3 - 20+750.0	LT		0.20	10.0	112.0
20+451.8 - 20+510.1	RT	566			
20+519.2 - 20+639.9	RT	1145			
20+648.9 - 20+750.0	RT		0.10	5.0	56.0
SUB TOTAL		3443	0.90	45.0	504.0
TOTAL		6213	1.63	81.5	912.8

SILT FENCE LOCATION (J)		
STA. TO STA.	DESCRIPTION	m
CSAH 78		
20+260 - 20+340	15 METERS RT LNB	80
20+545 - 20+610	15 METERS RT LNB	65
SUB TOTAL		145
CSAH 116		
5+685 - 5+750	10 METERS LT LWB	65
SUB TOTAL		65
TOTAL		210

RELOCATE HYDRANT AND VALVE (G)						
LOCATION		DESCRIPTION	RELOCATE TO		NO.	
STATION	LN FT		STATION	LN FT		
CSAH 116						
LWB	5+124.50	5.50 LT	LWB	5+124.50	10.00 LT	1
LWB	5+257.80	3.80 LT	LWB	5+257.80	12.00 LT	1
LWB	5+403.20	4.40 LT	LWB	5+403.20	12.00 LT	1
LWB	5+476.80	2.90 LT	LWB	5+476.80	8.50 LT	1
LWB	5+623.20	3.60 LT	LWB	5+623.20	12.00 LT	1
SUB TOTAL						3
CSAH 78						
LNB	20+671.50	5.50 RT	LNB	20+671.50		

STATEMENT OF ESTIMATED QUANTITIES

CH. NO.	ITEM NO.	ITEM	UNIT	TOTAL QUANTITIES		S.P. 02-678-12		S.P. 02-716-02		STORM SEWER	
				ESTIMATED	FINAL	ESTIMATED	FINAL	ESTIMATED	FINAL	ESTIMATED	FINAL
	2013.601	CELLULAR MOBILE TELEPHONE	LUMP SUM	1		0.5		0.5			
	2015.601	COMPUTER EQUIPMENT	LUMP SUM	1		0.5		0.5			
	2021.501	MOBILIZATION	LUMP SUM	1		0.5		0.5			
	2031.501	FIELD OFFICE TYPE D	EACH	1		0.5		0.5			
F	2101.501	CLEARING	ha	0.40		0.22		0.18			
F	2101.502	CLEARING	TREE	30		18		12			
F	2101.506	GRUBBING	ha	0.40		0.22		0.18			
F	2101.507	GRUBBING	TREE	30		18		12			
	2102.502	PAVT MARKING REMOVAL	m	5374		2687		2687			
C	2104.501	REMOVE CONCRETE CURB	m	15		11.2		3.8			
A&E	2104.503	REMOVE BITUMINOUS PAVEMENT	m ²	14 433		9063.1		5369.9			
T	2104.507	REMOVE GROUTED RIPRAP	m ³	4.5		4.5					
D	2104.509	REMOVE BITUMINOUS FLUME	EACH	1		1					
B	2104.513	SAWING BITUMINOUS PAVEMENT (FULL DEPTH)	m	2446		1125.72		1320.28			
T	2104.521	SALVAGE METAL CULVERTS	m	11				11			
T	2104.523	SALVAGE METAL SAFETY APRON	EACH	4				4			
T	2104.523	SALVAGE CONCRETE APRON	EACH	2		2					
T	2104.523	SALVAGE SIGN TYPE C	EACH	51		30		21			
V	2105.501	COMMON EXCAVATION	m ³	13 042(P)		7699		5343			
V	2105.521	GRANULAR BORROW (LV)	m ³	1898		898		1000			
V	2105.525	TOPSOIL BORROW (LV)	m ³	605		433		172			
	2130.501	WATER	m ³	60		35		25			
W&E	2211.503	AGGREGATE BASE (CV) CLASS-5A	m ³	2868(P)		1677.33		1190.76			
Q	2232.501	MILL BITUMINOUS SURFACE	m ²	718.6		525.2		193.4			
Y	2331.604	REPLACE TRENCH PAVEMENT	m ²	490		330		160			
E	2331.604	50 mm THICK BITUMINOUS WEARING COURSE	m ²	2918.9		890.8		2028.1			
W	2340.508	TYPE 47 WEARING COURSE MIXTURE	t	2580.88		1453.15		1127.73			
W	2340.510	TYPE 47 BINDER COURSE MIXTURE	t	2200.04		1319.93		880.11			
W	2340.514	TYPE 31 BASE COURSE MIXTURE	t	3378.42		2026.66		1351.76			
W	2357.502	BITUMINOUS MATERIAL FOR TACK COAT	L	8881.43		5124.56		3756.87			
T	2501.511	375 mm CS PIPE CULVERT	m	26.2				26.2			
T	2501.511	450 mm CS PIPE CULVERT	m	8.0				8.0			
U	2501.515	300 mm RC PIPE APRON	EACH	8							
T	2501.567	375 mm CS SAFETY APRON AND GRATE (3128)	EACH	2				2		8	
T&U	2501.573	INSTALL CONCRETE APRON	EACH	2		2					
T	2501.573	INSTALL METAL APRON	EACH	2				2			
U	2503.541	300 mm RC PIPE SEWER DESIGN 3006 CLASS III	m	98.9						92.9	
U	2503.541	375 mm RC PIPE SEWER DESIGN 3006 CLASS III	m	28.9						28.9	
U	2503.541	450 mm RC PIPE SEWER DESIGN 3006 CLASS III	m	67.9						67.9	
U	2503.541	600 mm RC PIPE SEWER DESIGN 3006 CLASS III	m	5						5	
U	2503.602	CONNECT TO EXISTING STORM SEWER	EACH	2						2	
H	2504.602	ADJUST VALVE BOX-WATER	EACH	9		4		5			
G	2504.602	RELOCATE HYDRANT AND VALVE	EACH	5		2		3			

STATEMENT OF ESTIMATED QUANTITIES

CH. NO.	ITEM NO.	ITEM	UNIT	TOTAL QUANTITIES		S.P. 02-678-12		S.P. 02-716-02		STORM SEWER	
				ESTIMATED	FINAL	ESTIMATED	FINAL	ESTIMATED	FINAL	ESTIMATED	FINAL
U	2506.501	CONSTRUCT DRAINAGE STRUCTURE DESIGN F	m	5.1							5.1
U	2506.501	CONSTRUCT DRAINAGE STRUCTURE DESIGN G	m	8.8							8.8
U	2506.501	CONSTRUCT DRAINAGE STRUCTURE DESIGN H	m	6.9							6.9
S	2506.516	CASTING ASSEMBLY	EACH	18							18
R&U	2506.602	ADJUST FRAME & RING CASTING (SPEC)	EACH	3		1		2			
U	2511.507	GROUTED RIPRAP	m ³	6.3		6.3					
N	2521.501	100mm CONCRETE WALK	m ²	1064.00		598.40		465.60			
N	2521.501	150mm CONCRETE WALK	m ²	14.55		8.50		6.05			
M	2531.501	CONCRETE CURB AND GUTTER, DESIGN B412	m	1297.6		717.3		580.3			
M	2531.501	CONCRETE CURB AND GUTTER, DESIGN B418	m	273.60				273.60			
O	2535.501	BITUMINOUS CURB	m	229.9		12.5		217.40			
X	2540.602	RELOCATE MAIL BOX SUPPORT	EACH	8		6		2			
L	2554.501	TRAFFIC BARRIER DESIGN B8307	m	7.80		7.80					
	2554.602	ECCENTRIC LOADER BCT	EACH	2		2					
	2563.601	TRAFFIC CONTROL STAGE 1	LUMP SUM	1		0.5		0.5			
	2563.601	TRAFFIC CONTROL STAGE 2	LUMP SUM	1		0.5		0.5			
	2563.601	TRAFFIC CONTROL STAGE 3	LUMP SUM	1		0.5		0.5			
	2563.601	TRAFFIC CONTROL STAGE 4	LUMP SUM	1		0.5		0.5			
	2563.610	POLICE OFFICER	hour	160		80		80			
	2564.531	SIGN PANELS TYPE C	m ²	43.66		21.80		21.86			
	2564.602	PAVT MESSAGE (LT ARROW) POLY PREF	EACH	8		4		4			
	2564.602	PAVT MESSAGE (RT ARROW) POLY PREF	EACH	8		4		4			
	2564.602	PAVT MESSAGE (ONLY) POLY PREF	EACH	8		4		4			
	2564.602	HAZARD MARKER X4-2	EACH	8		4		4			
	2564.602	CLEARANCE MARKER X4-4	EACH	8		4		4			
	2564.604	CROSSWALK MARKING - POLY PREFORMED	m ²	93.6		46.8		46.8			
	2564.603	100mm SOLID LINE WHITE - PAINT	m	3709		1753		1956			
	2564.603	600mm SOLID LINE WHITE - PAINT	m	48		24		24			
	2564.603	100mm SOLID LINE YELLOW - PAINT	m	1229		728		501			
	2564.603	100mm DOUBLE SOLID LINE YELLOW - PAINT	m	2780		1314		1466			
	2564.603	600mm SOLID LINE YELLOW - PAINT	m	211		94		117			
	2565.616	REVISE SIGNAL SYSTEM	SYSTEM	1		0.5		0.5			
J	2573.501	BALE CHECK	EACH	45		23		22			
J	2573.502	SILT FENCE, TYPE PREASSEMBLED	m	210		145		65			
K	2573.508	BITUMINOUS LINED FLUME	m ²	9.0		4.5		4.5			
I	2575.501	SEEDING	ha	1.63		0.9		0.73			
I	2575.502	SEED MIXTURE 70A	kg	81.5		45		36.5			
I	2575.505	SODDING, TYPE LAWN	m ²	6213		3443		2770			
I	2575.511	MULCH MATERIAL TYPE-1	t	7.3		4		3.3			
I	2575.519	DISK ANCHORING	ha	1.63		0.9		0.73			
T&U	2575.523	EROSION CONTROL BLANKETS, CATEGORY 1	m ²	115		43.0		72.0			
I	2575.532	COMMERCIAL FERTILIZER ANALYSIS 10-10-10	kg	912.8		504		408.8			
	2580.501	TEMPORARY LANE MARKING	m	4240		2120		2120			
	2581.501	REMOVABLE PREFORMED PLASTIC MARKING	m	1164		582		582			

BASIS OF PLANNED QUANTITIES

- 2340 TYPE 47 PLANT MIXED WEARING COURSE BITUMINOUS MIXTURE 60 kg/m /25 mm THICKNESS
- 2340 TYPE 31 PLANT MIXED BASE AND TYPE 47 PLANT MIXED BINDER COURSE BITUMINOUS MIXTURE 65 kg/m /25 mm THICKNESS
- 2357 BITUMINOUS MATERIAL FOR TACK 0.23 L/m PER LIFT APPLIED
- 2575 MULCH MATERIAL TYPE 1, 4.5 t/ha
- 2575 COMMERCIAL FERTILIZER, ANALYSIS 10-10-10 560 kg/ha ON ALL SEED AREAS
- 2575 ROADSIDE SEEDING BASED ON HORIZONTAL MEASUREMENT +10% SEED MIXTURE NO. 70A, 50 kg/ha

NOTES

- ① INCLUDES ALL BITUMINOUS PAVEMENTS REGARDLESS OF DEPTH AND WIDTH.
- ② 0.3m MILL MAY BE SUBSTITUTED FOR FULL DEPTH SAW CUT (SEE SPECIAL PROVISIONS).
- ③ SALVAGE TO ANOKA COUNTY HIGHWAY DEPARTMENT.
- ④ FOR DUST CONTROL AS DIRECTED BY THE ENGINEER.
- ⑤ INCLUDES 40m³ FOR AGGREGATE APPROACHES AND ENTRANCES (150mm THICK).
- ⑥ INCLUDES 350m² FOR TEMPORARY PAVEMENT WIDENING FOR STAGED CONSTRUCTION.
- ⑦ FOR DRIVEWAY CONSTRUCTION, SEE CHART E. INCLUDES 100mm AGGR. BASE CLASS-5.
- ⑧ INCLUDES 30m² FOR PED RAMPS.
- ⑨ FOR DEPRESSED MEDIAN NOSE (STD. PLATE M7109C).
- ⑩ FOR EROSION CONTROL AS SHOWN IN THE PLANS OR AS DIRECTED BY THE ENGINEER.
- ⑪ FOR USE AT CULVERT ENDS AND AS DIRECTED BY THE ENGINEER. SEE STD. PLATE M9102D.

INDEX OF TABULATION CHARTS

CHART	SHEET No.	DESCRIPTION
A	3	BITUMINOUS REMOVAL
B	3	SAWING BITUMINOUS PAVEMENT
C	3	CONCRETE CURB REMOVAL
D	3	FLUME REMOVAL
E	3	ENTRANCES REMOVAL AND CONSTRUCTION
F	3	CLEARING AND GRUBBING
G	3	RELOCATE HYDRANT AND VALVE
H	3	ADJUST VALVE BOX-WATER
I	3	TURF ESTABLISHMENT
J	3	SILT FENCE LOCATION
K	4	CONSTRUCTION BITUMINOUS FLUME
L	4	GUARDRAIL CONSTRUCTION
M	4	CONCRETE CURB AND GUTTER
N	4	CONSTRUCTION 100mm CONCRETE WALK
D	4	BERM CONSTRUCTION LOCATION
P	4	CONSTRUCTION BITUMINOUS CURB
D	4	MILL BITUMINOUS SURFACE
R	4	SANITARY SEWER MODIFICATION
S	4	DRAINAGE CASTING SCHEDULE
T	4	CULVERT TABULATION
U	4	STORM SEWER TABULATION
V	5	EARTH WORK SUMMARY
W	5	BASE AND BITUMINOUS QUANTITIES CHART
X	4	MAILBOX RELOCATION
Y	4	REPLACE TRENCH PAVEMENT

STANDARD PLATES

THESE STANDARD PLATES AS APPROVED BY THE FHWA SHALL APPLY.

PLATE NO.	DESCRIPTION
M3000 L	REINFORCED CONCRETE PIPE
M3006 G	GASKET JOINT FOR R.C. PIPE
M3040 F	CORRUGATED METAL PIPE CULVERT
M3100 G	CONCRETE APRON FOR REINFORCED CONCRETE PIPE
M3128 F	SAFETY APRON
M3133 C	RIPRAP AT RCP OUTLETS
M3145 E	CONCRETE PIPE TIES
M3221 C	CORRUGATED STEEL PIPE COUPLING BAND
M4005 L	MANHOLE OR CATCH BASIN
M4006 L	MANHOLE OR CATCH BASIN
M4010 H	CONCRETE SHORT CONE AND ADJUSTING RING
M4011 E	PRECAST CONCRETE BASE
M4126 F	CATCH BASIN FRAME CASTING
M4149 C	GRATE CASTING FOR CATCH BASIN
M4161 F	CURB BOX CASTING FOR CATCH BASIN
M7065 C	BITUMINOUS CURB
M8000 I	STANDARD BARRICADES
M9102 D	TURF ESTABLISHMENT AREAS (AT PIPE CULVERT ENDS)
M7100 G	CONCRETE CURB AND GUTTER
M7109 C	MEDIAN NOSE AND ISLAND
M8307 P	STEEL PLATE BEAM GUARDRAIL
M8329 F	ECCENTRIC LOADER BREAKAWAY CABLE TERMINAL (ELT)

SEE TRAFFIC SIGNAL PLAN SHEETS FOR ADDITIONAL STANDARD PLATES

1	6/15/99	KLD	LAR		Items with bold italics and strikethroughs show the change of the west leg of CSAH 116 from rural to urban section.</
---	---------	-----	-----	--	---

PLAN SYMBOLS

- COUNTY LINE
- TOWNSHIP OR RANGE LINE
- SECTION LINE
- QUARTER LINE
- SIXTEENTH LINE
- RIGHT OF WAY LINE
- SLOPE EASEMENT
- PRESENT RIGHT OF WAY
- PROPERTY LINE
- CORPORATE OR CITY LIMITS
- RETAINING WALL
- RAILROAD
- RAILROAD RIGHT OF WAY
- RIVER OR CREEK
- DRAINAGE DITCH
- CULVERT
- DROP INLET
- GAURD RAIL
- BARBED WIRE FENCE
- WOVEN WIRE FENCE
- CHAIN LINK FENCE
- WOOD FENCE
- STONE WALL OR FENCE
- HEDGE

- LOWLAND
- TIMBER
- ORCHARD
- BRUSH
- NURSERY

- CATTLE GAURD
- OVERPASS (Highway Over)
- UNDERPASS (Highway Under)
- BRIDGE
- BUILDING (One Story Frame)
- F-FRAME C-CONCRETE
- S-STONE T-TILE
- B-BRICK ST-STUCCO
- RAILROAD CROSSING BELL
- RAILROAD CROSSING GATE
- MANHOLE
- CATCH BASIN
- FIRE HYDRANT
- CAST IRON MONUMENT
- IRON PIN
- GRAVEL PIT
- SH&D PIT
- BORROW PIT
- ROCK QUARRY

UTILITY SYMBOLS

- POWER POLE LINE
- TELEPHONE OR TELEGRAPH POLE LINE
- JOINT TELEPHONE & POWER ON POWER POLES
- ON TELEPHONE POLES
- ANCHOR
- STEEL TOWER
- STREET LIGHT
- PEDESTAL (Cable Terminal)
- GAS MAIN
- WATERMAIN
- TELEPHONE CABLE IN CONDUIT
- ELECTRIC CABLE IN CONDUIT
- TELEPHONE MANHOLE
- ELECTRIC MANHOLE
- BURIED TELEPHONE CABLE
- BURIED ELECTRIC CABLE
- AERIAL TELEPHONE CABLE
- SEWER (Sanitary or Storm)
- SEWER MANHOLE

SCALES

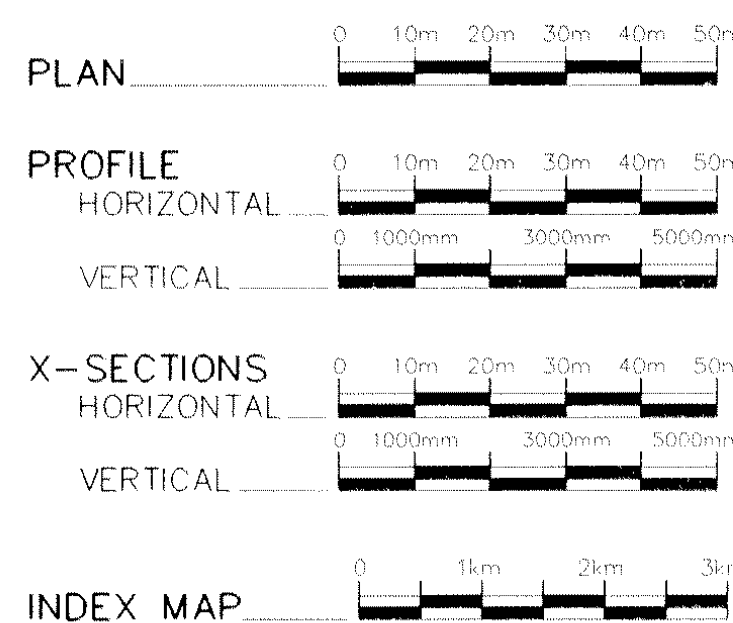

MINNESOTA DEPARTMENT OF TRANSPORTATION

ANOKA COUNTY

CONSTRUCTION PLAN FOR GRADING, AGG.BASE, BITUMINOUS SURFACING, DRAINAGE, CURB & GUTTER AND SIGNAL SYSTEM.

LOCATED ON CSAH 78 FROM 420.000 m So. of CSAH 116 to 311.160 m No. of CSAH 116 and
CSAH 116 FROM 163.385 m W. of CSAH 78 to 350.310 m E. of CSAH 78, in Andover (Geographic Description)

STATE PROJ. NO. 02-678-12 STATE PROJ. NO. 02-716-02
C.S.A.H. 78 C.S.A.H. 116

GROSS LENGTH <u>731.160</u> METERS <u>0.731</u> KILOMETERS	GROSS LENGTH <u>513.695</u> METERS <u>0.514</u> KILOMETERS
BRIDGES-LENGTH <u>0.000</u> METERS <u>0.000</u> KILOMETERS	BRIDGES-LENGTH <u>0.000</u> METERS <u>0.000</u> KILOMETERS
EXCEPTIONS-LENGTH <u>0.000</u> METERS <u>0.000</u> KILOMETERS	EXCEPTIONS-LENGTH <u>20.100</u> METERS <u>0.020</u> KILOMETERS
NET LENGTH <u>731.160</u> METERS <u>0.731</u> KILOMETERS	NET LENGTH <u>493.595</u> METERS <u>0.494</u> KILOMETERS

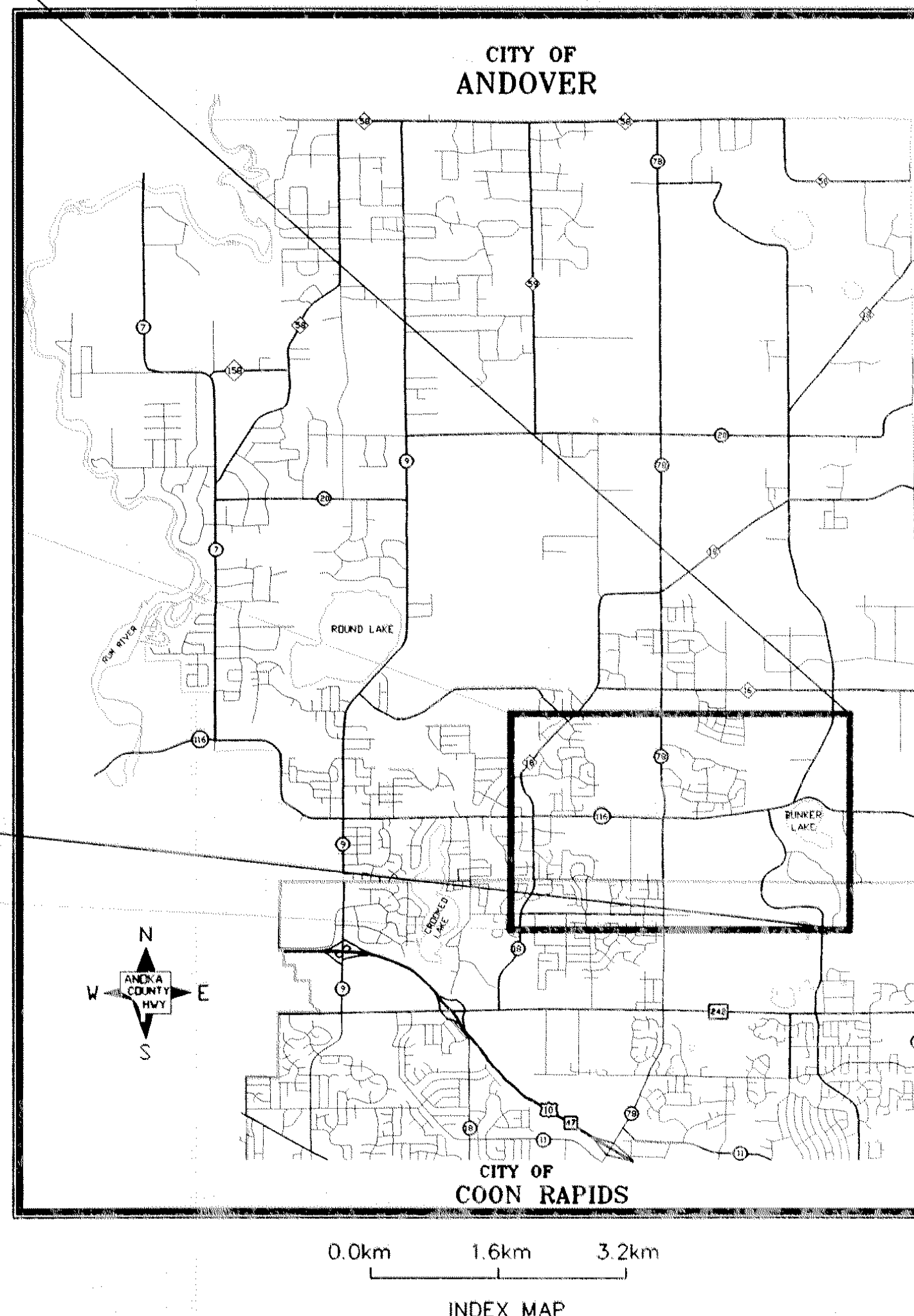
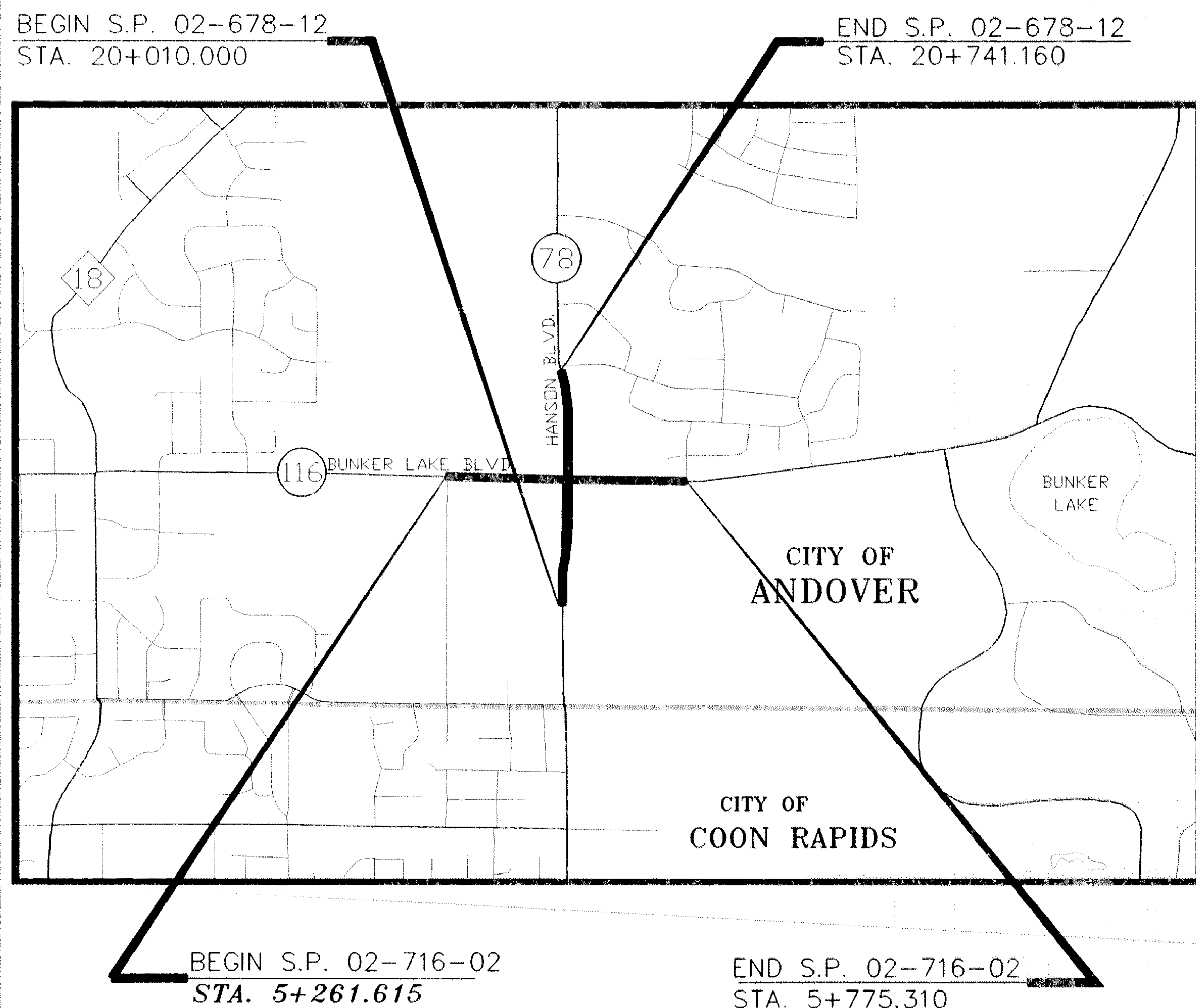

MINN. PROJ. NO. STPF 0299 (064)
 MINN. PROJ. NO. _____

GOVERNING SPECIFICATIONS

THE 1995 EDITION OF THE MINNESOTA DEPARTMENT OF TRANSPORTATION "STANDARD SPECIFICATIONS FOR CONSTRUCTION" SHALL GOVERN. ALL TRAFFIC CONTROL DEVICES SHALL CONFORM TO THE MMUTCD, INCLUDING "FIELD MANUAL FOR TEMPORARY TRAFFIC CONTROL ZONE LAYOUTS - JANUARY 1998."

INDEX

SHEET NO.	DESCRIPTION
1	TITLE SHEET
2	STATEMENT OF ESTIMATED QUANTITIES
3 - 4	TABULATION CHARTS
5	EARTHWORK SUMMARY
6 - 7	EROSION CONTROL DETAILS
8 - 9	TYPICAL SECTIONS
10	DETAIL AND SUPER ELEVATION
11 - 12	EXISTING CONDITIONS AND REMOVAL PLAN
13 - 16	PLAN AND PROFILE SHEETS
17 - 22	TRAFFIC SIGNAL SYSTEM
23 - 27	SIGNING & STRIPING PLAN AND TAB
28 - 42	CROSS-SECTION
43 - 59	TRAFFIC CONTROL PLAN AND TAB

THIS PLAN CONTAINS 59 SHEETS

DESIGN DESIGNATION

	<u>CSAH 78</u>	<u>CSAH 116</u>
ESAL ₂₀	3 006 936	2 416 726
R VALUE	70	70
ADT (1998) =	15545	12493
Proj. ADT (2018) =	26426	21238
Proj. HCADT (2018) =	1982	1593
Soil Factor	NA	NA
<u>8.2 METRIC TON DESIGN</u>		

CSAH 78 & CSAH 116
 Functional Classification ARTERIAL HIGH DENSITY
 No. of Traffic Lanes 2 Shoulder Width 3.6 m
 Design Speed 90 Km/h
 Based on Stopping Sight Distance _____
 Height of eye 1070 mm Height of object 150 mm
 Design Speed not achieved at:
 STA. 20+524.000 TO STA. 20+640.000 KM/H 80
 STA. 20+679.700 TO STA. 20+741.160 KM/H 80
 STA. _____ TO STA. _____ MPH

Approved _____, 19____ ANOKA COUNTY ENGINEER
 Approved _____, 19____ CITY OF ANDOVER
 Approved _____, 19____ DISTRICT STATE AID ENGINEER: REVIEWED FOR COMPLIANCE WITH STATE AND FEDERAL AID RULES/POLICY
 Recommended for Approval _____, 19____ STATE TRAFFIC ENGINEER
 Approved _____, 19____ APPROVED FOR STATE AND FEDERAL AID FUNDING: STATE AID ENGINEER

1	6/15/99	KLD	LAR	Items with bold italics and strikethroughs show the change of the west leg of CSAH 116 from rural to urban section.
NO	DATE	BY	CKD	APPR
NAME:	78-title.dwg	4-27-99	3:21:24 pm	EST M.N.

REVISION

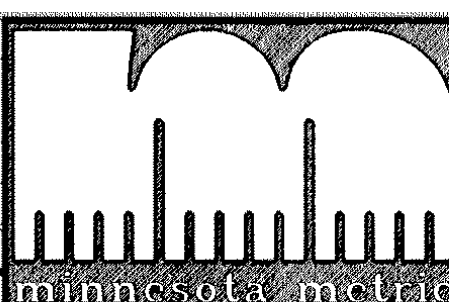

I HEREBY CERTIFY THAT THIS PLAN WAS PREPARED BY ME OR UNDER MY DIRECT SUPERVISION AND THAT I AM A DULY REGISTERED PROFESSIONAL ENGINEER UNDER THE LAWS OF THE STATE OF MINNESOTA.

DATE _____ REG. NO. _____

DRAWN BY _____ MN DATE 04/27/98
 DESIGN BY DWF DATE 04/27/98
 CHECKED BY DWF DATE 04/27/98



ANOKA COUNTY
HIGHWAY DEPT.

STATE PROJECT NO. 02-678-12/02-716-02
 STATE AID PROJECT NO. _____
 STATE AID PROJECT NO. _____
 COUNTY PROJECT NO. _____

TITLE SHEET

Sheet 1 of 59 Sheets

Fed. Project No. _____

END S.A.P. 02-716-02
LEB STA. 5+775.31

MATCH LINE STA. 5+420

LWB 31.50 LT
STA: 5+448.60
15m RAD

EXISTING R/W
8.79m TO LWB

LEB 18.60 RT
STA: 5+450.04
15m RAD

ANKA COUNTY
SHERIFF DEPT
BUILDING

$\Delta = 20^{\circ}41'17''$
 $R = 150.00m$
 $T = 27.38m$
 $L = 54.16m$

LEB STA. 5+675.62=
HWY. ENT. C/L 1+000

FULL DEPTH CONSTRUCTION

278
276
274
272
270

278
276
274
272
270

EXISTING GRADE
CARRID 3.6m LT
OF E.B. CD. 116

PROFILE GRADE
CARRID 3.6m LT
OF E.B. CD. 116

END SP 02-716-02
STA: 5+775.31

PVI STA= 5+775.31
ELEV= 273.534

273.634
273.59
273.566
273.57
273.487
273.60
273.530
273.61
273.572
273.60
273.615
273.57
273.658
273.54
273.652
273.50
273.597
273.49
273.543
273.44
273.488
273.39
273.434
273.35
273.380
273.31
273.325
273.33
273.323
273.31
273.372
273.36
273.422
273.46
273.472
273.52
273.521
273.58

NO	DATE	BY	CKD	APPR	REVISION



I HEREBY CERTIFY THAT THIS PLAN WAS PREPARED BY ME OR UNDER MY DIRECT SUPERVISION AND THAT I AM A DULY REGISTERED PROFESSIONAL ENGINEER UNDER THE LAWS OF THE STATE OF MINNESOTA.

DATE _____ REC. NO. _____

DRAWN BY _____ DATE _____
DESIGN BY _____ DATE _____
CHECKED BY _____ DATE _____

STATE PROJECT NO. 02-678-12
STATE PROJECT NO. 02-716-02
STATE AID PROJECT NO. _____
COUNTY PROJECT NO. _____

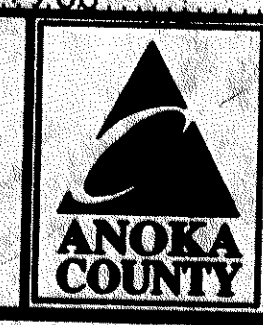

ANOKA COUNTY
HIGHWAY DEPT.

PLAN AND PROFILE
C.S.A.H. 116
STA. 5+420.00 TO STA. 5+800.00
Sheet 13 of 27 Sheets

BEGIN S.A.P. 02-716-02
LEB STA. 5+072.58

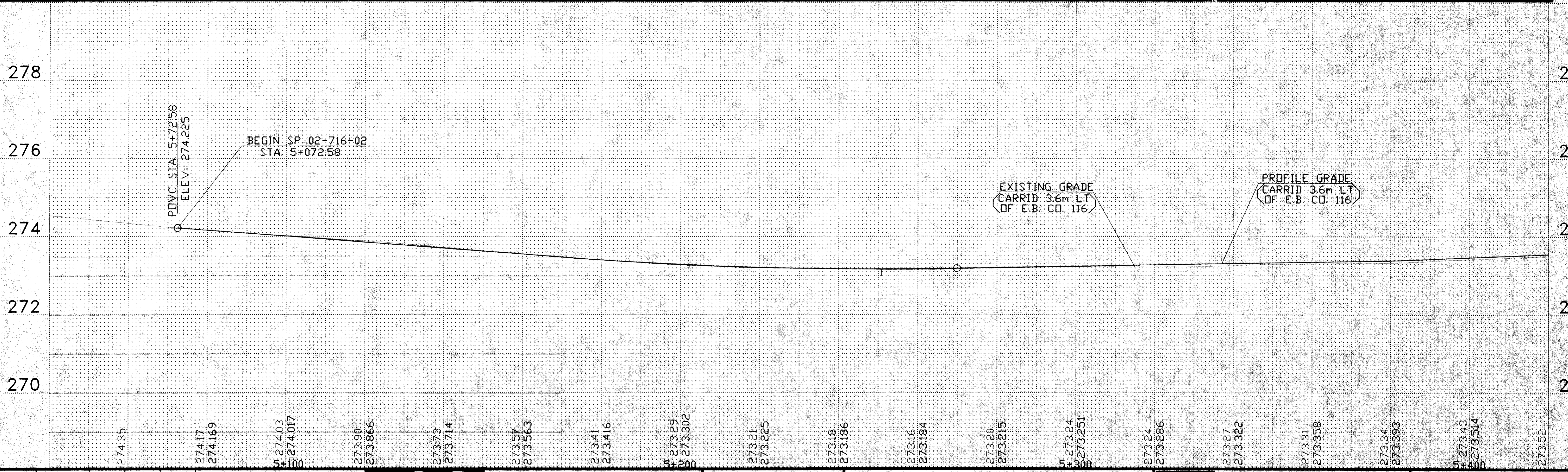
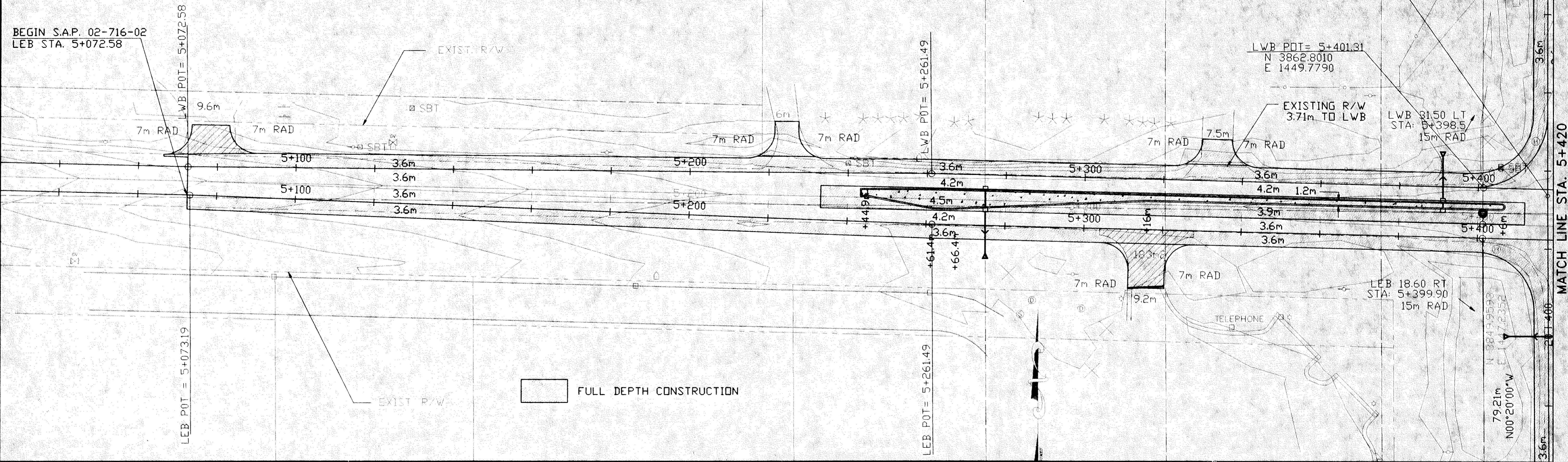

NO	DATE	BY	CKD	APPR	REVISION



I HEREBY CERTIFY THAT THIS PLAN WAS PREPARED BY ME OR UNDER MY DIRECT SUPERVISION AND THAT I AM A DULY REGISTERED PROFESSIONAL ENGINEER UNDER THE LAWS OF THE STATE OF MINNESOTA.

DATE _____ REG. NO. _____

DRAWN BY _____ DATE _____
DESIGN BY _____ DATE _____
CHECKED BY _____ DATE _____

STATE PROJECT NO. 02-678-12
STATE PROJECT NO. 02-716-02
STATE AID PROJECT NO. _____
COUNTY PROJECT NO. _____



ANOKA COUNTY
HIGHWAY DEPT.

PLAN AND PROFILE
C.S.A.H. 116
STA. 5+040.00 TO STA. 5+420.00
Sheet 12 of 27 Sheets

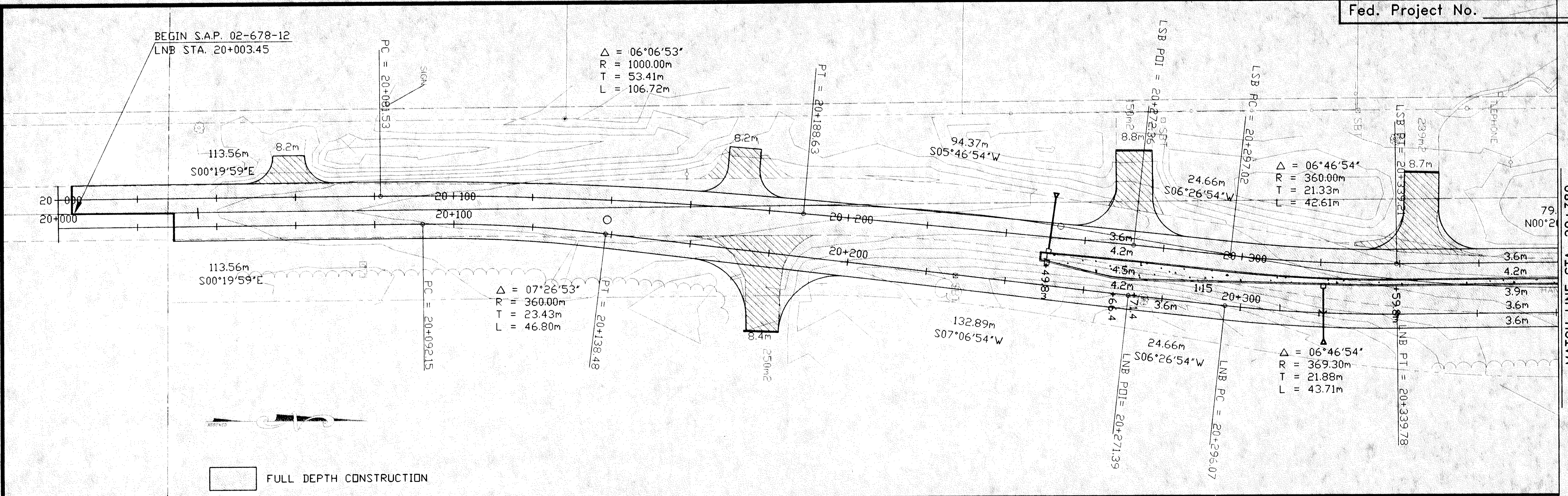

MATCH LINE STA. 20+380

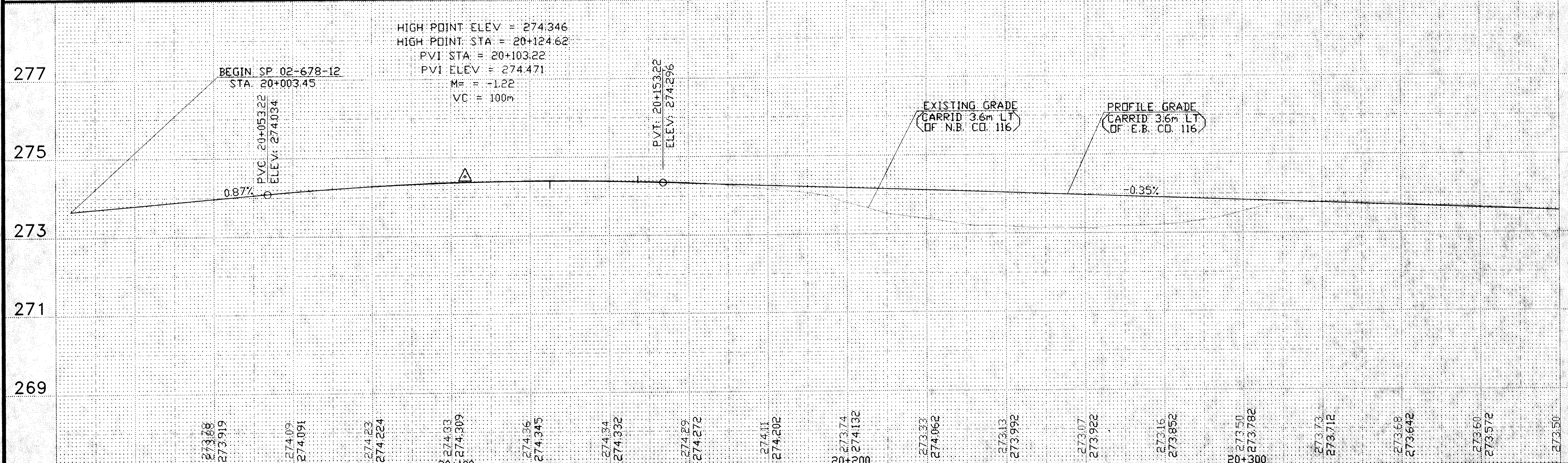

NO	DATE	BY	CKD	APPR	REVISION



I HEREBY CERTIFY THAT THIS PLAN WAS PREPARED BY ME OR UNDER MY DIRECT SUPERVISION AND THAT I AM A DULY REGISTERED PROFESSIONAL ENGINEER UNDER THE LAWS OF THE STATE OF MINNESOTA.

DATE _____ REG. NO. _____

DRAWN BY _____ DATE _____
 DESIGN BY _____ DATE _____
 CHECKED BY _____ DATE _____

STATE PROJECT NO. 02-678-12
 STATE PROJECT NO. 02-716-02
 STATE AID PROJECT NO. _____
 COUNTY PROJECT NO. _____

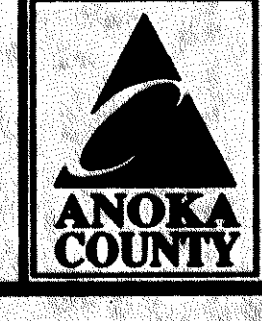

ANOKA COUNTY
HIGHWAY DEPT.

PLAN AND PROFILE
 C.S.A.H. 78
 STA. 20+000.00 TO 20+380.00
 Sheet 10 of 27 Sheets

LEB STA. 5+072.58

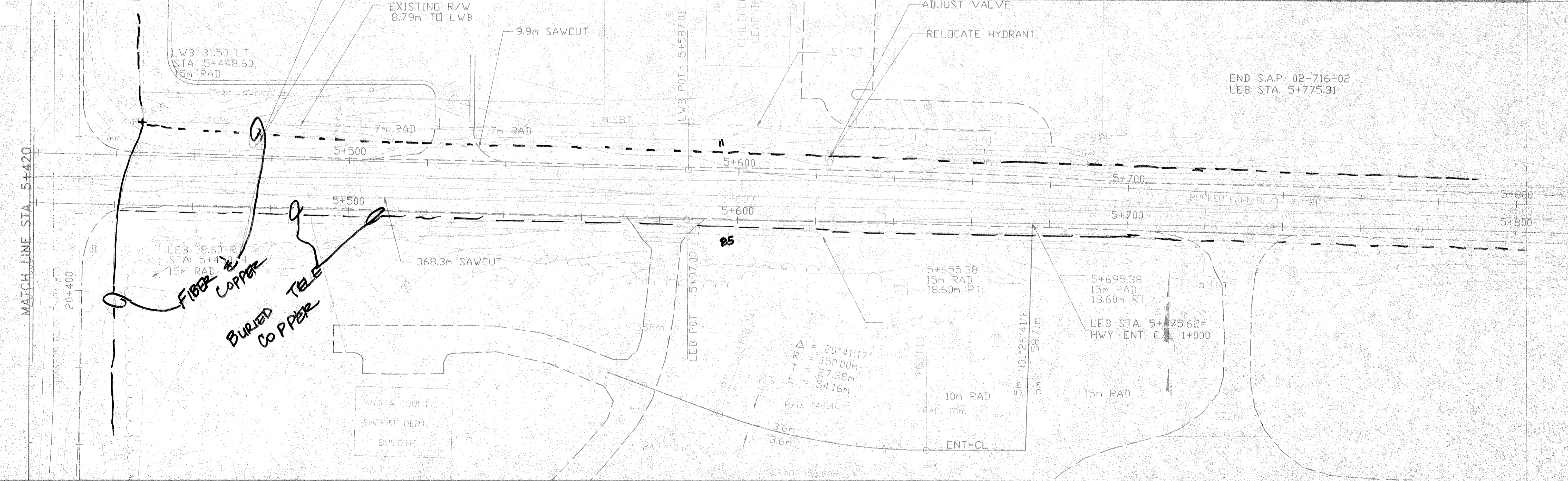
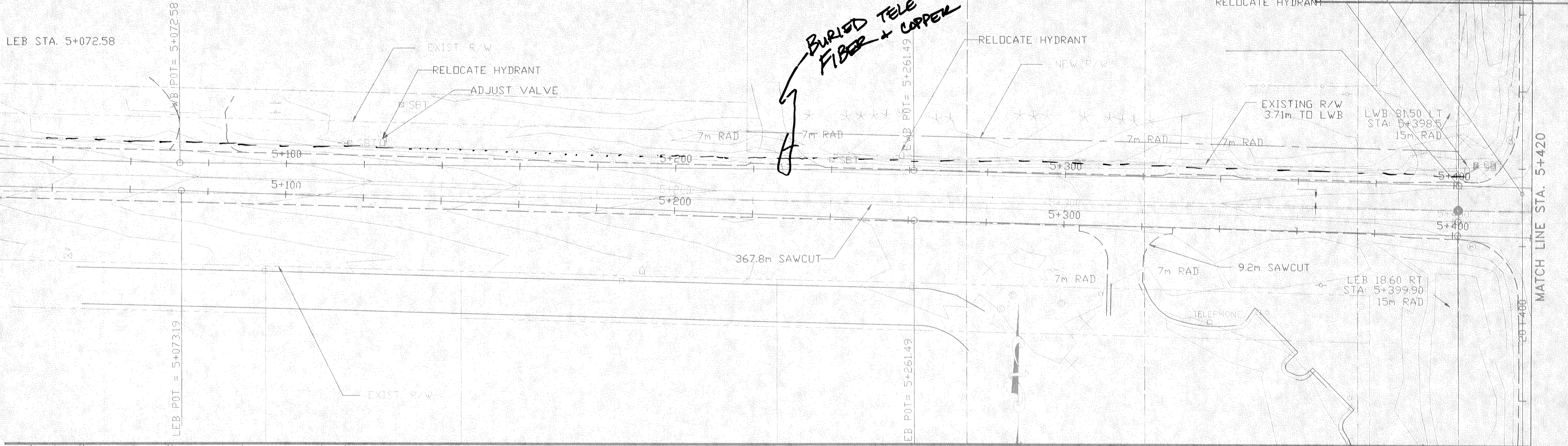

END S.A.P. 02-716-02
LEB STA. 5+775.31

NO	DATE	BY	CKD	APPR	REVISION



I HEREBY CERTIFY THAT THIS PLAN WAS PREPARED BY ME OR UNDER MY DIRECT SUPERVISION AND THAT I AM A DULY REGISTERED PROFESSIONAL ENGINEER UNDER THE LAWS OF THE STATE OF MINNESOTA.

REG. NO. _____

DRAWN BY _____ DATE _____
 DESIGN BY _____ DATE _____
 CHECKED BY _____ DATE _____

STATE PROJECT NO. 02-678-12
 STATE PROJECT NO. 02-716-02
 STATE AID PROJECT NO. _____
 COUNTY PROJECT NO. _____



**ANOKA COUNTY
HIGHWAY DEPT.**

**EXISTING CONDITIONS
AND REMOVAL PLAN**
 C.S.A.H. 116
 Sheet 9 of 27 Sheets

LEB STA. 5+072.58

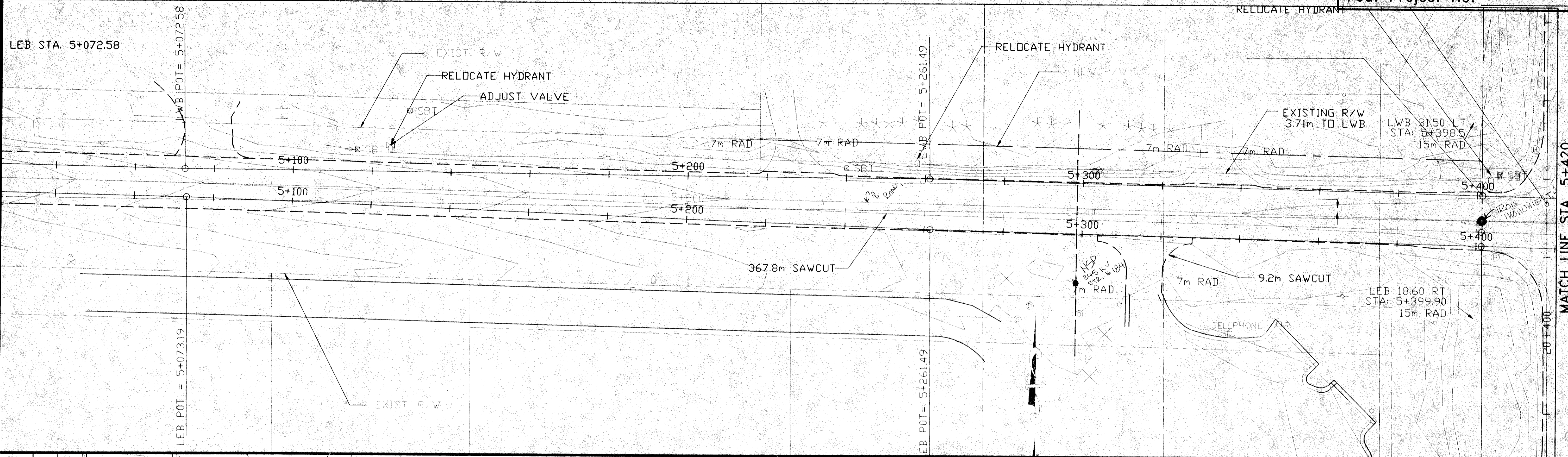

MATCH LINE STA. 5+420

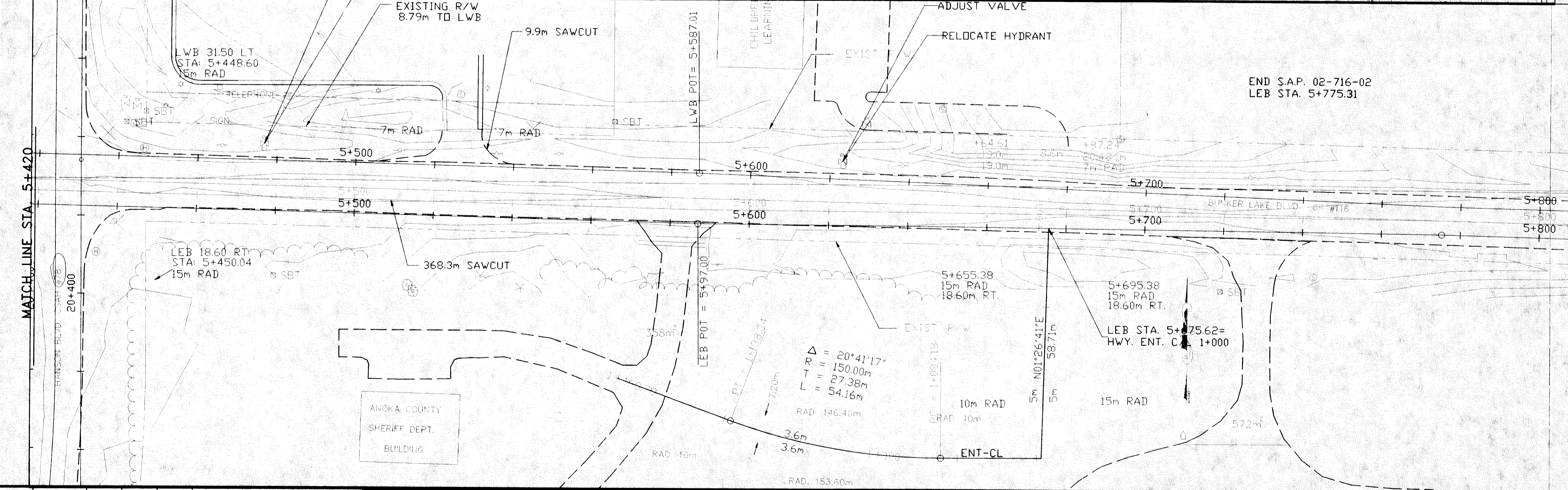

END S.A.P. 02-716-02
LEB STA. 5+775.31

MATCH LINE STA. 5+420

NO	DATE	BY	CKD	APPR	REVISION



I HEREBY CERTIFY THAT THIS PLAN WAS PREPARED BY ME OR UNDER MY DIRECT SUPERVISION AND THAT I AM A DULY REGISTERED PROFESSIONAL ENGINEER UNDER THE LAWS OF THE STATE OF MINNESOTA.

REG. NO. _____ DATE _____

DRAWN BY _____ DATE _____
DESIGN BY _____ DATE _____
CHECKED BY _____ DATE _____

STATE PROJECT NO. 02-678-12
STATE PROJECT NO. 02-716-02
STATE AID PROJECT NO. _____
COUNTY PROJECT NO. _____

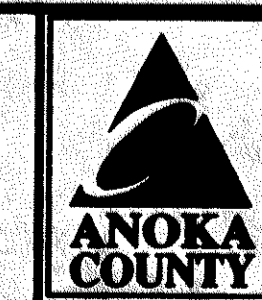

**ANOKA COUNTY
HIGHWAY DEPT.**

**EXISTING CONDITIONS
AND REMOVAL PLAN**
C.S.A.H. 116
Sheet 9 of 27 Sheets

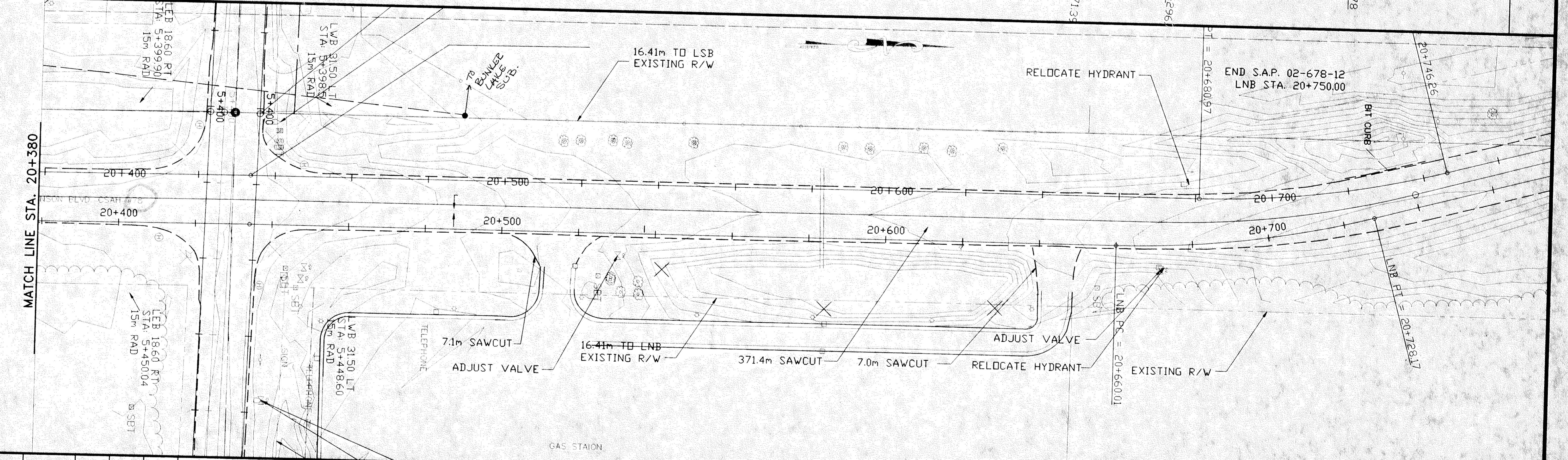
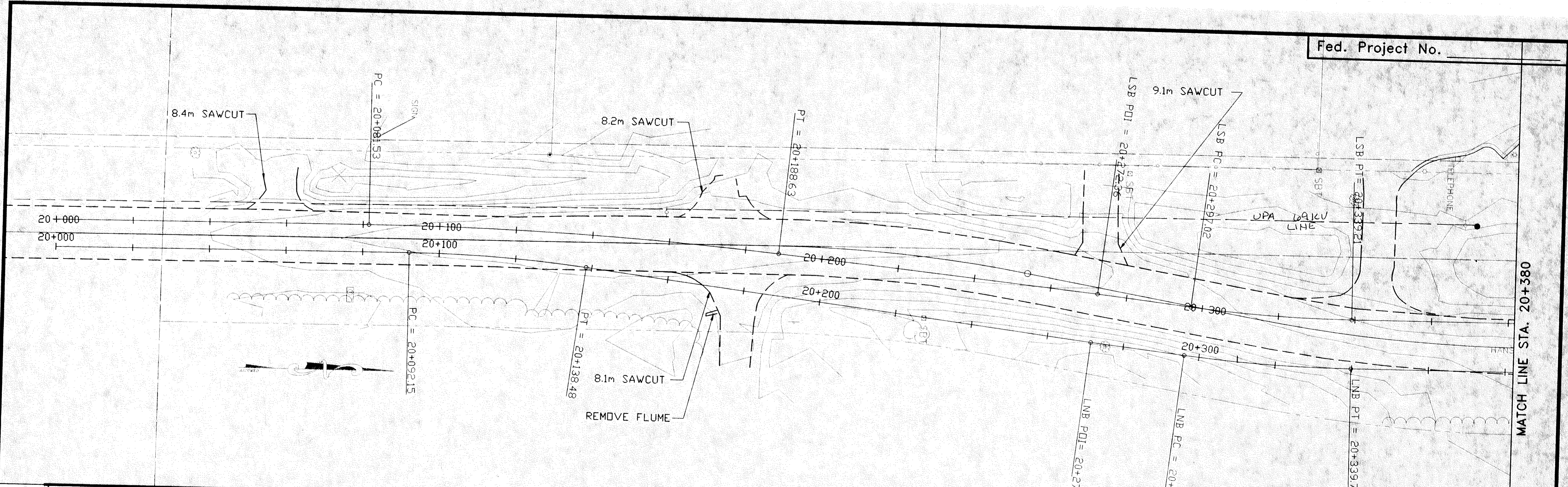

NO	DATE	BY	CHKD	APPR	REVISION



I HEREBY CERTIFY THAT THIS PLAN WAS PREPARED BY ME OR UNDER MY DIRECT SUPERVISION AND THAT I AM A DULY REGISTERED PROFESSIONAL ENGINEER UNDER THE LAWS OF THE STATE OF MINNESOTA.

DATE _____ REG. NO. _____

DRAWN BY _____ DATE _____
 DESIGN BY _____ DATE _____
 CHECKED BY _____ DATE _____

STATE PROJECT NO. 02-678-12
 STATE PROJECT NO. 02-716-02
 STATE AID PROJECT NO. _____
 COUNTY PROJECT NO. _____

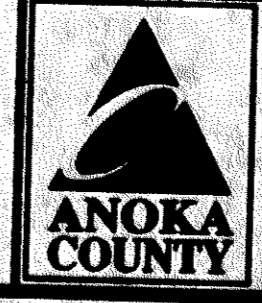

**ANOKA COUNTY
 HIGHWAY DEPT.**

**EXISTING CONDITIONS
 AND REMOVAL PLAN**
 C.S.A.H. 78
 Sheet 8 of 27 Sheets

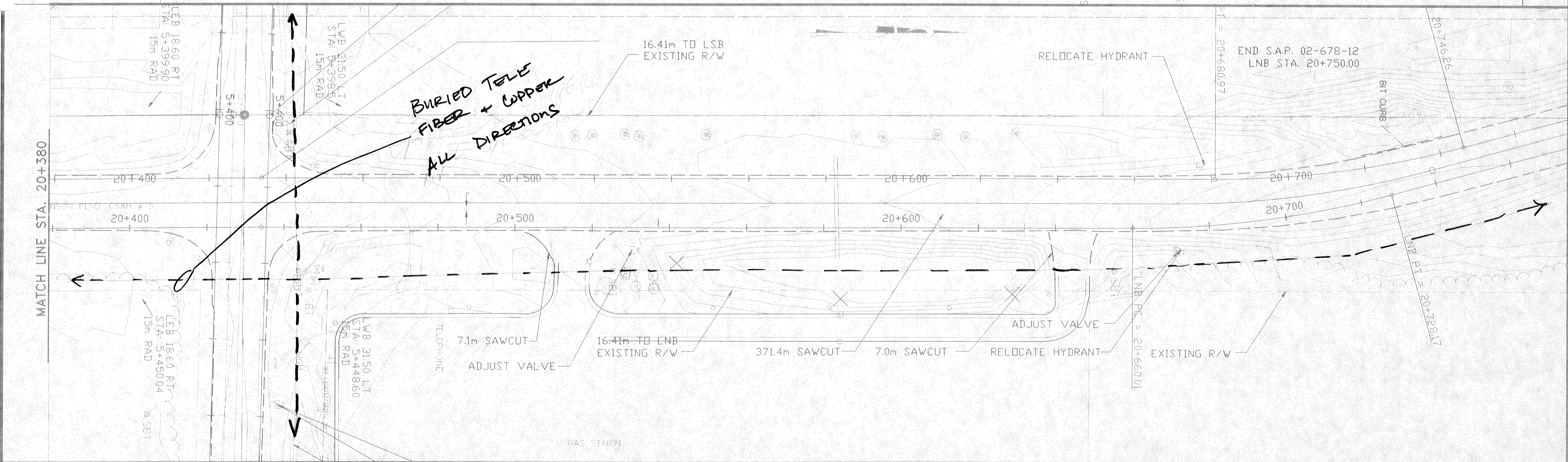
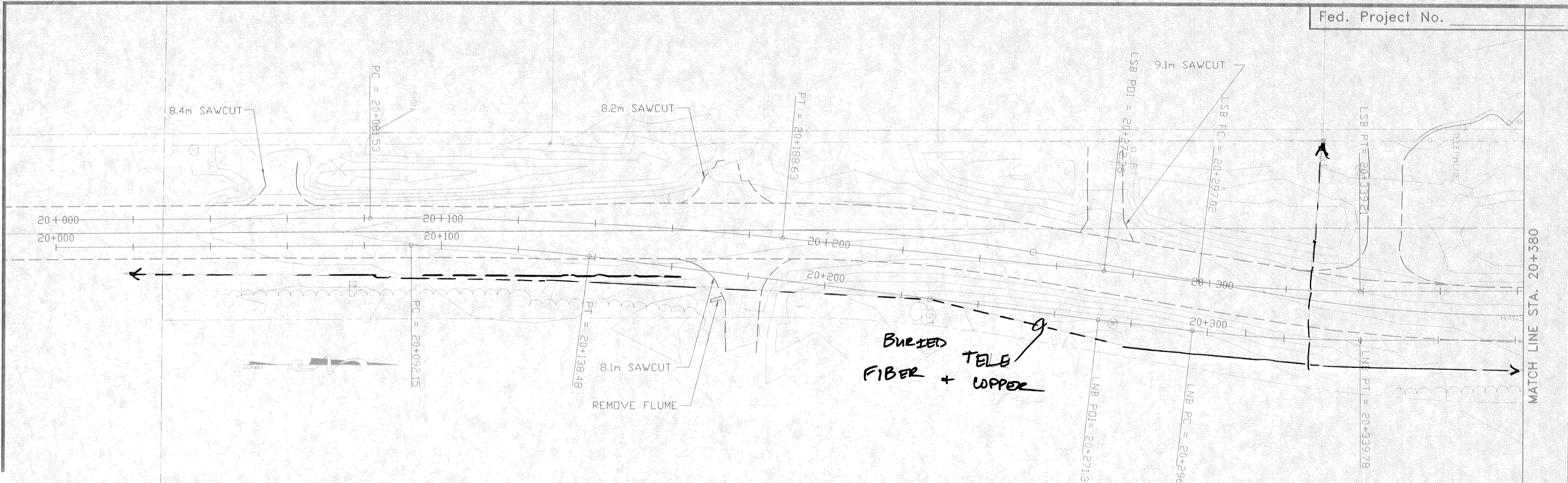

NO.	DATE	BY	CHKD	APPR	REVISION

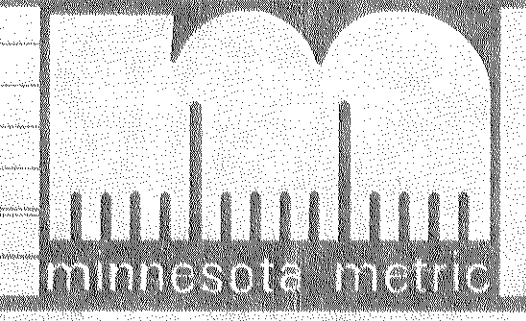

I HEREBY CERTIFY THAT THIS PLAN WAS PREPARED BY ME OR UNDER MY DIRECT SUPERVISION AND THAT I AM A DULY REGISTERED PROFESSIONAL ENGINEER UNDER THE LAWS OF THE STATE OF MINNESOTA.

DATE _____ REG. NO. _____

DRAWN BY _____ DATE _____
 DESIGN BY _____ DATE _____
 CHECKED BY _____ DATE _____

STATE PROJECT NO. 02-678-12
 STATE PROJECT NO. 02-716-02
 STATE AID PROJECT NO. _____
 COUNTY PROJECT NO. _____

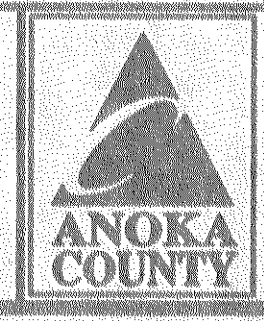

ANOKA COUNTY
 HIGHWAY DEPT.

EXISTING CONDITIONS AND REMOVAL PLAN
 C.S.A.H. 78
 Sheet 8 of 27 Sheets

230KV "PE" LINE
 795 MCM ACSR 45/7
 8080# D.T. 700' R.S.
 69KV "EF" LINE
 397.5 MCM ACSR 24/7
 6000# D.T. 600' R.S.
 7/16" H.S.S. O.H.W.
 4900# D.T. 700' R.S.

PLAN AND PROFILE
 STATION 605+00 TO 665+00

SCALE:
 Horizontal 1"=200'
 Vertical 1"=20'

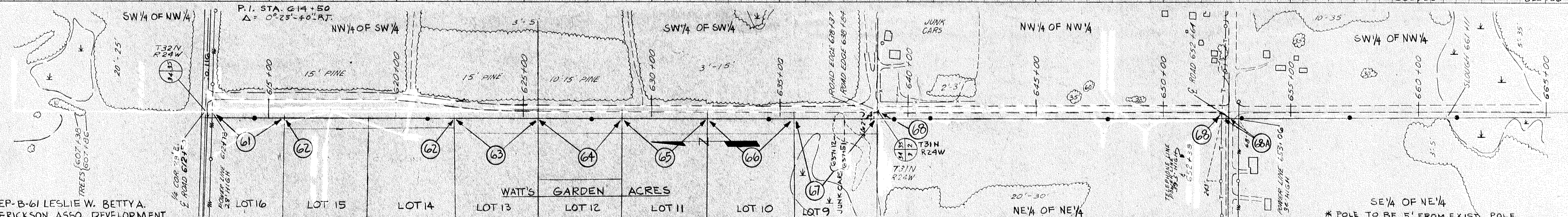
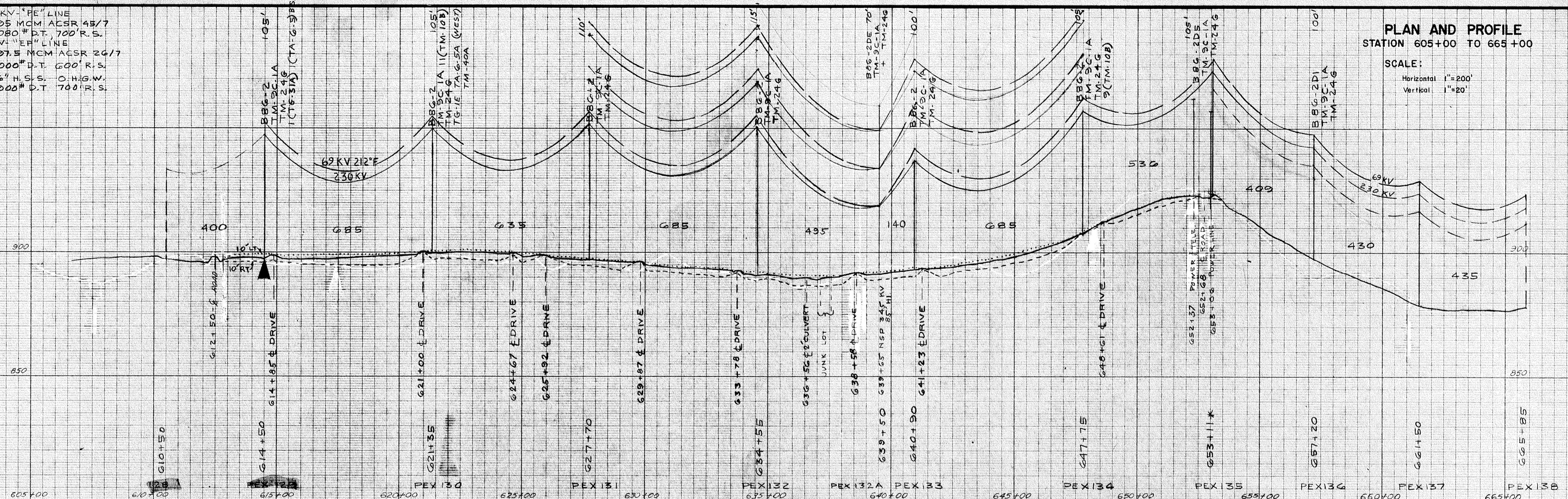

- 61- EP-B-61 LESLIE W. BETTYA. ERICKSON ASSO. DEVELOPMENT
- 62- EP-B-62 CARL E. AND CATHERINE M. SORENSON
- 63- EP-B-63 CHARLOTTE C. SULLIVAN
- 64- EP-B-64 GEORGIA E. HALL
- 65- EP-B-65 GERALD J. AND SHIRLEY JURVA
- 66- EP-B-66 EDWIN L. AND JESSIE M. WESTLUND
- 67- EP-B-67 HENRY F. AND LYDIA OTIS PART. EASE REL. 4-28-72
- 68- EP-C-68 EARL S. AND FERN BERGERON
- 68A- EP-C-68A T.H. 242 PERMIT NO. 5AU-67-168



PEX

UNITED POWER ASSOCIATION ELK RIVER, MINNESOTA K. B. MACKICHAN & ASSOCIATES Grand Forks, & Minot, N. Dak. Redwood Falls, Minn.	
ELK RIVER TO PARKWOOD - 230KV DAYTONPORT TO PARKWOOD - 69 KV	
11/2/83 ADD GUY & ANCHOR TO STR #130 W.O. 242821* 6-26-73 ADD STRUCTURE #132A W.O. U87 ISSUE 22 3-73 REV. FOR ROAD CONST. STRS 129-135. 12-71 REV. FOR W.O. U86 DRH 9-2-70 CHG'D FROM TM-24F TO TM-24G 8/31/70 PEX 135 WAS C-5840G, ADDED NOTE *	Date: NOV. 9, 1965 Scale: Hor. 1"=200' Ver. 1"=20' Voltage: PE' LINE - 230 KV EF' LINE - 69 KV
Dwn. by: JRC DRH Appd. by: W.O. No. 01999	Sta. 605+00 to Sta. 665+00 TPEX-91D SH. 4

230KV-PE LINE
 795 MCM ACSR 45/7
 8080# D.T. 700' R.S.
 69KV-EP LINE
 397.5 MCM ACSR 26/7
 6000# D.T. 600' R.S.
 T/16" H.S.S. O.H.G.W.
 4990# D.T. 700' R.S.

PLAN AND PROFILE
 STATION 550+00 TO 610+00

SCALE:
 Horizontal 1"=200'
 Vertical 1"=20'

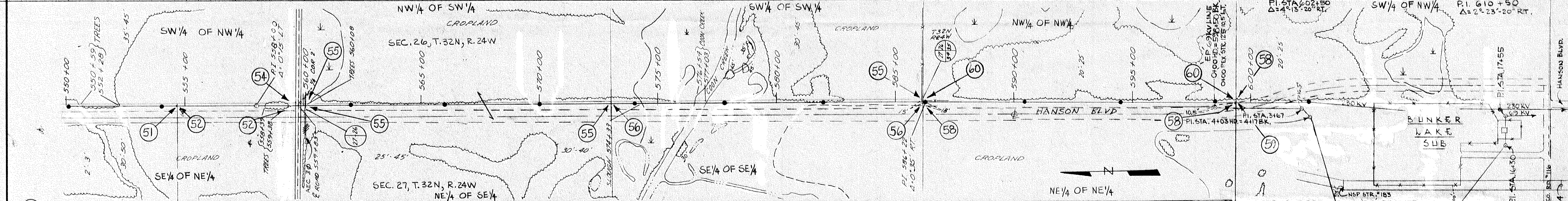
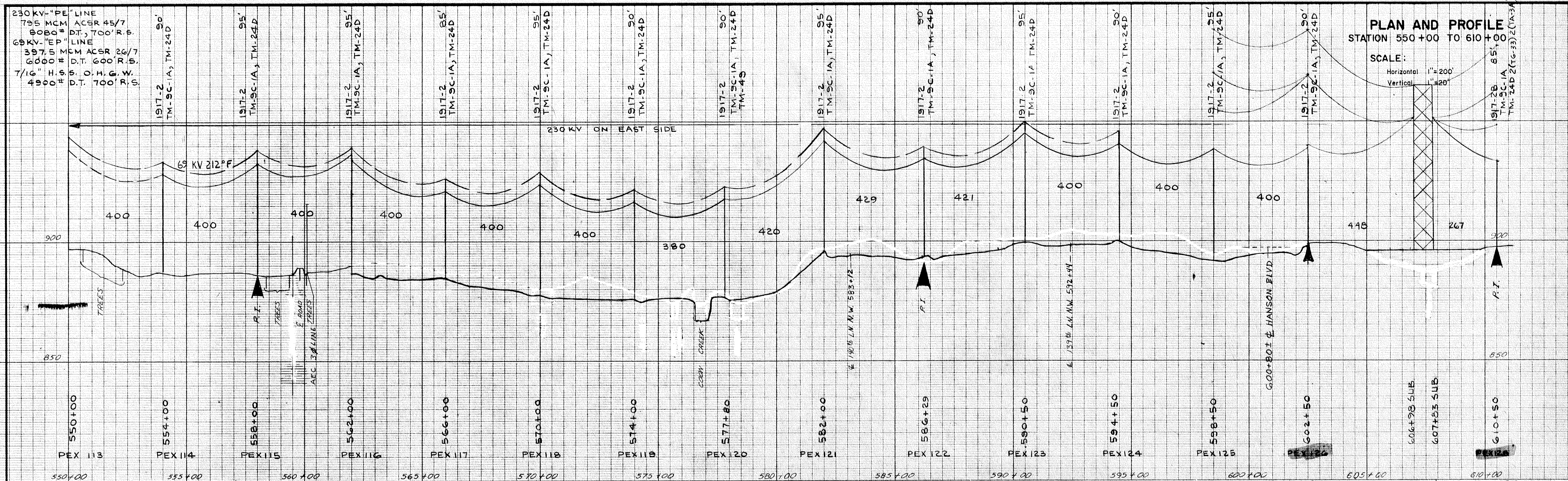

- 51 - EP-B-51 JOHN E. RUSSELL ALICE RUSSELL (PART. EASE REL. 1/11/76)
- 52 - EP-B-52 DANIEL & CAROL E. JONES INCLUDES BLANKET ESMT. AND BLANCH A. AMUNDSON RESTRICTED TO EAST 75 FEET
- 54 - EP-B-54 CHARLES HARTFIEL MARVELLE HARTFIEL & IDA J. SMITH (PART. EASE REL. 3/8/72)
- 55 - EP-B-55 ELMER D & VIOLA ERICKSON (PART. EASE REL. 4/28/72)
- 56 - EP-B-56 LEONARD E. JOHNSON DORIS JOHNSON (PART. EASE REL. 4/16/72)
- * 58 - EP-B-58 CARL E. & CATHERINE M. SORENSEN
- * 59 - EP-B-59 RICHARD & JANICE KLEVEN, HAROLD R. & ELAINE RUBIN, CARL E. & CATHERINE M. SORENSEN
- 60 - EP-B-60 WALTER J. VOSIKA ILEEN VOSIKA (PART. EASE REL. 4/28/72) RESTRICTS TO W. 50' NW-NW - 35-32-24 DOC# 368469

- * 58 - EP-B-58 RESTRICTED AS WRITTEN TO E. 35' OF NE-NE SEC. 34 & W. 35' SW-NW SEC. 35 DOC# 297578
- * 59 - EP-B-59 PARTIAL RELEASE 5-5-69 RESTRICTS TO EAST 70' SE-NE- 34-32-24 - DOC# 323159

UNITED POWER ASSOCIATION			
ELK RIVER, MINNESOTA			
K. B. MACKICHAN & ASSOCIATES			
Grand Forks, & Minot, N. Dak.		Redwood Falls, Minn.	
"PEX" - ELK RIVER TO PARKWOOD-230 KV. DAYTONPORT TO PARKWOOD-69 KV.			
Date: NOV 9, 1965	Dwn by: JRC DRW	Sta: 550+00	
Scale: Hor. 1"=200'	Appd. by: [Signature]	to Sta: 610+00	
Ver. 1"=20'	W.O. No. 01999		
Voltage: "PE" LINE-230KV			
"EP" LINE-69KV			
By: [Signature]			
Date: [Blank]	REVISION		