

PLAN SYMBOLS

- COUNTY LINE
- TOWNSHIP OR RANGE LINE
- SECTION LINE
- QUARTER LINE
- SIXTEENTH LINE
- RIGHT OF WAY LINE
- SLOPE EASEMENT
- PRESENT RIGHT OF WAY
- PROPERTY LINE
- CORPORATE OR CITY LIMITS
- RETAINING WALL
- RAILROAD
- RAILROAD RIGHT OF WAY
- RIVER OR CREEK
- DRAINAGE DITCH
- CULVERT
- DROP INLET
- GAURO RAIL
- BARBED WIRE FENCE
- WOVEN WIRE FENCE
- CHAIN LINK FENCE
- WOOD FENCE
- STONE WALL OR FENCE
- HEDGE

- LOWLAND
- TIMBER
- ORCHARD
- BRUSH
- NURSERY
- CATTLE GAURD

- OVERPASS (Highway Over)
- UNDERPASS (Highway Under)
- BRIDGE

- BUILDING (One Story Frame)
- F-FRAME C-CONCRETE
- S-STONE T-TILE
- B-BRICK ST-STUCCO

- RAILROAD CROSSING BELL
- RAILROAD CROSSING GATE
- MANHOLE
- CATCH BASIN
- FIRE HYDRANT
- CAST IRON MONUMENT
- IRON PIN
- GRAVEL PIT
- SAND PIT
- BORROW PIT
- ROCK QUARRY

UTILITY SYMBOLS

- POWER POLE LINE
- TELEPHONE OR TELEGRAPH POLE LINE
- JOINT TELEPHONE & POWER ON POWER POLES
- ON TELEPHONE POLES
- ANCHOR
- STEEL TOWER
- STREET LIGHT
- PEDESTAL (Cable Terminal)
- GAS MAIN
- WATERMAIN
- TELEPHONE CABLE IN CONDUIT
- ELECTRIC CABLE IN CONDUIT
- TELEPHONE MANHOLE
- ELECTRIC MANHOLE
- BURIED TELEPHONE CABLE
- BURIED ELECTRIC CABLE
- AERIAL TELEPHONE CABLE
- SEWER (Sanitary or Storm)
- SEWER MANHOLE

SCALES

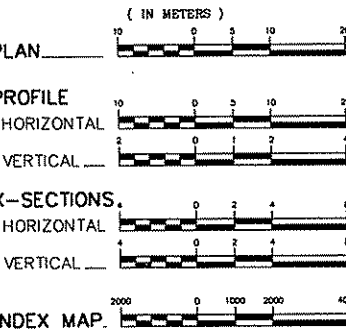

ANOKA COUNTY HIGHWAY DEPARTMENT

CONSTRUCTION PLAN FOR GRADING, DRAINAGE, AGGREGATE BASE, AND BITUMINOUS SURFACING.

LOCATED ON C.S.A.H. 22 BETWEEN THE WEST COUNTY LINE AND C.S.A.H. 83 (Geographic Description)

LOCATED ON C.S.A.H. 83 BETWEEN C.R. 63 AND C.S.A.H. 22 & C.R. 64 (Geographic Description)

C.S.A.H. 22 FROM THE N.W. COR. OF SEC. 6, T32N., R25W. TO A POINT 168.573 m N. OF THE N.1/4 COR. OF SEC. 6, T32N., R25W. (Legal Description)

C.S.A.H. 83 FROM A POINT 121.704 m N. AND 1.394 m E. OF THE S.1/4 COR. OF SEC.6, T32N., R25W. TO THE N.1/4 COR. OF SEC. 6, T32N., R25W. (Legal Description)

CONSTRUCTION

STATE AID PROJ. NO. 02-622-27

GROSS LENGTH	993.600 m	0.994 km
BRIDGES-LENGTH	m	km
EXCEPTIONS-LENGTH	m	km
NET LENGTH	993.600 m	0.994 km

CONSTRUCTION

STATE AID PROJ. NO. 02-683-01

GROSS LENGTH	1485.211 m	1.485 km
BRIDGES-LENGTH	m	km
EXCEPTIONS-LENGTH	m	km
NET LENGTH	1485.211 m	1.485 km

BEG. S.A.P. 02-622-27 STA. 20+000.000 END S.A.P. 02-622-27 STA. 20+993.600

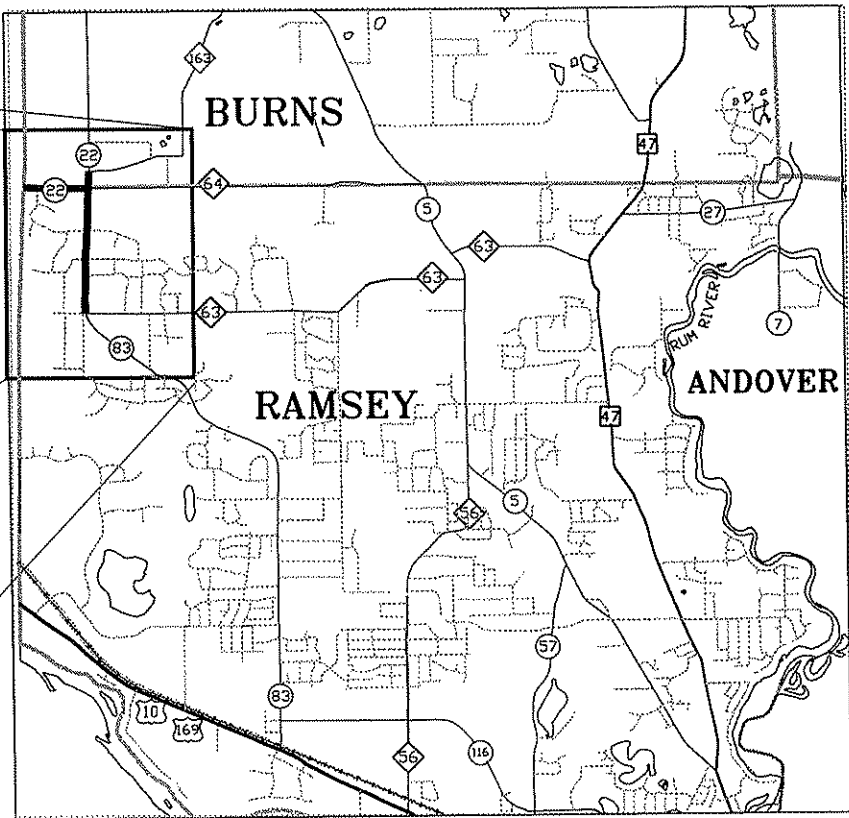
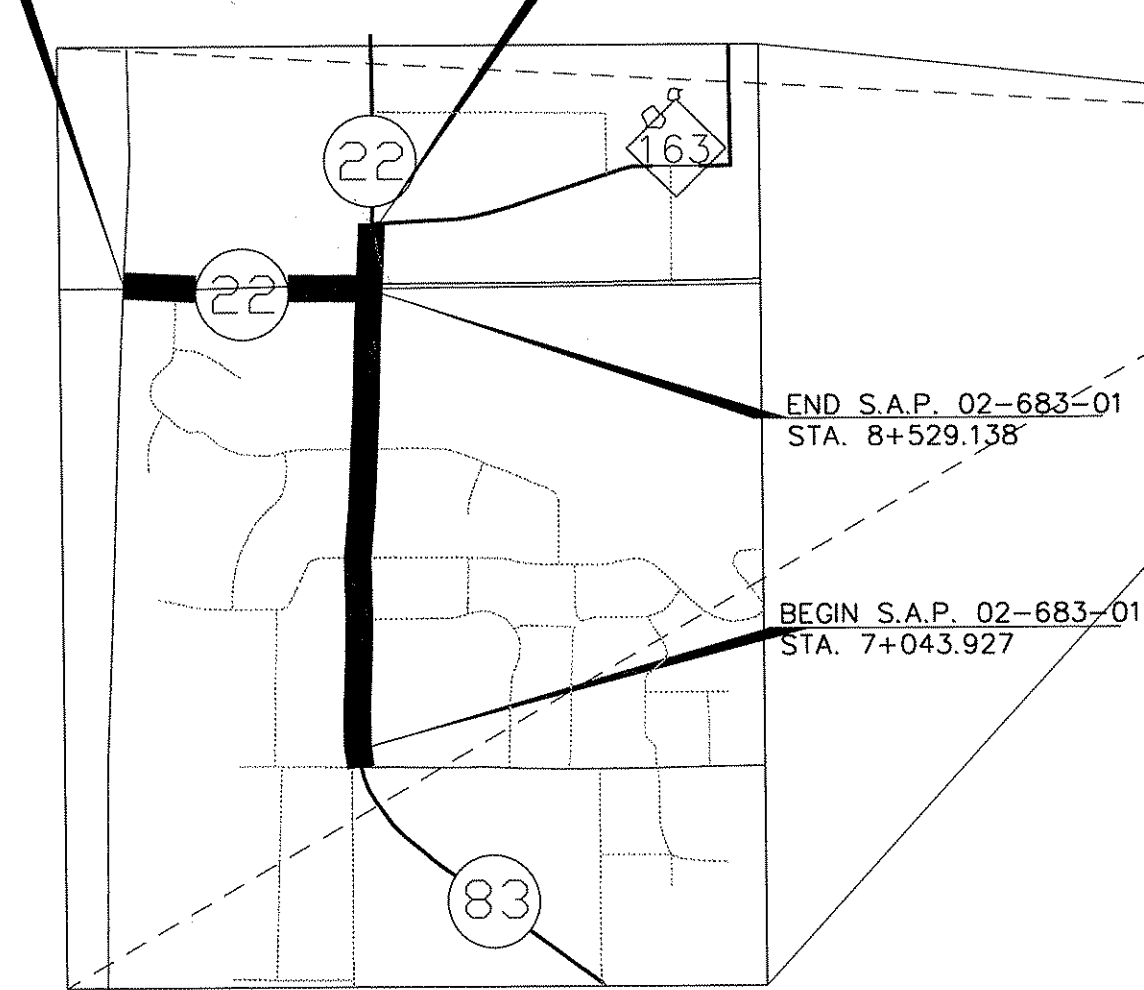

VICINITY MAP

MINN. PROJ. NO. _____
MINN. PROJ. NO. _____

GOVERNING SPECIFICATIONS

THE 1995 EDITION OF THE MINNESOTA DEPARTMENT OF TRANSPORTATION "STANDARD SPECIFICATIONS FOR CONSTRUCTION" SHALL GOVERN. ALL TRAFFIC CONTROL DEVICES SHALL CONFORM TO THE MMUTCD, INCLUDING "FIELD MANUAL FOR TEMPORARY TRAFFIC CONTROL ZONE LAYOUTS APRIL 1998".

INDEX

SHEET NO.	DESCRIPTION
1	TITLE SHEET
2	STATEMENT OF ESTIMATED QUANTITIES
3 - 7	TABULATION CHARTS
8	EARTHWORK SUMMARY & CONSTRUCTION NOTES
9 - 10	EROSION CONTROL DETAILS
11 - 12	TYPICAL SECTIONS
13 - 16	EXISTING CONDITIONS AND REMOVAL PLAN
17	ALIGNMENT PLAN AND ALIGNMENT TABULATION
18	SUPERELEVATION CHARTS
19 - 25	PLAN AND PROFILE
26	CUT & FILL TAB
27 - 47	CROSS-SECTION
48 - 51	DETOUR PLANS
52 - 56	SIGNING / STRIPING

THIS PLAN CONTAINS 56 SHEETS

DESIGN DESIGNATION

S.A.P. 02-622-27

EN18 ₂₀	687 232
R VALUE	65
ADT (2000) =	4 614
Proj. ADT (2020) =	7 382
Proj. HCADT (2020) =	436
Soil Factor	
9.1 METRIC TON DESIGN	
Shoulder Width	2.4 m

DESIGN DESIGNATION

S.A.P. 02-683-01

EN18 ₂₀	434 323
R VALUE	65
ADT (2000) =	2 916
Proj. ADT (2020) =	4 666
Proj. HCADT (2020) =	275
Soil Factor	
9.1 METRIC TON DESIGN	
Shoulder Width	2.4 m

Functional Classification ARTERIAL (LOW DENSITY)

No. of Traffic Lanes 2 No. of Parking Lanes 0

Design Speed 90 km/h

Based on Stopping Sight Distance 170 m

Height of eye 1070 mm Height of object 150 mm

Design Speed not achieved at: N/A

STA. _____ TO STA. _____ MPH _____

Approved 4/12/2000 *[Signature]*
 Approved 5/4/2000 *[Signature]*
 Recommended for Approval *Pat G. Loken* DATE 5-4-2000
 Approved *Pat G. Loken* DATE 5-4-2000

DRAWN BY _____ DATE 12-21-99
 DESIGN BY _____ DATE 12-21-99
 CHECKED BY _____ DATE 12-21-99



**ANOKA COUNTY
HIGHWAY DEPT.**

STATE PROJECT NO. _____
 STATE AID PROJECT NO. 02-622-27
 STATE AID PROJECT NO. 02-683-01
 COUNTY PROJECT NO. _____

TITLE SHEET

Sheet 1 of 56

I HEREBY CERTIFY THAT THIS PLAN WAS PREPARED BY ME OR UNDER MY DIRECT SUPERVISION AND THAT I AM A DULY REGISTERED PROFESSIONAL ENGINEER UNDER THE LAWS OF THE STATE OF MINNESOTA.

[Signature]
 DATE 4/12/00 REG. NO. 25066

APPR 9:57:14 am EST

STATEMENT OF ESTIMATED QUANTITIES

CHART NO.	ITEM NO.	ITEM	UNIT	ANOKA COUNTY		ANOKA COUNTY		ANOKA COUNTY	
				TOTAL		S.A.P. 02-622-27		S.A.P. 02-683-01	
				ESTIMATED	FINAL	ESTIMATED	FINAL	ESTIMATED	FINAL
	2013.601	CELLULAR MOBILE TELEPHONE	LUMP SUM	1		0.3		0.7	
	2015.601	COMPUTER EQUIPMENT	LUMP SUM	1		0.3		0.7	
	2021.501	MOBILIZATION	LUMP SUM	1		0.3		0.7	
	2031.501	FIELD OFFICE TYPE D	EACH	1		0.3		0.7	
A	2101.501	CLEARING	ha	0.38		0.04		0.34	
A	2101.502	CLEARING	TREE	577		39		538	
A	2101.506	GRUBBING	ha	0.38		0.04		0.34	
A	2101.507	GRUBBING	TREE	593		38		555	
1	2104.501	REMOVE FENCE	m	2		2			
2	2104.501	REMOVE PIPE CULVERT	m	203.89		134.10		69.79	
D	2104.503	REMOVE BITUMINOUS PAVEMENT	m2	20459		8052		12407	
B	2104.504	REMOVE CONCRETE PAVEMENT	m2	199				199	
K	2104.509	REMOVE CONCRETE APRON	EACH	1		1			
B	2104.511	SAWING CONCRETE PAVEMENT (FULL DEPTH)	m	14.1				14.1	
G	2104.513	SAWING BITUMINOUS PAVEMENT (FULL DEPTH)	m	172.50		41.70		130.80	
E	2104.521	SALVAGE FENCE	m	510		104		406	
10	2104.523	SALVAGE SIGN TYPE C	EACH	70		37		33	
3	2104.523	SALVAGE SIGN TYPE SPECIAL	EACH	5		2		3	
P	2105.501	COMMON EXCAVATION (EV) (P)	m3	33950		13702		20248	
P	2105.505	MUCK EXCAVATION (EV)	m3	4404		330		4074	
P	2105.521	GRANULAR BORROW (LV)	m3	2138				2138	
11	2105.604	GEOTEXTILE FABRIC	m2	3750				3750	
P	2105.607	EXCAVATION SPECIAL (EV)	m3	1782				1782	
	2123.509	DOZER	HOURL	20		10		10	
4	2130.501	WATER	m3	2350		783		1567	
5	2211.503	AGGREGATE BASE (CV) CLASS 5 (P)	m3	5979		2420		3559	
	2232.501	MILL BITUMINOUS SURFACE	m2	58		29		29	
8	2331.603	SAWED/SEALED JOINT	m	2974		1192		1782	
3	2350.604	TYPE LV 4 WEARING COURSE MIXTURE, 50 mm THICKNESS	m2	837		174		663	
O	2350.609	TYPE MV 4 WEARING COURSE MIXTURE	t	3067		1205		1862	
6	2350.609	TYPE LV 3 NON WEARING COURSE MIXTURE	t	5361		2078		3283	
B	2357.502	BITUMINOUS MATERIAL FOR TACK COAT	L	11812		4555		7257	
	2451.609	GRANULAR FOUNDATION AND/OR BEDDING	t	272.31		184.21		88.10	
2	2501.501	CULVERT EXCAVATION, CLASS U	m3	119.55		64.66		54.89	
K	2501.511	375 mm CS PIPE CULVERT	m	300.70		104.90		195.80	
K	2501.511	450 mm CS PIPE CULVERT	m	87.06		31.56		55.50	
K	2501.511	900 mm CS PIPE CULVERT	m	39.80		15.20		24.60	
K	2501.515	600 mm RC PIPE APRON	EACH	7		2		5	
K	2501.515	900 mm RC PIPE APRON	EACH	2		2			
H	2501.525	725 mm SPAN RC PIPE ARCH APRON	EACH	1				1	
K	2501.561	600 mm RC PIPE CULVERT, DES 3006	m	54.03		23.50		30.53	
K	2501.561	900 mm RC PIPE CULVERT, DES 3006	m	29.26		29.26			
K	2501.567	375 mm CS SAFETY APRON & GRATE, DES 312B	EACH	50		16		34	
K	2501.567	450 mm CS SAFETY APRON & GRATE, DES 312B	EACH	12		4		8	
H	2503.521	725 mm SPAN RC PIPE ARCH SEWER JIA	m	11.89				11.89	
H	2503.541	600 mm RC PIPE SEWER DESIGN 3006	m	8.84				8.84	
H	2506.501	CONSTRUCT DRAINAGE STRUCTURE DESIGN F	m	2.505				2.505	
H	2506.516	CASTING ASSEMBLY	EACH	1				1	
H,K	2511.501	RANDOM RIPRAP, CLASS III	m3	10.5				10.5	
K	2511.501	RANDOM RIPRAP, CLASS IV	m3	14		14			
	2531.507	150 mm CONCRETE DRIVEWAY PAVEMENT	m2	171				171	
F	2540.602	INSTALL MAIL BOX SUPPORT	EACH	24		7		17	
E	2557.603	INSTALL FENCE	m	471		104		367	
	2563.601	DETOUR SIGNING - CSAH 83	LUMP SUM	1				1	
	2563.601	DETOUR SIGNING - CSAH 22	LUMP SUM	1		1			
	2564.531	SIGN PANELS TYPE C	m2	36.313		21.235		15.078	
3	2564.602	INSTALL SIGN TYPE SPECIAL	EACH	5		2		3	
	2564.603	100 mm SOLID LINE WHITE - PAINT	m	4894.725		2392.49		2502.235	
	2564.603	100 mm BROKEN LINE WHITE - PAINT	m	24.384		12.192		12.192	
	2564.603	100 mm SOLID LINE YELLOW - PAINT	m	971.473		344.646		626.827	
	2564.603	100 mm BROKEN LINE YELLOW - PAINT	m	713.777		613.641		100.136	
	2564.603	100 mm DOUBLE SOLID LINE YELLOW - PAINT	m	457.738		318.086		139.652	
9	2573.501	BALE CHECK	EACH	45		15		30	
J	2573.502	SILT FENCE TYPE PREASSEMBLED	m	108				108	
J	2573.502	SILT FENCE TYPE HEAVY DUTY	m	678		281		397	
C	2575.501	SEEDING	ha	3.4		1.2		2.2	
C	2575.502	SEED MIXTURE 70A	kg	171.4		60.2		111.2	
C	2575.505	SODDING TYPE SALT RESISTANT	m2	9556.6		3504.6		6052.0	
C	2575.511	MULCH MATERIAL TYPE 1	t	15.4		5.4		10.0	
C	2575.519	DISK ANCHORING	ha	3.4		1.2		2.2	
7	2575.523	EROSION CONTROL BLANKETS CATEGORY 2	m2	2455.5		2321.5		134.0	
C	2575.532	COMMERCIAL FERTILIZER ANALYSIS 10-10-10	kg	1919.4		674.0		1245.4	

MN/DOT STANDARD PLATES
THESE STANDARD PLATES AS APPROVED BY THE FHWA SHALL APPLY.

PLATE NO.	DESCRIPTION
M3000 L	REINFORCED CONCRETE PIPE
M3006 G	GASKET JOINT FOR R.C. PIPE
M3014 J	REINFORCED CONCRETE PIPE ARCH
M3022 B	PRECAST CONCRETE END SECTIONS
M3040 F	CORRUGATED METAL PIPE CULVERT
M3100 G	CONCRETE APRON FOR REINFORCED CONCRETE PIPE
M3110 G	CONCRETE APRON FOR REINFORCED CONCRETE PIPE-ARCH
M3128 F	SAFETY APRON
M3133 C	RIPRAP AT RCP OULETS
M3145 E	CONCRETE PIPE TIES
M3221 C	CORRUGATED STEEL PIPE COUPLING BAND
M3221 C	CORRUGATED STEEL PIPE COUPLING BAND
M4005 L	MANHOLE OR CATCH BASIN
M4010 H	CONCRETE SHORT CONE AND ADJUSTING RING
M4011 E	PRECAST CONCRETE BASE
M4101 D	RING CASTING FOR MANHOLE OR CATCH BASIN
M4110 F	COVER CASTING FOR MANHOLES
M4180 J	MANHOLE OR CATCH BASIN STEP
M8000 I	STANDARD BARRICADES
M8150 B	INSTALLATION OF CULVERT MARKERS
M9102 D	TURF ESTABLISHMENT AREAS (AT PIPE CULVERT ENDS)

NOTE: IF METRIC STANDARD PLATE IS NOT AVAILABLE CONVERT ENGLISH STANDARD PLATE TO NEAREST 0.0001 m.

INDEX OF TABULATION CHARTS

CHART	SHEET No.	DESCRIPTION
A	3-4	CLEARING AND GRUBBING
B	5	DRIVEWAY CONSTRUCTION
C	5	TURF ESTABLISHMENT
D	5	REMOVE BITUMINOUS PAVEMENT
E	5	FENCE CONSTRUCTION
F	5	MAIL BOX SALVAGE AND INSTALL
G	5	SAWING BITUMINOUS PAVEMENT
H	6	STORM SEWER TABULATION
I	6	CASTING SCHEDULE
J	6	SILT FENCE
K	6	CULVERT TABULATION
L	6-7	PUBLIC UTILITY OWNED BY US WEST
M	7	PUBLIC UTILITY OWNED BY NSP
N	7	PUBLIC UTILITY OWNED BY MINNEGASCO
O	7	PUBLIC UTILITY OWNED BY CITY
P	8	EARTHWORK SUMMARY
Q	8	BASE BITUMINOUS QUANTITIES CHART

BASIS OF PLANNED QUANTITIES

- 2350 TYPE MV 4 WEARING COURSE 2.35 kg/m2/mm THICKNESS
- 2350 TYPE LV 3 NON WEARING COURSE 2.35 kg/m2/mm THICKNESS
- 2357 BITUMINOUS MATERIAL FOR TACK 0.23 L/m2 PER LIFT APPLIED
- 2575 MULCH MATERIAL TYPE 1, 4.5 t/ha
- 2575 COMMERCIAL FERTILIZER, ANALYSIS 10-10-10 (OR EQUIVALENT) 500 kg/ha ON ALL SEED AREAS
- 2575 ROADSIDE SEEDING BASED ON HORIZONTAL MEASUREMENT +10% SEED MIXTURE NO. 70A, 50 kg/ha

NOTES

- INCLUDES ALL TYPES AND SIZES. (INCLUDING APRONS)
- INCLUDES ALL BITUMINOUS PAVEMENTS REGARDLESS OF DEPTH AND WIDTH.
- MUNICIPAL STREET SIGNS.
- FOR DUST CONTROL AS DIRECTED BY THE ENGINEER.
- INCLUDES QUANTITY FOR GRAVEL DRIVEWAYS SEE CHART "C" FOR ENT. DEPTH
- INCLUDES QUANTITY FOR ADDITIONAL 6 mm TO DESIGN PAVEMENT THICKNESS.
- FOR EROSION CONTROL AS SHOWN IN THE PLANS OR AS DIRECTED BY THE ENGINEER.
- JOINTS TO BE PLACED AT 10 m SPACING ACROSS LANES OF TRAFFIC AND EXTEND 0.3 m INTO SHOULDER.
- FOR USE AT CULVERT ENDS AND AS DIRECTED BY THE ENGINEER. SEE STD. PLATE M9102 D.
- SALVAGE TO ANOKA COUNTY HIGHWAY MAINTENANCE.
- TO BE USED AT THE BOTTOM OF THE 900 mm SUBCUT PRIOR TO BACKFILLING SUBCUT EMB.
- FOR CULVERT EXC. TO BE REMOVED PRIOR TO PLACEMENT OF GRANULAR BEDDING.
- FOR BITUMINOUS DRIVEWAY CONSTRUCTION. INCLUDES 100 mm AGGREGATE BASE CLASS 5.
- FOR FILL IN SPECIAL EXCAVATION AREA.

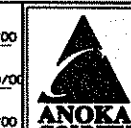
				I HEREBY CERTIFY THAT THIS PLAN WAS PREPARED BY ME OR UNDER MY DIRECT SUPERVISION AND THAT I AM A DULY REGISTERED PROFESSIONAL ENGINEER UNDER THE NAME OF THE STATE OF MINNESOTA.		DRAWN BY: <u>HN</u> DATE: <u>04/20/00</u>		ANOKA COUNTY HIGHWAY DEPT.		STATE PROJECT NO. _____ STATE AID PROJECT NO. <u>02-622-27</u> STATE AID PROJECT NO. <u>02-683-01</u> COUNTY PROJECT NO. _____		STATEMENT OF ESTIMATED QUANTITIES Sheet <u>2</u> of <u>56</u> Sheets	
NO DATE BY CKD APPR REVISION				DATE <u>04/20/00</u> REG. NO. <u>25066</u>		DESIGN BY: <u>KGJ</u> DATE: <u>04/20/00</u>							
02-ESTQUANT.dwg 4-21-00 3:30:20 pm EST						CHECKED BY: <u>LR</u> DATE: <u>04/20/00</u>							

CLEARING AND GRUBBING (A)					
STATION	LOCATION	CLEARING		GRUBBING	
		EACH	ha	EACH	ha
S.A.P. 02-683-01 (C.S.A.H. 83)					
7+750.19	10.67 m LT LSB	1		1	
7+751.32	13.08 m LT LSB	1		1	
7+752.96	10.67 m LT LSB	1		1	
7+753.49	14.26 m LT LSB	1		1	
7+754.16	15.88 m LT LSB	1		1	
7+755.35	12.90 m LT LSB	1		1	
7+755.38	10.67 m LT LSB	1		1	
7+758.14	10.67 m LT LSB	1		1	
7+759.48	14.12 m LT LSB	1		1	
7+760.22	10.67 m LT LSB	1		1	
7+761.08	15.63 m LT LSB	1		1	
7+762.04	12.42 m LT LSB	1		1	
7+762.75	10.67 m LT LSB	1		1	
7+760.45	16.36 m RT LNB	1		1	
7+767.89	17.67 m LT LSR	1		1	
7+783.70	17.67 m LT LSR	1		1	
7+787.15	14.00 m RT LNB	1		1	
7+787.17	15.52 m RT LNB	1		1	
7+789.59	14.00 m RT LNB	1		1	
7+791.52	15.52 m RT LNB	1		1	
7+792.89	14.00 m RT LNB	1		1	
7+794.73	15.52 m RT LNB	1		1	
7+796.37	14.35 m RT LNB	1		1	
7+798.03	15.52 m RT LNB	1		1	
7+799.93	14.00 m RT LNB	1		1	
7+800.92	15.15 m RT LNB	1		1	
7+802.65	14.26 m RT LNB	1		1	
7+802.67	15.48 m RT LNB	1		1	
7+805.19	12.17 m LT LSR	1		1	
7+805.51	15.90 m LT LSR	1		1	
7+805.62	14.08 m LT LSR	1		1	
7+808.38	12.26 m LT LSR	1		1	
7+808.59	15.53 m LT LSR	1		1	
7+810.08	15.55 m LT LSR	1		1	
7+811.29	12.26 m LT LSR	1		1	
7+813.08	14.60 m LT LSR	1		1	
7+813.44	12.56 m LT LSR	1		1	
7+814.83	13.12 m RT LNB	1		1	
7+815.87	15.18 m RT LNB	1		1	
7+816.63	15.89 m LT LSR	1		1	
7+816.67	13.32 m LT LSR	1		1	
7+817.44	13.35 m RT LNB	1		1	
7+817.47	15.18 m RT LNB	1		1	
7+818.01	12.56 m LT LSR	1		1	
7+819.57	15.18 m RT LNB	1		1	
7+820.81	13.35 m RT LNB	1		1	
7+821.04	15.61 m LT LSR	1		1	
7+821.64	13.72 m LT LSR	1		1	
7+821.65	12.56 m LT LSR	1		1	
7+822.02	17.00 m RT LNB	1		1	
7+824.46	18.53 m RT LNB	1		1	
7+824.74	15.18 m RT LNB	1		1	
7+824.90	12.56 m LT LSR	1		1	
7+826.10	15.10 m LT LSR	1		1	
7+826.29	13.35 m RT LNB	1		1	
7+827.12	13.54 m LT LSR	1		1	
7+827.16	15.18 m RT LNB	1		1	
7+827.18	17.00 m RT LNB	1		1	
7+828.67	18.53 m RT LNB	1		1	
7+828.46	12.26 m LT LSR	1		1	
7+829.28	17.00 m RT LNB	1		1	
7+830.52	15.18 m RT LNB	1		1	
7+830.67	15.16 m LT LSR	1		1	
7+830.78	13.25 m LT LSR	1		1	
7+830.87	12.26 m LT LSR	1		1	
7+833.76	13.35 m RT LNB	1		1	
7+834.41	14.80 m LT LSR	1		1	
7+834.85	12.56 m LT LSR	1		1	
7+836.01	17.04 m RT LNB	1		1	
7+836.50	13.35 m RT LNB	1		1	
7+837.37	17.62 m LT LSR	1		1	
7+837.38	16.67 m LT LSR	1		1	
7+837.40	15.64 m LT LSR	1		1	
7+837.74	13.51 m LT LSR	1		1	
7+837.76	11.95 m LT LSR	1		1	
7+837.77	11.06 m LT LSR	1		1	
7+837.78	10.43 m LT LSR	1		1	
7+838.56	13.35 m RT LNB	1		1	
7+839.27	17.17 m LT LSR	1		1	
7+839.28	16.61 m LT LSR	1		1	
7+839.48	13.48 m LT LSR	1		1	
7+839.77	15.67 m LT LSR	1		1	
7+839.78	14.41 m LT LSR	1		1	
7+840.26	15.18 m RT LNB	1		1	
7+840.79	15.84 m LT LSR	1		1	
7+840.76	14.52 m LT LSR	1		1	
7+840.82	13.48 m LT LSR	1		1	
7+842.95	15.18 m RT LNB	1		1	
7+844.28	13.35 m RT LNB	1		1	

CLEARING AND GRUBBING (A)					
STATION	LOCATION	CLEARING		GRUBBING	
		EACH	ha	EACH	ha
S.A.P. 02-683-01 (C.S.A.H. 83)					
7+845.97	13.17 m LT LSR	1		1	
7+846.80	13.35 m RT LNB	1		1	
7+847.58	15.04 m RT LNB	1		1	
7+847.46	15.83 m RT LNB	1		1	
7+847.81	18.22 m RT LNB	1		1	
7+847.83	13.35 m RT LNB	1		1	
7+849.45	16.36 m RT LNB	1		1	
7+850.04	13.35 m RT LNB	1		1	
7+850.77	14.60 m RT LNB	1		1	
7+852.38	17.18 m RT LNB	1		1	
7+852.88	13.35 m RT LNB	1		1	
7+853.06	14.57 m RT LNB	1		1	
7+854.06	18.22 m RT LNB	1		1	
7+855.50	13.60 m RT LNB	1		1	
7+856.33	12.26 m LT LSR	1		1	
7+856.76	13.35 m RT LNB	1		1	
7+856.81	17.05 m RT LNB	1		1	
7+857.96	14.90 m RT LNB	1		1	
7+859.09	16.54 m RT LNB	1		1	
7+859.68	13.35 m RT LNB	1		1	
7+868.13	16.25 m RT LNB	1		1	
7+868.25	14.04 m RT LNB	1		1	
7+868.49	11.80 m RT LNB	1		1	
7+870.46	15.77 m RT LNB	1		1	
7+871.10	13.77 m RT LNB	1		1	
7+872.63	11.78 m RT LNB	1		1	
7+873.73	15.16 m RT LNB	1		1	
7+876.16	13.09 m RT LNB	1		1	
7+876.98	15.23 m RT LNB	1		1	
7+878.22	15.70 m RT LNB	1		1	
7+881.35	13.00 m RT LNB	1		1	
7+881.36	12.26 m RT LNB	1		1	
7+882.77	14.26 m RT LNB	1		1	
7+883.22	16.85 m RT LNB	1		1	
7+885.98	15.17 m RT LNB	1		1	
7+887.71	12.98 m RT LNB	1		1	
7+887.82	16.94 m RT LNB	1		1	
7+888.62	14.89 m RT LNB	1		1	
7+890.35	12.98 m RT LNB	1		1	
7+891.07	15.13 m RT LNB	1		1	
7+892.50	14.63 m RT LNB	1		1	
7+894.19	16.93 m RT LNB	1		1	
7+894.54	12.97 m RT LNB	1		1	
7+896.54	14.98 m RT LNB	1		1	
7+898.86	15.32 m RT LNB	1		1	
7+899.04	12.96 m RT LNB	1		1	
7+901.46	15.40 m RT LNB	1		1	
7+902.92	14.95 m RT LNB	1		1	
7+902.90	14.90 m RT LNB	1		1	
7+904.90	15.70 m RT LNB	1		1	
7+906.01	14.00 m RT LNB	1		1	
7+908.2	12.94 m RT LNB	1		1	
7+908.84	12.40 m LT LSR	1		1	
7+908.91	15.95 m LT LSR	1		1	
7+909.70	18.35 m LT LSR	1		1	
7+910.34	15.45 m LT LSR	1		1	
7+910.50	15.12 m RT LNB	1		1	
7+910.51	15.59 m RT LNB	1		1	
7+911.19	12.87 m LT LSR	1		1	
7+911.78	11.72 m RT LNB	1		1	
7+913.04	14.39 m RT LNB	1		1	
7+914.41	11.72 m RT LNB	1		1	
7+914.47	14.93 m RT LNB	1		1	
7+915.47	14.27 m RT LNB	1		1	
7+917.48	14.76 m RT LNB	1		1	
7+918.13	11.70 m RT LNB	1		1	
7+920.28	14.48 m RT LNB	1		1	
7+922.76	14.82 m RT LNB	1		1	
7+924.65	11.68 m RT LNB	1		1	
7+924.75	16.87 m RT LNB	1		1	
7+926.91	13.78 m RT LNB	1		1	
7+927.79	14.81 m RT LNB	1		1	
7+928.33	12.36 m RT LNB	1		1	
7+928.49	15.66 m RT LNB	1		1	
7+929.76	12.89 m RT LNB	1		1	
7+931.12	15.99 m RT LNB	1		1	
7+931.92	13.68 m RT LNB	1		1	
7+933.50	11.67 m RT LNB	1		1	
7+935.02	13.71 m RT LNB	1		1	
7+935.01	15.24 m RT LNB	1		1	
7+936.87	14.97 m RT LNB	1		1	
7+938.45	12.88 m RT LNB	1		1	
7+939.22	14.35 m RT LNB	1		1	
7+940.78	15.75 m RT LNB	1		1	
7+941.74	14.17 m RT LNB	1		1	
7+941.75	15.33 m RT LNB	1		1	
7+943.4	13.81 m RT LNB	1		1	
7+943.54	15.52 m RT LNB	1		1	
7+946.31	12.96 m RT LNB	1		1	
7+945.39	16.00 m RT LNB	1		1	

CLEARING AND GRUBBING (A)					
STATION	LOCATION	CLEARING		GRUBBING	
		EACH	ha	EACH	ha
S.A.P. 02-683-01 (C.S.A.H. 83)					
7+945.52	14.08 m RT LNB	1		1	
7+957.02	17.00 m RT LNB	1		1	
7+957.94	17.00 m RT LNB	1		1	
7+958.23	16.09 m RT LNB	1		1	
7+959.77	17.00 m RT LNB	1		1	
7+960.68	17.00 m RT LNB	1		1	
7+978.66	17.00 m RT LNB	1		1	
7+987.77	13.96 m RT LNB	1		1	
8+021.63	18.29 m RT LNB	1		1	
8+027.12	18.05 m LT LSR	1		1	
8+028.88	11.00 m LT LSR	1		1	
8+036.65	16.31 m RT LNB	1		1	
8+044.22	17.68 m LT LSR	1		1	
8+048.82	18.29 m RT LNB	1		1	
8+065.96	17.31 m RT LNB	1		1	
8+095.90	18.36 m LT LSR	1		1	
8+121.07	13.20 m LT LSR	4		4	
8+128.81	12.75 m LT LSR	1		1	
8+128.39	14.38 m LT LSR	1		1	
8+128.84	14.27 m LT LSR	1		1	
8+129.29	13.30 m LT LSR	1		1	
8+412.40	9.75 m LT LSR	1		1	
8+416.25	13.70 m LT LSR	1		1	
7+425.19	10.41 m LT LSR	1		1	
8+430.63	15.59 m LT LSR	1		1	
8+436.45	13.71 m LT LSR	1		1	
8+443.58	18.63 m LT LSR	1		1	
8+444.38	14.49 m LT LSR	1		1	
8+446.72	18.88 m LT LSR	1		1	
SUBTOTAL		538	0.338	555	0.338

CLEARING AND GRUBBING (A)					
STATION	LOCATION	CLEARING		GRUBBING	
		EACH	ha	EACH	ha
S.A.P. 02-622-27 (C.S.A.H. 22)					
20+000.00	11.60 m RT CL		0.0025		0.0025
20+007.10	16.62 m RT CL	1		1	
20+010.62	16.87 m RT CL	1		1	
20+013.03	15.39 m RT CL	1		1	
20+015.03	17.52 m RT CL	1		1	
20+019.15	17.46 m RT CL	1		1	
20+023.14	18.17 m RT CL	1		1	
20+026.57	18.25 m RT CL	1		1	
20+071.40	13.28 m RT CL	1		1	
20+072.23	12.36 m RT CL	1		1	
20+073.76	12.74 m RT CL	3		3	
20+076.55	12.88 m RT CL	4		4	
20+081.02	13.12 m RT CL	1	</		

CLEARING AND GRUBBING (A)

STATION	LOCATION	CLEARING		GRUBBING	
		EACH	ha	EACH	ha
7+109.46-7+148.66	10.47-17.97 m RT LNB		0.046		0.046
7+113.72-7+125.31	18.85-7.93 m LT LNB		0.026		0.026
7+128.97-7+165.10	18.81-8.06 m LT LNB		0.056		0.056
7+146.48	12.47 m RT LNB	1		1	
7+153.49	10.95 m RT LNB	1		1	
7+162.40	10.94 m RT LNB	1		1	
7+169.34-7+192.24	8.13-18.28 m LT LNB		0.038		0.038
7+199.14	10.01 m LT LNB	1		1	
7+200.47	15.53 m LT LNB	1		1	
7+204.44	15.86 m LT LNB	1		1	
7+205.75	10.12 m LT LNB	1		1	
7+205.77	8.28 m LT LNB	1		1	
7+206.48	13.93 m LT LNB	1		1	
7+207.17	8.68 m LT LNB	1		1	
7+207.68	9.83 m LT LNB	1		1	
7+208.00	7.56 m LT LNB	1		1	
7+208.37	8.84 m LT LNB	1		1	
7+208.91	12.18 m LT LNB	1		1	
7+209.53	9.72 m LT LNB	1		1	
7+209.67	16.40 m RT LNB	1		1	
7+209.85	8.66 m LT LNB	1		1	
7+210.27	12.36 m LT LNB	1		1	
7+211.54	14.90 m LT LNB	1		1	
7+214.58	10.80 m LT LNB	1		1	
7+224.75	18.23 m RT LNB	1		1	
7+226.24-7+242.22	18.29m-6.61m LT LNB		0.028		0.028
7+226.68	18.28 m RT LNB	1		1	
7+228.24	18.20 m RT LNB	1		1	
7+230.24	18.20 m RT LNB	1		1	
7+231.92	18.20 m RT LNB	1		1	
7+233.59	18.20 m RT LNB	1		1	
7+234.71	18.20 m RT LNB	1		1	
7+236.27	18.20 m RT LNB	1		1	
7+237.72	18.20 m RT LNB	1		1	
7+239.06	18.20 m RT LNB	1		1	
7+240.73	18.20 m RT LNB	1		1	
7+242.52	18.20 m RT LNB	1		1	
7+244.08	18.20 m RT LNB	1		1	
7+245.27-7+259.67	18.29m-6.22m LT LNB		0.046		0.046
7+245.53	18.20 m RT LNB	1		1	
7+246.98	18.20 m RT LNB	1		1	
7+248.54	18.20 m RT LNB	1		1	
7+265.63	15.24 m RT LNB	1		1	
7+272.14	17.01 m RT LNB	1		1	
7+273.26-7+307.94	18.29m-8.44m LT LNB		0.064		0.064
7+311.75-7+329.03	18.29m-8.38m LT LNB		0.034		0.034
7+338.20	10.73 m LT LNB	1		1	
7+346.57	17.47 m RT LNB	1		1	
7+348.32	11.03 m LT LNB	1		1	
7+352.92	8.76 m LT LNB	1		1	
7+354.40	9.20 m LT LNB	1		1	
7+355.90	9.20 m LT LNB	1		1	
7+356.02	17.47 m RT LNB	1		1	
7+357.50	8.12 m LT LNB	1		1	
7+359.39	12.63 m LT LNB	1		1	
7+359.55	10.07 m LT LNB	1		1	
7+359.41	15.68 m LT LNB	1		1	
7+361.79	10.46 m LT LNB	1		1	
7+362.42	11.62 m LT LNB	1		1	
7+363.74	10.42 m LT LNB	1		1	
7+364.36	11.62 m LT LNB	1		1	
7+365.99	10.42 m LT LNB	1		1	
7+367.46	11.10 m LT LNB	1		1	
7+368.30	10.42 m LT LNB	1		1	
7+369.35	11.11 m LT LNB	1		1	
7+367.47	10.42 m LT LNB	1		1	
7+372.09	11.11 m LT LNB	1		1	
7+372.52	10.42 m LT LNB	1		1	
7+373.24	16.52 m LT LNB	1		1	
7+373.92	11.08 m LT LNB	1		1	
7+374.69	10.12 m LT LNB	1		1	
7+374.71	16.52 m LT LNB	1		1	
7+376.23	10.12 m LT LNB	1		1	
7+376.78	15.44 m RT LNB	1		1	
7+377.88	10.42 m LT LNB	1		1	
7+380.19	10.42 m LT LNB	1		1	
7+382.09	10.44 m LT LNB	1		1	
7+382.52	11.15 m LT LNB	1		1	
7+384.15	10.42 m LT LNB	1		1	
7+384.02	11.02 m LT LNB	1		1	
7+386.32	10.42 m LT LNB	1		1	
7+387.06	18.32 m RT LNB	1		1	
7+388.49	10.42 m LT LNB	1		1	
7+390.54	10.42 m LT LNB	1		1	
7+391.07	10.47 m LT LNB	1		1	
7+394.89	10.42 m LT LNB	1		1	
7+395.58	10.53 m LT LNB	1		1	
7+397.19	10.42 m LT LNB	1		1	
7+399.36	10.42 m LT LNB	1		1	

CLEARING AND GRUBBING (A)

STATION	LOCATION	CLEARING		GRUBBING	
		EACH	ha	EACH	ha
7+401.53	10.42 m LT LNB	1		1	
7+402.10	11.11 m LT LNB	1		1	
7+403.71	10.42 m LT LNB	1		1	
7+405.88	10.42 m LT LNB	1		1	
7+407.48	15.92 m RT LNB	1		1	
7+407.24	10.35 m LT LNB	1		1	
7+408.20	10.44 m LT LNB	1		1	
7+408.11	17.04 m RT LNB	1		1	
7+409.84	15.18 m RT LNB	1		1	
7+410.10	10.12 m LT LNB	1		1	
7+410.10	10.78 m LT LNB	1		1	
7+411.43	18.04 m RT LNB	1		1	
7+412.00	15.18 m RT LNB	1		1	
7+412.40	10.92 m LT LNB	1		1	
7+413.22	10.92 m LT LNB	1		1	
7+413.75	18.04 m RT LNB	1		1	
7+413.97	15.18 m RT LNB	1		1	
7+414.66	10.42 m LT LNB	1		1	
7+414.96	15.18 m RT LNB	1		1	
7+414.64	11.95 m LT LNB	1		1	
7+414.42	13.42 m LT LNB	1		1	
7+414.60	14.65 m LT LNB	1		1	
7+416.20	10.42 m LT LNB	1		1	
7+417.00	12.81 m LT LNB	1		1	
7+416.98	14.31 m LT LNB	1		1	
7+417.57	10.42 m LT LNB	1		1	
7+417.98	12.47 m LT LNB	1		1	
7+419.01	14.16 m LT LNB	1		1	
7+419.84	12.43 m LT LNB	1		1	
7+420.50	10.34 m LT LNB	1		1	
7+420.89	12.57 m LT LNB	1		1	
7+420.74	14.43 m LT LNB	1		1	
7+421.60	10.42 m LT LNB	1		1	
7+421.68	14.78 m LT LNB	1		1	
7+422.57	12.41 m LT LNB	1		1	
7+422.96	10.42 m LT LNB	1		1	
7+415.44	17.93 m RT LNB	1		1	
7+428.40	16.37 m LT LNB	1		1	
7+432.69	17.84 m LT LNB	1		1	
7+433.98	10.42 m LT LNB	1		1	
7+436.50	10.08 m LT LNB	1		1	
7+439.12	9.26 m LT LNB	1		1	
7+440.43	9.50 m LT LNB	1		1	
7+446.43	9.81 m LT LNB	1		1	
7+448.19	11.03 m LT LNB	1		1	
7+457.12	10.52 m LT LNB	1		1	
7+457.16	13.45 m LT LNB	1		1	
7+460.08	12.20 m LT LNB	1		1	
7+461.67	9.81 m LT LNB	1		1	
7+462.80	12.25 m LT LNB	1		1	
7+464.11	9.45 m LT LNB	1		1	
7+468.20	9.83 m LT LNB	1		1	
7+469.67	1.86 m LT LNB	1		1	
7+470.40	9.81 m LT LNB	1		1	
7+471.55	9.81 m LT LNB	1		1	
7+472.96	9.81 m LT LNB	1		1	
7+474.29	9.81 m LT LNB	1		1	
7+475.58	10.32 m LT LNB	1		1	
7+475.76	12.86 m LT LNB	1		1	
7+477.02	9.81 m LT LNB	1		1	
7+478.34	9.81 m LT LNB	1		1	
7+478.51	12.86 m LT LNB	1		1	
7+479.48	9.81 m LT LNB	1		1	
7+481.25	9.81 m LT LNB	1		1	
7+482.93	9.51 m LT LNB	1		1	
7+482.46	11.36 m LT LNB	1		1	
7+483.31	12.33 m LT LNB	1		1	
7+483.93	13.58 m LT LNB	1		1	
7+484.40	13.76 m LT LNB	1		1	
7+484.75	11.83 m LT LNB	1		1	
7+486.10	9.81 m LT LNB	1		1	
7+486.43	11.06 m LT LNB	1		1	
7+486.92	14.50 m LT LNB	1		1	
7+487.69	9.81 m LT LNB	1		1	
7+487.67	10.99 m LT LNB	1		1	
7+488.16	13.55 m LT LNB	1		1	
7+489.01	9.81 m LT LNB	1		1	
7+490.82	12.88 m LT LNB	1		1	
7+491.23	14.74 m LT LNB	1		1	
7+491.46	10.95 m LT LNB	1		1	
7+492.19	9.69 m LT LNB	1		1	
7+492.88	10.53 m LT LNB	1		1	
7+493.51	15.65 m LT LNB	1		1	
7+494.29	10.46 m LT LNB	1		1	
7+494.42	14.16 m LT LNB	1		1	
7+495.31	12.30 m LT LNB	1		1	
7+495.88	9.90 m LT LNB	1		1	
7+496.28	13.48 m LT LNB	1		1	
7+497.09	11.64 m LT LNB	1		1	
7+497.74	9.54 m LT LNB	1		1	

CLEARING AND GRUBBING (A)

STATION	LOCATION	CLEARING		GRUBBING	
		EACH	ha	EACH	ha
7+501.00	9.81 m LT LNB	1		1	
7+501.88	9.81 m LT LNB	1		1	
7+502.94	9.81 m LT LNB	1		1	
7+504.35	9.81 m LT LNB	1		1	
7+505.50	9.81 m LT LNB	1		1	
7+506.28	10.12 m LT LNB	1		1	
7+507.52	10.12 m LT LNB	1		1	
7+509.64	9.81 m LT LNB	1		1	
7+511.14	9.81 m LT LNB	1		1	
7+512.46	9.81 m LT LNB	1		1	
7+515.37	9.81 m LT LNB	1		1	
7+517.13	10.12 m LT LNB	1		1	
7+518.63	10.12 m LT LNB	1		1	
7+520.12	10.12 m LT LNB	1		1	
7+521.36	10.12 m LT LNB	1		1	

DRIVEWAY CONSTRUCTION (B)

STATION	ADDRESS	LOCATION	DESCRIPTION	SAWCUT		REMOVALS				REPLACEMENT					
				BIT. m	CONC. m	LENGTH m	WIDTH m	BIT. m ²	CONC. m ²	GRAVEL m ²	LENGTH m	WIDTH m	50 mm BIT. m ²	150 mm CONC. m ²	150 mm GRAVEL m ²
S.A.P. 02-622-27 (C.S.A.H. 22)															
20+032.50	9560	3.60 RT CL	GRAVEL			3.22	11.57			53.45	3.60	11.00		7.55	
20+049.92		3.60 LT CL	GRAVEL			3.20	15.87			53.48	3.60	11.00		7.55	
20+166.20		3.60 LT CL	GRAVEL			3.26	19.42			70.70	3.60	11.00		7.55	
20+286.30	9430	3.60 RT CL	BITUMINOUS	5.00		5.00	10.33	67.00		5.00	11.10	66.30			
20+341.85	9420	3.60 RT CL	BITUMINOUS	4.68		4.68	10.52	60.37		4.68	11.90	61.90			
20+490.10	9390	3.60 RT CL	GRAVEL			3.60	13.45			73.96	3.60	12.20		7.98	
20+415.12		3.60 RT CL	GRAVEL			3.45	10.78			58.91	3.60	11.00		7.55	
20+436.00		3.60 LT CL	GRAVEL			3.45	15.54			46.62	3.60	11.00		7.55	
20+505.75	9440	3.6 LT CL	BITUMINOUS	3.30		3.30	15.20	109.3		3.60	11.00	50.33			
20+521.83	9360	3.6 RT CL	GRAVEL			3.06	11.55			65.20	3.60	11.00		7.55	
SUBTOTAL				12.98				236.67		422.32			178.53	53.28	
S.A.P. 02-683-01 (C.S.A.H. 83)															
7+126.10	17400	2.50 LT CL	BITUMINOUS	3.70		3.70	12.85	60.95		10.39	3.60	57.39			
7+166.00	17400	2.50 LT CL	BITUMINOUS	4.50		4.50	16.10	72.45		10.39	4.50	66.78			
7+184.90		4.60 RT CL	BITUMINOUS	3.10		3.10	13.60	30.57				52.37			
7+193.50	17410	2.20 LT CL	GRAVEL			3.10	16.30			50.53	10.29	3.10		4.67	
7+226.00	17410	1.90 LT CL	BITUMINOUS	3.00		3.00	16.50	49.50		10.29	3.60	47.77			
7+243.00	17450	2.00 LT CL	GRAVEL			2.90	16.50			47.85	10.29	3.60			
7+255.50		4.80 RT CL	BITUMINOUS	2.90		2.90	13.50	39.15		10.29	3.60	47.77			
7+271.00	17450	1.80 LT CL	GRAVEL			3.00	16.60			49.80	10.27	3.00		7.16	
7+309.10	17450	1.60 LT CL	GRAVEL			3.00	16.80								
7+332.20	17500	1.80 LT CL	BITUMINOUS	3.00		3.00	16.60	49.80		10.29	3.60	47.77			
7+338.30	17501	4.70 RT CL	BITUMINOUS	3.60		3.60	13.70	51.83							
7+360.60	17501	4.90 RT CL	BITUMINOUS	4.70		4.70	13.40	62.98		9.08	4.70	51.96			
7+392.60	17510	1.80 LT CL	BITUMINOUS	3.00		3.00	16.60	49.80		9.13	3.60	43.54			
7+452.60	17520	1.80 LT CL	BITUMINOUS	4.80		4.80	16.70	80.16		9.12	4.80	54.98			
7+507.30		5.10 RT CL	CONCRETE		4.70	4.70	13.20		62.04	9.09	4.70	51.28			
7+658.80		5.00 RT CL	CONCRETE		3.10	3.10	13.20		40.92	10.29	3.10	47.77			
7+725.00		4.75 RT CL	BITUMINOUS			3.60	13.40	54.40		10.29	3.60	48.36			
7+790.50		1.80 LT CL	BITUMINOUS	3.00		3.00	16.70	50.10		10.29	3.60	48.05			
7+806.50	17725	4.30 RT CL	BITUMINOUS	3.60		3.60	14.20	51.12		10.29	4.30	48.34			
7+866.40		2.30 LT CL	BITUMINOUS	3.40		3.40	16.20	55.08		10.29	3.60	48.04		6.64	
8+124.50	17940	1.80 LT CL	GRAVEL			3.50	16.80			58.80	9.09	3.50			
8+285.40		5.70 RT CL	GRAVEL			4.30	12.80		95.50	55.04	12.22	4.30		7.81	
8+367.00		5.60 LT CL	CONCRETE		4.30	4.30	12.80			12.25	4.30			72.32	
8+404.10	18030	5.70 LT CL	GRAVEL			3.60	12.50			48.50	6.94	3.80		3.81	
8+408.50		1.30 RT CL	GRAVEL			3.80	17.00			64.60					
SUBTOTAL				49.90	14.05			808.34	199.46	375.12			663.12	171.37	30.09
UNADJUSTED TOTAL				62.88	14.05			1045.01	199.46	797.44			841.65	171.37	83.37
ADJUSTED TOTAL				63.00	14.10			1045.00	199.00	797.00			842.00	171.00	83.37

TURF ESTABLISHMENT (C)

STA. TO STA.	LOCATION	SOD m ²	SEEDING ha	SEED kg	TYPE-1 MULCH t	DISK ANCHORING ha	FIBER BLANKET m ²	FERTILIZER kg
S. A. P. 02-622-27 (C. S. A. H. 22)								
20+000.00 - 20+092.80	LT CL		0.132	6.62	0.596	0.132		74.18
20+092.80 - 20+200.00	LT CL						1286.40	
20+200.00 - 20+415.10	LT CL		0.234	11.68	1.051	0.234		130.81
20+415.10 - 20+539.00	LT CL	1243.30						
20+539.10 - 20+841.84	LT CL		0.237	11.87	1.068	0.237		132.92
20+841.84 - 20+993.60	LT CL		0.162	8.12	0.731	0.162		90.92
20+000.00 - 20+050.20	RT CL	448.40						
20+050.20 - 20+165.60	RT CL						878.10	
20+165.60 - 20+230.00	RT CL		0.047	2.35	0.212	0.047		26.33
20+230.00 - 20+430.46	RT CL	1621.92						
20+430.46 - 20+823.93	RT CL		0.335	16.76	1.509	0.335		187.73
20+834.20 - 20+865.00	RT CL	145.98						
20+865.00 - 20+993.60	RT CL		0.055	2.77	0.250	0.055		31.05
SUB TOTAL		3459.60	1.203	60.17	5.416	1.203	2164.50	673.95
S. A. P. 02-683-01 (C. S. A. H. 83)								
7+043.65 - 7+325.55	RT CL		0.272	13.6	1.224	0.272		152.32
7+044.59 - 7+325.15	LT CL		0.257	12.85	1.157	0.257		143.92
7+325.55 - 7+404.54	RT CL	755.9						
7+325.15 - 7+481.13	LT CL	1426.35						
7+404.54 - 7+481.29	RT CL		0.060	3.00	0.270	0.060		33.6
7+481.13 - 7+764.74	LT CL		0.251	12.55	1.130	0.251		140.56
7+481.29 - 7+545.68	RT CL	587.06						
7+545.68 - 7+624.77	RT CL		0.070	3.50	0.315	0.070		39.2
7+624.77 - 7+692.95	RT CL	616.23						
7+692.95 - 7+950.00	RT CL		0.236	11.8	1.062	0.236		132.16
7+764.74 - 7+912.65	LT CL	1452.85						
7+912.65 - 7+995.57	LT CL		0.095	4.75	0.428	0.095		53.2
7+950.00 - 8+002.16	RT CL	487.97						
8+002.16 - 8+524.11	RT CL		0.477	23.85	2.147	0.477		267.12
8+002.95 - 8+389.05	LT CL		0.436	21.8	1.962	0.436		244.16
8+389.05 - 8+448.28	LT CL	577.60						
8+448.28 - 8+512.44	LT CL		0.070	3.50	0.315	0.070		39.2
SUB TOTAL		5903.96	2.224	111.2	10.010	2.224	2164.50	1245.44
TOTAL		9363.56	3.427	171.37	15.426	3.427	2164.50	1919.39

FENCE CONSTRUCTION (E)

STATION - STATION	LOC.	REMARKS	REMOVAL m	SALVAGE m	INSTALL m
S.A.P. 02-622-27 (C.S.A.H. 22)					
20+064.10	16.42 RT CL		1.87		
20+064.10 - 20+168.10	16.42 RT CL			103.75	103.75
SUBTOTAL			1.87	103.75	103.75
S.A.P. 02-683-01 (C.S.A.H. 83)					
7+103.46 - 7+175.42	13.29-18.19 RT CL	BARBED WIRE		72.17	72.17
7+109.46 - 7+125.30	11.42-11.98 LT CL	WOVEN WIRE		11.90	11.90
7+326.00 - 7+337.28	11.52-11.52 RT CL	WOOD		11.28	11.28
7+340.94 - 7+359.14	11.52-11.52 RT CL	WOOD		18.20	18.20
7+363.71 - 7+376.38	11.52-10.91 RT CL	WOOD		12.73	12.73
7+376.38 - 7+419.92	10.91-10.91 RT CL	NO FENCE			
7+463.50 - 7+498.24	9.82- 9.92 LT CL	WOVEN WIRE		34.74	34.74
7+541.74 - 7+585.82	18.29-10.12 LT CL	WOVEN WIRE		60.33	44.00
7+638.29 - 7+738.86	18.29-10.12 LT CL	WOVEN WIRE		117.76	101.14
7+731.72 - 7+772.72	18.29-16.40 RT LC	BARBED WIRE		42.89	40.99
7+859.82 - 7+879.78	18.29-16.25 RT LC	WIRE		23.91	19.98
SUBTOTAL				405.91	367.13
TOTAL			1.87	509.66	470.88

SAWING BITUMINOUS PAVEMENT (G)

STATION TO STATION	LOCATION	DESCRIPTION	m
S.A.P. 02-622-27 (C.S.A.H. 22)			
20+000.00	3.22 LT. & RT. CL	MAIN ROAD	6.44
20+198.22	17.20 RT. CL	ERMINE BLVD. NW	7.46
20+830.65	21.60 RT. CL	C. ROAD. 64	7.57
20+993.60	3.22 LT & RT. CL	MAIN ROAD	7.25
20+000.00 - 20+993.60	LT. & RT. CL	BIT. ENTRANCES (SEE CHART B)	12.98
SUBTOTAL			41.70
S.A.P. 02-683-01 (C.S.A.H. 83)			
7+043.93	14.99 LT. & RT. CL	MAIN ROAD	14.50
7+428.00	3.50 RT. CL	175 LN. NW	7.00
7+630.00	3.66 RT. CL	176 AVE. NW	7.32
7+630.00	3.72 RT. CL	176 AVE. NW	7.45
8+800.00	3.66 LT. CL	ERMINE BLVD.	7.32
8+008.00	3.66 RT. CL	178 ST. NW	7.32
8+529.14	14.99 LT. & RT. CL	INTERSECTION C.S.A.H. 22 & 83	29.99
7+043.93 - 8+529.14	LT. & RT. CL	BIT. ENTRANCES (SEE CHART B)	49.90
SUBTOTAL			130.80
TOTAL			172.50

REMOVE BITUMINOUS PAVEMENT (D)

STATION TO STATION	LOCATION	DESCRIPTION	m ²
S.A.P. 02-622-27 (C.S.A.H. 22)			
20+000.00 - 20+100.00	3.60 LT. & RT. CL	MAINLINE	744.53
20+100.00 - 20+420.00	3.60 LT. & RT. CL	MAINLINE	2377.68
20+420.00 - 20+700.00	3.60 LT. & RT. CL	MAINLINE	2092.60
20+700.00 - 20+818.00	3.60 LT. & RT. CL	MAINLINE	898.60
20+845.50 - 20+993.60			

STORM SEWER TABULATION

STRUCT.	STA.	LOC.	REMARKS	MH/CB	DESIGN	PAY HT. m	TOP OF CASTING ELEVATION	OUTLET ELEVATION	FURNISH & INSTALL SEWER PIPE			APRON EACH	DRAINS TO	GRADE IN%	EROSION BLANKET m2	RANDOM RIPRAP CLASS III m3
									CASTING ASSEMBLY	725mm SPAN R.C.P.A. m	600mm R.C.P. m					
1	8+210.000	LT.	APRON INLET		APRON		275.399					1	2			
2	8+210.000	C/L		M.H.	F	2.505	276.379	273.496	A	11.89			3	5.00		
3	8+210.000	RT.	APRON OUTLET		APRON			273.443				1	OUTLET	0.50		4.2
TOTAL						2.505			1	11.89	8.84	2			11	4.2

(H)

SILT FENCE CONSTRUCTION

STA. - STA.	LOCATION	PRE-ASSEMBLED	HEAVY DUTY
S.A.P. 02-622-27 (C.S.A.H. 22)			
20+053.00 - 20+182.00	RT.		129
20+008.00 - 20+160.00	LT.		152
TOTAL			281
S.A.P. 02-683-01 (C.S.A.H. 83)			
7+045 - 7+135	RT.		94
7+045 - 7+152	LT.	108	
8+098 - 8+401	RT.		303
TOTAL		108	397
PROJECT TOTAL =		108	678

(J)

CASTING SCHEDULE

ASS'Y TYPE	NO. REQ'D.	FRAME CASTING	GRATE CASTING	CURB BOX CASTING	RING CASTING	COVER CASTING
A	1				700-7	716
TOTAL		1				

(I)

OWNED BY U.S. WEST TELEPHONE COMPANY

STATION	LOCATION	ITEM	NO.
S.A.P. 02-622-27 (C.S.A.H. 22)			
20+044.9	17.9 m RT CL	SPLICE BOX TELEPHONE	1
20+081.9	12.4 m RT CL	SPLICE BOX TELEPHONE	1
20+190.1	20.6 m RT CL	SPLICE BOX TELEPHONE	1
20+190.5	19.5 m RT CL	SPLICE BOX TELEPHONE	1
20+257.6	14.7 m RT CL	SPLICE BOX TELEPHONE	1
20+360.1	14.7 m RT CL	SPLICE BOX TELEPHONE	1
20+490.3	8.3 m LT CL	SPLICE BOX TELEPHONE	1
20+514.7	17.8 m RT CL	SPLICE BOX TELEPHONE	1
20+803.9	13.1 m RT CL	SPLICE BOX TELEPHONE	1
20+816.0	9.5 m RT CL	SPLICE BOX TELEPHONE	1
20+816.2	9.9 m RT CL	SPLICE BOX TELEPHONE	1
S.A.P. 02-683-01 (C.S.A.H. 83)			
6+915.2	17.2 m LT CL	SPLICE BOX TELEPHONE	1
6+976.2	1.8 m RT CL	SPLICE BOX TELEPHONE	1
7+262.0	11.3 m RT CL	SPLICE BOX TELEPHONE	1
7+415.3	8.5 m RT CL	SPLICE BOX TELEPHONE	1
7+639.9	10.1 m RT CL	SPLICE BOX TELEPHONE	1
7+640.0	9.7 m RT CL	SPLICE BOX TELEPHONE	1
7+640.8	8.2 m RT CL	SPLICE BOX TELEPHONE	1
7+671.7	10.7 m RT CL	SPLICE BOX TELEPHONE	1
7+814.6	10.7 m RT CL	SPLICE BOX TELEPHONE	1
7+932.7	10.9 m RT CL	SPLICE BOX TELEPHONE	1
8+017.8	18.3 m RT CL	SPLICE BOX TELEPHONE	1
8+127.9	12.2 m RT CL	SPLICE BOX TELEPHONE	1
8+133.0	11.0 m LT CL	SPLICE BOX TELEPHONE	1
8+223.3	10.4 m RT CL	SPLICE BOX TELEPHONE	1
8+223.4	12.5 m RT CL	SPLICE BOX TELEPHONE	1
8+521.7	26.8 m LT CL	SPLICE BOX TELEPHONE	1
8+524.9	14.4 m LT CL	SPLICE BOX TELEPHONE	1
8+525.2	14.7 m LT CL	SPLICE BOX TELEPHONE	1
8+525.5	15.8 m RT CL	SPLICE BOX TELEPHONE	1
			30

CULVERT TABULATION

STATION	LOC	INPLACE	REMARKS	REMOVE		FURNISH AND INSTALL												EROSION BLANKET m2	SOD m2	RANDOM RIPRAP CL-III m3	RANDOM RIPRAP CL-IV m3
				CM PIPE m	RC PIPE m	INLET ELEV.	OUTLET ELEV.	375 mm CMP m	450 mm CMP m	600 mm RCP m	900 mm RCP m	900 mm RCP m	AP.	AP.	AP.	AP.					
S. A. P. 02-622-27 (C. S. A. H. 22)																					
20+032.50	RT.	375 mm CMP	GRAVEL ENTRANCE	8.40		273.349	273.398	12.80	2								15.00				
20+050.00	LT.	375 mm CMP	GRAVEL ENTRANCE	7.80		271.300	271.443					15.20	2				18.00				
20+092.50	CL	900 mm CMP	C/L PIPE CROSSING	27.90		271.100	270.925								29.26	2	24.00		14.00		
20+166.20	LT.	375 mm CMP	GRAVEL ENTRANCE	9.35		273.446	273.047	11.00	2								15.00				
20+198.20	RT.		ERMINE BLVD. NW			274.642	274.306			16.36	2						18.00				
20+286.30	RT.	375 mm CMP	BITUMINOUS ENTRANCE	9.30		276.379	276.058	16.50	2								15.00				
20+341.85	RT.	375 mm CMP	BITUMINOUS ENTRANCE	9.30		277.409	277.185	14.00	2								15.00				
20+415.10	RT.	375 mm CMP	GRAVEL ENTRANCE	9.35		277.982	277.964	0.00									15.00				
20+436.00	LT.	375 mm CMP	NO CULV. REQUIRED	9.30																	
20+490.10	RT.	375 mm CMP	BITUMINOUS ENTRANCE	9.30		277.937	277.945	12.80	2								15.00				
20+505.75	RT.	375 mm CMP	GRAVEL ENTRANCE	9.20		277.886	277.943	14.00	2												
20+521.70	RT.	375 mm CMP	GRAVEL ENTRANCE	9.20		277.826	277.877	12.80	2												
20+807.00	CL	600 mm RCP	C/L PIPE CROSSING	15.70		276.445	276.386	11.00	2							18.90	2	15.00			
20+953.49	CL	600 mm RCP	REMOVE APRON - EXT. PIPE		1	275.622	275.193			15.20	2					4.60	1	24.00			
SUB TOTALS				134.10				104.90	16	31.56	4	15.20	2	23.50	3	29.26	2	157.00	45.00	14.00	
S. A. P. 02-683-01 (C. S. A. H. 83)																					
7+166.00	LT.		NO CULVERT REQUIRED			274.847	274.755														
7+175.00	CL		C/L PIPE CROSSING			275.230	275.066	12.20	2							14.63	2	24.00			
7+193.50	LT.		GRAVEL ENTRANCE			275.608	275.499	10.40	2									15.00			
7+226.00	LT.		BITUMINOUS CROSSING			275.887	275.786	11.60	2									15.00			
7+255.50	RT.		BITUMINOUS ENTRANCE			276.000	275.932	9.80	2												
7+271.00	LT.		GRAVEL ENTRANCE			276.294	276.258	12.80	2												
7+332.20	LT.		BITUMINOUS ENTRANCE			276.378	276.334	15.20	2									15.00			
7+360.60	RT.		BITUMINOUS ENTRANCE			276.464	276.429	12.20	2									15.00			
7+392.60	LT.		BITUMINOUS ENTRANCE			276.431	276.466			15.20	2							18.00			
7+428.00	RT.		175 LANE NW			276.636	276.602	12.20	2									15.00			
7+452.60	LT.		BITUMINOUS ENTRANCE			276.794	276.758	12.20	2									15.00			
7+507.30	RT.		CONCRETE ENTRANCE			277.260	277.311					12.30	2					14.00			
7+628.10	RT.	375 mm CMP	176 AVE. NW			277.260	277.311					12.30	2					14.00			
7+628.10	LT.	375 mm CMP	176 AVE. NW	13.40		277.453	277.369	13.40	2									14.00			
7+658.80	RT.		CONCRETE ENTRANCE			277.453	277.369	14.00	2												
7+725.00	RT.		BITUMINOUS ENTRANCE			278.179	278.177														
7+791.24	LT.	300 mm CMP	NO CULVERT REQUIRED	4.60		276.419	276.305	10.40	2												
7+806.59	RT.	375 mm CMP	NO CULVERT REQUIRED	9.15		278.167	278.176			15.80	2										
7+866.84	LT.	375 mm CMP	BITUMINOUS ENTRANCE	9.15		278.179	278.177			12.30	2										
7+999.44	LT.	375 mm CMP	ERMINE BLVD.	15.20		275.975	276.041	10.40	2												
8+005.81	RT.		178TH AVE N.W.			275.722	275.638	12.20	2												
8+124.50	LT.		GRAVEL ENTRANCE			275.722	275.638	12.20	2												
8+284.00	LT.		178TH AVE N.W.			276.419	276.305	13.40	2												
8+285.40	LT.		GRAVEL ENTRANCE			276.641	276.572	13.40	2												
8+367.00	RT.		GRAVEL ENTRANCE			276.417	276.369														
8+404.10	LT.		NO CULVERT REQUIRED																		
8+408.50	RT.		GRAVEL ENTRANCE																		
8+512.00	C/L	450 mm CMP	C/L PIPE CROSSING	18.29												15.90	2				
SUB TOTALS				69.79				195.80	34	55.50	8	24.60	4	30.53	4			123.00	148.00	6.30	
TOTALS				203.89	1			300.70	50	87.06	12	39.80	6	54.03	7	29.26	2	280.00	193.00	6.30	14.00

(K)

OWNED BY U.S. WEST TELEPHONE COMPANY

STATION TO STATION	LOCATION	DESCRIPTION
S.A.P. 02-683-01 (C.S.A.H. 83)		
8+222.9 - 8+223.3	9.7 m LT 9.8 m RT	BURIED TELEPHONE
8+223.9 - 8+303.0	10.5 m RT 9.5 m RT	BURIED TELEPHONE
8+300.0 - 8+352.1	5.9 m LT 7.3 m LT	BURIED TELEPHONE
8+303.0 - 8+350.9	9.5 m RT 8.5 m RT	BURIED TELEPHONE
8+350.9 - 8+400.0	8.5 m RT 8.1 m RT	BURIED TELEPHONE
8+352.1 - 8+400.0	7.3 m LT 7.9 m LT	BURIED TELEPHONE
8+400.0 - 8+500.0	8.1 m RT 9.6 m RT	BURIED TELEPHONE
8+400.0 - 8+500.0	7.9 m LT 7.4 m LT	BURIED TELEPHONE
8+484.5 - 8+523.5	6.5 m LT 6.4 m LT	BURIED TELEPHONE
8+487.1 - 8+523.4	14.9 m RT 15.0 m RT	BURIED TELEPHONE
8+500.0 - 8+527.5	7.4 m LT 7.2 m LT	BURIED TELEPHONE
8+500.0 - 8+517.4	9.6 m RT 10.4 m RT	BURIED TELEPHONE
8+517.4 - 8+525.4	10.4 m RT 15.8 m RT	BURIED TELEPHONE
8+523.5 - 8+523.5	6.4 m LT 13.4 m LT	BURIED TELEPHONE
8+523.5 - 8+525.0	15.0 m RT 16.2 m RT	BURIED TELEPHONE
8+525.2 - 8+525.0	13.0 m LT 16.1 m RT	BURIED TELEPHONE
8+525.6 - 8+525.4	24.5 m LT 15.8 m RT	B

PUBLIC UTILITY OWNED BY MINNEGASCO (N)				
STATION TO STATION	LOCATION	SIZE	ITEM	
S.A.P. 02-622-27 (C.S.A.H. 22)				
20+000.4 - 20+127.9	7.1 m RT 8.0 m RT	100	POLYETHYLENE GAS	
20+127.9 - 20+205.0	8.0 m RT 8.2 m RT	100	POLYETHYLENE GAS	
20+204.0 - 20+205.0	65.5 m RT 8.2 m RT	100	STEEL GAS	
20+205.0 - 20+321.8	8.2 m RT 7.5 m RT	100	STEEL GAS	
20+321.8 - 20+520.6	7.5 m RT 7.7 m RT	100	STEEL GAS	
20+430.6 - 20+700.6	7.4 m RT 7.0 m RT	100	POLYETHYLENE GAS	
20+700.6 - 20+790.6	7.0 m RT 6.4 m RT	100	POLYETHYLENE GAS	
20+790.6 - 20+815.6	6.4 m RT 6.3 m RT	100	POLYETHYLENE GAS	
20+815.4 - 20+959.4	5.6 m LT 6.6 m LT	100	POLYETHYLENE GAS	
20+815.4 - 20+815.6	5.6 m RT 6.3 m RT	100	POLYETHYLENE GAS	
20+815.6 - 20+820.4	6.3 m RT 16.7 m RT	100	POLYETHYLENE GAS	
20+820.4 - 20+829.6	16.7 m RT 16.5 m RT	100	POLYETHYLENE GAS	
20+959.4 - 20+998.0	6.6 m LT 7.3 m LT	100	POLYETHYLENE GAS	
S.A.P. 02-683-01 (C.S.A.H. 83)				
7+014.8 - 7+078.1	8.2 m LT 8.0 m LT	100	STEEL GAS	
7+078.1 - 7+168.7	8.0 m LT 7.0 m LT	100	STEEL GAS	
7+168.7 - 7+348.0	7.0 m LT 7.1 m LT	100	STEEL GAS	
7+348.0 - 7+546.7	7.1 m LT 7.2 m RT	100	STEEL GAS	
7+546.7 - 7+774.5	7.1 m LT 44.0 m LT	100	STEEL GAS	
7+774.5 - 7+774.5	7.2 m LT 7.4 m LT	100	STEEL GAS	
7+619.3 - 7+620.2	7.2 m LT 34.8 m RT	50	POLYETHYLENE GAS	
7+634.3 - 7+634.6	31.2 m LT 7.3 m LT	50	POLYETHYLENE GAS	
7+754.5 - 7+755.5	7.4 m LT 7.8 m LT	100	STEEL GAS	
7+755.5 - 8+006.9	22.2 m LT 21.4 m RT	150	HYPER POLY GAS	
8+005.1 - 8+013.4	7.8 m LT 19.0 m RT	100	STEEL GAS	
8+006.7 - 8+006.9	24.8 m LT 7.8 m LT	100	STEEL GAS	
8+013.4 - 8+013.7	19.0 m RT 30.0 m RT	100	STEEL GAS	
8+518.0 - 8+518.0	1.1 m LT 16.0 m RT	100	POLYETHYLENE GAS	
8+518.0 - 8+518.9	16.0 m RT 17.2 m RT	100	POLYETHYLENE GAS	
8+518.9 - 8+524.1	17.2 m RT 17.3 m RT	100	POLYETHYLENE GAS	
8+524.1 - 8+525.4	17.3 m RT 18.5 m RT	100	POLYETHYLENE GAS	
8+525.4 - 8+525.4	18.5 m RT 27.2 m RT	100	POLYETHYLENE GAS	

PUBLIC UTILITY OWNED BY CITY (O)			
STATION	LOCATION	DESCRIPTION	NO.
S.A.P. 02-622-27 (C.S.A.H. 22)			
20+204.2	14.60 m RT CL	WATER GATE VALVE	1
S.A.P. 02-683-01 (C.S.A.H. 83)			
7+434.7	6.60 m LT CL	WATER GATE VALVE	1

PUBLIC UTILITY OWNED BY CITY (O)			
STATION	LOCATION	DESCRIPTION	NO.
S.A.P. 02-683-01 (C.S.A.H. 83)			
7+738.5	7.5 m LT CL	VENT LEFT	1
7+913.5	8.0 m LT CL	VENT LEFT	1

OWNED BY NORTHERN STATE POWER (M)				
STATION TO STATION	LOCATION	DESCRIPTION		
S.A.P. 02-683-01 (C.S.A.H. 83)				
7+728.0 - 7+728.0	LSB 18.3 m LT	18.3 m RT	POWER LINE X 83	
8+102.0 - 8+102.0	LSB 18.3 m LT	18.3 m RT	POWER LINE X 83	

OWNED BY U.S. WEST TELEPHONE COMPANY (L)			
STATION	LOCATION OFFSET	ITEM	NO.
S.A.P. 02-683-01 (C.S.A.H. 83)			
8+511.100	26.3 m LT CL	SPLICE BOX ELECTRIC	1

PUBLIC UTILITY

OWNED BY NORTHERN STATE POWER (M)				
STATION	LOCATION	SIZE	NO.	
S.A.P. 02-622-27 (C.S.A.H. 22)				
20+058.2	6.3 m LT CL	POWER POLE	1	
20+066.2	18.4 m RT CL	POWER POLE	1	
20+122.4	6.3 m LT CL	POWER POLE	1	
20+189.9	6.6 m LT CL	POWER POLE	1	
20+257.7	15.5 m RT CL	POWER POLE	1	
20+257.9	6.8 m LT CL	POWER POLE	1	
20+347.9	7.0 m LT CL	POWER POLE	1	
20+430.1	11.8 m RT CL	POWER POLE	1	
20+442.4	7.6 m LT CL	POWER POLE	1	
20+539.3	8.4 m LT CL	POWER POLE	1	
20+624.2	8.6 m LT CL	POWER POLE	1	
20+709.2	8.6 m LT CL	POWER POLE	1	
20+798.8	9.0 m LT CL	POWER POLE	1	
20+815.7	62.6 m RT CL	POWER POLE	1	
S.A.P. 02-683-01 (C.S.A.H. 83)				
7+011.3	9.8 m LT CL	POWER POLE	1	
7+113.7	10.7 m LT CL	POWER POLE	1	
7+171.0	9.1 m LT CL	POWER POLE	1	
7+176.0	11.2 m RT CL	POWER POLE	1	
7+234.8	11.3 m RT CL	POWER POLE	1	
7+297.7	11.3 m RT CL	POWER POLE	1	
7+298.3	9.4 m LT CL	POWER POLE	1	
7+333.8	11.3 m RT CL	POWER POLE	1	
7+419.1	21.6 m RT CL	POWER POLE	1	
7+420.2	10.6 m LT CL	POWER POLE	1	
7+444.4	11.6 m RT CL	POWER POLE	1	
7+537.1	11.6 m RT CL	POWER POLE	1	
7+606.4	10.7 m RT CL	POWER POLE	1	
7+637.3	9.7 m LT CL	POWER POLE	1	
7+637.7	10.7 m RT CL	POWER POLE	1	
7+731.1	15.8 m RT CL	POWER POLE	1	
7+764.5	10.4 m RT CL	POWER POLE	1	
7+835.9	11.6 m LT CL	POWER POLE	1	
7+853.6	10.1 m RT CL	POWER POLE	1	
7+949.5	24.8 m RT CL	POWER POLE	1	
7+949.6	10.2 m RT CL	POWER POLE	1	
8+009.0	11.9 m LT CL	POWER POLE	1	
8+014.9	11.0 m RT CL	POWER POLE	1	
8+073.2	11.3 m RT CL	POWER POLE	1	
8+099.8	33.8 m RT CL	POWER POLE	1	
8+106.2	33.8 m RT CL	POWER POLE	1	
8+221.2	12.2 m RT CL	POWER POLE	1	
8+313.1	11.9 m RT CL	POWER POLE	1	
8+401.2	9.4 m LT CL	POWER POLE	1	
8+403.0	10.9 m RT CL	POWER POLE	1	
8+470.8	11.1 m RT CL	POWER POLE	1	
8+472.1	15.0 m LT CL	POWER POLE	1	

PUBLIC UTILITY OWNED BY MINNEGASCO (N)				
STATION TO STATION	LOCATION	DESCRIPTION		
S.A.P. 02-683-01 (C.S.A.H. 83)				
7+051.80 - 7+052.10	CL 8.7 m LT	11.4 m RT	BURIED TELEVISION	
7+052.10 - 7+123.00	CL 11.4 m RT	11.0 m RT	BURIED TELEVISION	
7+123.00 - 7+245.60	CL 11.0 m RT	10.6 m RT	BURIED TELEVISION	
7+245.60 - 7+416.00	CL 10.6 m RT	11.0 m RT	BURIED TELEVISION	
7+416.00 - 7+637.70	CL 11.0 m RT	10.4 m RT	BURIED TELEVISION	
7+637.70 - 7+801.20	CL 45.2 m LT	10.4 m RT	BURIED TELEVISION	
7+801.20 - 8+015.20	CL 10.4 m RT	9.8 m RT	BURIED TELEVISION	
8+014.90 - 8+015.20	CL 9.8 m RT	10.3 m RT	BURIED TELEVISION	
8+014.90 - 8+121.90	CL 16.1 m LT	10.3 m RT	BURIED TELEVISION	
8+014.90 - 8+121.90	CL 16.1 m LT	16.2 m LT	BURIED TELEVISION	
8+009.00	CL 9.0 m LT		SPLICE BOX TELEVISION	

OWNED BY U.S. WEST TELEPHONE COMPANY (L)				
STATION	LOCATION	NO.		
S.A.P. 02-622-27 (C.S.A.H. 22)				
20+793.6	7.6 m RT	LEB	TELEPHONE MANHOLE 1	
S.A.P. 02-683-01 (C.S.A.H. 83)				
8+527.2	37 m LT	LSB	TELEPHONE MANHOLE 1	

PUBLIC UTILITY

OWNED BY U.S. WEST TELEPHONE COMPANY (L)				
STATION TO STATION	LOCATION	DESCRIPTION		
S.A.P. 02-622-27 (C.S.A.H. 22)				
20+020.0 - 20+057.5	CL 7.0 m RT	8.2 m RT	BURIED TELEPHONE	
20+045.1 - 20+044.9	CL 7.8 m RT	17.7 m RT	BURIED TELEPHONE	
20+057.5 - 20+082.0	CL 8.2 m RT	9.0 m RT	BURIED TELEPHONE	
20+081.9 - 20+082.0	CL 12.2 m RT	9.0 m RT	BURIED TELEPHONE	
20+082.0 - 20+170.0	CL 9.0 m RT	9.4 m RT	BURIED TELEPHONE	
20+180.0 - 20+203.7	CL 9.4 m RT	9.4 m RT	BURIED TELEPHONE	
20+190.6 - 20+190.3	CL 9.5 m RT	46.5 m RT	BURIED TELEPHONE	
20+203.7 - 20+285.0	CL 9.4 m RT	8.2 m RT	BURIED TELEPHONE	
20+210.0 - 20+292.8	CL 13.8 m RT	13.7 m RT	BURIED TELEPHONE	
20+285.0 - 20+369.9	CL 8.2 m RT	8.0 m RT	BURIED TELEPHONE	
20+292.8 - 20+375.3	CL 13.7 m RT	13.6 m RT	BURIED TELEPHONE	
20+369.9 - 20+507.4	CL 8.0 m RT	8.5 m RT	BURIED TELEPHONE	
20+375.3 - 20+429.9	CL 13.6 m RT	13.5 m RT	BURIED TELEPHONE	
20+490.3 - 20+490.4	CL 8.4 m RT	8.1 m LT	BURIED TELEPHONE	
20+507.4 - 20+600.0	CL 8.5 m RT	9.0 m RT	BURIED TELEPHONE	
20+600.0 - 20+707.4	CL 9.0 m RT	8.4 m RT	BURIED TELEPHONE	
20+707.4 - 20+781.3	CL 8.4 m RT	7.7 m RT	BURIED TELEPHONE	
20+781.3 - 20+792.8	CL 7.7 m RT	7.6 m RT	BURIED TELEPHONE	
20+794.1 - 20+794.2	CL 7.0 m RT	6.9 m LT	BURIED TELEPHONE	
20+794.2 - 20+818.7	CL 6.9 m LT	6.9 m LT	BURIED TELEPHONE	
20+795.4 - 20+802.9	CL 7.8 m RT	7.8 m RT	BURIED TELEPHONE	
20+795.4 - 20+803.7	CL 7.5 m RT	7.5 m RT	BURIED TELEPHONE	
20+802.9 - 20+802.9	CL 7.8 m RT	19.9 m RT	BURIED TELEPHONE	
20+803.7 - 20+803.8	CL 7.5 m RT	12.2 m RT	BURIED TELEPHONE	
20+803.7 - 20+805.1	CL 9.6 m RT	9.6 m RT	BURIED TELEPHONE	
20+803.8 - 20+804.7	CL 11.2 m RT	11.2 m RT	BURIED TELEPHONE	
20+806.5 - 20+806.2	CL 6.9 m LT	9.2 m RT	BURIED TELEPHONE	
20+806.2 - 20+830.4	CL 9.2 m RT	9.2 m RT	BURIED TELEPHONE	
20+817.9 - 20+848.9	CL 6.9 m LT	6.0 m LT	BURIED TELEPHONE	
20+818.7 - 20+842.7	CL 6.9 m LT	7.1 m LT	BURIED TELEPHONE	
20+842.7 - 20+878.3	CL 7.1 m LT	6.8 m LT	BURIED TELEPHONE	
20+845.6 - 20+845.6	CL 12.8 m LT	8.3 m LT	BURIED TELEPHONE	
20+845.6 - 20+882.1	CL 8.3 m LT	7.9 m LT	BURIED TELEPHONE	
20+848.9 - 20+876.2	CL 7.5 m LT	7.5 m LT	BURIED TELEPHONE	
20+878.3 - 20+935.8	CL 6.8 m LT	6.2 m LT	BURIED TELEPHONE	
20+882.1 - 20+935.8	CL 7.9 m LT	7.7 m LT	BURIED TELEPHONE	
S.A.P. 02-683-01 (C.S.A.H. 83)				
7+020.0 - 7+082.1	CL 4.3 m LT	4.7 m LT	BURIED TELEPHONE	
7+020.0 - 7+083.6	CL 10.1 m RT	8.2 m RT	BURIED TELEPHONE	
7+020.0 - 7+040.8	CL 12.0 m RT	11.8 m RT	BURIED TELEPHONE	
7+082.1 - 7+127.0	CL 4.7 m LT	5.0 m LT	BURIED TELEPHONE	
7+083.6 - 7+121.1	CL 10.1 m RT	7.4 m RT	BURIED TELEPHONE	
7+121.0 - 7+200.0	CL 7.4 m RT	6.6 m RT	BURIED TELEPHONE	
7+127.0 - 7+217.0	CL 4.7 m LT	5.4 m LT	BURIED TELEPHONE	
7+200.0 - 7+300.0	CL 6.6 m RT	7.1 m RT	BURIED TELEPHONE	
7+217.0 - 7+400.0	CL 5.4 m LT	5.4 m LT	BURIED TELEPHONE	
7+300.0 - 7+398.6	CL 7.1 m RT	8.5 m RT	BURIED TELEPHONE	
7+400.0 - 7+610.5	CL 5.4 m LT	5.5 m LT	BURIED TELEPHONE	
7+421.6 - 7+517.7	CL 13.7 m RT	13.1 m RT	BURIED TELEPHONE	
7+421.6 - 7+421.8	CL 13.7 m RT	57.4 m RT	BURIED TELEPHONE	
7+398.6 - 7+608.1	CL 8.5 m RT	8.6 m RT	BURIED TELEPHONE	
7+517.7 - 7+607.7	CL 13.1 m RT	13.5 m RT	BURIED TELEPHONE	
7+607.7 - 7+635.6	CL 13.5 m RT	13.5 m RT	BURIED TELEPHONE	
7+606.1 - 7+708.1	CL 8.6 m RT	8.6 m RT	BURIED TELEPHONE	
7+610.5 - 7+707.0	CL 5.5 m LT	6.5 m LT	BURIED TELEPHONE	
7+622.8 - 7+621.8	CL 71.0 m RT	13.5 m RT	BURIED TELEPHONE	
7+635.6 - 7+637.0	CL 13.5 m RT	72.2 m RT	BURIED TELEPHONE	
7+635.6 - 7+640.1	CL 13.5 m RT	10.3 m RT	BURIED TELEPHONE	
7+706.1 - 7+811.4	CL 8.6 m RT	9.0 m RT	BURIED TELEPHONE	
7+707.0 - 7+810.5	CL 6.5 m LT	6.9 m LT	BURIED TELEPHONE	
7+810.5 - 7+900.0	CL 6.9 m LT	6.4 m LT	BURIED TELEPHONE	
7+811.4 - 7+900.0	CL 9.0 m RT	8.6 m RT	BURIED TELEPHONE	
7+900.0 - 7+952.0	CL 6.4 m LT	5.6 m LT	BURIED TELEPHONE	
7+900.0 - 7+951.1	CL 8.6 m RT	8.6 m RT	BURIED TELEPHONE	
7+951.1 - 8+000.0	CL 8.6 m RT	8.6 m RT	BURIED TELEPHONE	
7+952.0 - 8+000.0	CL 5.6 m LT	4.9 m LT	BURIED TELEPHONE	
8+000.0 - 8+048.0	CL 4.9 m LT	5.6 m LT	BURIED TELEPHONE	
8+000.0 - 8+048.9	CL 8.6 m RT	8.8 m RT	BURIED TELEPHONE	
8+048.0 - 8+107.0	CL 5.6 m LT	6.3 m LT	BURIED TELEPHONE	
8+048.9 - 8+106.1	CL 8.8 m RT	9.2 m RT	BURIED TELEPHONE	
8+106.1 - 8+151.2	CL 9.2 m RT	9.8 m RT	BURIED TELEPHONE	
8+107.0 - 8+152.0	CL 6.3 m LT	5.6 m LT	BURIED TELEPHONE	
8+151.2 - 8+200.0	CL 9.8 m RT	10.6 m RT		

EARTHWORK SUMMARY (P)

BALANCE

Fed. Project No. _____

EXCAVATION

COMMON EXCAVATION
TOTAL = 33 950 m³

COMMON EXC. . .13 702 m ³	REGULAR 9 301 m ³ ①	SAP 02-622-27
	TOPSOIL 2 258 m ³	
	SUBCUT 2 143 m ³	
COMMON EXC. . .20 248 m ³	REGULAR 12 130 m ³ ②	SAP 02-683-01
	TOPSOIL 3 219 m ³	
	SUBCUT 4 899 m ³	
MUCK EXC. 330 m ³ (PAY ITEM)		
SPECIAL EXC . . .1 782 m ³ (PAY ITEM)		

COMMON EXCAVATION - REMOVALS = 33 950 - 4 330 = 29 620 m³ (PAY ITEM)

EMBANKMENT (CV)

SAP 02-622-27

SAP 02-683-01

REGULAR 2 300 m ³
SUBCUT 2 238 m ³
TOPSOIL SALVAGE 1 802 m ³
BACK FILL FOR MUCK 330 m ³

REGULAR 1 497 m ³
SUBCUT 4 899 m ³
TOPSOIL 2 507 m ³
BACK FILL FOR MUCK 3 330 m ³
MUCK 730 m ³
GRANULAR BORROW 1 782 m ³
FOR SPECIAL EXC. FILL

- SOIL FACTORS:**
- REGULAR GRADING AND TOPSOIL DRESSING (EV TO CV): 80% SHRINKAGE
 - SUBCUT COMPACTION (EV TO CV): 90% SHRINKAGE
 - SELECT GRANULAR BORROW (CV TO LV): 120% SWELL
 - TOPSOIL BORROW (CV TO LV): 130% SWELL
 - MUCK EXCAVATION (EV TO CV): 70% SHRINKAGE

TOPSOIL S.A.P. 02-622-27

[TOPSOIL STRIPPING (EV) x SHRINKAGE FACTOR] - [TOPSOIL DRESSING-TOPSOIL BORROW] (CV)
 FACTOR] = EXCESS (+) OR SHORTAGE (-)
 (2258 x 0.80) - 1802 = 5 m³ EXCESS (CV), (SEE NOTE 17, 21)
 5 x 1.30 = 6.5 m³ EXCESS (LV), (SEE NOTE 22)

EMBANKMENT MATERIAL

[(REG. EXCAVATION (EV)-REMOVALS) x SHRINKAGE FACT.] + [SUBCUT x SHRINKAGE FACT.] + [SPECIAL x SHRINKAGE FACT.]
 - [REG. EMBANKMENT (CV) + SUBCUT + SPECIAL OR MUCK BACK FILL] = SHORTAGE (-) OR EXCESS (+).
 [(9 301 - 1 680) x 0.80 + (2 143 x 0.90)] - [(2 300 + 2 143 + 330)] = +3 252.50 m³ EXCESS (CV)
 (REG. EXC. (CV) x SWELL FACTOR) + (SUBCUT EXC. (CV) x SWELL FACTOR) = EXCESS (LV)
 (3 252.50 x 1.20) = 3 903.00 m³ (LV) EXCESS

MUCK

[(MUCK EXC. (EV) x SHRINKAGE) - [MUCK EMBANKMENT (CV)] = EXCESS(+) OR SHORTAGE(-)
 (330 x 0.70) = +231 m³ (CV) EXCESS

TOPSOIL S.A.P. 02-683-01

(3 219 x 0.80) - 2 507 = 69 m³ EXCESS (CV), (SEE NOTE 17, 21.)
 69 x 1.3 = 89.70 m³ EXCESS (LV), (SEE NOTE 22)

EMBANKMENT MATERIAL

[(12 130 - 2 650) x 0.80 + (4 899 x 0.90) + (1 782 x 0.8)] - (1 497 + 4 899 + 3 330) = +3 692.70 m³ EXCESS (CV)
 (1 910.7 x 1.20) = 2 292.84 m³ (LV) EXCESS

GRANULAR BORROW

(GRANULAR BORROW (CV) x SHRINKAGE FACT.) = (LV), (1 782 x 1.20) = 2 138 m³ (LV) BORROW

MUCK

(4 074 x 0.70) - 730 = +2 122 m³ (CV) EXCESS (SEE NOTE 22)

① INCLUDES 1 680 m³ OF BITUMINOUS AND CONC. PAVEMENT REMOVALS. (SEE REMOVAL CHARTS FOR PAY ITEMS.)
 ② INCLUDES 2 650 m³ OF BITUMINOUS AND CONC. PAVEMENT REMOVALS.

SOILS AND CONSTRUCTION NOTES:

- TOP OF GRADING GRADE IS DEFINED AS THE BOTTOM OF THE AGGREGATE BASE.
- IN FILL AREAS, THE SUBGRADE SHALL BE CONSTRUCTED WITH SELECTED GRADING MATERIAL.
- SELECTED GRADING MATERIALS SHALL CONSIST OF SELECT GRANULAR MATERIALS.
- GRANULAR MATERIAL, REGARDLESS OF SOURCE, SHALL MEET THE REQUIREMENTS OF SPEC. 3149.2B.
- COMPACTION OF THE GRADING PORTION OF THIS PROJECT SHALL BE BY THE "SPECIFIED DENSITY METHOD".
- TEST ROLLING WILL NOT BE REQUIRED.
- BITUMINOUS OR CONCRETE ITEMS REMOVED BY CONSTRUCTION SHALL BECOME THE PROPERTY OF THE CONTRACTOR AND SHALL BE EITHER RECYCLED OR DISPOSED OF IN ACCORDANCE WITH THE REQUIREMENTS OF 2104.3C3 WITH NO DIRECT COMPENSATION MADE THEREFORE.
- DISPOSITION OF EXCESS EXCAVATED MATERIAL SHALL BE IN ACCORDANCE WITH THE REQUIREMENTS OF 2105.3D WITH NO DIRECT COMPENSATION THEREFORE.
- WHERE MATCHING INTO THE INPLACE ROADWAY AT THE ENDS OF CONSTRUCTION, CUT VERTICALLY TO THE TOP OF THE GRADING GRADE, AND THEN AT A 20:1 TAPER TO THE BOTTOM OF THE RECOMMENDED SUBGRADE EXCAVATION.
- WHERE CONNECTING NEW SURFACING TO AN INPLACE PAVEMENT, THE EXCAVATION SHALL BE BACKFILLED PROMPTLY TO AVOID UNDERMINING THE INPLACE PAVEMENT.
- USE TACK COAT BETWEEN ALL BITUMINOUS MIXTURES PRIOR TO PLACING BITUMINOUS MIXTURES AND PRIOR TO PLACING ANY BITUMINOUS MIXTURES ON EXISTING CONCRETE OR BITUMINOUS SURFACES. THE BITUMINOUS TACK COAT MATERIAL SHALL BE APPLIED AT UNIFORM RATE OF 0.23 L/m² BETWEEN BITUMINOUS LAYERS. THE APPLICATION RATES ARE FOR UNDILUTED EMULSION (AS SUPPLIED FROM THE REFINERY); ASPHALT EMULSION MAY BE FURTHER DILUTED IN THE FIELD IN ACCORDANCE WITH SPEC. 2357.
- COMPACTION OF THE AGGREGATE BASE LAYERS SHALL BE BY THE "SPECIFIED DENSITY METHOD", UNLESS RECYCLED MATERIAL'S.
- PLACE MINIMUM 100 mm TOPSOIL OR SLOPE DRESSING ON ALL AREAS DISTURBED BY CONSTRUCTION AND SCHEDULED FOR PERMANENT TURF ESTABLISHMENT. FERTILIZE WITH COMMERCIAL FERTILIZER, ANALYSIS 10-10-10, AT A RATE OF 560 kg PER ha.
- USE MIXTURE 70A SEED AND TYPE 1 MULCH IN AREAS TO BE SEEDED.
- SOD ALL MAINTAINED LAWNS DISTURBED BY CONSTRUCTION.
- ALL SOD UTILIZED WITHIN THE PROJECT LIMITS SHALL MEET THE REQUIREMENTS OF SPEC. 3878.2C (LAWN SOD).
- ORGANIC AND NONGRANULAR EXCAVATED MATERIAL MAY BE USED IN EMBANKMENT CONSTRUCTION IN AREAS OUTSIDE OF A 1 1/2:1 SLOPE FROM THE BACK OF CURB, OR GRADING P.I.
- BITUMINOUS REMOVAL QUANTITY BASED ON SQUARE METER REMOVED. IN PLACE SURFACE ASSUMED TO BE 210 mm IN DEPTH. CONTRACTOR SHALL INVESTIGATE AND MAKE OWN DETERMINATION OF ACTUAL PAVEMENT DEPTH.
- ALL SILT FENCING AS SHOWN IN THE PLANS SHALL BE IN PLACE PRIOR TO THE COMMENCEMENT OF GRADING OPERATIONS.
- A DOUBLE ROW OF BALE CHECKS SHALL BE INSTALLED ALONG DITCH RUNS FOR EROSION CONTROL AS DIRECTED BY THE ENGINEER.
- TOPSOIL STRIPPINGS TO BE SALVAGED AND UTILIZED TO ITS FULLEST EXTENT WITHIN THE PROJECT LIMITS.
- ORGANIC MATERIAL CAN BE USED AS SALVAGED TOPSOIL AND AS EMBANKMENT OUTSIDE THE ROAD BED CONSTRUCTION.

BASE AND BITUMINOUS QUANTITIES CHART (Q)

STATION - STATION	LOCATION	DESCRIPTION	BIT. SURFACE CONSTRUCTION AREA m ²	BITUMINOUS			AGGREGATE		SUBCUT 300 mm m ³
				WEARING C. 40 mm t	BASE COURSE 80 mm t	TACK COAT LITERS	BASE AREA m ²	BASE CL-5 150 mm m ³	
S.A.P. 02-622-27 C.S.A.H. 22									
20+000.00	20+808.20	3.60 LT & RT CL	5819.040	546.990	1225.029	2676.758	5819.040	872.856	1745.712
20+851.70	20+993.60	3.60 LT & RT CL	1021.680	96.038	215.085	469.973	1021.680	153.252	308.504
20+000.00	20+050.25	3.60 - 6.00 RT CL	120.600	11.336			170.197	29.145	44.823
20+000.00	20+125.27	3.60 - 6.00 LT CL	300.648	28.261			424.289	197.927	111.741
20+050.25	20+211.57	3.60 - 7.20 RT CL	580.752	54.591	122.260	267.146	783.370	110.666	201.973
20+125.27	20+308.27	3.60 - 7.20 LT CL	658.800	61.927	138.691	303.048	888.648	125.538	229.116
20+211.57	20+678.91	3.60 - 6.00 RT CL	1121.616	105.432			1582.881	271.057	416.867
20+308.27	20+808.20	3.60 - 6.00 LT CL	1199.832	112.784			1693.263	289.959	445.938
20+678.91	20+808.20	3.60 - 7.20 RT CL	465.444	43.752	97.986	214.104	627.832	88.693	161.871
20+851.70	20+980.60	3.60 - 7.20 LT CL	464.040	43.620	97.690	213.458	625.938	88.425	161.383
20+851.70	20+926.65	3.60 - 6.00 RT CL	179.880	16.909			253.856	43.471	45.212
20+980.60	20+993.60	3.60 - 4.10 LT CL					14.806	1.950	4.576
20+926.65	20+993.60	3.60 - 4.10 RT CL					80.072	9.373	27.597
20+198.21		RT CL	116.070	10.911	24.410	55.559	161.412	22.278	39.531
20+808.20	20+851.70	LT & RT CL	771.229	72.496	157.230	354.765	771.229	115.684	231.369
SUBTOTAL			12819.631	1205.045	2078.381	4554.812	14918.512	2420.274	4174.212
S.A.P. 02-683-01 C.S.A.H. 83									
7+043.927	7+829.140	3.6 LT & RT CL	10693.519	1005.191	2251.209	4919.019	10693.519	1604.028	3208056
7+043.930	7+097.000	3.6 - 7.2 LT CL	191.063	17.960	40.223	91.551	257.722	36.408	66.447
7+043.930	7+279.960	3.6 - 6.0 RT CL	566.479	53.249			799.444	136.899	210.541
7+097.000	7+354.340	3.6 - 6.0 LT CL	617.614	58.056			871.607	149.257	229.546
7+279.960	7+443.540	3.6 - 7.2 RT CL	588.884	55.355	123.972	282.174	794.340	112.215	204.801
7+354.340	7+537.340	3.6 - 7.2 LT CL	658.800	61.927	138.691	315.675	888.648	125.538	229.116
7+443.540	7+481.120	3.6 - 6.0 RT CL	90.204	8.479			127.300	21.799	33.526
7+537.340	7+611.570	3.6 - 6.0 LT CL	178.157	16.747			251.424	43.055	66.215
7+481.120	7+645.440	3.6 - 7.2 RT CL	591.538	55.605	124.531	283.445	797.918	112.721	205.724
7+611.570	7+776.020	3.6 - 7.2 LT CL	591.995	55.648	124.627	283.664	798.535	112.808	205.883
7+645.440	7+858.140	3.6 - 6.0 RT CL	510.473	47.984			720.405	123.364	189.726
7+776.020	7+982.583	3.6 - 6.0 LT CL	495.766	46.602			699.649	119.810	184.260
7+858.140	8+022.458	3.6 - 7.2 RT CL	591.556	55.606	124.535	283.454	797.943	112.724	205.730
7+982.583	8+146.880	3.6 - 7.2 LT CL	591.476	55.599	124.518	283.416	797.836	112.709	205.702
8+022.458	8+386.709	3.6 - 6.0 RT CL	874.202	82.175			1233.718	211.266	324.912
8+146.880	8+516.100	3.6 - 6.0 LT CL	886.123	83.296			1250.541	214.146	329.342
8+386.709	8+530.750	3.6 - 7.2 RT CL	518.548	48.743	109.165	238.532	699.463	98.812	180.339
7+427.500		RT CL	113.070	10.629	23.803	54.179	158.412	21.828	38.631
7+630.000		LT CL	114.940	10.804	24.181	55.039	160.282	22.108	39.192
7+630.000		RT CL	116.070	10.911	24.410	55.559	161.412	22.278	39.531
8+000.500		LT CL	116.097	10.913	24.415	55.571	161.439	22.282	39.539
8+006.500		RT CL	116.079	10.911	24.411	55.563	161.421	22.279	39.534
SUBTOTAL			19812.652	1862.389	3282.692	7256.840	23282.977	3558.33	6476.293
TOTAL			32632.283	3067.435	5361.072	11811.652	38201.490	5978.607	10640.745

NOTES:
TACK COAT INCLUDES TWO LAYERS BASE COURSE (0.23 L/m²)
6 mm BITUMINOUS THICKNESS ADDED BASE COURSE.

TABULATION CHARTS

EARTHWORK SUMMARY, CONSTRUCTION NOTES
BASE AND BITUMINOUS QUANTITIES CHART

NO	DATE	BY	CKD	APPR	REVISION
1	10-27-99	M.N.			
NAME: 08-EARTH.dwg 4-21-00 1:19:06 pm EST					



I HEREBY CERTIFY THAT THIS PLAN WAS PREPARED BY ME OR UNDER MY DIRECT SUPERVISION AND THAT I AM A DULY REGISTERED PROFESSIONAL ENGINEER UNDER THE LAWS OF THE STATE OF MINNESOTA.

Allyson

DATE 04-20-00 REG. NO. 25066

DRAWN BY: MN DATE 12/22/99
 DESIGN BY: MN DATE 12/22/99
 CHECKED BY: LR DATE 12/22/99



**ANOKA COUNTY
HIGHWAY DEPT.**

STATE PROJECT NO. _____
 STATE AID PROJECT NO. 02-622-27
 STATE AID PROJECT NO. 02-683-01
 COUNTY PROJECT NO. _____

TABULATION CHARTS
 Sheet 8 of 56 Sheets

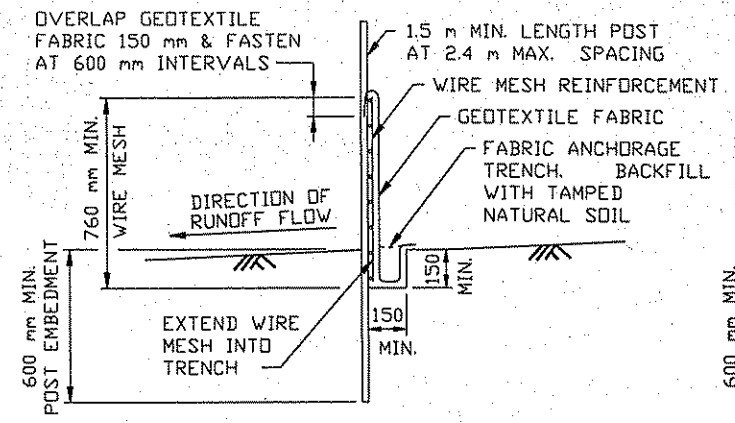

HEAVY DUTY

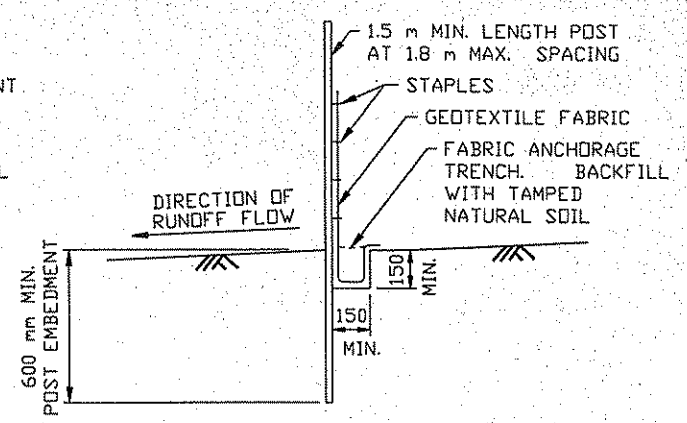

SELF SUPPORTING

SILT FENCE DETAILS
TO PROTECT AREAS FROM SHEET FLOW
(SEE SPEC. 3886)

DESIGN CRITERIA:
MAXIMUM CONTRIBUTING AREA: 1.2 ha

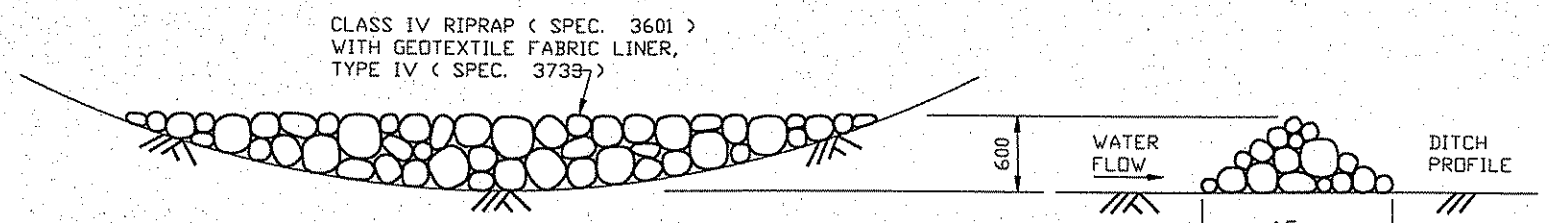

CROSS SECTION

PROFILE VIEW

ROCK DITCH CHECK

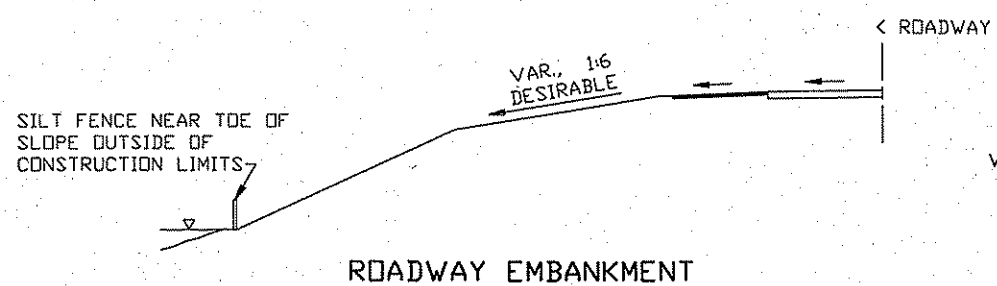

ROADWAY EMBANKMENT

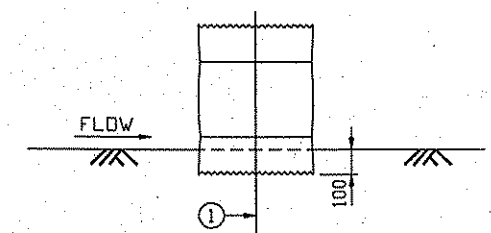

BALE CHECK DETAIL

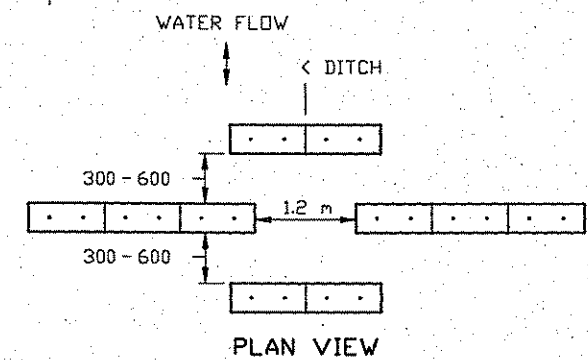

PLAN VIEW

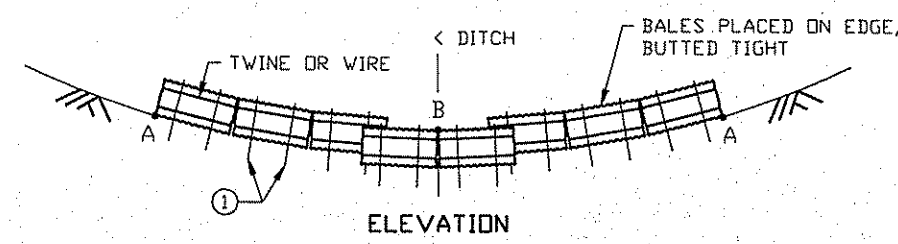

ELEVATION

NOTE:
POINT A MUST BE HIGHER THAN POINT B

BALE DITCH VELOCITY CHECKS
(WILL REQUIRE A MINIMUM OF 10 BALES PER SITE)

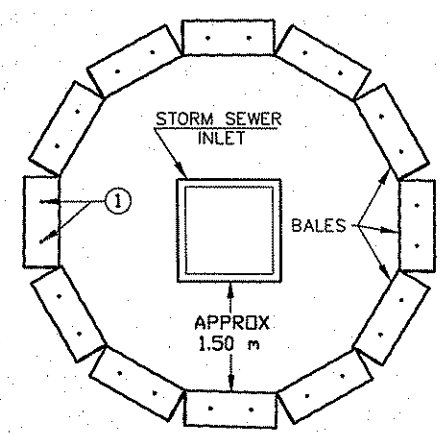

BALE CHECK
TO PROTECT STORM SEWER INLETS

RECOMMENDED SPACING BETWEEN DITCH CHECKS	
DITCH GRADE (%)	SPACING (m)
2	30
4	23
6	15
8	12
10	8

DESIGN CRITERIA:

	BALE	ROCK
STORM FREQUENCY:	2 YR. - 24 HR.	10 YR. - 24 HR.
MAX. FLOW VELOCITY:	1.5 m/s	3.6 m/s
MAX. DITCH GRADE:	5%	—
MAX. DRAINAGE AREA:	0.8 ha	2.0 ha

NOTE:
TWO 50 mm X 50 mm WOOD STAKES OR REINFORCING BARS IN EACH BALE AND EMBEDDED IN THE GROUND 250 mm MINIMUM.

NOTE: ALL DIMENSIONS ARE IN MILLIMETERS, EXCEPT AS NOTED.

NO	DATE	BY	CKD	APPR	REVISION

NAME: 09-Erosion.dwg 4-21-00 7:49:36 am EST

I HEREBY CERTIFY THAT THIS PLAN WAS PREPARED BY ME OR UNDER MY DIRECT SUPERVISION AND THAT I AM A DULY REGISTERED PROFESSIONAL ENGINEER UNDER THE LAWS OF THE STATE OF MINNESOTA.

Albert

DATE 04-20-00 REG. NO. 25066

DRAWN BY _____ DATE _____
DESIGN BY _____ DATE _____
CHECKED BY _____ DATE _____

ANOKA COUNTY
HIGHWAY DEPT.

STATE PROJECT NO. _____
STATE AID PROJECT NO. 02-622-27
STATE AID PROJECT NO. 02-683-01
COUNTY PROJECT NO. _____

TEMPORARY EROSION CONTROL

Sheet 9 of 56 Sheets

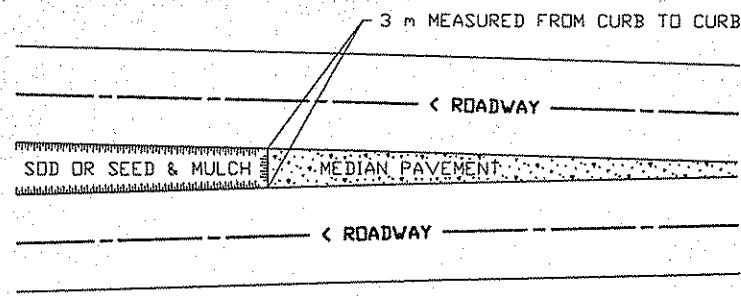

SODDING LIMITS AT GORE AREA

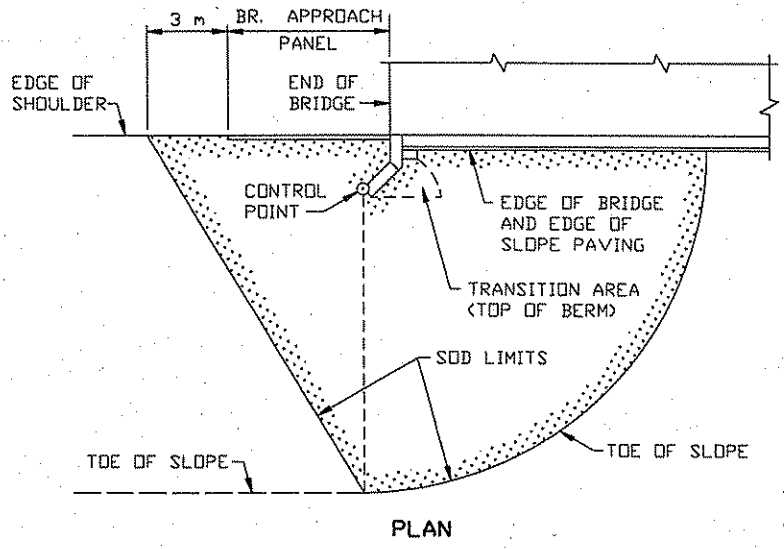

PLAN

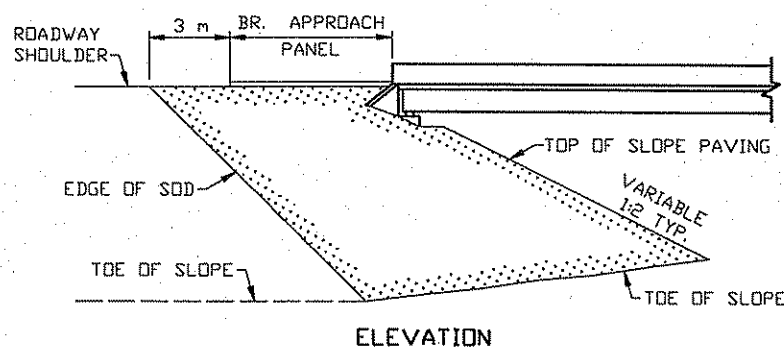

ELEVATION

SODDING LIMITS AT BRIDGE APPROACH FILLS

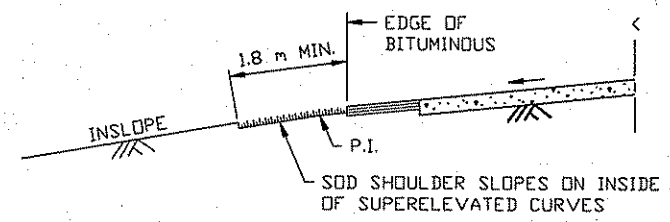

SODDING INSLOPES OF SUPERELEVATED CURVES

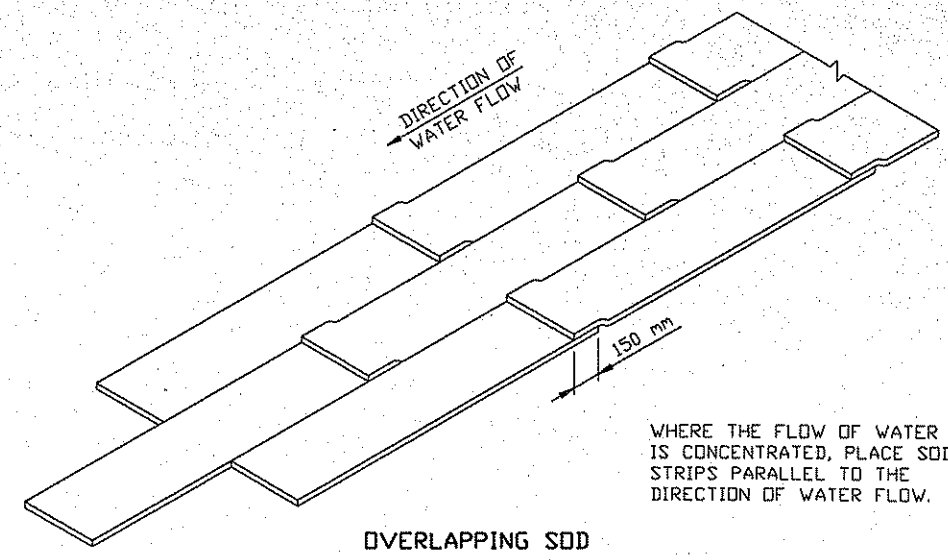

OVERLAPPING SOD

WHERE THE FLOW OF WATER IS CONCENTRATED, PLACE SOD STRIPS PARALLEL TO THE DIRECTION OF WATER FLOW.

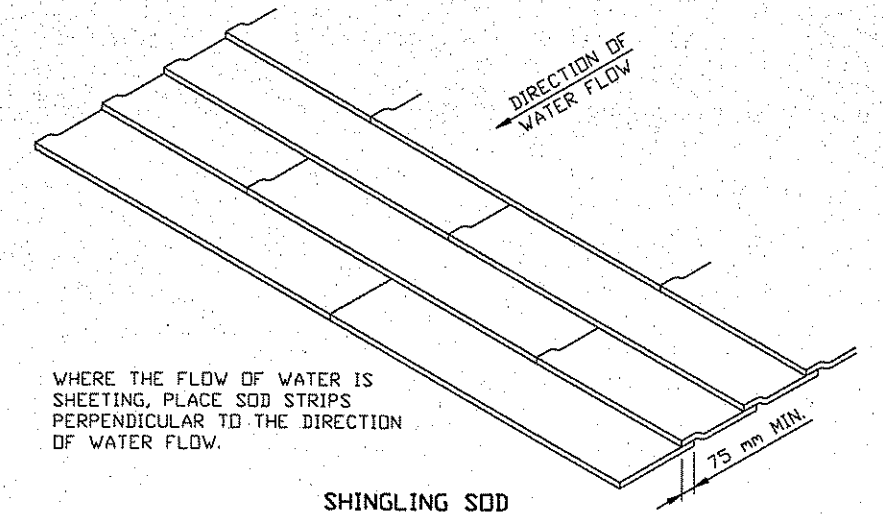

SHINGLING SOD

WHERE THE FLOW OF WATER IS SHEETING, PLACE SOD STRIPS PERPENDICULAR TO THE DIRECTION OF WATER FLOW.

SPECIAL SOD PLACEMENT TECHNIQUES

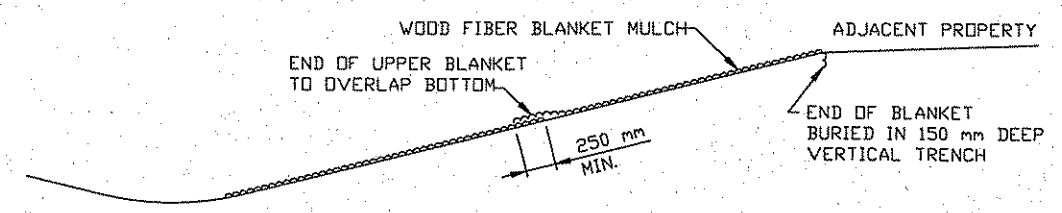

WOOD FIBER BLANKET INSTALLATION ON A CUT SLOPE

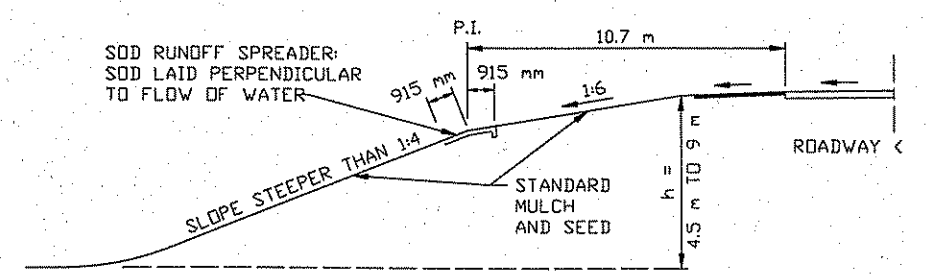

BROKEN-BACK SAFETY FILL SLOPE

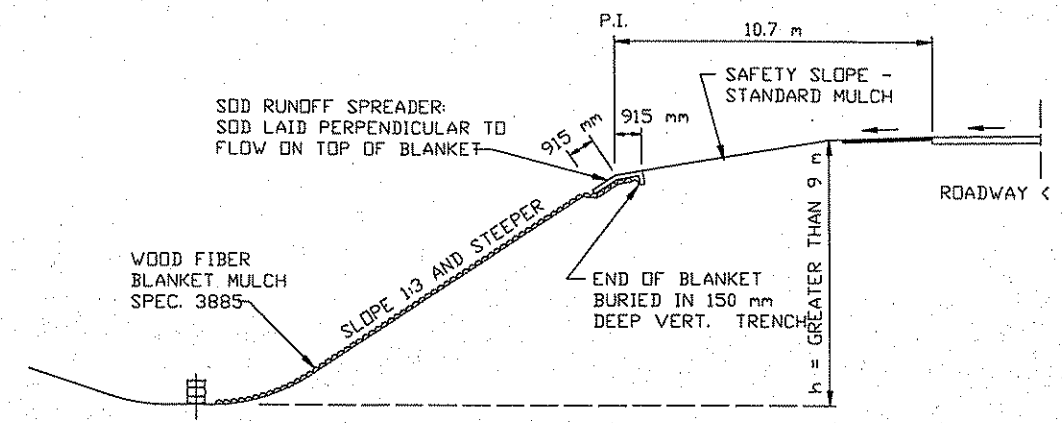

WOOD FIBER BLANKET INSTALLATION ON AN INSLOPE (WHEN REQUIRED)

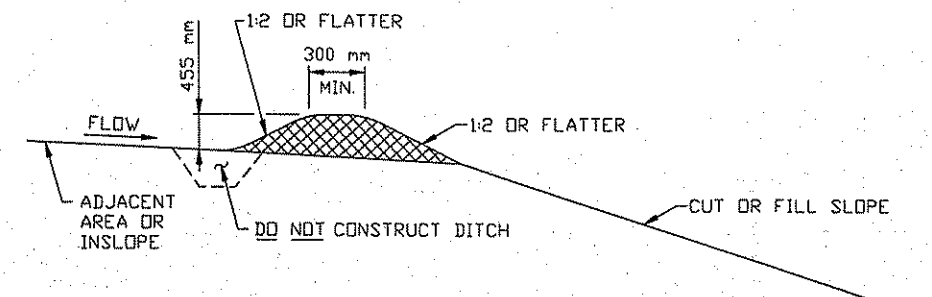

PERMANENT SLOPE PROTECTION DIKE

NO	DATE	BY	CKD	APPR	REVISION
1	10-21-00	dwo			

NAME: 10-Frosiondwo 4-21-00 7:50:22 am EST

I HEREBY CERTIFY THAT THIS PLAN WAS PREPARED BY ME OR UNDER MY DIRECT SUPERVISION AND THAT I AM A DULY REGISTERED PROFESSIONAL ENGINEER UNDER THE LAWS OF THE STATE OF MINNESOTA.

Albert B.

DATE 04-20-00 REG. NO. 25066

DRAWN BY: MN DATE 00/00/98
 DESIGN BY: DWE DATE 00/00/98
 CHECKED BY: DWE DATE 00/00/98

ANOKA COUNTY
HIGHWAY DEPT.

STATE PROJECT NO. _____
 STATE AID PROJECT NO. 02-622-27
 STATE AID PROJECT NO. 02-683-01
 COUNTY PROJECT NO. _____

EROSION CONTROL
DETAILS

Sheet 10 of 56 Sheets

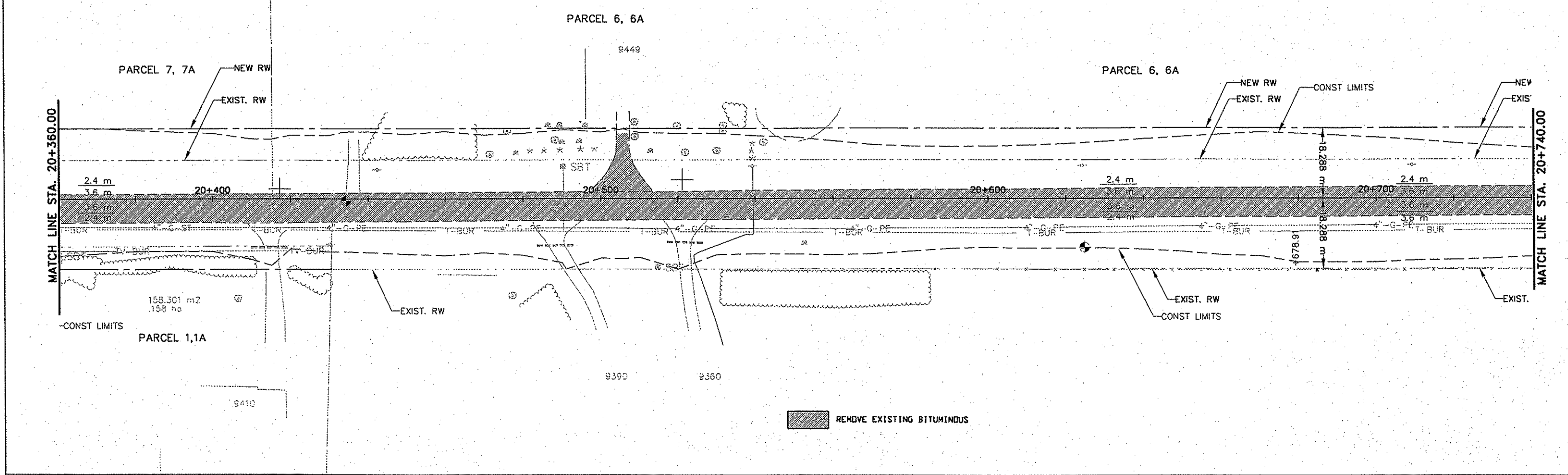
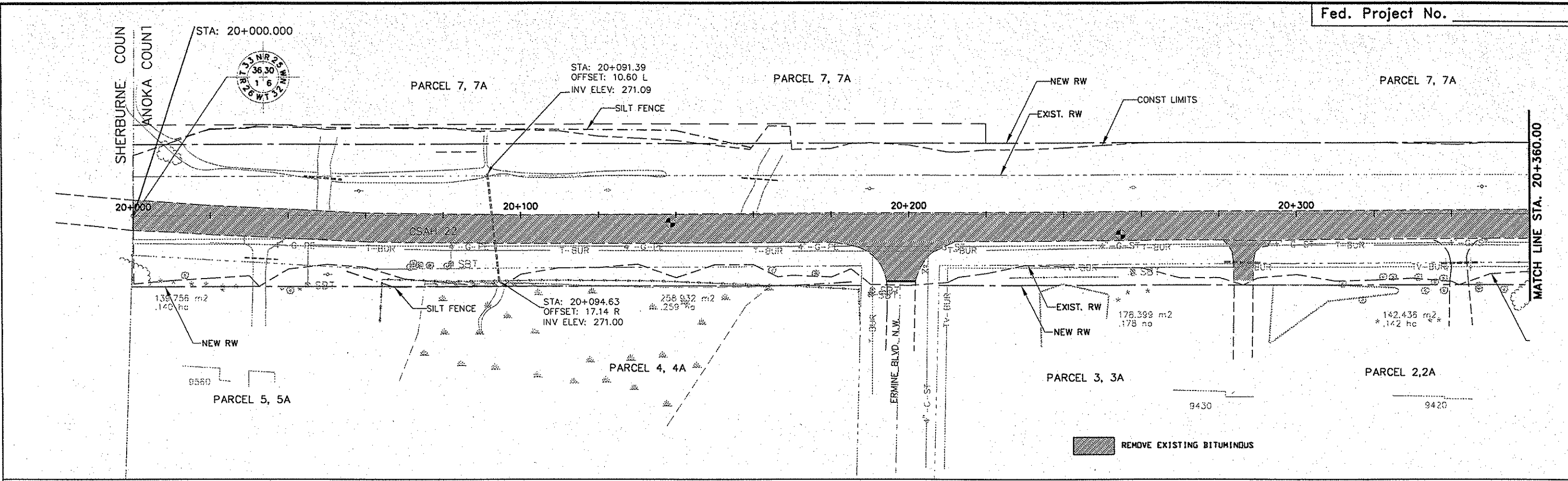

NO	DATE	BY	CKD	APPR	REVISION
13-REM22.dwg	4-21-00				7:19:41 am EST



I HEREBY CERTIFY THAT THIS PLAN WAS PREPARED BY ME OR UNDER MY DIRECT SUPERVISION AND THAT I AM A DULY REGISTERED PROFESSIONAL ENGINEER UNDER THE LAWS OF THE STATE OF MINNESOTA.

Signature

DATE 04-20-00 REG. NO. 25066

DRAWN BY: PL DATE: 00/00/98
 DESIGN BY: DVE DATE: 00/00/98
 CHECKED BY: DMF DATE: 00/00/98



ANOKA COUNTY HIGHWAY DEPT.

STATE PROJECT NO. _____
 STATE AID PROJECT NO. 02-622-27
 STATE AID PROJECT NO. 02-683-01
 COUNTY PROJECT NO. _____

EXISTING CONDITIONS AND REMOVAL PLAN
 STA 20+000.00 TO 20+740.00
 Sheet 13 of 56 Sheets

DESIGN F-1
(ALL TRAVEL LANES)

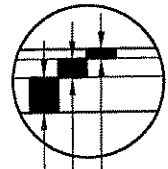

40 mm TYPE MV 4 WEARING COURSE MIXTURE-SPEC. 2350
BITUMINOUS MIXTURE DESIGNATION: MVWE45035C
80 mm TYPE LV 3 NON WEARING COURSE MIXTURE-SPEC. 2350
BITUMINOUS MIXTURE DESIGNATION: LVNW35030B
150 mm AGGREGATE BASE CLASS 5A-SPEC. 2211
TACK COAT-SPEC. 2357, TO BE APPLIED BETWEEN
ALL BITUMINOUS LIFTS. (BASE COURSE CONST. IN TWO LEFTS)

DESIGN F-2
(ALL SHOULDERS)

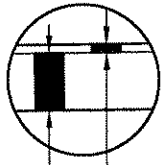

40 mm TYPE MV 4 WEARING COURSE MIXTURE-SPEC. 2350
BITUMINOUS MIXTURE DESIGNATION: MVWE45035C
VARIABLE DEPTH AGGREGATE BASE CLASS 5A
SPEC. 2211

- ① FOR SPECIAL DITCHES SEE PLAN, PROFILE AND CROSS SECTION SHEETS
- ② SEE CROSS SECTIONS FOR MODIFIED BACK SLOPE
- ③ 2.5% GRADING SLOPE IN RIGHT TURN OR BY-PASS LANE
- ④ ALL UTILITY POLES AND UNYIELDING OBJECTS SHALL BE REMOVED AND RELOCATED OUTSIDE THE RECOVERY AREA.
- ⑤ 8.456 m IN RIGHT TURN LANE OR BY-PASS.
- ⑥ 0.756 m IN RIGHT TURN LANE OR BY-PASS.
- ⑦ 4% FINISH GRADING IN SHOULDER AND 2.5% IN RIGHT TURN LANE OR BY-PASS.
- ⑧ SEE X-SEC'S. FOR VAR. WIDTH DITCH BOTTOMS.
- ⑨ SEE X-SEC'S. FOR LOCATIONS.
- ⑩ 900 mm 02-683-01, STA. 8+110 - 8+310. 600 mm PAID FOR AS SPEC. ITEM 2105.607, EXCAVATION SPECIAL.

BASE AND BITUMINOUS SECTION
TYPICAL TURN LANE \ BY-PASS

S.A.P. 02-622-27 AND S.A.P. 02-683-01
SEE PLAN AND CHART (Z), FOR LOCATION

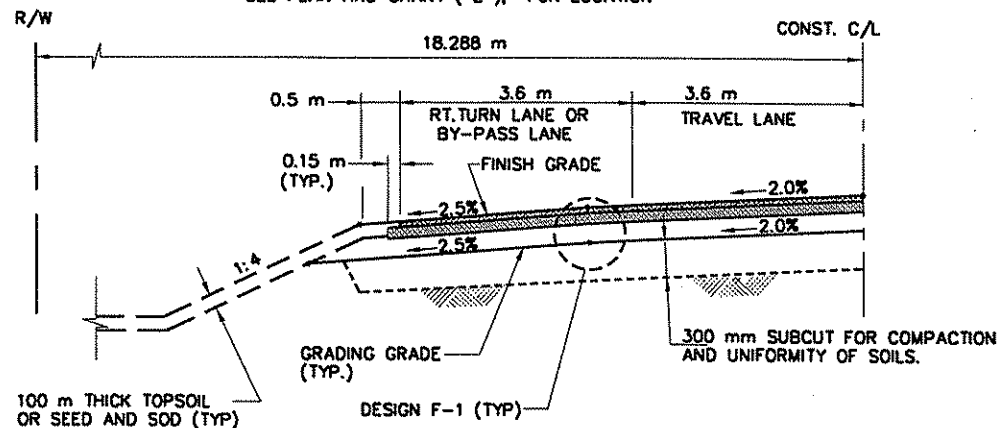

MUCK EXCAVATION

S.A.P. 02-622-27 AND S.A.P. 02-683-01
SEE X-SECTIONS FOR MUCK LOCATIONS

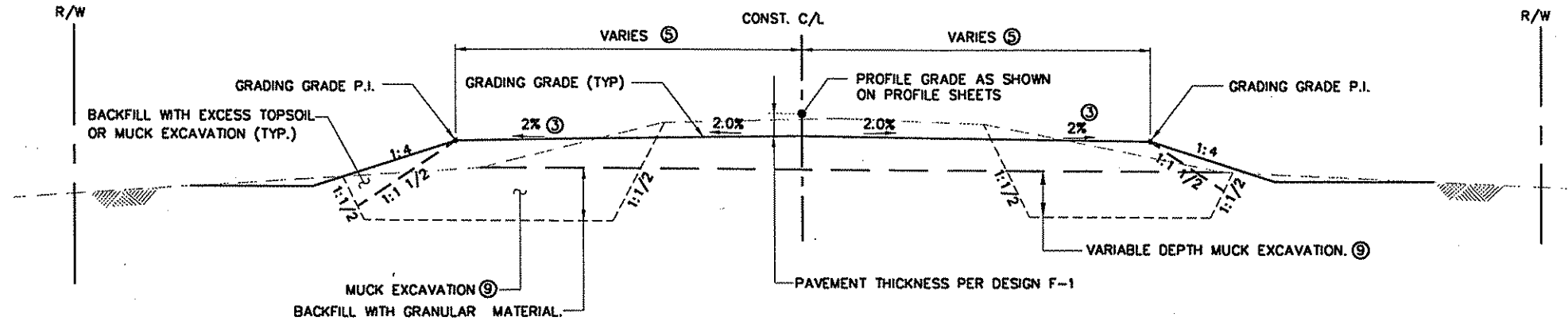

GRADING SECTION

(S.A.P. 02-622-27) STA. 20+000.000 TO STA. 20+926.650
(S.A.P. 02-683-01) STA. 7+043.927 TO STA. 8+529.138
CONST. C/L

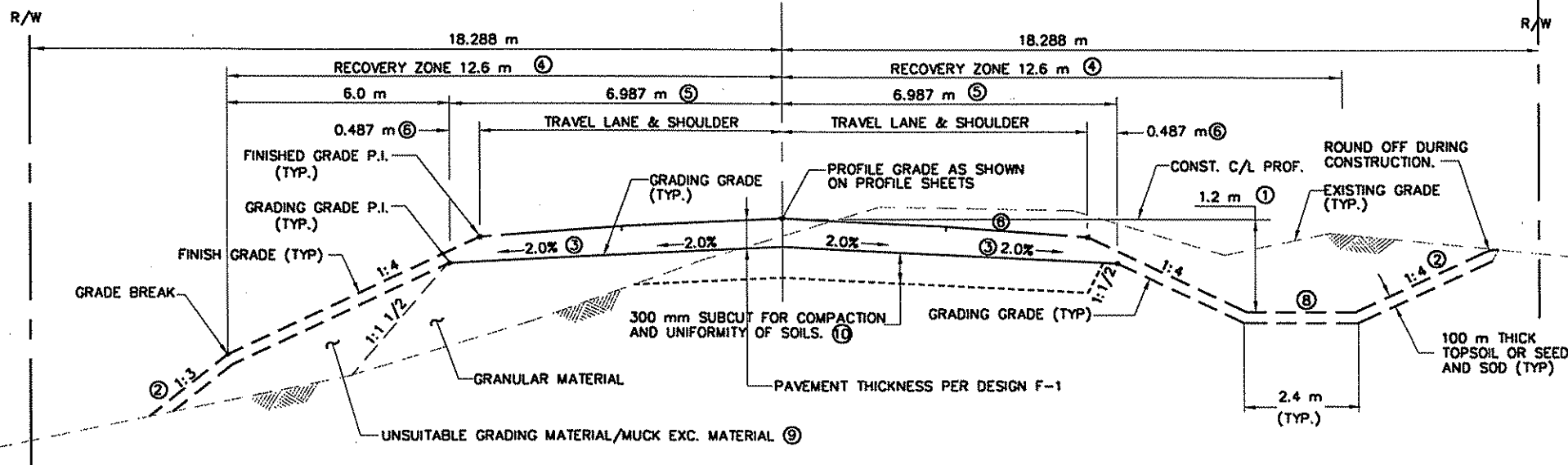

BASE AND BITUMINOUS SECTION

(S.A.P. 02-622-27) STA. 20+000.000 TO STA. 20+926.650
(S.A.P. 02-683-01) STA. 7+043.927 TO STA. 8+529.138

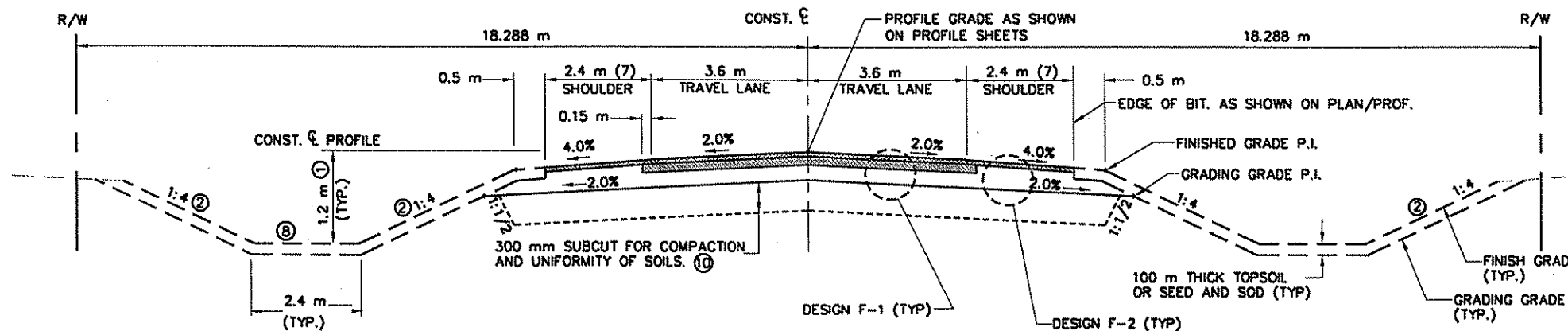

NO	DATE	BY	CKD	APPR	REVISION
11-TYP.dwg	4-26-00				1:09:52 pm EST

I HEREBY CERTIFY THAT THIS PLAN WAS PREPARED BY ME OR UNDER MY DIRECT SUPERVISION AND THAT I AM A DULY REGISTERED PROFESSIONAL ENGINEER UNDER THE LAWS OF THE STATE OF MINNESOTA.

Albert B.
DATE 04-20-00 REG. NO. 25066

DRAWN BY: MN DATE 12-22-99
DESIGN BY: MN DATE 12-22-99
CHECKED BY: LR DATE 12-22-99



ANOKA COUNTY
HIGHWAY DEPT.

STATE PROJECT NO. _____
STATE AID PROJECT NO. 02-622-27
STATE AID PROJECT NO. 02-683-01
COUNTY PROJECT NO. _____

TYPICAL SECTIONS

DESIGN F-1
(ALL TRAVEL LANES)

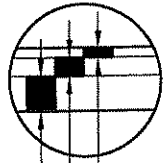

40 mm TYPE MV 4 WEARING COURSE MIXTURE-SPEC. 2350
BITUMINOUS MIXTURE DESIGNATION: MVWE45035C
80 mm TYPE LV 3 NON WEARING COURSE MIXTURE-SPEC. 2350
BITUMINOUS MIXTURE DESIGNATION: LVNW35030B
150 mm AGGREGATE BASE CLASS 5A-SPEC. 2211
TACK COAT-SPEC. 2357, TO BE APPLIED BETWEEN
ALL BITUMINOUS LIFTS. (BASE COURSE CONST. IN TWO LEFTS)

DESIGN F-2
(ALL SHOULDERS)

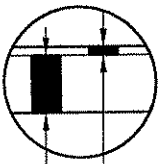

40 mm TYPE MV 4 WEARING COURSE MIXTURE-SPEC. 2350
BITUMINOUS MIXTURE DESIGNATION: MVWE45035C
VARIABLE DEPTH AGGREGATE BASE CLASS 5A
SPEC. 2211

- ① FOR SPECIAL DITCHES SEE PLAN, PROFILE AND CROSS SECTION SHEETS
- ② SEE CROSS SECTIONS FOR MODIFIED BACK SLOPE
- ③ 2.5% GRADING SLOPE IN RIGHT TURN OR BY-PASS LANE
- ④ ALL UTILITY POLES AND UNYIELDING OBJECTS SHALL BE REMOVED AND RELOCATED OUTSIDE THE RECOVERY AREA.
- ⑤ 8.456 m IN RIGHT TURN LANE OR BY-PASS.
- ⑥ 0.756 m IN RIGHT TURN LANE OR BY-PASS.
- ⑦ 4% FINISH GRADING IN SHOULDER AND 2.5% IN RIGHT TURN LANE OR BY-PASS.
- ⑧ SEE X-SEC'S. FOR VAR. WIDTH DITCH BOTTOMS.
- ⑨ SEE X-SEC'S. FOR LOCATIONS.
- ⑩ 900 mm 02-683-01, STA. 8+110 - 8+310. 600 mm PAID FOR AS SPEC. ITEM 2105.607, EXCAVATION SPECIAL.

RT. TURN LANE AND BYPASS LOCATIONS ②			
STA. TO STA.	LOC.	DESCRIPTION	
S.A.P. 02-622-27 (C.S.A.H. 22)			
20+050.250	20+211.570	RT CL	RIGHT TURN LANE
20+125.270	20+308.270	LT CL	BYPASS
20+678.910	20+809.729	RT CL	RIGHT TURN LANE
20+808.374	20+980.600	LT CL	RIGHT TURN LANE
S.A.P. 02-683-01 (C.S.A.H. 83)			
7+043.927	7+097.000	LT CL	RIGHT TURN LANE
7+279.960	7+443.539	RT CL	RIGHT TURN LANE
7+354.339	7+537.339	LT CL	RIGHT TURN LANE
7+481.124	7+645.440	RT CL	RIGHT TURN LANE
7+611.571	7+776.014	LT CL	RIGHT TURN LANE
7+858.137	8+022.458	RT CL	RIGHT TURN LANE
7+985.582	8+146.882	LT CL	RIGHT TURN LANE
8+386.709	8+530.746	RT CL	RIGHT TURN LANE

GRADING BASE AND BITUMINOUS SECTION

(S.A.P. 02-622-27) STA. 20+926.650 TO STA. 20+980.600

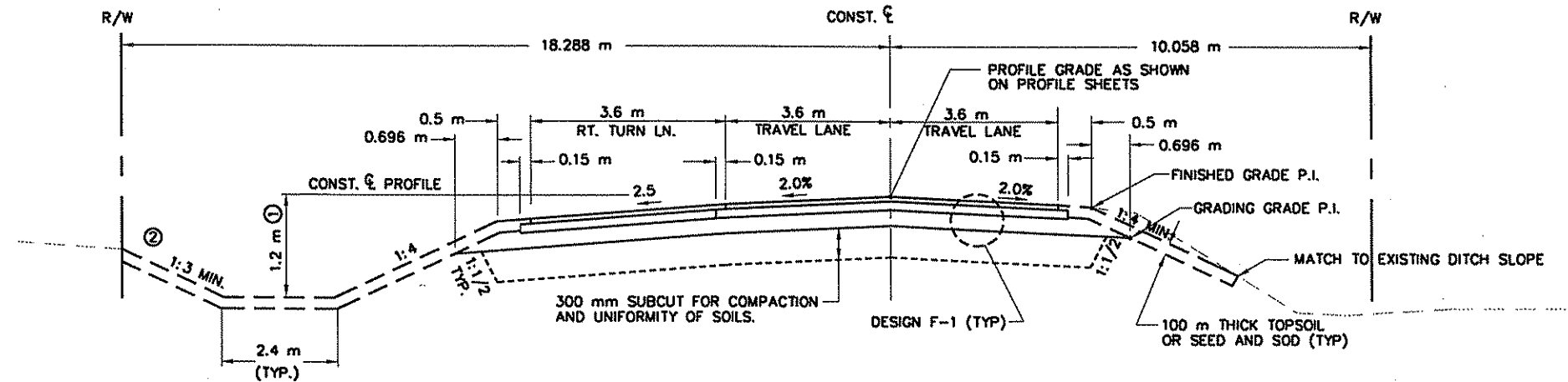

GRADING BASE AND BITUMINOUS SECTION

(S.A.P. 02-622-27) STA. 20+980.600 TO STA. 20+993.600

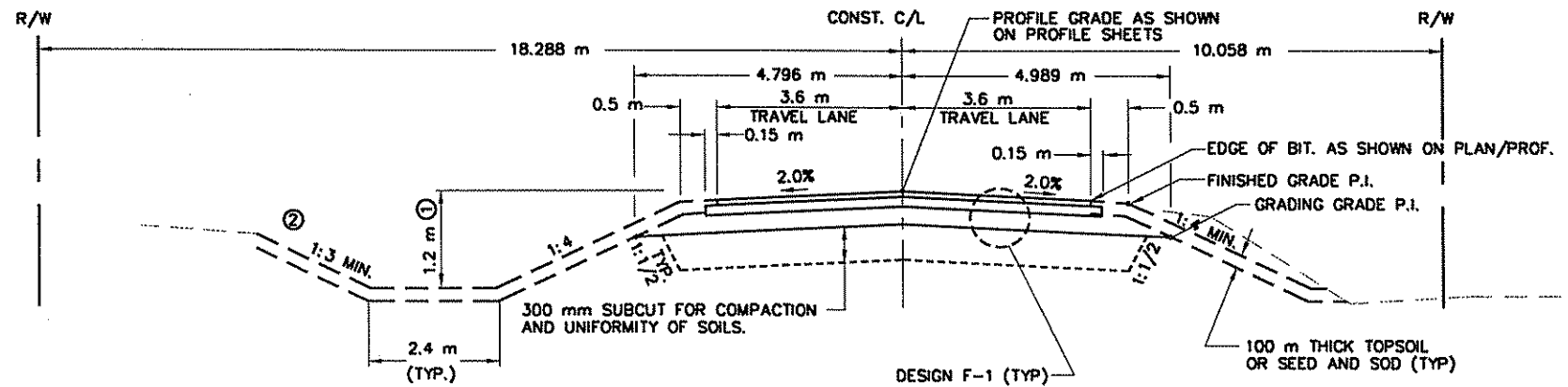

NO	DATE	BY	CKD	APPR	REVISION
NAME:	11-TYP.dwg	4-26-00	1:09:52	pm	EST



I HEREBY CERTIFY THAT THIS PLAN WAS PREPARED BY ME OR UNDER MY DIRECT SUPERVISION AND THAT I AM A DULY REGISTERED PROFESSIONAL ENGINEER UNDER THE LAWS OF THE STATE OF MINNESOTA.

Allyson

DATE 04-20-00 REG. NO. 25066

DRAWN BY: MN DATE 12-22-99
DESIGN BY: MN DATE 12-22-99
CHECKED BY: LR DATE 12-22-99



ANOKA COUNTY
HIGHWAY DEPT.

STATE PROJECT NO. _____
STATE AID PROJECT NO. 02-622-27
STATE AID PROJECT NO. 02-683-01
COUNTY PROJECT NO. _____

TYPICAL SECTIONS
Sheet 12 of 56 Sheets

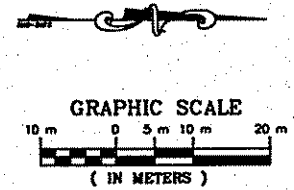
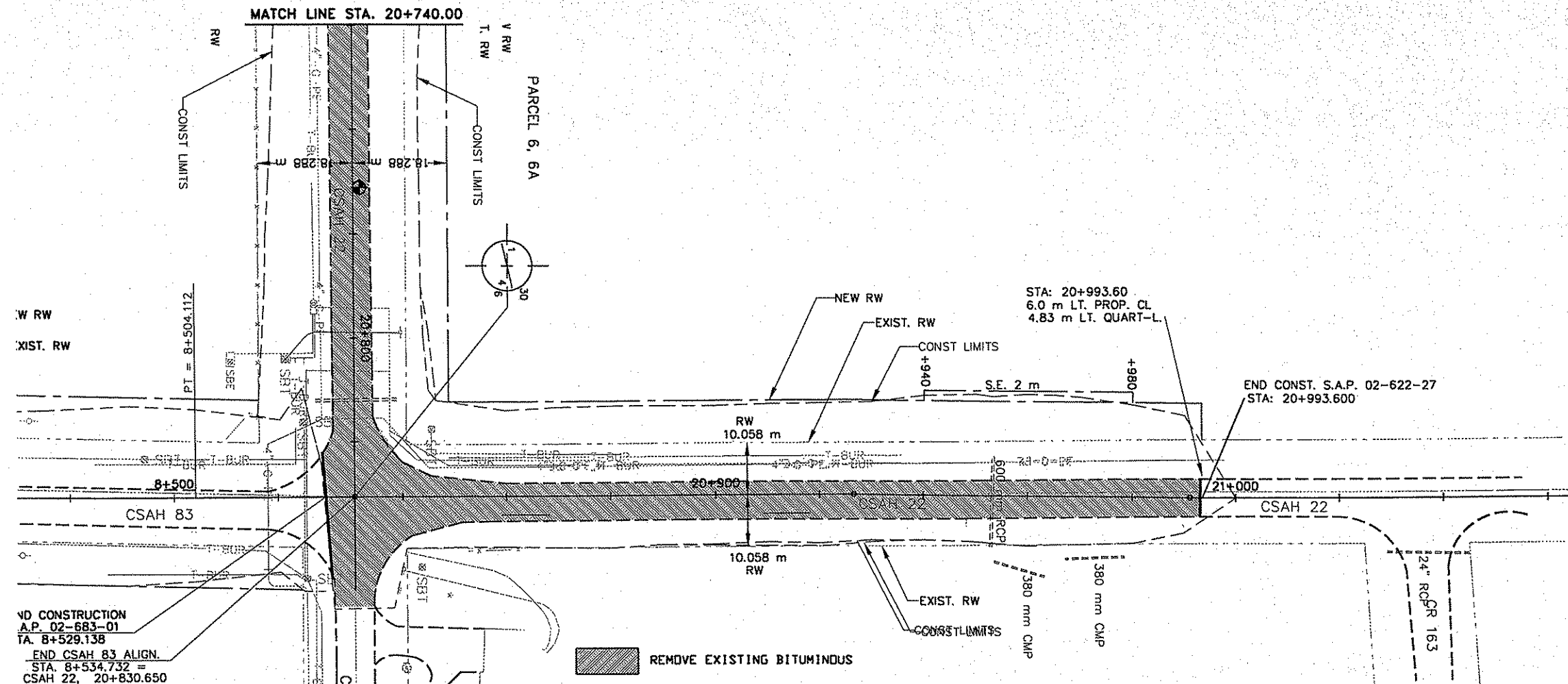

NO CONSTRUCTION
 A.P. 02-683-01
 TA. 8+529.138
 END CSAH 83 ALIGN.
 STA. 8+534.732 =
 CSAH 22, 20+830.650

REMOVE EXISTING BITUMINOUS

NO	DATE	BY	CKD	APPR	REVISION



I HEREBY CERTIFY THAT THIS PLAN WAS PREPARED BY ME OR UNDER MY DIRECT SUPERVISION AND THAT I AM A DULY REGISTERED PROFESSIONAL ENGINEER UNDER THE LAWS OF THE STATE OF MINNESOTA.

[Signature]

DATE 04-20-00 REG. NO. 25066

DRAWN BY _____ DATE 00/00/98
 DESIGN BY DWF DATE 00/00/98
 CHECKED BY DWF DATE 00/00/98

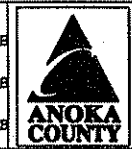

**ANOKA COUNTY
 HIGHWAY DEPT.**

STATE PROJECT NO. _____
 STATE AID PROJECT NO. 02-622-27
 STATE AID PROJECT NO. 02-683-01
 COUNTY PROJECT NO. _____

**EXISTING CONDITIONS
 AND REMOVAL PLAN**
 STA 20+740.00 TO 20+933.60
 Sheet 14 of 56 Sheets

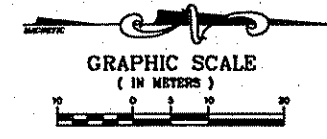
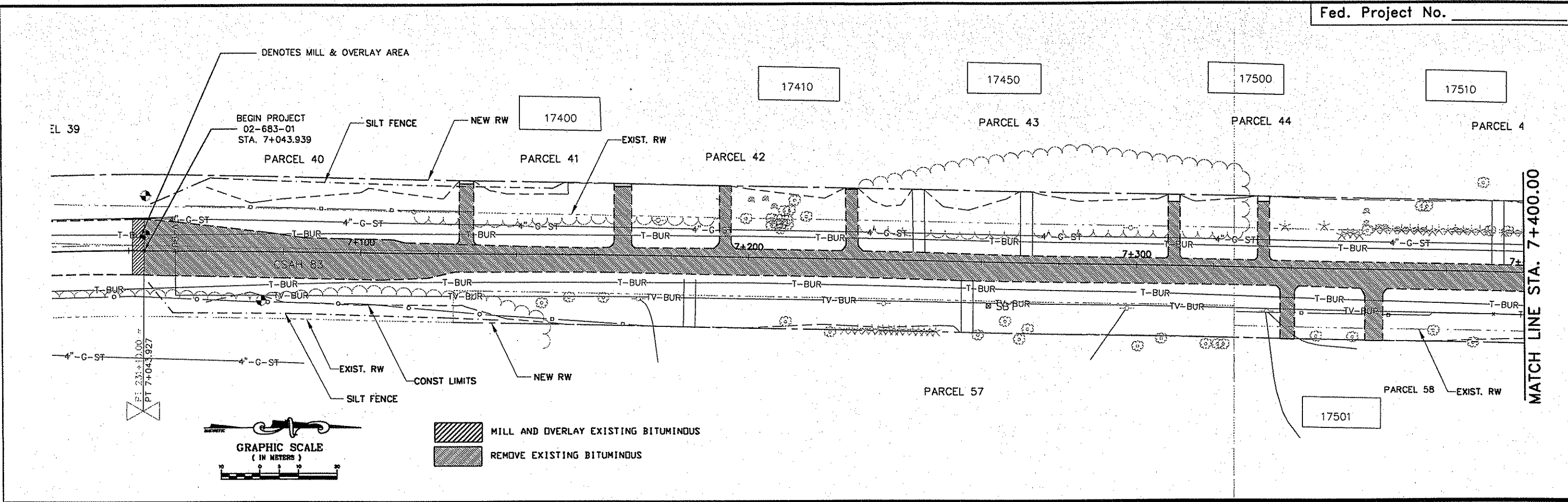

MILL AND OVERLAY EXISTING BITUMINDOUS
 REMOVE EXISTING BITUMINDOUS

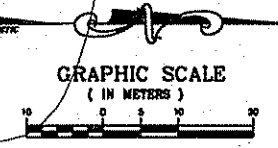
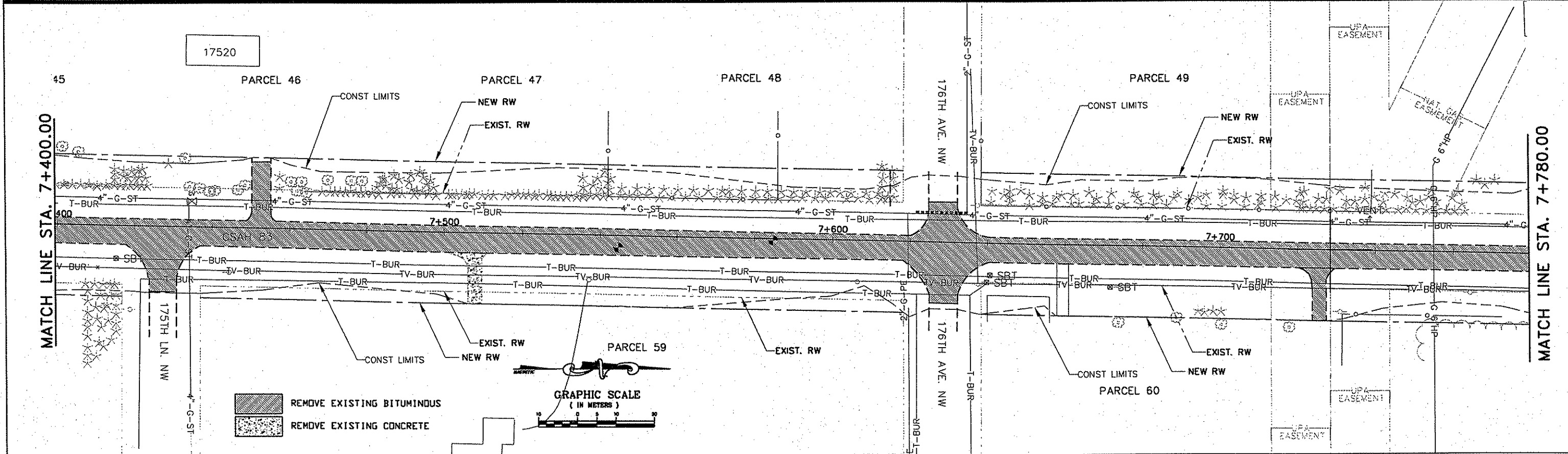

REMOVE EXISTING BITUMINDOUS
 REMOVE EXISTING CONCRETE

NO	DATE	BY	CKD	APPR	REVISION
15-REM83.dwg	4-21-00	7:22:03 am EST			



I HEREBY CERTIFY THAT THIS PLAN WAS PREPARED BY ME OR UNDER MY DIRECT SUPERVISION AND THAT I AM A DULY REGISTERED PROFESSIONAL ENGINEER UNDER THE LAWS OF THE STATE OF MINNESOTA.

 DATE 04-20-00 REG. NO. 25066

DRAWN BY: JNF DATE: 00/00/98
 DESIGN BY: JNF DATE: 00/00/98
 CHECKED BY: JNF DATE: 00/00/98



ANOKA COUNTY
 HIGHWAY DEPT.

STATE PROJECT NO. _____
 STATE AID PROJECT NO. 02-622-27
 STATE AID PROJECT NO. 02-683-01
 COUNTY PROJECT NO. _____

EXISTING CONDITIONS AND REMOVAL PLAN
 STA 7+043.940 TO 7+780.000
 Sheet 15 of 56 Sheets

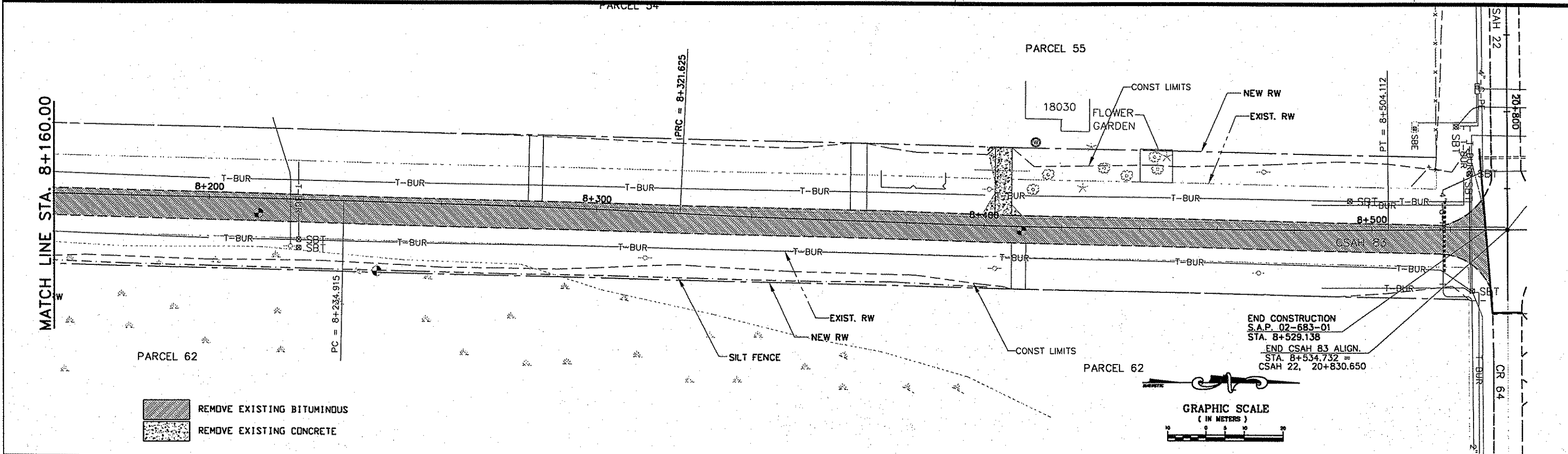
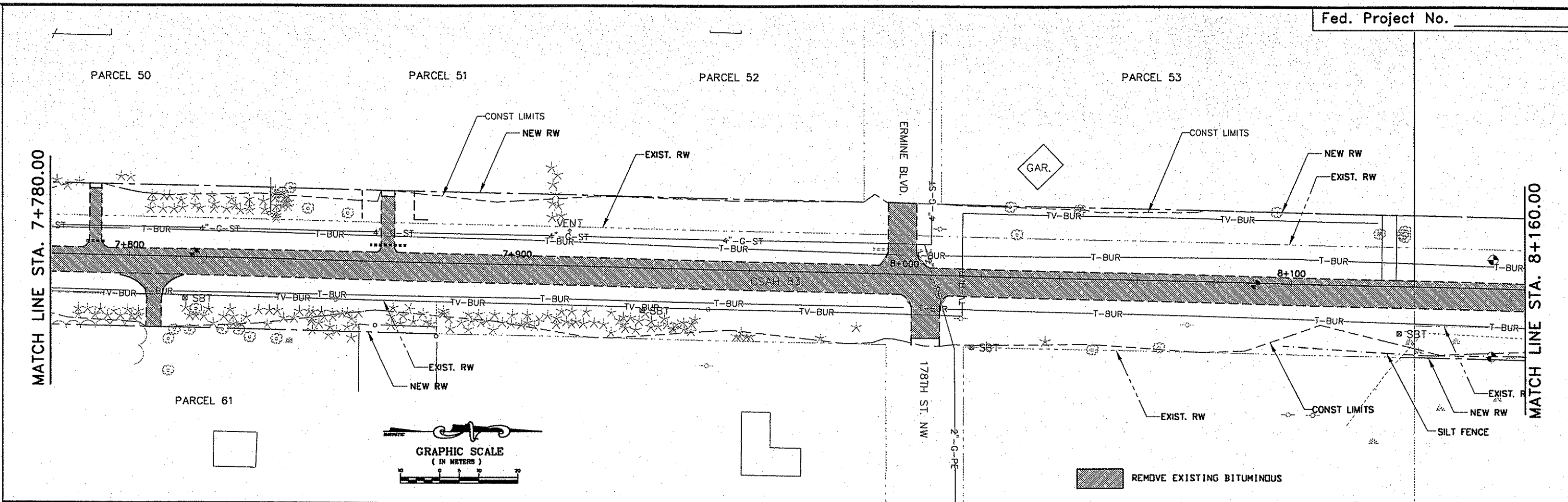

NO	DATE	BY	CKD	APPR	REVISION



I HEREBY CERTIFY THAT THIS PLAN WAS PREPARED BY ME OR UNDER MY DIRECT SUPERVISION AND THAT I AM A DULY REGISTERED PROFESSIONAL ENGINEER UNDER THE LAWS OF THE STATE OF MINNESOTA.

Allyson

DATE 04-20-00 REG. NO. 25066

DRAWN BY MW DATE 00/00/98
 DESIGN BY DWE DATE 00/00/98
 CHECKED BY DWE DATE 00/00/98



ANOKA COUNTY
 HIGHWAY DEPT.

STATE PROJECT NO. _____
 STATE AID PROJECT NO. 02-622-27
 STATE AID PROJECT NO. 02-683-01
 COUNTY PROJECT NO. _____

EXISTING CONDITIONS AND REMOVAL PLAN
 STA 7+780.000 TO 8+539.138
 Sheet 16 of 56 Sheets

CURVE # 1
 SPEED DESIGN: 90 km/h
 MAX SUPER $e = 0.053$

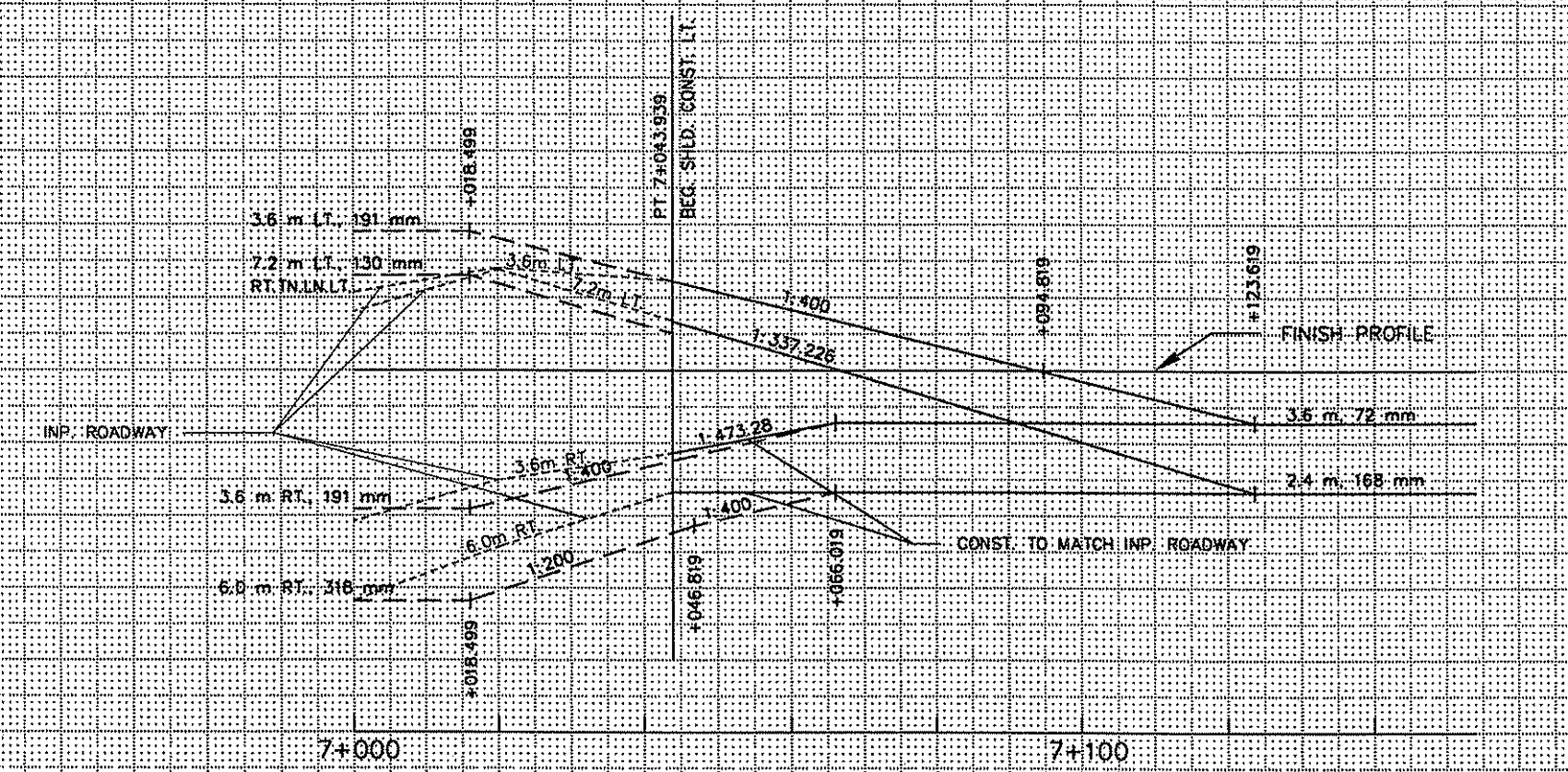

NO	DATE	BY	CKD	APPR	REVISION
18-SUPERELV.dwg	4-20-00				4:59:54 pm EST



I HEREBY CERTIFY THAT THIS PLAN WAS PREPARED BY ME OR UNDER MY DIRECT SUPERVISION AND THAT I AM A DULY REGISTERED PROFESSIONAL ENGINEER UNDER THE LAWS OF THE STATE OF MINNESOTA.

Allyson B.
 DATE 04-20-00 REG. NO. 25066

DRAWN BY _____ MN DATE 12-22-99
 DESIGN BY _____ MN DATE 12-22-99
 CHECKED BY _____ LR DATE 12-22-99



ANOKA COUNTY
 HIGHWAY DEPT.

STATE PROJECT NO. _____
 STATE AID PROJECT NO. 02-622-27
 STATE AID PROJECT NO. 02-683-01
 COUNTY PROJECT NO. _____

SUPERELEVATION
 Sheet 18 of 56 Sheets

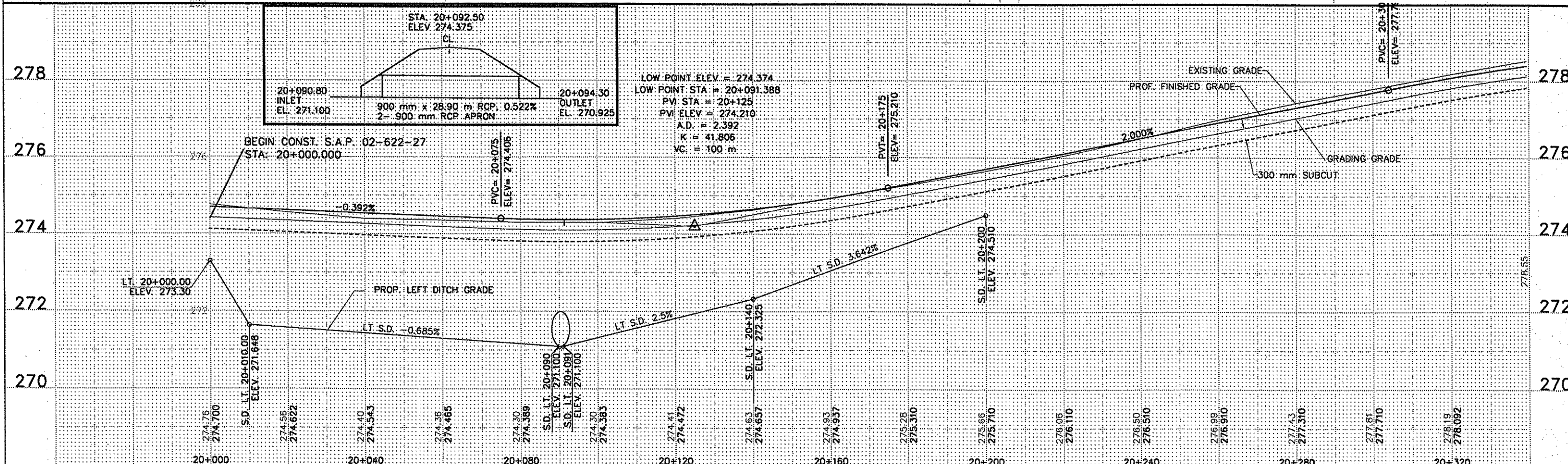
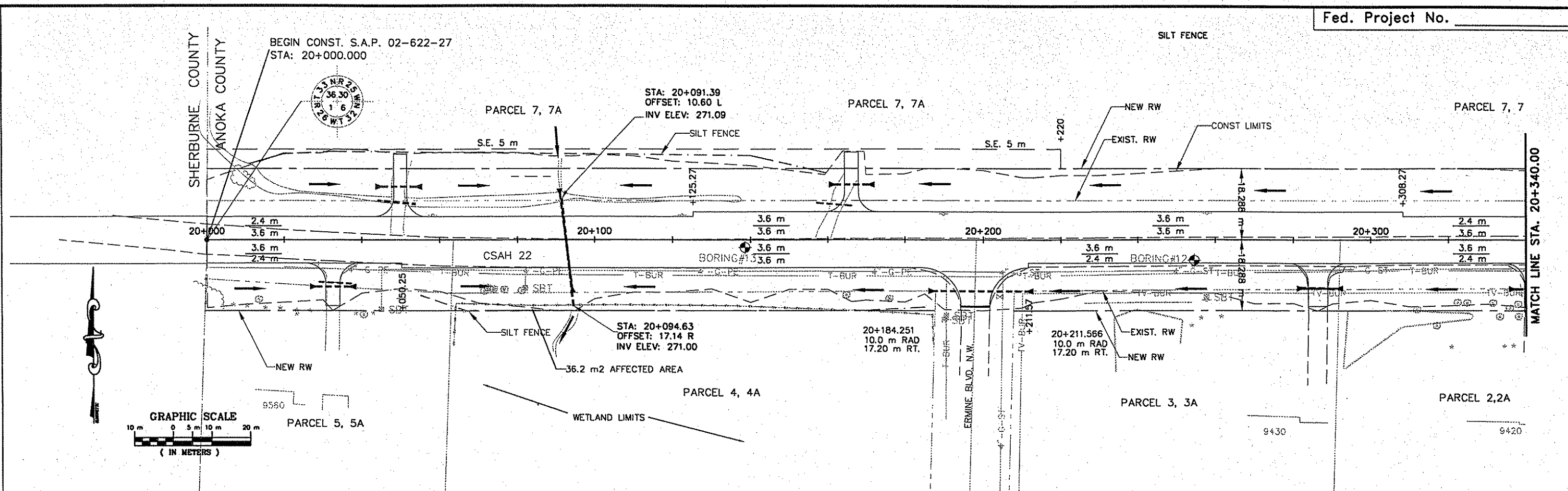

NO	DATE	BY	CKD	APPR	REVISION



I HEREBY CERTIFY THAT THIS PLAN WAS PREPARED BY ME OR UNDER MY DIRECT SUPERVISION AND THAT I AM A DULY REGISTERED PROFESSIONAL ENGINEER UNDER THE LAWS OF THE STATE OF MINNESOTA.

Albert

DATE 04-20-00 REG. NO. 25066

DRAWN BY MN DATE 00/00/98
 DESIGN BY DWE DATE 00/00/98
 CHECKED BY DWE DATE 00/00/98

ANOKA COUNTY
HIGHWAY DEPT.

STATE PROJECT NO. _____
 STATE AID PROJECT NO. 02-622-27
 STATE AID PROJECT NO. 02-683-01
 COUNTY PROJECT NO. _____

PLAN AND PROFILE
C.S.A.H 22
 STA 20+000.00 TO 20+340.00
 Sheet 19 of 56 Sheets

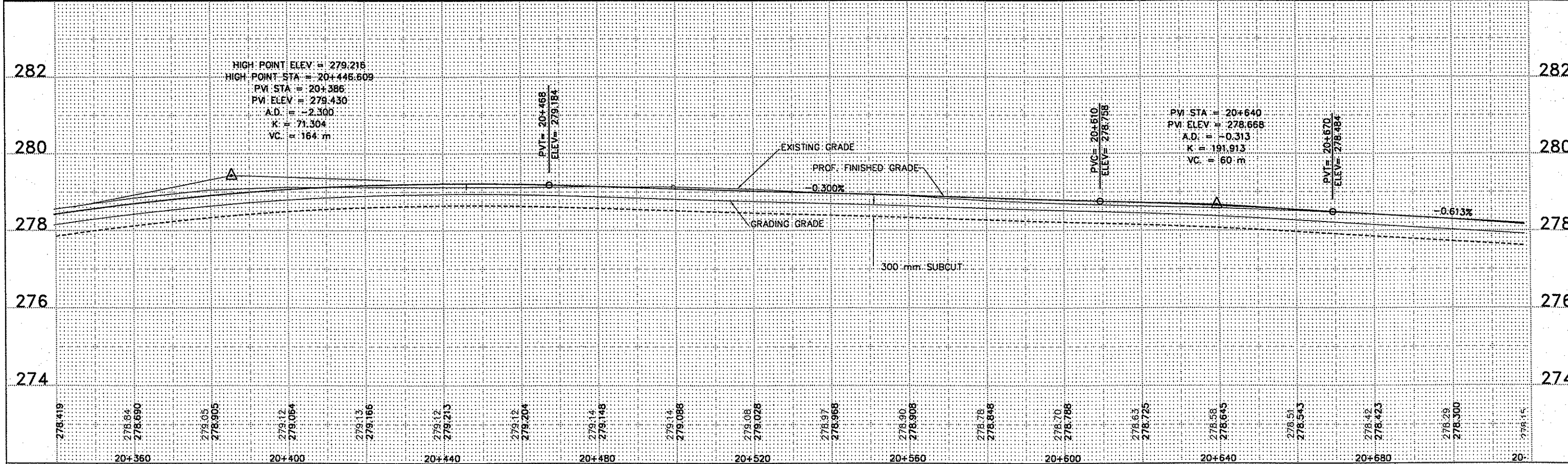
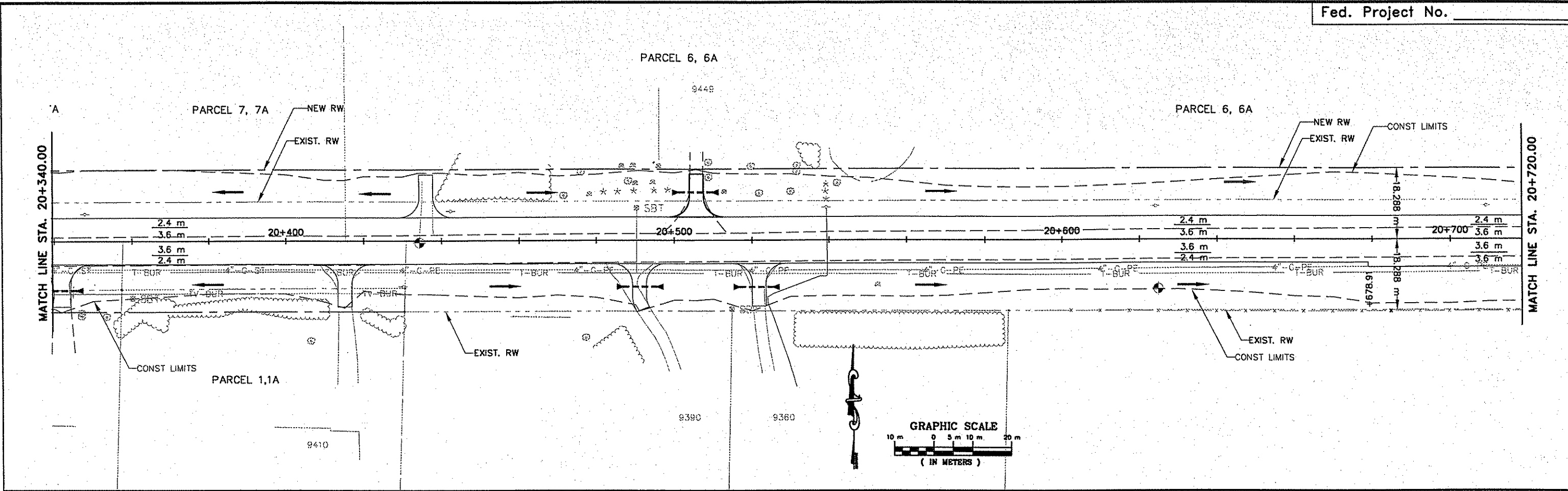

NO	DATE	BY	CHKD	APPR	REVISION



I HEREBY CERTIFY THAT THIS PLAN WAS PREPARED BY ME OR UNDER MY DIRECT SUPERVISION AND THAT I AM A DULY REGISTERED PROFESSIONAL ENGINEER UNDER THE LAWS OF THE STATE OF MINNESOTA.

[Signature]

DATE 04-20-00 REG. NO. 25066

DRAWN BY: MN DATE 00/00/98
DESIGN BY: DWE DATE 00/00/98
CHECKED BY: DWE DATE 00/00/98



ANOKA COUNTY
HIGHWAY DEPT.

STATE PROJECT NO. _____
STATE AID PROJECT NO. 02-622-27
STATE AID PROJECT NO. 02-683-01
COUNTY PROJECT NO. _____

PLAN AND PROFILE
C.S.A.H. 22
STA 20+340.00 TO 20+720.00
Sheet 20 of 56 Sheets

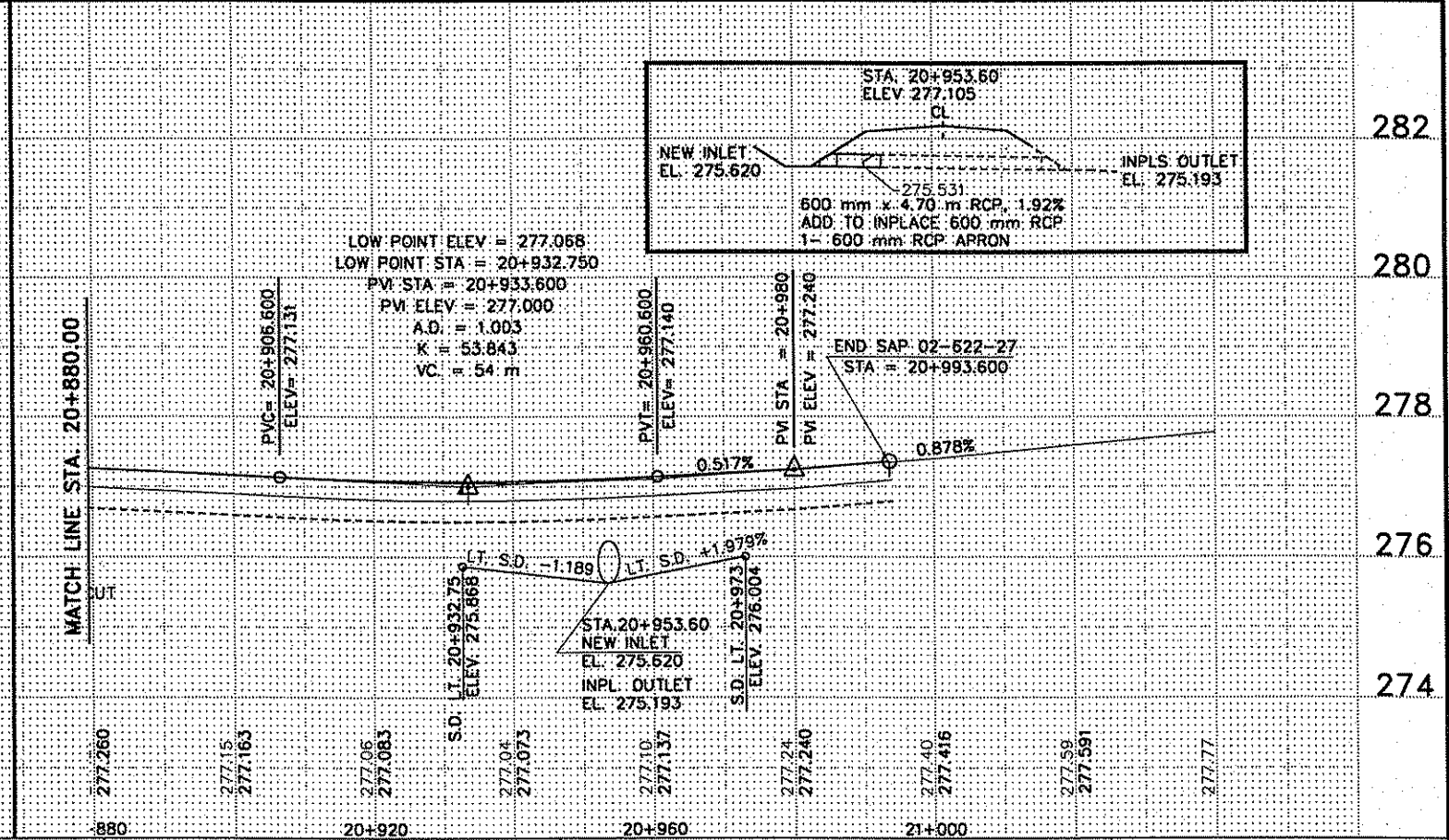
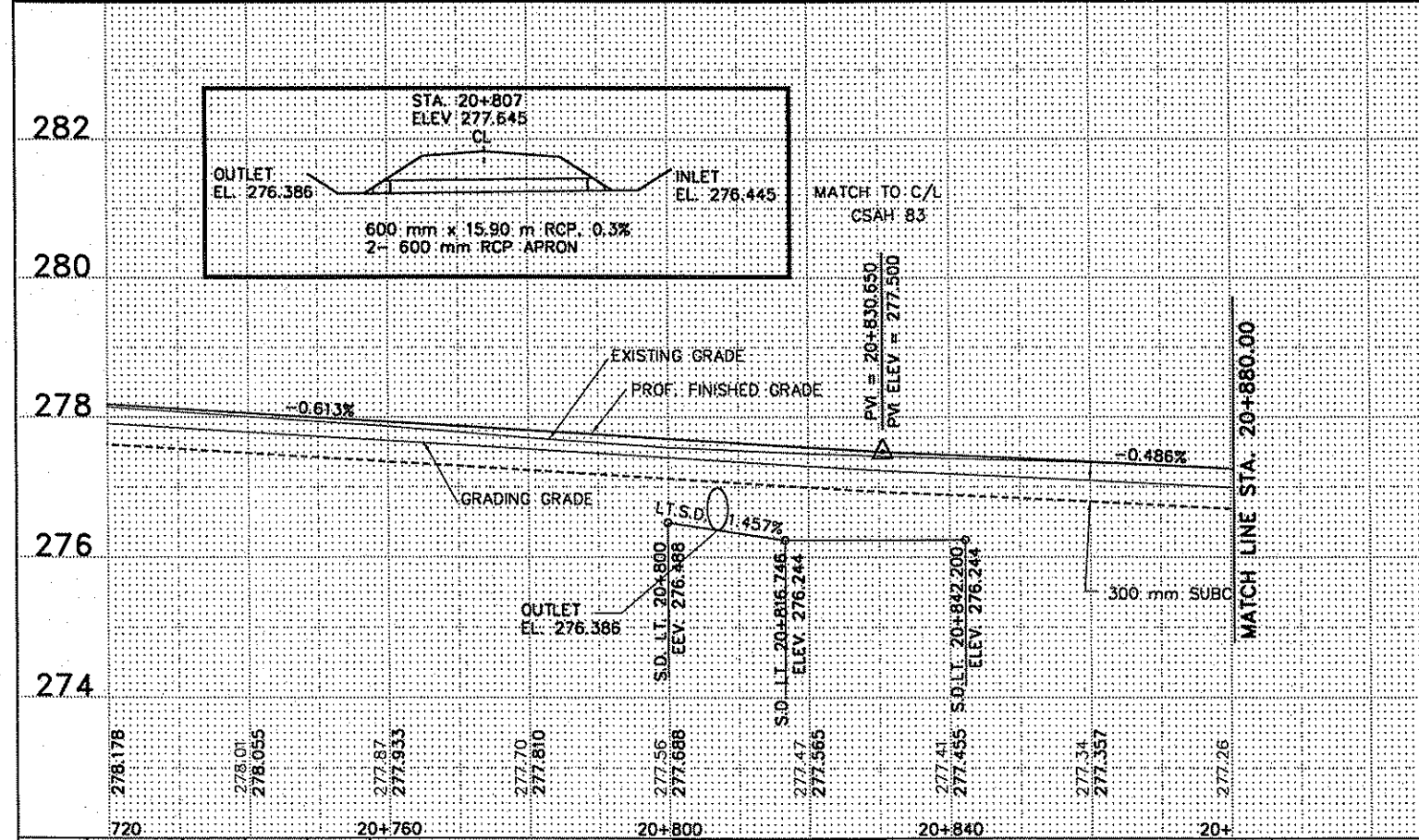
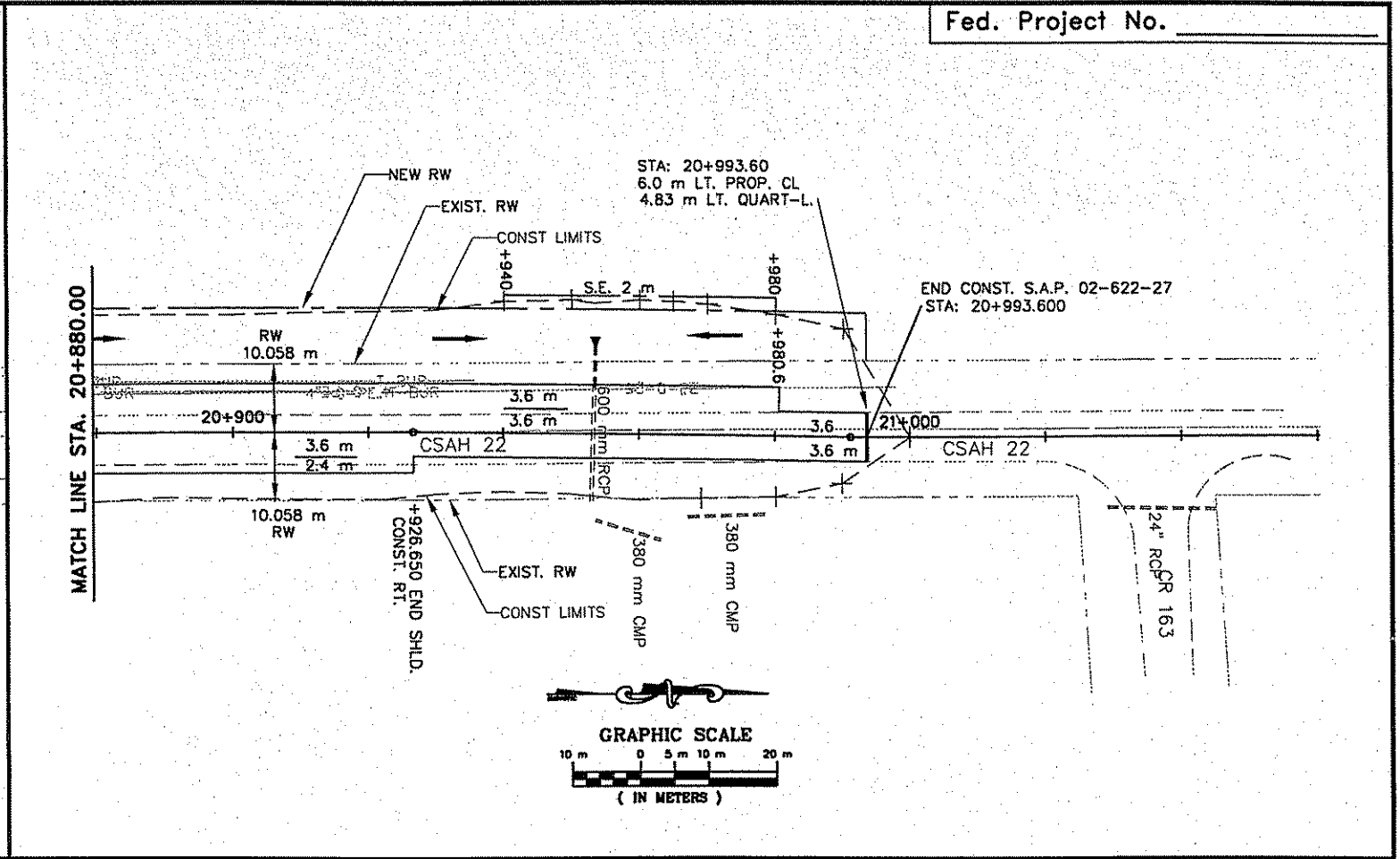
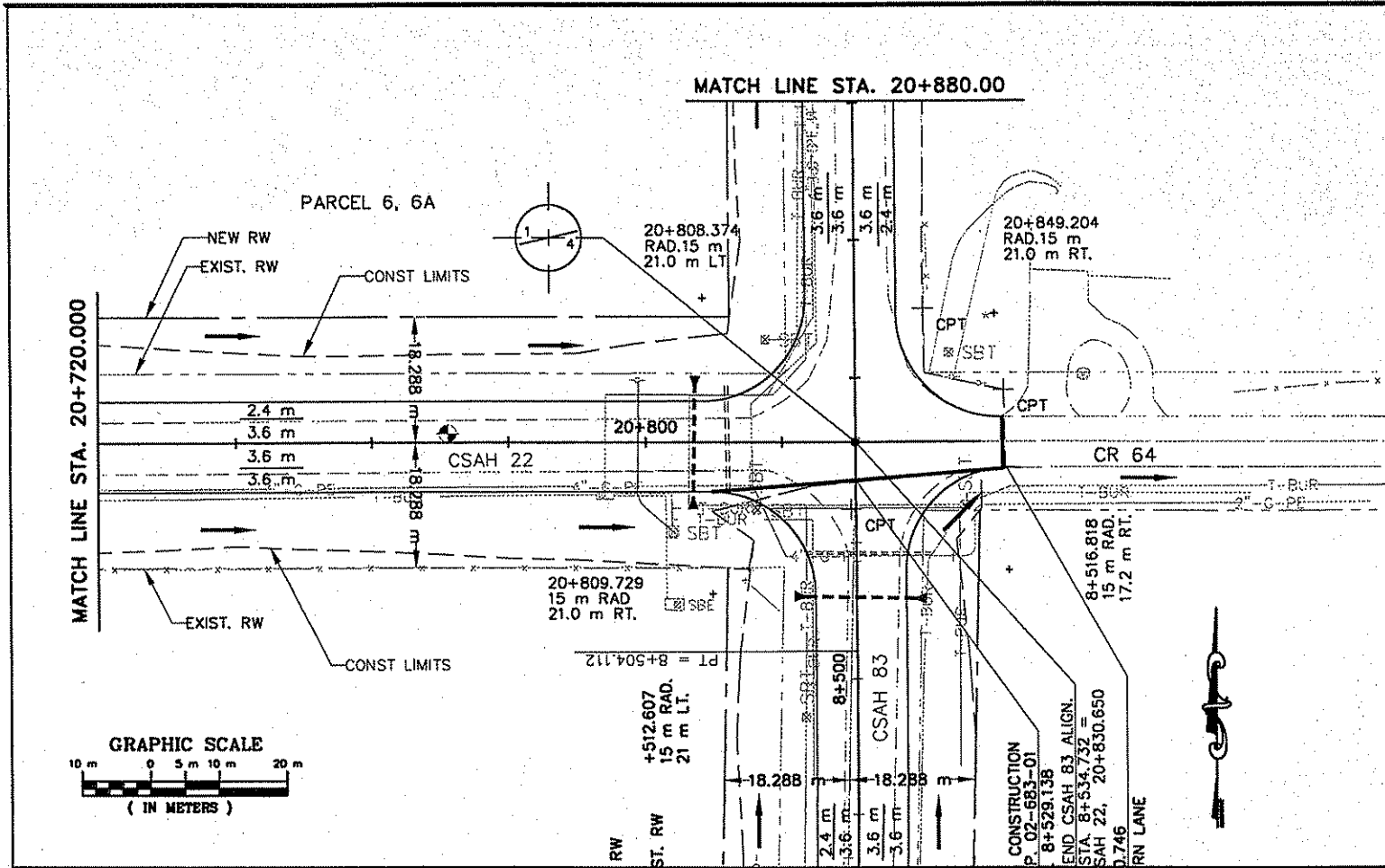

NO	DATE	BY	CKD	APPR	REVISION



I HEREBY CERTIFY THAT THIS PLAN WAS PREPARED BY ME OR UNDER MY DIRECT SUPERVISION AND THAT I AM A DULY REGISTERED PROFESSIONAL ENGINEER UNDER THE LAWS OF THE STATE OF MINNESOTA.

Allyson

DATE 04-20-00 REG. NO. 25066

DRAWN BY: MN DATE 00/00/98
 DESIGN BY: DWE DATE 00/00/98
 CHECKED BY: DWE DATE 00/00/98



ANOKA COUNTY HIGHWAY DEPT.

STATE PROJECT NO. _____
 STATE AID PROJECT NO. 02-622-27
 STATE AID PROJECT NO. 02-683-01
 COUNTY PROJECT NO. _____

PLAN AND PROFILE
 C.S.A.H. 22
 STA 20+720.00 TO 21+000.00
 Sheet 21 of 56 Sheets

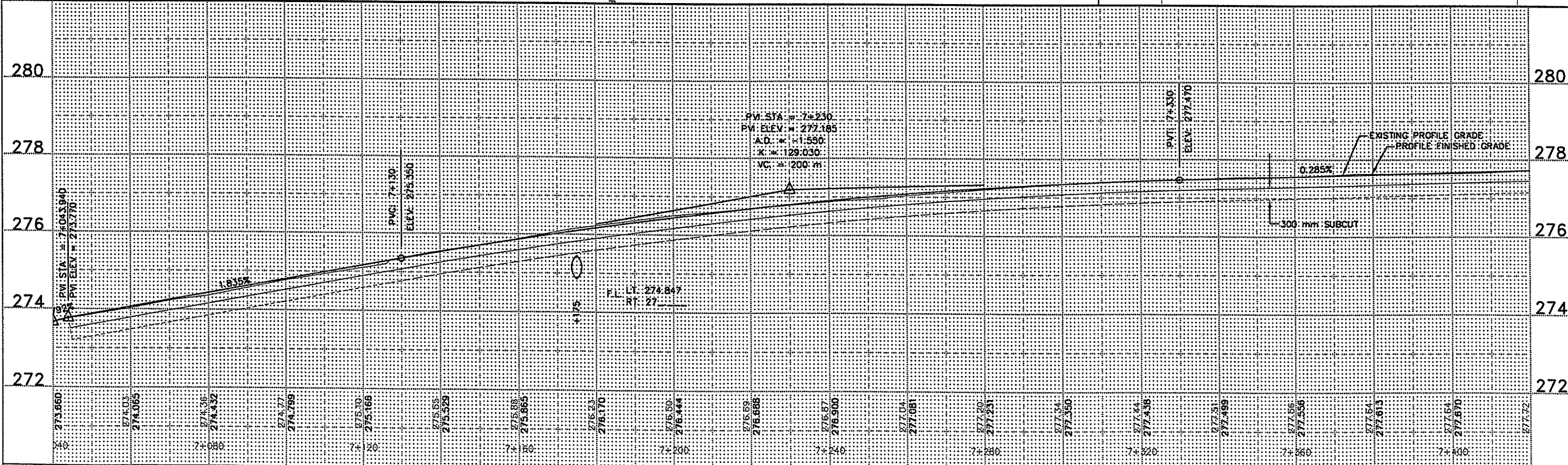
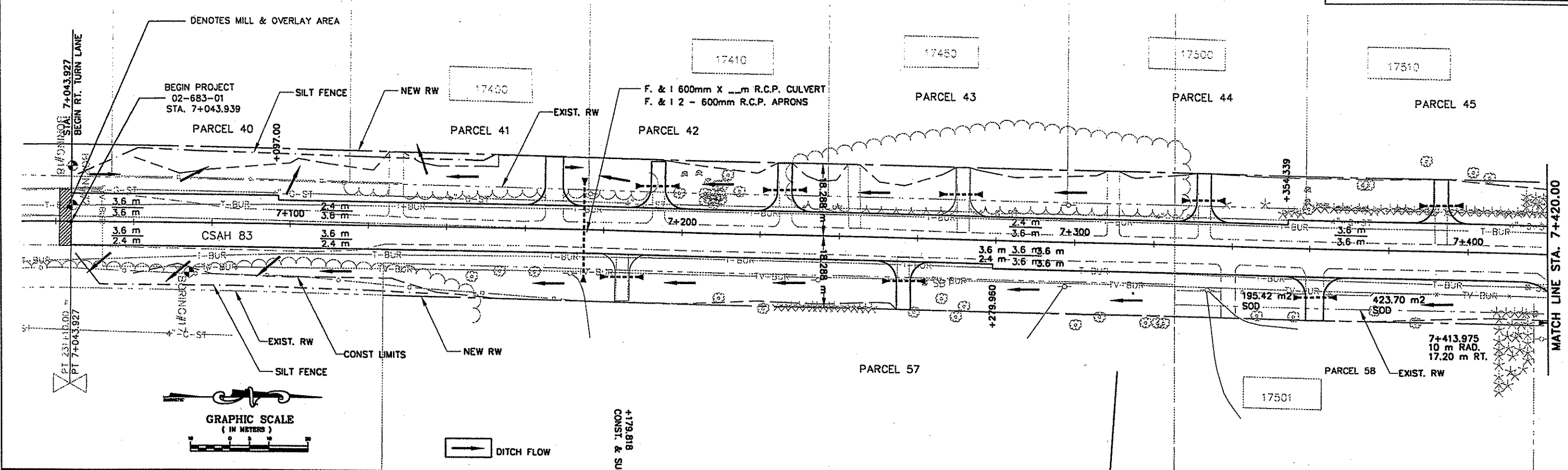

NO	DATE	BY	CHKD	APPR	REVISION

NAME: 22-PLAN83.dwg 4-20-00 5:20:07 pm EST



I HEREBY CERTIFY THAT THIS PLAN WAS PREPARED BY ME OR UNDER MY DIRECT SUPERVISION AND THAT I AM A DULY REGISTERED PROFESSIONAL ENGINEER UNDER THE LAWS OF THE STATE OF MINNESOTA.

Albert

DATE 04-20-00 REG. NO. 25066

DRAWN BY: MN DATE 00/00/98
 DESIGN BY: DME DATE 00/00/98
 CHECKED BY: DME DATE 00/00/98



ANOKA COUNTY
 HIGHWAY DEPT.

STATE PROJECT NO. _____
 STATE AID PROJECT NO. 02-622-27
 STATE AID PROJECT NO. 02-683-01
 COUNTY PROJECT NO. _____

PLAN AND PROFILE
 C.S.A.H. 83
 STA 7+109.467 TO 7+420.000
 Sheet 22 of 56 Sheets

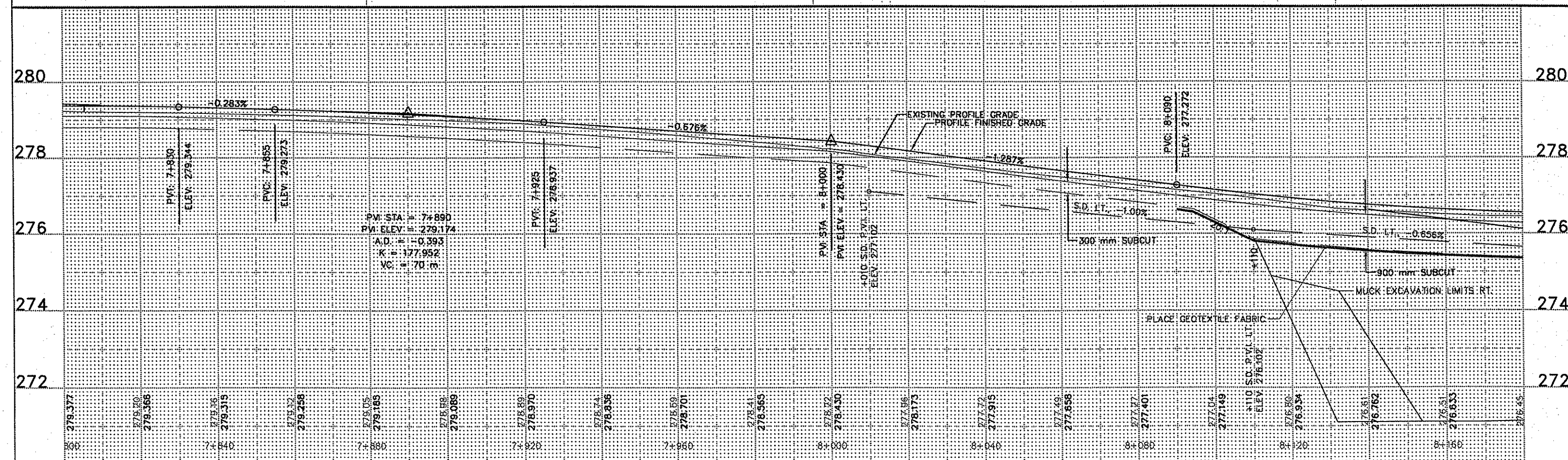
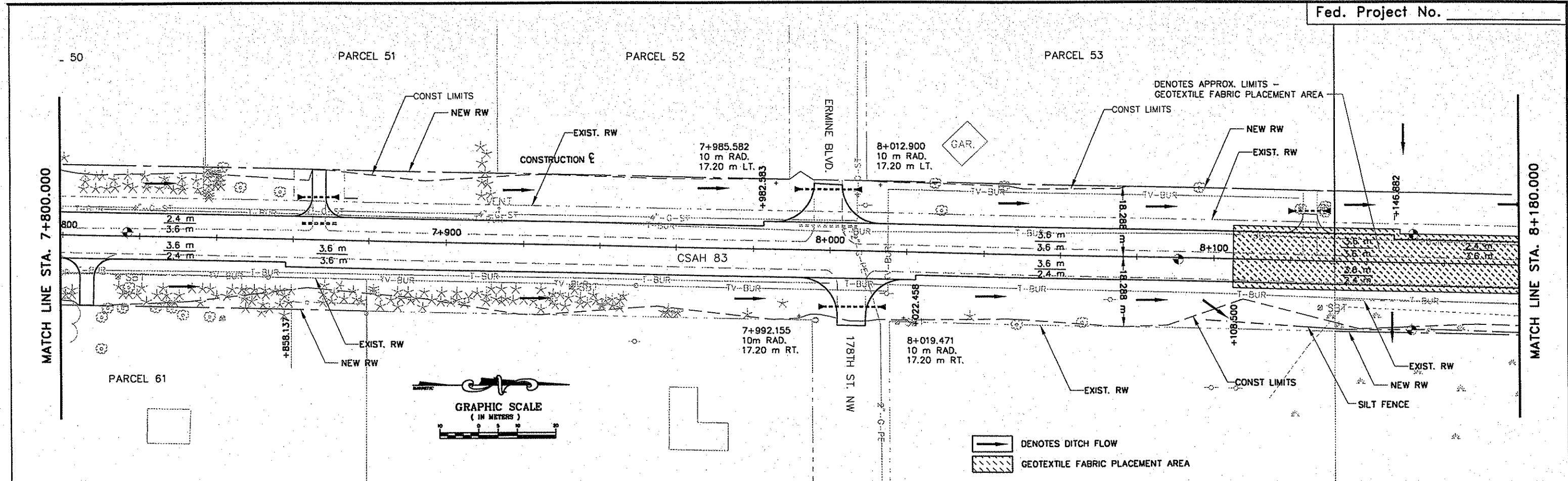

NO	DATE	BY	CKD	APPR	REVISION



I HEREBY CERTIFY THAT THIS PLAN WAS PREPARED BY ME OR UNDER MY DIRECT SUPERVISION AND THAT I AM A DULY REGISTERED PROFESSIONAL ENGINEER UNDER THE LAWS OF THE STATE OF MINNESOTA.

[Signature]

DATE 04-20-00 REG. NO. 25066

DRAWN BY: MN DATE 00/00/98
 DESIGN BY: DWE DATE 00/00/98
 CHECKED BY: DWE DATE 00/00/98

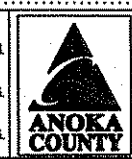

ANOKA COUNTY
 HIGHWAY DEPT.

STATE PROJECT NO. _____
 STATE AID PROJECT NO. 02-622-27
 STATE AID PROJECT NO. 02-683-01
 COUNTY PROJECT NO. _____

PLAN AND PROFILE
 C.S.A.H. 83
 STA 7+800.000 TO 8+180.000
 Sheet 24 of 56 Sheets

PARCEL 54

PARCEL 55

MATCH LINE STA. 8+180.000

F. & I. 600mm X ___m R.C.P. CULVERT
F. & I. 2 - 600mm R.C.P. APRONS

PRC = 8+321.625

INLET ①

OUTLET ②

PC = 8+234.915

+311.500

+386.709

+512.607
15 m RAD.
21 m LT.

PT = 8+504.112

CR 64

END CONSTRUCTION
S.A.P. 02-683-01
STA. 8+529.138
END CSAH 83 ALIGN.
STA. 8+534.732 =
CSAH 22, 20+830.650
STA. 8+530.746
END RT. TURN LANE

→ DENOTES DITCH FLOW
▨ GEOTEXTILE FABRIC PLACEMENT

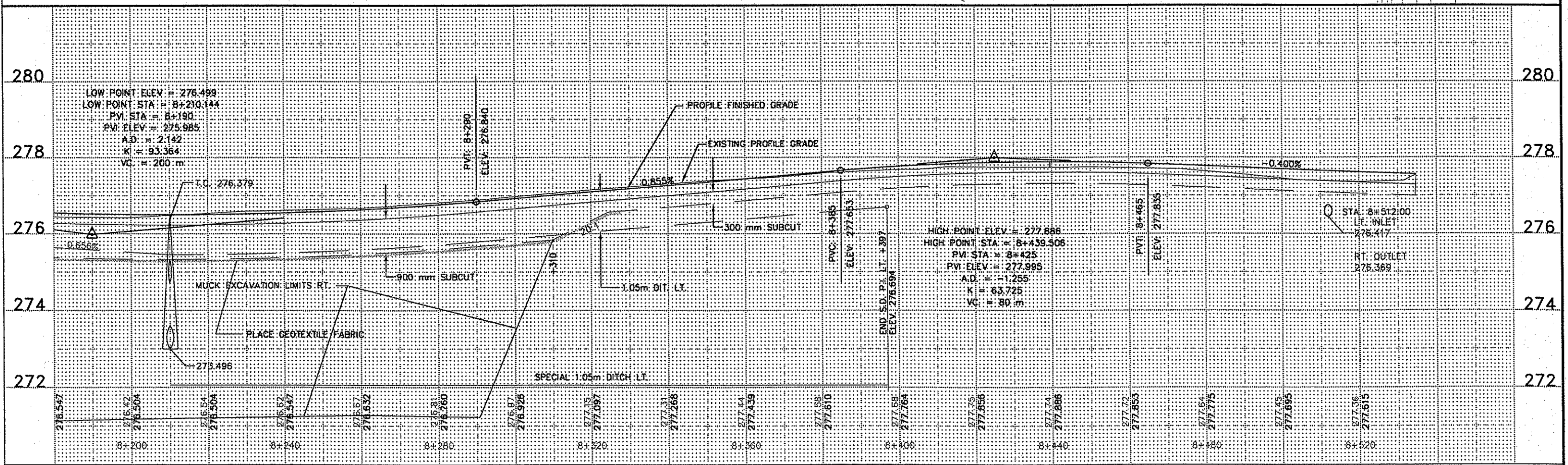
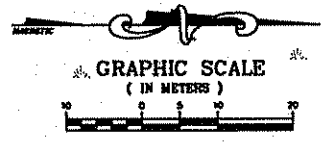

NO	DATE	BY	CRD	APPR	REVISION

NAME: 25-PLANB3.dwg 4-21-00 7:38:33 am EST



I HEREBY CERTIFY THAT THIS PLAN WAS PREPARED BY ME OR UNDER MY DIRECT SUPERVISION AND THAT I AM A DULY REGISTERED PROFESSIONAL ENGINEER UNDER THE LAWS OF THE STATE OF MINNESOTA.

[Signature]

DATE 04-20-00 REG. NO. 25066

DRAWN BY MN DATE 00/00/98
DESIGN BY DWE DATE 00/00/98
CHECKED BY DWE DATE 00/00/98



ANOKA COUNTY
HIGHWAY DEPT.

STATE PROJECT NO. _____
STATE AID PROJECT NO. 02-622-27
STATE AID PROJECT NO. 02-683-01
COUNTY PROJECT NO. _____

PLAN AND PROFILE
C.S.A.H. 83
STA 8+180.000 TO 8+529.138
Sheet 25 of 56 Sheets

DATUM 1 S.A.P. 02-622-27

STATION	AREAS		VOLUMES		CUMULATIVE VOLUMES		STATION	AREAS		VOLUMES		CUMULATIVE VOLUMES	
	Square Meters		Cubic Meters		Cubic Meters			Square Meters		Cubic Meters		Cubic Meters	
	CUT	FILL	CUT	FILL	CUT	FILL		CUT	FILL	CUT	FILL	CUT	FILL
20+000	13.426	0.495					20+505.760	15.313	0.000	74.903	0.000	8202.808	1804.027
20+010	12.107	1.135	127.667	8.151	127.667	8.151	20+510	20.018	0.000	192.309	0.000	8395.118	1804.027
20+020	16.359	8.470	142.329	48.022	269.995	56.173	20+520	18.444	0.000	181.530	0.028	8576.648	1804.054
20+030	18.477	9.972	174.180	92.207	444.175	148.380	20+530	17.862	0.006	168.225	0.237	8744.872	1804.291
20+032.500	17.074	9.942	44.438	24.892	488.614	173.272	20+540	15.783	0.042	149.396	0.384	8894.268	1804.675
20+040	16.099	10.679	124.398	77.329	613.011	250.601	20+550	14.096	0.035	132.512	1.584	9026.780	1806.259
20+050	8.156	6.322	121.278	85.007	734.289	335.608	20+560	12.406	0.282	114.820	3.203	9141.600	1809.462
20+060	14.922	11.704	115.390	90.133	849.679	425.740	20+570	10.558	0.359	99.234	4.457	9240.834	1813.919
20+070	16.874	12.531	158.976	121.177	1008.656	546.918	20+580	9.289	0.533	90.907	5.990	9331.741	1819.909
20+080	16.117	13.584	164.956	130.576	1173.611	677.494	20+590	8.893	0.665	84.020	7.002	9415.762	1826.911
20+090	12.188	12.079	141.529	128.317	1315.140	805.811	20+600	7.912	0.735	80.539	6.504	9496.301	1833.415
20+090.950	9.648	12.850	10.372	11.841	1325.512	817.653	20+610	8.196	0.566	85.143	5.032	9581.444	1838.447
20+094.300	13.359	10.309	38.537	38.791	1364.049	856.444	20+620	8.832	0.441	91.834	3.981	9673.278	1842.428
20+100	14.659	7.876	79.852	51.827	1443.901	908.270	20+630	9.534	0.356	100.871	3.566	9774.149	1845.993
20+110	13.623	7.058	141.413	74.671	1585.314	982.941	20+640	10.640	0.358	114.998	3.042	9889.147	1849.035
20+120	11.401	6.227	125.125	66.428	1710.438	1049.369	20+650	12.360	0.251	131.584	3.124	10020.731	1852.158
20+130	10.216	9.444	108.087	78.359	1818.526	1127.727	20+660	13.957	0.374	144.732	3.243	10165.462	1855.402
20+140	9.774	9.680	99.948	95.624	1918.474	1223.353	20+670	14.989	0.275	149.677	2.894	10315.140	1858.296
20+150	9.302	8.834	95.377	92.573	2013.851	1315.921	20+680	14.946	0.304	144.577	3.543	10459.716	1861.839
20+160	10.793	1.854	100.472	53.441	2114.323	1369.364	20+690	13.969	0.404	134.797	2.635	10594.513	1864.474
20+166.200	8.626	7.977	60.197	30.475	2174.520	1399.840	20+700	12.990	0.123	123.864	2.227	10718.378	1866.701
20+170	9.975	5.202	35.341	25.039	2209.861	1424.879	20+710	11.783	0.323	110.329	3.941	10828.706	1870.642
20+180	14.999	3.760	124.866	44.811	2334.727	1469.690	20+720	10.283	0.465	96.554	5.391	10925.260	1876.033
20+185	14.948	3.802	74.867	18.906	2409.594	1488.596	20+730	9.028	0.613	85.266	7.345	11010.526	1883.377
20+190	12.982	3.674	69.827	18.691	2479.422	1507.287	20+740	8.025	0.856	80.299	10.895	11090.825	1894.272
20+200	13.900	3.375	134.414	35.244	2613.836	1542.531	20+750	8.034	1.323	81.106	9.911	11171.931	1904.183
20+210	13.720	3.288	138.103	33.312	2751.939	1575.844	20+760	8.187	0.659	82.590	6.740	11254.521	1910.923
20+212.800	13.171	3.226	37.648	9.119	2789.587	1584.963	20+770	8.331	0.689	85.696	5.771	11340.217	1916.694
20+220	13.053	3.047	94.406	22.584	2883.993	1607.547	20+780	8.808	0.466	85.757	4.370	11425.974	1921.064
20+230	12.763	2.466	129.081	27.566	3013.074	1635.113	20+790	8.343	0.408	90.443	3.580	11516.417	1924.644
20+240	14.265	1.413	135.142	19.397	3148.216	1654.509	20+800	9.745	0.308	91.932	4.124	11608.349	1928.768
20+250	16.277	1.098	152.709	12.555	3300.925	1667.064	20+810	8.641	0.517	17.281	1.259	11625.630	1930.027
20+260	14.779	1.706	155.280	14.017	3456.205	1681.081	20+812	8.640	0.741	78.703	4.841	11704.333	1934.868
20+270	20.396	0.923	175.877	13.143	3632.083	1694.225	20+820	11.036	0.469	95.858	4.626	11800.191	1939.494
20+280	22.562	0.683	214.790	8.026	3846.872	1702.251	20+830	8.135	0.456	109.209	2.281	11909.400	1941.775
20+286.320	21.135	0.587	138.081	4.013	3984.953	1708.264	20+840	13.706	0.000	116.693	2.398	12026.093	1944.174
20+290	25.201	0.531	85.258	2.058	4070.211	1708.322	20+850	9.632	0.480	101.021	4.064	12127.113	1948.237
20+300	24.720	0.396	249.606	4.636	4319.817	1712.958	20+860	10.572	0.333	125.504	1.691	12252.618	1949.928
20+310	23.655	0.669	241.874	5.324	4561.691	1718.282	20+870	14.529	0.005	135.981	0.191	12388.599	1950.119
20+320	23.011	0.644	233.330	6.566	4795.021	1724.848	20+880	12.667	0.033	125.313	0.357	12513.912	1950.476
20+330	22.330	0.686	226.707	6.651	5021.727	1731.499	20+890	12.395	0.038	138.538	0.192	12652.450	1950.668
20+340	24.804	0.505	235.670	5.952	5257.397	1737.451	20+900	15.312	0.000	139.576	0.190	12792.026	1950.858
20+341.850	18.488	0.477	40.045	0.909	5297.442	1738.359	20+910	12.603	0.038	125.259	0.539	12917.285	1951.396
20+350	20.596	0.438	159.266	3.729	5456.708	1742.088	20+920	12.449	0.070	114.676	1.328	13031.961	1952.724
20+360	20.891	0.587	207.431	5.122	5664.139	1747.211	20+930	10.486	0.196	116.532	1.144	13148.493	1953.868
20+370	18.933	0.717	199.120	6.520	5863.259	1753.731	20+940	12.820	0.033	117.796	8.411	13266.289	1952.280
20+380	17.998	0.827	184.659	7.719	6047.918	1761.450	20+950	10.739	1.649	36.947	6.237	13303.236	1968.516
20+390	16.769	0.798	173.835	8.123	6221.753	1769.573	20+953.400	10.995	2.019	73.682	10.129	13376.918	1978.645
20+400	15.618	0.775	161.934	7.866	6383.687	1777.439	20+960	11.333	1.050	56.514	4.062	13433.432	1982.707
20+410	14.755	0.736	151.867	7.557	6535.554	1784.996	20+965	11.273	0.575	54.154	2.949	13487.586	1985.656
20+415.100	12.468	0.806	69.420	3.932	6604.975	1788.928	20+970	10.389	0.605	97.170	6.265	13584.755	1991.921
20+420	13.050	0.855	62.520	4.069	6667.495	1792.998	20+980	9.045	0.648	81.277	3.245	13666.033	1995.166
20+430	12.388	0.756	127.192	8.054	6794.686	1801.051	20+990	7.211	0.001	36.053	0.012	13702.085	1995.178
20+436	10.880	0.000	69.805	2.267	6864.492	1803.318	21+000	0.000	0.001	0.000	0.009	13702.085	1995.187
20+440	19.108	0.000	59.976	0.000	6924.468	1803.318	21+010	0.000	0.001	0.000	0.003	13702.085	1995.191
20+450	21.468	0.000	202.880	0.000	7127.348	1803.318	21+020	0.000	0.000	0.000	0.000	13702.085	1995.191
20+460	19.224	0.000	203.458	0.000	7330.806	1803.318	21+030	0.000	0.000	0.000	0.000	13702.085	1995.191
20+470	14.822	0.033	170.229	0.167	7501.035	1803.485	21+040	0.000	0.000	0.000	0.000	13702.085	1995.191
20+480	16.422	0.025	156.220	0.292	7657.255	1803.777	21+050	0.000	0.000	0.000	0.000	13702.085	1995.191
20+490	23.010	0.000	197.161	0.125	7854.417	1803.902							
20+491	14.552	0.025	18.781	0.013	7873.198	1803.914							
20+500	19.664	0.000	153.972	0.113	8027.170	1804.027							
			100.735	0.000	8127.905	1804.027							

DATUM 1 S.A.P. 02-683-01

STATION	AREAS		VOLUMES		CUMULATIVE VOLUMES		STATION	AREAS		VOLUMES		CUMULATIVE VOLUMES	
	Square Meters		Cubic Meters		Cubic Meters			Square Meters		Cubic Meters		Cubic Meters	
	CUT	FILL	CUT	FILL	CUT	FILL		CUT	FILL	CUT	FILL	CUT	FILL
7+043.000	1.00	1.00					7+711.530	16.00	0.00	184.00	45.00	7803.000	3276.000
7+044.000	0.00	0.00					7+725.550	5.00	0.00	78.00	20.00	7881.000	3296.000
7+060.000	6.00	0.00					7+731.950	14.00	0.00	152.00	45.00	8033.000	3341.000
7+071.440	2.00	7.00					7+742.010	9.00	1.00	158.00	74.00	8191.000	3415.000
7+080.000	3.00	3.00					7+757.250	5.00	2.00	136.00	79.00	8327.000	3494.000
7+100.000	5.00	4.00					7+772.490	6.00	2.00	136.00	56.00	8463.000	3550.000
7+101.920	3.00	10.00					7+784.380	10.00	1.00	62.00	20.00	8525.000	3570.000
7+119.920	0.00	0.00					7+791.390	3.00	0.00	128.00	35.00	8653.000	3605.000
7+126.000	3.00	7.00					7+802.970	14.00	0.00	30.00	7.00	8683.000	3612.000
7+127.220	3.00	0.00					7+805.710	3.00	0.00	30.00	9.00	8713.000	3621.000
7+137.580	8.00	5.00					7+809.070	9.00	0.00	365.00	103.00	9078.000	3724.000
7+153.130	1												

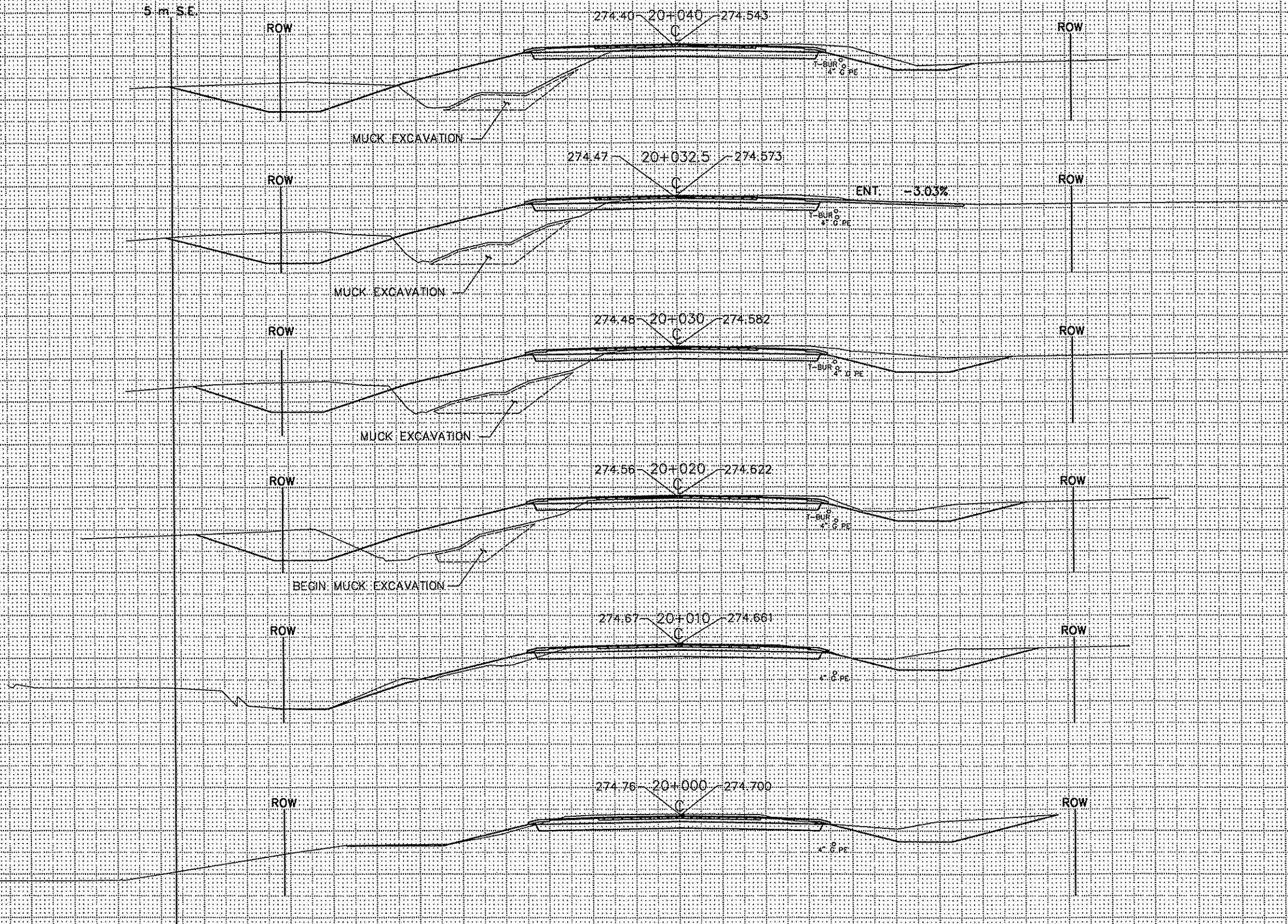

NO	DATE	BY	CKD	APPR	REVISION
1	4-20-00				

NAME: X-Sec22.dwg 4-20-00 1:16:29 pm EST



I HEREBY CERTIFY THAT THIS PLAN WAS PREPARED BY ME OR UNDER MY DIRECT SUPERVISION AND THAT I AM A DULY REGISTERED PROFESSIONAL ENGINEER UNDER THE LAWS OF THE STATE OF MINNESOTA.

Albert

DATE 04/20/00 REG. NO. 25066

DRAWN BY: JMN DATE 12-22-99
 DESIGN BY: JMN DATE 12-22-99
 CHECKED BY: JLR DATE 12-22-99



ANOKA COUNTY
 HIGHWAY DEPT.

STATE PROJECT NO. _____
 STATE AID PROJECT NO. 02-622-27
 STATE AID PROJECT NO. 02-683-01
 COUNTY PROJECT NO. _____

CROSS-SECTION
 C.S.A.H 22
 STA. 20+000.000 TO 20+040.000
 Sheet 27 of 56 Sheets

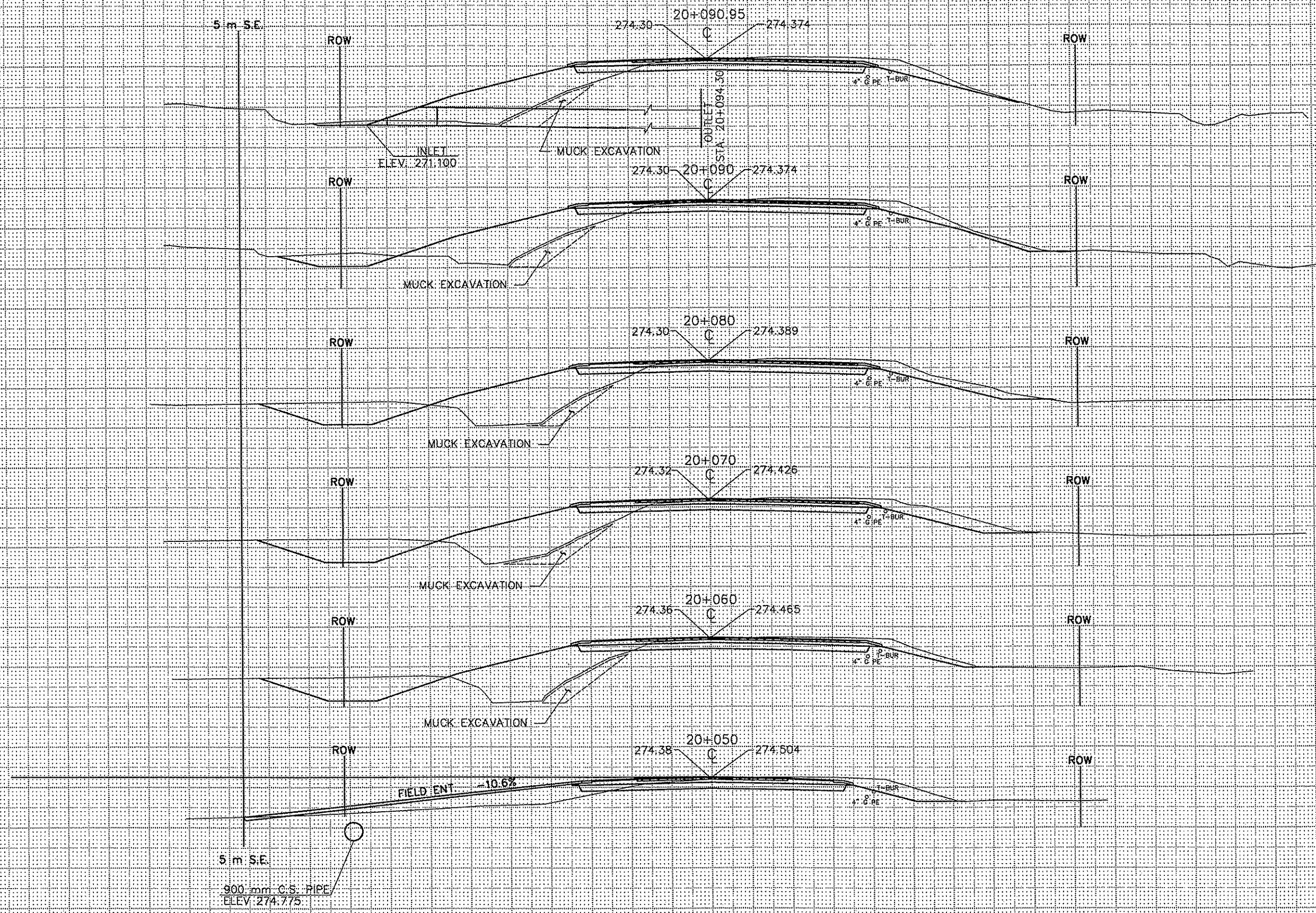

NO	DATE	BY	CKD	APPR	REVISION

NAME: X-Sec22.dwg 4-20-00 1:16:29 pm EST



I HEREBY CERTIFY THAT THIS PLAN WAS PREPARED BY ME OR UNDER MY DIRECT SUPERVISION AND THAT I AM A DULY REGISTERED PROFESSIONAL ENGINEER UNDER THE NAME OF THE STATE OF MINNESOTA.

Allyson

DATE 04/20/00 REG. NO. 25066

DRAWN BY: JMN DATE 12-22-99
 DESIGN BY: JMN DATE 12-22-99
 CHECKED BY: JLR DATE 12-22-99



ANOKA COUNTY
 HIGHWAY DEPT.

STATE PROJECT NO. _____
 STATE AID PROJECT NO. 02-622-27
 STATE AID PROJECT NO. 02-683-01
 COUNTY PROJECT NO. _____

CROSS-SECTION
 C.S.A.H 22
 STA. 20+050.000 TO 20+090.950
 Sheet 28 of 56 Sheets

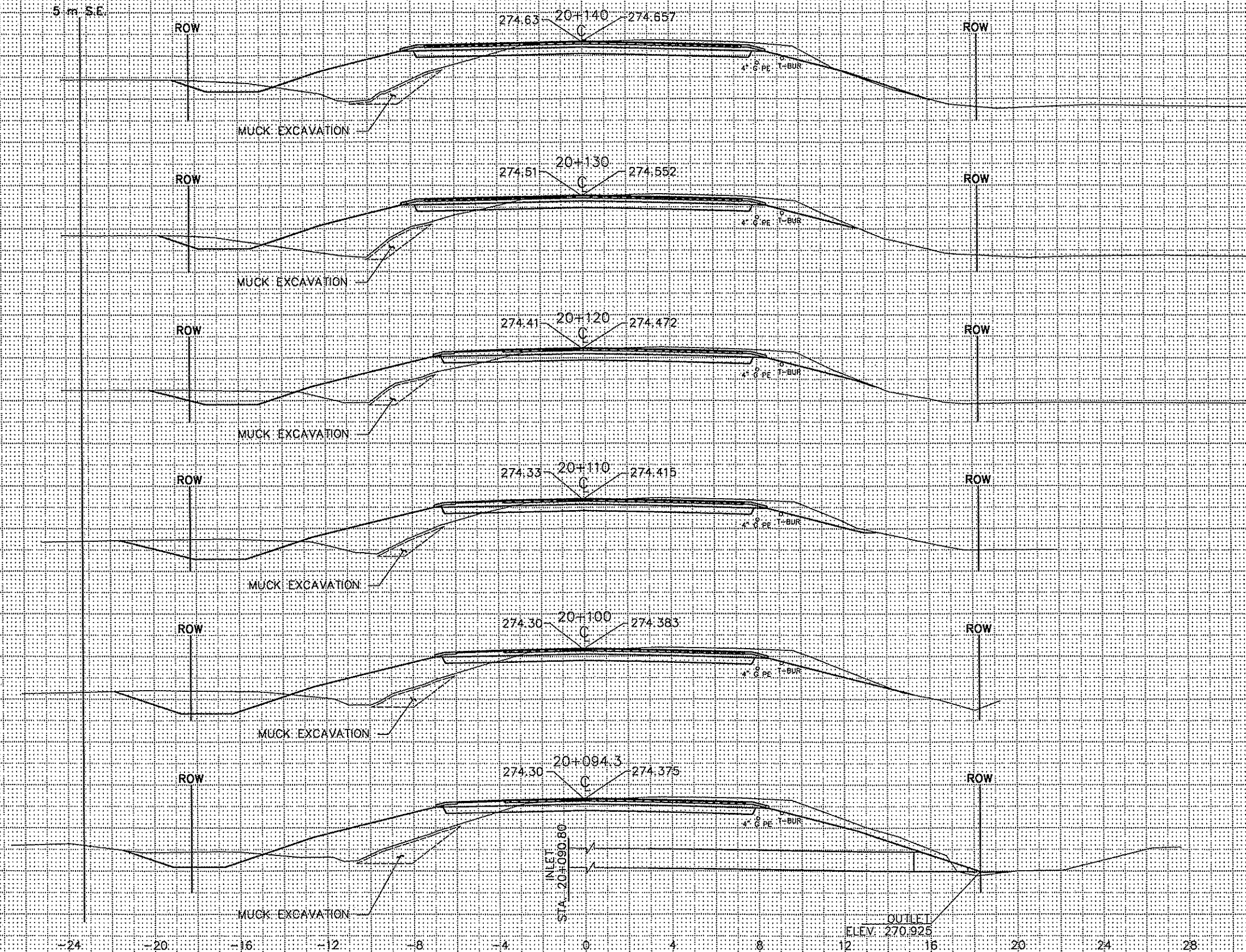

NO	DATE	BY	CKD	APPR	REVISION

NAME: X-Sec22.dwg 4-20-00 1:16:29 pm EST



I HEREBY CERTIFY THAT THIS PLAN WAS PREPARED BY ME OR UNDER MY DIRECT SUPERVISION AND THAT I AM A DULY REGISTERED PROFESSIONAL ENGINEER UNDER THE NAME OF THE STATE OF MINNESOTA.

Allyson

DATE 04/20/00 REG. NO. 25066

DRAWN BY: MN DATE 12-22-99
 DESIGN BY: MN DATE 12-22-99
 CHECKED BY: LR DATE 12-22-99

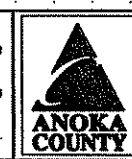

ANOKA COUNTY
 HIGHWAY DEPT.

STATE PROJECT NO. _____
 STATE AID PROJECT NO. 02-622-27
 STATE AID PROJECT NO. 02-683-01
 COUNTY PROJECT NO. _____

CROSS-SECTION
 C.S.A.H 22
 STA. 20+094.300 TO 20+140.000
 Sheet 29 of 56 Sheets

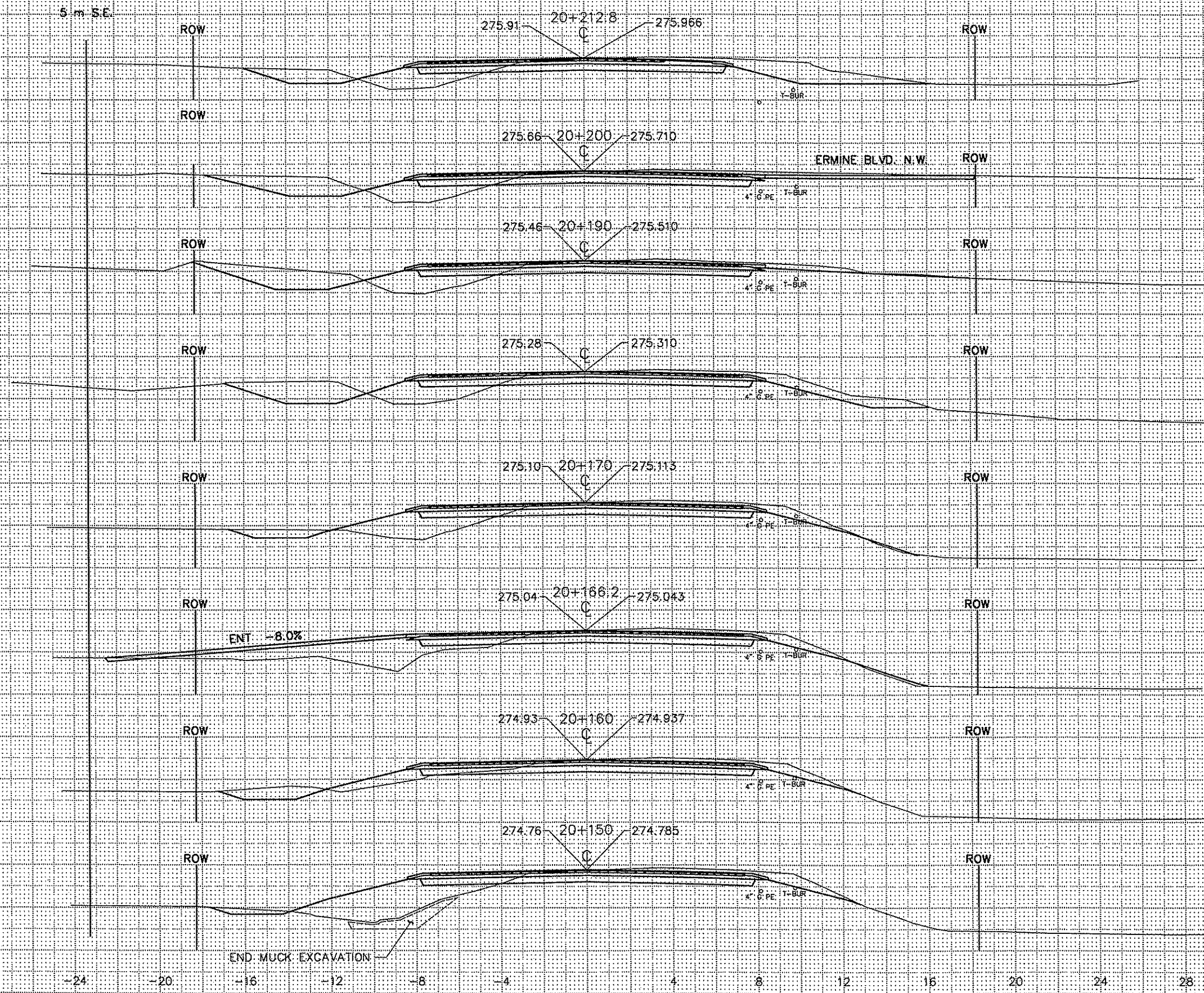

NO	DATE	BY	CKD	APPR	REVISION
NAME:	X-Sec22.dwg	4-20-00	1:16:29 pm	EST	



I HEREBY CERTIFY THAT THIS PLAN WAS PREPARED BY ME OR UNDER MY DIRECT SUPERVISION AND THAT I AM A DULY REGISTERED PROFESSIONAL ENGINEER UNDER THE LAWS OF THE STATE OF MINNESOTA.

Allyson

DATE 04/20/00 REG. NO. 25066

DRAWN BY: MN DATE 12-22-99
 DESIGN BY: MN DATE 12-22-99
 CHECKED BY: LR DATE 12-22-99



ANOKA COUNTY
 HIGHWAY DEPT.

STATE PROJECT NO. _____
 STATE AID PROJECT NO. 02-622-27
 STATE AID PROJECT NO. 02-683-01
 COUNTY PROJECT NO. _____

CROSS-SECTION
 C.S.A.H 22
 STA. 20+150.000 TO 20+212.800
 Sheet 30 of 56 Sheets

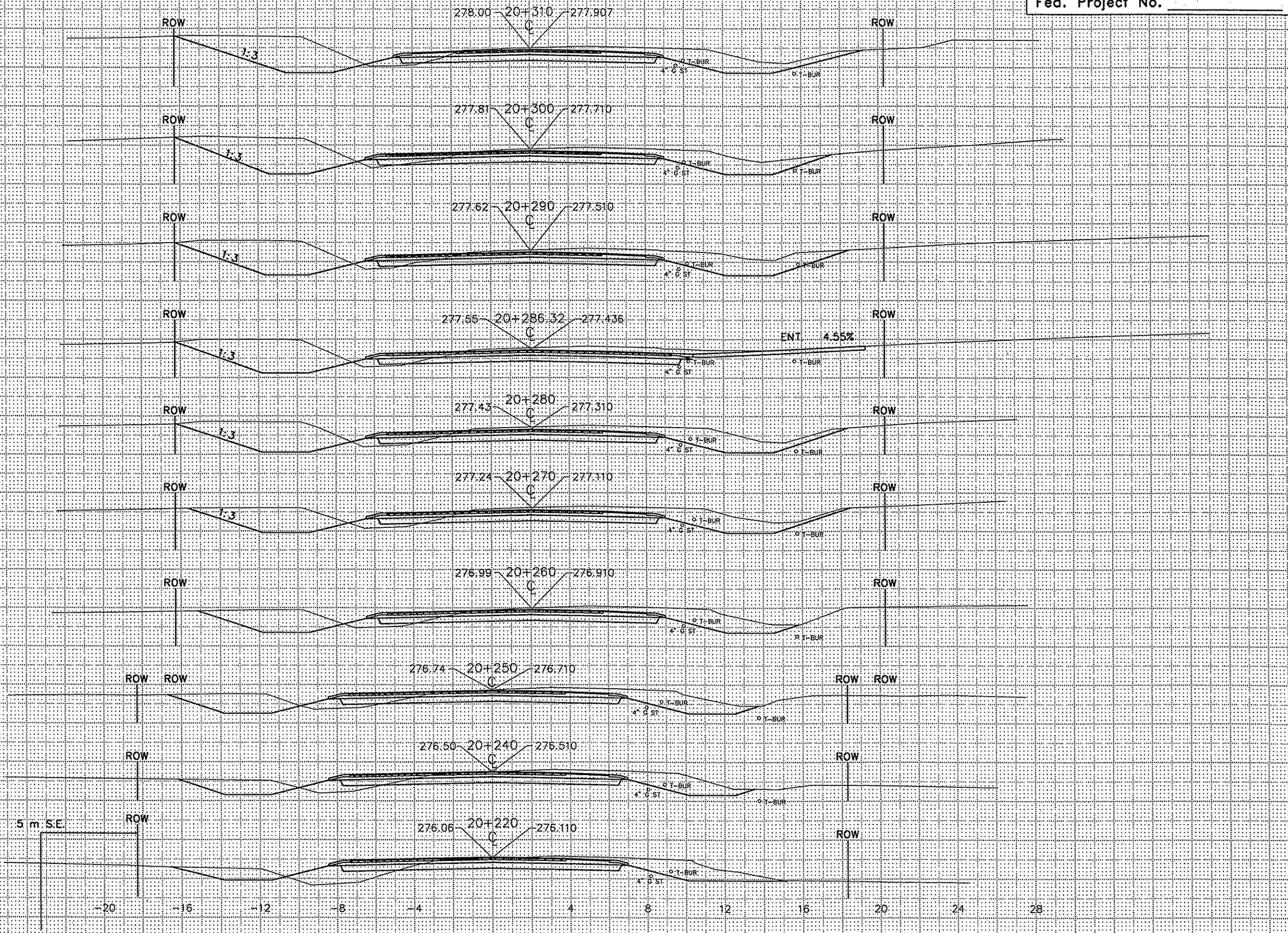

NO	DATE	BY	CKD	APPR	REVISION
1	4-20-00				

NAME: X-Sec22.dwg 4-20-00 1:16:29 pm EST



I HEREBY CERTIFY THAT THIS PLAN WAS PREPARED BY ME OR UNDER MY DIRECT SUPERVISION AND THAT I AM A DULY REGISTERED PROFESSIONAL ENGINEER UNDER THE LAWS OF THE STATE OF MINNESOTA.

Alberts

DATE 04/20/00 REG. NO. 25066

DRAWN BY: MN DATE 12-22-99
 DESIGN BY: MN DATE 12-22-99
 CHECKED BY: LR DATE 12-22-99



ANOKA COUNTY
 HIGHWAY DEPT.

STATE PROJECT NO. _____
 STATE AID PROJECT NO. 02-622-27
 STATE AID PROJECT NO. 02-683-01
 COUNTY PROJECT NO. _____

CROSS-SECTION
 C.S.A.H 22
 STA. 20+220.000 TO 20+310.000
 Sheet 31 of 56 Sheets

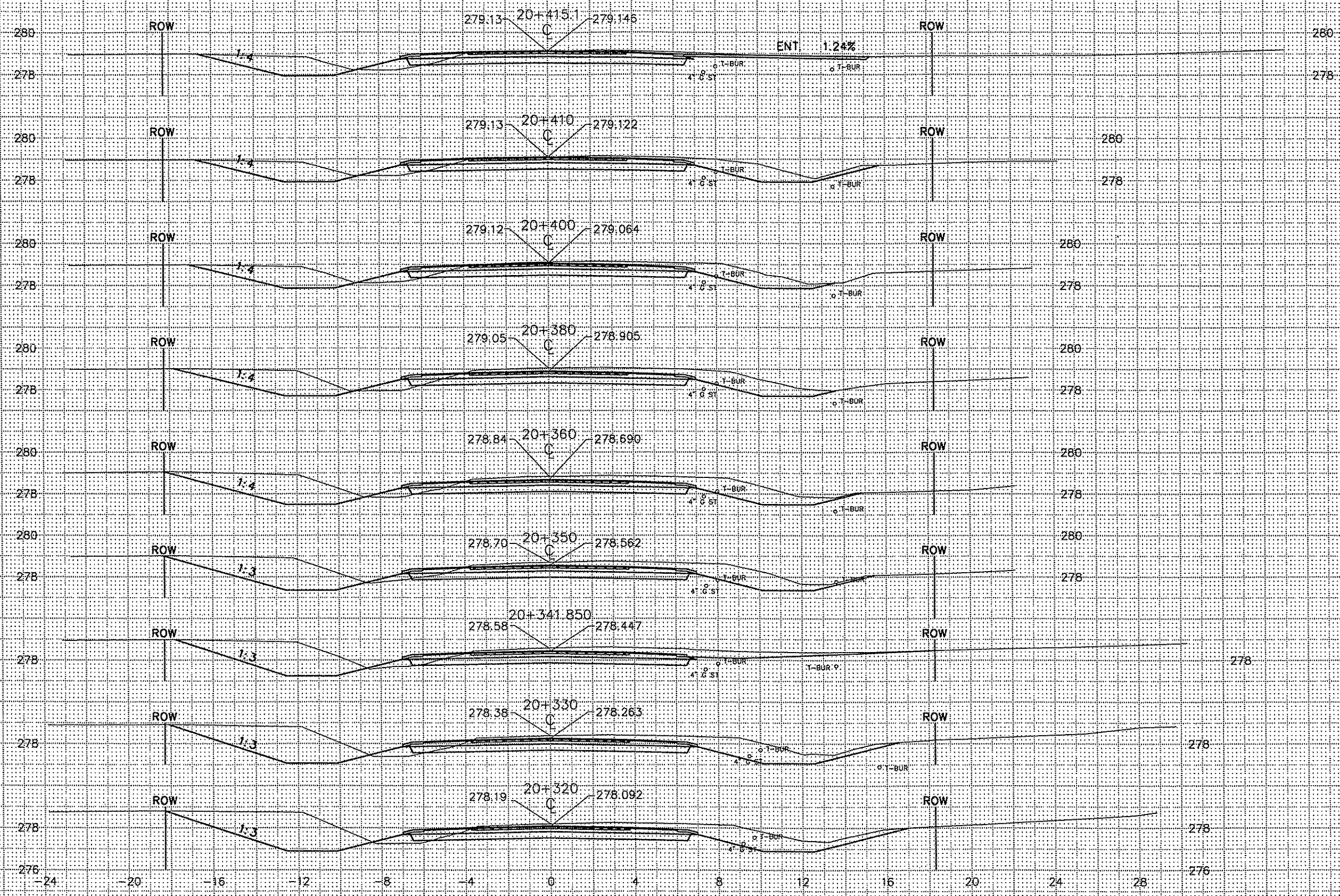

NO	DATE	BY	CKD	APPR	REVISION
NAME:	X-Sec22.dwg	4-20-00	1:16:29 pm	EST	



I HEREBY CERTIFY THAT THIS PLAN WAS PREPARED BY ME OR UNDER MY DIRECT SUPERVISION AND THAT I AM A DULY REGISTERED PROFESSIONAL ENGINEER UNDER THE LAWS OF THE STATE OF MINNESOTA.

Allyson

DATE 04/20/00 REG. NO. 25066

DRAWN BY: MN DATE 12-22-99
 DESIGN BY: MN DATE 12-22-99
 CHECKED BY: LR DATE 12-22-99



ANOKA COUNTY
HIGHWAY DEPT.

STATE PROJECT NO. _____
 STATE AID PROJECT NO. 02-622-27
 STATE AID PROJECT NO. 02-683-01
 COUNTY PROJECT NO. _____

CROSS-SECTION
C.S.A.H 22
 STA. 20+320.000 TO 20+415.100
 Sheet 32 of 56 Sheets

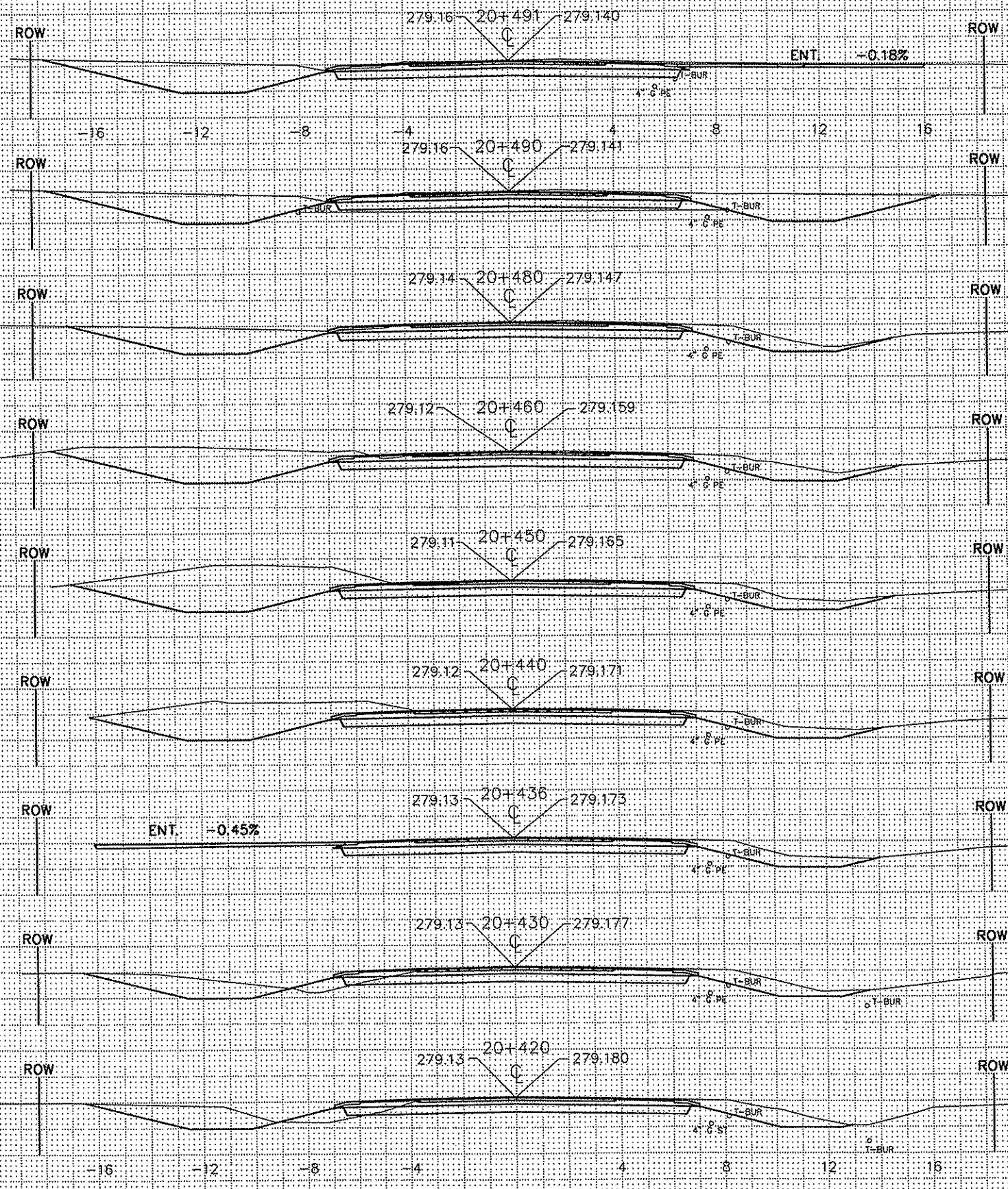

NO	DATE	BY	CKD	APPR	REVISION

NAME: X-Sec22.dwg 4-21-00 11:30:01 am EST



I HEREBY CERTIFY THAT THIS PLAN WAS PREPARED BY ME OR UNDER MY DIRECT SUPERVISION AND THAT I AM A DULY REGISTERED PROFESSIONAL ENGINEER UNDER THE NAME OF THE STATE OF MINNESOTA.

[Signature]

DATE 04/20/00 REG. NO. 25066

DRAWN BY: MN DATE 12-22-99
 DESIGN BY: MN DATE 12-22-99
 CHECKED BY: LR DATE 12-22-99



ANOKA COUNTY
 HIGHWAY DEPT.

STATE PROJECT NO. _____
 STATE AID PROJECT NO. 02-622-27
 STATE AID PROJECT NO. 02-683-01
 COUNTY PROJECT NO. _____

CROSS-SECTION
 C.S.A.H 22
 STA. 20+420.000 TO 20+491.000
 Sheet 33 of 56 Sheets

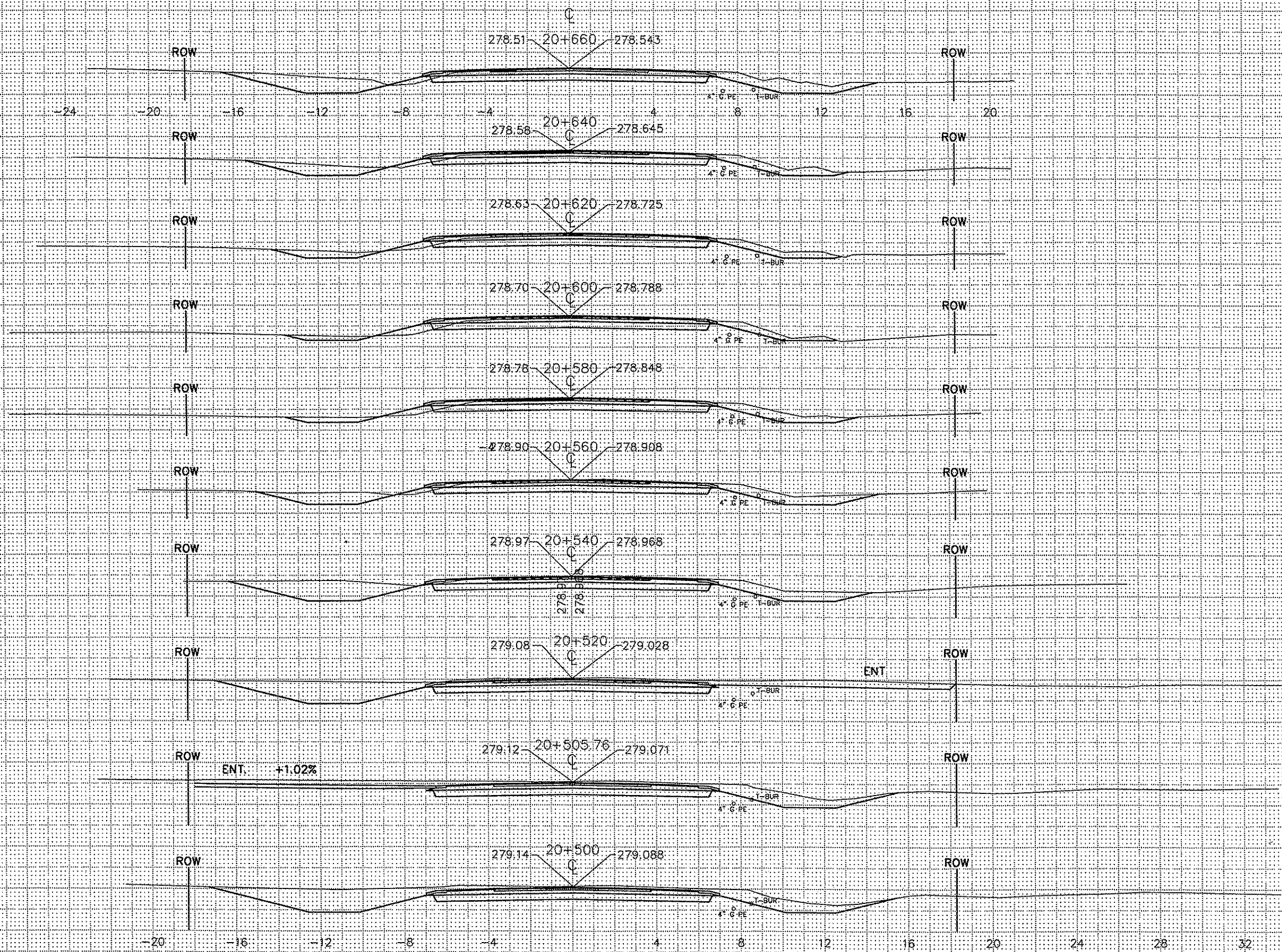

NO	DATE	BY	CKD	APPR	REVISION
1	4-21-00				
NAME: X-Sec22.dwg 4-21-00 11:30:01 am EST					



I HEREBY CERTIFY THAT THIS PLAN WAS PREPARED BY ME OR UNDER MY DIRECT SUPERVISION AND THAT I AM A DULY REGISTERED PROFESSIONAL ENGINEER UNDER THE LAWS OF THE STATE OF MINNESOTA.

Albert S.
 DATE 04/20/00 REG. NO. 25066

DRAWN BY: MN DATE 12-22-99
 DESIGN BY: MN DATE 12-22-99
 CHECKED BY: LR DATE 12-22-99



ANOKA COUNTY
 HIGHWAY DEPT.

STATE PROJECT NO. _____
 STATE AID PROJECT NO. 02-622-27
 STATE AID PROJECT NO. 02-683-01
 COUNTY PROJECT NO. _____

CROSS-SECTION
 C.S.A.H 22
 STA. 20+500.000 TO 20+690.000
 Sheet 34 of 56 Sheets

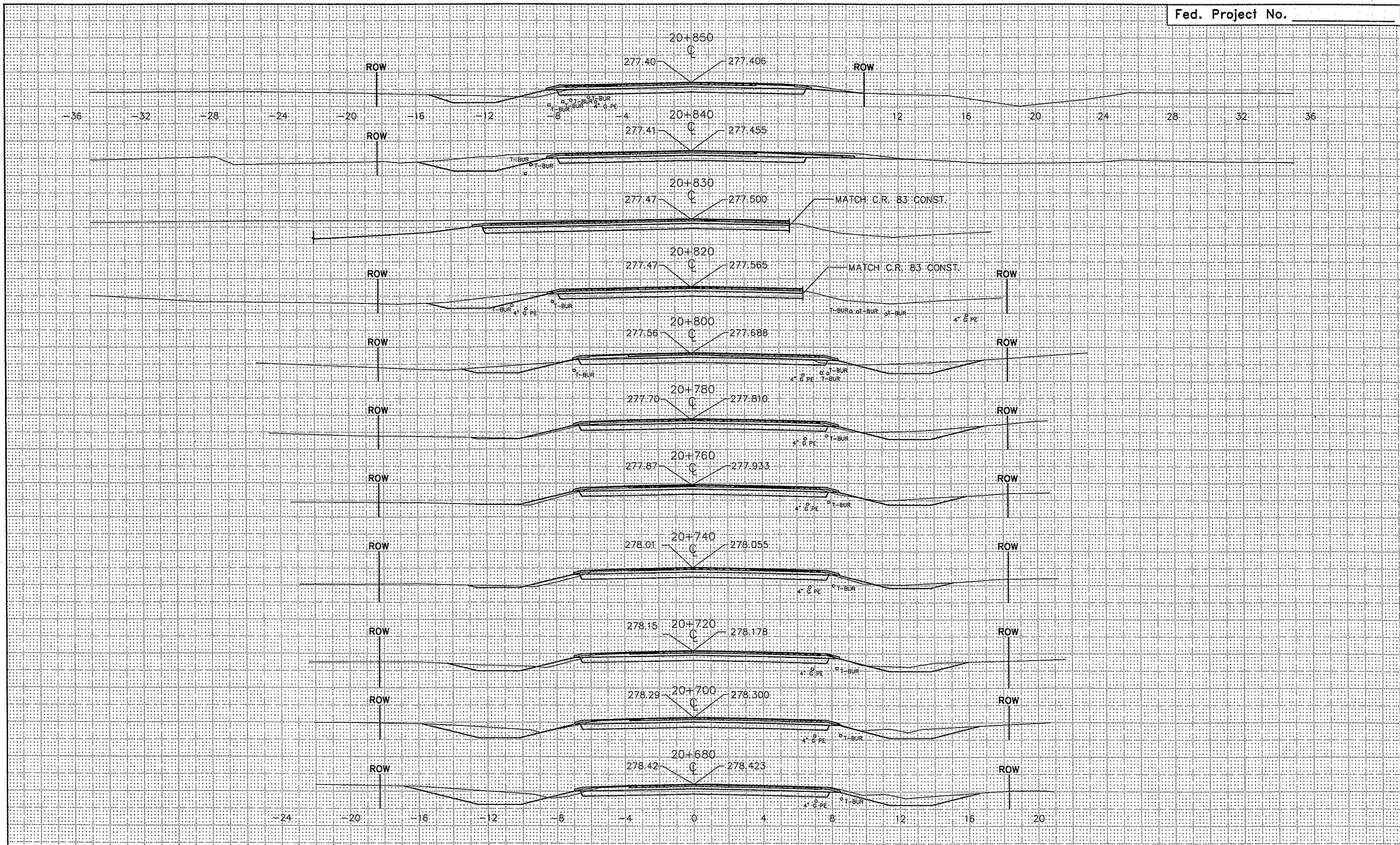

I HEREBY CERTIFY THAT THIS PLAN WAS PREPARED BY ME OR UNDER MY DIRECT SUPERVISION AND THAT I AM A DULY REGISTERED PROFESSIONAL ENGINEER UNDER THE LAWS OF THE STATE OF MINNESOTA.

Allyson

DATE 04/20/00 REG. NO. 25066

DRAWN BY: MN DATE 12-22-99
 DESIGN BY: MN DATE 12-22-99
 CHECKED BY: LR DATE 12-22-99



ANOKA COUNTY
 HIGHWAY DEPT.

STATE PROJECT NO. _____
 STATE AID PROJECT NO. 02-622-27
 STATE AID PROJECT NO. 02-683-01
 COUNTY PROJECT NO. _____

CROSS-SECTION
 C.S.A.H 22
 STA. 20+700.000 TO 20+850.000
 Sheet 35 of 56 Sheets

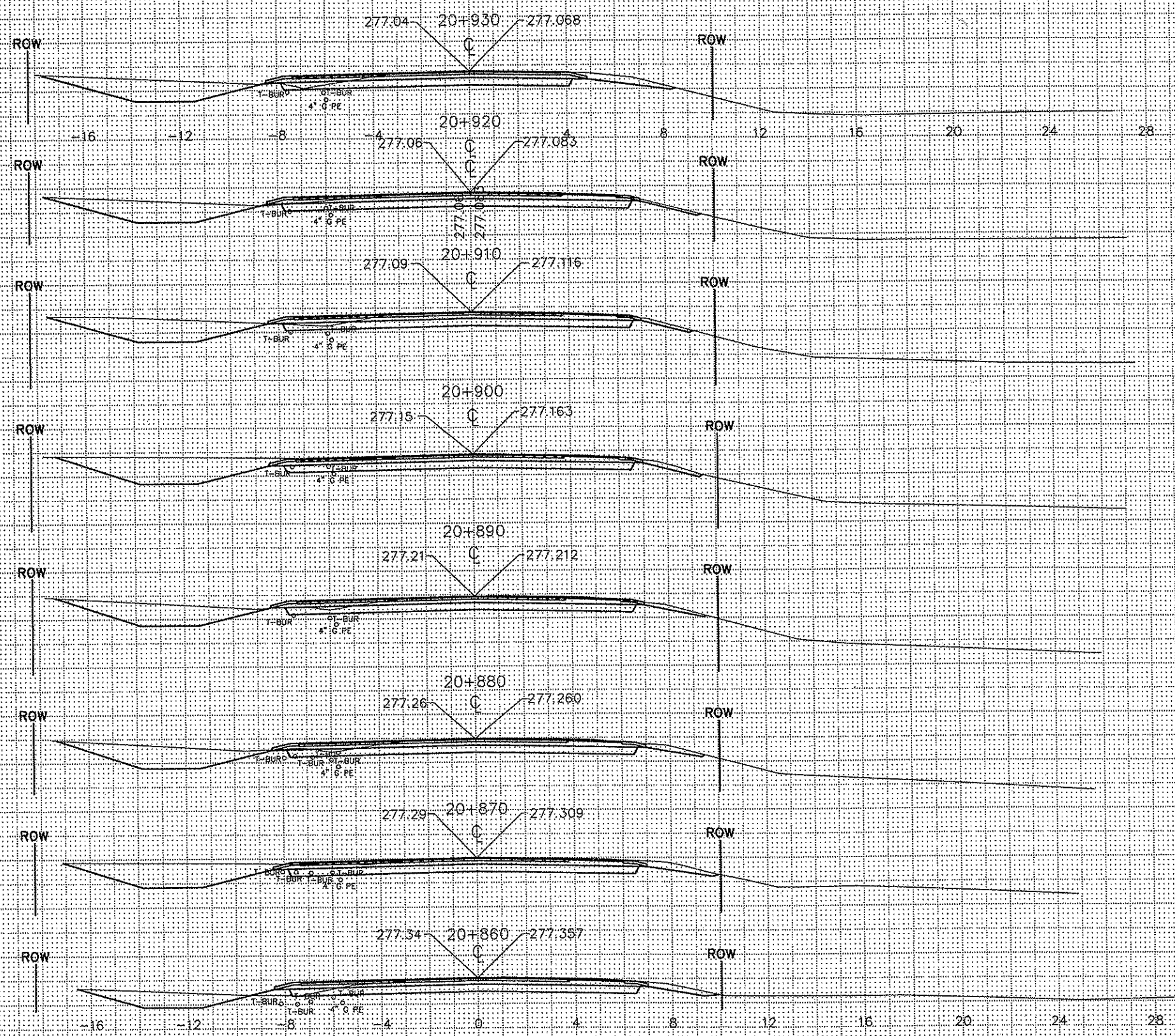

NO	DATE	BY	CKD	APPR	REVISION

NAME: X-Sec22.dwg 4-21-00 11:30:01 am EST



I HEREBY CERTIFY THAT THIS PLAN WAS PREPARED BY ME OR UNDER MY DIRECT SUPERVISION AND THAT I AM A DULY REGISTERED PROFESSIONAL ENGINEER UNDER THE LAWS OF THE STATE OF MINNESOTA.

Albert

DATE 04/20/00 REG. NO. 25066

DRAWN BY: MN DATE 12-22-99
 DESIGN BY: MN DATE 12-22-99
 CHECKED BY: LR DATE 12-22-99



ANOKA COUNTY
 HIGHWAY DEPT.

STATE PROJECT NO. _____
 STATE AID PROJECT NO. 02-622-27
 STATE AID PROJECT NO. 02-683-01
 COUNTY PROJECT NO. _____

CROSS-SECTION
 C.S.A.H 22
 STA. 20+860.000 TO 20+930.000
 Sheet 36 of 56 Sheets

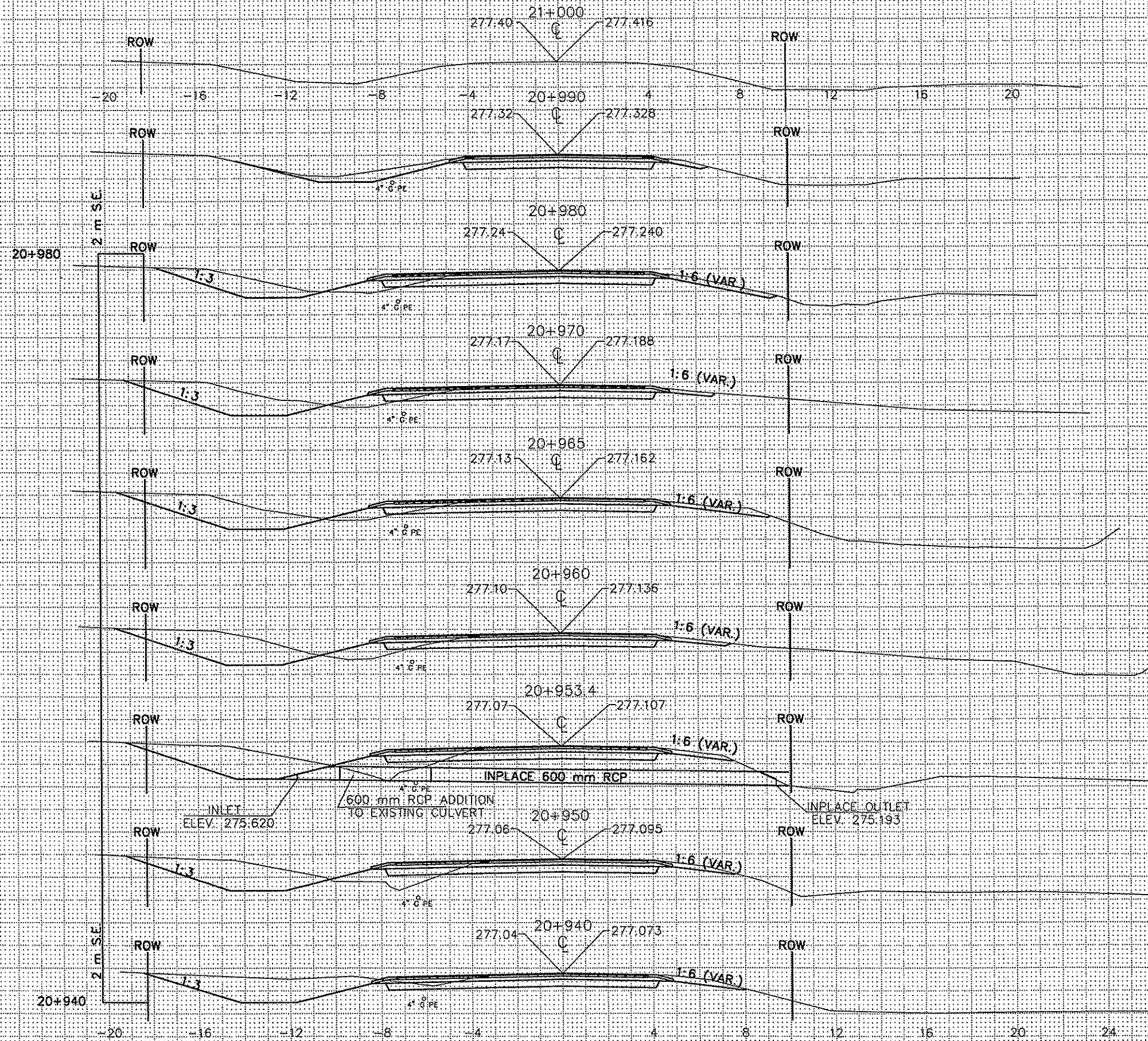

NO	DATE	BY	CKD	APPR	REVISION
1	4-21-00				
2	11-30-01				am EST



I HEREBY CERTIFY THAT THIS PLAN WAS PREPARED BY ME OR UNDER MY DIRECT SUPERVISION AND THAT I AM A DULY REGISTERED PROFESSIONAL ENGINEER UNDER THE LAWS OF THE STATE OF MINNESOTA.

Albert

DATE 04/20/00 REG. NO. 25066

DRAWN BY: JN DATE 12-22-99
 DESIGN BY: JN DATE 12-22-99
 CHECKED BY: JR DATE 12-22-99



ANOKA COUNTY
 HIGHWAY DEPT.

STATE PROJECT NO. _____
 STATE AID PROJECT NO. 02-622-27
 STATE AID PROJECT NO. 02-683-01
 COUNTY PROJECT NO. _____

CROSS-SECTION
 C.S.A.H 22
 STA. 20+940.000 TO 21+000.000
 Sheet 37 of 56 Sheets

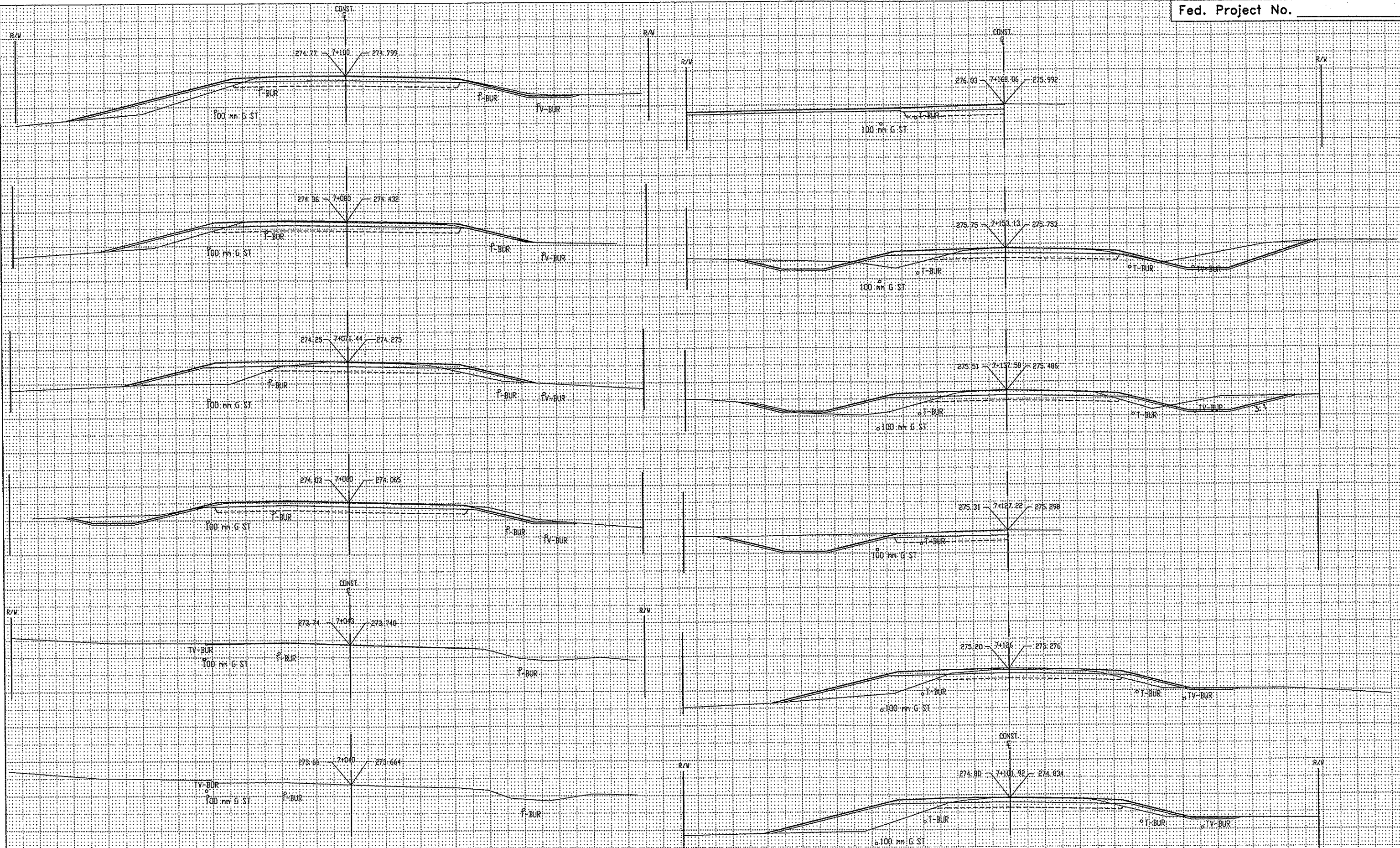

NO	DATE	BY	CKD	APPR	REVISION

NAME: 83XSEC-01.dwg 4-21-00 1:54:07 pm EST



I HEREBY CERTIFY THAT THIS PLAN WAS PREPARED BY ME OR UNDER MY DIRECT SUPERVISION AND THAT I AM A DULY REGISTERED PROFESSIONAL ENGINEER UNDER THE LAWS OF THE STATE OF MINNESOTA.

[Signature]

DATE 04-20-00 REG. NO. 25066

DRAWN BY: MN DATE 04/20/00
 DESIGN BY: KGJ DATE 04/20/00
 CHECKED BY: LAR DATE 04/20/00

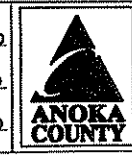

ANOKA COUNTY
 HIGHWAY DEPT.

STATE PROJECT NO. _____
 STATE AID PROJECT NO. 02-622-27
 STATE AID PROJECT NO. 02-683-01
 COUNTY PROJECT NO. _____

CROSS-SECTION
 C.S.A.H. 83
 STA 7+040.000 TO 7+168.060
 Sheet 38 of 56 Sheets

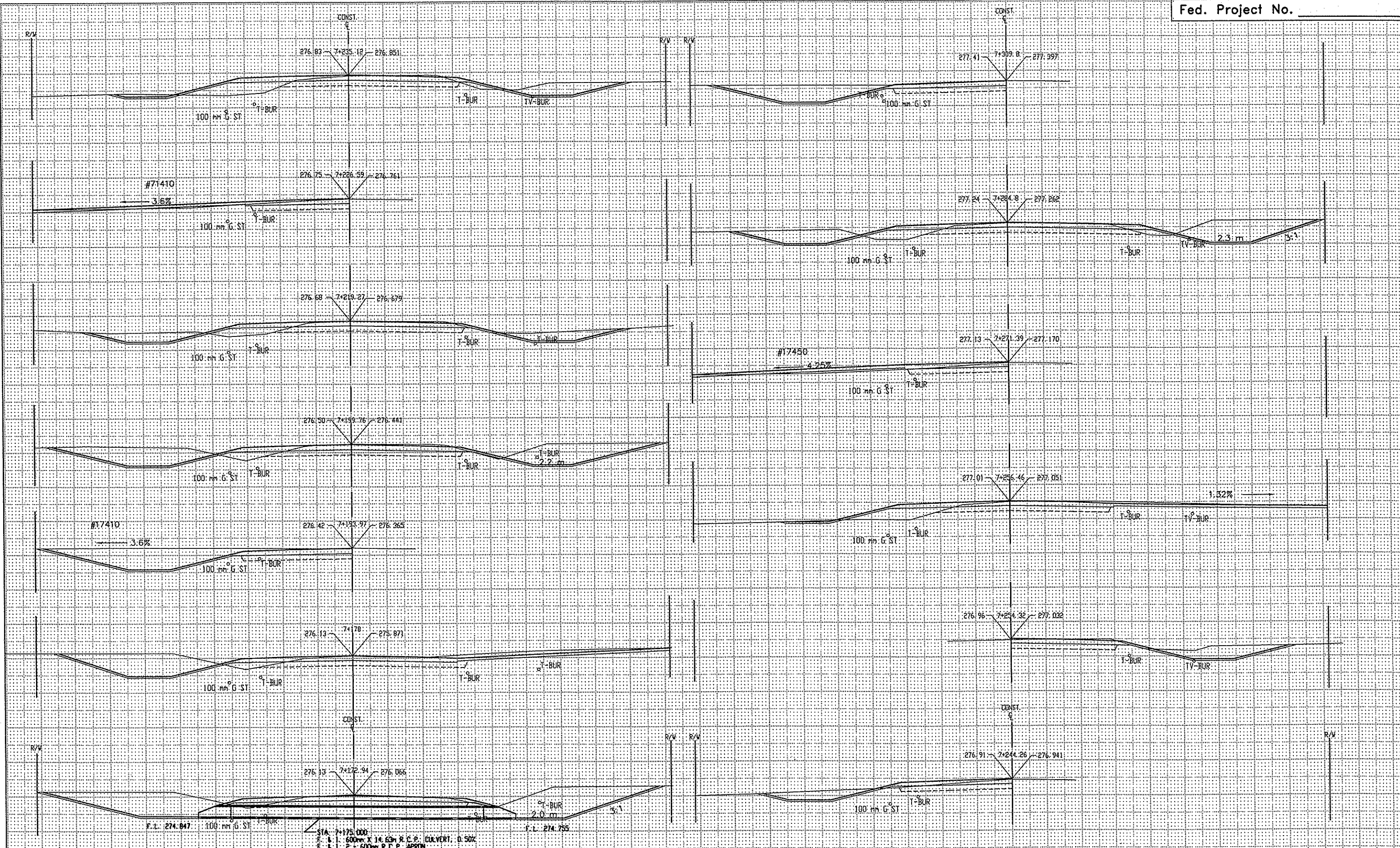

NO	DATE	BY	CKD	APPR	REVISION



I HEREBY CERTIFY THAT THIS PLAN WAS PREPARED BY ME OR UNDER MY DIRECT SUPERVISION AND THAT I AM A DULY REGISTERED PROFESSIONAL ENGINEER UNDER THE LAWS OF THE STATE OF MINNESOTA.

Allyson

DATE 04-20-00 REG. NO. 25066

DRAWN BY: MN DATE 04/20/00
 DESIGN BY: KGJ DATE 04/20/00
 CHECKED BY: LAR DATE 04/20/00

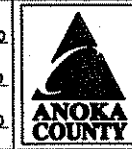

ANOKA COUNTY HIGHWAY DEPT.

STATE PROJECT NO. _____
 STATE AID PROJECT NO. 02-622-27
 STATE AID PROJECT NO. 02-683-01
 COUNTY PROJECT NO. _____

CROSS-SECTION C.S.A.H. 83
 STA 7+172+940 TO 7+309.800
 Sheet 39 of 56 Sheets

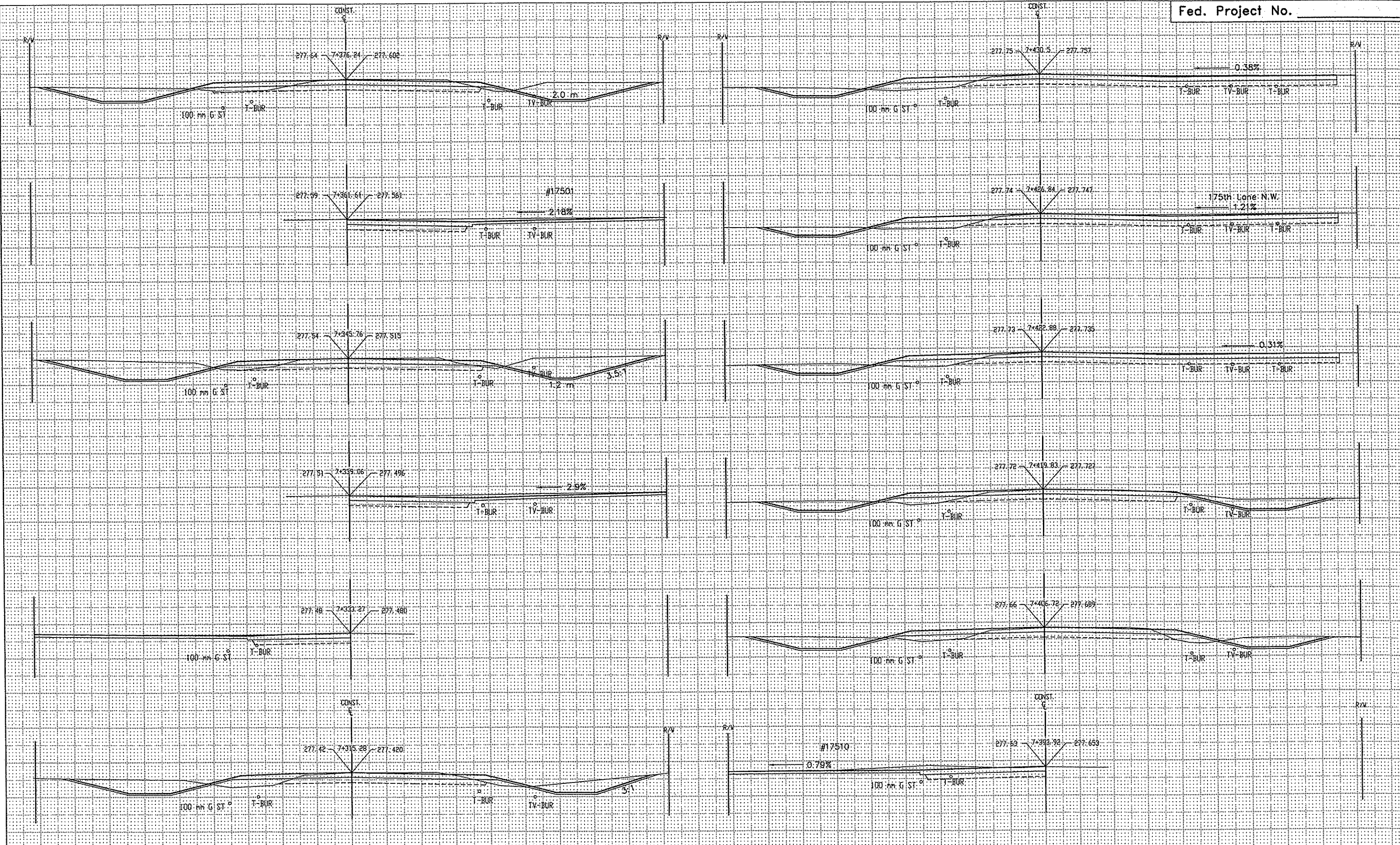

NO	DATE	BY	CKD	APPR	REVISION



I HEREBY CERTIFY THAT THIS PLAN WAS PREPARED BY ME OR UNDER MY DIRECT SUPERVISION AND THAT I AM A DULY REGISTERED PROFESSIONAL ENGINEER UNDER THE LAWS OF THE STATE OF MINNESOTA.

Allyson

DATE 04-20-00 REG. NO. 25066

DRAWN BY: MN DATE 04/20/00
 DESIGN BY: KGJ DATE 04/20/00
 CHECKED BY: LAR DATE 04/20/00

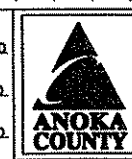

ANOKA COUNTY
 HIGHWAY DEPT.

STATE PROJECT NO. _____
 STATE AID PROJECT NO. 02-622-27
 STATE AID PROJECT NO. 02-683-01
 COUNTY PROJECT NO. _____

CROSS-SECTION
 C.S.A.H. 83
 STA 7+315+280 TO 7+430.500
 Sheet 40 of 56 Sheets

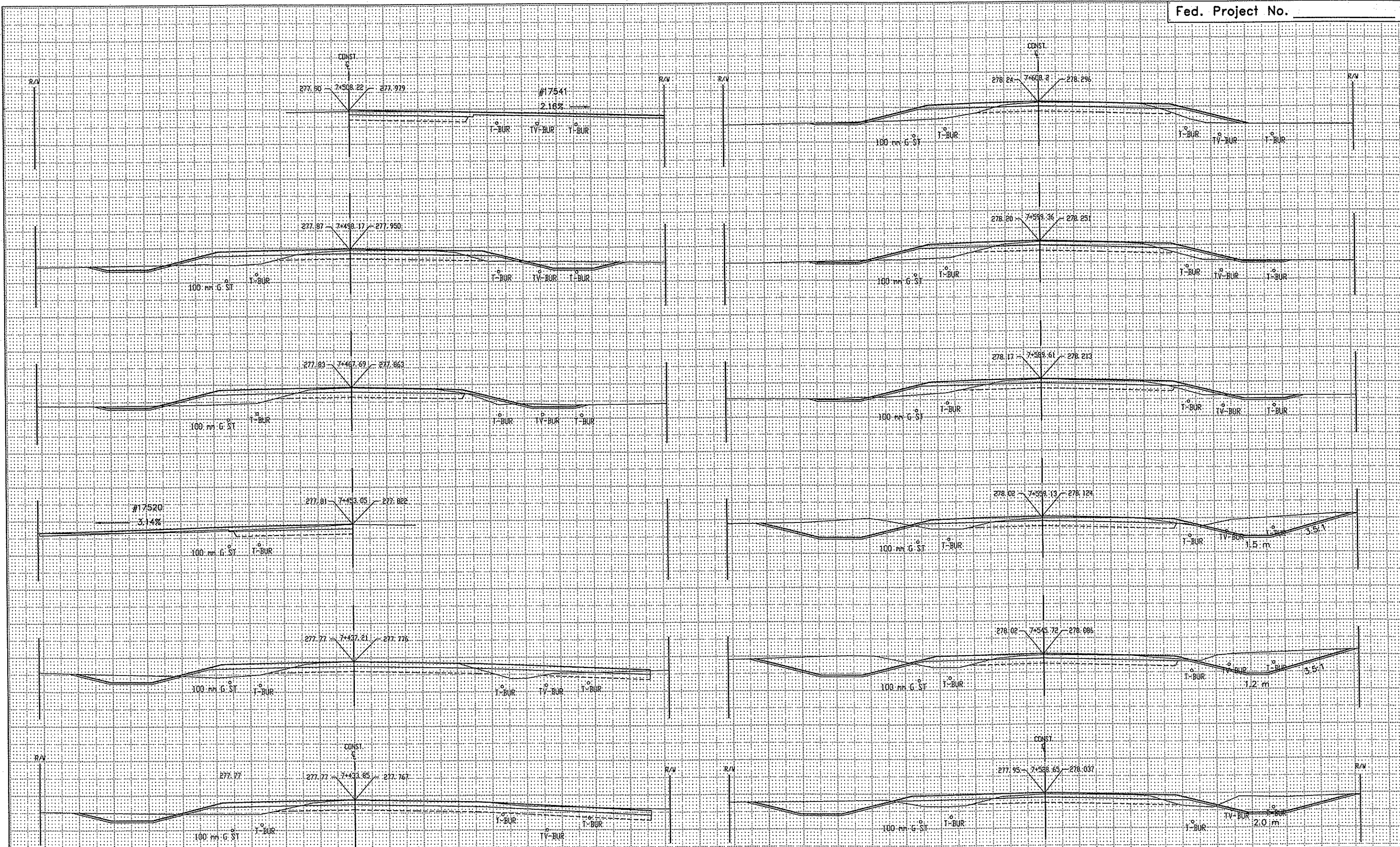

NO	DATE	BY	CKD	APPR	REVISION

NAME: B3XSEC-04.dwg 4-21-00 2:01:00 pm EST



I HEREBY CERTIFY THAT THIS PLAN WAS PREPARED BY ME OR UNDER MY DIRECT SUPERVISION AND THAT I AM A DULY REGISTERED PROFESSIONAL ENGINEER UNDER THE LAWS OF THE STATE OF MINNESOTA.

Signature

DATE 04-20-00 REG. NO. 25066

DRAWN BY: MN DATE 04/20/00
 DESIGN BY: KGJ DATE 04/20/00
 CHECKED BY: LAR DATE 04/20/00

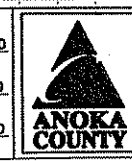

ANOKA COUNTY
 HIGHWAY DEPT.

STATE PROJECT NO. _____
 STATE AID PROJECT NO. 02-622-27
 STATE AID PROJECT NO. 02-683-01
 COUNTY PROJECT NO. _____

CROSS-SECTION
 C.S.A.H. 83
 STA 7+433.85 TO 7+608.200
 Sheet 41 of 56 Sheets

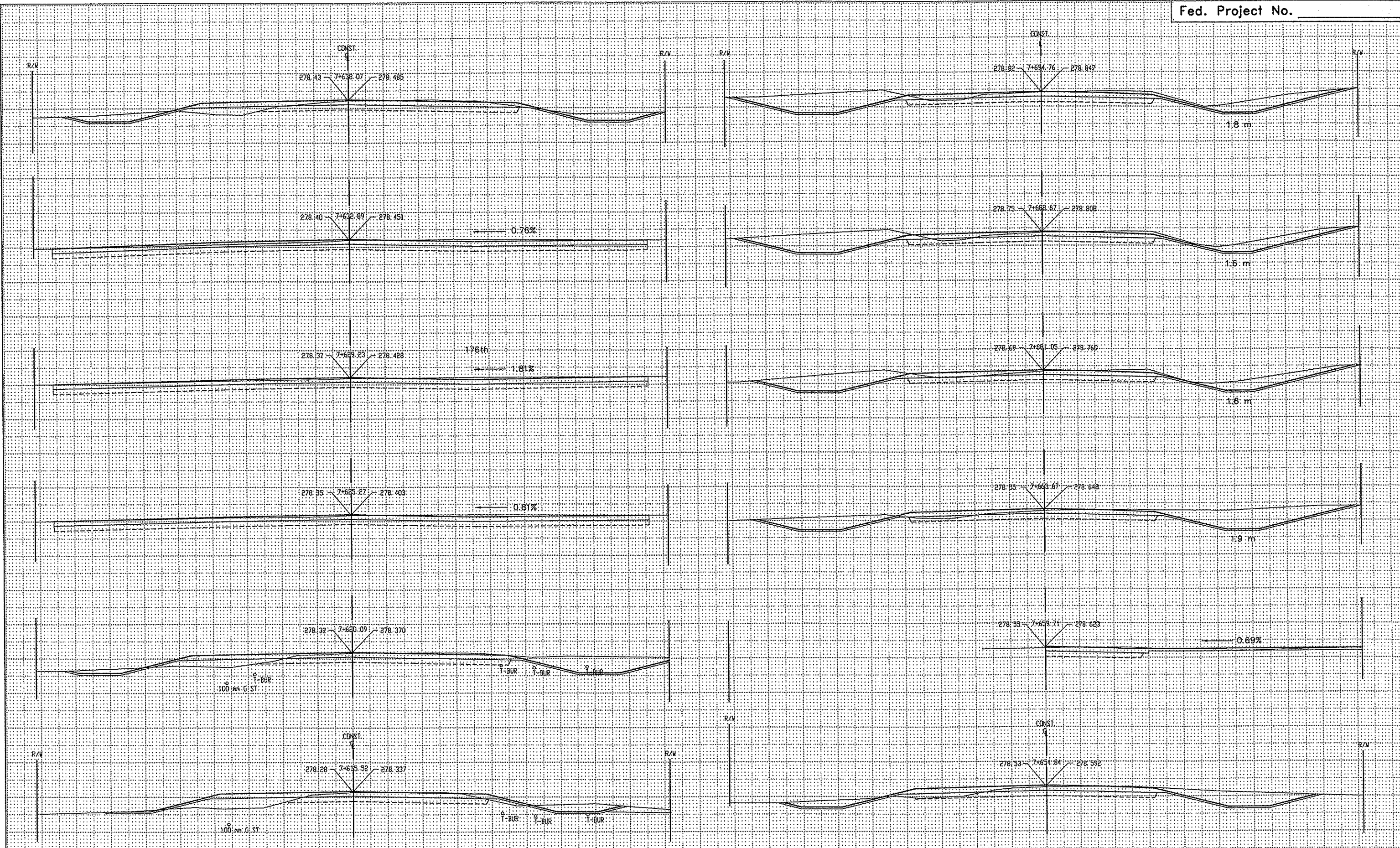

NO	DATE	BY	CKD	APPR	REVISION



I HEREBY CERTIFY THAT THIS PLAN WAS PREPARED BY ME OR UNDER MY DIRECT SUPERVISION AND THAT I AM A DULY REGISTERED PROFESSIONAL ENGINEER UNDER THE LAWS OF THE STATE OF MINNESOTA.

[Signature]

DATE 04-20-00 REG. NO. 25066

DRAWN BY: MN DATE 04/20/00
 DESIGN BY: KGJ DATE 04/20/00
 CHECKED BY: LAR DATE 04/20/00

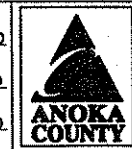

ANOKA COUNTY
 HIGHWAY DEPT.

STATE PROJECT NO. _____
 STATE AID PROJECT NO. 02-622-27
 STATE AID PROJECT NO. 02-683-01
 COUNTY PROJECT NO. _____

CROSS-SECTION
 C.S.A.H. 83
 STA 7+615.520 TO 7+694.760
 Sheet 42 of 56 Sheets

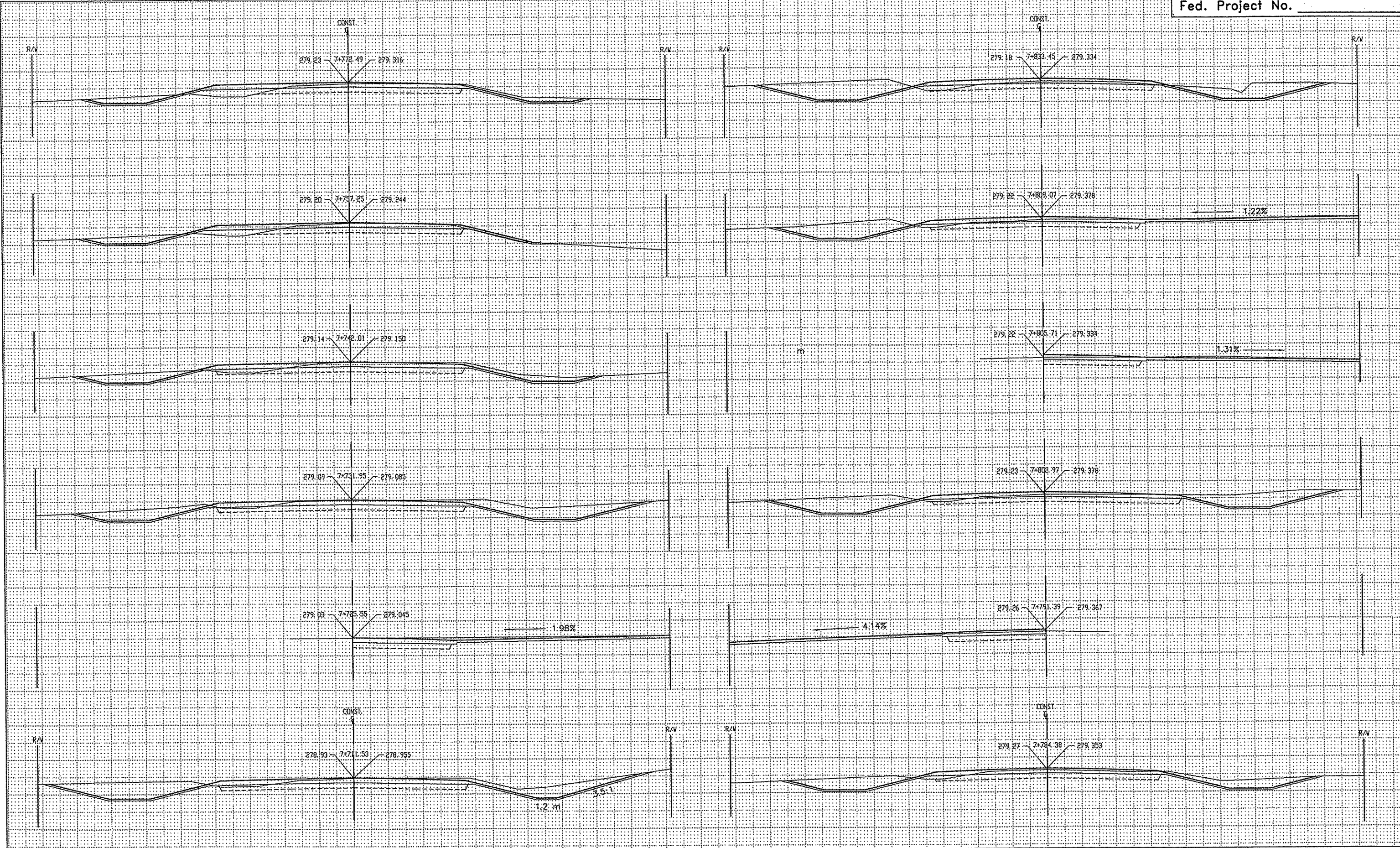

NO	DATE	BY	CKD	APPR	REVISION

NAME: 83XSEC-06.dwg 4-21-00 2:0742 pm EST



I HEREBY CERTIFY THAT THIS PLAN WAS PREPARED BY ME OR UNDER MY DIRECT SUPERVISION AND THAT I AM A DULY REGISTERED PROFESSIONAL ENGINEER UNDER THE LAWS OF THE STATE OF MINNESOTA.

Allyson

DATE 04-20-00 REG. NO. 25066

DRAWN BY: MN DATE 04/20/00
 DESIGN BY: KGJ DATE 04/20/00
 CHECKED BY: LAR DATE 04/20/00



ANOKA COUNTY
 HIGHWAY DEPT.

STATE PROJECT NO. _____
 STATE AID PROJECT NO. 02-622-27
 STATE AID PROJECT NO. 02-683-01
 COUNTY PROJECT NO. _____

CROSS-SECTION
 STA 7+711.530 TO 7+833.450
 Sheet 43 of 56 Sheets

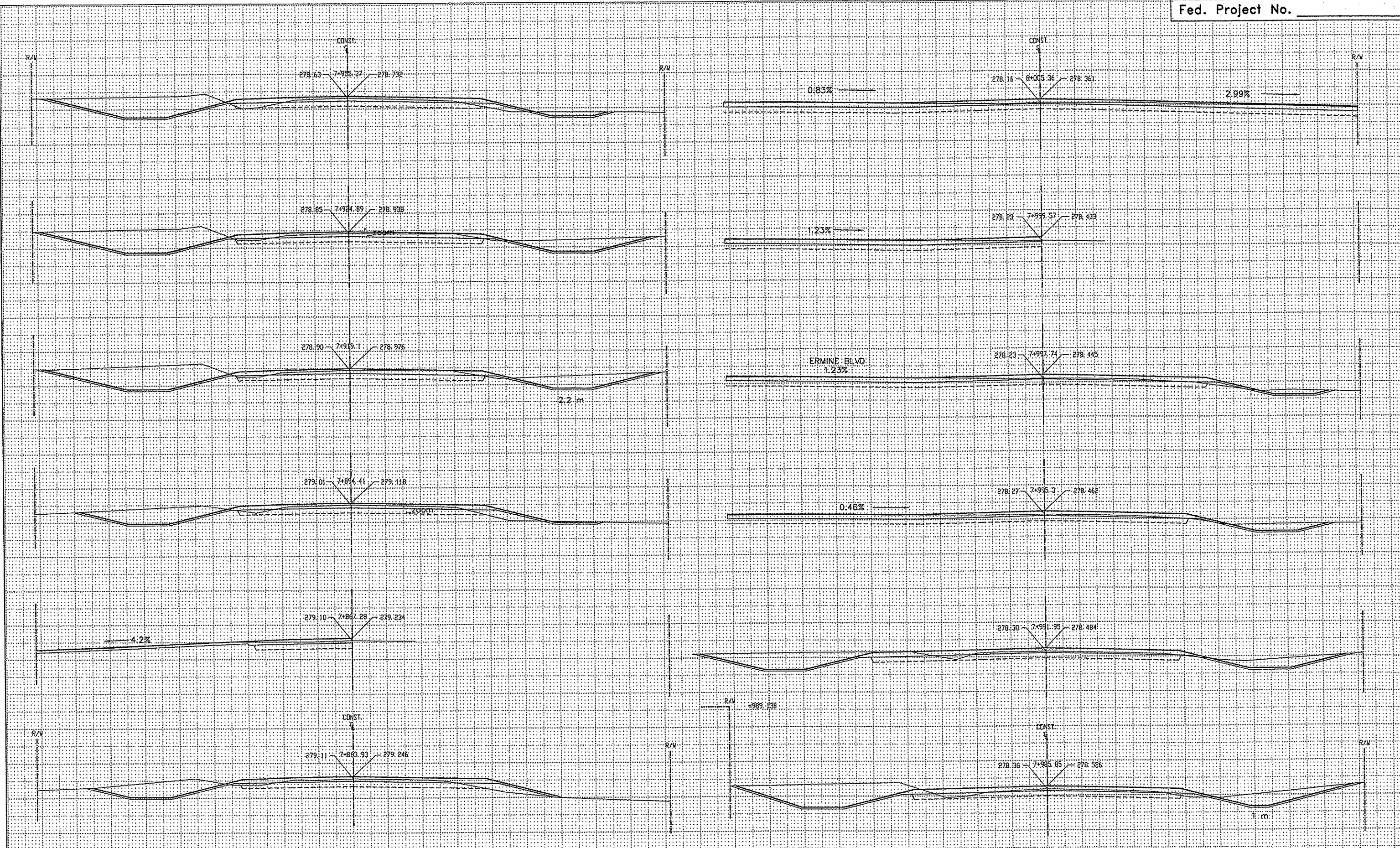

NO	DATE	BY	CKD	APPR	REVISION

NAME: B3XSEC-07.dwg 4-21-00 2:09:46 pm EST



I HEREBY CERTIFY THAT THIS PLAN WAS PREPARED BY ME OR UNDER MY DIRECT SUPERVISION AND THAT I AM A DULY REGISTERED PROFESSIONAL ENGINEER UNDER THE LAWS OF THE STATE OF MINNESOTA.

[Signature]

DATE 04-20-00 REG. NO. 25066

DRAWN BY: MN DATE 04/20/00
 DESIGN BY: KGJ DATE 04/20/00
 CHECKED BY: LAR DATE 04/20/00

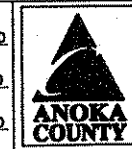

ANOKA COUNTY
 HIGHWAY DEPT.

STATE PROJECT NO. _____
 STATE AID PROJECT NO. 02-622-27
 STATE AID PROJECT NO. 02-683-01
 COUNTY PROJECT NO. _____

CROSS-SECTION
 STA 7+863.930 TO 8+005.360
 Sheet 44 of 56 Sheets

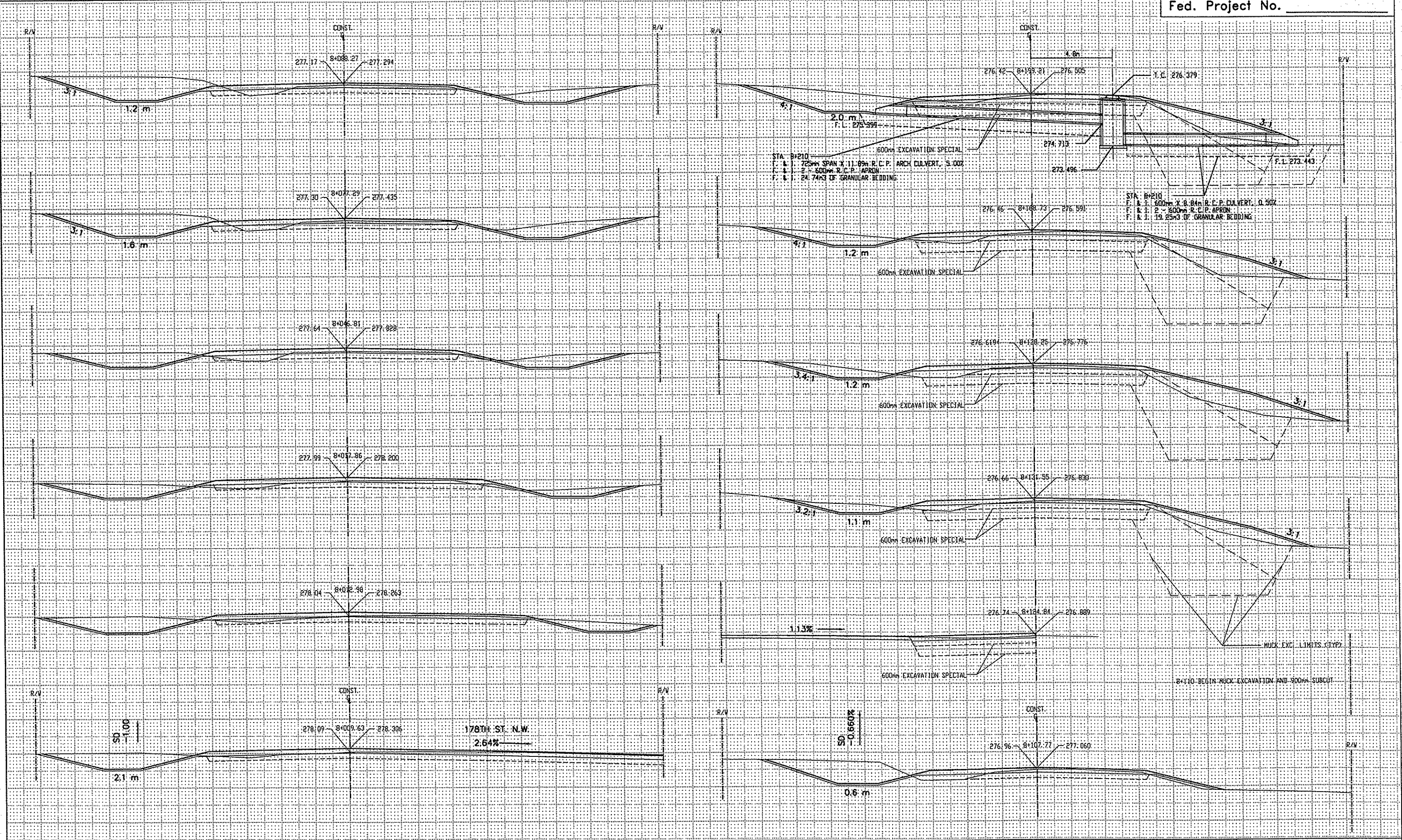

NO	DATE	BY	CKD	APPR	REVISION

NAME: 83XSEC-08.dwg 4-21-00 10:04:43 am EST



I HEREBY CERTIFY THAT THIS PLAN WAS PREPARED BY ME OR UNDER MY DIRECT SUPERVISION AND THAT I AM A DULY REGISTERED PROFESSIONAL ENGINEER UNDER THE LAWS OF THE STATE OF MINNESOTA.

Signature

DATE 04-20-00 REG. NO. 25066

DRAWN BY: MN DATE 04/20/00
 DESIGN BY: KGJ DATE 04/20/00
 CHECKED BY: LAR DATE 04/20/00



ANOKA COUNTY
 HIGHWAY DEPT.

STATE PROJECT NO. _____
 STATE AID PROJECT NO. 02-622-27
 STATE AID PROJECT NO. 02-683-01
 COUNTY PROJECT NO. _____

CROSS-SECTION
 STA 8+09.630 TO 8+199.210
 Sheet 45 of 56 Sheets

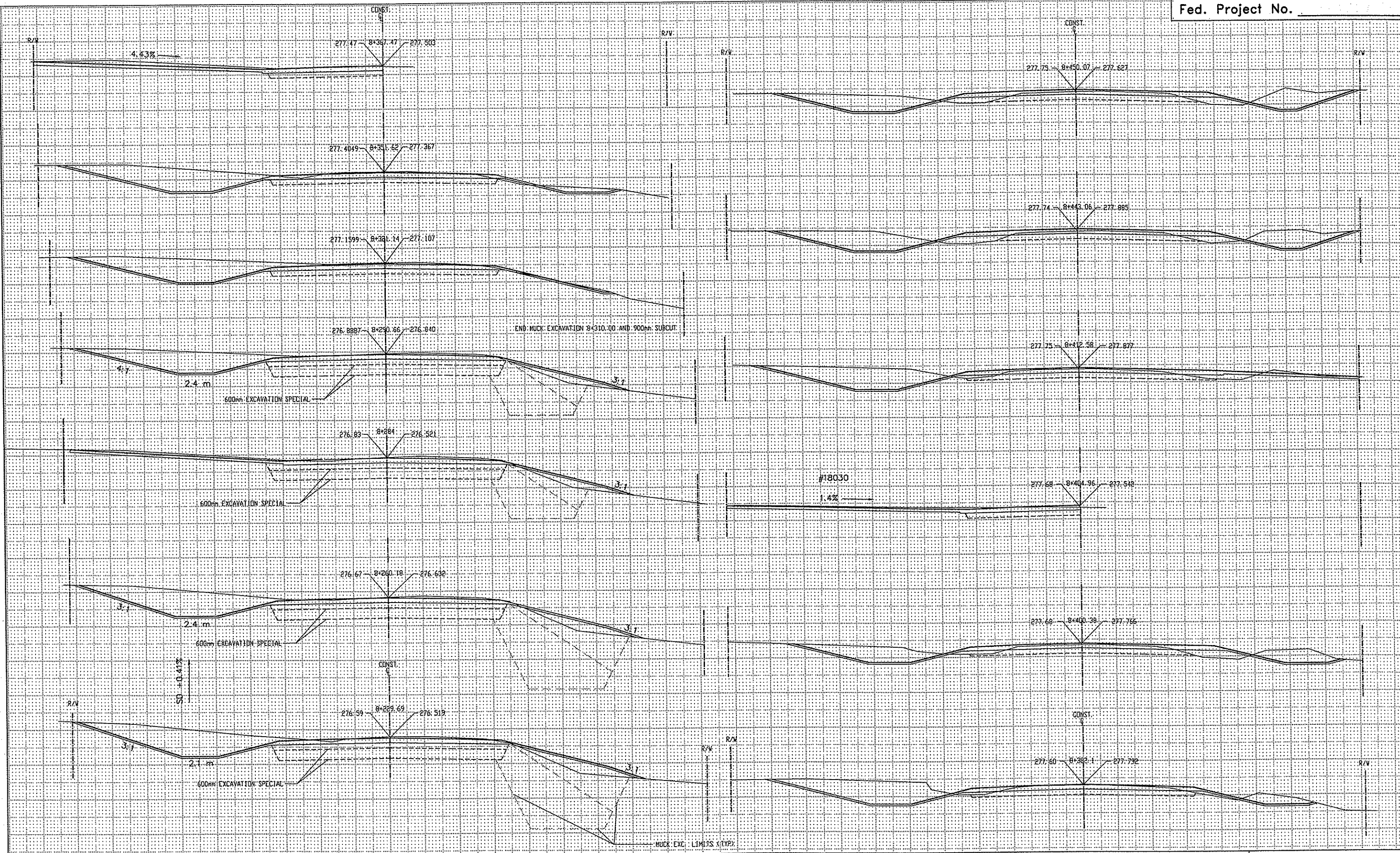

NO	DATE	BY	CKD	APPR	REVISION



I HEREBY CERTIFY THAT THIS PLAN WAS PREPARED BY ME OR UNDER MY DIRECT SUPERVISION AND THAT I AM A DULY REGISTERED PROFESSIONAL ENGINEER UNDER THE LAWS OF THE STATE OF MINNESOTA.

Albert

DATE 04/20/00 REG. NO. 25066

DRAWN BY: MN DATE 04/20/00
 DESGN BY: KGJ DATE 04/20/00
 CHECKED BY: LAR DATE 04/20/00



ANOKA COUNTY
 HIGHWAY DEPT.

STATE PROJECT NO. _____
 STATE AID PROJECT NO. 02-622-27
 STATE AID PROJECT NO. 02-683-01
 COUNTY PROJECT NO. _____

CROSS- SECTION
 STA 8+229.690 TO 8+450.070
 Sheet 46 of 56 Sheets

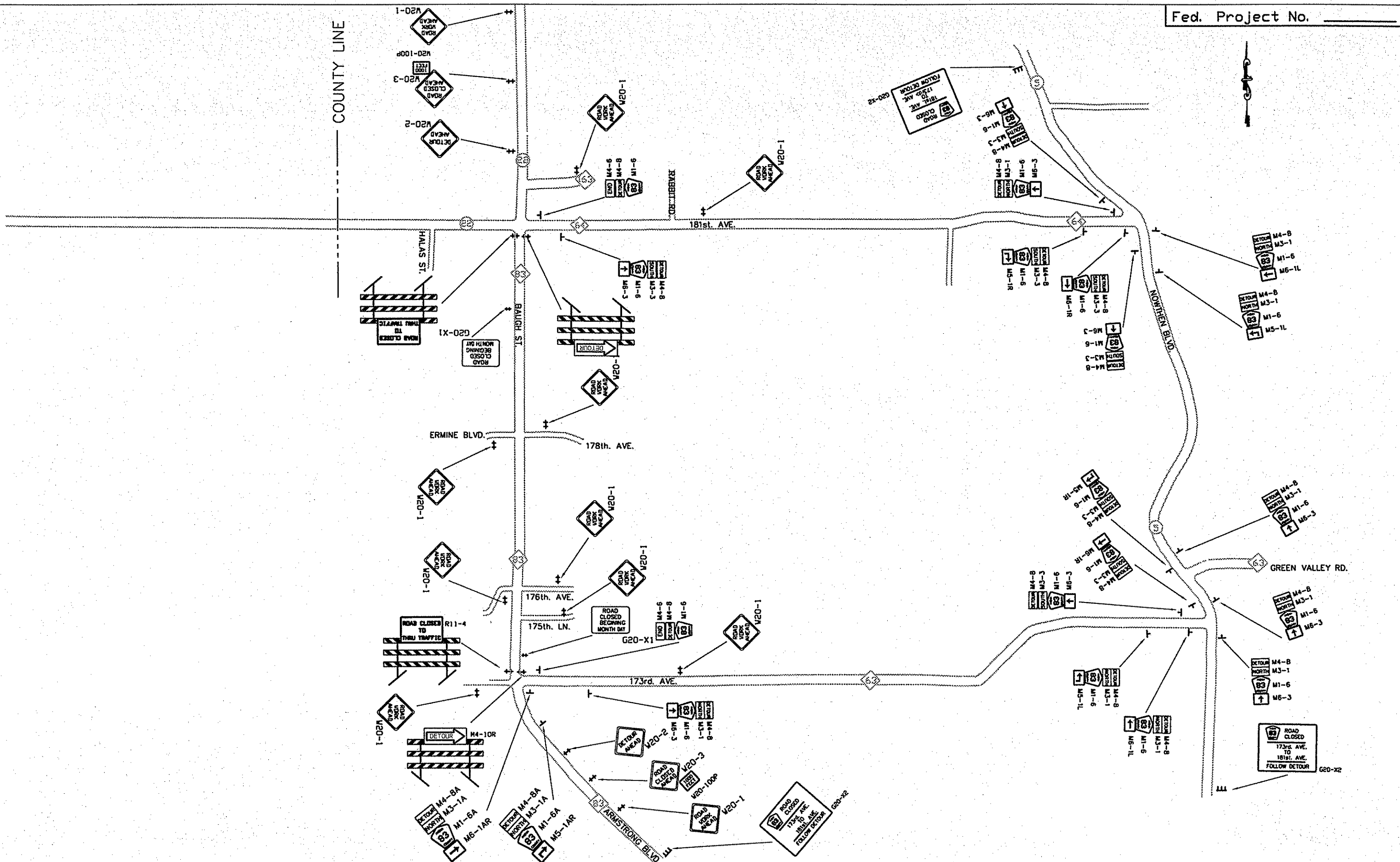

NO	DATE	BY	CHKD	APPR	REVISION



I HEREBY CERTIFY THAT THIS PLAN WAS PREPARED BY ME OR UNDER MY DIRECT SUPERVISION AND THAT I AM A DULY REGISTERED PROFESSIONAL ENGINEER UNDER THE LAWS OF THE STATE OF MINNESOTA.

[Signature]

DATE 04-20-00 REG. NO. 25066

DRAWN BY: D.M. DATE: 1/00
 DESIGN BY: _____ DATE: _____
 CHECKED BY: _____ DATE: _____



**ANOKA COUNTY
 HIGHWAY DEPT.**

STATE PROJECT NO. _____
 STATE AID PROJECT NO. 02-683-01
 STATE AID PROJECT NO. 02-622-27
 COUNTY PROJECT NO. _____

C.R. 83
 DETOUR PLAN

Sheet 48 of 56 Sheets

M. U. T. C. D. CODE	SIZE	INSERT	QUANTITY
W20-1	48" x 48"		• 11
W20-2	48" x 48"		• 2
W20-3	48" x 48"		• 2
W20-100P	24" x 18"		
M4-10L TYPE III	48" x 18" 8 FOOT		• 1
M4-10R TYPE III	48" x 18" 8 FOOT		• 1
R11-4 TYPE III	60" x 30" 8 FOOT		• 1
R11-4 TYPE III	60" x 30" 8 FOOT		• 1

M. U. T. C. D. CODE	SIZE	INSERT	QUANTITY
G20-X2	96" x 84"		• 2
G20-X2	96" x 84"		• 1
M4-8A	24" x 12"		• 2
M3-1A	24" x 12"		• 2
M1-6A	24" x 24"		• 5
	21" x 15"		• 1
			• 1
M4-8A	24" x 12"		• 2
M3-3A	24" x 12"		• 2
M1-6A	24" x 24"		• 4
	21" x 15"		
M4-6A	24" x 12"		• 2
M4-8A	24" x 12"		
M1-6A	24" x 24"		
G20-X1	60" x 48"		• 2

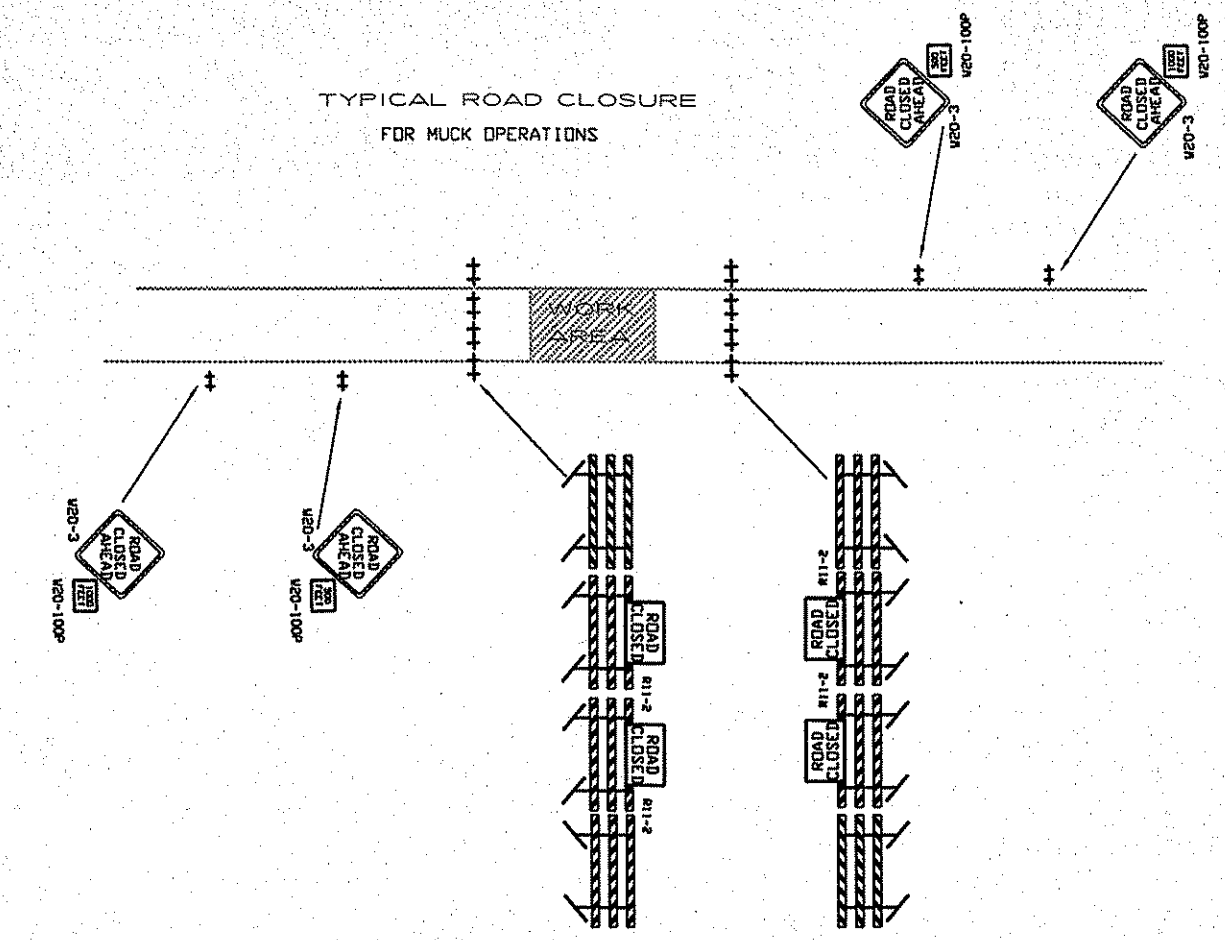

* SIGNS TO BE INSTALLED A MINIMUM OF SEVEN DAYS PRIOR TO ACTUAL CLOSING DATE OF ROAD CLOSURE AND IMPLEMENTATION OF DETOUR SIGN. SIGNS TO BE REMOVED AT TIME OF DETOUR INSTALLATION.

NOTES:

- 1) ALL BARRICADES SHALL BE PROPERLY WEIGHTED WITH SANDBAGS.
- 2) ALL BARRICADES SHALL HAVE REFLECTIVE MATERIAL ON BOTH SIDES.
- 3) ALL BARRICADE MARKINGS SHALL BE SLANTED IN ACCORDANCE WITH THE MINNESOTA MANUAL ON UNIFORM TRAFFIC CONTROL DEVICES, INCLUDING THE FIELD MANUAL DATED APRIL 1995.
- 4) ALL TRAFFIC CONTROL DEVICES SHALL CONFORM TO THE MOST RECENT EDITION OF THE MINNESOTA MANUAL ON UNIFORM TRAFFIC CONTROL DEVICES, INCLUDING THE FIELD MANUAL DATED JANUARY 1998
- 5) ADDITIONS OR CHANGES TO THIS PLAN MAY BE MADE AS DETERMINED BY THE ENGINEER.

QUANTITIES FOR TYPICAL ROAD CLOSURES

M. U. T. C. D. CODE	SIZE	INSERT	QUANTITY
R11-2	48" x 30"		• 2
TYPE III	8 FOOT		• 2
R11-2	48" x 30"		• 2
TYPE III	8 FOOT		• 2
TYPE III	8 FOOT		• 4
W20-3	48" x 48"		• 2
W20-100P	24" x 18"		
W20-3	48" x 48"		• 2
W20-100P	24" x 18"		

NO	DATE	BY	CHKD	APPR	REVISION



I HEREBY CERTIFY THAT THIS PLAN WAS PREPARED BY ME OR UNDER MY DIRECT SUPERVISION AND THAT I AM A DULY REGISTERED PROFESSIONAL ENGINEER UNDER THE LAWS OF THE STATE OF MINNESOTA.

Allyson

DATE 04-20-00 REG. NO. 25086

DRAWN BY D.M. DATE 1/00
 DESIGN BY DATE
 CHECKED BY DATE



ANOKA COUNTY
 HIGHWAY DEPT.

STATE PROJECT NO. _____
 STATE AID PROJECT NO. 02-683-01
 STATE AID PROJECT NO. 02-622-27
 COUNTY PROJECT NO. _____

C.R. 83
 DETOUR PLAN
 Sheet 49 of 56 Sheets

M. U. T. C. D. CODE	SIZE	INSERT	QUANTITY
W20-1	48" x 48"		• 2
W20-2	48" x 48"		• 1
W20-3	48" x 48"		• 1
W20-100P	24" x 18"		• 1
W20-3	48" x 48"		• 1
W20-100P	24" x 18"		• 1
M4-10L TYPE III	48" x 18" 8 FOOT		• 1
M4-10R TYPE III	48" x 18" 8 FOOT		• 1
R11-3 TYPE III	60" x 30" 8 FOOT		• 1
R11-4 TYPE III	60" x 30" 8 FOOT		• 1

M. U. T. C. D. CODE	SIZE	INSERT	QUANTITY
G20-X2	96" x 84"		• 2
G20-X2	96" x 84"		• 1
M4-8A	24" x 12"		• 2
M3-4A	24" x 12"		• 2
M1-6A	24" x 24"		• 5
	21" x 15"		• 1
M4-8A	24" x 12"		• 1
M3-2A	24" x 12"		• 1
M1-6A	24" x 24"		• 3
	21" x 15"		• 3
M4-6A	24" x 12"		• 2
M4-8A	24" x 12"		• 2
M1-6A	24" x 24"		• 2
	21" x 15"		• 2
G20-X1	60" x 48"		• 2
R11-4	60" x 30"		• 2
TYPE III	8 FOOT		• 2

TEXT TO BE DETERMINED AT TIME OF INSTALLATION OF DETOUR.

TEXT TO BE DETERMINED AT TIME OF INSTALLATION OF DETOUR.

TYPICAL ROAD CLOSURE FOR MUCK OPERATIONS

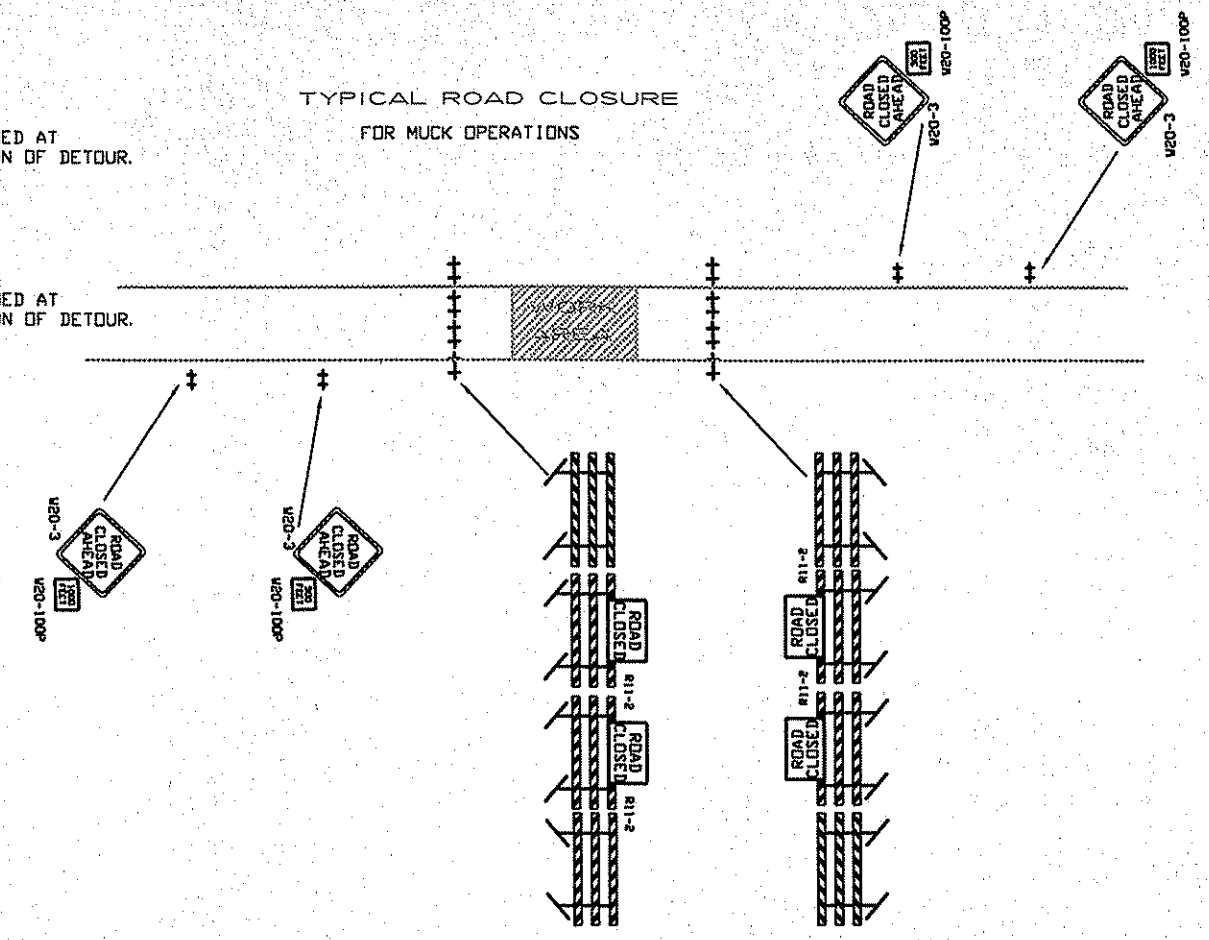

* SIGNS TO BE INSTALLED A MINIMUM OF SEVEN DAYS PRIOR TO ACTUAL CLOSING DATE OF ROAD CLOSURE AND IMPLEMENTATION OF DETOUR SIGN. SIGNS TO BE REMOVED AT TIME OF DETOUR INSTALLATION.

NOTES:

- 1) ALL BARRICADES SHALL BE PROPERLY WEIGHTED WITH SANDBAGS.
- 2) ALL BARRICADES SHALL HAVE REFLECTIVE MATERIAL ON BOTH SIDES.
- 3) ALL BARRICADE MARKINGS SHALL BE SLANTED IN ACCORDANCE WITH THE MINNESOTA MANUAL ON UNIFORM TRAFFIC CONTROL DEVICES, INCLUDING THE FIELD MANUAL DATED APRIL 1995.
- 4) ALL TRAFFIC CONTROL DEVICES SHALL CONFORM TO THE MOST RECENT EDITION OF THE MINNESOTA MANUAL ON UNIFORM TRAFFIC CONTROL DEVICES, INCLUDING THE FIELD MANUAL DATED JANUARY 1998.
- 5) ADDITIONS OR CHANGES TO THIS PLAN MAY BE MADE AS DETERMINED BY THE ENGINEER.

QUANTITIES FOR TYPICAL ROAD CLOSURES

M. U. T. C. D. CODE	SIZE	INSERT	QUANTITY
R11-2	48" x 30"		• 2
TYPE III	8 FOOT		• 2
R11-2	48" x 30"		• 2
TYPE III	8 FOOT		• 2
TYPE III	8 FOOT		• 4
W20-3	48" x 48"		• 2
W20-100P	24" x 18"		• 2
W20-3	48" x 48"		• 2
W20-100P	24" x 18"		• 2

NO	DATE	BY	CHKD	APPR	REVISION

NAME: S:\5830\PROJ\026227\PLAN\TRAFFIC (04-20-00)



I HEREBY CERTIFY THAT THIS PLAN WAS PREPARED BY ME OR UNDER MY DIRECT SUPERVISION AND THAT I AM A DULY REGISTERED PROFESSIONAL ENGINEER UNDER THE LAWS OF THE STATE OF MINNESOTA.

Allyson

DATE 04-20-00 REG. NO. 25066

DRAWN BY: D.M. DATE: 1/00
 DESIGN BY: DATE: _____
 CHECKED BY: DATE: _____



ANOKA COUNTY
HIGHWAY DEPT.

STATE PROJECT NO. _____
 STATE AID PROJECT NO. 02-683-01
 STATE AID PROJECT NO. 02-622-27
 COUNTY PROJECT NO. _____

C.R. 22
DETOUR PLAN

Sheet 51 of 58 Sheets

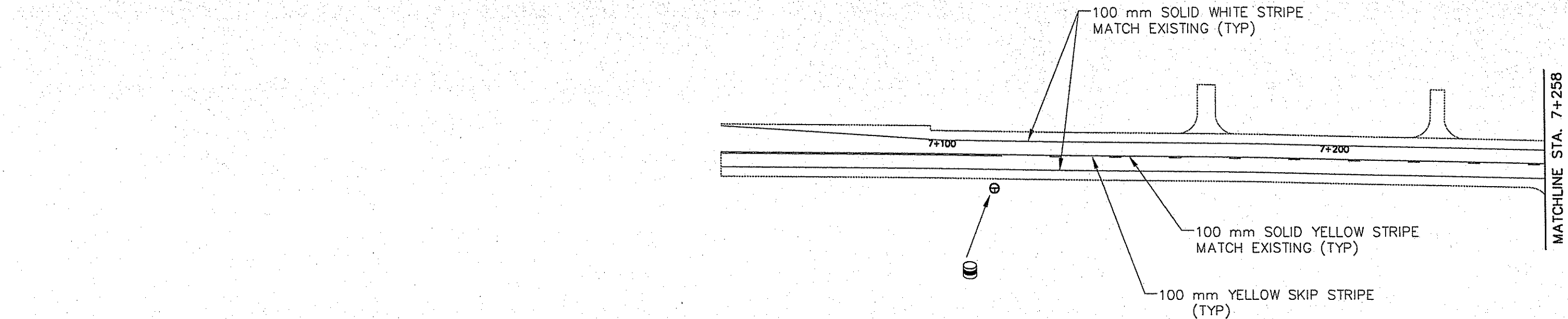

TYPICAL BY-PASS LANE STRIPING

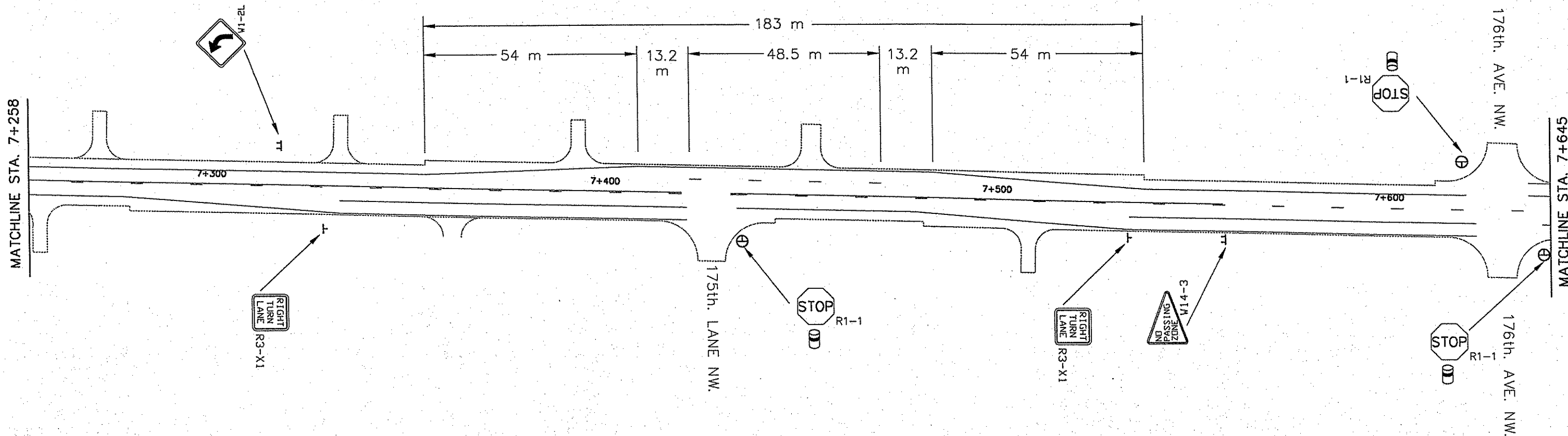

NO	DATE	BY	CKD	APPR	REVISION



I HEREBY CERTIFY THAT THIS PLAN WAS PREPARED BY ME OR UNDER MY DIRECT SUPERVISION AND THAT I AM A DULY REGISTERED PROFESSIONAL ENGINEER UNDER THE LAWS OF THE STATE OF MINNESOTA.

[Signature]

DATE 4/21/00 REG. NO. 26826

DRAWN BY: D.M. DATE: 1/00

DESIGN BY: _____ DATE: _____

CHECKED BY: _____ DATE: _____



ANOKA COUNTY
HIGHWAY DEPT.

STATE PROJECT NO. _____

STATE AID PROJECT NO. 02-683-01

STATE AID PROJECT NO. 02-622-27

COUNTY PROJECT NO. _____

PERMANENT
SIGNING/STRIPING

Sheet 52 of 56 Sheets

MATCHLINE STA. 7+645

MATCHLINE STA. 8+032

MATCHLINE STA. 8+032

MATCHLINE STA. 8+420

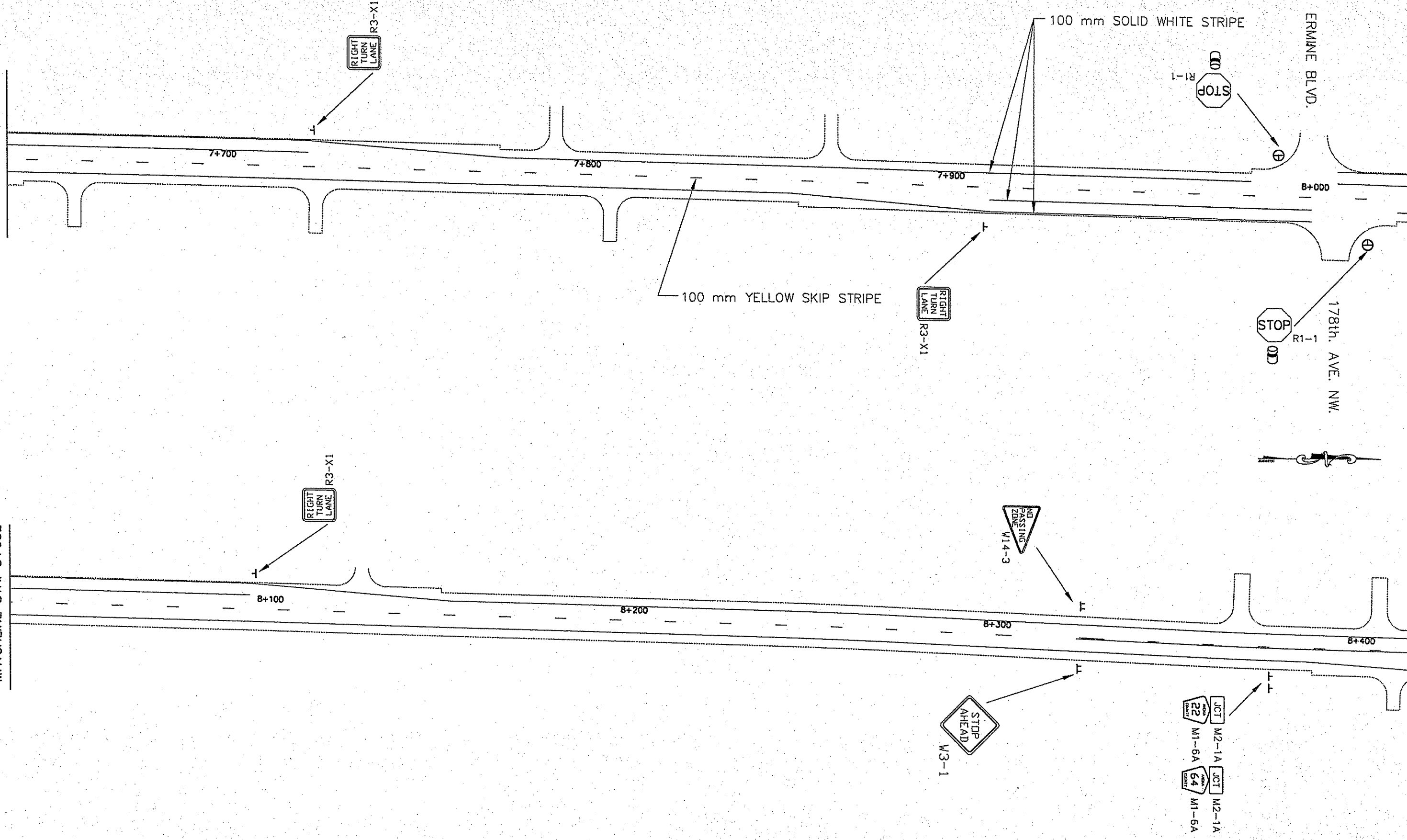

NO	DATE	BY	CHKD	APPR	REVISION



I HEREBY CERTIFY THAT THIS PLAN WAS PREPARED BY ME OR UNDER MY DIRECT SUPERVISION AND THAT I AM A DULY REGISTERED PROFESSIONAL ENGINEER UNDER THE LAWS OF THE STATE OF MINNESOTA.

Kristen Olson
 DATE 4/24/02 REG. NO. 26826

DRAWN BY D.M. DATE 1/00
 DESIGN BY _____ DATE _____
 CHECKED BY _____ DATE _____



**ANOKA COUNTY
 HIGHWAY DEPT.**

STATE PROJECT NO. _____
 STATE AID PROJECT NO. 02-683-01
 STATE AID PROJECT NO. 02-622-27
 COUNTY PROJECT NO. _____

**PERMANENT
 SIGNING/STRIPING**

Sheet 53 of 56 Sheets

MATCHLINE STA. 20+700

MATCHLINE STA. 8+420

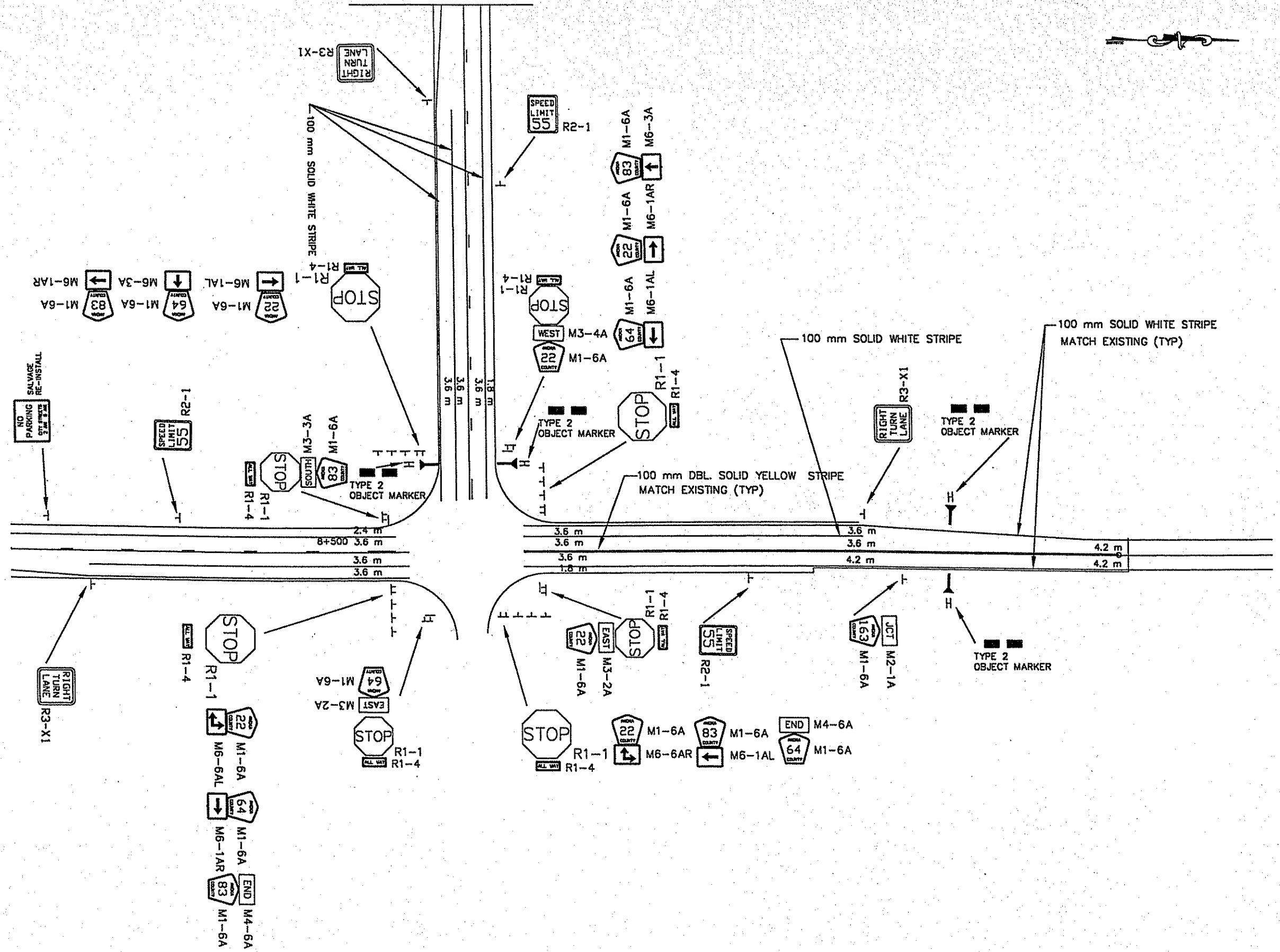

NO	DATE	BY	CKD	APPR	REVISION



I HEREBY CERTIFY THAT THIS PLAN WAS PREPARED BY ME OR UNDER MY DIRECT SUPERVISION AND THAT I AM A DULY REGISTERED PROFESSIONAL ENGINEER UNDER THE LAWS OF THE STATE OF MINNESOTA.

[Signature]
 DATE 4/24/00 REG. NO. 26826

DRAWN BY D.M. DATE 1/00
 DESIGN BY _____ DATE _____
 CHECKED BY _____ DATE _____



ANOKA COUNTY
 HIGHWAY DEPT.

STATE PROJECT NO. _____
 STATE AID PROJECT NO. 02-683-01
 STATE AID PROJECT NO. 02-622-27
 COUNTY PROJECT NO. _____

PERMANENT
 SIGNING/STRIPING
 Sheet 54 of 56 Sheets

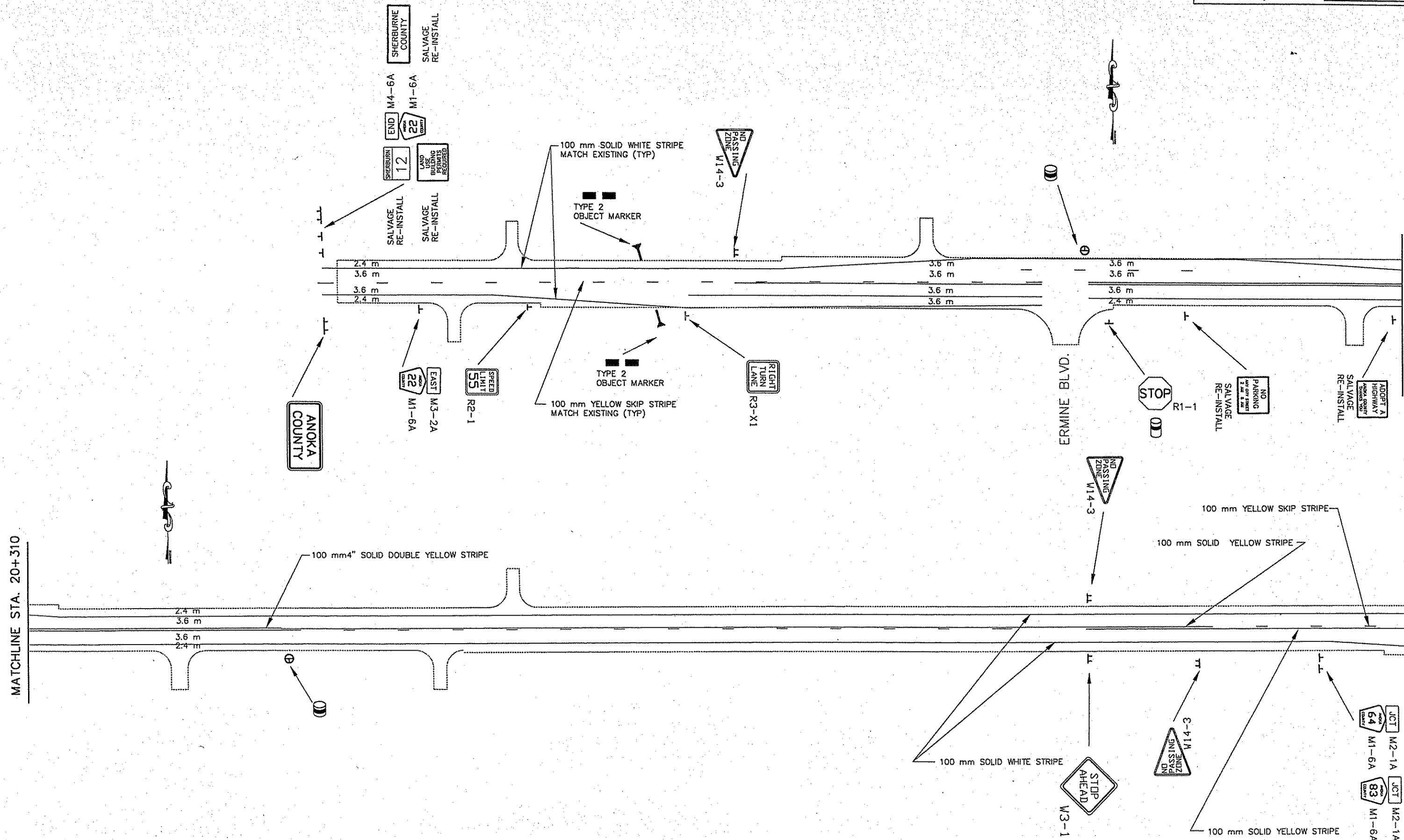

MATCHLINE STA. 20+310

MATCHLINE STA. 20+310

MATCHLINE STA. 20+700

ANOKA COUNTY

SHERBURNE COUNTY
SALVAGE RE-INSTALL

END M4-6A
M1-6A

SHERBURNE 12
LAND BUILDING PERMITS REQUIRED

SALVAGE RE-INSTALL
SALVAGE RE-INSTALL

EAST 22
M3-2A
M1-6A

SPEED LIMIT 55
R2-1

RIGHT TURN LANE
R3-X1

STOP R1-1

NO PARKING
SALVAGE RE-INSTALL

ADOPT A HIGHWAY
SALVAGE RE-INSTALL

JCT 64
M1-6A

JCT 83
M2-1A
M1-6A

I HEREBY CERTIFY THAT THIS PLAN WAS PREPARED BY ME OR UNDER MY DIRECT SUPERVISION AND THAT I AM A DULY REGISTERED PROFESSIONAL ENGINEER UNDER THE LAWS OF THE STATE OF MINNESOTA.
[Signature]
DATE 4/24/00 REG. NO. 26826

DRAWN BY D.M. DATE 1/00
DESIGN BY DATE
CHECKED BY DATE



ANOKA COUNTY HIGHWAY DEPT.

STATE PROJECT NO. _____
STATE AID PROJECT NO. 02-683-01
STATE AID PROJECT NO. 02-622-27
COUNTY PROJECT NO. _____

PERMANENT SIGNING/STRIPING
Sheet 55 of 56 Sheets

NO	DATE	BY	CHKD	APPR	REVISION

NAME: S:\SBSKPRD\JAG000000\000000\026000.BWG

M. U. T. C. D. CODE	SIZE	SIZE	INSERT	QTY	PANEL AREA		TOTAL SQ. FT.	TOTAL SQ. mm	MOUNTING POST PER INSTALLATION	MOUNTING HEIGHT	
					FT ²	mm ²					
R1-1	30" x 30"	762mm X 762mm		6	6.25	0.580	37.50	3.483	1	7.0	
R1-1	36" x 36"	914mm X 914mm		4	9.00	0.836	36.00	3.344	2	7.0	
R1-1	48" x 48"	1219mm X 1219mm		4	16.00	1.486	64.00	5.945	2	7.0	
R1-4	18" x 6"	457mm X 457mm			8	.75	0.070	6.00	0.557	①	
R2-1	24" x 30"	610mm X 760mm		4	5.00	0.464	15.00	1.393	③	7.0	
R3-X1	30" x 30"	762mm X 762mm		9	6.25	0.580	37.5	3.483	1	7.0	
W1-2L	30" x 30"	762mm X 762mm		1	6.25	0.580	6.25	5.80	1	7.0	
W3-1	48" x 48"	1219mm X 1219mm		2	16.00	1.486	32.00	2.932	2	7.0	
W14-3	36"x48"x48"	914mmX1219mmX1219mm		5	6.00	.0557	24.00	2.229	2	7.0	
I2-5	48 x 24"	1.220 mm X 0.610 mm		1	8.00	0.743	8.00	0.743	2	7.0	
					SUB-TOTAL		290.00	24.735			

- ① MOUNTED BELOW R1-1 (36"x36" and 48"x48")
 ② MOUNTED BELOW R1-1 (30"x30")
 ③ MOUNTED BACK TO BACK WITH W14-3
 ④ MOUNTED BACK TO BACK WITH R1-1

NOTE:

- 1.) LOCATIONS OF 'NO PASSING ZONES' ARE APPROXIMATE. EXACT LOCATIONS WILL BE DETERMINED IN THE FIELD
 2.) ALL TRAFFIC CONTROL DEVICES SHALL CONFORM TO THE MOST RECENT EDITION OF THE MINNESOTA MANUAL ON UNIFORM TRAFFIC CONTROL DEVICES, INCLUDING THE FIELD MANUAL DATED JAN. 1998

M. U. T. C. D. CODE	SIZE	SIZE	INSERT	QTY	PANEL AREA		TOTAL SQ. FT.	TOTAL SQ. mm	MOUNTING POST PER INSTALLATION	MOUNTING HEIGHT	
					FT ²	mm ²					
	21" x 15"	530mm X 380mm	JCT M2-1A	1	2.50	0.232	2.50	0.232			
			EAST M3-2A	2	2.00	0.186	2.00	0.186		④	
			WEST M3-4A	1	2.00	0.186	2.00	0.186		④	
	24" x 12"	610mm X 305mm	END M4-6A	1	2.00	0.186	2.00	0.186			
M1-6A	24" x 24"	610mm X 610mm		9	4.00	0.372	36.00	3.348	1	7.0	
	21" x 15"	530mm X 380mm	→ M6-1AR	1	2.20	0.204	2.20	0.204			
			← M6-1AL	1	2.20	0.204	2.20	0.204			
			↗ M6-6AR	1	2.20	0.204	2.20	0.204			
			↘ M6-6AL	1	2.20	0.204	2.20	0.204			
	24" x 15"	530mm X 380mm	JCT M2-1A	2	2.50	0.232	5.00	0.465			
	24" x 12"	610mm X 305mm	EAST M3-2A	1	2.00	0.186	2.00	0.186		④	
M1-6A	24" x 24"	610mm X 610mm	END M4-6A	1	2.00	0.186	2.00	0.186			
	21" x 15"	530mm X 380mm		7	4.00	0.372	28.00	2.601	1	7.0	
			→ M6-1AR	1	2.20	0.204	2.20	0.204			
			← M6-1AL	1	2.20	0.204	2.20	0.204			
			↑ M6-3A	1	2.20	0.204	2.20	0.204			
	24" x 15"	530mm X 380mm	JCT M2-1A	1	2.50	0.232	2.50	0.232			
	24" x 12"	610mm X 305mm	END M4-6A	1	2.00	0.186	2.00	0.186			
M1-6A	24" x 24"	610mm X 610mm		6	4.00	0.372	24.00	2.232	1	④ 7.0	
	21" x 15"	530mm X 380mm	→ M6-1AR	1	2.20	0.204	2.20	0.204			
			← M6-1AL	1	2.20	0.204	2.20	0.204			
			↑ M6-3A	1	2.20	0.204	2.20	0.204			
M2-1A	24" x 15"	530mm X 380mm	JCT	1	2.50	0.232	2.50	0.232			
M1-6A	24" x 24"	610mm X 610mm		1	4.00	0.372	4.00	0.372			
DELINEATOR	4"DIA x 15"	101.6mm DIA. X 38.1mm		6	1.31	0.122	7.86	0.730		②	
TERMINAL	4"DIA x 4"	101.6mm DIA. X 38.1mm		3	0.99	0.092	2.97	0.276	1	5.0	
TYPE 2 OBJECT MARKER	6" x 12"	530mm X 380mm		12	0.44	0.041	5.28	0.491	1	5.0	
							SUB-TOTAL (COLUMN 2)	150.83	14.018		
							SUB-TOTAL (COLUMN 1)	290.00	31.923		
							TOTAL	440.83	45.941		

NO	DATE	BY	CHKD	APPR	REVISION



I HEREBY CERTIFY THAT THIS PLAN WAS PREPARED BY ME OR UNDER MY DIRECT SUPERVISION AND THAT I AM A DULY REGISTERED PROFESSIONAL ENGINEER UNDER THE LAWS OF THE STATE OF MINNESOTA.
 DATE 4/21/00 REG. NO. 26826

DRAWN BY: D.M. DATE 1/00
 DESIGN BY: DATE
 CHECKED BY: DATE



ANOKA COUNTY
 HIGHWAY DEPT.

STATE PROJECT NO. _____
 STATE AID PROJECT NO. 02-683-01
 STATE AID PROJECT NO. 02-622-27
 COUNTY PROJECT NO. _____

PERMANENT
 SIGNING QUANTITIES
 Sheet 56 of 56 Sheets