

STATEMENT OF ESTIMATED QUANTITIES							CR 13 2/22/2013	
ITEM NO.		ITEM	TAB	NOTE NO.	UNIT	TOTAL EST. QUANT.	UNIT PRICE	COST EST.
2021.501	00010	MOBILIZATION		29	LUMP SUM	1	\$28,069.20	\$28,069.20
2021.601	00050	RAILROAD PROTECTIVE SERVICES	A	1	LUMP SUM	1	\$3,000.00	\$3,000.00
2104.501	00010	REMOVE PIPE CULVERTS	B	30	LIN FT	445	\$9.80	\$4,361.00
2104.505	00120	REMOVE BITUMINOUS PAVEMENT	C	2	SQ YD	703	\$2.83	\$1,989.49
2104.513	00011	SAW BITUMINOUS PAVEMENT FULL DEPTH	D	2,3	LIN FT	296	\$2.96	\$876.16
2104.523	00543	SALVAGE SIGN TYPE C			EACH	15	\$45.55	\$683.25
2105.525	00010	TOPSOIL BORROW (LV)	E	5	CU YD	775	\$18.36	\$14,233.76
2105.602	00020	CONSTRUCT TURN LANE (FLINTWOOD ST) (P)		4	EACH	1	\$7,537.98	\$7,537.98
2105.602	00020	CONSTRUCT TURN LANE (236 TH) (P)		4	EACH	1	\$9,923.95	\$9,923.95
2105.602	00020	CONSTRUCT TURN LANE (CR 24) (P)		4	EACH	1	\$7,537.98	\$7,537.98
2105.602	00020	CONSTRUCT BYPASS LANE (HOLLY ST) (P)		4	EACH	1	\$16,244.29	\$16,244.29
2105.602	00020	CONSTRUCT BYPASS LANE (FLINTWOOD ST) (P)		4	EACH	1	\$12,810.83	\$12,810.83
2105.602	00020	CONSTRUCT BYPASS LANE (UNIVERSITY) (P)		4	EACH	1	\$12,101.23	\$12,101.23
2105.602	00020	CONSTRUCT BYPASS LANE (236 TH) (P)		4	EACH	1	\$12,101.23	\$12,101.23
2123.503	00010	MOTOR GRADER	F	6	HOUR	24	\$130.74	\$3,137.76
2130.501	00010	WATER		7	M-GAL	193	\$19.89	\$3,838.77
2211.501	00050	AGGREGATE BASE CLASS 5	G	8	TON	1000	\$10.43	\$10,430.00
2221.501	00050	AGGREGATE SHOULDERING CLASS 5	H	9	TON	1138	\$13.24	\$15,068.44
2232.501	00050	MILL BITUMINOUS SURFACE (2") JOINTS	I	3,10	SQ YD	112	\$6.69	\$749.28
2331.604	00060	BITUMINOUS PAVEMENT RECLAMATION FULL DEPTH	J	11	SQ YD	29278	\$1.11	\$32,498.58
2331.607	00010	HAUL BIT PAVEMENT RECLAMATION (LV)		31	CU YD	500	\$6.00	\$3,000.00
2357.502	00010	BITUMINOUS MATERIAL FOR TACK COAT	K		GALLON	1997	\$2.37	\$4,732.89
2360.501	24500	TYPE SP 12.5 WEARING COURSE MIX (4, E)	L	4,12,28	TON	8922	\$58.33	\$502,576.26
2360.501	24200	TYPE SP 12.5 WEARING COURSE MIX (4, B)	M	13	TON	171	\$93.18	\$15,933.78
2451.509	00010	AGGREGATE BEDDING (LV)	N	14	CU YD	19	\$25.00	\$475.00
2501.511	20150	15" CS PIPE CULVERT	O	34	LIN FT	244	\$25.00	\$6,100.00
2501.515	90240	24" RC PIPE APRON	P	15	EACH	2	\$450.00	\$900.00
2501.521	90222	22" SPAN RC PIPE ARCH CULV CL IIA	Q	35	EACH	60	\$64.00	\$3,840.00
2501.521	90582	58" SPAN RC PIPE-ARCH CULV CL IIIA	R	16	LIN FT	56	\$130.00	\$7,280.00
2501.525	90220	22" SPAN RC PIPE ARCH APRON	S	35	EACH	2	\$700.00	\$1,400.00
2501.525	90580	58" SPAN RC PIPE-ARCH APRON	T	16	EACH	2	\$900.00	\$1,800.00
2501.561	90243	24" RC PIPE CULVERT DES 3006 CL III	U	15	LIN FT	72	\$70.00	\$5,040.00
2501.567	04150	15" GS SAFETY APRON AND GRATE DES 3148	V	34	EACH	12	\$450.00	\$5,400.00
2506.503	00010	RECONSTRUCT DRAINAGE STRUCTURE	W	36	LIN FT	11	\$288.00	\$3,168.00
2506.516	00010	CASTING ASSEMBLY	X	36	EACH	5	\$550.00	\$2,750.00
2506.522	00011	ADJUST FRAM RING AND CASTING	Y	36	EACH	3	\$415.00	\$1,245.00
2511.501	00012	RANDOM RIPRAP CLASS II	Z	17	CU YD	14	\$99.90	\$1,398.60
2511.515	00014	GEOTEXTILE FILTER TYPE IV	AA	32	SQ YD	65	\$3.00	\$194.67
2540.602	00140	INSTALL MAIL BOX SUPPORT	BB	18	EACH	30	\$105.00	\$3,150.00
2540.602	00155	RELOCATE MAIL BOX SUPPORT		33	EACH	6	\$92.54	\$555.24
2563.601	00010	TRAFFIC CONTROL		19	LUMP SUM	1	\$5,802.27	\$5,802.27
2563.601	00200	DETOUR SIGNING		20	LUMP SUM	1	\$10,227.00	\$10,227.00
2563.613	01100	PORTABLE CHANGEABLE MESSAGE SIGN	CC	21	UNIT DAY	14	\$150.00	\$2,100.00
2564.533	00130	FURNISH SIGN PANEL TYPE C			SQ FT	38.25	\$33.53	\$1,282.52
2564.536	00013	INSTALL SIGN PANEL TYPE C			EACH	13	\$95.56	\$1,242.28
2573.508	00010	BITUMINOUS LINED FLUME	DD	22	SQ YD	13	\$22.86	\$297.18
2573.502	00040	SILT FENCE TYPE MACHINE SLICED	EE	21, 23	LIN FT	4240	\$1.37	\$5,808.80
2573.602	00090	CULVERT PROTECTION	FF	31	EACH	7	\$150.00	\$1,050.00
2575.505	00050	SODDING TYPE SALT RESISTANT		37, 31	SQ YD	1404	\$2.86	\$4,015.44
2575.523	00010	EROSION CONTROL BLANKET CATEGORY 00	GG	24, 31	SQ YD	7083	\$2.00	\$14,166.00
2575.571	00010	RAPID STABILIZATION METHOD 3	HH	25, 31	MGAL	17	\$242.00	\$4,114.00
2581.501	00010	REMOVABLE PREFORMED PLASTIC MARKING	II	26	LIN FT	817	\$1.50	\$1,225.50
2582.502	21124	24" WHITE PREF THERMOPLASTIC		27	LIN FT	24	\$18.65	\$447.60
2582.502	41104	4" SOLID LINE WHITE - EPOXY		27	LIN FT	21285	\$0.22	\$4,682.70
2582.502	41204	4" BROKEN LINE WHITE-EPOXY		27	LIN FT	160	\$0.22	\$35.20
2582.502	42104	4" SOLID LINE YELLOW - EPOXY		27	LIN FT	2534	\$0.24	\$608.16
2582.502	42204	4" BROKEN LINE YELLOW-EPOXY		27	LIN FT	1350	\$0.22	\$297.00
2582.502	42404	4" DOUBLE SOLID LINE YELLOW - EPOXY		27	LIN FT	3722	\$0.46	\$1,712.12
2582.602	08010	PAVT MSSG (RR CROSSING) PREF THERMOPLASTIC		27	EACH	2	\$1,400.00	\$2,800.00
							TOTAL	\$830,046.41

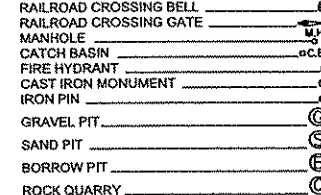

PLAN SYMBOLS

- COUNTY LINE \_\_\_\_\_
- TOWNSHIP OR RANGE LINE \_\_\_\_\_
- SECTION LINE \_\_\_\_\_
- QUARTER LINE \_\_\_\_\_
- SIXTEENTH LINE \_\_\_\_\_
- RIGHT OF WAY LINE \_\_\_\_\_
- SLOPE BASEMENT \_\_\_\_\_
- EXISTING RIGHT OF WAY \_\_\_\_\_
- PROPERTY LINE \_\_\_\_\_
- CORPORATE OR CITY LIMITS \_\_\_\_\_
- RETAINING WALL \_\_\_\_\_
- RAILROAD \_\_\_\_\_
- RAILROAD RIGHT OF WAY \_\_\_\_\_
- RIVER OR CREEK \_\_\_\_\_
- DRAINAGE DITCH \_\_\_\_\_
- CULVERT \_\_\_\_\_
- DROP INLET \_\_\_\_\_
- GUARD RAIL \_\_\_\_\_
- BARBED WIRE FENCE \_\_\_\_\_
- WOVEN WIRE FENCE \_\_\_\_\_
- CHAIN LINK FENCE \_\_\_\_\_
- WOOD FENCE \_\_\_\_\_
- STONE WALL OR FENCE \_\_\_\_\_
- HEDGE \_\_\_\_\_

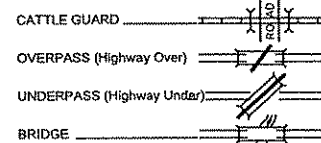
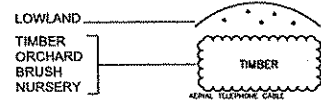

UTILITY SYMBOLS

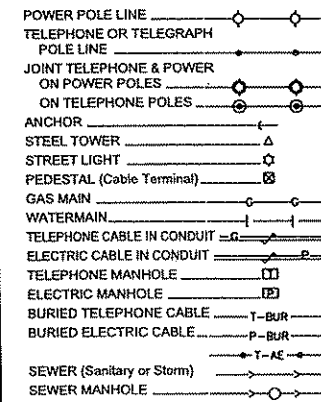

SCALES

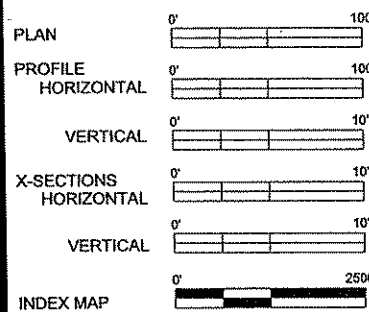

# MINNESOTA DEPARTMENT OF TRANSPORTATION

## ANOKA COUNTY

CONSTRUCTION PLAN FOR \_\_\_\_\_ RECLAIM AND OVERLAY, RTL / BYPASS CONSTRUCTION

LOCATED ON CSAH 13 FROM CR 103 / CEDAR DR. TO CSAH 24 / CR 73

13-13-13

GROSS LENGTH	10,212 FEET	1.93 MILES
BRIDGES-LENGTH	0.00 FEET	0.00 MILES
EXCEPTIONS-LENGTH	0.00 FEET	0.00 MILES
NET LENGTH	10212 FEET	1.93 MILES

CITIES OF BETHEL, EAST BETHEL,  
ST FRANCIS AND OAK GROVE

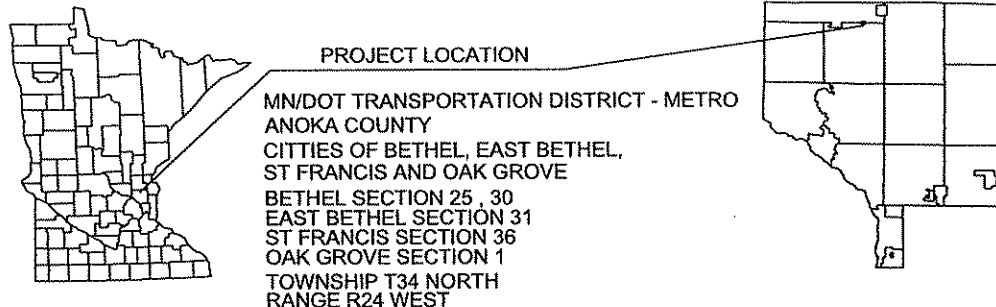
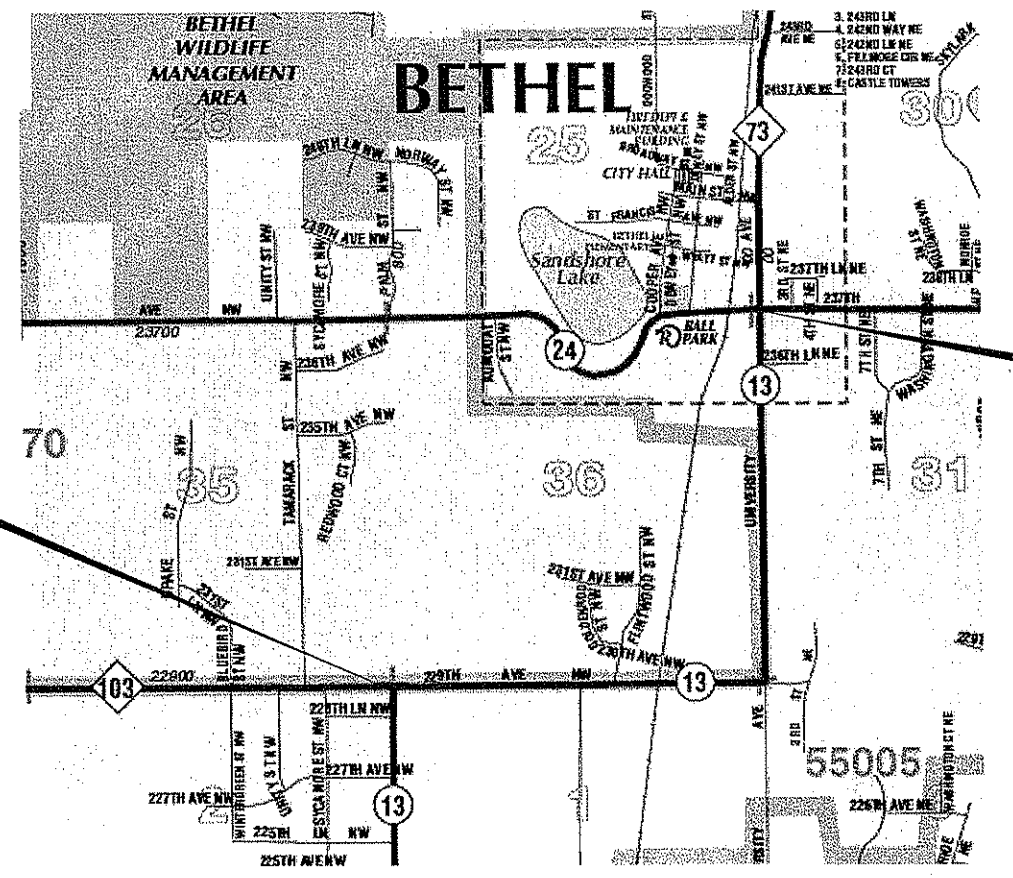

PROJECT LOCATION  
MN/DOT TRANSPORTATION DISTRICT - METRO  
ANOKA COUNTY  
CITIES OF BETHEL, EAST BETHEL,  
ST FRANCIS AND OAK GROVE  
BETHEL SECTION 25, 30  
EAST BETHEL SECTION 31  
ST FRANCIS SECTION 36  
OAK GROVE SECTION 1  
TOWNSHIP T34 NORTH  
RANGE R24 WEST

MINN. PROJ. NO. \_\_\_\_\_

GOVERNING SPECIFICATIONS

THE 2005 EDITION OF THE MINNESOTA DEPARTMENT OF TRANSPORTATION "STANDARD SPECIFICATIONS FOR CONSTRUCTION" SHALL GOVERN. ALL TRAFFIC CONTROL DEVICES SHALL CONFORM AND BE INSTALLED IN ACCORDANCE TO THE "MINNESOTA MANUAL ON UNIFORM TRAFFIC CONTROL DEVICES" (MNMUTCD), AND PART VI, OF THE MOST RECENT EDITION OF THE "FIELD MANUAL FOR TEMPORARY TRAFFIC CONTROL ZONE LAYOUTS."

INDEX

SHEET NO.	DESCRIPTION
1	TITLE SHEET
2	STATEMENT OF ESTIMATED QUANTITIES
3-4	CONSTRUCTION TABS
5	RTL / BYPASS TABULATIONS
6-7	RTL / BYPASS CALCULATIONS
8-9	CONSTRUCTION DETAILS
10-11	TYPICALS
12	ALIGNMENT / CORE INFORMATION
13-16	CONSTRUCTION PLAN
17-18	DETOUR LAYOUT (SEE SPECIAL PROVISIONS & NOTE #29)
19	PERMANENT MARKING TABULATION
20-25	SIGNING AND STRIPING LAYOUTS
26-27	SIGNING AND STRIPING DETAILS

THIS PLAN CONTAINS 27 SHEETS

DESIGN DESIGNATION

ESAL 20	886,000
R VALUE	50
ADT (2010) =	2430
Proj. ADT (2032) =	4750
Proj. HCADT (2032) =	807
Soil Factor	NA

--- TON DESIGN

Functional Classification A-MINOR ARTERIAL

No. of Traffic Lanes 2 No. of Parking Lanes 0

Design Speed --- MPH

Based on Stopping Sight Distance ---

Height of eye 3.5' Height of object 2.0'

Design Speed not achieved at:  
STA. --- TO STA. --- MPH ---

Approved: 3/14/2013  
ANOKA COUNTY ENGINEER

NO	DATE	BY	CKD	APPR	REVISION

I HEREBY CERTIFY THAT THIS PLAN WAS PREPARED BY ME OR UNDER MY DIRECT SUPERVISION AND THAT I AM A DULY LICENSED PROFESSIONAL ENGINEER UNDER THE LAWS OF THE STATE OF MINNESOTA.

PRINT NAME: ANDREW WITTER

SIGNATURE:

DATE: 3/7/13 LICENSE NO. 42757

DRAWN BY JF DATE 1/18/2013

DESIGN BY JF DATE 1/18/2013

CHECKED BY XX DATE XXXX

**ANOKA COUNTY**  
**HIGHWAY DEPT.**

STATE PROJECT NO. \_\_\_\_\_

STATE AID PROJECT NO. \_\_\_\_\_

CITY PROJECT NO. \_\_\_\_\_

COUNTY PROJECT NO. CP 13-13-13

TITLE SHEET

Sheet 1 of 27 Sheets

STATEMENT OF ESTIMATED QUANTITIES						
ITEM NO.		ITEM	TAB	NOTE NO.	UNIT	TOTAL EST. QUANT.
2021.501	00010	MOBILIZATION		29	LUMP SUM	1
2021.601	00050	RAILROAD PROTECTIVE SERVICES	A	1	LUMP SUM	1
2104.501	00010	REMOVE PIPE CULVERTS	B	30	LIN FT	445
2104.505	00120	REMOVE BITUMINOUS PAVEMENT	C	2	SQ YD	703
2104.513	00011	SAW BITUMINOUS PAVEMENT FULL DEPTH	D	2,3	LIN FT	296
2104.523	00543	SALVAGE SIGN TYPE C			EACH	15
2105.525	00010	TOPSOIL BORROW (LV)	E	5	CU YD	775
2105.602	00020	CONSTRUCT TURN LANE (FLINTWOOD ST) (P)		4	EACH	1
2105.602	00020	CONSTRUCT TURN LANE (236 TH) (P)		4	EACH	1
2105.602	00020	CONSTRUCT TURN LANE (CR 24) (P)		4	EACH	1
2105.602	00020	CONSTRUCT BYPASS LANE (HOLLY ST) (P)		4	EACH	1
2105.602	00020	CONSTRUCT BYPASS LANE (FLINTWOOD ST) (P)		4	EACH	1
2105.602	00020	CONSTRUCT BYPASS LANE (UNIVERSITY) (P)		4	EACH	1
2105.602	00020	CONSTRUCT BYPASS LANE (236 TH) (P)		4	EACH	1
2123.503	00010	MOTOR GRADER	F	6	HOUR	24
2130.501	00010	WATER		7	M-GAL	193
2211.501	00050	AGGREGATE BASE CLASS 5	G	8	TON	1000
2221.501	00050	AGGREGATE SHOULDERING CLASS 5	H	9	TON	1138
2232.501	00050	MILL BITUMINOUS SURFACE (2") JOINTS	I	3,10	SQ YD	112
2331.604	00060	BITUMINOUS PAVEMENT RECLAMATION FULL DEPTH	J	11	SQ YD	29278
2331.607	00010	HAUL BIT PAVEMENT RECLAMATION (LV)		31	CU YD	500
2357.502	00010	BITUMINOUS MATERIAL FOR TACK COAT	K		GALLON	1997
2360.501	24500	TYPE SP 12.5 WEARING COURSE MX (4, E)	L	4,12,28	TON	8922
2360.501	24200	TYPE SP 12.5 WEARING COURSE MX (4, B)	M	13	TON	171
2451.509	00010	AGGREGATE BEDDING (LV)	N	14	CU YD	19
2501.511	20150	15" CS PIPE CULVERT	O	34	LIN FT	244
2501.515	90240	24" RC PIPE APRON	P	15	EACH	2
2501.521	90222	22" SPAN RC PIPE ARCH CULV CL IIA	Q	35	EACH	60
2501.521	90582	58" SPAN RC PIPE-ARCH CULV CL IIA	R	16	LIN FT	56
2501.525	90220	22" SPAN RC PIPE ARCH APRON	S	35	EACH	2
2501.525	90580	58" SPAN RC PIPE-ARCH APRON	T	16	EACH	2
2501.561	90243	24" RC PIPE CULVERT DES 3006 CL III	U	15	LIN FT	72
2501.567	04150	15" GS SAFETY APRON AND GRATE DES 3148	V	34	EACH	12
2506.503	00010	RECONSTRUCT DRAINAGE STRUCTURE	W	36	LIN FT	11
2506.516	00010	CASTING ASSEMBLY	X	36	EACH	5
2506.522	00011	ADJUST FRAMRING AND CASTING	Y	36	EACH	3
2511.501	00012	RANDOM RIPRAP CLASS II	Z	17	CU YD	14
2511.515	00014	GEOTEXTILE FILTER TYPE IV	AA	32	SQ YD	65
2540.602	00140	INSTALL MAIL BOX SUPPORT	BB	18	EACH	30
2540.602	00155	RELOCATE MAIL BOX SUPPORT		33	EACH	6
2563.601	00010	TRAFFIC CONTROL		19	LUMP SUM	1
2563.601	00200	DETOUR SIGNING		20	LUMP SUM	1
2563.613	01100	PORTABLE CHANGEABLE MESSAGE SIGN	CC	21	UNIT DAY	14
2564.533	00130	FURNISH SIGN PANEL TYPE C			SQ FT	38.25
2564.536	00013	INSTALL SIGN PANEL TYPE C			EACH	13
2573.508	00010	BITUMINOUS LINED FLUME	DD	22	SQ YD	13
2573.502	00040	SILT FENCE TYPE MACHINE SLICED	EE	21, 23	LIN FT	4240
2573.602	00090	CULVERT PROTECTION	FF	31	EACH	7
2575.505	00050	SODDING TYPE SALT RESISTANT		37, 31	SQ YD	1404
2575.523	00010	EROSION CONTROL BLANKET CATEGORY 00	GG	24, 31	SQ YD	7083
2575.571	00010	RAPID STABILIZATION METHOD 3	HH	25, 31	MGAL	17
2581.501	00010	REMOVABLE PREFORMED PLASTIC MARKING	II	26	LIN FT	817
2582.502	21124	24" WHITE PREF THERMOPLASTIC		27	LIN FT	24
2582.502	41104	4" SOLID LINE WHITE - EPOXY		27	LIN FT	21285
2582.502	41204	4" BROKEN LINE WHITE-EPOXY		27	LIN FT	160
2582.502	42104	4" SOLID LINE YELLOW - EPOXY		27	LIN FT	2534
2582.502	42204	4" BROKEN LINE YELLOW-EPOXY		27	LIN FT	1350
2582.502	42404	4" DOUBLE SOLID LINE YELLOW - EPOXY		27	LIN FT	3722
2582.602	08010	PAVT MSSG (RR CROSSING) PREF THERMOPLASTIC		27	EACH	2

**NOTES**

- CONTRACTOR RESPONSIBLE TO CORRDINATE WITH RAIL ROAD FOR RXR PROTECTIVE SERVICES. PROTECTIVE SERVICES MUST BE PRESENT DURING ALL WORK IN AND AROUND RXR CROSSING R/W. RAILROAD R/W IS 50' BOTH SIDES FROM THE WEST RAIL OF TRACKS.
- BITUMINOUS DR WAYS TO BE SAWCUT, BITUMINOUS REMOVED, GRVL ADDED AS NESSASARY AND REPAVED. BITUMINOUS ROADWAY INSIDE RXR R/W TO BE CHUNKED OUT AND REMOVED AS DIRECTED BY THE ENGINEER.
- LOCATION TO BE DETERMINED BY ENGINEER.
- ITEMS INCLUDED IN THE RTL / BYPASS BY THE EACH ARE - COMMON EXCAVATION, GRANULAR BORRROW, TOPSOIL BORROW AND AGG BASE CL-5. NOTE - BITUMINOUS ITEMS FOR RTL - BYPASS CONSTRUCTION ARE INCLUDED IN MAIN SEQ.
- TO BE USED TO TIE IN NEW SH-PI TO EXISTING INSLOPE AND AS NEEDED AROUND X-PIPE CONSTRUCTION AS DIRECTED BY ENGINEER.
- INCLUDES TIME AND EQUIPMENT TO REMOVE EXCESS RECLAIMED MATERIAL AT BEG. AND END OF RECLAIM AREAS AND RXR TRACKS FOR SMOOTH TRANSITION TO EXISTING BITUMINOUS. FINAL SHAPING AND MAINTENANCE OF RECLAIMED ROADWAY INCIDENTAL TO ITEM
- WATER TO BE USED AS DUST CONTROL , AT THE DESCRETION OF THE ENGINEER.
- MATERIAL TO BE USED TO RAISE DIP AREA NORTH OF NORTH X-PIPE. STATION 75+20 TO 77+20
- SHOULDERING CLASS 5 FOR FINISHED 2' GRVL. SHLDR.(CALC. AT 4" DEPTH) AND ALL DR WAYS. AT 7 TONS EACH.
- 2" DEEP BY 4' WIDE MILL AT BEGINNING AND END OF PROJECT AND ALL PAVED ST APPROACHES.
- FULL DEPTH RECLAMATION FROM STA 10+68 TO STA. 48+15 AND STA. 49+15 - 112+80.
- MAINLINE TOP COURSE 2" ( SPWEB440 E ) TOP WEARING SURFACE. MAINLINE BOTTOM COURSE 2" ( SPWEB440 E ) PLACED ON RECLAIMED GRAVEL SURFACE.
- STREET APPROACH / DR WAY BITUMINOUS 2" ( SPWEB440 B) PAVED IN SEPARATE OPERATION THEN MAINLINE PAVING.
- AGGREGATE BEDDING USED FOR X-PIPE INSTALLATION, AS DIRECTED BY THE ENGINEER.
- STA 35+90 , 24" X-PIPE LENGTH MAY CHANGE IF BYPASS IS CONSTRUCTED, INVERTS TO BE INSTALLED AT EXISTING ELEV. REFER TO PLAN SHEET FOR DETAILS.
- STA 75+20 , 58"ARCH PIPE ( INSIDE HIEGHT OF PIPE TO BE 36" ) , INVERTS TO BE AT EXISTING ELEV.
- RIPRAP CLASS II TO BE PLACED AT APRON ENDS OF CROSS PIPES. AREA TO BE COVERD IN RIPRAP TO BE AT THE DESCRETION OF THE ENGINEER.
- MAILBOXES TO BE INSTALLED AT THE EXISTING MAILBOX LOCATION. MAILBOX MATERIALS INCIDENTAL TO INSTALLATION. CONTRACTORS RESPONSIBILITY TO COORDINATE WITH LOCAL POSTAL AUTHORITY.
- " ALL TRAFFIC CONTROL METHODS SHALL CONFORM TO THE MINNESOTA MANUAL ON UNIFORM TRAFFIC CONTROL DEVICES. " DO NOT PASS, PASS WITH CARE, NO CENTER STRIPE AND STOP HERE WHEN FLASHING SIGNS TO BE INPLACE DURING RECLAIM/ PAVING OPERATIONS.
- A DETOUR DOES NOT EXCLUDE THE NEED FOR RAILROAD PROTECTIVE SERVICES WHICH WILL STILL NEED TO BE PRESENT DURING CONSTRUCTION ACTIVITIES IN AND AROUND THE RAILROADS R/W. (DETOUR COST EST. BASED ON A 10 WORKING DAY DETOUR OF COMPRABLE SIZE AND LOCATION.)
- 2 - MESSAGE BOARDS, ONE ON EACH END OF PROJECT WILL BE INSTALLED 7-DAYS PRIOR TO ANY CONSTRUCTION. REFERENCE " TRAFFIC CONTROL QUANTITIES" SECTION OF THIS PLAN FOR DETAILS.
- MATERIAL TO BE ADDED TO EXISTING FLUMES TO MATCH NEW ROAD SURFACE AND TO EXTEND FLUMES TO BOTTOM OF DITCH. ADDITIONAL FLUMES TO BE CONSTRUCTED AS NEEDED AND DIRECTED BY THE ENGINEER. BIT. TACK REQUIRED WILL BE INCIDENTAL. PLACE RIPRAP AND GEOTEXTILE AT FLUME ENDS IF POSSIBLE, AS DIRECTED BY THE ENGINEER.
- INSTALL SILT FENCE SURROUNDING DISTURBED AREAS AROUND CROSS PIPE APRON ENDS.
- EROSION CONTROL BLANKET CAT. 00 TO BE INSTALLED AROUND X-PIPE APRON ENDS AND 1 ROW OF BLANKET ON LOW SIDE OF SUPERS PLACEMENT, SEED AND FERTILIZER INCIDENTAL TO BLANKET. SEED MIXTURE 250 ( RATE - 70 LBS PER ACRE ) AND FERTILIZER TYP 3 ( RATE - 350 LBS PER ACRE )
- PLACEMENT,SEED AND FERTILIZER INCIDENTAL TO RAPID STABILIZATION METHOD 3. SEED MIXTURE 250 ( RATE - 70 LBS PER ACRE ) AND FERTILIZER TYP 3 ( RATE - 350 LBS PER ACRE ) RAPID STABILIZATION METHOD 3 TO BE APPLIED AT A RATE OF 6 M-GAL PER ACRE. ITEM PAID FOR BY THE SQ YD.
- CL YLW SKIPS TO BE APPLIED AS SOON AS POSSIBLE ON EACH LIFT ( MUST BE APPLIED BEFORE CONTRACTOR LEAVES FOR THE DAY), THE CONTRACTOR WILL REMOVE ALL CAL SKIPS PRIOR TO THE FINAL PAINT STRIPPING.
- PERMANENT MARKINGS TO BE IN PLACE WITHIN 72 HOURS OF FINAL MAINLINE PAVING.
- ITEM INCLUDES CONSTRUCTION OF SAFTY EDGE, REFER TO SPECIAL PROVISIONS.
- CONSTRUCTION MAY NOT BEGIN PRIOR TO THE OPENING OF THE CSAH 22 DETOUR SCHEDULED FOR THE SUMMER OF 2013, START DATE MUST BE APPROVED BY ANOKA COUNTY.
- INCLUDES ALL TYPES AND SIZES.
- EXCESS RECLAIMED MATERIAL AT RXR TRACKS TO BE HAULED AND MAY BE USED IN SAG AREA AS BASE MATERIAL . AS DIRECTED BY THE ENGINEER. MATERIAL TO REMAIN WITHIN PROJECT LIMITS OF THIS PROJECT.
- TO BE USED UNDER RIPRAP.
- MAIL BOXES INSIDE RTL / BYPASS CONSTRUCTION AREAS ARE TO BE RELOCATED. REMOVAL AND TEMP INSTALLATION INCLUDED IN ITEM
- DRIVEWAY CULVERTS INSIDE RTL / BYPASS CONST. AREAS TO BE ROMOVED / REPLACED AND MOVED OUT OF INSLOPE AS DIRECTED BY THE ENGINEER.
- 43+50 REMOVE EXISTING RCP ARCH PIPE AND INSTALL NEW ARCH PIPE OUTSIDE NEW RTL INSLOPE.
- TO BE RAISED / ADJUSTED TO NEW FINISHED ELEV.
- INSTALLED IN NEW RTL CONSTRUCTION AREA WHERE YARDS HAVE SPRINKLER SYSTEMS.

NO	DATE	BY	CKD	APPR	REVISION

NAME: P:\13-01-00\CSAH\_13\_(Cedar-CSAH24)\Plan\2\_SEQ.dgn 02/28/2013 8:56:55 AM

I HEREBY CERTIFY THAT THIS PLAN WAS PREPARED BY ME OR UNDER MY DIRECT SUPERVISION AND THAT I AM A DULY LICENSED PROFESSIONAL ENGINEER UNDER THE LAWS OF THE STATE OF MINNESOTA.  
 PRINT NAME: ANDREW WITTER  
 SIGNATURE: *[Signature]*  
 DATE: 3/7/13 LICENSE NO. 42757

DRAWN BY: JF DATE: 1/18/2013  
 DESIGN BY: JF DATE: 1/18/2013  
 CHECKED BY: GA DATE: 1/29/2013

**ANOKA COUNTY HIGHWAY DEPT.**



STATE PROJECT NO. \_\_\_\_\_  
 STATE AID PROJECT NO. \_\_\_\_\_  
 CITY PROJECT NO. \_\_\_\_\_  
 COUNTY PROJECT NO. CP 13-13-13

A RAILROAD PROTECTIVE SERVICES	
LUMP SUM BASED ON 24 TOTAL HRS ESTIMATED	
<b>B REMOVE PIPE CULVERTS</b>	
LOCATION	LIN FT
35+90	71
BYPASS FLINTWOOD	46
RTL FLINTWOOD	102
75+20	70
RTL 236TH	80
BYPASS 236TH	38
RTL CR24	38
<b>TOTAL LIN FT</b>	<b>445</b>

C REMOVE BITUMINOUS PAVEMENT	
LOCATION	SQ YDS
#668	39
#475	22
#280	49
#231	22
#231	32
RXR TRACKS	289
#154	37
#23453	16
MICRO GROUP S.	67
MICRO GROUP N.	42
#23566 PATTERN MOLD S.	46
#23566 PATTERN MOLD N.	43
<b>TOTALS Q YDS</b>	<b>703</b>

D SAW BITUMINOUS PAVEMENT FULL DEPTH	
LOCATION	LIN FT
MAINLINE 10+68	28
MAINLINE 112+80	43
#668	17
#475	12
#280	28
#231	11
#231	15
#154	18
#23453	10
MICRO GROUP S.	39
MICRO GROUP N.	25
#23566 PATTERN MOLD S.	28
#23566 PATTERN MOLD N.	22
<b>TOTAL LIN FT</b>	<b>296</b>

E TOPSOIL BORROW						
MAINLINE	STATION	STATION	LENGTH	END AREA	CU FT	CU YDS
EB/NB	10+68	112+64	10196.0	1.0	10196.00	378
WB/SB	10+68	112+64	10196.0	1.0	10196.00	378
X-PIPE	32+25	36+25				10
X-PIPE	45+25	48+25				10
<b>TOTAL CU YDS</b>						<b>775</b>

F MOTOR GRADER	
LOCATION	HRS
10+68 13+68	4
45+70 - 51+70	8
75+20 - 77+20	8
109+64 - 112+80	4
<b>TOTAL HOURS</b>	<b>24</b>

G AGGREGATE BASE CLASS 5						
MAINLINE	STATION	STATION			CU YDS	TONS
SAG	72+20	74+20			555.6	1000
<b>TOTAL TONS</b>						<b>1000</b>

H AGGREGATE SHLDR CL- 5 ( INC ALL DR WAYS.)						
MAINLINE	STATION	STATION	LENGTH	WIDTH	4" DEPTH	CU YDS
EB/NB	10+68	112+80	10212.0	2.0	0.33	250
WB/SB	10+68	112+80	10212.0	2.0	0.33	250
<b>SUB TOTAL CU YDS</b>						<b>499</b>
<b>SUBTRACT ST. OPENINGS</b>						
				SHLDR W		
HOLLY ST			100.0	2.0	0.33	2
FLINTWOOD			100.0	2.0	0.33	2
UNIVERSITY EXT			100.0	2.0	0.33	2
236TH			100.0	2.0	0.33	2
<b>SUBTRACT ST OPEN</b>						<b>10</b>
<b>SHLDR CU YDS</b>						<b>499</b>
<b>SUBTRACT ST. OPENINGS</b>						<b>10</b>
<b>CU YDS</b>						<b>489</b>
<b>GRVL FACTOR</b>						<b>1.8</b>
<b>TONS</b>						<b>881</b>
<b>ADD GRAVEL FOR ALL DR WAYS</b>						
755						7
FE						7
739						7
668						3
645						7
640						7
633						7
633						7
FE						7
562/229						7
FE						7
541						7
541						7
530						7
475						3
445						7
280						3
231						3
231						3
145						7
154						3
154						7
23216						7
FE						7
23260						7
23311						7
23350						7
23365						7
23417						7
23442						7
23453						3
23462						7
23462						7
23530 S.						3
23530 N.						3
23533						7
23566 S.						3
23566 N.						3
WELD S.						7
FE						7
23633						7
WELD N.						7
23655						7
<b>TOTAL TONS</b>						<b>1138</b>

I MILL BITUMINOUS SURFACE 2" ( JOINTS )				
LOCATION	STATION	LENGTH	WIDTH	SQ YDS
MAINLINE	10+68	28.00	4.0	12
MAINLINE	112+80	43.00	4.0	19
<b>BIT STREETS</b>				
HOLLY ST		51.00	4.0	23
FLINTWOOD		35.00	4.0	16
UNIVERSITY EXT		61.00	4.0	27
236TH		33.00	4.0	15
<b>TOTAL SQ YDS</b>				<b>112</b>

J BITUMINOUS PAVEMENT RECLAMATION				
LOCATION	STATION	STATION		MICRO
MAINLINE	10+68	112+80		29278
<b>TOTAL SQ YDS</b>				<b>29278</b>

K BITUMINOUS MATERIAL FOR TACK				
LOCATION		SQ YDS	GAL/SQYD	GAL
<b>BASE AREA ( MICRO )</b>				
10+68 - 112+80		34132.22	0.05	1707
<b>BIT ST APP</b>				
HOLLY		195.70	0.05	10
FLINTWOOD		51.82	0.05	3
UNIVERSITY EXT		225.78	0.05	11
236TH		105.90	0.05	5
<b>NEW RTL / BYPASS</b>				
HOLLY ST BYPASS		826.66	0.05	41
FLINTWOOD BYPASS		826.66	0.05	41
FLINTWOOD RTL		640.00	0.05	32
UNIVERSITY BYPASS		826.66	0.05	41
236TH RTL		640.00	0.05	32
236TH BYPASS		826.66	0.05	41
CR 24 RTL		640.00	0.05	32
<b>TOTAL GAL</b>				<b>1997</b>

L TYPE SP 12.5 WEARING COURSE MIX ( SPWEB440 E )			
MAINLINE ( TOP SURFACE ) EX-BIT MAT MICROSTATION AREA	SQ YDS		
STA 10+68 - 112+80	32996		
<b>MAINLINE ( BOTTOM SURFACE ) EX-BIT MAT MICROSTATION AREA + 6"</b>			
STA 10+68 - 112+80	34132		
<b>NEW RTL / BYPASS ( INCLUDES BOTH LIFTS )</b>			
HOLLY ST BYPASS	1653		
FLINTWOOD BYPASS	1653		
FLINTWOOD RTL	1280		
UNIVERSITY BYPASS	1653		
236TH RTL	1280		
236TH BYPASS	1653		
CR 24 RTL	1280		
<b>TOTAL SQ YDS</b>		<b>77582</b>	
<b>( SQ YDS X 2" IN X 115LB ) / 2000</b>		<b>TOTAL TONS</b>	<b>8922</b>

NO	DATE	BY	CKD	APPR	REVISION

I HEREBY CERTIFY THAT THIS PLAN WAS PREPARED BY ME OR UNDER MY DIRECT SUPERVISION AND THAT I AM A DULY LICENSED PROFESSIONAL ENGINEER UNDER THE LAWS OF THE STATE OF MINNESOTA.

PRINT NAME: ANDREW WITTEK  
 SIGNATURE: *[Signature]*  
 DATE: 3/7/13 LICENSE NO. 42757

DRAWN BY: JF DATE: 3/18/2013  
 DESIGN BY: JF DATE: 3/18/2013  
 CHECKED BY: GA DATE: 1/29/2013



**ANOKA COUNTY**  
**HIGHWAY DEPT.**

STATE PROJECT NO. \_\_\_\_\_  
 STATE AID PROJECT NO. \_\_\_\_\_  
 CITY PROJECT NO. \_\_\_\_\_  
 COUNTY PROJECT NO. CP 13-13-13

M TYPE SP 12.5 WEARING COURSE MIX ( SPWEB440 B )	
STREETS	SQ.YDS.
HOLLY ST	196
FLINTWOOD	52
UNIVERSITY	226
236TH	106
BIT ENTRANCES	
6+68	39
4+75	22
280	49
231	22
231	32
154	37
23453	16
MICRO S.	67
MICRON.	42
23566 S.	46
23566 N.	43
(BASED ON 3" DEPTH VAR. ST APP.)	TOTAL SQ YDS 993
(SQ YDS X 3" IN X 115LB ) / 2000	TOTAL TONS 171

N AGGREGATE BEDDING					
STA	LENGTH	WIDTH	DEPTH 8"	CU FT	CU YDS LV
35+90	84	4	0.67	225.12	8
75+20	72	6	0.67	289.44	11
TOTAL CU YDS					19

O 15" CS PIPE CULVERT		
LOC.		LIN FT
EB	BYPASS FLINTWOOD	46
WB	RTL FLINTWOOD	30
NB	RTL 236TH	92
SB	BYPASS 236TH	38
NB	RTL CR 24	38
TOTAL LIN FT		244

P 24" RC PIPE APRON	
STA	EACH
35+90	2

Q 22" SPAN RC PIPE ARCH CULV. CL IIA		
LOC.	LIN FT	
NB	RTL 236TH	36

R 58" RC ARCH PIPE CULVERT DES 3006 CL III	
STA	LIN FT
75+20	56

S 22" SPAN RC PIPE ARCH APRON		
LOC.		EACH
NB	RTL 236TH	2

T 58" RC ARCH PIPE APRON	
STA	EACH
75+20	2

U 24" RC PIPE CULVERT DES 3006 CL III	
STA	LIN FT
35+90	72

V 15" GS SAFETY APRON AND GRATE DES 3148		
LOC.		
EB	BYPASS FLINTWOOD	2
WB	RTL FLINTWOOD	2
NB	RTL 236TH	4
SB	BYPASS 236TH	2
NB	RTL CR 24	2
TOTAL		12

W RECONSTRUCT DRAINAGE STRUCTURE		
LOC.	LIN FT	
NB	RTL 236TH	11

X CASTING ASSEMBLY		
	LOC.	EACH
NB	RTL 236TH	3
NB	RTL CR 24	2
TOTAL		5

Y ADJUST FRAME RING AND CASTING		
	LOC.	EACH
NB	RTL 236TH	1
NB	RTL CR 24	2
TOTAL		3

Z RANDOM RIPRAP CLASS II					
	LENGTH	WIDTH	DEPTH	CU FT	CU YDS
35+90	10	10	0.67	67	2
35+90	10	10	0.67	67	2
75+20	16	12	0.67	128.64	5
75+20	16	12	0.67	128.64	5
TOTAL CU YDS					14

AA GEOTEXTILE FILTER TYPE IV					
	LENGTH	WIDTH		SQ FT	SQ YDS
35+90	10	10		100	11
35+90	10	10		100	11
75+20	16	12		192	21
75+20	16	12		192	21
TOTAL SQ YDS					65

BB INSTALL MAIL BOX SUPPORT				
ADDRESS	DR LOC	BOX LOC	QTY	
#755	LT	LT	1	
#739	LT	LT	1	
#668	RT	RT	1	
#645	LT	LT	1	
#640	RT	RT	1	
#633	LT	LT	1	
#633	LT		0	
#562/229	RT	RT	1	
#541	LT	LT	1	
#541	LT		0	
#530	RT	RT	1	
#475	LT	LT	1	
#445	LT	LT	1	
#280	RT	RT	1	
#231	LT	LT	1	
#231	LT		0	
#145	LT	LT	1	
#154	RT	RT	1	
#154	RT	RT	1	
#23216	LT	LT	1	
#23260	LT	LT	1	
#23311	RT	RT	1	
#23350	LT	LT	1	
#23365	RT	RT	1	
#23417	RT	RT	1	
#23442	LT	LT	1	
#23453	RT	RT	1	
#23462	LT		0	
#23462	LT	LT	1	
#23530	LT		0	
#23530	LT		0	
#23533	RT	RT	1	
#23566	LT		0	
#23566	LT	LT	1	
TRAILER REP	LT	RT	1	
#23633	RT	RT	1	
TRAILER REP	LT		0	
#23655	RT	RT	1	
TOTAL				30

CC PORTABLE CHANGEABLE MESSAGE BOARD		
2 UNITS @ 7 DAYS EACH = TOTAL UNIT DAYS		14

DD BITUMINOUS LINED FLUME				
LOCATION	WIDTH	LENGTH	SQ FT	SQ YD
236TH	8	15	120.0	13
TOTAL SQ YDS				13

EE SILT FENCE TYPE MACHINE SLICED		
LOC.		LIN FT
EB STA 35+90		80
WB STA 35+90		80
NB STA 75+20		80
SB STA 75+20		80
HOLLY ST BYPASS		620
FLINTWOOD BYPASS		620
FLINTWOOD RTL		480
UNIV. BYPASS		620
236TH RTL		480
236TH BYPASS		620
CR 24 RTL		480
TOTAL LIN FT		4240

FF CULVERT PROTECTION		
LOC.		EACH
HOLLY ST BYPASS		1
FLINTWOOD BYPASS		1
FLINTWOOD RTL		2
UNIV. BYPASS		0
236TH RTL		1
236TH BYPASS		0
CR 24 RTL		2
TOTAL		7

GG EROSION CONTROL BLANKET CAT 00				
LOCATION	WIDTH	LENGTHX2	SQ FT	SQ YD
X-PIPE LOCATIONS				
LEB STA 41+90	16	16	256.0	28
LWB STA 48+25	16	16	256.0	28
LWB STA 49+00	16	16	256.0	28
LWB STA 56+00	16	16	256.0	28
LOC.				
HOLLY ST BYPASS	620	16	9920	1102
FLINTWOOD BYPASS	620	16	9920	1102
FLINTWOOD RTL	480	16	7680	853
UNIV. BYPASS	620	16	9920	1102
236TH RTL	480	16	7680	853
236TH BYPASS	620	16	9920	1102
CR 24 RTL	480	16	7680	853
TOTAL SQ YDS				7083

HH RAPID STABILIZATION METHOD 3			
LOCATION	LENGTH	WIDTH	SQ YD
STA 10+68 - 112+64	10196	6	6797
STA 10+68 - 112+64	10196	6	6797
TOTAL SQ YDS			13595
ACRE			3
RATE 6 MGAL/ACRE			6
TOTAL M GAL			17

II REMOVABLE PREFORMED PLASTIC MARKINGS				
BEG. STA.	END STA.	LENGTH	DIV BY 50'	X 2'
BASE 10+68	112+80	10212	204.2	408
WEAR 10+68	112+80	10212	204.2	408
TOTAL LIN FT				817

NO	DATE	BY	CKD	APPR	REVISION

I HEREBY CERTIFY THAT THIS PLAN WAS PREPARED BY ME OR UNDER MY DIRECT SUPERVISION AND THAT I AM A DULY LICENSED PROFESSIONAL ENGINEER UNDER THE LAWS OF THE STATE OF MINNESOTA.  
 PRINT NAME: ANDREW WITTER  
 SIGNATURE: *[Signature]*  
 DATE: 3/7/13 LICENSE NO. 42757

DRAWN BY: JF DATE: 1/18/2013  
 DESIGN BY: JF DATE: 1/18/2013  
 CHECKED BY: GA DATE: 1/29/2013

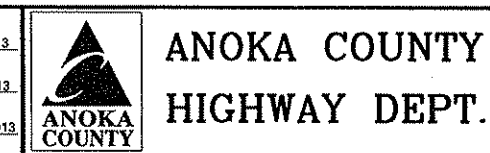

STATE PROJECT NO. \_\_\_\_\_  
 STATE AID PROJECT NO. \_\_\_\_\_  
 CITY PROJECT NO. \_\_\_\_\_  
 COUNTY PROJECT NO. CP 13-13-13

ITEMS INCLUDED IN RTL / BYPASS BY THE EACH ARE - COMMON EXCAVATION, GRANULAR BORROW, TOPSOIL BORROW AND AGG. BASE CLASS 5. OTHER ITEMS ARE LISTED FOR INFORMATIONAL PURPOSES AND ARE INCLUDED IN THE MAIN SEQ.

STREET	STA.	DIR.	RTL / BYPASS	WIDTH	LENGTH	REMOVE PIPE CULVERTS 2104.501 (LIN FT)	COMMON EXCAVATION 2105.501 (CU YD)	GRANULAR BORROW (CV) 2105.521 (CU YD)	TOPSOIL BORROW (LV) 2105.525 (CU YD)	AGG BASE CLASS 5 (CV) 2211.501 (TON)	15" CS PIPE CULVERT 2501.511 (LIN FT)	22" SPAN RC PIPE- ARCH CULV CL IIA 2501.521 (LIN FT)	22" SPAN RC PIPE ARCH APRON 2501.525 (EACH)	15" GS SAFETY APRON & GRATE DES 3148 2501.567 (EACH)	RECONST. DRAINAGE STRUCTURE 2506.503 (LIN FT)	CASTING ASSEMBLY 2506.516 (EACH)	ADJUST FRAME RING AND CASTING 2506.522 (EACH)	SILT FENCE MACHINE SLICED 2573.502 (LIN FT)	CULVERT PROTECTION 2573.602 (EACH)	SODDING TYPE SALT RESISTANT 2575.505 (SQ YD)	EROSION CONTROL BLANKET CAT 00 2575.523 (SQ YD)
HOLLY ST	33+99 - 40+19	WB	BYPASS	12	620.0	0	375	562	121	298	0	0	0	0	0	0	0	620	1	0	1102
FLINTWOOD	39+96 - 46+16	EB	BYPASS	12	620.0	46	375	562	121	298	46	0	0	2	0	0	0	620	1	0	1102
FLINTWOOD	43+74 - 48+54	WB	RTL	12	480.0	102	155	262	94	230	30	60	2	2	0	0	0	480	2	0	853
UNIVERSITY	60+83 - 67+03	SB	BYPASS	12	620.0	0	200	562	121	298	0	0	0	0	0	0	0	620	0	0	1102
236 TH	101+01 - 105+81	NB	RTL	12	480.0	80	290	435	94	230	38	36	2	2	11	3	1	480	1	0	853
236 TH	103+43 - 109+63	SB	BYPASS	12	620.0	38	200	562	121	298	38	0	0	2	0	0	0	620	0	533	427
CR 24	108+00 - 112+80	NB	RTL	12	480.0	38	155	262	94	230	38	0	0	2	0	2	2	480	2	1066	0

STANDARD DETAIL PLATES

PLATE NO.	TITLE
3000	REINFORCED CONCRETE PIPE
3014	REINFORCED CONCRETE PIPE ARCH
3022	PRECAST CONCRETE SAFETY APRON
3040	CORRUGATED METAL PIPE CULVERT
3100	CONCRETE APRON FOR REINFORCED CONCRETE PIPE
3110	CONCRETE APRON FOR REINFORCED CONCRETE ARCH PIPE
3128	METAL SAFETY APRON AND GRATE
3133	RIPRAP AT RCP OUTLETS
4005	MANHOLE OR CATCH BASIN
4006	MANHOLE OR CATCH BASIN PRECAST G & H
4026	CONCRETE ENCASED CONCRETE ADJUSTING RINGS
4101	RING CASTING FOR MANHOLE OR CATCH BASIN
8000	STANDARD BARRICADES
9350	MAILBOX SUPPORT ( SWING AWAY TYPE )

NO	DATE	BY	CKD	APPR	REVISION

NAME: P:\113-01\CSAH\_13 (Cedar-CSAH24)\Plan\4 RTL BYPASS TABS.dgn 02/22/2013 8:20:06 AM

I HEREBY CERTIFY THAT THIS PLAN WAS PREPARED BY ME OR UNDER MY DIRECT SUPERVISION AND THAT I AM A DULY LICENSED PROFESSIONAL ENGINEER UNDER THE LAWS OF THE STATE OF MINNESOTA.

PRINT NAME: ANDREW WITTER

SIGNATURE: *[Signature]*

DATE: 3/7/13 LICENSE NO. 42757

DRAWN BY JF DATE 1/18/2013

DESIGN BY JF DATE 1/18/2013

CHECKED BY GA DATE 1/29/2013

**ANOKA COUNTY**  
**HIGHWAY DEPT.**



STATE PROJECT NO. \_\_\_\_\_

STATE AID PROJECT NO. \_\_\_\_\_

CITY PROJECT NO. \_\_\_\_\_

COUNTY PROJECT NO. CP 13-13-13

AVR. 2' DEPTH CALC.  
 FLINTWOOD RTL, UNIVERSITY BYPASS, 236TH BYPASS, CR 24 RTL

NEW 12' RTL.

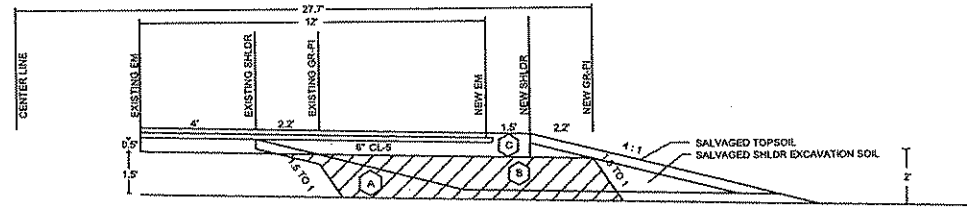

- (A) COMMON EXCAVATION  
8.71 SQ FT
- (B) GRANULAR BORROW (HATCHED AREA)  
14.74 SQ FT
- (C) CLASS 5  
7.20 SQ FT

NEW 12' BYPASS

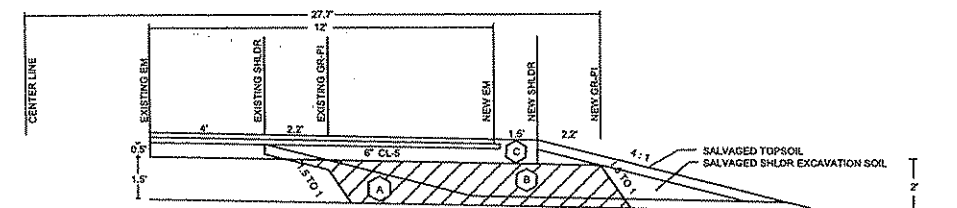

- (A) COMMON EXCAVATION  
8.71 SQ FT
- (B) GRANULAR BORROW (HATCHED AREA)  
14.74 SQ FT
- (C) CLASS 5  
7.20 SQ FT

CU YDS PER 100'

- (A) COMMON EXCAVATION  
 $8.71 \text{ SQ FT} \times 100' = 871 \text{ CU FT} / 27 = 32.25 \text{ CU YDS}$
- (B) GRANULAR BORROW  
 $14.74 \text{ SQ FT} \times 100' = 1474 \text{ CU FT} / 27 = 54.59 \text{ CU YDS}$
- (C) BASE CLASS 5  
 $7.20 \text{ SQ FT} \times 100' = 720 \text{ CU FT} / 27 = 26.66 \text{ CU YDS}$

CU YDS PER 100'

- (A) COMMON EXCAVATION  
 $8.71 \text{ SQ FT} \times 100' = 871 \text{ CU FT} / 27 = 32.25 \text{ CU YDS}$
- (B) GRANULAR BORROW  
 $14.74 \text{ SQ FT} \times 100' = 1474 \text{ CU FT} / 27 = 54.59 \text{ CU YDS}$
- (C) BASE CLASS 5  
 $7.20 \text{ SQ FT} \times 100' = 720 \text{ CU FT} / 27 = 26.66 \text{ CU YDS}$

SUMMARY  
480' RTL.

- (A) COMMON EXCAVATION  
 $32.25 \text{ CU YDS (PER 100')} \times 4.80 \text{ RTL.} = 154.80 \text{ CU YDS}$
- (B) GRANULAR BORROW  
 $54.59 \text{ CU YDS (PER 100')} \times 4.80 \text{ RTL.} = 262.03 \text{ CU YDS}$
- (C) BASE CLASS 5  
 $26.66 \text{ CU YDS (PER 100')} \times 4.80 \text{ BYPASS} = 127.96 \text{ CU YDS} \times 1.8 = 230.34 \text{ TONS (CV)}$

SUMMARY  
620' BYPASS

- (A) COMMON EXCAVATION  
 $32.25 \text{ CU YDS (PER 100')} \times 6.2 \text{ BYPASS} = 199.95 \text{ CU YDS}$
- (B) GRANULAR BORROW  
 $54.59 \text{ CU YDS (PER 100')} \times 6.20 \text{ BYPASS} = 338.45 \text{ CU YDS}$
- (C) BASE CLASS 5  
 $26.66 \text{ CU YDS (PER 100')} \times 6.20 \text{ BYPASS} = 165.29 \text{ CU YDS} \times 1.8 = 297.52 \text{ TONS (CV)}$

RTL / BYPASS LAYOUT

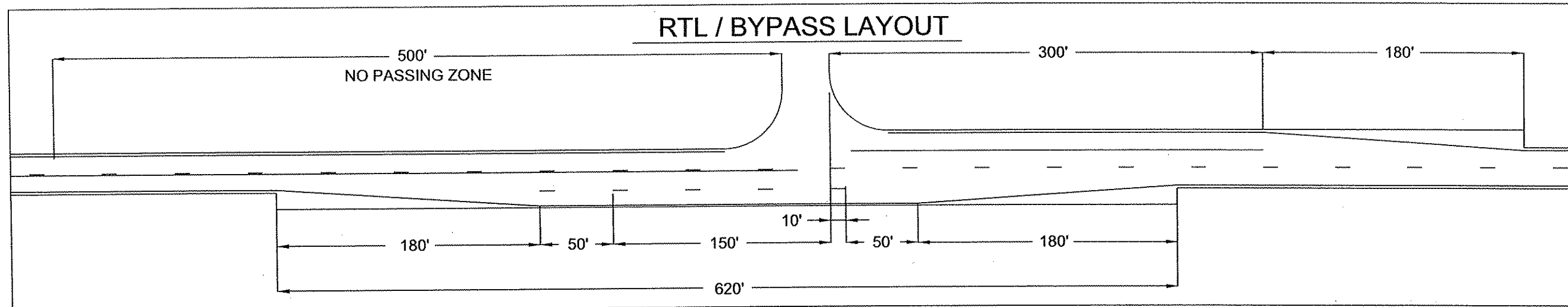

NO	DATE	BY	CKD	APPR	REVISION

NAME: P:\13-01-00\CSAH\_13 (Cedar-CSAH24)\Plan\RTL BYPASS DETAILS.dgn 02/22/2013 8:22:21 AM

I HEREBY CERTIFY THAT THIS PLAN WAS PREPARED BY ME OR UNDER MY DIRECT SUPERVISION AND THAT I AM A DULY LICENSED PROFESSIONAL ENGINEER UNDER THE LAWS OF THE STATE OF MINNESOTA.  
 PRINT NAME: ANDREW WITTER  
 SIGNATURE: *Andrew Witter*  
 DATE: 3/7/13 LICENSE NO. 42757

DRAWN BY: JF DATE: 1/18/2013  
 DESIGN BY: JF DATE: 1/18/2013  
 CHECKED BY: GA DATE: 1/29/2013

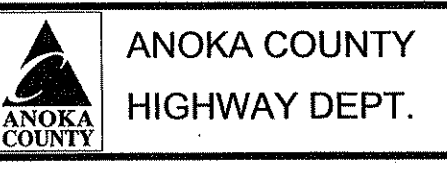

STATE PROJECT NO. \_\_\_\_\_  
 STATE AID PROJECT NO. \_\_\_\_\_  
 CITY PROJECT NO. \_\_\_\_\_  
 COUNTY PROJECT NO. CP 13-13-13

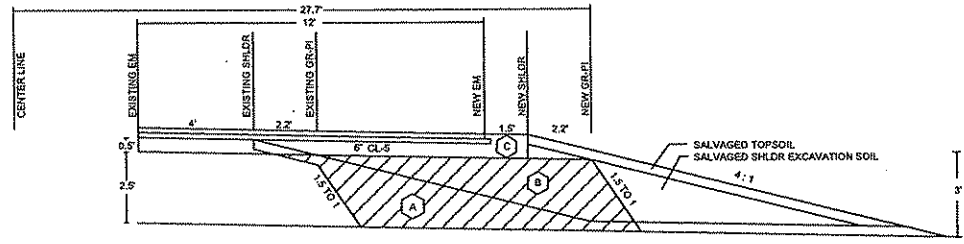
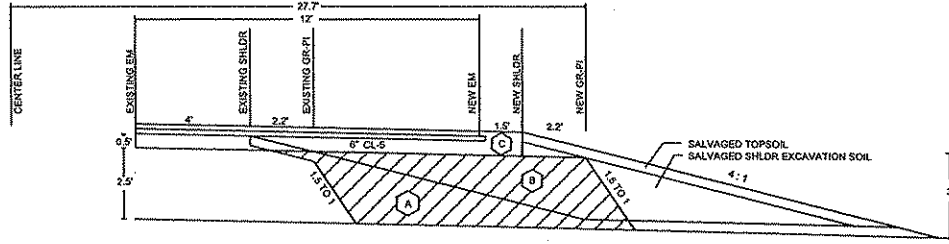

AVR. 3' DEPTH CALC.  
 HOLLY BYPASS, FLINTWOOD BYPASS, 236TH RTL

NEW 12' RTL.	NEW 12' BYPASS
 <p> <b>A</b> COMMON EXCAVATION                  16.34 SQ FT  <b>B</b> GRANULAR BORROW                  (HATCHED AREA)                  24.47 SQ FT  <b>C</b> CLASS 5                  7.20 SQ FT             </p>	 <p> <b>A</b> COMMON EXCAVATION                  16.34 SQ FT  <b>B</b> GRANULAR BORROW                  (HATCHED AREA)                  24.47 SQ FT  <b>C</b> CLASS 5                  7.20 SQ FT             </p>
<p><b>CU YDS PER 100'</b></p> <p> <b>A</b> COMMON EXCAVATION  <math>16.34 \text{ SQ FT} \times 100' = 1634 \text{ CU FT} / 27 = 60.51 \text{ CU YDS}</math> </p> <p> <b>B</b> GRANULAR BORROW  <math>24.47 \text{ SQ FT} \times 100' = 2447 \text{ CU FT} / 27 = 90.62 \text{ CU YDS}</math> </p> <p> <b>C</b> BASE CLASS 5  <math>7.20 \text{ SQ FT} \times 100' = 720 \text{ CU FT} / 27 = 26.66 \text{ CU YDS}</math> </p>	<p><b>CU YDS PER 100'</b></p> <p> <b>A</b> COMMON EXCAVATION  <math>16.34 \text{ SQ FT} \times 100' = 1634 \text{ CU FT} / 27 = 60.51 \text{ CU YDS}</math> </p> <p> <b>B</b> GRANULAR BORROW  <math>24.47 \text{ SQ FT} \times 100' = 2447 \text{ CU FT} / 27 = 90.62 \text{ CU YDS}</math> </p> <p> <b>C</b> BASE CLASS 5  <math>7.20 \text{ SQ FT} \times 100' = 720 \text{ CU FT} / 27 = 26.66 \text{ CU YDS}</math> </p>
<p><b>SUMMARY 480' RTL.</b></p> <p> <b>A</b> COMMON EXCAVATION  <math>60.51 \text{ CU YDS (PER 100')} \times 4.80 \text{ RTL.} = 290.44 \text{ CU YDS}</math> </p> <p> <b>B</b> GRANULAR BORROW  <math>90.62 \text{ CU YDS (PER 100')} \times 4.80 \text{ RTL.} = 434.97 \text{ CU YDS}</math> </p> <p> <b>C</b> BASE CLASS 5  <math>26.66 \text{ CU YDS (PER 100')} \times 4.80 \text{ BYPASS} = 127.96 \text{ CU YDS} \times 1.8 = 230.34 \text{ TONS (CV)}</math> </p>	<p><b>SUMMARY 620' BYPASS</b></p> <p> <b>A</b> COMMON EXCAVATION  <math>60.51 \text{ CU YDS (PER 100')} \times 6.20 \text{ BYPASS} = 375.16 \text{ CU YDS}</math> </p> <p> <b>B</b> GRANULAR BORROW  <math>90.62 \text{ CU YDS (PER 100')} \times 6.20 \text{ BYPASS} = 561.84 \text{ CU YDS}</math> </p> <p> <b>C</b> BASE CLASS 5  <math>26.66 \text{ CU YDS (PER 100')} \times 6.20 \text{ BYPASS} = 165.29 \text{ CU YDS} \times 1.8 = 297.52 \text{ TONS (CV)}</math> </p>

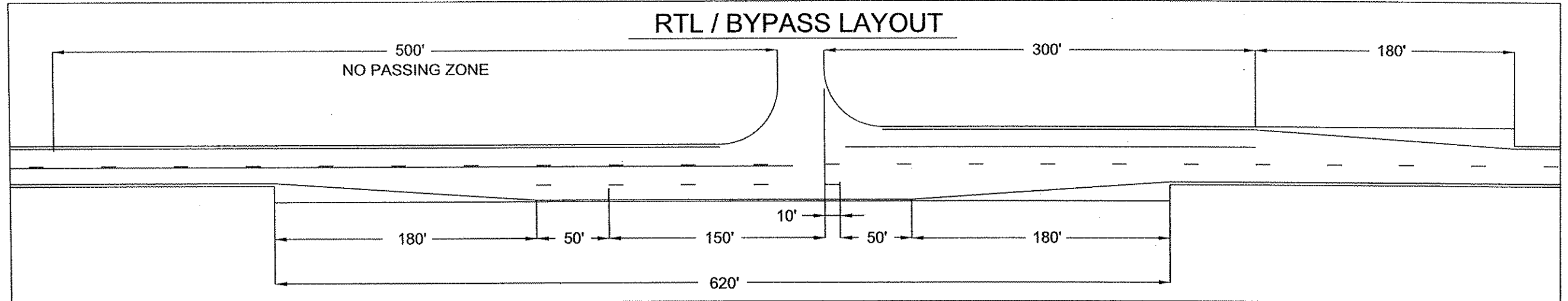

NO	DATE	BY	CKD	APPR	REVISION

NAME: P:\13-01-00\CSAH\_13\_(Cedar-CSAH24)\Plan\5 RTL BYPASS DETAILS.dgn 02/22/2013 8:11:12 AM

I HEREBY CERTIFY THAT THIS PLAN WAS PREPARED BY ME OR UNDER MY DIRECT SUPERVISION AND THAT I AM A DULY LICENSED PROFESSIONAL ENGINEER UNDER THE LAWS OF THE STATE OF MINNESOTA.

PRINT NAME: ANDREW WITTER  
 SIGNATURE: *[Signature]*  
 DATE: 3/7/13 LICENSE NO. 42757

DRAWN BY: JF DATE: 1/18/2013  
 DESIGN BY: JF DATE: 1/18/2013  
 CHECKED BY: GA DATE: 1/29/2013



STATE PROJECT NO. \_\_\_\_\_  
 STATE AID PROJECT NO. \_\_\_\_\_  
 CITY PROJECT NO. \_\_\_\_\_  
 COUNTY PROJECT NO. CP 13-13-13

GRAVEL DR. WAYS AND FEILD ENT.

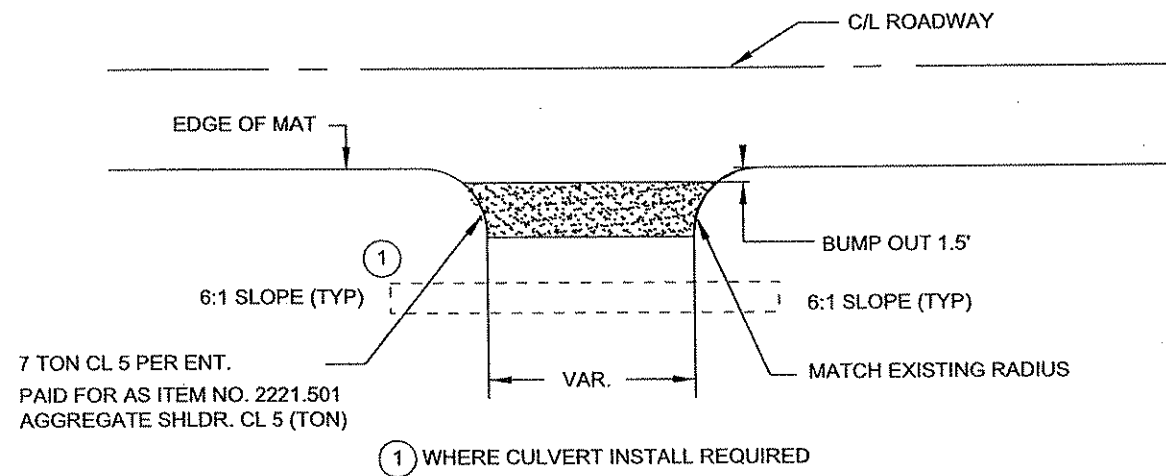

PAVED DR. WAYS

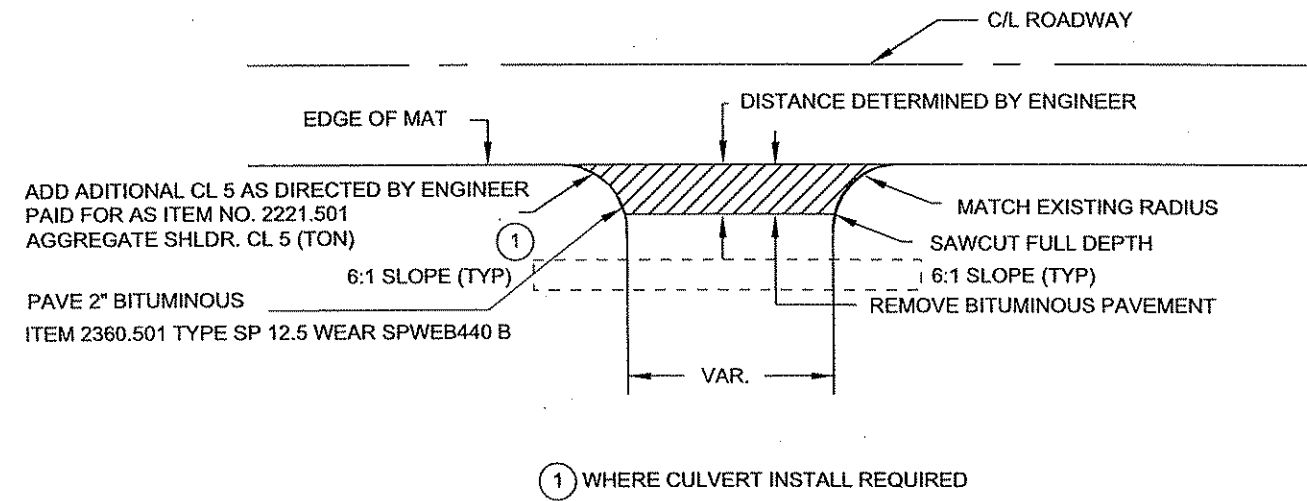

PAVED STREET APPROACHES

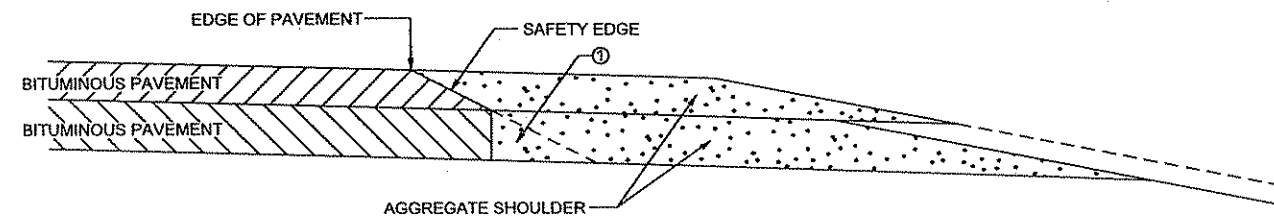
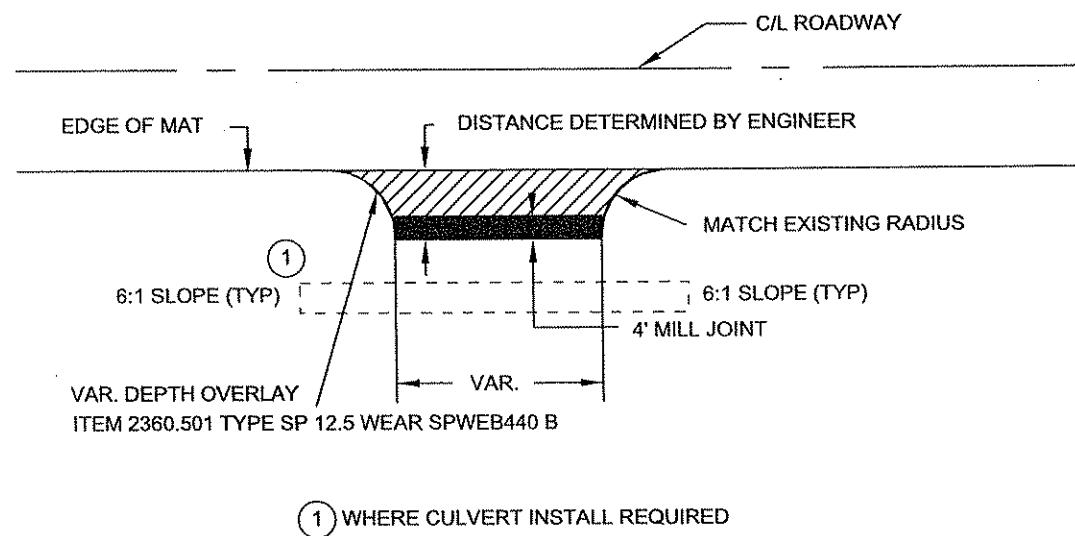

**FIGURE B**  
**BITUMINOUS PAVEMENT**  
 SAFETY EDGE TO BE USED IN ALL NON-CURB AREAS ON SHOULDER.  
 ① OPTIONAL DESIGN EXTENDS SAFETY EDGE DEEPER THAN 6" AND WIDER THAN 10.5". SEE SPECIAL PROVISIONS.

NO	DATE	BY	CHKD	APPR	REVISION

NAME: P:\13-01-00\CSAH\_13\_(Cedar-CSAH24)\Plan6\_CONST.DETAILS.dgn 02/22/2013 8:52:54 AM

I HEREBY CERTIFY THAT THIS PLAN WAS PREPARED BY ME OR UNDER MY DIRECT SUPERVISION AND THAT I AM A DULY LICENSED PROFESSIONAL ENGINEER UNDER THE LAWS OF THE STATE OF MINNESOTA.  
 PRINT NAME: ANDREW WITTER  
 SIGNATURE: *[Signature]*  
 DATE: 3/7/13 LICENSE NO. 42787

DRAWN BY JF DATE 1/18/2013  
 DESIGN BY JF DATE 1/18/2013  
 CHECKED BY GA DATE 1/29/2013



**ANOKA COUNTY**  
**HIGHWAY DEPT.**

STATE PROJECT NO. \_\_\_\_\_  
 STATE AID PROJECT NO. \_\_\_\_\_  
 CITY PROJECT NO. \_\_\_\_\_  
 COUNTY PROJECT NO. CP 13-13-13

CONSTRUCTION DETAILS  
 Sheet 8 of 27 Sheets

PAVED DRIVEWAYS

DETAILS

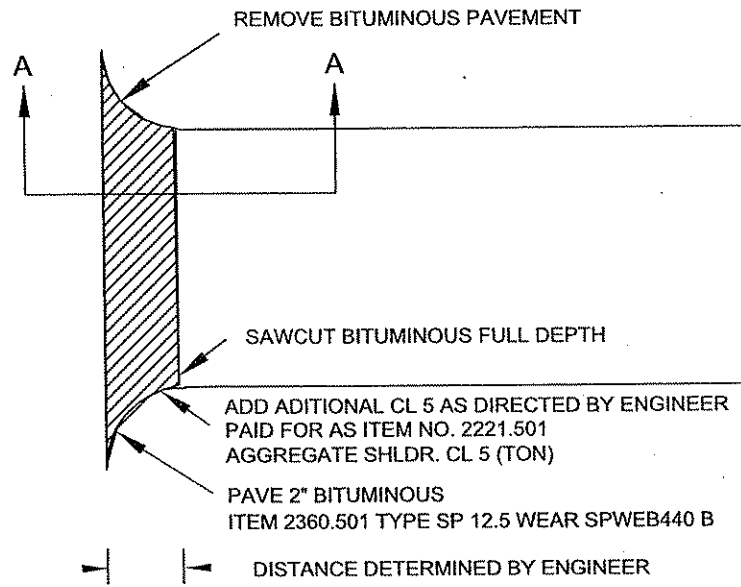

PAVED DRIVEWAY DETAILS A - A

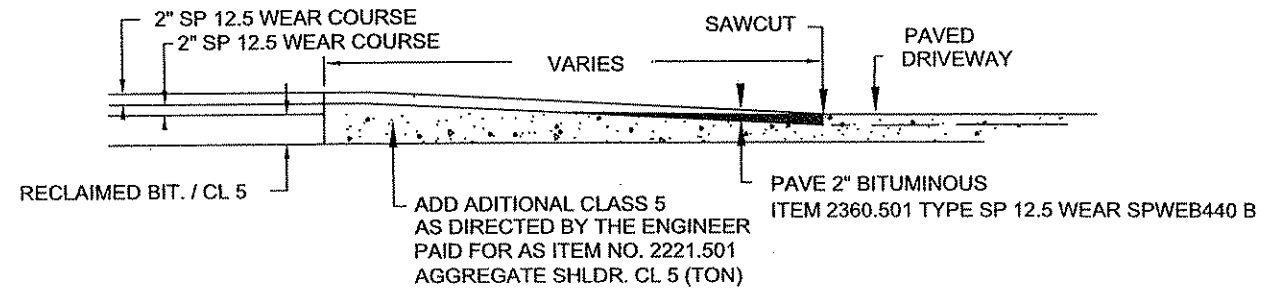

PAVED STREET APPROACH

JOINT DETAILS

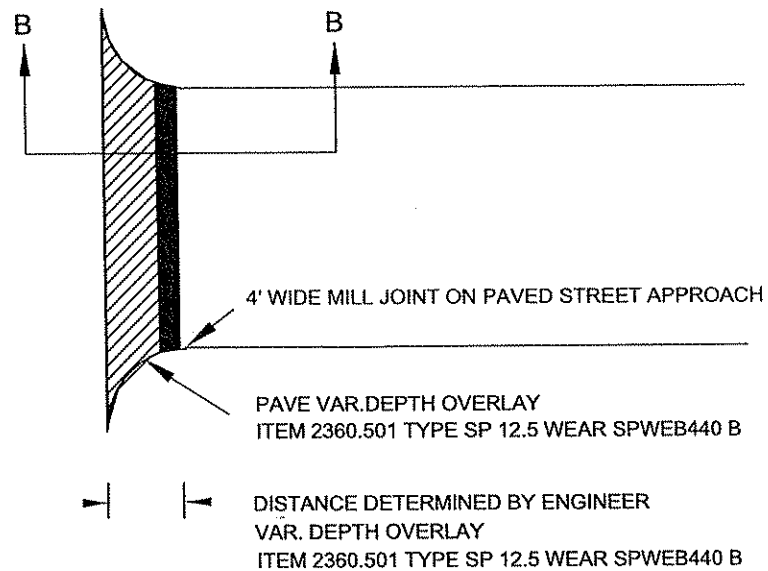

PAVED STREET APPROACH JOINT DETAILS B - B

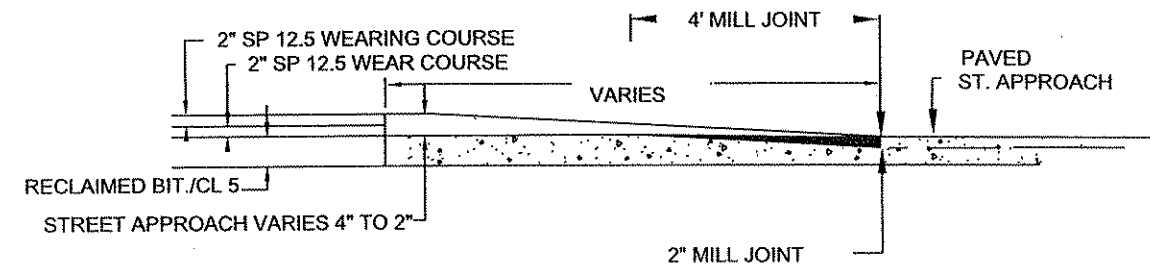

NO	DATE	BY	CHKD	APPR	REVISION

NAME: P:\13-01-00\CSAH\_13\_(Cedar-CSAH24)\Plan6\_CONST.DETAILS.dgn 02/22/2013 8:38:13 AM

I HEREBY CERTIFY THAT THIS PLAN WAS PREPARED BY ME OR UNDER MY DIRECT SUPERVISION AND THAT I AM A DULY LICENSED PROFESSIONAL ENGINEER UNDER THE LAWS OF THE STATE OF MINNESOTA.

PRINT NAME: ANDREW WITTE

SIGNATURE: *Andrew Witte*

DATE: 3/21/13 LICENSE NO. 42757

DRAWN BY JE DATE 1/18/2013

DESIGN BY JE DATE 1/18/2013

CHECKED BY GA DATE 1/29/2013

**ANOKA COUNTY**  
**HIGHWAY DEPT.**

STATE PROJECT NO. \_\_\_\_\_

STATE AID PROJECT NO. \_\_\_\_\_

CITY PROJECT NO. \_\_\_\_\_

COUNTY PROJECT NO. CP 13-13-13

# EXISTING TYPICALS

STA 10+68 - 31+60  
 STA 37+52 - 58+69  
 STA 64+43 - 112+80

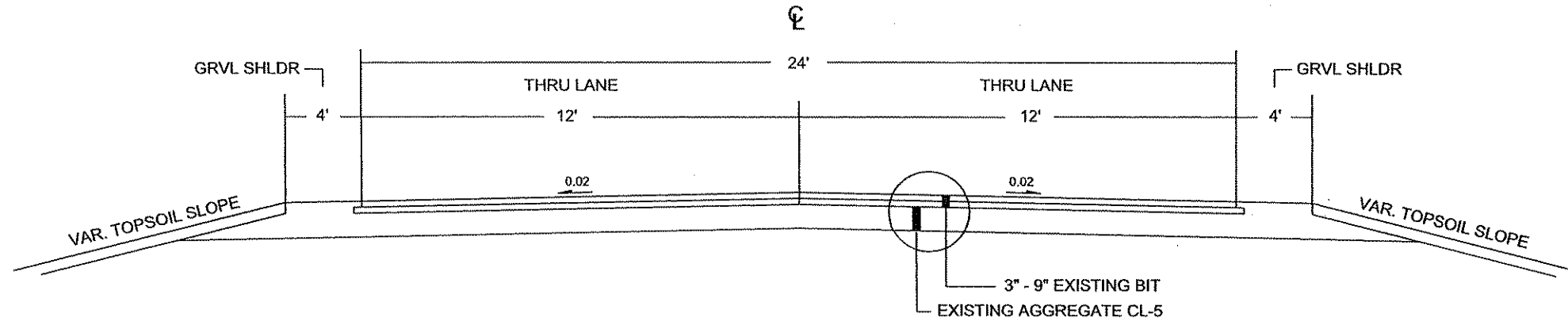

STA 31+60 - 37+52  
 STA 58+69 - 64+43

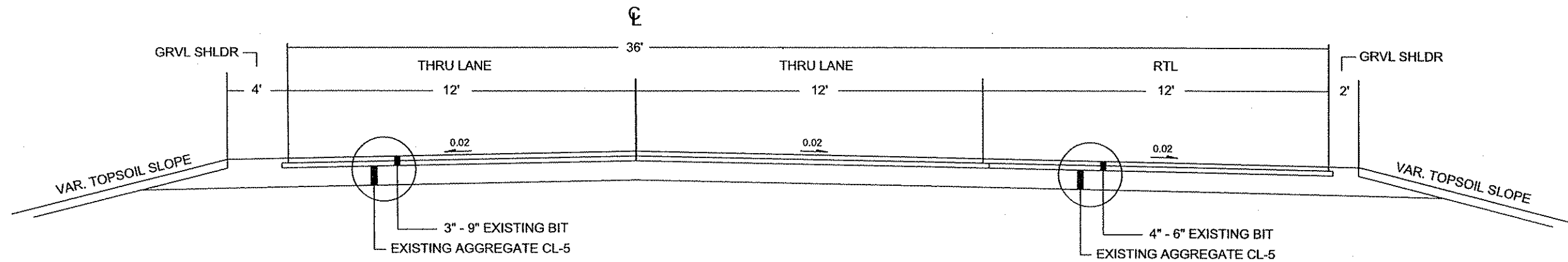

**GENERAL NOTES:**

- ALL CROSS SLOPES ARE APPROXIMATE
- UNLESS OTHERWISE SPECIFIED, THE CLASS 5 CROSS SLOPES SHALL BE THE SAME AS THE FINISHED SURFACE OF THE MAINLINE.

NO	DATE	BY	CKD	APPR	REVISION

NAME: P:\13-01-00\CSAH\_13 (Cedar-CSAH24)\Plan\TYPICALS.dgn 02/22/2013 8:42:09 AM

I HEREBY CERTIFY THAT THIS PLAN WAS PREPARED BY ME OR UNDER MY DIRECT SUPERVISION AND THAT I AM A DULY LICENSED PROFESSIONAL ENGINEER UNDER THE LAWS OF THE STATE OF MINNESOTA.  
 PRINT NAME: ANDREW WITTER  
 SIGNATURE: *Andrew Witter*  
 DATE: 3/7/13 LICENSE NO. 42757

DRAWN BY: JF DATE: 1/18/2013  
 DESIGN BY: JF DATE: 1/18/2013  
 CHECKED BY: GA DATE: 1/29/2013



**ANOKA COUNTY  
 HIGHWAY DEPT.**

STATE PROJECT NO. \_\_\_\_\_  
 STATE AID PROJECT NO. \_\_\_\_\_  
 CITY PROJECT NO. \_\_\_\_\_  
 COUNTY PROJECT NO. CP 13-13-13

TYPICALS  
 Sheet 10 of 27 Sheets

# PROPOSED TYPICALS

STA 10+68 - 31+60  
 STA 37+52 - 58+69  
 STA 64+43 - 112+80

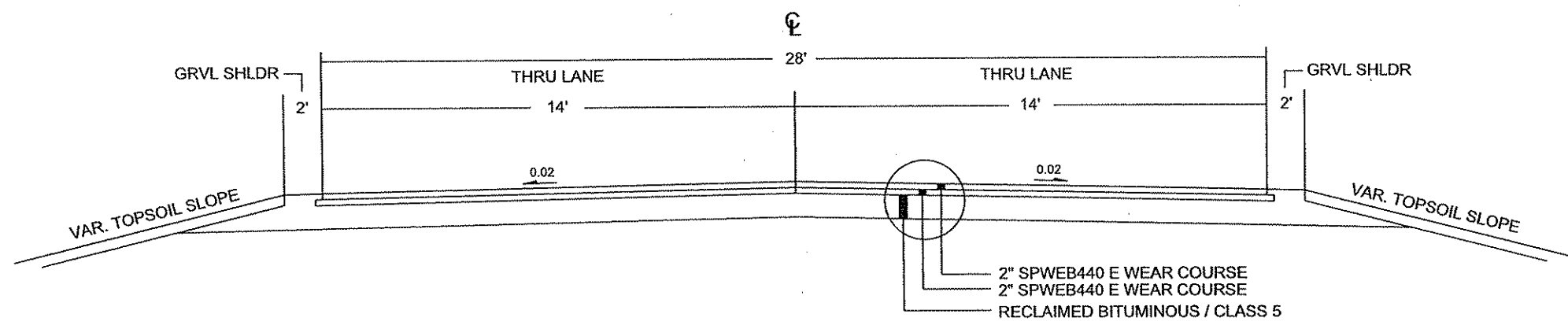

STA 31+60 - 37+52  
 STA 58+69 - 64+43

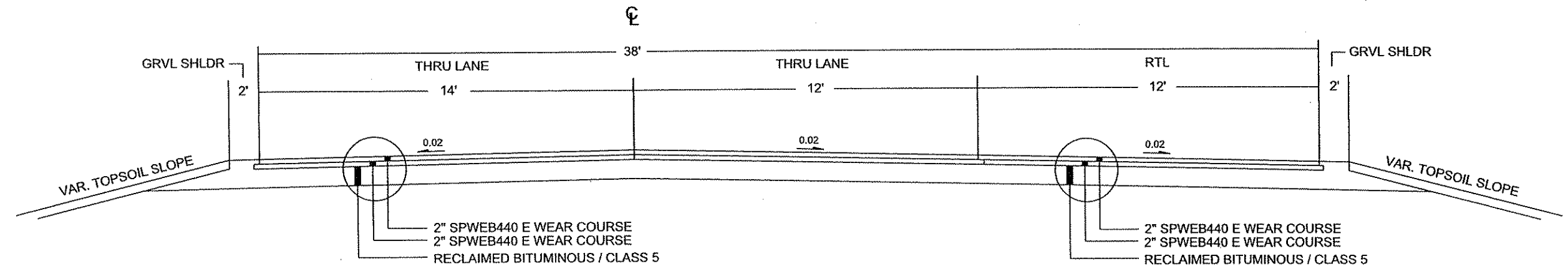

**GENERAL NOTES:**  
 - ALL CROSS SLOPES ARE APPROXIMATE  
 - UNLESS OTHERWISE SPECIFIED, THE CLASS 5 CROSS SLOPES SHALL BE THE SAME AS THE FINISHED SURFACE OF THE MAINLINE.

NO	DATE	BY	CKD	APPR	REVISION

NAME: P:\13-01-00\CSAH\_13\_(Cedar-CSAH24)\Plan7\_TYPICALS.dgn 02/22/2013 8:42:39 AM

I HEREBY CERTIFY THAT THIS PLAN WAS PREPARED BY ME OR UNDER MY DIRECT SUPERVISION AND THAT I AM A DULY LICENSED PROFESSIONAL ENGINEER UNDER THE LAWS OF THE STATE OF MINNESOTA.  
 PRINT NAME: ANDREW WITTER  
 SIGNATURE: *Andrew Witter*  
 DATE: 3/7/13 LICENSE NO. 42757

DRAWN BY JF DATE 1/18/2013  
 DESIGN BY JF DATE 1/18/2013  
 CHECKED BY GA DATE 1/29/2013

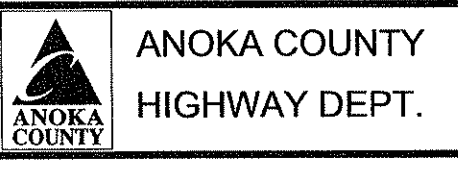

STATE PROJECT NO. \_\_\_\_\_  
 STATE AID PROJECT NO. \_\_\_\_\_  
 CITY PROJECT NO. \_\_\_\_\_  
 COUNTY PROJECT NO. CP 13-13-13

TYPICALS  
 Sheet 11 of 27 Sheets

Beginning chain ALI13 description

Point 1 N 227,426.8700 E 495,046.9230 Sta 10+00.00

Course from 1 to 2 S 89° 54' 02.85" E Dist 4,509.3318

Point 2 N 227,419.0620 E 499,556.2480 Sta 55+09.33

Course from 2 to PC ALI13-1 N 89° 04' 53.20" E Dist 107.7202

Curve Data

Curve ALI13-1				
P.I. Station	62+48.63	N	227,451.7335	E 500,294.7772
Delta	=	83° 04' 03.13" (LT)		
Degree	=	8° 02' 08.10"		
Tangent	=	631.5814		
Length	=	1,033.7460		
Radius	=	713.0257		
External	=	239.4976		
Long Chord	=	945.5595		
Mid. Ord.	=	179.2796		
P.C. Station	56+17.05	N	227,420.7889	E 499,663.9544
P.T. Station	66+50.80	N	228,081.6795	E 500,340.1987
C.C.		N	228,132.9582	E 499,629.0194
Back	= N	87° 11' 29.92" E		
Ahead	= N	4° 07' 26.78" E		
Chord Bear	= N	45° 39' 28.35" E		

Course from PT ALI13-1 to 3 N 1° 47' 21.33" E Dist 99.3250

Point 3 N 228,180.9560 E 500,343.3000 Sta 67+50.12

Course from 3 to 4 N 0° 10' 24.17" W Dist 1,434.5366

Point 4 N 229,615.4860 E 500,338.9590 Sta 81+84.66

Course from 4 to 5 N 0° 10' 02.84" W Dist 2,449.1555

Point 5 N 232,064.6310 E 500,331.8010 Sta 106+33.82

Course from 5 to 6 N 0° 28' 26.63" E Dist 636.3408

Point 6 N 232,700.9500 E 500,337.0660 Sta 112+70.16

Course from 6 to 7 Due West Dist 16.7642

Point 7 N 232,700.9500 E 500,320.3018 Sta 112+86.92

Ending chain ALI13 description

13-01-00 11-15-12 Coing CSAH #13 Overlap  
Overlap 13-01-00 ST. Francis

Core #1 .45 mile E. of Jct 13 (or 300' W. of Holly St. LEB, 229) Bit 2 3/4" Bit sand 1 1/4" NO BASE

Core #2 South Side of 234th LEB #13 (Winn) Bit 9" Bit sand 1 1/2" NO BASE

Core #3 12-6-12 LWB @ approx .8 mile E. of 13 (Cedar) or approx 500' E of R.R. tracks 3'S. of Jct line Bit 4 3/8" + Bit Sand NO BASE

Core #4 LNB approx 500'S. of 24 or approx 100' N. of E 236th Lane 3' W. of Jct line Bit 4 1/2" + Bit Sand NO BASE

Core #5 LNB approx 250'S. of mail box 23311 4' W. of Jct line Bit 6 1/2" + Bit Sand NO BASE

Core #6 0.1 mile South of 23216 mailbox c lan area LWB 3' E. of Jct line Bit 3 7/8" + bit Sand NO BASE

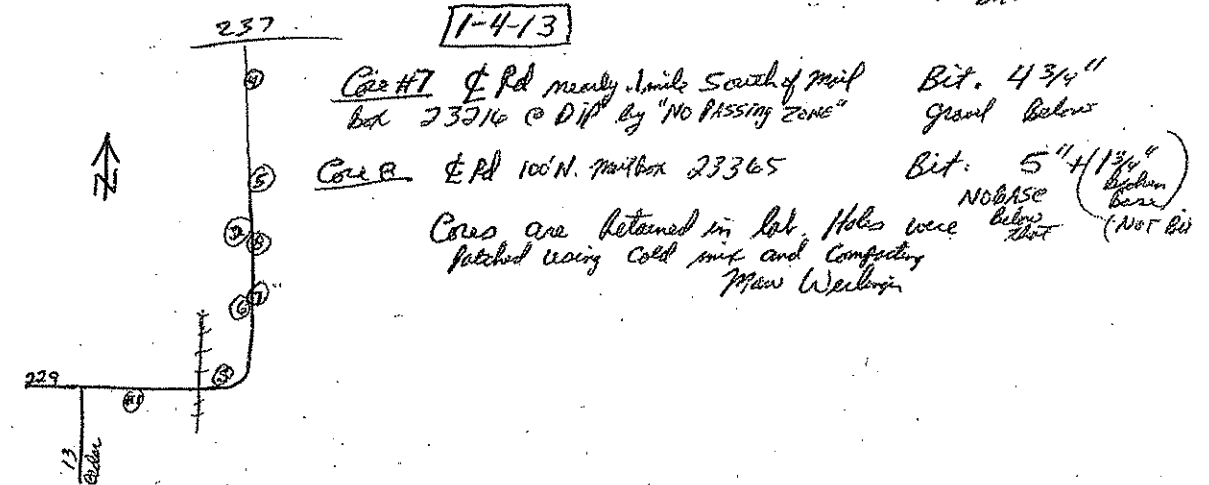

CORE INFO FOR INFORMATIONAL PURPOSES ONLY  
CONTRACTOR TO FIELD VERIFY.

NO	DATE	BY	CKD	APPR	REVISION

NAME: P:\13-01-00\CSAH\_13 (Cedar-CSAH24)\Plan\8 ALIGNMENT.dgn 02/22/2013 8:46:23 AM

I HEREBY CERTIFY THAT THIS PLAN WAS PREPARED BY ME OR UNDER MY DIRECT SUPERVISION AND THAT I AM A DULY LICENSED PROFESSIONAL ENGINEER UNDER THE LAWS OF THE STATE OF MINNESOTA.

PRINT NAME: ANDREW WITTER

SIGNATURE: *Andrew Witter*

DATE: 3/7/13 LICENSE NO. 42757

DRAWN BY: JF DATE: 1/18/2013

DESIGN BY: JF DATE: 1/18/2013

CHECKED BY: GA DATE: 1/29/2013



ANOKA COUNTY  
HIGHWAY DEPT.

STATE PROJECT NO. \_\_\_\_\_  
STATE AID PROJECT NO. \_\_\_\_\_  
CITY PROJECT NO. \_\_\_\_\_  
COUNTY PROJECT NO. CP 13-13-13

ALIGNMENT / CORE INFORMATION

Sheet 12 of 27 Sheets

BEGIN PROJECT 13-13-13  
STA 10+68

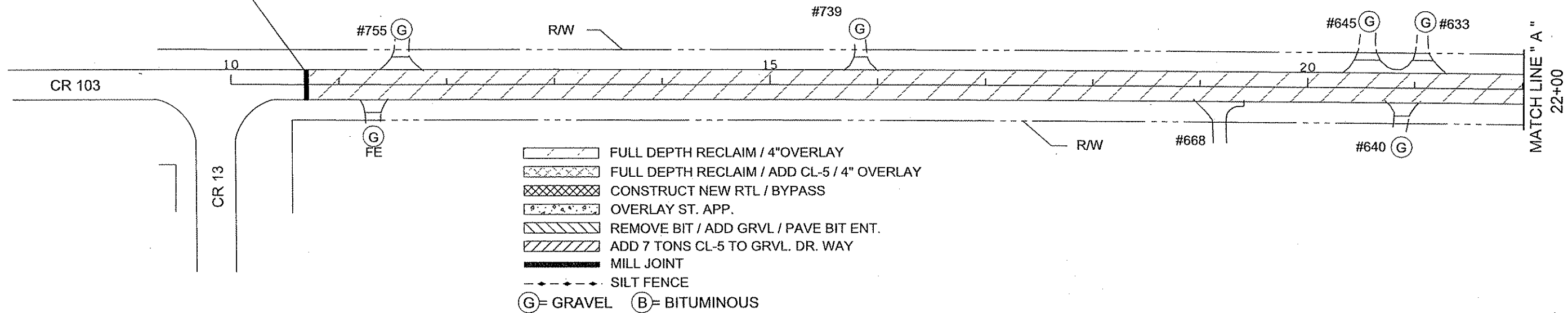

- FULL DEPTH RECLAIM / 4" OVERLAY
- FULL DEPTH RECLAIM / ADD CL-5 / 4" OVERLAY
- CONSTRUCT NEW RTL / BYPASS
- OVERLAY ST. APP.
- REMOVE BIT / ADD GRVL / PAVE BIT ENT.
- ADD 7 TONS CL-5 TO GRVL. DR. WAY
- MILL JOINT
- SILT FENCE
- (G)**= GRAVEL    **(B)**= BITUMINOUS

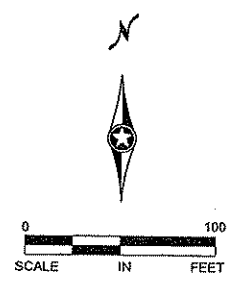

REMOVE 71' - 24" CMP  
INSTALL 72' - 24" RCP PIPE AND 2 - 6' 24" APRONS WITH ROCK BEDDING IF BYPASS IS ADDED  
TOTAL LENGTH END OF APRON TO END OF APRON 84'  
( SOUTH END OF APRON TO BE INSTALLED AT SAME LOCATION )

INSTALL 64' - 24" RCP PIPE AND 2 - 6' 24" APRONS WITH ROCK BEDDING IF NO BYPASS IS ADDED  
TOTAL LENGTH END OF APRON TO END OF APRON 76'  
PIPE TO BE INSTALLED AT SAME INV. ELEV.  
( SOUTH END OF APRON TO BE INSTALLED 3' SOUTH OF EX-LOC. )

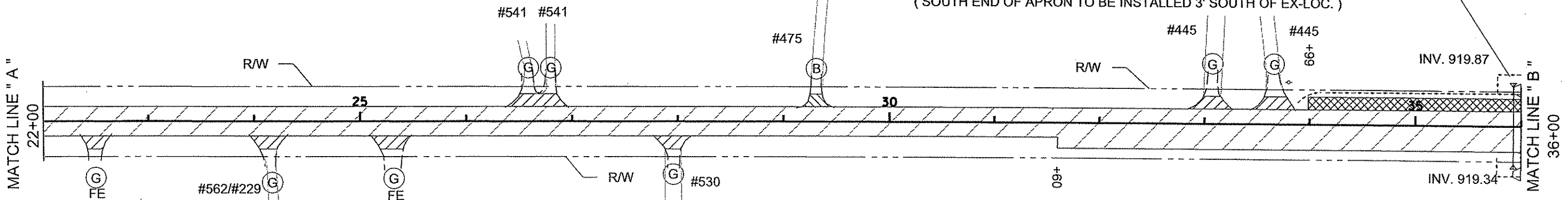

- FULL DEPTH RECLAIM / 4" OVERLAY
- FULL DEPTH RECLAIM / ADD CL-5 / 4" OVERLAY
- CONSTRUCT NEW RTL / BYPASS
- OVERLAY ST. APP.
- REMOVE BIT / ADD GRVL / PAVE BIT ENT.
- ADD 7 TONS CL-5 TO GRVL. DR. WAY
- MILL JOINT
- SILT FENCE
- (G)**= GRAVEL    **(B)**= BITUMINOUS

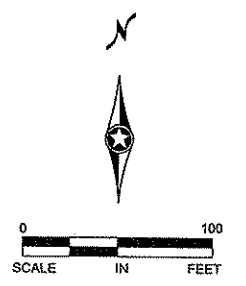

NO	DATE	BY	CKD	APPR	REVISION
NAME: P:13-01-00\CSAH_13 (Cedar-CSAH24)\Plan\9 PLAN.dgn					
DATE: 02/28/2013 9:16:11 AM					

I HEREBY CERTIFY THAT THIS PLAN WAS PREPARED BY ME OR UNDER MY DIRECT SUPERVISION AND THAT I AM A DULY LICENSED PROFESSIONAL ENGINEER UNDER THE LAWS OF THE STATE OF MINNESOTA.

PRINT NAME: ANDREW WITTER

SIGNATURE: *Andrew Witter*

DATE: 3/7/13 LICENSE NO. 42757

DRAWN BY: JF DATE: 1/18/2013

DESIGN BY: JF DATE: 1/18/2013

CHECKED BY: GA DATE: 1/29/2013



STATE PROJECT NO. \_\_\_\_\_

STATE AID PROJECT NO. \_\_\_\_\_

CITY PROJECT NO. \_\_\_\_\_

COUNTY PROJECT NO. CP 13-13-13

CONSTRUCTION PLAN

STA 10+68 TO 36+00

Sheet 13 of 27 Sheets

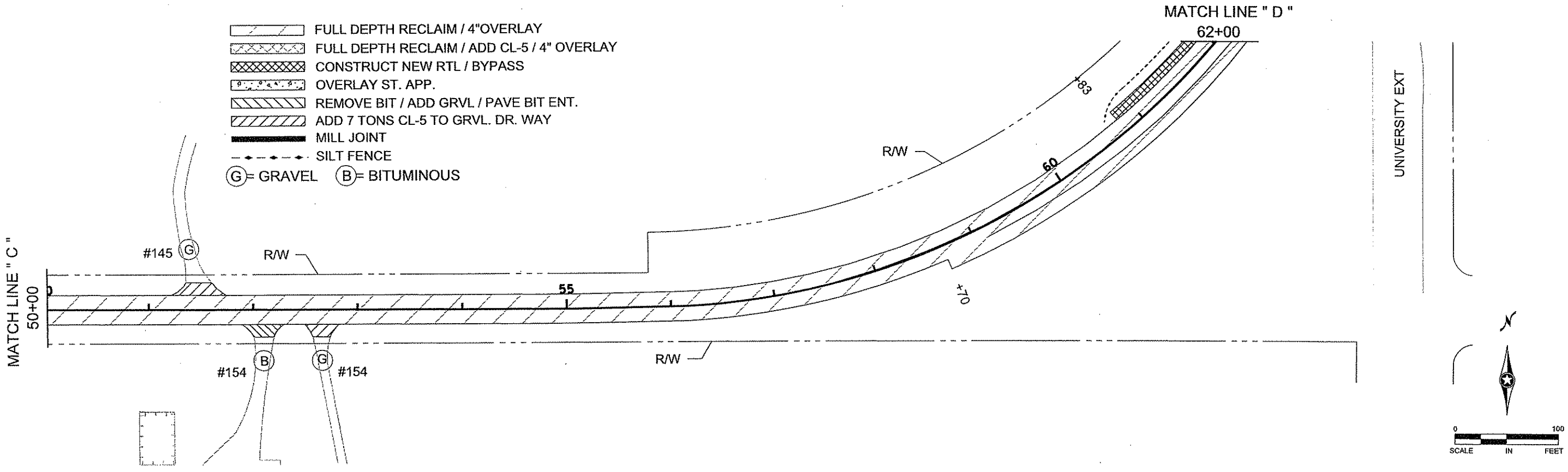
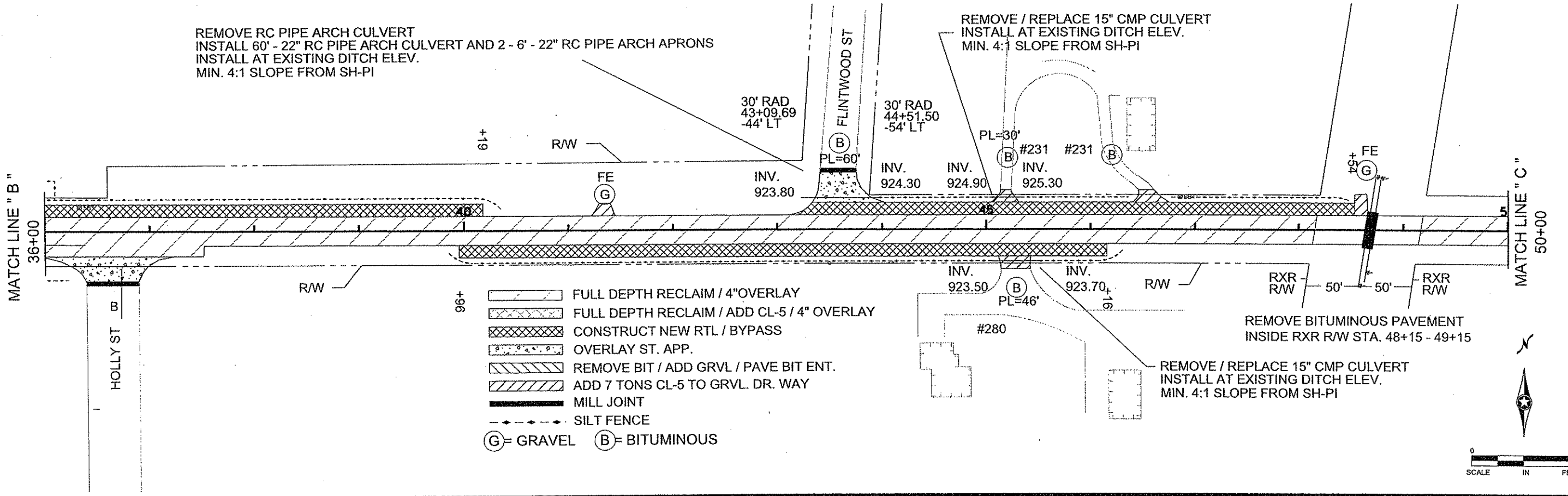

NO	DATE	BY	CKD	APPR	REVISION

NAME: P:\13-01-00\CSAH\_13\_(Cedar-CSAH24)\Plan9\_PLAN.dgn  
 02/28/2013 9:16:35 AM

I HEREBY CERTIFY THAT THIS PLAN WAS PREPARED BY ME OR UNDER MY DIRECT SUPERVISION AND THAT I AM A DULY LICENSED PROFESSIONAL ENGINEER UNDER THE LAWS OF THE STATE OF MINNESOTA.

PRINT NAME: ANDREW WITTER  
 SIGNATURE: *[Signature]*  
 DATE: 3/7/13 LICENSE NO. 42757

DRAWN BY: JF DATE: 1/18/2013  
 DESIGN BY: JF DATE: 1/18/2013  
 CHECKED BY: GA DATE: 1/29/2013

**ANOKA COUNTY**  
**HIGHWAY DEPT.**

STATE PROJECT NO. \_\_\_\_\_  
 STATE AID PROJECT NO. \_\_\_\_\_  
 CITY PROJECT NO. \_\_\_\_\_  
 COUNTY PROJECT NO. CP 13-13-13

CONSTRUCTION PLAN  
 STA 36+00 TO 62+00  
 Sheet 14 of 27 Sheets



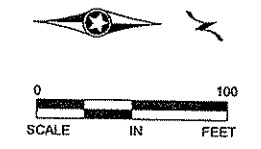
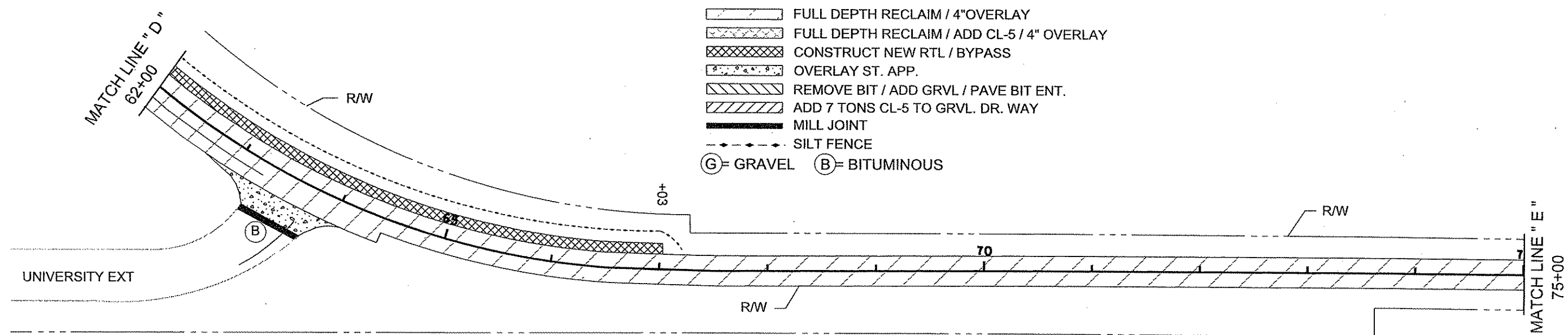

RECLAIM AND ADD ADDITIONAL CL-5  
 FILL IN EXISTING DIP 100' NORTH OF X-PIPE  
 NEW LOWPOINT OF ROAD AT X-PIPE  
 PROPOSED LOW PT. CENTERLINE CL-5 @ X-PIPE ELEV OF 911.50  
 STA. 75+20 - 77+20

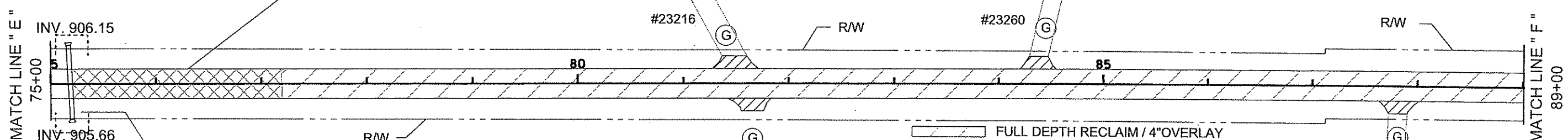

REMOVE 70' - 48" CMP  
 INSTALL 56' RCP 58" ARCH PIPE AND 2 - 8' - 58" RCP ARCH APRONS IN ROCK BEDDING.  
 TOTAL LENGTH END APRON TO END APRON IS TO BE 72'  
 PIPE TO BE INSTALLED AT SAME INV. ELEV.  
 ( EXTEND 1' N,S FROM END OF EX. PIPE )

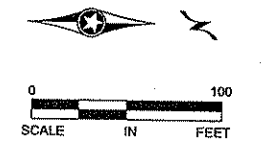

NO	DATE	BY	CKD	APPR	REVISION

NAME: P:113-01-00\CSAH\_13\_(Cedar-CSAH24)\Plan\9\_PLAN.dgn      02/28/2013      9:17:14 AM

I HEREBY CERTIFY THAT THIS PLAN WAS PREPARED BY ME OR UNDER MY DIRECT SUPERVISION AND THAT I AM A DULY LICENSED PROFESSIONAL ENGINEER UNDER THE LAWS OF THE STATE OF MINNESOTA.  
 PRINT NAME: ANDREW WITTER  
 SIGNATURE: *Andrew Witter*  
 DATE: 2/27/13      LICENSE NO. 42757

DRAWN BY: JF      DATE: 1/18/2013  
 DESIGN BY: JF      DATE: 1/18/2013  
 CHECKED BY: GA      DATE: 1/29/2013



**ANOKA COUNTY  
 HIGHWAY DEPT.**

STATE PROJECT NO. \_\_\_\_\_  
 STATE AID PROJECT NO. \_\_\_\_\_  
 CITY PROJECT NO. \_\_\_\_\_  
 COUNTY PROJECT NO. CP 13-13-13

**CONSTRUCTION PLAN**  
 STA 62+00 TO 89+00  
 Sheet 15 of 27 Sheets

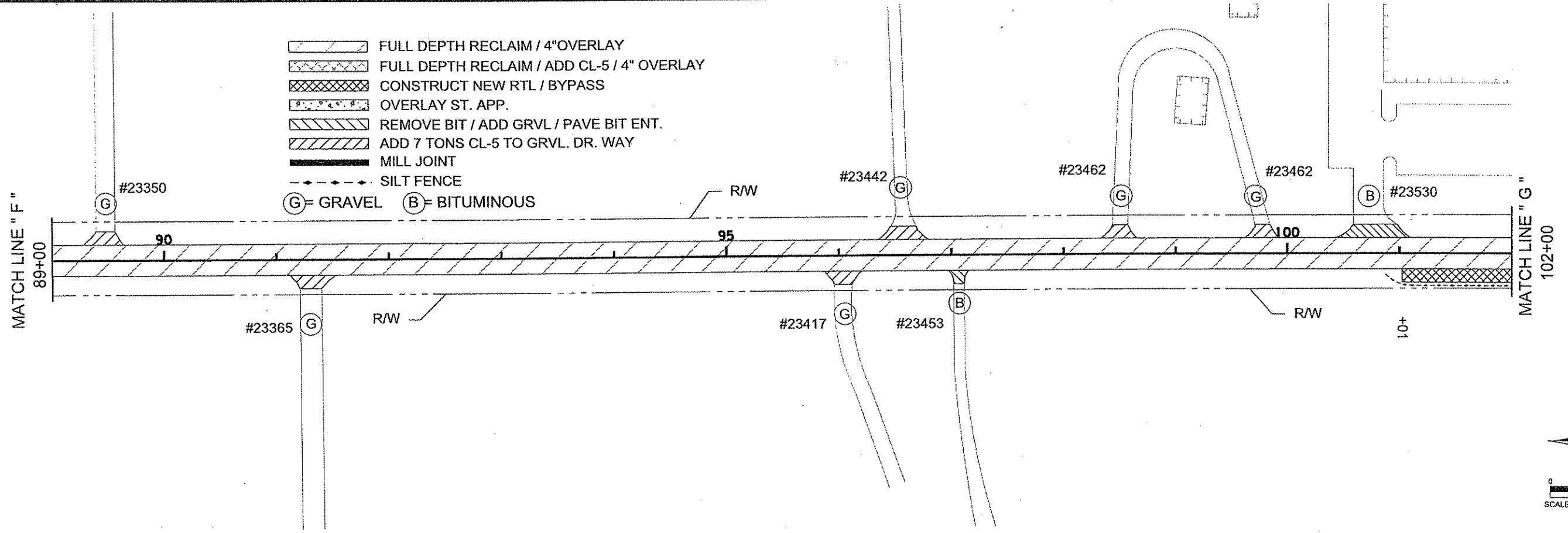

- FULL DEPTH RECLAIM / 4" OVERLAY
- FULL DEPTH RECLAIM / ADD CL-5 / 4" OVERLAY
- CONSTRUCT NEW RTL / BYPASS
- OVERLAY ST. APP.
- REMOVE BIT / ADD GRVL / PAVE BIT ENT.
- ADD 7 TONS CL-5 TO GRVL. DR. WAY
- MILL JOINT
- SILT FENCE
- (G)** = GRAVEL    **(B)** = BITUMINOUS

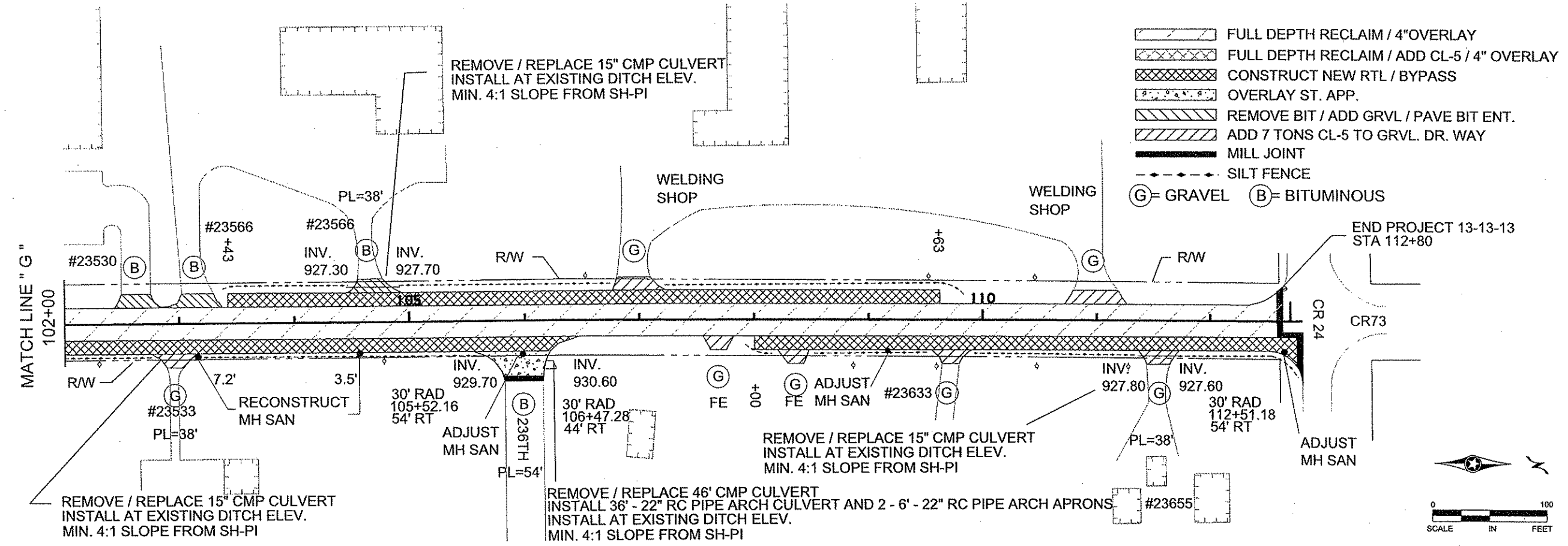
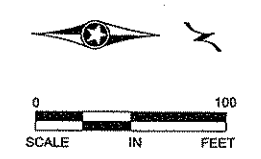

- FULL DEPTH RECLAIM / 4" OVERLAY
- FULL DEPTH RECLAIM / ADD CL-5 / 4" OVERLAY
- CONSTRUCT NEW RTL / BYPASS
- OVERLAY ST. APP.
- REMOVE BIT / ADD GRVL / PAVE BIT ENT.
- ADD 7 TONS CL-5 TO GRVL. DR. WAY
- MILL JOINT
- SILT FENCE
- (G)** = GRAVEL    **(B)** = BITUMINOUS

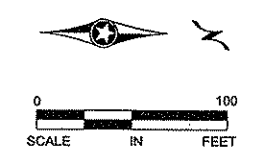

NO	DATE	BY	CKD	APPR	REVISION
NAME: P:\13-01-00\CSAH_13_(Cedar-CSAH24)\Plan\9_PLAN.dgn					

I HEREBY CERTIFY THAT THIS PLAN WAS PREPARED BY ME OR UNDER MY DIRECT SUPERVISION AND THAT I AM A DULY LICENSED PROFESSIONAL ENGINEER UNDER THE LAWS OF THE STATE OF MINNESOTA.

PRINT NAME: ANDREW WITTER

SIGNATURE: *[Signature]*

DATE: 3/7/13 LICENSE NO. 42757

DRAWN BY: JF DATE: 1/18/2013

DESIGN BY: JF DATE: 1/18/2013

CHECKED BY: GA DATE: 1/29/2013

**ANOKA COUNTY**  
**HIGHWAY DEPT.**

STATE PROJECT NO. \_\_\_\_\_

STATE AID PROJECT NO. \_\_\_\_\_

CITY PROJECT NO. \_\_\_\_\_

COUNTY PROJECT NO. CP 13-13-13

CONSTRUCTION PLAN

STA 89+00 TO 112+80

Sheet 16 of 27 Sheets

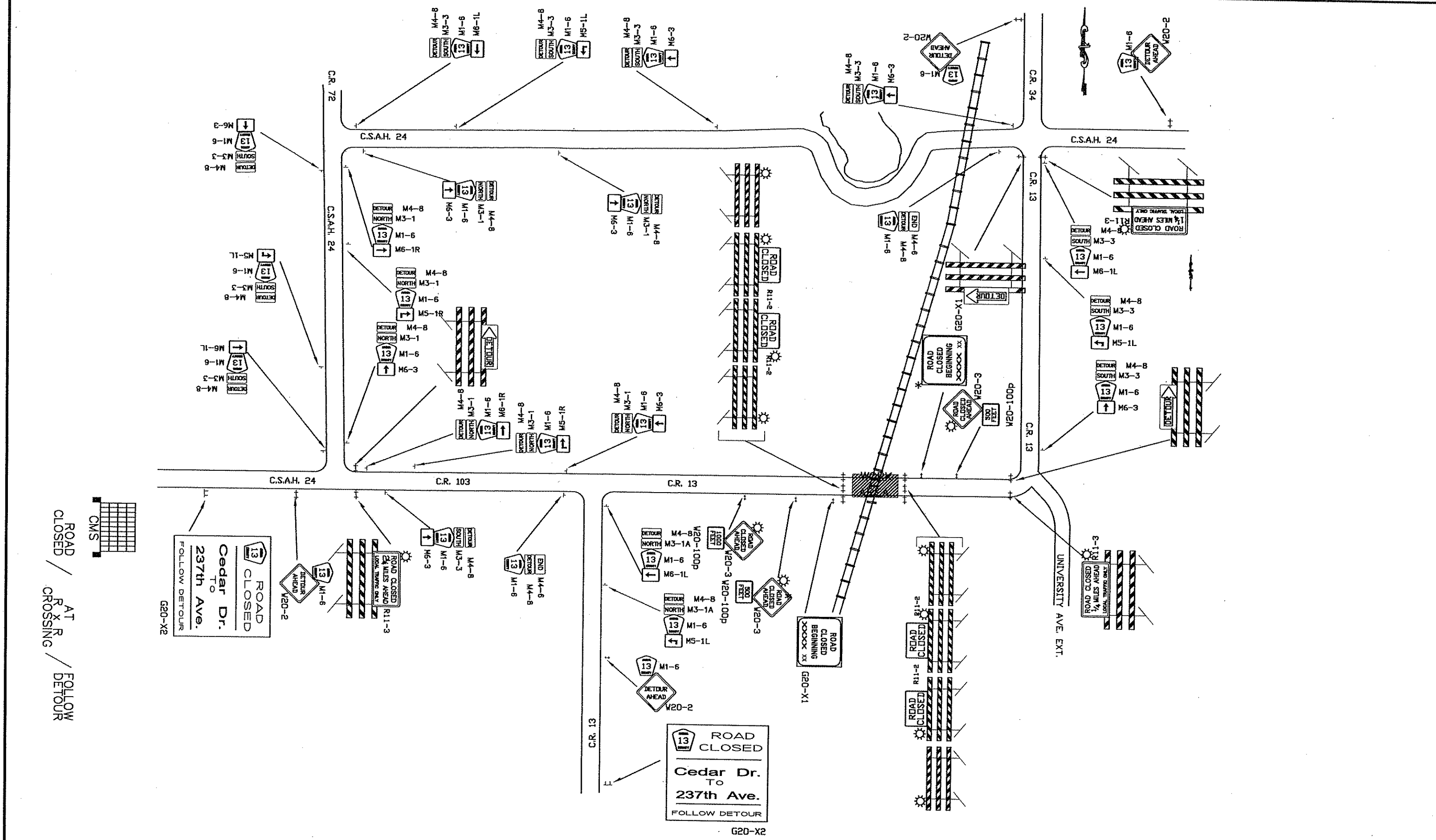

NO	DATE	BY	CKD	APPR	REVISION
NAME: P:\13-01-00\CSAH 13\Base\TRAFFIC\DET 13-13-13.dwg					

I HEREBY CERTIFY THAT THIS PLAN WAS PREPARED BY ME OR UNDER MY DIRECT SUPERVISION AND THAT I AM A DULY REGISTERED PROFESSIONAL ENGINEER UNDER THE LAWS OF THE STATE OF MINNESOTA.  
 PRINT NAME: ANDREW WITTER  
 SIGNATURE: *Andrew Witter*  
 DATE: 3/7/13 REG. NO. 42757

DRAWN BY: RLB DATE: 01/29/13  
 DESIGN BY: RLB DATE: 01/29/13  
 CHECKED BY: JR DATE: 2/01/13



**ANOKA COUNTY**  
**HIGHWAY DEPT.**

STATE PROJECT NO. \_\_\_\_\_  
 STATE AID PROJECT NO. \_\_\_\_\_  
 STATE AID PROJECT NO. \_\_\_\_\_  
 COUNTY PROJECT NO. 13-13-13

M. U. T. C. D.				M. U. T. C. D.			
CODE	SIZE	INSERT	QTY	CODE	SIZE	INSERT	QTY
M1-6	24" x 24"	13	4	M4-6	24" x 12"	END	
W20-2	48" x 48"	DETOUR AHEAD	4	M4-8	24" x 12"	13	2
W20-3	48" x 48"	ROAD CLOSED AHEAD	3	M1-6	24" x 24"	13	
W29-100P	24" x 18"	500 FEET	2	M4-8	24" x 12"	DETOUR SOUTH	M5-1L
W29-100P	24" x 18"	1000 FEET	1	M3-3	24" x 12"	13	M6-1L
				M1-6	24" x 24"	13	M6-3
					21" x 15"		
R11-2	48" x 30"	ROAD CLOSED	4	M4-8	24" x 12"	DETOUR NORTH	M5-1R
M4-10R	48" x 18"	DETOUR	2	M3-1	24" x 12"	13	M5-1L
8 FT. TYPE III			2	M1-6	24" x 24"	13	M6-1L
					21" x 15"		M6-1R
M4-10L	48" x 18"	DETOUR	1				M6-3
8 FT. TYPE III			1	R11-3a	48" x 18"	ROAD CLOSED 1/4 MILES AHEAD LOCAL TRAFFIC ONLY	
				8 FT. TYPE III			
				R11-3a	48" x 18"	ROAD CLOSED 1/4 MILES AHEAD LOCAL TRAFFIC ONLY	1
				8 FT. TYPE III			1
				R11-3a	48" x 18"	ROAD CLOSED 2 1/4 MILES AHEAD LOCAL TRAFFIC ONLY	1
				8 FT. TYPE III			1
R11-2	48" x 30"	ROAD CLOSED	2	G20-X2	132" x 108"	ROAD CLOSED CEDAR DR. TO 227TH AVE. FOLLOW DETOUR	2
8 FT. TYPE III			2	G20-X3	114" x 20"	BEGINS XX/XX/XX	2
R11-2	48" x 30"	ROAD CLOSED	2	G20-X1	48" x 48"	THIS ROAD WILL BE CLOSED MONTHLY	2
8 FT. TYPE III			2				
THE NUMBER OF DAYS BE LIMITED FOR THE RAD CLOSURE TO BE 14 DAYS		CMS	1				

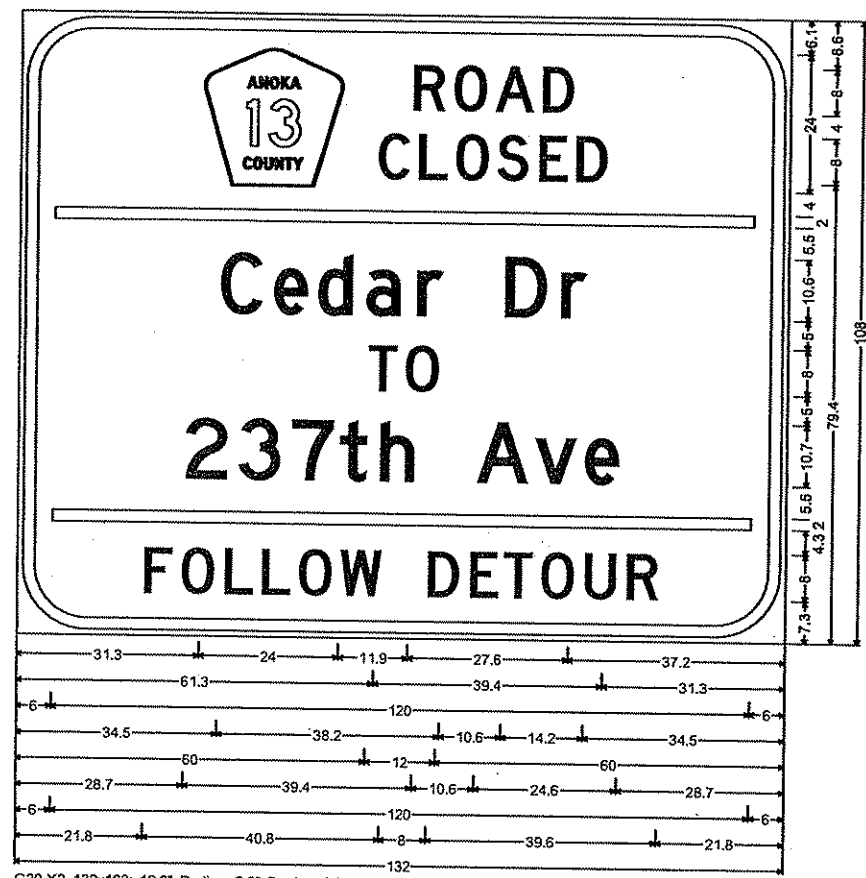

G20-X2\_132x108; 12.0" Radius, 2.0" Border, 1.0" Indent, Black on Orange;  
 [ROAD] D; [CLOSED] D; [Cedar Dr] D; [TO] D; [237th Ave] D; [FOLLOW] D; [DETOUR] D;

INSTALL G20-X2 SIGNS 7 DAYS PRIOR WITH "BEGIN/DATE" PLATE;  
 REMOVE PLATE AT START DATE OF CONSTRUCTION SO SIGN READS "FOLLOW DETOUR".

G20-X1 SIGN TO BE INSTALLED A MINIMUM OF SEVEN DAYS PRIOR TO ACTUAL CLOSING DATE OF ROAD CLOSURE AND IMPLEMENTATION OF DETOUR SIGNING. SIGNS TO BE REMOVED AT TIME OF DETOUR INSTALLATION.

STANDARD TRAFFIC CONTROL NOTES:

- 1) LOCATIONS OF ALL SIGNS ARE APPROXIMATE, EXACT LOCATIONS WILL BE DETERMINED IN THE FIELD BY THE ENGINEER.
- 2) ALL BARRICADES AND SIGNS SHALL BE PROPERLY WEIGHTED WITH SANDBAGS.
- 3) ALL BARRICADES SHALL HAVE REFLECTIVE MATERIAL ON BOTH SIDES.
- 4) ALL BARRICADES MARKINGS SHALL BE SLANTED IN ACCORDANCE WITH THE MINNESOTA MANUAL OF UNIFORM TRAFFIC CONTROL DEVICES.
- 5) ALL TRAFFIC CONTROL DEVICES SHALL CONFORM TO THE MOST RECENT EDITION OF THE MINNESOTA MANUAL ON UNIFORM TRAFFIC CONTROL DEVICES.
- 6) ADDITIONS OR CHANGES TO THIS PLAN MAY BE MADE AS DETERMINED BY THE ENGINEER.

I HEREBY CERTIFY THAT THIS PLAN WAS PREPARED BY ME OR UNDER MY DIRECT SUPERVISION AND THAT I AM A DULY REGISTERED PROFESSIONAL ENGINEER UNDER THE LAWS OF THE STATE OF MINNESOTA. PRINT NAME: ANDREW WITJER SIGNATURE: [Signature] DATE: 3/7/13 REG. NO. 42757					DRAWN BY: RLB DATE 01/29/13 DESIGN BY: DATE CHECKED BY: DATE	ANOKA COUNTY HIGHWAY DEPT. STATE PROJECT NO. _____ STATE AID PROJECT NO. _____ STATE AID PROJECT NO. _____ COUNTY PROJECT NO. 13-13-13	DETOUR Sheet 18 of 27 Sheets
NO	DATE	BY	CKD	APPR	REVISION		
NAME: P:\13-01-00\CSAH 13\Base\TRAFFIC\DET 13-13-13.dwg							

**PERMANENT PAVEMENT MARKING PLAN**  
NOTES AND GUIDELINES

**GENERAL INFORMATION:**

THE ENGINEER'S INVOLVEMENT IN THE APPLICATION OF THE MATERIAL SHALL BE LIMITED TO FIELD CONSULTATION AND INSPECTION. ANOKA COUNTY HIGHWAY DEPARTMENT WILL PLACE NECESSARY "SPOTTING" AT APPROPRIATE POINTS TO PROVIDE HORIZONTAL CONTROL FOR STRIPING AND TO DETERMINE NECESSARY STARTING AND CUTOFF POINTS, LONGITUDINAL JOINTS, PAVEMENT EDGES AND EXISTING MARKINGS MAY SERVE AS HORIZONTAL CONTROL WHEN SO DIRECTED.

EDGE LINES AND LANE LINES ARE TO BE BROKEN ONLY AT INTERSECTIONS WITH PUBLIC ROADS AND AT PRIVATE ENTRANCES IF THEY ARE CONTROLLED BY A YIELD SIGN, STOP SIGN OR TRAFFIC SIGNAL. THE BREAK POINT IS TO BE AT THE START OF THE RADIUS FOR THE INTERSECTION OR AT MARKED STOP LINES OR CROSSWALKS.

A TOLERANCE OF 1/4 INCH UNDER OR 1/4 INCH OVER THE SPECIFIED WIDTH WILL BE ALLOWED FOR STRIPING PROVIDED THE VARIATION IS GRADUAL AND DOES NOT DETRACT FROM THE GENERAL APPEARANCE. BROKEN LINE SEGMENTS MAY VARY UP TO ONE-HALF FOOT FROM THE SPECIFIED LENGTHS PROVIDED THE OVER AND UNDER VARIATIONS ARE REASONABLY COMPENSATORY. ALIGNMENT DEVIATIONS FROM THE CONTROL GUIDE SHALL NOT EXCEED 1 INCH. MATERIAL SHALL NOT BE APPLIED OVER LONGITUDINAL JOINTS, ESTABLISHMENT OF APPLICATION TOLERANCES SHALL NOT RELIEVE THE CONTRACTOR OF THEIR RESPONSIBILITY TO COMPLY AS CLOSELY AS PRACTICABLE WITH THE PLANNED DIMENSIONS.

**EPOXY:**

THE ROAD SURFACE SHALL BE CLEANED AT THE DIRECTION OF THE ENGINEER JUST PRIOR TO APPLICATION. PAVEMENT CLEANING SHALL CONSIST OF AT LEAST BRUSHING WITH A ROTARY BROOM (NON-METALLIC) OR AS RECOMMENDED BY THE MATERIAL MANUFACTURER AND ACCEPTABLE TO THE ENGINEER. NEW PORTLAND CEMENT CONCRETE SURFACES SHALL BE SANDBLAST CLEANED TO REMOVE ANY SURFACE TREATMENT AND/OR LAITANCE ON LOW SPEED (SPEED LIMIT 35 MPH OR LESS) URBAN PORTLAND CEMENT CONCRETE ROADWAYS. SANDBLAST CLEANING SHALL BE USED FOR ALL EPOXY PAVEMENT MARKINGS.

THE EPOXY MARKING APPLICATION SHALL IMMEDIATELY FOLLOW THE PAVEMENT CLEANING. GLASS BEANS SHALL BE APPLIED IMMEDIATELY AFTER APPLICATION OF THE EPOXY RESIN LINE TO PROVIDE AN IMMEDIATE NO-TRACK SYSTEM.

AN EPOXY RESIN LINE 4" WIDE AND 15 MILL THICKNESS (WET), REQUIRES AN APPLICATION RATE OF ONE (1) GALLON OF COMPONENTS FOR 320 FEET OF LINE. GLASS BEADS SHALL BE APPLIED AT A POUND PER GALLON RATE SUFFICIENT TO ACHIEVE AN ACCEPTABLE NO-TRACK SYSTEM.

OPERATIONS SHALL BE CONDUCTED ONLY WHEN THE ROAD PAVEMENT SURFACE TEMPERATURES ARE 50 DEGREES FAHRENHEIT OR GREATER.

PERMANENT PAVEMENT MARKINGS SHALL NOT BE PLACED OVER TEMPORARY TAPE MARKINGS.

**PREFORMED THERMOPLASTIC:**

THE PREFORMED THERMOPLASTIC MARKINGS SHALL BE APPLIED IN ACCORDANCE WITH THE MANUFACTURER'S RECOMMENDATIONS ON CLEAN AND DRY SURFACES. SEE SPECIAL PROVISIONS FOR PREFORMED THERMOPLASTIC MARKING SPECIFICATIONS.

**PAINT:**

AT THE TIME OF APPLYING THE MARKING MATERIAL, THE APPLICATION AREA SHALL BE FREE OF CONTAMINATION. THE CONTRACTOR SHALL CLEAN THE ROADWAY SURFACE PRIOR TO THE LINE APPLICATION IN A MANNER AND TO THE EXTENT REQUIRED BY THE ENGINEER.

GLASS BEADS SHALL BE APPLIED IMMEDIATELY AFTER APPLICATION OF THE PAINT LINE.

EXCEPT WHEN USED AS A TEMPORARY MARKING, PAVEMENT MARKINGS SHALL ONLY BE APPLIED IN SEASONABLE WEATHER WHEN AIR TEMPERATURE IS 50 DEGREES FARHENHEIT OR HIGHER AND SHALL NOT BE APPLIED WHEN THE WIND OR OTHER CONDITIONS CAUSE A FILD OR DUST TO BE DEPOSITED ON THE PAVEMENT SURFACE AFTER CLEANING AND BEFORE THE MARKING MATERIAL CAN BE APPLIED.

THE FILLING OF TANKS, POURING OF MATERIALS OR CLEANING OF EQUIPMENT SHALL NOT BE PERFORMED ON UNPROTECTED PAVEMENT SURFACES UNLESS ADEQUATE PROVISIONS ARE MADE TO PREVENT SPILLAGE OF MATERIAL.

**SYMBOLS & MATERIALS LEGEND**

■ CROSSWALK BLOCK WHITE PREFORMED THERMOPLASTIC

↩ PAVEMENT MESSAGE (LEFT ARROW) PREFORMED THERMOPLASTIC

**STRIPING KEY**

○ CIRCLE - EPOXY      □ SQUARE PREFORMED THERMOPLASTIC

△ TRIANGLE - PAINT

⬠ PENTAGON - REMOVABLE PREFORMED PLASTIC MARKING

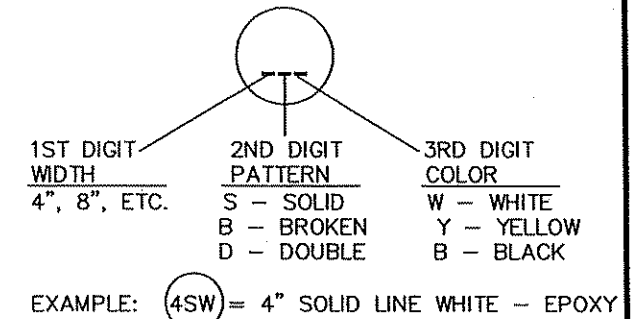

PAVEMENT MARKING QUANTITIES		
Item	Quantity	Units
24" WHITE PREF THERMOPLASTIC	24	Lin Ft
4" SOLID LINE WHITE - EPOXY	21285	Lin Ft
4" BROKEN LINE WHITE - EPOXY (10 ft stripe / 40 ft gap)	160	Lin Ft
4" SOLID LINE YELLOW - EPOXY	2534	Lin Ft
4" BROKEN LINE WHITE - EPOXY (10 ft stripe / 40 ft gap)	160	Lin Ft
4" DOUBLE SOLID LINE YELLOW - EPOXY	3722	Lin Ft
PAVT MSSG (RR CROSSING) PREF THERMOPLASTIC	2	EACH

NO	DATE	BY	CHKD	APPR	REVISION

I HEREBY CERTIFY THAT THIS PLAN WAS PREPARED BY ME OR UNDER MY DIRECT SUPERVISION AND THAT I AM A DULY LICENSED PROFESSIONAL ENGINEER UNDER THE LAWS OF THE STATE OF MINNESOTA.  
 PRINT NAME: ANDREW WITTER  
 SIGNATURE: [Signature]  
 DATE: 3/7/13 LICENSE NO. 42757

DRAWN BY: MTH DATE: 12/26/2012  
 DESIGN BY: MTH DATE: 12/26/2012  
 CHECKED BY: JR DATE: 2/20/2013



**ANOKA COUNTY**  
**HIGHWAY DEPT.**

STATE PROJECT NO. \_\_\_\_\_  
 STATE AID PROJECT NO. \_\_\_\_\_  
 STATE AID PROJECT NO. \_\_\_\_\_  
 COUNTY PROJECT NO. 13-13-13

**PERMANENT MARKING**  
**TABULATION**  
 Sheet 19 of 27 Sheets

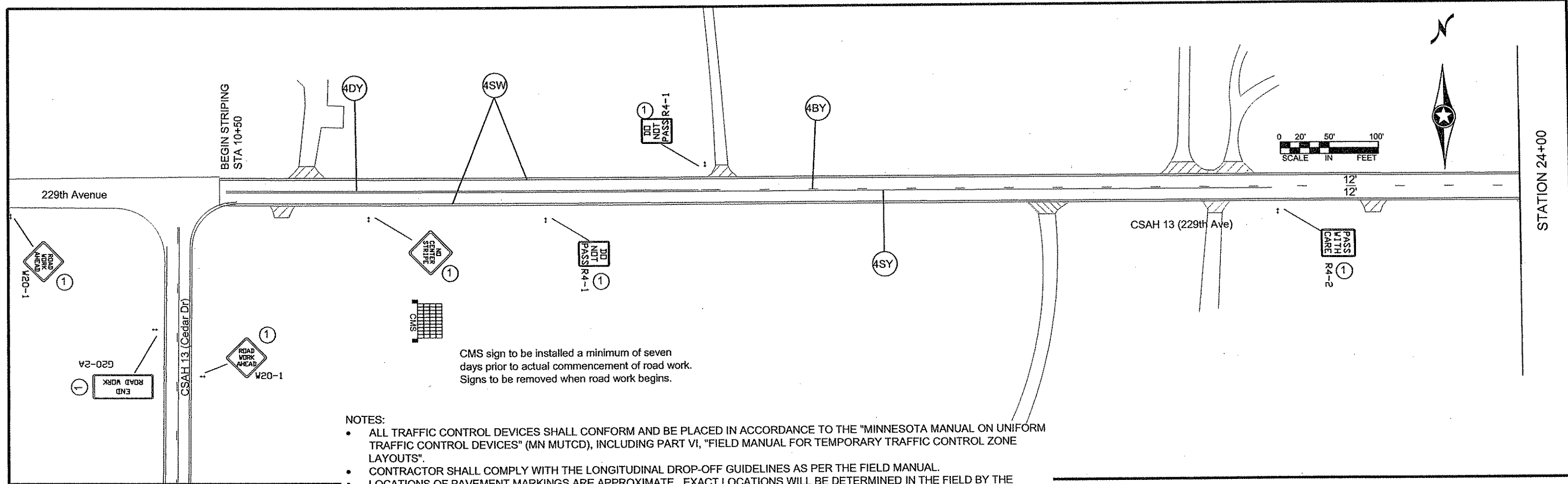

**NOTES:**

- ALL TRAFFIC CONTROL DEVICES SHALL CONFORM AND BE PLACED IN ACCORDANCE TO THE "MINNESOTA MANUAL ON UNIFORM TRAFFIC CONTROL DEVICES" (MN MUTCD), INCLUDING PART VI, "FIELD MANUAL FOR TEMPORARY TRAFFIC CONTROL ZONE LAYOUTS".
- CONTRACTOR SHALL COMPLY WITH THE LONGITUDINAL DROP-OFF GUIDELINES AS PER THE FIELD MANUAL.
- LOCATIONS OF PAVEMENT MARKINGS ARE APPROXIMATE. EXACT LOCATIONS WILL BE DETERMINED IN THE FIELD BY THE ENGINEER.
- CONTRACTOR SHALL SUPPLY AND INSTALL THE PORTABLE CHANGEABLE MESSAGE SIGN (CMS) A MINIMUM OF SEVEN DAYS PRIOR TO ACTUAL COMMENCEMENT OF ROAD WORK, TO A LOCATION AS SPECIFIED BY THE ENGINEER. SIGNS TO BE REMOVED WHEN ROAD WORK BEGINS. PAYMENT SHALL BE MADE AS PER ITEM 2563.613 PORTABLE CHANGEABLE MESSAGE SIGN BY THE UNIT/DAY.
- CONTRACTOR SHALL SUPPLY AND ERECT THE TEMPORARY TRAFFIC CONTROL SIGNS AS SHOWN ON THIS DRAWING AND DETAILED IN THE SPECIAL PROVISIONS FROM THE TIME WORK COMMENCES ON THIS ROADWAY UNTIL THIS ROADWAY IS PERMANENTLY STRIPED. ALL NECESSARY TEMPORARY TRAFFIC CONTROL SIGNS SHALL BE PAID FOR AS PART OF TRAFFIC CONTROL LUMP SUM.
- ALL PERMANENT STRIPING AND PAVEMENT MESSAGES SHALL BE PLACED WITHIN 72 HOURS OF MAINLINE PAVING.
- ANY REQUIRED PERMANENT SIGNING SHALL BE INSTALLED THE SAME DAY AS PERMANENT STRIPING
- ALL EXISTING SIGNING SHALL REMAIN IN PLACE DURING CONSTRUCTION. ALL SALVAGED AND REINSTALLED SIGNS SHALL BE INSTALLED ON TEMPORARY SUPPORTS UNTIL THE PERMANENT INSTALLATION CAN BE MADE. THIS WILL BE CONSIDERED AS INCIDENTAL TO INSTALL SIGN TYPE C.

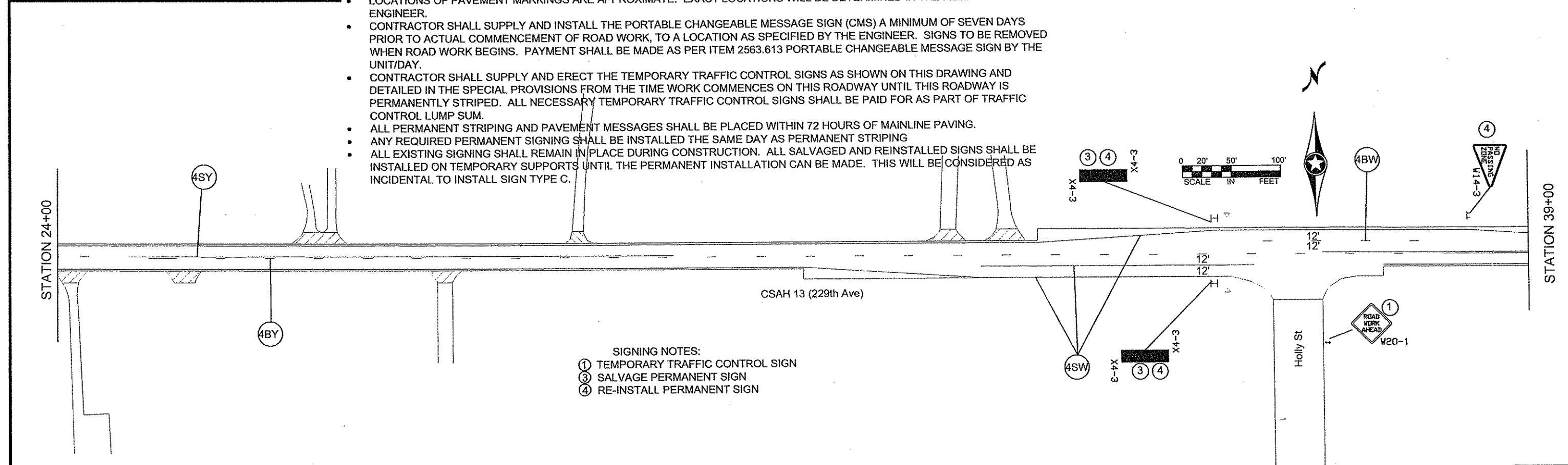

- SIGNING NOTES:**
- ① TEMPORARY TRAFFIC CONTROL SIGN
  - ③ SALVAGE PERMANENT SIGN
  - ④ RE-INSTALL PERMANENT SIGN

NO	DATE	BY	CKD	APPR	REVISION

NAME: P:\13-01-00\CSAH 13\Base\TRAFFIC\SIGNING AND STRIPING.DWG

I HEREBY CERTIFY THAT THIS PLAN WAS PREPARED BY ME OR UNDER MY DIRECT SUPERVISION AND THAT I AM A DULY REGISTERED PROFESSIONAL ENGINEER UNDER THE LAWS OF THE STATE OF MINNESOTA.

PRINT NAME: **ANDREW WITTER**

SIGNATURE: *[Signature]*

DATE: **3/7/13** REG. NO. **42757**

DRAWN BY: **MTH** DATE **1/12/2013**

DESIGN BY: **MTH** DATE **1/12/2013**

CHECKED BY: **JR** DATE **2/20/2013**

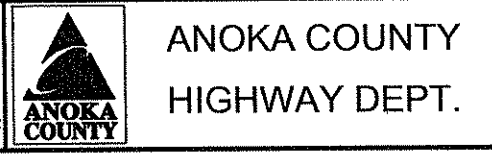

STATE PROJECT NO. \_\_\_\_\_

STATE AID PROJECT NO. \_\_\_\_\_

STATE AID PROJECT NO. \_\_\_\_\_

COUNTY PROJECT NO. **13-13-13**

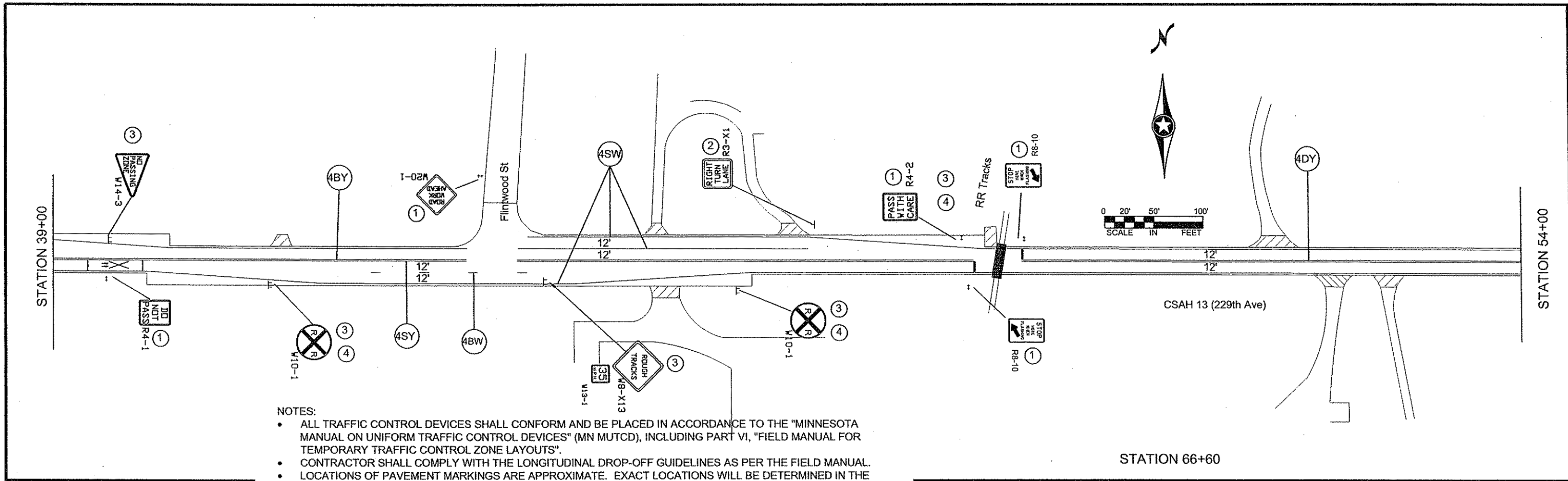

- NOTES:
- ALL TRAFFIC CONTROL DEVICES SHALL CONFORM AND BE PLACED IN ACCORDANCE TO THE "MINNESOTA MANUAL ON UNIFORM TRAFFIC CONTROL DEVICES" (MN MUTCD), INCLUDING PART VI, "FIELD MANUAL FOR TEMPORARY TRAFFIC CONTROL ZONE LAYOUTS".
  - CONTRACTOR SHALL COMPLY WITH THE LONGITUDINAL DROP-OFF GUIDELINES AS PER THE FIELD MANUAL.
  - LOCATIONS OF PAVEMENT MARKINGS ARE APPROXIMATE. EXACT LOCATIONS WILL BE DETERMINED IN THE FIELD BY THE ENGINEER.
  - CONTRACTOR SHALL SUPPLY AND INSTALL THE PORTABLE CHANGEABLE MESSAGE SIGN (CMS) A MINIMUM OF SEVEN DAYS PRIOR TO ACTUAL COMMENCEMENT OF ROAD WORK, TO A LOCATION AS SPECIFIED BY THE ENGINEER. SIGNS TO BE REMOVED WHEN ROAD WORK BEGINS. PAYMENT SHALL BE MADE AS PER ITEM 2563.613 PORTABLE CHANGEABLE MESSAGE SIGN BY THE UNIT/DAY.
  - CONTRACTOR SHALL SUPPLY AND ERECT THE TEMPORARY TRAFFIC CONTROL SIGNS AS SHOWN ON THIS DRAWING AND DETAILED IN THE SPECIAL PROVISIONS FROM THE TIME WORK COMMENCES ON THIS ROADWAY UNTIL THIS ROADWAY IS PERMANENTLY STRIPED. ALL NECESSARY TEMPORARY TRAFFIC CONTROL SIGNS SHALL BE PAID FOR AS PART OF TRAFFIC CONTROL LUMP SUM.
  - ALL PERMANENT STRIPING AND PAVEMENT MESSAGES SHALL BE PLACED WITHIN 72 HOURS OF MAINLINE PAVING.
  - ANY REQUIRED PERMANENT SIGNING SHALL BE INSTALLED THE SAME DAY AS PERMANENT STRIPING
  - ALL EXISTING SIGNING SHALL REMAIN IN PLACE DURING CONSTRUCTION. ALL SALVAGED AND REINSTALLED SIGNS SHALL BE INSTALLED ON TEMPORARY SUPPORTS UNTIL THE PERMANENT INSTALLATION CAN BE MADE. THIS WILL BE CONSIDERED AS INCIDENTAL TO INSTALL SIGN TYPE C.

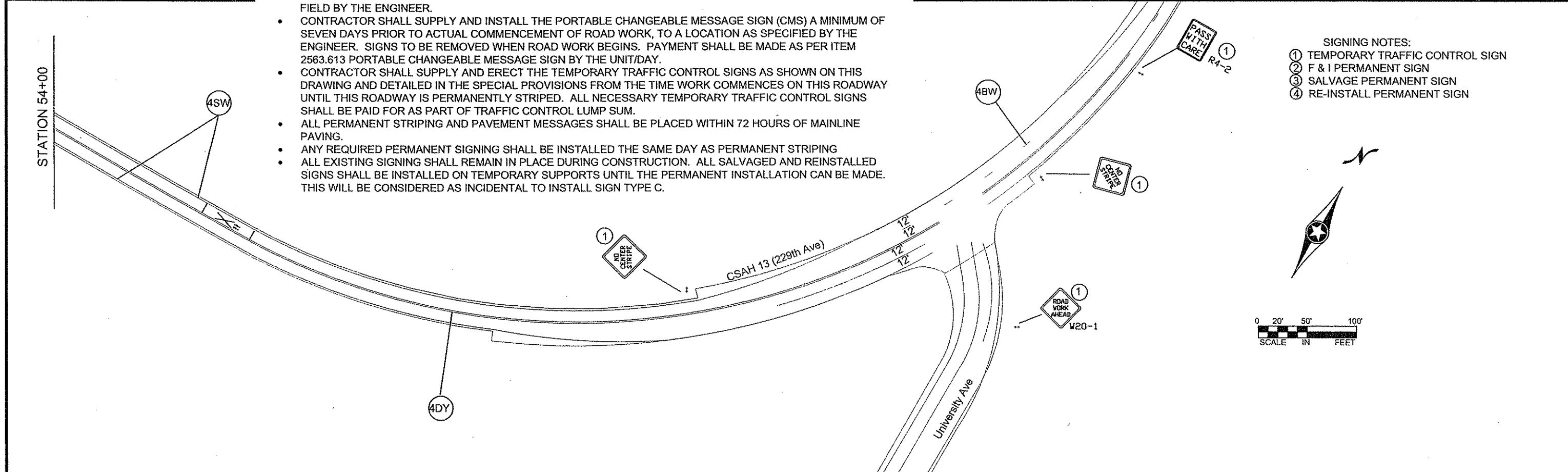

- SIGNING NOTES:
- ① TEMPORARY TRAFFIC CONTROL SIGN
  - ② F & I PERMANENT SIGN
  - ③ SALVAGE PERMANENT SIGN
  - ④ RE-INSTALL PERMANENT SIGN

NO	DATE	BY	CKD	APPR	REVISION

NAME: P:113-01-00ICSAH 131Base1TRAFFICISIGNING AND STRIPING.DWG

I HEREBY CERTIFY THAT THIS PLAN WAS PREPARED BY ME OR UNDER MY DIRECT SUPERVISION AND THAT I AM A DULY REGISTERED PROFESSIONAL ENGINEER UNDER THE LAWS OF THE STATE OF MINNESOTA.

PRINT NAME: ANDREW WITTER

SIGNATURE: *Andrew Witter*

DATE: 2/20/2013 REG. NO. 42757

DRAWN BY: MTH DATE 1/12/2013

DESIGN BY: MTH DATE 1/12/2013

CHECKED BY: JR DATE 2/20/2013

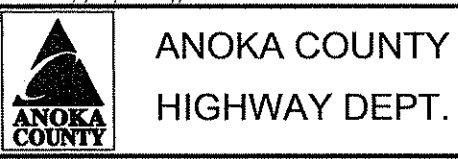

STATE PROJECT NO. \_\_\_\_\_

STATE AID PROJECT NO. \_\_\_\_\_

STATE AID PROJECT NO. \_\_\_\_\_

COUNTY PROJECT NO. 13-13-13

TEMPORARY SIGNING  
PERMANENT SIGNING, STRIPING  
AND PAVEMENT MESSAGES

Sheet 21 of 27 Sheets

- SIGNING NOTES:
- ① TEMPORARY TRAFFIC CONTROL SIGN
  - ③ SALVAGE PERMANENT SIGN
  - ④ RE-INSTALL PERMANENT SIGN

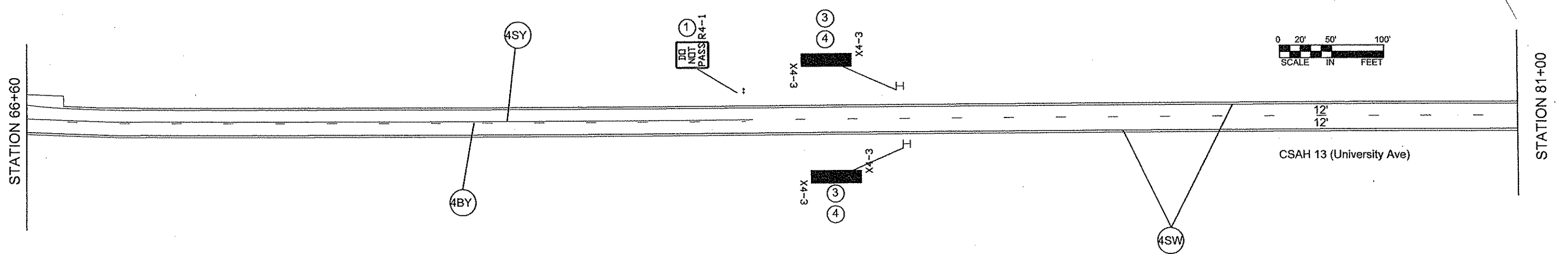

NOTES:

- ALL TRAFFIC CONTROL DEVICES SHALL CONFORM AND BE PLACED IN ACCORDANCE TO THE "MINNESOTA MANUAL ON UNIFORM TRAFFIC CONTROL DEVICES" (MN MUTCD), INCLUDING PART VI, "FIELD MANUAL FOR TEMPORARY TRAFFIC CONTROL ZONE LAYOUTS".
- CONTRACTOR SHALL COMPLY WITH THE LONGITUDINAL DROP-OFF GUIDELINES AS PER THE FIELD MANUAL.
- LOCATIONS OF PAVEMENT MARKINGS ARE APPROXIMATE. EXACT LOCATIONS WILL BE DETERMINED IN THE FIELD BY THE ENGINEER.
- CONTRACTOR SHALL SUPPLY AND INSTALL THE PORTABLE CHANGEABLE MESSAGE SIGN (CMS) A MINIMUM OF SEVEN DAYS PRIOR TO ACTUAL COMMENCEMENT OF ROAD WORK, TO A LOCATION AS SPECIFIED BY THE ENGINEER. SIGNS TO BE REMOVED WHEN ROAD WORK BEGINS. PAYMENT SHALL BE MADE AS PER ITEM 2563.613 PORTABLE CHANGEABLE MESSAGE SIGN BY THE UNIT/DAY.
- CONTRACTOR SHALL SUPPLY AND ERECT THE TEMPORARY TRAFFIC CONTROL SIGNS AS SHOWN ON THIS DRAWING AND DETAILED IN THE SPECIAL PROVISIONS FROM THE TIME WORK COMMENCES ON THIS ROADWAY UNTIL THIS ROADWAY IS PERMANENTLY STRIPED. ALL NECESSARY TEMPORARY TRAFFIC CONTROL SIGNS SHALL BE PAID FOR AS PART OF TRAFFIC CONTROL LUMP SUM.
- ALL PERMANENT STRIPING AND PAVEMENT MESSAGES SHALL BE PLACED WITHIN 72 HOURS OF MAINLINE PAVING.
- ANY REQUIRED PERMANENT SIGNING SHALL BE INSTALLED THE SAME DAY AS PERMANENT STRIPING.
- ALL EXISTING SIGNING SHALL REMAIN IN PLACE DURING CONSTRUCTION. ALL SALVAGED AND REINSTALLED SIGNS SHALL BE INSTALLED ON TEMPORARY SUPPORTS UNTIL THE PERMANENT INSTALLATION CAN BE MADE. THIS WILL BE CONSIDERED AS INCIDENTAL TO INSTALL SIGN TYPE C.

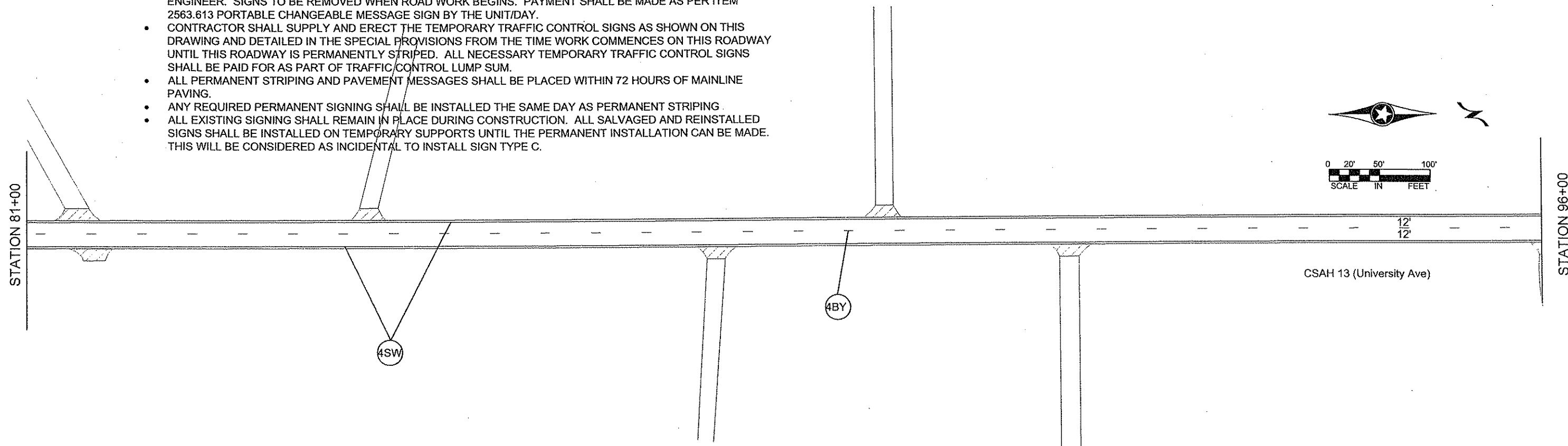

NO	DATE	BY	CKD	APPR	REVISION

NAME: P:\13-01-00\CSAH 13\Base\TRAFFIC\SIGNING AND STRIPING.DWG

I HEREBY CERTIFY THAT THIS PLAN WAS PREPARED BY ME OR UNDER MY DIRECT SUPERVISION AND THAT I AM A DULY REGISTERED PROFESSIONAL ENGINEER UNDER THE LAWS OF THE STATE OF MINNESOTA.

PRINT NAME: ANDREW WITTER

SIGNATURE: *Andrew Witter*

DATE: 3/7/13 REG. NO. 42757

DRAWN BY: MTH DATE 1/12/2013

DESIGN BY: MTH DATE 1/12/2013

CHECKED BY: JR DATE 2/20/2013

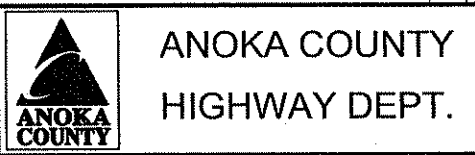

STATE PROJECT NO. \_\_\_\_\_

STATE AID PROJECT NO. \_\_\_\_\_

STATE AID PROJECT NO. \_\_\_\_\_

COUNTY PROJECT NO. 13-13-13

TEMPORARY SIGNING  
PERMANENT SIGNING, STRIPING  
AND PAVEMENT MESSAGES

Sheet 22 of 27 Sheets



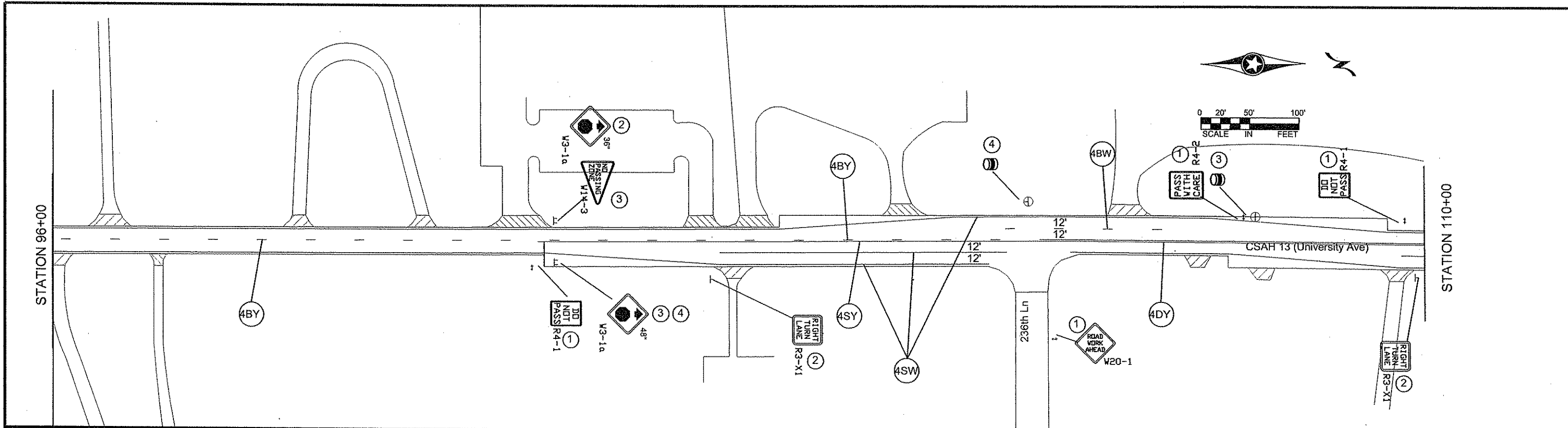

CMS sign to be installed a minimum of seven days prior to actual commencement of road work. Signs to be removed when road work begins.

NOTES:

- ALL TRAFFIC CONTROL DEVICES SHALL CONFORM AND BE PLACED IN ACCORDANCE TO THE "MINNESOTA MANUAL ON UNIFORM TRAFFIC CONTROL DEVICES" (MN MUTCD), INCLUDING PART VI, "FIELD MANUAL FOR TEMPORARY TRAFFIC CONTROL ZONE LAYOUTS".
- CONTRACTOR SHALL COMPLY WITH THE LONGITUDINAL DROP-OFF GUIDELINES AS PER THE FIELD MANUAL.
- LOCATIONS OF PAVEMENT MARKINGS ARE APPROXIMATE. EXACT LOCATIONS WILL BE DETERMINED IN THE FIELD BY THE ENGINEER.
- CONTRACTOR SHALL SUPPLY AND INSTALL THE PORTABLE CHANGEABLE MESSAGE SIGN (CMS) A MINIMUM OF SEVEN DAYS PRIOR TO ACTUAL COMMENCEMENT OF ROAD WORK, TO A LOCATION AS SPECIFIED BY THE ENGINEER. SIGNS TO BE REMOVED WHEN ROAD WORK BEGINS. PAYMENT SHALL BE MADE AS PER ITEM 2563.613 PORTABLE CHANGEABLE MESSAGE SIGN BY THE UNIT/DAY.
- CONTRACTOR SHALL SUPPLY AND ERECT THE TEMPORARY TRAFFIC CONTROL SIGNS AS SHOWN ON THIS DRAWING AND DETAILED IN THE SPECIAL PROVISIONS FROM THE TIME WORK COMMENCES ON THIS ROADWAY UNTIL THIS ROADWAY IS PERMANENTLY STRIPED. ALL NECESSARY TEMPORARY TRAFFIC CONTROL SIGNS SHALL BE PAID FOR AS PART OF TRAFFIC CONTROL LUMP SUM.
- ALL PERMANENT STRIPING AND PAVEMENT MESSAGES SHALL BE PLACED WITHIN 72 HOURS OF MAINLINE PAVING.
- ANY REQUIRED PERMANENT SIGNING SHALL BE INSTALLED THE SAME DAY AS PERMANENT STRIPING
- ALL EXISTING SIGNING SHALL REMAIN IN PLACE DURING CONSTRUCTION. ALL SALVAGED AND REINSTALLED SIGNS SHALL BE INSTALLED ON TEMPORARY SUPPORTS UNTIL THE PERMANENT INSTALLATION CAN BE MADE. THIS WILL BE CONSIDERED AS INCIDENTAL TO INSTALL SIGN TYPE C.

SIGNING NOTES:

- ① TEMPORARY TRAFFIC CONTROL SIGN
- ② F & I PERMANENT SIGN
- ③ SALVAGE PERMANENT SIGN
- ④ RE-INSTALL PERMANENT SIGN

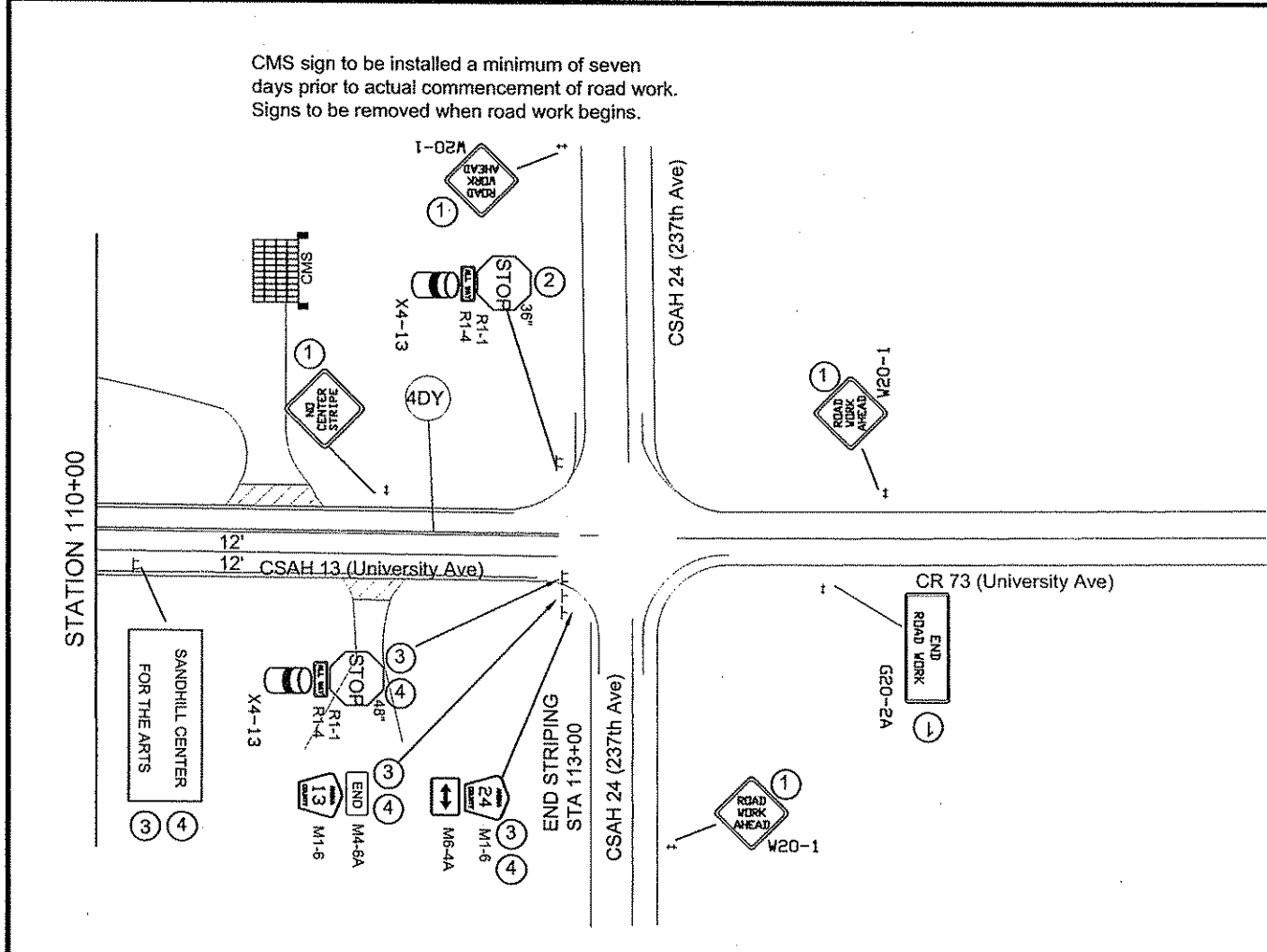

NO	DATE	BY	CKD	APPR	REVISION

I HEREBY CERTIFY THAT THIS PLAN WAS PREPARED BY ME OR UNDER MY DIRECT SUPERVISION AND THAT I AM A DULY REGISTERED PROFESSIONAL ENGINEER UNDER THE LAWS OF THE STATE OF MINNESOTA.

PRINT NAME: ANDREW WITTER

SIGNATURE: *Andrew Witter*

DATE: 3/13/13 REG. NO. 42757

DRAWN BY: MTH DATE 1/12/2013

DESIGN BY: MTH DATE 1/12/2013

CHECKED BY: JR DATE 2/20/2013

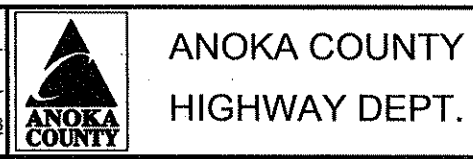

STATE PROJECT NO. \_\_\_\_\_

STATE AID PROJECT NO. \_\_\_\_\_

STATE AID PROJECT NO. \_\_\_\_\_

COUNTY PROJECT NO. 13-13-13

TEMPORARY SIGNING  
PERMANENT SIGNING, STRIPING  
AND PAVEMENT MESSAGES

Sheet 23 of 27 Sheets

**RAILROAD CROSSING PAVEMENT MARKINGS**

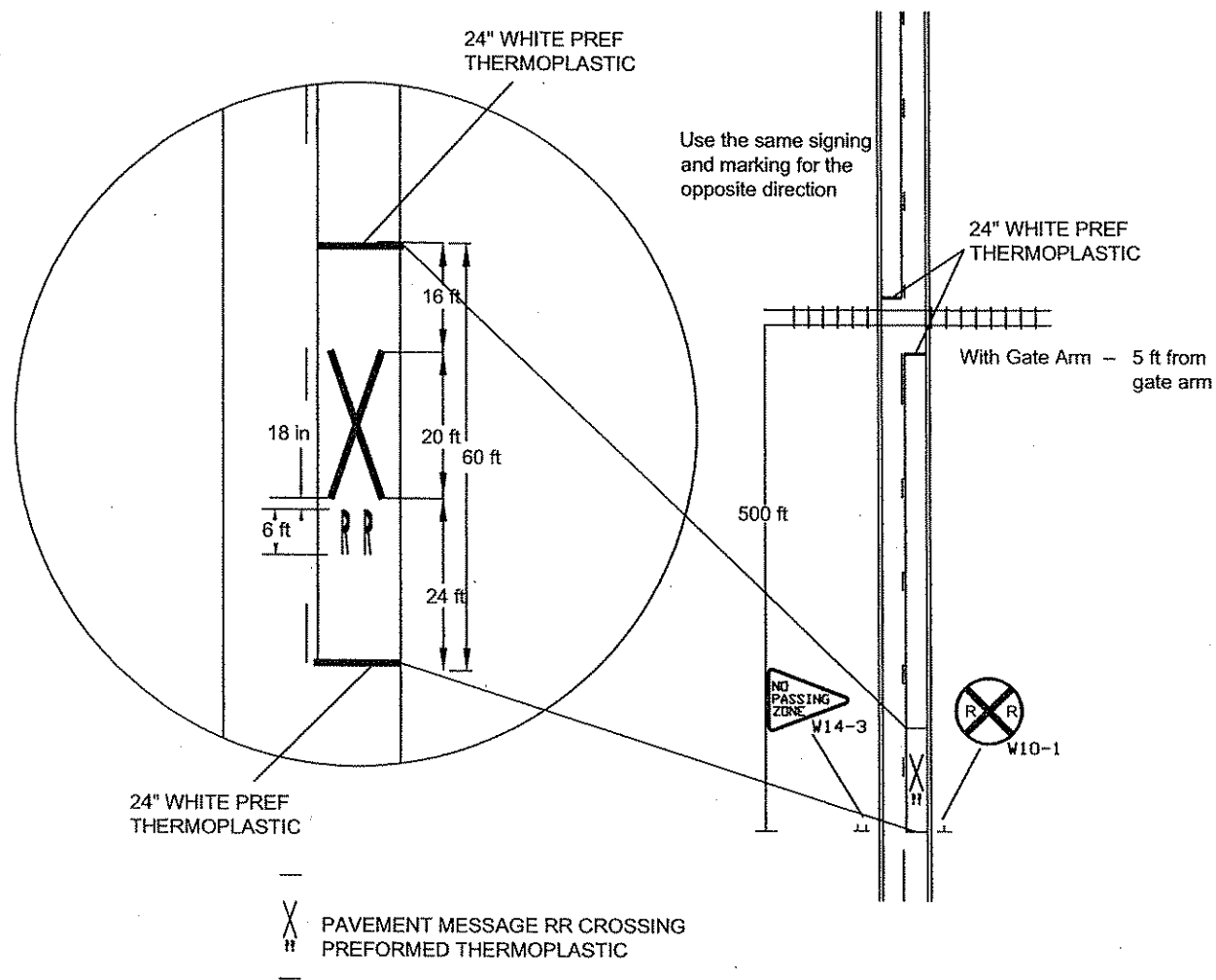

F & I PERMANENT SIGNS						
M.U.T.C.D. CODE	SIZE	PANEL AREA	INSERT	QUANTITY	No. POST	MOUNTING HEIGHT TO PAVEMENT (EACH)
		FT. <sup>2</sup>				
R1-1	36" x 36"	9.00	 R1-1 R1-4 X4-13	1	2	7.0'
R1-4	6" x 18"	1.50		1		7.0'
X4-15	4" x 15"			1		
R3-X1	30" x 30"	6.25		2	1	7.0'
W3-1a	36" x 36"	9.00		1	2	7.0'

Item	Quantity	Units
SALVAGE SIGN PANEL TYPE C	15	EACH
FURNISH SIGN PANEL TYPE C	38.25	SQ FT
INSTALL SIGN PANEL TYPE C	13	EACH

TEMPORARY TRAFFIC CONTROL SIGNS						
M.U.T.C.D. CODE	SIZE	PANEL AREA	INSERT	QUANTITY	No. POST	MOUNTING HEIGHT TO PAVEMENT (EACH)
		FT. <sup>2</sup>				
W8-12	48" x 48"	16.00		2	2	7.0'
R4-1	24" x 30"	5.00	 R4-1	6	1	7.0'
R4-2	24" x 30"	5.00	 R4-2	4	1	7.0'
R8-10	24" x 36"	6.00	 R8-10	2	1	7.0'
W8-1A	48" x 48"	16.00	 W8-1A	AS NEEDED		
W8-1A	48" x 48"	16.00	 W8-1A	AS NEEDED		
W8-8	48" x 48"	16.00	 W8-8	AS NEEDED		
W8-9	48" x 48"	16.00	 W8-9	AS NEEDED		
	48" x 48"	16.00		AS NEEDED		
W8-11	48" x 48"	16.00	 W8-11	AS NEEDED		
W20-1	48" x 48"	16.00	 W20-1	AS NEEDED (ESTIMATED 9)		
			 CMS	2		
G20-2A	48" x 24"	8.00		2		

CHANGEABLE MESSAGE BOARD - MESSAGE SEQUENCE LAYOUT

		R	O	A	D		
		W	O	R	K		
		B	E	G	I	N	S

	<	D	A	T	E	>	
		E	X	P	E	C	T
		D	E	L	A	Y	S

		U	S	E			
		A	L	T			
		R	O	U	T	E	S

NOTES:

- ALL TRAFFIC CONTROL DEVICES SHALL CONFORM AND BE PLACED IN ACCORDANCE TO THE "MINNESOTA MANUAL ON UNIFORM TRAFFIC CONTROL DEVICES" (MN MUTCD), INCLUDING PART VI, "FIELD MANUAL FOR TEMPORARY TRAFFIC CONTROL ZONE LAYOUTS".
- CONTRACTOR SHALL COMPLY WITH THE LONGITUDINAL DROP-OFF GUIDELINES AS PER THE FIELD MANUAL.
- LOCATIONS OF PAVEMENT MARKINGS ARE APPROXIMATE. EXACT LOCATIONS WILL BE DETERMINED IN THE FIELD BY THE ENGINEER.
- CONTRACTOR SHALL SUPPLY AND INSTALL THE PORTABLE CHANGEABLE MESSAGE SIGN (CMS) A MINIMUM OF SEVEN DAYS PRIOR TO ACTUAL COMMENCEMENT OF ROAD WORK, TO A LOCATION AS SPECIFIED BY THE ENGINEER. SIGNS TO BE REMOVED WHEN ROAD WORK BEGINS. PAYMENT SHALL BE MADE AS PER ITEM 2563.613 PORTABLE CHANGEABLE MESSAGE SIGN BY THE UNIT/DAY.
- CONTRACTOR SHALL SUPPLY AND ERECT THE TEMPORARY TRAFFIC CONTROL SIGNS AS SHOWN ON THIS DRAWING AND DETAILED IN THE SPECIAL PROVISIONS FROM THE TIME WORK COMMENCES ON THIS ROADWAY UNTIL THIS ROADWAY IS PERMANENTLY STRIPED. ALL NECESSARY TEMPORARY TRAFFIC CONTROL SIGNS SHALL BE PAID FOR AS PART OF TRAFFIC CONTROL LUMP SUM.
- ALL PERMANENT STRIPING AND PAVEMENT MESSAGES SHALL BE PLACED WITHIN 72 HOURS OF MAINLINE PAVING.
- ANY REQUIRED PERMANENT SIGNING SHALL BE INSTALLED THE SAME DAY AS PERMANENT STRIPING
- ALL EXISTING SIGNING SHALL REMAIN IN PLACE DURING CONSTRUCTION. ALL SALVAGED AND REINSTALLED SIGNS SHALL BE INSTALLED ON TEMPORARY SUPPORTS UNTIL THE PERMANENT INSTALLATION CAN BE MADE. THIS WILL BE CONSIDERED AS INCIDENTAL TO INSTALL SIGN TYPE C.

NO	DATE	BY	CKD	APPR	REVISION

NAME: P:\12-01-00\CSAH 20\Bases\TRAFFIC SIGNING AND STRIPING.DWG

I HEREBY CERTIFY THAT THIS PLAN WAS PREPARED BY ME OR UNDER MY DIRECT SUPERVISION AND THAT I AM A DULY REGISTERED PROFESSIONAL ENGINEER UNDER THE LAWS OF THE STATE OF MINNESOTA.

PRINT NAME: ANDREW WITTER

SIGNATURE: *Andrew Witter*

DATE: 3/11/13 REG. NO. 42757

DRAWN BY: MTH DATE 1/12/2013

DESIGN BY: MTH DATE 1/12/2013

CHECKED BY: JR DATE 2/20/2013



ANOKA COUNTY  
HIGHWAY DEPT.

STATE PROJECT NO. \_\_\_\_\_

STATE AID PROJECT NO. \_\_\_\_\_

STATE AID PROJECT NO. \_\_\_\_\_

COUNTY PROJECT NO. 13-13-13

TRAFFIC CONTROL  
QUANTITIES

Sheet 24 of 27 Sheets

SALVAGE AND RE-INSTALL PERMANENT SIGNS

STATION		SALVAGE SIGN TYPE C	INSTALL SIGN TYPE C	SIGN NUMBER
		EACH	EACH	
35+80	Rt	1	1	X4-3
				X4-3
35+80	Lt	1	1	X4-3
				X4-3
38+40	Lt		1	W14-3
39+55	Lt	1		W14-3
41+20	Rt	1	1	W10-1
44+00	Rt	1		W8-X13
				W13-1
46+00	Rt	1	1	W10-1
75+00	Rt	1	1	X4-3
				X4-3
75+00	Lt	1	1	X4-3
				X4-3
101+10	Rt	1	1	W3-1
101+10	Lt	1		W14-3
106+00	Lt		1	Term Post
108+15	Lt	1		Term Post
110+15	Rt	1	1	Sandhill
113+00	Rt	1	1	R1-1
				R1-4
				Delineator
113+00	Rt	1	1	M4-6A
				M1-6
113+00	Rt	1	1	M1-6
				M6-4A
TOTAL		15	13	

NO	DATE	BY	CHKD	APPR	REVISION

NAME: P:\12-01-00\CSAH 20\Baset\TRAFFIC\SIGNING AND STRIPING.DWG

I HEREBY CERTIFY THAT THIS PLAN WAS PREPARED BY ME OR UNDER MY DIRECT SUPERVISION AND THAT I AM A DULY REGISTERED PROFESSIONAL ENGINEER UNDER THE LAWS OF THE STATE OF MINNESOTA.

PRINT NAME: ANDREW WITTER

SIGNATURE: [Signature]

DATE: 3/7/13 REG. NO. 42757

DRAWN BY: MTH DATE 1/12/2013

DESIGN BY: MTH DATE 1/12/2013

CHECKED BY: JR DATE 2/20/2013



**ANOKA COUNTY**  
**HIGHWAY DEPT.**

STATE PROJECT NO. \_\_\_\_\_

STATE AID PROJECT NO. \_\_\_\_\_

STATE AID PROJECT NO. \_\_\_\_\_

COUNTY PROJECT NO. 13-13-13

SALVAGE AND RE-INSTALL  
PERMANENT SIGNS  
TABULATION

Sheet 25 of 27 Sheets

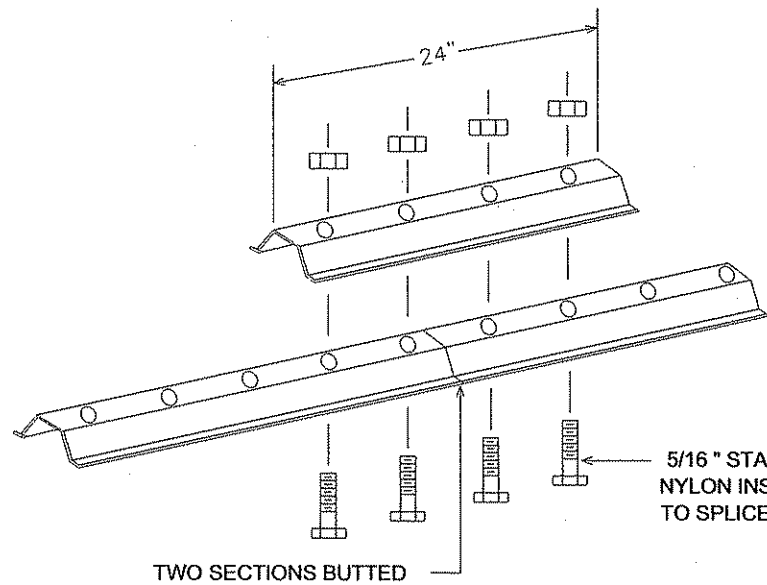

LATERAL BRACE OR STRINGER  
SPLICE DETAIL (EXPLODED VIEW)

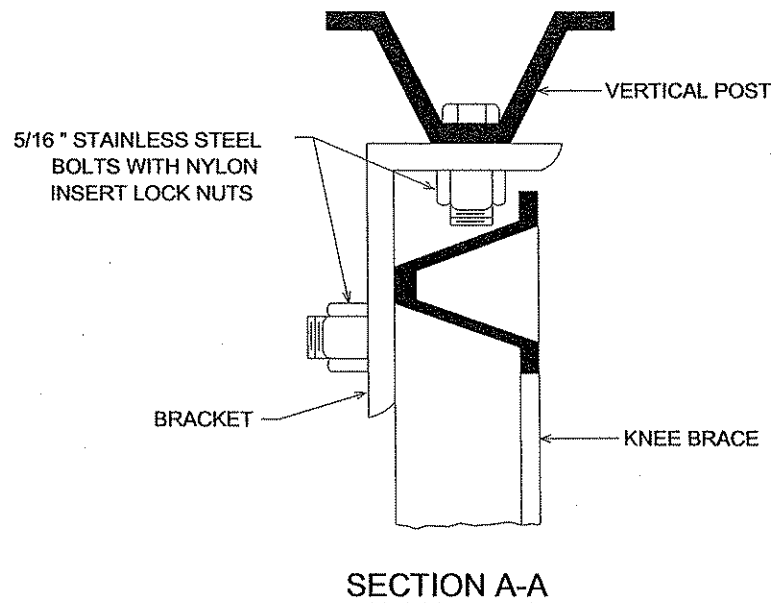

SECTION A-A

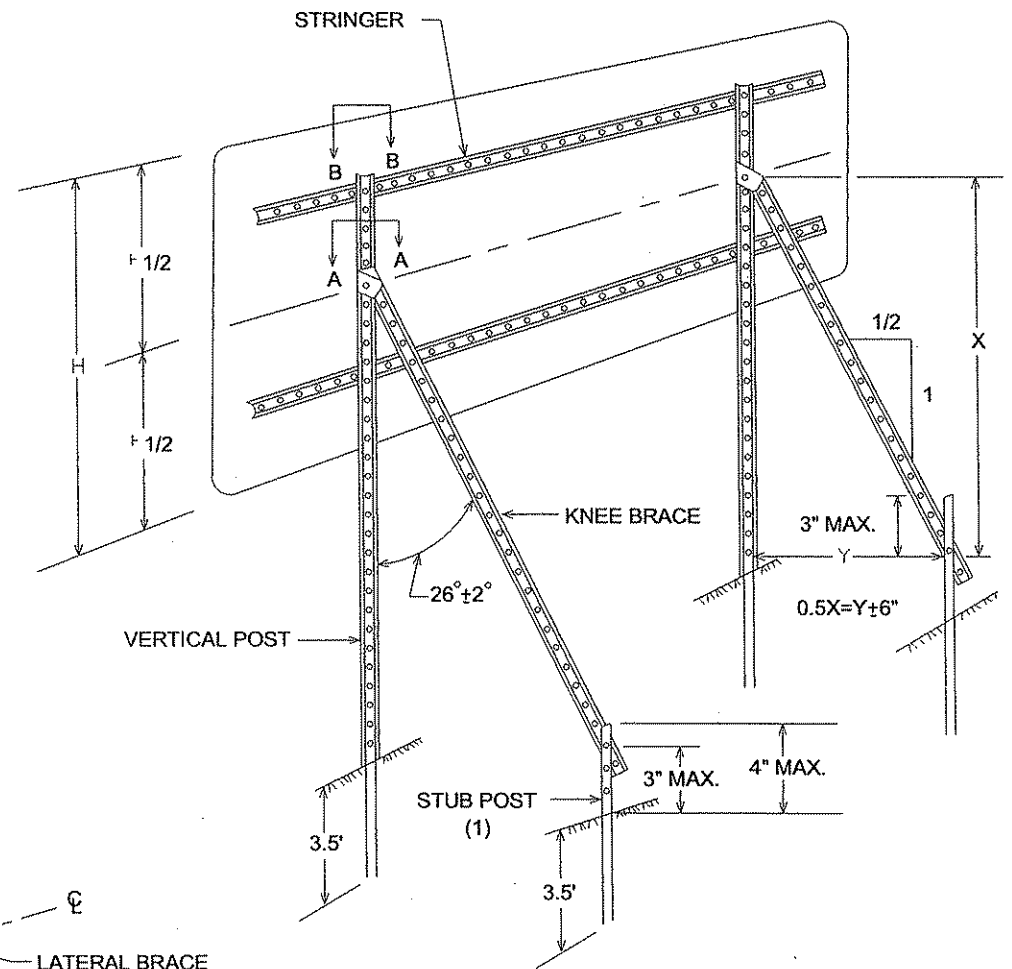

TYPICAL "A-FRAME" INSTALLATION  
TYPE "D" SIGNS

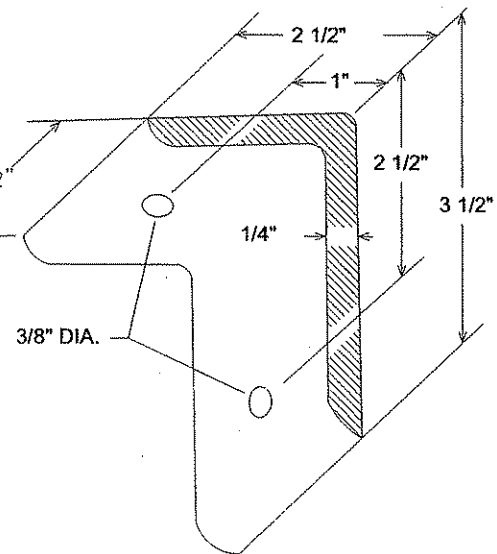

A-FRAME BRACKET

(STEEL MN/DOT 3306 GALVANIZED PER MN/DOT 3394)

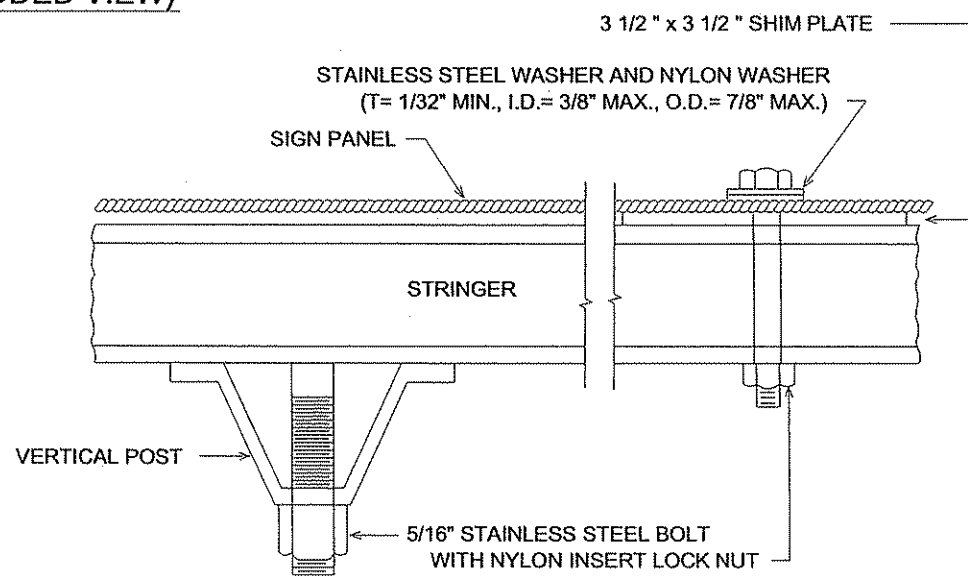

SECTION B-B

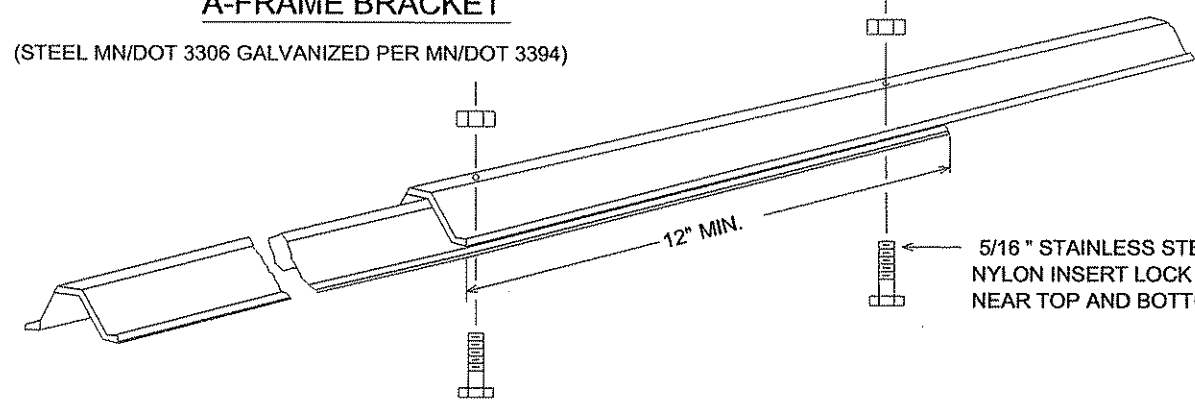

KNEE BRACE SPLICE

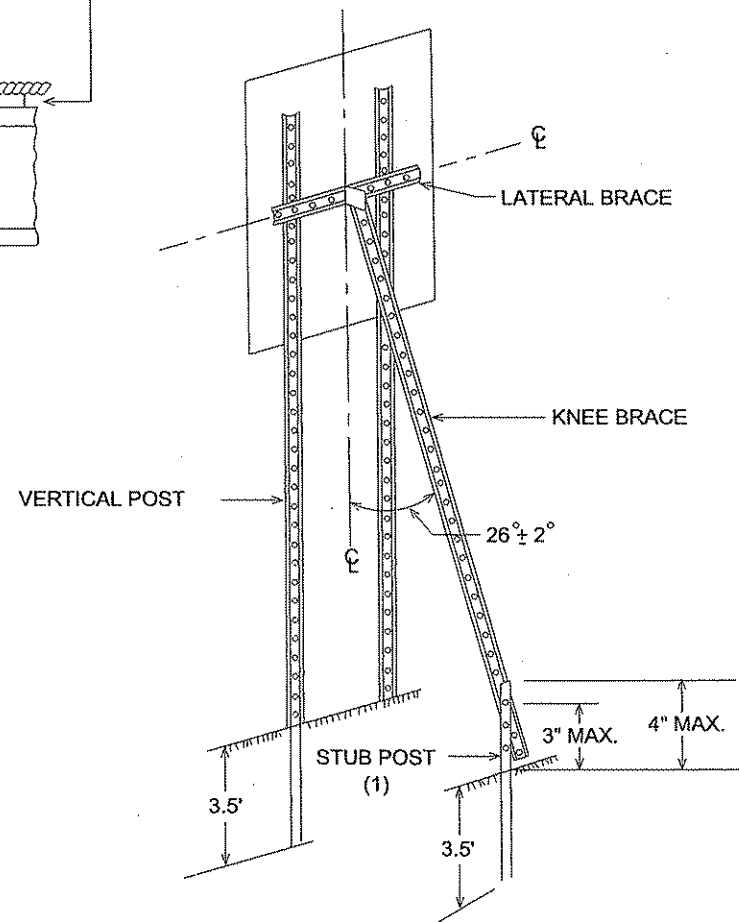

TYPICAL "A-FRAME" INSTALLATION  
TYPE "C" SIGNS

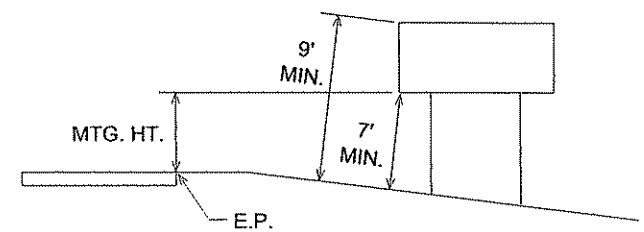

TYPICAL MOUNTING

(1) OFFSET STUB POST 1' TOWARD ROADWAY  
RELATIVE TO VERTICAL POST.

TYPE C & D SIGN  
STRUCTURAL DETAILS

NO	DATE	BY	CKD	APPR	REVISION

I HEREBY CERTIFY THAT THIS PLAN WAS PREPARED BY ME  
OR UNDER MY DIRECT SUPERVISION AND THAT I AM A DULY  
LICENSED PROFESSIONAL ENGINEER UNDER THE LAWS OF  
THE STATE OF MINNESOTA.  
PRINT NAME: ANDREW MITTER  
SIGNATURE: *Andrew Mitter*  
DATE: 3/7/13 LICENSE NO. 42757

DRAWN BY MTH DATE 2-05-13  
DESIGN BY MTH DATE 2-05-13  
CHECKED BY JR DATE 1-21-11



ANOKA COUNTY  
HIGHWAY DEPT.

STATE PROJECT NO. \_\_\_\_\_  
STATE PROJECT NO. \_\_\_\_\_  
STATE PROJECT NO. \_\_\_\_\_  
COUNTY PROJECT NO. 13-13-13

SIGNING & STRIPING DETAILS

Sheet 26 of 27 Sheets

RURAL

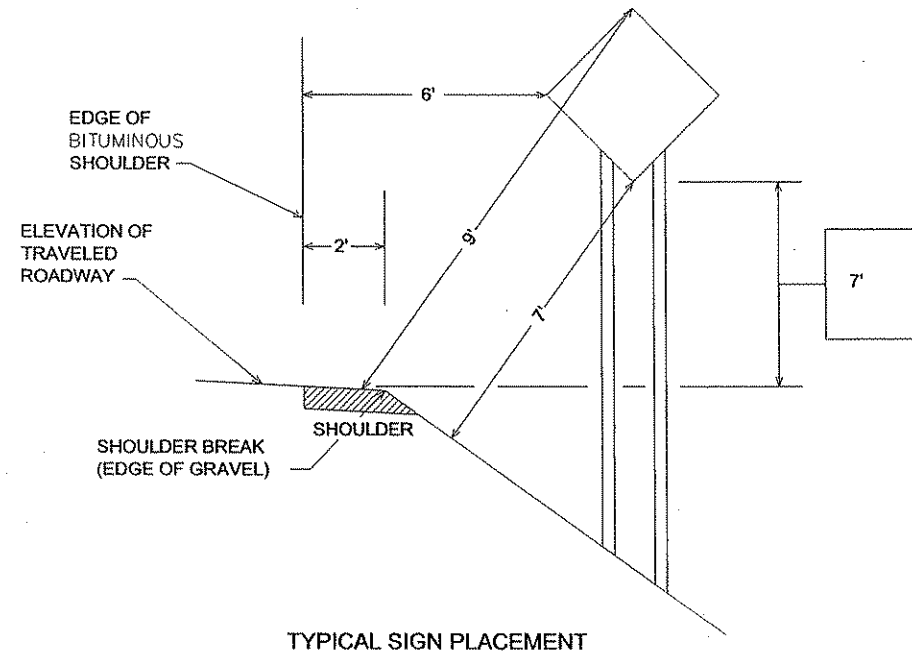

TYPICAL SIGN PLACEMENT

URBAN

- 2' - NARROW BOULEVARD (< 8' WIDE)
- 6' - WIDE BOULEVARD

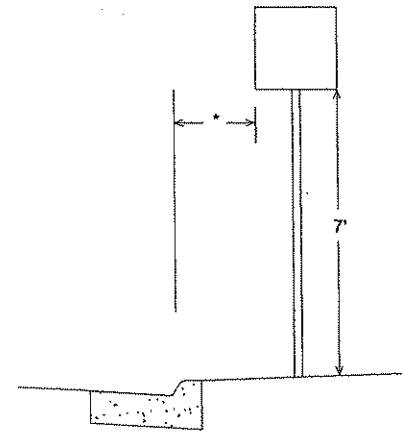

TYPICAL SIGN PLACEMENT

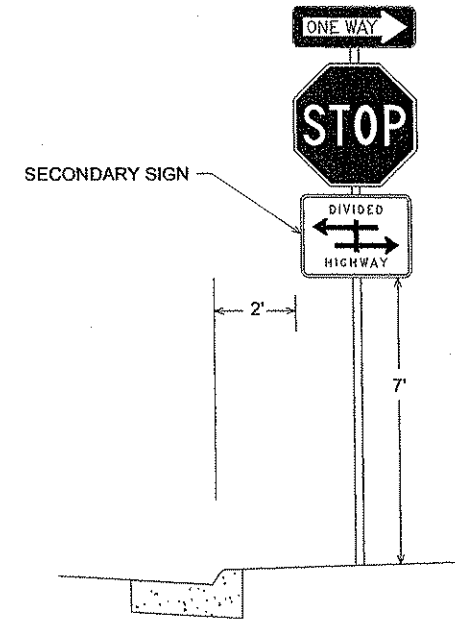

NOTE:

- ALL DIMENSIONS ARE MINIMUMS
- MAINTAIN 2' CLEAR FROM SIGNS TO BITUMINOUS TRAIL

NO	DATE	BY	CKD	APPR	REVISION

I HEREBY CERTIFY THAT THIS PLAN WAS PREPARED BY ME OR UNDER MY DIRECT SUPERVISION AND THAT I AM A DULY LICENSED PROFESSIONAL ENGINEER UNDER THE LAWS OF THE STATE OF MINNESOTA.  
 PRINT NAME: ANDREW WITTER  
 SIGNATURE: *Andrew Witter*  
 DATE: 3/7/13 LICENSE NO. 42757

DRAWN BY MTH DATE 2-05-13  
 DESIGN BY MTH DATE 2-05-13  
 CHECKED BY JR DATE 02-XX-12



ANOKA COUNTY  
 HIGHWAY DEPT.

STATE PROJECT NO. \_\_\_\_\_  
 STATE PROJECT NO. \_\_\_\_\_  
 STATE PROJECT NO. \_\_\_\_\_  
 COUNTY PROJECT NO. 13-13-13

SIGNING & STRIPING DETAILS

Sheet 27 of 27 Sheets