

PLAN SYMBOLS

- COUNTY LINE _____
- TOWNSHIP OR RANGE LINE _____
- SECTION LINE _____
- QUARTER LINE _____
- SIXTEENTH LINE _____
- RIGHT OF WAY LINE _____
- SLOPE EASEMENT _____
- EXISTING RIGHT OF WAY _____
- PROPERTY LINE _____
- CORPORATE OR CITY LIMITS _____
- RETAINING WALL _____
- RAILROAD _____
- RAILROAD RIGHT OF WAY _____
- RIVER OR CREEK _____
- DRAINAGE DITCH _____
- CULVERT _____
- DROP INLET _____
- GUARD RAIL _____
- BARBED WIRE FENCE _____
- WOVEN WIRE FENCE _____
- CHAIN LINK FENCE _____
- WOOD FENCE _____
- STONE WALL OR FENCE _____
- HEDGE _____

- LOWLAND _____
- TIMBER _____
- ORCHARD _____
- BRUSH _____
- NURSERY _____
- CATTLE GUARD _____
- OVERPASS (Highway Over) _____
- UNDERPASS (Highway Under) _____
- BRIDGE _____
- BUILDING (One Story Frame) _____
- F-FRAME C-CONCRETE _____
- S-STONE T-TILE _____
- B-BRICK ST-STUCCO _____
- RAILROAD CROSSING BELL _____
- RAILROAD CROSSING GATE _____
- MANHOLE _____
- CATCH BASIN _____
- FIRE HYDRANT _____
- CAST IRON MONUMENT _____
- IRON PIN _____
- GRAVEL PIT _____
- SAND PIT _____
- BORROW PIT _____
- ROCK QUARRY _____

UTILITY SYMBOLS

- POWER POLE LINE _____
- TELEPHONE OR TELEGRAPH POLE LINE _____
- JOINT TELEPHONE & POWER ON POWER POLES _____
- ON TELEPHONE POLES _____
- ANCHOR _____
- STEEL TOWER _____
- STREET LIGHT _____
- PEDESTAL (Cable Terminal) _____
- GAS MAIN _____
- WATERMAIN _____
- TELEPHONE CABLE IN CONDUIT _____
- ELECTRIC CABLE IN CONDUIT _____
- TELEPHONE MANHOLE _____
- ELECTRIC MANHOLE _____
- BURIED TELEPHONE CABLE _____
- BURIED ELECTRIC CABLE _____
- SEWER (Sanitary or Storm) _____
- SEWER MANHOLE _____

SCALES

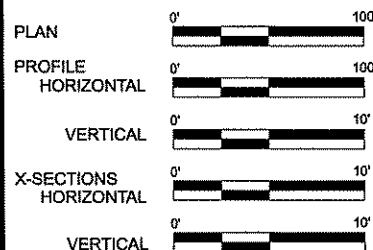

MINNESOTA DEPARTMENT OF TRANSPORTATION ANOKA COUNTY

CONSTRUCTION PLAN FOR 2" BITUMINOUS OVERLAY, AGGREGATE SHOULDERING

LOCATED ON C.S.A.H.17 BETWEEN 1650' N OF CSAH 116 AND CSAH 18

STATE PROJ. NO. 10-17-17

C.S.A.H. 17

GROSS LENGTH	18819 FEET	3.564 MILES
BRIDGES-LENGTH	0.00 FEET	0.000 MILES
EXCEPTIONS-LENGTH	0.00 FEET	0.000 MILES
NET LENGTH	18819 FEET	3.564 MILES

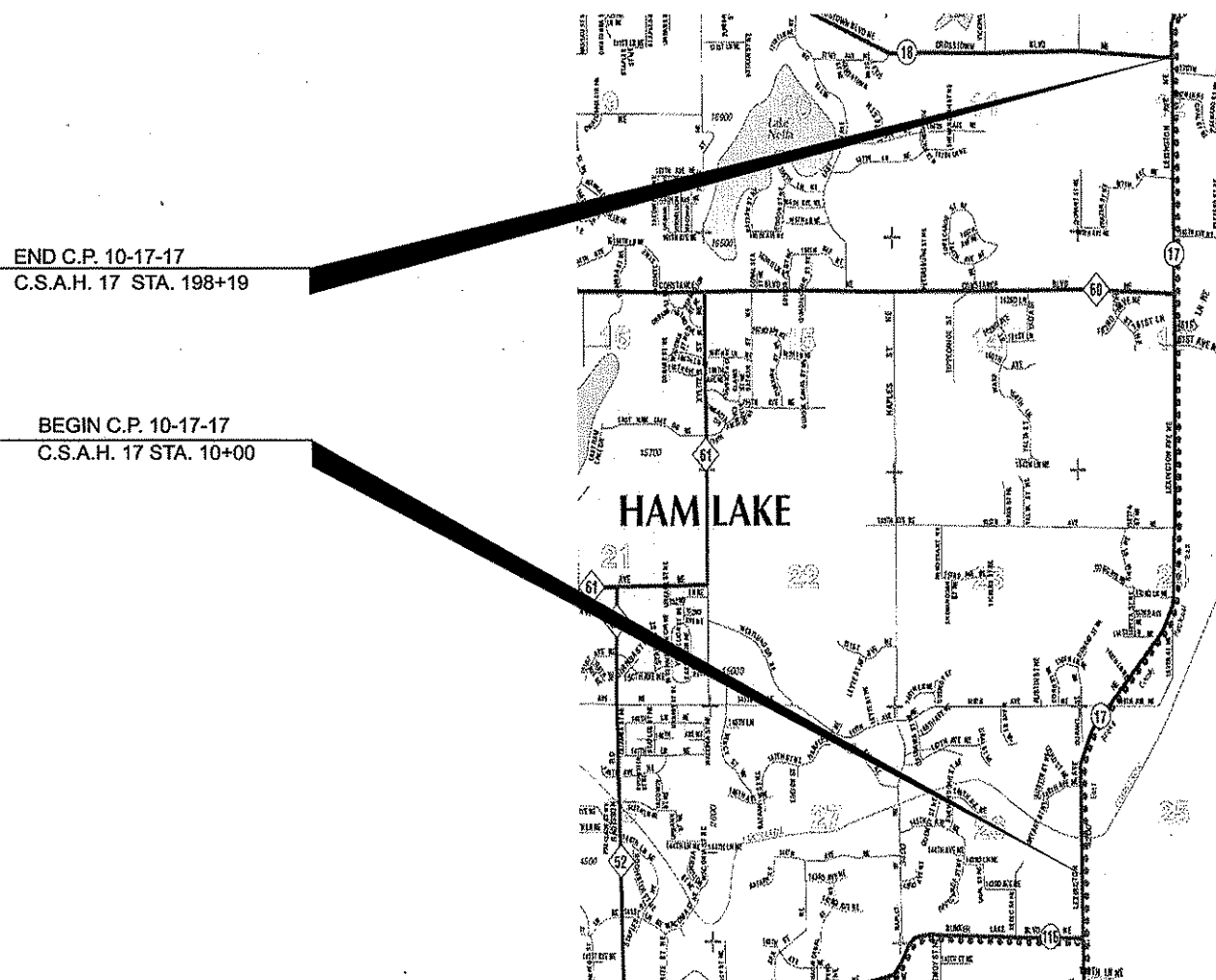

END C.P. 10-17-17
C.S.A.H. 17 STA. 198+19

BEGIN C.P. 10-17-17
C.S.A.H. 17 STA. 10+00

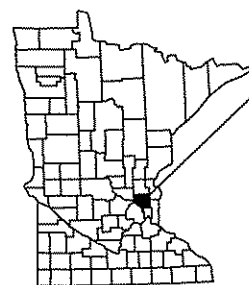

PROJECT LOCATION

CITY OF HAM LAKE
ANOKA COUNTY
MN/DOT TRANSPORTATION DISTRICT - METRO
SECTIONS 12, 13, & 24
TOWNSHIP 32 NORTH
RANGE 23 WEST

MINN. PROJ. NO. _____

GOVERNING SPECIFICATIONS

THE 2005 EDITION OF THE MINNESOTA DEPARTMENT OF TRANSPORTATION "STANDARD SPECIFICATIONS FOR CONSTRUCTION" SHALL GOVERN. ALL TRAFFIC CONTROL DEVICES SHALL CONFORM AND BE INSTALLED IN ACCORDANCE TO THE "MINNESOTA MANUAL ON UNIFORM TRAFFIC CONTROL DEVICES" (MNMUTCD), AND PAR VI, "FIELD MANUAL FOR TEMPORARY TRAFFIC CONTROL ZONE LAYOUTS."

INDEX

SHEET NO.	DESCRIPTION
1	TITLE SHEET
2	STATEMENT OF ESTIMATED QUANTITIES
3, 4	TYPICAL SECTIONS
5, 6	MISCELLANEOUS DETAILS
7-13	GENERAL LAYOUT
14-20	SIGNING & STRIPING PLAN, TAB, & DETAILS

THIS PLAN CONTAINS 20 SHEETS

Approved 3/26/2010 
ANOKA COUNTY ENGINEER

NO	DATE	BY	CKD	APPR	REVISION

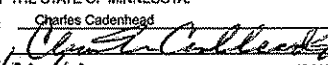
I HEREBY CERTIFY THAT THIS PLAN WAS PREPARED BY ME OR UNDER MY DIRECT SUPERVISION AND THAT I AM A DULY LICENSED PROFESSIONAL ENGINEER UNDER THE LAWS OF THE STATE OF MINNESOTA.
PRINT NAME: Charles Cadenhead
SIGNATURE: 
DATE: 3/26/10 LICENSE NO. 40416

DRAWN BY: SRK DATE: 1/22/2010
DESIGN BY: SRK DATE: 1/22/2010
CHECKED BY: _____ DATE: _____

 ANOKA COUNTY
HIGHWAY DEPT.

COUNTY PROJECT NO. 10-17-17

TITLE SHEET
Sheet 1 of 20 Sheets

STATEMENT OF ESTIMATED QUANTITIES					10-17-17
ITEM NO.	ITEM	NOTE NO.	UNIT	TOTAL EST. QUANT.	
2021.501	MOBILIZATION		LUMP SUM	1	
2104.505	REMOVE CONCRETE DRIVEWAY PAVEMENT		SQ YDS	39	
2104.511	SAWING CONCRETE PAVEMENT (FULL DEPTH)		LIN FT	10	
2118.501	AGGREGATE SURFACING CLASS 5 (DRIVEWAYS)	1	TON	170	
2221.501	AGGREGATE SHOULDERING CLASS 5	1	TON	596	
2232.501	MILL BITUMINOUS SURFACE (2") (JOINTS)	3	SQ YD	316	
2357.502	BITUMINOUS MATERIAL FOR TACK COAT		GALLON	2683	
2360.501	TYPE SP 12.5 WEARING COURSE (2" SPWEB440B) (4,B)	1	TON	6169	
2360.501	TYPE SP 12.5 WEARING COURSE (2" SPWEB440B) (4,B)- -STREET APPROACHES	1	TON	270	
2531.507	6" CONCRETE DRIVEWAY PAVEMENT		SQ YD	39	
2540.602	INSTALL MAIL BOX SUPPORT		EACH	37	
2563.601	TRAFFIC CONTROL	4,6	LUMP SUM	1	
2581.501	REMOVABLE PREFORMED PLASTIC MARKING	2	LIN FT	1506	
2582.502	4" SOLID LINE WHITE - EPOXY	5	LIN FT	36303	
2582.502	4" BROKEN LINE WHITE - EPOXY	5	LIN FT	40	
2582.502	4" BROKEN LINE YELLOW - EPOXY	5	LIN FT	3380	
2582.502	4" SOLID LINE YELLOW - EPOXY	5	LIN FT	3973	
2582.502	4" DOUBLE SOLID LINE YELLOW - EPOXY	5	LIN FT	3052	

NOTES	
1	TRUCKING, PLACEMENT AND COMPACTION INCIDENTAL TO ITEM.
2	TO BE PLACED PRIOR TO LEAVING SITE AT END OF PAVING DAY.
3	MILL JOINT LOCATIONS & MILL AREAS ARE TO BE FIELD VARIFIED BY ON-SITE INSPECTOR.
4	ALL TRAFFIC CONTROL METHODS SHALL CONFORM TO THE MINNESOTA MANUAL ON UNIFORM TRAFFIC CONTROL DEVICES (MMURCD)
5	STRIPING TO BE INPLACE WITHIN 72 HOURS OF FINAL MAINLINE PAVING.
6	DO NOT PASS, PASS WITH CARE, NO CENTER STRIPE, AND BUMP/BUMP AHEAD SIGNS TO BE INPLACE DURING OVERLAY OPERATIONS.

BASIS OF PLANNED QUANTITIES		
2221.501	AGGREGATE SHOULDERING CLASS 5	CU YDS * 1.8 = TONS
2357.502	BITUMINOUS MATERIAL FOR TACK COAT	.05 GAL / SQ YD
2360.501	TYPE SP 12.5 WEARING COURSE (2" SPWEB440B) (4,B)- -MAINLINE WEAR & ST. APPROACHES	115 LBS/SQ YD/IN THICKNESS
2581.501	REMOVABLE PREFORMED PLASTIC MARKING	4' AT 50' INTERVALS FOR SKIPS

STANDARD DETAIL PLATES	
PLATE NO.	DESCRIPTION
80001	STANDARD BARRICADES

NO	DATE	BY	CHKD	APPR	REVISION
NAME: P:\10-01-00\CSAH_17_(149-Crosstown)\Plan2 Seq.dgn					
3/22/2010 7:07:57 AM					

I HEREBY CERTIFY THAT THIS PLAN WAS PREPARED BY ME OR UNDER MY DIRECT SUPERVISION AND THAT I AM A DULY LICENSED PROFESSIONAL ENGINEER UNDER THE LAWS OF THE STATE OF MINNESOTA.

PRINT NAME: Charles Cadenhead

SIGNATURE: *Charles Cadenhead*

DATE: 3/22/10 LICENSE NO. 40416

DRAWN BY: SRK DATE: 1/22/2010

DESIGN BY: SRK DATE: 1/22/2010

CHECKED BY: DATE:



ANOKA COUNTY
HIGHWAY DEPT.

COUNTY PROJECT NO. 10-17-17

STATEMENT OF ESTIMATED QUANTITIES
STA 10+00 TO 198+19
Sheet 2 of 20 Sheets

EXISTING TYPICAL SECTION

STA. 10+00 - 198+19

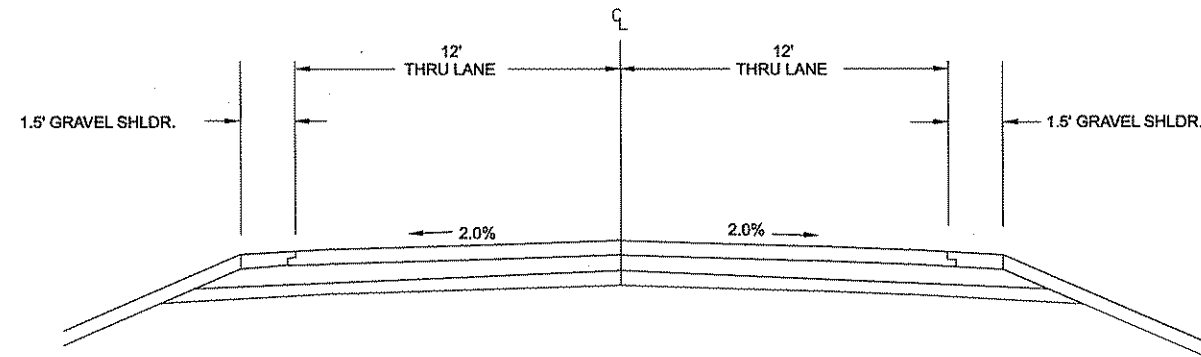

PROPOSED TYPICAL SECTION

STA. 10+00 - 198+19

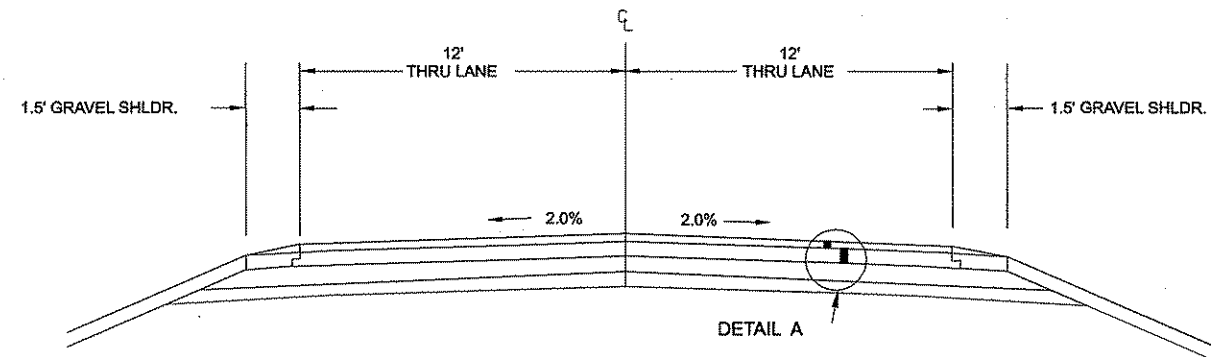

DETAIL A

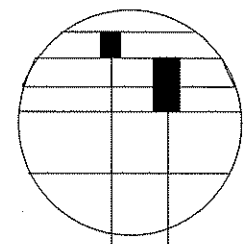

DETAIL A

PAVE 2" TYPE SP 12.5 WEARING
COURSE (SPWEB440B) (4,B)
EXISTING BITUMINOUS

NO	DATE	BY	CHKD	APPR	REVISION

NAME: p:\10-01-00\csah_17_149-crosstown\plan\OVERLAY TEMPLET TYP DETAILS.dgn 8/2/2010 8:19:40 AM

I HEREBY CERTIFY THAT THIS PLAN WAS PREPARED BY ME OR UNDER MY DIRECT SUPERVISION AND THAT I AM A DULY LICENSED PROFESSIONAL ENGINEER UNDER THE LAWS OF THE STATE OF MINNESOTA.

PRINT NAME: Charles Cadenhead

SIGNATURE: *Charles Cadenhead*

DATE: 3/22/10 LICENSE NO. 40416

DRAWN BY SRK DATE 3/22/2010
DESIGN BY SRK DATE 3/22/2010
CHECKED BY _____ DATE _____



ANOKA COUNTY
HIGHWAY DEPT.

COUNTY PROJECT NO. 10-17-17

TYPICAL SECTIONS

Sheet 3 of 20 Sheets

EXISTING TYPICAL SECTION
STA 81+75 - 87+00

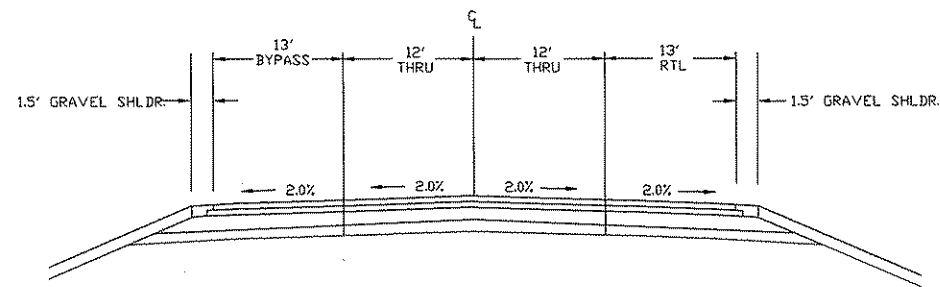

PROPOSED TYPICAL SECTION
STA 81+75 - 87+00

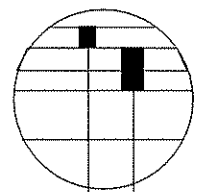
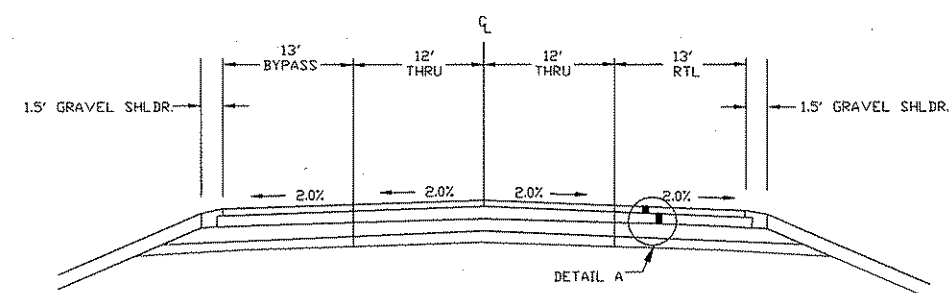

DETAIL A
PAVE 2" TYPE SP 12.5 WEARING
COURSE (SPWEB440B) (4,B)
EXISTING BITUMINOUS

EXISTING TYPICAL SECTION
STA 136+00 - 140+00

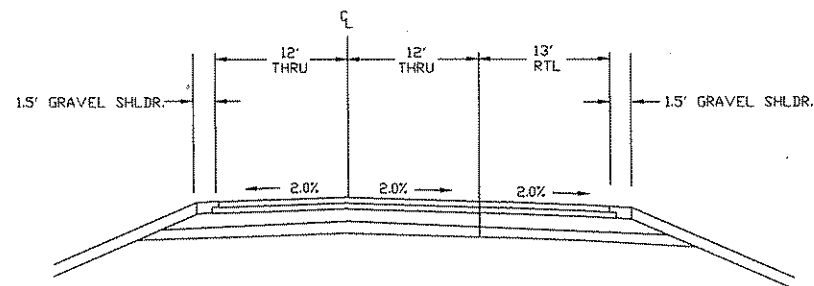

PROPOSED TYPICAL SECTION
STA 136+00 - 140+00

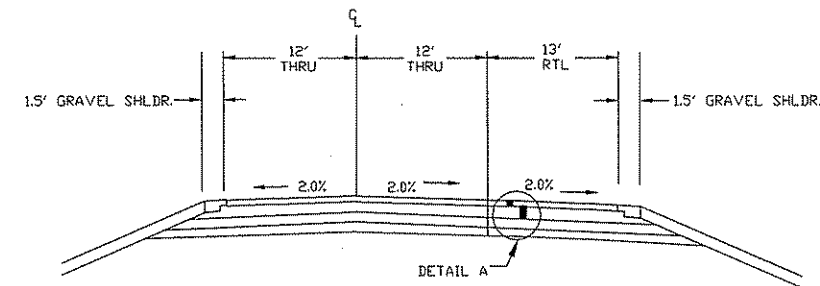

NO	DATE	BY	CKD	APPR	REVISION

NAME: p:\10-01-00\csh_17_149-cross\plan\OVERLAY TEMPLET TYP DETAILS.dwg 8/2/2010 8:19:42 AM

I HEREBY CERTIFY THAT THIS PLAN WAS PREPARED BY ME OR UNDER MY DIRECT SUPERVISION AND THAT I AM A DULY LICENSED PROFESSIONAL ENGINEER UNDER THE LAWS OF THE STATE OF MINNESOTA.
 PRINT NAME: Charles Cadenhead
 SIGNATURE: *Charles Cadenhead*
 DATE: 7/22/10 LICENSE NO. 40416

DRAWN BY: SRK DATE: 1/22/2010
 DESIGN BY: SRK DATE: 1/22/2010
 CHECKED BY: _____ DATE: _____

ANOKA COUNTY
HIGHWAY DEPT.

COUNTY PROJECT NO. 10-17-17

TYPICAL SECTIONS
 Sheet 4 of 20 Sheets

GRAVEL DRIVEWAYS & FIELD ENTRANCES

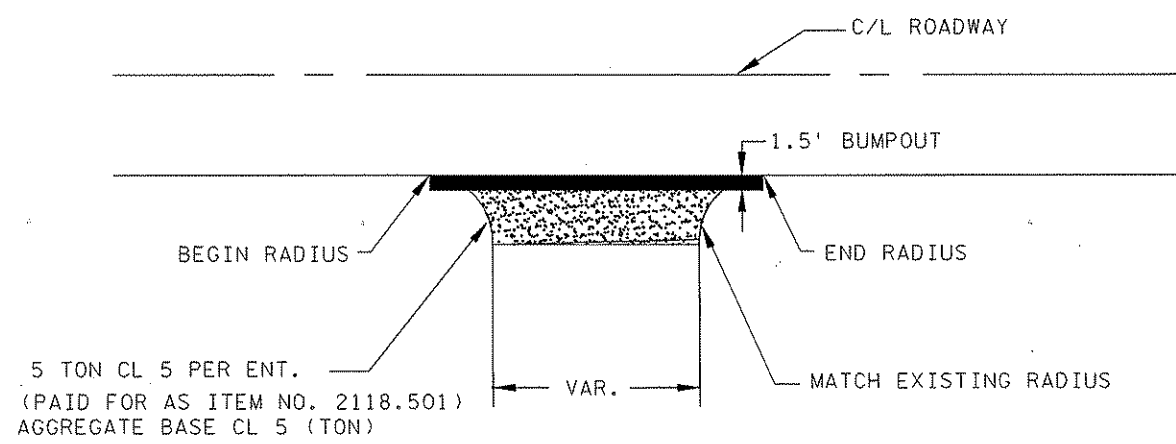

CONCRETE DRIVEWAYS

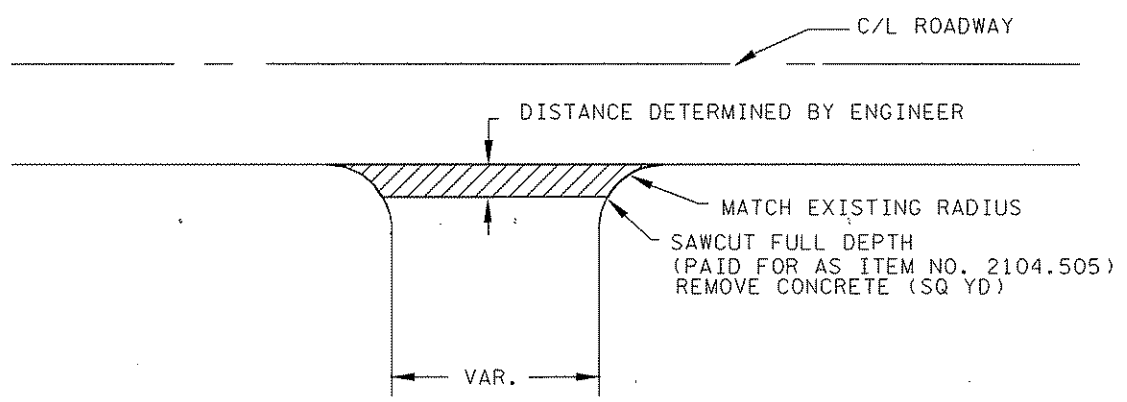

BIT. DRIVEWAYS

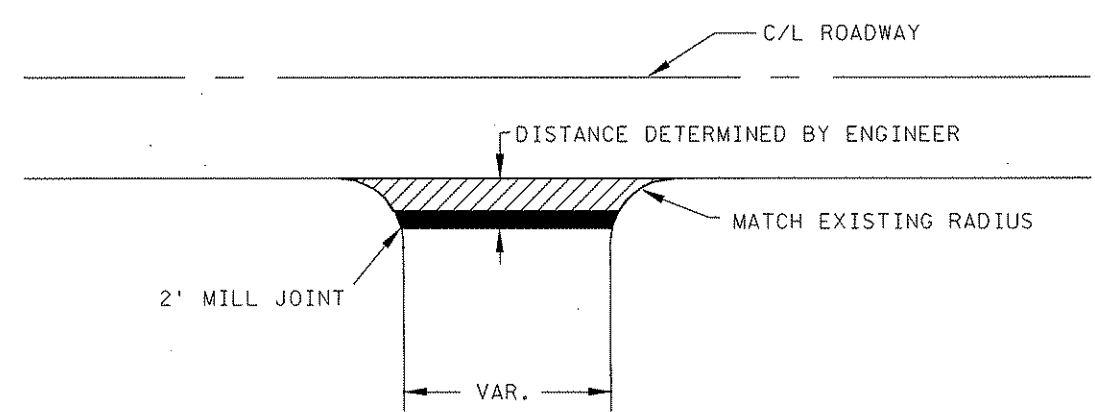

PAVED STREET APPROACHES

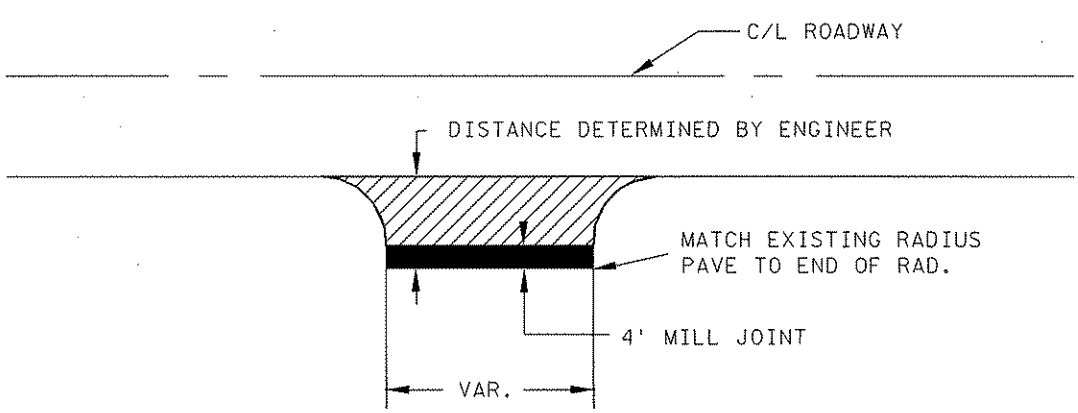

UN-PAVED STREET APPROACHES

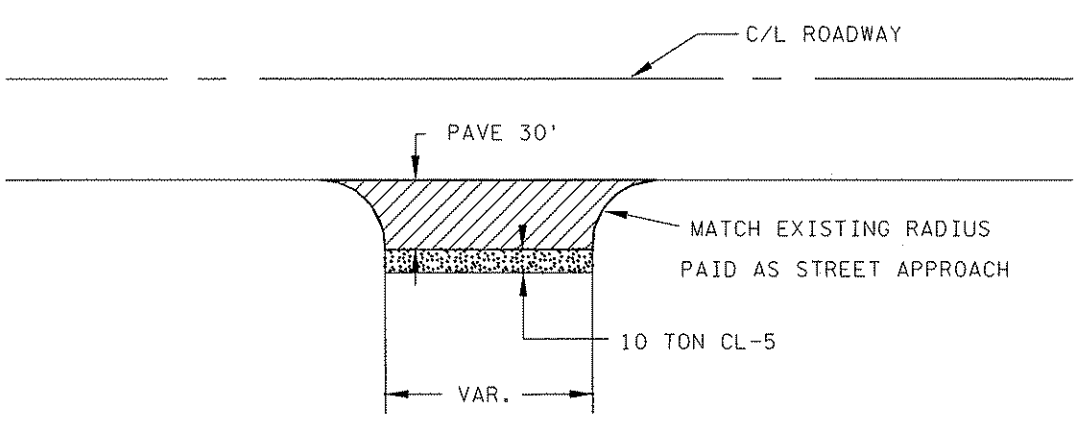

DRIVEWAYS BUMPED OUT AND PAVED WITH MAINLINE PAID AS MAINLINE.
DRIVEWAYS PAVED IN DIFFERENT OPERATION FROM MAIN LINE PAVING PAID AS ST./DR. APPROACH.

NO	DATE	BY	CKD	APPR	REVISION

NAME: p:\10-01-00\csah_17_(149-crosstown)\plan\OVERLAY TEMPLAT TYP DETAILS.dgn/2/2010 8:19:43 AM

I HEREBY CERTIFY THAT THIS PLAN WAS PREPARED BY ME OR UNDER MY DIRECT SUPERVISION AND THAT I AM A DULY LICENSED PROFESSIONAL ENGINEER UNDER THE LAWS OF THE STATE OF MINNESOTA.
PRINT NAME: Charles Cadenhead
SIGNATURE: *Charles Cadenhead*
DATE: 3/26/12 LICENSE NO. 40416

DRAWN BY: SRK DATE: 1/22/2010
DESIGN BY: SRK DATE: 1/22/2010
CHECKED BY: DATE: _____

ANOKA COUNTY
HIGHWAY DEPT.

COUNTY PROJECT NO. 10-17-17

MISC. DETAILS
Sheet 5 of 20 Sheets

PAVED DRIVEWAYS / PAVED STREETS
JOINT DETAILS

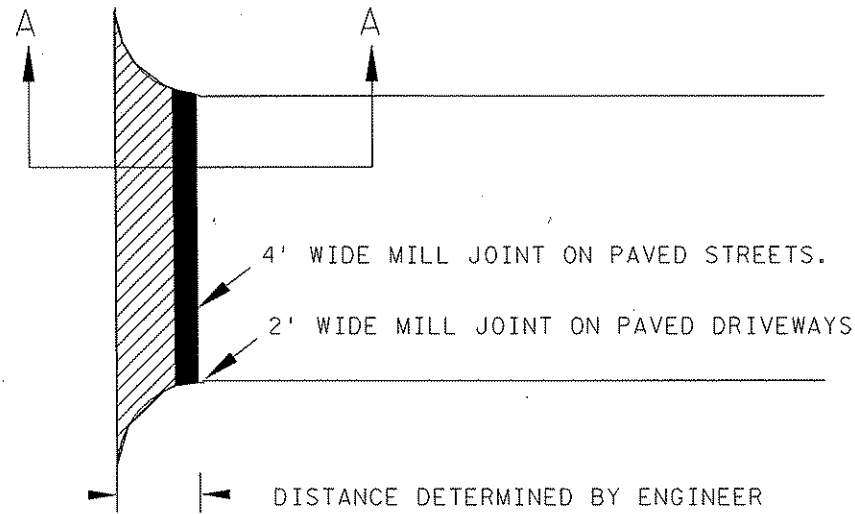

DRIVEWAYS BUMPED OUT AND PAVED WITH MAINLINE, PAID AS MAINLINE.
DRIVEWAYS PAVED IN DIFFERENT OPERATION FROM MAIN LINE PAVING PAID AS ST./DR. APPROACH.
STREETS PAID AS ST./DR. APPROACH.

JOINT DETAILS A - A

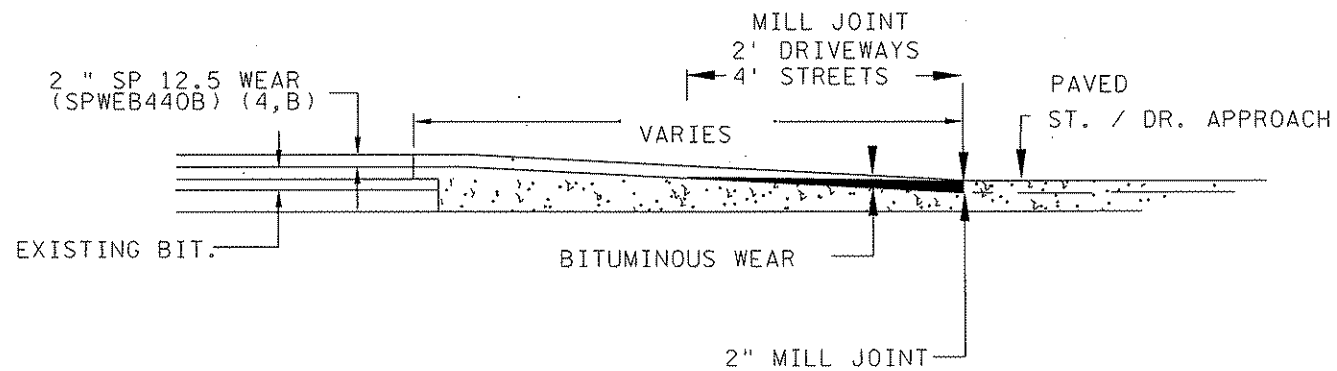

PAID AS STREET APPROACH

10' MILL DETAIL @ STA 10+00 & 198+19

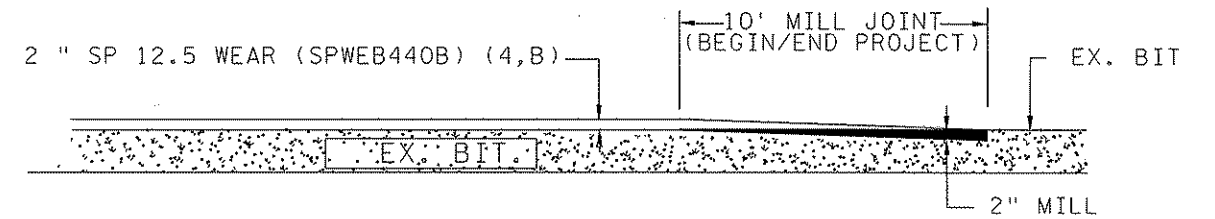

NO	DATE	BY	CKD	APPR	REVISION

NAME: p:\10-01-00\csah_17_149-grosslowm\planOVERLAY TEMPLET TYP DETAILS.dgn 8/2/2010 8:19:41 AM

I HEREBY CERTIFY THAT THIS PLAN WAS PREPARED BY ME OR UNDER MY DIRECT SUPERVISION AND THAT I AM A DULY LICENSED PROFESSIONAL ENGINEER UNDER THE LAWS OF THE STATE OF MINNESOTA.
PRINT NAME: Charles Cadenhead
SIGNATURE: *Charles Cadenhead*
DATE: 3/26/10 LICENSE NO. 40416

DRAWN BY SRK DATE 1/22/2010
DESIGN BY SRK DATE 1/22/2010
CHECKED BY DATE



ANOKA COUNTY
HIGHWAY DEPT.

COUNTY PROJECT NO. 10-17-17

MISC. DETAILS
Sheet 6 of 20 Sheets

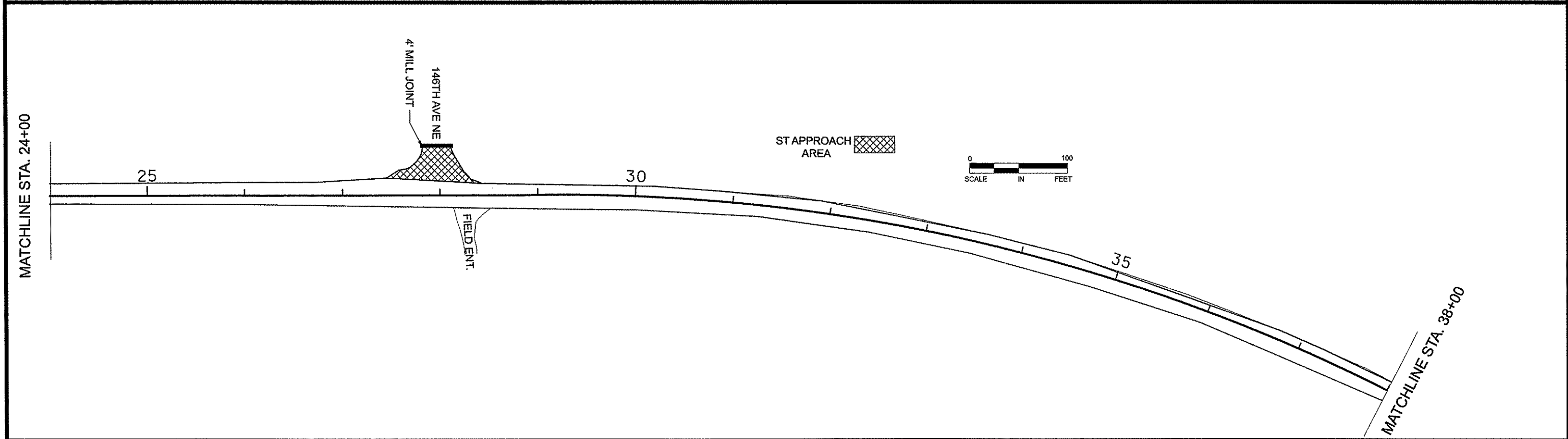
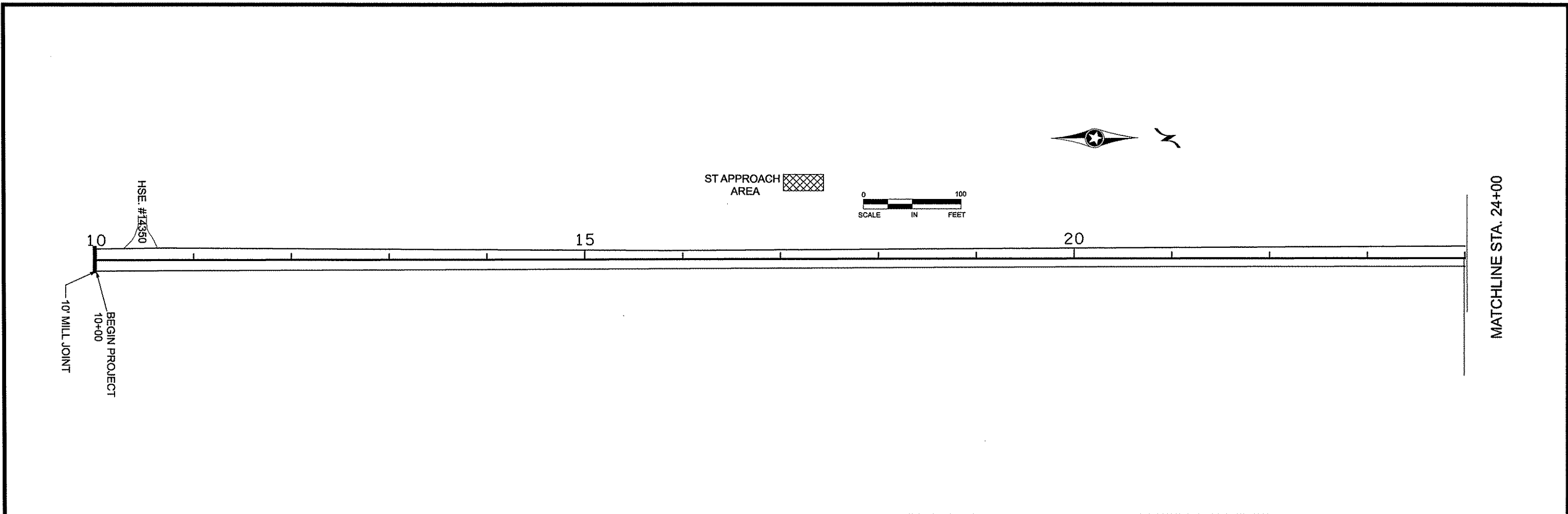

NO	DATE	BY	CHKD	APPR	REVISION

NAME: P:\10-01-00\CSAH_17_(149-Crosstown)\Plan\OVERLAY TEMPLAT PLAN PLAN.dwg 8/28/2010 2:35:20 PM

I HEREBY CERTIFY THAT THIS PLAN WAS PREPARED BY ME OR UNDER MY DIRECT SUPERVISION AND THAT I AM A DULY LICENSED PROFESSIONAL ENGINEER UNDER THE LAWS OF THE STATE OF MINNESOTA.

PRINT NAME: Charles Cadenhead
 SIGNATURE: *Charles Cadenhead*
 DATE: 3/28/10 LICENSE NO. 40418

DRAWN BY: SRK DATE: 1/22/2010
 DESIGN BY: SRK DATE: 1/22/2010
 CHECKED BY: _____ DATE: _____

ANOKA COUNTY
HIGHWAY DEPT.

COUNTY PROJECT NO. 10-17-17

PLAN
 STA 10+00 TO 38+00
 Sheet 7 of 20 Sheets

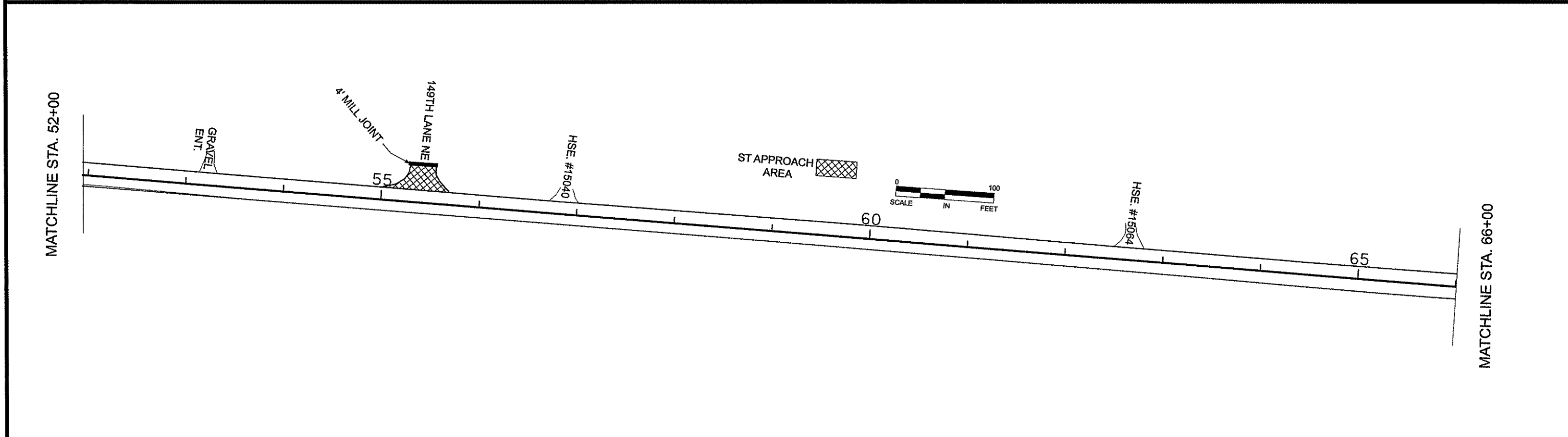
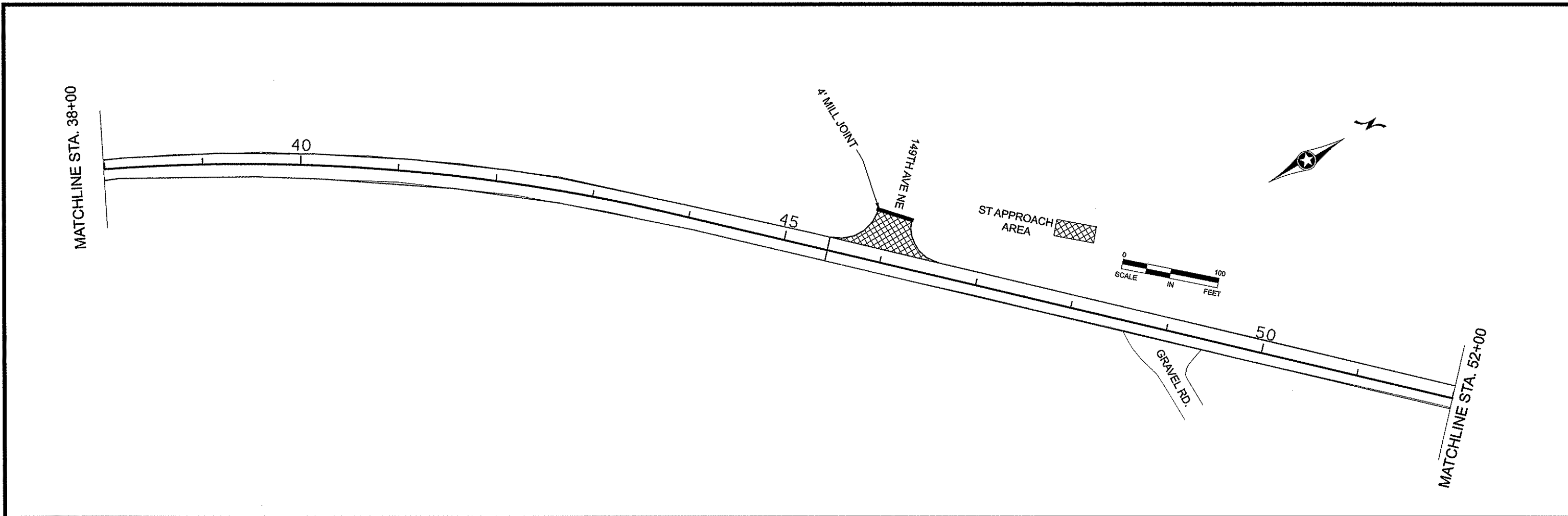

NO	DATE	BY	CHKD	APPR	REVISION

NAME: P:\10-01-00\CSAH_17_(149-Crosstown)\Plan\OVERLAY TEMPLET PLAN PLAN.dwg/26/2010 2:38:00 PM

I HEREBY CERTIFY THAT THIS PLAN WAS PREPARED BY ME OR UNDER MY DIRECT SUPERVISION AND THAT I AM A DULY LICENSED PROFESSIONAL ENGINEER UNDER THE LAWS OF THE STATE OF MINNESOTA.

PRINT NAME: Charles Cadenthead
 SIGNATURE: *Charles Cadenthead*
 DATE: 3/26/10 LICENSE NO. 48416

DRAWN BY: SRK DATE: 1/22/2010
 DESIGN BY: SRK DATE: 1/22/2010
 CHECKED BY: _____ DATE: _____

ANOKA COUNTY
HIGHWAY DEPT.

COUNTY PROJECT NO. 10-17-17

PLAN
 STA 38+00 TO 66+00
 Sheet 8 of 20 Sheets

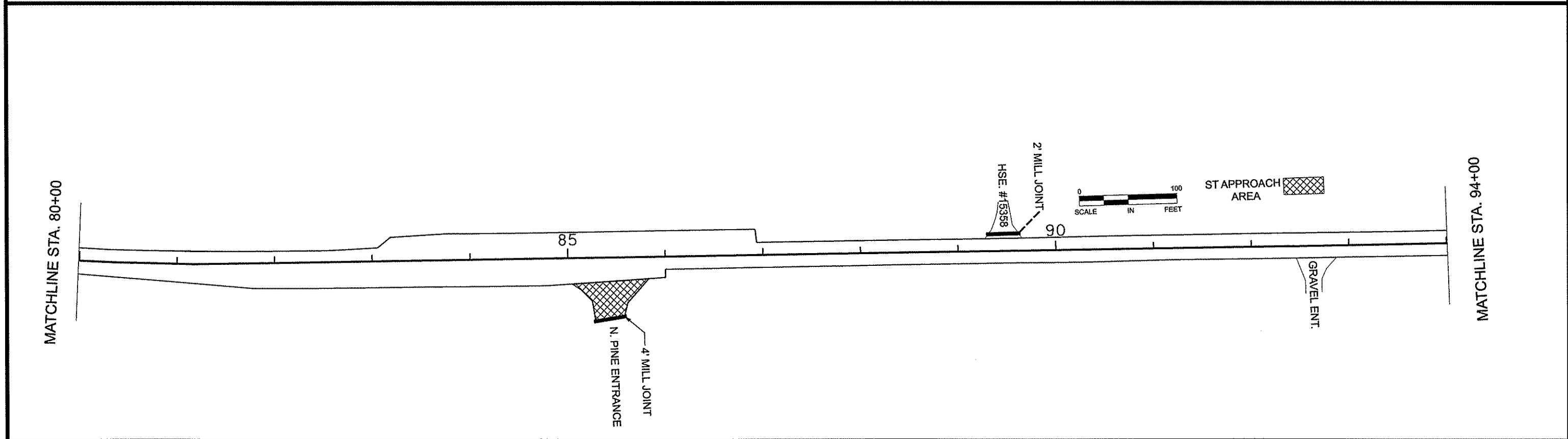
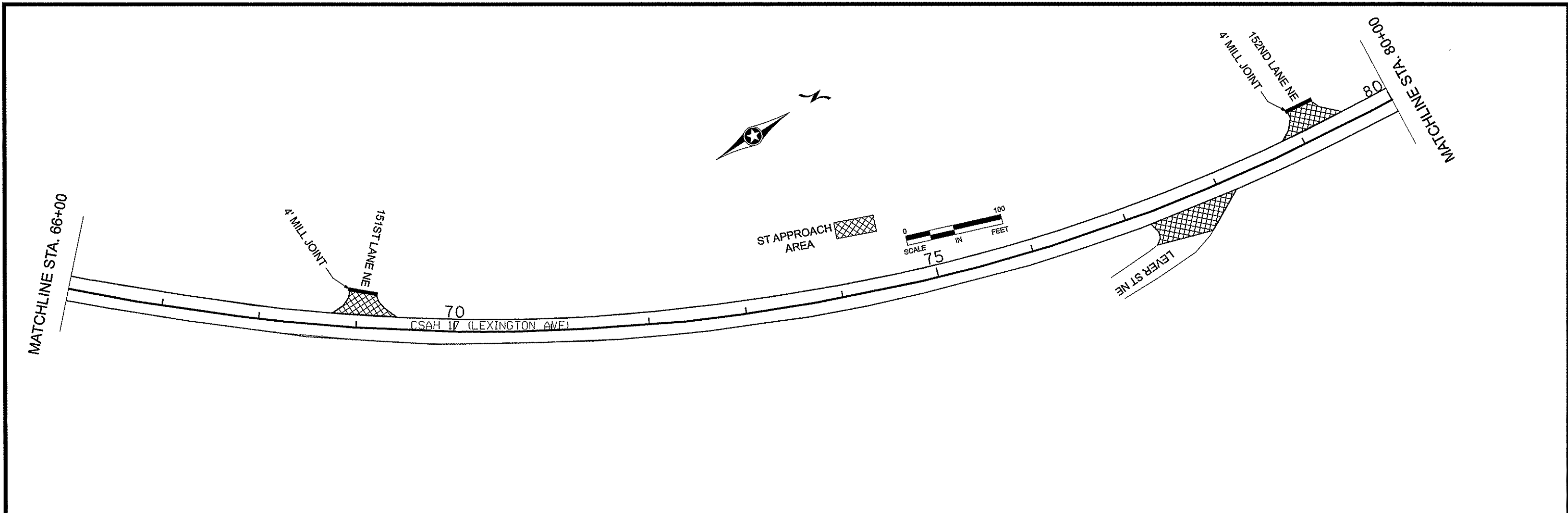

NO	DATE	BY	CKD	APPR	REVISION

NAME: P:\10-01-00\CSAH_17_(149-Crosstown)\Plan\OVERLAY TEMPLET PLAN PLAN.dwg 2/26/2010 2:36:26 PM

I HEREBY CERTIFY THAT THIS PLAN WAS PREPARED BY ME OR UNDER MY DIRECT SUPERVISION AND THAT I AM A DULY LICENSED PROFESSIONAL ENGINEER UNDER THE LAWS OF THE STATE OF MINNESOTA.

PRINT NAME: Charles Cadanhead
 SIGNATURE: *Charles Cadanhead*
 DATE: 3/26/10 LICENSE NO. 40416

DRAWN BY: SRK DATE: 1/22/2010
 DESIGN BY: SRK DATE: 1/22/2010
 CHECKED BY: _____ DATE: _____

 ANOKA COUNTY
 HIGHWAY DEPT.

COUNTY PROJECT NO. 10-17-17

PLAN
 STA 66+00 TO 94+00
 Sheet 9 of 20 Sheets

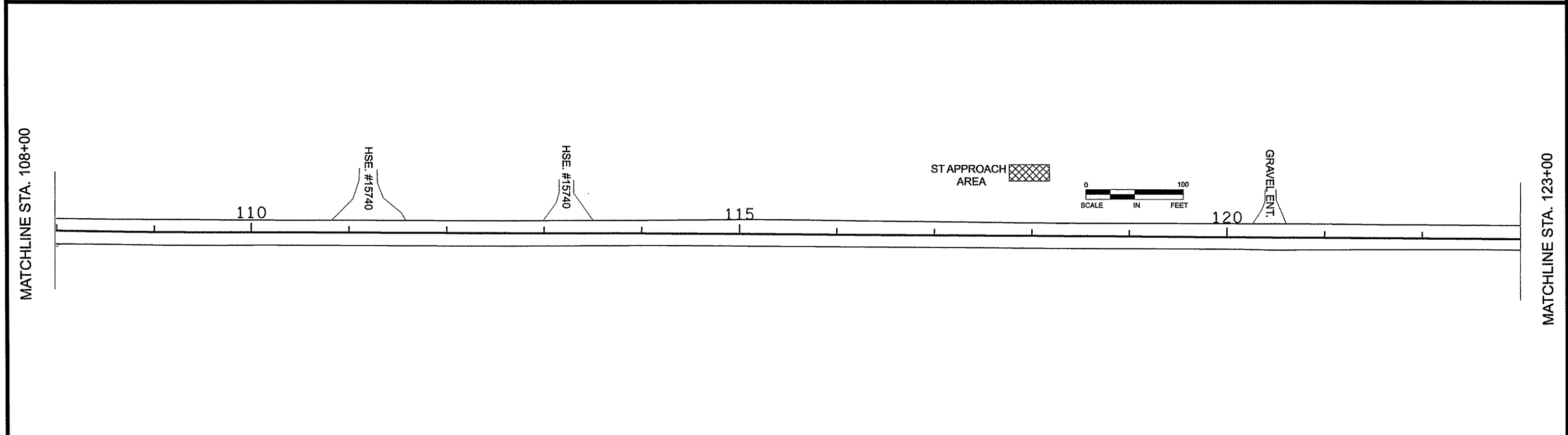
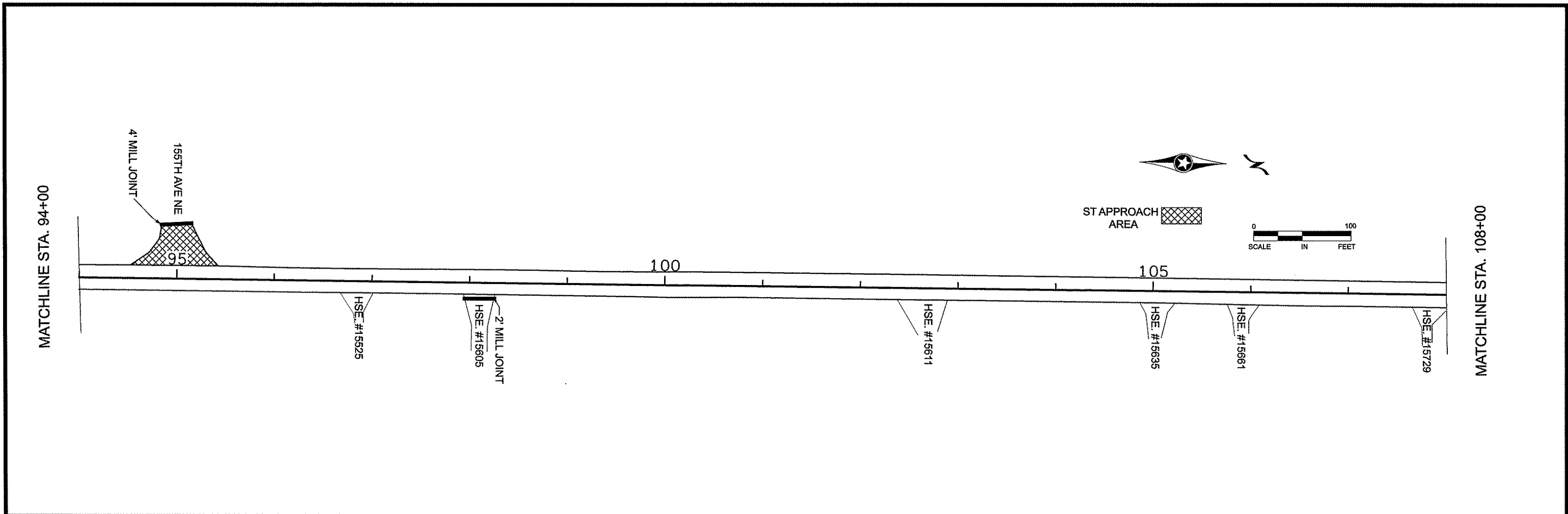

NO	DATE	BY	CKD	APPR	REVISION

NAME: P:\10-01-00\CSAH_17_(149-Crosstown)\Plan\OVERLAY TEMPLET PLAN PLAN.dwg/26/2010 2:37:30 PM

I HEREBY CERTIFY THAT THIS PLAN WAS PREPARED BY ME OR UNDER MY DIRECT SUPERVISION AND THAT I AM A DULY LICENSED PROFESSIONAL ENGINEER UNDER THE LAWS OF THE STATE OF MINNESOTA.

PRINT NAME: Charles Cadenhead

SIGNATURE: *Charles Cadenhead*

DATE: 3/20/10 LICENSE NO. 49416

DRAWN BY: SRK DATE: 1/22/2010

DESIGN BY: SRK DATE: 1/22/2010

CHECKED BY: _____ DATE: _____

ANOKA COUNTY
HIGHWAY DEPT.

COUNTY PROJECT NO. 10-17-17

PLAN
STA 94+00 TO 123+00
Sheet 10 of 20 Sheets

MATCHLINE STA. 123+00

MATCHLINE STA. 138+00

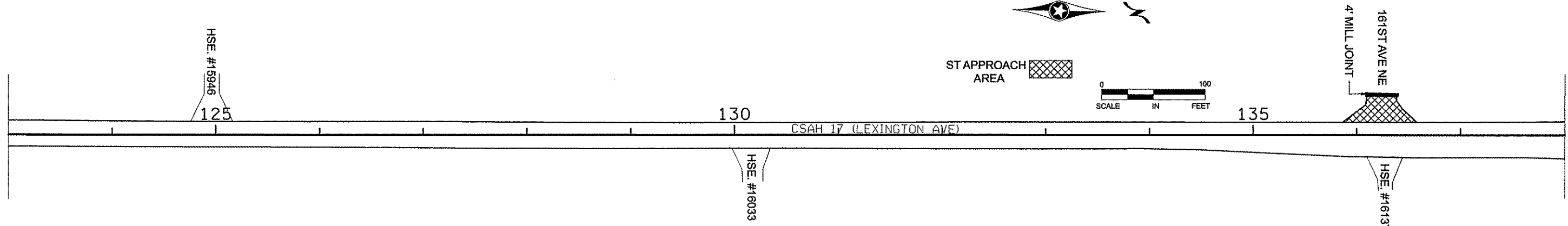

MATCHLINE STA. 138+00

MATCHLINE STA. 153+00

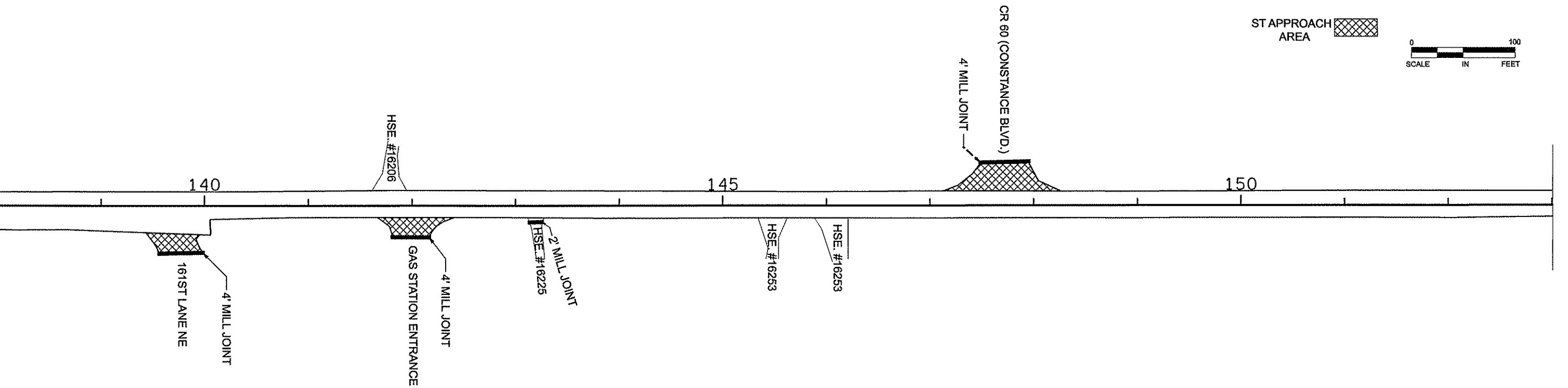

NO	DATE	BY	CKD	APPR	REVISION

NAME: P:\10-01-00\CSAH_17_(149-Crosstown)\Plan\OVERLAY TEMPLAT PLAN PLAN.dwg 2/26/2010 2:38:03 PM

I HEREBY CERTIFY THAT THIS PLAN WAS PREPARED BY ME OR UNDER MY DIRECT SUPERVISION AND THAT I AM A DULY LICENSED PROFESSIONAL ENGINEER UNDER THE LAWS OF THE STATE OF MINNESOTA.

PRINT NAME: Charles Cadenhead

SIGNATURE: *Charles Cadenhead*

DATE: 2/26/10 LICENSE NO. 40416

DRAWN BY: SRK DATE: 1/22/2010

DESIGN BY: SRK DATE: 1/22/2010

CHECKED BY: _____ DATE: _____



ANOKA COUNTY
HIGHWAY DEPT.

COUNTY PROJECT NO. 10-17-17

PLAN
STA 123+00 TO 153+00
Sheet 11 of 20 Sheets

MATCHLINE STA. 153+00

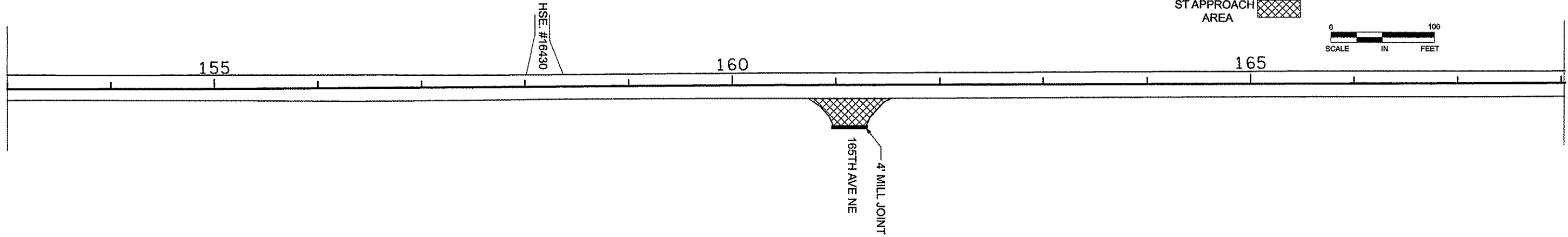

MATCHLINE STA. 168+00

MATCHLINE STA. 168+00

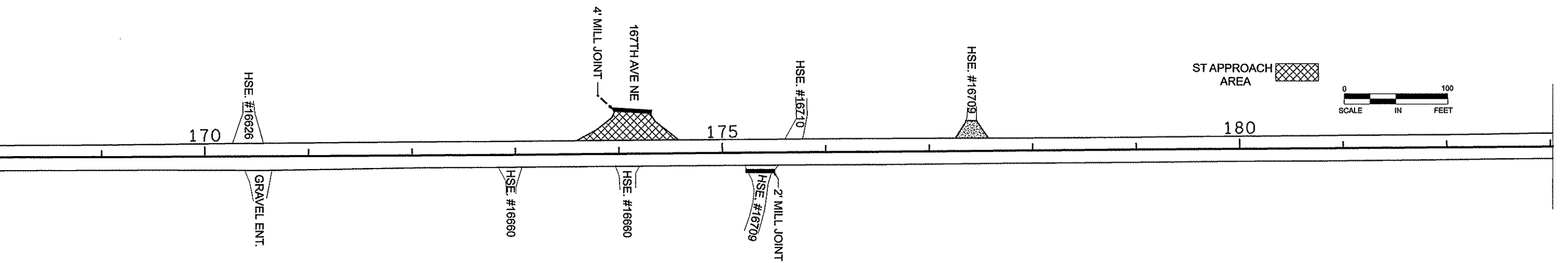

MATCHLINE STA. 183+00

NO	DATE	BY	CKD	APPR	REVISION

NAME: P:\10-01-00\CSAH_17_(149-Crosstown)\Plan\OVERLAY TEMPLET PLAN PLAN.dwg/26/2010 2:38:22 PM

I HEREBY CERTIFY THAT THIS PLAN WAS PREPARED BY ME OR UNDER MY DIRECT SUPERVISION AND THAT I AM A DULY LICENSED PROFESSIONAL ENGINEER UNDER THE LAWS OF THE STATE OF MINNESOTA.

PRINT NAME: Charles Cadenhead
 SIGNATURE: *Charles Cadenhead*
 DATE: 3/28/10 LICENSE NO. 40818

DRAWN BY: SRK DATE: 1/22/2010
 DESIGN BY: SRK DATE: 1/22/2010
 CHECKED BY: _____ DATE: _____



ANOKA COUNTY
HIGHWAY DEPT.

COUNTY PROJECT NO. 10-17-17

PLAN
 STA 153+00 TO 183+00
 Sheet 12 of 20 Sheets

MATCHLINE STA. 183+00

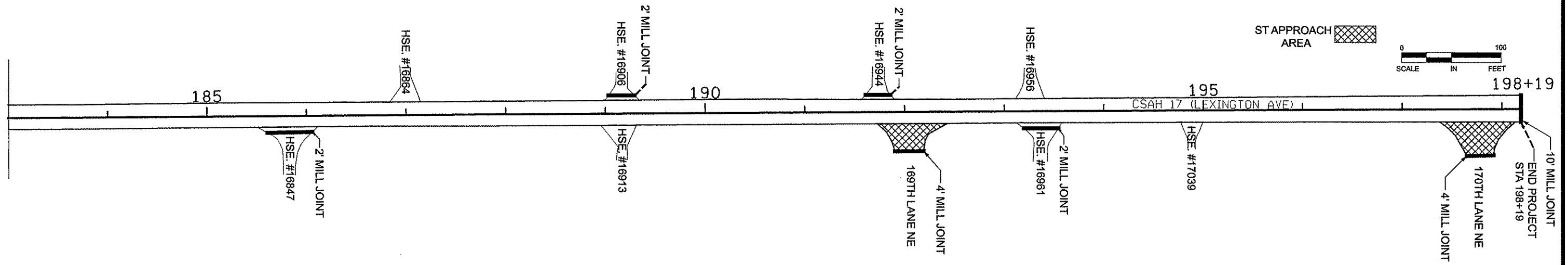

NO	DATE	BY	CKD	APPR	REVISION

NAME: P:\10-01-00\CSAH_17_(149-Crosstown)\Plan\OVERLAY TEMPLET PLAN PLAN.dwg/26/2010 2:36:44 PM

I HEREBY CERTIFY THAT THIS PLAN WAS PREPARED BY ME OR UNDER MY DIRECT SUPERVISION AND THAT I AM A DULY LICENSED PROFESSIONAL ENGINEER UNDER THE LAWS OF THE STATE OF MINNESOTA.

PRINT NAME: Charles Cadenhead

SIGNATURE: *Charles Cadenhead*

DATE: 3/26/10 LICENSE NO. 40418

DRAWN BY SRK DATE 1/22/2010

DESIGN BY SRK DATE 1/22/2010

CHECKED BY DATE



ANOKA COUNTY
HIGHWAY DEPT.

COUNTY PROJECT NO. 10-17-17

PLAN
STA 183+00 TO 198+19
Sheet 13 of 20 Sheets

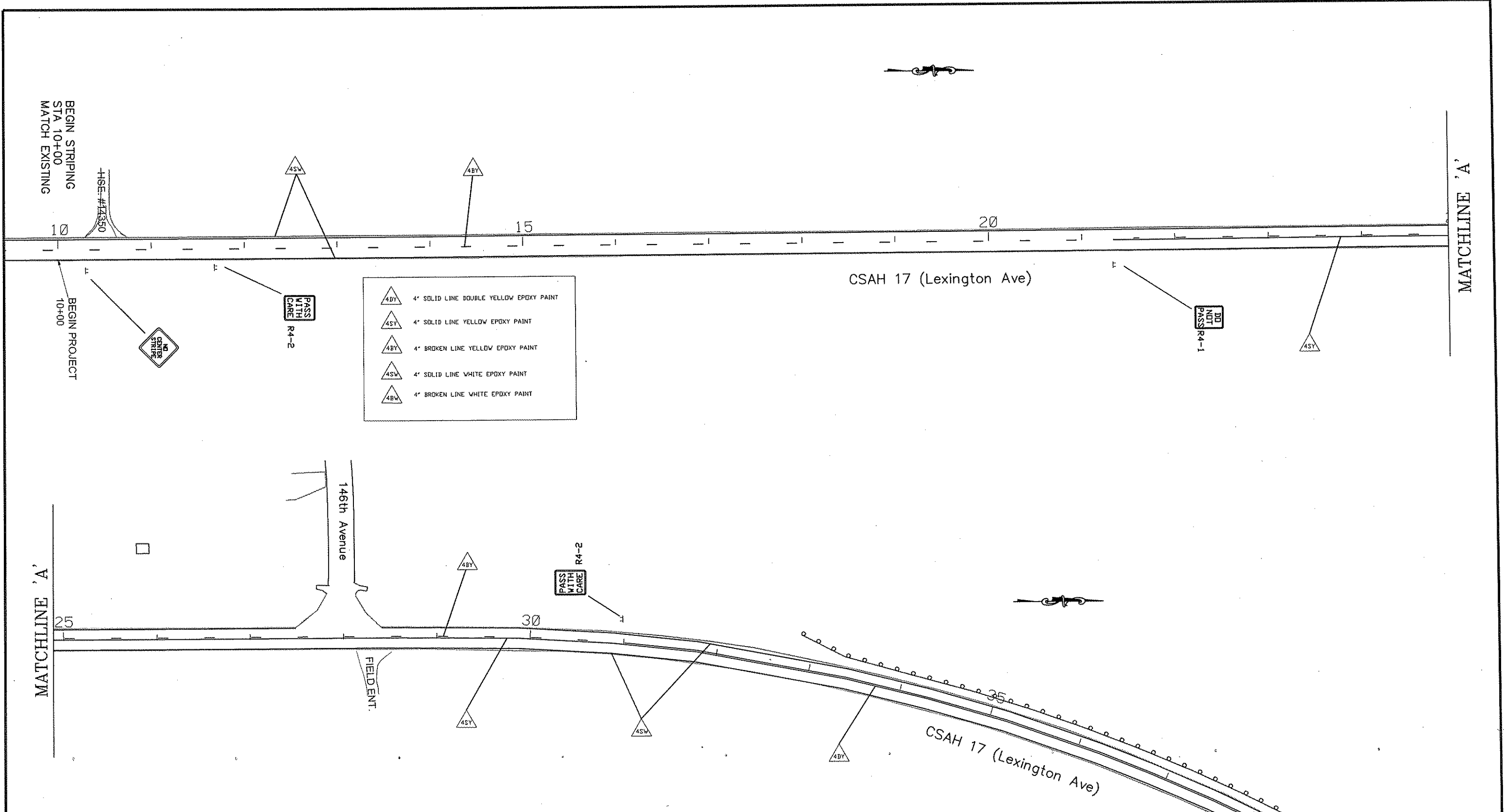

- NOTES:
1. LOCATIONS OF PAVEMENT MARKINGS ARE APPROXIMATE. EXACT LOCATIONS WILL BE DETERMINED IN THE FIELD BY THE ENGINEER.
 2. CONTRACTOR SHALL SUPPLY AND ERECT THE TEMPORARY TRAFFIC CONTROL SIGNS AS SHOWN ON THIS DRAWING FROM THE TIME WORK COMMENCES ON THIS ROADWAY UNTIL THIS ROADWAY IS PERMANENTLY STRIPED. THE TEMPORARY TRAFFIC CONTROL SIGNS SHALL BE PAID FOR AS PART OF TRAFFIC CONTROL LUMP SUM.
 3. ALL PERMANENT STRIPING AND PAVEMENT MESSAGES SHALL BE PLACED WITHIN 72 HOURS OF MAINLINE PAVING.

NO	DATE	BY	CKD	APPR	REVISION

I HEREBY CERTIFY THAT THIS PLAN WAS PREPARED BY ME OR UNDER MY DIRECT SUPERVISION AND THAT I AM A DULY REGISTERED PROFESSIONAL ENGINEER UNDER THE LAWS OF THE STATE OF MINNESOTA.

PRINT NAME: *Charles Cadayhead*
 SIGNATURE: *Charles Cadayhead*
 DATE: *3/26/10* REG. NO. *40416*

DRAWN BY: MTH DATE: 2/23/10
 DESIGN BY: _____ DATE: _____
 CHECKED BY: _____ DATE: _____

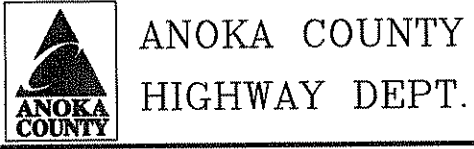

STATE PROJECT NO. _____
 STATE AID PROJECT NO. _____
 STATE AID PROJECT NO. _____
 COUNTY PROJECT NO. 10-17-17



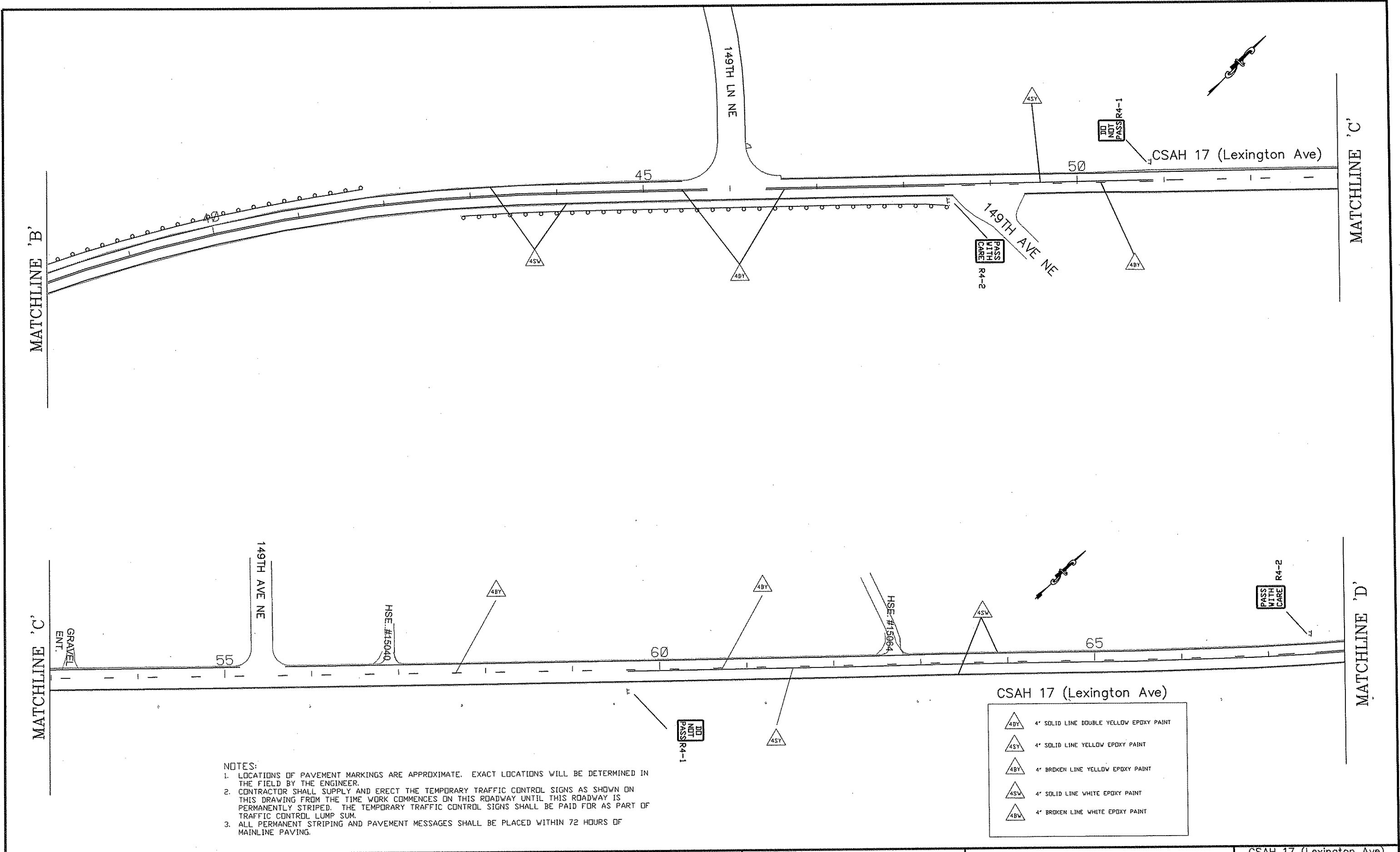

CSAH 17 (Lexington Ave)
 TEMPORARY SIGNING
 PERMANENT STRIPING
 AND PAVEMENT MESSAGES
 Sheet 14 of 20 Sheets

NAME: T:\Traffic\dwg\CSAH 17 (Lexington Av)\from CSAH 32 to CSAH 22.dwg



NOTES:
 1. LOCATIONS OF PAVEMENT MARKINGS ARE APPROXIMATE. EXACT LOCATIONS WILL BE DETERMINED IN THE FIELD BY THE ENGINEER.
 2. CONTRACTOR SHALL SUPPLY AND ERECT THE TEMPORARY TRAFFIC CONTROL SIGNS AS SHOWN ON THIS DRAWING FROM THE TIME WORK COMMENCES ON THIS ROADWAY UNTIL THIS ROADWAY IS PERMANENTLY STRIPED. THE TEMPORARY TRAFFIC CONTROL SIGNS SHALL BE PAID FOR AS PART OF TRAFFIC CONTROL LUMP SUM.
 3. ALL PERMANENT STRIPING AND PAVEMENT MESSAGES SHALL BE PLACED WITHIN 72 HOURS OF MAINLINE PAVING.

CSAH 17 (Lexington Ave)

-  4" SOLID LINE DOUBLE YELLOW EPOXY PAINT
-  4" SOLID LINE YELLOW EPOXY PAINT
-  4" BROKEN LINE YELLOW EPOXY PAINT
-  4" SOLID LINE WHITE EPOXY PAINT
-  4" BROKEN LINE WHITE EPOXY PAINT

NO	DATE	BY	CKD	APPR	REVISION

NAME: T:\Traffic\dwg\CSAH 17 (Lexington Av)\from CSAH 32 to CSAH 22.dwg

I HEREBY CERTIFY THAT THIS PLAN WAS PREPARED BY ME OR UNDER MY DIRECT SUPERVISION AND THAT I AM A DULY REGISTERED PROFESSIONAL ENGINEER UNDER THE LAWS OF THE STATE OF MINNESOTA.
 PRINT NAME: *Charles Copenhagen*
 SIGNATURE: *Charles Copenhagen*
 DATE: 3/26/10 REG. NO. 40416

DRAWN BY: MTH DATE: 2/23/10
 DESIGN BY: _____ DATE: _____
 CHECKED BY: _____ DATE: _____

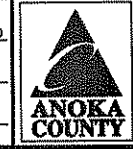

ANOKA COUNTY
 HIGHWAY DEPT.

STATE PROJECT NO. _____
 STATE AID PROJECT NO. _____
 STATE AID PROJECT NO. _____
 COUNTY PROJECT NO. 10-17-17

CSAH 17 (Lexington Ave)
 TEMPORARY SIGNING
 PERMANENT STRIPING
 AND PAVEMENT MESSAGES
 Sheet 15 of 20 Sheets

MATCHLINE 'D'

MATCHLINE 'E'

MATCHLINE 'E'

MATCHLINE 'F'

151ST LN

152ND LN NE

CSAH 17 (Lexington Ave)

LEVER ST NE

CSAH 17 (Lexington Ave)

NOTES:

1. LOCATIONS OF PAVEMENT MARKINGS ARE APPROXIMATE. EXACT LOCATIONS WILL BE DETERMINED IN THE FIELD BY THE ENGINEER.
2. CONTRACTOR SHALL SUPPLY AND ERECT THE TEMPORARY TRAFFIC CONTROL SIGNS AS SHOWN ON THIS DRAWING FROM THE TIME WORK COMMENCES ON THIS ROADWAY UNTIL THIS ROADWAY IS PERMANENTLY STRIPED. THE TEMPORARY TRAFFIC CONTROL SIGNS SHALL BE PAID FOR AS PART OF TRAFFIC CONTROL LUMP SUM.
3. ALL PERMANENT STRIPING AND PAVEMENT MESSAGES SHALL BE PLACED WITHIN 72 HOURS OF MAINLINE PAVING.

	4" SOLID LINE DOUBLE YELLOW EPOXY PAINT
	4" SOLID LINE YELLOW EPOXY PAINT
	4" BROKEN LINE YELLOW EPOXY PAINT
	4" SOLID LINE WHITE EPOXY PAINT
	4" BROKEN LINE WHITE EPOXY PAINT

NO	DATE	BY	CKD	APPR	REVISION

NAME: T:\Traffic\dwg\CSAH 17 (Lexington Av)\from CSAH 32 to CSAH 22.dwg

I HEREBY CERTIFY THAT THIS PLAN WAS PREPARED BY ME OR UNDER MY DIRECT SUPERVISION AND THAT I AM A DULY REGISTERED PROFESSIONAL ENGINEER UNDER THE LAWS OF THE STATE OF MINNESOTA.

PRINT NAME: *Charles Gaden*

SIGNATURE: *Charles Gaden*

DATE: 3/26/10 REG. NO. 40416

DRAWN BY: MTH DATE: 2/23/10

DESIGN BY: DATE: _____

CHECKED BY: DATE: _____



ANOKA COUNTY
HIGHWAY DEPT.

STATE PROJECT NO. _____

STATE AID PROJECT NO. _____

STATE AID PROJECT NO. _____

COUNTY PROJECT NO. 10-17-17

CSAH 17 (Lexington Ave)
TEMPORARY SIGNING
PERMANENT STRIPING
AND PAVEMENT MESSAGES

Sheet 16 of 20 Sheets

MATCHLINE 'F'

MATCHLINE 'G'

MATCHLINE 'G'

MATCHLINE 'H'

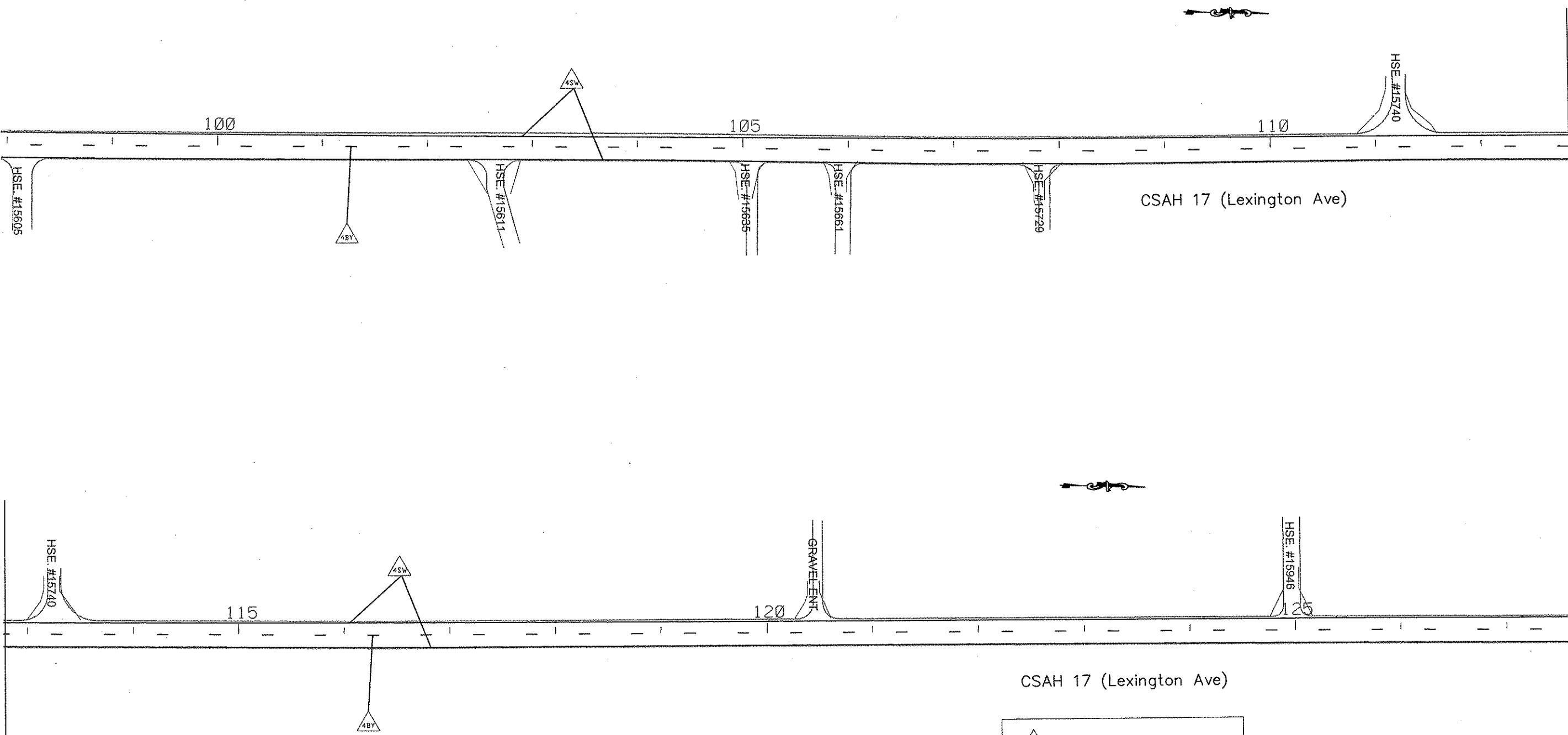

- NOTES:
1. LOCATIONS OF PAVEMENT MARKINGS ARE APPROXIMATE. EXACT LOCATIONS WILL BE DETERMINED IN THE FIELD BY THE ENGINEER.
 2. CONTRACTOR SHALL SUPPLY AND ERECT THE TEMPORARY TRAFFIC CONTROL SIGNS AS SHOWN ON THIS DRAWING FROM THE TIME WORK COMMENCES ON THIS ROADWAY UNTIL THIS ROADWAY IS PERMANENTLY STRIPED. THE TEMPORARY TRAFFIC CONTROL SIGNS SHALL BE PAID FOR AS PART OF TRAFFIC CONTROL LUMP SUM.
 3. ALL PERMANENT STRIPING AND PAVEMENT MESSAGES SHALL BE PLACED WITHIN 72 HOURS OF MAINLINE PAVING.

	4' SOLID LINE DOUBLE YELLOW EPOXY PAINT
	4' SOLID LINE YELLOW EPOXY PAINT
	4' BROKEN LINE YELLOW EPOXY PAINT
	4' SOLID LINE WHITE EPOXY PAINT
	4' BROKEN LINE WHITE EPOXY PAINT

NO	DATE	BY	CKD	APPR	REVISION

NAME: T:\Traffic\dwg\CSAH 17 (Lexington Av)\from CSAH 32 to CSAH 22.dwg

I HEREBY CERTIFY THAT THIS PLAN WAS PREPARED BY ME OR UNDER MY DIRECT SUPERVISION AND THAT I AM A DULY REGISTERED PROFESSIONAL ENGINEER UNDER THE LAWS OF THE STATE OF MINNESOTA.

PRINT NAME: *Charles Gadenberg*

SIGNATURE: *Charles Gadenberg*

DATE: *3/26/10* REG. NO. *40416*

DRAWN BY: MTH DATE: 2/23/10

DESIGN BY: _____ DATE: _____

CHECKED BY: _____ DATE: _____



ANOKA COUNTY
HIGHWAY DEPT.

STATE PROJECT NO. _____

STATE AID PROJECT NO. _____

STATE AID PROJECT NO. _____

COUNTY PROJECT NO. 10-17-17

CSAH 17 (Lexington Ave)
TEMPORARY SIGNING
PERMANENT STRIPING
AND PAVEMENT MESSAGES

Sheet 17 of 20 Sheets

	4" SOLID LINE DOUBLE YELLOW EPOXY PAINT
	4" SOLID LINE YELLOW EPOXY PAINT
	4" BROKEN LINE YELLOW EPOXY PAINT
	4" SOLID LINE WHITE EPOXY PAINT
	4" BROKEN LINE WHITE EPOXY PAINT

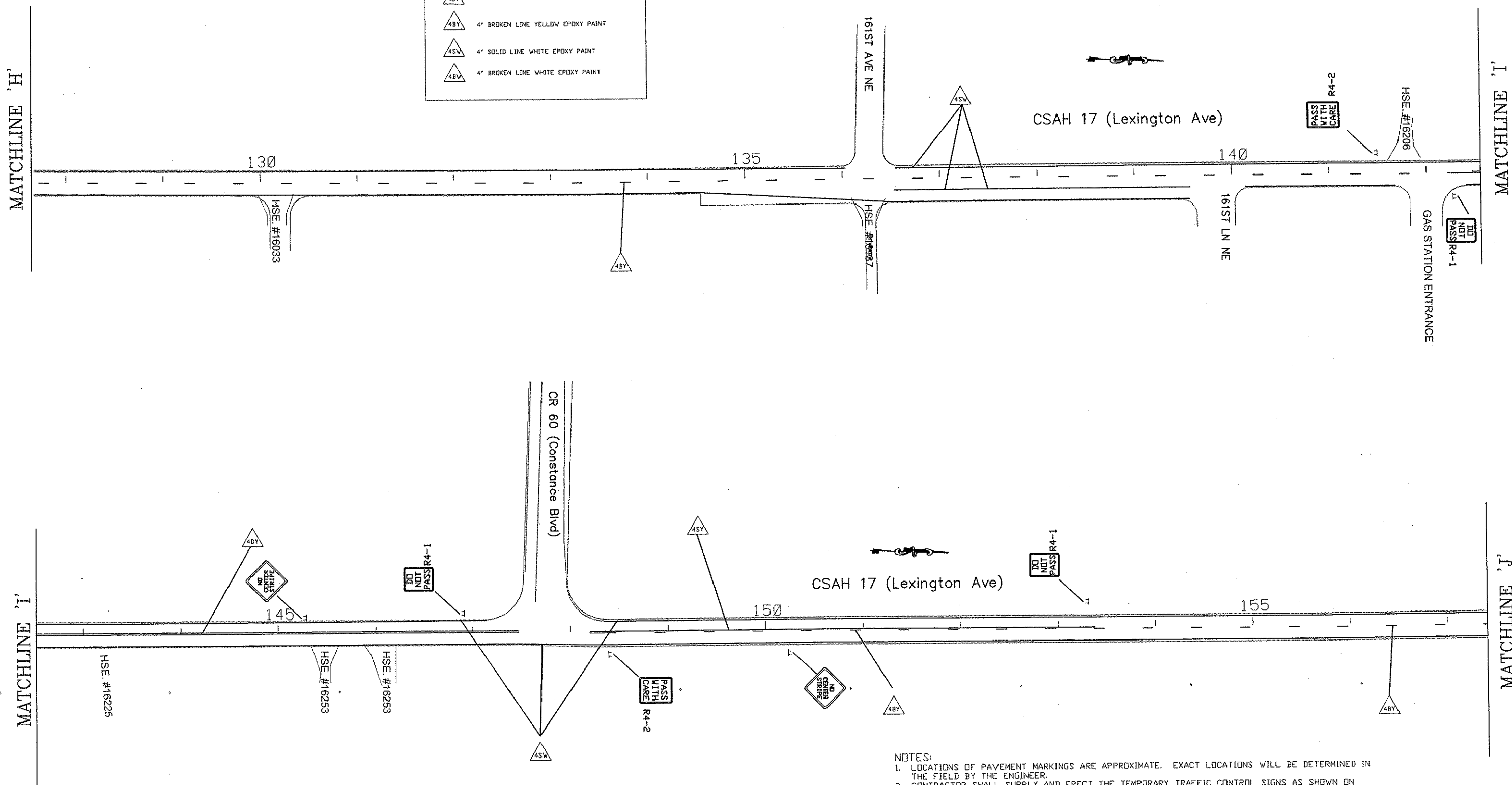

- NOTES:
1. LOCATIONS OF PAVEMENT MARKINGS ARE APPROXIMATE. EXACT LOCATIONS WILL BE DETERMINED IN THE FIELD BY THE ENGINEER.
 2. CONTRACTOR SHALL SUPPLY AND ERECT THE TEMPORARY TRAFFIC CONTROL SIGNS AS SHOWN ON THIS DRAWING FROM THE TIME WORK COMMENCES ON THIS ROADWAY UNTIL THIS ROADWAY IS PERMANENTLY STRIPED. THE TEMPORARY TRAFFIC CONTROL SIGNS SHALL BE PAID FOR AS PART OF TRAFFIC CONTROL LUMP SUM.
 3. ALL PERMANENT STRIPING AND PAVEMENT MESSAGES SHALL BE PLACED WITHIN 72 HOURS OF MAINLINE PAVING.

NO	DATE	BY	CKD	APPR	REVISION

NAME: T:\Traffic\dwg\CSAH 17 (Lexington Av) from CSAH 32 to CSAH 22.dwg

I HEREBY CERTIFY THAT THIS PLAN WAS PREPARED BY ME OR UNDER MY DIRECT SUPERVISION AND THAT I AM A DULY REGISTERED PROFESSIONAL ENGINEER UNDER THE LAWS OF THE STATE OF MINNESOTA.

PRINT NAME: *Charles C. Johnson*

SIGNATURE: *Charles C. Johnson*

DATE: *3/26/10* REG. NO. *40416*

DRAWN BY: MTH DATE: 2/23/10

DESIGN BY: _____ DATE: _____

CHECKED BY: _____ DATE: _____

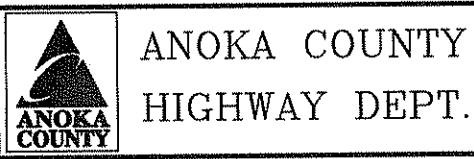

STATE PROJECT NO. _____

STATE AID PROJECT NO. _____

STATE AID PROJECT NO. _____

COUNTY PROJECT NO. 10-17-17

CSAH 17 (Lexington Ave)
 TEMPORARY SIGNING
 PERMANENT STRIPING
 AND PAVEMENT MESSAGES

Sheet 18 of 20 Sheets

MATCHLINE 'J'

MATCHLINE 'K'

MATCHLINE 'K'

MATCHLINE 'L'

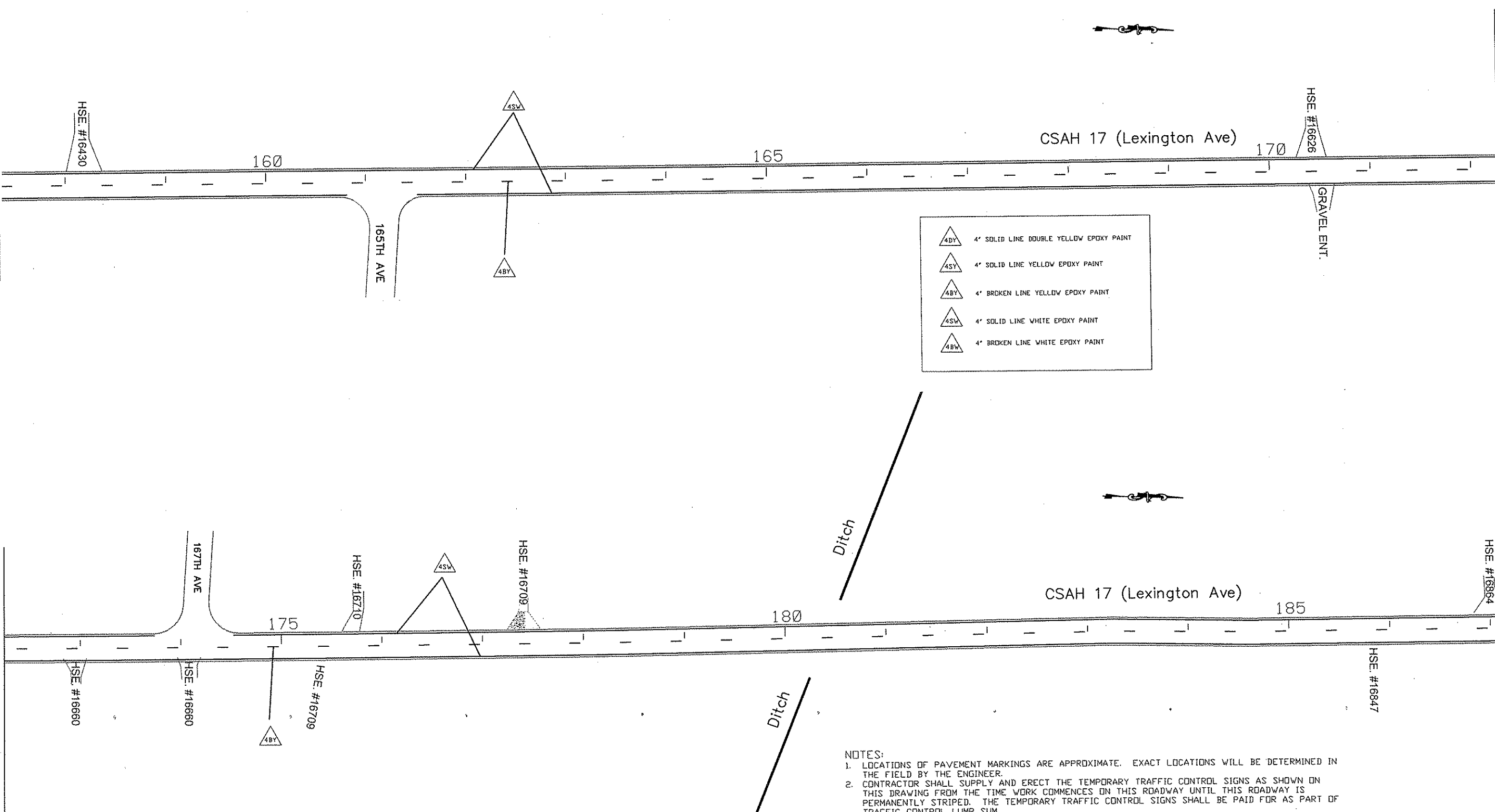

	4' SOLID LINE DOUBLE YELLOW EPOXY PAINT
	4' SOLID LINE YELLOW EPOXY PAINT
	4' BROKEN LINE YELLOW EPOXY PAINT
	4' SOLID LINE WHITE EPOXY PAINT
	4' BROKEN LINE WHITE EPOXY PAINT

- NOTES:
1. LOCATIONS OF PAVEMENT MARKINGS ARE APPROXIMATE. EXACT LOCATIONS WILL BE DETERMINED IN THE FIELD BY THE ENGINEER.
 2. CONTRACTOR SHALL SUPPLY AND ERECT THE TEMPORARY TRAFFIC CONTROL SIGNS AS SHOWN ON THIS DRAWING FROM THE TIME WORK COMMENCES ON THIS ROADWAY UNTIL THIS ROADWAY IS PERMANENTLY STRIPED. THE TEMPORARY TRAFFIC CONTROL SIGNS SHALL BE PAID FOR AS PART OF TRAFFIC CONTROL LUMP SUM.
 3. ALL PERMANENT STRIPING AND PAVEMENT MESSAGES SHALL BE PLACED WITHIN 72 HOURS OF MAINLINE PAVING.

NO	DATE	BY	CKD	APPR	REVISION

NAME: T:\Traffic\dwg\CSAH 17 (Lexington Av)\from CSAH 32 to CSAH 22.dwg

I HEREBY CERTIFY THAT THIS PLAN WAS PREPARED BY ME OR UNDER MY DIRECT SUPERVISION AND THAT I AM A DULY REGISTERED PROFESSIONAL ENGINEER UNDER THE LAWS OF THE STATE OF MINNESOTA.

PRINT NAME: *Charles Cook*

SIGNATURE: *Charles Cook*

DATE: *3/26/10* REG. NO. *4046*

DRAWN BY: MTH DATE: 2/23/10

DESIGN BY: _____ DATE: _____

CHECKED BY: _____ DATE: _____

ANOKA COUNTY
HIGHWAY DEPT.

STATE PROJECT NO. _____

STATE AID PROJECT NO. _____

STATE AID PROJECT NO. _____

COUNTY PROJECT NO. 10-17-17

CSAH 17 (Lexington Ave)
TEMPORARY SIGNING
PERMANENT STRIPING
AND PAVEMENT MESSAGES

Sheet 19 of 20 Sheets

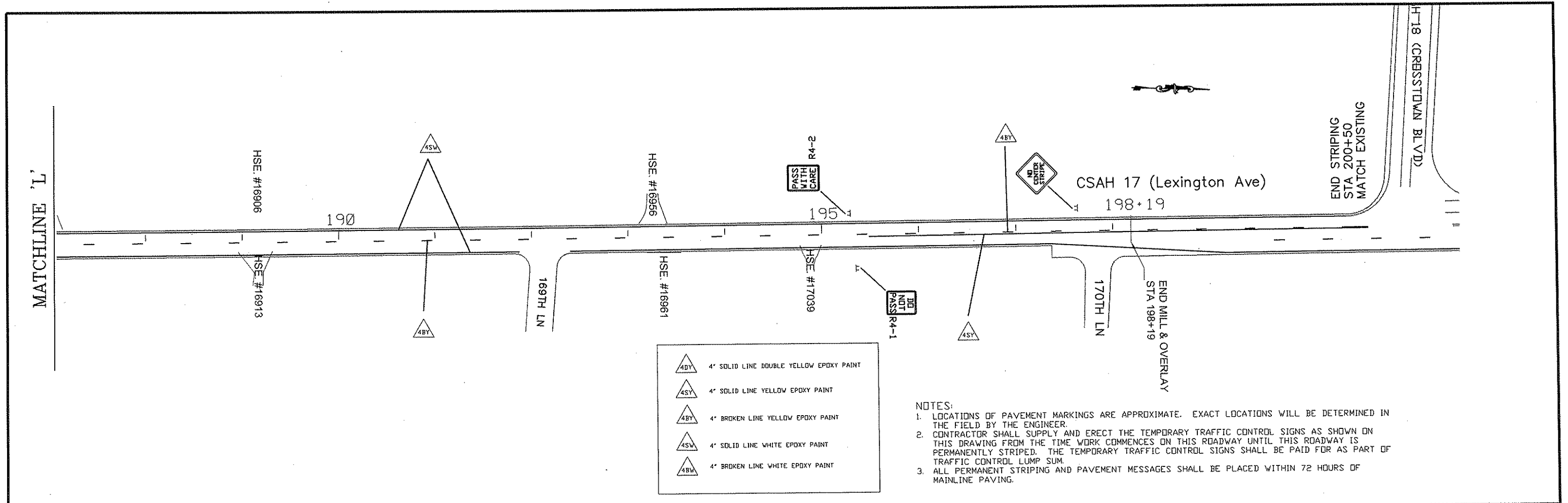

SIGN PANELS TYPE C

M. U. T. C. D. CODE	SIZE	PANEL AREA FT. ²	INSERT	QUANTITY		MOUNTING HEIGHT (TO PAVEMENT EDGE) FT.
					No. POST	
W8-12	48' x 48'	16.00		6	2	7.0'
R4-1	24' x 30'	5.00		8	1	7.0'
R4-2	24' x 30'	5.00		8	1	7.0'

GENERAL NOTES:

- ALL TRAFFIC CONTROL DEVICES SHALL CONFORM AND BE PLACED IN ACCORDANCE TO THE "MINNESOTA MANUAL ON UNIFORM TRAFFIC CONTROL DEVICES" (MN MUTCD), AND PART VI, "FIELD MANUAL FOR TEMPORARY TRAFFIC CONTROL ZONE LAYOUTS".