

PLAN SYMBOLS

COUNTY LINE	-----
TOWNSHIP OR RANGE LINE	-----
SECTION LINE	-----
QUARTER LINE	-----
SIXTEENTH LINE	-----
RIGHT OF WAY LINE	-----
SLOPE EASEMENT	-----
PRESENT RIGHT OF WAY	-----
PROPERTY LINE	-----
CORPORATE OR CITY LIMITS	-----
RETAINING WALL	-----
RAILROAD	-----
RAILROAD RIGHT OF WAY	-----
RIVER OR CREEK	-----
DRAINAGE DITCH	-----
CULVERT	-----
DROP INLET	-----
CAULD PAIL	-----
BARBED WIRE FENCE	-----
WOVEN WIRE FENCE	-----
CHAIN LINK FENCE	-----
WOOD FENCE	-----
STONE WALL OR FENCE	-----
HEDGE	-----
LOWLAND	-----
INVER	-----
ORCHARD	-----
BRUSH	-----
NURSER	-----
CATTLE GUARD	-----
OVERPASS (Highway Over)	-----
UNDERPASS (Highway Under)	-----
BRIDGE	-----
BUILDING (One Story Frame)	-----
P-FRAME	-----
S-STOVE	-----
B-BRICK	-----
RAILROAD CROSSING BELL	-----
RAILROAD CROSSING GATE	-----
WATER TOWER	-----
WATER TANK	-----
FIRE HYDRANT	-----
CAT. PILE MOUNTAIN	-----
ROCK PIT	-----
GRAVEL PIT	-----
SAND PIT	-----
BURIED PIT	-----
ROCK SHALLOWS	-----

UTILITY SYMBOLS

POWER POLE LINE	-----
TELEPHONE OR TELEGRAPH POLE LINE	-----
JOINT TELEPHONE & POWER OR POWER POLES ON TELEPHONE POLES	-----
ANCHOR	-----
STEEL TOWER	-----
STREET LIGHT	-----
PEDESTAL (Cable Terminal)	-----
GAS MAIN	-----
WATER MAIN	-----
TELEPHONE CABLE IN CONDUIT	-----
ELECTRIC CABLE IN CONDUIT	-----
TELEPHONE MANHOLE	-----
ELECTRIC MANHOLE	-----
BURIED TELEPHONE CABLE	-----
BURIED ELECTRIC CABLE	-----
AERIAL TELEPHONE CABLE	-----
SEWER (Sanitary or Storm)	-----
SEWER MANHOLE	-----

SCALES

PLAN	0 50 100
PROFILE HORIZONTAL	0 50 100
VERTICAL	0 5 10
X-SECTIONS HORIZONTAL	0 10 20
VERTICAL	0 10 20

NOT TO SCALE

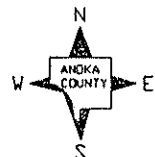

# MINNESOTA DEPARTMENT OF TRANSPORTATION

## ANOKA COUNTY

### CONSTRUCTION PLAN FOR BITUMINOUS OVERLAY

LOCATED ON C.S.A.H. 22 BETWEEN LIMITS OF EAST BETHEL AND EAST COUNTY LINE (Geographic Description)

STATE PROJ. NO. 02-622-25

COUNTY PROJ. NO.

MN PROJ. NO.

GROSS LENGTH 41,793.00 FEET 7.915 MILES  
 BRIDGES-LENGTH FEET MILES  
 EXCEPTIONS-LENGTH FEET MILES  
 NET LENGTH 41,793.00 FEET 7.915 MILES

GROSS LENGTH FEET MILES  
 BRIDGES-LENGTH FEET MILES  
 EXCEPTIONS-LENGTH FEET MILES  
 NET LENGTH FEET MILES

### LINWOOD TOWNSHIP

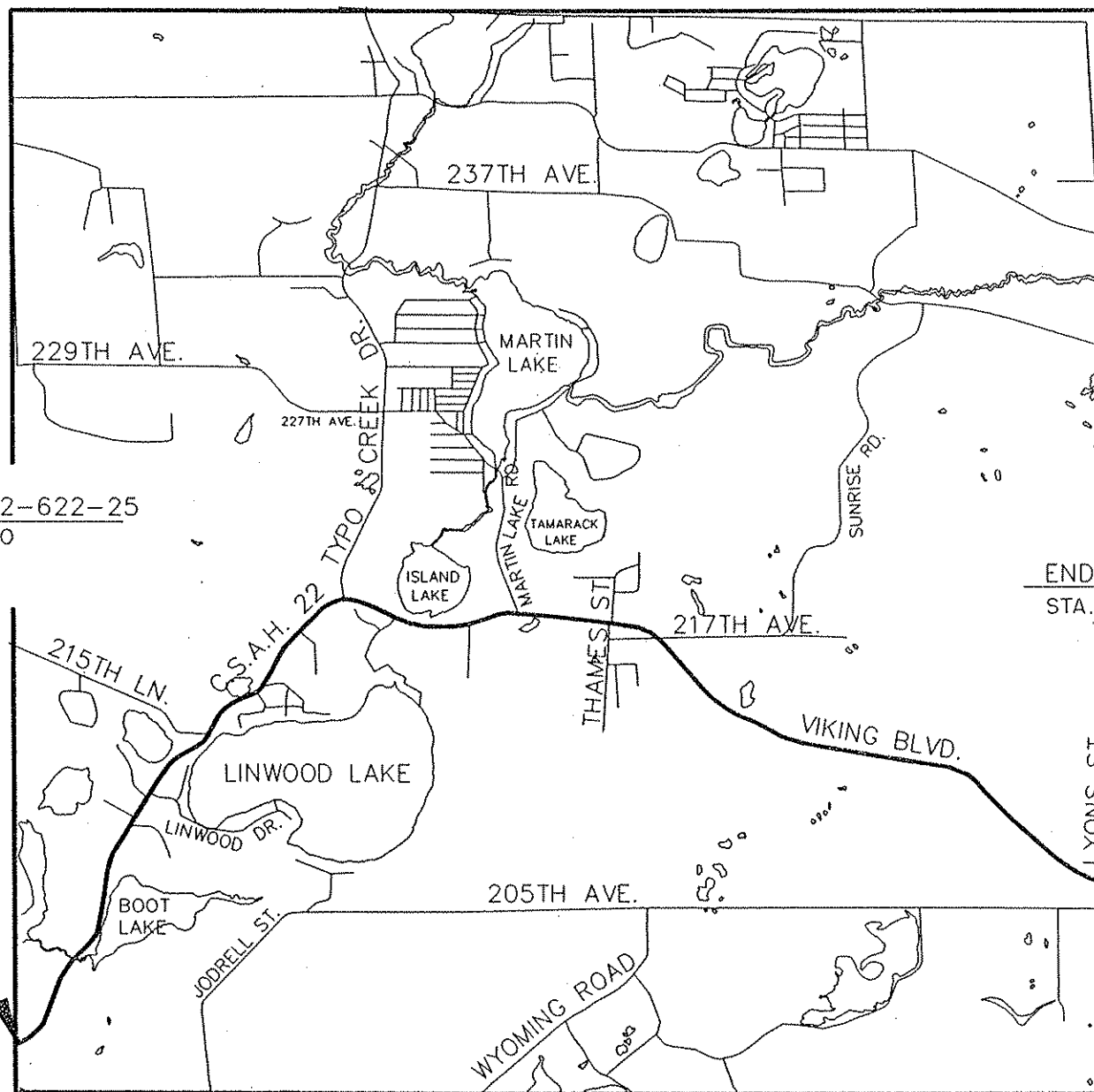

MINN. PROJ. NO. \_\_\_\_\_  
 MINN. PROJ. NO. STP PAVE (010) \_\_\_\_\_

GOVERNING SPECIFICATIONS

THE 1988 EDITION OF THE MINNESOTA DEPARTMENT OF TRANSPORTATION "STANDARD SPECIFICATIONS FOR CONSTRUCTION" AS AMENDED BY THE JANUARY 2, 1991 SUPPLEMENTAL SPECIFICATIONS SHALL GOVERN.

INDEX

SHEET NO.	DESCRIPTION
1	TITLE SHEET
2	ESTIMATED QUANTITIES
3-5	TABULATED QUANTITIES
6	TYPICAL QUANTITIES
7	STANDARD DETAILS
8	TRAFFIC CONTROL

THIS PLAN CONTAINS 8 SHEETS

DESIGN DESIGNATION

£1820 NA  
 R VALUE NA  
 ADT (1993)= 4556  
 Proj. ADT (2013)= 7745  
 Proj. HCADT (2013)= 581  
 Soil Factor 50%  
 9 TON DESIGN  
 Shoulder Width 8'-10'  
 Functional Classification  
 No. of Traffic Lanes 2 No. of Parking Lanes 0  
 Design Speed MPH 55  
 Based on Stopping Sight Distance  
 Height of eye 3.5 Height of object 0.5  
 Design Speed not achieved at:  
 STA. 297+84 TO STA. 303+84 MPH 45  
 STA. 342+24 TO STA. 346+24 MPH 40  
 STA. 360+24 TO STA. 366+24 MPH 45  
 STA. 371+24 TO STA. 381+74 MPH 45  
 STA. 386+69 TO STA. 390+69 MPH 45

I HEREBY CERTIFY THAT THIS PLAN WAS PREPARED BY ME OR UNDER MY DIRECT SUPERVISION AND THAT I AM A DULY REGISTERED PROFESSIONAL ENGINEER UNDER THE LAWS OF THE STATE OF MINNESOTA.

DATE 8/27/93 REG. NO. 20235 ENGR. *Donald M. Timbo* ANOKA COUNTY DESIGN ENGINEER  
 DESIGN SQUAD J. TRICK

Recommended for Approval *Michael R. Kelly* 8/27, 1993  
 Recommended for Approval *Steve Demko* 8/27, 1993  
 Recommended for Approval *Don Schmitt* 8/27, 1993  
 Approved 8/30, 1993 *Paul J. Linn* ANOKA COUNTY ENGINEER  
 Approved 9-7-1993 *Vern J. Williams* TOWNSHIP OF LINWOOD  
 Recommended for Approval *Mary E. Burington* 11/10, 1993  
 Recommended for Approval *Mark K. Kutsch* 1993  
 Approved 4/5, 1994 *John Stallman* STATE AID ENGINEER

DEPARTMENT OF TRANSPORTATION  
 FEDERAL HIGHWAY ADMINISTRATION  
 APPROVED \_\_\_\_\_  
 DIVISION ADMINISTRATOR DATE

STATEMENT OF ESTIMATED QUANTITIES

CHART ID	ITEM NO.	ITEM	UNIT	TOTAL QUANTITIES		S.P. 02-622-25		NON-PARTICIPATING	
				ESTIMATE	FINAL	ESTIMATE	FINAL	ESTIMATE	FINAL
	0015.601	COMPUTER EQUIPMENT	LUMP SUM	0.48		0.48			
A/F	2104.501	REMOVE PIPE CULVERTS	LIN FT	1206		1206			
D	2104.501	REMOVE RETAINING WALL	LIN FT	233		233			
D	2104.505	REMOVE SLOPE PAVING	SQ YD	6		6			
D	2104.505	REMOVE BITUMINOUS PAVEMENT	SQ YD	53		53			
D	2104.509	REMOVE MISCELLANEOUS STRUCTURES	EACH	1		1			
D	2104.509	REMOVE POST	EACH	3		3			
A	2104.509	REMOVE PIPE APRON	EACH	5		5			
D	2104.521	SALVAGE WOOD RAIL FENCE	LIN FT	112		112			
F	2104.521	SALVAGE PIPE CULVERT	LIN FT	18		18			
F	2104.523	SALVAGE CONCRETE APRON	EACH	1		1			
A/C	2105.523	COMMON BORROW (LV)	CU YD	6281		6281			
	2211.501	AGGREGATE BASE CLASS 5	TON	18		18			
	2232.501	MILL BITUMINOUS SURFACE	SQ YD	1076		1076			
	2340.508	TYPE 41 WEARING COURSE MIXTURE	TON	9314		9314			
	2340.512	TYPE 31 LEVELING COURSE MIXTURE	TON	281		281			
	2340.514	TYPE 31 BASE COURSE MIXTURE	TON	85		85			
	2340.516	TYPE 41 SHOULDER MIXTURE	TON	6385		6385			
	2357.502	BITUMINOUS MATERIAL FOR TACK COAT	GAL	9901		9901			
B	0412.602	MAILBOX SUPPORT	EACH	73		72		1	
	2451.509	AGGREGATE BEDDING (CV)	CU YD	38		38			
	2501.501	CULVERT EXCAVATION CLASS U	CU YD	274		274			
A	2501.511	15" CS PIPE CULVERT	LIN FT	1396		1396			
A	2501.511	18" CS PIPE CULVERT	LIN FT	711		711			
A	2501.515	24" RC PIPE APRON	EACH	2		2			
A	2501.561	24" RC PIPE CULVERT DES 3006 CL II	LIN FT	70		70			
F	2501.571	INSTALL PIPE CULVERT	LIN FT	18		18			
F	2501.573	INSTALL CONCRETE APRON	EACH	1		1			
A	0501.602	15" CS SAFETY APRON	EACH	144		144			
A	0501.602	18" CS SAFETY APRON	EACH	35		35			
D	0557.603	INSTALL WOOD RAIL FENCE	LIN FT	112		112			
	0563.601	TRAFFIC CONTROL	LUMP SUM	0.48		0.48			
E	2575.502	SEED MIXTURE 700	LB	118		118			
E	2575.505	SODDING TYPE EROSION	SQ YD	3133		3133			
E	2575.511	MULCH MATERIAL TYPE 1	TON	7		7			
E	2575.521	POLYPROPYLENE PLASTIC NETTING	SQ YD	6763		6763			
E	2575.532	COMMERCIAL FERTILIZER ANALYSIS 10-10-10	LB	2036		2036			
E	0575.605	SEEDING	SQ YD	16,576		16,576			
E	0575.605	DISK ANCHORING	SQ YD	9792		9792			
	2580.605	TEMPORARY LANE MARKING	ROAD STA	388		388			

NOTES:

- ① ALL TRAFFIC CONTROL DEVICES AND SIGNING SHALL CONFORM TO THE MMUTCD, INCLUDING APPENDIX B DATED NOVEMBER 1992.
- ② PER STANDARD PLATE 3128. NO GRATE REQUIRED.
- ③ INCLUDES ALL PIPE COUPLINGS AS REQUIRED.
- ④ INCLUDES MATERIAL NEEDED FOR CENTERLINE CULVERT REPLACEMENT, CULVERT EXTENSIONS AND INSLOPE CORRECTIONS.
- ⑤ MILL TOUCHDOWN AREAS (20' LONG, FULL WIDTH) AT BEGIN AND END POINTS.
- ⑥ INCLUDES SALVAGING & INSTALLING OF OLD BOX AND F & I NEW SUPPORT. (ONE TYPE II REQ. (NON-PARTICIPATING.))
- ⑦ FOR CENTERLINE CULVERT INSTALLATION ONLY.
- ⑧ 12 TON USED FOR 3 1/2" LIFT FOR CENTERLINE CULVERT REPLACEMENT. 73 TON USED AS LEVELING COURSE AT LOCATIONS AS DIRECTED BY THE ENGINEER.
- ⑨ FOR VERTICAL CURVE CORRECTION AS DIRECTED BY THE ENGINEER.
- ⑩ LANDSCAPE BOX
- ⑪ INCLUDES 120 TON FOR APPROACHES AND ENTRANCES.
- ⑫ LANDSCAPE ROCK

BASIS OF QUANTITIES:

BITUMINOUS MIXTURES: 110/LB/SY/IN  
 BITUMINOUS MAT'L FOR TACK: 0.05 GAL/SY  
 SEED MIXTURE NO. 700: 35 LBS/ACRE  
 MULCH MAT'L TYPE 1: 2 TONS/ACRE  
 COMMERCIAL FERTILIZER, ANALYSIS 10-10-10: 500 LBS/ACRE  
 SEEDING: HORIZONTAL MEASUREMENT +10%  
 BITUMINOUS MIXTURE DESIGNATIONS:  
 31 BBB 50000Y  
 31 LVA 50000Y  
 41 WEA 50070Y  
 41 SHA 50070Y

THESE STANDARD PLATES, AS APPROVED BY THE FHWA SHALL APPLY

STANDARD PLATES

0005 A	SPECIFICATION REFERENCE TO STANDARD PLATES
3000 L	REINFORCED CONCRETE PIPE
3006 F	GASKET JOINT FOR R.C. PIPE
3040 F	CORRUGATED METAL PIPE CULVERT
3100 G	CONCRETE APRON FOR REINFORCED CONCRETE PIPE
3128 F	SAFETY APRON
3145 E	CONCRETE PIPE TIES
3221 C	CORRUGATED STEEL PIPE COUPLING BAND
8000 I	STANDARD BARRICADES
9102 D	TURF ESTABLISHMENT AREAS

CHART ID	SHEET NO.	DESCRIPTION
A	3	ENTRANCE APPROACH IMPROVEMENTS
B	4	MAILBOX SUPPORTS
C	4	INSLOPE EMBANKMENT
D	4	MISCELLANEOUS REMOVALS
E	5	TURF ESTABLISHMENT
F	3	CENTERLINE CULVERTS

ESTIMATED QUANTITIES



MAILBOX SUPPORT CHART (B)			
STATION	LOCATION	ADDRESS	RELOCATE
184+25	10' RT	19835	1
187+67	13' RT	19925	1
189+30	15' RT	19932	1
192+03	11' RT	20015	1
194+90	11' RT	20022	1
197+03	11' RT	20053	1
197+06	11' RT	20062	1
199+07	12' RT	20101	1
199+10	12' RT	20102	1
211+10	14' RT	20257	1
214+02	11' RT	20310	1
224+02	11' LT	20410	1
229+29	11' LT	20516	1
245+24	11' RT	20730	1
246+88	12' RT	20740	1
248+15	10' RT	20761	1
249+77	10' RT	20760	1
250+75	11' RT	20800	1
251+23	11' RT	20787	1
253+70	15' RT	20830	1
253+92	12' RT	20845	1
254+76	13' RT	20890	1
274+41	15' LT	21120	1
278+80	14' RT	21111	1
281+44	14' RT	21185	1
281+60	12' LT	21230	1
285+15	11' RT	21205	1
291+22	12' RT	21295	1
292+39	11' RT	21299	1
294+85	13' RT	21301	1
295+54	15' RT	21305	1
297+45	17' RT	21311	1
299+22	12' RT	21315	1
303+50	11' LT	21415	1
307+47	12' RT	21441	1
325+95	12' RT	21619	1
334+63	12' LT	21770	1
359+92	11' LT	6565	1
374+58	12' RT	6752	1
374+60	13' RT	6810	1
389+68 TD			
389+82	14' RT	①	2
393+05	12' LT	7023	1
394+61	12' LT	7051	1
403+64	12' RT	7150/7166	2
409+95	10' LT	7227	1
416+75	11' RT	7361	1
419+34	12' RT	7415	1
421+11	11' RT	7445	1
425+44	13' RT	7503	1
437+10	12' LT	?	1
438+48	12' LT	7701	1
444+38	13' RT	7801	1
461+63	12' LT	7957	1
462+29	13' LT	8045	1
465+37	13' RT	8176	1
468+57	11' LT	8065	1
469+21	11' LT	8195	1
475+32	14' LT	8197	1
479+01	12' RT	NO #	1
480+15	11' RT	8210/8220	2
482+30	11' RT	8215/8230	2
485+25	12' LT	8245	1
487+07	12' LT	8265/8303	2
572+81	12' LT	9431	1
575+65	12' LT	9455	1
583+28	11' RT	9554	1
584+21	12' LT	9555	1
597+91	14' RT	9724	1
TOTALS			73

NOTE:

- ① THIS WILL REQUIRE ONE TYPE I AND ONE TYPE II. THE TYPE I WILL BE ON CTY. RD. 22 #7024. THE TYPE II WILL BE PLACED ON HUMBER ST. WITH THE FOLLOWING NUMBERS: 21691, 21662, 21575, 21533, 21519, 21615, 21651.

INSLOPE EMBANKMENT CHART (C)					
STA. TO STA.	LOC	EXIST. SLOPE	FIN. SLOPE	EMBANKMENT (CU. YD.)	
184+05 TO 185+95	RT	3.5:1	4:1	23.0	
195+84 TO 196+84	LT	3.3:1	4:1	10.0	
195+88 TO 197+38	RT	3.6:1	4:1	13.0	
208+81 TO 215+41	LT	2.7:1	4:1	1923.0	
245+87 TO 248+67	LT	3.0:1	4:1	188.0	
278+51 TO 278+81	RT	3.5:1	4:1	41.0	
287+00 TO 288+90	RT	3.4:1	4:1	28.0	
334+00 TO 341+00	LT	3.6:1	4:1	302.0	
358+00 TO 359+59	LT	3.8:1	4:1	4.0	
366+50 TO 369+50	LT	3.6:1	4:1	257.0	
379+50 TO 384+50	LT	3.1:1	4:1	116.0	
378+50 TO 385+50	RT	3.3:1	4:1	627.0	
406+50 TO 408+00	LT	3.4:1	4:1	22.0	
TOTALS				3554	

① EARTHWORK SUMMARY: COMMON BORROW (LV) = EMBANKMENT x 1.5 = 3554 x 1.5 = 5331 C.Y.

MISCELLANEOUS REMOVAL CHART (D)									
STATION	LOCATION	ITEM							REMARKS
		FENCE (LF)	SPLICE BOX (EA)	ROCK AT CULV. (SY)	MISC WALLS (LF)	FLOWER BOX (EA)	POST (EA)	POWER POLE (EA)	
198+79	14' RT							1	METAL CONC BLOCK
199+02	18' RT								
251+48	15' RT			5.8					FLAGSTONE
278+39	18' RT								FLAGSTONE
278+63	16' RT								
284+80	8' RT								4x6 TIMBER RET
285+10	8' RT								4x6 TIMBER RET
288+51	17' RT								REMOVED BY DTH
289+44	15' RT								REMOVED BY DTH
289+44	15' RT								REMOVED BY DTH
290+48	20' RT								REMOVED BY DTH
291+18 TD									
291+50	15' RT	30.5							SPLIT RAIL
291+73 TD									
292+44	15' RT	81.0							SPLIT RAIL
292+08	16' RT							1	REMOVED BY DTH
292+16	17' RT								REMOVED BY DTH
343+98 TD									
344+03	18' LT								LANDSCAPE TIMB WOOD
343+86	19' LT							1	WOOD
345+77	17' LT								8x8 RR TIE RET
596+32	17' RT				43				
TOTALS		111.5	2	5.8	233	1	3	4	

TABULATED QUANTITIES

TURF ESTABLISHMENT (E)								
STATION	LOC	SEEDING	SEED MIX 700	SODDING TYPE EROSION CONTROL	MULCH MATERIAL TYPE 1	DISK ANCHORING	COMMERCIAL FERTILIZER ANALYSIS 10-10-10	POLYPROPYLENE PLASTIC NETTING
		SQ YD	LB.	SQ YD	TON	SQ YD	LB.	SQ. YD.
184+05	RT	111	0.8		.05		11.5	111
184+05 TO 185+95	RT	271	1.9		.11	271	28.0	
184+76	LT	82	0.6		.03		8.5	82
189+32	LT			53			5.5	
194+90	LT			77			8.0	
195+84 TO 196+84	LT	97	0.7		.04	97	10.0	
195+88 TO 197+38	RT	184	1.3		.08	184	19.0	
196+84	LT			68			7.0	
197+38	RT	106	0.8		.04		11.0	106
198+80	RT	73	0.5		.03		7.5	73
199+09	LT			118			12.2	
199+57	RT	102	0.7		.04		10.5	102
208+81 TO 215+41	LT	1970	14.2		.81	1970	203.5	
211+36	RT			72			7.4	
213+81	LT			116			12.0	
215+50	LT	87	0.6		.04		9.0	87
223+56	LT			67			6.9	
229+55	LT			87			9.0	
245+21	LT	184	1.3		.08		19.0	184
245+87 TO 248+67	LT	561	4.1		.23	561	58.0	
246+57	LT	111	0.8		.05		11.5	111
248+00	RT			128			13.2	
249+95	LT			65			6.7	
250+75	LT			56			5.8	
251+48	RT			84			8.7	
253+80	LT			82			8.5	
254+10	RT			62			6.4	
254+76	LT	63	0.5		.03		6.5	63
256+25	LT	63	0.5		.03		6.5	63
258+20	RT	126	0.9		.05		13.0	126
266+94	LT	87	0.6		.04		9.0	87
274+60	LT	111	0.8		.05		11.5	111
276+05	RT	58	0.4		.02		6.0	58
278+51	RT	198	1.4		.08		20.5	184
278+51 TO 278+81	RT	286	2.1		.12	286	29.5	
280+75	LT	121	0.9		.05		12.5	121
281+18	RT	653	0.5		.03		7.5	73
281+89	LT	140	1.0		.06		14.5	140
284+95	RT			64			6.6	
287+00 TO 288+90	RT	257	1.9		.11	257	26.5	
287+39	LT	48	0.3		.02		5.0	48
292+53	RT	48	0.3		.02		5.0	48
294+68	RT	44	0.3		.02		4.5	44
295+71	RT			53			5.5	
296+55	RT			40			4.1	
297+60	RT			62			6.4	
299+38	RT	82	0.6		.03		8.5	82
299+90	LT	116	0.8		.05		12.0	116
303+75	LT	179	1.3		.07		18.5	179
306+45	RT	48	0.3		.02		5.0	48
307+60	RT			93			9.6	
313+38	RT	121	0.9		.05		12.5	121
314+46	RT	87	0.6		.04		9.0	87
315+54	RT	97	0.7		.04		9.9	90
334+00 TO 341+00	LT	1970	14.2		.81	1970	203.5	
334+93	LT	58	0.4		.02		6.0	58
346+00	LT			92			9.5	
346+25	RT	186	0.8		.04		11.0	186
351+43	LT	257	1.9		.11		26.5	257
353+60	LT	140	1.0		.06		14.5	140
353+80	LT	121	0.9		.05		12.5	121
356+40	RT	68	0.5		.03		7.0	68
358+00 TO 359+50	LT	194	1.4		.08	194	20.0	
359+59	LT			181			10.4	
365+59	RT	92	0.7		.04		9.5	92
366+50 TO 369+50	LT	1137	8.2		.47	1137	117.5	
367+34	RT	111	0.8		.05		11.5	111
373+83	LT	116	0.8		.05		12.0	116
374+41	RT	155	1.1		.06		16.0	155
378+50 TO 385+50	RT	2052	14.8		.85	2052	212.0	
379+50 TO 384+50	LT	610	4.4		.25	610	63.0	
387+98	RT	92	0.7		.04		9.5	92
393+29	LT			171			17.7	
394+79	LT	218	1.6		.09		22.5	218
403+88	RT	63	0.5		.03		6.5	63
406+50 TO 408+00	LT	203	1.5		.08	203	21.0	
408+00	LT			63			6.5	
410+16	LT			67			6.9	
410+70	RT	77	0.6		.03		8.0	77
417+88	RT	102	0.7		.04		10.5	102
419+27	LT	82	0.6		.03		8.5	82

TURF ESTABLISHMENT (E) (CONT.)								
STATION	LOC	SEEDING	SEED MIX 700	SODDING TYPE EROSION CONTROL	MULCH MATERIAL TYPE 1	DISK ANCHORING	COMMERCIAL FERTILIZER ANALYSIS 10-10-10	POLYPROPYLENE PLASTIC NETTING
		SQ YD	LB.	SQ. YD.	TON	SQ YD	LB.	SQ. YD.
421+11	LT	92	0.7		.04		9.5	92
422+91	LT	87	0.6		.04		9.0	87
430+87	RT	102	0.7		.04		10.5	102
431+44	LT	116	0.8		.05		12.0	116
436+90	LT			120			12.4	
438+72	LT			113			11.7	
444+28	LT	126	0.9		.05		13.0	126
445+19	RT	63	0.5		.03		6.5	63
446+45	LT	126	0.9		.05		13.0	126
453+25	RT	73	0.5		.03		7.5	73
453+25	LT	92	0.7		.04		9.5	92
459+25	RT	82	0.6		.03		8.5	82
461+96	LT			72			7.4	
465+19	RT			69			7.1	
467+85	LT	92	0.7		.04		9.5	92
468+85	LT	184	1.3		.08		19.0	184
471+10	RT	97	0.7		.04		10.0	97
471+85	LT	97	0.7		.04		10.0	97
475+58	LT	87	0.6		.04		9.0	87
479+56	RT	116	0.8		.05		12.0	116
481+83	LT	73	0.5		.03		7.5	73
482+08	RT	68	0.5		.03		7.0	68
485+57	LT			84			8.7	
486+61	LT			114			11.8	
487+44	LT			96			9.9	
572+67	RT	145	1.0		.06		15.0	145
572+67	LT			110			11.4	
575+48	LT			77			8.0	
578+23	LT			75			7.7	
584+21	LT			100			10.3	
584+32	RT	48	0.3		.02		5.0	48
586+85	LT	68	0.5		.03		7.0	68
594+00	LT	58	0.4		.02		6.0	58
596+32	RT	68	0.5		.03		7.0	68
597+64	RT			162			16.7	
TOTALS		16,576	118.5	3133	6.88	9792	2036.0	6763

TABULATED QUANTITIES

### TYPICAL SECTION

Ⓐ STATION 184+04 TO STATION 404+76

Ⓑ STATION 404+76 TO STATION 601+97

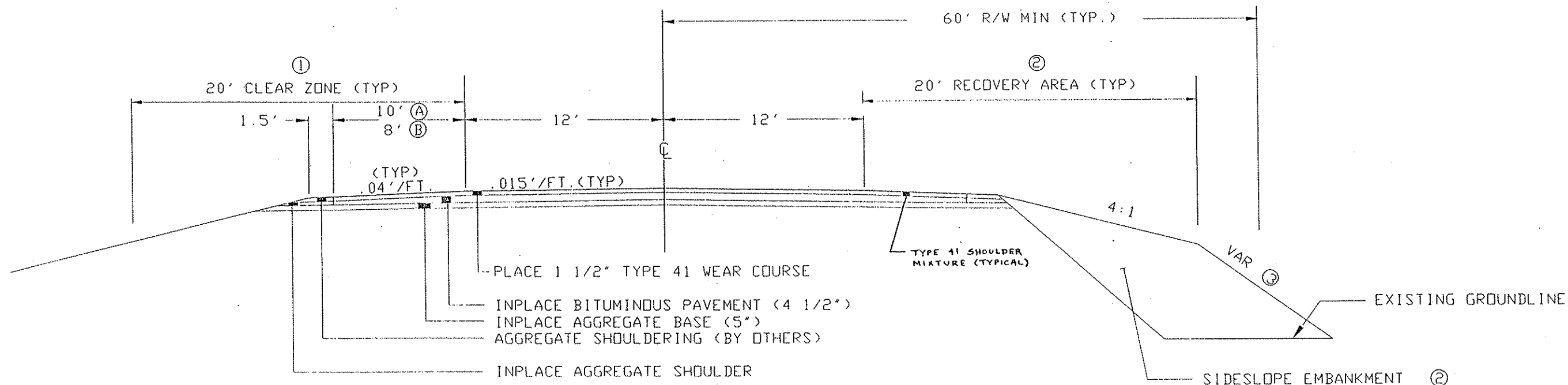

NOTES:

- Ⓐ PROVIDE OBSTACLE-FREE AREA WITHIN THIS ZONE. SEE CHART D FOR MISCELLANEOUS REMOVALS.
- Ⓑ PROVIDE A 4:1 SHOULDER INSLOPE WITHIN RECOVERY AREA. SEE CHART C FOR EMBANKMENT REQUIREMENTS.
- Ⓒ 3:1 MAXIMUM

TYPICAL SECTION

REVISIONS			
DATE	BY	DATE	BY



### CENTERLINE CULVERT INSTALLATION

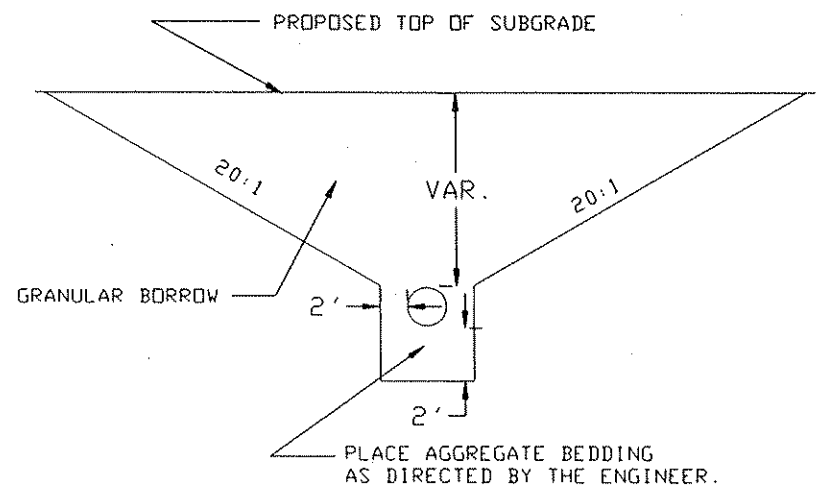

- NOTES:
- \* FILL AND COMPACT GRANULAR TO 4" ABOVE FLOWLINE BEFORE PLACING CULVERT.
  - \* AT CENTERLINE CULVERT LOCATIONS CULVERT EXCAVATION TO EXTEND 3' BEYOND END OF APRON.

### TYPICAL ENTRANCES

#### PAVED AND UNPAVED STREETS AND ENTRANCES

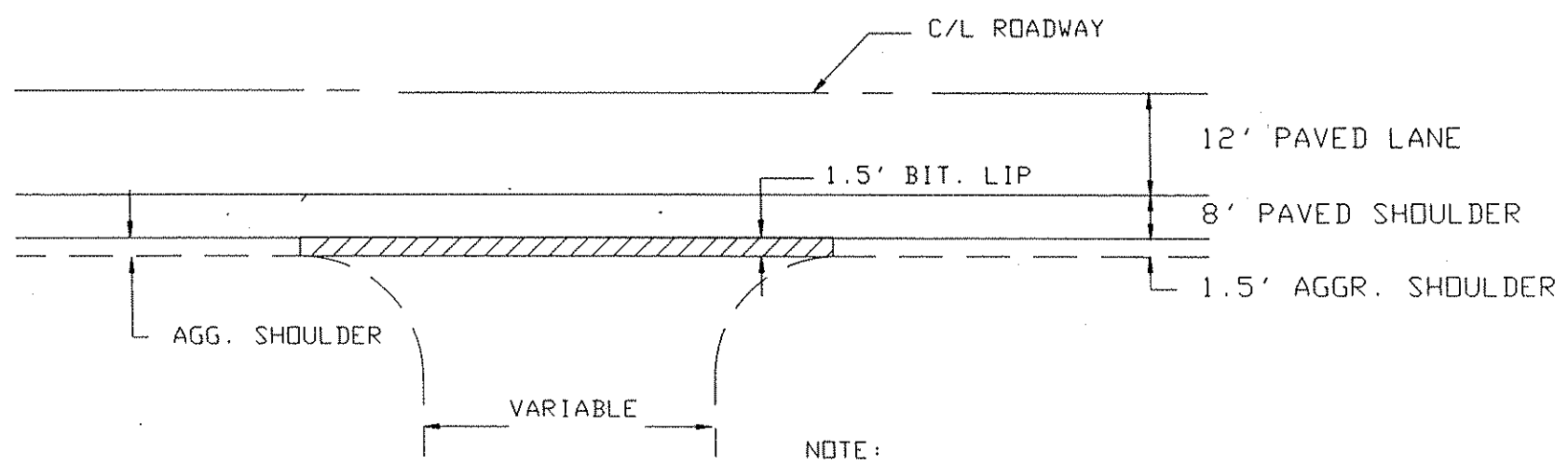

NOTE:  
ON PAVED ENTRANCES  
TACK PAVEMENT &  
FEATHER BIT. TO  
BLEND WITH EXISTING  
DRIVEWAY.

NOTE: NOT TO SCALE,

### ENTRANCE SLOPES

#### FILL SECTION

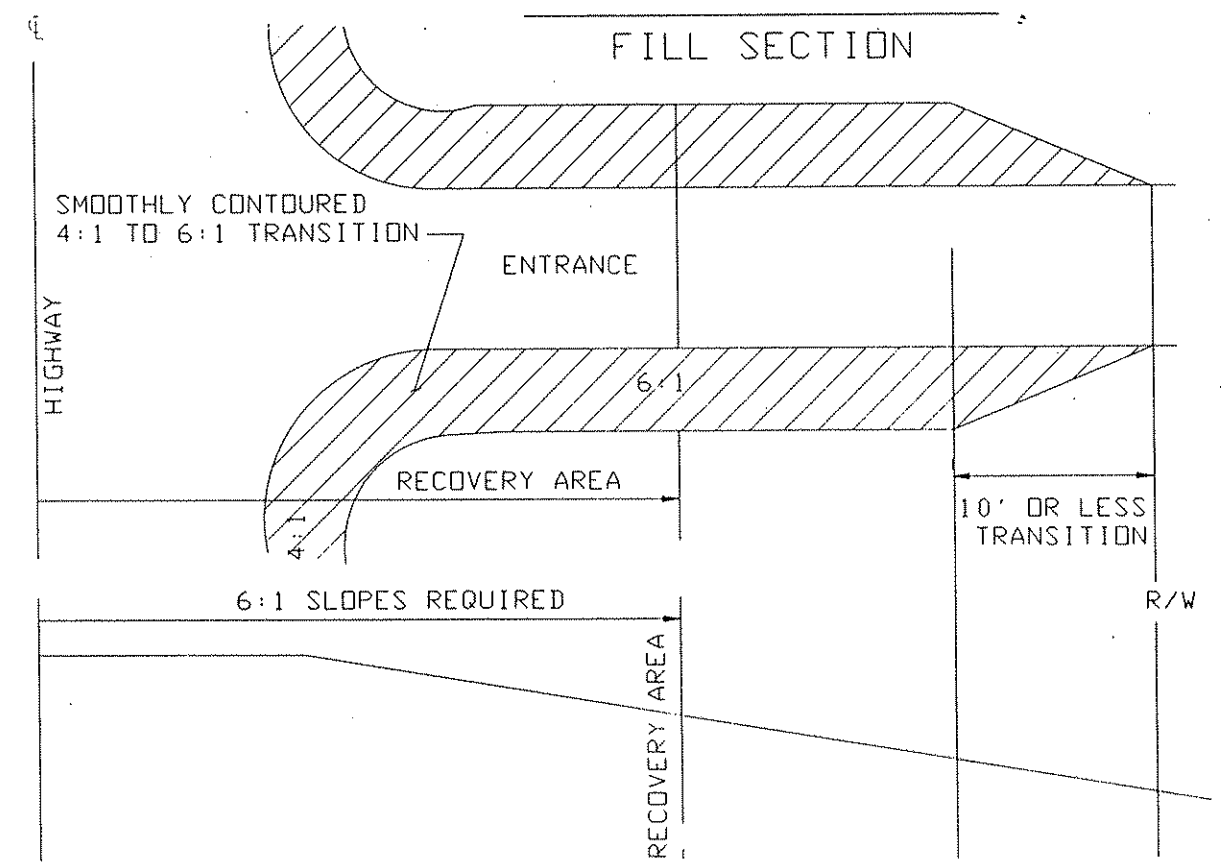

#### DITCH SECTION

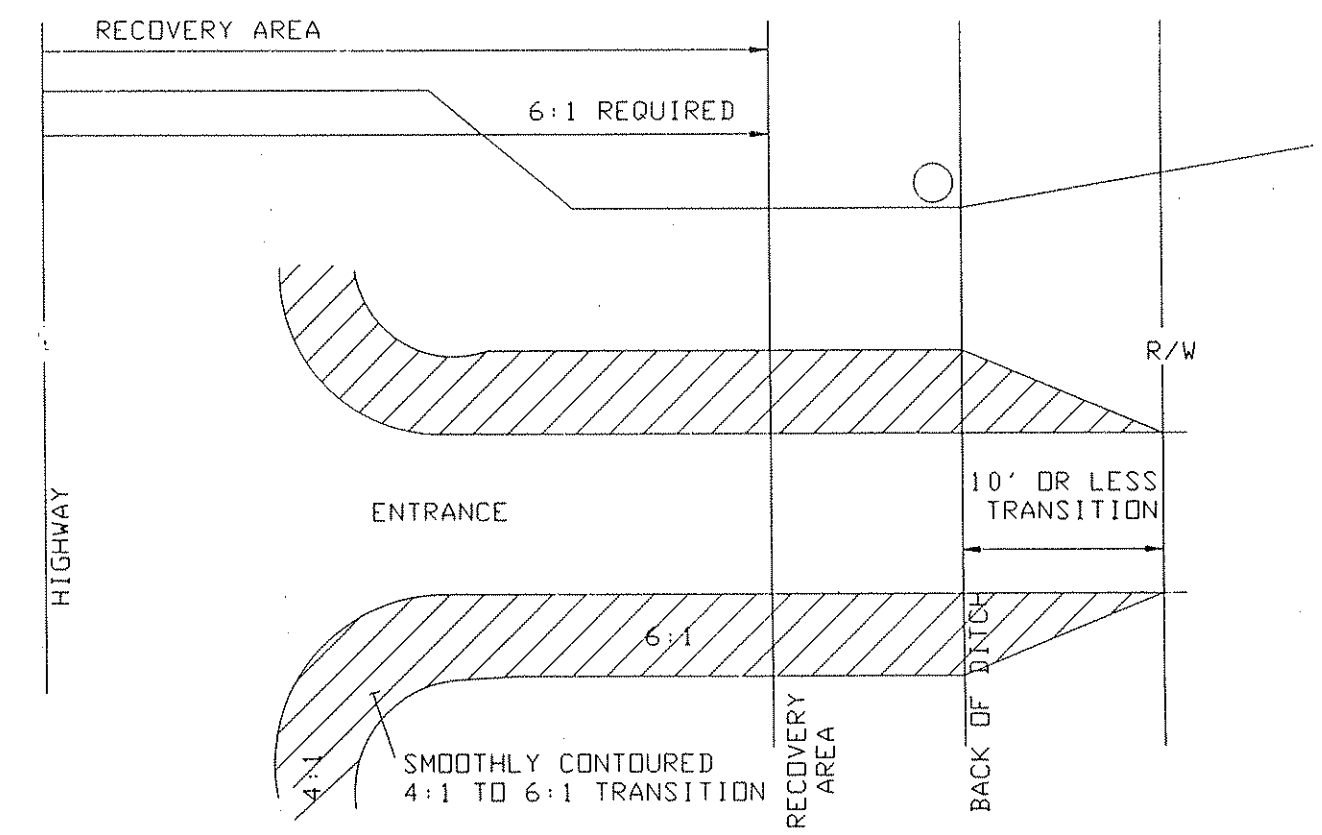

### STANDARD DETAILS

**EDGE DROP OFF**

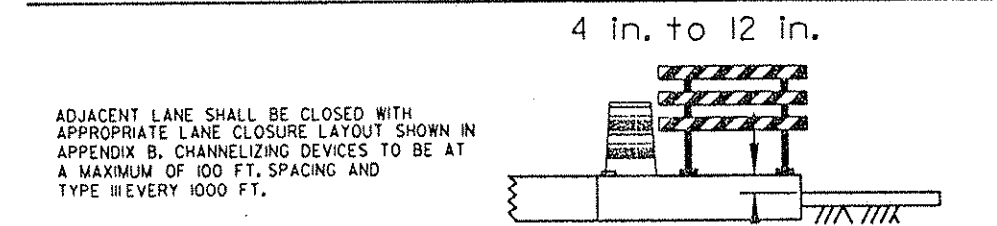
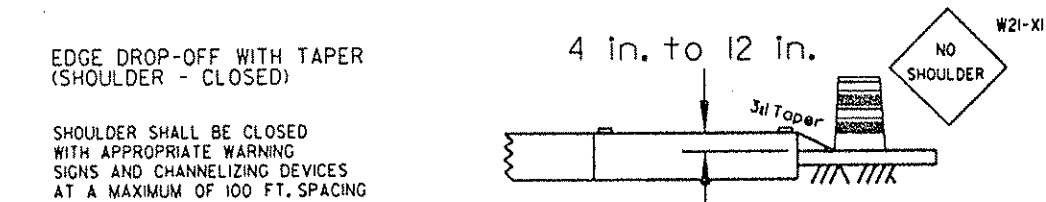
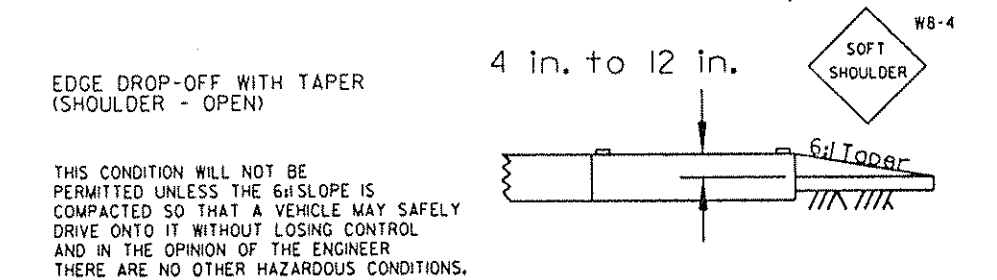
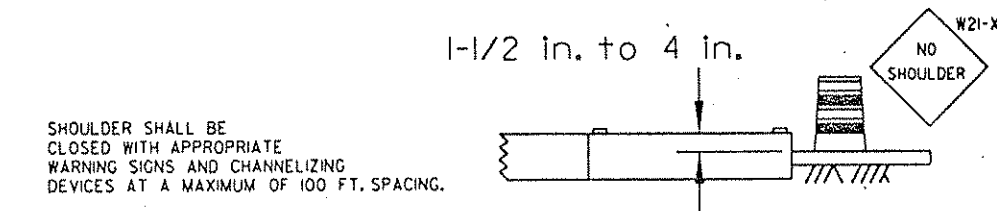
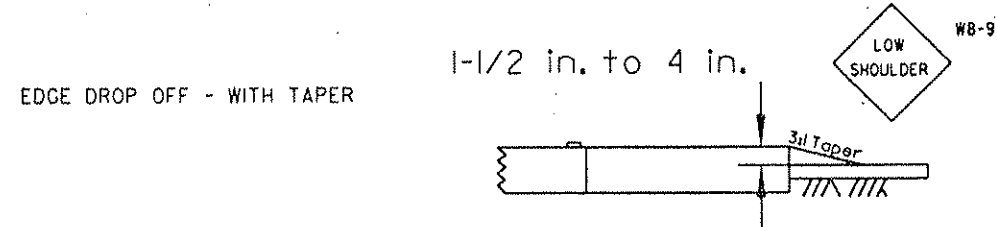
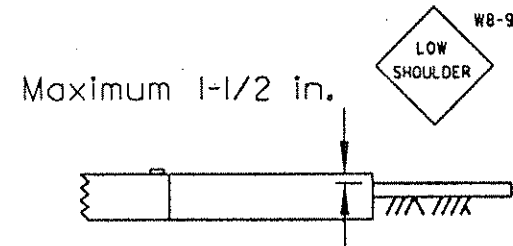

NOTE: SIGNS ARE REQUIRED ONLY ON THE SIDE OF THE ROAD THAT IS AFFECTED BY CONSTRUCTION (EXCEPT SIGNS THAT ARE FOR A LANE CLOSURE ON DIVIDED HIGHWAYS).

**UNEVEN LANES**

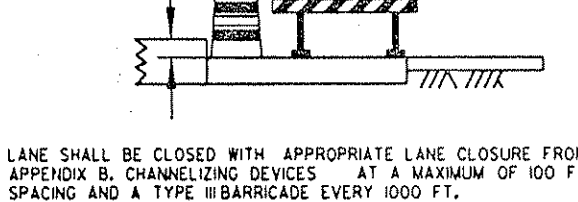
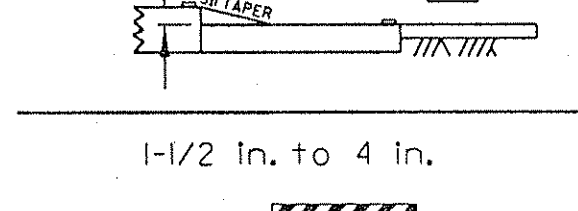
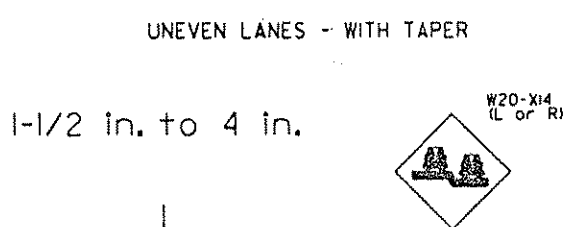
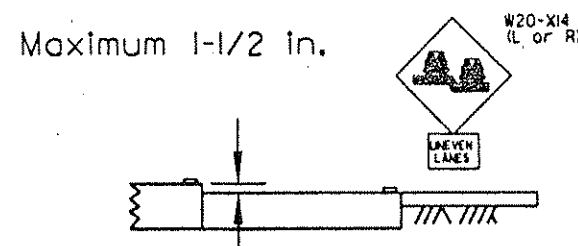

LANE SHALL BE CLOSED WITH APPROPRIATE LANE CLOSURE FROM APPENDIX B. CHANNELIZING DEVICES AT A MAXIMUM OF 100 FT. SPACING AND A TYPE III BARRICADE EVERY 1000 FT.

NOTE: FOR DIVIDED HIGHWAYS, USE SIGNS ON RIGHT AND LEFT SIDE. SIGN SEQUENCE SHOWN FOR ONE DIRECTION ONLY; OTHER DIRECTION SHALL BE IDENTICAL.

**MILLED EDGE**

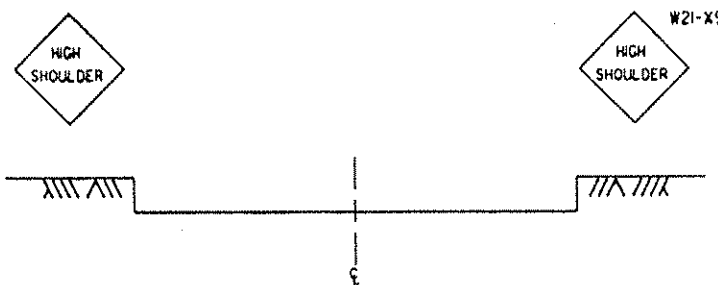

NOTE: MILLED EDGES SHOULD BE TREATED WITH TAPERS, CHANNELIZERS, AND SIGNING AS SHOWN ON EDGE DROP-OFF DETAILS.

NOTE: ALL TRAFFIC CONTROL DEVICES AND SIGNING SHALL CONFORM TO THE MMUTCD, INCLUDING APPENDIX B, DATED NOVEMBER 1992.

**GUIDELINES**

THESE GUIDELINES ARE INTENDED TO INCREASE TRAFFIC SAFETY USING TRAFFIC CONTROL DEVICES, SAFETY RELATED APPURTENANCES, AND CONSTRUCTION TECHNIQUES FOR UNEVEN LANES, MILLED EDGES, AND EDGE DROP-OFFS THAT OCCUR IN HIGHWAY WORK ZONES. THE BEST WAY TO INCREASE TRAFFIC SAFETY IS TO MAKE EVERY ATTEMPT TO MINIMIZE EXPOSURE TO UNEVEN LANES, MILLED EDGES, AND EDGE DROP-OFFS; HOWEVER, IT IS REALIZED THAT THIS IS OFTEN NOT POSSIBLE OR FEASIBLE. ONLY WHEN UNEVEN LANES, MILLED EDGES, OR EDGE DROP-OFFS ARE DEEMED NECESSARY, SHALL THE APPROPRIATE PORTION(S) OF THESE GUIDELINES BE APPLIED TO ENHANCE TRAFFIC SAFETY.

APPROPRIATE UNEVEN LANE WARNING SIGNS OR SHOULDER WARNING SIGNS SHALL BE REPEATED AFTER EACH INTERSECTION.

MAXIMUM WARNING SIGN SPACING SHALL BE:  
 A - 1 MILE WHEN THE SPEED LIMIT IS GREATER THAN 30 MPH AND  
 B - 1/4 MILE WHEN THE SPEED LIMIT IS 30 MPH OR LESS.

WHEN SPACE PERMITS, MINIMUM WARNING SIGN SIZE SHALL BE:  
 A - 48 INCHES x 48 INCHES WHEN THE SPEED LIMIT IS GREATER THEN 30 MPH AND  
 B - 36 INCHES x 36 INCHES WHEN THE SPEED LIMIT IS 30 MPH OR LESS.

1. FOR DROP-OFFS OF 1-1/2 INCHES OR LESS, APPROPRIATE WARNING SIGNS SHALL BE PROVIDED.
2. FOR DROP-OFFS GREATER THAN 1-1/2 INCHES UP TO 4 INCHES:
  - A - THE EDGE SHALL BE TAPERED AND COMPACTED AT A RATE OF 3:1 AND APPROPRIATE WARNING SIGNS SHALL BE PROVIDED; OR
  - B - IF THE TAPER IS NOT PROVIDED, TRAFFIC SHALL NOT BE PERMITTED TO CROSS THE DROP-OFF AND THAT PORTION OF THE ROADWAY SHALL BE CLOSED TO TRAFFIC WITH THE APPROPRIATE WARNING SIGNS AND DEVICES.
3. FOR DROP-OFFS GREATER THAN 4 INCHES UP TO 12 INCHES:
  - A - THE EDGE SHALL BE TAPERED AND COMPACTED AT A RATE OF 6:1 AND APPROPRIATE WARNING SIGNS SHALL BE PROVIDED, (6:1 TAPER SHALL NOT BE USED AS A TRAFFIC CARRYING LANE);
  - B - THE EDGE SHALL BE TAPERED AND COMPACTED AT A RATE OF 3:1, TRAFFIC SHALL NOT BE ALLOWED TO CROSS THE DROP-OFF, AND THAT PORTION OF THE ROADWAY SHALL BE CLOSED TO TRAFFIC WITH APPROPRIATE WARNING SIGNS AND CHANNELIZING DEVICES; OR
  - C - IF A TAPER IS NOT PROVIDED, THE TRAFFIC OR AUXILIARY LANE ADJACENT TO THE DROP-OFF SHALL BE CLOSED TO TRAFFIC WITH THE APPROPRIATE WARNING SIGNS AND CHANNELIZING DEVICES OR A POSITIVE BARRIER, SUCH AS A PORTABLE PRECAST CONCRETE BARRIER, SHALL BE PROVIDED TO PREVENT TRAFFIC FROM CROSSING THE DROP-OFF.
4. FOR SHOULDER EDGE DROP-OFFS:
  - A - 0-2 FOOT SHOULDER WIDTH AND A 0-12 INCH DROP-OFF; USE GUIDELINES AS SHOWN
  - B - 2-8 FOOT SHOULDER WIDTH AND A 0-4 INCH DROP-OFF; INSTALL EDGELINE OR USE GUIDELINES AS SHOWN
  - C - 8 FOOT OR GREATER SHOULDER WIDTH AND A 0-4 INCH DROP-OFF; NO TRAFFIC CONTROL REQUIRED
  - D - GREATER THAN 2 FOOT SHOULDER WIDTH AND A 4-12 INCH DROP-OFF; USE GUIDELINES AS SHOWN
5. DROP-OFFS GREATER THAN 4 INCHES ADJACENT TO TRAFFIC CARRYING LANES ARE PERMITTED WITHOUT TAPERS OR POSITIVE BARRIERS FOR:
  - A - PROJECTS WITHIN URBAN AREA WHEN THE SPEED LIMIT IS 30 MPH OR LESS; OR
  - B - SHORT TERM (7 CALENDAR DAYS OR LESS) CONCRETE OR UTILITY REPAIR, LESS THAN 50 FEET IN LENGTH WHEN THE SPEED LIMIT IS GREATER THAN 30 MPH.
6. AT NO TIME SHALL THERE BE MORE THAN ONE UNEVEN LANE CONDITION BETWEEN THE TRAFFIC CARRYING LANES WHICH INCLUDE AUXILIARY LANES, TURN LANES, AND RAMP ACCESS OR EGRESS AREAS. WEATHER PERMITTING, ALL EXPOSED UNEVEN LANES CONDITIONS WITHIN THE TRAFFIC CARRYING LANES SHALL BE 'MATCHED' WITHIN 24 HOURS.
7. MILLING OPERATIONS SHALL BE REQUIRED TO COMPLETE THE FULL WIDTH OF THE SECTION UNDER CONSTRUCTION AT THE END OF EACH WORK PERIOD.

Traffic Control Treatment of  
 Longitudinal Joints and  
 Edge Drop-offs in Work Zones