

**STATEMENT OF ESTIMATED QUANTITIES**

**CR 28 2/22/2013**

ITEM NO.		ITEM	TAB	NOTE NO.	UNIT	TOTAL EST. QUANT.	UNIT PRICE	COST EST.
2021.501	00010	MOBILIZATION			LUMP SUM	1	\$19,340.36	\$19,340.36
2104.501	00010	REMOVE PIPE CULVERTS	A	1	LIN FT	533	\$9.80	\$5,223.40
2104.501	00024	REMOVE CONCRETE CURB	B	2	LIN FT	62	\$8.00	\$496.00
2104.503	00021	REMOVE CONCRETE WALK	C	3	SQ FT	392	\$1.46	\$572.32
2104.503	00024	REMOVE CONCRETE DRIVEWAY PAVEMENT	D	4	SQ FT	659	\$0.90	\$593.10
2104.505	00119	REMOVE BITUMINOUS DRIVEWAY PAVEMENT	E	5	SQ YD	879	\$2.83	\$2,487.57
2104.505	00120	REMOVE BITUMINOUS PAVEMENT	F	6	SQ YD	907	\$5.66	\$5,131.73
2104.511	00011	SAW CONCRETE PAVEMENT FULL DEPTH	G	7	LIN FT	62	\$4.17	\$258.54
2104.513	00011	SAW BITUMINOUS PAVEMENT FULL DEPTH	H	7	LIN FT	652	\$2.83	\$1,845.16
2104.523	00543	SALVAGE SIGN TYPE TYPE C			EACH	19	\$45.55	\$865.45
2105.501	00010	COMMON EXCAVATION ( P )	I	8	CU YD	436	\$4.05	\$1,764.60
2105.525	00010	TOPSOIL BORROW ( LV )	J	10	.CU YD	622	\$18.36	\$11,424.00
2105.602	00020	CONSTRUCT TURN LANE (233.RD.NB) ( P )		9	EACH	1	\$7,532.36	\$7,532.36
2105.602	00020	CONSTRUCT TURN LANE (233.RD.SB) ( P )		9	EACH	1	\$9,918.94	\$9,918.94
2105.602	00020	CONSTRUCT TURN LANE ( MN 47 ) ( P )		9	EACH	1	\$12,816.89	\$12,816.89
2105.602	00020	CONSTRUCT BYPASS LANE ( STARK AVE ) ( P )		9	EACH	1	\$9,918.94	\$9,918.94
2123.503	00010	MOTOR GRADER	K	11	HOUR	40	\$130.74	\$5,229.60
2130.501	00010	WATER		12	M-GAL	94	\$19.89	\$1,869.66
2211.501	00050	AGGREGATE BASE CLASS 5 ( P )	L	13	TON	980	\$10.43	\$10,224.88
2221.501	00050	AGGREGATE SHOULDERING CLASS 5	M	14	TON	850	\$13.24	\$11,255.06
2232.501	00050	MILL BITUMINOUS SURFACE (2") JOINTS	N	15	SQ YD	143	\$6.69	\$954.44
2331.604	00060	BITUMINOUS PAVEMENT RECLAMATION FULL DEPTH	O	16	SQ YD	18109	\$1.11	\$20,100.99
2331.607	00010	HAUL BIT PAVEMENT RECLAMATION (LV)	P	8	CU YD	545	\$6.00	\$3,267.78
2357.502	00010	BITUMINOUS MATERIAL FOR TACK COAT	Q	17	GALLON	1110	\$2.37	\$2,629.60
2360.501	24500	TYPE SP 12.5 WEARING COURSE MIX ( 4 , E )	R	18	TON	4855	\$56.33	\$273,478.06
2360.501	24200	TYPE SP 12.5 WEARING COURSE MIX ( 4 , B ) STREETS	S	19	TON	83	\$93.18	\$7,742.63
2360.501	24200	TYPE SP 12.5 WEARING COURSE MIX ( 4 , B ) DRIVEWAYS	S	19	TON	101	\$93.18	\$9,414.34
2451.509	00010	AGGREGATE BEDDING ( LV )	T	20	CU YD	19	\$25.00	\$478.44
2501.511	20150	15" CS PIPE CULVERT	U	42	LIN FT	384	\$25.00	\$9,600.00
2501.515	90240	24" RC PIPE APRON	V	21	EACH	2	\$700.00	\$1,400.00
2501.515	01936	36" RC PIPE APRON	W	22	EACH	2	\$1,000.00	\$2,000.00
2501.521	90222	22" SPAN RC PIPE-ARCH CULV CL IIA	X	43	LIN FT	8	\$97.00	\$776.00
2501.525	90220	22" SPAN RC PIPE-ARCH APRON	Y	43	EACH	1	\$441.00	\$441.00
2501.561	90243	24" RC PIPE CULVERT DES 3006 CL III	Z	21	LIN FT	72	\$25.64	\$1,846.08
2501.561	90363	36" RC PIPE CULVERT DES 3006 CL III	AA	22	LIN FT	112	\$45.80	\$5,129.60
2501.567	04150	15" GS SAFETY APRON & GRATE DES 3148	BB	42	EACH	24	\$502.00	\$12,048.00
2504.602	00032	ADJUST GATE VALVE & BOX	CC	23	EACH	5	\$285.00	\$1,425.00
2506.516	00010	CASTING ASSEMBLY	DD	23	EACH	6	\$550.00	\$3,300.00
2506.522	00010	ADJUST FRAME & RING CASTING	EE	23	EACH	6	\$318.00	\$1,908.00
2511.501	00012	RANDOM RIPRAP CLASS II	FF	24	CU YD	35	\$99.90	\$3,541.94
2511.515	00014	GEOTEXTILE FILTER TYPE IV	GG	25	SQ YD	120	\$3.00	\$361.33
2521.501	00060	6" CONCRETE WALK	HH	26	SQ FT	240	\$3.75	\$900.00
2531.501	02080	CONCRETE CURB & GUTER DESIGN B418	II	27	LIN FT	1590	\$16.25	\$25,837.50
2531.507	00060	6" CONCRETE DRIVEWAY PAVEMENT	JJ	28	SQ YD	76	\$90.00	\$6,840.00
2531.618	00010	TRUNCATED DOMES	KK	29	SQ FT	24	\$34.61	\$830.64
2540.602	00140	INSTALL MAIL BOX SUPPORT	LL	30	EACH	40	\$105.00	\$4,200.00
2540.602	00155	RELOCATE MAILBOX SUPPORT	MM	31	EACH	23	\$92.54	\$2,128.42
2563.601	00010	TRAFFIC CONTROL		32	LUMP SUM	1	\$2,835.23	\$2,835.23
2563.601	00200	DETOUR SIGNING		33	LUMP SUM	1	\$10,227.00	\$10,227.00
2563.613	01100	PORTABLE CHANGEABLE MESSAGE SIGN		34	UNIT DAY	14	\$150.00	\$2,100.00
2564.533	00130	FURNISH SIGN PANEL TYPE C		41	SQ FT	43.75	\$33.53	\$1,466.94
2564.536	00013	INSTALL SIGN PANEL TYPE C		41	EACH	19	\$95.56	\$1,815.84
2573.508	00010	BITUMINOUS LINED FLUME	NN	35	SQ YD	60	\$22.86	\$1,371.60
2573.502	00040	SILT FENCE TYPE MACHINE SLICED	OO	36	LIN FT	4174	\$1.37	\$5,718.38
2573.602	00090	CULVERT PROTECTION	PP	44	EACH	11	\$150.00	\$1,650.00
2575.505	00050	SODDING TYPE SALT RESISTANT	QQ	44	SQ YD	427	\$2.86	\$1,221.22
2575.523	00010	EROSION CONTROL BLANKET CATEGORY 00	RR	37	SQ YD	7278	\$2.00	\$14,556.44
2575.571	00010	RAPID STABILIZATION METHOD 3	SS	38	MGAL	8.2	\$242.00	\$1,996.00
2581.501	00010	REMOVABLE PREFORMED PLASTIC MARKING	TT	39	LIN FT	200	\$1.50	\$299.40
2582.502	21112	12" WHITE PREF THERMOPLASTIC		40	LIN FT	85	\$10.65	\$905.25
2582.502	21124	24" WHITE PREF THERMOPLASTIC		40	LIN FT	43	\$18.65	\$801.95
2582.502	41104	4" SOLID LINE WHITE - EPOXY		40	LIN FT	10103	\$0.22	\$2,222.66
2582.502	41204	4" BROKEN LINE WHITE-EPOXY		40	LIN FT	40	\$0.22	\$8.80
2582.502	42104	4" SOLID LINE YELLOW - EPOXY		40	LIN FT	1102	\$0.24	\$264.48
2582.502	42204	4" BROKEN LINE YELLOW-EPOXY		40	LIN FT	570	\$0.24	\$136.80
2582.502	42404	4" DOUBLE SOLID LINE YELLOW - EPOXY		40	LIN FT	2126	\$0.46	\$977.96
							TOTAL	\$571,922.10

PLAN SYMBOLS

- COUNTY LINE
- TOWNSHIP OR RANGE LINE
- SECTION LINE
- QUARTER LINE
- SIXTEENTH LINE
- RIGHT OF WAY LINE
- SLOPE EASEMENT
- EXISTING RIGHT OF WAY
- PROPERTY LINE
- CORPORATE OR CITY LIMITS
- RETAINING WALL
- RAILROAD
- RAILROAD RIGHT OF WAY
- RIVER OR CREEK
- DRAINAGE DITCH
- CULVERT
- DROP INLET
- GUARD RAIL
- BARBED WIRE FENCE
- WOVEN WIRE FENCE
- CHAIN LINK FENCE
- WOOD FENCE
- STONE WALL OR FENCE
- HEDGE

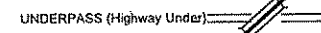
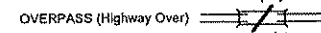

- BUILDING (One Story Frame)
- F-FRAME C-CONCRETE
- S-STONE T-TILE
- B-BRICK ST-STUCCO

- RAILROAD CROSSING BELL
- RAILROAD CROSSING GATE
- MANHOLE
- CATCH BASIN
- FIRE HYDRANT
- CAST IRON MONUMENT
- IRON PIN
- GRAVEL PIT
- SAND PIT
- BORROW PIT
- ROCK QUARRY

UTILITY SYMBOLS

- POWER POLE LINE
- TELEPHONE OR TELEGRAPH POLE LINE
- JOINT TELEPHONE & POWER ON POWER POLES
- ON TELEPHONE POLES
- ANCHOR
- STEEL TOWER
- STREET LIGHT
- PEDESTAL (Cable Terminal)
- GAS MAIN
- WATERMAIN
- TELEPHONE CABLE IN CONDUIT
- ELECTRIC CABLE IN CONDUIT
- TELEPHONE MANHOLE
- ELECTRIC MANHOLE
- BURIED TELEPHONE CABLE
- BURIED ELECTRIC CABLE
- SEWER (Sanitary or Storm)
- SEWER MANHOLE

SCALES

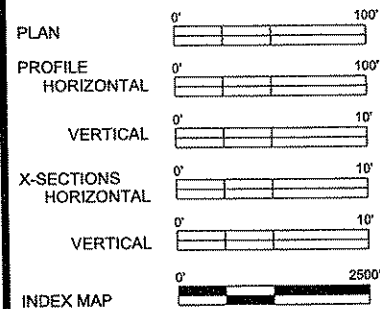

# MINNESOTA DEPARTMENT OF TRANSPORTATION

## ANOKA COUNTY

### CITY OF ST FRANCIS

CONSTRUCTION PLAN FOR RECLAIM AND OVERLAY, RTL / BYPASS CONSTRUCTION, SUBGRADE CORRECTION, AND CONCRETE CURB

LOCATED ON CR 28 FROM CR 24 TO MN 47

	13-16-28		
GROSS LENGTH	4990 FEET	0.95 MILES	
BRIDGES-LENGTH	0.00 FEET	0.00 MILES	
EXCEPTIONS-LENGTH	0.00 FEET	0.00 MILES	
NET LENGTH	4990 FEET	0.95 MILES	

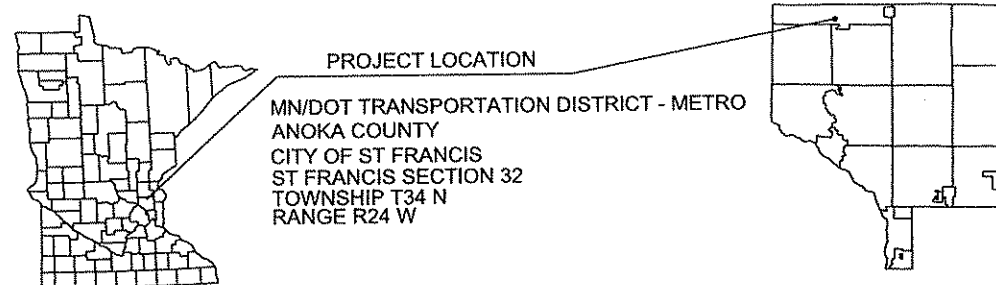
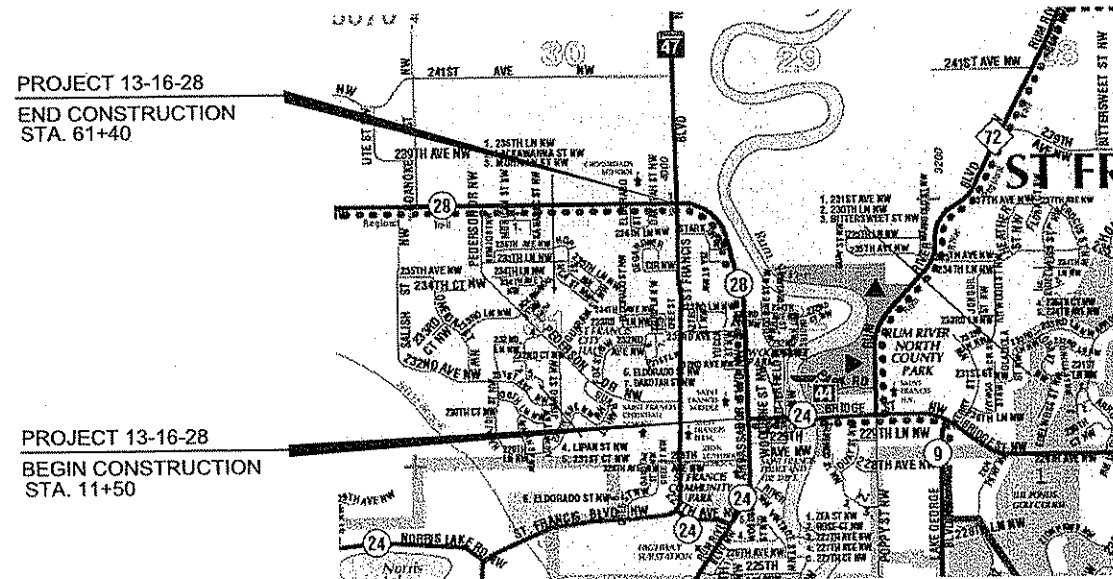

MINN. PROJ. NO. \_\_\_\_\_

GOVERNING SPECIFICATIONS

THE 2005 EDITION OF THE MINNESOTA DEPARTMENT OF TRANSPORTATION "STANDARD SPECIFICATIONS FOR CONSTRUCTION" SHALL GOVERN. ALL TRAFFIC CONTROL DEVICES SHALL CONFORM AND BE INSTALLED IN ACCORDANCE TO THE "MINNESOTA MANUAL ON UNIFORM TRAFFIC CONTROL DEVICES" (MNMUTCD), PART VI, AND THE MOST RECENT EDITION OF THE "FIELD MANUAL FOR TEMPORARY TRAFFIC CONTROL ZONE LAYOUTS."

INDEX

SHEET NO.	DESCRIPTION
1	TITLE SHEET
2	STATEMENT OF ESTIMATED QUANTITIES / NOTES
3 - 5	CONSTRUCTION TABS
6	RTL / BYPASS TAB - STAKING NOTES, CURB AREA
7 - 8	RTL / BYPASS CALCULATIONS
9 - 10	CONSTRUCTION DETAILS
11 - 12	TYPICALS
13	ALIGNMENT / CORE INFORMATION
14 - 15	CONSTRUCTION PLAN
16	PERMANENT MARKING TABULATION
17 - 19	SIGNING AND STRIPING LAYOUTS
20 - 23	SIGNING AND STRIPING DETAILS
24 - 25	DETOUR LAYOUT (SEE SPECIAL PROVISIONS & NOTE #29)

THIS PLAN CONTAINS 25 SHEETS

DESIGN DESIGNATION 13-16-28

ESAL 20	829,769
R VALUE	50
ADT (2010) =	5700
Proj. ADT (2032) =	9559
Proj. HCADT (2032) =	564
Soil Factor	NA
10 TON DESIGN	

Functional Classification A-MINOR CONNECTOR  
 No. of Traffic Lanes 2 No. of Parking Lanes 0  
 Design Speed 35, 40, 45 MPH  
 Based on Stopping Sight Distance ---  
 Height of eye 3.5' Height of object 2.0'  
 Design Speed not achieved at:  
 STA. --- TO STA. --- MPH ---

Approved: 3/14/2013  
 ANOKA COUNTY ENGINEER

NO	DATE	BY	CKD	APPR	REVISION

NAME: P:\13-01-00\CSAH.28\_CSAH24-TH47\1\on\1.TITLE.dwg 2/28/2013 7:00:26 AM

I HEREBY CERTIFY THAT THIS PLAN WAS PREPARED BY ME OR UNDER MY DIRECT SUPERVISION AND THAT I AM A DULY LICENSED PROFESSIONAL ENGINEER UNDER THE LAWS OF THE STATE OF MINNESOTA.  
 PRINT NAME: ANDREW WITTER  
 SIGNATURE:   
 DATE: 3/13/13 LICENSE NO. 42757

DRAWN BY: JF DATE: 2/5/2013  
 DESIGN BY: JF DATE: 2/5/2013  
 CHECKED BY: GA DATE: 2/11/2013

**ANOKA COUNTY**  
**HIGHWAY DEPT.**

STATE PROJECT NO. \_\_\_\_\_  
 STATE AID PROJECT NO. \_\_\_\_\_  
 CITY PROJECT NO. \_\_\_\_\_  
 COUNTY PROJECT NO. CP 13-16-28

TITLE SHEET  
 Sheet 1 of 25 Sheets

STATEMENT OF ESTIMATED QUANTITIES						
ITEM NO.		ITEM	TAB	NOTE NO.	UNIT	TOTAL EST. QUANT.
2021.501	00010	MOBILIZATION			LUMP SUM	1
2104.501	00010	REMOVE PIPE CULVERTS	A	1	LIN FT	533
2104.501	00024	REMOVE CONCRETE CURB	B	2	LIN FT	62
2104.503	00021	REMOVE CONCRETE WALK	C	3	SQ FT	392
2104.503	00024	REMOVE CONCRETE DRIVEWAY PAVEMENT	D	4	SQ FT	659
2104.505	00119	REMOVE BITUMINOUS DRIVEWAY PAVEMENT	E	5	SQ YD	879
2104.505	00120	REMOVE BITUMINOUS PAVEMENT	F	6	SQ YD	907
2104.511	00011	SAW CONCRETE PAVEMENT FULL DEPTH	G	7	LIN FT	62
2104.513	00011	SAW BITUMINOUS PAVEMENT FULL DEPTH	H	7	LIN FT	652
2104.523	00543	SALVAGE SIGN TYPE TYPE C			EACH	19
2105.501	00010	COMMON EXCAVATION ( P )	I	8	CU YD	436
2105.525	00010	TOPSOIL BORROW ( LV )	J	10	CU YD	622
2105.602	00020	CONSTRUCT TURN LANE (233 RD NB ) ( P )		9	EACH	1
2105.602	00020	CONSTRUCT TURN LANE (233 RD SB ) ( P )		9	EACH	1
2105.602	00020	CONSTRUCT TURN LANE ( MN 47 ) ( P )		9	EACH	1
2105.602	00020	CONSTRUCT BYPASS LANE ( STARK AVE ) ( P )		9	EACH	1
2123.503	00010	MOTOR GRADER	K	11	hour	40
2130.501	00010	WATER		12	M-GAL	94
2211.501	00050	AGGREGATE BASE CLASS 5 ( P )	L	13	TON	980
2221.501	00050	AGGREGATE SHOULDERING CLASS 5	M	14	TON	850
2232.501	00050	MILL BITUMINOUS SURFACE (2") JOINTS	N	15	SQ YD	143
2331.604	00060	BITUMINOUS PAVEMENT RECLAMATION FULL DEPTH	O	16	SQ YD	18109
2331.607	00010	HAUL BIT PAVEMENT RECLAMATION (LV)	P	8	CU YD	545
2357.502	00010	BITUMINOUS MATERIAL FOR TACK COAT	Q	17	GALLON	1110
2360.501	24500	TYPE SP 12.5 WEARING COURSE MX ( 4 , E )	R	18	TON	4855
2360.501	24200	TYPE SP 12.5 WEARING COURSE MX ( 4 , B ) STREETS	S	19	TON	83
2360.501	24200	TYPE SP 12.5 WEARING COURSE MX ( 4 , B ) DRIVEWAYS	S	19	TON	101
2451.509	00010	AGGREGATE BEDDING (LV)	T	20	CU YD	19
2501.511	20150	15" CS PIPE CULVERT	U	42	LIN FT	384
2501.515	90240	24" RC PIPE APRON	V	21	EACH	2
2501.515	01936	36" RC PIPE APRON	W	22	EACH	2
2501.521	90222	22" SPAN RC PIPE-ARCH CULV CL II A	X	43	LIN FT	8
2501.525	90220	22" SPAN RC PIPE-ARCH APRON	Y	43	EACH	1
2501.561	90243	24" RC PIPE CULVERT DES 3006 CL III	Z	21	LIN FT	72
2501.561	90363	36" RC PIPE CULVERT DES 3006 CL III	AA	22	LIN FT	112
2501.567	04150	15" GS SAFETY APRON & GRATE DES 3148	BB	42	EACH	24
2504.602	00032	ADJUST GATE VALVE & BOX	CC	23	EACH	5
2506.516	00010	CASTING ASSEMBLY	DD	23	EACH	6
2506.522	00010	ADJUST FRAME & RING CASTING	EE	23	EACH	6
2511.501	00012	RANDOM RIPRAP CLASS II	FF	24	CU YD	35
2511.515	00014	GEOTEXTILE FILTER TYPE IV	GG	25	SQ YD	120
2521.501	00060	6" CONCRETE WALK	HH	26	SQ FT	240
2531.501	02080	CONCRETE CURB & GUTER DESIGN B418	II	27	LIN FT	1590
2531.507	00060	6" CONCRETE DRIVEWAY PAVEMENT	JJ	28	SQ YD	76
2531.618	00010	TRUNCATED DOMES	KK	29	SQ FT	24
2540.602	00140	INSTALL MAIL BOX SUPPORT	LL	30	EACH	40
2540.602	00155	RELOCATE MAILBOX SUPPORT	MM	31	EACH	23
2563.601	00010	TRAFFIC CONTROL		32	LUMP SUM	1
2563.601	00200	DETOUR SIGNING		33	LUMP SUM	1
2563.613	01100	PORTABLE CHANGEABLE MESSAGE SIGN		34	UNIT DAY	14
2564.533	00130	FURNISH SIGN PANEL TYPE C		41	SQ FT	43.75
2564.536	00013	INSTALL SIGN PANEL TYPE C		41	EACH	19
2573.508	00010	BITUMINOUS LINED FLUME	NN	35	SQ YD	60
2573.502	00040	SILT FENCE TYPE MACHINE SLICED	OO	36	LIN FT	4174
2573.602	00090	CULVERT PROTECTION	PP	44	EACH	11
2575.505	00050	SODDING TYPE SALT RESISTANT	QQ	44	SQ YD	427
2575.523	00010	EROSION CONTROL BLANKET CATEGORY 00	RR	37	SQ YD	7278
2575.571	00010	RAPID STABILIZATION METHOD 3	SS	38	MGAL	8.2
2581.501	00010	REMOVABLE PREFORMED PLASTIC MARKING	TT	39	LIN FT	200
2582.502	21112	12" WHITE PREF THERMOPLASTIC		40	LIN FT	85
2582.502	21124	24" WHITE PREF THERMOPLASTIC		40	LIN FT	43
2582.502	41104	4" SOLID LINE WHITE - EPOXY		40	LIN FT	10103
2582.502	41204	4" BROKEN LINE WHITE-EPOXY		40	LIN FT	40
2582.502	42104	4" SOLID LINE YELLOW - EPOXY		40	LIN FT	1102
2582.502	42204	4" BROKEN LINE YELLOW-EPOXY		40	LIN FT	570
2582.502	42404	4" DOUBLE SOLID LINE YELLOW - EPOXY		40	LIN FT	2126

NOTES

- INCLUDES ALL TYPES, SIZES AND APRONS.
- EXISTING CURB RAD. ON 233RD AVE TO BE REMOVED AND ENDS OF EXISTING CURB ON 233RD LN AS TO ALLOW FOR A SMOOTH TRANSITION FOR NEW RAD. IN NEW RIGHT TURN LANES. AS DIRECTED BY THE ENGINEER.
- CONCRETE WALK TO BE REMOVED ON 233RD AVE FOR NEW RIGHT TURN LANE AND FOR INSTALLATION OF TRUNCATED DOMES. DISTANCE BACK ON WALK TO BE DETERMINED BY THE ENGINEER.
- REMOVAL OF CONCRETE DRIVEWAY PAVEMENT WILL BE AT THE DISCRETION OF THE ENGINEER.
- BITUMINOUS ENTRANCES TO BE SAWCUT. BITUMINOUS REMOVED, GRAVEL ADDED AT THE DISCRETION OF THE ENGINEER AND REPAVED.
- PAVEMENT FROM STATION 54+38 - 57+10 TO BE REMOVED FULL DEPTH. PAVEMENT DEPTH VARIES FROM 6" @ BEG AND END STA. TO 2" @ STA. 56+00.
- LOCATION TO BE DETERMINED BY THE ENGINEER.
- STA. 11+50 - 19+00 EXISTING BITUMINOUS TO BE RECLAIMED, STOCKPILED AND PLACED ON FINISHED SUBGRADE. STOCKPIILING OF MATERIAL ALLOWED WITHIN CONSTRUCTION LIMITS OF THIS PROJECT.
- ITEMS INCLUDED IN RTL / BYPASS BY THE EACH ARE , COMMON EXCAVATION, GRANULAR BORROW, TOPSOIL BORROW AND AGG BASE CLASS 5. NOTE - BITUMINOUS ITEMS FOR RTL - BYPASS CONST. ARE INCLUDED IN MAIN SEQ.
- USED BEHIND ALL NEW CURB INSTALLATION, AROUND FLUME AND X-PIPE CONSTRUCTION AND TO TIE IN NEW SH-PI TO EXISTING INSLOPE AS DIRECTED BY ENGINEER.
- INCLUDES TIME AND EQUIPMENT TO REMOVE EXCESS RECLAIMED MATERIAL AT BEG. & END OF RECLAIM AREAS ONLY, - FOR SMOOTH TRANSITION TO EXISTING BITUMINOUS. FINAL SHAPING AND MAINTNANCE OF RECLAIMED ROADWAY INCIDENTAL TO ITEM.
- WATER TO BE USED AS DUST CONTROL , AT THE DISCRETION OF THE ENGINEER.
- MATERIAL TO BE USED FOR ROAD BASE STA. 11+50 - 19+00.
- SHOULDERING CLASS 5 FOR FINISHED 2" GRVL. SHLDR. (CALC. AT 4" DEPTH) AND ALL ENTRANCES. (3 TONS - BIT/CONC DR.WAYS AND 7 TONS FOR GRAVEL ENT. / FIELD ENT.)
- 2" DEEP BY 4' WIDE MILL AT BEGINNING AND END OF PROJECT AND ALL PAVED ST APPROACHES.
- FULL DEPTH RECLAMATION FROM STA 11+50 TO STA. 54+38 AND STA. 57+10 TO STA. 61+40. EXCESS RECLAIMED BITUMINOUS FROM 11+50 TO 19+00 MAY BE USED TO REPLACE BITUMINOUS BEING REMOVED STA 54+38 TO 57+10.
- TACK TO BE USED ON ALL BASE COURSE, MILL JOINTS, DRIVEWAY SAWCUTS AND AGAINST NEW CURB.
- MAINLINE TOP COURSE 2" ( SPWEB440 E ) TOP WEARING SURFACE. ITEM INCLUDES CONST. OF SAFETY EDGE. REFER TO SPECIAL PROV. MAINLINE BOTTOM COURSE 2" ( SPWEB440 E ) PLACED ON RECLAIMED GRAVEL SURFACE.
- STREET APPROACH / DR WAY BITUMINOUS 2" ( SPWEB440 B ) PAVED IN SEPARATE OPERATION PRIOR TO MAINLINE PAVING.
- AGGREGATE BEDDING USED FOR X-PIPE INSTALLATION IN WET AREAS, AS DIRECTED BY THE ENGINEER.
- STA 42+90 , 24" X-PIPE LENGTH MAY CHANGE IF BYPASS IS NOT CONSTRUCTED, INVERTS TO BE INSTALLED AT EXISTING ELEV. REFER TO PLAN SHEET FOR DETAILS.
- STA 54+20 , 36" X- PIPE . IN SAG AREA WHERE BITUMINOUS IS TO BE REMOVED, INVERTS TO BE AT EXISTING ELEV. REFER TO PLAN SHEET FOR DETAILS.
- INPLACE SANITARY MYS TO BE ADJUSTED TO NEW BITUMINOUS ELEV / SHOULDER ELEV. IN NEW RTL / BYPASS LOCATIONS.
- RIPRAP CLASS II TO BE PLACED AT APRON ENDS OF CROSS PIPES AND FLUMES. AREA TO BE COVERED IN RIPRAP TO BE AT THE DISCRETION OF THE ENGINEER.
- GEOTEXTILE FILTER TO BE PLACED UNDER RIP RAP.
- 233RD AVE IN RAD. FOR TRUNCATED DOME INSTALLATION.
- INSTALLED STA. 11+50 - 19+00 AND BOTH RAD. OF 233RD AVE. CONTRACTOR TO COORDINATE WITH HOME OWNERS IN EFFECTED AREA FOR CLOSING DRIVEWAYS.
- LOCATION AND AREA OF DRIVEWAY CONCRETE TO BE DETERMINED BY THE ENGINEER. CONTRACTOR TO COORDINATE WITH HOME OWNERS IN EFFECTED AREA FOR CLOSING DRIVEWAYS. SHLDR CL-5 TO BE USED TO ADJUST GRADE BEFORE PLACEMENT OF CONC. SAWCUT REQUIRED FOR CLEAN EDGE TO PAVE TO.
- RADIAL DOME PANELS TO BE INSTALLED IN SIDEWALKS ON 233RD AVE AND MEET ADA REQUIREMENTS. COLOR TO TO BE DETERMINED BY THE ENGINEER.
- MAILBOXES TO BE INSTALLED AT THE EXISTING MAILBOX LOCATION. MAILBOX MATERIALS INCIDENTAL TO INSTALLATION. CONTRACTORS RESPONSIBILITY TO COORDINATE WITH LOCAL POSTAL AUTHORITY.
- MAILBOXES AFFECTED IN CURB CONSTRUCTION AREA AND RTL / BYPASS CONSTRUCTION TO BE RELOCATED FOR CONSTRUCTION. CONTRACTORS RESPONSIBILITY TO COORDINATE WITH LOCAL POSTAL AUTHORITY.
- \* ALL TRAFFIC CONTROL METHODS SHALL CONFORM TO THE MINNESOTA MANUAL ON UNIFORM TRAFFIC CONTROL DEVICES. " DO NOT PASS, PASS WITH CARE AND NO CENTER STRIPE SIGNS TO BE INPLACE DURING RECLAIMING / PAVING OPERATIONS. WORK NOT TO BEGIN BEFORE JUNE 17 TH. DETOUR LAYOUT PROVIDED IN THIS PLAN.
- 2 - MESSAGE BOARDS, ONE ON EACH END OF PROJECT WILL BE INSTALLED 7-DAYS PRIOR TO ANY CONSTRUCTION. REFERENCE " TRAFFIC CONTROL QUANTITIES" SECTION OF THIS PLAN FOR DETAILS.
- MATERIAL TO BE ADDED TO EXISTING FLUMES TO MATCH NEW ROAD SURFACE AND TO EXTEND FLUMES TO BOTTOM OF DITCH. ADDITIONAL FLUMES TO BE CONSTRUCTED AS NEEDED AND DIRECTED BY THE ENGINEER. BIT. TACK REQUIRED WILL BE INCIDENTAL. PLACE RIPRAP AND GEOTEXTILE AT FLUME ENDS IF POSSIBLE, AS DIRECTED BY THE ENGINEER.
- INSTALL SILT FENCE SURROUNDING DISTURBED AREAS AROUND CROSS PIPE APRON ENDS AND FLUME CONSTRUCTION. AS DIRECTED BY THE ENGINEER.
- EROSION CONTROL BLANKET CAT. 00 TO BE INSTALLED AROUND X-PIPE APRON ENDS AND 1 ROW OF BLANKET ON LOW SIDE OF SUPER AND BEHIND CURB INSTALLATION. PLACEMENT, SEED AND FERTILIZER INCIDENTAL TO BLANKET. SEED MIXTURE 250 ( RATE - 70 LBS PER ACRE ) AND FERTILIZER TYP 3 ( RATE - 350 LBS PER ACRE )
- PLACEMENT, SEED AND FERTILIZER INCIDENTAL TO RAPID STABILIZATION METHOD 3. SEED MIXTURE 250 ( RATE - 70 LBS PER ACRE ) AND FERTILIZER TYP 3 ( RATE - 350 LBS PER ACRE ) RAPID STABILIZATION METHOD 3 TO BE APPLIED AT A RATE OF 6 M-GAL PER ACRE. ITEM PAID FOR BY THE MGAL.
- CL YLW SKIPS TO BE APPLIED BY THE END OF THE DAYS PAVING. THE CONTRACTOR WILL REMOVE ALL C/L SKIPS PRIOR TO THE FINAL PAINT STRIPING.
- PERMANENT MARKINGS TO BE IN PLACE WITHIN 72 HOURS OF FINAL WEAR COURSE PAVING.
- NEW POSTS AND HARDWEAR TO INSTALL INCIDENTAL TO ITEM
- DRIVEWAY CULVERTS AFFECTED BY RTL / BYPASS CONSTRUCTION, REMOVED-REPLACED AS DIRECTED BY THE ENGINEER.
- REMOVE APRON / EXTEND 22" ARCH PIPE S.E. CORNER OF 233RD LN AND CR 28.
- AS DIRECTED BY THE ENGINEER.

NO	DATE	BY	CHKD	APPR	REVISION
NAME: P:\13-01-00\CSAH_28_(CSAH24-TH47)\Plan\2_SEO.dgn					

I HEREBY CERTIFY THAT THIS PLAN WAS PREPARED BY ME OR UNDER MY DIRECT SUPERVISION AND THAT I AM A DULY LICENSED PROFESSIONAL ENGINEER UNDER THE LAWS OF THE STATE OF MINNESOTA.

PRINT NAME: ANDREW WITTER

SIGNATURE: *[Signature]*

DATE: 2/15/2013 LICENSE NO. 42757

DRAWN BY: JF DATE: 2/5/2013

DESIGN BY: JF DATE: 2/5/2013

CHECKED BY: GA DATE: 2/11/2013

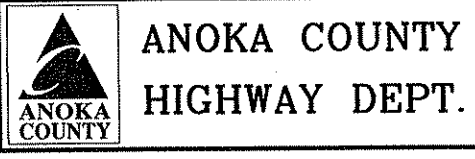

STATE PROJECT NO. \_\_\_\_\_

STATE AID PROJECT NO. \_\_\_\_\_

CITY PROJECT NO. \_\_\_\_\_

COUNTY PROJECT NO. CP 13-16-28

A REMOVE PIPE CULVERTS		
LOCATION		LIN FT
NB	23947	30
NB	23255	20
NB	23263	24
NB	23267	24
NB	233RD LN	8
SB	23326	30
SB	23344	30
SB	23356	30
SB	23376	22
NB	23519	40
NB	23539	55
NB	F.E. 60+00	30
STA		
	42+90	67
	54+45	123
TOTAL LIN FT		533

B REMOVE CONCRETE CURB		
LOCATION		LIN FT
SB	28+50	47
NB	30+80	15
TOTAL LIN FT		62

C REMOVE CONCRETE WALK		
LOCATION		SQ FT
SB	28+50	196
SB	29+00	196
TOTAL SQ FT		392

D REMOVE CONC. DR.WAY PAVEMENT		
LOCATION		SQ FT
NB	23021	121
NB	23339	60
NB	23347	128
NB	23637	273
NB	23647	77
TOTAL SQ FT		659

E REMOVE BITUMINOUS DR.WAY PAVEMENT		
LOCATION		SQ YDS
SB	N. SCHOOL ENT	76
SB	23122	21
NB	23125	19
SB	23216	24
SB	23224	17
NB	23223	22
SB	23232	24
NB	23231 / 23239	49
SB	23240	25
SB	23250	36
NB	23247	25
NB	23263	29
NB	23267	28
SB	23326	26
SB	23344	25
SB	23356	36
NB	23339	12
SB	23376	41
NB	23347	6
SB	3845	90
NB	23355	20
SB	23390	21
NB	23539	24
NB	23555	30
NB	23611	22
NB	23647	16
NB	23655	23
NB	LIFT STA.	29
SB	23671	62
TOTAL SQ YDS		879

F REMOVE BITUMINOUS PAVEMENT		
LOCATION		SQ YDS
	54+38 - 57+10 (30' WDE)	907
TOTAL SQ YDS		907

G SAW CONCRETE PAVEMENT FULL DEPTH		
LOCATION		LIN FT
NB	23045	10
NB	23339	11
NB	23347	12
NB	23637	17
NB	23647	12
TOTAL LIN FT		62

H SAW BITUMINOUS PAVEMENT FULL DEPTH		
LOCATION		LIN FT
BEG	11+50	40
SB	S.SCHOOL	50
SB	N.SCHOOL	43
SB	23122	12
NB	23125	19
SB	23216	14
SB	23224	11
NB	23223	12
SB	23232	18
NB	23231 / 23239	29
SB	23240	16
SB	23250	20
NB	23247	19
SB	233 AVE	35
NB	23263	12
NB	23267	11
SB	23326	10
NB	233RD LN	28
SB	23344	9
SB	23356	18
NB	23339	0
SB	23376	22
NB	23347	0
NB	23355	12
SB	23390	11
NB	23539	17
SB	3845	70
NB	23555	20
NB	23611	12
NB	23647	0
NB	23655	12
NB	LIFT STA.	20
SB	23671	30
TOTAL LIN FT		652

I COMMON EXCAVATION							
MAINLINE	STATION	STATION	LENGTH	WIDTH	AVG. DEPTH	CU YDS	
	11+50	17+70	620.0	38.00	0.4	349	
	17+70	19+00	130.0	45.00	0.4	87	
						TOTAL CU YDS	436

J TOPSOIL BORROW							
MAINLINE	STATION	STATION	LENGTH	WIDTH	DEPTH	CU FT	CU YDS
NB	11+50	19+00	750.00	10.00	0.40	3000.00	111
SB	11+50	19+00	750.00	10.00	0.40	3000.00	111
NB	19+00	61+40	4240.00	6.00	4" - 0"	4240.00	157
SB	19+00	61+40	4240.00	6.00	4" - 0"	4240.00	157
NB	FLUME	19+00	20.00	10.00	0.40	80.00	3
SB	FLUME	19+00	20.00	10.00	0.40	80.00	3
SB	FLUME	20+70	20.00	10.00	0.40	80.00	3
SB	FLUME	21+20	20.00	10.00	0.40	80.00	3
SB	233RD AVE	28+50	20.00	10.00	0.40	80.00	3
SB	233RD AVE	29+00	20.00	10.00	0.40	80.00	3
SB	FLUME	45+70	20.00	10.00	0.40	80.00	3
SB	FLUME	46+20	20.00	10.00	0.40	80.00	3
SB	X-PPE	42+90	20.00	20.00	0.40	160.00	6
NB	X-PPE	42+90	20.00	20.00	0.40	160.00	6
SB	X-PPE	54+15	40.00	40.00	0.40	640.00	24
NB	X-PPE	54+15	40.00	40.00	0.40	640.00	24
SB	FLUME	58+20	20.00	10.00	0.40	80.00	3
						TOTAL CU YDS	622

K MOTOR GRADER		
LOCATION		HRS
	11+50 - 23+00	24
	54+38 - 57+10	8
	58+40 - 61+40	8
TOTAL HOURS		40

L AGGREGATE BASE CLASS 5							
MAINLINE	STATION	STATION	LENGTH	WIDTH	DEPTH	CU YDS	TONS
	11+50	17+70	620.0	38.0	0.50	436.3	785
	17+70	19+00	130.0	45.0	0.50	108.3	195
						TOTAL TONS	980

M AGGREGATE SHLDR CL- 5 ( INC ALL DR WAYS.)							
MAINLINE	STATION	STATION	LENGTH	WIDTH	4" DEPTH	CU YDS	
NB	19+00	61+40	4240.0	3.0	0.33	155	
SB	19+00	61+40	4240.0	3.0	0.33	155	
						SUB TOTAL CU YDS	311

SUBTRACT ST. OPENINGS				SHLDR W			
	232 ND		100.0	2.0	0.33	2	
	233RD AVE		100.0	2.0	0.33	2	
	233RD LN		100.0	2.0	0.33	2	
	STARK AVE		100.0	2.0	0.33	2	
						SUBTRACT ST OPEN	10
						SHLDR CU YDS	311
						SUBTRACT ST. OPENINGS	10
						CU YDS	301
						GRVL FACTOR	1.8
						TONS	542

ADD GRAVEL FOR ALL DR WAYS							
	NB	3765	G			7	
	NB	23021	G			7	
	SB	N.SCH	B			3	
	NB	23037	G			7	
	NB	23045	C			3	
	SB	23100	G			7	
	NB	23105	G			7	
	SB	23112	G			7	
	SB	23122	B			3	
	NB	23125	B			3	
	NB	23169	G			7	
	NB	23215	G			7	
	SB	23216	B			3	
	SB	23224	B			3	
	NB	23223	B			3	
	SB	23232	B			3	
	NB	23231	B			3	
	SB	23240	B			3	
	SB	23250	B			3	
	NB	23247	B			3	
	NB	23255	G			7	
	NB	23263	B			3	
	NB	23267	B			3	
	SB	23326	B			3	
	SB	23344	B			3	
	SB	23356	B			3	
	NB	23339	BC			3	
	SB	23376	B			3	
	NB	23347	BC			3	
	NB	23355	B			3	
	SB	23390	B			3	
	NB	FE	G			7	
	SB	FE	G			7	
	NB	23519	G			7	
	NB	23539	B			3	
	SB	3845	B			3	
	NB	23555	B			3	
	NB	23601	G			7	
	NB	23611	B			3	
	NB	23637	C			3	
	NB	23647	BC			3	
	NB	23655	B			3	
	NB	LIFT STA.	B			3	
	SB	23671	B			3	
						TOTAL TONS	726

N MILL BITUMINOUS SURFACE 2" ( JOINTS )					
LOCATION	STATION	LENGTH	WIDTH	SQ YDS	
MAINLINE	11+50	40.00	4.0	18	
MAINLINE	61+40	141.00	4.0	53	
BIT STREETS					
	232ND	32.00	4.0	14	
	233RD AVE	34.00	4.0	15	
	233RD LN	30.00	4.0	13	
	STARK DR	44.00	4.0	20	
				TOTAL SQ YDS	143

O BITUMINOUS PAVEMENT RECLAMATION			
LOCATION		MICRO	
	STA. 11+50 - 54+38 AND 57+10 - 61+40	18109	
		TOTAL SQ YDS	18109

P HAUL BIT PAVEMENT RECLAMATION						
STA	LENGTH	WIDTH	DEPTH	CU FT	CU YD	
11+50 - 17+70	620.00	38.00	0.5	11780	436	
17+70 - 19+00	130.00	45.00	0.5	2925	108	
					TOTAL CU YDS	545

Q BITUMINOUS MATERIAL FOR TACK				
LOCATION		SQ YDS	GAL/SQYD	
	11+50 - 61+40	21397.7	0.05	1070
BIT ST APP				
	232ND	219	0.05	11
	233RD AVE	200	0.05	10
	233RD LN	200	0.05	10
	STARK DR	174	0.05	9
			TOTAL GAL	1110

R TYPE SP 12.5 WEARING COURSE MIX ( SPWEB440 E )			
MAINLINE ( TOP SURFACE ) MICRO	SQ YDS		
STA 11+50 - 61+40	20819		
MAINLINE ( BOTTOM SURFACE ) MICRO			
STA 11+50 - 61+40	21398		
TOTAL SQ YDS		42217	
( SQ YDS X 2' X 115LBS / 2000 )		TOTAL TONS	4855

NO	DATE	BY	CHK	APPR	REVISION

I HEREBY CERTIFY THAT THIS PLAN WAS PREPARED BY ME OR UNDER MY DIRECT SUPERVISION AND THAT I AM A DULY LICENSED PROFESSIONAL ENGINEER UNDER THE LAWS OF THE STATE OF MINNESOTA.

PRINT NAME: ANDREW WITTER

SIGNATURE: *[Signature]*

DATE: 2/15/2013 LICENSE NO. 42757

DRAWN BY: JF DATE: 2/5/2013

DESIGN BY: JF DATE: 2/5/2013

CHECKED BY: GA DATE: 2/11/2013

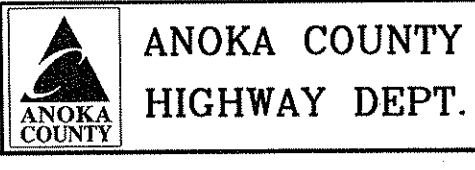

STATE PROJECT NO. \_\_\_\_\_

STATE AID PROJECT NO. \_\_\_\_\_

CITY PROJECT NO. \_\_\_\_\_

COUNTY PROJECT NO. CP 13-16-28

CONSTRUCTION TABS

Sheet 3 of 25 Sheets



S TYPE SP 12.5 WEARING COURSE MIX ( SPWEB440 B )	
STREETS	SQ.YDS.
232ND	218
233RD AVE	187
233RD LN	143
STARK DR	174
	SQ YDS
TOTAL STREET TONS	83
BIT ENTRANCES	
SB N. SCHOOL ENT	76
SB 23122	21
NB 23125	19
SB 23216	24
SB 23224	17
NB 23223	22
SB 23232	24
NB 23231 / 23239	49
SB 23240	25
SB 23250	36
NB 23247	25
NB 23263	29
NB 23267	28
SB 23326	26
SB 23344	25
SB 23356	36
NB 23339	12
SB 23376	41
NB 23347	6
SB 3845	90
NB 23355	20
SB 23390	21
NB 23539	24
NB 23555	30
NB 23611	22
NB 23647	16
NB 23655	23
NB LIFT STA.	29
SB 23671	62
	TOTAL SQ YDS
(SQ YDS X 2" X 115LBS / 2000)	TOTAL DRWAY TONS
	101

T AGGREGATE BEDDING					
STA	LENGTH	WIDTH	DEPTH 8"	CU FT	CU YDS LV
54+20	128	6	0.67	514.56	19
				TOTAL CU YDS	19

U 15" CS PIPE CULVERT			
LOC	STA	DEPTH	QTY
NB	23947		30
NB	23255		30
NB	23263		30
NB	23267		30
NB	233RD LN		8
SB	23326		30
SB	23344		30
SB	23356		30
SB	23376		30
NB	23519		45
NB	23539		55
NB	F.E. 60+00		36
			TOTAL LIN FT
			384

V 24" RC PIPE APRON		
STA	LENGTH	EACH
42+90		2

W 36" RC PIPE APRON		
STA	LENGTH	EACH
54+20		2

X 22" SPAN RC PIPE ARCH CULVERT CL IIA		
LOC	LENGTH	LIN FT
233RD LN		8

Y 22" SPAN RC PIPE ARCH APRON		
LOC	LENGTH	EACH
233RD LN		1

Z 24" RC PIPE CULVERT DES 3006 CL III		
STA	LENGTH	LIN FT
42+90		72

AA 36" RC PIPE CULVERT DES 3006 CL III		
STA	LENGTH	LIN FT
54+20		112

BB 15" GS SAFETY APRON & GRATE DES 3148			
LOC	STA	DEPTH	QTY
NB	23947		2
NB	23255		2
NB	23263		2
NB	23267		2
NB	233RD LN		2
SB	23326		2
SB	23344		2
SB	23356		2
SB	23376		2
NB	23519		2
NB	23539		2
NB	F.E. 60+00		2
			TOTAL
			24

CC ADJUST GATE VALVE & BOX			
STA	LENGTH	QTY	
	14+00	1	
	28+00	1	
	29+00	1	
	31+00	1	
	STARK DR	1	
		TOTAL	5

DD CASTING ASSEMBLY			
LOC	STA	LENGTH	QTY
14RT	14+85		1
14RT	18+40		1
19RT	20+90		1
30RT	26+40		1
30RT	30+40		1
24LT	33+72		1
		TOTAL	6

EE ADJUST FRAME RING AND CASTING			
LOC	STA	LENGTH	QTY
14RT	14+85		1
14RT	18+40		1
19RT	20+90		1
30RT	26+40		1
30RT	30+40		1
24LT	33+72		1
		TOTAL	6

FF RANDOM RIPRAP CLASS II					
PIPE LOC.	STA	LENGTH	WIDTH	DEPTH	CU YDS
SB	16	12		0.67	128.64
NB	16	12		0.67	128.64
FLUMES					
NB	19+00	W10' X L 10"			100
SB	19+00	W10' X L 10"			100
SB	20+70	W10' X L 10"			100
SB	21+20	W10' X L 10"			100
SB	45+70	W10' X L 10"			100
SB	46+20	W10' X L 10"			100
SB	58+20	W10' X L 10"			100
					TOTAL CU YDS
					35

GG GEOTEXTILE FILTER TYPE IV				
PIPE LOC.	STA	LENGTH	WIDTH	DEPTH
SB	16	12		0.67
NB	16	12		0.67
FLUMES				
NB	19+00	W10' X L 10"		100
SB	19+00	W10' X L 10"		100
SB	20+70	W10' X L 10"		100
SB	21+20	W10' X L 10"		100
SB	45+70	W10' X L 10"		100
SB	46+20	W10' X L 10"		100
SB	58+20	W10' X L 10"		100
				TOTAL SQ YDS
				120

HH 6" CONCRETE WALK		
LOC	LENGTH	SQ FT
	28+50	120
	29+00	120
		TOTAL SQ FT
		240

II CONCRETE CURB AND GUTTER DES B418			
LOC	LENGTH	LIN FT	
NB	11+60 - 19+00		750
SB	11+84 - 19+00		716
SB	28+50		47
SB	29+00		47
NB	31+00		30
		TOTAL LIN FT	1590

JJ 6" CONCRETE DRIVEWAY PAVEMENT		
LOC	LENGTH	SQ YDS
NB	23045	16
NB	23339	7
NB	23347	14
NB	23637	30
NB	23647	9
		TOTAL SQ YDS
		76

KK TRUNCATED DOMES		
STA	LENGTH	SQ FT
SB	28+50	12
SB	29+00	12
		TOTAL SQ FT
		24

LL INSTALL MAILBOX SUPPORT				
	ADDRESS		BOX LOC	QTY
NB	23021		RT	1
NB	23037		RT	1
NB	23045		RT	1
NB	23100		RT	1
NB	23102		RT	1
NB	23104		RT	1
NB	23105		RT	1
NB	23112		RT	1
NB	23122		RT	1
NB	23125		RT	1
NB	23215		RT	1
NB	23216		RT	1
NB	23223		RT	1
NB	23231		RT	1
NB	23232		RT	1
NB	23240		RT	1
NB	23247		RT	1
NB	23250		RT	1
NB	23255		RT	1
NB	3815		RT	1
NB	23267		RT	1
NB	23315		RT	1
NB	23326		RT	1
NB	23331		RT	1
NB	23344		RT	1
NB	23339		RT	1
NB	23376		RT	1
NB	23347		RT	1
NB	23355		RT	1
NB	23390		RT	1
NB	23519		RT	1
NB	23539		RT	1
NB	23555		RT	1
NB	23557		RT	1
NB	23601		RT	1
NB	23611		RT	1
NB	23637		RT	1
NB	23647		RT	1
NB	23649		RT	1
NB	23655		RT	1
			TOTAL	40

MM RELOCATE MAILBOX SUPPORT				
	ADDRESS		BOX LOC	QTY
	23021		RT	1
	23037		RT	1
	23045		RT	1
	23100		RT	1
	23102		RT	1
	23104		RT	1
	23105		RT	1
	23112		RT	1
	23122		RT	1
	23125		RT	1
	23231		RT	1
	23232		RT	1
	23240		RT	1
	23250		RT	1
	23247		RT	1
	23255		RT	1
	3815		RT	1
	23267		RT	1
	23315		RT	1
	23326		RT	1
	23519		RT	1
	23539		RT	1
	23539		RT	1
			TOTAL	23

NO	DATE	BY	CHKD	APPR	REVISION

I HEREBY CERTIFY THAT THIS PLAN WAS PREPARED BY ME OR UNDER MY DIRECT SUPERVISION AND THAT I AM A DULY LICENSED PROFESSIONAL ENGINEER UNDER THE LAWS OF THE STATE OF MINNESOTA.

PRINT NAME: ANDREW WITTER

SIGNATURE: *[Signature]*

DATE: 3/7/13 LICENSE NO. 42757

DRAWN BY: JF DATE: 2/5/2013

DESIGN BY: JF DATE: 2/5/2013

CHECKED BY: GA DATE: 2/11/2013

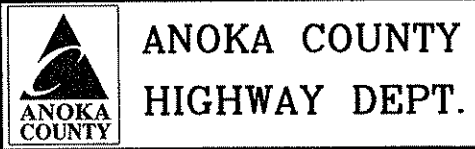

STATE PROJECT NO. \_\_\_\_\_

STATE AID PROJECT NO. \_\_\_\_\_

CITY PROJECT NO. \_\_\_\_\_

COUNTY PROJECT NO. CP 13-16-28

NN BITUMINOUS LINED FLUME					
	LOCATION	WIDTH	LENGTH	SQ FT	SQ YD
NB	19+00	6	12	72.0	8
SB	19+00	6	18	108.0	12
SB	20+70	6	12	72.0	8
SB	21+20	6	12	72.0	8
SB	45+70	6	12	72.0	8
SB	46+20	6	12	72.0	8
SB	58+20	6	12	72.0	8
TOTAL SQ YDS					60

RR EROSION CONTROL BLANKET CAT 00					
	LOC.	LENGTH	WIDTH	SQ YDS	
	11+50 - 19+00	750	16	1333	
	11+86 + 19+00	714	16	1269	
NB	19+00	40	8	36	FLUME
SB	19+00	40	8	36	FLUME
SB	20+70	40	8	36	FLUME
SB	21+20	40	8	36	FLUME
NB	RTL 233RD LN	480	16	853	
SB	RTL 233RD AVE	480	16	853	
NB	PASS STARK DR	620	16	1102	
SB	45+70	40	8	36	FLUME
SB	46+20	40	8	36	FLUME
SB	42+90	40	8	36	X-PIPE
NB	42+90	40	8	36	X-PIPE
SB	54+15	80	8	71	X-PIPE
NB	54+15	80	8	71	X-PIPE
SB	58+20	40	8	36	FLUME
SB	OW SIDE SUPE	620	8	551	
NB	RTL MN 47	480	16	853	
TOTAL SQ YDS				7278	

OO SILT FENCE TYPE MACHINE SLICED			
	LOCATION		LIN FT
NB	11+50 - 19+00		750
SB	11+86 - 19+00		714
NB	19+00		50
SB	19+00		50
SB	20+70		50
SB	21+20		50
NB	233RD LN RTL		480
SB	233RD AVE RTL		480
NB	STARK DR BYPASS		620
NB	MN 47 RTL		480
NB	42+80		50
SB	42+80		50
SB	45+70		50
SB	46+20		50
NB	54+20		100
SB	54+20		100
SB	58+20		50
TOTAL LIN FT			4174

SS RAPID STABILIZATION METHOD 3					
STA	LENGTH	LENGTH X2	WIDTH	SQ FT	SQ YDS
11+50 - 61+40	4990.00	9980.00	6.0	59880.0	6653.3
				ACRE (4840SQ/ACRE)	1.4
				6 MGAL / ACRE	6.0
TOTAL MGAL					8.2

STANDARD DETAIL PLATES	
PLATE NO.	TITLE
3000	REINFORCED CONCRETE PIPE
3014	REINFORCED CONCRETE PIPE ARCH
3022	PRECAST CONCRETE SAFETY APRON
3040	CORRUGATED METAL PIPE CULVERT
3100	CONCRETE APRON FOR REINFORCED CONCRETE PIPE
3110	CONCRETE APRON FOR REINFORCED CONCRETE ARCH PIPE
3128	METAL SAFETY APRON AND GRATE
3133	RIPRAP AT RCP OUTLETS
4026	CONCRETE ENCASED CONCRETE ADJUSTING RINGS
4101	RING CASTING FOR MANHOLE OR CATCH BASIN
8000	STANDARD BARRICADES
8350	MAILBOX SUPPORT ( SWING AWAY TYPE )

TT REMOVABLE PREFORMED PLASTIC MARKING				
STATION	END STATION	LENGTH	DIV. 60' X 2'	X2 LIFTS
11+50	61+40	4990	199.6	399.2
TOTAL LIN FT				399

PP CULVERT END PROTECTION			
	LOCATION		QTY
NB	233RD LN RTL		4
SB	233RD AVE RTL		4
NB	STARK DR BYPASS		2
NB	MN 47 RTL		1
TOTAL			11

QQ SODDING TYPE SALT RESISTANT			
	LOC.		SQ YDS
SB	233RD AVE RTL	16' X 240'	427
TOTAL SQ YDS			427

NO	DATE	BY	CHKD	APPR	REVISION

NAME: P:\13-01-00\CSAH\_28\_(CSAH24-TH47)\Plan\3\_CONSTRUCTION TABS.dwg 02/28/2013 7:26:55 AM

I HEREBY CERTIFY THAT THIS PLAN WAS PREPARED BY ME OR UNDER MY DIRECT SUPERVISION AND THAT I AM A DULY LICENSED PROFESSIONAL ENGINEER UNDER THE LAWS OF THE STATE OF MINNESOTA.

PRINT NAME: ANDREW WITTER

SIGNATURE: *[Signature]*

DATE: 2/1/13 LICENSE NO. 42757

DRAWN BY: JF DATE: 2/5/2013

DESIGN BY: JF DATE: 2/5/2013

CHECKED BY: GA DATE: 2/11/2013

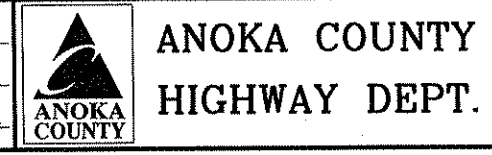

STATE PROJECT NO. \_\_\_\_\_

STATE AID PROJECT NO. \_\_\_\_\_

CITY PROJECT NO. \_\_\_\_\_

COUNTY PROJECT NO. CP 13-16-28

CONSTRUCTION TABS

Sheet 5 of 25 Sheets

ITEMS INCLUDED IN RTL / BYPASS BY THE EACH ARE - COMMON EXCAVATION, GRANULAR BORROW, TOPSOIL BORROW AND AGG BASE CLASS 5. OTHER ITEMS ARE LISTED FOR INFORMATIONAL PURPOSES AND ARE INCLUDED IN THE MAIN SEQ.

STREET	DIR.	RTL / BYPASS	WIDTH	LENGTH	REMOVE PIPE CULVERTS 2104.501 (LIN FT)	COMMON EXCAVATION 2105.501 (CU YD)	GRANULAR BORROW (CV) 2105.521 (CU YD)	TOPSOIL BORROW (LV) 2105.525 (CU YD)	AGG BASE CLASS 5 (CV) 2211.501 (TON)	15" CS PIPE CULVERT 2501.511 (LIN FT)	22" SPAN RC PIPE-ARCH CULV CL IIA 2501.521 (LIN FT)	22" SPAN RC PIPE ARCH APRON 2501.525 (EACH)	15" GS SAFETY APRON & GRATE DES 3148 2501.567 (EACH)	ADJUST GATEVALVE AND BOX 2504.602 EACH	CASTING ASSEMBLY 2506.516 (EACH)	ADJUST FRAME AND CASTING 2506.522 (EACH)	SILT FENCE MACHINE SLICED 2573.502 (LIN FT)	CULVERT PROTECTION 2573.602 (EACH)	SODDING TYPE SALT RESISTANT 2575.505 (SQ YD)	EROSION CONTROL BLANKET CAT 00 2575.523 (SQ YD)
233RD LN	NB	RTL	12	480.0		155	262	94	230	120	8	1	8	2	1	1	480	4	0	853
COST/UNIT					\$8.00	\$4.05	\$10.62	\$18.36	\$10.43	\$25.00	\$97.00	\$441.00	\$502.00	\$285.00	\$550.00	\$415.00	\$1.80	\$150.00	\$7.00	\$2.00
TOTAL					\$896.00	\$627.75	\$2,782.44	\$1,723.27	\$2,398.90	\$3,000.00	\$776.00	\$441.00	\$4,016.00	\$570.00	\$550.00	\$415.00	\$864.00	\$600.00	\$0.00	\$1,706.00
233RD AVE	SB	RTL	12	480.0	98	290	435	94	230	120	0	0	8	1	2	2	480	4	426	853
COST/UNIT					\$8.00	\$4.05	\$10.62	\$18.36	\$10.43	\$25.00	\$97.00	\$441.00	\$502.00	\$285.00	\$550.00	\$415.00	\$1.80	\$150.00	\$7.00	\$2.00
TOTAL					\$784.00	\$1,174.50	\$4,619.70	\$1,725.84	\$2,398.90	\$3,000.00	\$0.00	\$0.00	\$4,016.00	\$285.00	\$1,100.00	\$830.00	\$864.00	\$600.00	\$2,982.00	\$1,706.00
STARK DR	NB	BYPASS	12	620.0	95	375	562	121	298	100	0	0	4	0	0	0	620	2	0	1102
COST/UNIT					\$8.00	\$4.05	\$10.62	\$18.36	\$10.43	\$25.00	\$97.00	\$441.00	\$502.00	\$285.00	\$550.00	\$415.00	\$1.80	\$150.00	\$7.00	\$2.00
TOTAL					\$760.00	\$1,518.75	\$5,968.44	\$2,221.56	\$3,108.14	\$2,500.00	\$0.00	\$0.00	\$2,008.00	\$0.00	\$0.00	\$0.00	\$1,116.00	\$300.00	\$0.00	\$2,204.00
MN 47	NB	RTL	12	480.0	30	290	435	94	230	36	0	0	2	0	0	0	480	1	0	853

NEW GR - GR GRADES

EX CL PROFILE	NEW CL PROFILE	STA	LEFT	%	DIST	CL GR	DIST	%	RIGHT	STA
914.21	914.07	19+00	912.75	0.025	19.62	913.24	27.12	0.025	912.56	19+00
	914.18	18+75	912.86	0.025	19.62	913.35	25.45	0.025	912.71	18+75
	914.30	18+50	912.98	0.025	19.62	913.47	23.80	0.025	912.87	18+50
	914.43	18+25	913.11	0.025	19.62	913.60	22.14	0.025	913.05	18+25
914.75	914.57	18+00	913.25	0.025	19.62	913.74	20.48	0.025	913.23	18+00
	914.65	17+87	913.32	0.025	19.62	913.81	19.62	0.025	913.32	17+87
	914.72	17+75	913.40	0.025	19.62	913.89	19.62	0.025	913.40	17+75
	914.88	17+70	913.56	0.025	19.62	914.05	19.62	0.025	913.56	17+70
	915.04	17+50	913.73	0.025	19.62	914.22	19.62	0.025	913.73	17+50
	915.23	17+25	913.91	0.025	19.62	914.40	19.62	0.025	913.91	17+25
915.90	915.42	17+00	914.10	0.025	19.62	914.59	19.62	0.025	914.10	17+00
	915.62	16+75	914.30	0.025	19.62	914.79	19.62	0.025	914.30	16+75
	915.82	16+50	914.50	0.025	19.62	914.99	19.62	0.025	914.50	16+50
	916.02	16+25	914.70	0.025	19.62	915.19	19.62	0.025	914.70	16+25
916.70	916.22	16+00	914.90	0.025	19.62	915.39	19.62	0.025	914.90	16+00
	916.42	15+75	915.10	0.025	19.62	915.59	19.62	0.025	915.10	15+75
	916.62	15+50	915.30	0.025	19.62	915.79	19.62	0.025	915.30	15+50
	916.82	15+25	915.50	0.025	19.62	915.99	19.62	0.025	915.50	15+25
917.50	917.02	15+00	915.70	0.025	19.62	916.19	19.62	0.025	915.70	15+00
	917.22	14+75	915.90	0.025	19.62	916.39	19.62	0.025	915.90	14+75
	917.42	14+50	916.10	0.025	19.62	916.59	19.62	0.025	916.10	14+50
	917.62	14+25	916.30	0.025	19.62	916.79	19.62	0.025	916.30	14+25
918.26	917.82	14+00	916.50	0.025	19.62	916.99	19.62	0.025	916.50	14+00
	918.02	13+75	916.70	0.025	19.62	917.19	19.62	0.025	916.70	13+75
	918.22	13+50	916.90	0.025	19.62	917.39	19.62	0.025	916.90	13+50
	918.42	13+25	917.10	0.025	19.62	917.59	19.62	0.025	917.10	13+25
919.10	918.62	13+00	917.30	0.025	19.62	917.79	19.62	0.025	917.30	13+00
	918.82	12+75	917.50	0.025	19.62	917.99	19.62	0.025	917.50	12+75
	919.02	12+50	917.70	0.025	19.62	918.19	19.62	0.025	917.70	12+50
	919.22	12+25	917.90	0.025	19.62	918.39	19.62	0.025	917.90	12+25
919.60	919.42	12+00	918.10	0.025	19.62	918.59	19.62	0.025	918.10	12+00
	919.62	11+75	918.30	0.025	19.62	918.79	19.62	0.025	918.30	11+75
919.82	919.62	11+50	918.50	0.025	19.62	918.99	19.62	0.025	918.50	11+50

NEW CLASS-5 GRADES

EX CL PROFILE	NEW CL PROFILE	STA	LEFT	%	DIST	CL CLASS-5	DIST	%	RIGHT	STA
914.21	914.07	19+00	913.25	0.025	19.62	913.74	27.12	0.025	913.06	19+00
	914.18	18+75	913.36	0.025	19.62	913.85	25.46	0.025	913.21	18+75
	914.30	18+50	913.48	0.025	19.62	913.97	23.80	0.025	913.37	18+50
	914.43	18+25	913.61	0.025	19.62	914.1	22.14	0.025	913.55	18+25
914.75	914.57	18+00	913.75	0.025	19.62	914.24	20.48	0.025	913.73	18+00
	914.65	17+87	913.82	0.025	19.62	914.31	19.62	0.025	913.82	17+87
	914.72	17+75	913.90	0.025	19.62	914.39	19.62	0.025	913.90	17+75
	914.88	17+70	914.06	0.025	19.62	914.55	19.62	0.025	914.06	17+70
	915.06	17+50	914.23	0.025	19.62	914.72	19.62	0.025	914.23	17+50
	915.23	17+25	914.41	0.025	19.62	914.9	19.62	0.025	914.41	17+25
915.90	915.42	17+00	914.60	0.025	19.62	915.09	19.62	0.025	914.60	17+00
	915.62	16+75	914.80	0.025	19.62	915.29	19.62	0.025	914.80	16+75
	915.82	16+50	915.00	0.025	19.62	915.49	19.62	0.025	915.00	16+50
	916.02	16+25	915.20	0.025	19.62	915.69	19.62	0.025	915.20	16+25
916.70	916.22	16+00	915.40	0.025	19.62	915.89	19.62	0.025	915.40	16+00
	916.42	15+75	915.60	0.025	19.62	916.09	19.62	0.025	915.60	15+75
	916.62	15+50	915.80	0.025	19.62	916.29	19.62	0.025	915.80	15+50
	916.82	15+25	916.00	0.025	19.62	916.49	19.62	0.025	916.00	15+25
917.50	917.02	15+00	916.20	0.025	19.62	916.69	19.62	0.025	916.20	15+00
	917.22	14+75	916.40	0.025	19.62	916.89	19.62	0.025	916.40	14+75
	917.42	14+50	916.60	0.025	19.62	917.09	19.62	0.025	916.60	14+50
	917.62	14+25	916.80	0.025	19.62	917.29	19.62	0.025	916.80	14+25
918.26	917.82	14+00	917.00	0.025	19.62	917.49	19.62	0.025	917.00	14+00
	918.02	13+75	917.20	0.025	19.62	917.69	19.62	0.025	917.20	13+75
	918.22	13+50	917.40	0.025	19.62	917.89	19.62	0.025	917.40	13+50
	918.42	13+25	917.60	0.025	19.62	918.09	19.62	0.025	917.60	13+25
919.10	918.62	13+00	917.80	0.025	19.62	918.29	19.62	0.025	917.80	13+00
	918.82	12+75	918.00	0.025	19.62	918.49	19.62	0.025	918.00	12+75
	919.02	12+50	918.20	0.025	19.62	918.69	19.62	0.025	918.20	12+50
	919.22	12+25	918.40	0.025	19.62	918.89	19.62	0.025	918.40	12+25
919.60	919.42	12+00	918.60	0.025	19.62	919.09	19.62	0.025	918.60	12+00
	919.62	11+75	918.80	0.025	19.62	919.29	19.62	0.025	918.80	11+75
919.82	919.62	11+50	919.00	0.025	19.62	919.49	19.62	0.025	919.00	11+50

NEW TBC CURB GRADES

EX CL PROFILE	STA	HUB	TBC	C/F	GUTTER	LP	%	DIST	FINISHED CL PROFILE	DIST	%	LP	GUTTER	HUB	TBC	C/F	STA
914.21	19+00		913.90		913.57	913.66	0.025	16.5	914.07	24.0	0.025	913.47	913.38		913.71		19+00
	18+75		914.01		913.68	913.77	0.025	16.5	914.16	23.1	0.025	913.60	913.51		913.84		18+75
	18+50		914.13		913.80	913.89	0.025	16.5	914.30	21.5	0.025	913.76	913.67		914.00		18+50
	18+25		914.26		913.93	914.02	0.025	16.5	914.43	19.8	0.025	913.93	913.84		914.17		18+25
914.75	18+00		914.40														

AVR. 2' DEPTH CALC.  
LSB RIGHT TURN LANE @ 233RD AVE

NEW 12' RTL.

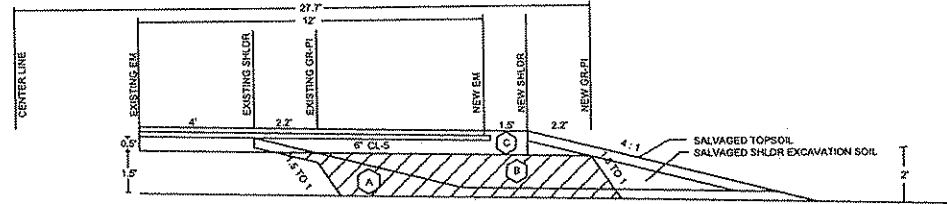

- (A) COMMON EXCAVATION  
8.71 SQ FT
- (B) GRANULAR BORROW  
(HATCHED AREA)  
14.74 SQ FT
- (C) CLASS 5  
7.20 SQ FT

CU YDS PER 100'

(A) COMMON EXCAVATION  
 $8.71 \text{ SQ FT} \times 100' = 871 \text{ CU FT} / 27 = 32.25 \text{ CU YDS (CV)}$

(B) GRANULAR BORROW  
 $14.74 \text{ SQ FT} \times 100' = 1474 \text{ CU FT} / 27 = 54.59 \text{ CU YDS (CV)}$

(C) BASE CLASS 5  
 $7.20 \text{ SQ FT} \times 100' = 720 \text{ CU FT} / 27 = 26.66 \text{ CU YDS}$

SUMMARY  
480' RTL.

(A) COMMON EXCAVATION  
 $32.25 \text{ CU YDS (PER 100')} \times 4.80 \text{ RTL.} = 154.80 \text{ CU YDS (CV)}$

(B) GRANULAR BORROW  
 $54.59 \text{ CU YDS (PER 100')} \times 4.80 \text{ RTL.} = 262.03 \text{ CU YDS (CV)}$

(C) BASE CLASS 5  
 $26.66 \text{ CU YDS (PER 100')} \times 4.80 \text{ BYPASS} = 127.96 \text{ CU YDS} \times 1.8 = 230.34 \text{ TONS (CV)}$

RTL / BYPASS LAYOUT

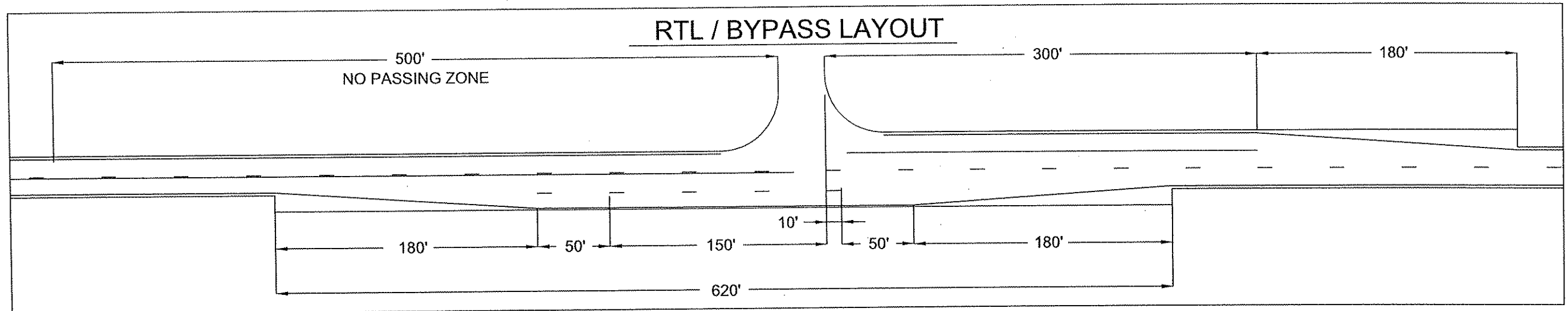

NO	DATE	BY	CHKD	APPR	REVISION

NAME: P:\13-01-00\CSAH\_28\_CSAH24-TH47\Plan\5 RTL BYPASS DETAILS.dgn 02/28/2013 7:36:54 AM

I HEREBY CERTIFY THAT THIS PLAN WAS PREPARED BY ME OR UNDER MY DIRECT SUPERVISION AND THAT I AM A DULY LICENSED PROFESSIONAL ENGINEER UNDER THE LAWS OF THE STATE OF MINNESOTA.  
PRINT NAME: ANDREW WITTER  
SIGNATURE: *[Signature]*  
DATE: 3/1/13 LICENSE NO. 42757

DRAWN BY: JF DATE: 2/5/2013  
DESIGN BY: JF DATE: 2/9/2013  
CHECKED BY: GA DATE: 2/11/2013

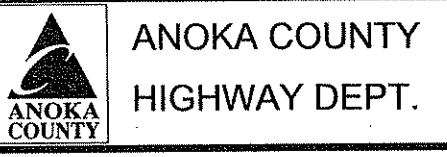

STATE PROJECT NO. \_\_\_\_\_  
STATE AID PROJECT NO. \_\_\_\_\_  
CITY PROJECT NO. \_\_\_\_\_  
COUNTY PROJECT NO. CP 13-16-28





GRAVEL ENTRANCES AND FEILD ENTRANCES

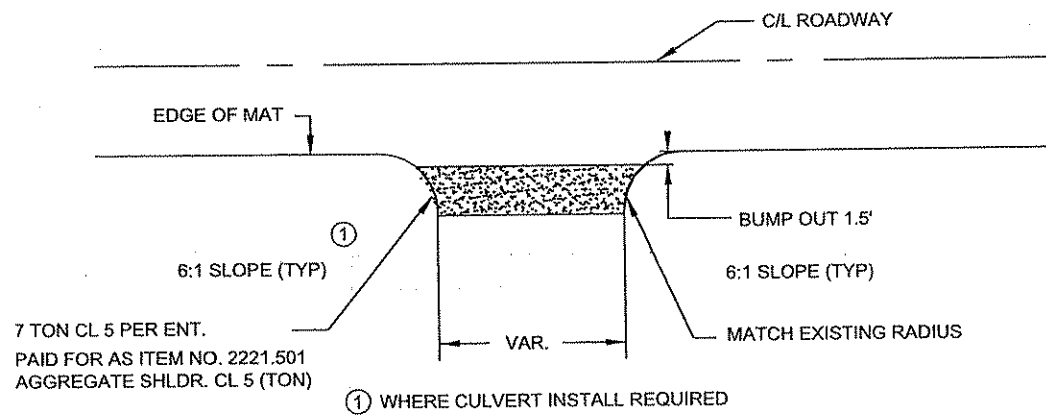

PAVED ENTRANCES

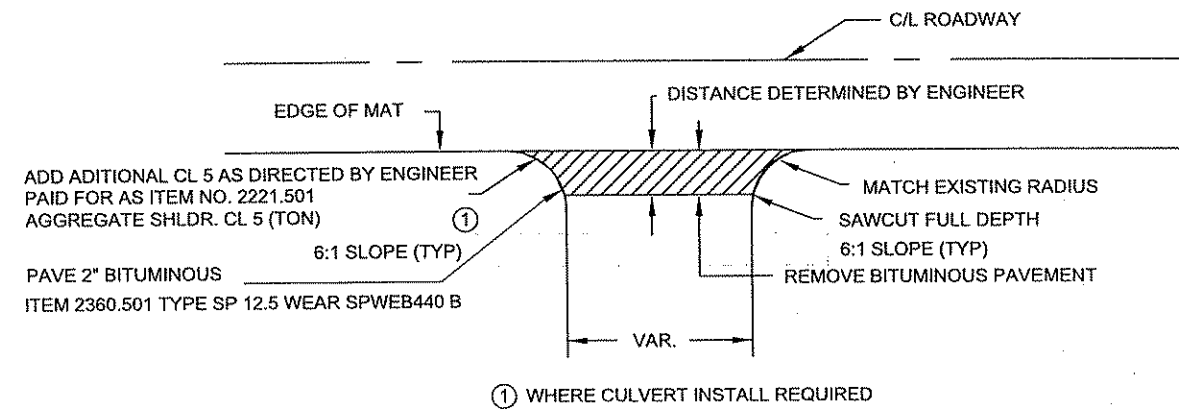

CONCRETE ENTRANCES

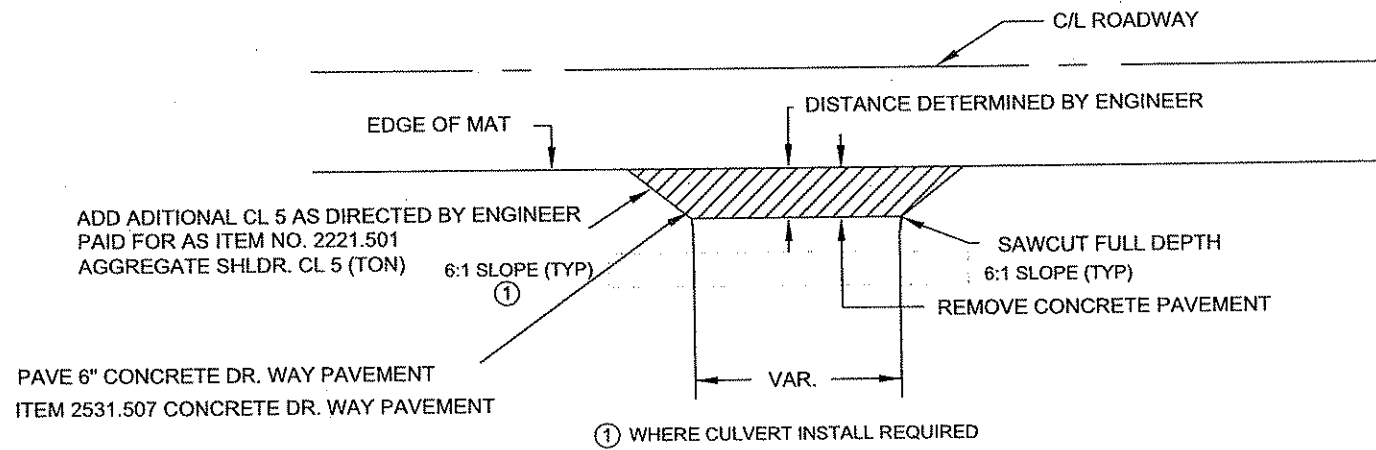

PAVED STREET APPROACHES

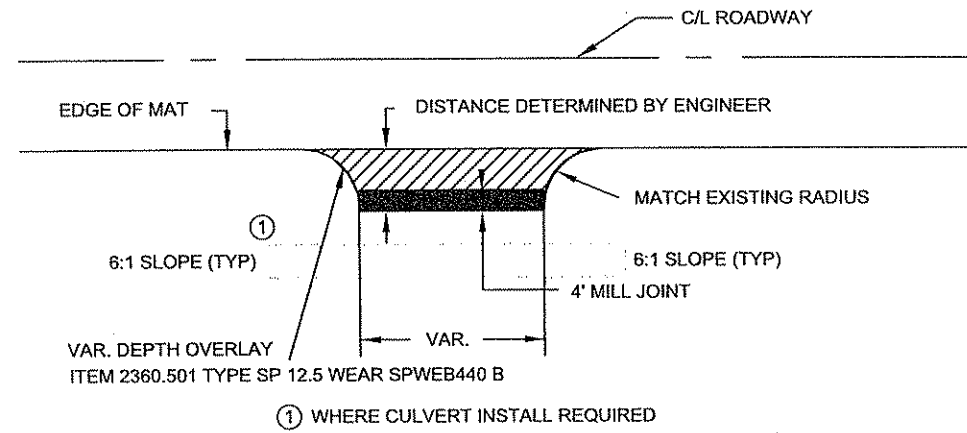

ALL ENTRANCES BEHIND NEW CURB 11+50 - 19+00

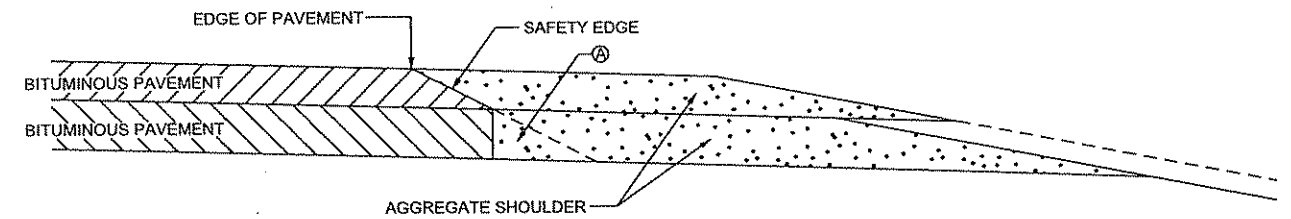
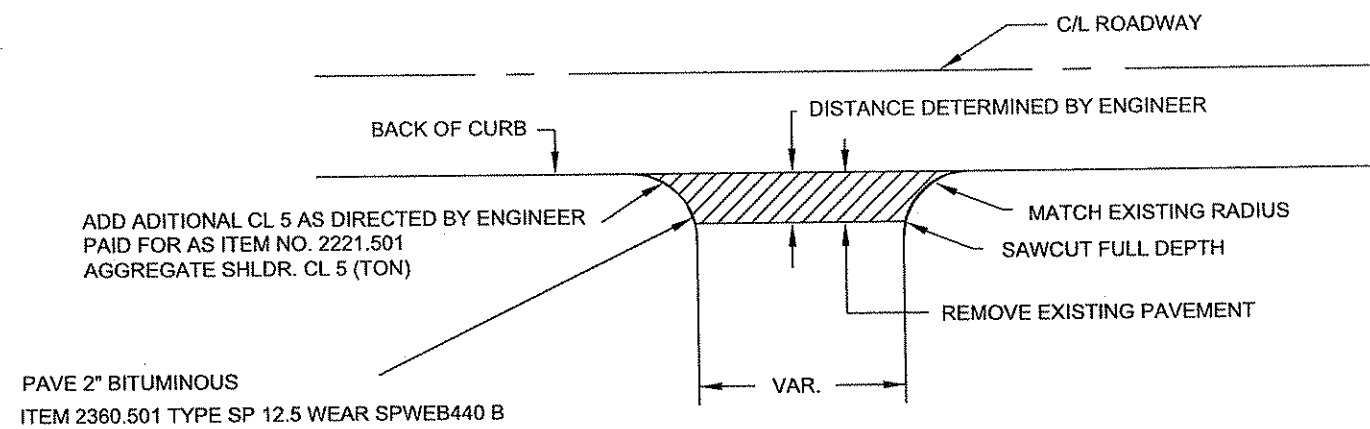

FIGURE B  
BITUMINOUS PAVEMENT  
SAFETY EDGE TO BE USED IN ALL NON-CURB AREAS ON SHOULDER.  
Ⓐ OPTIONAL DESIGN EXTENDS SAFETY EDGE DEEPER  
THAN 6" AND WIDER THAN 10.5". SEE SPECIAL PROVISIONS.

NO	DATE	BY	CKD	APPR	REVISION

NAME: P:\13-01-00\CSAH\_26\_(CSAH24-TH47)\Plan6\_CONST.DETAILED.dgn 02/28/2013 7:40:09 AM

I HEREBY CERTIFY THAT THIS PLAN WAS PREPARED BY ME OR UNDER MY DIRECT SUPERVISION AND THAT I AM A DULY LICENSED PROFESSIONAL ENGINEER UNDER THE LAWS OF THE STATE OF MINNESOTA.

PRINT NAME: ANDREW WITTER

SIGNATURE: *Andrew Witter*

DATE: 2/13/13 LICENSE NO. 42757

DRAWN BY: JF DATE: 2/5/2013

DESIGN BY: JF DATE: 2/5/2013

CHECKED BY: GA DATE: 2/11/2013



ANOKA COUNTY  
HIGHWAY DEPT.

STATE PROJECT NO. \_\_\_\_\_

STATE AID PROJECT NO. \_\_\_\_\_

CITY PROJECT NO. \_\_\_\_\_

COUNTY PROJECT NO. CP 13-16-28

CONSTRUCTION DETAILS

Sheet 9 of 25 Sheets

PAVED ENTRANCES

DETAILS

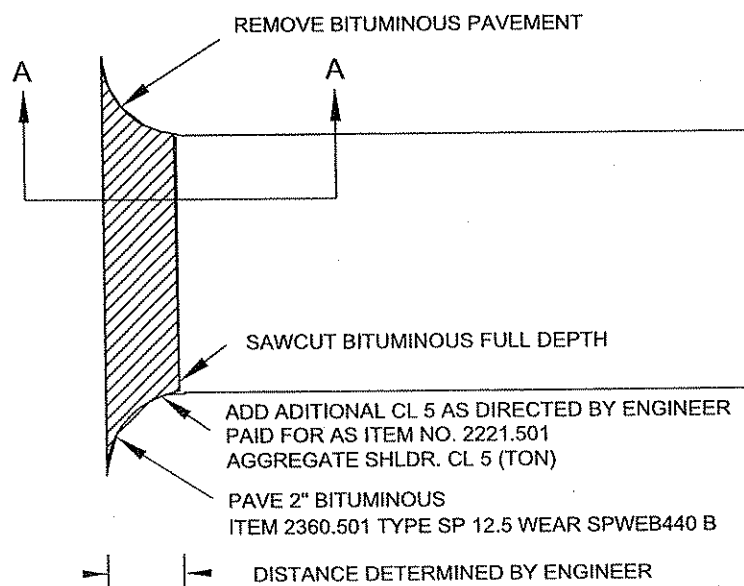

PAVED ENTRANCE DETAILS A - A

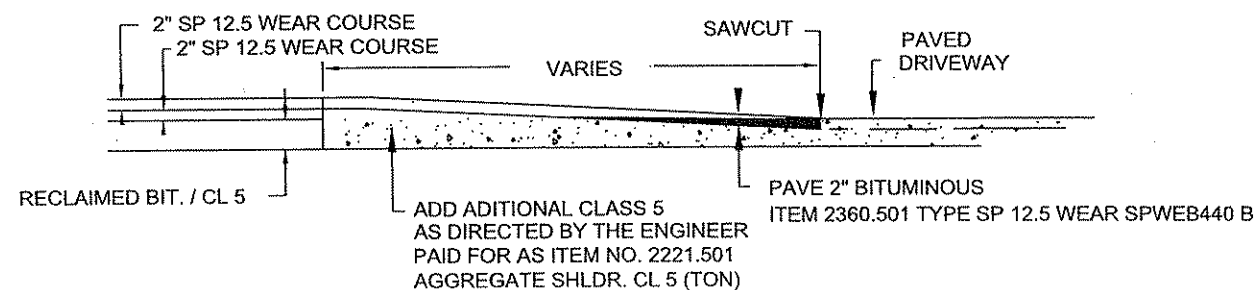

PAVED STREET APPROACH

JOINT DETAILS

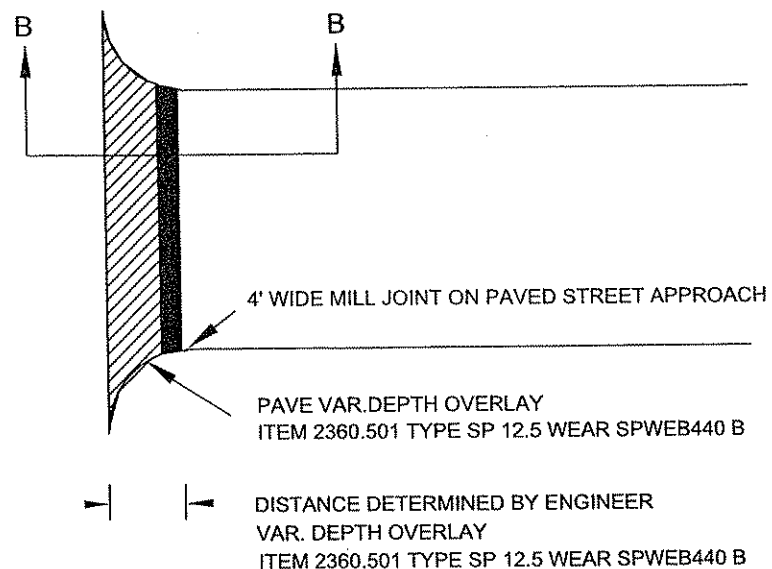

PAVED STREET APPROACH JOINT DETAILS B - B

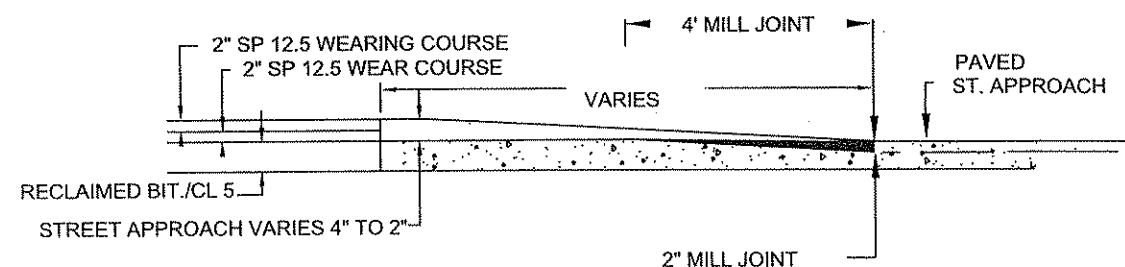

NO.	DATE	BY	CKD	APPR	REVISION

NAME: P:\113-01-00\CSAH\_28\_(CSAH24-TH47)\Plan\6\_CONST.DETAILS.dgn 02/28/2013 7:40:29 AM

I HEREBY CERTIFY THAT THIS PLAN WAS PREPARED BY ME OR UNDER MY DIRECT SUPERVISION AND THAT I AM A DULY LICENSED PROFESSIONAL ENGINEER UNDER THE LAWS OF THE STATE OF MINNESOTA.

PRINT NAME: ANDREW BITTNER  
 SIGNATURE: *[Signature]*  
 DATE: 3/7/13 LICENSE NO. 42757

DRAWN BY: JF DATE: 2/5/2013  
 DESIGN BY: JF DATE: 2/5/2013  
 CHECKED BY: GA DATE: 2/11/2013

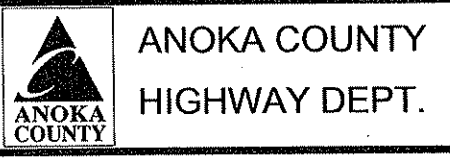

STATE PROJECT NO. \_\_\_\_\_  
 STATE AID PROJECT NO. \_\_\_\_\_  
 CITY PROJECT NO. \_\_\_\_\_  
 COUNTY PROJECT NO. CP 13-16-28

CONSTRUCTION DETAILS  
 Sheet 10 of 25 Sheets

# EXISTING TYPICALS

STA 11+50 - 17+70

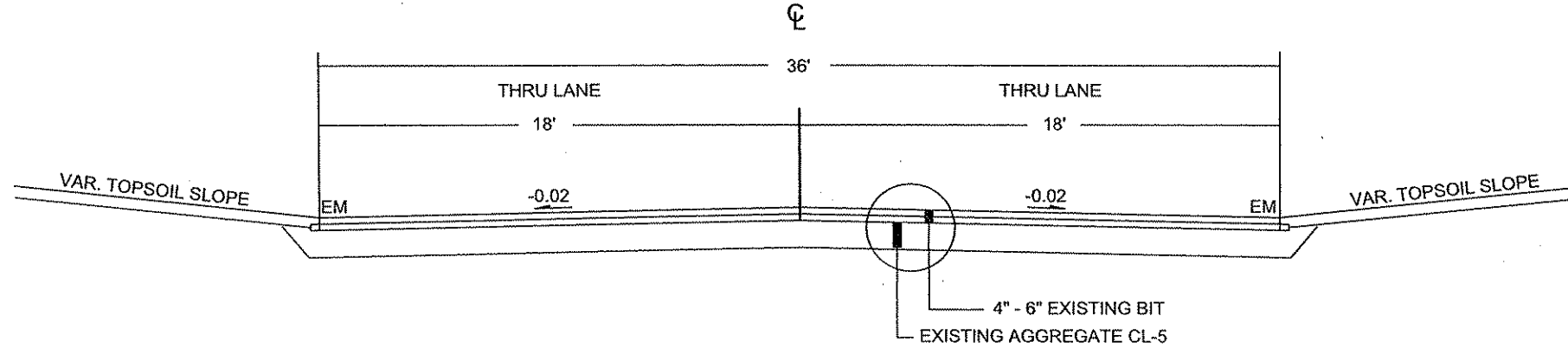

STA 17+70 - 23+90 (EXISTING BYPASS AND RTL FOR 232ND)  
 STA 43+00 - 48+20 (EXISTING RTL FOR STARK DR)

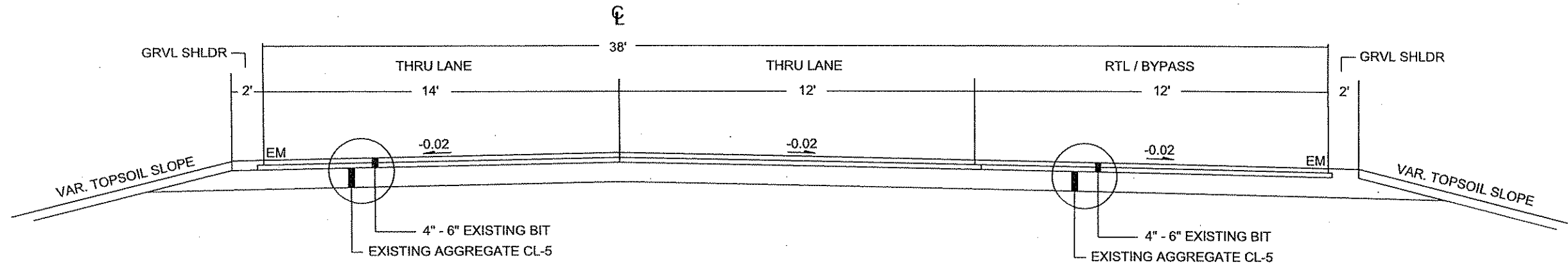

STA 23+90 - 43+00  
 STA 48+20 - 61+40

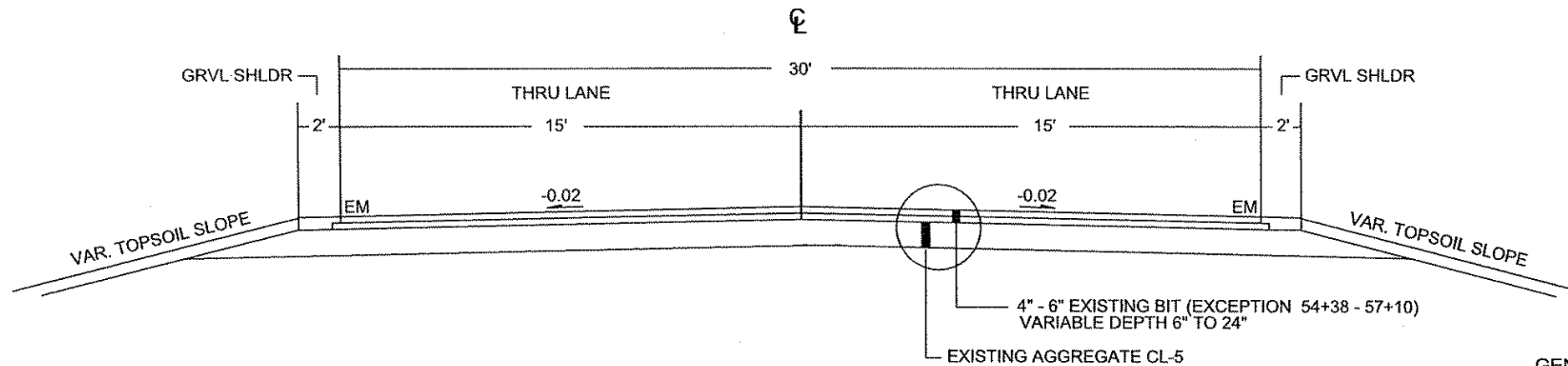

**GENERAL NOTES:**

- ALL CROSS SLOPES ARE APPROXIMATE
- UNLESS OTHERWISE SPECIFIED, THE CLASS 5 CROSS SLOPES SHALL BE THE SAME AS THE FINISHED SURFACE OF THE MAINLINE.

NO	DATE	BY	CKD	APPR	REVISION

NAME: P:\113-01-09\CSAH\_28\_(CSAH24-TH47)\Plan7\_TYPICALS.dgn 02/28/2013 7:44:30 AM

I HEREBY CERTIFY THAT THIS PLAN WAS PREPARED BY ME OR UNDER MY DIRECT SUPERVISION AND THAT I AM A DULY LICENSED PROFESSIONAL ENGINEER UNDER THE LAWS OF THE STATE OF MINNESOTA.  
 PRINT NAME: ANDREW WITTER  
 SIGNATURE: *[Signature]*  
 DATE: 3/13/13 LICENSE NO. 42757

DRAWN BY JF DATE 2/5/2013  
 DESIGN BY JF DATE 2/5/2013  
 CHECKED BY GA DATE 2/11/2013

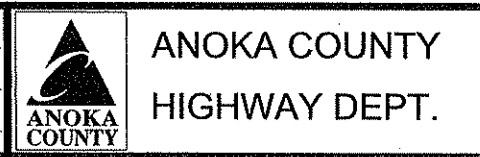

STATE PROJECT NO. \_\_\_\_\_  
 STATE AID PROJECT NO. \_\_\_\_\_  
 CITY PROJECT NO. \_\_\_\_\_  
 COUNTY PROJECT NO. CP 13-16-28

TYPICALS  
 Sheet 11 of 25 Sheets



# PROPOSED TYPICALS

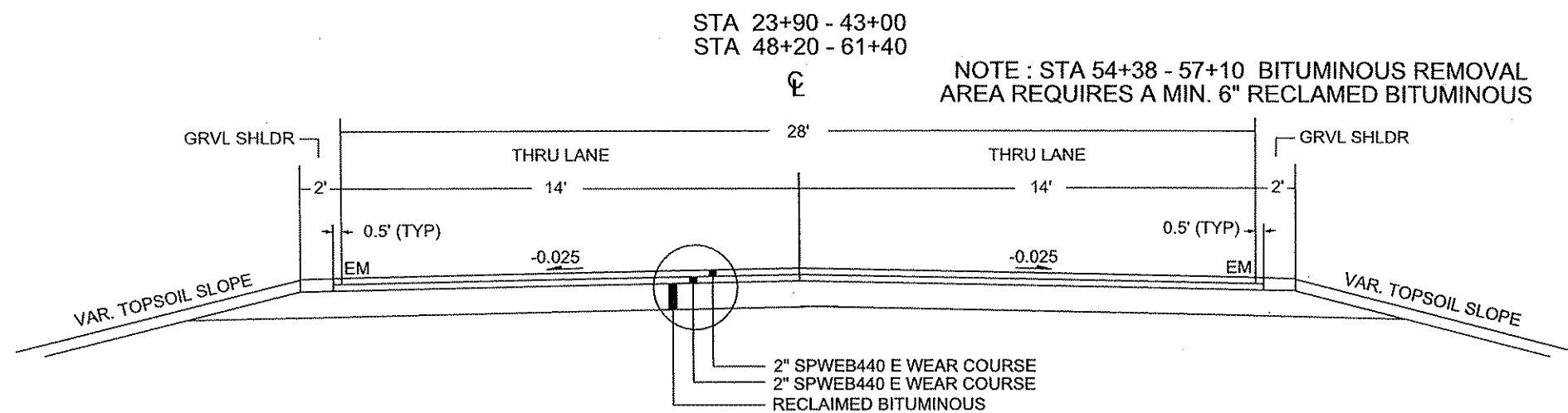
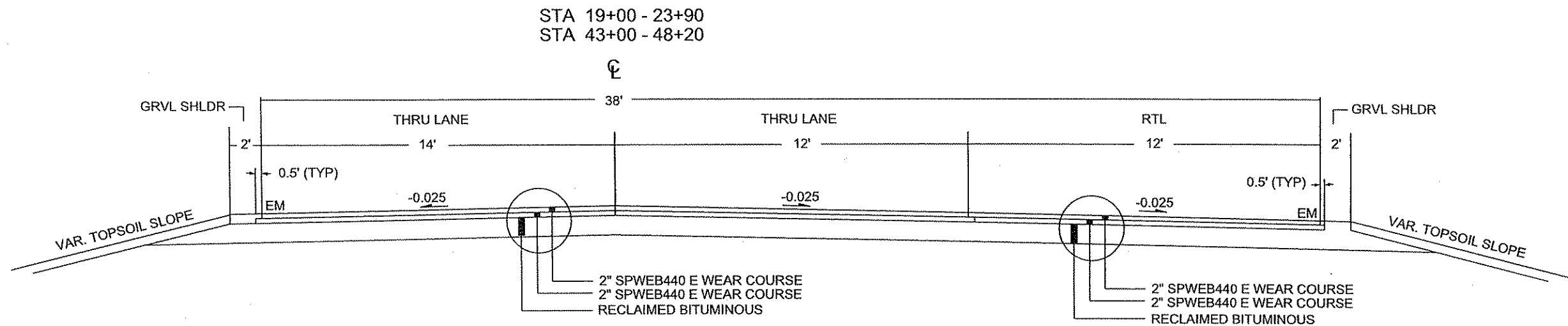
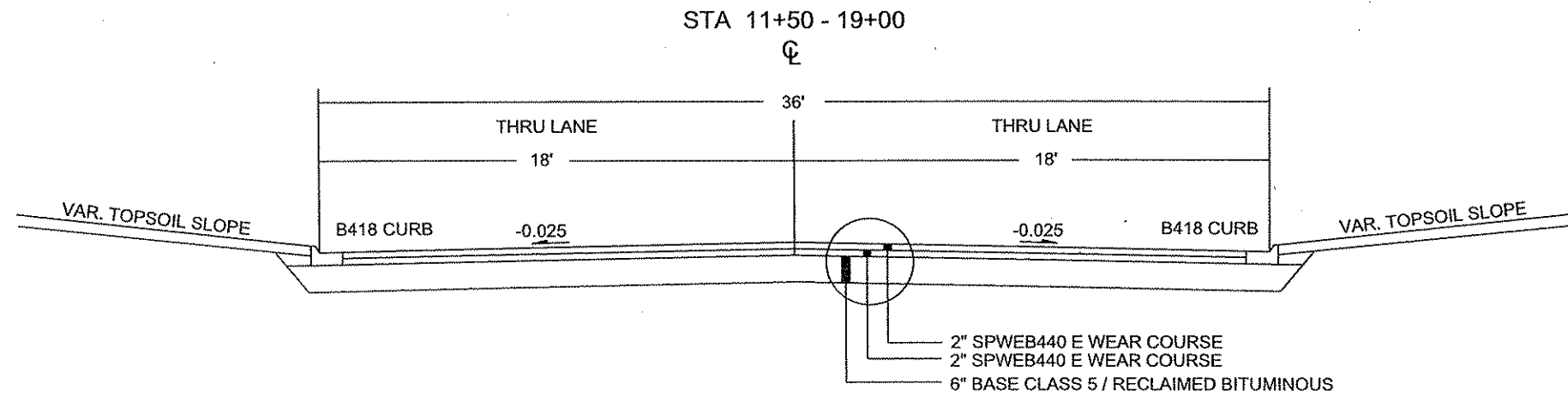

NOTE : STA 54+38 - 57+10 BITUMINOUS REMOVAL AREA REQUIRES A MIN. 6" RECLAIMED BITUMINOUS

GENERAL NOTES:

- ALL CROSS SLOPES ARE APPROXIMATE
- UNLESS OTHERWISE SPECIFIED, THE CLASS 5 CROSS SLOPES SHALL BE THE SAME AS THE FINISHED SURFACE OF THE MAINLINE.

NO	DATE	BY	CKD	APPR	REVISION
NAME: P:\13-01-00\CSAH_28_CSAH24-TH47\Plan7_TYPICALS.dgn					
02/28/2013 7:44:56 AM					

I HEREBY CERTIFY THAT THIS PLAN WAS PREPARED BY ME OR UNDER MY DIRECT SUPERVISION AND THAT I AM A DULY LICENSED PROFESSIONAL ENGINEER UNDER THE LAWS OF THE STATE OF MINNESOTA.

PRINT NAME: ANDREW WINTER

SIGNATURE: *Andrew Winter*

DATE: 3/1/13 LICENSE NO. 42757

DRAWN BY JF DATE 2/5/2013

DESIGN BY JF DATE 2/5/2013

CHECKED BY GA DATE 2/11/2013



ANOKA COUNTY  
HIGHWAY DEPT.

STATE PROJECT NO. \_\_\_\_\_

STATE AID PROJECT NO. \_\_\_\_\_

CITY PROJECT NO. \_\_\_\_\_

COUNTY PROJECT NO. CP 13-16-28

TYPICALS

Sheet 12 of 25 Sheets

# CORES CSAH 28

CORE #1 LNB APPROX 1/2 MILE NORTH OF BRIDGE ST , BIT 4-3/4 " , BIT SAND + 1/2" , NO BASE.

CORE #2 LSB IN CURVE AREA NORTH OF X-PIPE, BIT 23-1/2" , +BIT SAND, NO BASE.

CORE #3 LSB IN CURVE AREA APPROX 200' NORTH OF X-PIPE, BIT 4-5/8" , 1-3/8" BROKEN BIT, +BIT SAND, NO BASE.

CORE #4 LSB IN CURVE AREA APPROX 50' SOUTH OF X-PIPE, BIT 6" , + BIT SAND, NO BASE.

CORE #5 LSB SHOULDER SOUTH OF 233<sup>RD</sup> AVE, BIT 1 3/4" , +BIT SAND , NO BASE.

CORE #6 LSB SOUTH OF 232<sup>ND</sup> , BIT 5 1/8" , + BIT SAND, NO BASE.

HOLES WERE PATCHED , CORES ARE RETAINED IN COUNTY LAB.

CORE INFO FOR INFORMATIONAL PURPOSES ONLY  
CONTRACTOR TO FIELD VERIFY.

```

Beginning chain ALI28 description
=====
Point 200      N  228,188.8852 E  475,354.8855 Sta  10+00.00
Course from 200 to 201 N 0° 33' 25.39" W Dist 1,871.2283
Point 201      N  230,060.0250 E  475,336.6930 Sta  28+71.23
Course from 201 to PC ALI28-1 N 0° 38' 29.65" W Dist 473.9011

Curve Data
-----*
Curve ALI28-1
P.I. Station  34+87.16 N  230,675.9042 E  475,329.0357
Delta = 13° 55' 04.87" (LT)
Degree = 4° 55' 26.42"
Tangent = 142.0273
Length = 282.6565
Radius = 1,163.6011
External = 8.6358
Long Chord = 281.9620
Mid. Ord. = 8.5722
P.C. Station  33+45.13 N  230,533.8963 E  475,331.3866
P.T. Station  36+27.79 N  230,813.1774 E  475,292.5963
C.C.          N  230,514.6363 E  474,167.9449
Back = N 0° 56' 54.27" W
Ahead = N 14° 51' 59.13" W
Chord Bear = N 7° 54' 26.70" W

Course from PT ALI28-1 to PCAU28-2 N 14° 01' 47.99" W Dist 1,194.1423

Curve Data
-----*
Curve ALI28-2
P.I. Station  49+78.25 N  232,123.3591 E  474,965.2026
Delta = 18° 27' 18.04" (LT)
Degree = 5° 57' 15.58"
Tangent = 156.3253
Length = 309.9428
Radius = 962.2544
External = 12.6154
Long Chord = 308.6047
Mid. Ord. = 12.4522
P.C. Station  48+21.93 N  231,971.6972 E  475,903.1006
P.T. Station  51+31.87 N  232,255.2245 E  474,881.2436
C.C.          N  231,738.4180 E  474,069.5513
Back = N 14° 01' 47.99" W
Ahead = N 32° 29' 06.03" W
Chord Bear = N 23° 15' 27.01" W

Course from PT ALI28-2 to PCAU28-3 N 31° 38' 57.95" W Dist 4.0199

Curve Data
-----*
Curve ALI28-3
P.I. Station  53+65.10 N  232,453.5873 E  474,758.5732
Delta = 28° 38' 10.45" (LT)
Degree = 6° 22' 48.40"
Tangent = 229.2092
Length = 448.8359
Radius = 898.0371
External = 28.7895
Long Chord = 444.1789
Mid. Ord. = 27.8952
P.C. Station  51+35.89 N  232,258.6465 E  474,879.1343
P.T. Station  55+84.73 N  232,566.9044 E  474,559.3344
C.C.          N  231,786.2908 E  474,115.3603
Back = N 31° 44' 04.93" W
Ahead = N 60° 22' 15.37" W
Chord Bear = N 46° 03' 10.15" W

Course from PT ALI28-3 to PCAU28-4 N 60° 55' 48.81" W Dist 7.2000

Curve Data
-----*
Curve ALI28-4
P.I. Station  58+11.68 N  232,677.1452 E  474,360.9585
Delta = 24° 47' 05.24" (LT)
Degree = 5° 43' 44.20"
Tangent = 219.7494
Length = 432.6240
Radius = 1,000.1105
External = 23.8577
Long Chord = 429.2588
Mid. Ord. = 23.3018
P.C. Station  55+91.93 N  232,570.4028 E  474,553.0414
P.T. Station  60+24.55 N  232,693.5323 E  474,141.8210
C.C.          N  231,696.2064 E  474,067.2412
Back = N 60° 56' 18.99" W
Ahead = N 85° 43' 24.23" W
Chord Bear = N 73° 19' 51.61" W

Course from PT ALI28-4 to 202 N 87° 26' 23.20" W Dist 146.1066

Point 202      N  232,700.0588 E  473,995.8603 Sta  61+70.66
=====
Ending chain ALI28 description
    
```

NO	DATE	BY	CHKD	APPR	REVISION
NAME: P:\13-01-00\CSAH_28_(CSAH24-T147)\Plan\8 ALIGNMENT.dgn					

I HEREBY CERTIFY THAT THIS PLAN WAS PREPARED BY ME OR UNDER MY DIRECT SUPERVISION AND THAT I AM A DULY LICENSED PROFESSIONAL ENGINEER UNDER THE LAWS OF THE STATE OF MINNESOTA.

PRINT NAME: ANDREW WATNER

SIGNATURE: *[Signature]*

DATE: 3/7/13

LICENSE NO. 42757

DRAWN BY JF DATE 2/5/2013

DESIGN BY JF DATE 2/5/2013

CHECKED BY XX DATE XXXX



ANOKA COUNTY  
HIGHWAY DEPT.

STATE PROJECT NO. \_\_\_\_\_

STATE AID PROJECT NO. \_\_\_\_\_







CITY PROJECT NO. \_\_\_\_\_

COUNTY PROJECT NO. CP 13-16-28

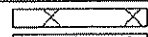
ALIGNMENT /  
CORE INFORMATION

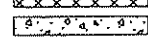
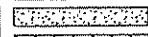
Sheet 13 of 26 Sheets

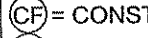

-  RECLAIM, PROFILE CORRECTION
-  FULL DEPTH RECLAIM / 4" OVERLAY
-  CONSTRUCT NEW RTL / BYPASS
-  BITUMINOUS REMOVAL
-  OVERLAY ST. APP.
-  REMOVE BIT / ADD GRVL / PAVE BIT ENT.
-  MILL JOINT
-  SILT FENCE
- ⊙ = GRAVEL   ⊕ = BITUMINOUS   ⊚ = CONCRETE
- ⊕ = CONSTRUCT NEW / MATCH FLUME
- ⊓ = INSTALL TRUNCATED DOME

REMOVE 66' CMP CULVERT  
 INSTALL 72' OF 24" RC PIPE CULVERT AND 2 - 6' - 24" RC PIPE APRONS  
 NEW TOTAL LENGTH END OF APRON TO END OF APRON 84'  
 INSTALL AT EXISTING DITCH ELEV.  
 MIN. 4:1 SLOPE FROM SH-PI

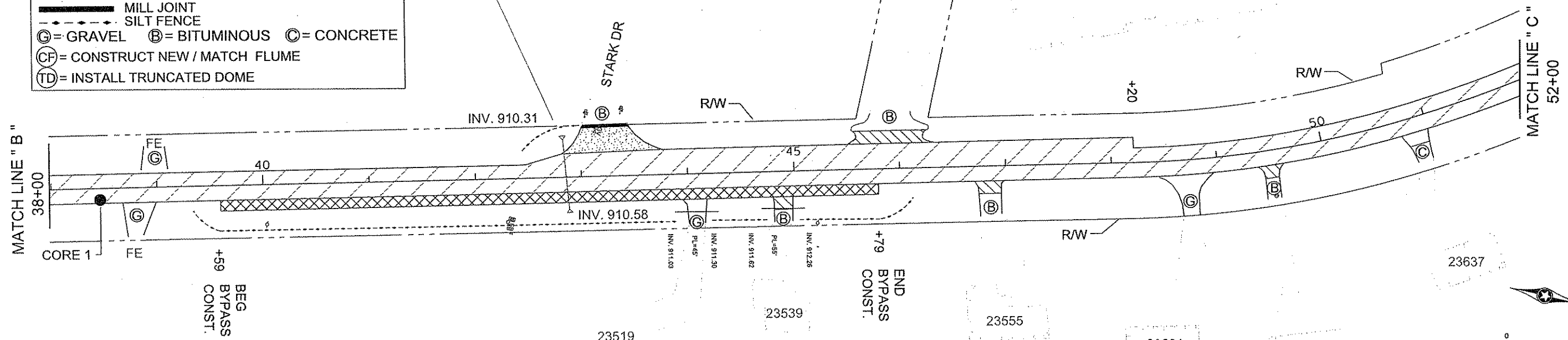

REMOVE EXISTING - CMP CULVERTS IN NEW RTL / BYPASS ENTRANCES  
 INSTALL NEW 15" CMP CULVERTS AND SAFETY APRONS  
 AS DIRECTED BY THE ENGINEER

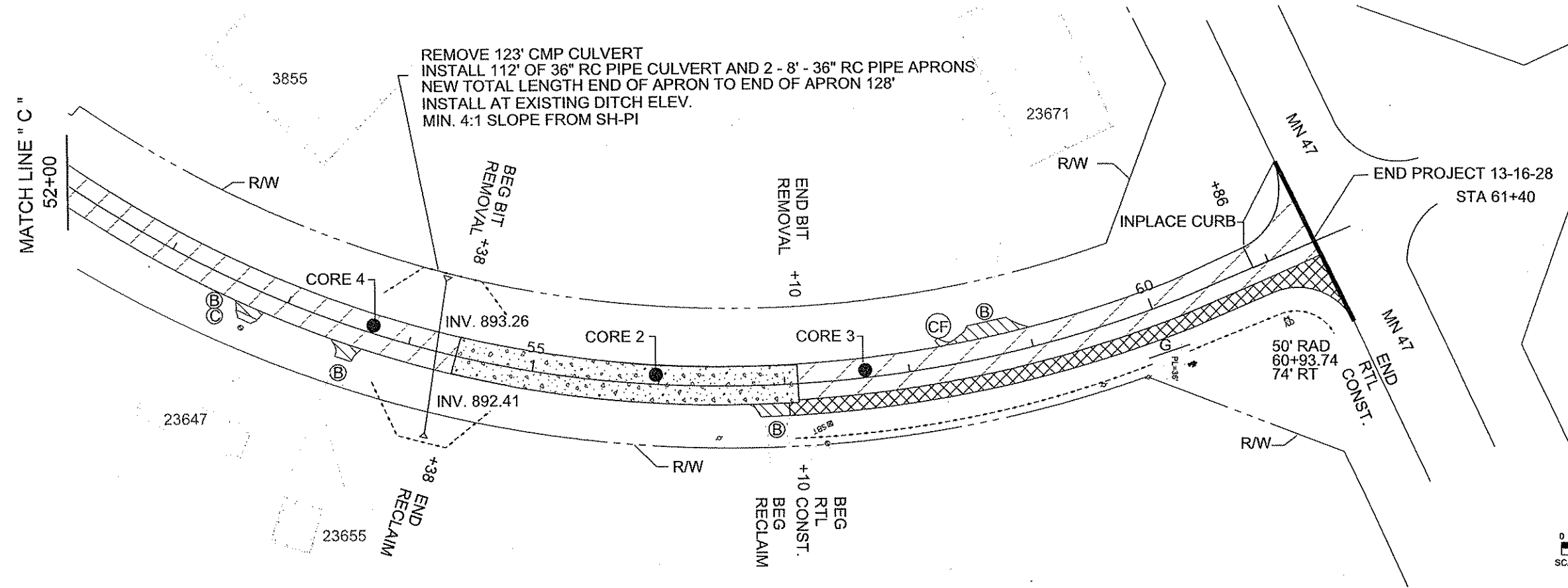

REMOVE 123' CMP CULVERT  
 INSTALL 112' OF 36" RC PIPE CULVERT AND 2 - 8' - 36" RC PIPE APRONS  
 NEW TOTAL LENGTH END OF APRON TO END OF APRON 128'  
 INSTALL AT EXISTING DITCH ELEV.  
 MIN. 4:1 SLOPE FROM SH-PI

NO	DATE	BY	CKD	APPR	REVISION

NAME: P:\13-01-00\CSAH\_28\_(CSAH24-TH47)\Plan9\_PLAN.dgn      02/28/2013      7:49:40 AM

I HEREBY CERTIFY THAT THIS PLAN WAS PREPARED BY ME OR UNDER MY DIRECT SUPERVISION AND THAT I AM A DULY LICENSED PROFESSIONAL ENGINEER UNDER THE LAWS OF THE STATE OF MINNESOTA.  
 PRINT NAME: ANDREW WALTER  
 SIGNATURE: *Andrew Walter*  
 DATE: 3/7/13      LICENSE NO. 42757

DRAWN BY: JF      DATE: 2/5/2013  
 DESIGN BY: JF      DATE: 2/5/2013  
 CHECKED BY: GA      DATE: 2/11/2013

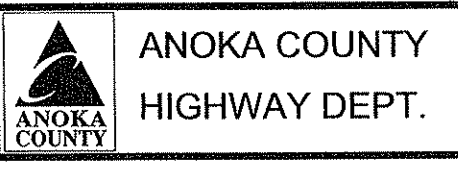

STATE PROJECT NO. \_\_\_\_\_  
 STATE AID PROJECT NO. \_\_\_\_\_  
 CITY PROJECT NO. \_\_\_\_\_  
 COUNTY PROJECT NO. CP 13-16-28

CONSTRUCTION PLAN  
 STA 38+00 TO 61+40  
 Sheet 15 of 25 Sheets



**PERMANENT PAVEMENT MARKING PLAN**  
NOTES AND GUIDELINES

**GENERAL INFORMATION:**

THE ENGINEER'S INVOLVEMENT IN THE APPLICATION OF THE MATERIAL SHALL BE LIMITED TO FIELD CONSULTATION AND INSPECTION. ANOKA COUNTY HIGHWAY DEPARTMENT WILL PLACE NECESSARY "SPOTTING" AT APPROPRIATE POINTS TO PROVIDE HORIZONTAL CONTROL FOR STRIPING AND TO DETERMINE NECESSARY STARTING AND CUTOFF POINTS, LONGITUDINAL JOINTS, PAVEMENT EDGES AND EXISTING MARKINGS MAY SERVE AS HORIZONTAL CONTROL WHEN SO DIRECTED.

EDGE LINES AND LANE LINES ARE TO BE BROKEN ONLY AT INTERSECTIONS WITH PUBLIC ROADS AND AT PRIVATE ENTRANCES IF THEY ARE CONTROLLED BY A YIELD SIGN, STOP SIGN OR TRAFFIC SIGNAL. THE BREAK POINT IS TO BE AT THE START OF THE RADIUS FOR THE INTERSECTION OR AT MARKED STOP LINES OR CROSSWALKS.

A TOLERANCE OF 1/4 INCH UNDER OR 1/4 INCH OVER THE SPECIFIED WIDTH WILL BE ALLOWED FOR STRIPING PROVIDED THE VARIATION IS GRADUAL AND DOES NOT DETRACT FROM THE GENERAL APPEARANCE. BROKEN LINE SEGMENTS MAY VARY UP TO ONE-HALF FOOT FROM THE SPECIFIED LENGTHS PROVIDED THE OVER AND UNDER VARIATIONS ARE REASONABLY COMPENSATORY. ALIGNMENT DEVIATIONS FROM THE CONTROL GUIDE SHALL NOT EXCEED 1 INCH. MATERIAL SHALL NOT BE APPLIED OVER LONGITUDINAL JOINTS, ESTABLISHMENT OF APPLICATION TOLERANCES SHALL NOT RELIEVE THE CONTRACTOR OF THEIR RESPONSIBILITY TO COMPLY AS CLOSELY AS PRACTICABLE WITH THE PLANNED DIMENSIONS.

**EPOXY:**

THE ROAD SURFACE SHALL BE CLEANED AT THE DIRECTION OF THE ENGINEER JUST PRIOR TO APPLICATION. PAVEMENT CLEANING SHALL CONSIST OF AT LEAST BRUSHING WITH A ROTARY BROOM (NON-METALLIC) OR AS RECOMMENDED BY THE MATERIAL MANUFACTURER AND ACCEPTABLE TO THE ENGINEER. NEW PORTLAND CEMENT CONCRETE SURFACES SHALL BE SANDBLAST CLEANED TO REMOVE ANY SURFACE TREATMENT AND/OR LAITANCE ON LOW SPEED (SPEED LIMIT 35 MPH OR LESS) URBAN PORTLAND CEMENT CONCRETE ROADWAYS. SANDBLAST CLEANING SHALL BE USED FOR ALL EPOXY PAVEMENT MARKINGS.

THE EPOXY MARKING APPLICATION SHALL IMMEDIATELY FOLLOW THE PAVEMENT CLEANING. GLASS BEANS SHALL BE APPLIED IMMEDIATELY AFTER APPLICATION OF THE EPOXY RESIN LINE TO PROVIDE AN IMMEDIATE NO-TRACK SYSTEM.

AN EPOXY RESIN LINE 4" WIDE AND 15 MILL THICKNESS (WET), REQUIRES AN APPLICATION RATE OF ONE (1) GALLON OF COMPONENTS FOR 320 FEET OF LINE. GLASS BEADS SHALL BE APPLIED AT A POUND PER GALLON RATE SUFFICIENT TO ACHIEVE AN ACCEPTABLE NO-TRACK SYSTEM.

OPERATIONS SHALL BE CONDUCTED ONLY WHEN THE ROAD PAVEMENT SURFACE TEMPERATURES ARE 50 DEGREES FAHRENHEIT OR GREATER.

PERMANENT PAVEMENT MARKINGS SHALL NOT BE PLACED OVER TEMPORARY TAPE MARKINGS.

**PREFORMED THERMOPLASTIC:**

THE PREFORMED THERMOPLASTIC MARKINGS SHALL BE APPLIED IN ACCORDANCE WITH THE MANUFACTURER'S RECOMMENDATIONS ON CLEAN AND DRY SURFACES. SEE SPECIAL PROVISIONS FOR PREFORMED THERMOPLASTIC MARKING SPECIFICATIONS.

**PAINT:**

AT THE TIME OF APPLYING THE MARKING MATERIAL, THE APPLICATION AREA SHALL BE FREE OF CONTAMINATION. THE CONTRACTOR SHALL CLEAN THE ROADWAY SURFACE PRIOR TO THE LINE APPLICATION IN A MANNER AND TO THE EXTENT REQUIRED BY THE ENGINEER.

GLASS BEADS SHALL BE APPLIED IMMEDIATELY AFTER APPLICATION OF THE PAINT LINE.

EXCEPT WHEN USED AS A TEMPORARY MARKING, PAVEMENT MARKINGS SHALL ONLY BE APPLIED IN SEASONABLE WEATHER WHEN AIR TEMPERATURE IS 50 DEGREES FARHENHEIT OR HIGHER AND SHALL NOT BE APPLIED WHEN THE WIND OR OTHER CONDITIONS CAUSE A FILD OR DUST TO BE DEPOSITED ON THE PAVEMENT SURFACE AFTER CLEANING AND BEFORE THE MARKING MATERIAL CAN BE APPLIED.

THE FILLING OF TANKS, POURING OF MATERIALS OR CLEANING OF EQUIPMENT SHALL NOT BE PERFORMED ON UNPROTECTED PAVEMENT SURFACES UNLESS ADEQUATE PROVISIONS ARE MADE TO PREVENT SPILLAGE OF MATERIAL.

**SYMBOLS & MATERIALS LEGEND**

■ CROSSWALK BLOCK WHITE PREFORMED THERMOPLASTIC

↖ PAVEMENT MESSAGE (LEFT ARROW) PREFORMED THERMOPLASTIC

**STRIPING KEY**

○ CIRCLE - EPOXY      □ SQUARE PREFORMED THERMOPLASTIC

△ TRIANGLE - PAINT

⬠ PENTAGON - REMOVABLE PREFORMED PLASTIC MARKING

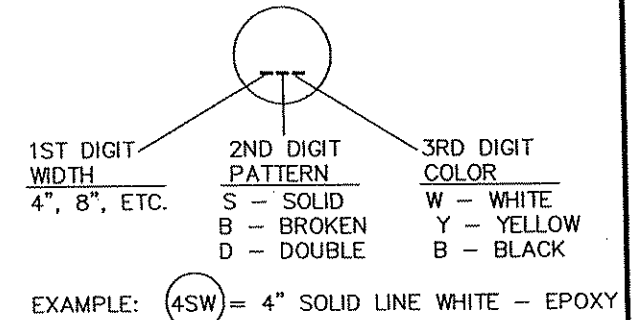

**PAVEMENT MARKING QUANTITIES**

Item	Quantity	Units
12" White Thermoplastic	85	Lin Ft
24" White Thermoplastic	43	Lin Ft
4" Solid Line White - Epoxy	10103	Lin Ft
4" Broken Line White - Epoxy (10 ft stripe / 40 ft gap)	40	Lin Ft
4" Solid Line Yellow - Epoxy	1102	Lin Ft
4" Broken Yellow Striping	570	Lin Ft
4" Double Solid Line Yellow - Epoxy	2126	Lin Ft

NO	DATE	BY	CKD	APPR	REVISION

I HEREBY CERTIFY THAT THIS PLAN WAS PREPARED BY ME OR UNDER MY DIRECT SUPERVISION AND THAT I AM A DULY LICENSED PROFESSIONAL ENGINEER UNDER THE LAWS OF THE STATE OF MINNESOTA.  
 PRINT NAME: ANDREW WITTE  
 SIGNATURE: *[Signature]*  
 DATE: 3/11/13 LICENSE NO. 42757

DRAWN BY: MTH DATE 12/27/2012  
 DESIGN BY: MTH DATE 12/27/2012  
 CHECKED BY: JR DATE 02/25/2013



**ANOKA COUNTY**  
**HIGHWAY DEPT.**

STATE PROJECT NO. \_\_\_\_\_  
 STATE AID PROJECT NO. \_\_\_\_\_  
 STATE AID PROJECT NO. \_\_\_\_\_  
 COUNTY PROJECT NO. 13-16-28

**PERMANENT MARKING**  
**TABULATION**  
 Sheet 16 of 25 Sheets

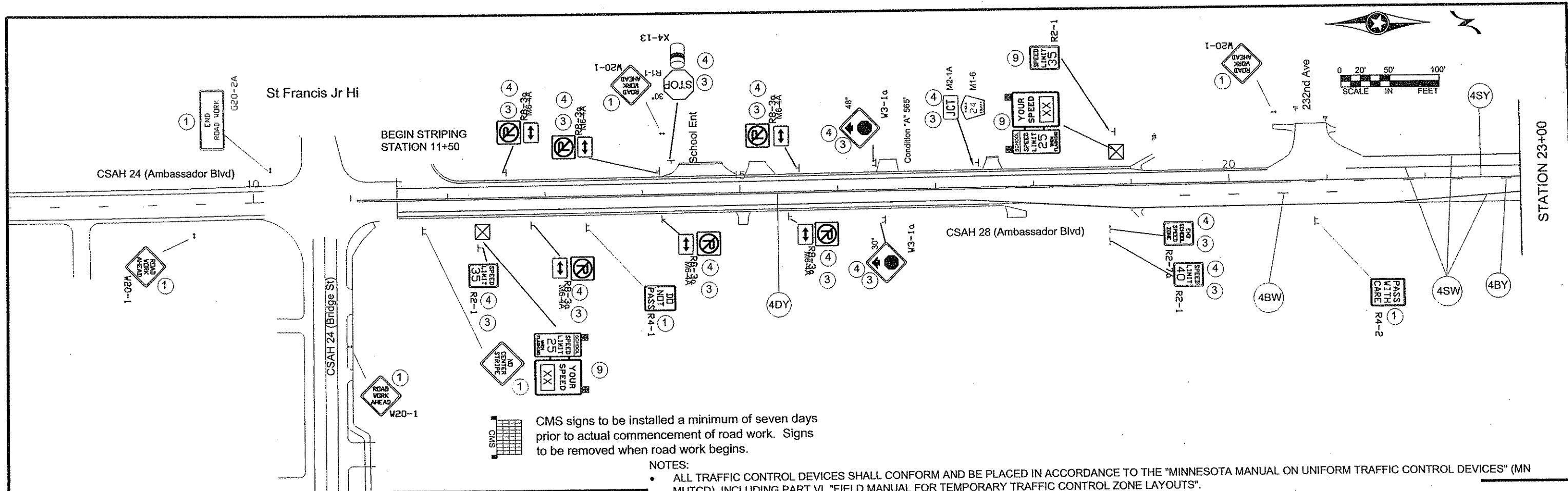

CMS signs to be installed a minimum of seven days prior to actual commencement of road work. Signs to be removed when road work begins.

**NOTES:**

- ALL TRAFFIC CONTROL DEVICES SHALL CONFORM AND BE PLACED IN ACCORDANCE TO THE "MINNESOTA MANUAL ON UNIFORM TRAFFIC CONTROL DEVICES" (MN MUTCD), INCLUDING PART VI, "FIELD MANUAL FOR TEMPORARY TRAFFIC CONTROL ZONE LAYOUTS".
- CONTRACTOR SHALL COMPLY WITH THE LONGITUDINAL DROP-OFF GUIDELINES AS PER THE FIELD MANUAL.
- LOCATIONS OF PAVEMENT MARKINGS ARE APPROXIMATE. EXACT LOCATIONS WILL BE DETERMINED IN THE FIELD BY THE ENGINEER.
- CONTRACTOR SHALL SUPPLY AND INSTALL THE PORTABLE CHANGEABLE MESSAGE SIGN (CMS) A MINIMUM OF SEVEN DAYS PRIOR TO ACTUAL COMMENCEMENT OF ROAD WORK, TO A LOCATION AS SPECIFIED BY THE ENGINEER. SIGNS TO BE REMOVED WHEN ROAD WORK BEGINS. PAYMENT SHALL BE MADE AS PER ITEM 2563.613 PORTABLE CHANGEABLE MESSAGE SIGN BY THE UNIT/DAY.
- CONTRACTOR SHALL SUPPLY AND ERECT THE TEMPORARY TRAFFIC CONTROL SIGNS AS SHOWN ON THIS DRAWING AND DETAILED IN THE SPECIAL PROVISIONS FROM THE TIME WORK COMMENCES ON THIS ROADWAY UNTIL THIS ROADWAY IS PERMANENTLY STRIPED. ALL NECESSARY TEMPORARY TRAFFIC CONTROL SIGNS SHALL BE PAID FOR AS PART OF TRAFFIC CONTROL LUMP SUM.
- ALL PERMANENT STRIPING AND PAVEMENT MESSAGES SHALL BE PLACED WITHIN 72 HOURS OF MAINLINE PAVING.
- ANY REQUIRED PERMANENT SIGNING SHALL BE INSTALLED THE SAME DAY AS PERMANENT STRIPING
- ALL EXISTING SIGNING SHALL REMAIN IN PLACE DURING CONSTRUCTION. ALL SALVAGED AND REINSTALLED SIGNS SHALL BE INSTALLED ON TEMPORARY SUPPORTS UNTIL THE PERMANENT INSTALLATION CAN BE MADE. THIS WILL BE CONSIDERED AS INCIDENTAL TO INSTALL SIGN TYPE C.

**SIGNING NOTES:**

- ① TEMPORARY TRAFFIC CONTROL SIGN
- ② FURNISH AND INSTALL PERMANENT SIGN
- ③ SALVAGE SIGN TYPE C
- ④ INSTALL SIGN TYPE C
- ⑤ INPLACE SIGN - LEAVE IN PLACE

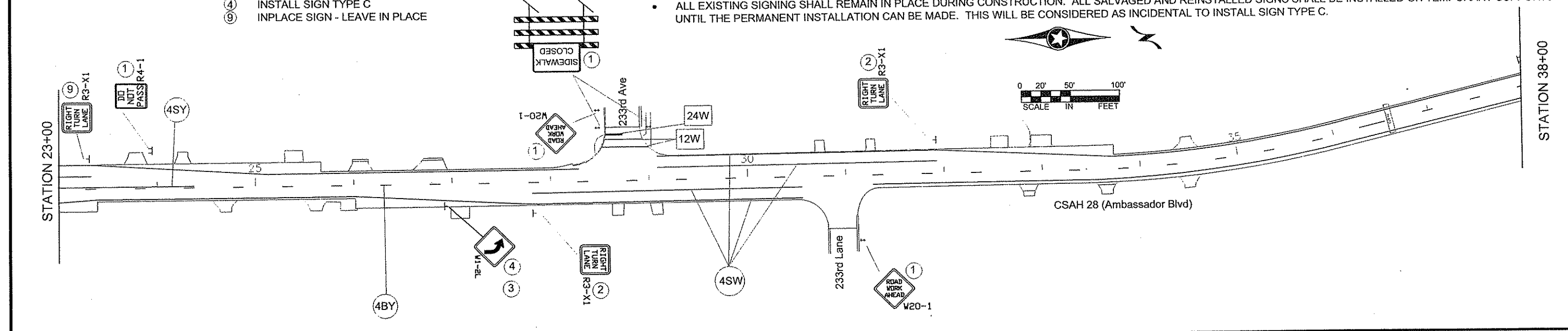

NO	DATE	BY	CHKD	APPR	REVISION

I HEREBY CERTIFY THAT THIS PLAN WAS PREPARED BY ME OR UNDER MY DIRECT SUPERVISION AND THAT I AM A DULY REGISTERED PROFESSIONAL ENGINEER UNDER THE LAWS OF THE STATE OF MINNESOTA.  
 PRINT NAME: ANDREW WINTER  
 SIGNATURE: *[Signature]*  
 DATE: 3/13/13 REG. NO. 42757

DRAWN BY: MTH DATE 12/27/2012  
 DESIGN BY: MTH DATE 12/27/2012  
 CHECKED BY: JR DATE 2/25/2013

**ANOKA COUNTY**  
**HIGHWAY DEPT.**

STATE PROJECT NO. \_\_\_\_\_  
 STATE AID PROJECT NO. \_\_\_\_\_  
 STATE AID PROJECT NO. \_\_\_\_\_  
 COUNTY PROJECT NO. 13-16-28

TEMPORARY SIGNING  
 PERMANENT SIGNING, STRIPING  
 AND PAVEMENT MESSAGES  
 Sheet 17 of 25 Sheets

NOTES:

- ALL TRAFFIC CONTROL DEVICES SHALL CONFORM AND BE PLACED IN ACCORDANCE TO THE "MINNESOTA MANUAL ON UNIFORM TRAFFIC CONTROL DEVICES" (MN MUTCD), INCLUDING PART VI, "FIELD MANUAL FOR TEMPORARY TRAFFIC CONTROL ZONE LAYOUTS".
- CONTRACTOR SHALL COMPLY WITH THE LONGITUDINAL DROP-OFF GUIDELINES AS PER THE FIELD MANUAL.
- LOCATIONS OF PAVEMENT MARKINGS ARE APPROXIMATE. EXACT LOCATIONS WILL BE DETERMINED IN THE FIELD BY THE ENGINEER.
- CONTRACTOR SHALL SUPPLY AND INSTALL THE PORTABLE CHANGEABLE MESSAGE SIGN (CMS) A MINIMUM OF SEVEN DAYS PRIOR TO ACTUAL COMMENCEMENT OF ROAD WORK, TO A LOCATION AS SPECIFIED BY THE ENGINEER. SIGNS TO BE REMOVED WHEN ROAD WORK BEGINS. PAYMENT SHALL BE MADE AS PER ITEM 2563.613 PORTABLE CHANGEABLE MESSAGE SIGN BY THE UNIT/DAY.
- CONTRACTOR SHALL SUPPLY AND ERECT THE TEMPORARY TRAFFIC CONTROL SIGNS AS SHOWN ON THIS DRAWING AND DETAILED IN THE SPECIAL PROVISIONS FROM THE TIME WORK COMMENCES ON THIS ROADWAY UNTIL THIS ROADWAY IS PERMANENTLY STRIPED. ALL NECESSARY TEMPORARY TRAFFIC CONTROL SIGNS SHALL BE PAID FOR AS PART OF TRAFFIC CONTROL LUMP SUM.
- ALL PERMANENT STRIPING AND PAVEMENT MESSAGES SHALL BE PLACED WITHIN 72 HOURS OF MAINLINE PAVING.
- ANY REQUIRED PERMANENT SIGNING SHALL BE INSTALLED THE SAME DAY AS PERMANENT STRIPING
- ALL EXISTING SIGNING SHALL REMAIN IN PLACE DURING CONSTRUCTION. ALL SALVAGED AND REINSTALLED SIGNS SHALL BE INSTALLED ON TEMPORARY SUPPORTS UNTIL THE PERMANENT INSTALLATION CAN BE MADE. THIS WILL BE CONSIDERED AS INCIDENTAL TO INSTALL SIGN TYPE C.

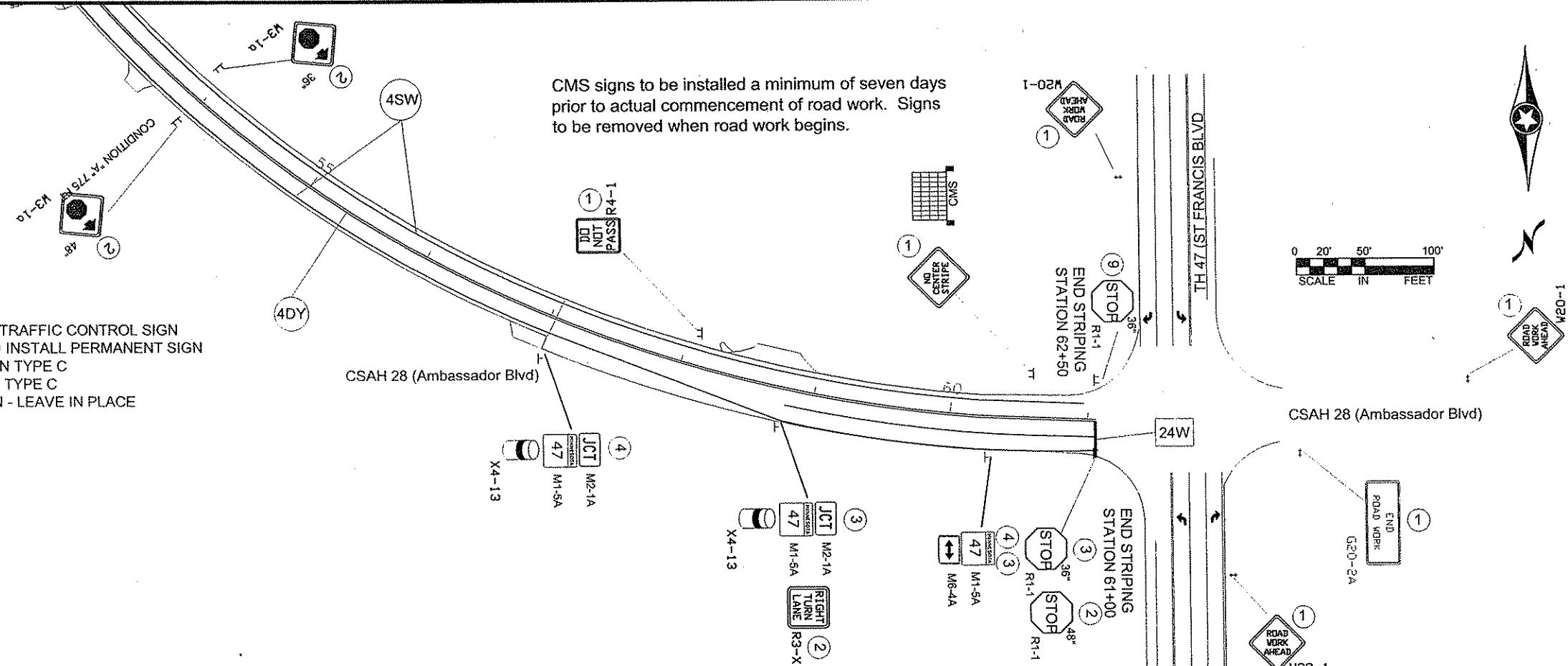
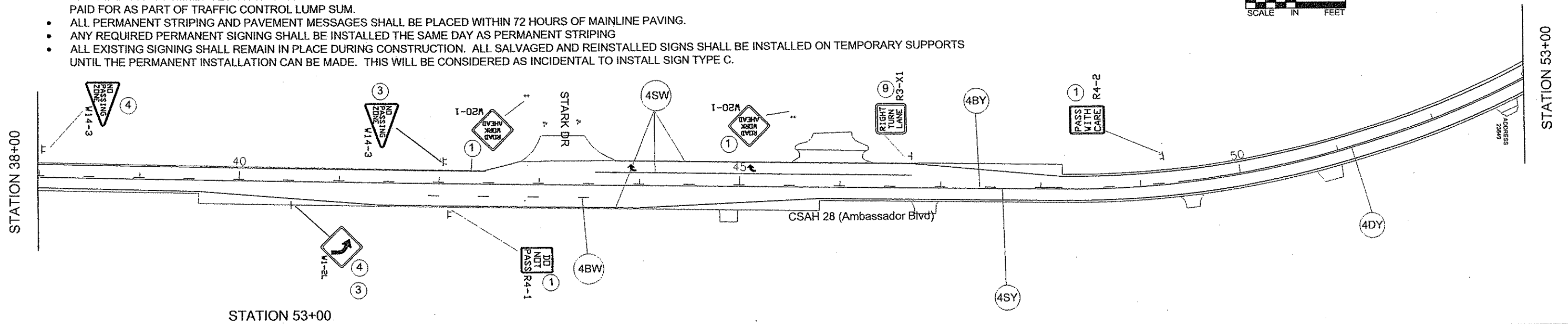
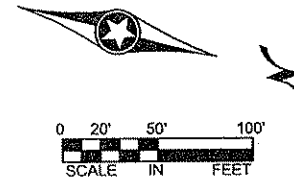

CMS signs to be installed a minimum of seven days prior to actual commencement of road work. Signs to be removed when road work begins.

SIGNING NOTES:

- ① TEMPORARY TRAFFIC CONTROL SIGN
- ② FURNISH AND INSTALL PERMANENT SIGN
- ③ SALVAGE SIGN TYPE C
- ④ INSTALL SIGN TYPE C
- ⑨ INPLACE SIGN - LEAVE IN PLACE

NO	DATE	BY	CKD	APPR	REVISION

I HEREBY CERTIFY THAT THIS PLAN WAS PREPARED BY ME OR UNDER MY DIRECT SUPERVISION AND THAT I AM A DULY REGISTERED PROFESSIONAL ENGINEER UNDER THE LAWS OF THE STATE OF MINNESOTA.  
 PRINT NAME: ANDREW WALTER  
 SIGNATURE: *[Signature]*  
 DATE: 3/17/13 REG. NO. 42757

DRAWN BY: MTH DATE 12/27/2012  
 DESIGN BY: MTH DATE 12/27/2012  
 CHECKED BY: JR DATE 2/25/2013

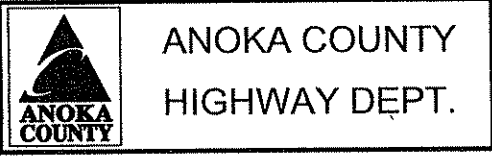

STATE PROJECT NO. \_\_\_\_\_  
 STATE AID PROJECT NO. \_\_\_\_\_  
 STATE AID PROJECT NO. \_\_\_\_\_  
 COUNTY PROJECT NO. 13-16-28

TEMPORARY SIGNING  
 PERMANENT SIGNING, STRIPING  
 AND PAVEMENT MESSAGES  
 Sheet 18 of 25 Sheets

F & I PERMANENT SIGNS						
M.U.T.C.D. CODE	SIZE	PANEL AREA FT. <sup>2</sup>	INSERT	QUANTITY	No. POST	MOUNTING HEIGHT TO SIGN TOP (ft.)
R1-1	48" x 48"	16.00		1	2	7.0'
R3-X1	30" x 30"	6.25		3	1	7.0'
W3-1a	36" x 36"	9.00		1	2	7.0'
W3-1a	48" x 48"	16.00		1	2	7.0'

Item	Quantity	Units
SALVAGE SIGN PANEL TYPE C	19	EACH
SIGN PANEL TYPE C	43.75	SQ FT
INSTALL SIGN PANEL TYPE C	19	EACH

TEMPORARY TRAFFIC CONTROL SIGNS						
M.U.T.C.D. CODE	SIZE	PANEL AREA FT. <sup>2</sup>	INSERT	QUANTITY	No. POST	MOUNTING HEIGHT TO SIGN TOP (ft.)
W8-12	48" x 48"	16.00		2	2	7.0'
R4-1	24" x 30"	5.00		4	1	7.0'
R4-2	24" x 30"	5.00		2	1	7.0'
W8-1A	48" x 48"	16.00		AS NEEDED		
W8-1A	48" x 48"	16.00		AS NEEDED		
W8-8	48" x 48"	16.00		AS NEEDED		
W8-9	48" x 48"	16.00		AS NEEDED		
	48" x 48"	16.00		AS NEEDED		
W8-11	48" x 48"	16.00		AS NEEDED		
W8-11	48" x 48"	16.00		AS NEEDED (ESTIMATED 11)		
CMS signs to be installed a minimum of seven days prior to actual commencement of road work. Signs to be removed when road work begins.						2
R11-11	30" x 18"	3.75		AS NEEDED (ESTIMATED 2)		
TYPE 3	4' x 8'			AS NEEDED (ESTIMATED 2)		
G20-2A	48" x 24"	8.00		2		

NOTES:

- ALL TRAFFIC CONTROL DEVICES SHALL CONFORM AND BE PLACED IN ACCORDANCE TO THE "MINNESOTA MANUAL ON UNIFORM TRAFFIC CONTROL DEVICES" (MN MUTCD), INCLUDING PART VI, "FIELD MANUAL FOR TEMPORARY TRAFFIC CONTROL ZONE LAYOUTS".
- CONTRACTOR SHALL COMPLY WITH THE LONGITUDINAL DROP-OFF GUIDELINES AS PER THE FIELD MANUAL.
- LOCATIONS OF PAVEMENT MARKINGS ARE APPROXIMATE. EXACT LOCATIONS WILL BE DETERMINED IN THE FIELD BY THE ENGINEER.
- CONTRACTOR SHALL SUPPLY AND INSTALL THE PORTABLE CHANGEABLE MESSAGE SIGN (CMS) A MINIMUM OF SEVEN DAYS PRIOR TO ACTUAL COMMENCEMENT OF ROAD WORK, TO A LOCATION AS SPECIFIED BY THE ENGINEER. SIGNS TO BE REMOVED WHEN ROAD WORK BEGINS. PAYMENT SHALL BE MADE AS PER ITEM 2563.613 PORTABLE CHANGEABLE MESSAGE SIGN BY THE UNIT/DAY.
- CONTRACTOR SHALL SUPPLY AND ERECT THE TEMPORARY TRAFFIC CONTROL SIGNS AS SHOWN ON THIS DRAWING AND DETAILED IN THE SPECIAL PROVISIONS FROM THE TIME WORK COMMENCES ON THIS ROADWAY UNTIL THIS ROADWAY IS PERMANENTLY STRIPED. ALL NECESSARY TEMPORARY TRAFFIC CONTROL SIGNS SHALL BE PAID FOR AS PART OF TRAFFIC CONTROL LUMP SUM.
- ALL PERMANENT STRIPING AND PAVEMENT MESSAGES SHALL BE PLACED WITHIN 72 HOURS OF MAINLINE PAVING.
- ANY REQUIRED PERMANENT SIGNING SHALL BE INSTALLED THE SAME DAY AS PERMANENT STRIPING
- ALL EXISTING SIGNING SHALL REMAIN IN PLACE DURING CONSTRUCTION. ALL SALVAGED AND REINSTALLED SIGNS SHALL BE INSTALLED ON TEMPORARY SUPPORTS UNTIL THE PERMANENT INSTALLATION CAN BE MADE. THIS WILL BE CONSIDERED AS INCIDENTAL TO INSTALL SIGN TYPE C.

SALVAGE AND RE-INSTALL PERM SIGNS				
STATION		SALVAGE SIGN TYPE C	INSTALL SIGN TYPE C	SIGN NUMBER
		EACH	EACH	
12+30	Rt	1	1	R2-1
12+60	Lt	1	1	R8-3a M6-4a
12+80	Rt	1	1	R8-3a M6-4a
14+20	Rt	1	1	R8-3a M6-4a
14+20	Lt	1	1	R8-3a M6-4a
14+30	Rt	1	1	R1-1 delineator
15+40	Rt	1	1	R8-3a M6-4a
15+40	Lt	1	1	R8-3a M6-4a
16+50	Rt	1	1	W3-1a
16+50	Lt	1	1	W3-1a
17+40	Lt	1	1	M2-1a M1-6
18+70	Rt	1	1	R2-7a
18+70	Rt	1	1	R2-1
26+90	Rt	1	1	W1-2L
38+00	Lt		1	W14-3
40+50	Rt	1	1	W1-2L
42+00	Lt	1		W14-3
57+00	Rt		1	M2-1A M1-5A delineator
57+00	Rt	1		M2-1A M1-5A delineator
60+30	Rt	1	1	M1-5A M6-4A
61+00	Rt	1	1	R1-1
TOTAL		19	19	

I HEREBY CERTIFY THAT THIS PLAN WAS PREPARED BY ME OR UNDER MY DIRECT SUPERVISION AND THAT I AM A DULY REGISTERED PROFESSIONAL ENGINEER UNDER THE LAWS OF THE STATE OF MINNESOTA. PRINT NAME: ANDREW WITTSER SIGNATURE: DATE: 3/13/13 REG. NO. 42757					DRAWN BY: MTH DATE 12/27/2012 DESIGN BY: MTH DATE 12/27/2012 CHECKED BY: JR DATE 2/25/2013		ANOKA COUNTY HIGHWAY DEPT.		STATE PROJECT NO. _____ STATE AID PROJECT NO. _____ STATE AID PROJECT NO. _____ COUNTY PROJECT NO. 13-16-28		TRAFFIC CONTROL QUANTITIES Sheet 19 of 25 Sheets	
NO	DATE	BY	CKD	APPR	REVISION							



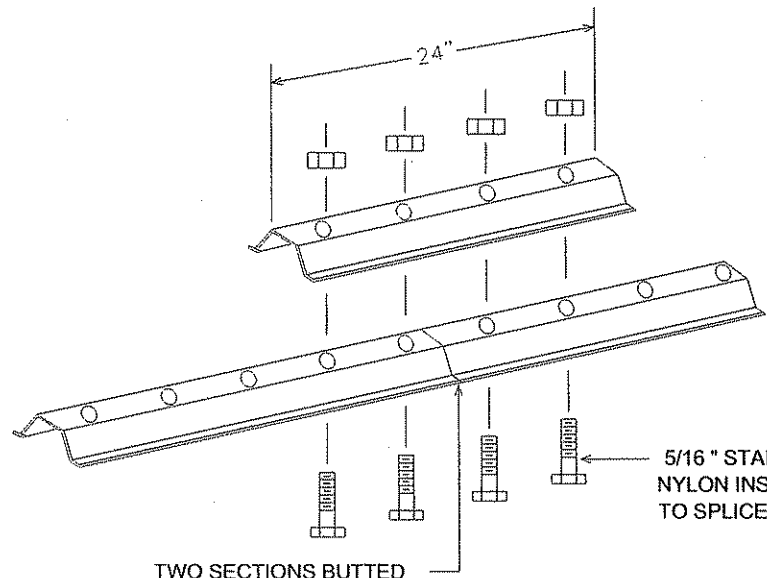

LATERAL BRACE OR STRINGER  
SPLICE DETAIL (EXPLODED VIEW)

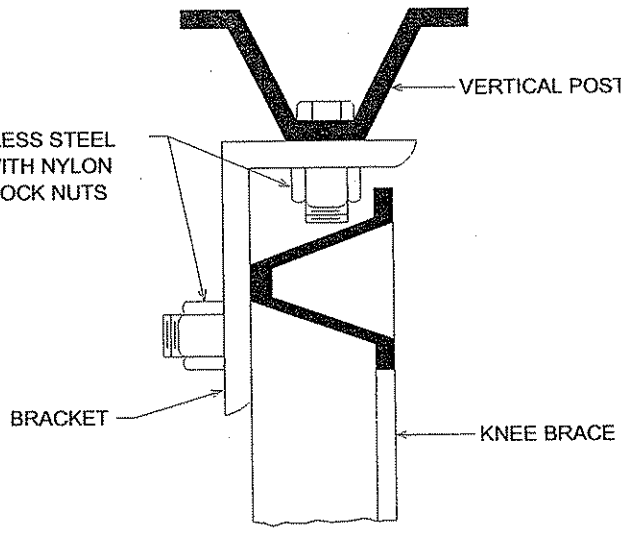

SECTION A-A

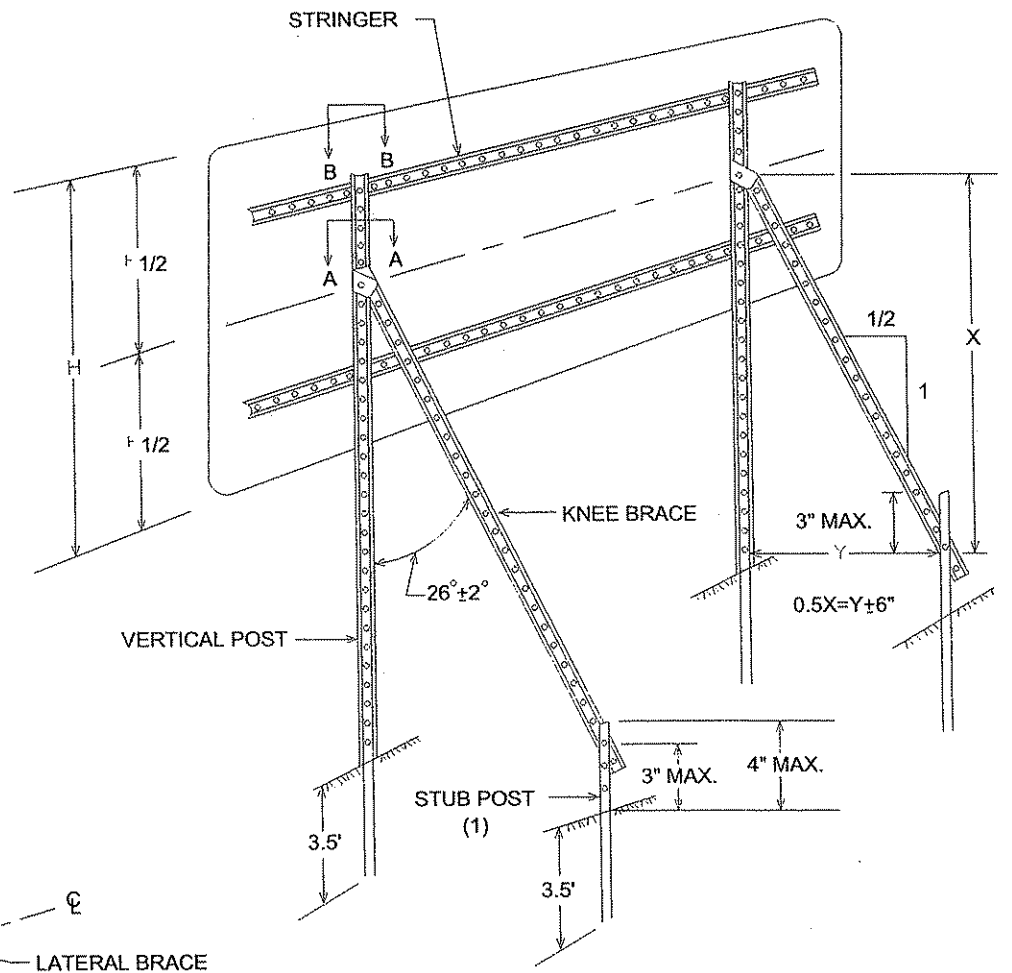

TYPICAL "A-FRAME" INSTALLATION  
TYPE "D" SIGNS

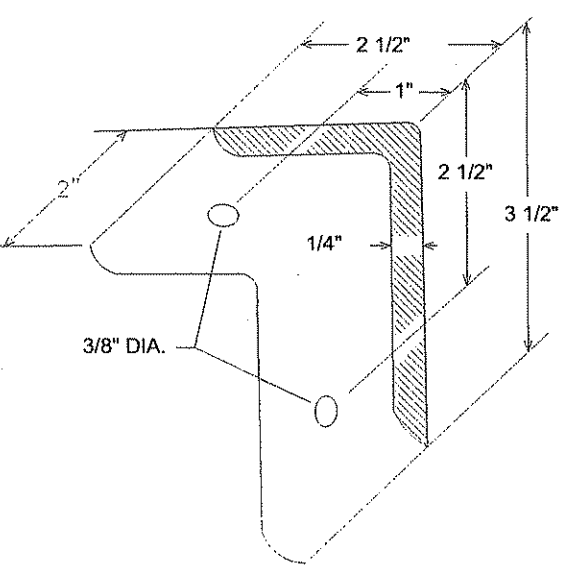

A-FRAME BRACKET

(STEEL MN/DOT 3306 GALVANIZED PER MN/DOT 3394)

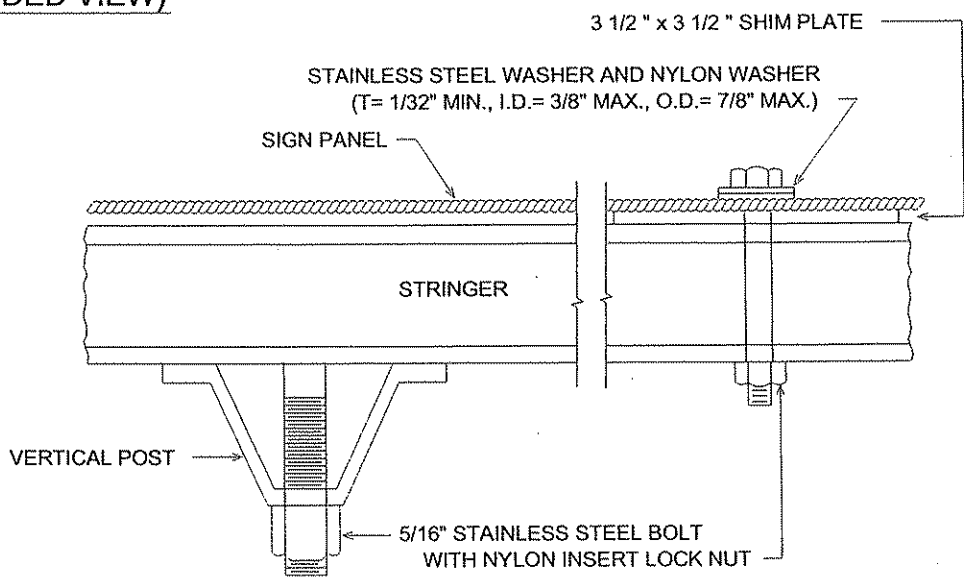

SECTION B-B

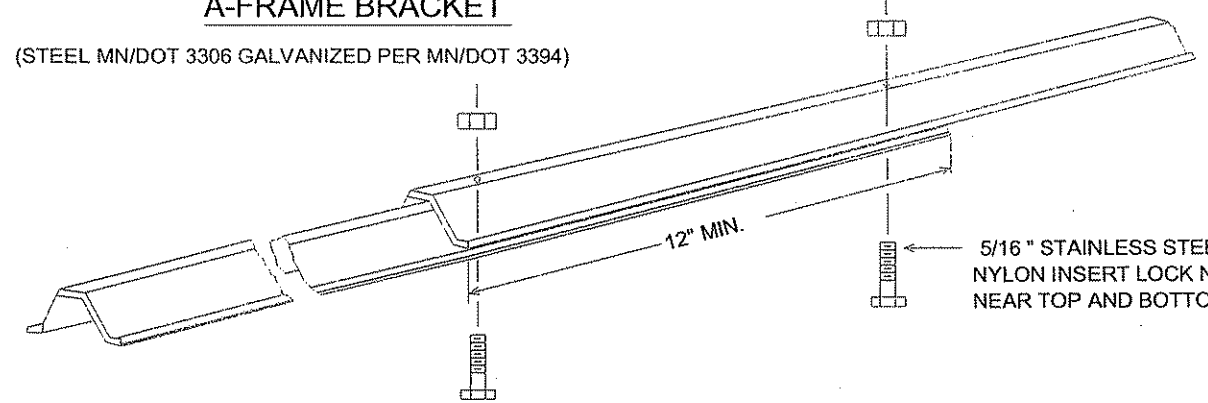

KNEE BRACE SPLICE

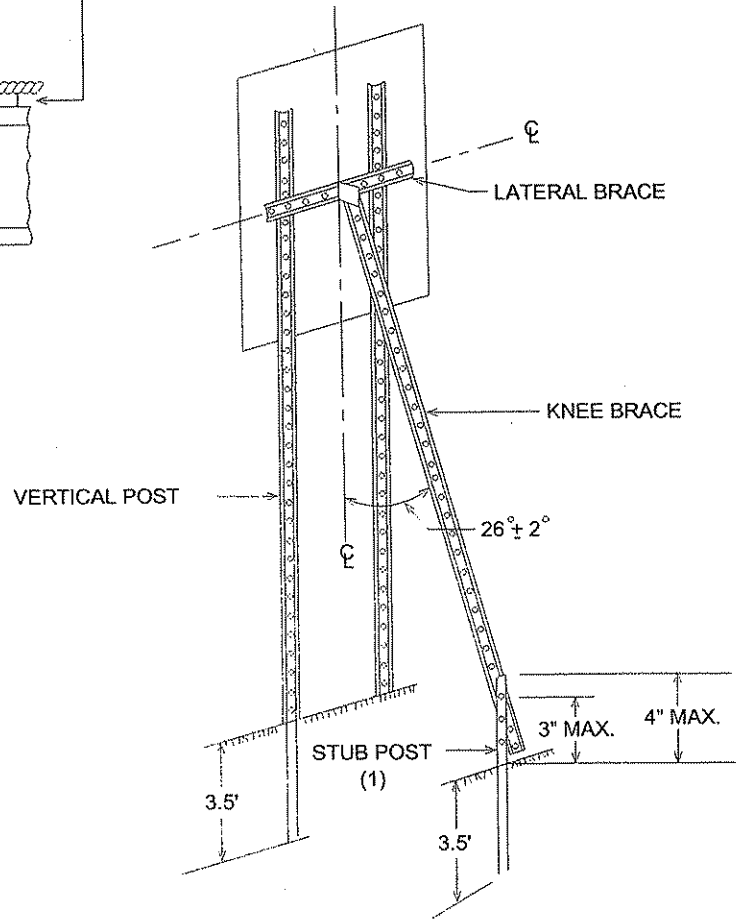

TYPICAL "A-FRAME" INSTALLATION  
TYPE "C" SIGNS

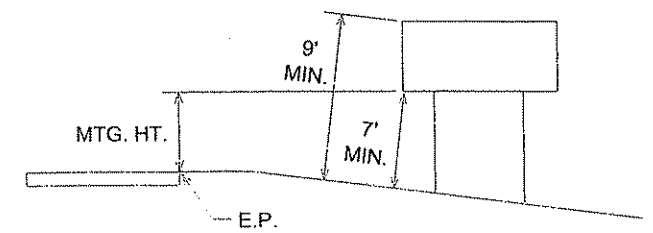

TYPICAL MOUNTING

(1) OFFSET STUB POST 1' TOWARD ROADWAY  
RELATIVE TO VERTICAL POST.

TYPE C & D SIGN  
STRUCTURAL DETAILS

NO	DATE	BY	CKD	APPR	REVISION

I HEREBY CERTIFY THAT THIS PLAN WAS PREPARED BY ME OR UNDER MY DIRECT SUPERVISION AND THAT I AM A DULY LICENSED PROFESSIONAL ENGINEER UNDER THE LAWS OF THE STATE OF MINNESOTA.  
 PRINT NAME: ANDREW WITTE  
 SIGNATURE: *Andrew Witte*  
 DATE: 3/7/13 LICENSE NO. 42757

DRAWN BY MTH DATE 2-10-13  
 DESIGN BY MTH DATE 2-10-13  
 CHECKED BY JR DATE 1-21-11

**ANOKA COUNTY**  
**HIGHWAY DEPT.**

STATE PROJECT NO. \_\_\_\_\_  
 STATE PROJECT NO. \_\_\_\_\_  
 STATE PROJECT NO. \_\_\_\_\_  
 COUNTY PROJECT NO. 13-16-28

SIGNING & STRIPING DETAILS  
 Sheet 20 of 25 Sheets

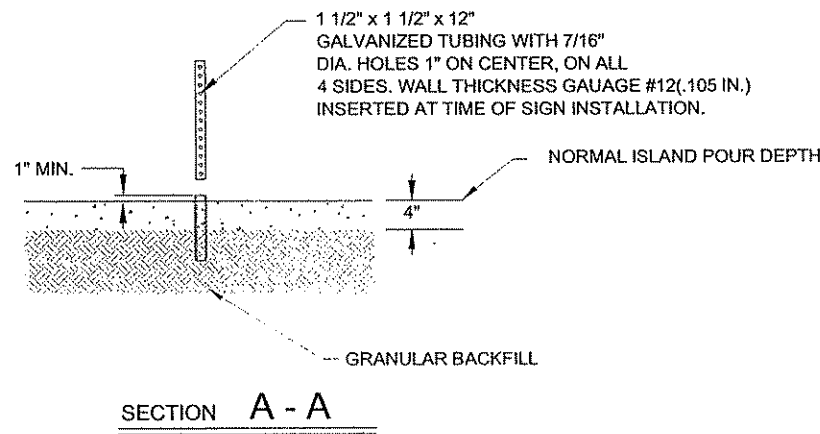
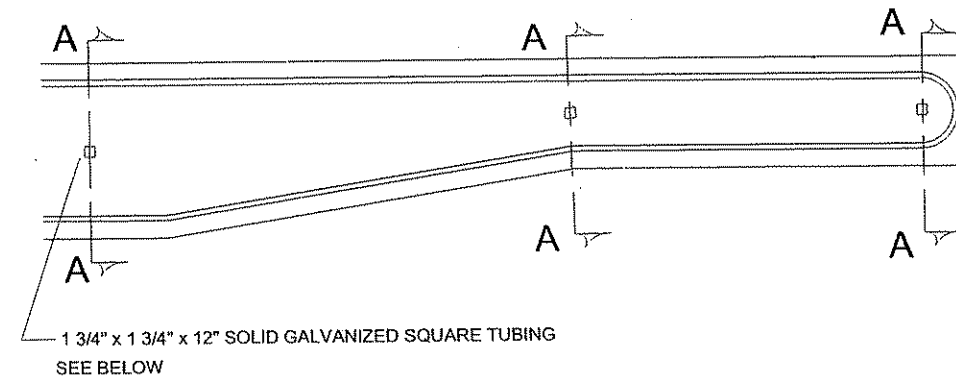

GROUND POST MOUNT SIGN  
INSTALLATION TYPICAL

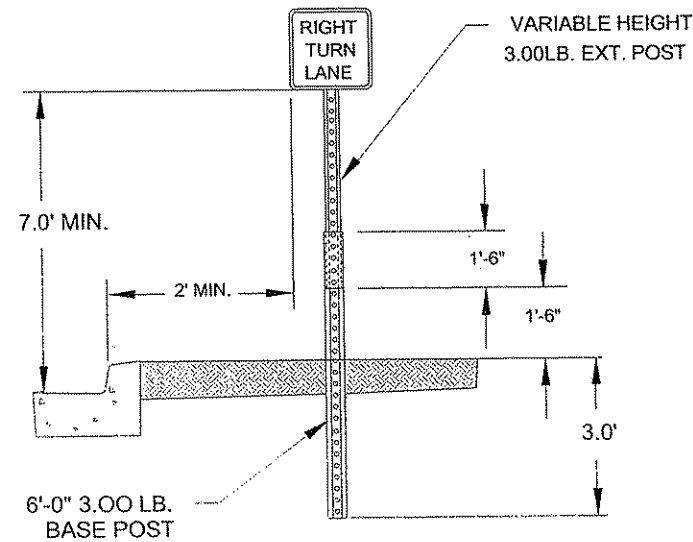

ISLAND MOUNT BREAK-AWAY SIGN  
INSTALLATION TYPICAL

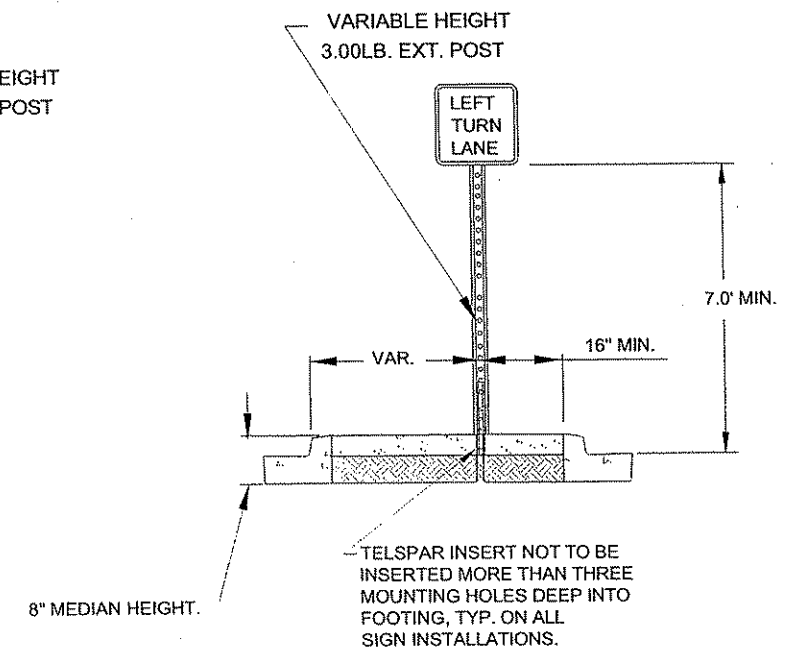

NO	DATE	BY	CHKD	APPR	REVISION

I HEREBY CERTIFY THAT THIS PLAN WAS PREPARED BY ME OR UNDER MY DIRECT SUPERVISION AND THAT I AM A DULY LICENSED PROFESSIONAL ENGINEER UNDER THE LAWS OF THE STATE OF MINNESOTA.  
 PRINT NAME: ANDREW BITTER  
 SIGNATURE: *Andrew Bitter*  
 DATE: 3/7/13 LICENSE NO. 42757

DRAWN BY: MTH DATE: 2-10-13  
 DESIGN BY: MTH DATE: 2-10-13  
 CHECKED BY: JR DATE: 1-21-11



ANOKA COUNTY  
HIGHWAY DEPT.

STATE PROJECT NO. \_\_\_\_\_  
 STATE PROJECT NO. \_\_\_\_\_  
 STATE PROJECT NO. \_\_\_\_\_  
 COUNTY PROJECT NO. 13-16-28

SIGNING & STRIPING DETAILS  
 Sheet 21 of 25 Sheets

RURAL

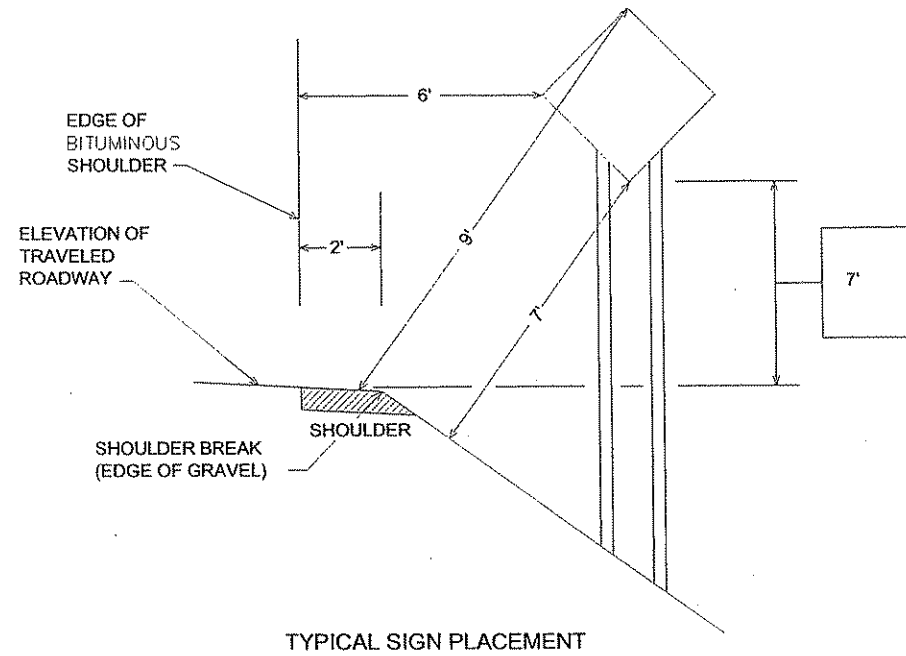

TYPICAL SIGN PLACEMENT

URBAN

2' - NARROW BOULEVARD (< 8' WIDE)  
6' - WIDE BOULEVARD

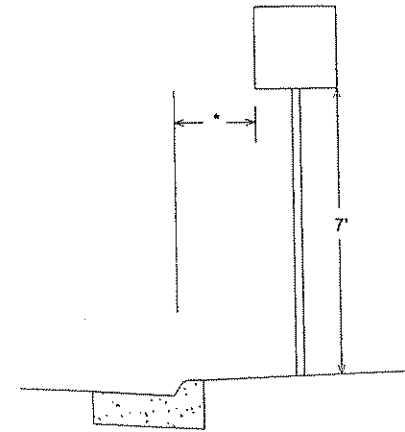

TYPICAL SIGN PLACEMENT

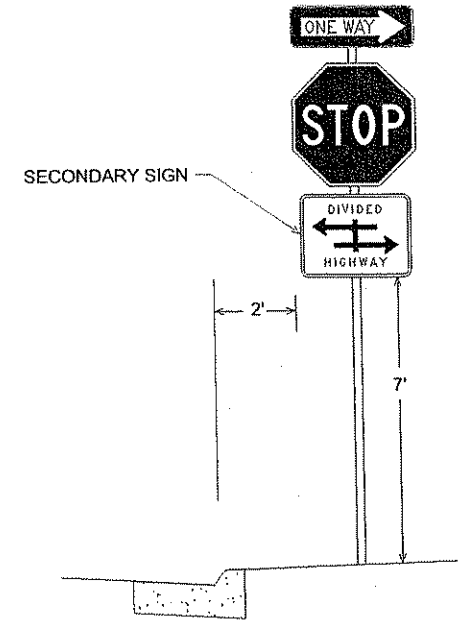

NOTE:

- ALL DIMENSIONS ARE MINIMUMS
- MAINTAIN 2' CLEAR FROM SIGNS TO BITUMINOUS TRAIL

NO	DATE	BY	CKD	APPR	REVISION

I HEREBY CERTIFY THAT THIS PLAN WAS PREPARED BY ME OR UNDER MY DIRECT SUPERVISION AND THAT I AM A DULY LICENSED PROFESSIONAL ENGINEER UNDER THE LAWS OF THE STATE OF MINNESOTA.  
 PRINT NAME: ANDREW WITTER  
 SIGNATURE: *Andrew Witter*  
 DATE: 3/13/13 LICENSE NO. 42757

DRAWN BY MTH DATE 2-10-13  
 DESIGN BY MTH DATE 2-10-13  
 CHECKED BY JR DATE 02-XX-12



ANOKA COUNTY  
 HIGHWAY DEPT.

STATE PROJECT NO. \_\_\_\_\_  
 STATE PROJECT NO. \_\_\_\_\_  
 STATE PROJECT NO. \_\_\_\_\_  
 COUNTY PROJECT NO. 13-16-28

SIGNING & STRIPING DETAILS  
 Sheet 22 of 25 Sheets

# MARKINGS FOR PEDESTRIAN CROSSWALKS

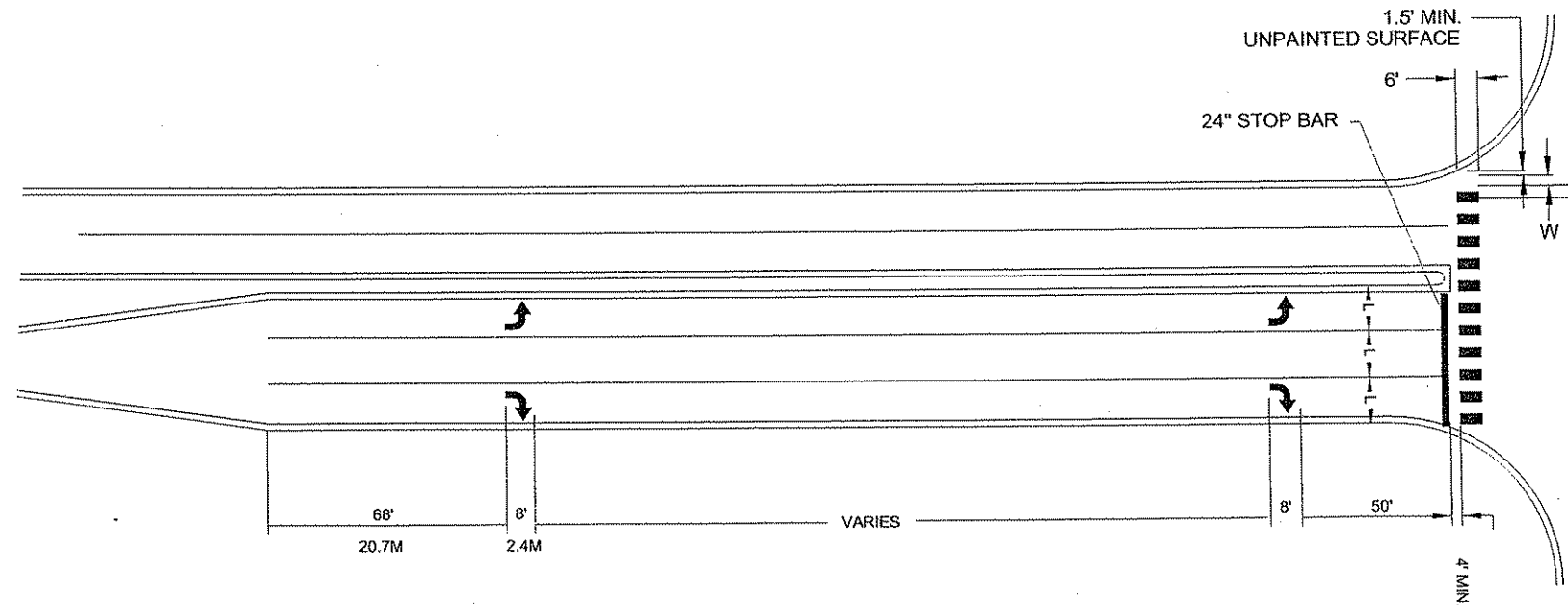

(L)	(W)	(S)
WIDTH OF INSIDE LANE	WIDTH OF PAINTED AREAS	WIDTH OF SPACE
9'	2.0'	2.5'
10'	2.5'	2.5'
11'	2.5'	3.0'
12'	3.0'	3.0'
13'	3.0'	3.5'

**NOTES: CROSSWALKS:**

- 1.) PAINTED AREAS ARE TO BE CENTERED ON CENTER AND LANE LINES, EVEN IF INTERSECTION IS NOT ALIGNED.
- 2.) LOCATION OF ZEBRA CROSSWALKS AND STOP BARS, SIGNAL LOOPS AND PED RAMPERS ARE APPROXIMATE. FINAL LOCATIONS ARE TO BE DETERMINED AND FIELD VERIFIED DURING CONSTRUCTION BY THE FIELD ENGR.
- 3.) ZEBRA CROSSWALKS ARE TO BE PARALLEL TO THE DRIVING LANE OR LANES, EVEN IF THE STREET IS ON AN ANGLE TO THE INTERSECTION.
- 4.) A MIN. OF 1.5' (450mm) CLEAR DISTANCE MUST BE LEFT ADJACENT TO THE CURB. IF LAST PAINTED AREA FALLS INTO THIS AREA, IT MUST BE OMITTED.
- 5.) ON TWO LANE STREETS, USE SPACING SHOWN FOR AN 11' (3.3m) INSIDE LANE.

NO	DATE	BY	OKD	APPR	REVISION

I HEREBY CERTIFY THAT THIS PLAN WAS PREPARED BY ME OR UNDER MY DIRECT SUPERVISION AND THAT I AM A DULY LICENSED PROFESSIONAL ENGINEER UNDER THE LAWS OF THE STATE OF MINNESOTA.

PRINT NAME: ANDREW MITTER  
 SIGNATURE: *[Signature]*  
 DATE: 3/13/13 LICENSE NO. 42757

DRAWN BY MTH DATE 2-10-13  
 DESIGN BY MTH DATE 2-10-13  
 CHECKED BY JR DATE 02-14-12

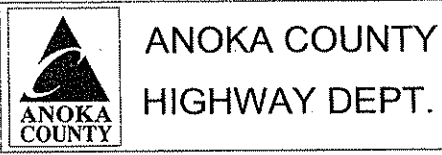

STATE PROJECT NO. \_\_\_\_\_  
 STATE PROJECT NO. \_\_\_\_\_  
 STATE PROJECT NO. \_\_\_\_\_  
 COUNTY PROJECT NO. 13-16-28

SIGNING & STRIPING DETAILS

Sheet 23 of 25 Sheets



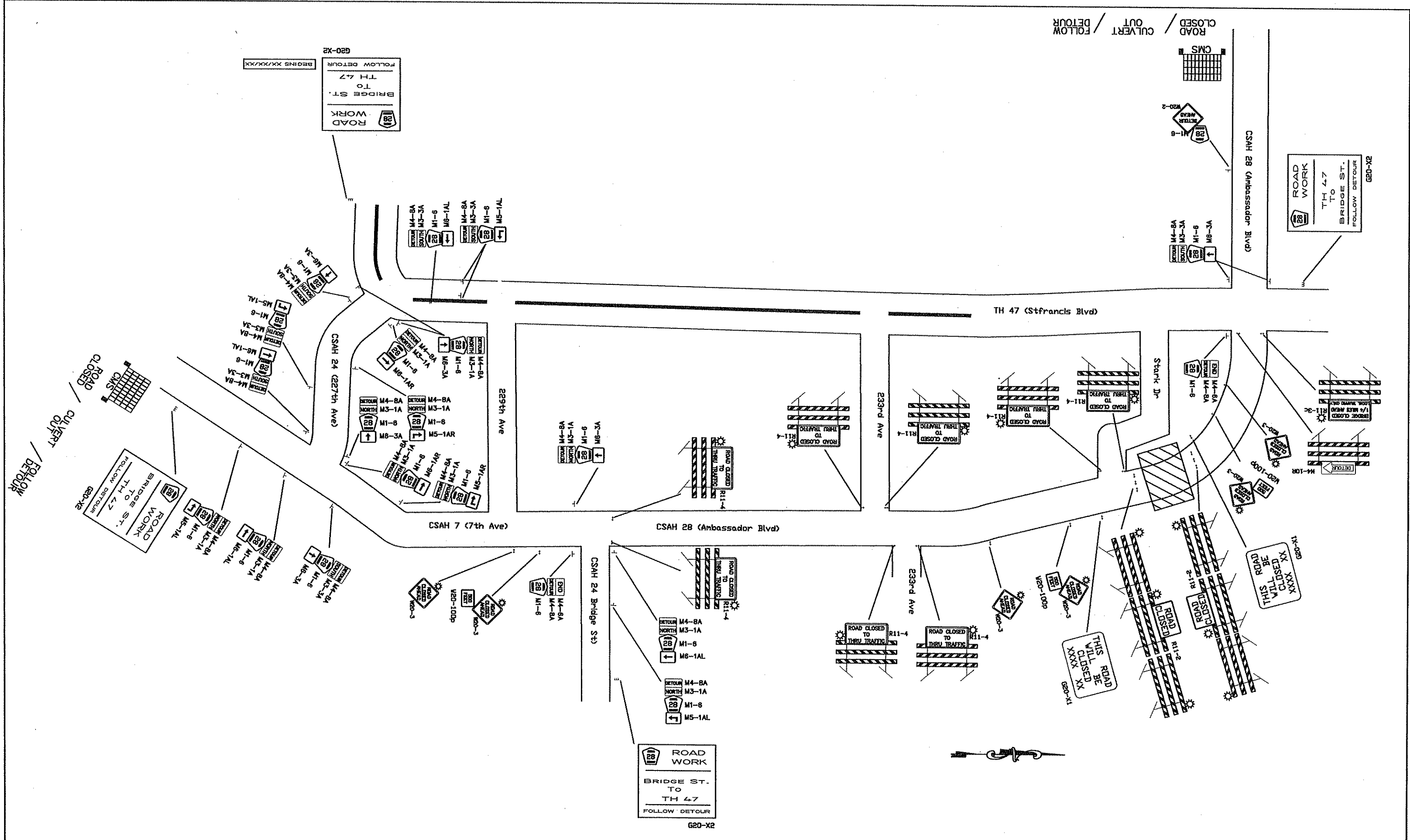

NO	DATE	BY	CHKD	APPR	REVISION
NAME: T:\Traffic\dwg\CSAH 14 (Main St)\RR DET 14.dwg					

I HEREBY CERTIFY THAT THIS PLAN WAS PREPARED BY ME OR UNDER MY DIRECT SUPERVISION AND THAT I AM A DULY LICENSED PROFESSIONAL ENGINEER UNDER THE LAWS OF THE STATE OF MINNESOTA.

PRINT NAME: ANDREW WITMER  
 SIGNATURE: *[Signature]*  
 DATE: 2/13/13 LICENSE NO. 42757

ROAD WORK  
 BRIDGE ST. TO TH 47  
 FOLLOW DETOUR  
 G20-X2

ANOKA COUNTY HIGHWAY DEPT.

DRAWN BY: RLB DATE: 01/29/13  
 DESIGN BY: RLB DATE: 01/29/13  
 CHECKED BY: JR DATE: 2/01/13



STATE PROJECT NO. \_\_\_\_\_  
 STATE AID PROJECT NO. \_\_\_\_\_  
 CITY PROJECT NO. \_\_\_\_\_  
 COUNTY PROJECT NO. 13-16-28

M.U.T.C.D. CODE	SIZE	INSERT	QTY.	M.U.T.C.D. CODE	SIZE	INSERT	QTY.
M4-8	24"x12"	M4-6 END	• 1	R11-4	60"x30"	ROAD CLOSED TO THRU TRAFFIC	• 4
M3-4A	24"x12"	M5-1AL	• 2	8 FT.	TYPE III		• 4
M1-6A	24"x24"	M5-1AR	• 2				
	21"x15"	M6-1AL	• 2	R11-4	60"x30"	ROAD CLOSED TO THRU TRAFFIC	• 4
		M6-1AR	• 2	8 FT.	TYPE III		• 4
		M6-3A	• 4				
M4-8	24"x12"	M4-6 END	• 1	R11-4	48"x18"	DETOUR	• 1
M3-4A	24"x12"	M5-1AL	• 3	8 FT.	TYPE III		• 1
M1-6A	24"x24"	M5-1AR	• 0				
	21"x15"	M6-1AL	• 2				
		M6-1AR	• 0				
		M6-3A	• 4				
G20-X2	132"x108"	ROAD WORK TH 47 TO BRIDGE ST. FOLLOW DETOUR	• 1	R11-4	48"x30"	ROAD CLOSED	• 2
		G20-X2		8 FT.	TYPE III		• 2
G20-X2	132"x108"	ROAD WORK BRIDGE ST. TO TH 47 FOLLOW DETOUR	• 3	R11-4	60"x30"	ROAD CLOSED 1/4 MILES AHEAD LOCAL TRAFFIC ONLY	• 1
		G20-X2		8 FT.	TYPE III		• 1
G20-X2	114"x20"	BEGINS XX/XX/XX	• 4	8 FT.	TYPE III		• 2
M1-6A	24"x24"	DETOUR AHEAD	• 1	8 FT.	TYPE III		• 2
W20-2	48"x48"	DETOUR AHEAD	• 1				
W20-3	48"x48"	ROAD CLOSED AHEAD	• 6	G20-X1	72"x 60"	THIS ROAD WILL BE CLOSED XXXX XX	• 2
W20-100p	24"x18"	FEET FEET	• 3				
THE NUMBER OF DAYS BE LIMITED FOR THE ROAD CLOSURE TO BE 8 DAYS MAXIMUM.			• 2				
CMS							

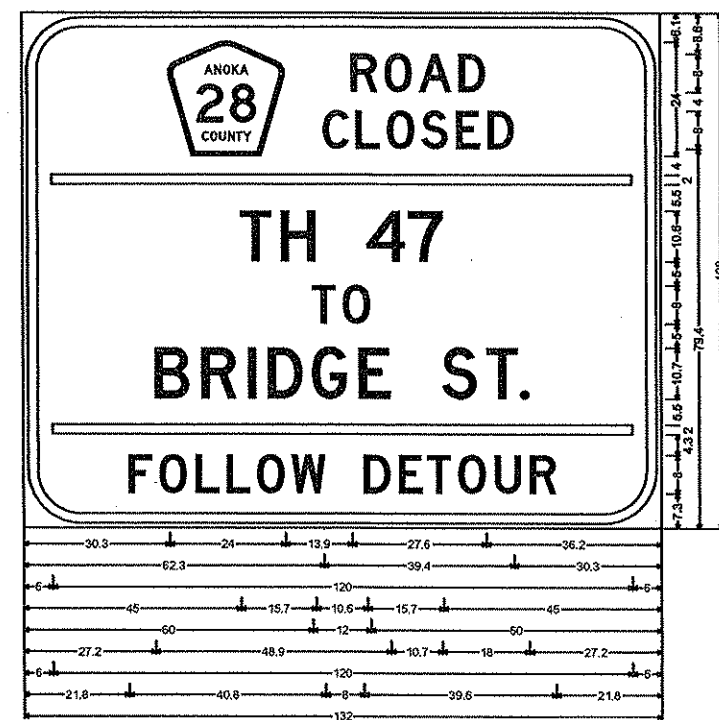
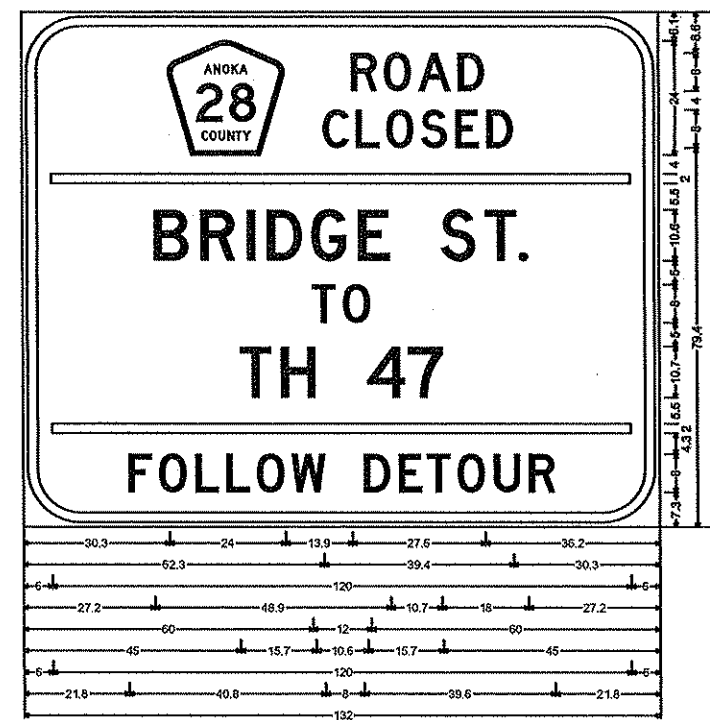

G20-X2\_132x108; 12.0" Radius, 2.0" Border, 1.0" Indent, Black on Orange; [ROAD] D; [CLOSED] D; [BRIDGE ST.] D; [TO] D; [TH 47] D; [FOLLOW] D; [DETOUR] D;

INSTALL G20-X2 SIGNS 7 DAYS PRIOR WITH "BEGIN/DATE" PLATE; REMOVE PLATE AT START DATE OF CONSTRUCTION SO SIGN READS "FOLLOW DETOUR".

G20-X1 SIGN TO BE INSTALLED A MINIMUM OF SEVEN DAYS PRIOR TO ACTUAL CLOSING DATE OF ROAD CLOSURE AND IMPLEMENTATION OF DETOUR SIGNING. SIGNS TO BE REMOVED AT TIME OF DETOUR INSTALLATION.

- STANDARD TRAFFIC CONTROL NOTES:
- 1) LOCATIONS OF ALL SIGNS ARE APPROXIMATE, EXACT LOCATIONS WILL BE DETERMINED IN THE FIELD BY THE ENGINEER.
  - 2) ALL BARRICADES AND SIGNS SHALL BE PROPERLY WEIGHTED WITH SANDBAGS.
  - 3) ALL BARRICADES SHALL HAVE REFLECTIVE MATERIAL ON BOTH SIDES.
  - 4) ALL BARRICADES MARKINGS SHALL BE SLANTED IN ACCORDANCE WITH THE MINNESOTA MANUAL OF UNIFORM TRAFFIC CONTROL DEVICES.
  - 5) ALL TRAFFIC CONTROL DEVICES SHALL CONFORM TO THE MOST RECENT EDITION OF THE MINNESOTA MANUAL ON UNIFORM TRAFFIC CONTROL DEVICES.
  - 6) ADDITIONS OR CHANGES TO THIS PLAN MAY BE MADE AS DETERMINED BY THE ENGINEER.

I HEREBY CERTIFY THAT THIS PLAN WAS PREPARED BY ME OR UNDER MY DIRECT SUPERVISION AND THAT I AM A DULY LICENSED PROFESSIONAL ENGINEER UNDER THE LAWS OF THE STATE OF MINNESOTA.					DRAWN BY: RLB DATE 02/04/13	ANOKA COUNTY HIGHWAY DEPT.	STATE PROJECT NO. _____	DETOUR
PRINT NAME: ANDREW WITTER					DESIGN BY: RLB DATE 02/04/13		STATE AID PROJECT NO. _____	
SIGNATURE: <i>[Signature]</i>					CHECKED BY: JR DATE 2/01/13	CITY PROJECT NO. _____	COUNTY PROJECT NO. 13-16-28	Sheet 25 of 25 Sheets
NO	DATE	BY	CKD	APPR	REVISION			

NAME: T:\Traffic\chp\CSAH 14 (Main St)\RR DET 14.dwg