

ANOKA COUNTY HIGHWAY RIGHT-OF-WAY PLAT NO. 6

County Highway Project No. SAP 02-618-09

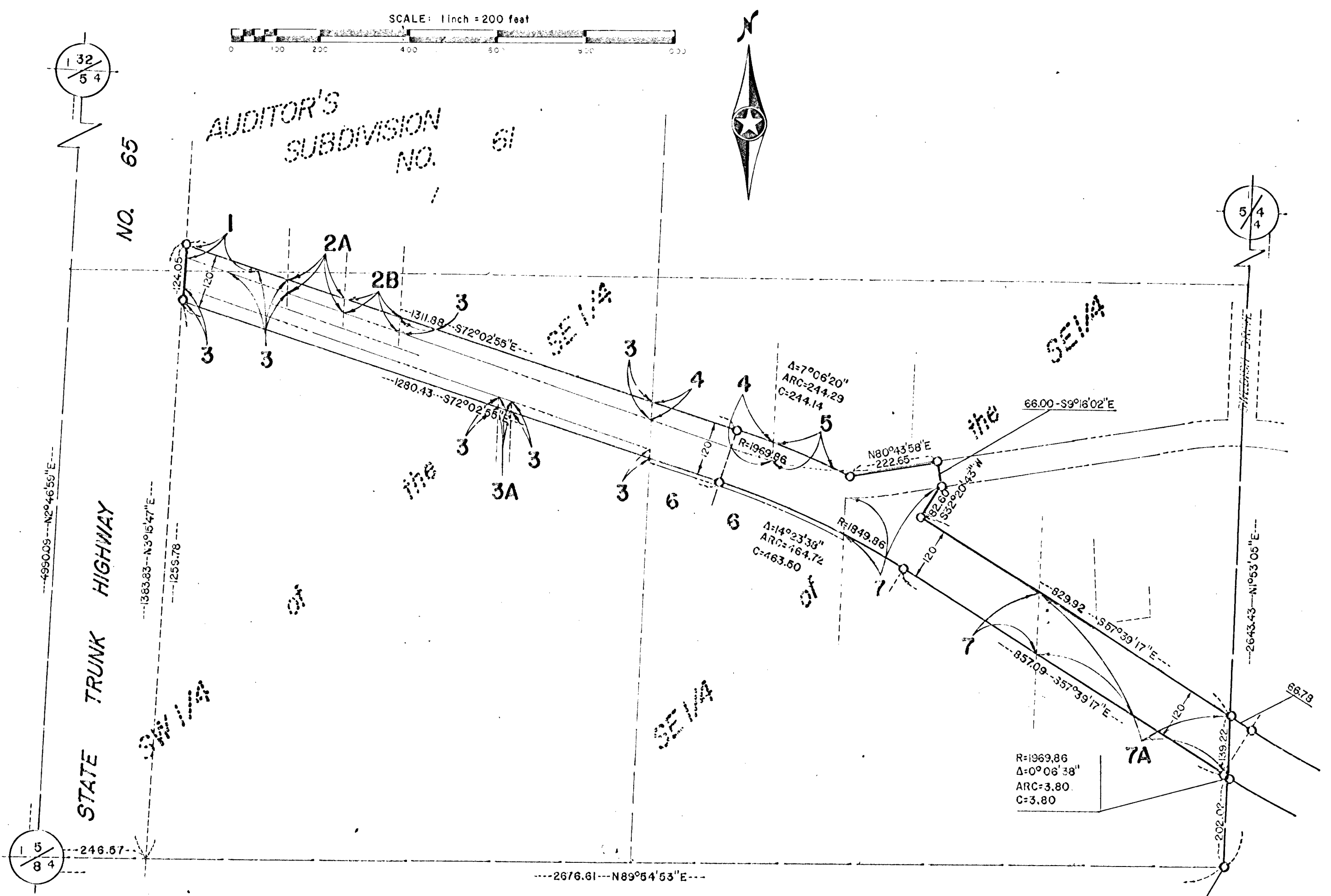

The Board of County Commissioners for Anoka County, Minnesota, pursuant to a Board Resolution dated June 25, 1974, is hereby designating the definite location of the Right of Way of County State Aid Highway No. 18, lying easterly of the easterly R/W line of U.S. Highway No. 65 and westerly of its intersection with County State Aid Highway No. 17 in the City of Ham Lake.

That portion of said highway located in the South Half of Section 5, the South Half of Section 4, the South Half of Section 3, the North Half of Section 9, the North Half of Section 10, the North Half of Section 11, and the Northwest Quarter of Section 12, all Township 32, Range 23, Anoka County, Minnesota as shown on this plat effected by the County of Anoka, Department of Highways, is hereby certified to be the official plat of that portion of said County State Aid Highway within said Sections pursuant to Minnesota Statutes 169.085.

Certified by: Paul K. Ruud Reg. No. 6549
Paul K. Ruud
County Highway Engineer

Date: Oct. 12, 1976

I hereby certify that this is a true and correct representation of a survey of the boundaries as shown, and that said survey was made under my direct supervision, that all distances are correctly shown in feet and decimals of a foot, that the monuments for the guidance of future surveys will be correctly placed in the ground as shown after completion of construction, and that there are no wetlands or public highways to be designated on said plat other than as shown thereon.

Roland W. Anderson Reg. No. 5715
Roland W. Anderson
County Surveyor

Date: Oct. 12, 1976

CONVENTIONAL SYMBOLS

- Section Line -----
- Quarter Line -----
- Sixteenth Line -----
- R/W Boundary Line -----
- Old R/W Boundary Line -----
- R/W Parcel No. 3
- Cast Iron R/W Monument -----○-----
- Property Line -----

PROCEDURAL STATEMENTS

1. The methods and equipment used in the control surveys for this plat and the checks made on monument location were accomplished with electronic measuring devices.
2. Certificates of location are on file in the Office of the County Surveyor for the section corner monuments shown on this plat.
3. For details of the control survey and land survey, contact the County Surveyor's Office for survey of R/W Plat No. 6, State Aid Project No. SAP 02-618-09.
4. Bearings shown are assumed.

PARCEL	OWNER	LOCATION	DEED RECORD		TORRENS CERTIFICATE NO.	ENTIRE TRACT acres	OTHER ROAD IN NEW R/W acres	NEW HIGHWAY RIGHT OF WAY acres	BALANCE OF TRACT REMAINING acres
			book	page					
1	Adolph Olson	Pt. Lot 1, Aud. Sub. No. 61	96	338		23.51		0.07	23.44
2A	Kenneth R. Wisen	Pt. SW 1/4, SE 1/4	932	287		0.44		0.09	0.35
2B	Kenneth R. Wisen	Pt. SW 1/4, SE 1/4	1017	150		0.51		0.09	0.42
3	Adolph Olson	Pt. SW 1/4, SE 1/4	84	382		29.33		1.20	28.13
4	Charles W. Litvarg	Pt. SE 1/4, SE 1/4	479	627		2.40		0.26	2.14
5	Paul Haensel	Pt. SE 1/4, SE 1/4	935	21		20.60		0.10	20.50
6	The City of Ham Lake	Pt. SE 1/4, SE 1/4	1121	289		8.65			8.65
7	Marie Soderquist and Al D. Soderquist	Pt. SE 1/4, SE 1/4	1096	155		12.99		1.42	11.57
7A	Marie Soderquist and Al P. Soderquist	Pt. SE 1/4, SE 1/4	307	473		5.00		1.42	3.58
3A	School District No. 42	Pt. SW 1/4, SE 1/4	161	24		0.17		0.01	0.16

JV
MV
TD

454811
1
2
3
4
5

ANOKA COUNTY HIGHWAY RIGHT-OF-WAY PLAT NO. 6

County Highway Project No. SAP 02-618-09

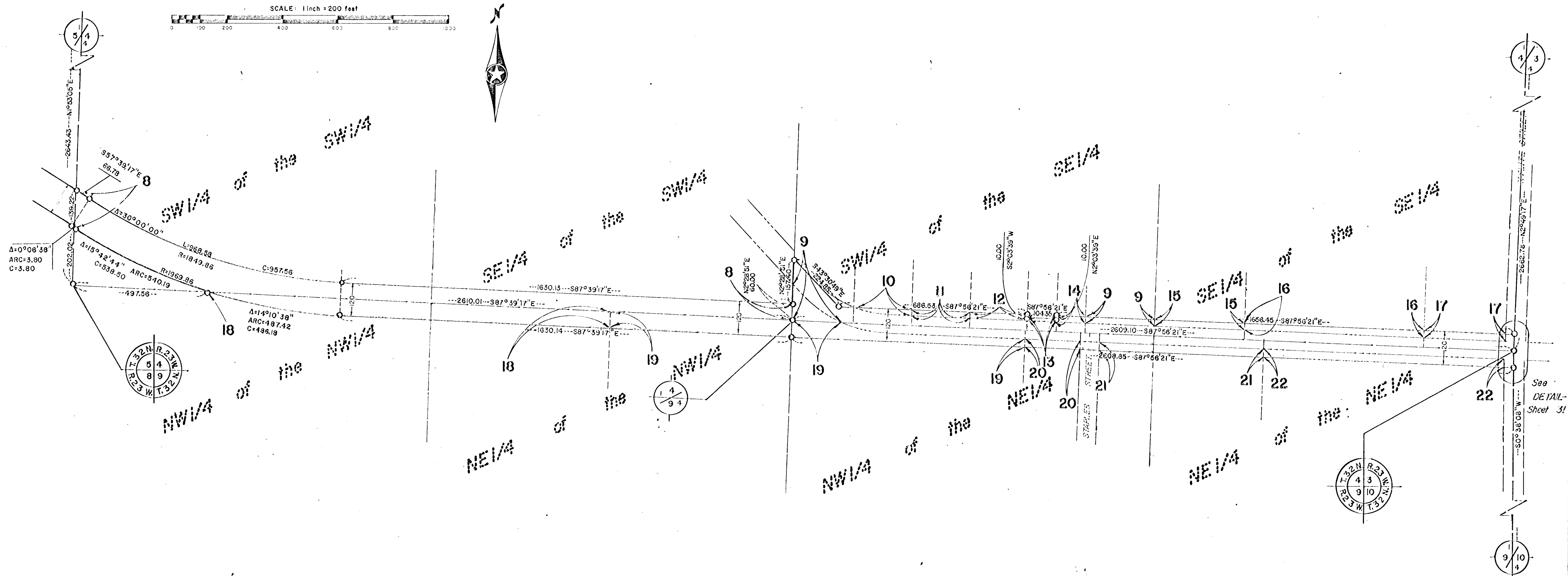

JV
MV

RIGHT OF WAY IN SECTION 4									
PARCEL	OWNER	LOCATION	DEED RECORD		TORRENS CERTIFICATE NO.	ENTIRE TRACT acres	OTHER ROAD IN NEW R/W acres	NEW HIGHWAY RIGHT OF WAY acres	BALANCE OF TRACT REMAINING acres
			book	page					
8	Cora Hanson, Oliver Johnson, and Vernon Johnson	Pt. S 1/2, SW 1/4	610	143		44.53		4.55	39.98
9	Adolph E. Anderson	Pt. SW 1/4, SE 1/4	610	147		34.00		0.38	33.62
10	Ducwyn W. Anderson	Pt. SW 1/4, SE 1/4	738	523		1.00		0.09	0.91
11	Sylvia M. L. Jacobson	Pt. SW 1/4, SE 1/4	538	67		1.00		0.10	0.90
12	Howard E. Magnuson	Pt. SW 1/4, SE 1/4	275	373		1.00		0.10	0.90
13	Walter P. Osborne, Jr.	Pt. SW 1/4, SE 1/4	632	277		0.50		0.02	0.48
14	Roald A. Beckensten	Pt. SW 1/4, SE 1/4	702	81		0.50		0.05	0.45
15	Eugene J. Kivi	Pt. SE 1/4, SE 1/4	1098	142		4.88		0.20	4.68
16	George Herda and Joseph Lambert	Pt. SE 1/4, SE 1/4	963	173		30.16		0.40	29.76
17	Ruth Gardner	Pt. SE 1/4, SE 1/4	1121	68		4.96		0.18	4.78

RIGHT OF WAY IN SECTION 9									
PARCEL	OWNER	LOCATION	DEED RECORD		TORRENS CERTIFICATE NO.	ENTIRE TRACT acres	OTHER ROAD IN NEW R/W acres	NEW HIGHWAY RIGHT OF WAY acres	BALANCE OF TRACT REMAINING acres
			book	page					
18	Edwin W. Magnuson	NW 1/4, NW 1/4 & N 1/2, NE 1/4, NW 1/4	207	317		60.00		1.80	58.20
19	Russell M. Wisen	E 1/2, NE 1/4, NW 1/4 & pt. NW 1/4, NE 1/4	207	316		52.90		1.66	51.24
20	Kenneth R. Wisen	Pt. NW 1/4, NE 1/4	983	436		1.35		0.12	1.23
21	Gerhard G. Larson	Pt. NW 1/4, NE 1/4 & pt. NE 1/4, NE 1/4	903	180		9.44		0.37	9.07
22	George Herda and Joseph Lambert	Pt. NE 1/4, NE 1/4	963	173		18.83		0.54	18.29

ANOKA COUNTY HIGHWAY RIGHT-OF-WAY PLAT NO. 6

County Highway Project No. SAP 02-618-09

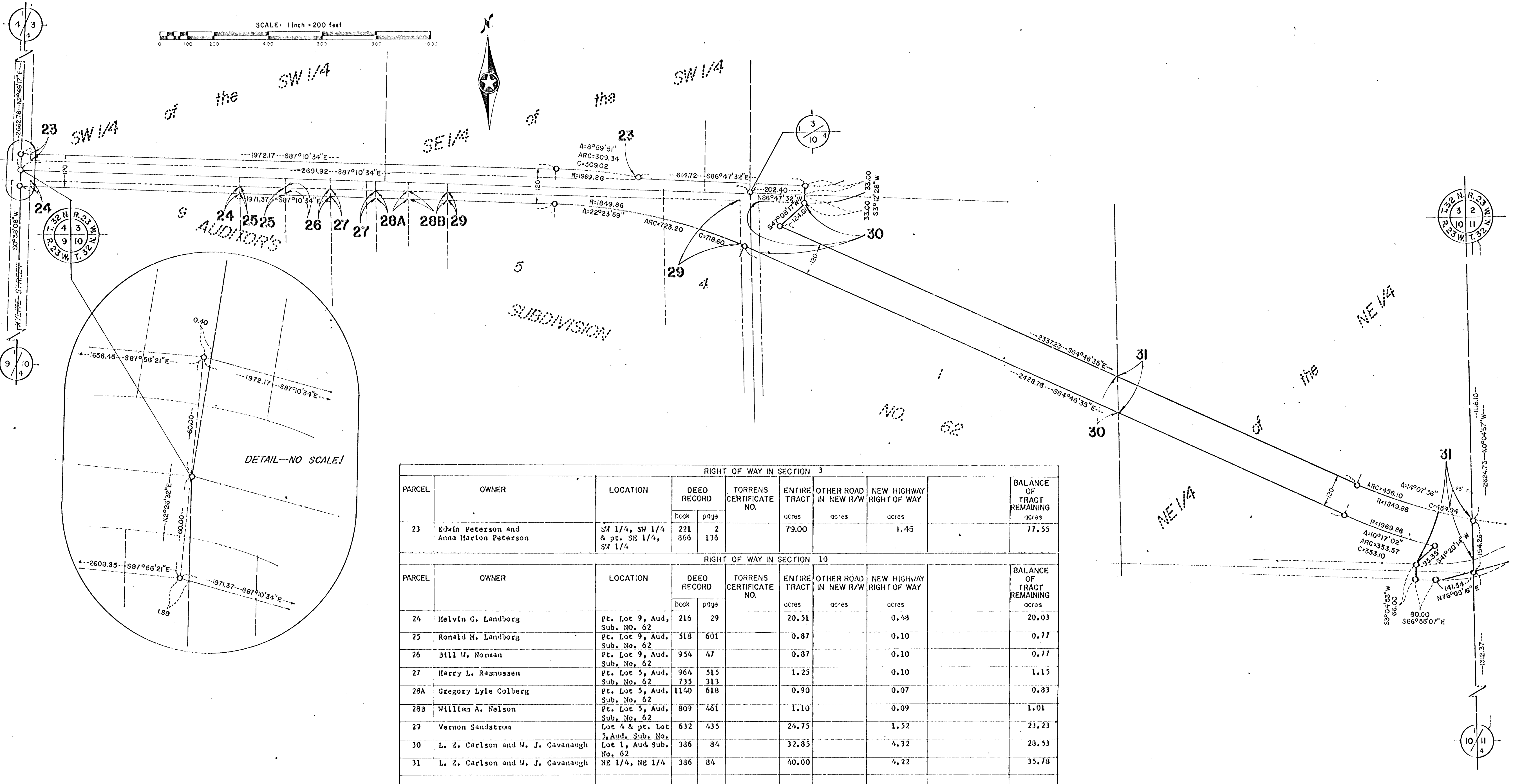

RIGHT OF WAY IN SECTION 3									
PARCEL	OWNER	LOCATION	DEED RECORD		TORRENS CERTIFICATE NO.	ENTIRE TRACT acres	OTHER ROAD IN NEW R/W acres	NEW HIGHWAY RIGHT OF WAY acres	BALANCE OF TRACT REMAINING acres
			book	page					
23	Edwin Peterson and Anna Marion Peterson	SW 1/4, SW 1/4 & pt. SE 1/4, SW 1/4	221	2		79.00		1.45	77.55
RIGHT OF WAY IN SECTION 10									
PARCEL	OWNER	LOCATION	DEED RECORD		TORRENS CERTIFICATE NO.	ENTIRE TRACT acres	OTHER ROAD IN NEW R/W acres	NEW HIGHWAY RIGHT OF WAY acres	BALANCE OF TRACT REMAINING acres
			book	page					
24	Helvin C. Landborg	Pt. Lot 9, Aud. Sub. No. 62	216	29		20.51		0.48	20.03
25	Ronald H. Landborg	Pt. Lot 9, Aud. Sub. No. 62	518	601		0.87		0.10	0.77
26	Bill W. Norman	Pt. Lot 9, Aud. Sub. No. 62	954	47		0.87		0.10	0.77
27	Harry L. Rasmussen	Pt. Lot 5, Aud. Sub. No. 62	964	515		1.25		0.10	1.15
28A	Gregory Lyle Colberg	Pt. Lot 5, Aud. Sub. No. 62	1140	618		0.90		0.07	0.83
28B	William A. Nelson	Pt. Lot 5, Aud. Sub. No. 62	809	461		1.10		0.09	1.01
29	Vernon Sandstrom	Lot 4 & pt. Lot 5, Aud. Sub. No. 62	632	435		24.75		1.52	23.23
30	L. Z. Carlson and W. J. Cavanaugh	Lot 1, Aud. Sub. No. 62	386	84		32.85		4.32	28.53
31	L. Z. Carlson and W. J. Cavanaugh	NE 1/4, NE 1/4	386	84		40.00		4.22	35.78

MU
JU
TD

ANOKA COUNTY HIGHWAY RIGHT-OF-WAY PLAT NO. 6

County Highway Project No. SAP 02-618-09

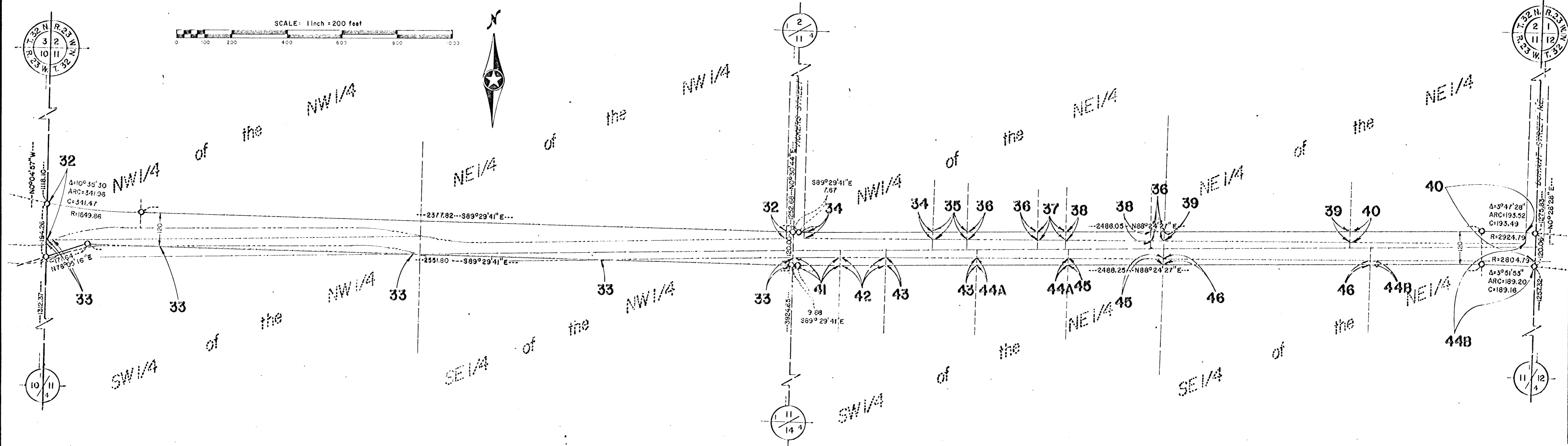

RIGHT OF WAY IN SECTION 11

PARCEL	OWNER	LOCATION	DEED RECORD		TORRENS CERTIFICATE NO.	ENTIRE TRACT acres	OTHER ROAD IN NEW R/W acres	NEW HIGHWAY RIGHT OF WAY acres	BALANCE OF TRACT REMAINING acres
			book	page					
32	Walter Ehrenreiter	Pt. N 1/2, NW 1/4	451	467		77.01		3.28	73.73
33	Mary E. Bauer	S 1/2, NW 1/4 & pt. NW 1/4, NW 1/4	235	53		82.00		0.48	81.52
34	LeRoy A. Nelson	Pt. NW 1/4, NE 1/4	1080	499		5.90		0.29	6.61
35	Hillard L. Koop	Pt. NW 1/4, NE 1/4	988	310		0.72		0.08	0.64
36	Leonard A. Kunshire	Pt. NW 1/4, NE 1/4	207	1		16.49		0.16	16.33
37	Leonard A. Kunshire	Pt. NW 1/4, NE 1/4	207	1		0.57		0.06	0.51
38	George J. Gaze	Pt. NW 1/4, NE 1/4	1108	464		1.77		0.19	1.58
39	Carl Larsen, Jr.	W 1/2, NE 1/4, NE 1/4	654	29		20.00		0.54	19.46
40	Oscar L. Nazann	Pt. E 1/2, NE 1/4, NE 1/4	650	455		15.00		0.52	14.48
41	John J. Huttner, Jr.	Pt. SW 1/4, NE 1/4	864	291		5.00		0.10	4.90
42	Joseph S. Wicklund	Pt. SW 1/4, NE 1/4	717	507		10.00		0.10	9.90
43	Harry Matheson	Pt. SW 1/4, NE 1/4	220	276		4.00		0.20	3.80
44	Harry Matheson	Pt. SW 1/4, NE 1/4 & pt. SE 1/4, NE 1/4	220	276		28.00		0.48	27.52
45	Harry Matheson	Pt. SW 1/4, NE 1/4	220	276		11.00		0.21	10.79
46	Harry Matheson	Pt. SE 1/4, NE 1/4	220	276		20.00		0.35	19.65

JV
MV
70

ANOKA COUNTY HIGHWAY RIGHT-OF-WAY PLAT NO. 6

County Highway Project No. SAP 02-618-09

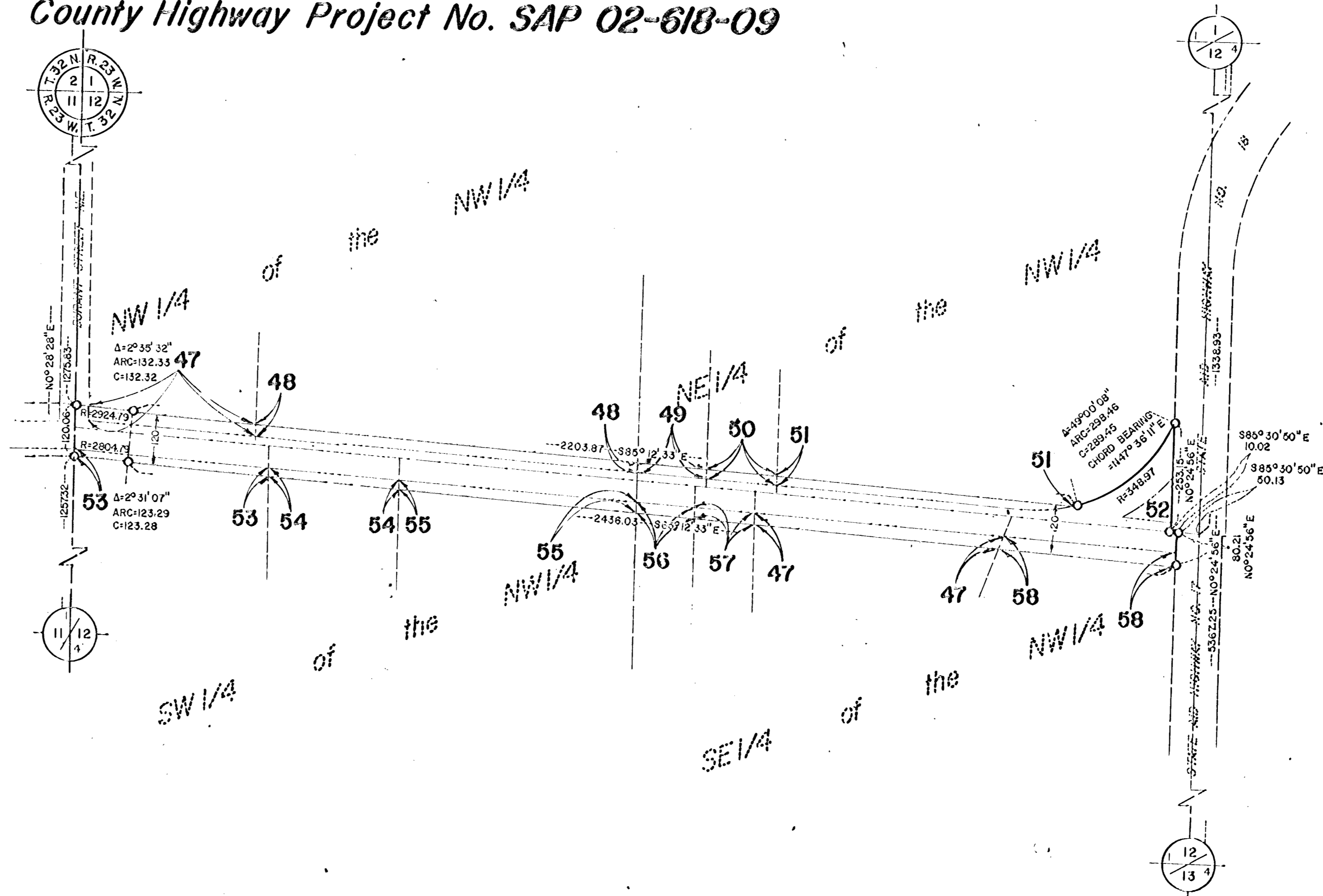
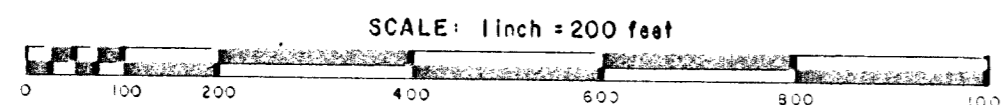

TO
JU
MV

PARCEL	OWNER	LOCATION	DEED RECORD		TORRENS CERTIFICATE NO.	ENTIRE TRACT acres	OTHER ROAD IN NEW R/W acres	NEW HIGHWAY RIGHT OF WAY acres	BALANCE OF TRACT REMAINING acres
			book	page					
47	Ed Fields and Sons, Inc.	Pt. NW 1/4, NW 1/4 & pt. SE 1/4, NW 1/4	780	267		47.80		0.63	47.17
			783	339					
48	Dennis L. Welcose	Pt. NW 1/4, NW 1/4	1121	72		10.00		0.55	9.45
49	Leonard H. Sandstrom	W 1/2, W 1/4, NE 1/4, NW 1/4	381	415		5.00		0.10	4.90
50	David Leo Sandstrom	E 1/2, W 1/4, NE 1/4, NW 1/4	839	493		5.00		0.10	4.90
51	Clinton M. Hallberg	Pt. NE 1/4, NW 1/4	601	410		18.61		0.32	18.29
52	Leonard H. Sandstrom	Pt. NE 1/4, NW 1/4	415	150		0.59		0.13	0.37
53	Fred E. Olson	Pt. SW 1/4, NW 1/4	454	315		14.59		0.28	13.31
54	Raymond E. Olson	Pt. SW 1/4, NW 1/4	1042	458		9.00		0.18	8.82
55	Dawn A. Anderson	Pt. SW 1/4, NW 1/4	456	381		16.41		0.34	16.07
56	Michael Eugene Axend	Pt. SE 1/4, NW 1/4	1111	570		1.00		0.08	0.92
57	Royce D. Zoudke & Deborah Zoudke	Pt. SE 1/4, NW 1/4	1156	237		1.08		0.08	1.00
58	Wilbur J. Matheson	Pt. SE 1/4, NW 1/4	244	277		2.00		0.28	1.72