

Date : 8/22/96 AM 8/20/96 PM

Count Number : TMC 9625

Location : CSAH 1 (Coon Rapids Blvd) @

Avocet St.

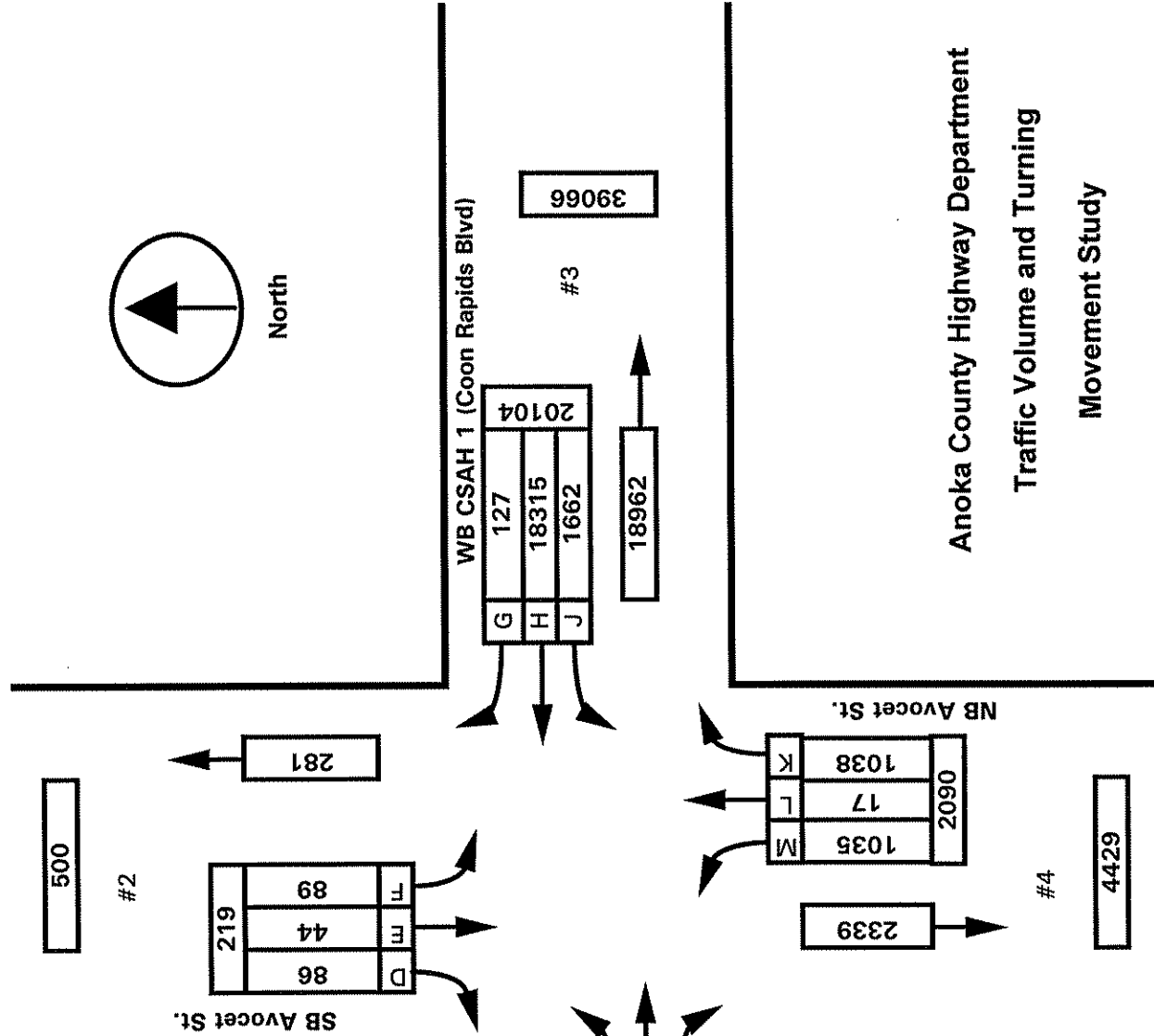

Anoka County Highway Department
Traffic Volume and Turning
Movement Study

	LANES OF APPROACH			TOTAL
	RIGHT TURN LANE	LEFT TURN LANE	THRU LANES	
#1	1	1	2	4
#2	0	0	1	1
#3	1	1	3	5
#4	1	1	1	3

ANOKA COUNTY HIGHWAY DEPARTMENT

TRAFFIC ENGINEERING SECTION

TRAFFIC STUDY

Weather :sunny 85
 Counted by:Ann and Gabe
 Ward # :
 Other :

Study Name: TMC9625
 Site Code : 96250202
 Start Date: 08/20/96
 Page : 1

Vehicle group 1

Start Time	Avocet St. From North				CSAH 1 (Coon Rapids Bl) From East				Avocet St. From South				CSAH 1 (Coon Rapids Bl) From West				Intvl	Exclu	Inclu
	Right	Thru	Left	HEAVY	Right	Thru	Left	HEAVY	Right	Thru	Left	HEAVY	Right	Thru	Left	HEAVY			
08/20/96																			
06:00	0	0	0	0	0	35	3	2	5	0	1	1	0	435	0	3	485	6	479
06:15	0	0	0	0	0	79	3	1	13	0	3	2	7	588	0	2	698	5	693
06:30	0	0	0	0	0	97	8	5	16	0	3	3	5	709	0	6	852	14	838
06:45	0	0	0	0	0	115	13	3	13	0	5	3	4	707	0	8	871	14	857
Hour	0	0	0	0	0	326	27	11	47	0	12	9	16	2439	0	19	2906	39	2867
07:00	0	0	1	0	1	74	8	4	19	0	8	2	4	683	1	10	815	16	799
07:15	0	0	1	0	0	154	9	7	32	0	3	2	4	721	0	6	939	15	924
07:30	0	0	2	0	1	146	10	3	56	0	7	4	3	698	0	6	936	13	923
07:45	0	0	0	0	0	154	9	6	17	0	6	1	13	709	0	6	921	13	908
Hour	0	0	4	0	2	528	36	20	124	0	24	9	24	2811	1	28	3611	57	3554
08:00	1	0	1	0	2	154	5	5	14	0	14	2	6	419	0	9	632	16	616
08:15	0	0	0	0	2	135	9	13	13	0	6	0	17	346	0	6	547	19	528
08:30	1	0	1	0	1	140	7	12	12	0	8	0	6	300	3	4	495	16	479
08:45	0	0	0	0	0	145	14	11	16	0	12	3	9	260	0	6	476	20	456
Hour	2	0	2	0	5	574	35	41	55	0	40	5	38	1325	3	25	2150	71	2079
09:00	1	0	0	0	1	144	18	10	14	0	7	2	8	199	2	9	415	21	394
09:15	1	0	0	0	2	134	12	5	11	0	10	1	13	227	0	4	420	10	410
09:30	0	1	1	0	1	143	17	15	16	0	9	1	4	226	2	9	445	25	420
09:45	0	0	1	0	0	155	18	11	12	0	12	1	14	210	1	6	441	18	423
Hour	2	1	2	0	4	576	65	41	53	0	38	5	39	862	5	28	1721	74	1647
10:00	1	0	1	0	1	145	17	9	20	0	15	2	13	241	0	7	472	18	454
10:15	1	0	0	0	1	163	18	11	17	1	10	1	9	208	1	1	442	13	429
10:30	0	0	3	0	2	149	21	7	17	0	20	1	11	209	1	8	449	16	433
10:45	0	2	0	0	1	163	18	7	8	1	14	3	9	224	1	5	456	15	441
Hour	2	2	4	0	5	620	74	34	62	2	59	7	42	882	3	21	1819	62	1757
11:00	0	0	1	0	1	196	23	13	16	0	15	0	14	232	2	7	520	20	500
11:15	1	0	0	0	3	212	17	6	19	0	23	0	15	212	0	13	521	19	502
11:30	3	1	2	0	2	178	18	6	18	0	24	1	12	172	0	5	442	12	430
11:45	2	1	1	0	3	190	31	6	17	0	20	1	10	240	0	8	530	15	515
Hour	6	2	4	0	9	776	89	31	70	0	82	2	51	856	2	33	2013	66	1947
12:00	4	0	0	0	2	221	29	15	19	0	21	3	11	217	2	6	550	24	526
12:15	1	1	0	0	3	211	30	10	14	0	25	1	9	237	1	6	549	17	532
12:30	1	0	2	0	1	231	29	5	20	0	27	3	15	248	0	6	588	14	574
12:45	0	1	0	0	1	240	22	11	22	0	30	3	19	243	0	12	604	26	578
Hour	6	2	2	0	7	903	110	41	75	0	103	10	54	945	3	30	2291	81	2210

ANOKA COUNTY HIGHWAY DEPARTMENT

Weather :sunny 85
 Counted by:Ann and Gabe
 Ward # :
 Other :

TRAFFIC ENGINEERING SECTION
 TRAFFIC STUDY

Study Name: TMC9625
 Site Code : 96250202
 Start Date: 08/20/96
 Page : 2

Vehicle group 1

Start Time	Avocet St. From North				CSAH 1 (Coon Rapids Bl) From East				Avocet St. From South				CSAH 1 (Coon Rapids Bl) From West				Intvl	Exclu	Inclu
	Right	Thru	Left	HEAVY	Right	Thru	Left	HEAVY	Right	Thru	Left	HEAVY	Right	Thru	Left	HEAVY			
13:00	1	0	0	0	1	241	32	12	21	0	25	4	20	249	2	11	619	27	592
13:15	0	0	0	0	0	232	25	8	23	0	18	1	8	251	1	12	579	21	558
13:30	0	0	1	0	3	246	29	11	10	0	22	2	20	272	0	6	622	19	603
13:45	0	0	3	0	2	242	43	7	23	0	24	2	16	251	2	4	619	13	606
Hour	1	0	4	0	6	961	129	38	77	0	89	9	64	1023	5	33	2439	80	2359
14:00	0	3	2	0	1	252	35	9	23	0	21	2	14	227	5	7	601	18	583
14:15	1	0	5	1	1	303	30	7	17	1	24	0	21	263	4	6	684	14	670
14:30	0	1	4	1	0	330	43	7	21	2	16	1	14	251	1	8	700	17	683
14:45	1	1	3	0	2	393	37	14	26	1	25	2	13	221	0	11	750	27	723
Hour	2	5	14	2	4	1278	145	37	87	4	86	5	62	962	10	32	2735	76	2659
15:00	2	0	1	0	1	356	41	14	39	0	34	4	9	216	4	7	728	25	703
15:15	0	0	2	0	0	413	31	11	16	0	24	1	18	243	1	8	768	20	748
15:30	4	1	0	1	1	490	44	6	19	2	21	2	13	225	4	7	840	16	824
15:45	2	0	0	0	2	559	52	11	12	0	22	1	9	259	0	6	935	18	917
Hour	8	1	3	1	4	1818	168	42	86	2	101	8	49	943	9	28	3271	79	3192
16:00	0	2	5	0	0	579	38	9	14	0	28	0	12	243	3	9	942	18	924
16:15	1	2	1	0	2	694	29	17	13	0	15	0	6	206	0	2	988	19	969
16:30	0	0	1	0	0	695	59	4	14	0	22	2	7	242	4	5	1055	11	1044
16:45	0	0	1	0	3	748	48	7	21	0	29	1	10	205	2	2	1077	10	1067
Hour	1	4	8	0	5	2716	174	37	62	0	94	3	35	896	9	18	4062	58	4004
17:00	0	6	5	0	9	743	63	4	15	0	22	3	9	226	5	8	1118	15	1103
17:15	3	3	1	0	9	721	70	5	18	3	16	1	10	266	8	2	1136	8	1128
17:30	4	3	3	0	7	722	55	8	13	0	20	2	12	214	12	1	1076	11	1065
17:45	4	1	3	0	8	610	51	9	13	0	17	3	18	246	19	6	1008	18	990
Hour	11	13	12	0	33	2796	239	26	59	3	75	9	49	952	44	17	4338	52	4286
18:00	0	2	2	0	3	554	40	6	16	2	19	1	7	236	4	2	894	9	885
18:15	4	0	1	0	2	422	26	5	6	0	16	0	11	242	6	2	743	7	736
18:30	3	1	0	0	3	344	38	1	16	1	12	1	12	245	3	2	682	4	678
18:45	2	1	0	0	2	341	36	5	16	0	17	0	6	181	8	3	618	8	610
Hour	9	4	3	0	10	1661	140	17	54	3	64	2	36	904	21	9	2937	28	2909
19:00	11	0	4	0	7	280	25	5	15	0	9	0	13	227	4	2	602	7	595
19:15	4	2	2	0	3	300	18	1	20	2	14	0	6	172	4	2	550	3	547
19:30	3	1	2	0	2	238	18	3	14	0	19	0	6	196	5	3	510	6	504
19:45	0	0	4	0	7	249	17	2	19	1	23	1	1	154	2	0	480	3	477
Hour	18	3	12	0	19	1067	78	11	68	3	65	1	26	749	15	7	2142	19	2123

ANOKA COUNTY HIGHWAY DEPARTMENT

TRAFFIC ENGINEERING SECTION

TRAFFIC STUDY

Weather :sunny 85
 Counted by:Ann and Gabe
 Ward # :
 Other :

Study Name: TMC9625
 Site Code : 96250202
 Start Date: 08/20/96
 Page : 3

Vehicle group 1

Start Time	Avocet St. From North				CSAH 1 (Coon Rapids Bl) From East				Avocet St. From South				CSAH 1 (Coon Rapids Bl) From West				Intvl	Exclu	Inclu
	Right	Thru	Left	HEAVY	Right	Thru	Left	HEAVY	Right	Thru	Left	HEAVY	Right	Thru	Left	HEAVY			
20:00	1	1	2	0	0	227	22	1	6	0	18	0	13	165	2	0	458	1	457
20:15	12	0	2	0	2	241	16	1	8	0	11	0	6	159	1	1	460	2	458
20:30	3	0	1	0	3	256	18	2	11	0	18	1	7	171	1	2	494	5	489
20:45	1	0	1	0	1	213	28	2	7	0	10	0	2	161	1	1	428	3	425
Hour	17	1	6	0	6	937	84	6	32	0	57	1	28	656	5	4	1840	11	1829
21:00	0	0	5	0	1	235	19	1	6	0	19	0	5	187	0	0	478	1	477
21:15	1	1	2	0	1	193	17	0	5	0	16	0	4	166	2	0	408	0	408
21:30	0	1	1	0	1	198	14	3	6	0	5	1	2	140	0	0	372	4	368
21:45	0	4	1	0	5	152	19	1	10	0	6	0	9	137	0	3	347	4	343
Hour	1	6	9	0	8	778	69	5	27	0	46	1	20	630	2	3	1605	9	1596
Total	86	44	89	3	127	18315	1662	438	1038	17	1035	86	633	17835	137	335	41880	862	41018
% Apr.	38.7	19.8	40.0	1.3	0.6	89.1	8.0	2.1	47.7	0.7	47.5	3.9	3.3	94.1	0.7	1.7	-	-	-
% Int.	0.2	0.1	0.2	-	0.3	43.7	3.9	1.0	2.4	-	2.4	0.2	1.5	42.5	0.3	0.7	-	-	-

>r Street Approaches:

Eastbound:

CSAH 1 (Coon Rapids Blvd)
 Data File: C:\PETRA2\DATAFILE\TMC9625.PDF
 Count Type: IMC. Channel: 0. Count Date: 8/20/96
 Number of Lanes: 2
 Approach Speed: 45
 Total Approach Traffic: 18605

Westbound:

CSAH 1 (Coon Rapids Blvd)
 Data File: C:\PETRA2\DATAFILE\TMC9625.PDF
 Count Type: IMC. Channel: 0. Count Date: 8/20/96
 Number of Lanes: 2
 Approach Speed: 45
 Total Approach Traffic: 20104

Minor Street Approaches:

Northbound:

Avocet St.
 Data File: C:\PETRA2\DATAFILE\TMC9625.PDF
 Count Type: IMC. Channel: 0. Count Date: 8/20/96
 Number of Lanes: 2
 Approach Speed: 30
 Total Approach Traffic: 2090

Southbound:

Avocet St.
 Data File: C:\PETRA2\DATAFILE\TMC9625.PDF
 Count Type: IMC. Channel: 0. Count Date: 8/20/96
 Number of Lanes: 1
 Approach Speed: 30
 Total Approach Traffic: 219

Analysis of 8-Hour Volume Warrants (Criteria refers to high volume side street for that hour):

Hour	Main	Side	Rank	Warrant 1	Warrant 2	Warrant 8
Begin	(Total)	Vol.	Dir.	Meets? Criteria	Meets? Criteria	Meets? Criteria
0	0	0	S	17	105	52 84
1	0	0	S	18	105	52 84
2	0	0	S	19	105	52 84
3	0	0	S	20	105	52 84
4	0	0	S	21	105	52 84
5	0	0	S	22	105	52 84
6	2808	59	N	16	MAIN 140	MAIN 70 112
7	3402	148	N	7	--BOTH-- 140	--BOTH-- 70 112
8	1980	95	N	12	MAIN 140	--BOTH-- 70 112
9	1551	91	N	13	MAIN 140	--BOTH-- 70 112
10	1626	123	N	10	MAIN 140	--BOTH-- 70 112
11	1783	152	N	6	--BOTH-- 140	--BOTH-- 70 112
12	2022	178	N	2	--BOTH-- 140	--BOTH-- 70 112
13	2188	166	N	4	--BOTH-- 140	--BOTH-- 70 112
14	2461	177	N	3	--BOTH-- 140	--BOTH-- 70 112
15	2991	189	N	1	--BOTH-- 140	--BOTH-- 70 112
16	3835	156	N	5	--BOTH-- 140	--BOTH-- 70 112
17	4113	137	N	8	MAIN 140	--BOTH-- 70 112
18	2772	121	N	11	MAIN 140	--BOTH-- 70 112
19	1954	136	N	9	MAIN 140	--BOTH-- 70 112
20	1716	89	N	14	MAIN 140	--BOTH-- 70 112
21	1507	73	N	15	MAIN 140	--BOTH-- 70 112
22	0	0	S	23	105	52 84
23	0	0	S	24	105	52 84

Warrant Summary:

Rural values apply.

Warrant 1 - Minimum Vehicular Volumes

NOT SATISFIED. Required values reached for 7 hours. Criteria--Main St.: 420; Side St.: See Volume Summary.

Warrant 2 - Interruption of Continuous Traffic

SATISFIED for 15 hours. Criteria--Main St.: 630; Side St.: See Volume Summary.

Warrant 3 - Minimum Pedestrian Volumes

NOT SATISFIED. Ped volumes too low. Criteria--190 Peds in peak hour, 100 peds in 4th high hour.

Warrant 4 - School Crossing

NOT APPLICABLE. Gap data has not been defined.

Warrant 5 - Progressive Movement

NOT SATISFIED. Adjacent signals closer than 1000 feet and/or not part of coordinated system.

Warrant 6 - Accident Experience

NOT SATISFIED. 0 correctable accidents is fewer than required 5.

Correctable Accidents: 0; Right Angle Accidents: 0; Left Turn Accidents: 0; Other Accidents: 0.

Warrant 7 - Systems Warrant

NOT SATISFIED. At least one street has no major approaches. Peak hour total entering volume: 4286.

- Approaches which are part of the principal through traffic roadway network.
- Approaches which include rural or suburban highways outside, entering or traversing a city.
- Approaches which appear as a major route in an official transportation plan.

Warrant 8 - Combination of Warrants

SATISFIED for 11 hours. Criteria--Main: 504; Side: See Volume Summary.

Warrant 9 - Four Hour Volumes

SATISFIED for 14 hours.

Warrant 10 - Peak Hour Delay

NOT SATISFIED. Peak hour (1700 hours) volume not adequate.

Criteria--Main St.: 800 (4 approaches), 650 (3 approaches); Side St.: 150.

Warrant 11 - Peak Hour Volume

SATISFIED for 11 hours.

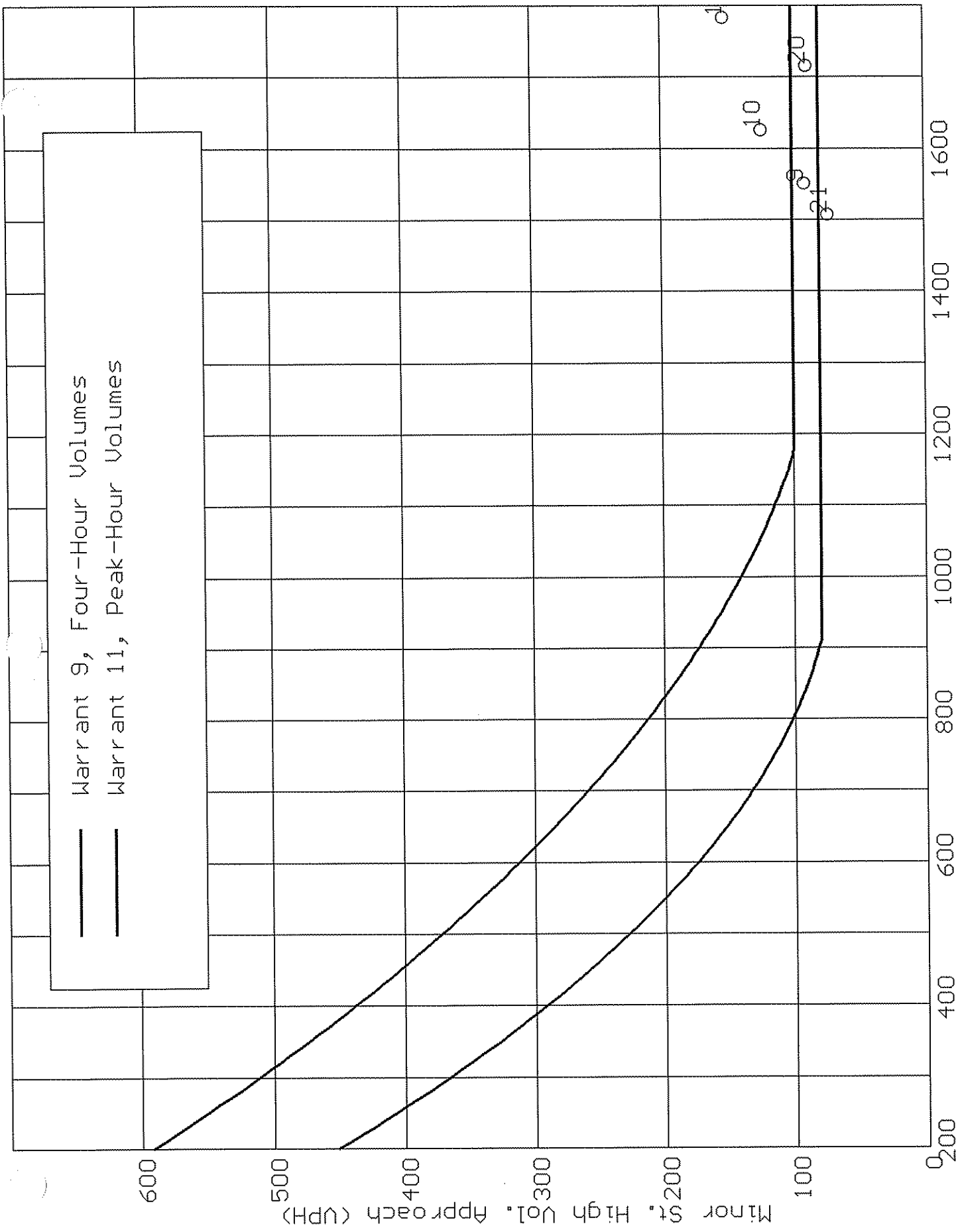

Major St. Total of Both Approaches (UPH)

↑
NORTH

APP. #1= EB CSAH 1

APP. #2 = SB Avocet St.

APP. #3= WB CSAH 1

APP. #4= NB Avocet St.

COUNT LOCATION: CSAH 1 (Coon Rapids Blvd) @
Avocet St.

DATE: 8/22/96

APP. #2 30 MPH	APP. #3 45 MPH
APP. #1 45 MPH	APP. #4 30 MPH

- HEAVY VEHICLE- ANY VEHICLE HAVING MORE THAN FOUR TIRES TOUCHING THE PAVEMENT
- A. TRUCKS- A HEAVY VEHICLE INVOLVED PRIMARILY IN THE TRANSPORT OF GOODS OR IN THE DELIVERY OF A SERVICE.
 - B. RV- A HEAVY VEHICLE OPERATED BY A PRIVATE MOTORIST AND INVOLVED IN THE TRANSPORT OF RECREATIONAL EQUIPMENT OR FACILITIES.
 - C. BUSES- A HEAVY VEHICLE INVOLVED IN THE TRANSPORTATION OF GROUPS OF PEOPLE.

TIME	PEDESTRIANS					HEAVY VEHICLES		
	APP. #1	APP. #2	APP. #3	APP. #4	15 MIN TOT	TRUCKS	RV	BUS
6:00-6:15AM	1				1	4		2
6:15-6:30						2		3
6:30-6:45						9		5
6:45-7:00	1	1			2	10	1	3
HOURLY TOTAL					3	HOURLY TOTAL		39
7:00-7:15	2				2	13		3
7:15-7:30						11		4
7:30-7:45						9		4
7:45-8:00						10		3
HOURLY TOTAL					2	HOURLY TOTAL		57
8:00-8:15						13		3
8:15-8:30						15	1	3
8:30-8:45	2	2			4	15		1
8:45-9:00						17		3
HOURLY TOTAL					4	HOURLY TOTAL		71
9:00-9:15						19		2
9:15-9:30						10		
9:30-9:45	2	2			4	21		4
9:45-10:00		1			1	15	1	2
HOURLY TOTAL					5	HOURLY TOTAL		74
10:00-10:15						16		2
10:15-10:30	1			1	2	13		
10:30-10:45	3	1			4	12		4
10:45-11:00						13		2
HOURLY TOTAL					6	HOURLY TOTAL		62
11:00-11:15	2	2			4	17		3
11:15-11:30						17		2
11:30-11:45						11	1	
11:45-12:00						13		2
HOURLY TOTAL					4	HOURLY TOTAL		66
12:00-12:15						19	1	4
12:15-12:30	1	2			3	16		1
12:30-12:45						13		1
12:45-1:00	5	5			10	23	1	2
HOURLY TOTAL					13	HOURLY TOTAL		81
1:00-1:15	7	7			14	24	1	2
1:15-1:30						17	2	2
1:30-1:45						17		2
1:45-2:00	2	2			4	12		1
HOURLY TOTAL					18	HOURLY TOTAL		80

↑
NORTH

APP. #1= EB CSAH 1

APP. #2 = SB Avocet St.

APP. #3= WB CSAH 1

APP. #4= NB Avocet St.

COUNT LOCATION: CSAH 1 (Coon Rapids Blvd) @
Avocet St.

DATE: 8/22/96

APP. #2 30 MPH	
APP. #1 45 MPH	APP. #3 45 MPH
APP. #4	APP. #4

- HEAVY VEHICLE- ANY VEHICLE HAVING MORE THAN FOUR TIRES TOUCHING THE PAVEMENT
- A. TRUCKS- A HEAVY VEHICLE INVOLVED PRIMARILY IN THE TRANSPORT OF GOODS OR IN THE DELIVERY OF A SERVICE.
 - B. RV- A HEAVY VEHICLE OPERATED BY A PRIVATE MOTORIST AND INVOLVED IN THE TRANSPORT OF RECREATIONAL EQUIPMENT OR FACILITIES.
 - C. BUSES- A HEAVY VEHICLE INVOLVED IN THE TRANSPORTATION OF GROUPS OF PEOPLE.

TIME	PEDESTRIANS					HEAVY VEHICLES		
	APP. #1	APP. #2	APP. #3	APP. #4	15 MIN TOT	TRUCKS	RV	BUS
2:00-2:15PM	4		4		8	17		1
2:15-2:30						13		1
2:30-2:45						15		2
2:45-3:00	2				2	26		1
HOURLY TOTAL					10	HOURLY TOTAL		76
3:00-3:15	3	1			4	21		4
3:15-3:30			2		2	17		4
3:30-3:45						11		5
3:45-4:00		1			1	15	1	2
HOURLY TOTAL					7	HOURLY TOTAL		80
4:00-4:15			2		2	16		2
4:15-4:30						16		2
4:30-4:45	2	7	1		10	6		5
4:45-5:00	1	1			2	6		4
HOURLY TOTAL					14	HOURLY TOTAL		57
5:00-5:15	1	1			2	11		4
5:15-5:30						5		4
5:30-5:45						7		4
5:45-6:00	1	3			4	11		7
HOURLY TOTAL					6	HOURLY TOTAL		53
6:00-6:15						9		
6:15-6:30	3	4			7	5		2
6:30-6:45	2	2	1	1	6	3		1
6:45-7:00	1	1	1		3	5	1	2
HOURLY TOTAL					16	HOURLY TOTAL		28
7:00-7:15	1				1	7		
7:15-7:30	1		2		3	3		
7:30-7:45	1	1			2	4		2
7:45-8:00		1	1		2	3		
HOURLY TOTAL					8	HOURLY TOTAL		19
8:00-8:15						1		
8:15-8:30						1		1
8:30-8:45						2		3
8:45-9:00						3		
HOURLY TOTAL						HOURLY TOTAL		11
9:00-9:15						1		
9:15-9:30	1	1			2			
9:30-9:45						3		1
9:45-10:00						3		
HOURLY TOTAL					2	HOURLY TOTAL		8