

Date: 7/25/96AM 7/23/96PM

Count Number: TMC 9626

Location: CSAH 1 (COON RAPIDS BLVD)

@ EGRET BLVD.

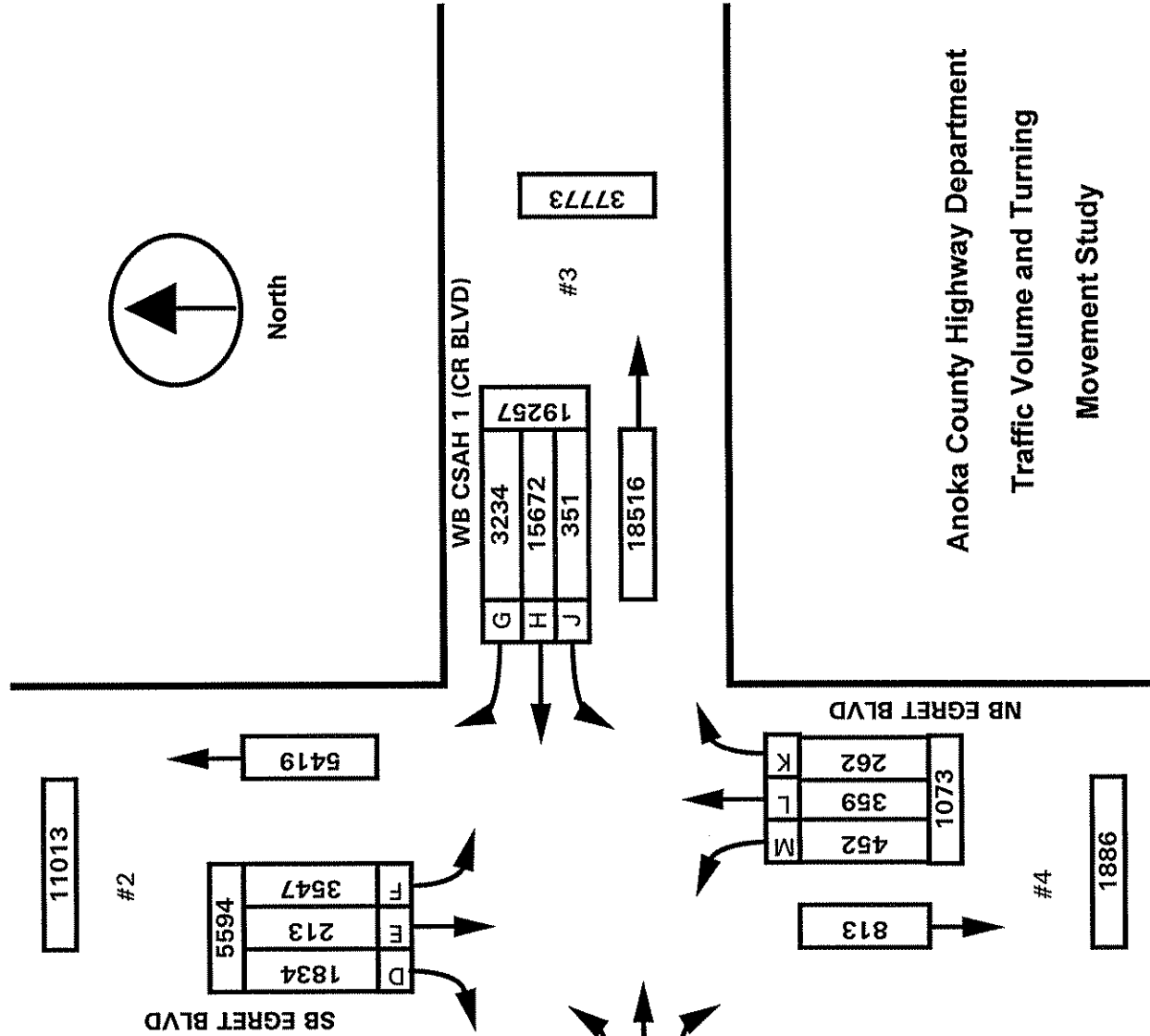

Anoka County Highway Department
Traffic Volume and Turning
Movement Study

	LANES OF APPROACH			TOTAL
	RIGHT TURN LANE	LEFT TURN LANE	THRU LANES	
#1	1	1	2	4
#2	0	1	1	2
#3	0	1	3	4
#4	0	1	1	2

ANOKA COUNTY HIGHWAY DEPARTMENT

Weather : CLEAR/RAIN IN PM

TRAFFIC ENGINEERING SECTION

Study Name: TMC9626

Counted by: Ann and Gabe

TRAFFIC STUDY

Site Code : 96260101

Card # :

Start Date: 07/23/96

Other :

Page : 1

Vehicle group 1

Start Time	EGRET BLVD From North				CSAH 1 (COON RAPIDS BL) From East				EGRET BLVD From South				CSAH 1 (COON RAPIDS BL) From West				Intvl	Exclu	Inclu
	Right	Thru	Left	HEAVY	Right	Thru	Left	HEAVY	Right	Thru	Left	HEAVY	Right	Thru	Left	HEAVY			
07/23/96																			
06:00	7	2	118	4	9	35	1	3	1	2	0	0	2	312	3	8	507	15	492
06:15	6	2	127	0	14	75	4	5	1	2	0	0	0	471	10	6	723	11	712
06:30	25	5	157	4	11	90	1	3	7	4	5	0	1	531	6	11	861	18	843
06:45	23	4	111	0	14	112	6	4	3	2	4	0	5	571	16	7	882	11	871
Hour	61	13	513	8	48	312	12	15	12	10	9	0	8	1885	35	32	2973	55	2918
07:00	14	3	153	0	11	80	3	6	3	2	4	0	1	498	15	9	802	15	787
07:15	25	12	127	1	20	136	2	4	10	7	3	0	2	526	13	9	897	14	883
07:30	30	5	140	3	19	127	1	3	3	5	5	3	1	379	18	7	749	16	733
07:45	24	4	104	0	27	136	4	9	5	4	3	0	2	440	28	9	799	18	781
Hour	93	24	524	4	77	479	10	22	21	18	15	3	6	1843	74	34	3247	63	3184
08:00	21	0	94	3	18	120	1	9	4	6	5	1	1	306	17	4	610	17	593
08:15	18	1	67	0	25	145	7	14	4	0	1	0	0	286	17	5	590	19	571
08:30	18	2	68	0	29	114	7	9	8	3	7	1	2	245	24	3	540	13	527
08:45	26	4	46	2	18	146	4	6	2	2	5	0	3	194	26	7	491	15	476
Hour	83	7	275	5	90	525	19	38	18	11	18	2	6	1031	84	19	2231	64	2167
09:00	23	2	41	3	16	108	3	9	3	3	12	1	2	161	28	7	422	20	402
09:15	25	1	43	1	20	152	7	11	2	2	8	0	1	170	29	3	475	15	460
09:30	15	2	53	2	15	132	2	8	3	7	6	1	1	191	19	8	465	19	446
09:45	29	1	41	0	21	148	4	15	3	4	6	1	4	186	27	6	496	22	474
Hour	92	6	178	6	72	540	16	43	11	16	32	3	8	708	103	24	1858	76	1782
10:00	24	0	47	0	19	137	8	11	3	5	4	0	6	208	20	6	498	17	481
10:15	20	3	41	3	36	160	3	12	1	5	11	0	6	194	31	7	533	22	511
10:30	32	2	43	1	28	168	10	8	3	0	4	1	7	195	20	2	524	12	512
10:45	37	0	37	4	24	171	3	5	4	8	3	1	4	183	26	7	517	17	500
Hour	113	5	168	8	107	636	24	36	11	18	22	2	23	780	97	22	2072	68	2004
11:00	22	2	42	0	19	188	9	9	4	3	4	0	1	185	24	10	522	19	503
11:15	26	7	34	0	30	185	7	4	7	5	6	2	2	210	21	10	556	16	540
11:30	28	5	36	4	35	210	15	12	1	5	11	0	3	197	32	8	602	24	578
11:45	35	3	52	0	28	218	9	16	7	4	5	1	3	189	29	10	609	27	582
Hour	111	17	164	4	112	801	40	41	19	17	26	3	9	781	106	38	2289	86	2203
12:00	24	4	44	3	33	182	7	10	7	5	10	2	3	208	28	11	581	26	555
12:15	19	1	49	1	38	216	4	9	10	9	5	0	4	209	22	9	605	19	586
12:30	32	5	60	2	42	217	3	8	3	8	5	1	3	245	24	10	668	21	647
12:45	25	0	40	1	33	221	5	9	4	7	8	3	8	199	25	6	594	19	575
Hour	100	10	193	7	146	836	19	36	24	29	28	6	18	861	99	36	2448	85	2363

ANOKA COUNTY HIGHWAY DEPARTMENT

Weather : CLEAR/RAIN IN PM
 Counted by: Ann and Gabe
 Ward # :
 Other :

TRAFFIC ENGINEERING SECTION
 TRAFFIC STUDY

Study Name: TMC9626
 Site Code : 96260101
 Start Date: 07/23/96
 Page : 2

Start Time	Vehicle group 1																Intvl	Exclu	Inclu
	EGRET BLVD				CSAH 1 (COON RAPIDS BL				EGRET BLVD				CSAH 1 (COON RAPIDS BL						
	From North				From East				From South				From West						
Right	Thru	Left	HEAVY	Right	Thru	Left	HEAVY	Right	Thru	Left	HEAVY	Right	Thru	Left	HEAVY	Total	Total	Total	
13:00	32	4	49	2	33	176	2	6	1	9	9	0	4	238	30	10	605	18	587
13:15	26	4	55	2	33	190	8	14	7	3	8	1	4	227	30	13	625	30	595
13:30	31	5	47	1	39	215	4	5	6	5	8	0	2	210	29	6	613	12	601
13:45	32	4	41	2	41	253	6	10	3	5	13	1	3	217	32	7	670	20	650
Hour	121	17	192	7	146	834	20	35	17	22	38	2	13	892	121	36	2513	80	2433
14:00	28	2	38	1	45	247	3	9	0	4	3	0	4	254	28	7	673	17	656
14:15	31	4	43	1	46	270	7	7	8	8	5	0	4	259	21	7	721	15	706
14:30	25	3	58	1	38	276	8	10	5	3	11	0	3	230	30	6	707	17	690
14:45	17	4	41	2	41	336	8	8	5	4	6	0	4	191	28	5	700	15	685
Hour	101	13	180	5	170	1129	26	34	18	19	25	0	15	934	107	25	2801	64	2737
15:00	35	1	40	3	75	340	4	7	7	2	10	2	5	211	34	7	783	19	764
15:15	37	2	33	0	76	368	6	7	7	9	6	0	7	214	27	4	803	11	792
15:30	28	1	46	1	80	347	2	2	6	7	10	0	6	218	36	9	799	12	787
15:45	37	8	49	1	96	463	6	12	4	12	9	1	7	219	45	8	977	22	955
Hour	137	12	168	5	327	1518	18	28	24	30	35	3	25	862	142	28	3362	64	3298
16:00	33	5	36	2	106	499	5	9	1	8	11	0	7	208	37	2	969	13	956
16:15	51	6	39	5	116	504	5	6	9	11	12	1	2	207	43	7	1024	19	1005
16:30	38	3	44	1	132	534	12	5	7	11	8	0	11	221	39	4	1070	10	1060
16:45	54	9	46	3	129	508	4	4	5	16	17	0	3	203	56	4	1061	11	1050
Hour	176	23	165	11	483	2045	26	24	22	46	48	1	23	839	175	17	4124	53	4071
17:00	48	3	55	0	166	578	7	5	3	4	11	0	5	219	36	3	1143	8	1135
17:15	41	3	53	0	156	593	15	2	3	11	8	1	5	197	37	5	1130	8	1122
17:30	41	1	59	0	166	601	9	9	5	10	11	1	1	174	41	5	1134	15	1119
17:45	53	4	53	0	112	556	8	9	1	11	12	0	3	178	44	4	1048	13	1035
Hour	183	11	220	0	600	2328	39	25	12	36	42	2	14	768	158	17	4455	44	4411
18:00	31	5	61	1	87	432	8	9	2	11	7	0	5	203	55	2	919	12	907
18:15	37	5	59	0	77	359	9	2	4	7	6	0	5	206	32	3	811	5	806
18:30	38	4	56	1	73	265	8	4	4	5	6	0	5	207	28	1	705	6	699
18:45	51	2	56	0	57	257	7	2	5	7	13	0	10	171	34	3	675	5	670
Hour	157	16	232	2	294	1313	32	17	15	30	32	0	25	787	149	9	3110	28	3082
19:00	41	5	39	0	56	271	6	4	1	4	8	0	6	194	38	2	675	6	669
19:15	34	1	40	0	43	214	10	3	2	10	8	0	8	175	36	2	586	5	581
19:30	25	5	34	1	53	238	4	4	2	6	8	0	7	188	45	1	621	6	615
19:45	27	7	49	1	49	166	7	0	4	1	7	0	4	163	35	0	520	1	519
Hour	127	18	162	2	201	889	27	11	9	21	31	0	25	720	154	5	2402	18	2384

ANOKA COUNTY HIGHWAY DEPARTMENT

TRAFFIC ENGINEERING SECTION

TRAFFIC STUDY

Weather : CLEAR/RAIN IN PM

Counted by: Ann and Gabe

Card # :

Other :

Study Name: TMC9626

Site Code : 96260101

Start Date: 07/23/96

Page : 3

Vehicle group 1

Start Time	EGRET BLVD From North				CSAH 1 (COON RAPIDS BL From East				EGRET BLVD From South				CSAH 1 (COON RAPIDS BL From West				Intvl	Exclu	Inclu
	Right	Thru	Left	HEAVY	Right	Thru	Left	HEAVY	Right	Thru	Left	HEAVY	Right	Thru	Left	HEAVY			
20:00	17	2	25	0	48	209	2	1	4	8	8	0	3	167	24	1	519	2	517
20:15	36	6	35	0	38	200	5	1	4	5	11	0	8	142	25	3	519	4	515
20:30	20	3	25	0	55	192	0	0	1	6	9	0	3	124	40	4	482	4	478
20:45	30	2	26	1	48	175	5	3	13	4	4	0	4	151	41	1	508	5	503
Hour	103	13	111	1	189	776	12	5	22	23	32	0	18	584	130	9	2028	15	2013
21:00	29	4	31	0	51	215	2	1	0	5	8	0	4	131	22	1	504	2	502
21:15	18	2	26	0	50	178	6	1	2	2	2	0	3	102	33	0	425	1	424
21:30	15	1	23	0	37	181	2	2	2	3	4	0	4	104	17	2	397	4	393
21:45	14	1	22	0	34	137	1	0	3	3	5	0	2	95	20	1	338	1	337
Hour	76	8	102	0	172	711	11	4	7	13	19	0	13	432	92	4	1664	8	1656
Total	1834	213	3547	75	3234	15672	351	414	262	359	452	27	249	14707	1826	355	43577	871	42706
% Apr.	32.3	3.7	62.5	1.3	16.4	79.6	1.7	2.1	23.8	32.6	41.0	2.4	1.4	85.8	10.6	2.0	-	-	-
% Int.	4.2	0.4	8.1	0.1	7.4	35.9	0.8	0.9	0.6	0.8	1.0	-	0.5	33.7	4.1	0.8	-	-	-

or Street Approaches:

Eastbound:

CSAH 1 (COON RAPIDS BLVD)

Data File: C:\PETRA2\DATAFILE\TMC9626.PDF
 Count Type: IMC. Channel: 0. Count Date: 7/23/96
 Number of Lanes: 2
 Approach Speed: 45
 Total Approach Traffic: 16782

Westbound:

CSAH 1 (COON RAPIDS BLVD)

Data File: C:\PETRA2\DATAFILE\TMC9626.PDF
 Count Type: IMC. Channel: 0. Count Date: 7/23/96
 Number of Lanes: 2
 Approach Speed: 45
 Total Approach Traffic: 19257

Minor Street Approaches:

Northbound:

EGRET BLVD

Data File: C:\PETRA2\DATAFILE\TMC9626.PDF
 Count Type: IMC. Channel: 0. Count Date: 7/23/96
 Number of Lanes: 2
 Approach Speed: 0
 Total Approach Traffic: 1073

Southbound:

EGRET BLVD

Data File: C:\PETRA2\DATAFILE\TMC9626.PDF
 Count Type: IMC. Channel: 0. Count Date: 7/23/96
 Number of Lanes: 2
 Approach Speed: 40
 Total Approach Traffic: 5594

Analysis of 8-Hour Volume Warrants (Criteria refers to high volume side street for that hour):

Hour	Main	Side	Warrant 1	Warrant 2	Warrant 8
Begin	(Total)	Vol. Dir. Rank	Meets? Criteria	Meets? Criteria	Meets? Criteria
0	0	0 S 17	140	70	112
1	0	0 S 18	140	70	112
2	0	0 S 19	140	70	112
3	0	0 S 20	140	70	112
4	0	0 S 21	140	70	112
5	0	0 S 22	140	70	112
6	2300	587 S 2	--BOTH-- 140	--BOTH-- 70	--BOTH-- 112
7	2489	641 S 1	--BOTH-- 140	--BOTH-- 70	--BOTH-- 112
8	1755	365 S 5	--BOTH-- 140	--BOTH-- 70	--BOTH-- 112
9	1447	276 S 14	--BOTH-- 140	--BOTH-- 70	--BOTH-- 112
10	1667	286 S 13	--BOTH-- 140	--BOTH-- 70	--BOTH-- 112
11	1849	292 S 12	--BOTH-- 140	--BOTH-- 70	--BOTH-- 112
12	1979	303 S 10	--BOTH-- 140	--BOTH-- 70	--BOTH-- 112
13	2026	330 S 7	--BOTH-- 140	--BOTH-- 70	--BOTH-- 112
14	2381	294 S 11	--BOTH-- 140	--BOTH-- 70	--BOTH-- 112
15	2892	317 S 8	--BOTH-- 140	--BOTH-- 70	--BOTH-- 112
16	3591	364 S 6	--BOTH-- 140	--BOTH-- 70	--BOTH-- 112
17	3907	414 S 3	--BOTH-- 140	--BOTH-- 70	--BOTH-- 112
18	2600	405 S 4	--BOTH-- 140	--BOTH-- 70	--BOTH-- 112
19	2016	307 S 9	--BOTH-- 140	--BOTH-- 70	--BOTH-- 112
20	1709	227 S 15	--BOTH-- 140	--BOTH-- 70	--BOTH-- 112
21	1431	186 S 16	--BOTH-- 140	--BOTH-- 70	--BOTH-- 112
22	0	0 S 23	140	70	112
23	0	0 S 24	140	70	112

Warrant Summary:

Rural values apply.

Warrant 1 - Minimum Vehicular Volumes

SATISFIED for 16 hours. Criteria--Main St.: 420; Side St.: See Volume Summary.

Warrant 2 - Interruption of Continuous Traffic

SATISFIED for 16 hours. Criteria--Main St.: 630; Side St.: See Volume Summary.

Warrant 3 - Minimum Pedestrian Volumes

NOT SATISFIED. Ped volumes too low. Criteria--190 Peds in peak hour, 100 peds in 4th high hour.

Warrant 4 - School Crossing

NOT APPLICABLE. Gap data has not been defined.

Warrant 5 - Progressive Movement

NOT SATISFIED. Adjacent signals closer than 1000 feet and/or not part of coordinated system.

Warrant 6 - Accident Experience

NOT SATISFIED. 0 correctable accidents is fewer than required 5.

Correctable Accidents: 0; Right Angle Accidents: 0; Left Turn Accidents: 0; Other Accidents: 0.

Warrant 7 - Systems Warrant

NOT SATISFIED. At least one street has no major approaches. Peak hour total entering volume: 4411.

- Approaches which are part of the principal through traffic roadway network.
- Approaches which include rural or suburban highways outside, entering or traversing a city.
- Approaches which appear as a major route in an official transportation plan.

Warrant 8 - Combination of Warrants

SATISFIED for 16 hours. Criteria--Main: 504; Side: See Volume Summary.

Warrant 9 - Four Hour Volumes

SATISFIED for 16 hours.

Warrant 10 - Peak Hour Delay

NOT APPLICABLE. Volume requirements satisfied, but side street peak hour delay not defined.

Criteria--Main St.: 800 (4 approaches), 650 (3 approaches); Side St.: 150.

Warrant 11 - Peak Hour Volume

SATISFIED for 16 hours.

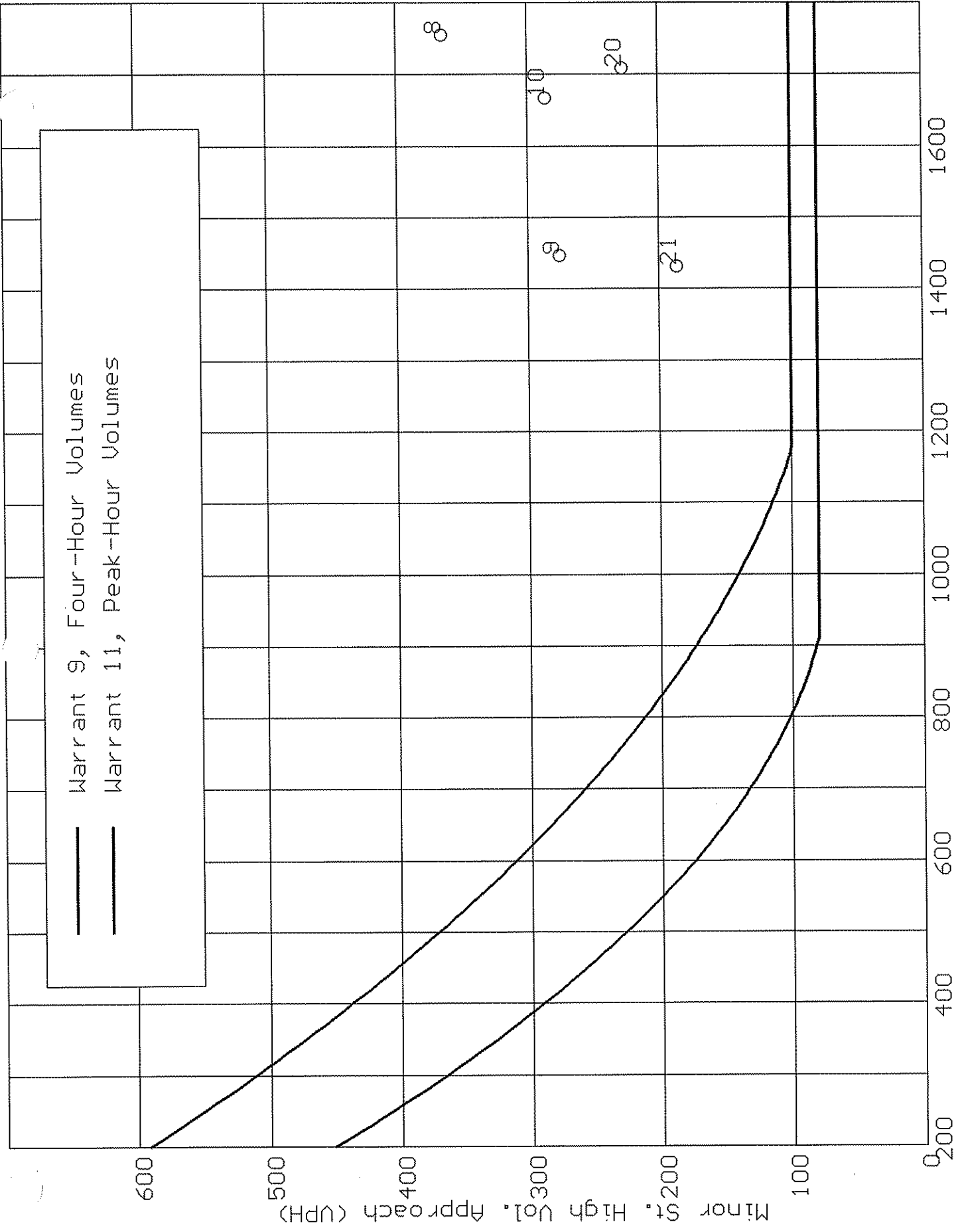

Major St. Total of Both Approaches (UPH)



NORTH

COUNT LOCATION: CSAH 1 (Coon Rapids Blvd.) @
Egret Blvd.

DATE: 7/25/96

APP. #1=
EB CSAH 1 (C.R. Blvd.)

APP. #2 =
SB Egret Blvd.

APP. #3=
WB CSAH 1 (C.R. Blvd.)

APP. #4=
NB Egret Blvd.

APP. #2
40mph

APP. #1
45mph

APP. #3
45mph

APP. #4

HEAVY VEHICLE- ANY VEHICLE HAVING MORE THAN FOUR TIRES TOUCHING THE PAVEMENT

A. TRUCKS- A HEAVY VEHICLE INVOLVED PRIMARILY IN THE TRANSPORT OF GOODS OR IN THE DELIVERY OF A SERVICE.

B. RV- A HEAVY VEHICLE OPERATED BY A PRIVATE MOTORIST AND INVOLVED IN THE TRANSPORT OF RECREATIONAL EQUIPMENT OR FACILITIES.

C. BUSES- A HEAVY VEHICLE INVOLVED IN THE TRANSPORTATION OF GROUPS OF PEOPLE.

TIME	PEDESTRIANS					HEAVY VEHICLES		
	APP. #1	APP. #2	APP. #3	APP. #4	15 MIN TOT	TRUCKS	RV	BUS
6:00-6:15AM						10		5
6:15-6:30			1		1	6		5
6:30-6:45			2		2	12		6
6:45-7:00			1		1	5		5
HOURLY TOTAL					4	HOURLY TOTAL		54
7:00-7:15						7	1	7
7:15-7:30	1			1	2	9		5
7:30-7:45		1			1	9		7
7:45-8:00						13		5
HOURLY TOTAL					3	HOURLY TOTAL		63
8:00-8:15						11		7
8:15-8:30						14		5
8:30-8:45						11		2
8:45-9:00				1	1	11		4
HOURLY TOTAL					1	HOURLY TOTAL		65
9:00-9:15	1			2	3	17		3
9:15-9:30	4				4	13		2
9:30-9:45	2			1	3	14		5
9:45-10:00						17		5
HOURLY TOTAL					10	HOURLY TOTAL		76
10:00-10:15						16		1
10:15-10:30						17	2	3
10:30-10:45						12		
10:45-11:00						13	1	3
HOURLY TOTAL						HOURLY TOTAL		68
11:00-11:15						13		6
11:15-11:30						13	1	2
11:30-11:45	5					22		2
11:45-12:00		2			2	22	1	4
HOURLY TOTAL					2	HOURLY TOTAL		86
12:00-12:15						20	1	4
12:15-12:30	1		2	2	5	15		4
12:30-12:45						16		5
12:45-1:00						18		1
HOURLY TOTAL					5	HOURLY TOTAL		84
1:00-1:15						15		3
1:15-1:30	3				3	27		3
1:30-1:45				1	1	11		2
1:45-2:00				3	3	19		
HOURLY TOTAL					7	HOURLY TOTAL		80



NORTH

COUNT LOCATION: CSAH 1 (Coon Rapids Blvd.) @
Egret Blvd.

DATE: 7/23/96

APP. #1=
EB CSAH 1 (C.R. Blvd.)

APP. #2 =
SB Egret Blvd.

APP. #3=
WB CSAH 1 (C.R. Blvd.)

APP. #4=
NB Egret Blvd.

APP. #2
40mph

APP. #1
45mph

APP. #3
45mph

APP. #4

- HEAVY VEHICLE- ANY VEHICLE HAVING MORE THAN FOUR TIRES TOUCHING THE PAVEMENT
- A. TRUCKS- A HEAVY VEHICLE INVOLVED PRIMARILY IN THE TRANSPORT OF GOODS OR IN THE DELIVERY OF A SERVICE.
 - B. RV- A HEAVY VEHICLE OPERATED BY A PRIVATE MOTORIST AND INVOLVED IN THE TRANSPORT OF RECREATIONAL EQUIPMENT OR FACILITIES.
 - C. BUSES- A HEAVY VEHICLE INVOLVED IN THE TRANSPORTATION OF GROUPS OF PEOPLE.

TIME	PEDESTRIANS					HEAVY VEHICLES		
	APP. #1	APP. #2	APP. #3	APP. #4	15 MIN TOT	TRUCKS	RV	BUS
2:00-2:15PM				1	1	14		3
2:15-2:30						15		
2:30-2:45						13		4
2:45-3:00						14	1	
HOURLY TOTAL					1	HOURLY TOTAL		64
3:00-3:15	3				3	12	1	5
3:15-3:30	7			1	8	9		1
3:30-3:45						8		4
3:45-4:00						19		3
HOURLY TOTAL					11	HOURLY TOTAL		62
4:00-4:15	1	1			2	16		3
4:15-4:30		3			3	12		3
4:30-4:45	1			1	2	5		5
4:45-5:00	1	1	1		3	5		5
HOURLY TOTAL					10	HOURLY TOTAL		54
5:00-5:15						7		4
5:15-5:30						6		1
5:30-5:45	3	2			5	9	1	2
5:45-6:00	1				1	8		7
HOURLY TOTAL					6	HOURLY TOTAL		45
6:00-6:15				5	5	6	1	3
6:15-6:30						4		1
6:30-6:45						4		2
6:45-7:00				1	1	4		
HOURLY TOTAL					6	HOURLY TOTAL		25
7:00-7:15	2				2	4		2
7:15-7:30						1		2
7:30-7:45						5		1
7:45-8:00						1		
HOURLY TOTAL					2	HOURLY TOTAL		16
8:00-8:15	1				1	2		
8:15-8:30	1		1		2	2	1	1
8:30-8:45						2		2
8:45-9:00	4				4	4		1
HOURLY TOTAL					7	HOURLY TOTAL		15
9:00-9:15						2		
9:15-9:30				1	1	1		
9:30-9:45						1		2
9:45-10:00						1		
HOURLY TOTAL					1	HOURLY TOTAL		7