

Date : 6/04/99AM 6/14/99PM

Count Number : TMC9906

Location : CSAH 11 (FOLEY BLVD.) @

EGRET BLVD.

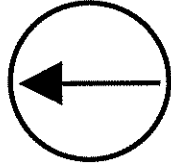

North

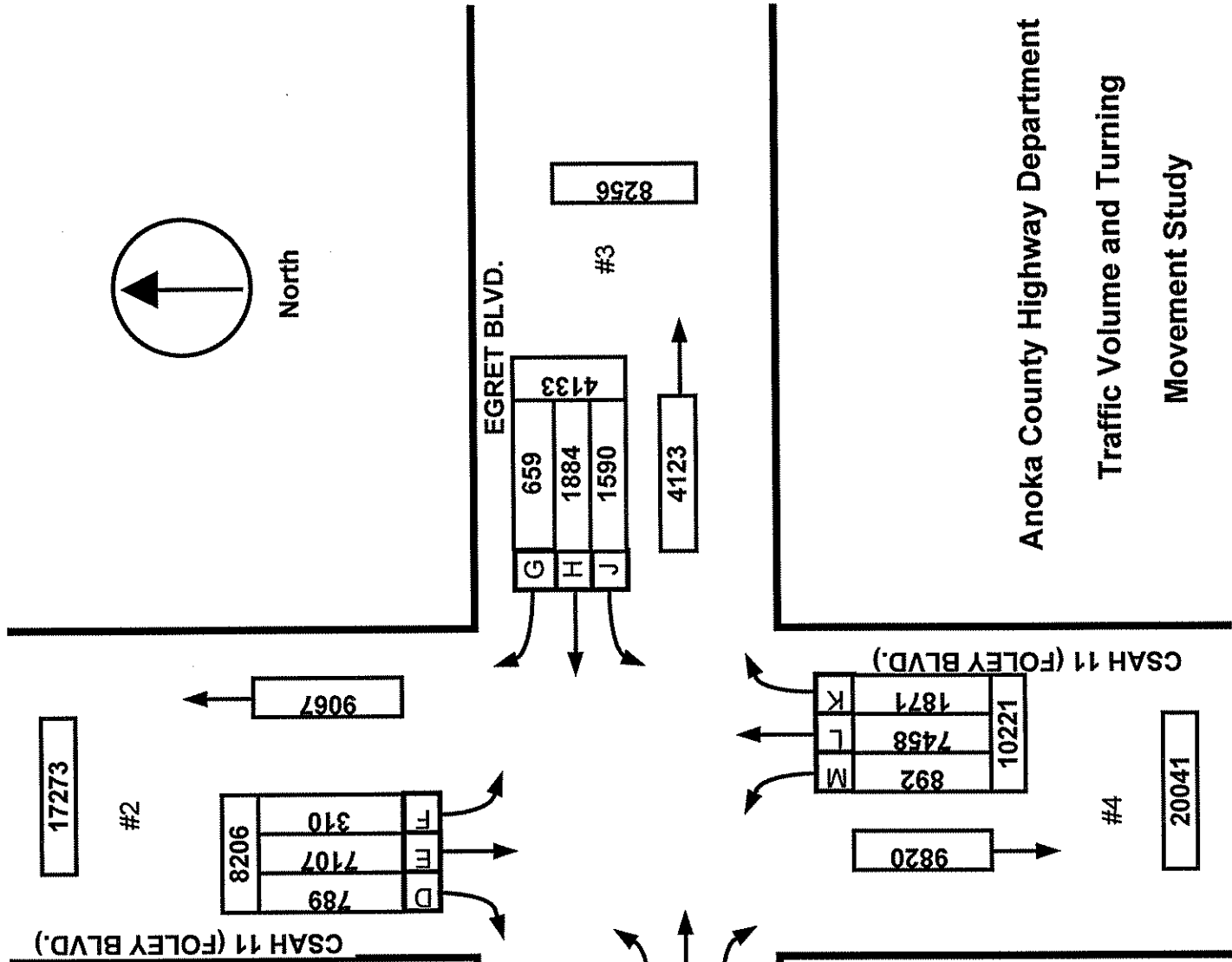

	LANES OF APPROACH			TOTAL
	RIGHT TURN LANE	LEFT TURN LANE	THRU LANES	
#1	0	1	1	2
#2	1	0	1	2
#3	0	1	1	2
#4	1	0	1	2

Anoka County Highway Department
 Traffic Volume and Turning
 Movement Study

Anoka County Highway Department Traffic Volume & Turning Movement Study

File Name : TMC9906
Site Code : 99060101
Start Date : 06/04/1999
Page : 1

Groups Printed: 1 - 1 - Unshifted

Start Time	CSAH 11 (Foley Blvd) Southbound				Egret Blvd. Westbound				CSAH 11 (Foley Blvd) Northbound				Egret Blvd. Eastbound				Exclu. Total	Inclu. Total	Int. Total
	Left	Thru	Right	Peds	Left	Thru	Right	Peds	Left	Thru	Right	Peds	Left	Thru	Right	Peds			
Factor	1.0	1.0	1.0	1.0	1.0	1.0	1.0	1.0	1.0	1.0	1.0	1.0	1.0	1.0	1.0	1.0			
06:00 AM	0	188	7	0	31	5	0	0	3	18	5	0	5	17	27	0	0	306	306
06:15 AM	3	233	10	0	56	10	1	1	3	33	8	3	8	28	16	0	4	409	413
06:30 AM	3	236	4	2	54	14	2	0	2	29	5	1	4	25	28	0	3	406	409
06:45 AM	5	272	4	5	65	25	3	0	5	41	10	3	4	35	31	2	10	500	510
Total	11	929	25	7	206	54	6	1	13	121	28	7	21	105	102	2	17	1621	1638
07:00 AM	3	290	6	2	44	15	2	0	5	42	8	2	9	33	37	1	5	494	499
07:15 AM	0	277	4	1	52	26	6	2	6	46	7	3	9	45	19	3	9	497	506
07:30 AM	6	312	17	6	51	19	3	2	2	60	11	1	8	20	25	1	10	534	544
07:45 AM	3	261	13	8	36	30	2	4	4	70	14	3	15	42	22	2	17	512	529
Total	12	1140	40	17	183	90	13	8	17	218	40	9	41	140	103	7	41	2037	2078
08:00 AM	4	209	17	2	39	24	0	2	7	47	10	5	12	22	19	6	15	410	425
08:15 AM	5	189	15	2	43	17	3	3	10	81	13	5	8	18	20	1	11	422	433
08:30 AM	5	167	11	7	22	19	7	1	8	46	16	2	7	29	18	5	15	355	370
08:45 AM	3	149	8	3	34	20	1	2	13	40	12	4	8	27	8	1	10	323	333
Total	17	714	51	14	138	80	11	8	38	214	51	16	35	96	65	13	51	1510	1561
09:00 AM	9	127	9	2	25	24	3	0	9	55	15	3	9	25	17	3	8	327	335
09:15 AM	3	103	16	3	28	14	7	1	8	50	12	2	9	21	20	1	7	291	298
09:30 AM	6	86	17	2	16	25	4	2	8	60	13	4	13	23	14	2	10	285	295
09:45 AM	2	87	13	1	9	19	9	0	9	54	16	0	11	17	15	2	3	261	264
Total	20	403	55	8	78	82	23	3	34	219	56	9	42	86	66	8	28	1164	1192
10:00 AM	6	76	4	0	18	21	9	0	12	65	10	3	2	9	23	2	5	255	260
10:15 AM	3	79	8	1	24	12	9	1	7	78	16	3	9	23	12	1	6	280	286
10:30 AM	8	75	10	1	18	17	7	1	13	69	18	4	9	18	19	3	9	281	290
10:45 AM	8	85	12	0	22	17	7	0	8	60	23	5	13	16	19	1	6	290	296
Total	25	315	34	2	82	67	32	2	40	272	67	15	33	66	73	7	26	1106	1132
11:00 AM	7	69	12	4	19	13	7	1	9	90	17	4	19	23	18	2	11	303	314
11:15 AM	3	98	14	2	24	28	9	5	15	93	11	4	13	28	17	1	12	353	365
11:30 AM	7	83	9	1	11	22	14	2	13	89	21	2	11	30	16	1	6	326	332
11:45 AM	3	99	14	4	17	16	12	2	11	96	23	2	20	34	20	1	9	365	374
Total	20	349	49	11	71	79	42	10	48	368	72	12	63	115	71	5	38	1347	1385
12:00 PM	4	80	16	3	24	21	16	0	13	109	26	4	11	29	13	2	9	362	371
12:15 PM	11	80	10	1	20	22	8	2	9	109	26	2	13	16	20	0	5	344	349
12:30 PM	0	3	0	0	15	28	12	1	12	101	31	3	13	16	11	1	5	242	247
12:45 PM	4	85	12	1	7	21	11	0	16	83	12	5	14	29	21	3	9	315	324
Total	19	248	38	5	66	92	47	3	50	402	95	14	51	90	65	6	28	1263	1291
01:00 PM	5	83	12	3	15	23	6	3	19	103	20	5	8	27	19	1	12	340	352
01:15 PM	7	92	9	5	22	38	10	1	22	106	25	1	14	20	18	1	8	383	391
01:30 PM	3	85	17	1	17	32	13	0	15	111	26	7	12	24	17	1	9	372	381
01:45 PM	7	80	12	1	27	17	18	4	9	103	25	3	11	38	23	1	9	370	379
Total	22	340	50	10	81	110	47	8	65	423	96	16	45	109	77	4	38	1465	1503
02:00 PM	14	180	28	2	23	25	12	4	11	97	21	0	11	29	15	1	7	466	473
02:15 PM	2	92	12	2	33	22	7	4	17	102	29	0	13	36	13	4	10	378	388
02:30 PM	8	91	13	1	20	29	7	7	16	120	35	0	17	26	19	1	9	401	410
02:45 PM	5	87	12	4	23	37	19	4	17	166	43	0	19	30	11	1	9	469	478
Total	29	450	65	9	99	113	45	19	61	485	128	0	60	121	58	7	35	1714	1749
03:00 PM	8	74	8	0	31	33	14	3	22	155	47	0	15	35	19	0	3	461	464
3:15 PM	2	83	4	1	25	35	12	3	17	171	40	0	7	25	16	1	5	437	442
03:30 PM	4	100	11	1	25	28	10	4	27	196	58	0	13	30	19	0	5	521	526
03:45 PM	4	70	8	2	16	37	14	6	20	237	62	0	26	36	11	0	8	541	549
Total	18	327	31	4	97	133	50	16	86	759	207	0	61	126	65	1	21	1960	1981

Anoka County Highway Department Traffic Volume & Turning Movement Study

File Name : TMC9906
Site Code : 99060101
Start Date : 06/04/1999
Page : 2

Groups Printed: 1 - 1 - Unshifted

Start Time	CSAH 11 (Foley Blvd) Southbound				Egret Blvd. Westbound				CSAH 11 (Foley Blvd) Northbound				Egret Blvd. Eastbound				Exclu. Total	Inclu. Total	Int. Total
	Left	Thru	Right	Peds	Left	Thru	Right	Peds	Left	Thru	Right	Peds	Left	Thru	Right	Peds			
Factor	1.0	1.0	1.0	1.0	1.0	1.0	1.0	1.0	1.0	1.0	1.0	1.0	1.0	1.0	1.0	1.0			
04:00 PM	4	73	14	1	20	35	14	1	23	228	62	0	29	34	23	1	3	559	562
04:15 PM	5	80	13	0	25	42	18	4	19	225	52	0	13	37	16	0	4	545	549
04:30 PM	3	68	20	1	25	50	22	0	22	297	73	0	24	40	15	2	3	659	662
04:45 PM	5	105	15	2	30	62	20	2	28	268	85	0	32	62	25	0	4	737	741
Total	17	326	62	4	100	189	74	7	92	1018	272	0	98	173	79	3	14	2500	2514
05:00 PM	7	112	10	1	23	63	17	2	30	315	69	1	30	42	12	0	4	730	734
05:15 PM	3	107	19	1	27	59	14	1	20	320	73	2	28	49	21	1	5	740	745
05:30 PM	0	113	17	2	23	67	25	1	25	258	54	0	27	54	20	1	4	683	687
05:45 PM	3	64	11	1	28	56	19	4	26	223	63	0	37	53	16	0	5	599	604
Total	13	396	57	5	101	245	75	8	101	1116	259	3	122	198	69	2	18	2752	2770
06:00 PM	5	80	16	1	14	48	12	0	22	194	58	2	15	39	13	1	4	516	520
06:15 PM	4	91	18	1	29	51	17	3	15	158	38	0	24	42	26	0	4	513	517
06:30 PM	4	75	18	1	17	31	12	1	13	123	32	0	21	33	21	1	3	400	403
06:45 PM	3	70	11	0	16	35	8	0	14	141	34	0	13	38	11	0	0	394	394
Total	16	316	63	3	76	165	49	4	64	616	162	2	73	152	71	2	11	1823	1834
07:00 PM	6	71	8	0	25	35	15	1	21	114	30	0	19	46	20	0	1	410	411
07:15 PM	8	117	15	0	20	35	19	1	11	98	36	0	24	30	15	0	1	428	429
07:30 PM	9	97	13	1	19	28	12	2	14	112	29	0	15	35	17	0	3	400	403
07:45 PM	5	90	19	0	10	31	16	1	10	91	30	0	23	25	5	0	1	355	356
Total	28	375	55	1	74	129	62	5	56	415	125	0	81	136	57	0	6	1593	1599
8:00 PM	6	87	20	0	18	49	10	0	21	100	35	0	24	40	16	0	0	426	426
08:15 PM	7	62	16	0	16	30	14	0	15	87	23	0	26	26	10	2	2	332	334
08:30 PM	11	57	18	0	24	38	7	0	19	133	32	0	11	28	18	0	0	396	396
08:45 PM	6	76	14	0	24	31	13	1	19	112	24	0	17	22	17	0	1	375	376
Total	30	282	68	0	82	148	44	1	74	432	114	0	78	116	61	2	3	1529	1532
09:00 PM	3	49	12	2	16	19	11	0	25	103	36	0	21	34	15	0	2	344	346
09:15 PM	4	53	16	0	17	39	11	0	12	108	26	0	15	34	14	0	0	349	349
09:30 PM	1	47	9	1	13	27	9	0	10	101	20	0	7	25	7	0	1	276	277
09:45 PM	5	48	9	0	10	23	8	0	6	68	17	1	3	20	5	0	1	222	223
Total	13	197	46	3	56	108	39	0	53	380	99	1	46	113	41	0	4	1191	1195
Grand Total	310	7107	789	103	1590	1884	659	103	892	7458	1871	104	950	1942	1123	69	379	26575	26954
Approch %	3.8	86.6	9.6		38.5	45.6	15.9		8.7	73.0	18.3		23.7	48.4	28.0				
Total %	1.2	26.7	3.0		6.0	7.1	2.5		3.4	28.1	7.0		3.6	7.3	4.2		1.4	98.6	

or Street Approaches:

Southbound:

CSAH 11 (Foley Blvd)

Data File: C:\APPS\Data Files\TMC9906.war
 Count Type: IMC. Channel: 0. Count Date: 6/ 4/99
 Number of Lanes: 2
 Approach Speed: 40
 Total Approach Traffic: 8206

Minor Street Approaches:

Northbound:

CSAH 11 (Foley Blvd)

Data File: C:\APPS\Data Files\TMC9906.war
 Count Type: IMC. Channel: 0. Count Date: 6/ 4/99
 Number of Lanes: 2
 Approach Speed: 40
 Total Approach Traffic: 10221

Eastbound:

Egret Blvd.

Data File: C:\APPS\Data Files\TMC9906.war
 Count Type: IMC. Channel: 0. Count Date: 6/ 4/99
 Number of Lanes: 2
 Approach Speed: 0
 Total Approach Traffic: 4015

Westbound:

Egret Blvd.

Data File: C:\APPS\Data Files\TMC9906.war
 Count Type: IMC. Channel: 0. Count Date: 6/ 4/99
 Number of Lanes: 2
 Approach Speed: 0
 Total Approach Traffic: 4133

Analysis of 8-Hour Volume Warrants (Criteria refers to high volume side street for that hour):

Hour	Main Begin (Total)	Side			Warrant 1		Warrant 2		Warrant 8	
		Vol.	Dir.	Rank	Meets?	Criteria	Meets?	Criteria	Meets?	Criteria
0	0	0	W	17		200		100		160
1	0	0	W	18		200		100		160
2	0	0	W	19		200		100		160
3	0	0	W	20		200		100		160
4	0	0	W	21		200		100		160
5	0	0	W	22		200		100		160
6	965	266	W	16	--BOTH--	200	--BOTH--	100	--BOTH--	160
7	1192	286	W	15	--BOTH--	200	--BOTH--	100	--BOTH--	160
8	782	303	N	14	--BOTH--	200	SIDE	100	--BOTH--	160
9	478	309	N	13	SIDE	200	SIDE	100	SIDE	160
10	374	379	N	12	SIDE	200	SIDE	100	SIDE	160
11	418	488	N	11	SIDE	200	SIDE	100	SIDE	160
12	305	547	N	9	SIDE	200	SIDE	100	SIDE	160
13	412	584	N	8	SIDE	200	SIDE	100	SIDE	160
14	544	674	N	5	SIDE	200	SIDE	100	SIDE	160
15	376	1052	N	3	SIDE	200	SIDE	100	SIDE	160
16	405	1382	N	2	SIDE	200	SIDE	100	SIDE	160
17	466	1476	N	1	SIDE	200	SIDE	100	SIDE	160
18	395	842	N	4	SIDE	200	SIDE	100	SIDE	160
19	458	596	N	7	SIDE	200	SIDE	100	SIDE	160
20	380	620	N	6	SIDE	200	SIDE	100	SIDE	160
21	256	532	N	10	SIDE	200	SIDE	100	SIDE	160
22	0	0	W	23		200		100		160
23	0	0	W	24		200		100		160

Warrant Summary:

Urban values apply.

Warrant 1 - Minimum Vehicular Volumes

NOT SATISFIED. Required values reached for 3 hours. Criteria--Main St.: 600; Side St.: See Volume Summary.

Warrant 2 - Interruption of Continuous Traffic

NOT SATISFIED. Required values reached for 2 hours. Criteria--Main St.: 900; Side St.: See Volume Summary.

Warrant 3 - Minimum Pedestrian Volumes

NOT SATISFIED. Ped volumes too low. Criteria--190 Peds in peak hour, 100 peds in 4th high hour.

Warrant 4 - School Crossing

NOT APPLICABLE. Gap data has not been defined.

Warrant 5 - Progressive Movement

NOT SATISFIED. Adjacent signals closer than 1000 feet and/or not part of coordinated system.

Warrant 6 - Accident Experience

NOT SATISFIED. 0 correctable accidents is fewer than required 5.

Correctable Accidents: 0; Right Angle Accidents: 0; Left Turn Accidents: 0; Other Accidents: 0.

Warrant 7 - Systems Warrant

NOT SATISFIED. At least one street has no major approaches. Peak hour total entering volume: 2752.

- Approaches which are part of the principal through traffic roadway network.
- Approaches which include rural or suburban highways outside, entering or traversing a city.
- Approaches which appear as a major route in an official transportation plan.

Warrant 8 - Combination of Warrants

NOT SATISFIED. Required values reached for 3 hours. Criteria--Main: 720; Side: See Volume Summary.

Warrant 9 - Four Hour Volumes

SATISFIED for 11 hours.

Warrant 10 - Peak Hour Delay

NOT SATISFIED. Peak hour (1700 hours) volume not adequate.

Criteria--Main St.: 800 (4 approaches), 650 (3 approaches); Side St.: 150.

Warrant 11 - Peak Hour Volume

SATISFIED for 6 hours.

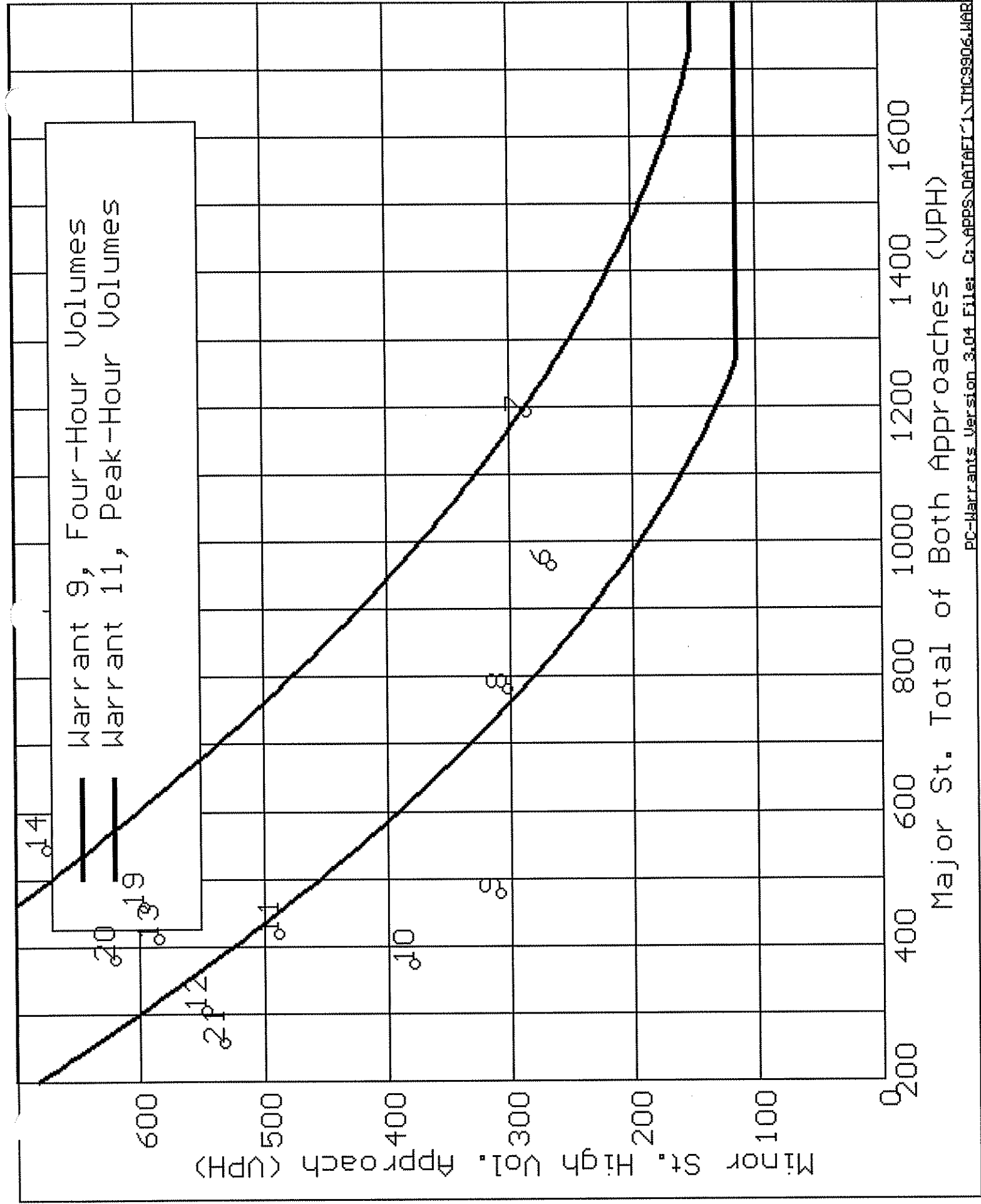

Major St. Total of Both Approaches (VPH)



COUNT LOCATION:

CSAH 11 (Foley Blvd.) @
Egret Blvd.

DATE:

6/4/99

APP. #1= EB Egret Blvd.
APP. #2 = SB CSAH 11 (Foley Blvd.)
APP. #3= WB Egret Blvd.
APP. #4= NB CSAH 11 Foley Blvd.

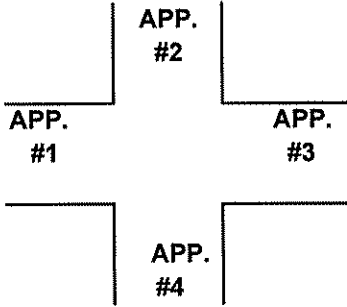

HEAVY VEHICLE- ANY VEHICLE HAVING MORE THAN FOUR TIRES TOUCHING THE PAVEMENT
A. TRUCKS- A HEAVY VEHICLE INVOLVED PRIMARILY IN THE TRANSPORT OF GOODS OR IN THE DELIVERY OF A SERVICE.
B. RV- A HEAVY VEHICLE OPERATED BY A PRIVATE MOTORIST AND INVOLVED IN THE TRANSPORT OF RECREATIONAL EQUIPMENT OR FACILITIES.
C. BUSES- A HEAVY VEHICLE INVOLVED IN THE TRANSPORTATION OF GROUPS OF PEOPLE.

TIME	PEDESTRIANS					HEAVY VEHICLES		
	APP. #1	APP. #2	APP. #3	APP. #4	15 MIN TOT	TRUCKS	RV	BUS
6:00-6:15AM								1
6:15-6:30						3		2
6:30-6:45						1		
6:45-7:00						2		8
HOURLY TOTAL						HOURLY TOTAL		17
7:00-7:15						1		4
7:15-7:30						4		4
7:30-7:45						2		5
7:45-8:00						2		11
HOURLY TOTAL						HOURLY TOTAL		33
8:00-8:15						5	2	13
8:15-8:30						4		6
8:30-8:45						7		8
8:45-9:00						6		8
HOURLY TOTAL						HOURLY TOTAL		59
9:00-9:15						5		3
9:15-9:30						4		3
9:30-9:45						9		1
9:45-10:00						3		
HOURLY TOTAL						HOURLY TOTAL		28
10:00-10:15						6		
10:15-10:30						4		1
10:30-10:45				1	1	6	1	2
10:45-11:00						9		
HOURLY TOTAL					1	HOURLY TOTAL		29
11:00-11:15		1			1	9		
11:15-11:30						9		2
11:30-11:45				1	1	4		3
11:45-12:00						7		4
HOURLY TOTAL					2	HOURLY TOTAL		38
12:00-12:15						5		2
12:15-12:30						3	2	2
12:30-12:45	1				1	6		2
12:45-1:00						8		3
HOURLY TOTAL					1	HOURLY TOTAL		33
1:00-1:15						10		5
1:15-1:30						3		1
1:30-1:45	1			2	3	9		1
1:45-2:00	1			2	3	7		1
HOURLY TOTAL					6	HOURLY TOTAL		37



COUNT LOCATION:

CSAH 11 (Foley Blvd.) @
Egret Blvd.

DATE:

6/14/99

APP. #1= EB Egret Blvd.

APP. #2 = SB CSAH 11
Foley Blvd.

APP. #3= WB Egret Blvd.

APP. #4= NB CSAH 11
Foley Blvd.

APP.
#2

APP.
#1

APP.
#3

APP.
#4

- HEAVY VEHICLE- ANY VEHICLE HAVING MORE THAN FOUR TIRES TOUCHING THE PAVEMENT
- A. TRUCKS- A HEAVY VEHICLE INVOLVED PRIMARILY IN THE TRANSPORT OF GOODS OR IN THE DELIVERY OF A SERVICE.
 - B. RV- A HEAVY VEHICLE OPERATED BY A PRIVATE MOTORIST AND INVOLVED IN THE TRANSPORT OF RECREATIONAL EQUIPMENT OR FACILITIES.
 - C. BUSES- A HEAVY VEHICLE INVOLVED IN THE TRANSPORTATION OF GROUPS OF PEOPLE.

TIME	PEDESTRIANS					HEAVY VEHICLES		
	APP. #1	APP. #2	APP. #3	APP. #4	15 MIN TOT	TRUCKS	RV	BUS
2:00-2:15PM						6		
2:15-2:30						9		1
2:30-2:45						10		
2:45-3:00						4		3
HOURLY TOTAL						HOURLY TOTAL		33
3:00-3:15						2		1
3:15-3:30						3		1
3:30-3:45			3		3	5		
3:45-4:00						7		1
HOURLY TOTAL					3	HOURLY TOTAL		20
4:00-4:15						2		
4:15-4:30						2		1
4:30-4:45						1		
4:45-5:00		1			1	5		
HOURLY TOTAL					1	HOURLY TOTAL		11
5:00-5:15						5	1	1
5:15-5:30						1		
5:30-5:45						1		1
5:45-6:00			1		1	3	1	1
HOURLY TOTAL					1	HOURLY TOTAL		15
6:00-6:15						2		
6:15-6:30						2		2
6:30-6:45	1				1	2		1
6:45-7:00	1	8	2	1	12	1		
HOURLY TOTAL					13	HOURLY TOTAL		10
7:00-7:15						1		
7:15-7:30						1		1
7:30-7:45		1	1		2	2		1
7:45-8:00	1			1	2	1		
HOURLY TOTAL					4	HOURLY TOTAL		7
8:00-8:15								
8:15-8:30	2	1	1		4	1		1
8:30-8:45				1	1			
8:45-9:00						1		
HOURLY TOTAL					5	HOURLY TOTAL		3
9:00-9:15						1		
9:15-9:30								
9:30-9:45						1		
9:45-10:00								
HOURLY TOTAL						HOURLY TOTAL		2