

ASC/2S-2100 CONTROLLER WITH:

- CONFIGURATION EEPROM 32790C1440
- SOFTWARE: V1.72
- SPECIAL SOFTWARE: SEE BELOW FUNCTION
- OVERLAPS
 - IN EEPROM
 - KEYBOARD ENTERED
- ANALOG TELEMETRY MODULE: 32825G1
- F/O TELEMETRY MODULE: 33525G1
- TEST INPUT A =
- TEST INPUT B =

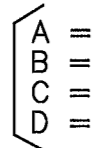

LEGEND

BIU	BUS INTERFACE UNIT
BU()	C/C, BIU ()
CB()	CIRCUIT BREAKER ()
C/C	CONNECTING CABLE
CCA	CONTROLLER CABLE "A"
CDP	C/C, DR POWER
CMA	MMU/CMU CABLE "A"
CMB	MMU/CMU CABLE "B"
CPO	C/C PRE-EMPT OUTPUTS
CPP	C/C PRE-EMPT POWER
DR	DETECTOR RACK
DS()	DOOR SWITCH ()
FL()	FLASHER ()
FR()	FLASH XFER. RELAY
LS()	LOAD SWITCH
MC	MERCURY CONTACTOR
MP	MAIN PANEL
PAP	POWER-AUX PANEL
PSP	CAB. PWR. SUPPLY
SA	SURGE ARRESTOR
TB-()	TERM. BLOCK ()

MAIN PANEL PLUG-IN REQUIREMENTS

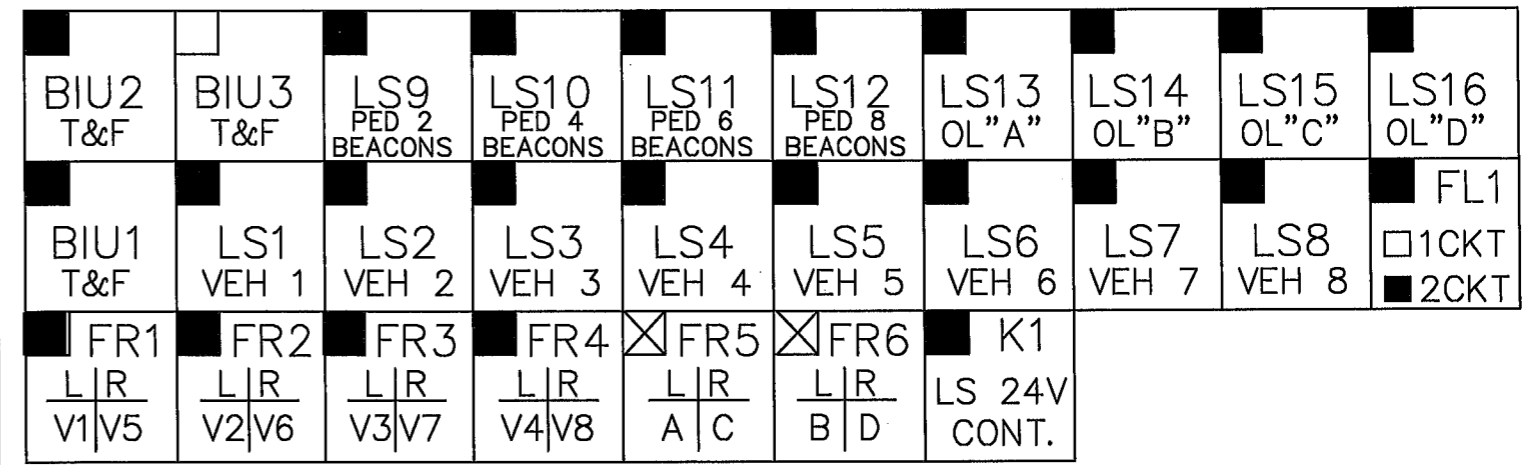

■ DENOTES TYPE OF OPERATION AND/OR WHERE PLUG-IN IS REQUIRED. L = LEFT, R = RIGHT.
 ⊗ DENOTES WHERE "UNUSED RED" JUMPER PART NUMBER 32448G1 IS REQUIRED. INSTALL BETWEEN PINS 1 & 3 FOR LOAD SWITCH OR PINS 6 & 8 AND 5 & 7 FOR FLASH TRANSFER RELAY.

FLASH:
 □ ø2&6 YELLOW, ALL OTHERS RED.
 ■ ALL RED.
 ■ RELAYS DE-ENERGIZED FOR FLASH.
 □ RELAYS ENERGIZED FOR FLASH.

FLASHER	
PIN	FUNCTION
7	CIRCUIT #1
8	CIRCUIT #2
9	CHASSIS GND
10	AC COMMON
11	115 VAC
12	-----

LOAD SWITCH	
PIN	FUNCTION
1	115 VAC
2	CHASSIS GND
3	RED/DW OUTPUT
4	-----
5	YEL OUTPUT
6	RED/DW INPUT
7	GRN/W OUTPUT
8	YEL INPUT
9	+24 VDC
10	GRN/W INPUT
11	AC COMMON
12	-----

① 2.2K 10W

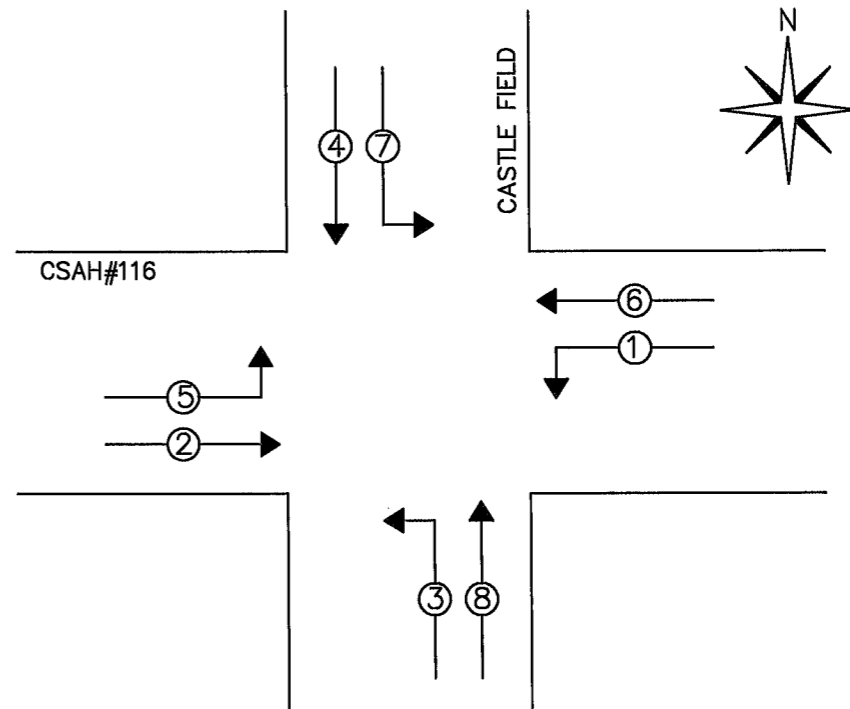

SHEET 1 OF 11

3 USE ONLY COPPER CONDUCTORS FOR FIELD AND SERVICE CONNECTIONS.
 2 CONNECT A.C. SERVICE TO TERMINAL BLOCK 501 (LINE), 502 (NEUTRAL) AND GB2 (EARTH) ON RIGHT SIDEWALL OF CABINET.
 ① INSTALL 2.2K, 10 WATT LOAD RESISTORS BETWEEN PINS 7 AND 11 ON LOAD SWITCHES 9, 10, 11 & 12.
 NOTES: UNLESS SPECIFIED OTHERWISE

DESIGNER G.V. T.C.C.	DATE 02/03/97	ECONOLITE CONTROL PRODUCTS INC.	TRAFFIC CONTROL CORPORATION 5653 MEMORIAL AVE. OAK PARK HTS, MN 55082
DRAWN MA TCC	DATE 6/9/04		
CABINET SIZE	CABINET SPECIFICATION: TS2TYPE1 2004 ANOKA COUNTY		
INSPECTED	CUSTOMER: ANOKA COUNTY HIGHWAY DEPARTMENT		
APPROVED	INTERSECTION: CSAH#116 AT CASTLE FIELD BLVD		
CUSTOMER P.O.	INSTALLED BY	SALES ORDER NO.	SIZE B
			DRAWING #TS20216PG INTERC

AUXILLARY SWITCH PANEL

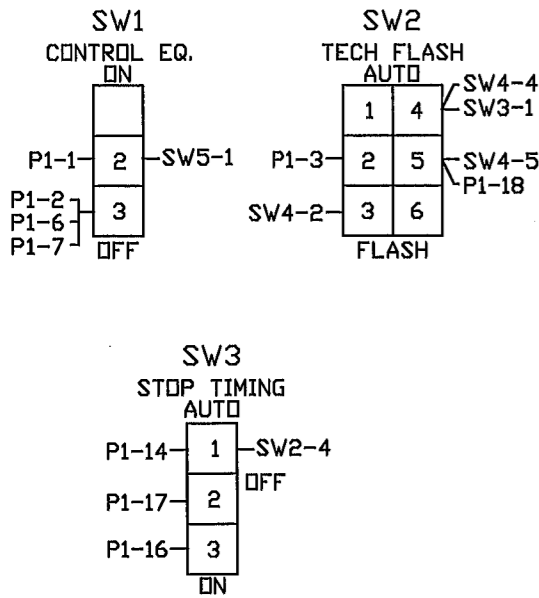

POLICE SWITCH PANEL

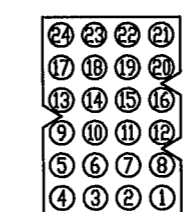
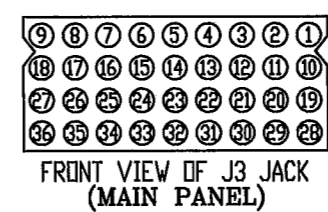
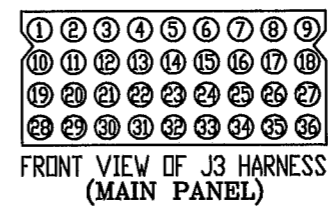
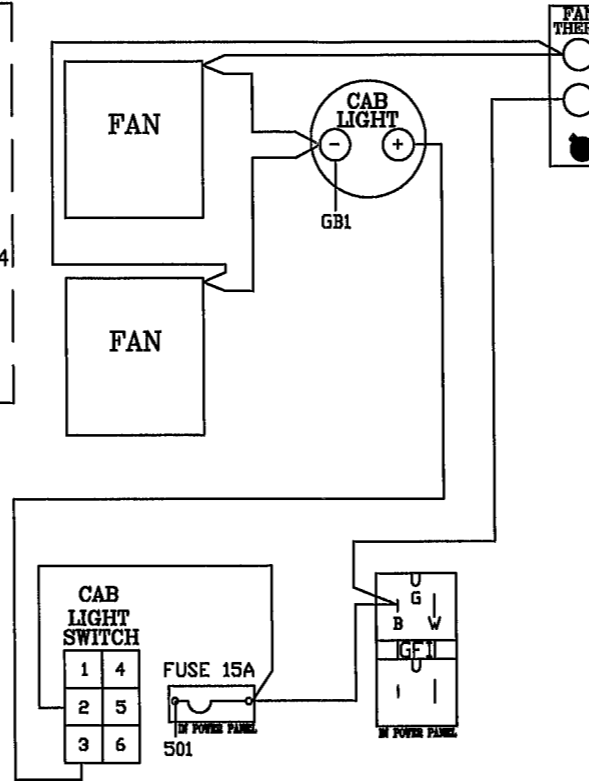
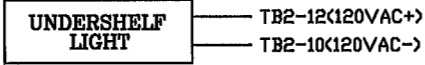
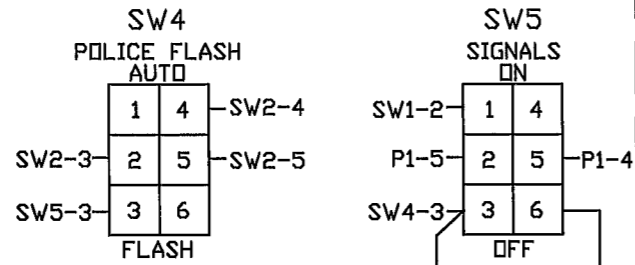

FRONT VIEW OF J1 HARNESS (SWITCH PANEL)

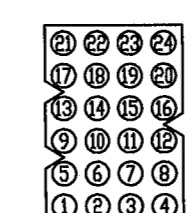

FRONT VIEW OF J1 JACK (SWITCH PANEL)

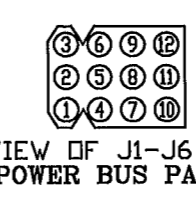

FRONT VIEW OF J1-J6 HARNESSES (POWER BUS PANEL)

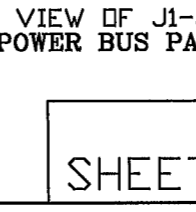

FRONT VIEW OF J1-J6 JACKS (POWER BUS PANEL)

J3	P1
J3-36 → 1	FILTER AC LINE (OUT) P1-1 → SW1-2
MMB-1 → 2	SWITCHED AC LINE (IN) P1-2 → SW1-3
MMA-37 → 3	FLASH CONTROL BUS (OUT) P1-3 → SW2-3
K1-10 → 4	SIGNAL BUS CONTROL (IN) P1-4 → SW5-5
FR6-2 → 5	FLASH RELAY CONTROL (IN) P1-5 → SW5-2
MMB-2 → 6	START DELAY AC BUS (IN) P1-6 → SW1-3
MMA-20 → 7	MMU FLASH CONTROL BUS (IN) P1-7 → SW1-3
→ 8	SPARE P1-8 → ----
→ 9	SPARE P1-9 → ----
→ 10	SPARE P1-10 → ----
→ 11	SPARE P1-11 → ----
→ 12	SPARE P1-12 → ----
A-39 → 13	OPT-MANUAL CONT. ENABLE (IN) P1-13 → ----
A-35 → 14	LOGIC GROUND P1-14 → SW3-1
A-40 → 15	OPT-INTERVAL ADVANCE (IN) P1-15 → ----
A-31 → 16	MMU STOP TIME (OUT) P1-16 → SW3-3
A-30 → 17	CONTROLLER STOP TIME (IN) P1-17 → SW3-2
A-32 → 18	LOCAL FLASH STATUS (IN) P1-18 → SW2-5
A-38 → 19	OPT-COORD FREE (IN) P1-19 → ----
A-33 → 20	OPT-ALARM 1 (IN) P1-20 → ----
A-34 → 21	OPT-ALARM 2 (IN) P1-21 → ----
K1-9 → 22	OPT-LOADSWITCH TEST (IN) P1-22 → ----
B-3 → 23	MMU 24V MON. 2 (IN) P1-23 → ----
B-4 → 24	+24 VDC P1-24 → ----

J3	J1
A-35 → 25	LOGIC GROUND J1-1 → TB1-1
K1-11 → 26	+24 VDC (IN) J1-2 → TB1-2
→ 27	---- J1-3 → TB1-3
B-5 → 28	MMU FAULT MONITOR (IN) J1-4 → TB1-4
J1-31B → 29	LINE FREQ. REFERENCE (IN) J1-5 → TB1-5
→ 30	---- J1-6 → TB1-6
J1-27B → 31	+12 VAC (IN) J1-7 → TB1-7
K1-10 → 32	SIGNAL BUS CONTROL (IN) J1-8 → TB1-8
→ 33	---- J1-9 → TB1-9
K1-2 → 34	FILTERED AC NEUTRAL (IN) J1-10 → TB1-10
MMB-18 → 35	CONT. EQUIP. AC LINE (OUT) J1-11 → TB1-11
J3-1 → 36	FILTERED AC LINE (IN) J1-12 → TB1-12

POWER/AUX PANEL (PAP) 34830G5

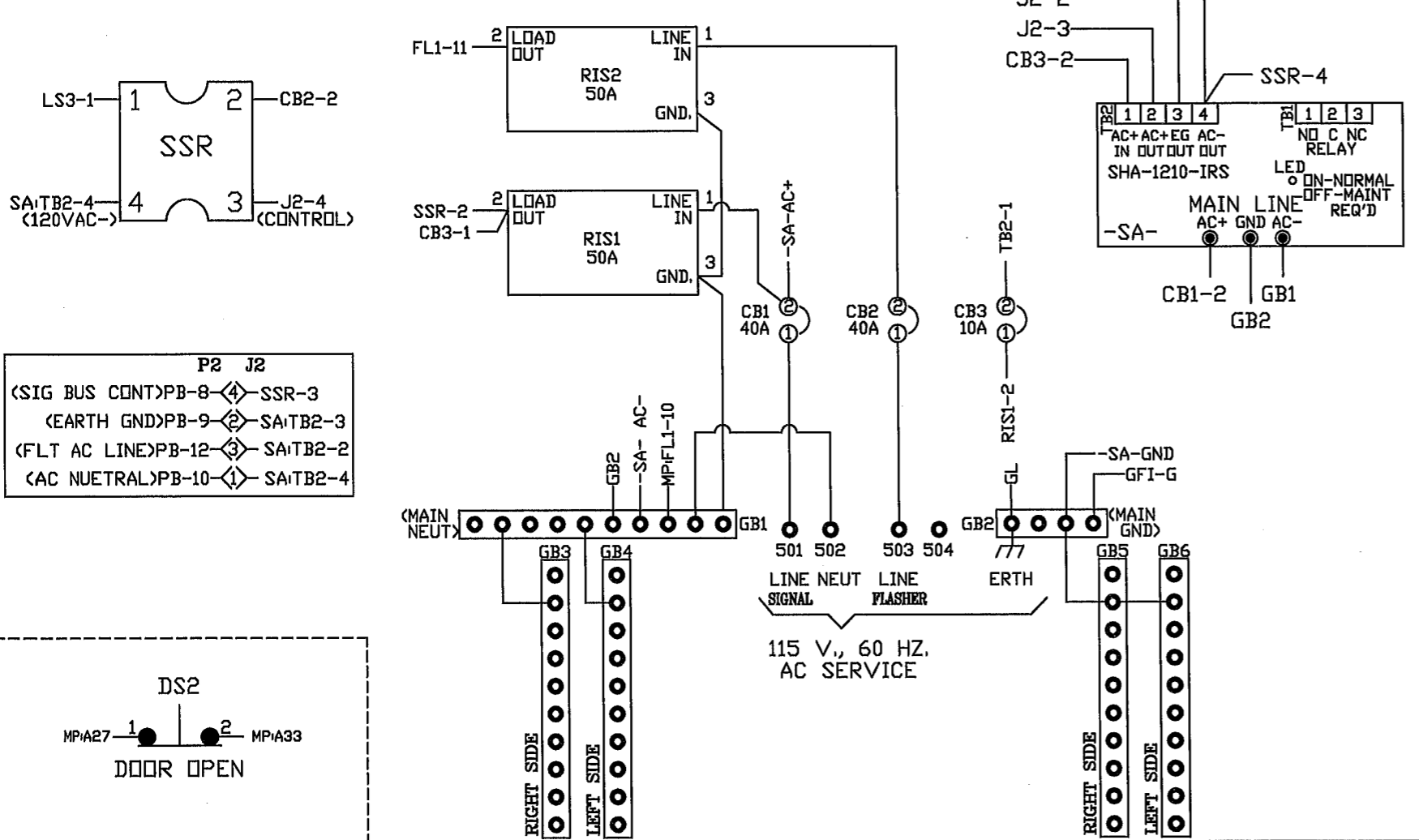

2.2K
10W

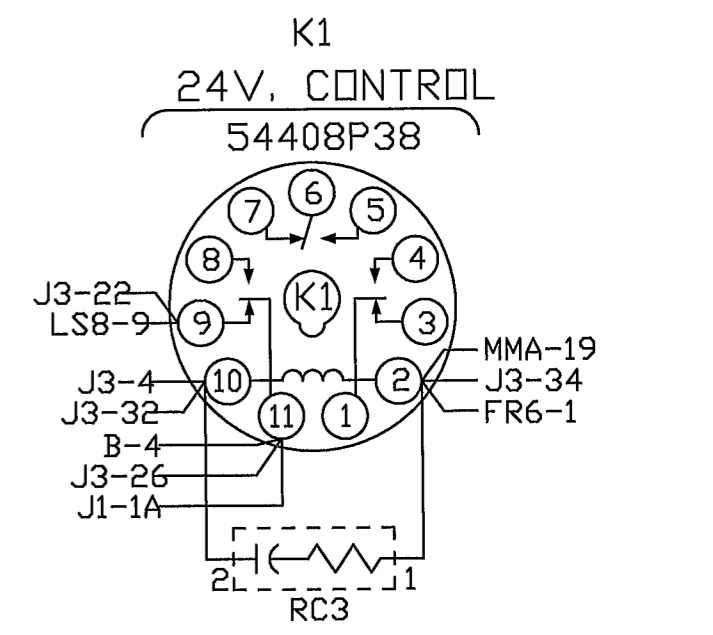
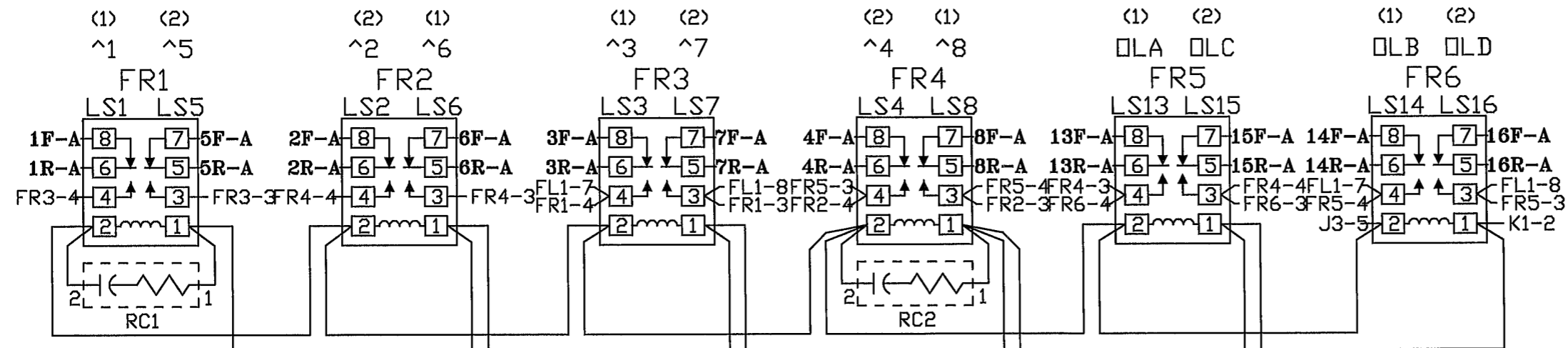
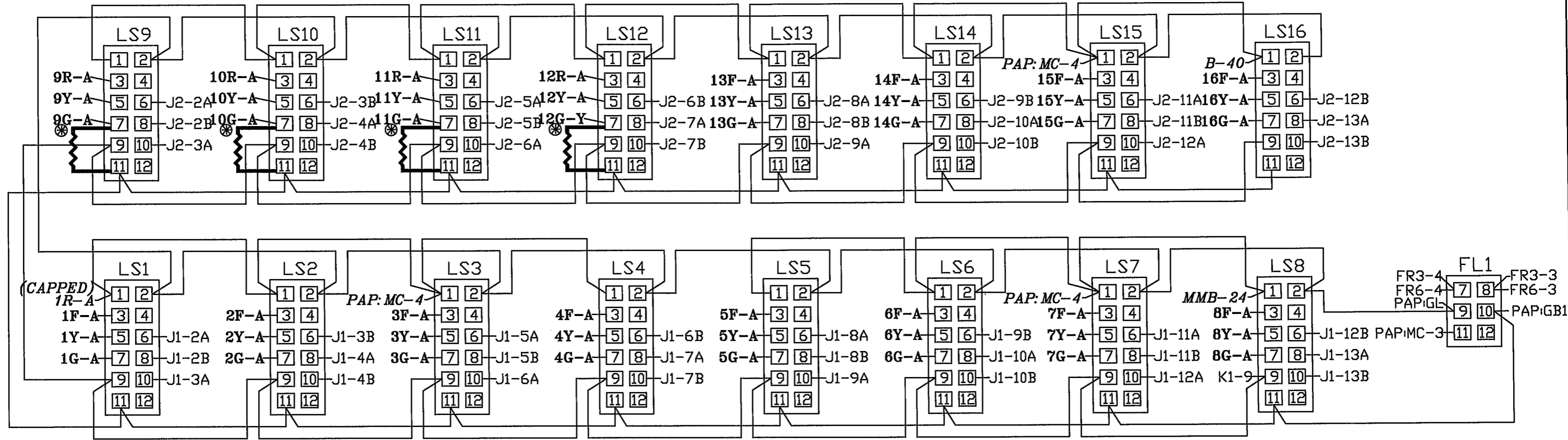

BIU #1			BIU #2		
PIN	FUNCTION	TD	PIN	FUNCTION	TD
1A	+24 VDC	K1-11	1A	+24 VDC	J2-1B
1B	+24 VDC	J2-1B	1B	+24 VDC	J1-1B
2A	LS1 RED	LS1-6	2A	LS9 RED	LS9-6
2B	LS1 YELLOW	LS1-8	2B	LS9 YELLOW	LS9-8
3A	LS1 GREEN	LS1-10	3A	LS9 GREEN	LS9-10
3B	LS2 RED	LS2-6	3B	LS10 RED	LS10-6
4A	LS2 YELLOW	LS2-8	4A	LS10 YELLOW	LS10-8
4B	LS2 GREEN	LS2-10	4B	LS10 GREEN	LS10-10
5A	LS3 RED	LS3-6	5A	LS11 RED	LS11-6
5B	LS3 YELLOW	LS3-8	5B	LS11 YELLOW	LS11-8
6A	LS3 GREEN	LS3-10	6A	LS11 GREEN	LS11-10
6B	LS4 RED	LS4-6	6B	LS12 RED	LS12-6
7A	LS4 YELLOW	LS4-8	7A	LS12 YELLOW	LS12-8
7B	LS4 GREEN	LS4-10	7B	LS12 GREEN	LS12-10
8A	LS5 RED	LS5-6	8A	LS13 RED	LS13-6
8B	LS5 YELLOW	LS5-8	8B	LS13 YELLOW	LS13-8
9A	LS5 GREEN	LS5-10	9A	LS13 GREEN	LS13-10
9B	LS6 RED	LS6-6	9B	LS14 RED	LS14-6
10A	LS6 YELLOW	LS6-8	10A	LS14 YELLOW	LS14-8
10B	LS6 GREEN	LS6-10	10B	LS14 GREEN	LS14-10
11A	LS7 RED	LS7-6	11A	LS15 RED	LS15-6
11B	LS7 YELLOW	LS7-8	11B	LS15 YELLOW	LS15-8
12A	LS7 GREEN	LS7-10	12A	LS15 GREEN	LS15-10
12B	LS8 RED	LS8-6	12B	LS16 RED	LS16-6
13A	LS8 YELLOW	LS8-8	13A	LS16 YELLOW	LS16-8
13B	LS8 GREEN	LS8-10	13B	LS16 GREEN	LS16-10
14A	TBC AUX 1	A-16	14A	TBC AUX 3	A-18
14B	TBC AUX 2	A-17	14B	COORD. STATUS	A-19
15A	PMT ACT 1	A-21	15A	PMT ACT 3	A-23
15B	PMT ACT 2	A-22	15B	PMT ACT 4	A-24
16A	PMT CALL 1	B-15	16A	PMT ACT 5	A-25
16B	PMT CALL 2	B-16	16B	PMT ACT 6	A-26
17A	TEST A	A-12	17A	PMT CALL 3	B-17
17B	TEST B	A-13	17B	PMT CALL 4	B-18
18A	AUTO FLASH	A-37	18A	PMT CALL 5	B-19
18B	DIM. ENABLE	A-36	18B	PMT CALL 6	B-20
19A	MANUAL CONT.	A-39	19A	CNA 2	A-8
19B	INT. ADVANCE	A-40	19B	SPARE 1	B-10
20A	EXT. MIN. RECALL	A-10	20A	SPARE 2	B-11
20B	EXT. START	A-11	20B	SPARE 3	B-12
21A	TBC ONLINE	A-15	21A	SPARE 4	B-13
21B	STOP TIME (1)	A-30	21B	INHIBIT MAX (1)	A-1
22A	STOP TIME (2)	A-30	22A	INHIBIT MAX (2)	A-2
22B	MAX. 2 (1)	A-5	22B	LOCAL FLASH	A-32
23A	MAX. 2 (2)	A-6	23A	MMU FLASH	A-31
23B	FORCE OFF (1)	A-3	23B	ALARM 1	A-33
24A	FORCE OFF (2)	A-4	24A	ALARM 2	A-34
24B	CNA 1	A-7	24B	COORD FREE IN	A-38
25A	WALK REST MOD.	A-9	25A	TEST C	A-14
25B	PED. ISD. 1	B-6	25B	PED. ISD. 5	B-8
26A	PED. ISD. 2	PC2-A	26A	PED. ISD. 6	PC6-A
26B	PED. ISD. 3	B-7	26B	PED. ISD. 7	B-9
27A	PED. ISD. 4	PC4-A	27A	PED. ISD. 8	PC8-A
27B	PED. ISD. COMN.	J3-31	27B	PED. ISD. COMN.	J1-27B
28A	ADDR. SEL. 0	-----	28A	ADDR. SEL. 0	J2-32A
28B	ADDR. SEL. 1	-----	28B	ADDR. SEL. 1	-----
29A	ADDR. SEL. 2	-----	29A	ADDR. SEL. 2	-----
29B	ADDR. SEL. 3	-----	29B	ADDR. SEL. 3	-----
30A	RESERVED	-----	30A	RESERVED	-----
30B	RESERVED	-----	30B	RESERVED	-----
31A	EARTH GND.	LS12-2	31A	EARTH GND.	J1-31A
31B	LINE FREQ. REF.	J3-29	31B	LINE FREQ. REF.	J1-31B
32A	LOGIC GND.	B-14	32A	LOGIC GND.	J1-32B
32B	LOGIC GND.	J2-32A	32B	LOGIC GND.	J2-32A

MAIN PANEL CONTROL POWER C/C 34842G4	
PIN	FUNCTION
1	LOGIC GROUND
2	+24 VDC (IN)
3	-----
4	MMU FAULT MONITOR (IN)
5	LINE FREQ. REFERENCE (IN)
6	-----
7	+12 VAC (IN)
8	SIGNAL BUS CONTROL (IN)
9	-----
10	FILTERED AC NEUTRAL (IN)
11	CONT. EQUIP. AC LINE (OUT)
12	FILTERED AC LINE (IN)

CONTROLLER POWER (CCA2) C/C 34842G3			
WIRE	PIN	SIGNAL	TD
1	A	FAULT MONITOR	PB-4
2	U	AC NEUTRAL	PB-10
3	V	EARTH GROUND	PB-9
4	W	LOGIC GROUND	PB-1
5	P	AC LINE	PB-11
6	SHL	EARTH GROUND	CCA2-V

TYPE 1 CONTROLLER POWER C/C 34842G2		
PIN	FUNCTION	TD
A	AC NEUTRAL	PB-10
B	-----	-----
C	AC LINE	PB-11
D	-----	-----
E	+12 VDC	PB-3
F	+24 VDC	PB-2
G	RESERVED	-----
H	LOGIC GND.	PB-1
I	EARTH GND.	PB-9
J	+12 VAC	PB-7
K	RESERVED	-----
SHL	EARTH GND.	PIN H

CABINET POWER SUPPLY C/C 34842G1		
PIN	FUNCTION	TD
A	AC NEUTRAL	PB-10
B	LINE FREQUENCY REF.	PB-5
C	AC LINE	PB-11
D	+12 VDC	PB-3
E	+24 VDC	PB-2
F	RESERVED	-----
G	LOGIC GND.	PB-1
H	EARTH GND.	PB-9
I	+12 VAC	PB-7
J	RESERVED	-----
SHL	EARTH GND.	PIN H

CONTROLLER PORT 1 CONNECTOR			
PIN	SIGNAL	TD	FUNCTION
1	TWISTED PAIR 1+	SDLC-1	CONT TXD+
2	LOGIC GND.	-----	-----
3	TWISTED PAIR 2+	SDLC-4	CONT TXC+
4	LOGIC GND.	-----	-----
5	TWISTED PAIR 3+	SDLC-7	CONT RXD+
6	LOGIC GND.	-----	-----
7	TWISTED PAIR 4+	SDLC-10	CONT RXC+
8	LOGIC GND.	-----	-----
9	TWISTED PAIR 1-	SDLC-2	CONT TXD-
10	PORT 1 DISABLE	-----	-----
11	TWISTED PAIR 2-	SDLC-5	CONT TXC-
12	EARTH GND.	SHIELD WIRE	-----
13	TWISTED PAIR 3-	SDLC-8	CONT RXD-
14	RESERVED	-----	-----
15	TWISTED PAIR 4-	SDLC-11	CONT RXC-

MMU & BIU PORT 1 CONNECTOR			
PIN	SIGNAL	TD	FUNCTION
1	TWISTED PAIR 1+	SDLC-1	BIU RXD+
2	LOGIC GND.	-----	-----
3	TWISTED PAIR 2+	SDLC-4	BIU RXC+
4	LOGIC GND.	-----	-----
5	TWISTED PAIR 3+	SDLC-7	BIU TXD+
6	LOGIC GND.	-----	-----
7	TWISTED PAIR 4+	SDLC-10	BIU TXC+
8	LOGIC GND.	-----	-----
9	TWISTED PAIR 1-	SDLC-2	BIU RXD-
10	PORT 1 DISABLE	-----	-----
11	TWISTED PAIR 2-	SDLC-5	BIU RXC-
12	EARTH GND.	SHIELD WIRE	-----
13	TWISTED PAIR 3-	SDLC-8	BIU TXD-
14	RESERVED	-----	-----
15	TWISTED PAIR 4-	SDLC-11	BIU TXC-

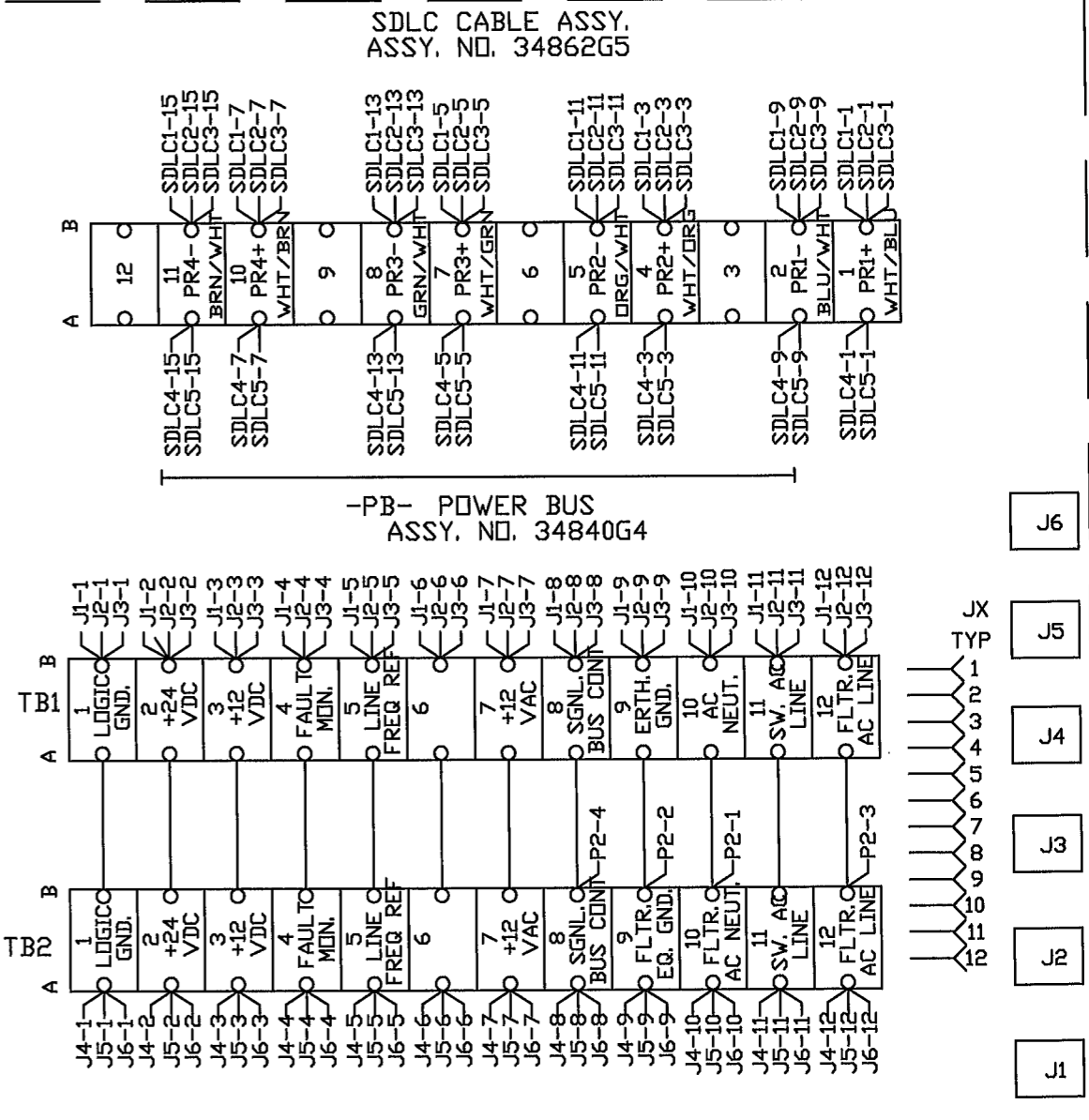
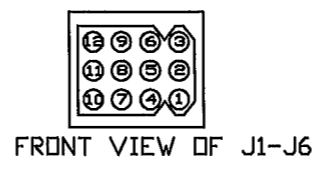
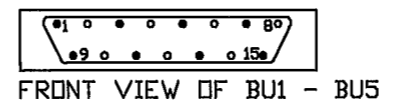

WIRE LIST FOR NEMA MALFUNCTION MANAGEMENT UNIT

CONNECTOR "A" (MMA)				CONNECTOR "B" (MMB)							
PIN	WIRE	MON. FUNCTION	SIG. FUNCTION	PIN	WIRE	MON. FUNCTION	SIG. FUNCTION				
A	A-1	AC+ I INPUT	B21	A	B-1	AC+ II INPUT	J3-2 MMU POWER				
B	A-2	OUT RLY 1 OPEN	B22	B	B-2	S. DLY RLY COMM.	J3-6 MMU POWER				
C	A-3	OUT RLY 2 CLSD	B23	C	B-3	S. DLY RLY OPEN	B28				
D	A-4	CH. 12 GREEN	12G-A ^8 WLK	D	B-4	CH. 12 RED	B40				
E	A-5	CH. 11 GREEN	11G-A ^6 WLK	E	B-5	CH. 11 RED	B39				
F	A-6	CH. 10 GREEN	10G-A ^4 WLK	F	B-6	CH. 9 RED	B37				
G	A-7	CH. 9 GREEN	9G-A ^2 WLK	G	B-7	CH. 8 RED	8R-A ^8 RED				
H	A-8	CH. 8 GREEN	8G-A ^8 GRN	H	B-8	CH. 7 RED	7R-A ^7 RED				
J	A-9	CH. 7 GREEN	7G-A ^7 GRN	J	B-9	CH. 6 RED	6R-A ^6 RED				
K	A-10	CH. 6 GREEN	6G-A ^6 GRN	K	B-10	CH. 5 RED	5R-A ^5 RED				
L	A-11	CH. 5 GREEN	5G-A ^5 GRN	L	B-11	CH. 4 RED	4R-A ^4 RED				
M	A-12	CH. 4 GREEN	4G-A ^4 GRN	M	B-12	CH. 2 RED	2R-A ^2 RED				
N	A-13	CH. 3 GREEN	3G-A ^3 GRN	N	B-13	CH. 1 RED	1R-A ^1 RED				
P	A-14	CH. 2 GREEN	2G-A ^2 GRN	P	B-14	(SPARE 1)	B29				
R	A-15	CH. 1 GREEN	1G-A ^1 GRN	R	B-15	+24V MONITOR II	B-3 +24V MON. II				
S	A-16	+24V MON. I	B-4 LS +24V MON.	S	B-16	(SPARE 2)	B30				
T	A-17	LOGIC GND	B-14 LOGIC GND	T	B-17	CH. 13 RED	13R-A OLA RED				
U	A-18	CHASSIS GND	LS7-2 EARTH GND.	U	B-18	S. DLY RLY CLSD	J3-35 CONT. POWER				
V	A-19	AC- (COMMON)	K1-2 AC NEUTRAL	V	B-19	CH. 10 RED	B38				
W	A-20	OUT RLY 1 COM.	J3-7 SIG BUS CONT	W	B-20	CH. 14 RED	14R-A OLB RED				
X	A-21	OUT RLY 2 COM.	A-27 LOGIC GND	X	B-21	CH. 15 RED	15R-A OLC RED				
Y	A-22	CH. 12 YELLOW	-T-	Y	B-22	CH. 16 RED	16R-A OLD RED				
Z	A-23	CH. 11 YELLOW	-T-	Z	B-23	CH. 3 RED	3R-A ^3 RED				
a	A-24	CH. 10 WALK	----	a	B-24	RED ENABLE	LS8-1 SIG BUS CON.				
b	A-25	CH. 10 YELLOW	-T-	b	B-25	(SPARE 3)	B31				
c	A-26	CH. 9 YELLOW	-T-	c	B-26	LOCAL FLASH IN	CAPPED POL/AX FLSH				
d	A-27	CH. 8 YELLOW	8Y-A ^8 YEL		B-27	SHELL GROUND	LS6-2 EARTH GND.				
e	A-28	CH. 7 YELLOW	7Y-A ^7 YEL	NOTES FOR 16 CHANNEL M.M.U. (1) RELAY CONTACT POSITIONS SPECIFIED ARE FOR NON-CONFLICT MODE. (2) TO PROGRAM MMU, SOLDER JUMPERS IN PROGRAMMING CARD FOR ALL PERMISSABLE PHASE MOVEMENTS, MINIMUM CHANGE DIS-ABLE FOR ALL PEDESTRIAN CHANNELS, AND MIN. FLASH, VOLTAGE MON., AND 24V. MON. LATCH OPTIONS AS DESIRED. M.M.U. CHANNEL ASSIGNMENTS CH. 1 = L/S 1 = ^1 VEH. CH. 2 = L/S 2 = ^2 VEH. CH. 3 = L/S 3 = ^3 VEH. CH. 4 = L/S 4 = ^4 VEH. CH. 5 = L/S 5 = ^5 VEH. CH. 6 = L/S 6 = ^6 VEH. CH. 7 = L/S 7 = ^7 VEH. CH. 8 = L/S 8 = ^8 VEH. CH. 9 = L/S 9 = ^2 PED. CH. 10 = L/S 10 = ^4 PED. CH. 11 = L/S 11 = ^6 PED. CH. 12 = L/S 12 = ^8 PED. CH. 13 = L/S 13 = OLAP A CH. 14 = L/S 14 = OLAP B CH. 15 = L/S 15 = OLAP C CH. 16 = L/S 16 = OLAP D							
f	A-29	CH. 6 YELLOW	6Y-A ^6 YEL								
g	A-30	CH. 5 YELLOW	5Y-A ^5 YEL								
h	A-31	CH. 3 YELLOW	3Y-A ^3 YEL								
i	A-32	CH. 15 GREEN	15G-A OLC GRN								
j	A-33	CH. 2 YELLOW	2Y-A ^2 YEL								
k	A-34	CH. 1 YELLOW	1Y-A ^1 YEL								
m	A-35	CONT. VOLT. MON.	B-5 VOLT. MON.								
n	A-36	+24V MON. INH.	B-2								
p	A-37	OUT RLY 1 CLSD	J3-3								
q	A-38	OUT RLY 2 OPEN	A-31 STOP TIME								
r	A-39	CH. 12 WALK	----								
s	A-40	CH. 11 WALK	----								
t	A-41	CH. 9 WALK	----								
u	A-42	CH. 16 YELLOW	16Y-A OLD YEL								
v	A-43	CH. 15 YELLOW	15Y-A OLC YEL								
w	A-44	CH. 13 YELLOW	13Y-A OLA YEL								
x	A-45	CH. 4 YELLOW	4Y-A ^4 YEL								
y	A-46	CH. 14 GREEN	14G-A OLB GRN								
z	A-47	CH. 13 GREEN	13G-A OLA GRN								
AA	A-48	(SPARE 1)	B24								
BB	A-49	RESET	B-1								
CC	A-50	CAB. INTLK A	B25								
DD	A-51	CAB. INTLK B	B26								
EE	A-52	CH. 14 YELLOW	14Y-A OLB YRL								
FF	A-53	CH. 16 GREEN	16G-A OLD GRN								
GG	A-54	(SPARE 2)	B27								
HH	A-55	TYPE SELECT	A-20 MMU/CMU SEL.								
	A-56	SHELL GND	LS15-2 EARTH GND.								

MMU PROGRAM CARD

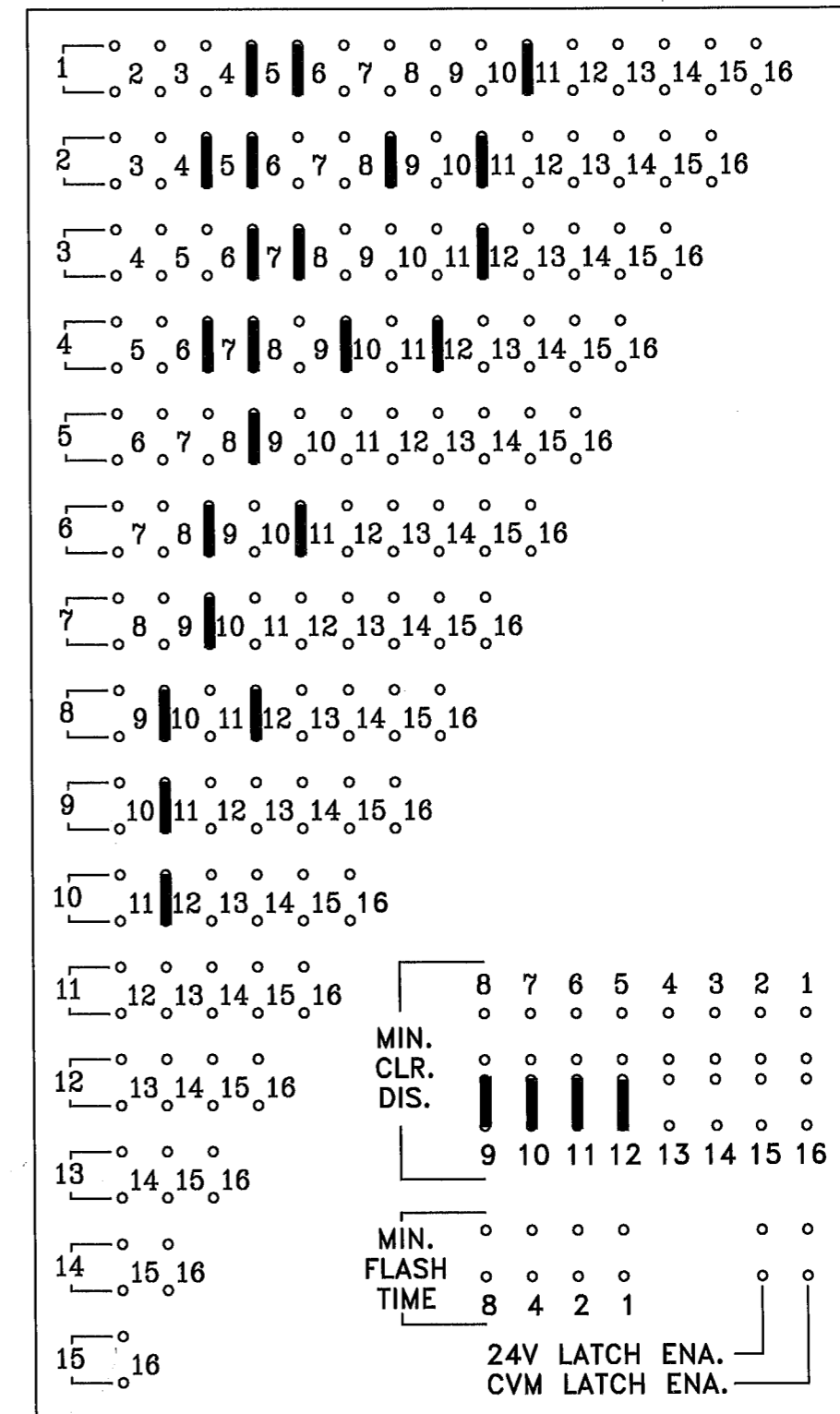

M.M.U. C/C'S AND PROGRAM CARD

DETECTOR RACK 34030G1

POWER SUPPLY OR B.I.U.	L3	L1	L7	L5	L11	L9	L15	L13	PMT 5 3-8	PMT 3 1-6	PGM. CARD
	5-1	1-1	6-1	2-1	7-1	3-1	∅	4-1	<input type="checkbox"/> 2CH OPTICOM/ OPIC CH. C CH. D 4-7	<input type="checkbox"/> 4CH <input type="checkbox"/> 2CH OPTICOM/ OPIC CH. A CH. B 2-5	
	<input type="checkbox"/> 2CH 5-2	<input type="checkbox"/> 2CH 1-2	<input type="checkbox"/> 2CH 6-2	<input type="checkbox"/> 2CH 2-2	<input type="checkbox"/> 2CH 7-2	<input type="checkbox"/> 2CH 3-2	<input type="checkbox"/> 2CH ∅	<input type="checkbox"/> 2CH 4-2			
	L4	L2	L8	L6	L12	L10	L16	L14	PMT 6	PMT 4	

J13 C/C 33284G10 DC POWER	J16 C/C 33284G8 EXP. OUTPUTS	J14 C/C 33284G2 LPS 1-8	J18 C/C 33284G9 SYS. OUTPUTS	J15 C/C 33284G3 LPS 9-16	J17 C/C 33284G6 AC POWER	J19 C/C 33284G17 PGM. CARD
--	---	--------------------------------------	---	---------------------------------------	---------------------------------------	---

①

ADDRESS TABLE					
RACK #	JMPR	DET. #'S	RACK #	JMPR	DET. #'S
1	<input type="checkbox"/> <input type="checkbox"/> <input type="checkbox"/>	1-16	5	<input type="checkbox"/> <input type="checkbox"/> <input type="checkbox"/>	65-80
2	<input type="checkbox"/> <input type="checkbox"/> <input type="checkbox"/>	17-32	6	<input type="checkbox"/> <input type="checkbox"/> <input type="checkbox"/>	81-96
3	<input type="checkbox"/> <input type="checkbox"/> <input type="checkbox"/>	33-48	7	<input type="checkbox"/> <input type="checkbox"/> <input type="checkbox"/>	97-112
4	<input type="checkbox"/> <input type="checkbox"/> <input type="checkbox"/>	49-64	8	<input type="checkbox"/> <input type="checkbox"/> <input type="checkbox"/>	113-128

DETECTOR ASSIGNMENTS		
CONT. INPUT	PHASE ASGN.	DETECTOR TYPE
1	1-1	1
2	1-2	1
3	5-1	1
4	5-2	1
5	2-1	1
6	2-2	1
7	6-1	1
8	6-2	1
9	3-1	1
10	3-2	1
11	7-1	1
12	7-2	1
13	4-1	1
14	4-2	1
15		
16		
17	8-1	1
18	8-2	1
19	8-3	1
20		
21		
22		
23		
24		
25		
26		
27		
28		
29		
30		
31		
32		
33		
34		
35		
36		

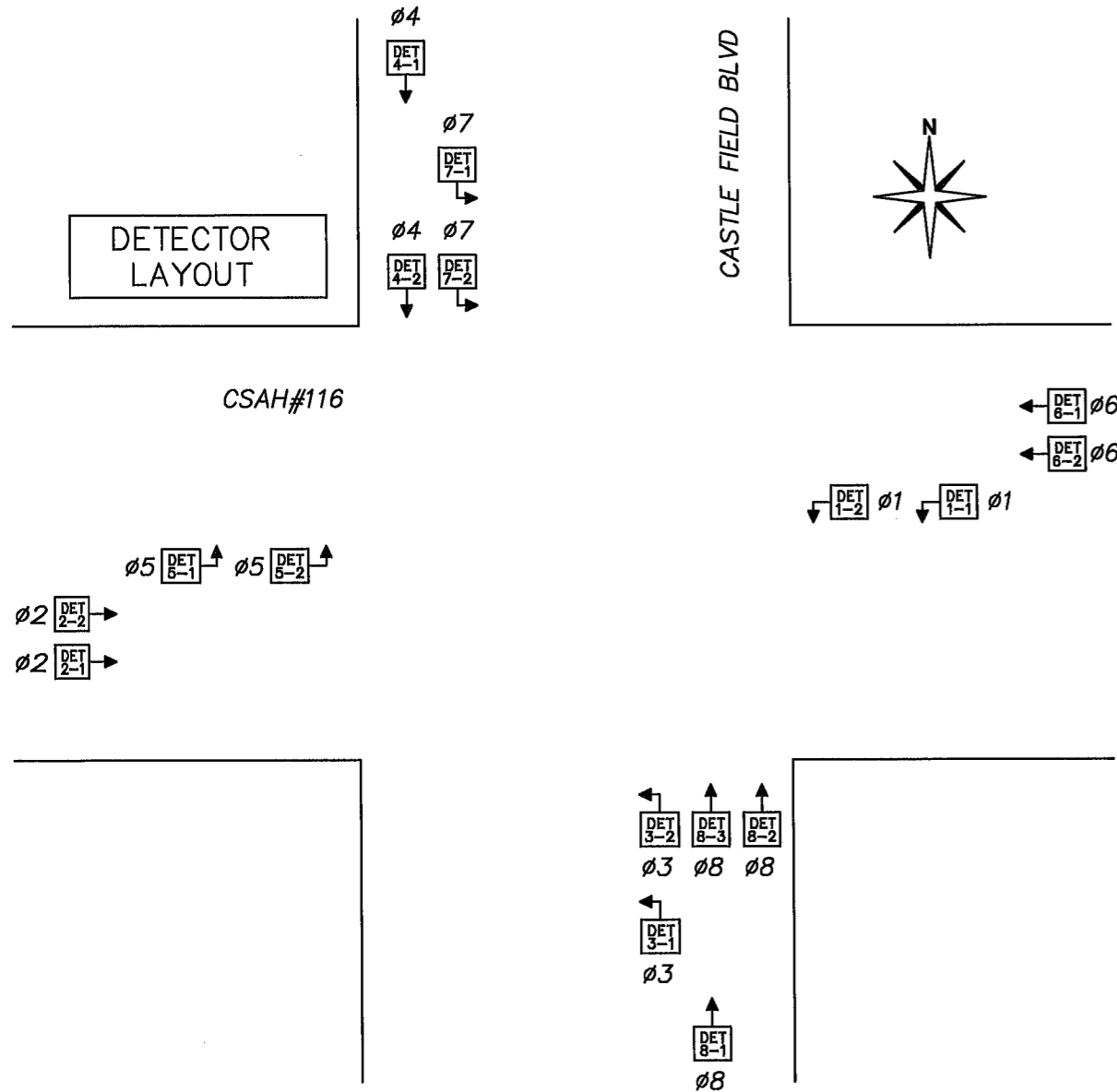

DET. TYPE		DETECTOR RACK PROGRAMMING JUMPERS																													
		SLOT 1/2 ①						SLOT 3/4 ①						SLOT 5/6 ①						SLOT 7/8 ①											
JP1	JP2	JP3	JP4	JP5	JP6	JP7	JP8	JP9	JP10	JP11	JP12	JP13	JP14	JP15	JP16	JP17	JP18	JP19	JP20	JP21	JP22	JP23	JP24	JP25	JP26	JP27	JP28	JP29	JP30		
①	TS-1	NO	NO	<input type="checkbox"/>	<input type="checkbox"/>	<input type="checkbox"/>	<input type="checkbox"/>	<input type="checkbox"/>	<input type="checkbox"/>	<input type="checkbox"/>	<input type="checkbox"/>	<input type="checkbox"/>	<input type="checkbox"/>	<input type="checkbox"/>	<input type="checkbox"/>	<input type="checkbox"/>	<input type="checkbox"/>	<input type="checkbox"/>	<input type="checkbox"/>	<input type="checkbox"/>	<input type="checkbox"/>	<input type="checkbox"/>	<input type="checkbox"/>	<input type="checkbox"/>	<input type="checkbox"/>	<input type="checkbox"/>	<input type="checkbox"/>	<input type="checkbox"/>	<input type="checkbox"/>		
②	TS-2	YES	YES	<input type="checkbox"/>	<input type="checkbox"/>	<input type="checkbox"/>	<input type="checkbox"/>	<input type="checkbox"/>	<input type="checkbox"/>	<input type="checkbox"/>	<input type="checkbox"/>	<input type="checkbox"/>	<input type="checkbox"/>	<input type="checkbox"/>	<input type="checkbox"/>	<input type="checkbox"/>	<input type="checkbox"/>	<input type="checkbox"/>	<input type="checkbox"/>	<input type="checkbox"/>	<input type="checkbox"/>	<input type="checkbox"/>	<input type="checkbox"/>	<input type="checkbox"/>	<input type="checkbox"/>	<input type="checkbox"/>	<input type="checkbox"/>	<input type="checkbox"/>	<input type="checkbox"/>		
③	M-632T 262-FC	NO	NO	<input type="checkbox"/>	<input type="checkbox"/>	<input type="checkbox"/>	<input type="checkbox"/>	<input type="checkbox"/>	<input type="checkbox"/>	<input type="checkbox"/>	<input type="checkbox"/>	<input type="checkbox"/>	<input type="checkbox"/>	<input type="checkbox"/>	<input type="checkbox"/>	<input type="checkbox"/>	<input type="checkbox"/>	<input type="checkbox"/>	<input type="checkbox"/>	<input type="checkbox"/>	<input type="checkbox"/>	<input type="checkbox"/>	<input type="checkbox"/>	<input type="checkbox"/>	<input type="checkbox"/>	<input type="checkbox"/>	<input type="checkbox"/>	<input type="checkbox"/>	<input type="checkbox"/>		
④	MAG.	NO	NO	<input type="checkbox"/>	<input type="checkbox"/>	<input type="checkbox"/>	<input type="checkbox"/>	<input type="checkbox"/>	<input type="checkbox"/>	<input type="checkbox"/>	<input type="checkbox"/>	<input type="checkbox"/>	<input type="checkbox"/>	<input type="checkbox"/>	<input type="checkbox"/>	<input type="checkbox"/>	<input type="checkbox"/>	<input type="checkbox"/>	<input type="checkbox"/>	<input type="checkbox"/>	<input type="checkbox"/>	<input type="checkbox"/>	<input type="checkbox"/>	<input type="checkbox"/>	<input type="checkbox"/>	<input type="checkbox"/>	<input type="checkbox"/>	<input type="checkbox"/>	<input type="checkbox"/>		

DETECTOR LOOP
INTERFACE
ASSY. 34040G1

J1
TO DR1: J14
C/C 33284G2

J2
TO DR1: J15
C/C 33284G3

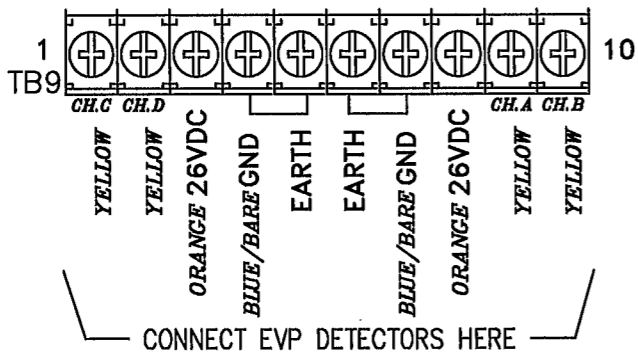
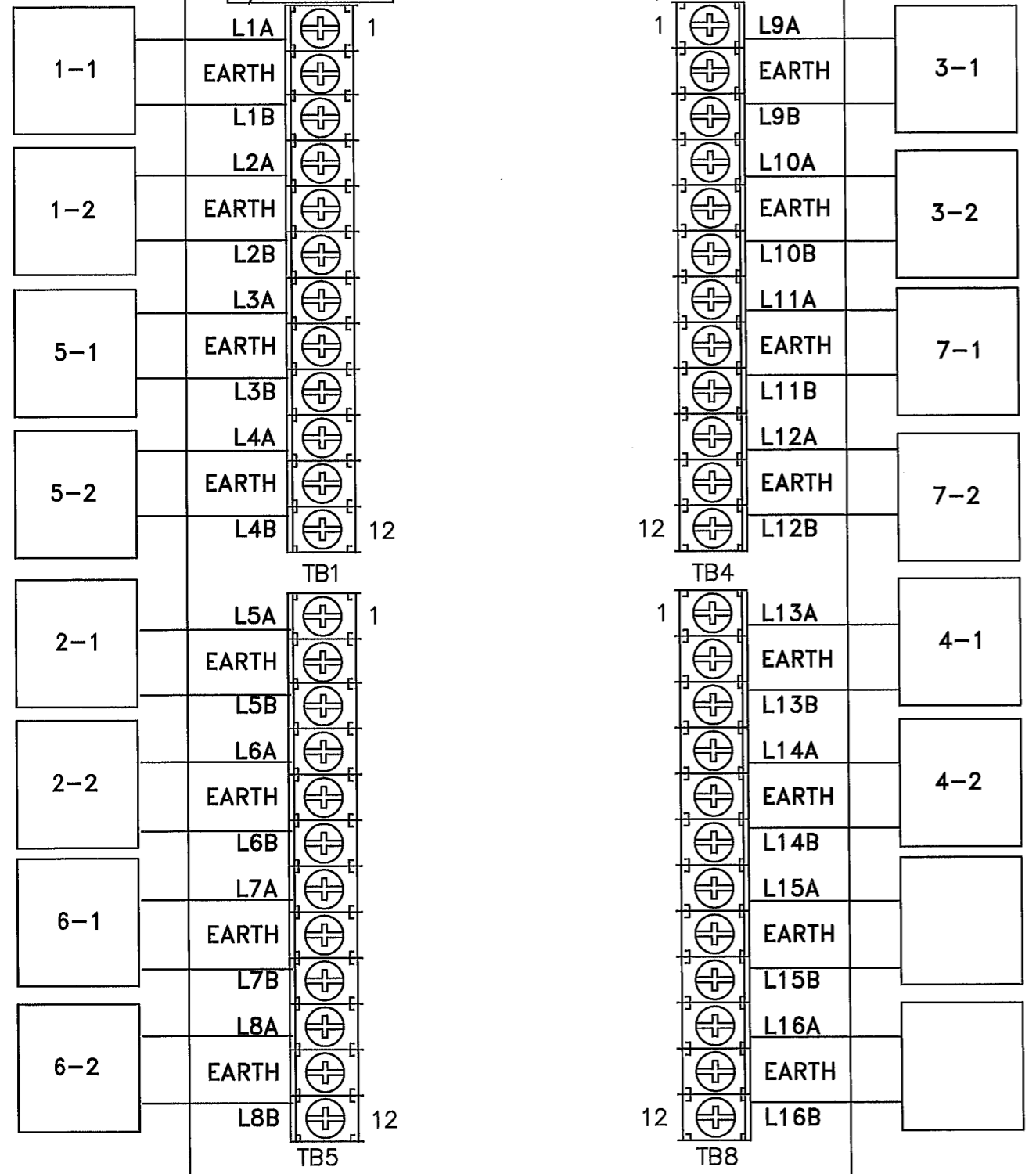

DET. LOOPS 9-16 (J15) C/C 33284G3

PIN	SIGNAL	TO
1	LOOP 9+	LPI2: TB4-1
2	LOOP 9-	LPI2: TB4-3
3	LOOP 10+	LPI2: TB4-4
4	LOOP 10-	LPI2: TB4-6
5	LOOP 11+	LPI2: TB4-7
6	LOOP 11-	LPI2: TB4-9
7	LOOP 12+	LPI2: TB4-10
8	LOOP 12-	LPI2: TB4-12
9	LOOP 13+	LPI2: TB8-1
10	LOOP 13-	LPI2: TB8-3
11	LOOP 14+	LPI2: TB8-4
12	LOOP 14-	LPI2: TB8-6
13	LOOP 15+	LPI2: TB8-7
14	LOOP 15-	LPI2: TB8-9
15	LOOP 16+	LPI2: TB8-10
16	LOOP 16-	LPI2: TB8-12
17	----	
18	----	
19	----	
20	----	

DET. LOOPS 1-8 (J14) C/C 33284G2

PIN	SIGNAL	TO
1	LOOP 1+	LPI1: TB1-1
2	LOOP 1-	LPI1: TB1-3
3	LOOP 2+	LPI1: TB1-4
4	LOOP 2-	LPI1: TB1-6
5	LOOP 3+	LPI1: TB1-7
6	LOOP 3-	LPI1: TB1-9
7	LOOP 4+	LPI1: TB1-10
8	LOOP 4-	LPI1: TB1-12
9	LOOP 5+	LPI1: TB5-1
10	LOOP 5-	LPI1: TB5-3
11	LOOP 6+	LPI1: TB5-4
12	LOOP 6-	LPI1: TB5-6
13	LOOP 7+	LPI1: TB5-7
14	LOOP 7-	LPI1: TB5-9
15	LOOP 8+	LPI1: TB5-10
16	LOOP 8-	LPI1: TB5-12
17	PMT. DET. CH. C	LPI1: TB9-1
18	PMT. DET. CH. D	LPI1: TB9-2
19	KEY PIN	
20	PMT. CH. C/D +26VDC	LPI1: TB9-3
21	PMT. DC GROUND	LPI1: TB9-4,7
22	PMT. CH. A/B +26VDC	LPI1: TB9-8
23	PMT. DET. CH. A	LPI1: TB9-9
24	PMT. DET. CH. B	LPI1: TB9-10
25	----	
26	----	

DET. RACK POWER
C/C 34842G5

P1/ DR: J13	P2/ DR: J17	FUNCTION	TO
1		+12 VDC (DET. POWER)	PB-3
2		+24 VDC (BIU POWER)	PB-2
3		LOGIC GROUND	PB-1
4		EARTH GROUND	PB-9
5		"KEY PIN"	
6		LINE FREQUENCY REF.	PB-5
	1	EARTH GROUND	----
	2	AC LINE	PB-12
	3	AC NEUTRAL	PB-10
	4	LOGIC GROUND	----

EXPANSION OUTPUTS
C/C 33284G8

J16	FUNCTION	TO
17	DET. 17 / PMT. A OUT	MP: B19
18	DET. 18 / PMT. B OUT	MP: B20
19	PMT. C OUT	MP: B17
20	PMT. D OUT	MP: B18

DETECTOR LOOP INTERFACE

DETECTOR RACK 34030G1

②

POWER SUPPLY OR B.I.U.	L19	L17	L23	L21	L27	L25	L31	L29	PGM. CARD
	8-3	8-1	∅	∅	∅	∅	∅	∅	
	□ 2CH ∅	□ 2CH 8-2	□ 2CH ∅	□ 2CH ∅	□ 2CH ∅	□ 2CH ∅	□ 2CH ∅	□ 2CH ∅	
	L20	L18	L24	L22	L28	L26	L32	L30	

J13 C/C 33284G10 DC POWER	J16 C/C 33284G8 EXP. OUTPUTS	J14 C/C 33284G2 LPS 1-8	J18 C/C 33284G9 SYS. OUTPUTS	J15 C/C 33284G3 LPS 9-16	J17 C/C 33284G6 AC POWER	J19 C/C 33284G17 PGM. CARD
--	---	--------------------------------------	---	---------------------------------------	---------------------------------------	---

ADDRESS TABLE					
RACK #	JMPR	DET. #'S	RACK #	JMPR	DET. #'S
1	□□□□	1-16	5	□□□□	65-80
2	□□□□	17-32	6	□□□□	81-96
3	□□□□	33-48	7	□□□□	97-112
4	□□□□	49-64	8	□□□□	113-128

DETECTOR ASSIGNMENTS		
CONT. INPUT	PHASE ASGN.	DETECTOR TYPE
1	1-1	1
2	1-2	1
3	5-1	1
4	5-2	1
5	2-1	1
6	2-2	1
7	6-1	1
8	6-2	1
9	3-1	1
10	3-2	1
11	7-1	1
12	7-2	1
13	4-1	1
14	4-2	1
15		
16		
17	8-1	1
18	8-2	1
19	8-3	1
20		
21		
22		
23		
24		
25		
26		
27		
28		
29		
30		
31		
32		
33		
34		
35		
36		

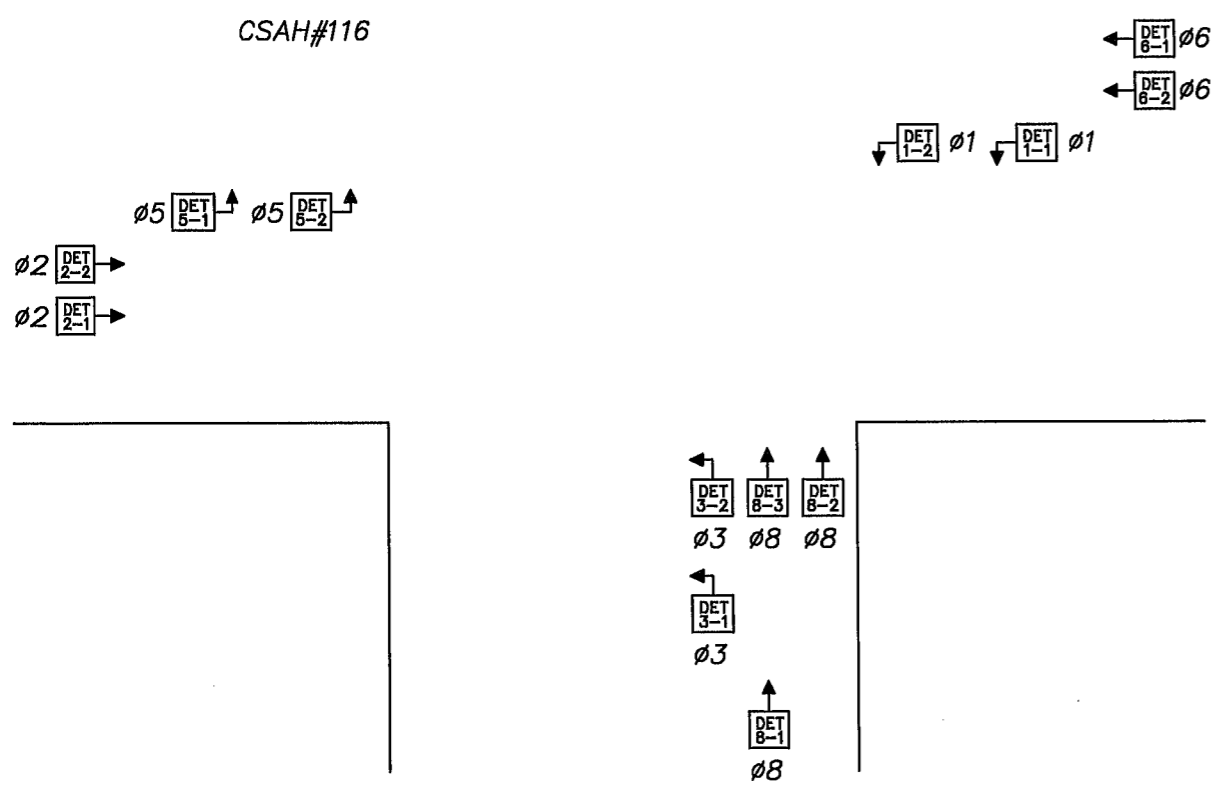
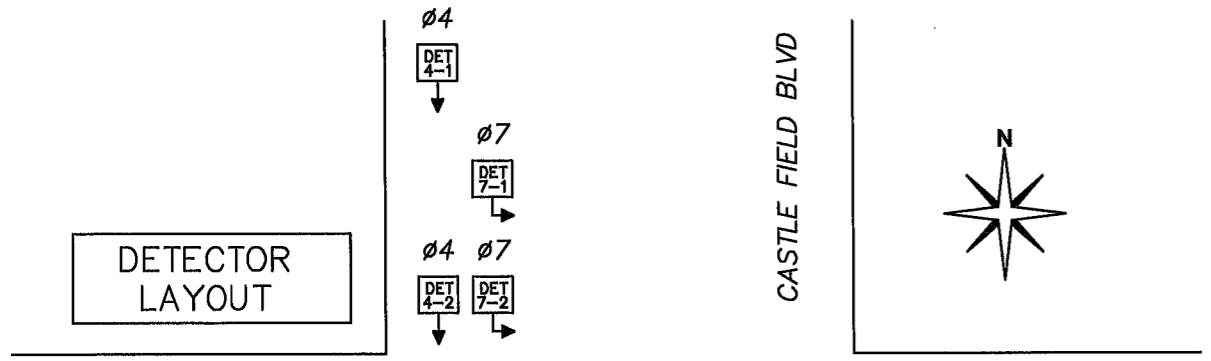

DET. TYPE		DETECTOR RACK PROGRAMMING JUMPERS																															
		SLOT 1/2 ①								SLOT 3/4 ①								SLOT 5/6 ①								SLOT 7/8 ①							
JP1	JP2	JP3	JP4	JP5	JP6	JP7	JP8	JP9	JP10	JP11	JP12	JP13	JP14	JP15	JP16	JP17	JP18	JP19	JP20	JP21	JP22	JP23	JP24	JP25	JP26	JP27	JP28	JP29	JP30				
①	TS-1	NO	NO	○	○	○	○	○	○	○	○	○	○	○	○	○	○	○	○	○	○	○	○	○	○	○	○	○	○				
②	TS-2	YES	YES	○	○	○	○	○	○	○	○	○	○	○	○	○	○	○	○	○	○	○	○	○	○	○	○	○	○				
③	M-632T 262-FC	NO	NO	○	○	○	○	○	○	○	○	○	○	○	○	○	○	○	○	○	○	○	○	○	○	○	○	○	○				
④	MAG.	NO	NO	○	○	○	○	○	○	○	○	○	○	○	○	○	○	○	○	○	○	○	○	○	○	○	○	○	○				

DETECTOR LOOP
INTERFACE
ASSY. 34040G1

J1
TO DR1: J14
C/C 33284G2

J2
TO DR1: J15
C/C 33284G3

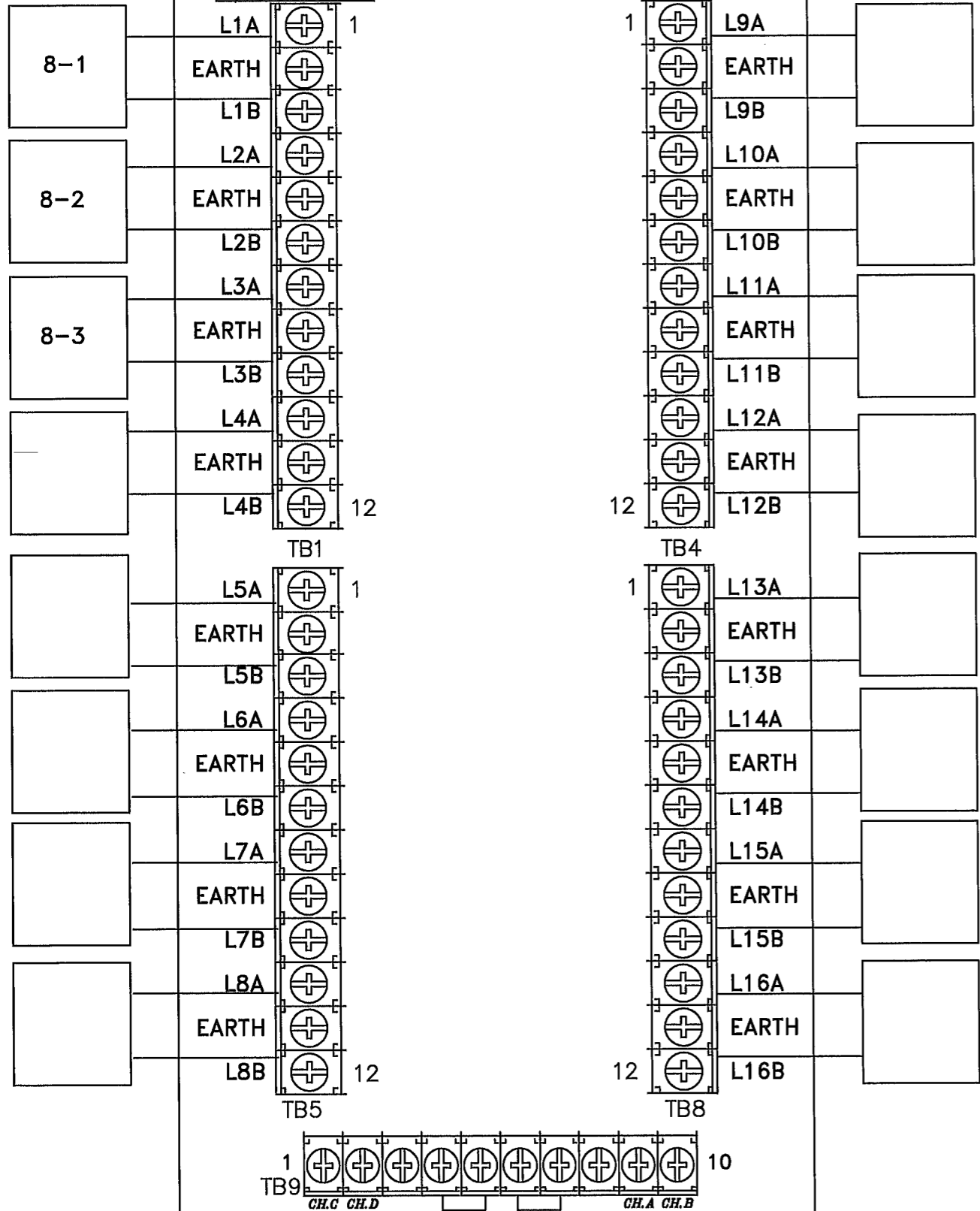

DET. LOOPS 9-16 (J15) C/C 33284G3

PIN	SIGNAL	TO
1	LOOP 9+	LPI2: TB4-1
2	LOOP 9-	LPI2: TB4-3
3	LOOP 10+	LPI2: TB4-4
4	LOOP 10-	LPI2: TB4-6
5	LOOP 11+	LPI2: TB4-7
6	LOOP 11-	LPI2: TB4-9
7	LOOP 12+	LPI2: TB4-10
8	LOOP 12-	LPI2: TB4-12
9	LOOP 13+	LPI2: TB8-1
10	LOOP 13-	LPI2: TB8-3
11	LOOP 14+	LPI2: TB8-4
12	LOOP 14-	LPI2: TB8-6
13	LOOP 15+	LPI2: TB8-7
14	LOOP 15-	LPI2: TB8-9
15	LOOP 16+	LPI2: TB8-10
16	LOOP 16-	LPI2: TB8-12
17	----	
18	----	
19	----	
20	----	

DET. LOOPS 1-8 (J14) C/C 33284G2

PIN	SIGNAL	TO
1	LOOP 1+	LPI1: TB1-1
2	LOOP 1-	LPI1: TB1-3
3	LOOP 2+	LPI1: TB1-4
4	LOOP 2-	LPI1: TB1-6
5	LOOP 3+	LPI1: TB1-7
6	LOOP 3-	LPI1: TB1-9
7	LOOP 4+	LPI1: TB1-10
8	LOOP 4-	LPI1: TB1-12
9	LOOP 5+	LPI1: TB5-1
10	LOOP 5-	LPI1: TB5-3
11	LOOP 6+	LPI1: TB5-4
12	LOOP 6-	LPI1: TB5-6
13	LOOP 7+	LPI1: TB5-7
14	LOOP 7-	LPI1: TB5-9
15	LOOP 8+	LPI1: TB5-10
16	LOOP 8-	LPI1: TB5-12
17	PMT. DET. CH. C	LPI1: TB9-1
18	PMT. DET. CH. D	LPI1: TB9-2
19	KEY PIN	
20	PMT. CH. C/D +26VDC	LPI1: TB9-3
21	PMT. DC GROUND	LPI1: TB9-4,7
22	PMT. CH. A/B +26VDC	LPI1: TB9-8
23	PMT. DET. CH. A	LPI1: TB9-9
24	PMT. DET. CH. B	LPI1: TB9-10
25	----	
26	----	

DET. RACK POWER C/C 34842G5			
P1/ DR: J13	P2/ DR: J17	FUNCTION	TO
1		+12 VDC (DET. POWER)	PB-3
2		+24 VDC (BIU POWER)	PB-2
3		LOGIC GROUND	PB-1
4		EARTH GROUND	PB-9
5		"KEY PIN"	
6		LINE FREQUENCY REF.	PB-5
	1	EARTH GROUND	----
	2	AC LINE	PB-12
	3	AC NEUTRAL	PB-10
	4	LOGIC GROUND	----

EXPANSION OUTPUTS C/C 33284G8		
J16	FUNCTION	TO
17	DET. 17 / PMT. A OUT	MP: B19
18	DET. 18 / PMT. B OUT	MP: B20
19	PMT. C OUT	MP: B17
20	PMT. D OUT	MP: B18

DETECTOR LOOP INTERFACE

B.I.U	DET	PH	F	DET	DLY	EXT	DET	PH	F	DET	DLY	EXT	DET	PH	F	DET	DLY	EXT	DET	PH	F	DET	DLY	EXT	EVP	PH	POLE #	CONT CH #
	CH 1	1		1-1			CH 5	2		2-1			CH 9	3		3-1			CH 13	4		4-1			CH 1	1-6	3	3
	CH 2	1		1-2			CH 6	2		2-2			CH 10	3		3-2			CH 14	4		4-2			CH 2	2-5	1	4
	CH 3	5		5-1			CH 7	6		6-1			CH 11	7		7-1			CH 15						CH 3	3-8	4	5
	CH 4	5		5-2			CH 8	6		6-2			CH 12	7		7-2			CH 16						CH 4	4-7	2	6
B.I.U	DET	PH	F	DET	DLY	EXT	DET	PH	F	DET	DLY	EXT	DET	PH	F	DET	DLY	EXT	DET	PH	F	DET	DLY	EXT				
	CH 17	8		8-1			CH 21						CH 25						CH 29									
	CH 18	8		8-2			CH 22						CH 26						CH 30									
	CH 19	8		8-3			CH 23						CH 27						CH 31									
	CH 20						CH 24						CH 28						CH 32									

EVP SENSORS

CABLE	DISCR. CHAN.	PHASES	POLE#	TERMINAL TB9		
				SIGNAL	DC(+)	GND
33/57	1	1-6	3/7	9	8	7
23/45	2	2-5	1/6	10	8	7
11/54	3	3-8	4/5	1	3	4
20	4	4-7	2	2	3	4

VEHICLE SIGNALS

CABLE	SIGNAL	TERMINAL						
		G←	FYA	Y←	R←	G	Y	R
30	1-1	1		3	5			
14	1-2	2		4	6			
40	2-1,2-3					7	9	11
41	2-2					8	10	12
50	3-1	13	57	15	17			
30	3-2	14	58	16	18			
15	4-1					19	21	23
14	4-2					20	22	24
42	5-1	25		27	29			
49	5-2	26		28	30			
28	6-1,6-3					31	33	35
29	6-2					32	34	36
16	7-1	37	69	39	41			
42	7-2	38	70	40	42			
50	8-1					43	45	47
49	8-2					44	46	48

VEH DETECTORS

CABLE	DET	SLOT	FUNC	RACK	TERMINAL
47	1-1	1	1	1	L1
48	1-2	2	1	1	L2
24	2-1	5	1	1	L5
25	2-2	6	1	1	L6
12	3-1	9	1	1	L9
13	3-2	10	1	1	L10
39	4-1	13	3/8	1	L13
36	4-2	14	7	1	L14
26	5-1	3	1	1	L3
27	5-2	4	1	1	L4
58	6-1	7	1	1	L7
59	6-2	8	1	1	L8
37	7-1	11	1	1	L11
38	7-2	12	1	1	L12
10	8-1	17	3/8	2	L1
8	8-2	18	7	2	L2
9	8-3	19	1	2	L3

PED PUSHBUTTONS

CABLE	PPB	TERMINAL	RETURN
31	4-1	PD4	GB1
18	4-2	PD4	GB1

PED SIGNALS

CABLE	SIGNAL	TERMINAL	
		WK	DW
29	4-1	55	59
15	4-2	56	60

EVP VERIFY LIGHTS

CABLE	CONTR CHAN.	PHASES	POLE#	TERM.
32	3	1-6	3	13R
44	4	2-5	1	14R
53	5	3-8	4	15R
19	6	4-7	2	16R