

MAIN PANEL:171-1081-504

COBALT TS2	LEGEND
<ul style="list-style-type: none"> <li>■ CONFIGURATION:L3604</li> <li>■ SOFTWARE:EOS</li> <li>■ ETHERNET MODULE</li> </ul>	<ul style="list-style-type: none"> <li>BIU BUS INTERFACE UNIT</li> <li>BU() C/C, BIU ()</li> <li>CB() CIRCUIT BREAKER ()</li> <li>C/C CONNECTING CABLE</li> <li>CCA CONTROLLER CABLE "A"</li> <li>CDP C/C, DR POWER</li> <li>CMA MMU/CMU CABLE "A"</li> <li>CMB MMU/CMU CABLE "B"</li> <li>CPO C/C PRE-EMPT OUTPUTS</li> <li>CPP C/C PRE-EMPT POWER</li> <li>DR DETECTOR RACK</li> <li>DS() DOOR SWITCH ()</li> <li>FL() FLASHER ()</li> <li>FR() FLASH XFER. RELAY</li> <li>LS() LOAD SWITCH</li> <li>MC MERCURY CONTACTOR</li> <li>MP MAIN PANEL</li> <li>PAP POWER-AUX PANEL</li> <li>PSP CAB. PWR. SUPPLY</li> <li>SA SURGE ARRESTOR</li> <li>TB-() TERM. BLOCK ()</li> </ul>
<ul style="list-style-type: none"> <li>□ OVERLAPS</li> <li>□ IN EEPROM</li> <li>□ KEYBOARD ENTERED</li> </ul>	
<ul style="list-style-type: none"> <li>□ ANALOG TELEMETRY MOD.: 100-1005-501</li> <li>■ INTERNAL RS-232 TELEMETRY</li> <li>□ TEST INPUT A =</li> <li>□ TEST INPUT B =</li> </ul>	<div style="display: flex; align-items: center;"> <div style="margin-right: 10px;"> <p>A =</p> <p>B =</p> <p>C =</p> <p>D =</p> </div> </div>

FLASHER	
PIN	FUNCTION
7	CIRCUIT #1
8	CIRCUIT #2
9	CHASSIS GND
10	AC COMMON
11	115 VAC
12	-----

LOAD SWITCH	
PIN	FUNCTION
1	115 VAC
2	CHASSIS GND
3	RED/DW OUTPUT
4	-----
5	YEL OUTPUT
6	RED/DW INPUT
7	GRN/W OUTPUT
8	YEL INPUT
9	+24 VDC
10	GRN/W INPUT
11	AC COMMON
12	-----

① 2.2K  
10W

MAIN PANEL PLUG-IN REQUIREMENTS

BIU2 T&F	BIU3 T&F	LS9 PED 2 FYA 1	LS10 PED 4 FYA 3	LS11 PED 6 FYA 5	LS12 PED 8 FYA 7	LS13 BEACONS	LS14 BEACONS	LS15 BEACONS	LS16 BEACONS
BIU1 T&F	LS1 VEH 1	LS2 VEH 2	LS3 VEH 3	LS4 VEH 4	LS5 VEH 5	LS6 VEH 6	LS7 VEH 7	LS8 VEH 8	FL1
FR1 L R V1 V5	FR2 L R V2 V6	FR3 L R V3 V7	FR4 L R V4 V8	FR5 L R A C	FR6 L R B D	K1 LS 24V CONT.			

■ DENOTES TYPE OF OPERATION AND/OR WHERE PLUG-IN IS REQUIRED. L = LEFT, R = RIGHT.  
 ☒ DENOTES WHERE "UNUSED RED" JUMPER PART NUMBER 32448G1 IS REQUIRED. INSTALL BETWEEN PINS 1 & 3 FOR LOAD SWITCH OR PINS 6 & 8 AND 5 & 7 FOR FLASH TRANSFER RELAY.

FLASH:  
 □ ø2&6 YELLOW, ALL OTHERS RED.  
 ■ ALL RED.  
 ■ RELAYS DE-ENERGIZED FOR FLASH.  
 □ RELAYS ENERGIZED FOR FLASH.

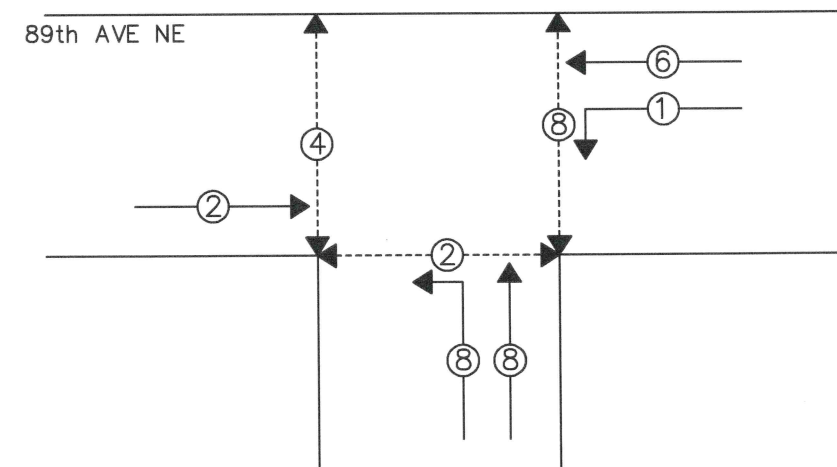

SHEET 1 OF 9

3 USE ONLY COPPER CONDUCTORS FOR FIELD AND SERVICE CONNECTIONS.

2 CONNECT A.C. SERVICE TO TERMINAL BLOCK 501 (LINE), 502 (NEUTRAL) AND GB2 (EARTH) ON RIGHT SIDEWALL OF CABINET.

① INSTALL 2.2K, 10 WATT LOAD RESISTORS BETWEEN PINS 7 AND 11 ON LOAD SWITCHES 9, 10, 11 & 12.

NOTES: UNLESS SPECIFIED OTHERWISE

DESIGNER G.V. T.C.C.	DATE 02/22/2018	<b>ECONOLITE</b> CONTROL PRODUCTS INC.	<b>TRAFFIC CONTROL CORPORATION</b>	780 W. BELDEN SUITE D ADDISON, IL 60101
DRAWN CM TCC	02/22/2018			CABINET SPECIFICATION: TS2TYPE1 ANOKA COUNTY SPEC PLUG AND GO
CABINET SIZE	77"	CUSTOMER:		
INSPECTED		INTERSECTION: 89TH AT 87TH LANE		
APPROVED		LOCATION:		
CUSTOMER P.O.	INSTALLED BY	SALES ORDER NO.	SIZE B	DRAWING #TS2AC16PG--

CONTROLLER  
 FLASHER  
 SW.PACKS

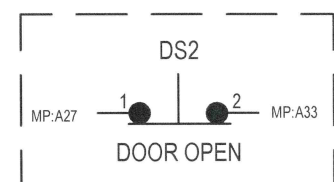
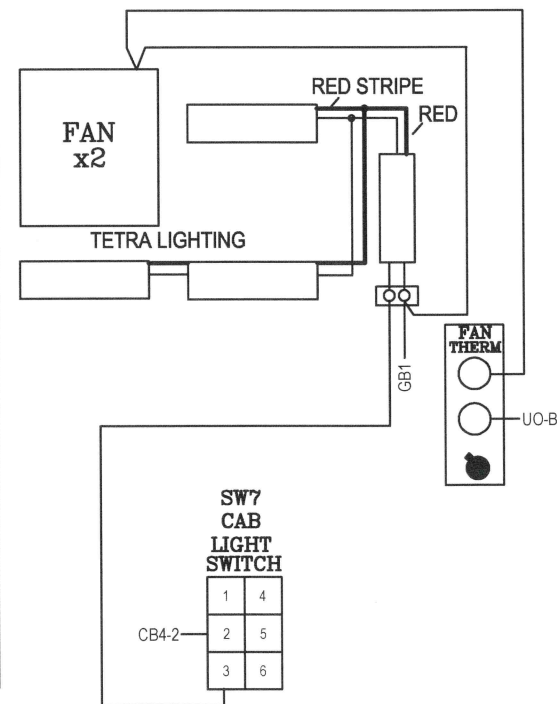
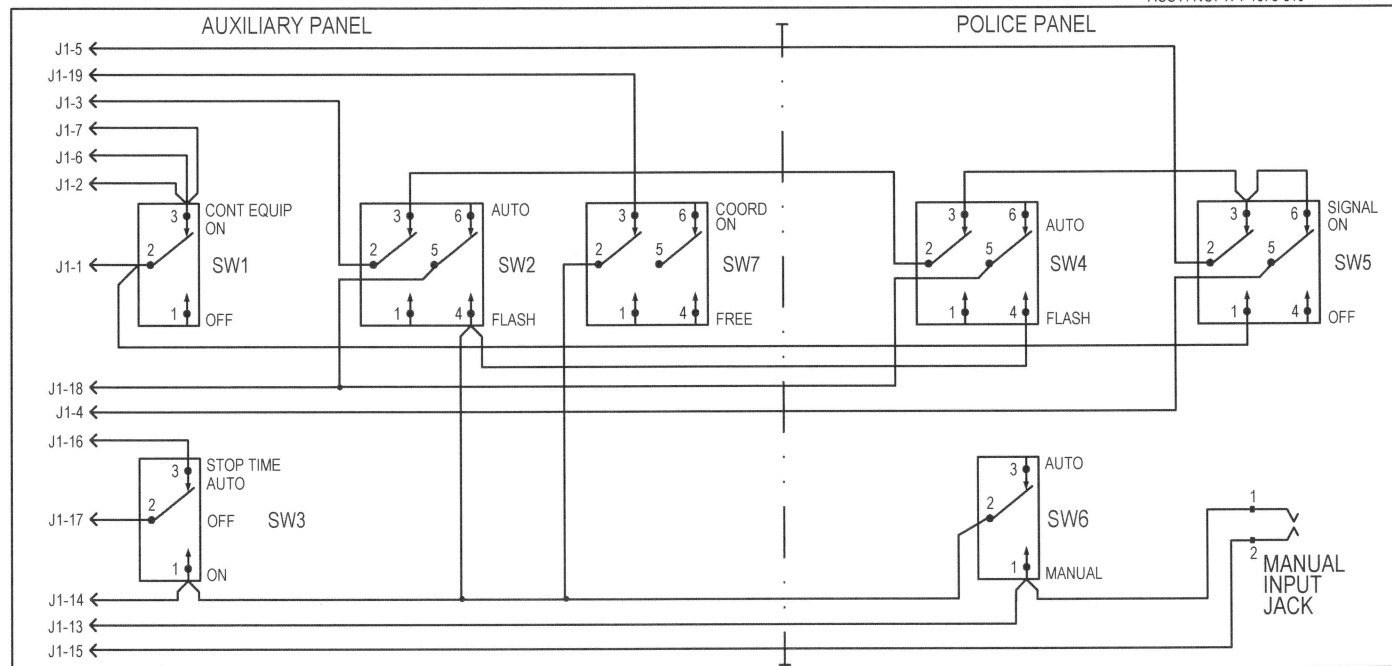

- 901 — TB2-12 (120VAC+)
  - 902 — TB2-10 (120VAC-)
  - 903 — TB2-9 (CHASS. GND)
  - 904
- MOUNTED ON LEFT SIDE

AC POWER		C/C 171-1083-528/529	
POWER BUS -PB-	FUNCTION	POWER PANEL -CP-	
TB2-12B	FILTERED AC+LINE OUT	CB3-2	
TB2-10B	AC NEUTRAL OUT	SA-NO	
TB2-9B	EARTH GND.	GND	
TB2-8B	SIG BUS CNTRL	SSR-3	

- J3
- J3-36 — 1
- MMB-1 — 2
- MMA-37 — 3
- K1-10 — 4
- FR6-2 — 5
- MMB-2 — 6
- MMA-20 — 7
- 8
- 9
- 10
- 11
- 12
- A-39 — 13
- A-35 — 14
- A-40 — 15
- A-31 — 16
- A-30 — 17
- A-32 — 18
- A-38 — 19
- A-33 — 20
- A-34 — 21
- K1-9 — 22
- B-3 — 23
- B-4 — 24
- A-35 — 25
- K1-11 — 26
- 27
- 30
- 31
- 32
- 33
- 34
- 35
- 36
- 37
- B-5 — 28
- J1-31B — 29
- J1-27B — 31
- K1-10 — 32
- 33
- K1-2 — 34
- MMB-18 — 35
- J3-1 — 36
- (N/U) — 37

(MAIN PANEL & C/C REFERENCES ONLY)

TO/FROM POLICE-AUXILIARY SWITCH PANEL	
PIN	FUNCTION
1	FILTER AC LINE (OUT)
2	SWITCHED AC LINE (IN)
3	FLASH CONTROL BUS (OUT)
4	SIGNAL BUS CONTROL (IN)
5	FLASH RELAY CONTROL (IN)
6	START DELAY AC BUS (IN)
7	MMU FLASH CONTROL BUS (IN)
8	SPARE
9	SPARE
10	SPARE
11	SPARE
12	SPARE
13	MANUAL CONT. ENABLE (IN)
14	LOGIC GROUND
15	OPT-INTERVAL ADVANCE (IN)
16	MMU STOP TIME (OUT)
17	CONTROLLER STOP TIME (IN)
18	LOCAL FLASH STATUS (IN)
19	OPT-COORD FREE (IN)
20	OPT-ALARM 1 (IN)
21	ALARM 2 (IN)
22	LOADSWITCH TEST (IN)
23	MMU 24 VOLT MON. 2 (IN)
24	+24 VDC
25	LOGIC GROUND
26	+24 VDC (IN)
27	---
28	MMU FAULT MONITOR (IN)
29	LINE FREQ. REFERENCE (IN)
30	---
31	12 VAC (IN)
32	SIGNAL BUS CONTROL (IN)
33	---
34	FILTERED AC NEUTRAL (IN)
35	CONT. EQUIP. AC LINE (OUT)
36	FILTERED AC LINE (IN)
37	---

MP P3	MAIN PANEL/CONTROLLER PWR. C/C 171-1676-504	TO POL/AUX P1
PIN	FUNCTION	PIN
1	FILTER AC LINE (OUT)	1
2	SWITCHED AC LINE (IN)	2
3	FLASH CONTROL BUS (OUT)	3
4	SIGNAL BUS CONTROL (IN)	4
5	FLASH RELAY CONTROL (IN)	5
6	START DELAY AC BUS (IN)	6
7	MMU FLASH CONTROL BUS (IN)	7
8	SPARE	8
9	SPARE	9
10	SPARE	10
11	SPARE	11
12	SPARE	12
13	OPT-MANUAL CONT. ENABLE (IN)	13
14	LOGIC GROUND	14
15	OPT-INTERVAL ADVANCE (IN)	15
16	MMU STOP TIME (OUT)	16
17	CONTROLLER STOP TIME (IN)	17
18	LOCAL FLASH STATUS (IN)	18
19	OPT-COORD FREE (IN)	19
20	OPT-ALARM 1 (IN)	20
21	ALARM 2 (IN)	21
22	OPT-LOADSWITCH TEST (IN)	22
23	MMU 24 VOLT MON. 2 (IN)	23
24	+24 VDC	24
PART OF 171-1076-504		TO PB.(JX)
25	LOGIC GROUND	1
26	+24 VDC (IN)	2
27	(N/U)	3
28	MMU FAULT MONITOR (IN)	4
29	LINE FREQ. REFERENCE (IN)	5
30	(N/U)	6
31	12 VAC (IN)	7
32	SIGNAL BUS CONTROL (IN)	8
33	(N/U)	9
34	FILTERED AC NEUTRAL (IN)	10
35	CONT. EQUIP. AC LINE (OUT)	11
36	FILTERED AC LINE (IN)	12
37	(N/U)	13
(N/U)	(N/U)	14

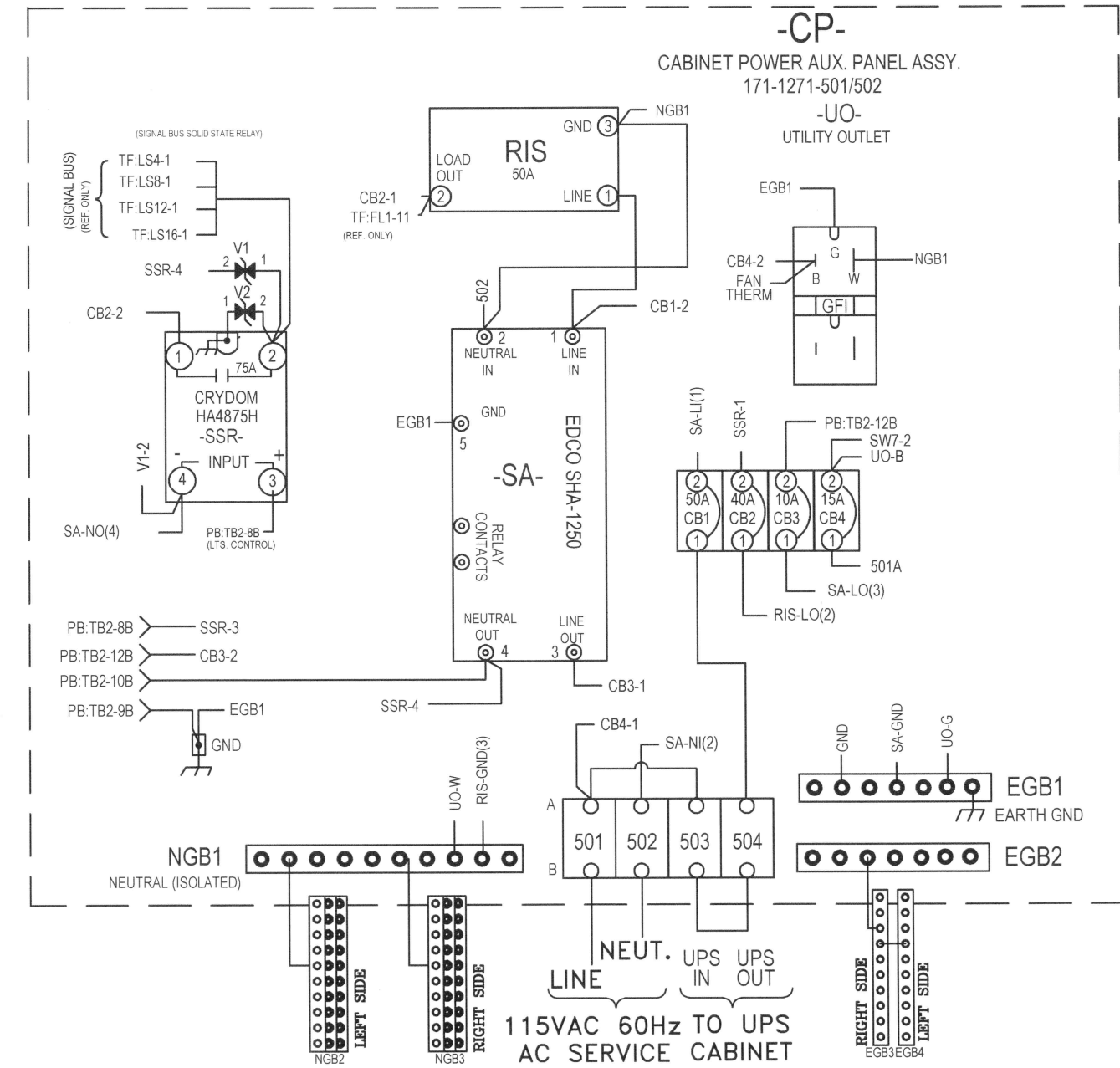

POLICE/AUXILIARY SWITCH PANEL		
J1 PIN	FUNCTION	TO
1	FILTER AC LINE (IN)	SW1-2
2	SWITCHED AC LINE (OUT)	SW1-3
3	FLASH CONTROL BUS (IN)	SW2-2
4	SIGNAL BUS CONTROL (OUT)	SW5-5
5	FLASH RELAY CONTROL (OUT)	SW5-2
6	START DELAY BUS (OUT)	SW1-3
7	MMU FLASH CONTROL BUS (OUT)	SW1-3
8	SPARE	---
9	SPARE	---
10	SPARE	---
11	SPARE	---
12	SPARE	---
13	MANUAL CONT. ENABLE (OUT)	SW6-1
14	LOGIC GROUND	SW3-1
15	INTERVAL ADVANCE (OUT)	MIJ-2
16	MMU STOP TIME (IN)	SW3-3
17	CONTROLLER STOP TIME (OUT)	SW3-2
18	LOCAL FLASH STATUS (OUT)	SW2-5
19	COORD FREE (OUT)	---
20	ALARM 1 (OUT)	---
21	ALARM 2 (OUT)	---
22	LOADSWITCH TEST (OUT)	---
23	MMU 24 VOLT MON. 2 (OUT)	---
24	+24 VDC (IN)	---

# CONFIRMATION BEACONS

EVP 3 = 1-6  
 EVP 4 = 2  
 EVP 5 = 8  
 EVP 6 =

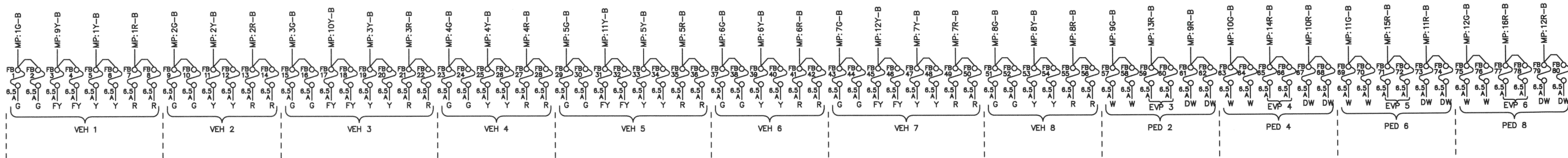
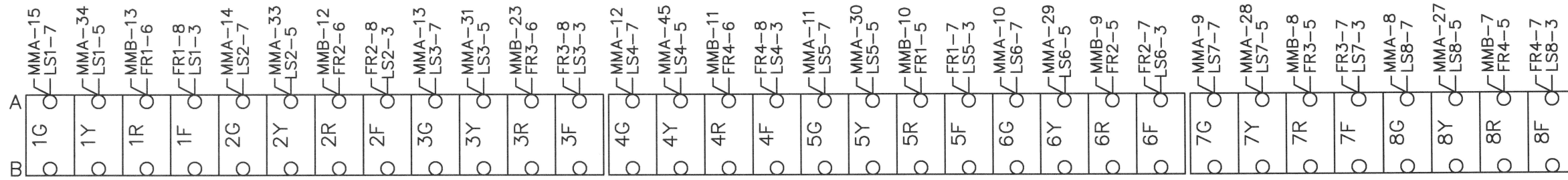
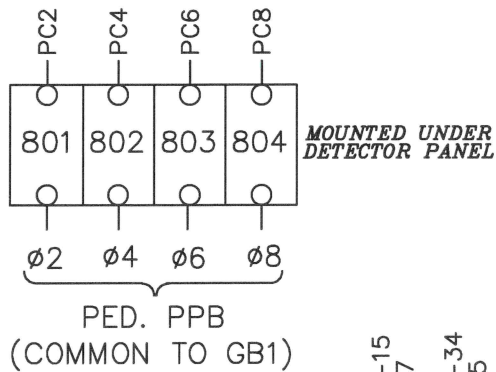
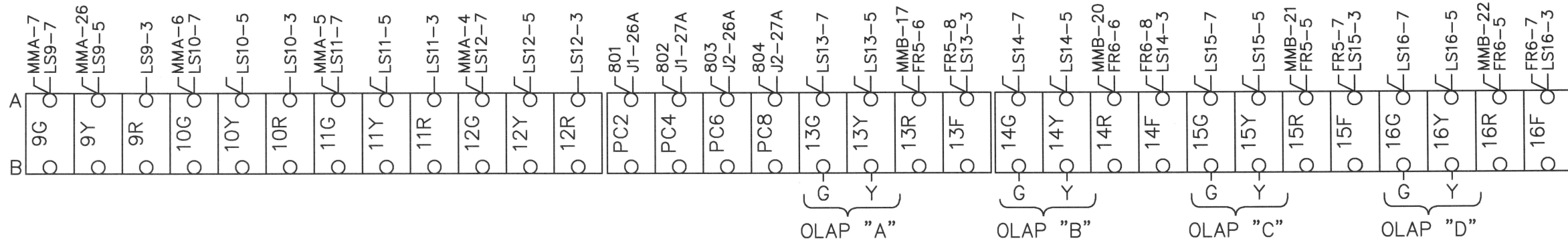

## SIGNAL FIELD TERMINALS

①  
2.2K  
10W

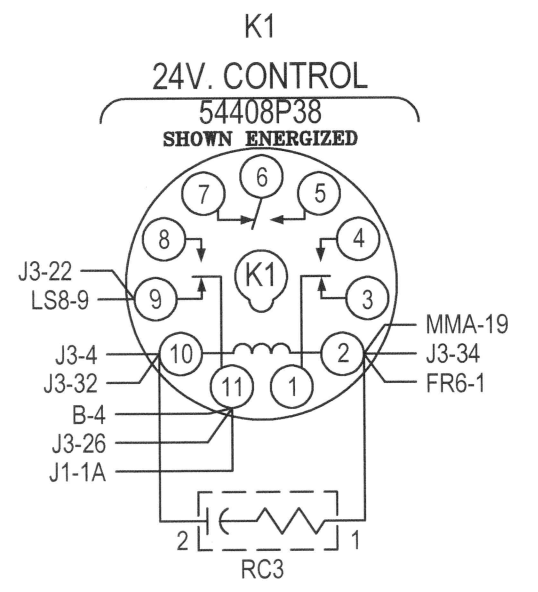
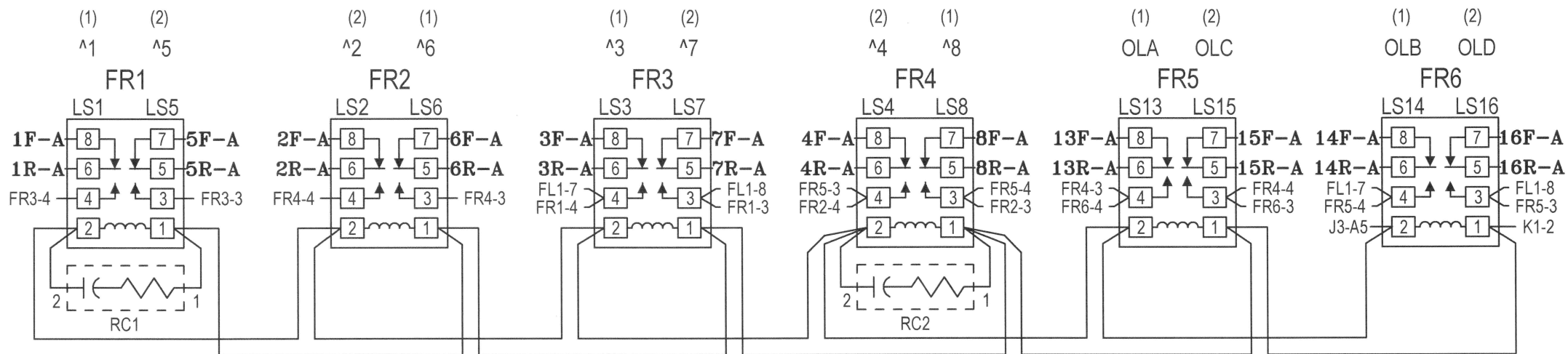
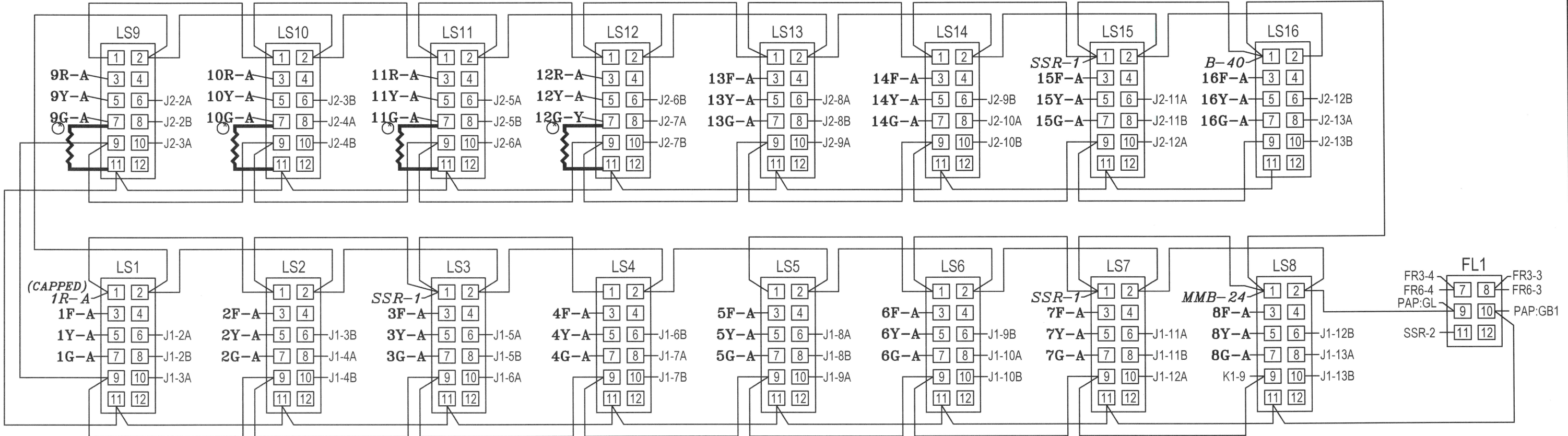

**LOADBAY AND FLASH RELAY'S**

1	M.M.U. RESET	MMA-49J2-21B	RG. 1 INHBT. MAX.
2	24 V. MON. INHBT.	MMA-36J2-22A	RG. 2 INHBT. MAX.
3	M.M.U. +24 V. MON. 2	J3-23 MMA-15	RG. 1 FORCE OFF
4	M.M.U. +24 V. MON. 1	K1-11 J3-24 MMA-16	RG. 2 FORCE OFF
5	FAULT MON.	J3-28 MMA-35	RG. 1 MAX. 2 SEL.
6	PC1 PED. DET. 1	J1-25B J1-23A	RG. 2 MAX. 2 SEL.
7	PC3 PED. DET. 3	J1-26B J1-24B	CALL NONACT 1
8	PC5 PED. DET. 5	J2-25BJ2-19A	CALL NONACT 2
9	PC7 PED. DET. 7	J2-26BJ1-25A	WALK REST MDJFR.
10	DET. 61	J2-19B J1-20A	EXT. MIN. RECALL
11	DET. 62	J2-20A J1-20B	EXT. START
12	DET. 63	J2-20B J1-17A	TEST INPUT A
13	DET. 64	J2-21A J1-17B	TEST INPUT B
14	LOGIC GND.	MMA-17 J1-32AJ2-25A A-20	TEST INPUT C
15	PMT. CALL 1	J1-16A J1-21A	T.B.C. ON LINE
16	PMT. CALL 2	J1-16B J1-14A	T.B.C. AUX. 1
17	PMT. CALL 3	J2-17A J1-14B	T.B.C. AUX. 2
18	PMT. CALL 4	J2-17B J2-14A	T.B.C. AUX. 3
19	PMT. CALL 5	J2-18A J2-14B	COORD. STATUS OUT
20	PMT. CALL 6	J2-18B MMA-55 A-27	LOGIC GND.

J16-19  
J16-20  
J16-17  
J16-18

21	MMA AC+ I IN	MMA-1	J1-15A	PMT. 1 ACTV.
22	DIR1 OPEN	MMA-2	J1-15B	PMT. 2 ACTV.
23	DIR2 CLSD	MMA-3	J2-15A	ALARM 3
24	MMA SPR 1	MMA-48	J2-15B	ALARM 4
25	CAB INTLK A	MMA-50	J2-16A	ALARM 5
26	CAB INTLK B	MMA-51	J2-16B	ALARM 6
27	MMA SPR 2	MMA-54	A-35 MMA-21 A-20	LOGIC GND
28	SDR OPEN	MMB-3		LOGIC GND
29	MMB SPR 1	MMB-14		LOGIC GND
30	MMB SPR 2	MMB-16	J1-21B J1-22A J3-17	STOP TIMING 1 & 2
31	MMB SPR 3	MMB-25J2-23A	MMA-38 J3-16	MMU STOP TIMING
32		MMB-26 J2-22B	J3-16	LOCAL FLASH STATUS
33		J2-23B	J3-18	ALARM 1
34		J3-20	J2-20	ALARM 2
35		J2-24A	J3-21	LOGIC GND
36		A-27 J3-25 J3-14	J1-18B	DIM. ENABLE
37	SB AC+	MMB-4	J1-18A	AUTO FLASH
38	SB AC+	MMB-5	J2-24B J3-19	COORD. FREE
39	SB AC+	MMB-6	J1-19A J3-13	MANUAL CONT. ENABLE
40	SB AC+	MMB-19 LS16-1	J1-19B J3-15	INTRVL ADV.

INTERFACE TERMINAL BLOCKS

BIU #1		
PIN	FUNCTION	TO
1A	+24 VDC	K1-11
1B	+24 VDC	J2-1B
2A	LS1 RED	LS1-6
2B	LS1 YELLOW	LS1-8
3A	LS1 GREEN	LS1-10
3B	LS2 RED	LS2-6
4A	LS2 YELLOW	LS2-8
4B	LS2 GREEN	LS2-10
5A	LS3 RED	LS3-6
5B	LS3 YELLOW	LS3-8
6A	LS3 GREEN	LS3-10
6B	LS4 RED	LS4-6
7A	LS4 YELLOW	LS4-8
7B	LS4 GREEN	LS4-10
8A	LS5 RED	LS5-6
8B	LS5 YELLOW	LS5-8
9A	LS5 GREEN	LS5-10
9B	LS6 RED	LS6-6
10A	LS6 YELLOW	LS6-8
10B	LS6 GREEN	LS6-10
11A	LS7 RED	LS7-6
11B	LS7 YELLOW	LS7-8
12A	LS7 GREEN	LS7-10
12B	LS8 RED	LS8-6
13A	LS8 YELLOW	LS8-8
13B	LS8 GREEN	LS8-10
14A	TBC AUX 1	A-16
14B	TBC AUX 2	A-17
15A	PMT ACT 1	A-21
15B	PMT ACT 2	A-22
16A	PMT CALL 1	B-15
16B	PMT CALL 2	B-16
17A	TEST A	A-12
17B	TEST B	A-13
18A	AUTO FLASH	A-37
18B	DIM. ENABLE	A-36
19A	MANUAL CONT.	A-39
19B	INT. ADVANCE	A-40
20A	EXT. MIN. RECALL	A-10
20B	EXT. START	A-11
21A	TBC ONLINE	A-15
21B	STOP TIME (1)	A-30
22A	STOP TIME (2)	A-30
22B	MAX. 2 (1)	A-5
23A	MAX. 2 (2)	A-6
23B	FORCE OFF (1)	A-3
24A	FORCE OFF (2)	A-4
24B	CNA 1	A-7
25A	WALK REST MOD.	A-9
25B	PED. ISO. 1	B-6
26A	PED. ISO. 2	PC2-A
26B	PED. ISO. 3	B-7
27A	PED. ISO. 4	PC4-A
27B	PED. ISO. COMN.	J3-D1
28A	ADDR. SEL. 0	---
28B	ADDR. SEL. 1	---
29A	ADDR. SEL. 2	---
29B	ADDR. SEL. 3	---
30A	RESERVED	---
30B	RESERVED	---
31A	EARTH GND.	LS12-2
31B	LINE FREQ. REF.	J3-C9
32A	LOGIC GND.	B-14
32B	LOGIC GND.	J2-32A

BIU #2		
PIN	FUNCTION	TO
1A	+24 VDC	J2-1B
1B	+24 VDC	J1-1B
2A	LS9 RED	LS9-6
2B	LS9 YELLOW	LS9-8
3A	LS9 GREEN	LS9-10
3B	LS10 RED	LS10-6
4A	LS10 YELLOW	LS10-8
4B	LS10 GREEN	LS10-10
5A	LS11 RED	LS11-6
5B	LS11 YELLOW	LS11-8
6A	LS11 GREEN	LS11-10
6B	LS12 RED	LS12-6
7A	LS12 YELLOW	LS12-8
7B	LS12 GREEN	LS12-10
8A	LS13 RED	LS13-6
8B	LS13 YELLOW	LS13-8
9A	LS13 GREEN	LS13-10
9B	LS14 RED	LS14-6
10A	LS14 YELLOW	LS14-8
10B	LS14 GREEN	LS14-10
11A	LS15 RED	LS15-6
11B	LS15 YELLOW	LS15-8
12A	LS15 GREEN	LS15-10
12B	LS16-RED	LS16-6
13A	LS16-YELLOW	LS16-8
13B	LS16-GREEN	LS16-10
14A	TBC AUX 3	A-18
14B	COORD. STATUS	A-19
15A	ALARM 3	A-23
15B	ALARM 4	A-24
16A	ALARM 5	A-25
16B	ALARM 6	A-26
17A	PMT CALL 3	B-17
17B	PMT CALL 4	B-18
18A	PMT CALL 5	B-19
18B	PMT CALL 6	B-20
19A	CNA 2	A-8
19B	SPARE 1	B-10
20A	SPARE 2	B-11
20B	SPARE 3	B-12
21A	SPARE 4	B-13
21B	INHIBIT MAX (1)	A-1
22A	INHIBIT MAX (2)	A-2
22B	LOCAL FLASH	A-32
23A	MMU FLASH	A-31
23B	ALARM 1	A-33
24A	ALARM 2	A-34
24B	COORD FREE IN	A-38
25A	TEST C	A-14
25B	PED. ISO. 5	B-8
26A	PED. ISO. 6	PC6-A
26B	PED. ISO. 7	B-9
27A	PED. ISO. 8	PC8-A
27B	PED. ISO. COMN.	J1-27B
28A	ADDR. SEL. 0	J2-32A
28B	ADDR. SEL. 1	---
29A	ADDR. SEL. 2	---
29B	ADDR. SEL. 3	---
30A	RESERVED	---
30B	RESERVED	---
31A	EARTH GND.	J1-31A
31B	LINE FREQ. REF.	J1-31B
32A	LOGIC GND.	J1-32B
32B	LOGIC GND.	J2-32A

DETECTOR BIU		
PIN	FUNCTION	TO
1A	+24 VDC	---
1B	+24 VDC	---
2A	---	---
2B	---	---
3A	---	---
3B	---	---
4A	---	---
4B	---	---
5A	---	---
5B	---	---
6A	---	---
6B	---	---
7A	---	---
7B	---	---
8A	---	---
8B	---	---
9A	---	---
9B	---	---
10A	CH. 1 CALL	---
10B	CH. 2 CALL	---
11A	CH. 3 CALL	---
11B	CH. 4 CALL	---
12A	CH. 5 CALL	---
12B	CH. 6 CALL	---
13A	CH. 7 CALL	---
13B	CH. 8 CALL	---
14A	CH. 9 CALL	---
14B	CH. 10 CALL	---
15A	CH. 11 CALL	---
15B	CH. 12 CALL	---
16A	CH. 13 CALL	---
16B	CH. 14 CALL	---
17A	CH. 15 CALL	---
17B	CH. 16 CALL	---
18A	CH. 1 FAULT STATUS	---
18B	CH. 2 FAULT STATUS	---
19A	CH. 3 FAULT STATUS	---
19B	CH. 4 FAULT STATUS	---
20A	CH. 5 FAULT STATUS	---
20B	CH. 6 FAULT STATUS	---
21A	CH. 7 FAULT STATUS	---
21B	CH. 8 FAULT STATUS	---
22A	CH. 9 FAULT STATUS	---
22B	CH. 10 FAULT STATUS	---
23A	CH. 11 FAULT STATUS	---
23B	CH. 12 FAULT STATUS	---
24A	CH. 13 FAULT STATUS	---
24B	CH. 14 FAULT STATUS	---
25A	CH. 15 FAULT STATUS	---
25B	CH. 16 FAULT STATUS	---
26A	---	---
26B	---	---
27A	---	---
27B	---	---
28A	ADDR. SEL. 0	---
28B	ADDR. SEL. 1	---
29A	ADDR. SEL. 2	---
29B	ADDR. SEL. 3	---
30A	---	---
30B	---	---
31A	EARTH GND.	J1-31A
31B	LINE FREQ. REF.	J1-31B
32A	LOGIC GND.	J1-32B
32B	LOGIC GND.	J2-32A

MAIN PANEL CONTROL POWER C/C 171-1676-504	
PIN	FUNCTION
1	LOGIC GND
2	+24 VDC (IN)
3	---
4	MMU FAULT MONITOR (IN)
5	LINE FREQ. REFERENCE (IN)
6	---
7	+12 VAC (IN)
8	SIGNAL BUS CONTROL (IN)
9	---
10	FILTERED AC NEUTRAL (IN)
11	CONT. EQUIP. AC LINE (OUT)
12	FILTERED AC LINE (IN)
13	---
14	---

CONTROLLER POWER (CCA2) C/C 171-1676-503			
WIRE	PIN	SIGNAL	TO
1	A	FAULT MONITOR	PB-4
2	U	AC NEUTRAL	PB-10
3	V	EARTH GROUND	PB-9
4	W	LOGIC GROUND	PB-1
5	P	AC LINE	PB-11
6	SHL	EARTH GROUND	CCA2-V

TYPE 1 CONTROLLER POWER C/C 171-1676-502		
PIN	FUNCTION	TO
A	AC NEUTRAL	PB-10
B	---	---
C	AC LINE	PB-11
D	---	---
E	+12 VDC	PB-3
F	+24 VDC	PB-2
G	RESERVED	---
H	LOGIC GND.	PB-1
I	LOGIC GND.	PB-1
J	EARTH GND.	PB-9
K	+12 VAC	PB-7
L	---	---
M	RESERVED	---
N	EARTH GND.	PIN H

CABINET POWER SUPPLY C/C 171-1676-511		
PIN	FUNCTION	TO
A	AC NEUTRAL	PB-10
B	LINE FREQUENCY REF.	PB-5
C	AC LINE	PB-11
D	+12 VDC	PB-3
E	+24 VDC	PB-2
F	RESERVED	---
G	LOGIC GND.	PB-1
H	EARTH GND.	PB-9
I	+12 VAC	PB-7
J	RESERVED	---
K	EARTH GND.	PIN H

CONTROLLER PORT 1 CONNECTOR			
PIN	SIGNAL	TO	FUNCTION
1	TWISTED PAIR 1+	SDLC-1	CONT TXD+
2	LOGIC GND.	---	---
3	TWISTED PAIR 2+	SDLC-4	CONT TXC+
4	LOGIC GND.	---	---
5	TWISTED PAIR 3+	SDLC-7	CONT RXD+
6	LOGIC GND.	---	---
7	TWISTED PAIR 4+	SDLC-10	CONT RXC+
8	LOGIC GND.	---	---
9	TWISTED PAIR 1-	SDLC-2	CONT TXD-
10	PORT 1 DISABLE	---	---
11	TWISTED PAIR 2-	SDLC-5	CONT TXC-
12	EARTH GND.	SHIELD WIRE	---
13	TWISTED PAIR 3-	SDLC-8	CONT RXD-
14	RESERVED	---	---
15	TWISTED PAIR 4-	SDLC-11	CONT RXC-

MMU & BIU PORT 1 CONNECTOR			
PIN	SIGNAL	TO	FUNCTION
1	TWISTED PAIR 1+	SDLC-1	BIU RXD+
2	LOGIC GND.	---	---
3	TWISTED PAIR 2+	SDLC-4	BIU RXC+
4	LOGIC GND.	---	---
5	TWISTED PAIR 3+	SDLC-7	BIU TXD+
6	LOGIC GND.	---	---
7	TWISTED PAIR 4+	SDLC-10	BIU TXC+
8	LOGIC GND.	---	---
9	TWISTED PAIR 1-	SDLC-2	BIU RXD-
10	PORT 1 DISABLE	---	---
11	TWISTED PAIR 2-	SDLC-5	BIU RXC-
12	EARTH GND.	SHIELD WIRE	---
13	TWISTED PAIR 3-	SDLC-8	BIU TXD-
14	RESERVED	---	---
15	TWISTED PAIR 4-	SDLC-11	BIU TXC-

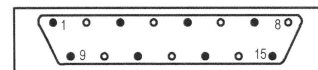

FRONT VIEW OF BU1 - BU5

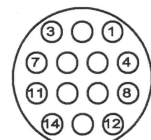

FRONT VIEW OF J1-J6

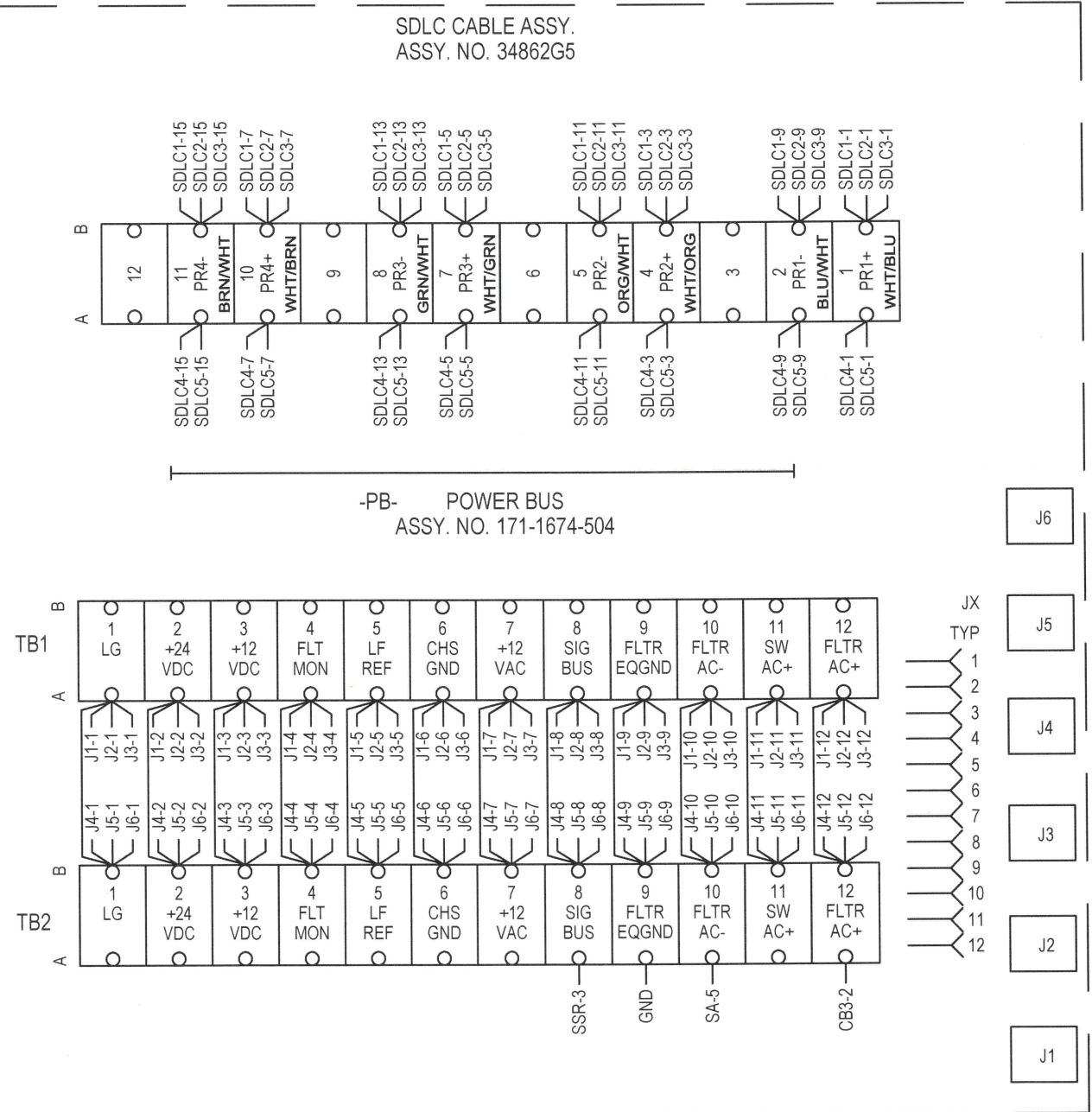

BIU AND CONNECTING CABLES

### WIRE LIST FOR NEMA MALFUNCTION MANAGEMENT UNIT

CONNECTOR "A" (MMA)					CONNECTOR "B" (MMB)				
PIN	WIRE	MON. FUNCTION	TO	SIG. FUNCTION	PIN	WIRE	MON. FUNCTION	TO	SIG. FUNCTION
A	A-1	AC+ I INPUT	B21		A	B-1	AC+ II INPUT	J3-A2	MMU POWER
B	A-2	OUT RLY 1 OPEN	B22		B	B-2	S. DLY RLY COMM.	J3-A6	MMU POWER
C	A-3	OUT RLY 2 CLSD	B23		C	B-3	S. DLY RLY OPEN	B28	
D	A-4	CH. 12 GREEN	12G-A	^8 WLK	D	B-4	CH. 12 RED	B40	
E	A-5	CH. 11 GREEN	11G-A	^6 WLK	E	B-5	CH. 11 RED	B39	
F	A-6	CH. 10 GREEN	10G-A	^4 WLK	F	B-6	CH. 9 RED	B37	
G	A-7	CH. 9 GREEN	9G-A	^2 WLK	G	B-7	CH. 8 RED	8R-A	^8 RED
H	A-8	CH. 8 GREEN	8G-A	^8 GRN	H	B-8	CH. 7 RED	7R-A	^7 RED
J	A-9	CH. 7 GREEN	7G-A	^7 GRN	J	B-9	CH. 6 RED	6R-A	^6 RED
K	A-10	CH. 6 GREEN	6G-A	^6 GRN	K	B-10	CH. 5 RED	5R-A	^5 RED
L	A-11	CH. 5 GREEN	5G-A	^5 GRN	L	B-11	CH. 4 RED	4R-A	^4 RED
M	A-12	CH. 4 GREEN	4G-A	^4 GRN	M	B-12	CH. 2 RED	2R-A	^2 RED
N	A-13	CH. 3 GREEN	3G-A	^3 GRN	N	B-13	CH. 1 RED	1R-A	^1 RED
P	A-14	CH. 2 GREEN	2G-A	^2 GRN	P	B-14	(SPARE 1)	B29	
R	A-15	CH. 1 GREEN	1G-A	^1 GRN	R	B-15	+24V MONITOR II	B-3	+24V MON. II
S	A-16	+24V MON. I	B-4	LS +24V MON.	S	B-16	(SPARE 2)	B30	
T	A-17	LOGIC GND	B-14	LOGIC GND	T	B-17	CH. 13 RED	13R-A	OLA RED
U	A-18	CHASSIS GND	LS7-2	EARTH GND.	U	B-18	S. DLY RLY CLSD	J3-D5	CONT. POWER
V	A-19	AC- (COMMON)	K1-2	AC NEUTRAL	V	B-19	CH. 10 RED	B38	
W	A-20	OUT RLY 1 COM.	J3-A7	SIG BUS CONT	W	B-20	CH. 14 RED	14R-A	OLB RED
X	A-21	OUT RLY 2 COM.	A-27	LOGIC GND	X	B-21	CH. 15 RED	15R-A	OLC RED
Y	A-22	CH. 12 YELLOW	12Y-A	VEH. 7 FYA	Y	B-22	CH. 16 RED	16R-A	OLD RED
Z	A-23	CH. 11 YELLOW	11Y-A	VEH. 5 FYA	Z	B-23	CH. 3 RED	3R-A	^3 RED
a	A-24	CH. 10 WALK	----		a	B-24	RED ENABLE	LS8-1	SIG BUS CON.
b	A-25	CH. 10 YELLOW	10Y-A	VEH. 3 FYA	b	B-25	(SPARE 3)	B31	
c	A-26	CH. 9 YELLOW	9Y-A	VEH. 1 FYA	c	B-26	LOCAL FLASH IN	A32	POL/AX FLSH
d	A-27	CH. 8 YELLOW	8Y-A	^8 YEL		B-27	SHELL GROUND	LS6-2	EARTH GND.
e	A-28	CH. 7 YELLOW	7Y-A	^7 YEL					
f	A-29	CH. 6 YELLOW	6Y-A	^6 YEL					
g	A-30	CH. 5 YELLOW	5Y-A	^5 YEL					
h	A-31	CH. 3 YELLOW	3Y-A	^3 YEL					
i	A-32	CH. 15 GREEN	15G-A	OLC GRN					
j	A-33	CH. 2 YELLOW	2Y-A	^2 YEL					
k	A-34	CH. 1 YELLOW	1Y-A	^1 YEL					
m	A-35	CONT. VOLT. MON.	B-5	VOLT. MON.					
n	A-36	+24V MON. INH.	B-2						
p	A-37	OUT RLY 1 CLSD	J3-A3						
q	A-38	OUT RLY 2 OPEN	A-31	STOP TIME					
r	A-39	CH. 12 WALK	----						
s	A-40	CH. 11 WALK	----						
t	A-41	CH. 9 WALK	----						
u	A-42	CH. 16 YELLOW	16Y-A	OLD YEL					
v	A-43	CH. 15 YELLOW	15Y-A	OLC YEL					
w	A-44	CH. 13 YELLOW	13Y-A	OLA YEL					
x	A-45	CH. 4 YELLOW	4Y-A	^4 YEL					
y	A-46	CH. 14 GREEN	14G-A	OLB GRN					
z	A-47	CH. 13 GREEN	13G-A	OLA GRN					
AA	A-48	(SPARE 1)	B24						
BB	A-49	RESET	B-1						
CC	A-50	CAB. INTLK A	B25						
DD	A-51	CAB. INTLK B	B26						
EE	A-52	CH. 14 YELLOW	14Y-A	OLB YRL					
FF	A-53	CH. 16 GREEN	16G-A	OLD GRN					
GG	A-54	(SPARE 2)	B27						
HH	A-55	TYPE SELECT	A-20	MMU/CMU SEL.					
	A-56	SHELL GND	LS15-2	EARTH GND.					

#### NOTES FOR 16 CHANNEL M.M.U.

- (1) RELAY CONTACT POSITIONS SPECIFIED ARE FOR NON-CONFLICT MODE.
- (2) TO PROGRAM MMU, SOLDER JUMPERS IN PROGRAMMING CARD FOR ALL PERMISSABLE PHASE MOVEMENTS, MINIMUM CHANGE DISABLE FOR ALL PEDESTRIAN CHANNELS, AND MIN. FLASH, VOLTAGE MON., AND 24V. MON. LATCH OPTIONS AS DESIRED.

#### M.M.U. CHANNEL ASSIGNMENTS

CH. 1 =	L/S 1 =	^1 VEH.
CH. 2 =	L/S 2 =	^2 VEH.
CH. 3 =	L/S 3 =	^3 VEH.
CH. 4 =	L/S 4 =	^4 VEH.
CH. 5 =	L/S 5 =	^5 VEH.
CH. 6 =	L/S 6 =	^6 VEH.
CH. 7 =	L/S 7 =	^7 VEH.
CH. 8 =	L/S 8 =	^8 VEH.
CH. 9 =	L/S 9 =	^2 PED. / VEH. 1 FYA
CH. 10 =	L/S 10 =	^4 PED. / VEH. 3 FYA
CH. 11 =	L/S 11 =	^6 PED. / VEH. 5 FYA
CH. 12 =	L/S 12 =	^8 PED. / VEH. 7 FYA
CH. 13 =	L/S 13 =	O'LAP A VEH.
CH. 14 =	L/S 14 =	O'LAP B VEH.
CH. 15 =	L/S 15 =	O'LAP C VEH.
CH. 16 =	L/S 16 =	O'LAP D VEH.

### MMU PROGRAM CARD

RENO A&E

### M.M.U. C/C'S AND PROGRAM CARD



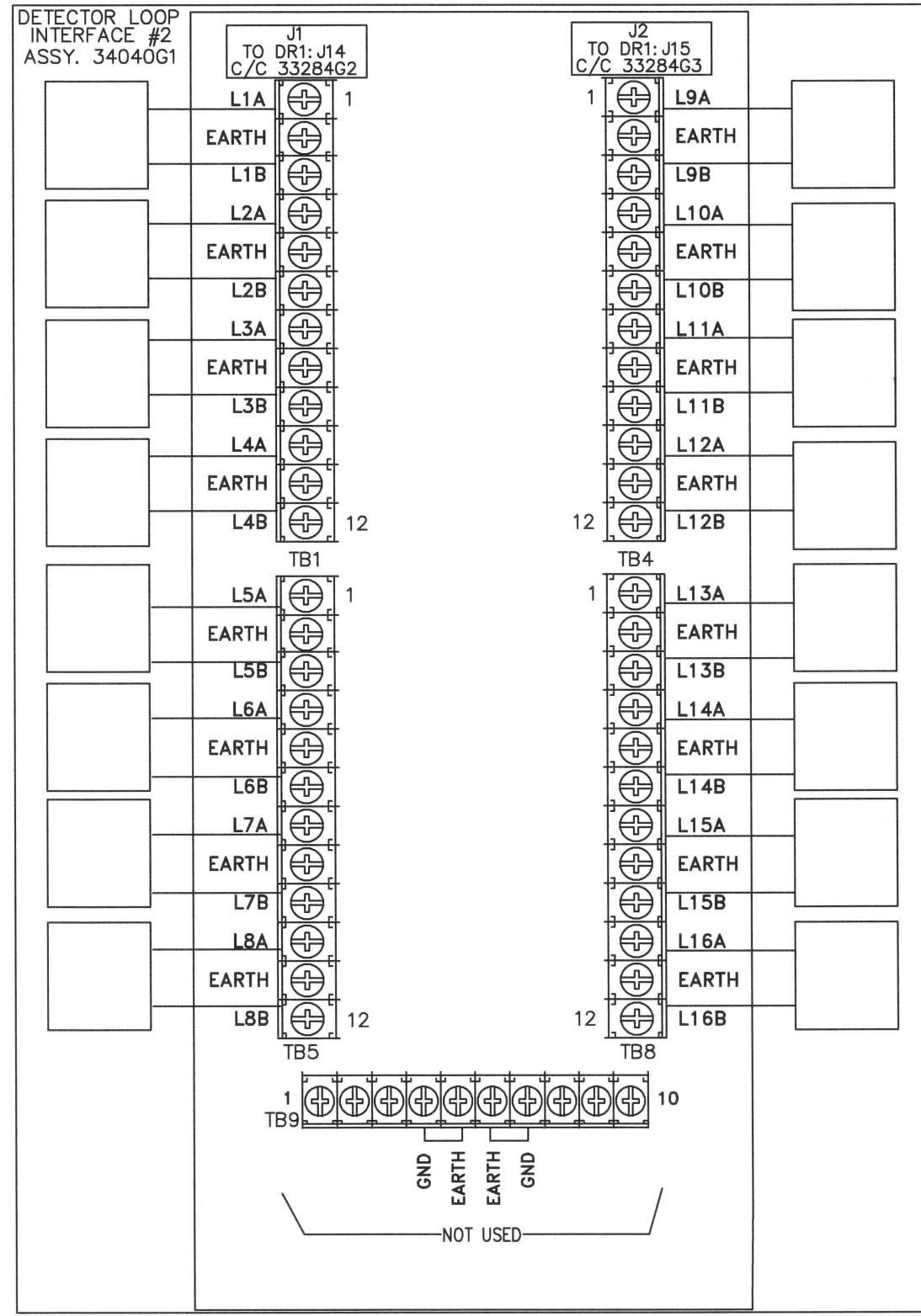
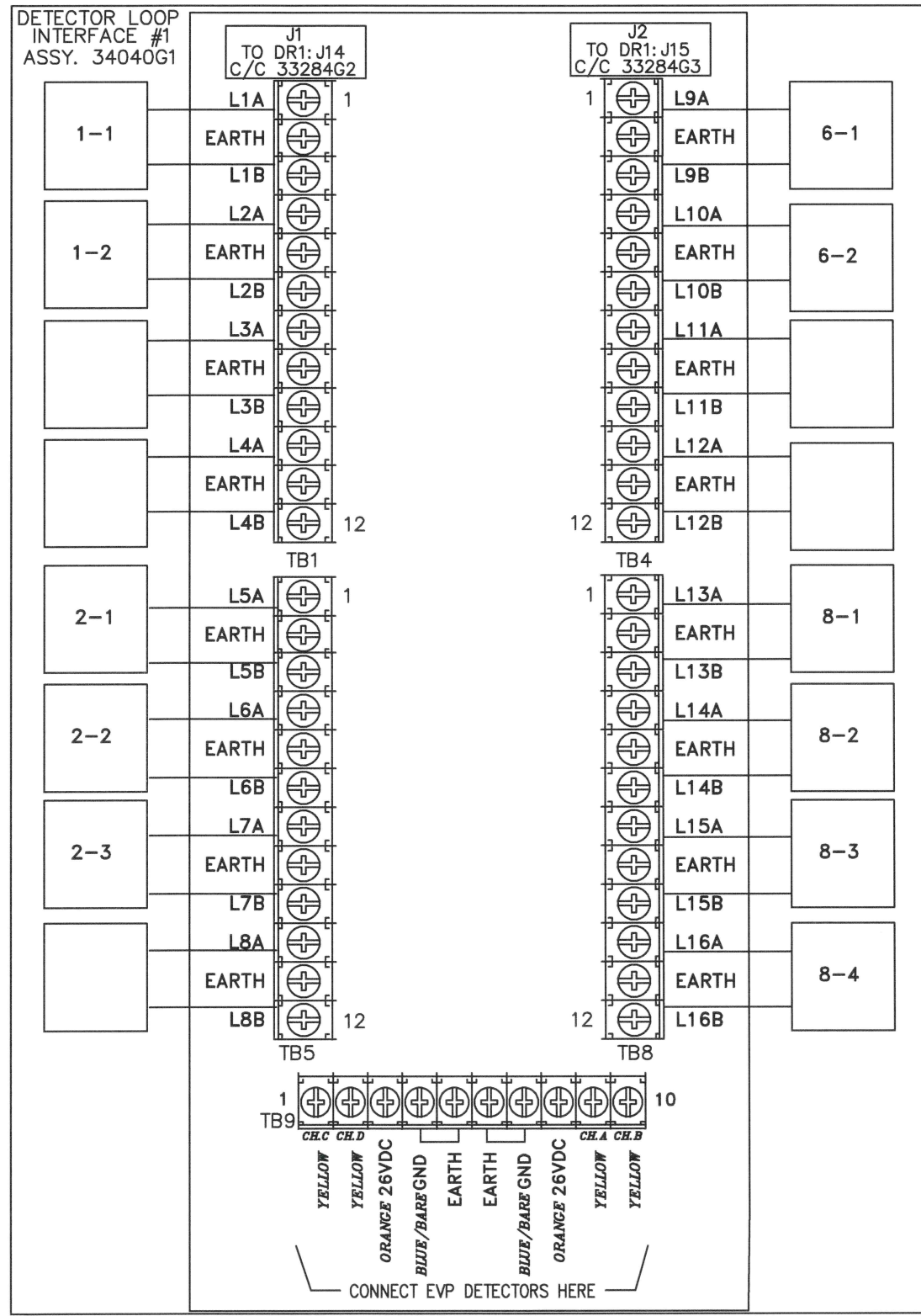

DET. LOOPS 1-8 (J14) C/C 33284G2

PIN	SIGNAL	TO
1	LOOP 1+	LPI1: TB1-1
2	LOOP 1-	LPI1: TB1-3
3	LOOP 2+	LPI1: TB1-4
4	LOOP 2-	LPI1: TB1-6
5	LOOP 3+	LPI1: TB1-7
6	LOOP 3-	LPI1: TB1-9
7	LOOP 4+	LPI1: TB1-10
8	LOOP 4-	LPI1: TB1-12
9	LOOP 5+	LPI1: TB5-1
10	LOOP 5-	LPI1: TB5-3
11	LOOP 6+	LPI1: TB5-4
12	LOOP 6-	LPI1: TB5-6
13	LOOP 7+	LPI1: TB5-7
14	LOOP 7-	LPI1: TB5-9
15	LOOP 8+	LPI1: TB5-10
16	LOOP 8-	LPI1: TB5-12
17	PMT. DET. CH. C	LPI1: TB9-1
18	PMT. DET. CH. D	LPI1: TB9-2
19	KEY PIN	
20	PMT. CH. C/D +26VDC	LPI1: TB9-3
21	PMT. DC GROUND	LPI1: TB9-4,7
22	PMT. CH. A/B +26VDC	LPI1: TB9-8
23	PMT. DET. CH. A	LPI1: TB9-9
24	PMT. DET. CH. B	LPI1: TB9-10
25	----	
26	----	

DET. LOOPS 9-16 (J15) C/C 33284G3

PIN	SIGNAL	TO
1	LOOP 9+	LPI2: TB4-1
2	LOOP 9-	LPI2: TB4-3
3	LOOP 10+	LPI2: TB4-4
4	LOOP 10-	LPI2: TB4-6
5	LOOP 11+	LPI2: TB4-7
6	LOOP 11-	LPI2: TB4-9
7	LOOP 12+	LPI2: TB4-10
8	LOOP 12-	LPI2: TB4-12
9	LOOP 13+	LPI2: TB8-1
10	LOOP 13-	LPI2: TB8-3
11	LOOP 14+	LPI2: TB8-4
12	LOOP 14-	LPI2: TB8-6
13	LOOP 15+	LPI2: TB8-7
14	LOOP 15-	LPI2: TB8-9
15	LOOP 16+	LPI2: TB8-10
16	LOOP 16-	LPI2: TB8-12
17	----	
18	----	
19	----	
20	----	

DET. RACK POWER  
171-1676-515

P1/ DR: J13	P2/ DR: J17	FUNCTION	TO
1		+12 VDC (DET. POWER)	PB-3
2		+24 VDC (BIU POWER)	PB-2
3		LOGIC GROUND	PB-1
4		EARTH GROUND	PB-9
5		"KEY PIN"	
6		LINE FREQUENCY REF.	PB-5
	1	EARTH GROUND	----
	2	AC LINE	PB-12
	3	AC NEUTRAL	PB-10
	4	LOGIC GROUND	----

EXPANSION OUTPUTS  
C/C 33284G84

J16	FUNCTION	TO
17	DET. 17 / PMT. A OUT	MP: B19
18	DET. 18 / PMT. B OUT	MP: B20
19	PMT. C OUT	MP: B17
20	PMT. D OUT	MP: B18

RACK #1 ONLY

# DETECTOR LOOP INTERFACE

<b>B.I.U</b>	DET	PH	F	DET	DLY	EXT	DET	PH	F	DET	DLY	EXT	DET	PH	F	DET	DLY	EXT	DET	PH	F	DET	DLY	EXT	EVP	PH	POLE #	CONT CH #
	CH 1	1	1	1-1			CH 5	2	1	2-1			CH 9	6	1	6-1			CH 13	8	3	8-1			CH 1	1-6	3	3
	CH 2	1	1	1-2			CH 6	2	1	2-2			CH 10	6	1	6-2			CH 14	8	3	8-2			CH 2	2	1	4
	CH 3						CH 7	2	1	2-3			CH 11						CH 15	8	7	8-3			CH 3	8	4	5
	CH 4						CH 8						CH 12						CH 16	8	1	8-4			CH 4			

<b>B.I.U</b>	DET	PH	F	DET	DLY	EXT	DET	PH	F	DET	DLY	EXT	DET	PH	F	DET	DLY	EXT	DET	PH	F	DET	DLY	EXT				
	CH 17						CH 21						CH 25						CH 29									
	CH 18						CH 22						CH 26						CH 30									
	CH 19						CH 23						CH 27						CH 31									
	CH 20						CH 24						CH 28						CH 32									

