

MAIN PANEL:171-1081-504

COBALT TS2 TYPE 2 CONTROLLER WITH:

LEGEND

CONTROLLER PART # F51674

- CONFIGURATION: L3604
- SOFTWARE: EOS
- ETHERNET MODULE

□ OVERLAPS

A =
 B =
 C =
 D =
 E =
 F =
 G =
 H =

- TELEMETRY MODULE
- INTERNAL RS-232 TELEMETRY

BIU BUS INTERFACE UNIT
 BU() C/C, BIU ()
 CB() CIRCUIT BREAKER ()
 C/C CONNECTING CABLE
 CCA CONTROLLER CABLE "A"
 CDP C/C, DR POWER
 CMA MMU/CMU CABLE "A"
 CMB MMU/CMU CABLE "B"
 CPO C/C PRE-EMPT OUTPUTS
 CPP C/C PRE-EMPT POWER
 DR DETECTOR RACK
 DS() DOOR SWITCH ()
 FL() FLASHER ()
 FR() FLASH XFER. RELAY
 LS() LOAD SWITCH
 MC MERCURY CONTACTOR
 MP MAIN PANEL
 PAP POWER-AUX PANEL
 PSP CAB. PWR. SUPPLY
 SA SURGE ARRESTOR
 TB-() TERM. BLOCK ()

FLASHER	
PIN	FUNCTION
7	CIRCUIT #1
8	CIRCUIT #2
9	CHASSIS GND
10	AC COMMON
11	115 VAC
12	-----

LOAD SWITCH	
PIN	FUNCTION
1	115 VAC
2	CHASSIS GND
3	RED/DW OUTPUT
4	-----
5	YEL OUTPUT
6	RED/DW INPUT
7	YEL INPUT
8	GRN/W OUTPUT
9	+24 VDC
10	GRN/W INPUT
11	AC COMMON
12	-----

① 2.2K 10W

3 USE ONLY COPPER CONDUCTORS FOR FIELD AND SERVICE CONNECTIONS.

2 CONNECT A.C. SERVICE TO TERMINAL BLOCK 501 (LINE), 502 (NEUTRAL) AND GB2 (EARTH) ON RIGHT SIDEWALL OF CABINET.

① INSTALL 2.2K, 10 WATT LOAD RESISTORS BETWEEN PINS 7 AND 11 ON LOAD SWITCHES 9, 10, 11 & 12.

NOTES: UNLESS SPECIFIED OTHERWISE

MAIN PANEL PLUG-IN REQUIREMENTS

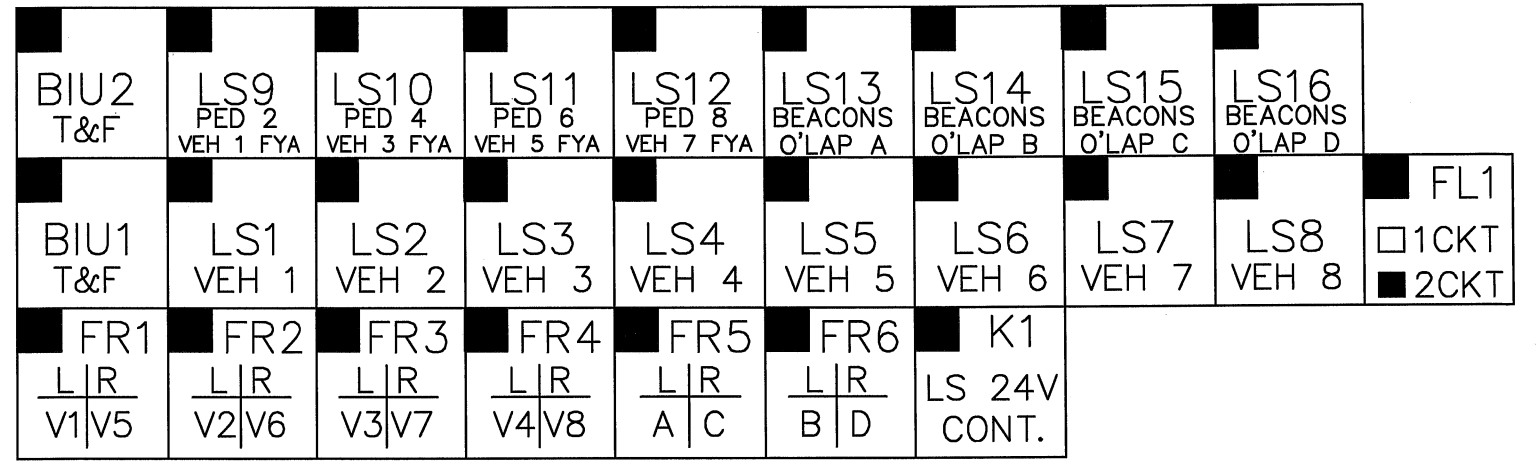

■ DENOTES TYPE OF OPERATION AND/OR WHERE PLUG-IN IS REQUIRED. L = LEFT, R = RIGHT.

⊠ DENOTES WHERE "UNUSED RED" JUMPER PART NUMBER 32448G1 IS REQUIRED. INSTALL BETWEEN PINS 1 & 3 FOR LOAD SWITCH OR PINS 6 & 8 AND 5 & 7 FOR FLASH TRANSFER RELAY.

FLASH:

- ø2&6 YELLOW, ALL OTHERS RED.
- ALL RED.
- RELAYS DE-ENERGIZED FOR FLASH.
- RELAYS ENERGIZED FOR FLASH.

120V+	950	TB2-12(BLK)
120V-	951	TB2-10(WHT)
120V-	952	
2W	953	-9G-A (RED-9C)
2DW	954	-9R-A (BLK-9C)
4W	955	-10G-A (BLU-9C)
4DW	956	-10R-A (BRN-9C)
6W	957	-11G-A (ORG-9C)
6DW	958	-11R-A (YEL-9C)
8W	959	-12G-A (PUR-9C)
8DW	960	-12R-A (WHT-9C)
SPARE	961	
SPARE	962	
GRND	963	TB2-9 (GRN)
GRND	964	
PC-2	965	-PC2-A (RED-4C)
PC-4	966	-PC4-A (BLK-4C)
PC-6	967	-PC6-A (GRN-4C)
PC-8	968	-PC8-A (WHT-4C)
SPARE	969	

PEDESTRIAN PUSHBUTTON/SIGNAL INTERFACE

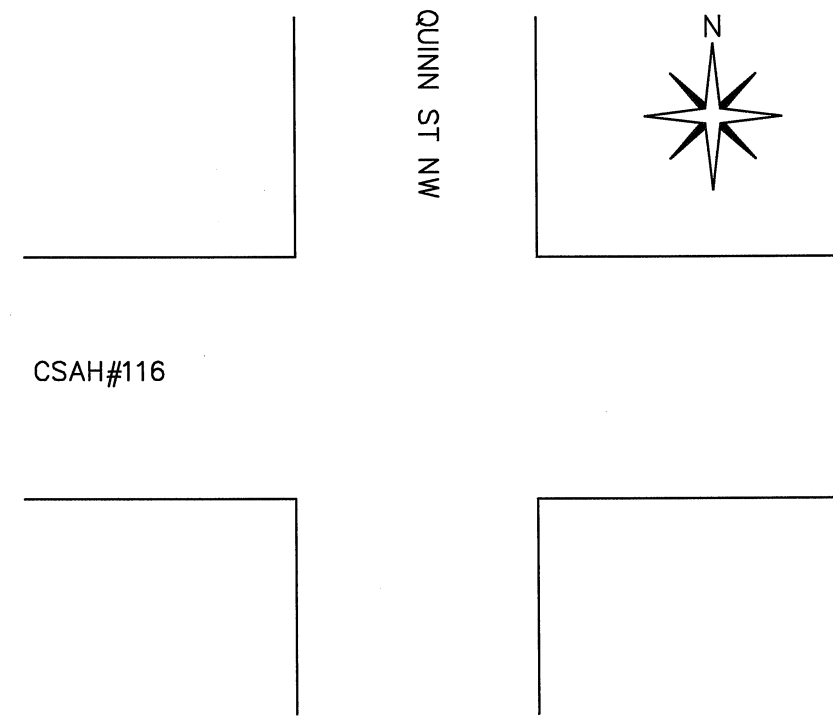

SHEET 1 OF 7

DRAWN CM TCC	1/10/2024
CABINET SIZE	77"
INSPECTED	
APPROVED	

ECONOLITE CONTROL PRODUCTS INC.	TRAFFIC CONTROL CORPORATION 10435 ARGONNE WOODS DR. WOODRIDGE, IL 60517		
		CABINET SPECIFICATION: TS2TYPE1 ANOKA COUNTY SPEC PLUG AND GO	
CUSTOMER: ANOKA COUNTY	CONTROLLER		
INTERSECTION: CSAH#116 AT QUINN ST NW	FLASHER		
LOCATION:	SW.PACKS		
SYSTEM:			
CUSTOMER P.O. 0008128	INSTALLED BY ANOKA COUNTY HIGHWAY DEPARTMENT	SALES ORDER NO. 737892	DRAWING # 655397-1

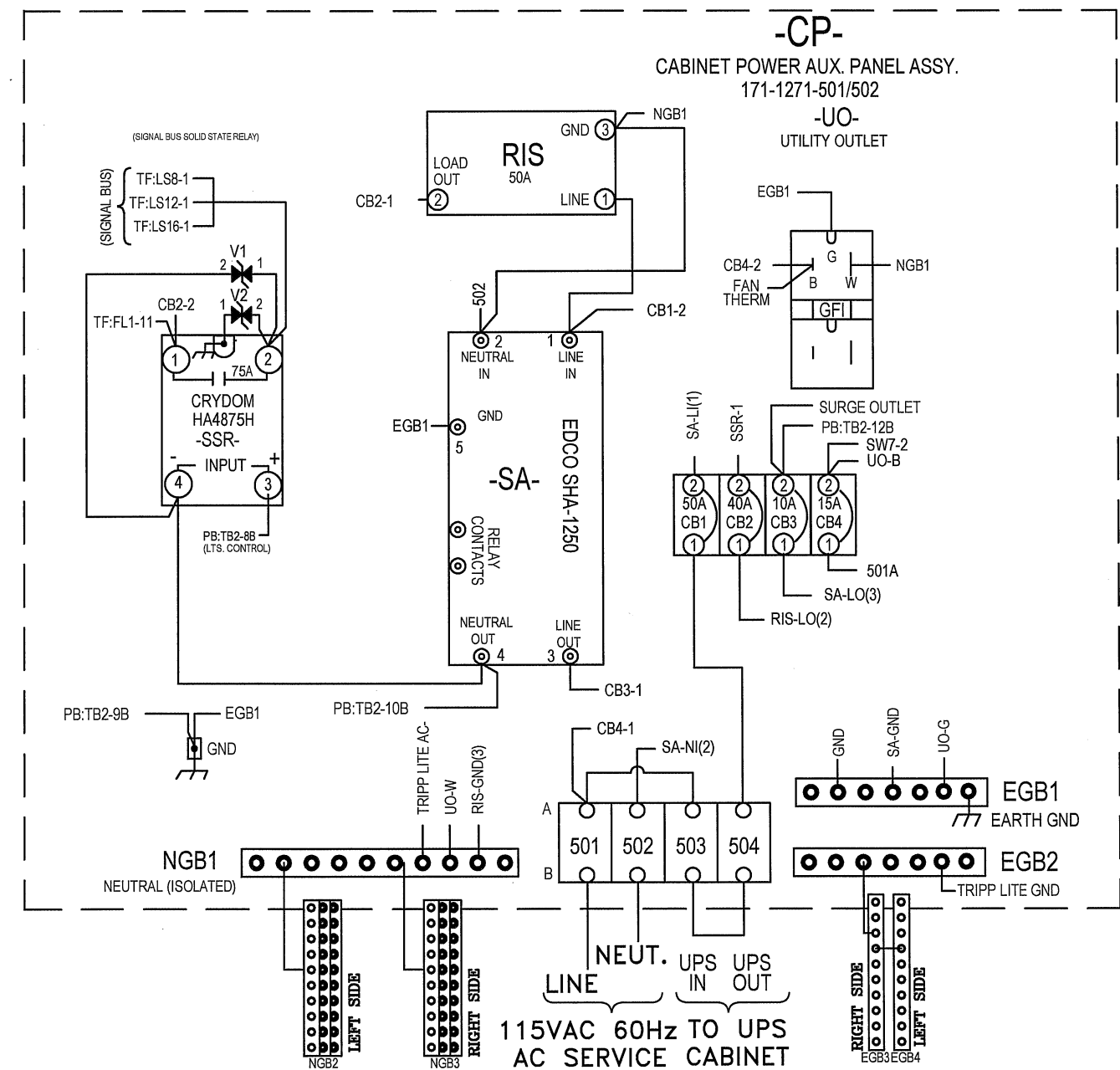
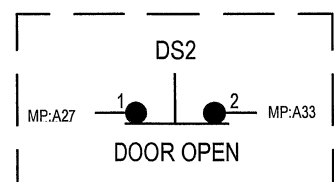
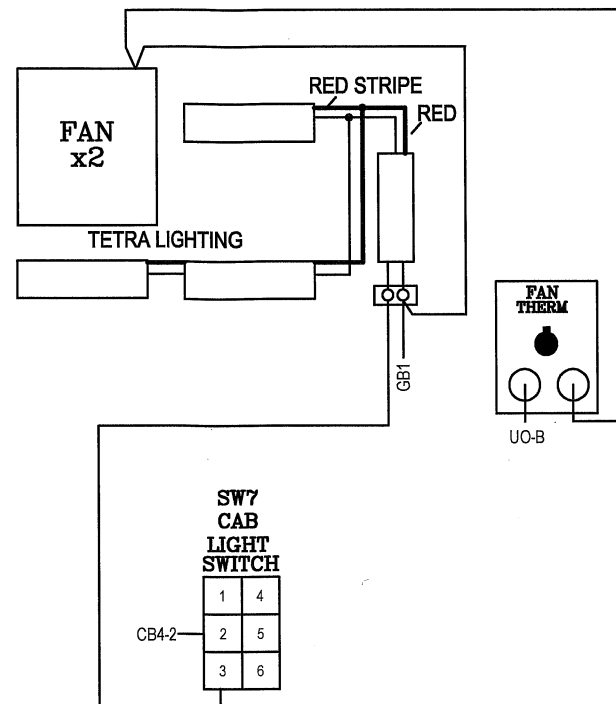
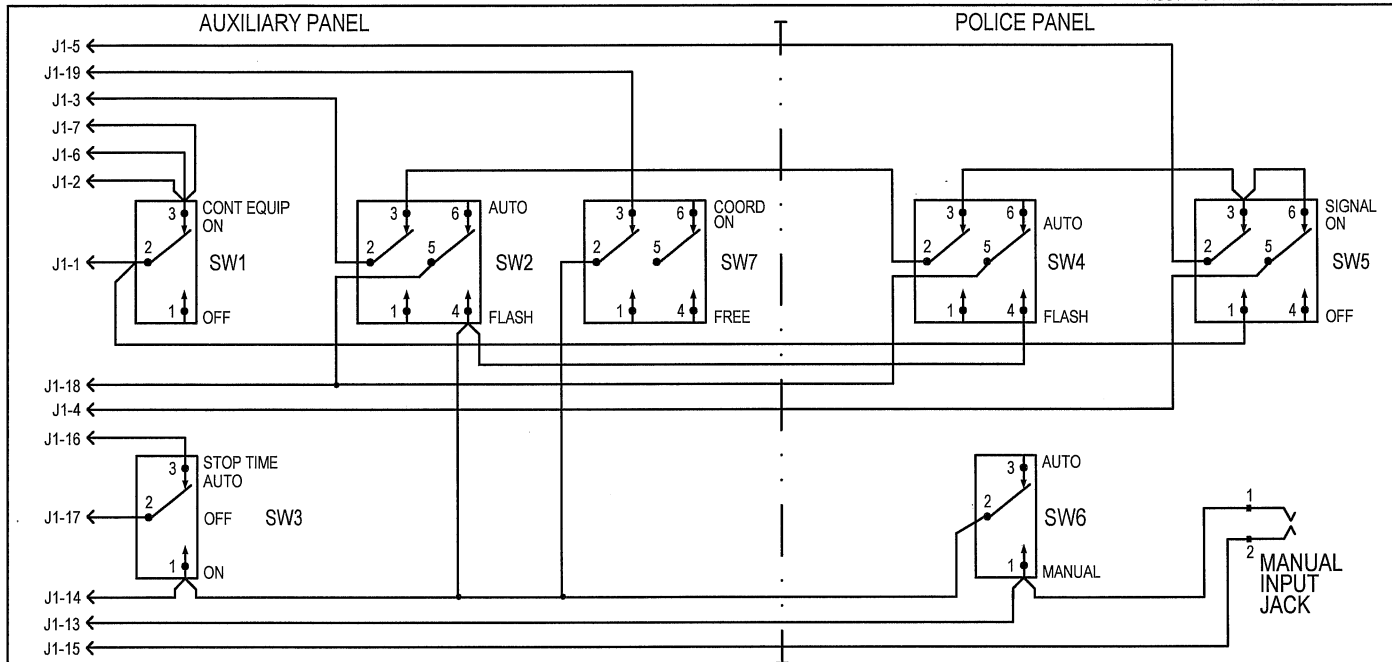

- J3
- J3-36 1
- MMB-1 2
- MMA-37 3
- K1-10 4
- FR6-2 5
- MMB-2 6
- MMA-20 7
- 8
- 9
- 10
- 11
- 12
- A-39 13
- A-35 14
- A-40 15
- A-31 16
- A-30 17
- A-32 18
- A-38 19
- A-33 20
- A-34 21
- K1-9 22
- B-3 23
- B-4 24
- A-35 25
- K1-11 26
- 27
- B-5 28
- J1-31B 29
- J1-27B 30
- K1-10 31
- 32
- K1-2 33
- 34
- MMB-18 35
- J3-1 36
- (N/U) 37

(MAIN PANEL & C/C REFERENCES ONLY)

TO/FROM POLICE-AUXILIARY SWITCH PANEL	
PIN	FUNCTION
1	FILTER AC LINE (OUT)
2	SWITCHED AC LINE (IN)
3	FLASH CONTROL BUS (OUT)
4	SIGNAL BUS CONTROL (IN)
5	FLASH RELAY CONTROL (IN)
6	START DELAY AC BUS (IN)
7	MMU FLASH CONTROL BUS (IN)
8	SPARE
9	SPARE
10	SPARE
11	SPARE
12	SPARE
13	MANUAL CONT. ENABLE (IN)
14	LOGIC GROUND
15	OPT-INTERVAL ADVANCE (IN)
16	MMU STOP TIME (OUT)
17	CONTROLLER STOP TIME (IN)
18	LOCAL FLASH STATUS (IN)
19	OPT-COORD FREE (IN)
20	OPT-ALARM 1 (IN)
21	COORD FREE (IN)
22	ALARM 1 (IN)
23	ALARM 2 (IN)
24	LOADSWITCH TEST (IN)
25	MMU 24 VOLT MON. 2 (IN)
26	+24 VDC
27	LOGIC GROUND
28	+24 VDC (IN)
29	MMU FAULT MONITOR (IN)
30	LINE FREQ. REFERENCE (IN)
31	12 VAC (IN)
32	SIGNAL BUS CONTROL (IN)
33	---
34	FILTERED AC NEUTRAL (IN)
35	CONT. EQUIP. AC LINE (OUT)
36	FILTERED AC LINE (IN)
37	---

MP P3	MAIN PANEL/CONTROLLER PWR. C/C 171-1676-504	TO POL/AUX P1
PIN	FUNCTION	PIN
1	FILTER AC LINE (OUT)	1
2	SWITCHED AC LINE (IN)	2
3	FLASH CONTROL BUS (OUT)	3
4	SIGNAL BUS CONTROL (IN)	4
5	FLASH RELAY CONTROL (IN)	5
6	START DELAY AC BUS (IN)	6
7	MMU FLASH CONTROL BUS (IN)	7
8	SPARE	8
9	SPARE	9
10	SPARE	10
11	SPARE	11
12	SPARE	12
13	OPT-MANUAL CONT. ENABLE (IN)	13
14	LOGIC GROUND	14
15	OPT-INTERVAL ADVANCE (IN)	15
16	MMU STOP TIME (OUT)	16
17	CONTROLLER STOP TIME (IN)	17
18	LOCAL FLASH STATUS (IN)	18
19	OPT-COORD FREE (IN)	19
20	OPT-ALARM 1 (IN)	20
21	COORD FREE (IN)	21
22	ALARM 1 (IN)	22
23	ALARM 2 (IN)	23
24	LOADSWITCH TEST (IN)	24
PART OF 171-1076-504 TO PB:(X)		
25	LOGIC GROUND	1
26	+24 VDC (IN)	2
(N/U)	---	3
28	MMU FAULT MONITOR (IN)	4
29	LINE FREQ. REFERENCE (IN)	5
(N/U)	---	6
31	12 VAC (IN)	7
32	SIGNAL BUS CONTROL (IN)	8
(N/U)	---	9
34	FILTERED AC NEUTRAL (IN)	10
35	CONT. EQUIP. AC LINE (OUT)	11
36	FILTERED AC LINE (IN)	12
(N/U)	---	13
(N/U)	---	14

POLICE/AUXILIARY SWITCH PANEL		
J1 PIN	FUNCTION	TO
1	FILTER AC LINE (IN)	SW1-2
2	SWITCHED AC LINE (OUT)	SW1-3
3	FLASH CONTROL BUS (IN)	SW2-2
4	SIGNAL BUS CONTROL (OUT)	SW5-5
5	FLASH RELAY CONTROL (OUT)	SW5-2
6	START DELAY BUS (OUT)	SW1-3
7	MMU FLASH CONTROL BUS (OUT)	SW1-3
8	SPARE	---
9	SPARE	---
10	SPARE	---
11	SPARE	---
12	SPARE	---
13	MANUAL CONT. ENABLE (OUT)	SW6-1
14	LOGIC GROUND	SW3-1
15	INTERVAL ADVANCE (OUT)	MJ-2
16	MMU STOP TIME (IN)	SW3-3
17	CONTROLLER STOP TIME (OUT)	SW3-2
18	LOCAL FLASH STATUS (OUT)	SW2-5
19	COORD FREE (OUT)	---
20	ALARM 1 (OUT)	---
21	ALARM 2 (OUT)	---
22	LOADSWITCH TEST (OUT)	---
23	MMU 24 VOLT MON. 2 (OUT)	---
24	+24 VDC (IN)	---

CONFIRMATION BEACONS

- EVP 3 = 1-6
- EVP 4 = 2-5
- EVP 5 = 3-8
- EVP 6 = 4-7

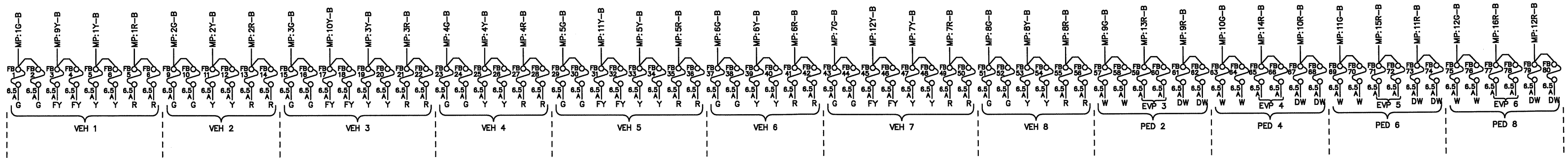
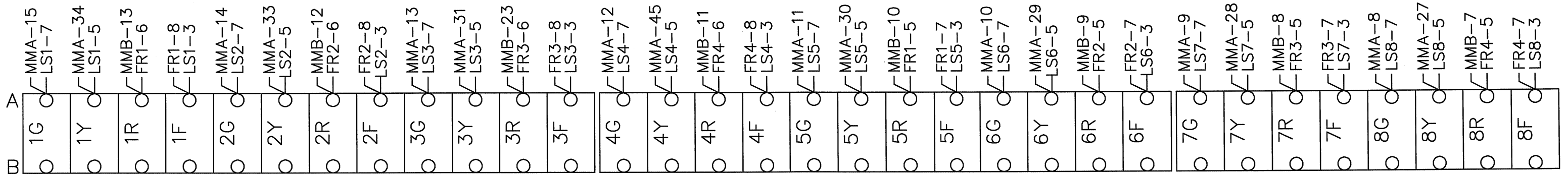
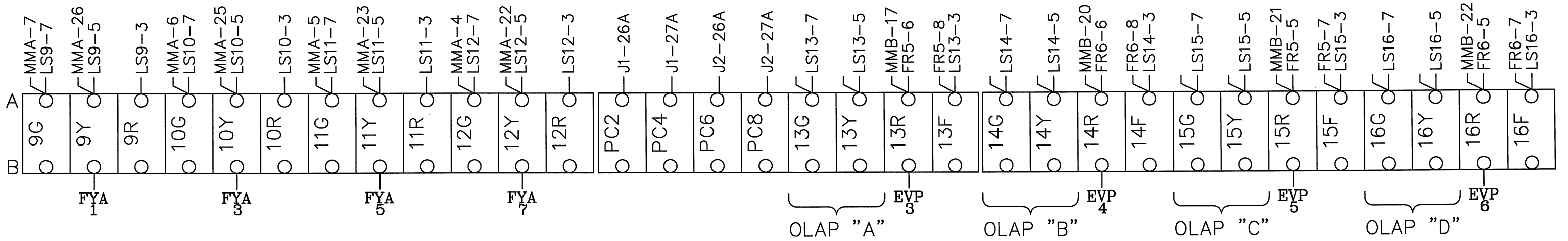

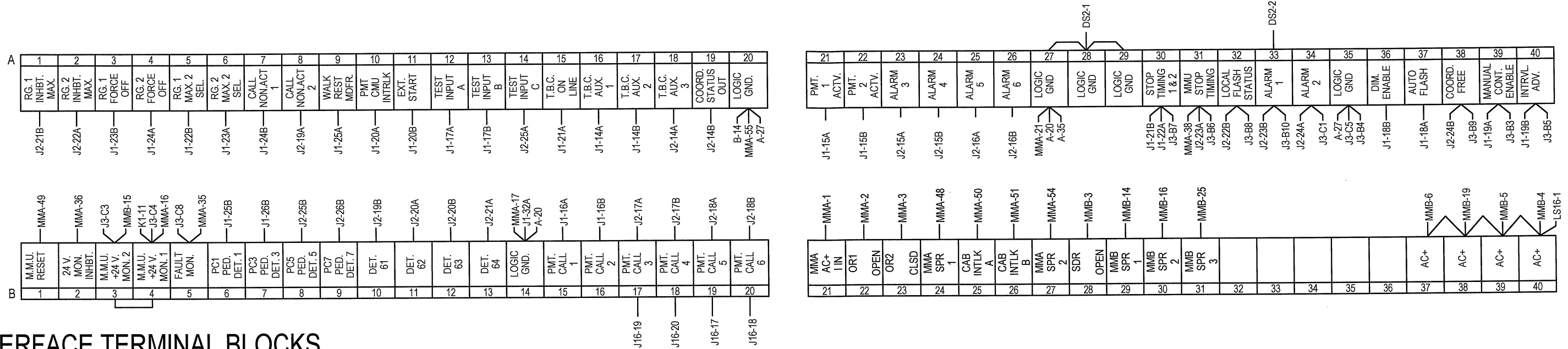

INTERFACE TERMINAL BLOCKS

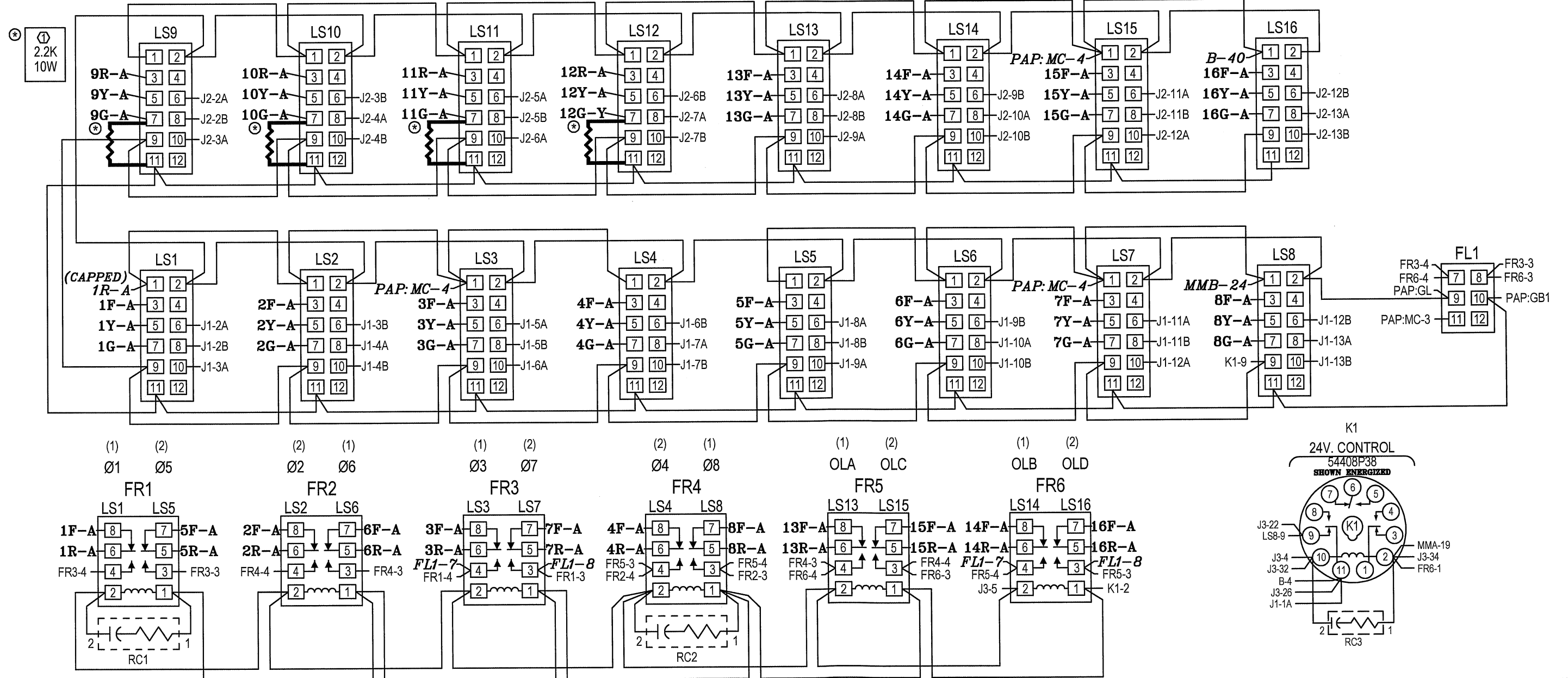

J1 BIU #1		
PIN	FUNCTION	TO
1A	+24 VDC	K1-11
1B	+24 VDC	J2-1B
2A	LS1 RED	LS1-6
2B	LS1 YELLOW	LS1-8
3A	LS1 GREEN	LS1-10
3B	LS2 RED	LS2-6
4A	LS2 YELLOW	LS2-8
4B	LS2 GREEN	LS2-10
5A	LS3 RED	LS3-6
5B	LS3 YELLOW	LS3-8
6A	LS3 GREEN	LS3-10
6B	LS4 RED	LS4-6
7A	LS4 YELLOW	LS4-8
7B	LS4 GREEN	LS4-10
8A	LS5 RED	LS5-6
8B	LS5 YELLOW	LS5-8
9A	LS5 GREEN	LS5-10
9B	LS6 RED	LS6-6
10A	LS6 YELLOW	LS6-8
10B	LS6 GREEN	LS6-10
11A	LS7 RED	LS7-6
11B	LS7 YELLOW	LS7-8
12A	LS7 GREEN	LS7-10
12B	LS8 RED	LS8-6
13A	LS8 YELLOW	LS8-8
13B	LS8 GREEN	LS8-10
14A	TBC AUX 1	A-16
14B	TBC AUX 2	A-17
15A	PMT ACT 1	A-21
15B	PMT ACT 2	A-22
16A	PMT CALL 1	B-15
16B	PMT CALL 2	B-16
17A	TEST A	A-12
17B	TEST B	A-13
18A	AUTO FLASH	A-37
18B	DIM. ENABLE	A-36
19A	MANUAL CONT.	A-39
19B	INT. ADVANCE	A-40
20A	EXT. MIN. RECALL	A-10
20B	EXT. START	A-11
21A	TBC ONLINE	A-15
21B	STOP TIME (1)	A-30
22A	STOP TIME (2)	A-30
22B	MAX. 2 (1)	A-5
23A	MAX. 2 (2)	A-6
23B	FORCE OFF (1)	A-3
24A	FORCE OFF (2)	A-4
24B	CNA 1	A-7
25A	WALK REST MOD.	A-9
25B	PED. ISO. 1	B-6
26A	PED. ISO. 2	PC2-A
26B	PED. ISO. 3	B-7
27A	PED. ISO. 4	PC4-A
27B	PED. ISO. COMN.	J3-D1
28A	ADDR. SEL. 0	---
28B	ADDR. SEL. 1	---
29A	ADDR. SEL. 2	---
29B	ADDR. SEL. 3	---
30A	RESERVED	---
30B	RESERVED	---
31A	EARTH GND.	LS12-2
31B	LINE FREQ. REF.	J3-C9
32A	LOGIC GND.	B-14
32B	LOGIC GND.	J2-32A

J2 BIU #2		
PIN	FUNCTION	TO
1A	+24 VDC	J2-1B
1B	+24 VDC	J1-1B
2A	LS9 RED	LS9-6
2B	LS9 YELLOW	LS9-8
3A	LS9 GREEN	LS9-10
3B	LS10 RED	LS10-6
4A	LS10 YELLOW	LS10-8
4B	LS10 GREEN	LS10-10
5A	LS11 RED	LS11-6
5B	LS11 YELLOW	LS11-8
6A	LS11 GREEN	LS11-10
6B	LS12 RED	LS12-6
7A	LS12 YELLOW	LS12-8
7B	LS12 GREEN	LS12-10
8A	LS13 RED	LS13-6
8B	LS13 YELLOW	LS13-8
9A	LS13 GREEN	LS13-10
9B	LS14 RED	LS14-6
10A	LS14 YELLOW	LS14-8
10B	LS14 GREEN	LS14-10
11A	LS15 RED	LS15-6
11B	LS15 YELLOW	LS15-8
12A	LS15 GREEN	LS15-10
12B	LS16-RED	LS16-6
13A	LS16-YELLOW	LS16-8
13B	LS16-GREEN	LS16-10
14A	TBC AUX 3	A-18
14B	COORD. STATUS	A-19
15A	ALARM 3	A-23
15B	ALARM 4	A-24
16A	ALARM 5	A-25
16B	ALARM 6	A-26
17A	PMT CALL 3	B-17
17B	PMT CALL 4	B-18
18A	PMT CALL 5	B-19
18B	PMT CALL 6	B-20
19A	CNA 2	A-8
19B	SPARE 1	B-10
20A	SPARE 2	B-11
20B	SPARE 3	B-12
21A	SPARE 4	B-13
21B	INHIBIT MAX (1)	A-1
22A	INHIBIT MAX (2)	A-2
22B	LOCAL FLASH	A-32
23A	MMU FLASH	A-31
23B	ALARM 1	A-33
24A	ALARM 2	A-34
24B	COORD FREE IN	A-38
25A	TEST C	A-14
25B	PED. ISO. 5	B-8
26A	PED. ISO. 6	PC6-A
26B	PED. ISO. 7	B-9
27A	PED. ISO. 8	PC8-A
27B	PED. ISO. COMN.	J1-27B
28A	ADDR. SEL. 0	J2-32A
28B	ADDR. SEL. 1	---
29A	ADDR. SEL. 2	---
29B	ADDR. SEL. 3	---
30A	RESERVED	---
30B	RESERVED	---
31A	EARTH GND.	J1-31A
31B	LINE FREQ. REF.	J1-31B
32A	LOGIC GND.	J1-32B
32B	LOGIC GND.	J2-32A

DETECTOR BIU		
PIN	FUNCTION	TO
1A	+24 VDC	---
1B	+24 VDC	---
2A	---	---
2B	---	---
3A	---	---
3B	---	---
4A	---	---
4B	---	---
5A	---	---
5B	---	---
6A	---	---
6B	---	---
7A	---	---
7B	---	---
8A	---	---
8B	---	---
9A	---	---
9B	---	---
10A	---	---
10B	---	---
11A	---	---
11B	---	---
12A	---	---
12B	---	---
13A	---	---
13B	---	---
14A	---	---
14B	---	---
15A	---	---
15B	---	---
16A	---	---
16B	---	---
17A	---	---
17B	---	---
18A	---	---
18B	---	---
19A	---	---
19B	---	---
20A	---	---
20B	---	---
21A	---	---
21B	---	---
22A	---	---
22B	---	---
23A	---	---
23B	---	---
24A	---	---
24B	---	---
25A	---	---
25B	---	---
26A	---	---
26B	---	---
27A	---	---
27B	---	---
28A	---	---
28B	---	---
29A	---	---
29B	---	---
30A	---	---
30B	---	---
31A	---	---
31B	---	---
32A	---	---
32B	---	---

MAIN PANEL CONTROL POWER C/C 171-1676-504	
PIN	FUNCTION
1	LOGIC GND
2	+24 VDC (IN)
3	---
4	MMU FAULT MONITOR (IN)
5	LINE FREQ. REFERENCE (IN)
6	---
7	+12 VAC (IN)
8	SIGNAL BUS CONTROL (IN)
9	---
10	FILTERED AC NEUTRAL (IN)
11	CONT. EQUIP. AC LINE (OUT)
12	FILTERED AC LINE (IN)
13	---
14	---

CONTROLLER POWER (CCA2) C/C 171-1676-503			
WIRE	PIN	SIGNAL	TO
1	A	FAULT MONITOR	PB-4
2	U	AC NEUTRAL	PB-10
3	V	EARTH GROUND	PB-9
4	W	LOGIC GROUND	PB-1
5	P	AC LINE	PB-11
6	SHL	EARTH GROUND	CCA2-V

TYPE 1 CONTROLLER POWER C/C 171-1676-502		
PIN	FUNCTION	TO
A	AC NEUTRAL	PB-10
B	---	---
C	AC LINE	PB-11
D	---	---
E	---	---
F	FAULT MON.	PB-4
G	LOGIC GND.	PB-1
H	EARTH GND.	PB-9
I	---	---
J	---	---
SHL	EARTH GND.	PB-6

CABINET POWER SUPPLY C/C 171-1676-511		
PIN	FUNCTION	TO
A	AC NEUTRAL	PB-10
B	LINE FREQUENCY REF.	PB-5
C	AC LINE	PB-11
D	+12 VDC	PB-3
E	+24 VDC	PB-2
F	RESERVED	---
G	LOGIC GND.	PB-1
H	EARTH GND.	PB-9
I	+12 VAC	PB-7
J	RESERVED	---
SHL	EARTH GND.	PIN H

CONTROLLER PORT 1 CONNECTOR			
PIN	SIGNAL	TO	FUNCTION
1	TWISTED PAIR 1+	SDLC-1	CONT TXD+
2	LOGIC GND.	---	---
3	TWISTED PAIR 2+	SDLC-4	CONT TXC+
4	LOGIC GND.	---	---
5	TWISTED PAIR 3+	SDLC-7	CONT RXD+
6	LOGIC GND.	---	---
7	TWISTED PAIR 4+	SDLC-10	CONT RXC+
8	LOGIC GND.	---	---
9	TWISTED PAIR 1-	SDLC-2	CONT TXD-
10	PORT 1 DISABLE	---	---
11	TWISTED PAIR 2-	SDLC-5	CONT TXC-
12	EARTH GND.	SHIELD WIRE	---
13	TWISTED PAIR 3-	SDLC-8	CONT RXD-
14	RESERVED	---	---
15	TWISTED PAIR 4-	SDLC-11	CONT RXC-

MMU & BIU PORT 1 CONNECTOR			
PIN	SIGNAL	TO	FUNCTION
1	TWISTED PAIR 1+	SDLC-1	BIU RXD+
2	LOGIC GND.	---	---
3	TWISTED PAIR 2+	SDLC-4	BIU RXC+
4	LOGIC GND.	---	---
5	TWISTED PAIR 3+	SDLC-7	BIU TXD+
6	LOGIC GND.	---	---
7	TWISTED PAIR 4+	SDLC-10	BIU TXC+
8	LOGIC GND.	---	---
9	TWISTED PAIR 1-	SDLC-2	BIU RXD-
10	PORT 1 DISABLE	---	---
11	TWISTED PAIR 2-	SDLC-5	BIU RXC-
12	EARTH GND.	SHIELD WIRE	---
13	TWISTED PAIR 3-	SDLC-8	BIU TXD-
14	RESERVED	---	---
15	TWISTED PAIR 4-	SDLC-11	BIU TXC-

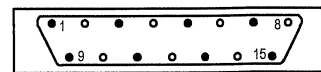

FRONT VIEW OF BU1 - BU5

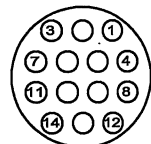

FRONT VIEW OF J1-J6

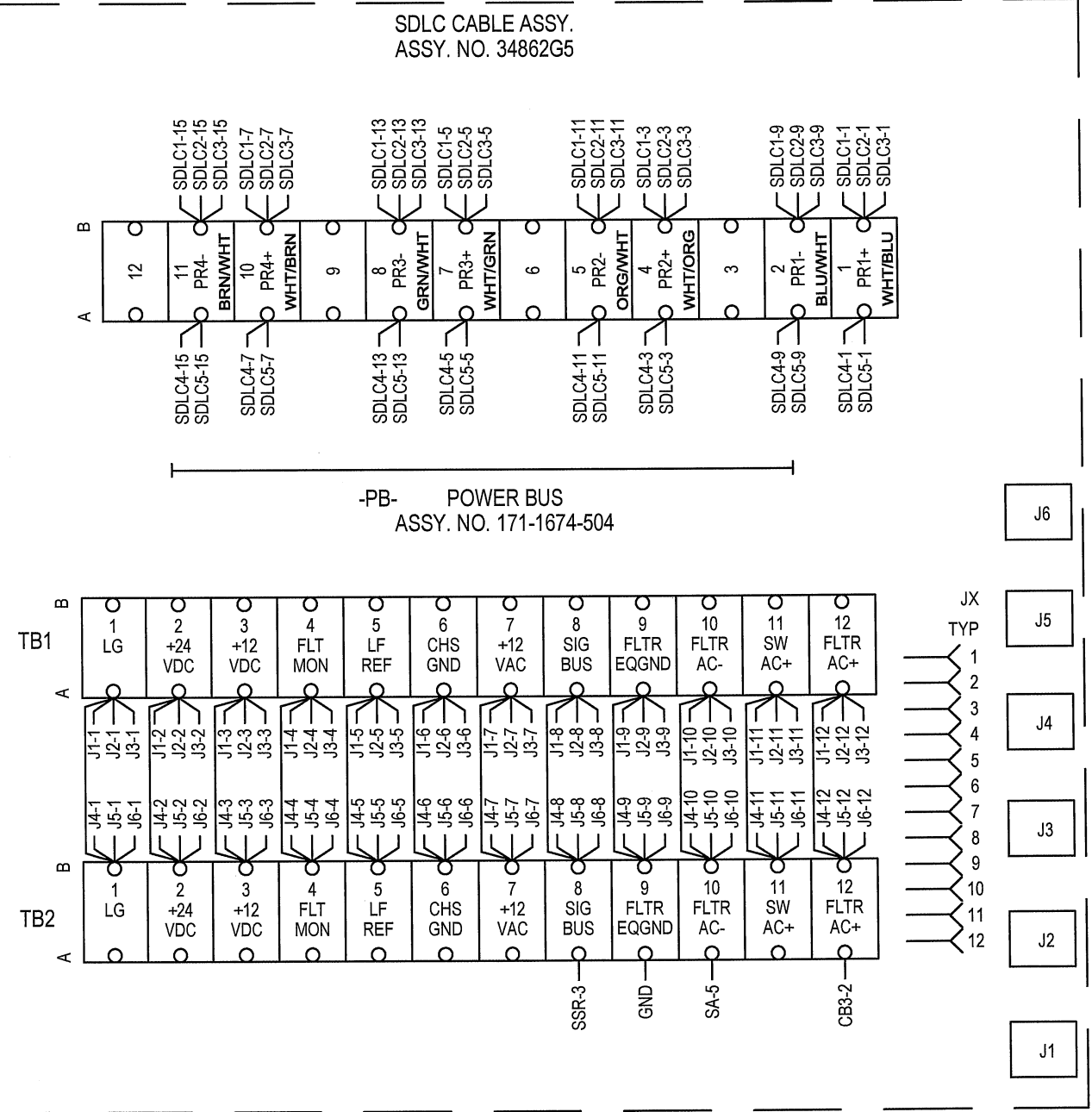

BIU AND CONNECTING CABLES

WIRE LIST FOR NEMA MALFUNCTION MANAGEMENT UNIT

CONNECTOR "A" (MMA)					CONNECTOR "B" (MMB)				
PIN	WIRE	MON. FUNCTION	TO	SIG. FUNCTION	PIN	WIRE	MON. FUNCTION	TO	SIG. FUNCTION
A	A-1	AC+ I INPUT	B21		A	B-1	AC+ II INPUT	J3-A2	MMU POWER
B	A-2	OUT RLY 1 OPEN	B22		B	B-2	S. DLY RLY COMM.	J3-A6	MMU POWER
C	A-3	OUT RLY 2 CLSD	B23		C	B-3	S. DLY RLY OPEN	B28	
D	A-4	CH. 12 GREEN	12G-A	^8 WLK	D	B-4	CH. 12 RED	B40	
E	A-5	CH. 11 GREEN	11G-A	^6 WLK	E	B-5	CH. 11 RED	B39	
F	A-6	CH. 10 GREEN	10G-A	^4 WLK	F	B-6	CH. 9 RED	B37	
G	A-7	CH. 9 GREEN	9G-A	^2 WLK	G	B-7	CH. 8 RED	8R-A	^8 RED
H	A-8	CH. 8 GREEN	8G-A	^8 GRN	H	B-8	CH. 7 RED	7R-A	^7 RED
J	A-9	CH. 7 GREEN	7G-A	^7 GRN	J	B-9	CH. 6 RED	6R-A	^6 RED
K	A-10	CH. 6 GREEN	6G-A	^6 GRN	K	B-10	CH. 5 RED	5R-A	^5 RED
L	A-11	CH. 5 GREEN	5G-A	^5 GRN	L	B-11	CH. 4 RED	4R-A	^4 RED
M	A-12	CH. 4 GREEN	4G-A	^4 GRN	M	B-12	CH. 2 RED	2R-A	^2 RED
N	A-13	CH. 3 GREEN	3G-A	^3 GRN	N	B-13	CH. 1 RED	1R-A	^1 RED
P	A-14	CH. 2 GREEN	2G-A	^2 GRN	P	B-14	(SPARE 1)	B29	
R	A-15	CH. 1 GREEN	1G-A	^1 GRN	R	B-15	+24V MONITOR II	B-3	+24V MON. II
S	A-16	+24V MON. I	B-4	LS +24V MON.	S	B-16	(SPARE 2)	B30	
T	A-17	LOGIC GND	B-14	LOGIC GND	T	B-17	CH. 13 RED	13R-A	OLA RED
U	A-18	CHASSIS GND	LS7-2	EARTH GND.	U	B-18	S. DLY RLY CLSD	J3-D5	CONT. POWER
V	A-19	AC- (COMMON)	K1-2	AC NEUTRAL	V	B-19	CH. 10 RED	B38	
W	A-20	OUT RLY 1 COM.	J3-A7	SIG BUS CONT	W	B-20	CH. 14 RED	14R-A	OLB RED
X	A-21	OUT RLY 2 COM.	A-27	LOGIC GND	X	B-21	CH. 15 RED	15R-A	OLC RED
Y	A-22	CH. 12 YELLOW	12Y-A	-T-	Y	B-22	CH. 16 RED	16R-A	OLD RED
Z	A-23	CH. 11 YELLOW	11Y-A	-T-	Z	B-23	CH. 3 RED	3R-A	^3 RED
a	A-24	CH. 10 WALK	----		a	B-24	RED ENABLE	LS8-1	SIG BUS CON.
b	A-25	CH. 10 YELLOW	10Y-A	-T-	b	B-25	(SPARE 3)	B31	
c	A-26	CH. 9 YELLOW	9Y-A	-T-	c	B-26	LOCAL FLASH IN	A32	POL/AX FLSH
d	A-27	CH. 8 YELLOW	8Y-A	^8 YEL		B-27	SHELL GROUND	LS6-2	EARTH GND.
e	A-28	CH. 7 YELLOW	7Y-A	^7 YEL					
f	A-29	CH. 6 YELLOW	6Y-A	^6 YEL					
g	A-30	CH. 5 YELLOW	5Y-A	^5 YEL					
h	A-31	CH. 3 YELLOW	3Y-A	^3 YEL					
i	A-32	CH. 15 GREEN	15G-A	OLC GRN					
j	A-33	CH. 2 YELLOW	2Y-A	^2 YEL					
k	A-34	CH. 1 YELLOW	1Y-A	^1 YEL					
m	A-35	CONT. VOLT. MON.	B-5	VOLT. MON.					
n	A-36	+24V MON. INH.	B-2						
p	A-37	OUT RLY 1 CLSD	J3-A3						
q	A-38	OUT RLY 2 OPEN	A-31	STOP TIME					
r	A-39	CH. 12 WALK	----						
s	A-40	CH. 11 WALK	----						
t	A-41	CH. 9 WALK	----						
u	A-42	CH. 16 YELLOW	16Y-A	OLD YEL					
v	A-43	CH. 15 YELLOW	15Y-A	OLC YEL					
w	A-44	CH. 13 YELLOW	13Y-A	OLA YEL					
x	A-45	CH. 4 YELLOW	4Y-A	^4 YEL					
y	A-46	CH. 14 GREEN	14G-A	OLB GRN					
z	A-47	CH. 13 GREEN	13G-A	OLA GRN					
AA	A-48	(SPARE 1)	B24						
BB	A-49	RESET	B-1						
CC	A-50	CAB. INTLK A	B25						
DD	A-51	CAB. INTLK B	B26						
EE	A-52	CH. 14 YELLOW	14Y-A	OLB YEL					
FF	A-53	CH. 16 GREEN	16G-A	OLD GRN					
GG	A-54	(SPARE 2)	B27						
HH	A-55	TYPE SELECT	A-20	MMU/CMU SEL.					
	A-56	SHELL GND	LS15-2	EARTH GND.					

NOTES FOR 16 CHANNEL M.M.U.

- (1) RELAY CONTACT POSITIONS SPECIFIED ARE FOR NON-CONFLICT MODE.
- (2) TO PROGRAM MMU, SOLDER JUMPERS IN PROGRAMMING CARD FOR ALL PERMISSABLE PHASE MOVEMENTS, MINIMUM CHANGE DISABLE FOR ALL PEDESTRIAN CHANNELS, AND MIN. FLASH, VOLTAGE MON., AND 24V. MON. LATCH OPTIONS AS DESIRED.

M.M.U. CHANNEL ASSIGNMENTS

CH. 1 =	L/S 1 =	^1 VEH.
CH. 2 =	L/S 2 =	^2 VEH.
CH. 3 =	L/S 3 =	^3 VEH.
CH. 4 =	L/S 4 =	^4 VEH.
CH. 5 =	L/S 5 =	^5 VEH.
CH. 6 =	L/S 6 =	^6 VEH.
CH. 7 =	L/S 7 =	^7 VEH.
CH. 8 =	L/S 8 =	^8 VEH.
CH. 9 =	L/S 9 =	^2 PED.
CH. 10 =	L/S 10 =	^4 PED.
CH. 11 =	L/S 11 =	^6 PED.
CH. 12 =	L/S 12 =	^8 PED.
CH. 13 =	L/S 13 =	O'LAP A VEH.
CH. 14 =	L/S 14 =	O'LAP B VEH.
CH. 15 =	L/S 15 =	O'LAP C VEH.
CH. 16 =	L/S 16 =	O'LAP D VEH.

MMU PROGRAM CARD

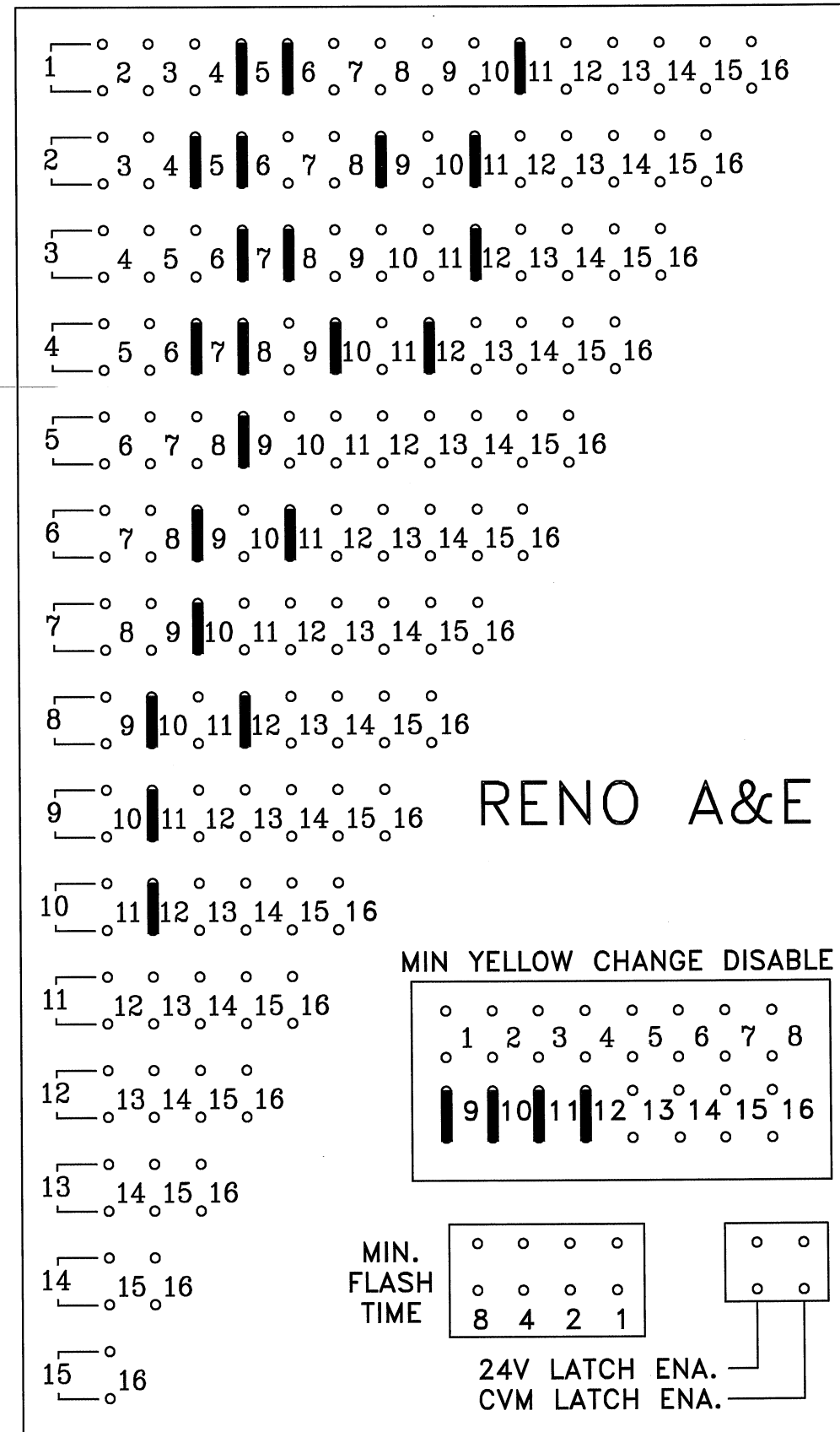

RENO A&E

M.M.U. C/C'S AND PROGRAM CARD

DETECTOR RACK 34030G1 #1

B.I.U.	L3	L1	L7	L5	L11	L9	L15	L13	PMT 5	PMT 3	PGM. CARD	
	5-1	1-1	2-3	2-1	6-3	6-1			<input type="checkbox"/> 2CH OPTICOM CH. C CH. D	<input type="checkbox"/> 2CH OPTICOM CH. A CH. B		NOT USED
	<input type="checkbox"/> 2CH	<input type="checkbox"/> 2CH	<input type="checkbox"/> 2CH	<input type="checkbox"/> 2CH	<input type="checkbox"/> 2CH	<input type="checkbox"/> 2CH	<input type="checkbox"/> 2CH	<input type="checkbox"/> 2CH				
5-2	1-2	2-4	2-2	6-4	6-2							
ADDRESS BIT JUMPERS JP37 JP36 JP35 0 0 0 (ADDRESS 1)	L4	L2	L8	L6	L12	L10	L16	L14	PMT 6	PMT 4		

<input checked="" type="checkbox"/> J13 171-1083-515 DC POWER	<input checked="" type="checkbox"/> J16 C/C 33284G8 EXP. OUTPUTS	<input checked="" type="checkbox"/> J14 C/C 33284G2 LPS 1-8	<input type="checkbox"/> J18 C/C 33284G9 SYS. OUTPUTS	<input checked="" type="checkbox"/> J15 C/C 33284G3 LPS 9-16	<input checked="" type="checkbox"/> J17 171-1083-515 AC POWER	<input type="checkbox"/> J19 C/C 33284G17 PGM. CARD
---	--	---	---	--	---	---

DETECTOR RACK 34030G1 #2

B.I.U.	L3	L1	L7	L5	L11	L9	L15	L13			PGM. CARD	
	7-1	3-1	4-3	4-1	8-3	8-1						NOT USED
	<input type="checkbox"/> 2CH	<input type="checkbox"/> 2CH	<input type="checkbox"/> 2CH	<input type="checkbox"/> 2CH	<input type="checkbox"/> 2CH	<input type="checkbox"/> 2CH	<input type="checkbox"/> 2CH	<input type="checkbox"/> 2CH				
7-2	3-2		4-2	8-4	8-2							
ADDRESS BIT JUMPERS JP37 JP36 JP35 0 0 0 (ADDRESS 2)	L4	L2	L8	L6	L12	L10	L16	L14				

<input checked="" type="checkbox"/> J13 171-1083-515 DC POWER	<input type="checkbox"/> J16 C/C 33284G8 EXP. OUTPUTS	<input checked="" type="checkbox"/> J14 C/C 33284G2 LPS 1-8	<input type="checkbox"/> J18 C/C 33284G9 SYS. OUTPUTS	<input checked="" type="checkbox"/> J15 C/C 33284G3 LPS 9-16	<input checked="" type="checkbox"/> J17 171-1083-515 AC POWER	<input type="checkbox"/> J19 C/C 33284G17 PGM. CARD
---	---	---	---	--	---	---

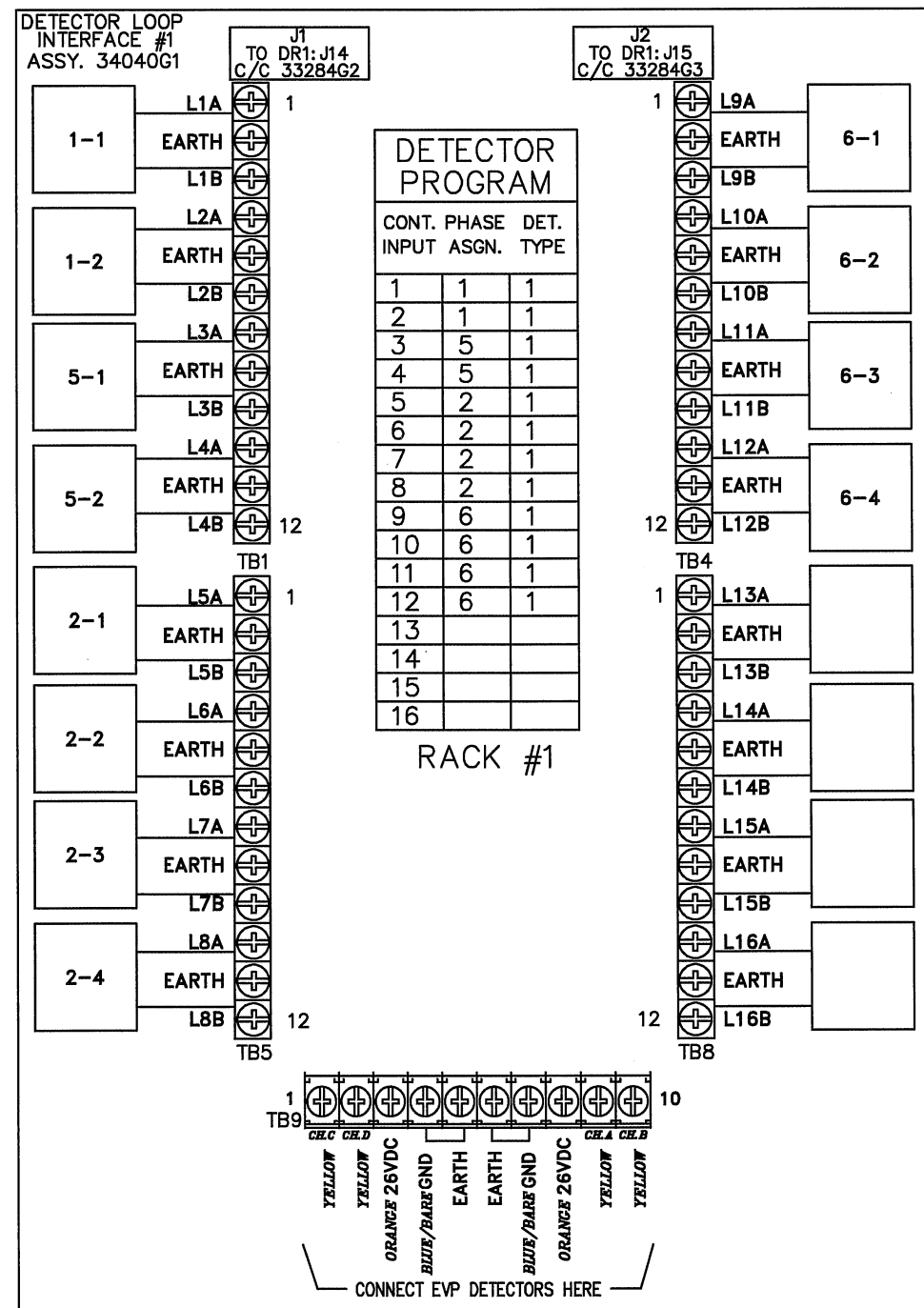

RACK 1 AND 2

DET. LOOPS 1-8 (J14)	C/C 33284G2
PIN	SIGNAL TO
1	LOOP 1+ LPI1: TB1-1
2	LOOP 1- LPI1: TB1-3
3	LOOP 2+ LPI1: TB1-4
4	LOOP 2- LPI1: TB1-6
5	LOOP 3+ LPI1: TB1-7
6	LOOP 3- LPI1: TB1-9
7	LOOP 4+ LPI1: TB1-10
8	LOOP 4- LPI1: TB1-12
9	LOOP 5+ LPI1: TB5-1
10	LOOP 5- LPI1: TB5-3
11	LOOP 6+ LPI1: TB5-4
12	LOOP 6- LPI1: TB5-6
13	LOOP 7+ LPI1: TB5-7
14	LOOP 7- LPI1: TB5-9
15	LOOP 8+ LPI1: TB5-10
16	LOOP 8- LPI1: TB5-12
17	PMT. DET. CH. C LPI1: TB9-1
18	PMT. DET. CH. D LPI1: TB9-2
19	KEY PIN
20	PMT. CH. C/D +26VDC LPI1: TB9-3
21	PMT. DC GROUND LPI1: TB9-4,7
22	PMT. CH. A/B +26VDC LPI1: TB9-8
23	PMT. DET. CH. A LPI1: TB9-9
24	PMT. DET. CH. B LPI1: TB9-10
25	----
26	----

RACK 1 AND 2

DET. LOOPS 9-16 (J15)	C/C 33284G3
PIN	SIGNAL TO
1	LOOP 9+ LPI2: TB4-1
2	LOOP 9- LPI2: TB4-3
3	LOOP 10+ LPI2: TB4-4
4	LOOP 10- LPI2: TB4-6
5	LOOP 11+ LPI2: TB4-7
6	LOOP 11- LPI2: TB4-9
7	LOOP 12+ LPI2: TB4-10
8	LOOP 12- LPI2: TB4-12
9	LOOP 13+ LPI2: TB8-1
10	LOOP 13- LPI2: TB8-3
11	LOOP 14+ LPI2: TB8-4
12	LOOP 14- LPI2: TB8-6
13	LOOP 15+ LPI2: TB8-7
14	LOOP 15- LPI2: TB8-9
15	LOOP 16+ LPI2: TB8-10
16	LOOP 16- LPI2: TB8-12
17	----
18	----
19	----
20	----

RACK 1 ONLY

EXPANSION OUTPUTS C/C 33284G4		
J16	FUNCTION	TO
17	EVP 5 CALL	MP: B19
18	EVP 6 CALL	MP: B20
19	EVP 3 CALL	MP: B17
20	EVP 4 CALL	MP: B18

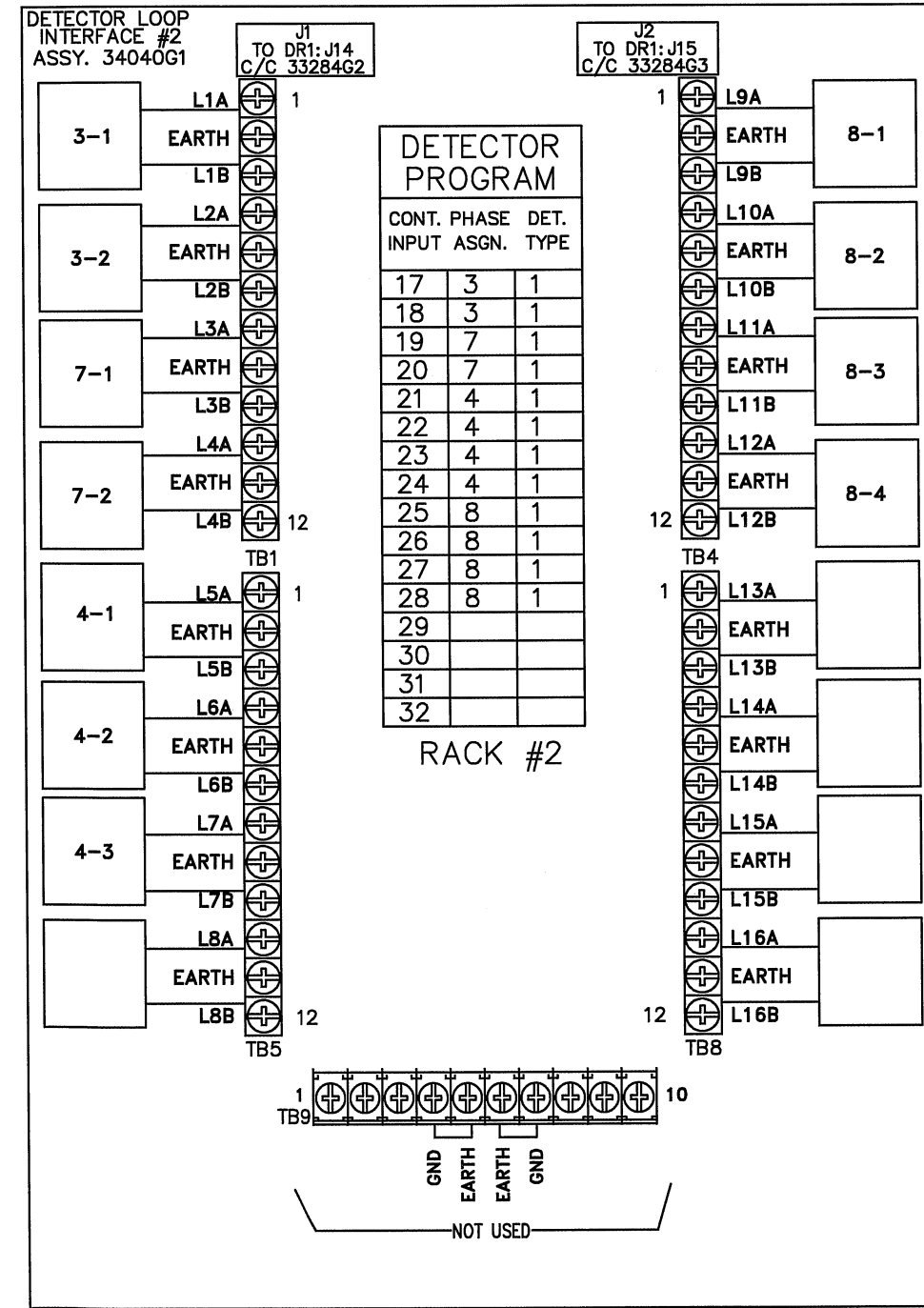

RACK 1 AND 2

DET. RACK POWER 171-1083-515			
P1/ DR: J13	P2/ DR: J17	FUNCTION	TO
1		+12 VDC (DET. POWER)	PB-3
2		+24 VDC (BIU POWER)	PB-2
3		LOGIC GROUND	PB-1
4		EARTH GROUND	PB-9
5		"KEY PIN"	
6		LINE FREQUENCY REF.	PB-5
	1	EARTH GROUND	----
	2	AC LINE	PB-12
	3	AC NEUTRAL	PB-10
	4	LOGIC GROUND	----

#116 AT QUINN ST

B.I.U	DET	PH	F	DET	DLY	EXT	DET	PH	F	DET	DLY	EXT	DET	PH	F	DET	DLY	EXT	DET	PH	F	DET	DLY	EXT	EVP	PH	POLE #	CONT CH #
	CH 1	1	1	1-1			CH 5	2	1	2-1			CH 9	6	1	6-1			CH 13						CH 1	1-6	4	3
	CH 2	1	1	1-2			CH 6	2	1	2-2			CH 10	6	1	6-2			CH 14						CH 2	2-5	2	4
	CH 3	5	1	5-1			CH 7	2	1	2-3			CH 11	6	1	6-3			CH 15						CH 3	3-8	1	5
	CH 4	5	1	5-2			CH 8	2	1	2-4			CH 12	6	1	6-4			CH 16						CH 4	4-7	3	6

B.I.U	DET	PH	F	DET	DLY	EXT	DET	PH	F	DET	DLY	EXT	DET	PH	F	DET	DLY	EXT	DET	PH	F	DET	DLY	EXT				
	CH 17	3	1	3-1			CH 21	4	1	4-1			CH 25	8	1	8-1			CH 29									
	CH 18	3	7	3-2			CH 22	4	1	4-2	5.0		CH 26	8	1	8-2			CH 30									
	CH 19	7	1	7-1			CH 23	4	1	4-3	5.0		CH 27	8	1	8-3	10.0		CH 31									
	CH 20	7	7	7-2			CH 24						CH 28	8	1	8-4			CH 32									

EVP SENSORS

CABLE	DISCR. CHAN.	PHASES	POLE#	TERMINAL TB9		
				SIGNAL	DC(+)	GND
55	1	1-6	4	A	26+	GND
28	2	2-5	2	B	26+	GND
18	3	3-8	1	C	26+	GND
63	4	4-7	3	D	26+	GND

VEHICLE SIGNALS

CABLE	SIGNAL	TERMINAL						
		G	FLA	Y	R	G	Y	R
46	1-1	1	3	5	7			
56	1-2	2	4	6	8			
22,24	2-1,2-3					9	11	13
23	2-2					10	12	14
10	3-1	15	17	19	21			
47	3-2	16	18	20	22			
59	4-1					23	25	27
60	4-2					24	26	28
19	5-1	29	31	33	35			
11	5-2	30	32	34	36			
49,51	6-1,6-3					37	39	41
50	6-2					38	40	42
57	7-1	43	45	47	49			
20	7-2	44	46	48	50			
13	8-1					51	53	55
14	8-2					52	54	56

VEH DETECTORS

CABLE	DET	SLOT	FUNC	RACK	TERMINAL
38	1-1	1	1	1	L1
39	1-2	2	1	1	L2
79	2-1	5	1	1	L5
80	2-2	6	1	1	L6
78	2-3	7	1	1	L7
75	2-4	8	1	1	L8
43	3-1	17	1	2	L1
44	3-2	18	1	2	L2
70	4-1	21	1	2	L5
72	4-2	22	7	2	L6
71	4-3	23	7	2	L7
76	5-1	3	1	1	L3
77	5-2	4	1	1	L4
35	6-1	9	1	1	L9
36	6-2	10	1	1	L10
34	6-3	11	1	1	L11
37	6-4	12	1	1	L12
73	7-1	19	1	2	L3
74	7-2	20	7	2	L4
45	8-1	25	1	2	L9
40	8-2	26	1	2	L10
41	8-3	27	7	2	L11
42	8-4	28	1	2	L12

PED PUSHBUTTONS

CABLE	PPB	TERMINAL	RETURN
69	2-1	1	2
33	2-2	1	2
67	4-1	1	2
68	4-2	1	2
30	6-1	1	2
66	6-2	1	2
32	8-1	1	2
31	8-2	1	2

PED SIGNALS

CABLE	SIGNAL	TERMINAL	
		WK	DW
61	2-1	57	61
25	2-2	58	62
52	4-1	63	67
62	4-2	64	68
15	6-1	69	73
63	6-2	70	74
28	8-1	75	79
16	8-2	76	80

EVP VERIFY LIGHTS

CABLE	CONTR CHAN.	PHASES	POLE#	TERM.
27	4	2-5	2	65
17	5	3-8	1	71
63	6	4-7	3	77