

ASC/2S-2100 CONTROLLER WITH:

- CONFIGURATION EEPROM 32790C1440
- SOFTWARE: V1.72
- SPECIAL SOFTWARE: SEE BELOW FUNCTION
- OVERLAPS
 - IN EEPROM
 - KEYBOARD ENTERED
- ANALOG TELEMETRY MODULE: 32825G1
- F/O TELEMETRY MODULE: 33525G1
- TEST INPUT A =
- TEST INPUT B =

A =
B =
C =
D =

LEGEND

BIU	BUS INTERFACE UNIT
BU()	C/C, BIU ()
CB()	CIRCUIT BREAKER ()
C/C	CONNECTING CABLE
CCA	CONTROLLER CABLE "A"
CDP	C/C, DR POWER
CMA	MMU/CMU CABLE "A"
CMB	MMU/CMU CABLE "B"
CPO	C/C PRE-EMPT OUTPUTS
CPP	C/C PRE-EMPT POWER
DR	DETECTOR RACK
DS()	DOOR SWITCH ()
FL()	FLASHER ()
FR()	FLASH XFER. RELAY
LS()	LOAD SWITCH
MC	MERCURY CONTACTOR
MP	MAIN PANEL
PAP	POWER-AUX PANEL
PSP	CAB. PWR. SUPPLY
SA	SURGE ARRESTOR
TB-()	TERM. BLOCK ()

MAIN PANEL PLUG-IN REQUIREMENTS

BIU2 T&F	BIU3 T&F	LS9 PED 2 BEACONS	LS10 PED 4 BEACONS	LS11 PED 6 BEACONS	LS12 PED 8 BEACONS	LS13 OL "A"	LS14 OL "B"	LS15 OL "C"	LS16 OL "D"
BIU1 T&F	LS1 VEH 1	LS2 VEH 2	LS3 VEH 3	LS4 VEH 4	LS5 VEH 5	LS6 VEH 6	LS7 VEH 7	LS8 VEH 8	FL1 □ 1CKT ■ 2CKT
FR1 L R V1 V5	FR2 L R V2 V6	✕FR3 L R V3 V7	FR4 L R V4 V8	✕FR5 L R A C	✕FR6 L R B D	K1 LS 24V CONT.			

■ DENOTES TYPE OF OPERATION AND/OR WHERE PLUG-IN IS REQUIRED. L = LEFT, R = RIGHT.
 ✕ DENOTES WHERE "UNUSED RED" JUMPER PART NUMBER 32448G1 IS REQUIRED. INSTALL BETWEEN PINS 1 & 3 FOR LOAD SWITCH OR PINS 6 & 8 AND 5 & 7 FOR FLASH TRANSFER RELAY.

FLASH:
 □ ø2&6 YELLOW, ALL OTHERS RED.
 ■ ALL RED.
 ■ RELAYS DE-ENERGIZED FOR FLASH.
 □ RELAYS ENERGIZED FOR FLASH.

FLASHER	
PIN	FUNCTION
7	CIRCUIT #1
8	CIRCUIT #2
9	CHASSIS GND
10	AC COMMON
11	115 VAC
12	-----

LOAD SWITCH	
PIN	FUNCTION
1	115 VAC
2	CHASSIS GND
3	RED/DW OUTPUT
4	-----
5	YEL OUTPUT
6	RED/DW INPUT
7	GRN/W OUTPUT
8	YEL INPUT
9	+24 VDC
10	GRN/W INPUT
11	AC COMMON
12	-----

① 2.2K
10W

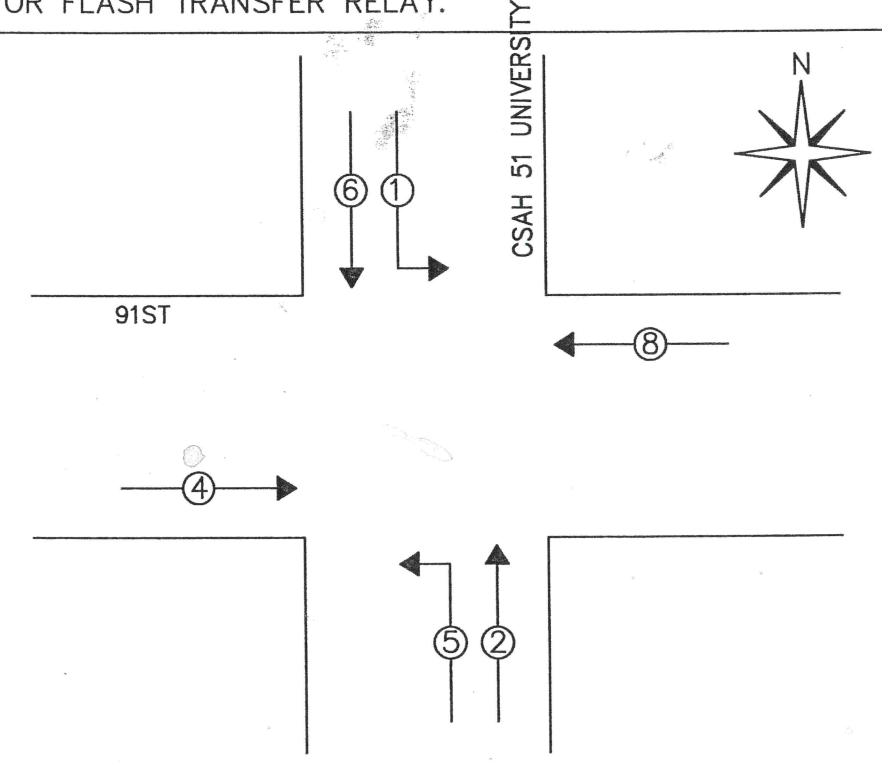

SHEET 1 OF 11

3 USE ONLY COPPER CONDUCTORS FOR FIELD AND SERVICE CONNECTIONS.
 2 CONNECT A.C. SERVICE TO TERMINAL BLOCK 501 (LINE), 502 (NEUTRAL) AND GB2 (EARTH) ON RIGHT SIDEWALL OF CABINET.
 ① INSTALL 2.2K, 10 WATT LOAD RESISTORS BETWEEN PINS 7 AND 11 ON LOAD SWITCHES 9, 10, 11 & 12.
 NOTES: UNLESS SPECIFIED OTHERWISE

DESIGNER G.V. T.C.C.	DATE 02/03/97	ECONOLITE CONTROL PRODUCTS INC.	TRAFFIC CONTROL CORPORATION	5653 MEMORIAL AVE. OAK PARK HTS, MN 55082
DRAWN MA TCC	6/9/04			CABINET SPECIFICATION: TS2TYPE1 2004 ANOKA COUNTY
CABINET SIZE		CUSTOMER: ANOKA COUNTY HIGHWAY DEPARTMENT		FLASHER
INSPECTED		INTERSECTION: #51 AT 91ST		SW.PACKS
APPROVED		LOCATION:		
CUSTOMER P.O.	INSTALLED BY	SYSTEM:	SALES ORDER NO.	SIZE B
				DRAWING #TS20216PG INTERC

AUXILLARY SWITCH PANEL

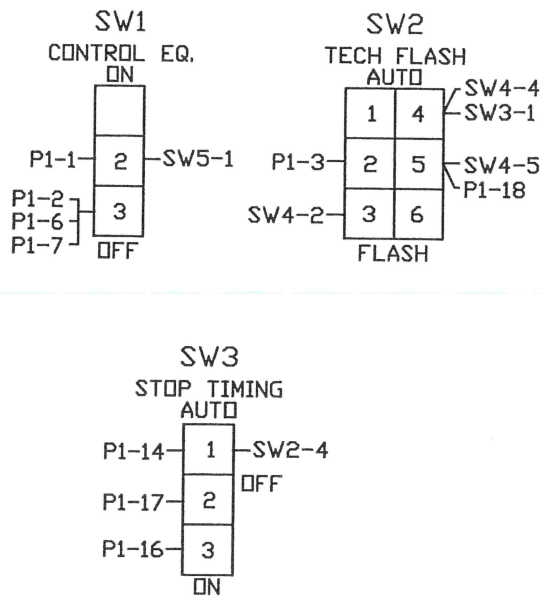

POLICE SWITCH PANEL

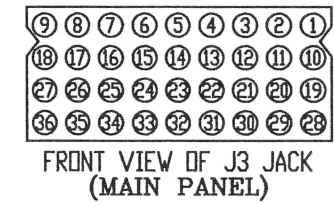
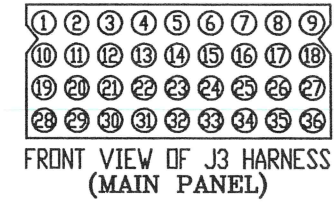
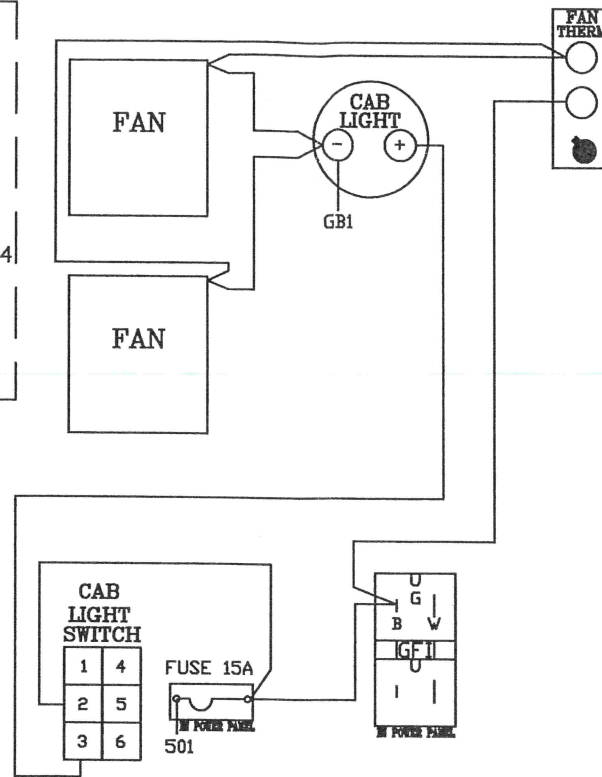
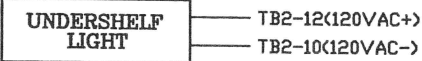
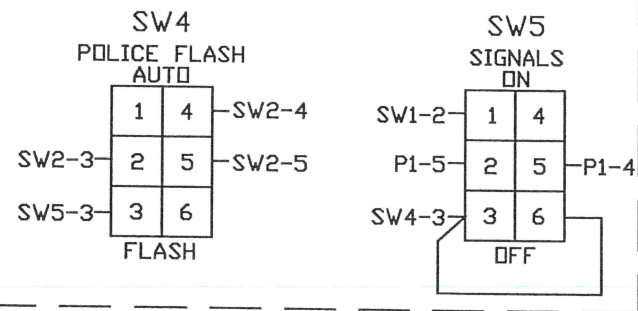

FRONT VIEW OF J1 HARNESS (SWITCH PANEL)



FRONT VIEW OF J1 JACK (SWITCH PANEL)

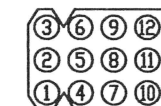

FRONT VIEW OF J1-J6 HARNESSES (POWER BUS PANEL)



FRONT VIEW OF J1-J6 JACKS (POWER BUS PANEL)

POWER/AUX PANEL (PAP) 34830G5

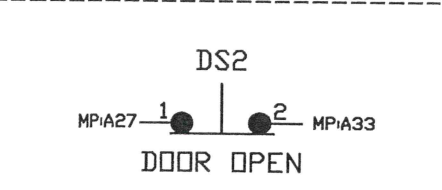
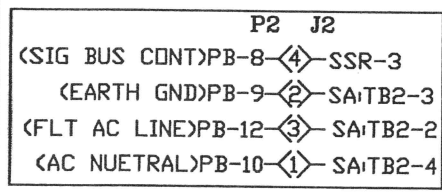
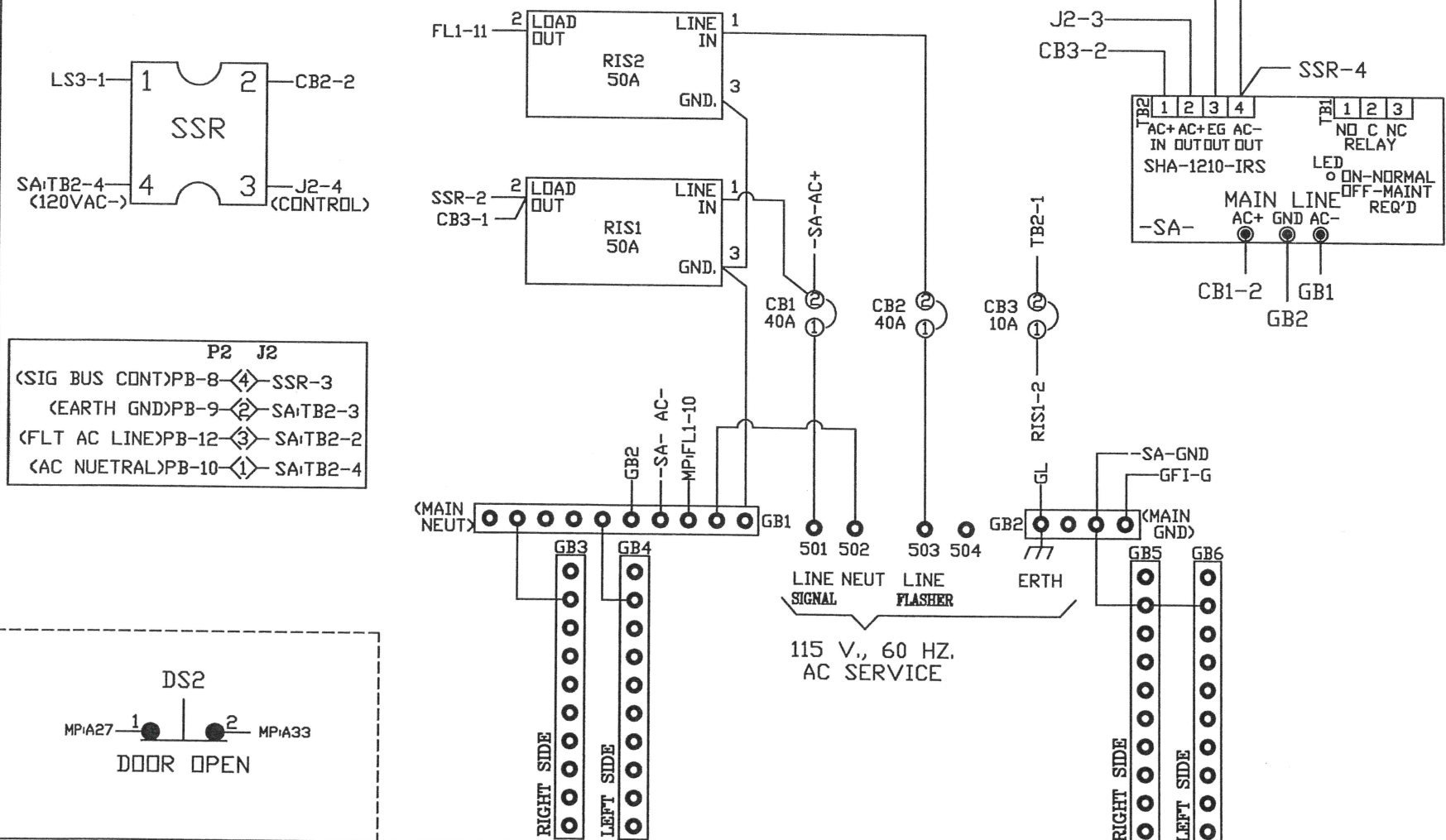

J3	P1
J3-36	P1-1
MMB-1	P1-2
MMA-37	P1-3
K1-10	P1-4
FR6-2	P1-5
MMB-2	P1-6
MMA-20	P1-7
	P1-8
	P1-9
	P1-10
	P1-11
	P1-12
A-39	P1-13
A-35	P1-14
A-40	P1-15
A-31	P1-16
A-30	P1-17
A-32	P1-18
A-38	P1-19
A-33	P1-20
A-34	P1-21
K1-9	P1-22
B-3	P1-23
B-4	P1-24

J3	J1
A-35	J1-1
K1-11	J1-2
	J1-3
B-5	J1-4
J1-31B	J1-5
	J1-6
J1-27B	J1-7
K1-10	J1-8
	J1-9
K1-2	J1-10
MMB-18	J1-11
J3-1	J1-12

CONFIRMATION BEACONS

EVP 3 = 1-6
 EVP 4 = 2-5
 EVP 5 = 8
 EVP 6 = 4

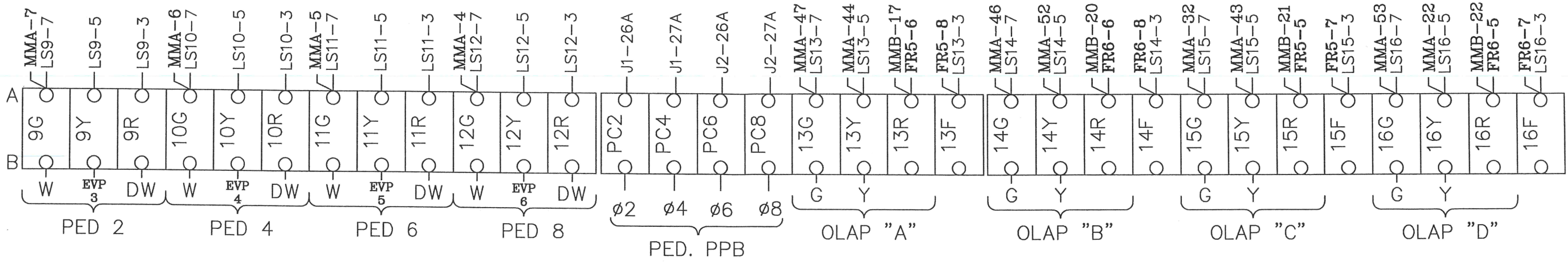

(P.B. COMMON TO GB1)

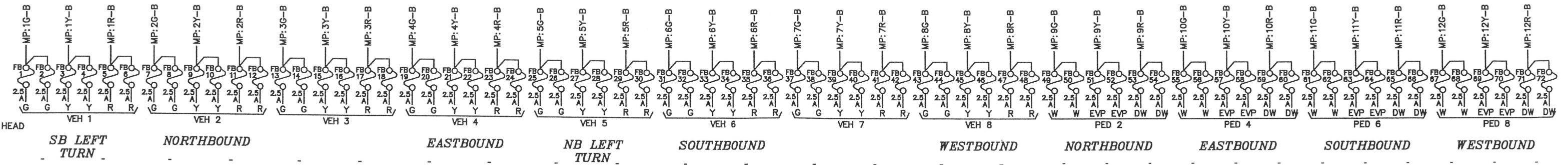
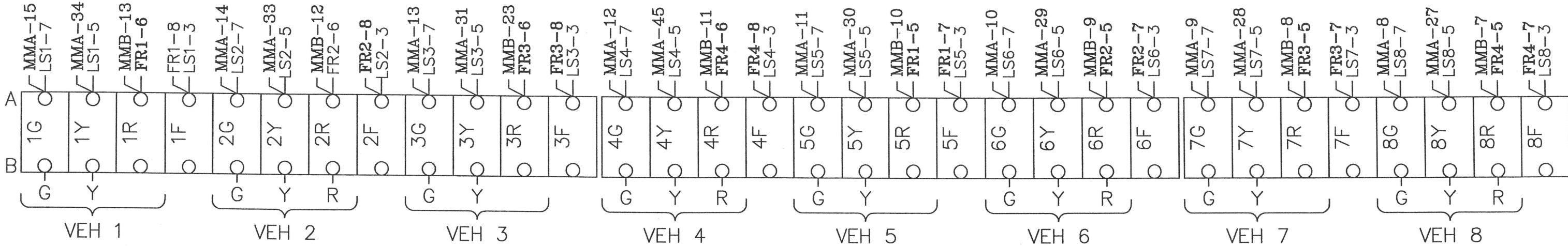

①
2.2K
10W

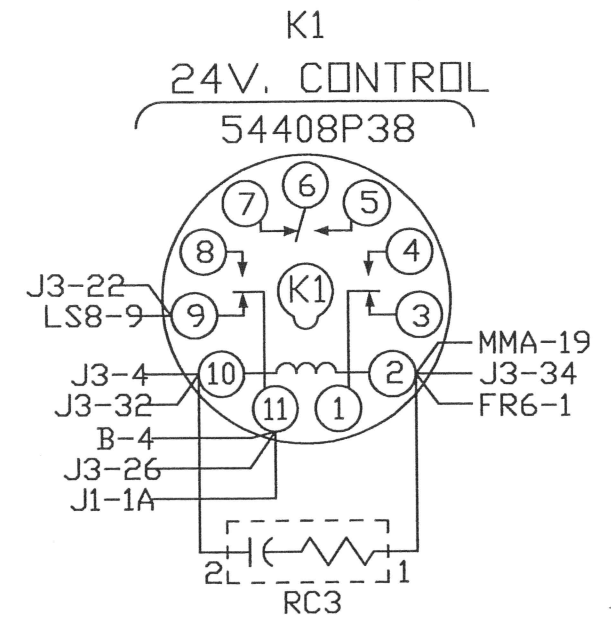
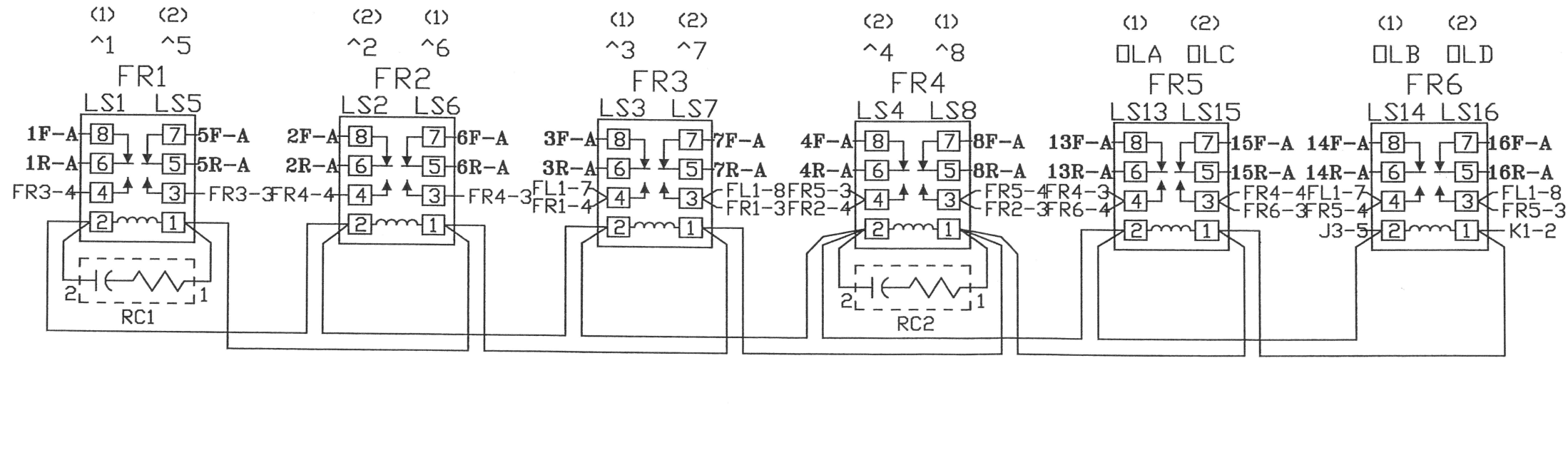
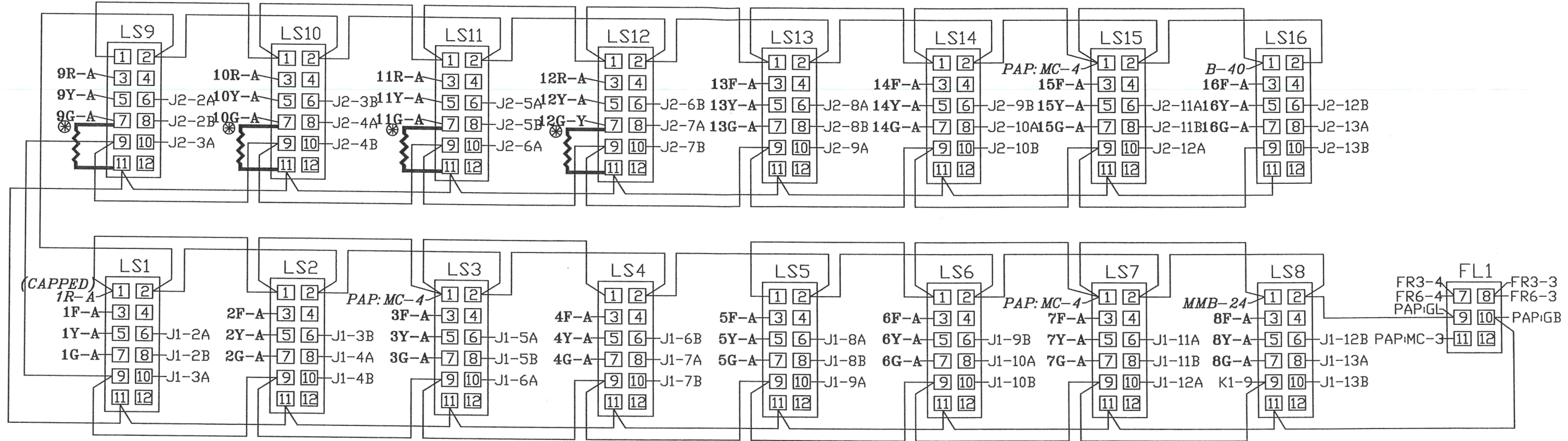

LOADBAY AND FLASH RELAY'S

1	M.M.U. RESET	MMA-49	J2-21B	RG. 1 INHBT. MAX.
2	24 V. MON. INHBT.	MMA-36	J2-22A	RG. 2 INHBT. MAX.
3	M.M.U. +24 V. MON. 2	J3-23	J1-23B	RG. 1 FORCE OFF
4	M.M.U. +24 V. MON. 1	MMB-15	J1-24A	RG. 2 FORCE OFF
5	FAULT MON.	K1-11	J1-22B	RG. 1 MAX. 2 SEL.
6	PC1 PED. DET. 1	J3-24	J1-23A	RG. 2 MAX. 2 SEL.
7	PC3 PED. DET. 3	MMA-16	J1-24B	CALL NON-AC 1
8	PC5 PED. DET. 5	J3-28	J2-19A	CALL NON-AC 2
9	PC7 PED. DET. 7	MMA-35	J1-25A	WALK REST MDFR.
10	B.I.U. SPR. 1	J1-25B	J1-20A	EXT. MIN. RECALL
11	B.I.U. SPR. 2	J1-26B	J1-20B	EXT. START
12	B.I.U. SPR. 3	J1-20A	J1-17A	TEST INPUT A
13	B.I.U. SPR. 4	J2-20B	J1-17B	TEST INPUT B
14	LOGIC GND.	J2-21A	J2-25A	TEST INPUT C
15	PMT. CALL 1	MMA-17	J2-25A	T.B.C. ON LINE
16	PMT. CALL 2	J1-32A	J1-21A	T.B.C. AUX. 1
17	PMT. CALL 3	A-20	J1-14A	T.B.C. AUX. 2
18	PMT. CALL 4	J1-16A	J1-14A	T.B.C. AUX. 3
19	PMT. CALL 5	J1-16B	J1-14B	COORD. STATUS OUT
20	PMT. CALL 6	J2-17A	J2-14A	LOGIC GND.
		J2-17B	J2-14A	
		J2-18A	J2-14B	
		J2-18B	J2-14B	
		J2-18B	J2-14B	
		J2-18B	J2-14B	

J16-19
J16-20
J16-17
J16-18

21	MMA AC+ I IN	MMA-1	J1-15A	PMT. 1 ACTV.
22	DIR1 OPEN	MMA-2	J1-15B	PMT. 2 ACTV.
23	DIR2 OPEN	MMA-3	J2-15A	PMT. 3 ACTV.
24	CLSD MMA SPR 1	MMA-48	J2-15B	PMT. 4 ACTV.
25	CAB INTLK A	MMA-50	J2-16A	PMT. 5 ACTV.
26	CAB INTLK B	MMA-51	J2-16B	PMT. 6 ACTV.
27	MMA SPR 2	MMA-54	J2-16B	LOGIC GND
28	SDR OPEN	MMA-21	J2-16B	LOGIC GND
29	MMB SPR 1	MMA-54	J2-16B	LOGIC GND
30	MMB SPR 2	MMA-54	J2-16B	STOP TIMING 1 & 2
31	MMB SPR 3	MMA-54	J2-16B	MMU STOP TIMING
32		MMA-25	J2-23A	LOCAL FLASH STATUS
33		J2-22B	J2-23B	ALARM 1
34		J3-18	J3-20	ALARM 2
35		J2-23B	J2-24A	LOGIC GND
36		J3-20	J3-21	DIM. ENABLE
37	AC+	J1-18B	J1-18A	AUTO FLASH
38	AC+	J1-18A	J2-24B	COORD. FREE
39	AC+	J2-24B	J3-19	MANUAL CONT. ENABLE
40	AC+	J3-19	J1-19A	INTRVL. ADV.
		J3-13	J3-13	
		J1-19B	J1-19B	
		J3-15	J3-15	

INTERFACE TERMINAL BLOCKS

J1 BIU #1			J2 BIU #2		
PIN	FUNCTION	TO	PIN	FUNCTION	TO
1A	+24 VDC	K1-11	1A	+24 VDC	J2-1B
1B	+24 VDC	J2-1B	1B	+24 VDC	J1-1B
2A	LS1 RED	LS1-6	2A	LS9 RED	LS9-6
2B	LS1 YELLOW	LS1-8	2B	LS9 YELLOW	LS9-8
3A	LS1 GREEN	LS1-10	3A	LS9 GREEN	LS9-10
3B	LS2 RED	LS2-6	3B	LS10 RED	LS10-6
4A	LS2 YELLOW	LS2-8	4A	LS10 YELLOW	LS10-8
4B	LS2 GREEN	LS2-10	4B	LS10 GREEN	LS10-10
5A	LS3 RED	LS3-6	5A	LS11 RED	LS11-6
5B	LS3 YELLOW	LS3-8	5B	LS11 YELLOW	LS11-8
6A	LS3 GREEN	LS3-10	6A	LS11 GREEN	LS11-10
6B	LS4 RED	LS4-6	6B	LS12 RED	LS12-6
7A	LS4 YELLOW	LS4-8	7A	LS12 YELLOW	LS12-8
7B	LS4 GREEN	LS4-10	7B	LS12 GREEN	LS12-10
8A	LS5 RED	LS5-6	8A	LS13 RED	LS13-6
8B	LS5 YELLOW	LS5-8	8B	LS13 YELLOW	LS13-8
9A	LS5 GREEN	LS5-10	9A	LS13 GREEN	LS13-10
9B	LS6 RED	LS6-6	9B	LS14 RED	LS14-6
10A	LS6 YELLOW	LS6-8	10A	LS14 YELLOW	LS14-8
10B	LS6 GREEN	LS6-10	10B	LS14 GREEN	LS14-10
11A	LS7 RED	LS7-6	11A	LS15 RED	LS15-6
11B	LS7 YELLOW	LS7-8	11B	LS15 YELLOW	LS15-8
12A	LS7 GREEN	LS7-10	12A	LS15 GREEN	LS15-10
12B	LS8 RED	LS8-6	12B	LS16-RED	LS16-6
13A	LS8 YELLOW	LS8-8	13A	LS16-YELLOW	LS16-8
13B	LS8 GREEN	LS8-10	13B	LS16-GREEN	LS16-10
14A	TBC AUX 1	A-16	14A	TBC AUX 3	A-18
14B	TBC AUX 2	A-17	14B	COORD. STATUS	A-19
15A	PMT ACT 1	A-21	15A	PMT ACT 3	A-23
15B	PMT ACT 2	A-22	15B	PMT ACT 4	A-24
16A	PMT CALL 1	B-15	16A	PMT ACT 5	A-25
16B	PMT CALL 2	B-16	16B	PMT ACT 6	A-26
17A	TEST A	A-12	17A	PMT CALL 3	B-17
17B	TEST B	A-13	17B	PMT CALL 4	B-18
18A	AUTO FLASH	A-37	18A	PMT CALL 5	B-19
18B	DIM. ENABLE	A-36	18B	PMT CALL 6	B-20
19A	MANUAL CONT.	A-39	19A	CNA 2	A-8
19B	INT. ADVANCE	A-40	19B	SPARE 1	B-10
20A	EXT. MIN. RECALL	A-10	20A	SPARE 2	B-11
20B	EXT. START	A-11	20B	SPARE 3	B-12
21A	TBC ONLINE	A-15	21A	SPARE 4	B-13
21B	STOP TIME (1)	A-30	21B	INHIBIT MAX (1)	A-1
22A	STOP TIME (2)	A-30	22A	INHIBIT MAX (2)	A-2
22B	MAX. 2 (1)	A-5	22B	LOCAL FLASH	A-32
23A	MAX. 2 (2)	A-6	23A	MMU FLASH	A-31
23B	FORCE OFF (1)	A-3	23B	ALARM 1	A-33
24A	FORCE OFF (2)	A-4	24A	ALARM 2	A-34
24B	CNA 1	A-7	24B	COORD FREE IN	A-38
25A	WALK REST MOD.	A-9	25A	TEST C	A-14
25B	PED. ISD. 1	B-6	25B	PED. ISD. 5	B-8
26A	PED. ISD. 2	PC2-A	26A	PED. ISD. 6	PC6-A
26B	PED. ISD. 3	B-7	26B	PED. ISD. 7	B-9
27A	PED. ISD. 4	PC4-A	27A	PED. ISD. 8	PC8-A
27B	PED. ISD. COMN.	J3-31	27B	PED. ISD. COMN.	J1-27B
28A	ADDR. SEL. 0	-----	28A	ADDR. SEL. 0	J2-32A
28B	ADDR. SEL. 1	-----	28B	ADDR. SEL. 1	-----
29A	ADDR. SEL. 2	-----	29A	ADDR. SEL. 2	-----
29B	ADDR. SEL. 3	-----	29B	ADDR. SEL. 3	-----
30A	RESERVED	-----	30A	RESERVED	-----
30B	RESERVED	-----	30B	RESERVED	-----
31A	EARTH GND.	LS12-2	31A	EARTH GND.	J1-31A
31B	LINE FREQ. REF.	J3-29	31B	LINE FREQ. REF.	J1-31B
32A	LOGIC GND.	B-14	32A	LOGIC GND.	J1-32B
32B	LOGIC GND.	J2-32A	32B	LOGIC GND.	J2-32A

MAIN PANEL CONTROL POWER C/C 34842G4	
PIN	FUNCTION
1	LOGIC GROUND
2	+24 VDC (IN)
3	-----
4	MMU FAULT MONITOR (IN)
5	LINE FREQ. REFERENCE (IN)
6	-----
7	+12 VAC (IN)
8	SIGNAL BUS CONTROL (IN)
9	-----
10	FILTERED AC NEUTRAL (IN)
11	CONT. EQUIP. AC LINE (OUT)
12	FILTERED AC LINE (IN)

CONTROLLER POWER (CCA2) C/C 34842G3			
WIRE	PIN	SIGNAL	TO
1	A	FAULT MONITOR	PB-4
2	U	AC NEUTRAL	PB-10
3	V	EARTH GROUND	PB-9
4	W	LOGIC GROUND	PB-1
5	P	AC LINE	PB-11
6	SHL	EARTH GROUND	CCA2-V

TYPE 1 CONTROLLER POWER C/C 34842G2		
PIN	FUNCTION	TO
A	AC NEUTRAL	PB-10
B	-----	-----
C	AC LINE	PB-11
D	-----	-----
E	+12 VDC	PB-3
F	+24 VDC	PB-2
G	RESERVED	-----
H	LOGIC GND.	PB-1
I	EARTH GND.	PB-9
J	+12 VAC	PB-7
K	RESERVED	-----
L	-----	-----
SHL	EARTH GND.	PIN H

CABINET POWER SUPPLY C/C 34842G1		
PIN	FUNCTION	TO
A	AC NEUTRAL	PB-10
B	LINE FREQUENCY REF.	PB-5
C	AC LINE	PB-11
D	+12 VDC	PB-3
E	+24 VDC	PB-2
F	RESERVED	-----
G	LOGIC GND.	PB-1
H	EARTH GND.	PB-9
I	+12 VAC	PB-7
J	RESERVED	-----
SHL	EARTH GND.	PIN H

CONTROLLER PORT 1 CONNECTOR			
PIN	SIGNAL	TO	FUNCTION
1	TWISTED PAIR 1+	SDLC-1	CONT TXD+
2	LOGIC GND.	-----	-----
3	TWISTED PAIR 2+	SDLC-4	CONT TXC+
4	LOGIC GND.	-----	-----
5	TWISTED PAIR 3+	SDLC-7	CONT RXD+
6	LOGIC GND.	-----	-----
7	TWISTED PAIR 4+	SDLC-10	CONT RXC+
8	LOGIC GND.	-----	-----
9	TWISTED PAIR 1-	SDLC-2	CONT TXD-
10	PORT 1 DISABLE	-----	-----
11	TWISTED PAIR 2-	SDLC-5	CONT TXC-
12	EARTH GND.	SHIELD WIRE	-----
13	TWISTED PAIR 3-	SDLC-8	CONT RXD-
14	RESERVED	-----	-----
15	TWISTED PAIR 4-	SDLC-11	CONT RXC-

MMU & BIU PORT 1 CONNECTOR			
PIN	SIGNAL	TO	FUNCTION
1	TWISTED PAIR 1+	SDLC-1	BIU RXD+
2	LOGIC GND.	-----	-----
3	TWISTED PAIR 2+	SDLC-4	BIU RXC+
4	LOGIC GND.	-----	-----
5	TWISTED PAIR 3+	SDLC-7	BIU TXD+
6	LOGIC GND.	-----	-----
7	TWISTED PAIR 4+	SDLC-10	BIU TXC+
8	LOGIC GND.	-----	-----
9	TWISTED PAIR 1-	SDLC-2	BIU RXD-
10	PORT 1 DISABLE	-----	-----
11	TWISTED PAIR 2-	SDLC-5	BIU RXC-
12	EARTH GND.	SHIELD WIRE	-----
13	TWISTED PAIR 3-	SDLC-8	BIU TXD-
14	RESERVED	-----	-----
15	TWISTED PAIR 4-	SDLC-11	BIU TXC-

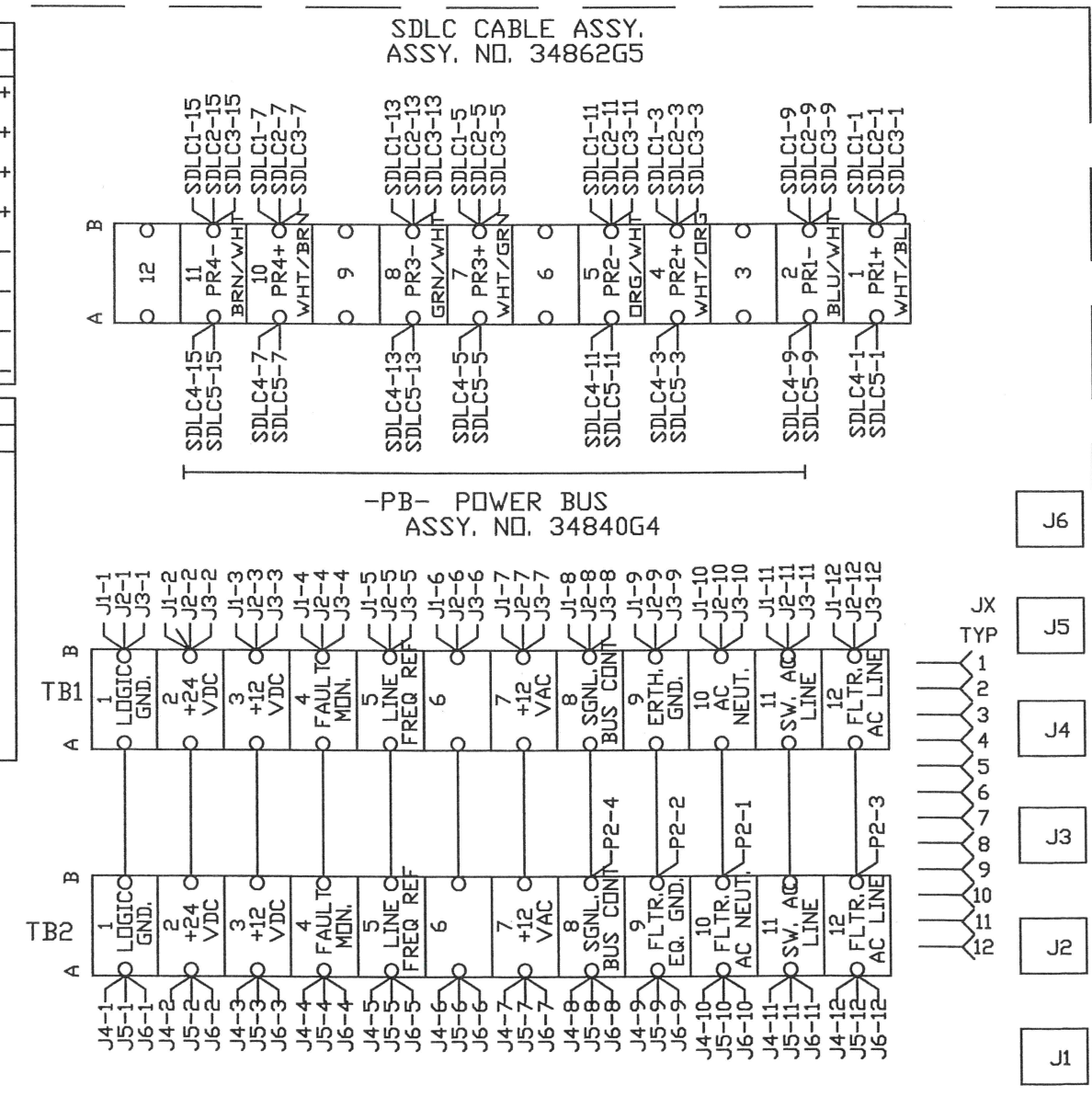
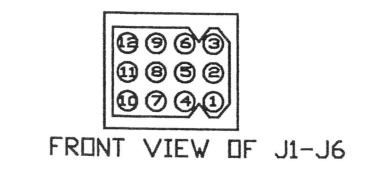
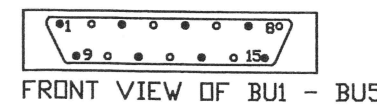

WIRE LIST FOR NEMA MALFUNCTION MANAGEMENT UNIT

CONNECTOR "A" (MMA)				CONNECTOR "B" (MMB)			
PIN	WIRE	MON. FUNCTION	SIG. FUNCTION	PIN	WIRE	MON. FUNCTION	SIG. FUNCTION
A	A-1	AC+ I INPUT	B21	A	B-1	AC+ II INPUT	J3-2
B	A-2	OUT RLY 1 OPEN	B22	B	B-2	S. DLY RLY COMM.	J3-6
C	A-3	OUT RLY 2 CLSD	B23	C	B-3	S. DLY RLY OPEN	B28
D	A-4	CH. 12 GREEN	12G-A	D	B-4	CH. 12 RED	B40
E	A-5	CH. 11 GREEN	11G-A	E	B-5	CH. 11 RED	B39
F	A-6	CH. 10 GREEN	10G-A	F	B-6	CH. 9 RED	B37
G	A-7	CH. 9 GREEN	9G-A	G	B-7	CH. 8 RED	8R-A
H	A-8	CH. 8 GREEN	8G-A	H	B-8	CH. 7 RED	7R-A
J	A-9	CH. 7 GREEN	7G-A	J	B-9	CH. 6 RED	6R-A
K	A-10	CH. 6 GREEN	6G-A	K	B-10	CH. 5 RED	5R-A
L	A-11	CH. 5 GREEN	5G-A	L	B-11	CH. 4 RED	4R-A
M	A-12	CH. 4 GREEN	4G-A	M	B-12	CH. 2 RED	2R-A
N	A-13	CH. 3 GREEN	3G-A	N	B-13	CH. 1 RED	1R-A
P	A-14	CH. 2 GREEN	2G-A	P	B-14	(SPARE 1)	B29
R	A-15	CH. 1 GREEN	1G-A	R	B-15	+24V MONITOR II	B-3
S	A-16	+24V MON. I	B-4	S	B-16	(SPARE 2)	B30
T	A-17	LOGIC GND	B-14	T	B-17	CH. 13 RED	13R-A
U	A-18	CHASSIS GND	LS7-2	U	B-18	S. DLY RLY CLSD	J3-35
V	A-19	AC- (COMMON)	K1-2	V	B-19	CH. 10 RED	B38
W	A-20	OUT RLY 1 COM.	J3-7	W	B-20	CH. 14 RED	14R-A
X	A-21	OUT RLY 2 COM.	A-27	X	B-21	CH. 15 RED	15R-A
Y	A-22	CH. 12 YELLOW	-T-	Y	B-22	CH. 16 RED	16R-A
Z	A-23	CH. 11 YELLOW	-T-	Z	B-23	CH. 3 RED	3R-A
a	A-24	CH. 10 WALK	----	a	B-24	RED ENABLE	LS8-1
b	A-25	CH. 10 YELLOW	-T-	b	B-25	(SPARE 3)	B31
c	A-26	CH. 9 YELLOW	-T-	c	B-26	LOCAL FLASH IN	CAPPED
d	A-27	CH. 8 YELLOW	8Y-A		B-27	SHELL GROUND	LS6-2
e	A-28	CH. 7 YELLOW	7Y-A				
f	A-29	CH. 6 YELLOW	6Y-A				
g	A-30	CH. 5 YELLOW	5Y-A				
h	A-31	CH. 3 YELLOW	3Y-A				
i	A-32	CH. 15 GREEN	15G-A				
j	A-33	CH. 2 YELLOW	2Y-A				
k	A-34	CH. 1 YELLOW	1Y-A				
m	A-35	CONT. VOLT. MON.	B-5				
n	A-36	+24V MON. INH.	B-2				
p	A-37	OUT RLY 1 CLSD	J3-3				
q	A-38	OUT RLY 2 OPEN	A-31				
r	A-39	CH. 12 WALK	----				
s	A-40	CH. 11 WALK	----				
t	A-41	CH. 9 WALK	----				
u	A-42	CH. 16 YELLOW	16Y-A				
v	A-43	CH. 15 YELLOW	15Y-A				
w	A-44	CH. 13 YELLOW	13Y-A				
x	A-45	CH. 4 YELLOW	4Y-A				
y	A-46	CH. 14 GREEN	14G-A				
z	A-47	CH. 13 GREEN	13G-A				
AA	A-48	(SPARE 1)	B24				
BB	A-49	RESET	B-1				
CC	A-50	CAB. INTLK A	B25				
DD	A-51	CAB. INTLK B	B26				
EE	A-52	CH. 14 YELLOW	14Y-A				
FF	A-53	CH. 16 GREEN	16G-A				
GG	A-54	(SPARE 2)	B27				
HH	A-55	TYPE SELECT	A-20				
	A-56	SHELL GND	LS15-2				

NOTES FOR 16 CHANNEL M.M.U.

- (1) RELAY CONTACT POSITIONS SPECIFIED ARE FOR NON-CONFLICT MODE.
- (2) TO PROGRAM MMU, SOLDER JUMPERS IN PROGRAMMING CARD FOR ALL PERMISSABLE PHASE MOVEMENTS, MINIMUM CHANGE DIS-ABLE FOR ALL PEDESTRIAN CHANNELS, AND MIN. FLASH, VOLTAGE MON., AND 24V. MON. LATCH OPTIONS AS DESIRED.

M.M.U. CHANNEL ASSIGNMENTS

- CH. 1 = L/S 1 = ^1 VEH.
- CH. 2 = L/S 2 = ^2 VEH.
- CH. 3 = L/S 3 = ^3 VEH.
- CH. 4 = L/S 4 = ^4 VEH.
- CH. 5 = L/S 5 = ^5 VEH.
- CH. 6 = L/S 6 = ^6 VEH.
- CH. 7 = L/S 7 = ^7 VEH.
- CH. 8 = L/S 8 = ^8 VEH.
- CH. 9 = L/S 9 = ^2 PED.
- CH. 10 = L/S 10 = ^4 PED.
- CH. 11 = L/S 11 = ^6 PED.
- CH. 12 = L/S 12 = ^8 PED.
- CH. 13 = L/S 13 = OLAP A
- CH. 14 = L/S 14 = OLAP B
- CH. 15 = L/S 15 = OLAP C
- CH. 16 = L/S 16 = OLAP D

MMU PROGRAM CARD

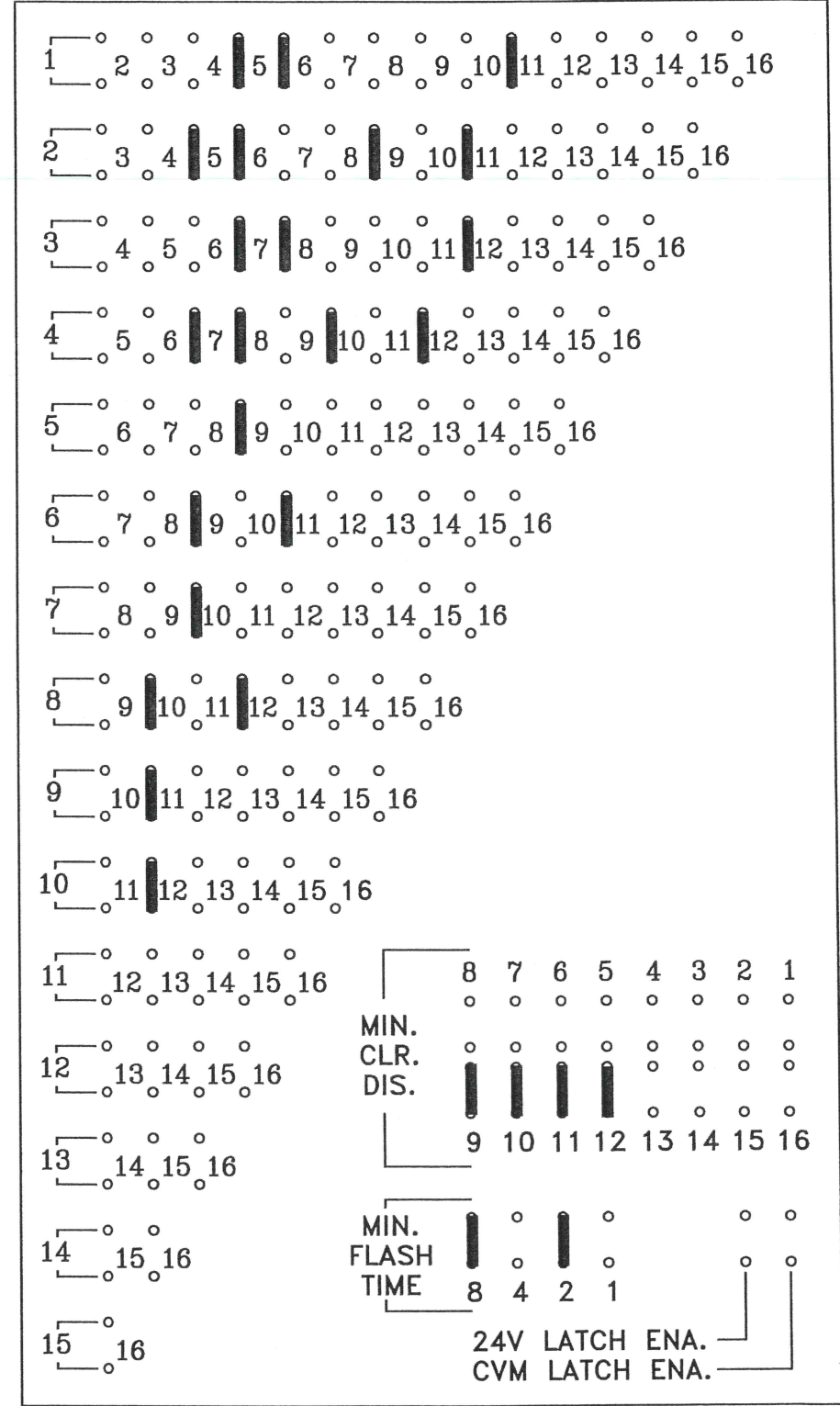

M.M.U. C/C'S AND PROGRAM CARD

DETECTOR RACK 34030G1

POWER SUPPLY OR B.I.U.	L3	L1	L7	L5	L11	L9	L15	L13	PMT 5 8 <input type="checkbox"/> 2CH OPTICOM/ OPIC CH. C CH. D 4	PMT 3 1-6 <input type="checkbox"/> 4CH <input type="checkbox"/> 2CH OPTICOM/ OPIC CH. A CH. B 2-5	PGM. CARD
	5-1	1-1	6-1	2-1	4-3	4-1	8-3	8-1			
	<input type="checkbox"/> 2CH 5-2	<input type="checkbox"/> 2CH 1-2	<input type="checkbox"/> 2CH 6-2	<input type="checkbox"/> 2CH 2-2	<input type="checkbox"/> 2CH ∅	<input type="checkbox"/> 2CH 4-2	<input type="checkbox"/> 2CH ∅	<input type="checkbox"/> 2CH 8-2	<input type="checkbox"/> 2CH 8-2		
	L4	L2	L8	L6	L12	L10	L16	L14	PMT 6	PMT 4	

J13 C/C 33284G10 DC POWER	J16 C/C 33284G8 EXP. OUTPUTS	J14 C/C 33284G2 LPS 1-8	J18 C/C 33284G9 SYS. OUTPUTS	J15 C/C 33284G3 LPS 9-16	J17 C/C 33284G6 AC POWER	J19 C/C 33284G17 PGM. CARD
---------------------------------	------------------------------------	-------------------------------	------------------------------------	--------------------------------	--------------------------------	----------------------------------

①

ADDRESS TABLE					
RACK #	JMPR	DET. #'S	RACK #	JMPR	DET. #'S
1		1-16	5		65-80
2		17-32	6		81-96
3		33-48	7		97-112
4		49-64	8		113-128

DETECTOR ASSIGNMENTS		
CONT. INPUT	PHASE ASGN.	DETECTOR TYPE
1	1-1	1
2	1-2	1
3	5-1	1
4	5-2	1
5	2-1	1
6	2-2	1
7	6-1	1
8	6-2	1
9	4-1	1
10	4-2	1
11	4-3	1
12		
13	8-1	1
14	8-2	1
15	8-3	1
16		
17		
18		
19		
20		
21		
22		
23		
24		
25		
26		
26		
28		
29		
30		
31		
32		
33		
34		
35		
36		

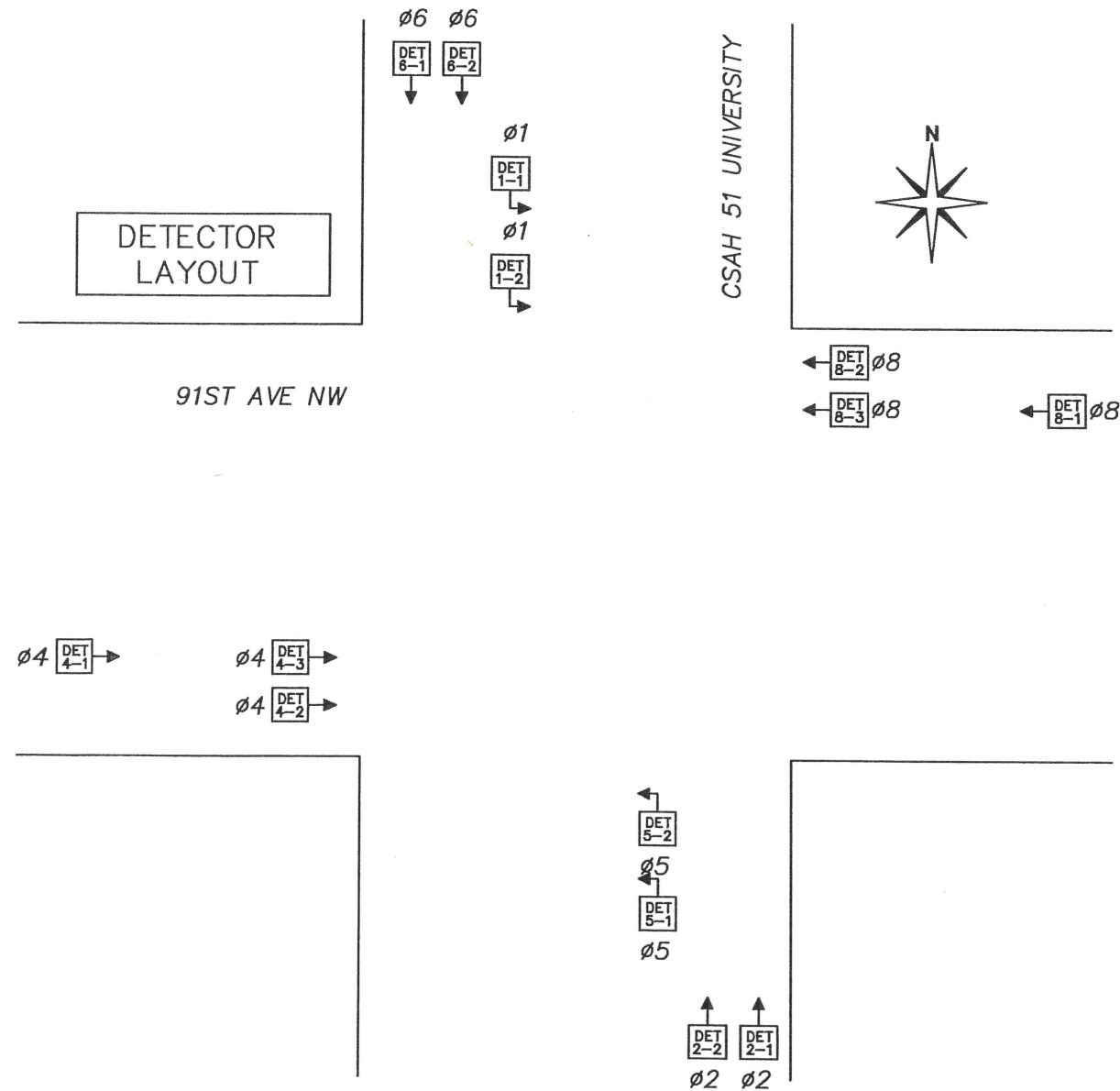

		DETECTOR RACK PROGRAMMING JUMPERS																													
DET. TYPE		SLOT 1/2 ①								SLOT 3/4 ①								SLOT 5/6 ①								SLOT 7/8 ①					
		JP1	JP2	JP3	JP4	JP5	JP6	JP7	JP8	JP9	JP10	JP11	JP12	JP13	JP14	JP15	JP16	JP17	JP18	JP19	JP20	JP21	JP22	JP23	JP24	JP25	JP26	JP27	JP28	JP29	JP30
①	TS-1	NO	NO																												
②	TS-2	YES	YES																												
③	LM-632T 262-FC	NO	NO																												
④	MAG.	NO	NO																												

DETECTOR LOOP
INTERFACE
ASSY. 34040G1

J1
TO DR1: J14
C/C 33284G2

J2
TO DR1: J15
C/C 33284G3

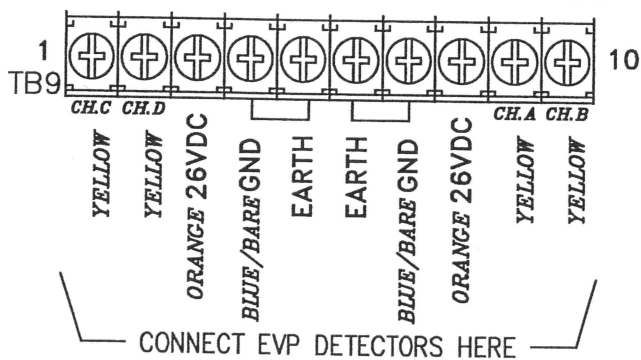
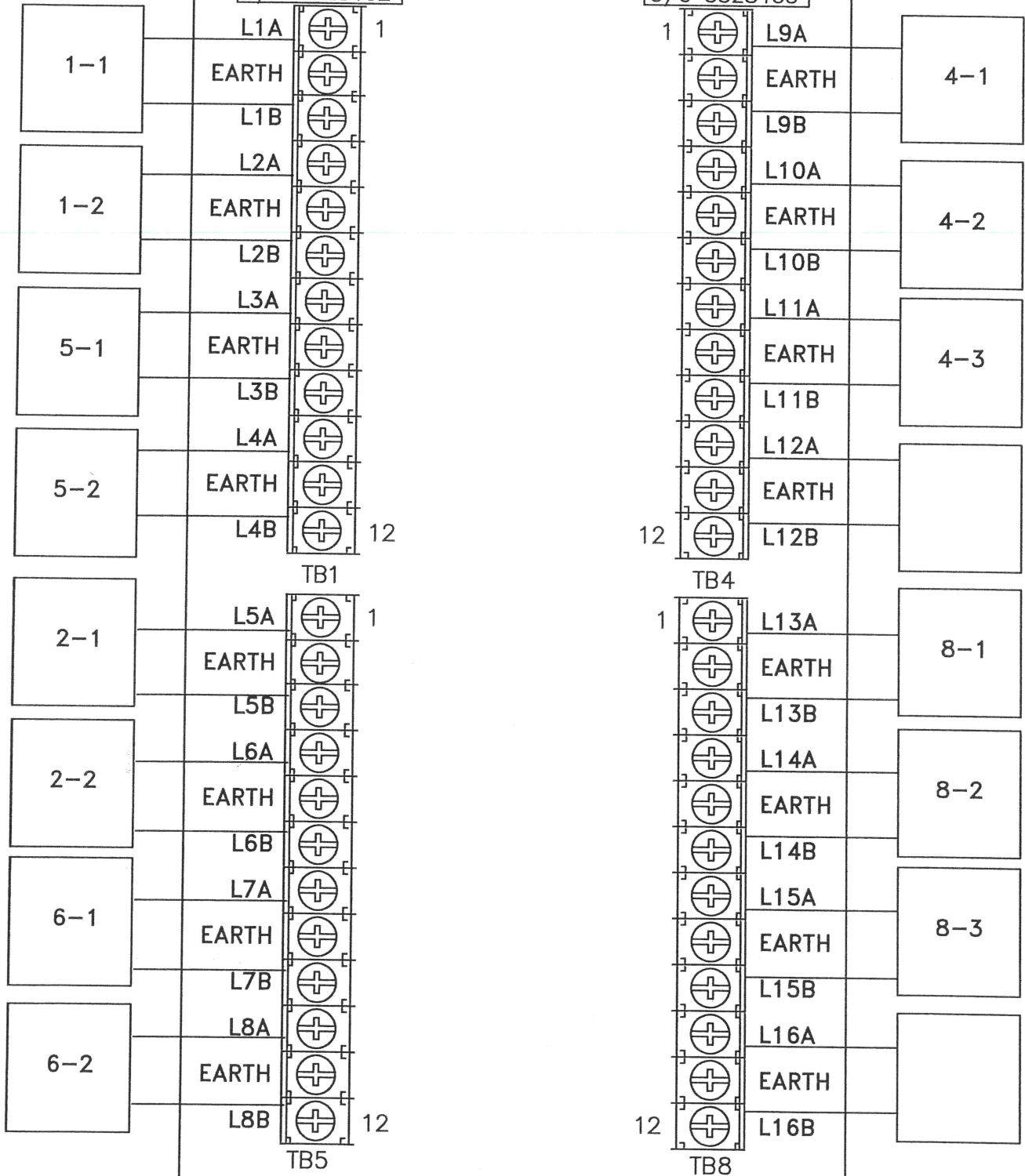

DET. LOOPS 9-16 (J15) C/C 33284G3

PIN	SIGNAL	TO
1	LOOP 9+	LPI2: TB4-1
2	LOOP 9-	LPI2: TB4-3
3	LOOP 10+	LPI2: TB4-4
4	LOOP 10-	LPI2: TB4-6
5	LOOP 11+	LPI2: TB4-7
6	LOOP 11-	LPI2: TB4-9
7	LOOP 12+	LPI2: TB4-10
8	LOOP 12-	LPI2: TB4-12
9	LOOP 13+	LPI2: TB8-1
10	LOOP 13-	LPI2: TB8-3
11	LOOP 14+	LPI2: TB8-4
12	LOOP 14-	LPI2: TB8-6
13	LOOP 15+	LPI2: TB8-7
14	LOOP 15-	LPI2: TB8-9
15	LOOP 16+	LPI2: TB8-10
16	LOOP 16-	LPI2: TB8-12
17	----	
18	----	
19	----	
20	----	

DET. LOOPS 1-8 (J14) C/C 33284G2

PIN	SIGNAL	TO
1	LOOP 1+	LPI1: TB1-1
2	LOOP 1-	LPI1: TB1-3
3	LOOP 2+	LPI1: TB1-4
4	LOOP 2-	LPI1: TB1-6
5	LOOP 3+	LPI1: TB1-7
6	LOOP 3-	LPI1: TB1-9
7	LOOP 4+	LPI1: TB1-10
8	LOOP 4-	LPI1: TB1-12
9	LOOP 5+	LPI1: TB5-1
10	LOOP 5-	LPI1: TB5-3
11	LOOP 6+	LPI1: TB5-4
12	LOOP 6-	LPI1: TB5-6
13	LOOP 7+	LPI1: TB5-7
14	LOOP 7-	LPI1: TB5-9
15	LOOP 8+	LPI1: TB5-10
16	LOOP 8-	LPI1: TB5-12
17	PMT. DET. CH. C	LPI1: TB9-1
18	PMT. DET. CH. D	LPI1: TB9-2
19	KEY PIN	
20	PMT. CH. C/D +26VDC	LPI1: TB9-3
21	PMT. DC GROUND	LPI1: TB9-4,7
22	PMT. CH. A/B +26VDC	LPI1: TB9-8
23	PMT. DET. CH. A	LPI1: TB9-9
24	PMT. DET. CH. B	LPI1: TB9-10
25	----	
26	----	

DET. RACK POWER C/C 34842G5			
P1/ DR: J13	P2/ DR: J17	FUNCTION	TO
1		+12 VDC (DET. POWER)	PB-3
2		+24 VDC (BIU POWER)	PB-2
3		LOGIC GROUND	PB-1
4		EARTH GROUND	PB-9
5		"KEY PIN"	
6		LINE FREQUENCY REF.	PB-5
	1	EARTH GROUND	----
	2	AC LINE	PB-12
	3	AC NEUTRAL	PB-10
	4	LOGIC GROUND	----

EXPANSION OUTPUTS C/C 33284G8		
J16	FUNCTION	TO
17	DET. 17 / PMT. A OUT	MP: B19
18	DET. 18 / PMT. B OUT	MP: B20
19	PMT. C OUT	MP: B17
20	PMT. D OUT	MP: B18

DETECTOR LOOP INTERFACE

