

ASC/2S-2100 CONTROLLER WITH:

- CONFIGURATION EEPROM 32790C1440
- SOFTWARE: V1.72
- SPECIAL SOFTWARE: SEE BELOW FUNCTION
- OVERLAPS
  - IN EEPROM
  - KEYBOARD ENTERED
- ANALOG TELEMETRY MODULE: 32825G1
- F/O TELEMETRY MODULE: 33525G1
- TEST INPUT A =
- TEST INPUT B =

A =  
B =  
C =  
D =

LEGEND

BIU	BUS INTERFACE UNIT
BU()	C/C, BIU ()
CB()	CIRCUIT BREAKER ()
C/C	CONNECTING CABLE
CCA	CONTROLLER CABLE "A"
CDP	C/C, DR POWER
CMA	MMU/CMU CABLE "A"
CMB	MMU/CMU CABLE "B"
CPO	C/C PRE-EMPT OUTPUTS
CPP	C/C PRE-EMPT POWER
DR	DETECTOR RACK
DS()	DOOR SWITCH ()
FL()	FLASHER ()
FR()	FLASH XFER. RELAY
LS()	LOAD SWITCH
MC	MERCURY CONTACTOR
MP	MAIN PANEL
PAP	POWER-AUX PANEL
PSP	CAB. PWR. SUPPLY
SA	SURGE ARRESTOR
TB-()	TERM. BLOCK ()

MAIN PANEL PLUG-IN REQUIREMENTS

<input checked="" type="checkbox"/> BIU2 T&F	<input type="checkbox"/> BIU3 T&F	<input checked="" type="checkbox"/> LS9 PED 2 BEACONS	<input checked="" type="checkbox"/> LS10 PED 4 BEACONS	<input checked="" type="checkbox"/> LS11 PED 6 BEACONS	<input checked="" type="checkbox"/> LS12 PED 8 BEACONS	<input type="checkbox"/> LS13 OL "A"	<input type="checkbox"/> LS14 OL "B"	<input type="checkbox"/> LS15 OL "C"	<input type="checkbox"/> LS16 OL "D"
<input checked="" type="checkbox"/> BIU1 T&F	<input type="checkbox"/> LS1 VEH 1	<input type="checkbox"/> LS2 VEH 2	<input type="checkbox"/> LS3 VEH 3	<input type="checkbox"/> LS4 VEH 4	<input type="checkbox"/> LS5 VEH 5	<input type="checkbox"/> LS6 VEH 6	<input type="checkbox"/> LS7 VEH 7	<input type="checkbox"/> LS8 VEH 8	<input type="checkbox"/> FL1 <input type="checkbox"/> 1CKT <input checked="" type="checkbox"/> 2CKT
<input checked="" type="checkbox"/> FR1	<input checked="" type="checkbox"/> FR2	<input checked="" type="checkbox"/> FR3	<input checked="" type="checkbox"/> FR4	<input checked="" type="checkbox"/> FR5	<input checked="" type="checkbox"/> FR6	<input checked="" type="checkbox"/> K1			
<input type="checkbox"/> L R V1 V5	<input type="checkbox"/> L R V2 V6	<input type="checkbox"/> L R V3 V7	<input type="checkbox"/> L R V4 V8	<input type="checkbox"/> L R A C	<input type="checkbox"/> L R B D	<input checked="" type="checkbox"/> LS 24V CONT.			

DENOTES TYPE OF OPERATION AND/OR WHERE PLUG-IN IS REQUIRED. L = LEFT, R = RIGHT.  
 DENOTES WHERE "UNUSED RED" JUMPER PART NUMBER 32448G1 IS REQUIRED. INSTALL BETWEEN PINS 1 & 3 FOR LOAD SWITCH OR PINS 6 & 8 AND 5 & 7 FOR FLASH TRANSFER RELAY.

FLASH:  
 ø2&6 YELLOW, ALL OTHERS RED.  
 ALL RED.  
 RELAYS DE-ENERGIZED FOR FLASH.  
 RELAYS ENERGIZED FOR FLASH.

FLASHER	
PIN	FUNCTION
7	CIRCUIT #1
8	CIRCUIT #2
9	CHASSIS GND
10	AC COMMON
11	115 VAC
12	-----

LOAD SWITCH	
PIN	FUNCTION
1	115 VAC
2	CHASSIS GND
3	RED/DW OUTPUT
4	-----
5	YEL OUTPUT
6	RED/DW INPUT
7	GRN/W OUTPUT
8	YEL INPUT
9	+24 VDC
10	GRN/W INPUT
11	AC COMMON
12	-----

① 2.2K  
10W

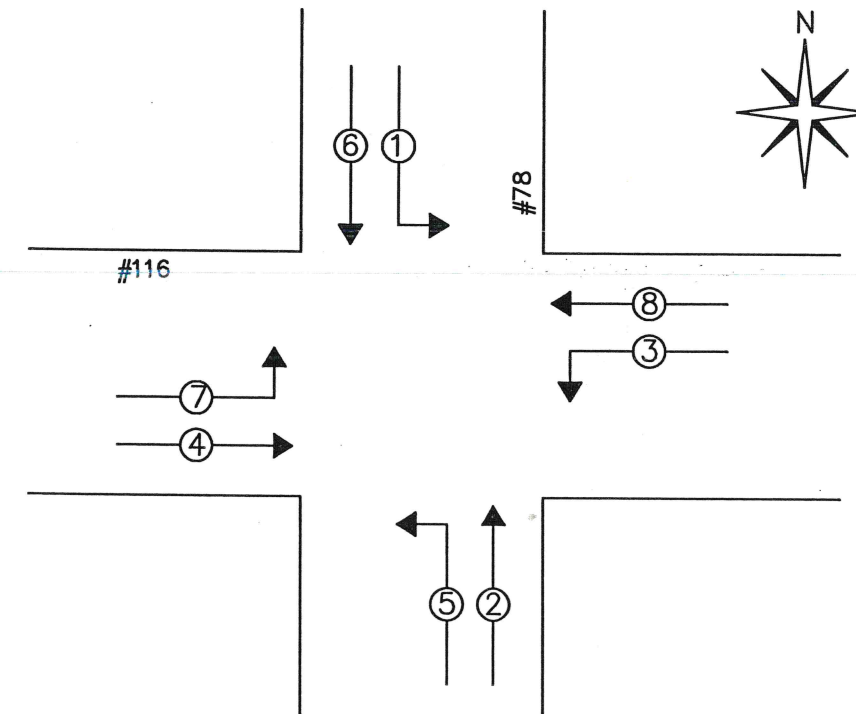

SHEET 1 OF 11

- 3 USE ONLY COPPER CONDUCTORS FOR FIELD AND SERVICE CONNECTIONS.
- 2 CONNECT A.C. SERVICE TO TERMINAL BLOCK 501 (LINE), 502 (NEUTRAL) AND GB2 (EARTH) ON RIGHT SIDEWALL OF CABINET.
- ① INSTALL 2.2K, 10 WATT LOAD RESISTORS BETWEEN PINS 7 AND 11 ON LOAD SWITCHES 9, 10, 11 & 12.

NOTES: UNLESS SPECIFIED OTHERWISE

DESIGNER G.V. T.C.C.	DATE 02/03/97	<b>ECONOLITE</b> CONTROL PRODUCTS INC.	<b>TRAFFIC CONTROL CORPORATION</b>	5653 MEMORIAL AVE. OAK PARK HTS, MN 55082
DRAWN MARK L.	DATE 02/09/07			CABINET SPECIFICATION: TS2TYPE1 2004 ANOKA COUNTY
CABINET SIZE		CUSTOMER: ANOKA COUNTY HIGHWAY DEPARTMENT		FLASHER
INSPECTED		INTERSECTION: #78 AT #116		SW.PACKS
APPROVED		LOCATION: COON RAPIDS		
CUSTOMER P.O.		SYSTEM:		
	INSTALLED BY	SALES ORDER NO.	SIZE B	DRAWING #TS20216PG INTERC

**AUXILLARY SWITCH PANEL**

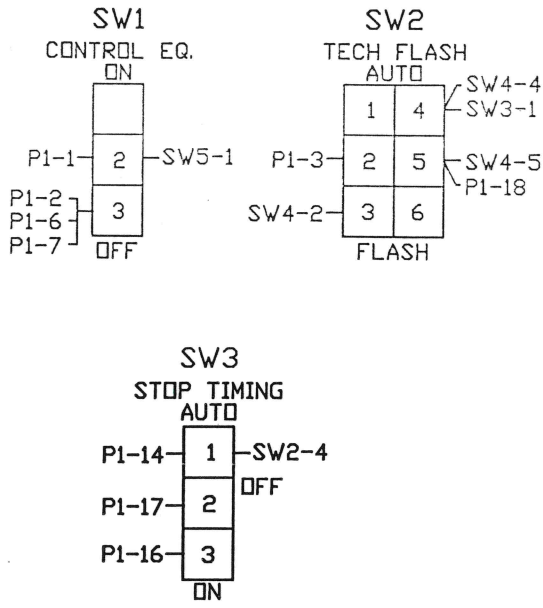

**POLICE SWITCH PANEL**

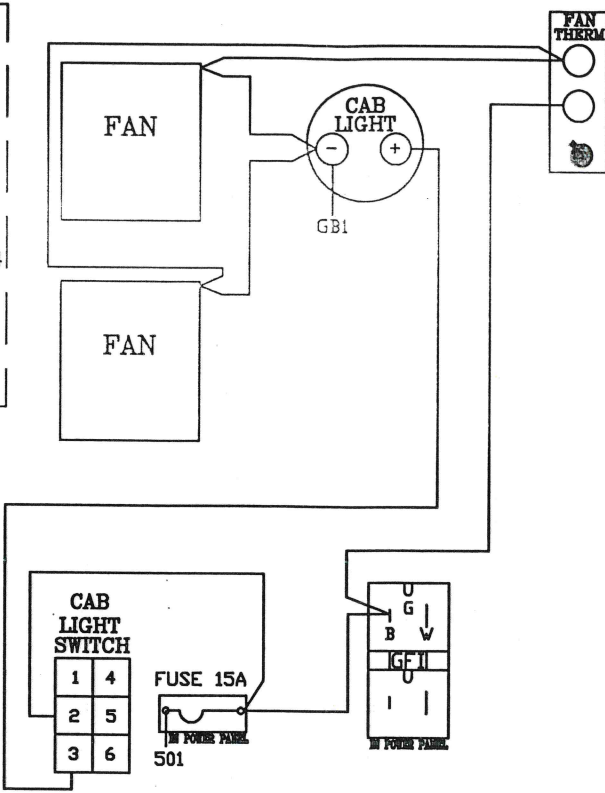
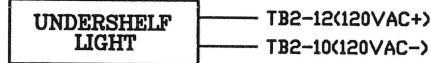
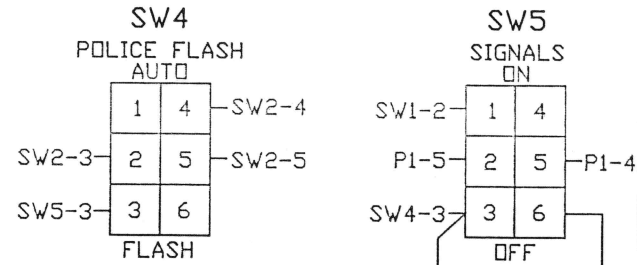

**POWER/AUX PANEL (PAP) 34830G5**

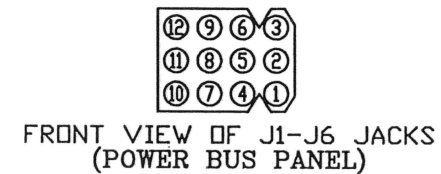
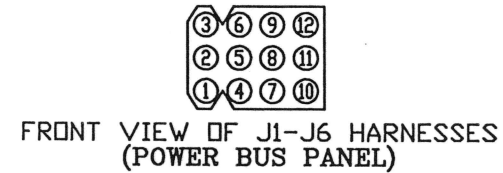
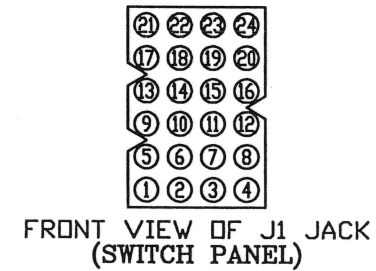
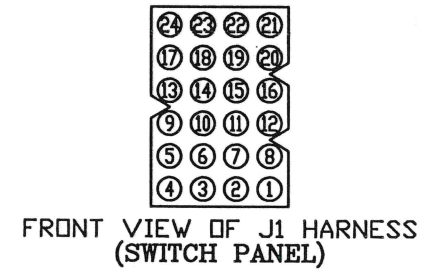
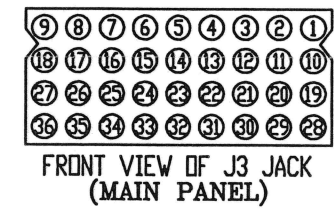
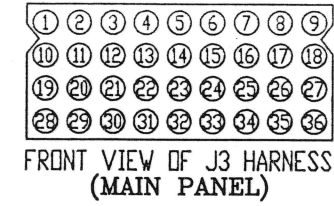
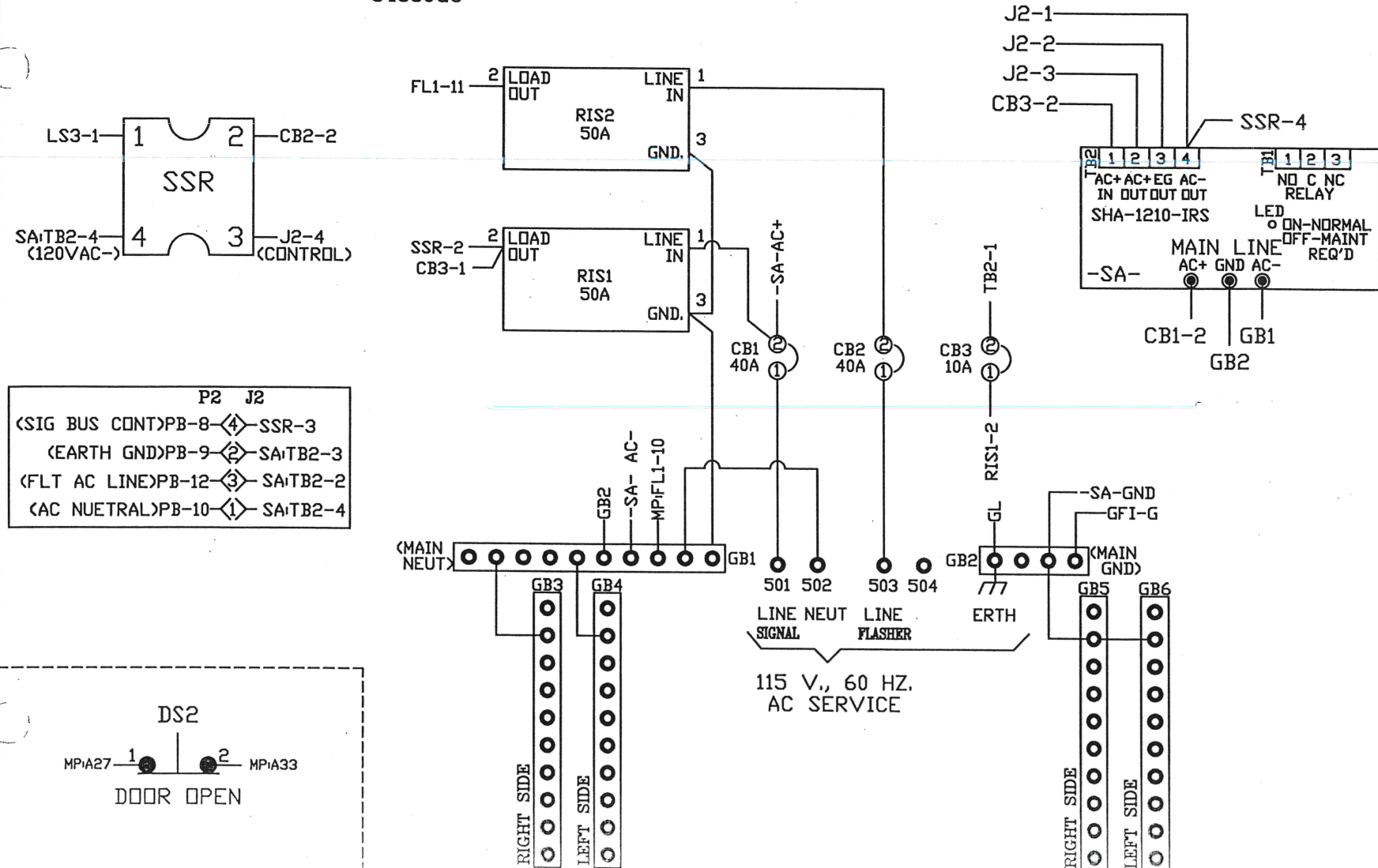

J3		P1	
J3-36	1 FILTER AC LINE (OUT)	P1-1	SW1-2
MMB-1	2 SWITCHED AC LINE (IN)	P1-2	SW1-3
MMA-37	3 FLASH CONTROL BUS (OUT)	P1-3	SW2-3
K1-10	4 SIGNAL BUS CONTROL (IN)	P1-4	SW5-5
FR6-2	5 FLASH RELAY CONTROL (IN)	P1-5	SW5-2
MMB-2	6 START DELAY AC BUS (IN)	P1-6	SW1-3
MMA-20	7 MMU FLASH CONTROL BUS (IN)	P1-7	SW1-3
	8 SPARE	P1-8	----
	9 SPARE	P1-9	----
	10 SPARE	P1-10	----
	11 SPARE	P1-11	----
	12 SPARE	P1-12	----
A-39	13 OPT-MANUAL CONT. ENABLE (IN)	P1-13	----
A-35	14 LOGIC GROUND	P1-14	SW3-1
A-40	15 OPT-INTERVAL ADVANCE (IN)	P1-15	----
A-31	16 MMU STOP TIME (OUT)	P1-16	SW3-3
A-30	17 CONTROLLER STOP TIME (IN)	P1-17	SW3-2
A-32	18 LOCAL FLASH STATUS (IN)	P1-18	SW2-5
A-38	19 OPT-COORD FREE (IN)	P1-19	----
A-33	20 OPT-ALARM 1 (IN)	P1-20	----
A-34	21 OPT-ALARM 2 (IN)	P1-21	----
K1-9	22 OPT-LOADSWITCH TEST (IN)	P1-22	----
B-3	23 MMU 24V MON. 2 (IN)	P1-23	----
B-4	24 +24 VDC	P1-24	----

J3		J1	
A-35	25 LOGIC GROUND	J1-1	TB1-1
K1-11	26 +24 VDC (IN)	J1-2	TB1-2
	27 ----	J1-3	TB1-3
B-5	28 MMU FAULT MONITOR (IN)	J1-4	TB1-4
J1-31B	29 LINE FREQ. REFERENCE (IN)	J1-5	TB1-5
	30 ----	J1-6	TB1-6
J1-27B	31 +12 VAC (IN)	J1-7	TB1-7
K1-10	32 SIGNAL BUS CONTROL (IN)	J1-8	TB1-8
	33 ----	J1-9	TB1-9
K1-2	34 FILTERED AC NEUTRAL (IN)	J1-10	TB1-10
MMB-18	35 CONT. EQUIP. AC LINE (OUT)	J1-11	TB1-11
J3-1	36 FILTERED AC LINE (IN)	J1-12	TB1-12

# CONFIRMATION BEACONS

EVP 3 = 1-6 SB  
 EVP 4 = 2-5 NB  
 EVP 5 = 3-8 WB  
 EVP 6 = 4-7 EB

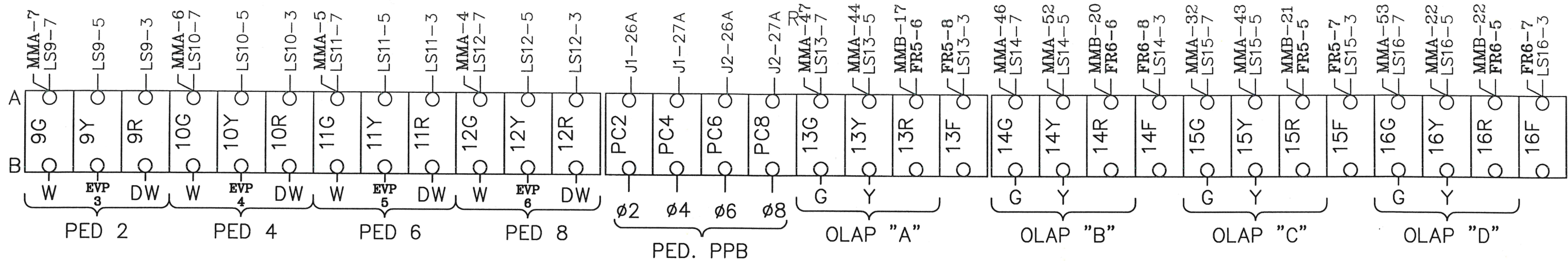

(P.B. COMMON TO GB1)

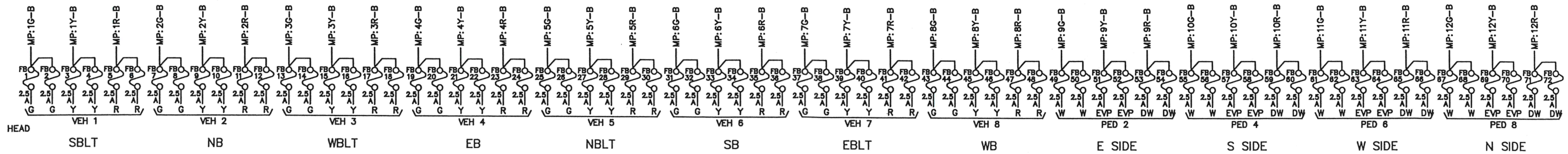
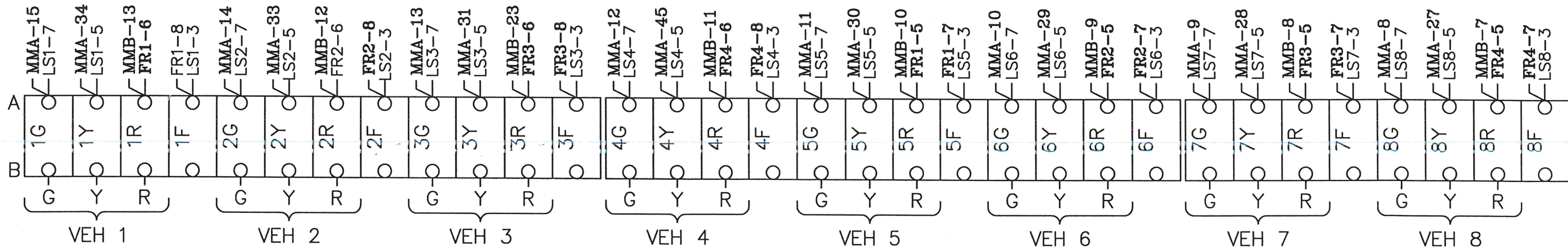

2.2K  
10W

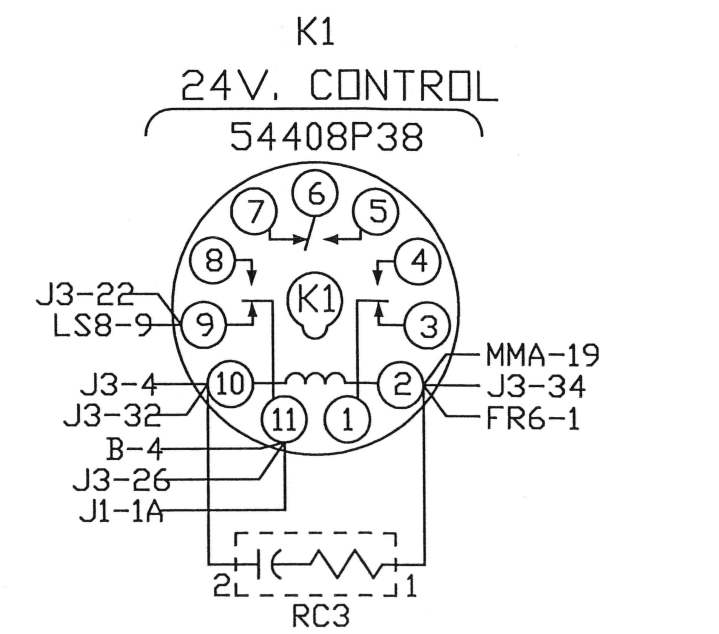
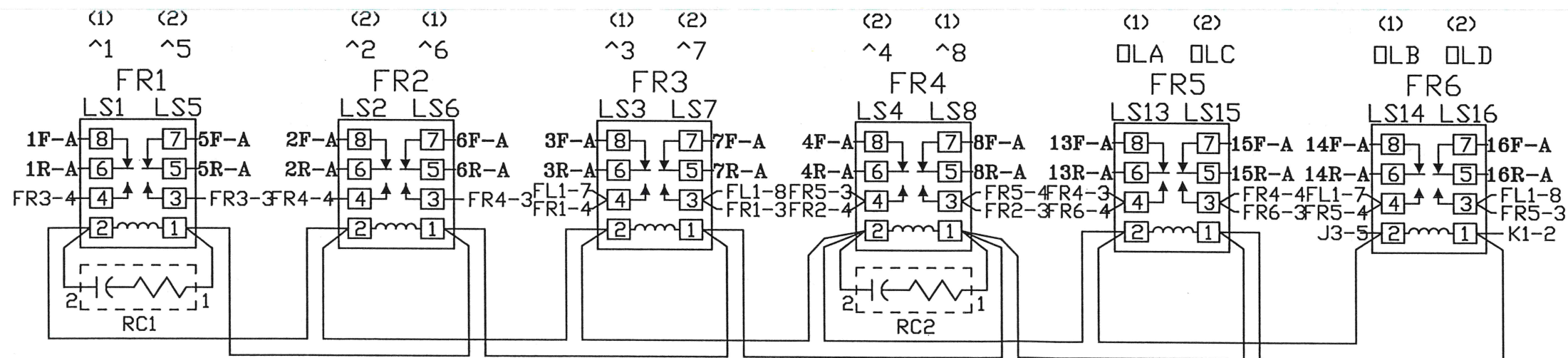
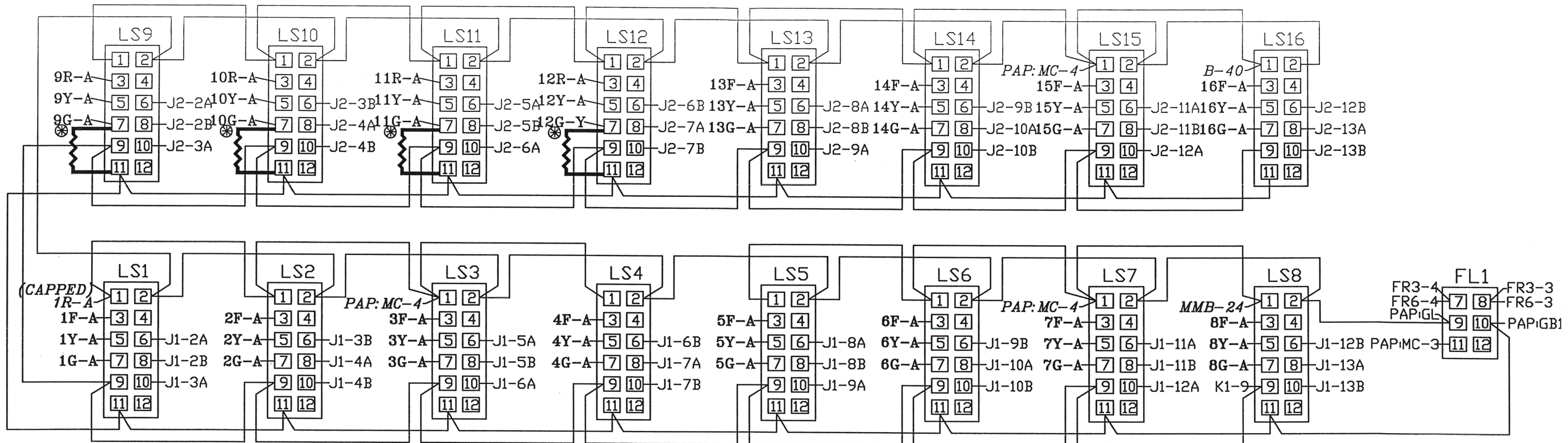

LOADBAY AND FLASH RELAY'S

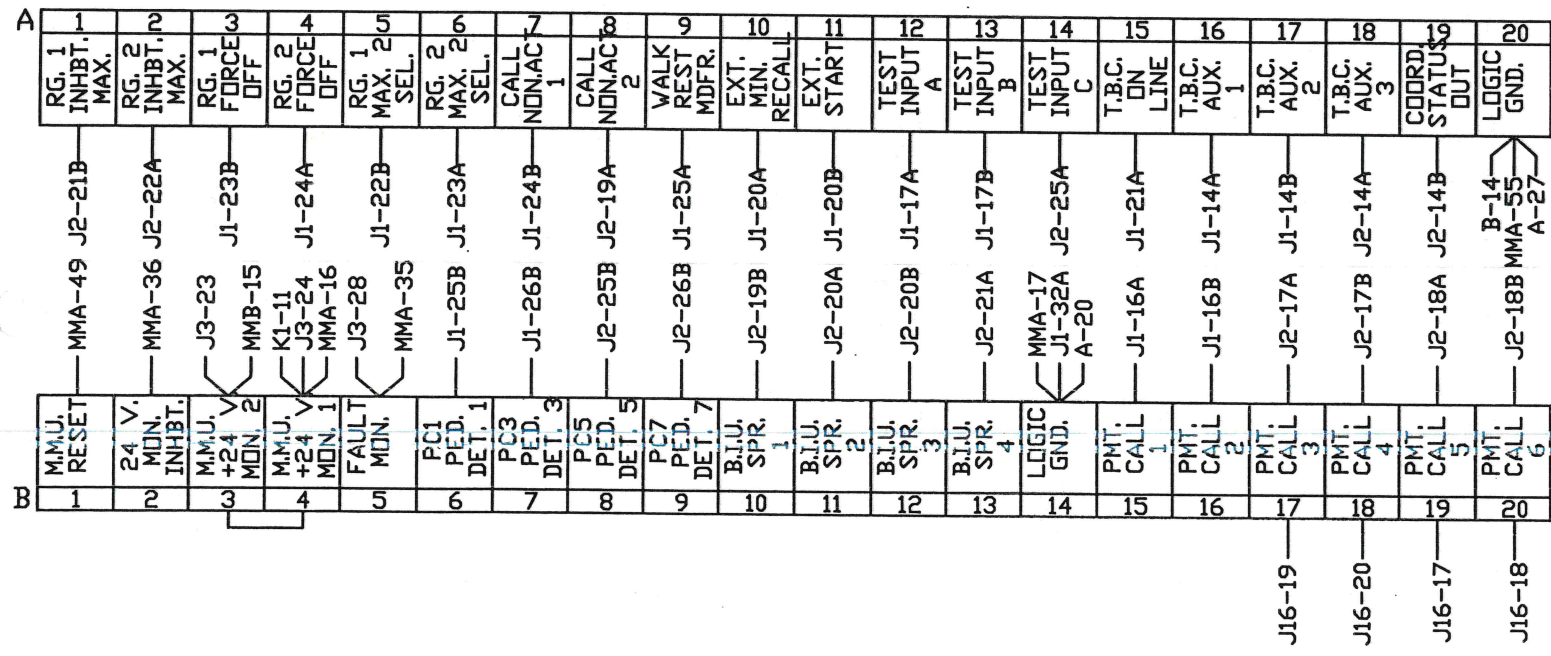

J16-19  
J16-20  
J16-17  
J16-18

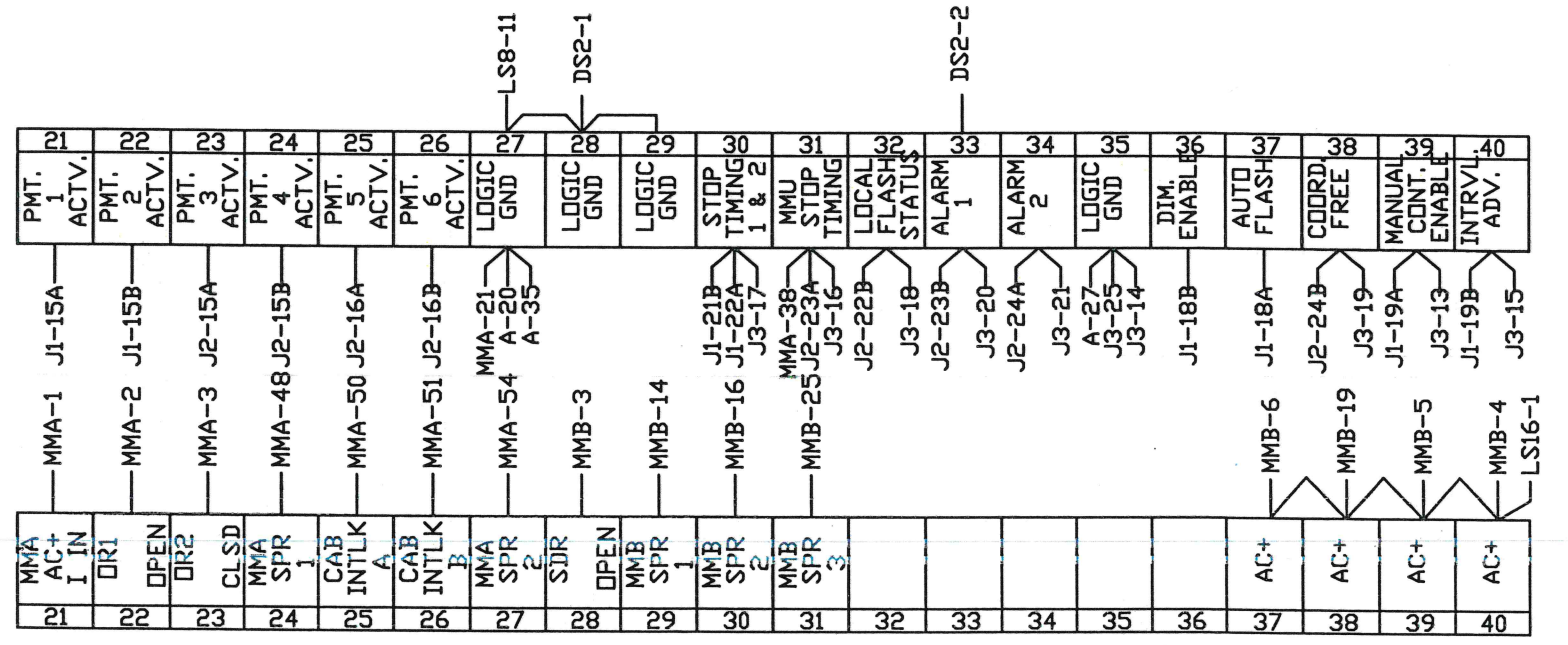

INTERFACE TERMINAL BLOCKS

J1 BIU #1			J2 BIU #2		
PIN	FUNCTION	TO	PIN	FUNCTION	TO
1A	+24 VDC	K1-11	1A	+24 VDC	J2-1B
1B	+24 VDC	J2-1B	1B	+24 VDC	J1-1B
2A	LS1 RED	LS1-6	2A	LS9 RED	LS9-6
2B	LS1 YELLOW	LS1-8	2B	LS9 YELLOW	LS9-8
3A	LS1 GREEN	LS1-10	3A	LS9 GREEN	LS9-10
3B	LS2 RED	LS2-6	3B	LS10 RED	LS10-6
4A	LS2 YELLOW	LS2-8	4A	LS10 YELLOW	LS10-8
4B	LS2 GREEN	LS2-10	4B	LS10 GREEN	LS10-10
5A	LS3 RED	LS3-6	5A	LS11 RED	LS11-6
5B	LS3 YELLOW	LS3-8	5B	LS11 YELLOW	LS11-8
6A	LS3 GREEN	LS3-10	6A	LS11 GREEN	LS11-10
6B	LS4 RED	LS4-6	6B	LS12 RED	LS12-6
7A	LS4 YELLOW	LS4-8	7A	LS12 YELLOW	LS12-8
7B	LS4 GREEN	LS4-10	7B	LS12 GREEN	LS12-10
8A	LS5 RED	LS5-6	8A	LS13 RED	LS13-6
8B	LS5 YELLOW	LS5-8	8B	LS13 YELLOW	LS13-8
9A	LS5 GREEN	LS5-10	9A	LS13 GREEN	LS13-10
9B	LS6 RED	LS6-6	9B	LS14 RED	LS14-6
10A	LS6 YELLOW	LS6-8	10A	LS14 YELLOW	LS14-8
10B	LS6 GREEN	LS6-10	10B	LS14 GREEN	LS14-10
11A	LS7 RED	LS7-6	11A	LS15 RED	LS15-6
11B	LS7 YELLOW	LS7-8	11B	LS15 YELLOW	LS15-8
12A	LS7 GREEN	LS7-10	12A	LS15 GREEN	LS15-10
12B	LS8 RED	LS8-6	12B	LS16 RED	LS16-6
13A	LS8 YELLOW	LS8-8	13A	LS16 YELLOW	LS16-8
13B	LS8 GREEN	LS8-10	13B	LS16 GREEN	LS16-10
14A	TBC AUX 1	A-16	14A	TBC AUX 3	A-18
14B	TBC AUX 2	A-17	14B	COORD. STATUS	A-19
15A	PMT ACT 1	A-21	15A	PMT ACT 3	A-23
15B	PMT ACT 2	A-22	15B	PMT ACT 4	A-24
16A	PMT CALL 1	B-15	16A	PMT ACT 5	A-25
16B	PMT CALL 2	B-16	16B	PMT ACT 6	A-26
17A	TEST A	A-12	17A	PMT CALL 3	B-17
17B	TEST B	A-13	17B	PMT CALL 4	B-18
18A	AUTO FLASH	A-37	18A	PMT CALL 5	B-19
18B	DIM. ENABLE	A-36	18B	PMT CALL 6	B-20
19A	MANUAL CONT.	A-39	19A	CNA 2	A-8
19B	INT. ADVANCE	A-40	19B	SPARE 1	B-10
20A	EXT. MIN. RECALL	A-10	20A	SPARE 2	B-11
20B	EXT. START	A-11	20B	SPARE 3	B-12
21A	TBC ONLINE	A-15	21A	SPARE 4	B-13
21B	STOP TIME (1)	A-30	21B	INHIBIT MAX (1)	A-1
22A	STOP TIME (2)	A-30	22A	INHIBIT MAX (2)	A-2
22B	MAX. 2 (1)	A-5	22B	LOCAL FLASH	A-32
23A	MAX. 2 (2)	A-6	23A	MMU FLASH	A-31
23B	FORCE OFF (1)	A-3	23B	ALARM 1	A-33
24A	FORCE OFF (2)	A-4	24A	ALARM 2	A-34
24B	CNA 1	A-7	24B	COORD FREE IN	A-38
25A	WALK REST MOD.	A-9	25A	TEST C	A-14
25B	PED. ISO. 1	B-6	25B	PED. ISO. 5	B-8
26A	PED. ISO. 2	PC2-A	26A	PED. ISO. 6	PC6-A
26B	PED. ISO. 3	B-7	26B	PED. ISO. 7	B-9
27A	PED. ISO. 4	PC4-A	27A	PED. ISO. 8	PC8-A
27B	PED. ISO. COMN.	J3-31	27B	PED. ISO. COMN.	J1-27B
28A	ADDR. SEL. 0	-----	28A	ADDR. SEL. 0	J2-32A
28B	ADDR. SEL. 1	-----	28B	ADDR. SEL. 1	-----
29A	ADDR. SEL. 2	-----	29A	ADDR. SEL. 2	-----
29B	ADDR. SEL. 3	-----	29B	ADDR. SEL. 3	-----
30A	RESERVED	-----	30A	RESERVED	-----
30B	RESERVED	-----	30B	RESERVED	-----
31A	EARTH GND.	LS12-2	31A	EARTH GND.	J1-31A
31B	LINE FREQ. REF.	J3-29	31B	LINE FREQ. REF.	J1-31B
32A	LOGIC GND.	B-14	32A	LOGIC GND.	J1-32B
32B	LOGIC GND.	J2-32A	32B	LOGIC GND.	J2-32A

MAIN PANEL CONTROL POWER C/C 34842G4	
PIN	FUNCTION
1	LOGIC GND
2	+24 VDC (IN)
3	-----
4	MMU FAULT MONITOR (IN)
5	LINE FREQ. REFERENCE (IN)
6	-----
7	+12 VAC (IN)
8	SIGNAL BUS CONTROL (IN)
9	-----
10	FILTERED AC NEUTRAL (IN)
11	CONT. EQUIP. AC LINE (OUT)
12	FILTERED AC LINE (IN)

CONTROLLER POWER (CCA2) C/C 34842G3			
WIRE	PIN	SIGNAL	TO
1	A	FAULT MONITOR	PB-4
2	U	AC NEUTRAL	PB-10
3	V	EARTH GROUND	PB-9
4	W	LOGIC GROUND	PB-1
5	P	AC LINE	PB-11
6	SHL	EARTH GND.	CCA2-V

TYPE 1 CONTROLLER POWER C/C 34842G2		
PIN	FUNCTION	TO
A	AC NEUTRAL	PB-10
B	-----	-----
C	AC LINE	PB-11
D	+12 VDC	-----
E	+24 VDC	-----
F	RESERVED	-----
G	FAULT MON.	PB-4
H	LOGIC GND.	PB-1
I	EARTH GND.	PB-9
J	+12 VAC	-----
K	RESERVED	-----
L	-----	-----
SHL	EARTH GND.	PIN H

CABINET POWER SUPPLY C/C 34842G1		
PIN	FUNCTION	TO
A	AC NEUTRAL	PB-10
B	LINE FREQUENCY REF.	PB-5
C	AC LINE	PB-11
D	+12 VDC	PB-3
E	+24 VDC	PB-2
F	RESERVED	-----
G	LOGIC GND.	PB-1
H	EARTH GND.	PB-9
I	+12 VAC	PB-7
J	RESERVED	-----
SHL	EARTH GND.	PIN H

CONTROLLER PORT 1 CONNECTOR			
PIN	SIGNAL	TO	FUNCTION
1	TWISTED PAIR 1+	SDLC-1	CONT TXD+
2	LOGIC GND.	-----	-----
3	TWISTED PAIR 2+	SDLC-4	CONT TXC+
4	LOGIC GND.	-----	-----
5	TWISTED PAIR 3+	SDLC-7	CONT RXD+
6	LOGIC GND.	-----	-----
7	TWISTED PAIR 4+	SDLC-10	CONT RXC+
8	LOGIC GND.	-----	-----
9	TWISTED PAIR 1-	SDLC-2	CONT TXD-
10	PORT 1 DISABLE	-----	-----
11	TWISTED PAIR 2-	SDLC-5	CONT TXC-
12	EARTH GND.	SHIELD WIRE	-----
13	TWISTED PAIR 3-	SDLC-8	CONT RXD-
14	RESERVED	-----	-----
15	TWISTED PAIR 4-	SDLC-11	CONT RXC-

MMU & BIU PORT 1 CONNECTOR			
PIN	SIGNAL	TO	FUNCTION
1	TWISTED PAIR 1+	SDLC-1	BIU RXD+
2	LOGIC GND.	-----	-----
3	TWISTED PAIR 2+	SDLC-4	BIU RXC+
4	LOGIC GND.	-----	-----
5	TWISTED PAIR 3+	SDLC-7	BIU TXD+
6	LOGIC GND.	-----	-----
7	TWISTED PAIR 4+	SDLC-10	BIU TXC+
8	LOGIC GND.	-----	-----
9	TWISTED PAIR 1-	SDLC-2	BIU RXD-
10	PORT 1 DISABLE	-----	-----
11	TWISTED PAIR 2-	SDLC-5	BIU RXC-
12	EARTH GND.	SHIELD WIRE	-----
13	TWISTED PAIR 3-	SDLC-8	BIU TXD-
14	RESERVED	-----	-----
15	TWISTED PAIR 4-	SDLC-11	BIU TXC-

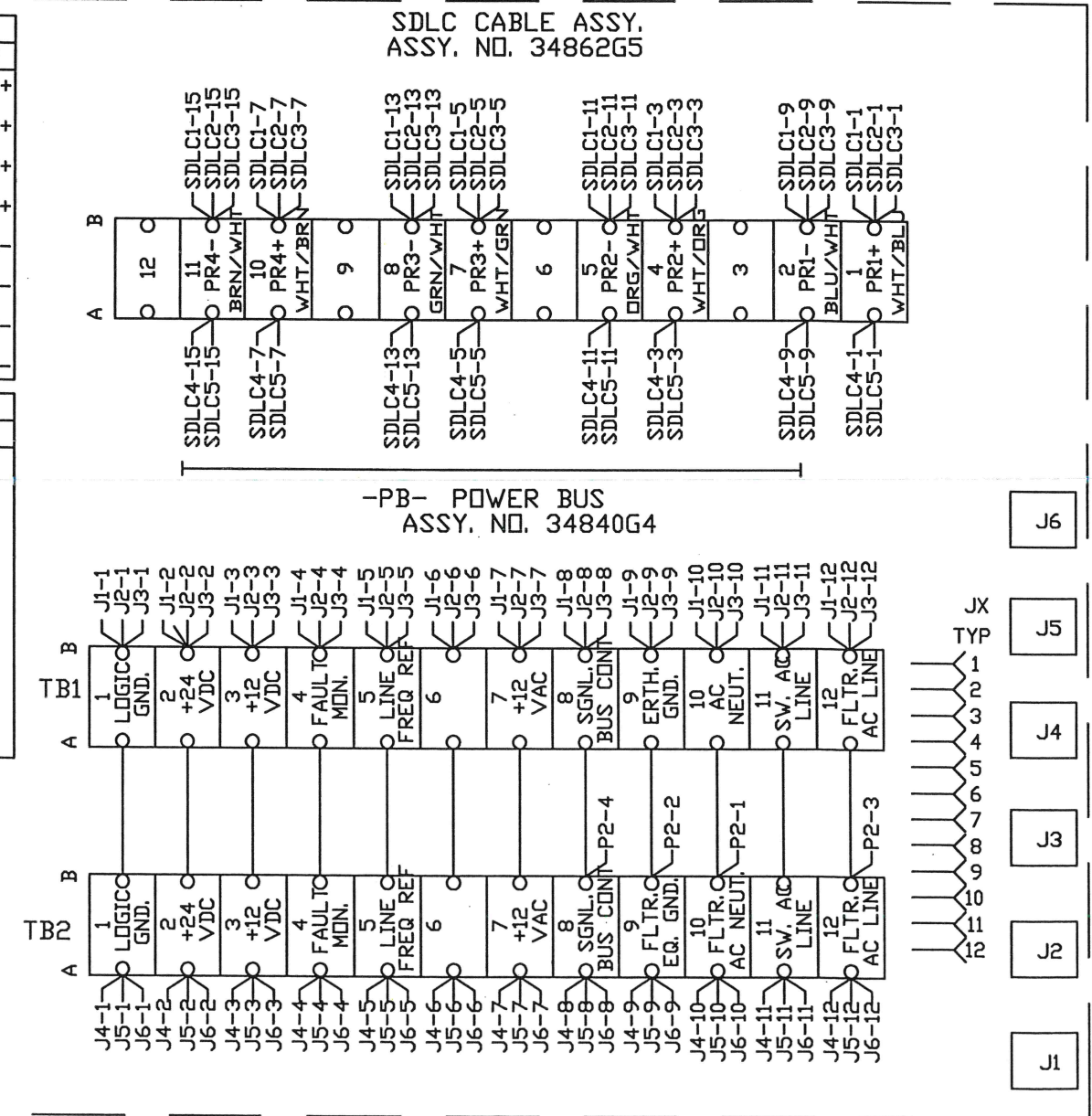
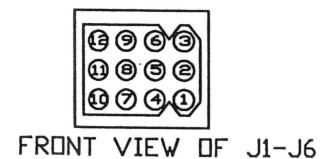
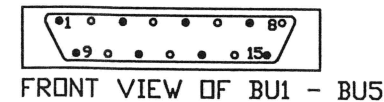

BIU AND CONNECTING CABLES

# WIRE LIST FOR NEMA MALFUNCTION MANAGEMENT UNIT

CONNECTOR "A" (MMA)				CONNECTOR "B" (MMB)								
PIN	WIRE	MON. FUNCTION	SIG. FUNCTION	PIN	WIRE	MON. FUNCTION	SIG. FUNCTION					
A	A-1	AC+ I INPUT	B21	A	B-1	AC+ II INPUT	J3-2	MMU POWER				
B	A-2	OUT RLY 1 OPEN	B22	B	B-2	S. DLY RLY COMM.	J3-6	MMU POWER				
C	A-3	OUT RLY 2 CLSD	B23	C	B-3	S. DLY RLY OPEN	B28					
D	A-4	CH. 12 GREEN	12G-A	D	B-4	CH. 12 RED	B40					
E	A-5	CH. 11 GREEN	11G-A	E	B-5	CH. 11 RED	B39					
F	A-6	CH. 10 GREEN	10G-A	F	B-6	CH. 9 RED	B37					
G	A-7	CH. 9 GREEN	9G-A	G	B-7	CH. 8 RED	8R-A	^8 RED				
H	A-8	CH. 8 GREEN	8G-A	H	B-8	CH. 7 RED	7R-A	^7 RED				
J	A-9	CH. 7 GREEN	7G-A	J	B-9	CH. 6 RED	6R-A	^6 RED				
K	A-10	CH. 6 GREEN	6G-A	K	B-10	CH. 5 RED	5R-A	^5 RED				
L	A-11	CH. 5 GREEN	5G-A	L	B-11	CH. 4 RED	4R-A	^4 RED				
M	A-12	CH. 4 GREEN	4G-A	M	B-12	CH. 2 RED	2R-A	^2 RED				
N	A-13	CH. 3 GREEN	3G-A	N	B-13	CH. 1 RED	1R-A	^1 RED				
P	A-14	CH. 2 GREEN	2G-A	P	B-14	(SPARE 1)	B29					
R	A-15	CH. 1 GREEN	1G-A	R	B-15	+24V MONITOR II	B-3	+24V MON. II				
S	A-16	+24V MON. I	B-4	S	B-16	(SPARE 2)	B30					
T	A-17	LOGIC GND	B-14	T	B-17	CH. 13 RED	13R-A	DLA RED				
U	A-18	CHASSIS GND	LS7-2	U	B-18	S. DLY RLY CLSD	J3-35	CONT. POWER				
V	A-19	AC- (COMMON)	K1-2	V	B-19	CH. 10 RED	B38					
W	A-20	OUT RLY 1 COM.	J3-7	W	B-20	CH. 14 RED	14R-A	DLB RED				
X	A-21	OUT RLY 2 COM.	A-27	X	B-21	CH. 15 RED	15R-A	DLC RED				
Y	A-22	CH. 12 YELLOW	-T-	Y	B-22	CH. 16 RED	16R-A	OLD RED				
Z	A-23	CH. 11 YELLOW	-T-	Z	B-23	CH. 3 RED	3R-A	^3 RED				
a	A-24	CH. 10 WALK	----	a	B-24	RED ENABLE	LS8-1	SIG BUS CON.				
b	A-25	CH. 10 YELLOW	-T-	b	B-25	(SPARE 3)	B31					
c	A-26	CH. 9 YELLOW	-T-	c	B-26	LOCAL FLASH IN	CAPPED	POL/AX FLSH				
d	A-27	CH. 8 YELLOW	8Y-A		B-27	SHELL GROUND	LS6-2	EARTH GND.				
e	A-28	CH. 7 YELLOW	7Y-A	<b>NOTES FOR 16 CHANNEL M.M.U.</b> (1) RELAY CONTACT POSITIONS SPECIFIED ARE FOR NON-CONFLICT MODE. (2) TO PROGRAM MMU, SOLDER JUMPERS IN PROGRAMMING CARD FOR ALL PERMISSABLE PHASE MOVEMENTS, MINIMUM CHANGE DIS-ABLE FOR ALL PEDESTRIAN CHANNELS, AND MIN. FLASH, VOLTAGE MON., AND 24V. MON. LATCH OPTIONS AS DESIRED.  <b>M.M.U. CHANNEL ASSIGNMENTS</b> CH. 1 = L/S 1 = ^1 VEH. CH. 2 = L/S 2 = ^2 VEH. CH. 3 = L/S 3 = ^3 VEH. CH. 4 = L/S 4 = ^4 VEH. CH. 5 = L/S 5 = ^5 VEH. CH. 6 = L/S 6 = ^6 VEH. CH. 7 = L/S 7 = ^7 VEH. CH. 8 = L/S 8 = ^8 VEH. CH. 9 = L/S 9 = ^2 PED. CH. 10 = L/S 10 = ^4 PED. CH. 11 = L/S 11 = ^6 PED. CH. 12 = L/S 12 = ^8 PED. CH. 13 = L/S 13 = DLAP A CH. 14 = L/S 14 = DLAP B CH. 15 = L/S 15 = DLAP C CH. 16 = L/S 16 = DLAP D								
f	A-29	CH. 6 YELLOW	6Y-A									
g	A-30	CH. 5 YELLOW	5Y-A									
h	A-31	CH. 3 YELLOW	3Y-A									
i	A-32	CH. 15 GREEN	15G-A									
j	A-33	CH. 2 YELLOW	2Y-A									
k	A-34	CH. 1 YELLOW	1Y-A									
m	A-35	CONT. VOLT. MON.	B-5									
n	A-36	+24V MON. INH.	B-2									
p	A-37	OUT RLY 1 CLSD	J3-3									
q	A-38	OUT RLY 2 OPEN	A-31									
r	A-39	CH. 12 WALK	----									
s	A-40	CH. 11 WALK	----									
t	A-41	CH. 9 WALK	----									
u	A-42	CH. 16 YELLOW	16Y-A									
v	A-43	CH. 15 YELLOW	15Y-A									
w	A-44	CH. 13 YELLOW	13Y-A									
x	A-45	CH. 4 YELLOW	4Y-A									
y	A-46	CH. 14 GREEN	14G-A									
z	A-47	CH. 13 GREEN	13G-A									
AA	A-48	(SPARE 1)	B24									
BB	A-49	RESET	B-1									
CC	A-50	CAB. INTLK A	B25									
DD	A-51	CAB. INTLK B	B26									
EE	A-52	CH. 14 YELLOW	14Y-A									
FF	A-53	CH. 16 GREEN	16G-A									
GG	A-54	(SPARE 2)	B27									
HH	A-55	TYPE SELECT	A-20									
	A-56	SHELL GND	LS15-2									

## MMU PROGRAM CARD

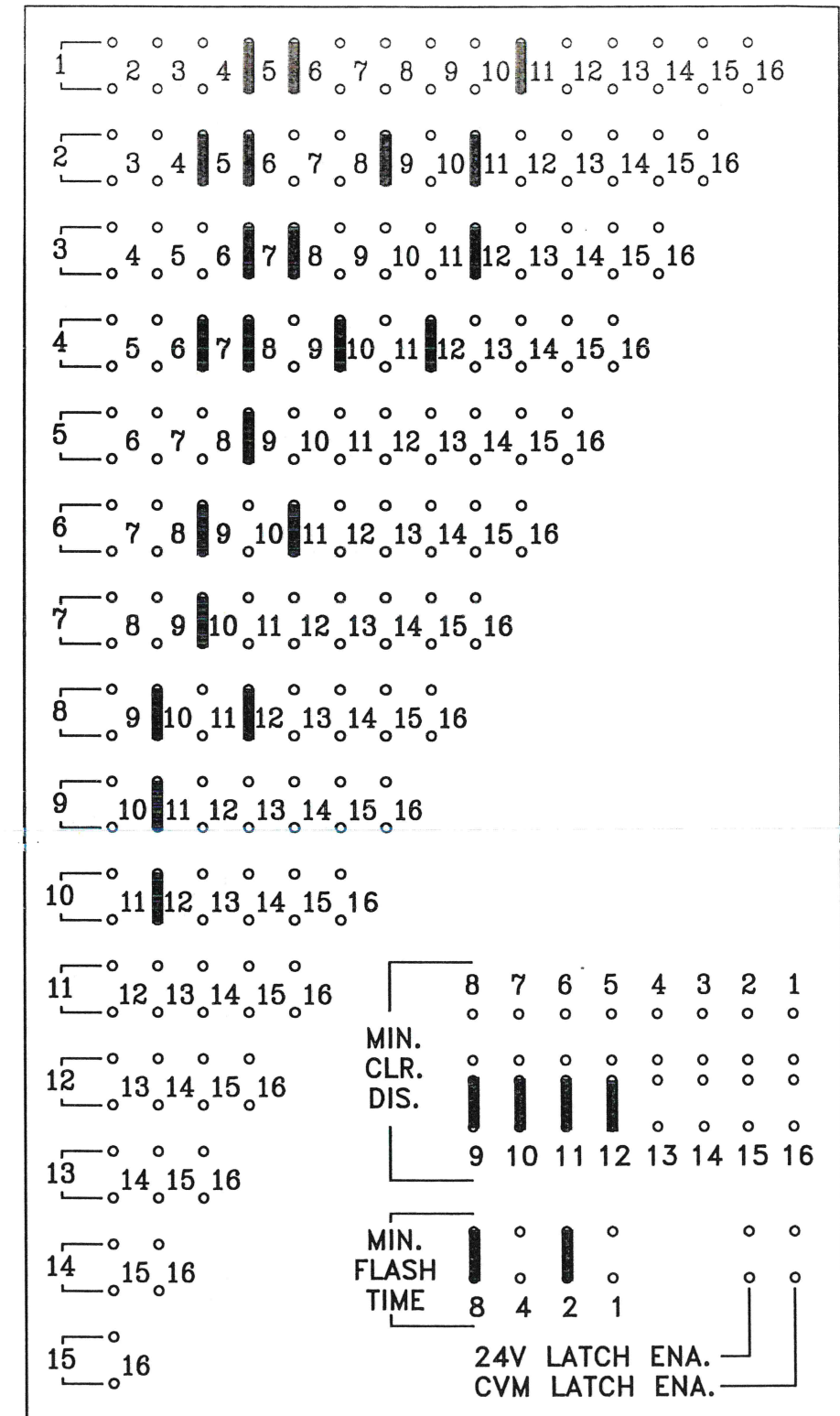

## M.M.U. C/C'S AND PROGRAM CARD

# DETECTOR RACK 34030G1

POWER SUPPLY OR B.I.U.	L3	L1	L7	L5	L11	L9	L15	L13	PMT 5	PMT 3	PGM. CARD
	1-3	1-1	5-3	5-1	2-3	2-1	6-3	6-1	3-8	1-6	
	<input type="checkbox"/> 2CH 1-4	<input type="checkbox"/> 2CH 1-2	<input type="checkbox"/> 2CH 5-4	<input type="checkbox"/> 2CH 5-2	<input type="checkbox"/> 2CH 2-4	<input type="checkbox"/> 2CH 2-2	<input type="checkbox"/> 2CH 6-4	<input type="checkbox"/> 2CH 6-2	<input type="checkbox"/> 2CH OPTICOM/ OPIC CH. C CH. D	<input type="checkbox"/> 4CH <input type="checkbox"/> 2CH OPTICOM/ OPIC CH. A CH. B	
	L4	L2	L8	L6	L12	L10	L16	L14	PMT 6	PMT 4	

J13 C/C 33284G10 DC POWER	J16 C/C 33284G8 EXP. OUTPUTS	J14 C/C 33284G2 LPS 1-8	J18 C/C 33284G9 SYS. OUTPUTS	J15 C/C 33284G3 LPS 9-16	J17 C/C 33284G6 AC POWER	J19 C/C 33284G17 PGM. CARD
---------------------------------	------------------------------------	-------------------------------	------------------------------------	--------------------------------	--------------------------------	----------------------------------

①

ADDRESS TABLE					
RACK #	JMPR	DET. #'S	RACK #	JMPR	DET. #'S
1		1-16	5		65-80
2		17-32	6		81-96
3		33-48	7		97-112
4		49-64	8		113-128

DETECTOR ASSIGNMENTS		
CONT. INPUT	PHASE ASGN.	DETECTOR TYPE
1	1-1	1
2	1-2	1
3	1-3	1
4	1-4	1
5	5-1	1
6	5-2	1
7	5-3	1
8	5-4	1
9	2-1	1
10	2-2	1
11	2-3	1
12	2-4	1
13	6-1	1
14	6-2	1
15	6-3	1
16	6-4	1
17	3-1	1
18	3-2	1
19	3-3	1
20	3-4	1
21	7-1	1
22	7-2	1
23	7-3	1
24	7-4	1
25	4-1	1
26	4-2	1
26	4-3	1
28	4-4	1
29	8-1	1
30	8-2	1
31	8-3	1
32	8-4	1
33		
34		
35		
36		

## DETECTOR LAYOUT

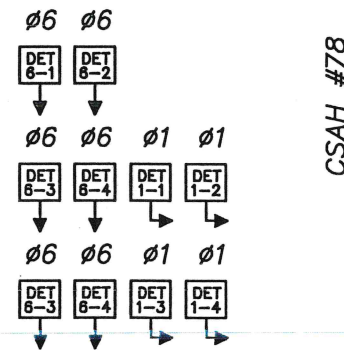

TH 242

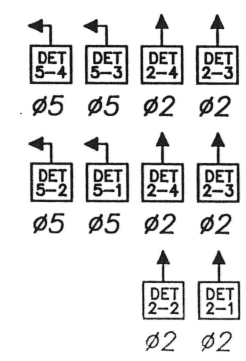
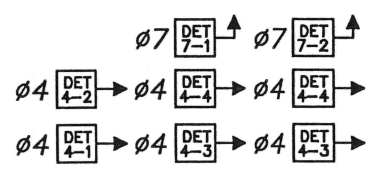
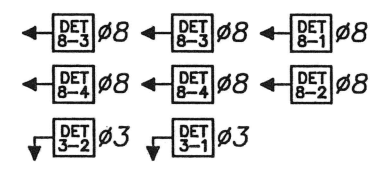

DETECTOR RACK PROGRAMMING JUMPERS																														
DET. TYPE	SLOT 1/2 ①      SLOT 3/4 ①      SLOT 5/6 ①      SLOT 7/8 ①																													
	JP1	JP2	JP3	JP4	JP5	JP6	JP7	JP8	JP9	JP10	JP11	JP12	JP13	JP14	JP15	JP16	JP17	JP18	JP19	JP20	JP21	JP22	JP23	JP24	JP25	JP26	JP27	JP28	JP29	JP30
① TS-1	NO	NO																												
② TS-2	YES	YES																												
③ LM-632T 262-FC	NO	NO																												
④ MAG.	NO	NO																												

DETECTOR LOOP  
INTERFACE  
ASSY. 34040G1

J1  
TO DR1: J14  
C/C 33284G2

J2  
TO DR1: J15  
C/C 33284G3

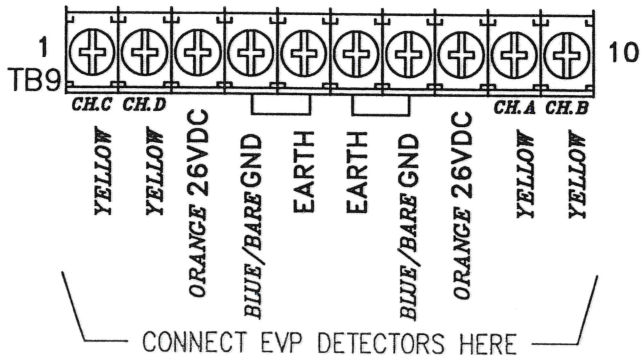
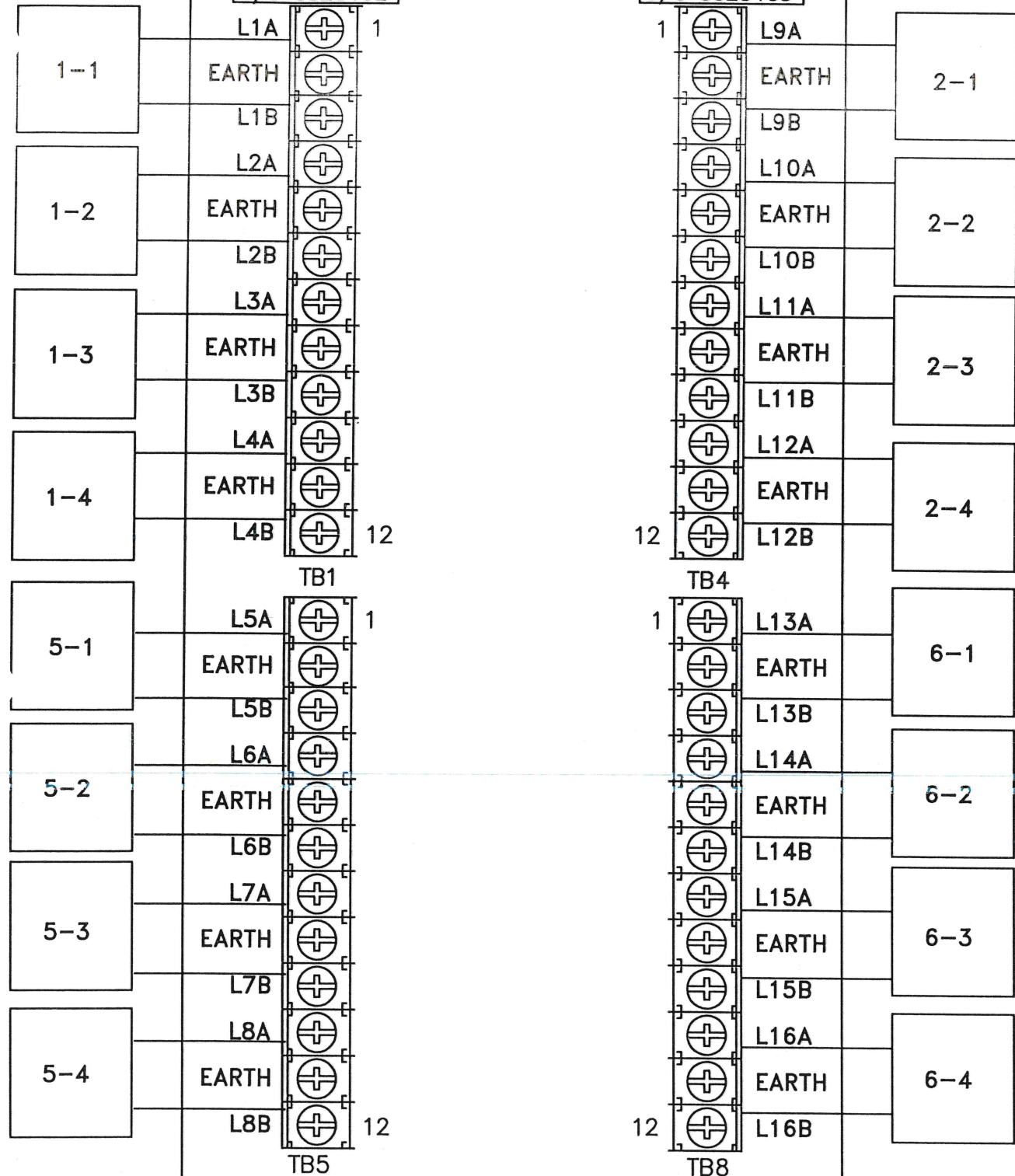

DET. LOOPS 9-16 (J15) C/C 33284G3

PIN	SIGNAL	TO
1	LOOP 9+	LPI2: TB4-1
2	LOOP 9-	LPI2: TB4-3
3	LOOP 10+	LPI2: TB4-4
4	LOOP 10-	LPI2: TB4-6
5	LOOP 11+	LPI2: TB4-7
6	LOOP 11-	LPI2: TB4-9
7	LOOP 12+	LPI2: TB4-10
8	LOOP 12-	LPI2: TB4-12
9	LOOP 13+	LPI2: TB8-1
10	LOOP 13-	LPI2: TB8-3
11	LOOP 14+	LPI2: TB8-4
12	LOOP 14-	LPI2: TB8-6
13	LOOP 15+	LPI2: TB8-7
14	LOOP 15-	LPI2: TB8-9
15	LOOP 16+	LPI2: TB8-10
16	LOOP 16-	LPI2: TB8-12
17	----	
18	----	
19	----	
20	----	

DET. LOOPS 1-8 (J14) C/C 33284G2

PIN	SIGNAL	TO
1	LOOP 1+	LPI1: TB1-1
2	LOOP 1-	LPI1: TB1-3
3	LOOP 2+	LPI1: TB1-4
4	LOOP 2-	LPI1: TB1-6
5	LOOP 3+	LPI1: TB1-7
6	LOOP 3-	LPI1: TB1-9
7	LOOP 4+	LPI1: TB1-10
8	LOOP 4-	LPI1: TB1-12
9	LOOP 5+	LPI1: TB5-1
10	LOOP 5-	LPI1: TB5-3
11	LOOP 6+	LPI1: TB5-4
12	LOOP 6-	LPI1: TB5-6
13	LOOP 7+	LPI1: TB5-7
14	LOOP 7-	LPI1: TB5-9
15	LOOP 8+	LPI1: TB5-10
16	LOOP 8-	LPI1: TB5-12
17	PMT. DET. CH. C	LPI1: TB9-1
18	PMT. DET. CH. D	LPI1: TB9-2
19	KEY PIN	
20	PMT. CH. C/D +26VDC	LPI1: TB9-3
21	PMT. DC GROUND	LPI1: TB9-4,7
22	PMT. CH. A/B +26VDC	LPI1: TB9-8
23	PMT. DET. CH. A	LPI1: TB9-9
24	PMT. DET. CH. B	LPI1: TB9-10
25	----	
26	----	

DET. RACK POWER C/C 34842G5			
P1/ DR: J13	P2/ DR: J17	FUNCTION	TO
1		+12 VDC (DET. POWER)	PB-3
2		+24 VDC (BIU POWER)	PB-2
3		LOGIC GROUND	PB-1
4		EARTH GROUND	PB-9
5		"KEY PIN"	
6		LINE FREQUENCY REF.	PB-5
	1	EARTH GROUND	----
	2	AC LINE	PB-12
	3	AC NEUTRAL	PB-10
	4	LOGIC GROUND	----

EXPANSION OUTPUTS C/C 33284G8		
J16	FUNCTION	TO
17	DET. 17 / PMT. A OUT	MP: B19
18	DET. 18 / PMT. B OUT	MP: B20
19	PMT. C OUT	MP: B17
20	PMT. D OUT	MP: B18

DETECTOR LOOP INTERFACE



DETECTOR LOOP  
INTERFACE  
ASSY. 34040G1

J1  
TO DR1:J14  
C/C 33284G2

J2  
TO DR1:J15  
C/C 33284G3

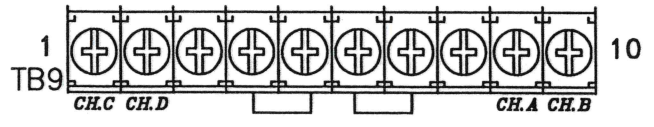
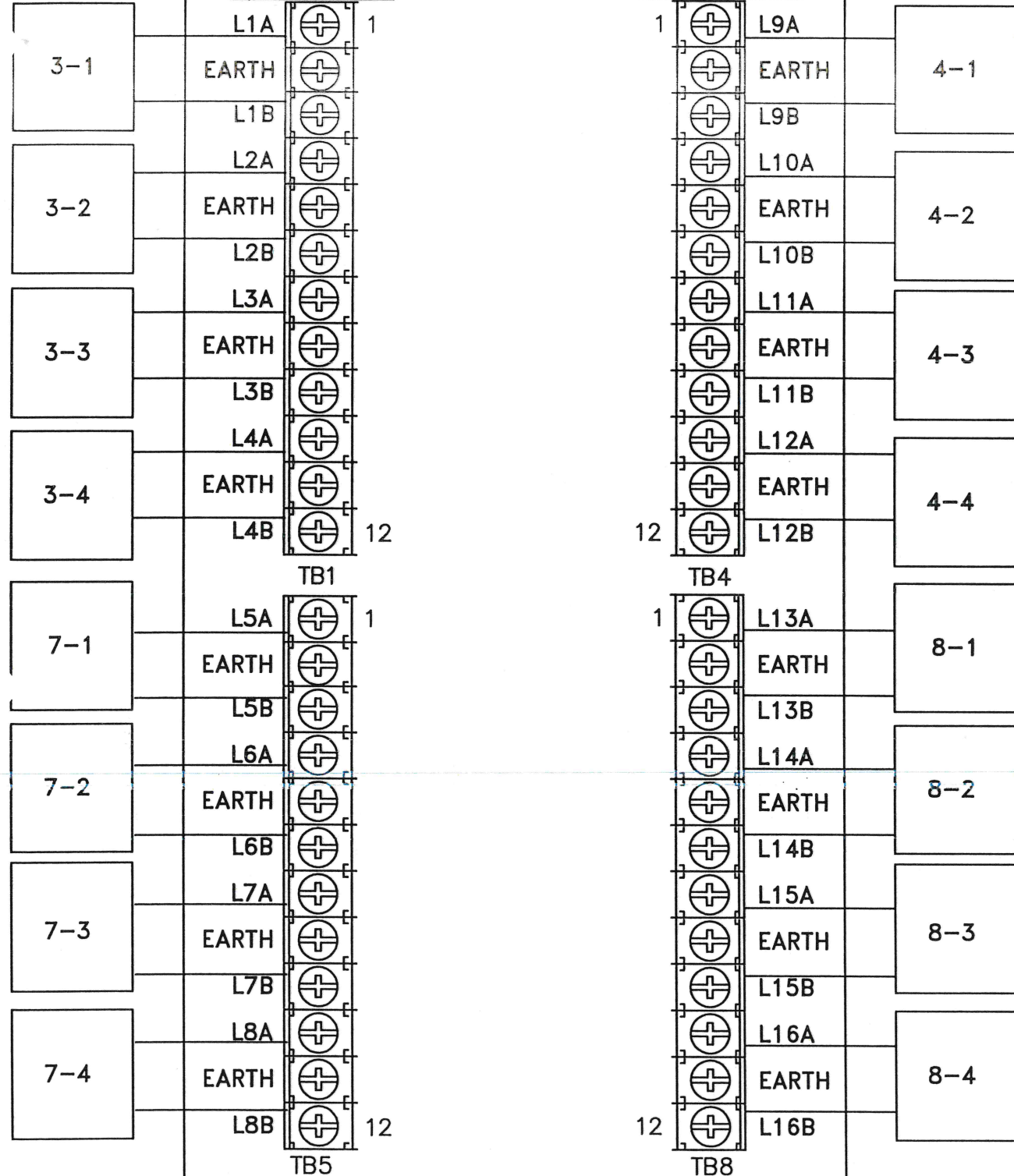

DET. LOOPS 9-16 (J15) C/C 33284G3

PIN	SIGNAL	TO
1	LOOP 9+	LPI2: TB4-1
2	LOOP 9-	LPI2: TB4-3
3	LOOP 10+	LPI2: TB4-4
4	LOOP 10-	LPI2: TB4-6
5	LOOP 11+	LPI2: TB4-7
6	LOOP 11-	LPI2: TB4-9
7	LOOP 12+	LPI2: TB4-10
8	LOOP 12-	LPI2: TB4-12
9	LOOP 13+	LPI2: TB8-1
10	LOOP 13-	LPI2: TB8-3
11	LOOP 14+	LPI2: TB8-4
12	LOOP 14-	LPI2: TB8-6
13	LOOP 15+	LPI2: TB8-7
14	LOOP 15-	LPI2: TB8-9
15	LOOP 16+	LPI2: TB8-10
16	LOOP 16-	LPI2: TB8-12
17	----	
18	----	
19	----	
20	----	

DET. LOOPS 1-8 (J14) C/C 33284G2

PIN	SIGNAL	TO
1	LOOP 1+	LPI1: TB1-1
2	LOOP 1-	LPI1: TB1-3
3	LOOP 2+	LPI1: TB1-4
4	LOOP 2-	LPI1: TB1-6
5	LOOP 3+	LPI1: TB1-7
6	LOOP 3-	LPI1: TB1-9
7	LOOP 4+	LPI1: TB1-10
8	LOOP 4-	LPI1: TB1-12
9	LOOP 5+	LPI1: TB5-1
10	LOOP 5-	LPI1: TB5-3
11	LOOP 6+	LPI1: TB5-4
12	LOOP 6-	LPI1: TB5-6
13	LOOP 7+	LPI1: TB5-7
14	LOOP 7-	LPI1: TB5-9
15	LOOP 8+	LPI1: TB5-10
16	LOOP 8-	LPI1: TB5-12
17	PMT. DET. CH. C	LPI1: TB9-1
18	PMT. DET. CH. D	LPI1: TB9-2
19	KEY PIN	
20	PMT. CH. C/D +26VDC	LPI1: TB9-3
21	PMT. DC GROUND	LPI1: TB9-4,7
22	PMT. CH. A/B +26VDC	LPI1: TB9-8
23	PMT. DET. CH. A	LPI1: TB9-9
24	PMT. DET. CH. B	LPI1: TB9-10
25	----	
26	----	

DET. RACK POWER C/C 34842G5			
P1/ DR: J13	P2/ DR: J17	FUNCTION	TO
1		+12 VDC (DET. POWER)	PB-3
2		+24 VDC (BIU POWER)	PB-2
3		LOGIC GROUND	PB-1
4		EARTH GROUND	PB-9
5		"KEY PIN"	
6		LINE FREQUENCY REF.	PB-5
	1	EARTH GROUND	----
	2	AC LINE	PB-12
	3	AC NEUTRAL	PB-10
	4	LOGIC GROUND	----

EXPANSION OUTPUTS C/C 33284G8		
J16	FUNCTION	TO
17	DET. 17 / PMT. A OUT	MP: B19
18	DET. 18 / PMT. B OUT	MP: B20
19	PMT. C OUT	MP: B17
20	PMT. D OUT	MP: B18

DETECTOR LOOP INTERFACE

**EVP SENSORS**

CABLE	DISCR. CHAN.	PHASES	POLE#	TERMINAL TB9		
				SIGNAL	DC(+)	GND
54	1	1-6	4	9	8	7
20	2	2-5	2	10	8	7
40	3	3-8	1	1	3	4
34	4	4-7	3	2	3	4

**VEHICLE SIGNALS**

CABLE	SIGNAL	TERMINAL					
		G	Y	R	G	Y	R
51	1-1	1	3	5			
31	1-2	2	4	6			
15	2-1,2-3				7	9	11
16	2-2				8	10	12
37	3-1	13	15	17			
51	3-2	14	16	18			
29	4-1,4-3				19	21	23
30	4-2				20	22	24
17	5-1	25	27	29			
37	5-2	26	28	30			
49	6-1,6-3				31	33	35
50	6-2				32	34	36
31	7-1	37	39	41			
17	7-2	38	40	42			
35	8-1,8-3				43	45	47
36	8-2				44	46	48

**VEH DETECTORS**

CABLE	DET	SLOT	FUNC	RACK	TERMINAL
11	1-1	1	1	1	L1
12	1-2	2	1	1	L2
13	1-3	3	1	1	L3
14	1-4	4	1	1	L4
61	2-1	9	1	1	L9
62	2-2	10	1	1	L10
59	2-3	11	2	1	L11
60	2-4	12	2	1	L12
25	3-1	17	1	2	L1
26	3-2	18	1	2	L2
27	3-3	19	1	2	L3
28	3-4	20	1	2	L4
47	4-1	25	1	2	L9
48	4-2	26	1	2	L10
45	4-3	27	2	2	L11
46	4-4	28	2	2	L12
55	5-1	5	1	1	L5
56	5-2	6	1	1	L6
57	5-3	7	1	1	L7
58	5-4	8	1	1	L8
9	6-1	13	1	1	L13
10	6-2	14	1	1	L14
7	6-3	15	2	1	L15
8	6-4	16	2	1	L16
41	7-1	21	1	2	L5
42	7-2	22	1	2	L6
43	7-3	23	1	2	L7
44	7-4	24	1	2	L8
23	8-1	29	1	2	L13
24	8-2	30	1	2	L14
21	8-3	31	2	2	L15
22	8-4	32	2	2	L16

**PED PUSHBUTTONS**

CABLE	PPB	TERMINAL	RETURN
32	2-1	PC2	GB1
18	2-2	PC2	GB1
52	4-1	PC4	GB1
32	4-2	PC4	GB1
38	6-1	PC6	GB1
52	6-2	PC6	GB1
18	8-1	PC8	GB1
38	8-2	PC8	GB1

**PED SIGNALS**

CABLE	SIGNAL	TERMINAL	
		WK	DW
30	2-1	49	53
16	2-2	50	54
50	4-1	55	59
30	4-2	56	60
36	6-1	61	65
50	6-2	62	66
16	8-1	67	71
36	8-2	68	72

**EVP VERIFY LIGHTS**

CABLE	CONTR. CHAN.	PHASES	POLE#	TERM.
53	3	1-6	4	51
19	4	2-5	2	57
39	5	3-8	1	63
33	6	4-7	3	69