

MAIN PANEL:171-1081-504

ASC3-2100 CONTROLLER WITH:	LEGEND
<ul style="list-style-type: none"> ■ CONFIGURATION: 3601 ■ SOFTWARE: 2.44.30 ■ ETHERNET MODULE 	<ul style="list-style-type: none"> BIU BUS INTERFACE UNIT BU() C/C, BIU () CB() CIRCUIT BREAKER () C/C CONNECTING CABLE CCA CONTROLLER CABLE "A" CDP C/C, DR POWER CMA MMU/CMU CABLE "A" CMB MMU/CMU CABLE "B" CPO C/C PRE-EMPT OUTPUTS CPP C/C PRE-EMPT POWER DR DETECTOR RACK DS() DOOR SWITCH () FL() FLASHER () FR() FLASH XFER. RELAY LS() LOAD SWITCH MC MERCURY CONTACTOR MP MAIN PANEL PAP POWER-AUX PANEL PSP CAB. PWR. SUPPLY SA SURGE ARRESTOR TB-() TERM. BLOCK ()
<ul style="list-style-type: none"> □ OVERLAPS <ul style="list-style-type: none"> □ IN EEPROM □ KEYBOARD ENTERED □ ANALOG TELEMETRY MOD.: 100-1005-501 ■ INTERNAL RS-232 TELEMETRY □ TEST INPUT A = □ TEST INPUT B = 	

FLASHER	
PIN	FUNCTION
7	CIRCUIT #1
8	CIRCUIT #2
9	CHASSIS GND
10	AC COMMON
11	115 VAC
12	-----

LOAD SWITCH	
PIN	FUNCTION
1	115 VAC
2	CHASSIS GND
3	RED/DW OUTPUT
4	-----
5	YEL OUTPUT
6	RED/DW INPUT
7	GRN/W OUTPUT
8	YEL INPUT
9	+24 VDC
10	GRN/W INPUT
11	AC COMMON
12	-----

①
2.2K
10W

3 USE ONLY COPPER CONDUCTORS FOR FIELD AND SERVICE CONNECTIONS.

2 CONNECT A.C. SERVICE TO TERMINAL BLOCK 501 (LINE), 502 (NEUTRAL) AND GB2 (EARTH) ON RIGHT SIDEWALL OF CABINET.

①INSTALL 2.2K, 10 WATT LOAD RESISTORS BETWEEN PINS 7 AND 11 ON LOAD SWITCHES 9, 10, 11 & 12.

NOTES: UNLESS SPECIFIED OTHERWISE

MAIN PANEL PLUG-IN REQUIREMENTS

BIU2 T&F	BIU3 T&F	LS9 PED 2 BEACONS	LS10 PED 4 BEACONS	LS11 PED 6 BEACONS	LS12 PED 8 BEACONS	LS13 OL"A"	LS14 OL"B"	LS15 OL"C"	LS16 OL"D"
BIU1 T&F	LS1 VEH 1	LS2 VEH 2	LS3 VEH 3	LS4 VEH 4	LS5 VEH 5	LS6 VEH 6	LS7 VEH 7	LS8 VEH 8	FL1 □1CKT ■2CKT
FR1 L R V1 V5	FR2 L R V2 V6	FR3 L R V3 V7	FR4 L R V4 V8	⊗FR5 L R A C	⊗FR6 L R B D	K1 LS 24V CONT.			

■ DENOTES TYPE OF OPERATION AND/OR WHERE PLUG-IN IS REQUIRED. L = LEFT, R = RIGHT.

⊗ DENOTES WHERE "UNUSED RED" JUMPER PART NUMBER 32448G1 IS REQUIRED. INSTALL BETWEEN PINS 1 & 3 FOR LOAD SWITCH OR PINS 6 & 8 AND 5 & 7 FOR FLASH TRANSFER RELAY.

FLASH:
 □ ø2&6 YELLOW, ALL OTHERS RED.
 ■ ALL RED.
 ■ RELAYS DE-ENERGIZED FOR FLASH.
 □ RELAYS ENERGIZED FOR FLASH.

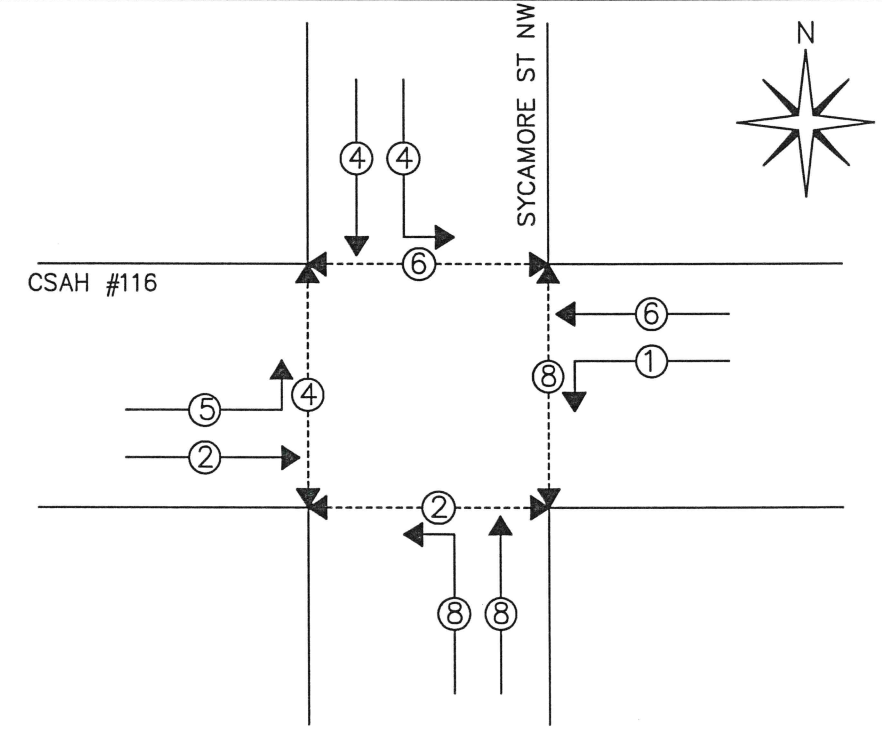

SHEET 1 OF 11

DESIGNER G.V. T.C.C.	DATE 02/03/97	ECONOLITE CONTROL PRODUCTS INC.	TRAFFIC CONTROL CORPORATION	780 W. BELDEN SUITE D ADDISON, IL 60101
DRAWN CM TCC	11/04/08			CABINET SPECIFICATION: TS2TYPE1 ANOKA COUNTY SPEC PLUG AND GO
CABINET SIZE	77" HOFFMAN GRAY	CUSTOMER:		CONTROLLER
INSPECTED		INTERSECTION: CSAH#116 AT SYCAMORE ST		FLASHER
APPROVED		LOCATION:		SW.PACKS
CUSTOMER P.O. SIG783-09-05	INSTALLED BY	SALES ORDER NO.	SIZE B	DRAWING #TS2AC16PG-

POLICE/AUX SWITCHES
ASSY. NO. 171-1076-510

POLICE/AUXILIARY SWITCH PANEL		
J1 PIN	FUNCTION	TO
A1	FILTER AC LINE (IN)	SW1-2
A2	SWITCHED AC LINE (OUT)	SW1-3
A3	FLASH CONTROL BUS (IN)	SW2-2
A4	SIGNAL BUS CONTROL (OUT)	SW5-5
A5	FLASH RELAY CONT. (OUT)	SW5-2
A6	START DELAY BUS (OUT)	SW1-3
B1	MMU FLSH CONT. BUS (OUT)	SW1-3
B2	SPARE	---
B3	SPARE	---
B4	SPARE	---
B5	SPARE	---
B6	SPARE	---
C1	MAN. CONT. ENABLE (OUT)	SW6-1
C2	LOGIC GROUND	SW3-1
C3	INTERVAL ADVANCE (OUT)	T2-B
C4	MMU STOP TIME (IN)	SW3-3
C5	CONT. STOP TIME (OUT)	SW3-2
C6	LOCAL FLASH STATUS (OUT)	SW2-5
D1	COORD FREE (OUT)	---
D2	ALARM 1 (OUT)	---
D3	ALARM 2 (OUT)	---
D4	LOADSWITCH TEST (OUT)	---
D5	MMU 24 VOLT MON. 2 (OUT)	---
D6	+24 VDC (IN)	---

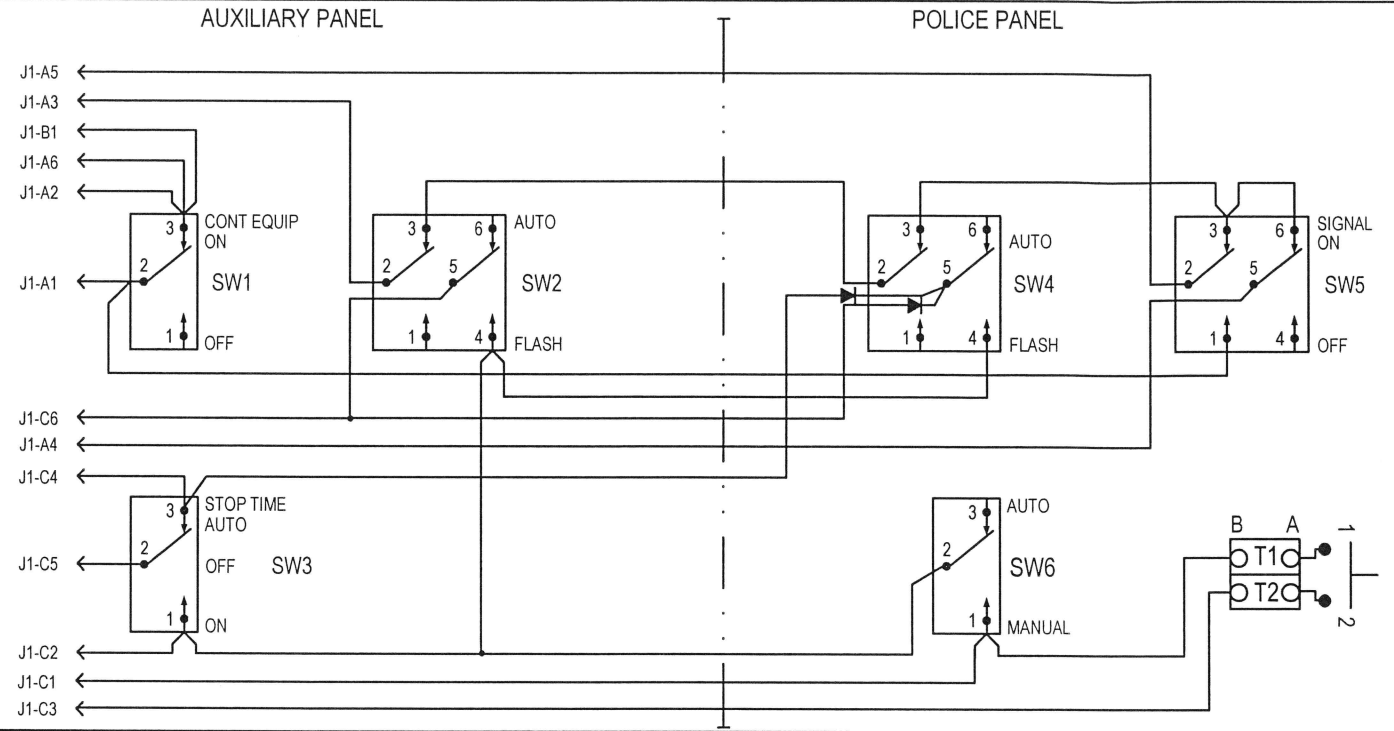

POWER/AUX PANEL (PAP)
PS4-001

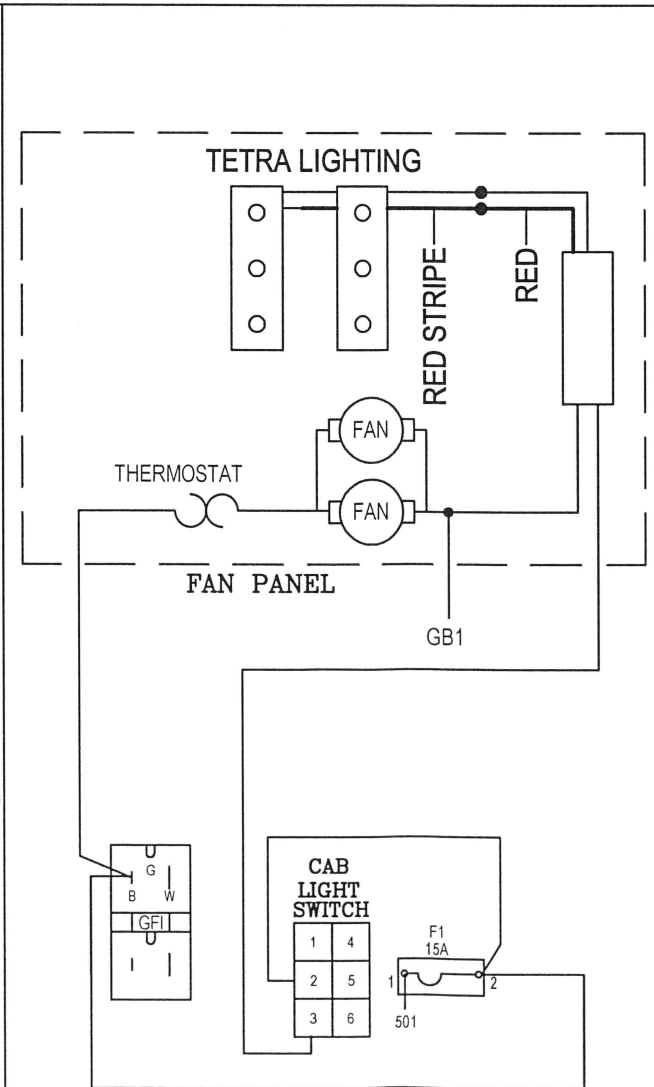
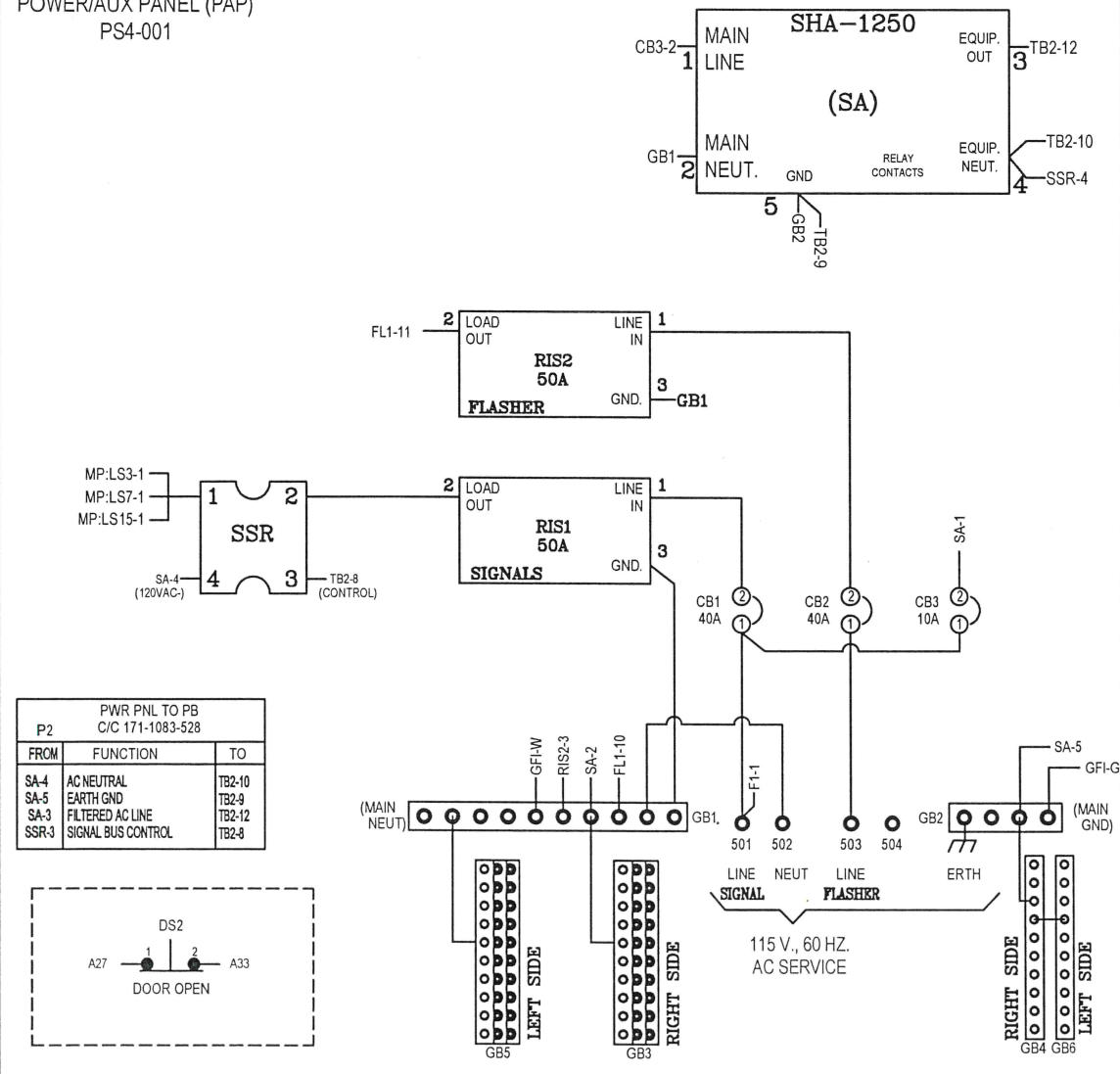

- J3-D6 A1
- MMB-1 A2
- MMA-37 A3
- K1-10 A4
- FR6-2 A5
- MMB-2 A6
- MMA-20 A7
- A8
- A9
- A10
- B1
- B2
- A-39 B3
- A-35 B4
- A-40 B5
- A-31 B6
- A-30 B7
- A-32 B8
- A-38 B9
- A-33 B10
- K1-9 C2
- B-3 C3
- B-4 C4
- A-35 C5
- K1-11 C6
- C7
- B-5 C8
- J1-31B C9
- C10
- J1-27B D1
- K1-10 D2
- D3
- K1-2 D4
- MMB-18 D5
- J3-A1 D6

(MAIN PANEL & C/C REFERENCES ONLY)

TO/FROM POLICE-AUXILIARY SWITCH PANEL		
PIN	FUNCTION	
A1	FILTER AC LINE (OUT)	
A2	SWITCHED AC LINE (IN)	
A3	FLASH CONTROL BUS (OUT)	
A4	SIGNAL BUS CONTROL (IN)	
A5	FLASH RELAY CONTROL (IN)	
A6	START DELAY AC BUS (IN)	
A7	MMU FLASH CONTROL BUS (IN)	
A8	SPARE	
A9	SPARE	
A10	SPARE	
B1	SPARE	
B2	SPARE	
B3	MANUAL CONT. ENABLE (IN)	
B4	LOGIC GROUND	
B5	OPT-INTERVAL ADVANCE (IN)	
B6	MMU STOP TIME (OUT)	
B7	CONTROLLER STOP TIME (IN)	
B8	LOCAL FLASH STATUS (IN)	
B9	COORD FREE (IN)	
B10	ALARM 1 (IN)	
C1	ALARM 2 (IN)	
C2	LOADSWITCH TEST (IN)	
C3	MMU 24 VOLT MON. 2 (IN)	
C4	+24 VDC	
C5	LOGIC GROUND	
C6	+24 VDC (IN)	
C7	---	
C8	MMU FAULT MONITOR (IN)	
C9	LINE FREQ. REFERENCE (IN)	
C10	---	
D1	12 VAC (IN)	
D2	SIGNAL BUS CONTROL (IN)	
D3	---	
D4	FILTERED AC NEUTRAL (IN)	
D5	CONT. EQUIP. AC LINE (OUT)	
D6	FILTERED AC LINE (IN)	

TO: POL/AUX ASSY.

TO: PBA

MP P3	MAIN PANEL/CONTROLLER PWR. C/C 171-1083-504/524	TO POL/AUX P1
PIN	FUNCTION	PIN
A1	FILTER AC LINE (OUT)	A1
A2	SWITCHED AC LINE (IN)	A2
A3	FLASH CONTROL BUS (OUT)	A3
A4	SIGNAL BUS CONTROL (IN)	A4
A5	FLASH RELAY CONTROL (IN)	A5
A6	START DELAY AC BUS (IN)	A6
A7	MMU FLASH CONTROL BUS (IN)	B1
A8	SPARE	B2
A9	SPARE	B3
A10	SPARE	B4
B1	SPARE	B5
B2	SPARE	B6
B3	OPT-MAN. CONT. ENABLE (IN)	C1
B4	LOGIC GROUND	C2
B5	OPT-INTERVAL ADVANCE (IN)	C3
B6	MMU STOP TIME (OUT)	C4
B7	CONTROLLER STOP TIME (IN)	C5
B8	LOCAL FLASH STATUS (IN)	C6
B9	OPT-COORD FREE (IN)	D1
B10	OPT-ALARM 1 (IN)	D2
C1	OPT-ALARM 2 (IN)	D3
C2	OPT-LOADSWITCH TEST (IN)	D4
C3	MMU 24 VOLT MON. 2 (IN)	D5
C4	+24 VDC	D6
PART OF 171-1083-504/524		TO PB:(X)
C5	LOGIC GROUND	A1
C6	+24 VDC (IN)	A2
C7	---	A3
C8	MMU FAULT MONITOR (IN)	A4
C9	LINE FREQ. REFERENCE (IN)	B1
C10	---	B2
D1	12 VAC (IN)	B3
D2	SIGNAL BUS CONTROL (IN)	B4
D3	---	C1
D4	FILTERED AC NEUTRAL (IN)	C2
D5	CONT. EQUIP. AC LINE (OUT)	C3
D6	FILTERED AC LINE (IN)	C4

CONFIRMATION BEACONS

EVP 3 = 1-6
 EVP 4 = 2-5
 EVP 5 = 8
 EVP 6 = 4

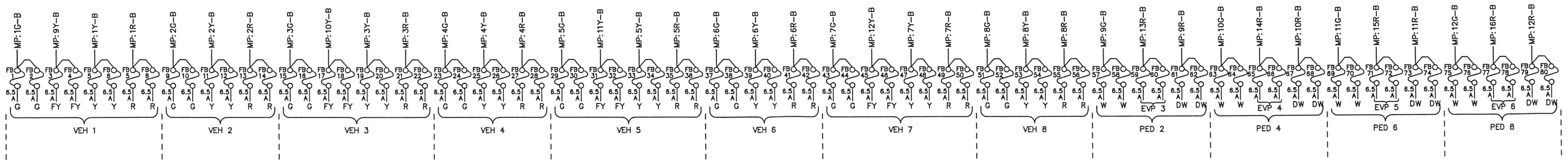
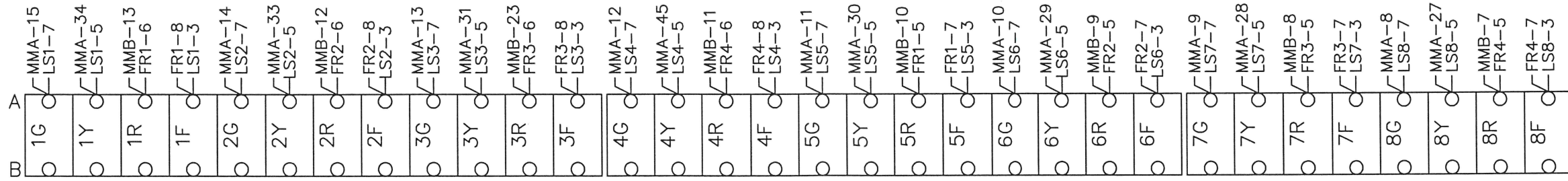
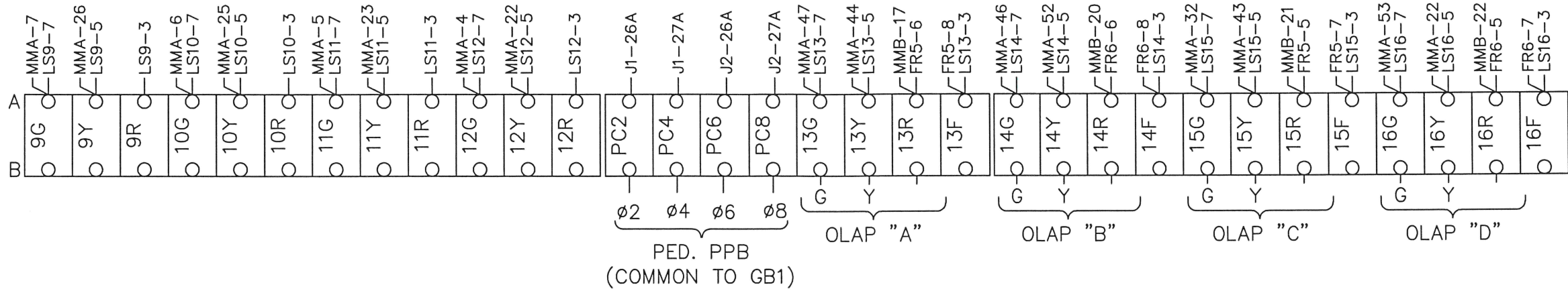

SIGNAL FIELD TERMINALS

①
2.2K
10W

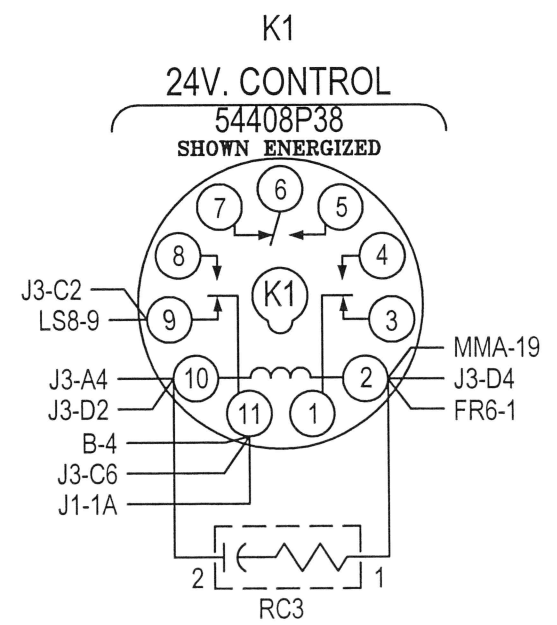
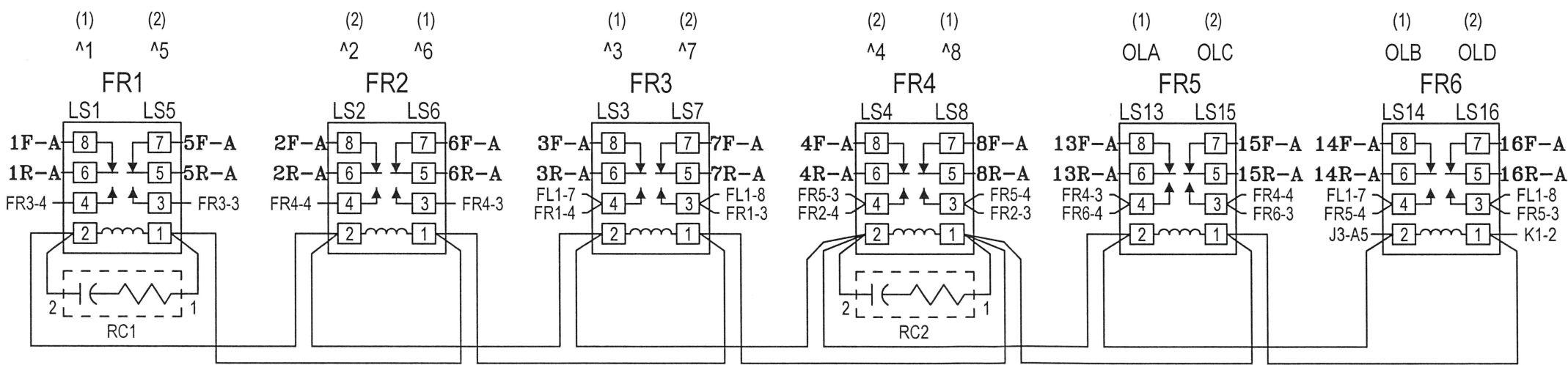
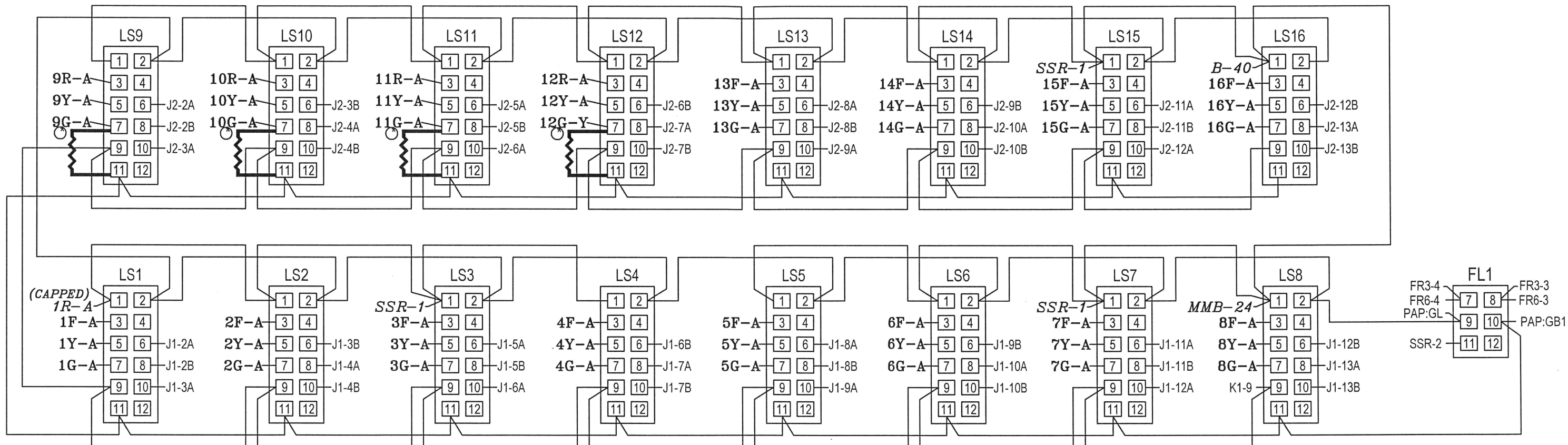

LOADBAY AND FLASH RELAY'S

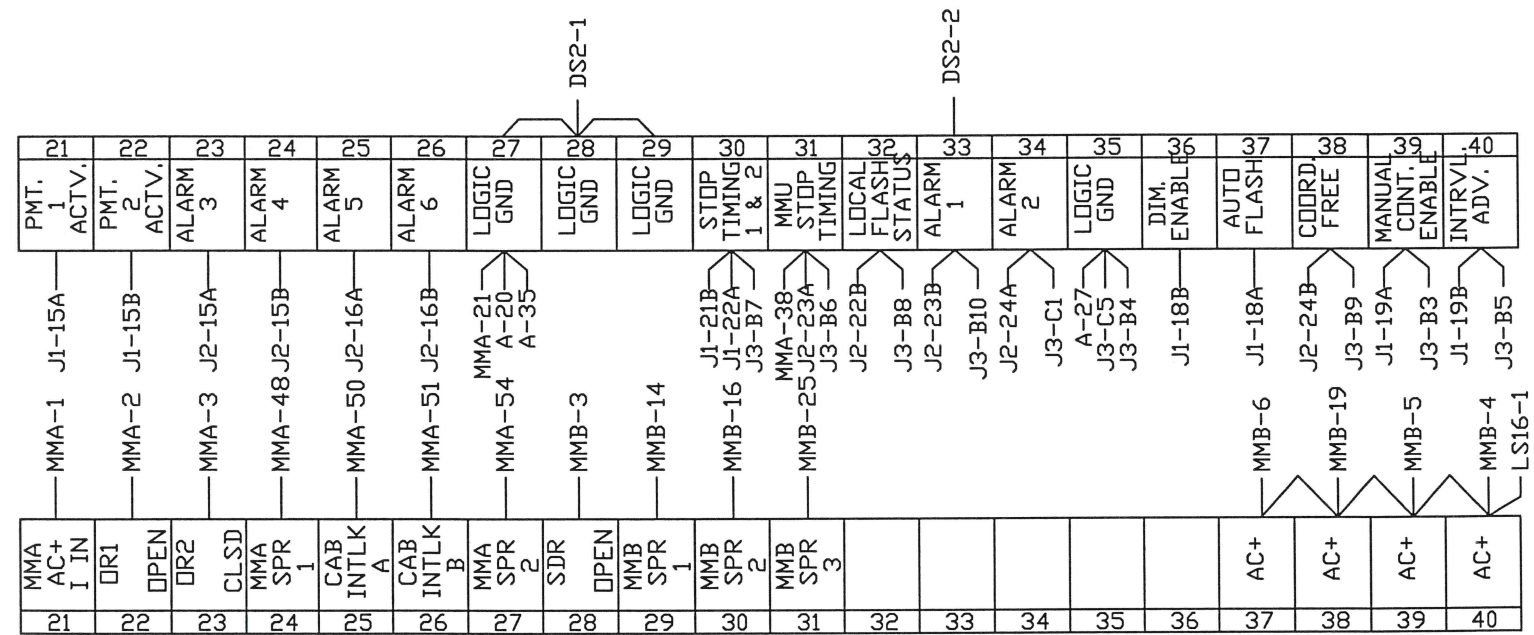
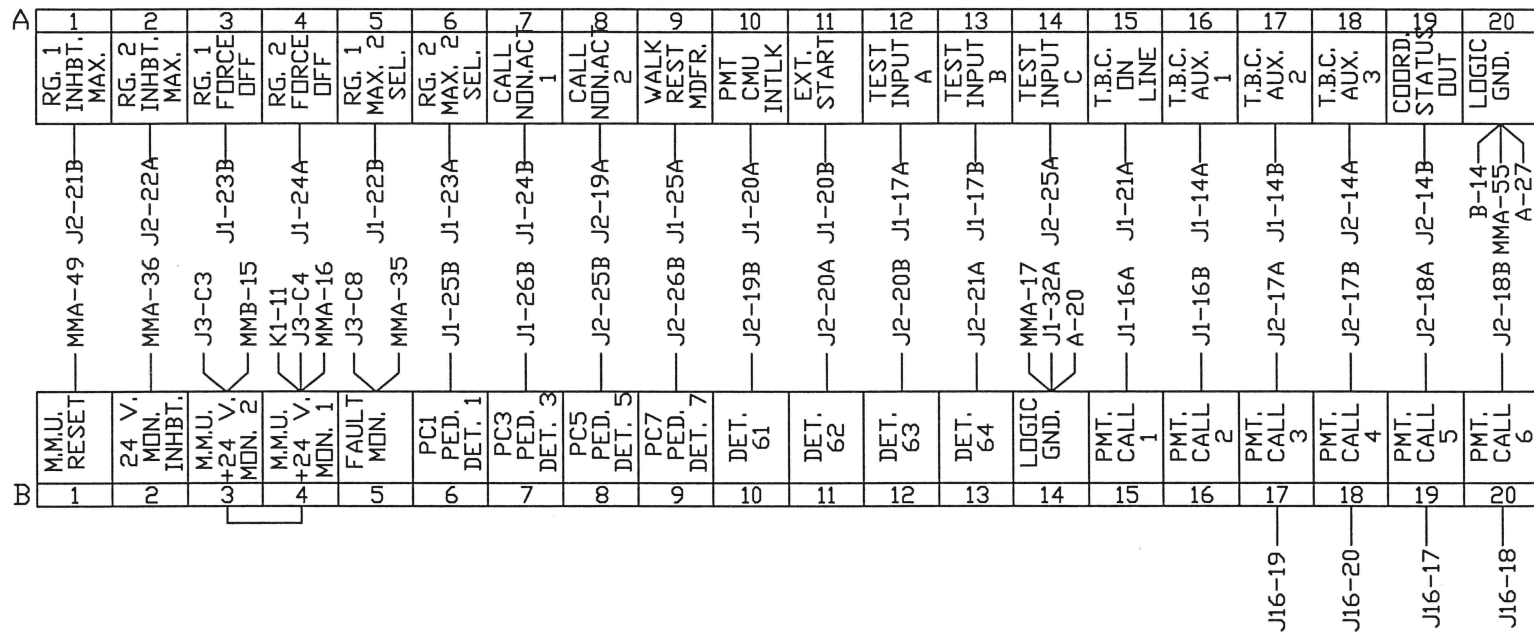

INTERFACE TERMINAL BLOCKS

J1 BIU #1		
PIN	FUNCTION	TO
1A	+24 VDC	K1-11
1B	+24 VDC	J2-1B
2A	LS1 RED	LS1-6
2B	LS1 YELLOW	LS1-8
3A	LS1 GREEN	LS1-10
3B	LS2 RED	LS2-6
4A	LS2 YELLOW	LS2-8
4B	LS2 GREEN	LS2-10
5A	LS3 RED	LS3-6
5B	LS3 YELLOW	LS3-8
6A	LS3 GREEN	LS3-10
6B	LS4 RED	LS4-6
7A	LS4 YELLOW	LS4-8
7B	LS4 GREEN	LS4-10
8A	LS5 RED	LS5-6
8B	LS5 YELLOW	LS5-8
9A	LS5 GREEN	LS5-10
9B	LS6 RED	LS6-6
10A	LS6 YELLOW	LS6-8
10B	LS6 GREEN	LS6-10
11A	LS7 RED	LS7-6
11B	LS7 YELLOW	LS7-8
12A	LS7 GREEN	LS7-10
12B	LS8 RED	LS8-6
13A	LS8 YELLOW	LS8-8
13B	LS8 GREEN	LS8-10
14A	TBC AUX 1	A-16
14B	TBC AUX 2	A-17
15A	PMT ACT 1	A-21
15B	PMT ACT 2	A-22
16A	PMT CALL 1	B-15
16B	PMT CALL 2	B-16
17A	TEST A	A-12
17B	TEST B	A-13
18A	AUTO FLASH	A-37
18B	DIM. ENABLE	A-36
19A	MANUAL CONT.	A-39
19B	INT. ADVANCE	A-40
20A	PMT CMU INTLK	A-10
20B	EXT. START	A-11
21A	TBC ONLINE	A-15
21B	STOP TIME (1)	A-30
22A	STOP TIME (2)	A-30
22B	MAX. 2 (1)	A-5
23A	MAX. 2 (2)	A-6
23B	FORCE OFF (1)	A-3
24A	FORCE OFF (2)	A-4
24B	CNA 1	A-7
25A	WALK REST MOD.	A-9
25B	PED. ISO. 1	B-6
26A	PED. ISO. 2	PC2-A
26B	PED. ISO. 3	B-7
27A	PED. ISO. 4	PC4-A
27B	PED. ISO. COMN.	J3-D1
28A	ADDR. SEL. 0	-----
28B	ADDR. SEL. 1	-----
29A	ADDR. SEL. 2	-----
29B	ADDR. SEL. 3	-----
30A	RESERVED	-----
30B	RESERVED	-----
31A	EARTH GND.	LS12-2
31B	LINE FREQ. REF.	J3-C9
32A	LOGIC GND.	B-14
32B	LOGIC GND.	J2-32A

J2 BIU #2		
PIN	FUNCTION	TO
1A	+24 VDC	J2-1B
1B	+24 VDC	J1-1B
2A	LS9 RED	LS9-6
2B	LS9 YELLOW	LS9-8
3A	LS9 GREEN	LS9-10
3B	LS10 RED	LS10-6
4A	LS10 YELLOW	LS10-8
4B	LS10 GREEN	LS10-10
5A	LS11 RED	LS11-6
5B	LS11 YELLOW	LS11-8
6A	LS11 GREEN	LS11-10
6B	LS12 RED	LS12-6
7A	LS12 YELLOW	LS12-8
7B	LS12 GREEN	LS12-10
8A	LS13 RED	LS13-6
8B	LS13 YELLOW	LS13-8
9A	LS13 GREEN	LS13-10
9B	LS14 RED	LS14-6
10A	LS14 YELLOW	LS14-8
10B	LS14 GREEN	LS14-10
11A	LS15 RED	LS15-6
11B	LS15 YELLOW	LS15-8
12A	LS15 GREEN	LS15-10
12B	LS16-RED	LS16-6
13A	LS16-YELLOW	LS16-8
13B	LS16-GREEN	LS16-10
14A	TBC AUX 3	A-18
14B	COORD. STATUS	A-19
15A	ALARM 3	A-23
15B	ALARM 4	A-24
16A	ALARM 5	A-25
16B	ALARM 6	A-26
17A	PMT CALL 3	B-17
17B	PMT CALL 4	B-18
18A	PMT CALL 5	B-19
18B	PMT CALL 6	B-20
19A	CNA 2	A-8
19B	VEH. DET. 61	B-10
20A	VEH. DET. 62	B-11
20B	VEH. DET. 63	B-12
21A	VEH. DET. 64	B-13
21B	INHIBIT MAX (1)	A-1
22A	INHIBIT MAX (2)	A-2
22B	LOCAL FLASH	A-32
23A	MMU FLASH	A-31
23B	ALARM 1	A-33
24A	ALARM 2	A-34
24B	COORD FREE IN	A-38
25A	TEST C	A-14
25B	PED. ISO. 5	B-8
26A	PED. ISO. 6	PC6-A
26B	PED. ISO. 7	B-9
27A	PED. ISO. 8	PC8-A
27B	PED. ISO. COMN.	J1-27B
28A	ADDR. SEL. 0	J2-32A
28B	ADDR. SEL. 1	-----
29A	ADDR. SEL. 2	-----
29B	ADDR. SEL. 3	-----
30A	RESERVED	-----
30B	RESERVED	-----
31A	EARTH GND.	J1-31A
31B	LINE FREQ. REF.	J1-31B
32A	LOGIC GND.	J1-32B
32B	LOGIC GND.	J2-32A

MAIN PANEL CONTROL POWER C/C 171-1083-504	
PIN	FUNCTION
A1	LOGIC GROUND
A2	+24 VDC (IN)
A3	----
A4	MMU FAULT MONITOR (IN)
B1	LINE FREQ. REFERENCE (IN)
B2	----
B3	+12 VAC (IN)
B4	SIGNAL BUS CONTROL (IN)
C1	----
C2	FILTERED AC NEUTRAL (IN)
C3	CONT. EQUIP. AC LINE (OUT)
C4	FILTERED AC LINE (IN)

CONTROLLER POWER (CCA2) C/C 171-1083-503			
WIRE	PIN	SIGNAL	TO
1	A	FAULT MONITOR	PB-4
2	U	AC NEUTRAL	PB-10
3	V	EARTH GROUND	PB-9
4	W	LOGIC GROUND	PB-1
5	P	AC LINE	PB-11
6	SHL	EARTH GROUND	CCA2-V

TYPE 1 CONTROLLER POWER C/C 171-1083-502		
PIN	FUNCTION	TO
A	AC NEUTRAL	PB-10
B	---	---
C	AC LINE	PB-11
D	---	---
E	+12 VDC	PB-2
F	---	---
G	FAULT MON.	PB-4
H	LOGIC GND.	PB-1
I	EARTH GND.	PB-9
J	---	---
SHL	EARTH GND.	PIN H

CABINET POWER SUPPLY C/C 171-1083-511		
PIN	FUNCTION	TO
A	AC NEUTRAL	PB-10
B	LINE FREQUENCY REF.	PB-5
C	AC LINE	PB-11
D	+12 VDC	PB-3
E	+24 VDC	PB-2
F	RESERVED	---
G	LOGIC GND.	PB-1
H	EARTH GND.	PB-9
I	+12 VAC	PB-7
J	RESERVED	---
SHL	EARTH GND.	PIN H

CONTROLLER PORT 1 CONNECTOR			
PIN	SIGNAL	TO	FUNCTION
1	TWISTED PAIR 1+	SDLC-1	CONT TXD+
2	LOGIC GND.	---	---
3	TWISTED PAIR 2+	SDLC-4	CONT TXC+
4	LOGIC GND.	---	---
5	TWISTED PAIR 3+	SDLC-7	CONT RXD+
6	LOGIC GND.	---	---
7	TWISTED PAIR 4+	SDLC-10	CONT RXC+
8	LOGIC GND.	---	---
9	TWISTED PAIR 1- PORT 1 DISABLE	SDLC-2	CONT TXD-
10	TWISTED PAIR 2-	SDLC-5	CONT TXC-
11	EARTH GND.	SHIELD WIRE	---
12	TWISTED PAIR 3-	SDLC-8	CONT RXD-
13	RESERVED	---	---
14	TWISTED PAIR 4-	SDLC-11	CONT RXC-

MMU & BIU PORT 1 CONNECTOR			
PIN	SIGNAL	TO	FUNCTION
1	TWISTED PAIR 1+	SDLC-1	BIU RXD+
2	LOGIC GND.	---	---
3	TWISTED PAIR 2+	SDLC-4	BIU RXC+
4	LOGIC GND.	---	---
5	TWISTED PAIR 3+	SDLC-7	BIU TXD+
6	LOGIC GND.	---	---
7	TWISTED PAIR 4+	SDLC-10	BIU TXC+
8	LOGIC GND.	---	---
9	TWISTED PAIR 1- PORT 1 DISABLE	SDLC-2	BIU RXD-
10	TWISTED PAIR 2-	SDLC-5	BIU RXC-
11	EARTH GND.	SHIELD WIRE	---
12	TWISTED PAIR 3-	SDLC-8	BIU TXD-
13	RESERVED	---	---
14	TWISTED PAIR 4-	SDLC-11	BIU TXC-

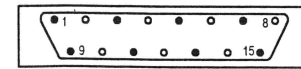

FRONT VIEW OF BU1 - BU5

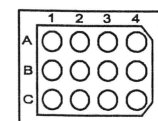

FRONT VIEW OF J1-J6

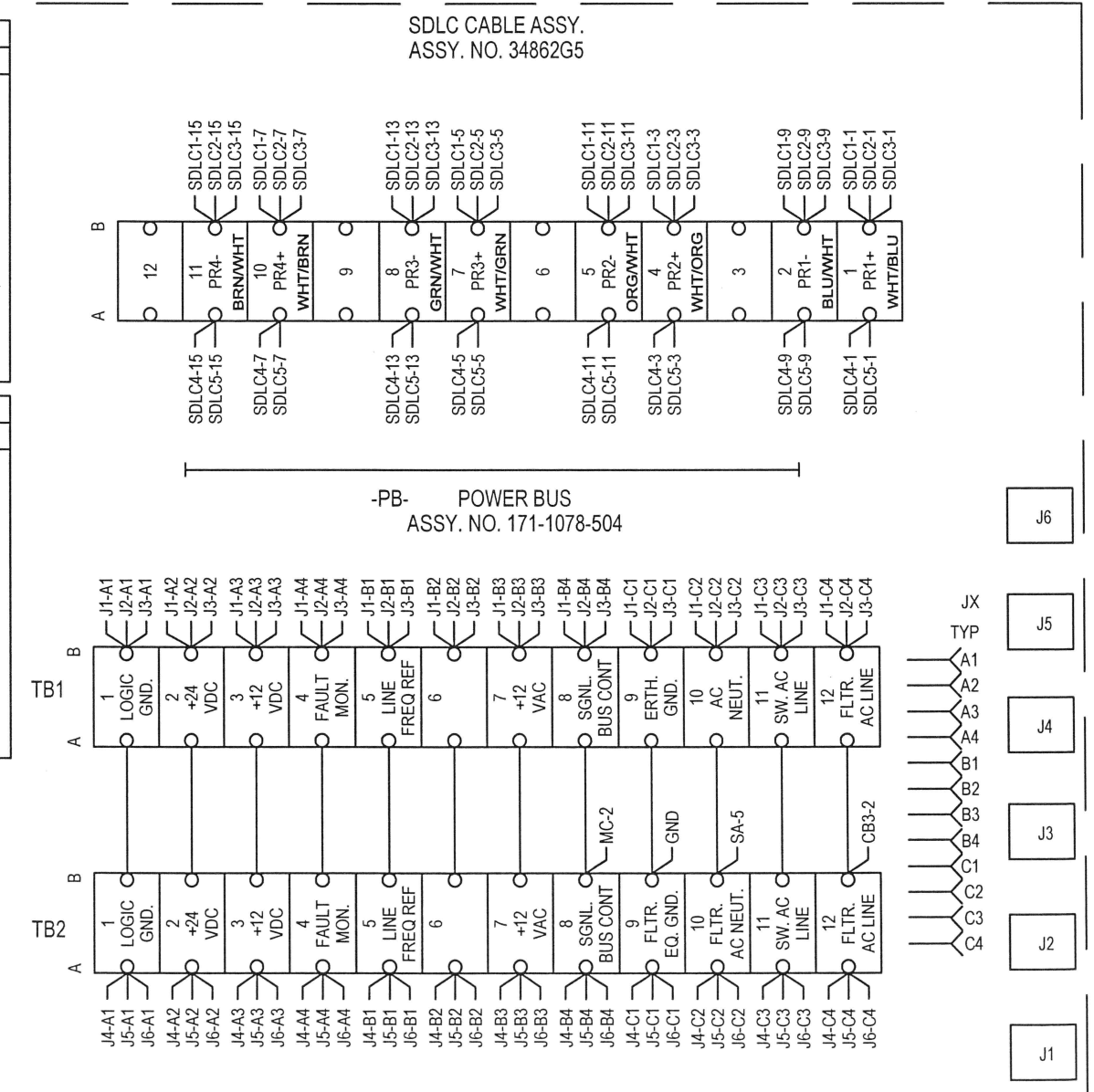

BIU AND CONNECTING CABLES

WIRE LIST FOR NEMA MALFUNCTION MANAGEMENT UNIT

CONNECTOR "A" (MMA)					CONNECTOR "B" (MMB)				
PIN	WIRE	MON. FUNCTION	TO	SIG. FUNCTION	PIN	WIRE	MON. FUNCTION	TO	SIG. FUNCTION
A	A-1	AC+ I INPUT	B21		A	B-1	AC+ II INPUT	J3-A2	MMU POWER
B	A-2	OUT RLY 1 OPEN	B22		B	B-2	S. DLY RLY COMM.	J3-A6	MMU POWER
C	A-3	OUT RLY 2 CLSD	B23		C	B-3	S. DLY RLY OPEN	B28	
D	A-4	CH. 12 GREEN	12G-A	^8 WLK	D	B-4	CH. 12 RED	B40	
E	A-5	CH. 11 GREEN	11G-A	^6 WLK	E	B-5	CH. 11 RED	B39	
F	A-6	CH. 10 GREEN	10G-A	^4 WLK	F	B-6	CH. 9 RED	B37	
G	A-7	CH. 9 GREEN	9G-A	^2 WLK	G	B-7	CH. 8 RED	8R-A	^8 RED
H	A-8	CH. 8 GREEN	8G-A	^8 GRN	H	B-8	CH. 7 RED	7R-A	^7 RED
J	A-9	CH. 7 GREEN	7G-A	^7 GRN	J	B-9	CH. 6 RED	6R-A	^6 RED
K	A-10	CH. 6 GREEN	6G-A	^6 GRN	K	B-10	CH. 5 RED	5R-A	^5 RED
L	A-11	CH. 5 GREEN	5G-A	^5 GRN	L	B-11	CH. 4 RED	4R-A	^4 RED
M	A-12	CH. 4 GREEN	4G-A	^4 GRN	M	B-12	CH. 2 RED	2R-A	^2 RED
N	A-13	CH. 3 GREEN	3G-A	^3 GRN	N	B-13	CH. 1 RED	1R-A	^1 RED
P	A-14	CH. 2 GREEN	2G-A	^2 GRN	P	B-14	(SPARE 1)	B29	
R	A-15	CH. 1 GREEN	1G-A	^1 GRN	R	B-15	+24V MONITOR II	B-3	+24V MON. II
S	A-16	+24V MON. I	B-4	LS +24V MON.	S	B-16	(SPARE 2)	B30	
T	A-17	LOGIC GND	B-14	LOGIC GND	T	B-17	CH. 13 RED	13R-A	OLA RED
U	A-18	CHASSIS GND	LS7-2	EARTH GND.	U	B-18	S. DLY RLY CLSD	J3-D5	CONT. POWER
V	A-19	AC- (COMMON)	K1-2	AC NEUTRAL	V	B-19	CH. 10 RED	B38	
W	A-20	OUT RLY 1 COM.	J3-A7	SIG BUS CONT	W	B-20	CH. 14 RED	14R-A	OLB RED
X	A-21	OUT RLY 2 COM.	A-27	LOGIC GND	X	B-21	CH. 15 RED	15R-A	OLC RED
Y	A-22	CH. 12 YELLOW	12Y-A	VEH. 7 FYA	Y	B-22	CH. 16 RED	16R-A	OLD RED
Z	A-23	CH. 11 YELLOW	11Y-A	VEH. 5 FYA	Z	B-23	CH. 3 RED	3R-A	^3 RED
a	A-24	CH. 10 WALK	----		a	B-24	RED ENABLE	LS8-1	SIG BUS CON.
b	A-25	CH. 10 YELLOW	10Y-A	VEH. 3 FYA	b	B-25	(SPARE 3)	B31	
c	A-26	CH. 9 YELLOW	9Y-A	VEH. 1 FYA	c	B-26	LOCAL FLASH IN	-T-	POL/AX FLSH
d	A-27	CH. 8 YELLOW	8Y-A	^8 YEL		B-27	SHELL GROUND	LS6-2	EARTH GND.
e	A-28	CH. 7 YELLOW	7Y-A	^7 YEL					
f	A-29	CH. 6 YELLOW	6Y-A	^6 YEL					
g	A-30	CH. 5 YELLOW	5Y-A	^5 YEL					
h	A-31	CH. 3 YELLOW	3Y-A	^3 YEL					
i	A-32	CH. 15 GREEN	15G-A	OLC GRN					
j	A-33	CH. 2 YELLOW	2Y-A	^2 YEL					
k	A-34	CH. 1 YELLOW	1Y-A	^1 YEL					
m	A-35	CONT. VOLT. MON.	B-5	VOLT. MON.					
n	A-36	+24V MON. INH.	B-2						
p	A-37	OUT RLY 1 CLSD	J3-A3						
q	A-38	OUT RLY 2 OPEN	A-31	STOP TIME					
r	A-39	CH. 12 WALK	----						
s	A-40	CH. 11 WALK	----						
t	A-41	CH. 9 WALK	----						
u	A-42	CH. 16 YELLOW	16Y-A	OLD YEL					
v	A-43	CH. 15 YELLOW	15Y-A	OLC YEL					
w	A-44	CH. 13 YELLOW	13Y-A	OLA YEL					
x	A-45	CH. 4 YELLOW	4Y-A	^4 YEL					
y	A-46	CH. 14 GREEN	14G-A	OLB GRN					
z	A-47	CH. 13 GREEN	13G-A	OLA GRN					
AA	A-48	(SPARE 1)	B24						
BB	A-49	RESET	B-1						
CC	A-50	CAB. INTLK A	B25						
DD	A-51	CAB. INTLK B	B26						
EE	A-52	CH. 14 YELLOW	14Y-A	OLB YRL					
FF	A-53	CH. 16 GREEN	16G-A	OLD GRN					
GG	A-54	(SPARE 2)	B27						
HH	A-55	TYPE SELECT	A-20	MMU/CMU SEL.					
	A-56	SHELL GND	LS15-2	EARTH GND.					

NOTES FOR 16 CHANNEL M.M.U.

- (1) RELAY CONTACT POSITIONS SPECIFIED ARE FOR NON-CONFLICT MODE.
- (2) TO PROGRAM MMU, SOLDER JUMPERS IN PROGRAMMING CARD FOR ALL PERMISSABLE PHASE MOVEMENTS, MINIMUM CHANGE DISABLE FOR ALL PEDESTRIAN CHANNELS, AND MIN. FLASH, VOLTAGE MON., AND 24V. MON. LATCH OPTIONS AS DESIRED.

M.M.U. CHANNEL ASSIGNMENTS

CH. 1 =	L/S 1 =	^1 VEH.
CH. 2 =	L/S 2 =	^2 VEH.
CH. 3 =	L/S 3 =	^3 VEH.
CH. 4 =	L/S 4 =	^4 VEH.
CH. 5 =	L/S 5 =	^5 VEH.
CH. 6 =	L/S 6 =	^6 VEH.
CH. 7 =	L/S 7 =	^7 VEH.
CH. 8 =	L/S 8 =	^8 VEH.
CH. 9 =	L/S 9 =	^2 PED. / VEH. 1 FYA
CH. 10 =	L/S 10 =	^4 PED. / VEH. 3 FYA
CH. 11 =	L/S 11 =	^6 PED. / VEH. 5 FYA
CH. 12 =	L/S 12 =	^8 PED. / VEH. 7 FYA
CH. 13 =	L/S 13 =	O'LAP A VEH.
CH. 14 =	L/S 14 =	O'LAP B VEH.
CH. 15 =	L/S 15 =	O'LAP C VEH.
CH. 16 =	L/S 16 =	O'LAP D VEH.

MMU PROGRAM CARD

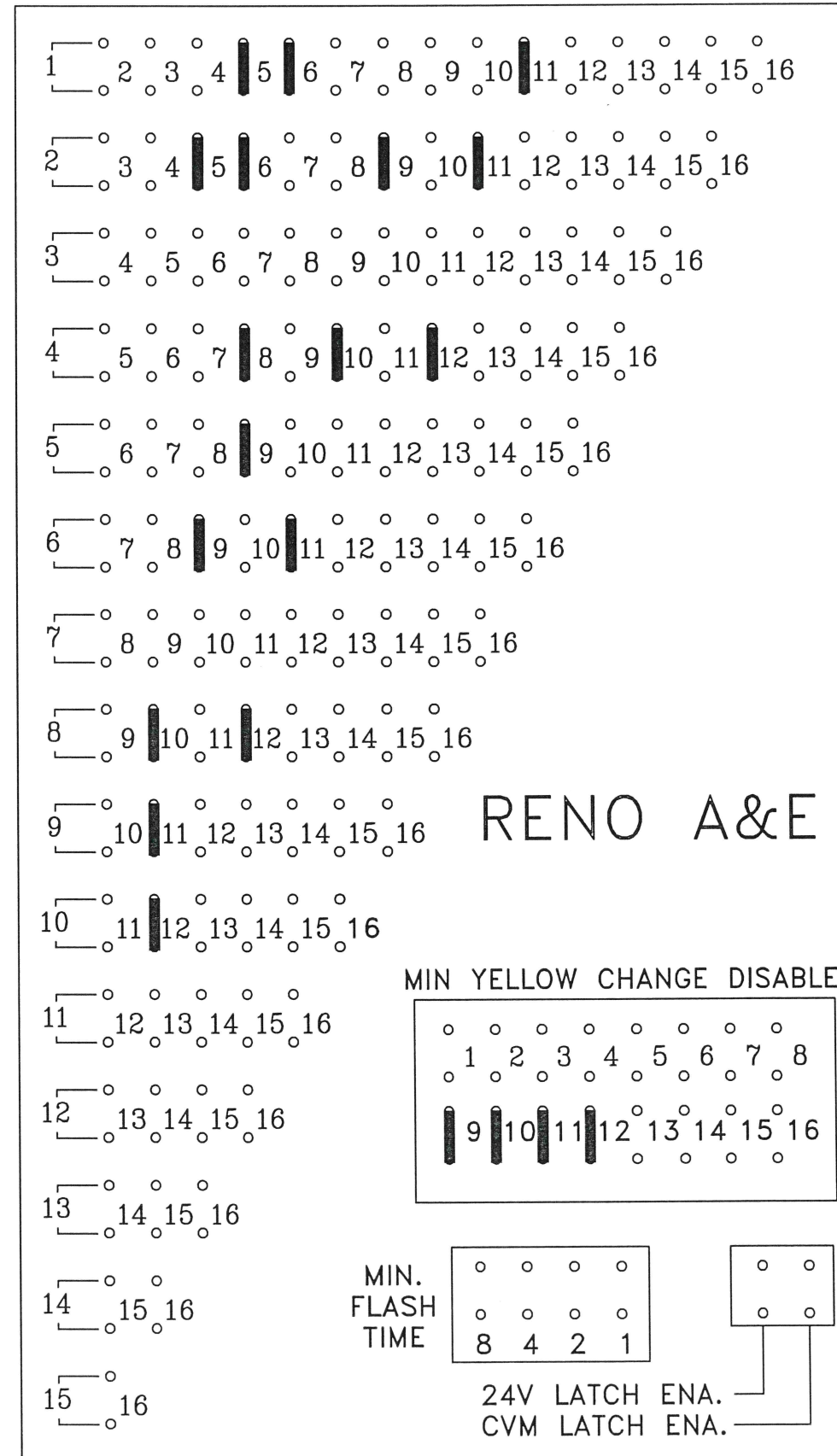

M.M.U. C/C'S AND PROGRAM CARD

DETECTOR RACK #1 34030G1

POWER SUPPLY OR B.I.U.	L3	L1	L7	L5	L11	L9	L15	L13	PMT 5	PMT 3	PGM. CARD
	5-1	1-1	5-1	2-1	4-3	4-1	8-3	8-1	<input type="checkbox"/> 2CH OPTICOM/ OPIC CH. C CH. D	<input type="checkbox"/> 4CH <input type="checkbox"/> 2CH OPTICOM/ OPIC CH. A CH. B	
	<input type="checkbox"/> 2CH	<input type="checkbox"/> 2CH	<input type="checkbox"/> 2CH	<input type="checkbox"/> 2CH	<input type="checkbox"/> 2CH	<input type="checkbox"/> 2CH	<input type="checkbox"/> 2CH	<input type="checkbox"/> 2CH	<input type="checkbox"/> 2CH		
	5-2	1-2	5-2	2-2		4-2		8-2			
	L4	L2	L8	L6	L12	L10	L16	L14	PMT 6	PMT 4	

J13 C/C 171-1083-515 DC POWER	J16 C/C 33284G8 EXP. OUTPUTS	J14 C/C 33284G2 LPS 1-8	J18 C/C 33284G9 SYS. OUTPUTS	J15 C/C 33284G3 LPS 9-16	J17 C/C 171-1083-515 AC POWER	J19 C/C 33284G17 PGM. CARD
--	---	--------------------------------------	---	---------------------------------------	--	---

①

ADDRESS TABLE					
RACK #	JMPR	DET. #S	RACK #	JMPR	DET. #S
1	0000	1-16	5	0000	65-80
2	0000	17-32	6	0000	81-96
3	0000	33-48	7	0000	97-112
4	0000	49-64	8	0000	113-128

DETECTOR ASSIGNMENTS		
CONT. INPUT	PHASE ASGN.	DETECTOR TYPE
1	1-1	
2	1-2	
3	5-1	
4	5-2	
5	2-1	
6	2-2	
7	6-1	
8	6-2	
9	4-1	
10	4-2	
11	4-3	
12		
13	8-1	
14	8-2	
15	8-3	
16		
17		
18		
19		
20		
21		
22		
23		
24		
25		
26		
26		
28		
29		
30		
31		
32		

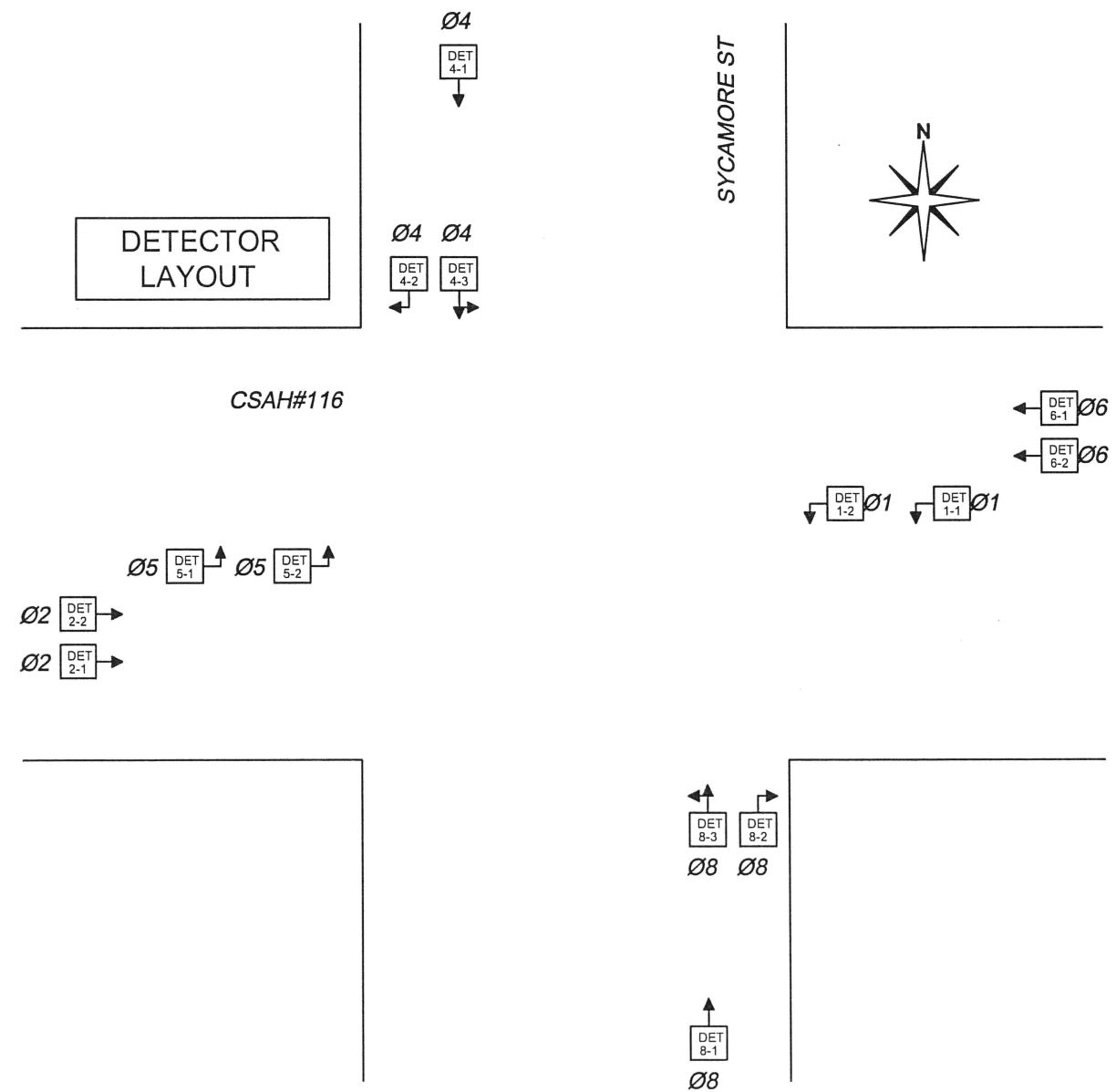

DETECTOR RACK PROGRAMMING JUMPERS																													
DET. TYPE	JP1	JP2	SLOT 1/2 ①							SLOT 3/4 ①							SLOT 5/6 ①							SLOT 7/8 ①					
			JP3	JP4	JP5	JP6	JP7	JP8	JP9	JP10	JP11	JP12	JP13	JP14	JP15	JP16	JP17	JP18	JP19	JP20	JP21	JP22	JP23	JP24	JP25	JP26	JP27	JP28	JP29
① TS-1	NO	NO	<input type="checkbox"/>	<input type="checkbox"/>	<input type="checkbox"/>	<input type="checkbox"/>	<input type="checkbox"/>	<input type="checkbox"/>	<input type="checkbox"/>	<input type="checkbox"/>	<input type="checkbox"/>	<input type="checkbox"/>	<input type="checkbox"/>	<input type="checkbox"/>	<input type="checkbox"/>	<input type="checkbox"/>	<input type="checkbox"/>	<input type="checkbox"/>	<input type="checkbox"/>	<input type="checkbox"/>	<input type="checkbox"/>	<input type="checkbox"/>	<input type="checkbox"/>	<input type="checkbox"/>	<input type="checkbox"/>	<input type="checkbox"/>	<input type="checkbox"/>	<input type="checkbox"/>	
② TS-2	YES	YES	<input type="checkbox"/>	<input type="checkbox"/>	<input type="checkbox"/>	<input type="checkbox"/>	<input type="checkbox"/>	<input type="checkbox"/>	<input type="checkbox"/>	<input type="checkbox"/>	<input type="checkbox"/>	<input type="checkbox"/>	<input type="checkbox"/>	<input type="checkbox"/>	<input type="checkbox"/>	<input type="checkbox"/>	<input type="checkbox"/>	<input type="checkbox"/>	<input type="checkbox"/>	<input type="checkbox"/>	<input type="checkbox"/>	<input type="checkbox"/>	<input type="checkbox"/>	<input type="checkbox"/>	<input type="checkbox"/>	<input type="checkbox"/>	<input type="checkbox"/>	<input type="checkbox"/>	
③ LM-632T 262-FC	NO	NO	<input type="checkbox"/>	<input type="checkbox"/>	<input type="checkbox"/>	<input type="checkbox"/>	<input type="checkbox"/>	<input type="checkbox"/>	<input type="checkbox"/>	<input type="checkbox"/>	<input type="checkbox"/>	<input type="checkbox"/>	<input type="checkbox"/>	<input type="checkbox"/>	<input type="checkbox"/>	<input type="checkbox"/>	<input type="checkbox"/>	<input type="checkbox"/>	<input type="checkbox"/>	<input type="checkbox"/>	<input type="checkbox"/>	<input type="checkbox"/>	<input type="checkbox"/>	<input type="checkbox"/>	<input type="checkbox"/>	<input type="checkbox"/>	<input type="checkbox"/>	<input type="checkbox"/>	
④ MAG.	NO	NO	<input type="checkbox"/>	<input type="checkbox"/>	<input type="checkbox"/>	<input type="checkbox"/>	<input type="checkbox"/>	<input type="checkbox"/>	<input type="checkbox"/>	<input type="checkbox"/>	<input type="checkbox"/>	<input type="checkbox"/>	<input type="checkbox"/>	<input type="checkbox"/>	<input type="checkbox"/>	<input type="checkbox"/>	<input type="checkbox"/>	<input type="checkbox"/>	<input type="checkbox"/>	<input type="checkbox"/>	<input type="checkbox"/>	<input type="checkbox"/>	<input type="checkbox"/>	<input type="checkbox"/>	<input type="checkbox"/>	<input type="checkbox"/>	<input type="checkbox"/>	<input type="checkbox"/>	

DETECTOR LOOP
INTERFACE #1
ASSY. 34040G1

J1
TO DR1:J14
C/C 33284G2

J2
TO DR1:J15
C/C 33284G3

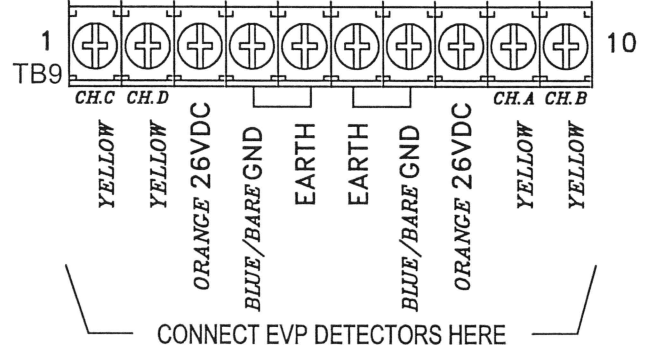
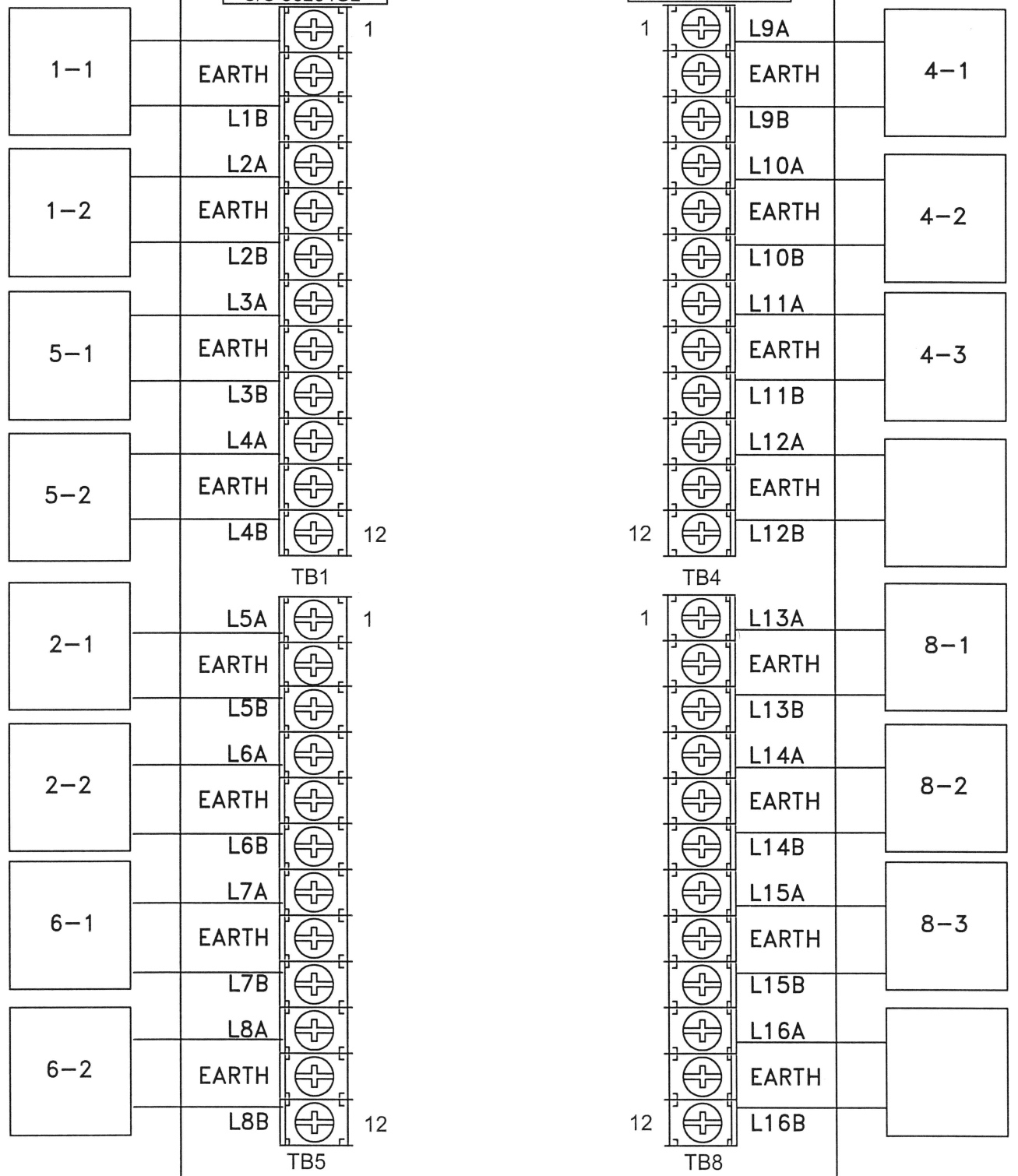

DET. LOOPS 9-16 (J15) C/C 33284G3

PIN	SIGNAL	TO
1	LOOP 9+	LPI2:TB4-1
2	LOOP 9-	LPI2: TB4-3
3	LOOP 10+	LPI2: TB4-4
4	LOOP 10-	LPI2: TB4-6
5	LOOP 11+	LPI2: TB4-7
6	LOOP 11-	LPI2: TB4-9
7	LOOP 12+	LPI2: TB4-10
8	LOOP 12-	LPI2: TB4-12
9	LOOP 13+	LPI2: TB8-1
10	LOOP 13-	LPI2: TB8-3
11	LOOP 14+	LPI2: TB8-4
12	LOOP 14-	LPI2: TB8-6
13	LOOP 15+	LPI2: TB8-7
14	LOOP 15-	LPI2: TB8-9
15	LOOP 16+	LPI2: TB8-10
16	LOOP 16-	LPI2: TB8-12
17	----	
18	----	
19	----	
20	----	

DET. LOOPS 1-8 (J14) C/C 33284G2

PIN	SIGNAL	TO
1	LOOP 1+	LPI1:TB1-1
2	LOOP 1-	LPI1: TB1-3
3	LOOP 2+	LPI1: TB1-4
4	LOOP 2-	LPI1: TB1-6
5	LOOP 3+	LPI1: TB1-7
6	LOOP 3-	LPI1: TB1-9
7	LOOP 4+	LPI1: TB1-10
8	LOOP 4-	LPI1: TB1-12
9	LOOP 5+	LPI1: TB5-1
10	LOOP 5-	LPI1: TB5-3
11	LOOP 6+	LPI1: TB5-4
12	LOOP 6-	LPI1: TB5-6
13	LOOP 7+	LPI1: TB5-7
14	LOOP 7-	LPI1: TB5-9
15	LOOP 8+	LPI1: TB5-10
16	LOOP 8-	LPI1: TB5-12
17	PMT. DET. CH. C	LPI1: TB9-1
18	PMT. DET. CH. D	LPI1: TB9-2
19	KEY PIN	
20	PMT. CH. C/D +26VDC	LPI1: TB9-3
21	PMT. DC GROUND	LPI1: TB9-4,7
22	PMT. CH. A/B +26VDC	LPI1: TB9-8
23	PMT. DET. CH. A	LPI1: TB9-9
24	PMT. DET. CH. B	LPI1: TB9-10
25	----	
26	----	

DET. RACK POWER C/C 171-1083-515			
P1/ DR:J13	P2/ DR:J17	FUNCTION	TO
1		+12 VDC (DET. POWER)	PB-3
2		+24 VDC (BIU POWER)	PB-2
3		LOGIC GROUND	PB-1
4		EARTH GROUND	PB-9
5		"KEY PIN"	
6		LINE FREQUENCY REF.	PB-5
	1	EARTH GROUND	----
	2	AC LINE	PB-12
	3	AC NEUTRAL	PB-10
	4	LOGIC GROUND	----

EXPANSION OUTPUTS C/C 33284G8		
J16	FUNCTION	TO
17	DET. 17 / PMT. A OUT	MP:B19
18	DET. 18 / PMT. B OUT	MP:B20
19	PMT. C OUT	MP:B17
20	PMT. D OUT	MP:B18

DETECTOR LOOP INTERFACE

DETECTOR LOOP
INTERFACE #2
ASSY. 34040G1

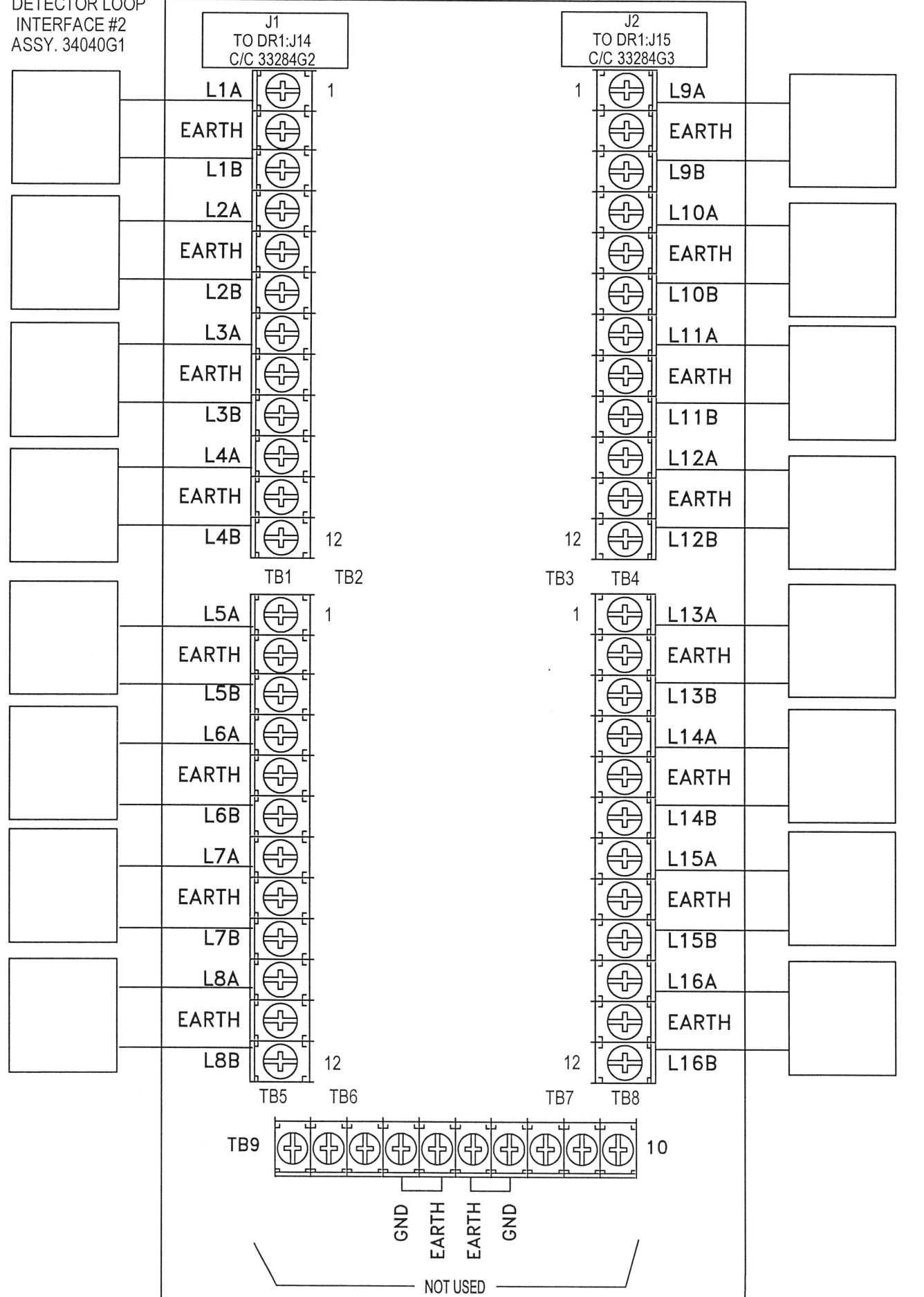

DET. LOOPS 9-16 (J15)		C/C 33284G3
PIN	SIGNAL	TO
1	LOOP 9+	LPI2:TB1-1
2	LOOP 9-	LPI2: TB1-3
3	LOOP 10+	LPI2: TB1-4
4	LOOP 10-	LPI2: TB1-6
5	LOOP 11+	LPI2: TB1-7
6	LOOP 11-	LPI2: TB1-9
7	LOOP 12+	LPI2: TB1-10
8	LOOP 12-	LPI2: TB1-12
9	LOOP 13+	LPI2: TB2-1
10	LOOP 13-	LPI2: TB2-3
11	LOOP 14+	LPI2: TB2-4
12	LOOP 14-	LPI2: TB2-6
13	LOOP 15+	LPI2: TB2-7
14	LOOP 15-	LPI2: TB2-9
15	LOOP 16+	LPI2: TB2-10
16	LOOP 16-	LPI2: TB2-12
17	----	
18	----	
19	----	
20	----	

DET. LOOPS 1-8 (J14)		C/C 33284G2
PIN	SIGNAL	TO
1	LOOP 1+	LPI1:TB1-1
2	LOOP 1-	LPI1: TB1-3
3	LOOP 2+	LPI1: TB1-4
4	LOOP 2-	LPI1: TB1-6
5	LOOP 3+	LPI1: TB1-7
6	LOOP 3-	LPI1: TB1-9
7	LOOP 4+	LPI1: TB1-10
8	LOOP 4-	LPI1: TB1-12
9	LOOP 5+	LPI1: TB2-1
10	LOOP 5-	LPI1: TB2-3
11	LOOP 6+	LPI1: TB2-4
12	LOOP 6-	LPI1: TB2-6
13	LOOP 7+	LPI1: TB2-7
14	LOOP 7-	LPI1: TB2-9
15	LOOP 8+	LPI1: TB2-10
16	LOOP 8-	LPI1: TB2-12
17	PMT. DET. CH. A	LPI1: TB3-1
18	PMT. DET. CH. B	LPI1: TB3-2
19	KEY PIN	
20	PMT. CH. A/B +26VDC	LPI1: TB3-3
21	PMT. DC GROUND	LPI1: TB3-4,7
22	PMT. CH. C/D +26VDC	LPI1: TB3-8
23	PMT. DET. CH. C	LPI1: TB3-9
24	PMT. DET. CH. D	LPI1: TB3-10
25	----	
26	----	

DET. RACK POWER C/C 171-1083-515			
P1/ DR:J13	P2/ DR:J17	FUNCTION	TO
1		+12 VDC (DET. POWER)	PB-3
2		+24 VDC (BIU POWER)	PB-2
3		LOGIC GROUND	PB-1
4		EARTH GROUND	PB-9
5		"KEY PIN"	
6		LINE FREQUENCY REF.	PB-5
	1	EARTH GROUND	----
	2	AC LINE	PB-12
	3	AC NEUTRAL	PB-10
	4	LOGIC GROUND	----

DETECTOR LOOP INTERFACE

B.I.U	DET	PH	F	DET	DLY	EXT	DET	PH	F	DET	DLY	EXT	DET	PH	F	DET	DLY	EXT	DET	PH	F	DET	DLY	EXT	EVP	PH	POLE #	CONT CH #
	CH 1	1	1	1-1			CH 5	2	1	2-1			CH 9	4	3/8	4-1			CH 13	8	3/8	8-1			CH 1	1-6	1	3
	CH 2	1	1	1-2			CH 6	2	1	2-2			CH 10	4	7	4-2	10.0		CH 14	8	7	8-2	10.0		CH 2	2-5	3	4
	CH 3	5	1	5-1			CH 7	6	1	6-1			CH 11	4	7	4-3	2.0		CH 15	8	7	8-3	2.0		CH 3	8	2	5
	CH 4	5	1	5-2			CH 8	6	1	6-2			CH 12						CH 16						CH 4	4	4	6
B.I.U	DET	PH	F	DET	DLY	EXT	DET	PH	F	DET	DLY	EXT	DET	PH	F	DET	DLY	EXT	DET	PH	F	DET	DLY	EXT				
	CH 17						CH 21						CH 25						CH 29									
	CH 18						CH 22						CH 26						CH 30									
	CH 19						CH 23						CH 27						CH 31									
	CH 20						CH 24						CH 28						CH 32									

EVP SENSORS

CABLE	DISCR. CHAN.	PHASES	POLE#	TERMINAL TB9		
				SIGNAL	DC(+)	GND
40	1	1-6	1	9	8	7
29	2	2-5	3	10	8	7
16	3	8	2	1	3	4
49	4	4	4	2	3	4

VEHICLE SIGNALS

CABLE	SIGNAL	TERMINAL						
		G	FLA	Y	R	G	Y	R
	1-1	1		5	7			
	1-2	2		6	8			
	2-1,2-3					9	11	13
	2-2					10	12	14
	4-1,4-3					23	25	27
	4-2					24	26	28
	5-1	29	31	33	35			
	5-2	30	32	34	36			
	6-1,6-3					37	39	41
	6-2					38	40	42
	8-1,8-3					51	53	55
	8-2					52	54	56

VEH DETECTORS

CABLE	DET	SLOT	FUNC	RACK	TERMINAL
21	1-1	1	1	1	L1
22	1-2	2	1	1	L2
50	2-1	5	1	1	L5
51	2-2	6	1	1	L6
10	4-1	9	3/8	1	L9
8	4-2	10	7	1	L10
9	4-3	11	7	1	L11
42	5-1	3	1	1	L3
43	5-2	4	1	1	L4
19	6-1	7	1	1	L7
20	6-2	8	1	1	L8
33	8-1	12	3/8	1	L12
31	8-2	14	7	1	L14
32	8-3	15	7	1	L15

PED PUSHBUTTONS

CABLE	PPB	TERMINAL	RETURN
46	2-1	PC2	GB1
26	2-2	PC2	GB1
37	4-1	PC4	GB1
47	4-2	PC4	GB1
13	6-1	PC6	GB1
38	6-2	PC6	GB1
27	8-1	PC8	GB1
14	8-2	PC8	GB1

PED SIGNALS

CABLE	SIGNAL	TERMINAL	
		WK	DW
44	2-1	57	61
24	2-2	58	62
35	4-1	63	67
44	4-2	64	68
11	6-1	69	73
35	6-2	70	74
24	8-1	75	79
11	8-2	76	80

EVP VERIFY LIGHTS

CABLE	CONTR CHAN.	PHASES	POLE#	TERM.
39	3	1-6	1	59
28	4	2-5	3	65
15	5	8	2	71
48	6	4	4	77