

MAIN PANEL:171-1081-504

ASC3-2100 CONTROLLER WITH:	LEGEND																																										
<ul style="list-style-type: none"> ■ CONFIGURATION: 3601 ■ SOFTWARE: 2.44.30 ■ ETHERNET MODULE □ OVERLAPS <ul style="list-style-type: none"> □ IN EEPROM □ KEYBOARD ENTERED □ ANALOG TELEMETRY MOD.: 100-1005-501 ■ INTERNAL RS-232 TELEMETRY □ TEST INPUT A = □ TEST INPUT B = 	<table border="0"> <tr> <td>BIU</td> <td>BUS INTERFACE UNIT</td> </tr> <tr> <td>BU()</td> <td>C/C, BIU ()</td> </tr> <tr> <td>CB()</td> <td>CIRCUIT BREAKER ()</td> </tr> <tr> <td>C/C</td> <td>CONNECTING CABLE</td> </tr> <tr> <td>CCA</td> <td>CONTROLLER CABLE "A"</td> </tr> <tr> <td>CDP</td> <td>C/C, DR POWER</td> </tr> <tr> <td>CMA</td> <td>MMU/CMU CABLE "A"</td> </tr> <tr> <td>CMB</td> <td>MMU/CMU CABLE "B"</td> </tr> <tr> <td>CPO</td> <td>C/C PRE-EMPT OUTPUTS</td> </tr> <tr> <td>CPP</td> <td>C/C PRE-EMPT POWER</td> </tr> <tr> <td>DR</td> <td>DETECTOR RACK</td> </tr> <tr> <td>DS()</td> <td>DOOR SWITCH ()</td> </tr> <tr> <td>FL()</td> <td>FLASHER ()</td> </tr> <tr> <td>FR()</td> <td>FLASH XFER. RELAY</td> </tr> <tr> <td>LS()</td> <td>LOAD SWITCH</td> </tr> <tr> <td>MC</td> <td>MERCURY CONTACTOR</td> </tr> <tr> <td>MP</td> <td>MAIN PANEL</td> </tr> <tr> <td>PAP</td> <td>POWER-AUX PANEL</td> </tr> <tr> <td>PSP</td> <td>CAB. PWR. SUPPLY</td> </tr> <tr> <td>SA</td> <td>SURGE ARRESTOR</td> </tr> <tr> <td>TB-()</td> <td>TERM. BLOCK ()</td> </tr> </table>	BIU	BUS INTERFACE UNIT	BU()	C/C, BIU ()	CB()	CIRCUIT BREAKER ()	C/C	CONNECTING CABLE	CCA	CONTROLLER CABLE "A"	CDP	C/C, DR POWER	CMA	MMU/CMU CABLE "A"	CMB	MMU/CMU CABLE "B"	CPO	C/C PRE-EMPT OUTPUTS	CPP	C/C PRE-EMPT POWER	DR	DETECTOR RACK	DS()	DOOR SWITCH ()	FL()	FLASHER ()	FR()	FLASH XFER. RELAY	LS()	LOAD SWITCH	MC	MERCURY CONTACTOR	MP	MAIN PANEL	PAP	POWER-AUX PANEL	PSP	CAB. PWR. SUPPLY	SA	SURGE ARRESTOR	TB-()	TERM. BLOCK ()
BIU	BUS INTERFACE UNIT																																										
BU()	C/C, BIU ()																																										
CB()	CIRCUIT BREAKER ()																																										
C/C	CONNECTING CABLE																																										
CCA	CONTROLLER CABLE "A"																																										
CDP	C/C, DR POWER																																										
CMA	MMU/CMU CABLE "A"																																										
CMB	MMU/CMU CABLE "B"																																										
CPO	C/C PRE-EMPT OUTPUTS																																										
CPP	C/C PRE-EMPT POWER																																										
DR	DETECTOR RACK																																										
DS()	DOOR SWITCH ()																																										
FL()	FLASHER ()																																										
FR()	FLASH XFER. RELAY																																										
LS()	LOAD SWITCH																																										
MC	MERCURY CONTACTOR																																										
MP	MAIN PANEL																																										
PAP	POWER-AUX PANEL																																										
PSP	CAB. PWR. SUPPLY																																										
SA	SURGE ARRESTOR																																										
TB-()	TERM. BLOCK ()																																										

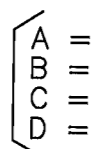

MAIN PANEL PLUG-IN REQUIREMENTS

BIU2 T&F	BIU3 T&F	LS9 PED 2 BEACONS	LS10 PED 4 BEACONS	LS11 PED 6 BEACONS	LS12 PED 8 BEACONS	LS13 OL "A"	LS14 OL "B"	LS15 OL "C"	LS16 OL "D"
BIU1 T&F	LS1 VEH 1	LS2 VEH 2	LS3 VEH 3	LS4 VEH 4	LS5 VEH 5	LS6 VEH 6	LS7 VEH 7	LS8 VEH 8	FL1 □1CKT ■2CKT
FR1 L R V1 V5	FR2 L R V2 V6	FR3 L R V3 V7	FR4 L R V4 V8	⊗FR5 L R A C	⊗FR6 L R B D	K1 LS 24V CONT.			

■ DENOTES TYPE OF OPERATION AND/OR WHERE PLUG-IN IS REQUIRED. L = LEFT, R = RIGHT.
 ⊗ DENOTES WHERE "UNUSED RED" JUMPER PART NUMBER 32448G1 IS REQUIRED. INSTALL BETWEEN PINS 1 & 3 FOR LOAD SWITCH OR PINS 6 & 8 AND 5 & 7 FOR FLASH TRANSFER RELAY.

FLASH:
 □ ø2&6 YELLOW, ALL OTHERS RED.
 ■ ALL RED.
 ■ RELAYS DE-ENERGIZED FOR FLASH.
 □ RELAYS ENERGIZED FOR FLASH.

FLASHER	
PIN	FUNCTION
7	CIRCUIT #1
8	CIRCUIT #2
9	CHASSIS GND
10	AC COMMON
11	115 VAC
12	-----

LOAD SWITCH	
PIN	FUNCTION
1	115 VAC
2	CHASSIS GND
3	RED/DW OUTPUT
4	-----
5	YEL OUTPUT
6	RED/DW INPUT
7	GRN/W OUTPUT
8	YEL INPUT
9	+24 VDC
10	GRN/W INPUT
11	AC COMMON
12	-----

Ⓢ 2.2K
10W

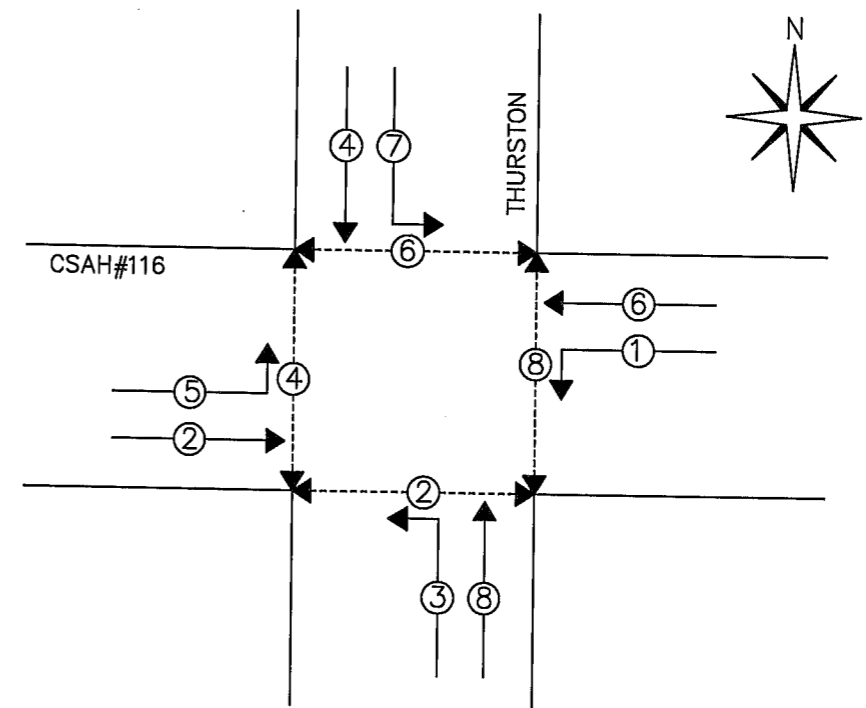

SHEET 1 OF 12

3 USE ONLY COPPER CONDUCTORS FOR FIELD AND SERVICE CONNECTIONS.

2 CONNECT A.C. SERVICE TO TERMINAL BLOCK 501 (LINE), 502 (NEUTRAL) AND GB2 (EARTH) ON RIGHT SIDEWALL OF CABINET.

Ⓢ INSTALL 2.2K, 10 WATT LOAD RESISTORS BETWEEN PINS 7 AND 11 ON LOAD SWITCHES 9, 10, 11 & 12.

NOTES: UNLESS SPECIFIED OTHERWISE

DESIGNER G.V. T.C.C.	DATE 02/03/97	ECONOLITE CONTROL PRODUCTS INC.	TRAFFIC CONTROL CORPORATION 780 W. BELDEN SUITE D ADDISON, IL 60101
DRAWN CM TCC	DATE 11/04/08		
CABINET SIZE 77" HOFFMAN GRAY	CABINET SPECIFICATION: TS2TYPE1 ANOKA COUNTY SPEC PLUG AND GO		CONTROLLER
INSPECTED	CUSTOMER: INTERSECTION: CSAH#116 AT THURSTON		FLASHER
APPROVED	LOCATION: SYSTEM:		SW.PACKS
CUSTOMER P.O. SIG783-09-05	INSTALLED BY	SALES ORDER NO.	SIZE B
			DRAWING #TS2AC16PG-

POLICE/AUX SWITCHES
ASSY. NO. 171-1078-510

POLICE/AUXILIARY SWITCH PANEL		
J1 PIN	FUNCTION	TO
A1	FILTER AC LINE (IN)	SW1-2
A2	SWITCHED AC LINE (OUT)	SW1-3
A3	FLASH CONTROL BUS (IN)	SW2-2
A4	SIGNAL BUS CONTROL (OUT)	SW5-5
A5	FLASH RELAY CONT. (OUT)	SW5-2
A6	START DELAY BUS (OUT)	SW1-3
B1	MMU FLSH CONT. BUS (OUT)	SW1-3
B2	SPARE	---
B3	SPARE	---
B4	SPARE	---
B5	SPARE	---
B6	SPARE	---
C1	MAN. CONT. ENABLE (OUT)	SW6-1
C2	LOGIC GROUND	SW3-1
C3	INTERVAL ADVANCE (OUT)	T2-B
C4	MMU STOP TIME (IN)	SW3-3
C5	CONT. STOP TIME (OUT)	SW3-2
C6	LOCAL FLASH STATUS (OUT)	SW2-5
D1	COORD FREE (OUT)	---
D2	ALARM 1 (OUT)	---
D3	ALARM 2 (OUT)	---
D4	LOADSWITCH TEST (OUT)	---
D5	MMU 24 VOLT MON. 2 (OUT)	---
D6	+24 VDC (IN)	---

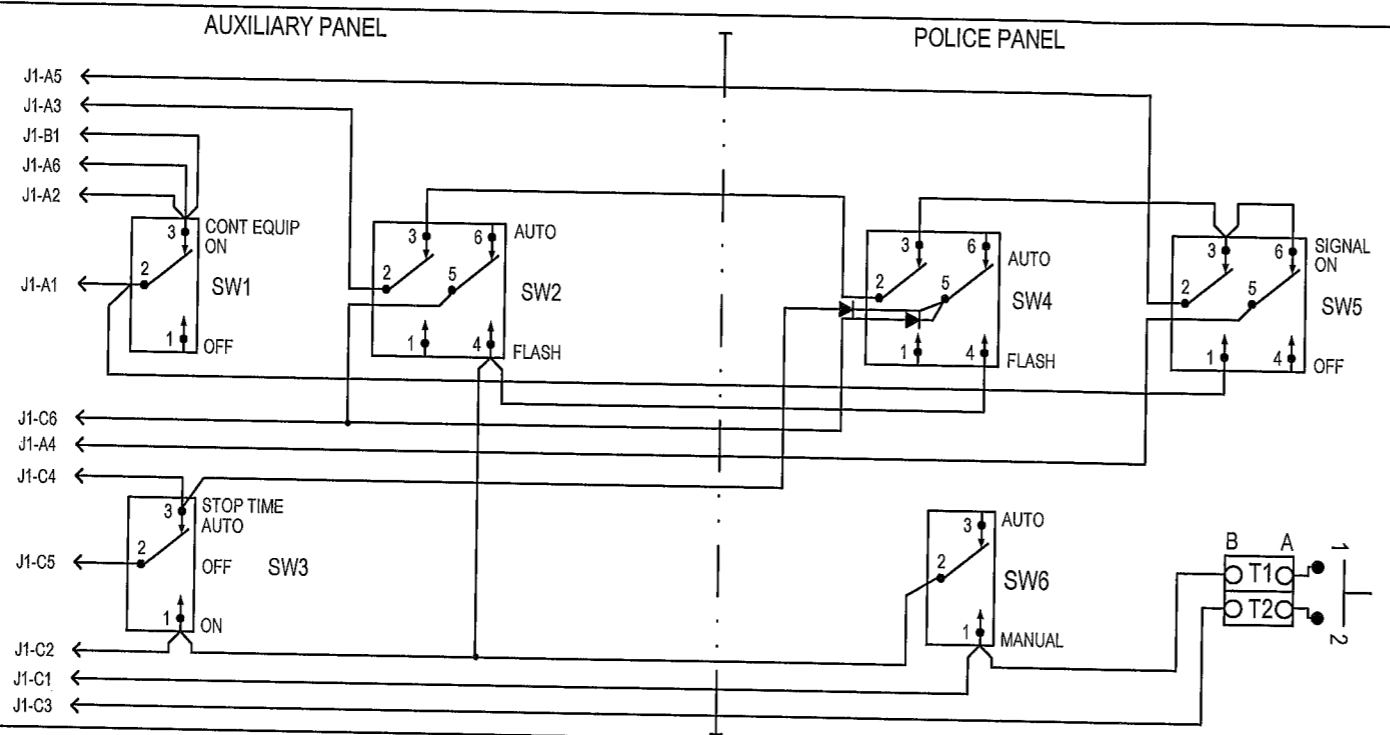

POWER/AUX PANEL (PAP)
PS4-001

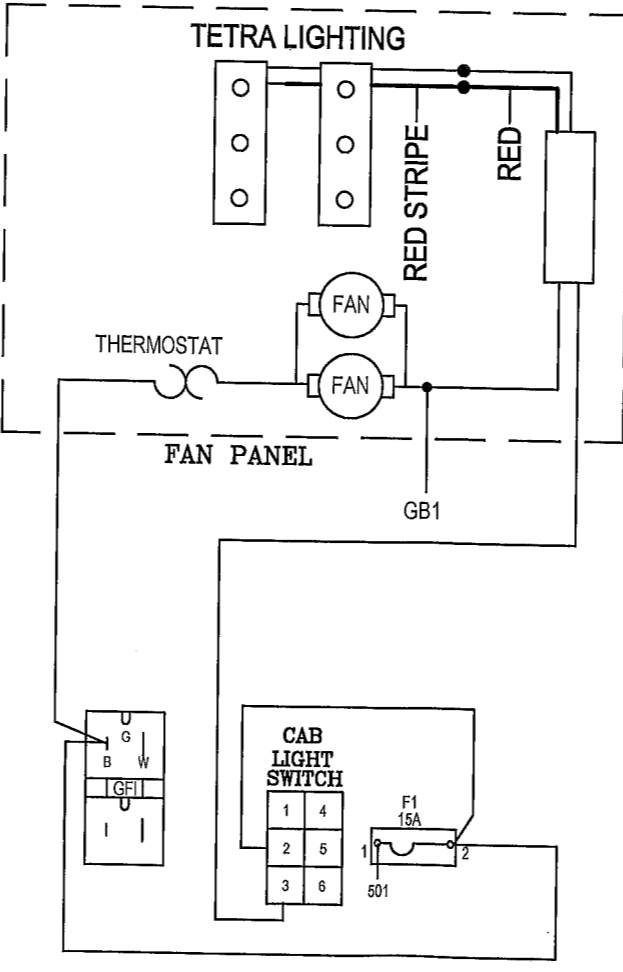
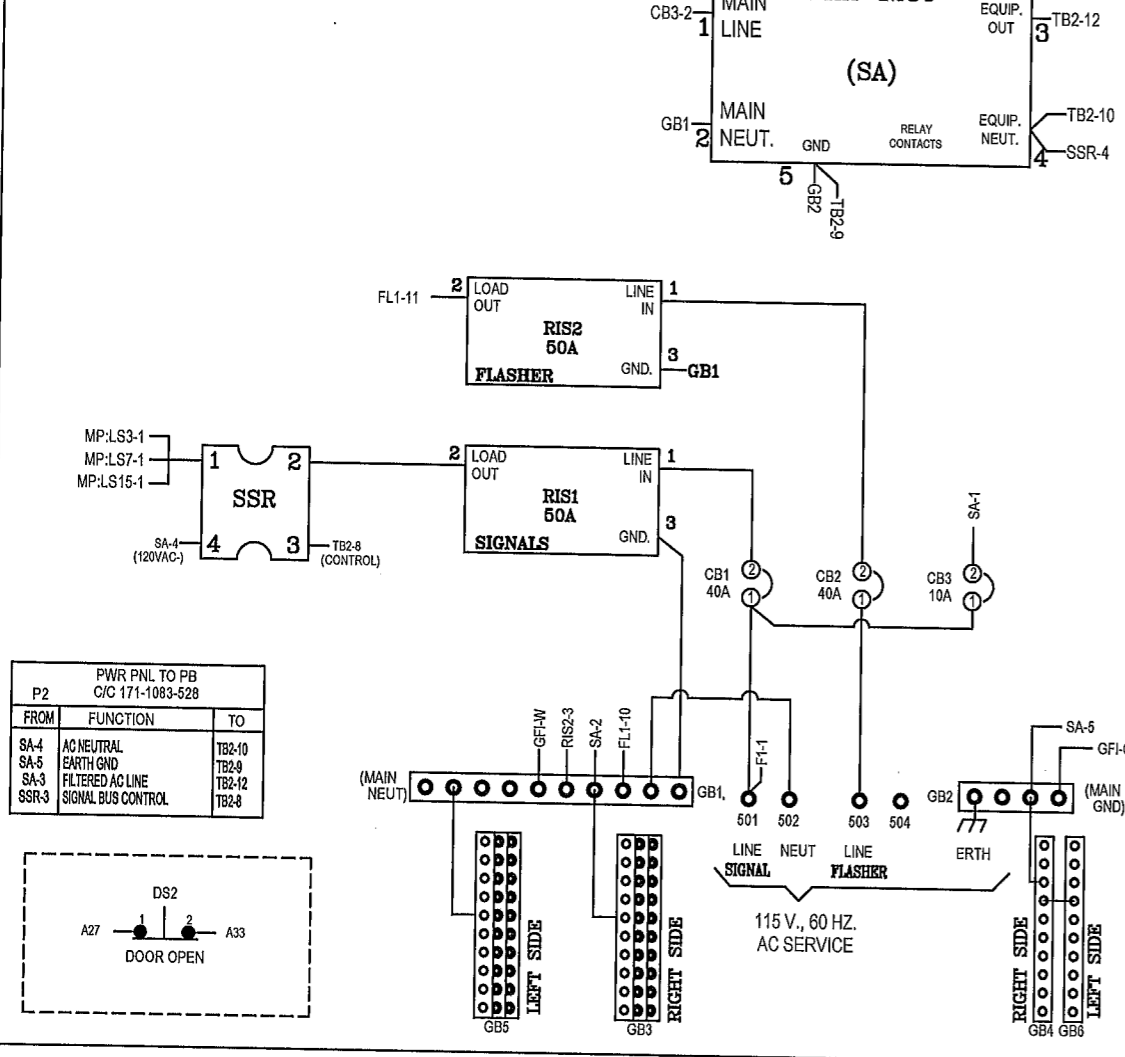

J3-D6 A1
MMB-1 A2
MMA-37 A3
K1-10 A4
FR6-2 A5
MMB-2 A6
MMA-20 A7
A8
A9
A10
B1
B2
A-39 B3
A-35 B4
A-40 B5
A-31 B6
A-30 B7
A-32 B8
A-38 B9
A-33 B10
A-34 C1
K1-9 C2
B-3 C3
B-4 C4
A-35 C5
K1-11 C6
C7
B-5 C8
J1-31B C9
C10
J1-27B D1
K1-10 D2
D3
K1-2 D4
MMB-18 D5
J3-A1 D6

(MAIN PANEL & C/C REFERENCES ONLY)

TO/FROM POLICE-AUXILIARY SWITCH PANEL		
PIN	FUNCTION	TO: POL/AUX ASSY.
A1	FILTER AC LINE (OUT)	A1
A2	SWITCHED AC LINE (IN)	A2
A3	FLASH CONTROL BUS (OUT)	A3
A4	SIGNAL BUS CONTROL (IN)	A4
A5	FLASH RELAY CONTROL (IN)	A5
A6	START DELAY AC BUS (IN)	A6
A7	MMU FLASH CONTROL BUS (IN)	B1
A8	SPARE	B2
A9	SPARE	B3
A10	SPARE	B4
B1	SPARE	B5
B2	SPARE	B6
B3	OPT-MAN. CONT. ENABLE (IN)	C1
B4	LOGIC GROUND	C2
B5	OPT-INTERVAL ADVANCE (IN)	C3
B6	MMU STOP TIME (OUT)	C4
B7	CONTROLLER STOP TIME (IN)	C5
B8	LOCAL FLASH STATUS (IN)	C6
B9	OPT-COORD FREE (IN)	D1
B10	OPT-ALARM 1 (IN)	D2
C1	OPT-ALARM 2 (IN)	D3
C2	OPT-LOADSWITCH TEST (IN)	D4
C3	MMU 24 VOLT MON. 2 (IN)	D5
C4	+24 VDC	D6
PART OF 171-1083-504/524		
TO: PBA		
TO: POL/AUX ASSY.		
MP P3 PIN	MAIN PANEL/CONTROLLER PWR. C/C 171-1083-504/524	TO POL/AUX P1 PIN
C5	LOGIC GROUND	A1
C6	+24 VDC (IN)	A2
C7	---	A3
C8	MMU FAULT MONITOR (IN)	A4
C9	LINE FREQ. REFERENCE (IN)	B1
C10	---	B2
D1	12 VAC (IN)	B3
D2	SIGNAL BUS CONTROL (IN)	B4
D3	---	C1
D4	FILTERED AC NEUTRAL (IN)	C2
D5	CONT. EQUIP. AC LINE (OUT)	C3
D6	FILTERED AC LINE (IN)	C4

CONFIRMATION BEACONS

- EVP 3 = 1-6
- EVP 4 = 2-5
- EVP 5 = 3-8
- EVP 6 = 4-7

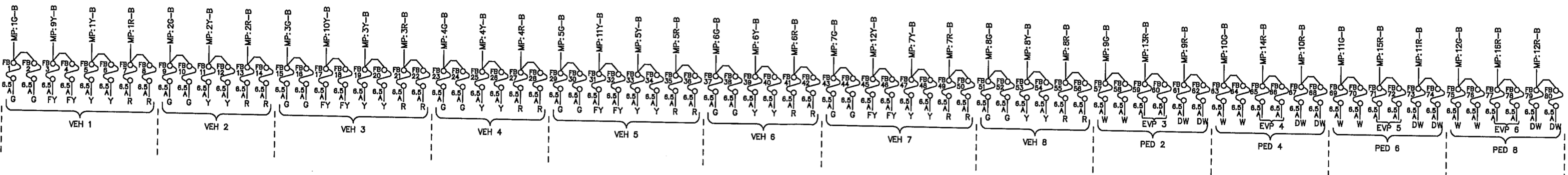
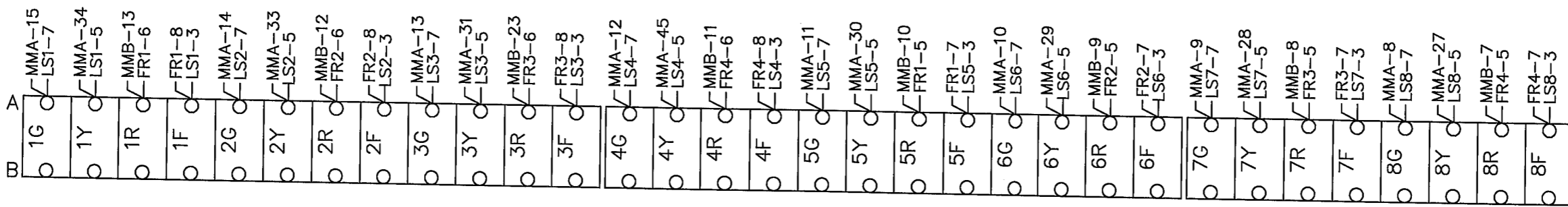
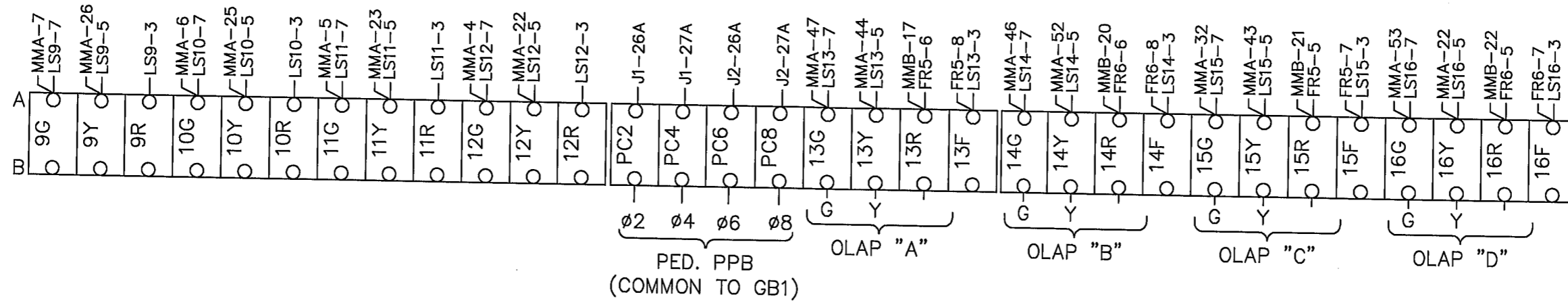

SIGNAL FIELD TERMINALS

①
2.2K
10W

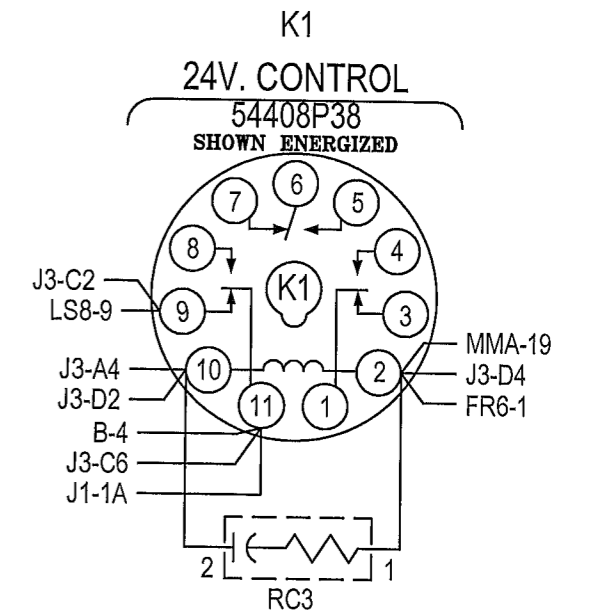
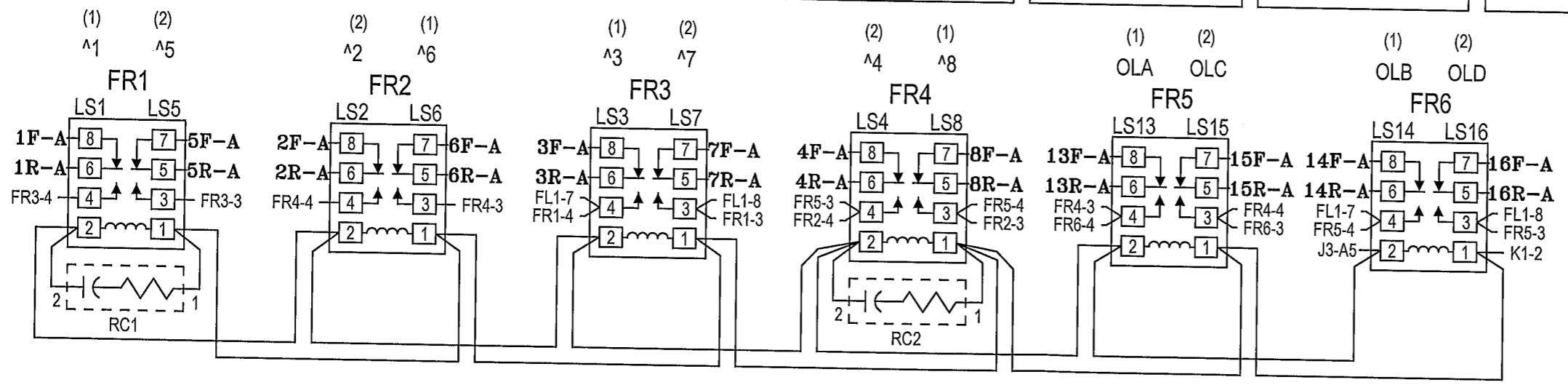
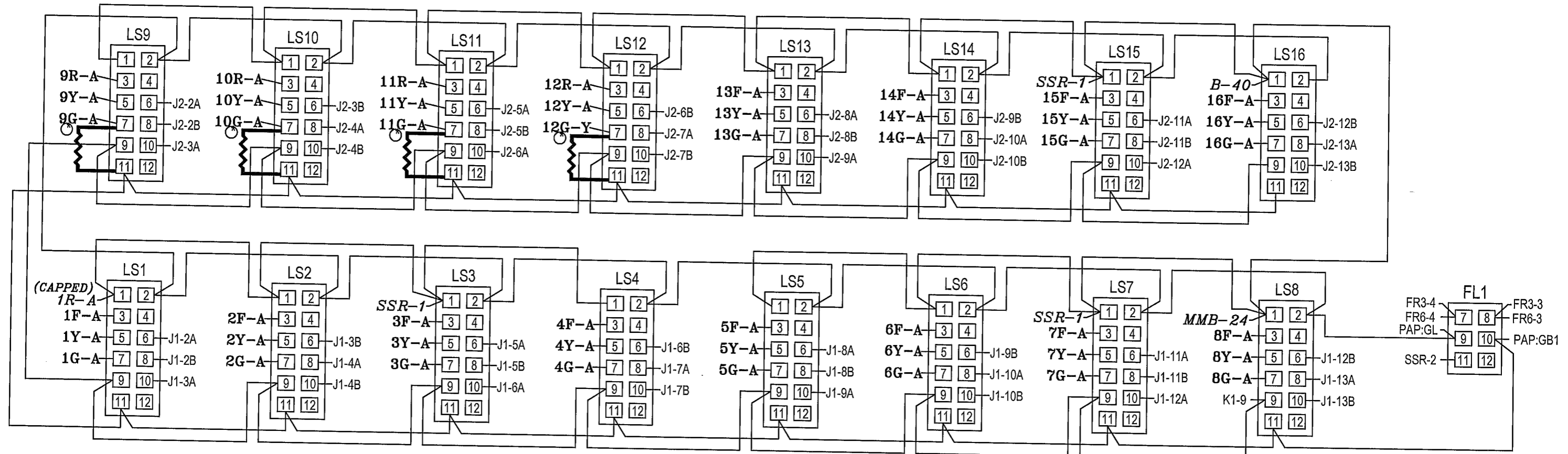

LOADBAY AND FLASH RELAY'S

1	MMU. RESET	MMA-49	J2-21B	RG. 1 INHBT. MAX.
2	24 V. MON. INHBT.	MMA-36	J2-22A	RG. 2 INHBT. MAX.
3	MMU. +24 V. MON. 2	J3-C3	J1-23B	RG. 1 FORCE OFF
4	MMU. +24 V. MON. 1	MMB-15	J1-24A	RG. 2 FORCE OFF
5	FAULT MON.	K1-11 J3-C4 MMA-16 J3-C8	J1-22B	RG. 1 MAX. 2 SEL.
6	PC1 PED. DET. 1	MMA-35	J1-23A	RG. 2 MAX. 2 SEL.
7	PC3 PED. DET. 3	J1-26B	J1-24B	CALL NONACT 1
8	PC5 PED. DET. 5	J2-25B	J2-19A	CALL NONACT 2
9	PC7 PED. DET. 7	J2-26B	J1-25A	WALK REST MDFR.
10	DET. 61	J2-19B	J1-20A	PMT CMU INTLK
11	DET. 62	J2-20A	J1-20B	EXT. START
12	DET. 63	J2-20B	J1-17A	TEST INPUT A
13	DET. 64	J2-21A	J1-17B	TEST INPUT B
14	LOGIC GND.	MMA-17 J1-32A A-20	J2-25A	TEST INPUT C
15	PMT. CALL 1	J1-16A	J1-21A	T.B.C. ON LINE
16	PMT. CALL 2	J1-16B	J1-14A	T.B.C. AUX. 1
17	PMT. CALL 3	J2-17A	J1-14B	T.B.C. AUX. 2
18	PMT. CALL 4	J2-17B	J2-14A	T.B.C. AUX. 3
19	PMT. CALL 5	J2-18A	J2-14B	COORD. STATUS OUT
20	PMT. CALL 6	J2-18B	MMA-55 A-27	LOGIC GND.

J16-19
J16-20
J16-17
J16-18

21	MMA AC+ I IN	MMA-1	J1-15A	PMT. 1 ACTV.
22	DR1 OPEN	MMA-2	J1-15B	PMT. 2 ACTV.
23	DR2 CLSD	MMA-3	J2-15A	ALARM 3
24	MMA SPR 1	MMA-48	J2-15B	ALARM 4
25	CAB INTLK A	MMA-50	J2-16A	ALARM 5
26	CAB INTLK B	MMA-51	J2-16B	ALARM 6
27	MMA SPR 2	MMA-21 MMA-54 A-20 A-35	J1-21 A-20 A-35	LOGIC GND
28	SDR OPEN	MMB-3	DS2-1	LOGIC GND
29	MMB SPR 1	MMB-14	DS2-1	LOGIC GND
30	MMB SPR 2	MMB-16	J1-21B J1-22A J3-B7	STOP TIMING 1 & 2
31	MMB SPR 3	MMB-25	J2-23A J3-B6	MMU STOP TIMING
32		J2-22B	J2-22B	LOCAL FLASH
33		J3-B8	J3-B8	STATUS
34		J2-23B	J2-23B	ALARM 1
35		J3-B10	J3-B10	ALARM 2
36		J2-24A	J2-24A	LOGIC GND
37	AC+	J3-C1	J3-C1	DIM. ENABLE
38	AC+	A-27 J3-C5 J3-B4	J3-C5 J3-B4	AUTO FLASH
39	AC+	J1-18B	J1-18B	COORD. FREE
40	AC+	MMB-6 MMB-19 MMB-5 MMB-4 LS16-1	J1-18A J2-24B J3-B9 J1-19A J3-B3 J1-19B J3-B5	MANUAL CONT. ENABLE INTRVL ADV.

INTERFACE TERMINAL BLOCKS

J1		BIU #1	
PIN	FUNCTION	TO	
1A	+24 VDC	K1-11	
1B	+24 VDC	J2-1B	
2A	LS1 RED	LS1-6	
2B	LS1 YELLOW	LS1-8	
3A	LS1 GREEN	LS1-10	
3B	LS2 RED	LS2-6	
4A	LS2 YELLOW	LS2-8	
4B	LS2 GREEN	LS2-10	
5A	LS3 RED	LS3-6	
5B	LS3 YELLOW	LS3-8	
6A	LS3 GREEN	LS3-10	
6B	LS4 RED	LS4-6	
7A	LS4 YELLOW	LS4-8	
7B	LS4 GREEN	LS4-10	
8A	LS5 RED	LS5-6	
8B	LS5 YELLOW	LS5-8	
9A	LS5 GREEN	LS5-10	
9B	LS6 RED	LS6-6	
10A	LS6 YELLOW	LS6-8	
10B	LS6 GREEN	LS6-10	
11A	LS7 RED	LS7-6	
11B	LS7 YELLOW	LS7-8	
12A	LS7 GREEN	LS7-10	
12B	LS8 RED	LS8-6	
13A	LS8 YELLOW	LS8-8	
13B	LS8 GREEN	LS8-10	
14A	TBC AUX 1	A-16	
14B	TBC AUX 2	A-17	
15A	PMT ACT 1	A-21	
15B	PMT ACT 2	A-22	
16A	PMT CALL 1	B-15	
16B	PMT CALL 2	B-16	
17A	TEST A	A-12	
17B	TEST B	A-13	
18A	AUTO FLASH	A-37	
18B	DIM. ENABLE	A-36	
19A	MANUAL CONT.	A-39	
19B	INT. ADVANCE	A-40	
20A	PMT CMU INTLK	A-10	
20B	EXT. START	A-11	
21A	TBC ONLINE	A-15	
21B	STOP TIME (1)	A-30	
22A	STOP TIME (2)	A-30	
22B	MAX. 2 (1)	A-5	
23A	MAX. 2 (2)	A-6	
23B	FORCE OFF (1)	A-3	
24A	FORCE OFF (2)	A-4	
24B	CNA 1	A-7	
25A	WALK REST MOD.	A-9	
25B	PED. ISO. 1	B-6	
26A	PED. ISO. 2	PC2-A	
26B	PED. ISO. 3	B-7	
27A	PED. ISO. 4	PC4-A	
27B	PED. ISO. COMN.	J3-D1	
28A	ADDR. SEL. 0	-----	
28B	ADDR. SEL. 1	-----	
29A	ADDR. SEL. 2	-----	
29B	ADDR. SEL. 3	-----	
30A	RESERVED	-----	
30B	RESERVED	-----	
31A	EARTH GND.	LS12-2	
31B	LINE FREQ. REF.	J3-C9	
32A	LOGIC GND.	B-14	
32B	LOGIC GND.	J2-32A	

J2		BIU #2	
PIN	FUNCTION	TO	
1A	+24 VDC	J2-1B	
1B	+24 VDC	J1-1B	
2A	LS9 RED	LS9-6	
2B	LS9 YELLOW	LS9-8	
3A	LS9 GREEN	LS9-10	
3B	LS10 RED	LS10-6	
4A	LS10 YELLOW	LS10-8	
4B	LS10 GREEN	LS10-10	
5A	LS11 RED	LS11-6	
5B	LS11 YELLOW	LS11-8	
6A	LS11 GREEN	LS11-10	
6B	LS12 RED	LS12-6	
7A	LS12 YELLOW	LS12-8	
7B	LS12 GREEN	LS12-10	
8A	LS13 RED	LS13-6	
8B	LS13 YELLOW	LS13-8	
9A	LS13 GREEN	LS13-10	
9B	LS14 RED	LS14-6	
10A	LS14 YELLOW	LS14-8	
10B	LS14 GREEN	LS14-10	
11A	LS15 RED	LS15-6	
11B	LS15 YELLOW	LS15-8	
12A	LS15 GREEN	LS15-10	
12B	LS16-RED	LS16-6	
13A	LS16-YELLOW	LS16-8	
13B	LS16-GREEN	LS16-10	
14A	TBC AUX 3	A-18	
14B	COORD. STATUS	A-19	
15A	ALARM 3	A-23	
15B	ALARM 4	A-24	
16A	ALARM 5	A-25	
16B	ALARM 6	A-26	
17A	PMT CALL 3	B-17	
17B	PMT CALL 4	B-18	
18A	PMT CALL 5	B-19	
18B	PMT CALL 6	B-20	
19A	CNA 2	A-8	
19B	VEH. DET. 61	B-10	
20A	VEH. DET. 62	B-11	
20B	VEH. DET. 63	B-12	
21A	VEH. DET. 64	B-13	
21B	INHIBIT MAX (1)	A-1	
22A	INHIBIT MAX (2)	A-2	
22B	LOCAL FLASH	A-32	
23A	MMU FLASH	A-31	
23B	ALARM 1	A-33	
24A	ALARM 2	A-34	
24B	COORD FREE IN	A-38	
25A	TEST C	A-14	
25B	PED. ISO. 5	B-8	
26A	PED. ISO. 6	PC6-A	
26B	PED. ISO. 7	B-9	
27A	PED. ISO. 8	PC8-A	
27B	PED. ISO. COMN.	J1-27B	
28A	ADDR. SEL. 0	J2-32A	
28B	ADDR. SEL. 1	-----	
29A	ADDR. SEL. 2	-----	
29B	ADDR. SEL. 3	-----	
30A	RESERVED	-----	
30B	RESERVED	-----	
31A	EARTH GND.	J1-31A	
31B	LINE FREQ. REF.	J1-31B	
32A	LOGIC GND.	J1-32B	
32B	LOGIC GND.	J2-32A	

MAIN PANEL CONTROL POWER C/C 171-1083-504	
PIN	FUNCTION
A1	LOGIC GND
A2	+24 VDC (IN)
A3	----
A4	MMU FAULT MONITOR (IN)
B1	LINE FREQ. REFERENCE (IN)
B2	----
B3	+12 VAC (IN)
B4	SIGNAL BUS CONTROL (IN)
C1	----
C2	FILTERED AC NEUTRAL (IN)
C3	CONT. EQUIP. AC LINE (OUT)
C4	FILTERED AC LINE (IN)

CONTROLLER POWER (CCA2) C/C 171-1083-503			
WIRE	PIN	SIGNAL	TO
1	A	FAULT MONITOR	PB-4
2	U	AC NEUTRAL	PB-10
3	V	EARTH GROUND	PB-9
4	W	LOGIC GROUND	PB-1
5	P	AC LINE	PB-11
6	SHL	EARTH GROUND	CCA2-V

TYPE 1 CONTROLLER POWER C/C 171-1083-502		
PIN	FUNCTION	TO
A	AC NEUTRAL	PB-10
B	----	----
C	AC LINE	PB-11
D	----	----
E	+	+
F	FAULT MON.	PB-4
G	LOGIC GND.	PB-1
H	EARTH GND.	PB-9
I	----	----
J	----	----
SHL	EARTH GND.	PIN H

CABINET POWER SUPPLY C/C 171-1083-511		
PIN	FUNCTION	TO
A	AC NEUTRAL	PB-10
B	LINE FREQUENCY REF.	PB-5
C	AC LINE	PB-11
D	+12 VDC	PB-3
E	+24 VDC	PB-2
F	RESERVED	----
G	LOGIC GND.	PB-1
H	EARTH GND.	PB-9
I	+12 VAC	PB-7
J	RESERVED	----
SHL	EARTH GND.	PIN H

CONTROLLER PORT 1 CONNECTOR			
PIN	SIGNAL	TO	FUNCTION
1	TWISTED PAIR 1+	SDLC-1	CONT TXD+
2	LOGIC GND.	----	----
3	TWISTED PAIR 2+	SDLC-4	CONT TXC+
4	LOGIC GND.	----	----
5	TWISTED PAIR 3+	SDLC-7	CONT RXD+
6	LOGIC GND.	----	----
7	TWISTED PAIR 4+	SDLC-10	CONT RXC+
8	LOGIC GND.	----	----
9	TWISTED PAIR 1-	SDLC-2	CONT TXD-
10	PORT 1 DISABLE	----	----
11	TWISTED PAIR 2-	SDLC-5	CONT TXC-
12	EARTH GND.	SHIELD WIRE	----
13	TWISTED PAIR 3-	SDLC-8	CONT RXD-
14	RESERVED	----	----
15	TWISTED PAIR 4-	SDLC-11	CONT RXC-

MMU & BIU PORT 1 CONNECTOR			
PIN	SIGNAL	TO	FUNCTION
1	TWISTED PAIR 1+	SDLC-1	BIU RXD+
2	LOGIC GND.	----	----
3	TWISTED PAIR 2+	SDLC-4	BIU RXC+
4	LOGIC GND.	----	----
5	TWISTED PAIR 3+	SDLC-7	BIU TXD+
6	LOGIC GND.	----	----
7	TWISTED PAIR 4+	SDLC-10	BIU TXC+
8	LOGIC GND.	----	----
9	TWISTED PAIR 1-	SDLC-2	BIU RXD-
10	PORT 1 DISABLE	----	----
11	TWISTED PAIR 2-	SDLC-5	BIU RXC-
12	EARTH GND.	SHIELD WIRE	----
13	TWISTED PAIR 3-	SDLC-8	BIU TXD-
14	RESERVED	----	----
15	TWISTED PAIR 4-	SDLC-11	BIU TXC-

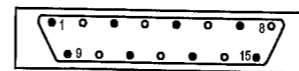

FRONT VIEW OF BU1 - BU5

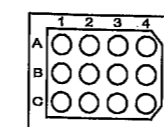

FRONT VIEW OF J1-J6

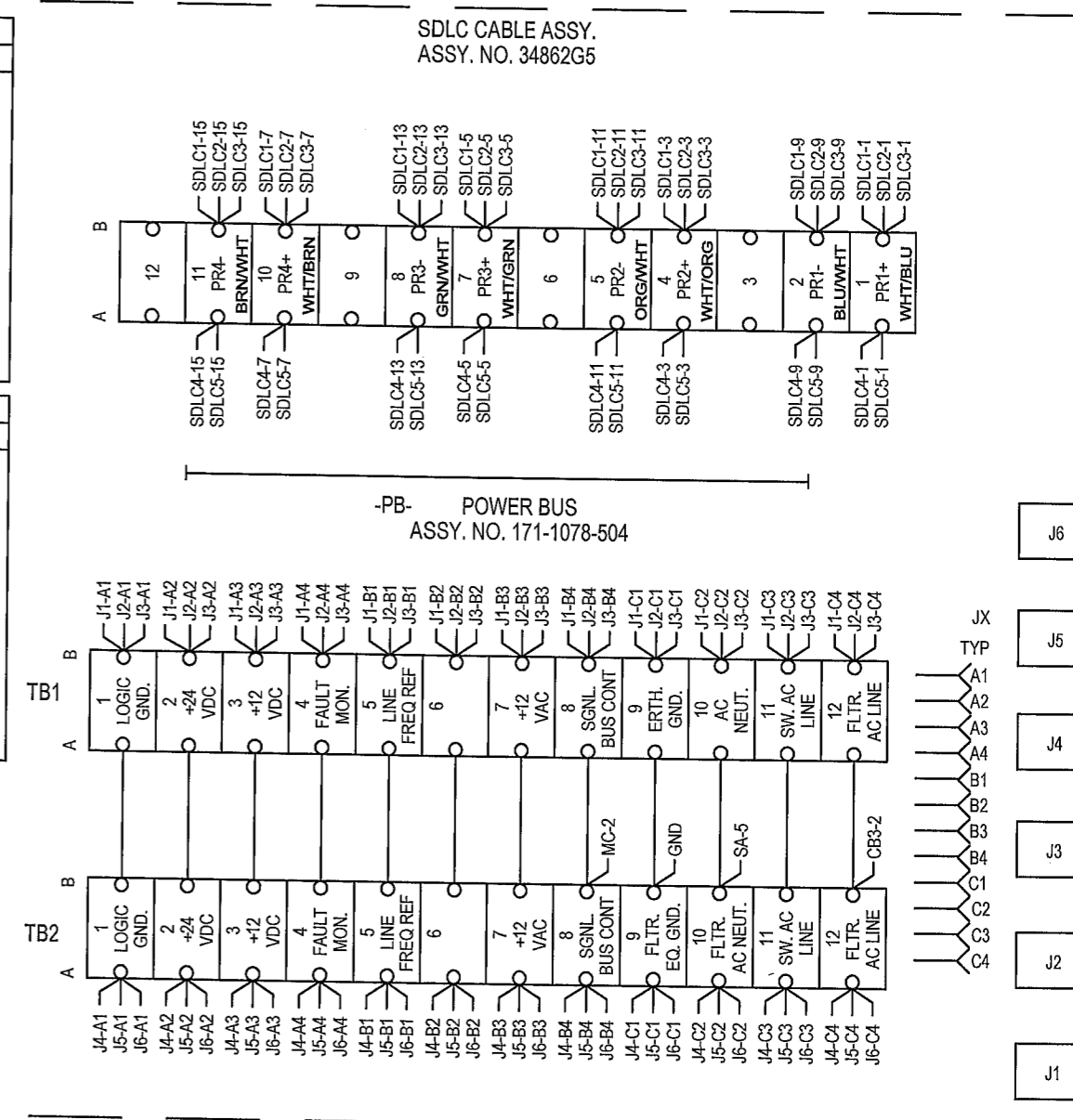

BIU AND CONNECTING CABLES

WIRE LIST FOR NEMA MALFUNCTION MANAGEMENT UNIT

CONNECTOR "A" (MMA)					CONNECTOR "B" (MMB)				
PIN	WIRE	MON. FUNCTION	TO	SIG. FUNCTION	PIN	WIRE	MON. FUNCTION	TO	SIG. FUNCTION
A	A-1	AC+ I INPUT	B21		A	B-1	AC+ II INPUT	J3-A2	MMU POWER
B	A-2	OUT RLY 1 OPEN	B22		B	B-2	S. DLY RLY COMM.	J3-A6	MMU POWER
C	A-3	OUT RLY 2 CLSD	B23		C	B-3	S. DLY RLY OPEN	B28	
D	A-4	CH. 12 GREEN	12G-A	^8 WLK	D	B-4	CH. 12 RED	B40	
E	A-5	CH. 11 GREEN	11G-A	^6 WLK	E	B-5	CH. 11 RED	B39	
F	A-6	CH. 10 GREEN	10G-A	^4 WLK	F	B-6	CH. 9 RED	B37	
G	A-7	CH. 9 GREEN	9G-A	^2 WLK	G	B-7	CH. 8 RED	8R-A	^8 RED
H	A-8	CH. 8 GREEN	8G-A	^8 GRN	H	B-8	CH. 7 RED	7R-A	^7 RED
J	A-9	CH. 7 GREEN	7G-A	^7 GRN	J	B-9	CH. 6 RED	6R-A	^6 RED
K	A-10	CH. 6 GREEN	6G-A	^6 GRN	K	B-10	CH. 5 RED	5R-A	^5 RED
L	A-11	CH. 5 GREEN	5G-A	^5 GRN	L	B-11	CH. 4 RED	4R-A	^4 RED
M	A-12	CH. 4 GREEN	4G-A	^4 GRN	M	B-12	CH. 2 RED	2R-A	^2 RED
N	A-13	CH. 3 GREEN	3G-A	^3 GRN	N	B-13	CH. 1 RED	1R-A	^1 RED
P	A-14	CH. 2 GREEN	2G-A	^2 GRN	P	B-14	(SPARE 1)	B29	
R	A-15	CH. 1 GREEN	1G-A	^1 GRN	R	B-15	+24V MONITOR II	B-3	+24V MON. II
S	A-16	+24V MON. I	B-4	LS +24V MON.	S	B-16	(SPARE 2)	B30	
T	A-17	LOGIC GND	B-14	LOGIC GND	T	B-17	CH. 13 RED	13R-A	OLA RED
U	A-18	CHASSIS GND	LS7-2	EARTH GND.	U	B-18	S. DLY RLY CLSD	J3-D5	CONT. POWER
V	A-19	AC- (COMMON)	K1-2	AC NEUTRAL	V	B-19	CH. 10 RED	B38	
W	A-20	OUT RLY 1 COM.	J3-A7	SIG BUS CONT	W	B-20	CH. 14 RED	14R-A	OLB RED
X	A-21	OUT RLY 2 COM.	A-27	LOGIC GND	X	B-21	CH. 15 RED	15R-A	OLC RED
Y	A-22	CH. 12 YELLOW	12Y-A	VEH. 7 FYA	Y	B-22	CH. 16 RED	16R-A	OLD RED
Z	A-23	CH. 11 YELLOW	11Y-A	VEH. 5 FYA	Z	B-23	CH. 3 RED	3R-A	^3 RED
a	A-24	CH. 10 WALK	----		a	B-24	RED ENABLE	LS8-1	SIG BUS CON.
b	A-25	CH. 10 YELLOW	10Y-A	VEH. 3 FYA	b	B-25	(SPARE 3)	B31	
c	A-26	CH. 9 YELLOW	9Y-A	VEH. 1 FYA	c	B-26	LOCAL FLASH IN	-T-	POL/AX FLSH
d	A-27	CH. 8 YELLOW	8Y-A	^8 YEL		B-27	SHELL GROUND	LS6-2	EARTH GND.
e	A-28	CH. 7 YELLOW	7Y-A	^7 YEL					
f	A-29	CH. 6 YELLOW	6Y-A	^6 YEL					
g	A-30	CH. 5 YELLOW	5Y-A	^5 YEL					
h	A-31	CH. 3 YELLOW	3Y-A	^3 YEL					
i	A-32	CH. 15 GREEN	15G-A	OLC GRN					
j	A-33	CH. 2 YELLOW	2Y-A	^2 YEL					
k	A-34	CH. 1 YELLOW	1Y-A	^1 YEL					
m	A-35	CONT. VOLT. MON.	B-5	VOLT. MON.					
n	A-36	+24V MON. INH.	B-2						
p	A-37	OUT RLY 1 CLSD	J3-A3						
q	A-38	OUT RLY 2 OPEN	A-31	STOP TIME					
r	A-39	CH. 12 WALK	----						
s	A-40	CH. 11 WALK	----						
t	A-41	CH. 9 WALK	----						
u	A-42	CH. 16 YELLOW	16Y-A	OLD YEL					
v	A-43	CH. 15 YELLOW	15Y-A	OLC YEL					
w	A-44	CH. 13 YELLOW	13Y-A	OLA YEL					
x	A-45	CH. 4 YELLOW	4Y-A	^4 YEL					
y	A-46	CH. 14 GREEN	14G-A	OLB GRN					
z	A-47	CH. 13 GREEN	13G-A	OLA GRN					
AA	A-48	(SPARE 1)	B24						
BB	A-49	RESET	B-1						
CC	A-50	CAB. INTLK A	B25						
DD	A-51	CAB. INTLK B	B26						
EE	A-52	CH. 14 YELLOW	14Y-A	OLB YRL					
FF	A-53	CH. 16 GREEN	16G-A	OLD GRN					
GG	A-54	(SPARE 2)	B27						
HH	A-55	TYPE SELECT	A-20	MMU/CMU SEL.					
	A-56	SHELL GND	LS15-2	EARTH GND.					

NOTES FOR 16 CHANNEL M.M.U.

- (1) RELAY CONTACT POSITIONS SPECIFIED ARE FOR NON-CONFLICT MODE.
- (2) TO PROGRAM MMU, SOLDER JUMPERS IN PROGRAMMING CARD FOR ALL PERMISSABLE PHASE MOVEMENTS, MINIMUM CHANGE DISABLE FOR ALL PEDESTRIAN CHANNELS, AND MIN. FLASH, VOLTAGE MON., AND 24V. MON. LATCH OPTIONS AS DESIRED.

M.M.U. CHANNEL ASSIGNMENTS

CH. 1 =	L/S 1 =	^1 VEH.
CH. 2 =	L/S 2 =	^2 VEH.
CH. 3 =	L/S 3 =	^3 VEH.
CH. 4 =	L/S 4 =	^4 VEH.
CH. 5 =	L/S 5 =	^5 VEH.
CH. 6 =	L/S 6 =	^6 VEH.
CH. 7 =	L/S 7 =	^7 VEH.
CH. 8 =	L/S 8 =	^8 VEH.
CH. 9 =	L/S 9 =	^2 PED. / VEH. 1 FYA
CH. 10 =	L/S 10 =	^4 PED. / VEH. 3 FYA
CH. 11 =	L/S 11 =	^6 PED. / VEH. 5 FYA
CH. 12 =	L/S 12 =	^8 PED. / VEH. 7 FYA
CH. 13 =	L/S 13 =	O'LAP A VEH.
CH. 14 =	L/S 14 =	O'LAP B VEH.
CH. 15 =	L/S 15 =	O'LAP C VEH.
CH. 16 =	L/S 16 =	O'LAP D VEH.

MMU PROGRAM CARD

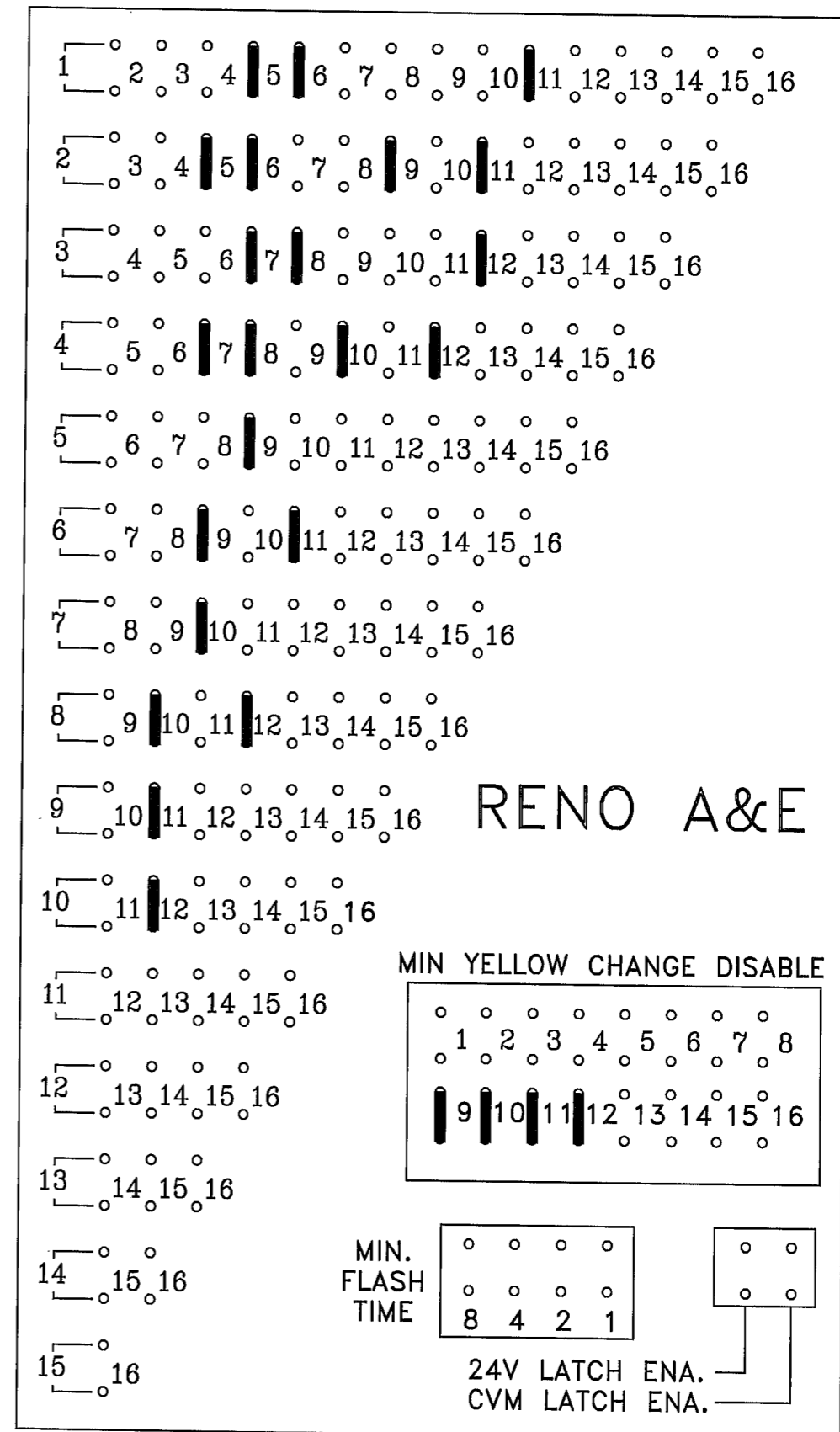

M.M.U. C/C'S AND PROGRAM CARD

DETECTOR RACK #1 34030G1

POWER SUPPLY OR B.I.U.	L3	L1	L7	L5	L11	L9	L15	L13	PMT 5 □ 2CH OPTICOM/ OPIC CH. C CH. D	PMT 3 □ 4CH □ 2CH OPTICOM/ OPIC CH. A CH. B	PGM. CARD
	5-1	1-1	6-1	2-1	7-1	3-1	□ 2CH	□ 2CH			
	□ 2CH	□ 2CH	□ 2CH	□ 2CH	□ 2CH	□ 2CH	□ 2CH	□ 2CH			
	5-2	1-2	6-2	2-2	7-2	3-2					
	L4	L2	L8	L6	L12	L10	L16	L14	PMT 6	PMT 4	

J13 C/C 171-1083-515 DC POWER	J16 C/C 33284G8 EXP. OUTPUTS	J14 C/C 33284G2 LPS 1-8	J18 C/C 33284G9 SYS. OUTPUTS	J15 C/C 33284G3 LPS 9-16	J17 C/C 171-1083-515 AC POWER	J19 C/C 33284G17 PGM. CARD
-------------------------------------	------------------------------------	-------------------------------	------------------------------------	--------------------------------	-------------------------------------	----------------------------------

1

ADDRESS TABLE					
RACK #	JMPR	DET. #S	RACK #	JMPR	DET. #S
1	□□□□	1-16	5	□□□□	65-80
2	□□□□	17-32	6	□□□□	81-96
3	□□□□	33-48	7	□□□□	97-112
4	□□□□	49-64	8	□□□□	113-128

DETECTOR ASSIGNMENTS		
CONT. INPUT	PHASE ASGN.	DETECTOR TYPE
1	1-1	
2	1-2	
3	5-1	
4	5-2	
5	2-1	
6	2-2	
7	6-1	
8	6-2	
9	3-1	
10	3-2	
11	7-1	
12	7-2	
13		
14		
15		
16		
17	4-1	
18	4-2	
19	4-3	
20		
21	8-1	
22	8-2	
23	8-3	
24		
25		
26		
26		
28		
29	SD-1	
30	SD-2	
31	SD-3	
32	SD-4	

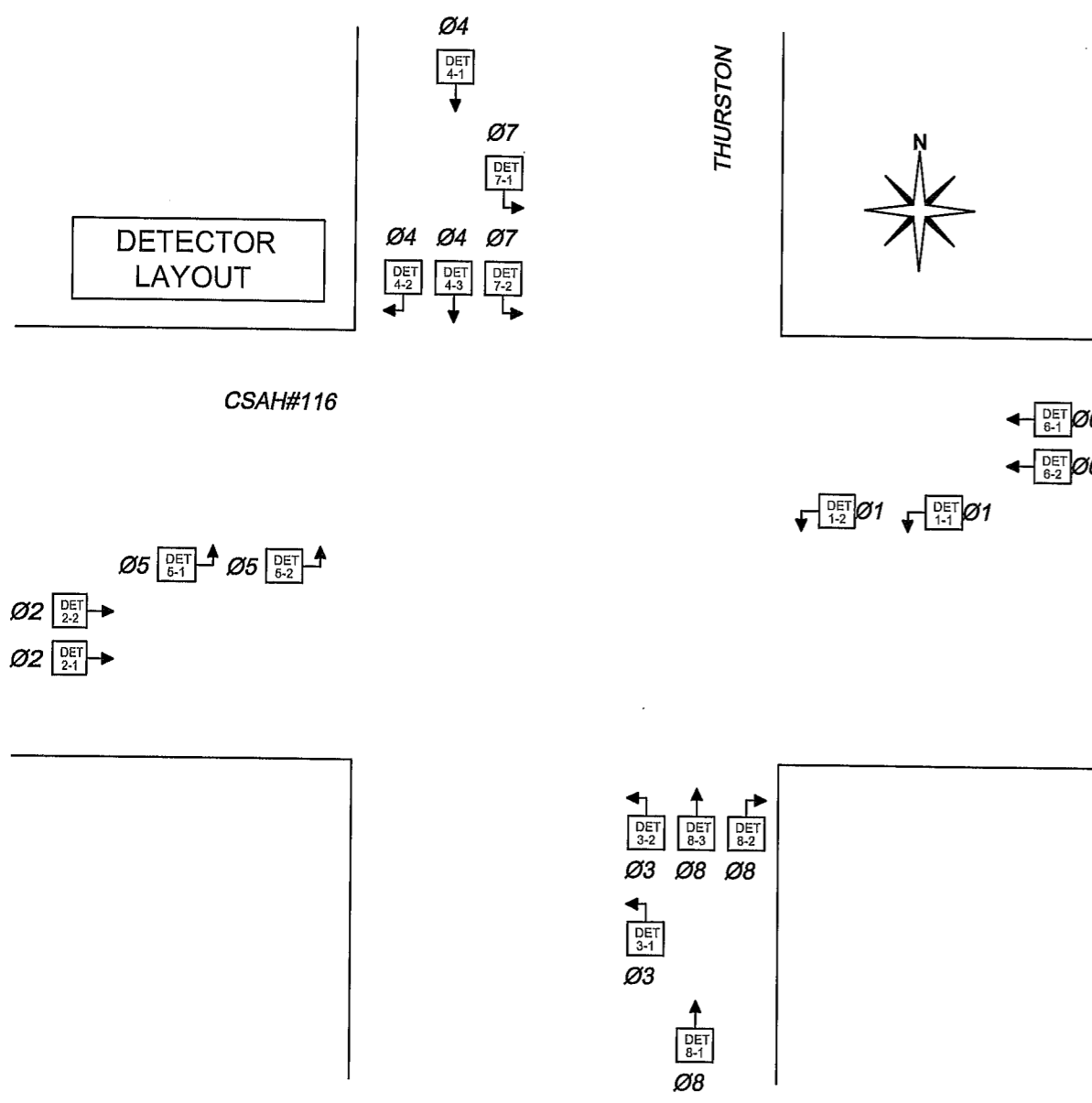

DETECTOR RACK PROGRAMMING JUMPERS																												
DET. TYPE	JP1	JP2	SLOT 1/2 ①						SLOT 3/4 ①						SLOT 5/6 ①						SLOT 7/8 ①							
			JP3	JP4	JP5	JP6	JP7	JP8	JP9	JP10	JP11	JP12	JP13	JP14	JP15	JP16	JP17	JP18	JP19	JP20	JP21	JP22	JP23	JP24	JP25	JP26	JP27	JP28
① TS-1	NO	NO	○	○	○	○	○	○	○	○	○	○	○	○	○	○	○	○	○	○	○	○	○	○	○	○	○	○
② TS-2	YES	YES	○	○	○	○	○	○	○	○	○	○	○	○	○	○	○	○	○	○	○	○	○	○	○	○	○	○
③ LM-632T 262-FC	NO	NO	○	○	○	○	○	○	○	○	○	○	○	○	○	○	○	○	○	○	○	○	○	○	○	○	○	○
④ MAG.	NO	NO	○	○	○	○	○	○	○	○	○	○	○	○	○	○	○	○	○	○	○	○	○	○	○	○	○	○

DETECTOR LOOP
INTERFACE #1
ASSY. 34040G1

J1
TO DR1:J14
C/C 33284G2

J2
TO DR1:J15
C/C 33284G3

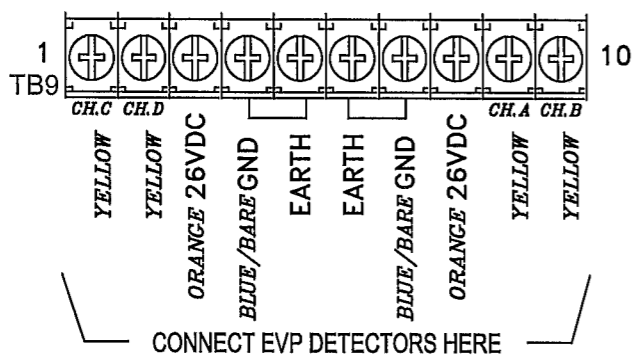
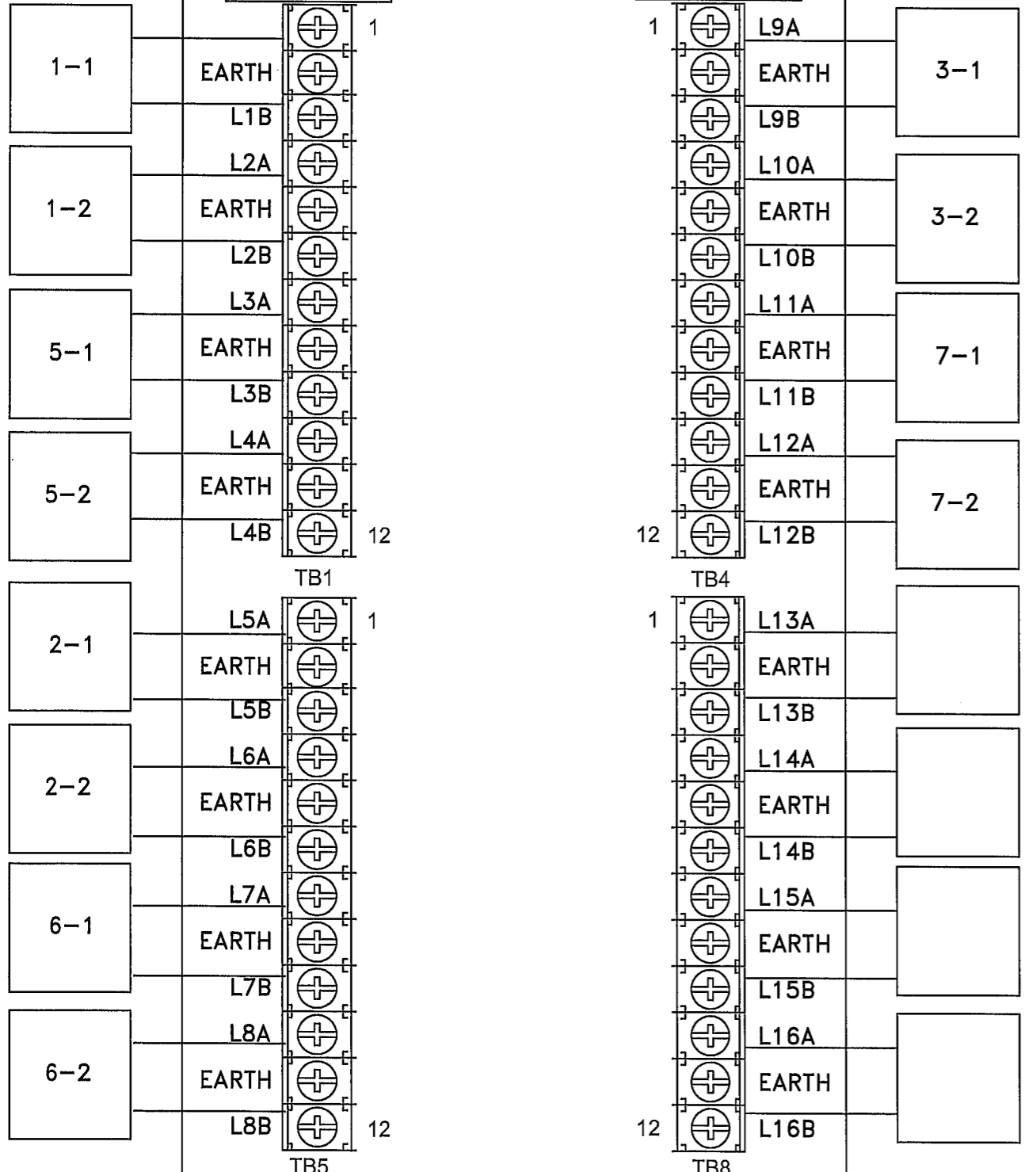

DET. LOOPS 9-16 (J15) C/C 33284G3

PIN	SIGNAL	TO
1	LOOP 9+	LPI2:TB4-1
2	LOOP 9-	LPI2: TB4-3
3	LOOP 10+	LPI2: TB4-4
4	LOOP 10-	LPI2: TB4-6
5	LOOP 11+	LPI2: TB4-7
6	LOOP 11-	LPI2: TB4-9
7	LOOP 12+	LPI2: TB4-10
8	LOOP 12-	LPI2: TB4-12
9	LOOP 13+	LPI2: TB8-1
10	LOOP 13-	LPI2: TB8-3
11	LOOP 14+	LPI2: TB8-4
12	LOOP 14-	LPI2: TB8-6
13	LOOP 15+	LPI2: TB8-7
14	LOOP 15-	LPI2: TB8-9
15	LOOP 16+	LPI2: TB8-10
16	LOOP 16-	LPI2: TB8-12
17	----	
18	----	
19	----	
20	----	

DET. LOOPS 1-8 (J14) C/C 33284G2

PIN	SIGNAL	TO
1	LOOP 1+	LPI1:TB1-1
2	LOOP 1-	LPI1: TB1-3
3	LOOP 2+	LPI1: TB1-4
4	LOOP 2-	LPI1: TB1-6
5	LOOP 3+	LPI1: TB1-7
6	LOOP 3-	LPI1: TB1-9
7	LOOP 4+	LPI1: TB1-10
8	LOOP 4-	LPI1: TB1-12
9	LOOP 5+	LPI1: TB5-1
10	LOOP 5-	LPI1: TB5-3
11	LOOP 6+	LPI1: TB5-4
12	LOOP 6-	LPI1: TB5-6
13	LOOP 7+	LPI1: TB5-7
14	LOOP 7-	LPI1: TB5-9
15	LOOP 8+	LPI1: TB5-10
16	LOOP 8-	LPI1: TB5-12
17	PMT. DET. CH. C	LPI1: TB9-1
18	PMT. DET. CH. D	LPI1: TB9-2
19	KEY PIN	
20	PMT. CH. C/D +26VDC	LPI1: TB9-3
21	PMT. DC GROUND	LPI1: TB9-4,7
22	PMT. CH. A/B +26VDC	LPI1: TB9-8
23	PMT. DET. CH. A	LPI1: TB9-9
24	PMT. DET. CH. B	LPI1: TB9-10
25	----	
26	----	

DET. RACK POWER C/C 171-1083-515			
P1/ DR:J13	P2/ DR:J17	FUNCTION	TO
1		+12 VDC (DET. POWER)	PB-3
2		+24 VDC (BIU POWER)	PB-2
3		LOGIC GROUND	PB-1
4		EARTH GROUND	PB-9
5		"KEY PIN"	
6		LINE FREQUENCY REF.	PB-5
	1	EARTH GROUND	----
	2	AC LINE	PB-12
	3	AC NEUTRAL	PB-10
	4	LOGIC GROUND	----

EXPANSION OUTPUTS C/C 33284G8		
J16	FUNCTION	TO
17	DET. 17 / PMT. A OUT	MP:B19
18	DET. 18 / PMT. B OUT	MP:B20
19	PMT. C OUT	MP:B17
20	PMT. D OUT	MP:B18

DETECTOR LOOP INTERFACE

DETECTOR RACK #2 34030G1

POWER SUPPLY OR B.I.U.	L3	L1	L7	L5	L11	L9	L15	L13	NOT USED	NOT USED	PGM. CARD
	4-3	4-1	8-3	8-1			SD-3	SD-1			
	<input type="checkbox"/> 2CH	<input type="checkbox"/> 2CH	<input type="checkbox"/> 2CH	<input type="checkbox"/> 2CH	<input type="checkbox"/> 2CH	<input type="checkbox"/> 2CH	<input type="checkbox"/> 2CH	<input type="checkbox"/> 2CH			
		4-2		8-2			SD-4	SD-2			
	L4	L2	L8	L6	L12	L10	L16	L14			

<input checked="" type="checkbox"/> J13 C/C 33284G10 DC POWER	<input type="checkbox"/> J16 C/C 33284G8 EXP. OUTPUTS	<input checked="" type="checkbox"/> J14 C/C 33284G2 LPS 1-8	<input type="checkbox"/> J18 C/C 33284G9 SYS. OUTPUTS	<input checked="" type="checkbox"/> J15 C/C 33284G3 LPS 9-16	<input checked="" type="checkbox"/> J17 C/C 33284G6 AC POWER	<input type="checkbox"/> J19 C/C 33284G17 PGM. CARD
---	---	---	---	--	--	---

ADDRESS TABLE		
RACK #	JMPR	DET. #S
1		1-16
2		17-32
3		33-48
4		49-64

- ① INSTALL JUMPERS ON JP31 THRU JP34 WHEN A SHELF MOUNT POWER SUPPLY IS USED. WARNING - DO NOT INSTALL JUMPERS WHEN A PLUG-IN POWER SUPPLY IS USED.
- ② INSTALL JUMPERS ON JP38 - JP55 WHEN PGM. CARD IS NOT USED.
- ③ PROGRAM CARD AND PLUG-IN POWER SUPPLY ARE FOR TS-1 APPLICATIONS ONLY. REMOVE FOR TS-2 APPLICATIONS.
- ④ PROGRAM JUMPERS USING CONFIGURATION NUMBER AS SHOWN BY ASTERISK.

DETECTOR RACK PROGRAMMING JUMPERS																																					
DC POWER				DET. TYPE	CONFIGURATION ④ SLOT 1/2								CONFIGURATION ④ SLOT 3/4								CONFIGURATION ④ SLOT 5/6								CONFIGURATION ④ SLOT 7/8								DET. CMNS. JP38-JP55
JP31	JP32	JP33	JP34		JP3	JP4	JP5	JP6	JP7	JP8	JP9	JP10	JP11	JP12	JP13	JP14	JP15	JP16	JP17	JP18	JP19	JP20	JP21	JP22	TP1	JP23	JP24	JP25	JP26	JP27	JP28	TP2	JP29	JP30			
				1	TS-1																														②		
				2	* TS-2																														②		
				3	LM-632T 262-FC																														②		
				4	MAG.																														②		
				5	LM-642() (TS-2)																														②		

DETECTOR LOOP
INTERFACE #2
ASSY. 34040G1

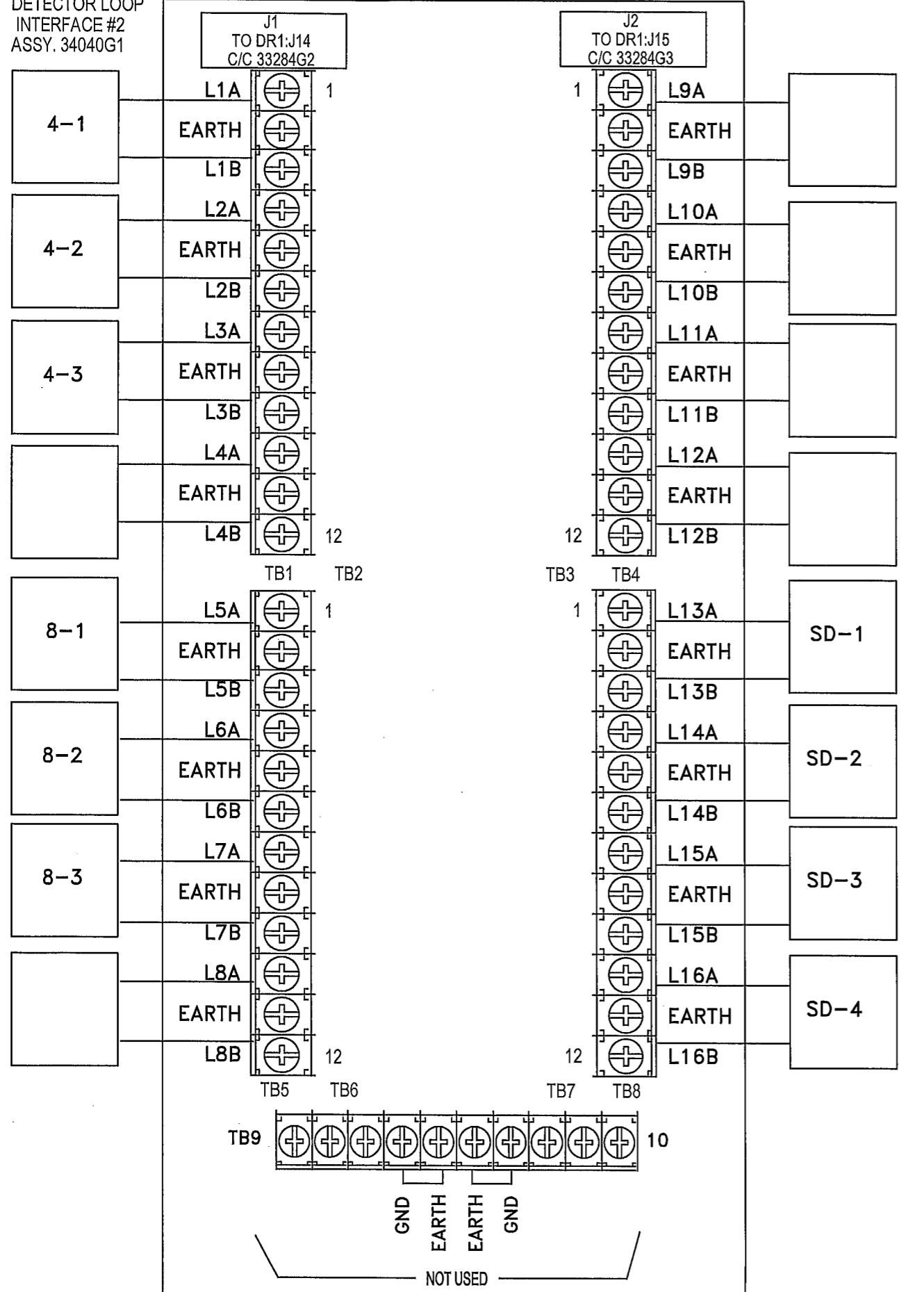

DET. LOOPS 9-16 (J15) C/C 33284G3		
PIN	SIGNAL	TO
1	LOOP 9+	LPI2:TB1-1
2	LOOP 9-	LPI2: TB1-3
3	LOOP 10+	LPI2: TB1-4
4	LOOP 10-	LPI2: TB1-6
5	LOOP 11+	LPI2: TB1-7
6	LOOP 11-	LPI2: TB1-9
7	LOOP 12+	LPI2: TB1-10
8	LOOP 12-	LPI2: TB1-12
9	LOOP 13+	LPI2: TB2-1
10	LOOP 13-	LPI2: TB2-3
11	LOOP 14+	LPI2: TB2-4
12	LOOP 14-	LPI2: TB2-6
13	LOOP 15+	LPI2: TB2-7
14	LOOP 15-	LPI2: TB2-9
15	LOOP 16+	LPI2: TB2-10
16	LOOP 16-	LPI2: TB2-12
17	----	
18	----	
19	----	
20	----	

DET. LOOPS 1-8 (J14) C/C 33284G2		
PIN	SIGNAL	TO
1	LOOP 1+	LPI1:TB1-1
2	LOOP 1-	LPI1: TB1-3
3	LOOP 2+	LPI1: TB1-4
4	LOOP 2-	LPI1: TB1-6
5	LOOP 3+	LPI1: TB1-7
6	LOOP 3-	LPI1: TB1-9
7	LOOP 4+	LPI1: TB1-10
8	LOOP 4-	LPI1: TB1-12
9	LOOP 5+	LPI1: TB2-1
10	LOOP 5-	LPI1: TB2-3
11	LOOP 6+	LPI1: TB2-4
12	LOOP 6-	LPI1: TB2-6
13	LOOP 7+	LPI1: TB2-7
14	LOOP 7-	LPI1: TB2-9
15	LOOP 8+	LPI1: TB2-10
16	LOOP 8-	LPI1: TB2-12
17	PMT. DET. CH. A	LPI1: TB3-1
18	PMT. DET. CH. B	LPI1: TB3-2
19	KEY PIN	
20	PMT. CH. A/B +26VDC	LPI1: TB3-3
21	PMT. DC GROUND	LPI1: TB3-4,7
22	PMT. CH. C/D +26VDC	LPI1: TB3-8
23	PMT. DET. CH. C	LPI1: TB3-9
24	PMT. DET. CH. D	LPI1: TB3-10
25	----	
26	----	

DET. RACK POWER C/C 171-1083-515			
P1/ DR:J13	P2/ DR:J17	FUNCTION	TO
1		+12 VDC (DET. POWER)	PB-3
2		+24 VDC (BIU POWER)	PB-2
3		LOGIC GROUND	PB-1
4		EARTH GROUND	PB-9
5		"KEY PIN"	
6		LINE FREQUENCY REF.	PB-5
	1	EARTH GROUND	----
	2	AC LINE	PB-12
	3	AC NEUTRAL	PB-10
	4	LOGIC GROUND	----

DETECTOR LOOP INTERFACE

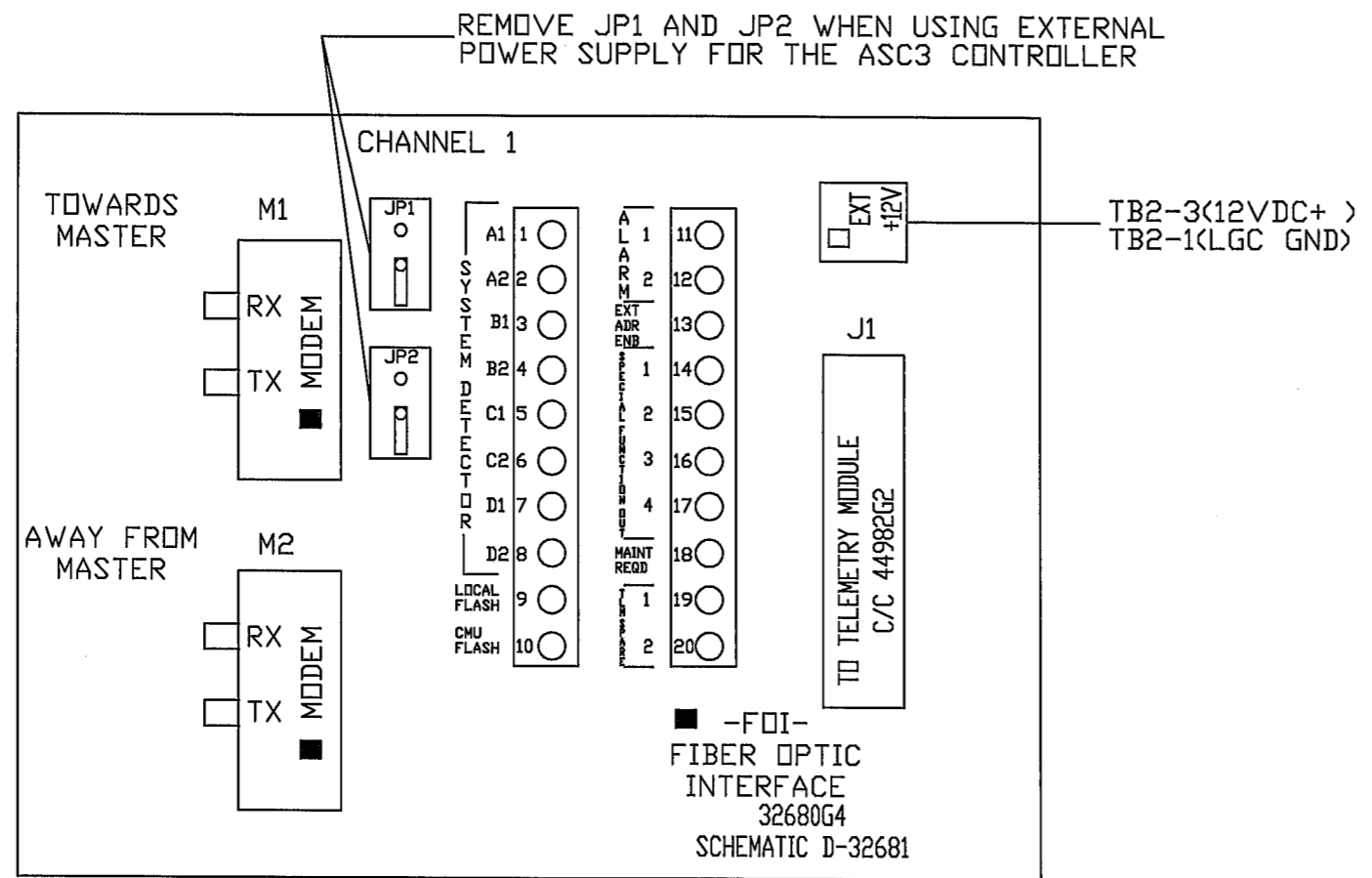

		-LT- LOCAL TELEMETRY 32680G4	
CONT. TELM. PORT	FIBER OPTIC INTERF.	COLOR	FUNCTION
J3	J1		
3	A4	BLACK	TRANSMIT
2	A3	BLACK	RECEIVE
7	A5	RED	+12 VDC
5	A2	GRAY	SIG. GND.

LOCAL RS-232 TELEMETRY (FOI)

B.I.U	DET	PH	F	DET	DLY	EXT	DET	PH	F	DET	DLY	EXT	DET	PH	F	DET	DLY	EXT	DET	PH	F	DET	DLY	EXT	EVP	PH	POLE #	CONT CH #
	CH 1	1	1	1-1			CH 5	2	1	2-1			CH 9	3	1	3-1			CH 13						CH 1	1-6	4	3
	CH 2	1	1	1-2			CH 6	2	1	2-2			CH 10	3	1	3-2			CH 14						CH 2	2-5	2	4
	CH 3	5	1	5-1			CH 7	6	1	6-1			CH 11	7	1	7-1			CH 15						CH 3	3-8	1	5
	CH 4	5	1	5-2			CH 8	6	1	6-2			CH 12	7	1	7-2			CH 16						CH 4	4-7	3	6
B.I.U	DET	PH	F	DET	DLY	EXT	DET	PH	F	DET	DLY	EXT	DET	PH	F	DET	DLY	EXT	DET	PH	F	DET	DLY	EXT				
	CH 17	4	3/8	4-1			CH 21	8	3/8	8-1			CH 25						CH 29		11	SD-1						
	CH 18	4	7	4-2	10		CH 22	8	7	8-2	10		CH 26						CH 30		11	SD-2						
	CH 19	4	1	4-3			CH 23	8	1	8-3			CH 27						CH 31		11	SD-3						
	CH 20						CH 24						CH 28						CH 32		11	SD-4						

EVP SENSORS

CABLE	DISCR. CHAN.	PHASES	POLE#	TERMINAL TB9		
				SIGNAL	DC(+)	GND
41	1	1-6	4	9	8	7
23	2	2-5	2	10	8	7
12	3	3-8	1	1	3	4
51	4	4-7	3	2	3	4

VEHICLE SIGNALS

CABLE	SIGNAL	TERMINAL						
		G ←	FLA	Y ←	R ←	G	Y	R
36	1-1	1	3	5	7			
48	1-2	2	4	6	8			
17	2-1,2-3					9	11	13
17	2-2					10	12	14
7	3-1	15	17	19	21			
36	3-2	16	18	20	22			
47	4-1					23	25	27
47	4-2					24	26	28
18	5-1	29	31	33	35			
7	5-2	30	32	34	36			
35	6-1,6-3					37	39	41
35	6-2					38	40	42
48	7-1	43	45	47	49			
18	7-2	44	46	48	50			
8	8-1					51	53	55
8	8-2					52	54	56

VEH DETECTORS

CABLE	DET	SLOT	FUNC	RACK	TERMINAL
15	1-1	1	1	1	L1
16	1-2	2	1	1	L2
53	2-1	5	1	1	L5
54	2-2	6	1	1	L6
28	3-1	9	1	1	L9
29	3-2	10	1	1	L10
42	4-1	17	3/8	2	L1
31	4-2	18	7	2	L2
32	4-3	19	1	2	L3
45	5-1	3	1	1	L3
46	5-2	4	1	1	L4
13	6-1	7	1	1	L7
14	6-2	8	1	1	L8
33	7-1	11	1	1	L11
34	7-2	12	1	1	L12
30	8-1	21	3/8	2	L5
26	8-2	22	7	2	L6
27	8-3	23	1	2	L7
43	SD-1	29	11	2	L13
44	SD-2	30	11	2	L14
24	SD-3	31	11	2	L15
25	SD-4	32	11	2	L16

PED PUSHBUTTONS

CABLE	PPB	TERMINAL	RETURN
52	2-1	PC2	GB1
22	2-2	PC2	GB1
39	4-1	PC4	GB1
52	4-2	PC4	GB1
11	6-1	PC6	GB1
39	6-2	PC6	GB1
22	8-1	PC8	GB1
11	8-2	PC8	GB1

PED SIGNALS

CABLE	SIGNAL	TERMINAL	
		WK	DW
50	2-1	57	61
20	2-2	58	62
38	4-1	63	67
47	4-2	64	68
9	6-1	69	73
37	6-2	70	74
19	8-1	75	79
8	8-2	76	80

EVP VERIFY LIGHTS

CABLE	CONTR CHAN.	PHASES	POLE#	TERM.
40	3	1-6	4	59
21	4	2-5	2	65
10	5	3-8	1	71
49	6	4-7	3	77