

ASC/2S-2100 CONTROLLER WITH:

- CONFIGURATION EEPROM 32790C1440
- SOFTWARE: V1.72
- SPECIAL SOFTWARE: SEE BELOW FUNCTION
- OVERLAPS
 - IN EEPROM
 - KEYBOARD ENTERED
- ANALOG TELEMETRY MODULE: 32825G1
- F/O TELEMETRY MODULE: 33525G1
- TEST INPUT A =
- TEST INPUT B =

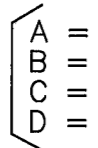

LEGEND

BIU()	BUS INTERFACE UNIT
BU()	C/C, BIU ()
CB()	CIRCUIT BREAKER ()
C/C	CONNECTING CABLE
CCA	CONTROLLER CABLE "A"
CDP	C/C, DR POWER
CMA	MMU/CMU CABLE "A"
CMB	MMU/CMU CABLE "B"
CPO	C/C PRE-EMPT OUTPUTS
CPP	C/C PRE-EMPT POWER
DR	DETECTOR RACK
DS()	DOOR SWITCH ()
FL()	FLASHER ()
FR()	FLASH XFER. RELAY
LS()	LOAD SWITCH
MC	MERCURY CONTACTOR
MP	MAIN PANEL
PAP	POWER-AUX PANEL
PSP	CAB. PWR. SUPPLY
SA	SURGE ARRESTOR
TB-()	TERM. BLOCK ()

MAIN PANEL PLUG-IN REQUIREMENTS

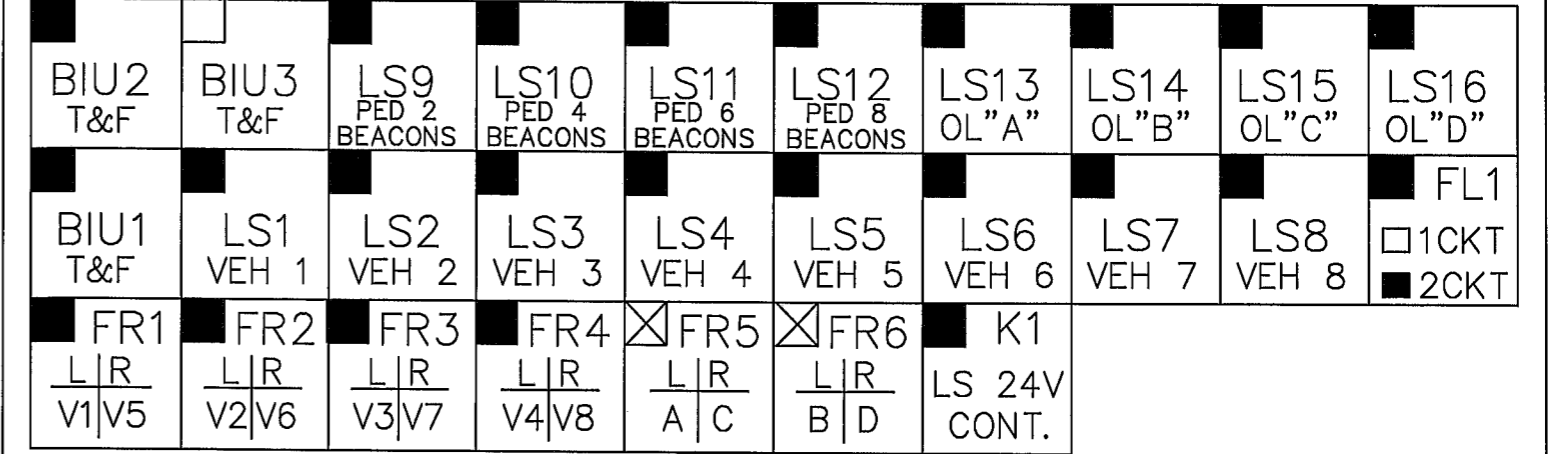

■ DENOTES TYPE OF OPERATION AND/OR WHERE PLUG-IN IS REQUIRED. L = LEFT, R = RIGHT.
 ⊗ DENOTES WHERE "UNUSED RED" JUMPER PART NUMBER 32448G1 IS REQUIRED. INSTALL BETWEEN PINS 1 & 3 FOR LOAD SWITCH OR PINS 6 & 8 AND 5 & 7 FOR FLASH TRANSFER RELAY.

FLASH:
 □ ∅2&6 YELLOW, ALL OTHERS RED.
 ■ ALL RED.
 ■ RELAYS DE-ENERGIZED FOR FLASH.
 □ RELAYS ENERGIZED FOR FLASH.

FLASHER	
PIN	FUNCTION
7	CIRCUIT #1
8	CIRCUIT #2
9	CHASSIS GND
10	AC COMMON
11	115 VAC
12	-----

LOAD SWITCH	
PIN	FUNCTION
1	115 VAC
2	CHASSIS GND
3	RED/DW OUTPUT
4	-----
5	YEL OUTPUT
6	RED/DW INPUT
7	GRN/W OUTPUT
8	YEL INPUT
9	+24 VDC
10	GRN/W INPUT
11	AC COMMON
12	-----

① 2.2K 10W

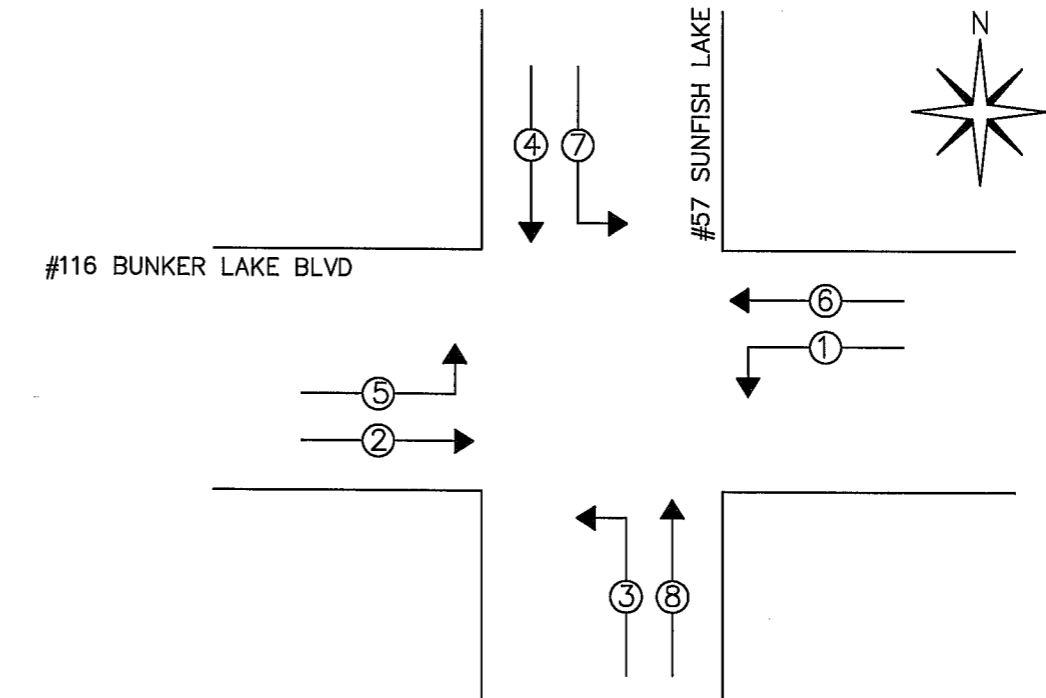

SHEET 1 OF 11

3 USE ONLY COPPER CONDUCTORS FOR FIELD AND SERVICE CONNECTIONS.
 2 CONNECT A.C. SERVICE TO TERMINAL BLOCK 501 (LINE), 502 (NEUTRAL) AND GB2 (EARTH) ON RIGHT SIDEWALL OF CABINET.
 ① INSTALL 2.2K, 10 WATT LOAD RESISTORS BETWEEN PINS 7 AND 11 ON LOAD SWITCHES 9, 10, 11 & 12.
 NOTES: UNLESS SPECIFIED OTHERWISE

DESIGNER G.V. T.C.C.	DATE 02/03/97	ECONOLITE CONTROL PRODUCTS INC.	TRAFFIC CONTROL CORPORATION	5653 MEMORIAL AVE. OAK PARK HTS, MN 55082
DRAWN MA TCC	6/9/04			CABINET SPECIFICATION: TS2TYPE1 2004 ANOKA COUNTY
CABINET SIZE		CUSTOMER: ANOKA COUNTY HIGHWAY DEPARTMENT		FLASHER
INSPECTED		INTERSECTION: CSAH #116 AT CSAH #57		SW.PACKS
APPROVED		LOCATION:		
CUSTOMER P.O.	INSTALLED BY	SALES ORDER NO.	SIZE B	DRAWING #TS20216PG INTERC

AUXILLARY SWITCH PANEL

POLICE SWITCH PANEL

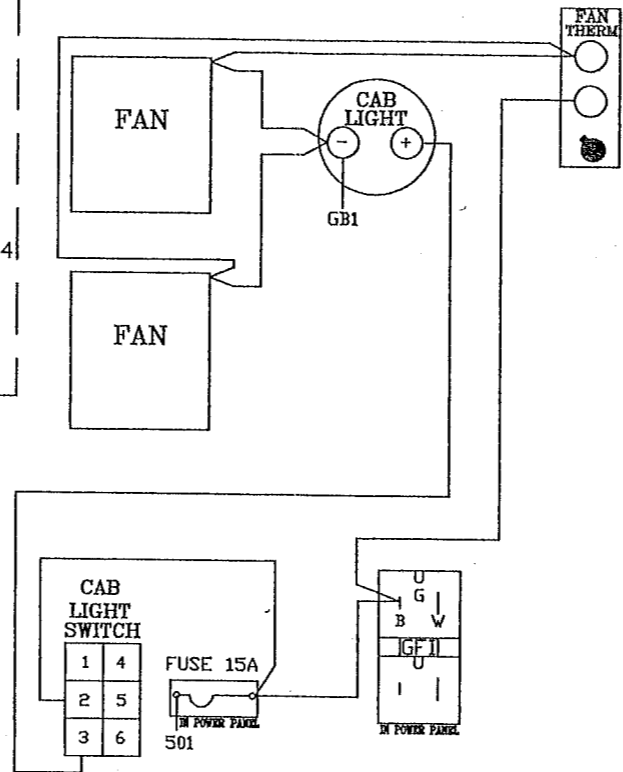
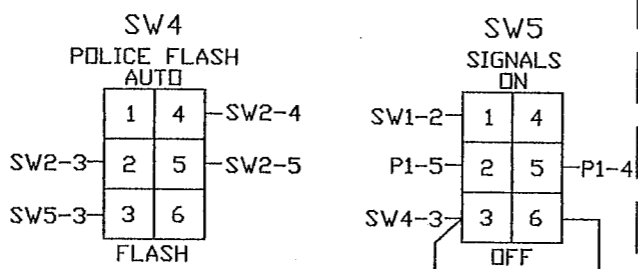
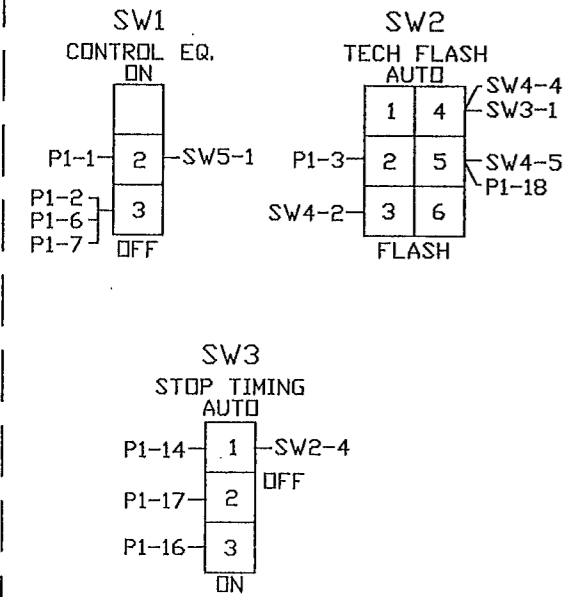

POWER/AUX PANEL (PAP) 34830G5

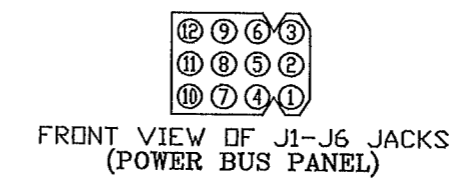
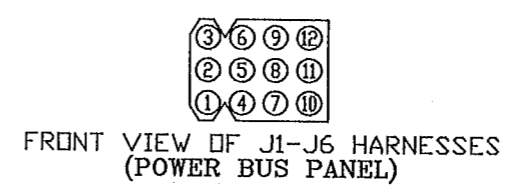
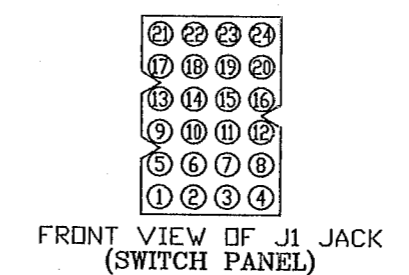
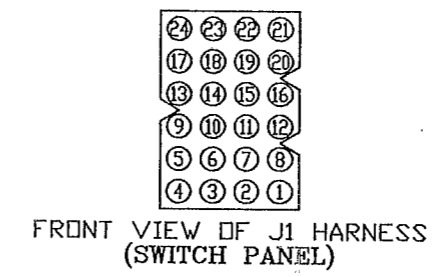
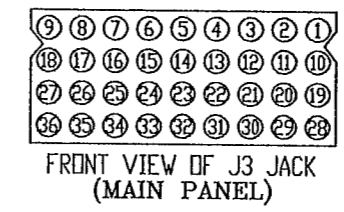
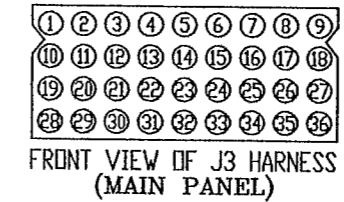
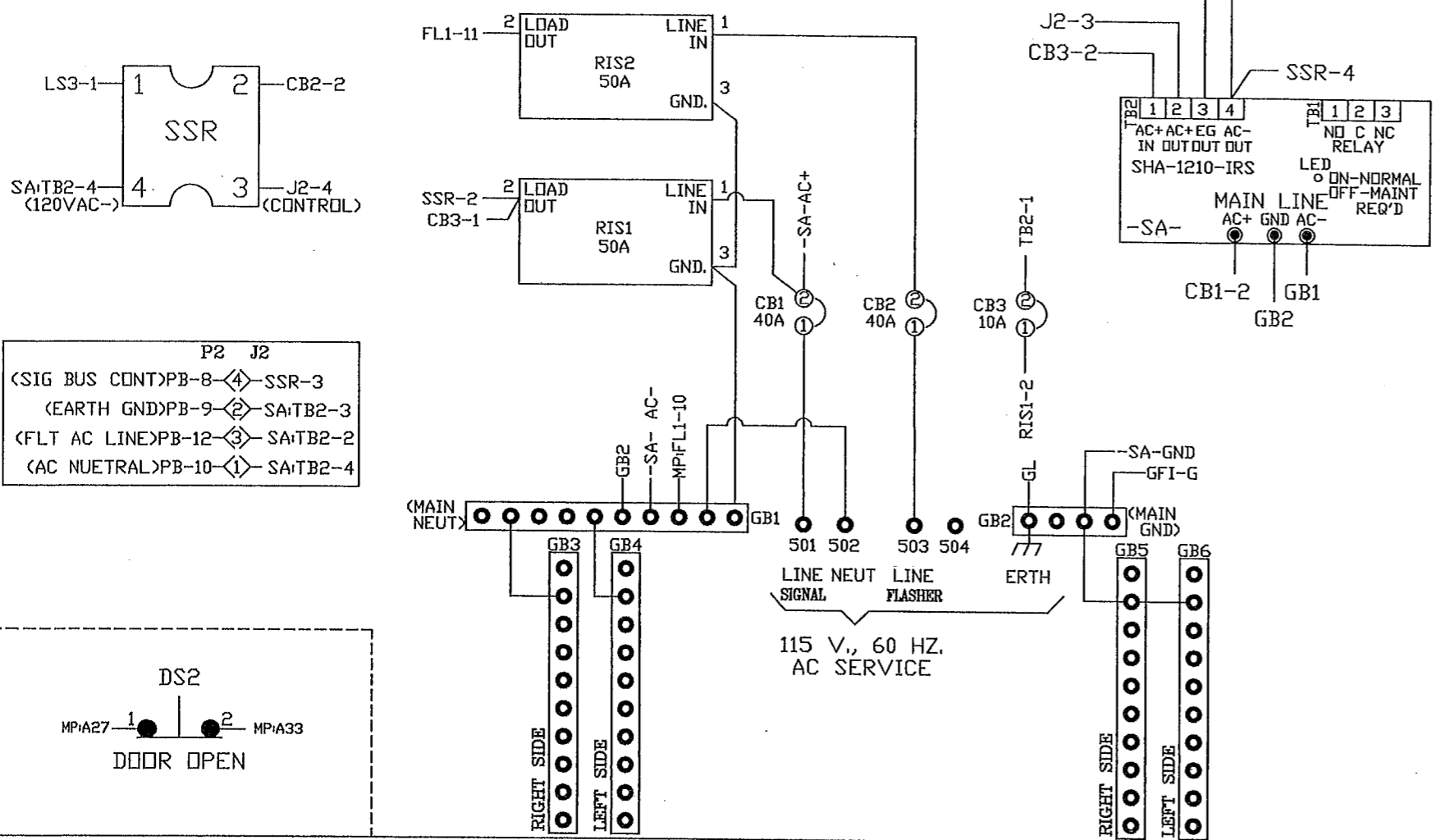

J3		P1	
J3-36	1	1	SW1-2
MMB-1	2	2	SW1-3
MMA-37	3	3	SW2-3
K1-10	4	4	SW5-5
FR6-2	5	5	SW5-2
MMB-2	6	6	SW1-3
MMA-20	7	7	SW1-3
	8	8	---
	9	9	---
	10	10	---
	11	11	---
	12	12	---
A-39	13	13	---
A-35	14	14	SW3-1
A-40	15	15	---
A-31	16	16	SW3-3
A-30	17	17	SW3-2
A-32	18	18	SW2-5
A-38	19	19	---
A-33	20	20	---
A-34	21	21	---
K1-9	22	22	---
B-3	23	23	---
B-4	24	24	---

J3		J1	
A-35	25	1	TB1-1
K1-11	26	2	TB1-2
	27	---	TB1-3
B-5	28	4	TB1-4
J1-31B	29	5	TB1-5
	30	---	TB1-6
J1-27B	31	7	TB1-7
K1-10	32	8	TB1-8
	33	---	TB1-9
K1-2	34	10	TB1-10
MMB-18	35	11	TB1-11
J3-1	36	12	TB1-12

CONFIRMATION BEACONS

EVP 3 = 1-6
 EVP 4 = 2-5
 EVP 5 = 3-8
 EVP 6 = 4-7

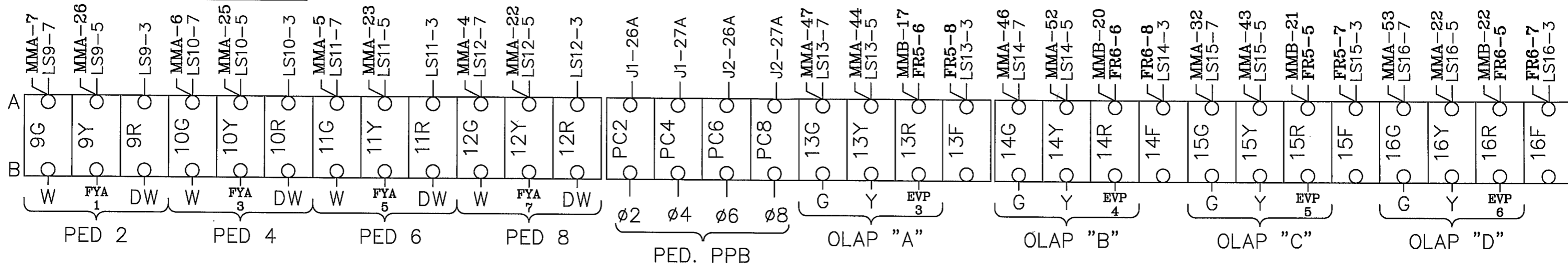

(P.B. COMMON TO GB1)

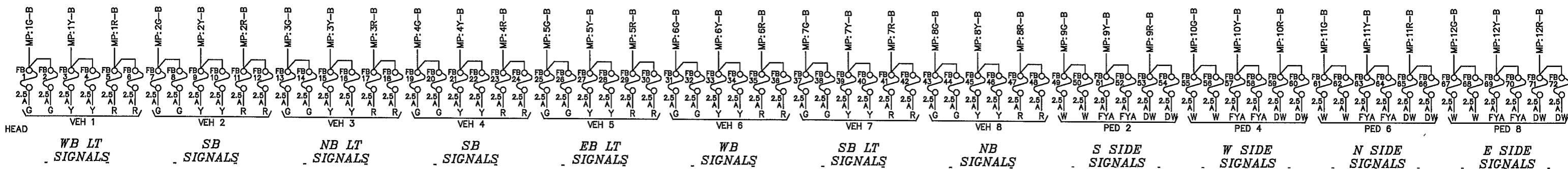
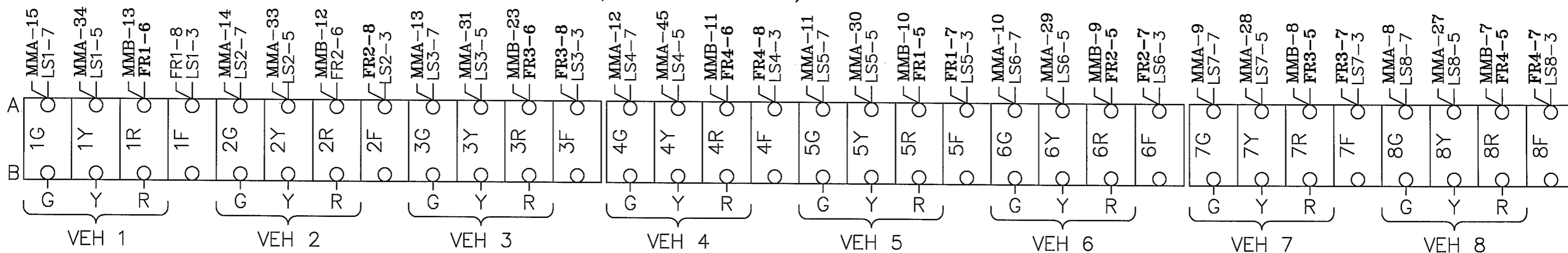

2.2K
10W

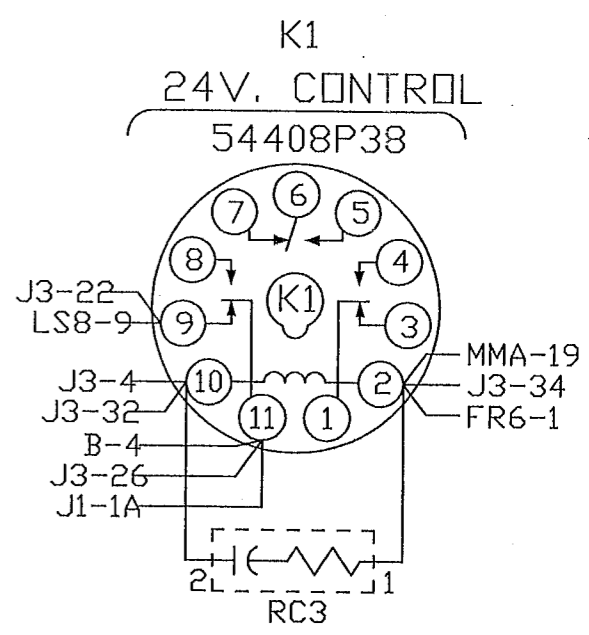
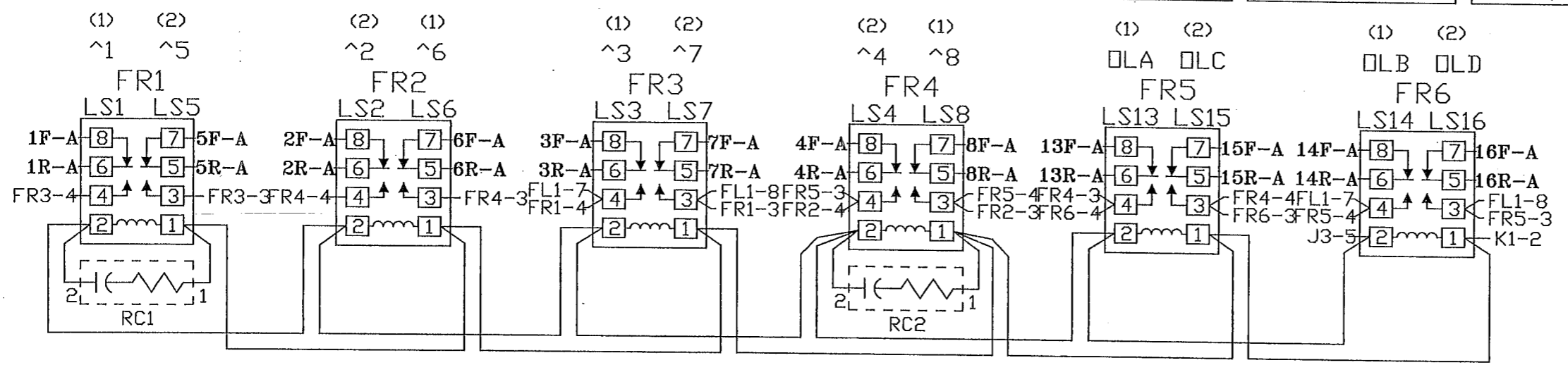
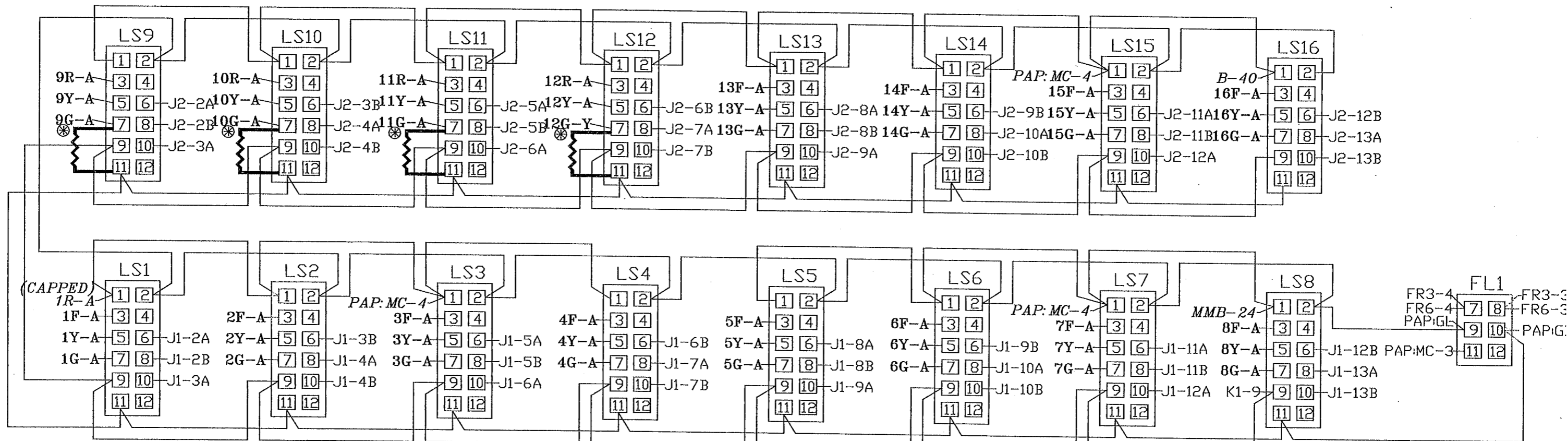

LOADBAY AND FLASH RELAY'S

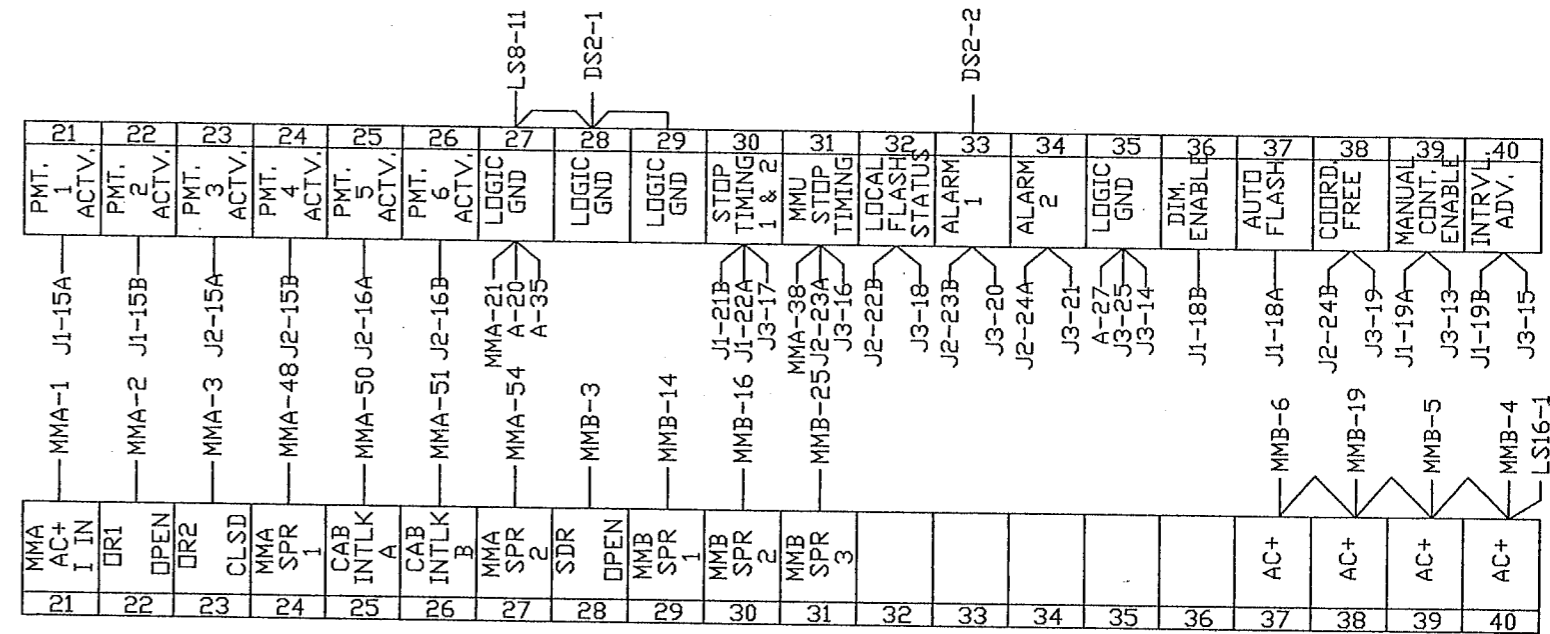
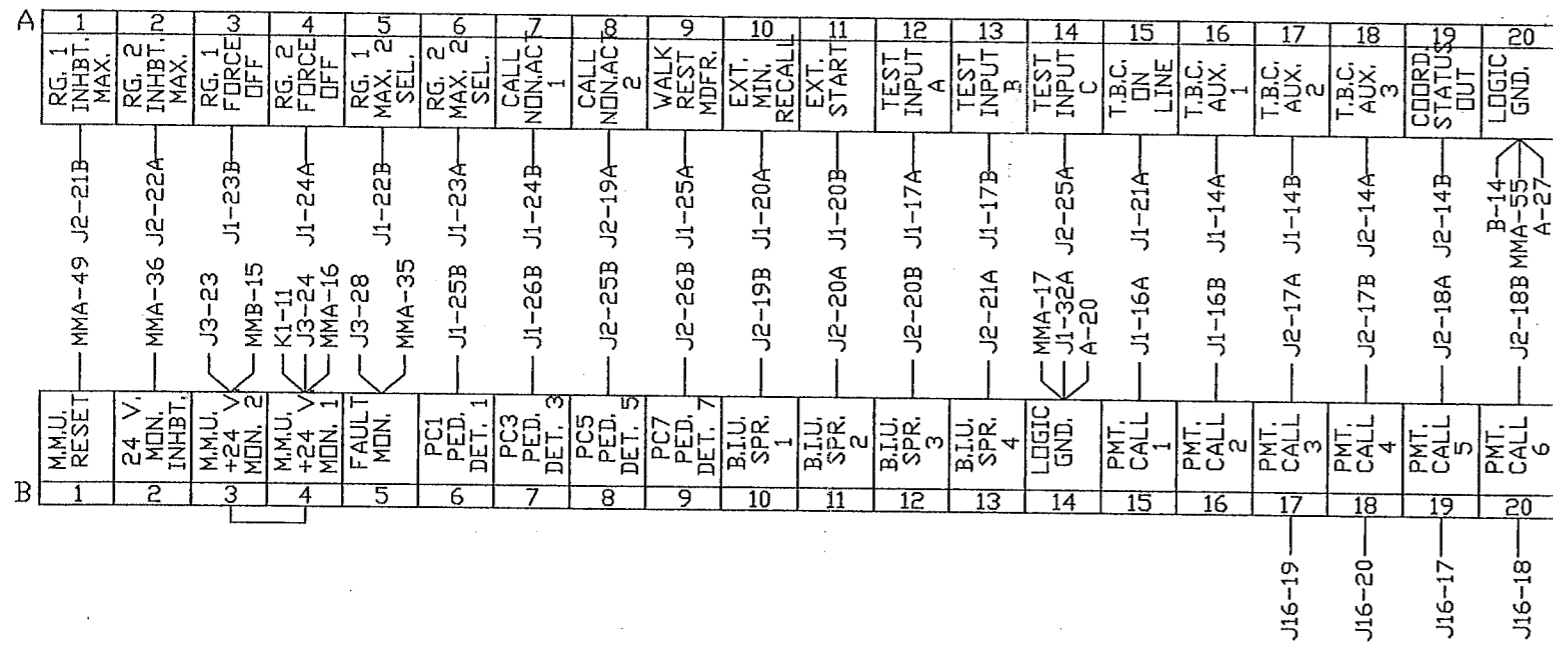

INTERFACE TERMINAL BLOCKS

J1 BIU #1			J2 BIU #2		
PIN	FUNCTION	TD	PIN	FUNCTION	TD
1A	+24 VDC	K1-11	1A	+24 VDC	J2-1B
1B	+24 VDC	J2-1B	1B	+24 VDC	J1-1B
2A	LS1 RED	LS1-6	2A	LS9 RED	LS9-6
2B	LS1 YELLOW	LS1-8	2B	LS9 YELLOW	LS9-8
3A	LS1 GREEN	LS1-10	3A	LS9 GREEN	LS9-10
3B	LS2 RED	LS2-6	3B	LS10 RED	LS10-6
4A	LS2 YELLOW	LS2-8	4A	LS10 YELLOW	LS10-8
4B	LS2 GREEN	LS2-10	4B	LS10 GREEN	LS10-10
5A	LS3 RED	LS3-6	5A	LS11 RED	LS11-6
5B	LS3 YELLOW	LS3-8	5B	LS11 YELLOW	LS11-8
6A	LS3 GREEN	LS3-10	6A	LS11 GREEN	LS11-10
6B	LS4 RED	LS4-6	6B	LS12 RED	LS12-6
7A	LS4 YELLOW	LS4-8	7A	LS12 YELLOW	LS12-8
7B	LS4 GREEN	LS4-10	7B	LS12 GREEN	LS12-10
8A	LS5 RED	LS5-6	8A	LS13 RED	LS13-6
8B	LS5 YELLOW	LS5-8	8B	LS13 YELLOW	LS13-8
9A	LS5 GREEN	LS5-10	9A	LS13 GREEN	LS13-10
9B	LS6 RED	LS6-6	9B	LS14 RED	LS14-6
10A	LS6 YELLOW	LS6-8	10A	LS14 YELLOW	LS14-8
10B	LS6 GREEN	LS6-10	10B	LS14 GREEN	LS14-10
11A	LS7 RED	LS7-6	11A	LS15 RED	LS15-6
11B	LS7 YELLOW	LS7-8	11B	LS15 YELLOW	LS15-8
12A	LS7 GREEN	LS7-10	12A	LS15 GREEN	LS15-10
12B	LS8 RED	LS8-6	12B	LS16-RED	LS16-6
13A	LS8 YELLOW	LS8-8	13A	LS16-YELLOW	LS16-8
13B	LS8 GREEN	LS8-10	13B	LS16-GREEN	LS16-10
14A	TBC AUX 1	A-16	14A	TBC AUX 3	A-18
14B	TBC AUX 2	A-17	14B	COORD. STATUS	A-19
15A	PMT ACT 1	A-21	15A	PMT ACT 3	A-23
15B	PMT ACT 2	A-22	15B	PMT ACT 4	A-24
16A	PMT CALL 1	B-15	16A	PMT ACT 5	A-25
16B	PMT CALL 2	B-16	16B	PMT ACT 6	A-26
17A	TEST A	A-12	17A	PMT CALL 3	B-17
17B	TEST B	A-13	17B	PMT CALL 4	B-18
18A	AUTO FLASH	A-37	18A	PMT CALL 5	B-19
18B	DIM. ENABLE	A-36	18B	PMT CALL 6	B-20
19A	MANUAL CONT.	A-39	19A	CNA 2	A-8
19B	INT. ADVANCE	A-40	19B	SPARE 1	B-10
20A	EXT. MIN. RECALL	A-10	20A	SPARE 2	B-11
20B	EXT. START	A-11	20B	SPARE 3	B-12
21A	TBC ONLINE	A-15	21A	SPARE 4	B-13
21B	STOP TIME (1)	A-30	21B	INHIBIT MAX (1)	A-1
22A	STOP TIME (2)	A-30	22A	INHIBIT MAX (2)	A-2
22B	MAX. 2 (1)	A-5	22B	LOCAL FLASH	A-32
23A	MAX. 2 (2)	A-6	23A	MMU FLASH	A-31
23B	FORCE OFF (1)	A-3	23B	ALARM 1	A-33
24A	FORCE OFF (2)	A-4	24A	ALARM 2	A-34
24B	CNA 1	A-7	24B	COORD FREE IN	A-38
25A	WALK REST MOD.	A-9	25A	TEST C	A-14
25B	PED. ISO. 1	B-6	25B	PED. ISO. 5	B-8
26A	PED. ISO. 2	PC2-A	26A	PED. ISO. 6	PC6-A
26B	PED. ISO. 3	B-7	26B	PED. ISO. 7	B-9
27A	PED. ISO. 4	PC4-A	27A	PED. ISO. 8	PC8-A
27B	PED. ISO. COMN.	J3-31	27B	PED. ISO. COMN.	J1-27B
28A	ADDR. SEL. 0	-----	28A	ADDR. SEL. 0	J2-32A
28B	ADDR. SEL. 1	-----	28B	ADDR. SEL. 1	-----
29A	ADDR. SEL. 2	-----	29A	ADDR. SEL. 2	-----
29B	ADDR. SEL. 3	-----	29B	ADDR. SEL. 3	-----
30A	RESERVED	-----	30A	RESERVED	-----
30B	RESERVED	-----	30B	RESERVED	-----
31A	EARTH GND.	LS12-2	31A	EARTH GND.	J1-31A
31B	LINE FREQ. REF.	J3-29	31B	LINE FREQ. REF.	J1-31B
32A	LOGIC GND.	B-14	32A	LOGIC GND.	J1-32B
32B	LOGIC GND.	J2-32A	32B	LOGIC GND.	J2-32A

MAIN PANEL CONTROL POWER C/C 34842G4	
PIN	FUNCTION
1	LOGIC GND
2	+24 VDC (IN)
3	-----
4	MMU FAULT MONITOR (IN)
5	LINE FREQ. REFERENCE (IN)
6	-----
7	+12 VAC (IN)
8	SIGNAL BUS CONTROL (IN)
9	-----
10	FILTERED AC NEUTRAL (IN)
11	CONT. EQUIP. AC LINE (OUT)
12	FILTERED AC LINE (IN)

CONTROLLER POWER (CCA2) C/C 34842G3			
WIRE	PIN	SIGNAL	TD
1	A	FAULT MONITOR	PB-4
2	U	AC NEUTRAL	PB-10
3	V	EARTH GROUND	PB-9
4	W	LOGIC GROUND	PB-1
5	P	AC LINE	PB-11
6	SHL	EARTH GROUND	CCA2-V

TYPE 1 CONTROLLER POWER C/C 34842G2		
PIN	FUNCTION	TD
A	AC NEUTRAL	PB-10
B	-----	-----
C	AC LINE	PB-11
D	-----	-----
E	-----	-----
F	-----	-----
G	FAULT MON.	PB-4
H	LOGIC GND.	PB-1
I	EARTH GND.	PB-9
J	-----	-----
SHL	EARTH GND.	PIN H

CABINET POWER SUPPLY C/C 34842G1		
PIN	FUNCTION	TD
A	AC NEUTRAL	PB-10
B	LINE FREQUENCY REF.	PB-5
C	AC LINE	PB-11
D	+12 VDC	PB-3
E	+24 VDC	PB-2
F	RESERVED	-----
G	LOGIC GND.	PB-1
H	EARTH GND.	PB-9
I	+12 VAC	PB-7
J	RESERVED	-----
SHL	EARTH GND.	PIN H

CONTROLLER PORT 1 CONNECTOR			
PIN	SIGNAL	TD	FUNCTION
1	TWISTED PAIR 1+	SDLC-1	CONT TXD+
2	LOGIC GND.	-----	-----
3	TWISTED PAIR 2+	SDLC-4	CONT TXC+
4	LOGIC GND.	-----	-----
5	TWISTED PAIR 3+	SDLC-7	CONT RXD+
6	LOGIC GND.	-----	-----
7	TWISTED PAIR 4+	SDLC-10	CONT RXC+
8	LOGIC GND.	-----	-----
9	TWISTED PAIR 1-	SDLC-2	CONT TXD-
10	PORT 1 DISABLE	-----	-----
11	TWISTED PAIR 2-	SDLC-5	CONT TXC-
12	EARTH GND.	SHIELD WIRE	-----
13	TWISTED PAIR 3-	SDLC-8	CONT RXD-
14	RESERVED	-----	-----
15	TWISTED PAIR 4-	SDLC-11	CONT RXC-

MMU & BIU PORT 1 CONNECTOR			
PIN	SIGNAL	TD	FUNCTION
1	TWISTED PAIR 1+	SDLC-1	BIU RXD+
2	LOGIC GND.	-----	-----
3	TWISTED PAIR 2+	SDLC-4	BIU RXC+
4	LOGIC GND.	-----	-----
5	TWISTED PAIR 3+	SDLC-7	BIU TXD+
6	LOGIC GND.	-----	-----
7	TWISTED PAIR 4+	SDLC-10	BIU TXC+
8	LOGIC GND.	-----	-----
9	TWISTED PAIR 1-	SDLC-2	BIU RXD-
10	PORT 1 DISABLE	-----	-----
11	TWISTED PAIR 2-	SDLC-5	BIU RXC-
12	EARTH GND.	SHIELD WIRE	-----
13	TWISTED PAIR 3-	SDLC-8	BIU TXD-
14	RESERVED	-----	-----
15	TWISTED PAIR 4-	SDLC-11	BIU TXC-

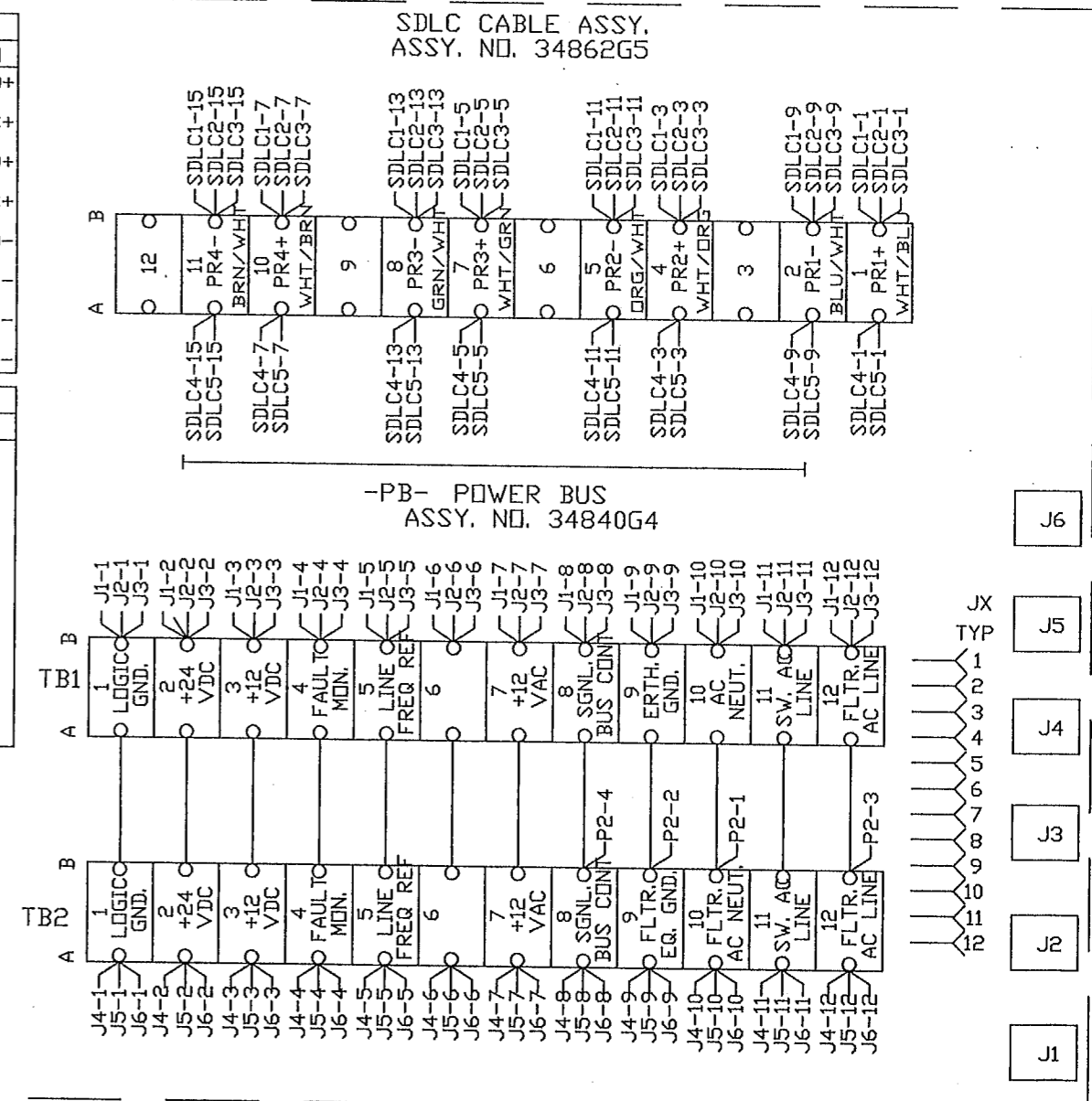
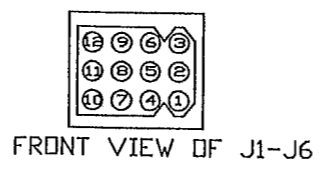
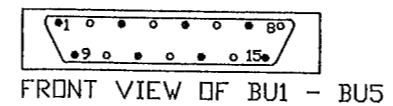

BIU AND CONNECTING CABLES

WIRE LIST FOR NEMA MALFUNCTION MANAGEMENT UNIT

CONNECTOR "A" (MMA)				CONNECTOR "B" (MMB)			
PIN	WIRE	MON. FUNCTION	SIG. FUNCTION	PIN	WIRE	MON. FUNCTION	SIG. FUNCTION
A	A-1	AC+ I INPUT	B21	A	B-1	AC+ II INPUT	J3-2
B	A-2	OUT RLY 1 OPEN	B22	B	B-2	S. DLY RLY COMM.	J3-6
C	A-3	OUT RLY 2 CLSD	B23	C	B-3	S. DLY RLY OPEN	B28
D	A-4	CH. 12 GREEN	12G-A	D	B-4	CH. 12 RED	B40
E	A-5	CH. 11 GREEN	11G-A	E	B-5	CH. 11 RED	B39
F	A-6	CH. 10 GREEN	10G-A	F	B-6	CH. 9 RED	B37
G	A-7	CH. 9 GREEN	9G-A	G	B-7	CH. 8 RED	8R-A
H	A-8	CH. 8 GREEN	8G-A	H	B-8	CH. 7 RED	7R-A
J	A-9	CH. 7 GREEN	7G-A	J	B-9	CH. 6 RED	6R-A
K	A-10	CH. 6 GREEN	6G-A	K	B-10	CH. 5 RED	5R-A
L	A-11	CH. 5 GREEN	5G-A	L	B-11	CH. 4 RED	4R-A
M	A-12	CH. 4 GREEN	4G-A	M	B-12	CH. 2 RED	2R-A
N	A-13	CH. 3 GREEN	3G-A	N	B-13	CH. 1 RED	1R-A
P	A-14	CH. 2 GREEN	2G-A	P	B-14	(SPARE 1)	B29
R	A-15	CH. 1 GREEN	1G-A	R	B-15	+24V MONITOR II	B-3
S	A-16	+24V MON. I	B-4	S	B-16	(SPARE 2)	B30
T	A-17	LOGIC GND	B-14	T	B-17	CH. 13 RED	13R-A
U	A-18	CHASSIS GND	LS7-2	U	B-18	S. DLY RLY CLSD	J3-35
V	A-19	AC- (COMMON)	K1-2	V	B-19	CH. 10 RED	B38
W	A-20	OUT RLY 1 COM.	J3-7	W	B-20	CH. 14 RED	14R-A
X	A-21	OUT RLY 2 COM.	A-27	X	B-21	CH. 15 RED	15R-A
Y	A-22	CH. 12 YELLOW	-T-	Y	B-22	CH. 16 RED	16R-A
Z	A-23	CH. 11 YELLOW	-T-	Z	B-23	CH. 3 RED	3R-A
a	A-24	CH. 10 WALK	----	a	B-24	RED ENABLE	LS8-1
b	A-25	CH. 10 YELLOW	-T-	b	B-25	(SPARE 3)	B31
c	A-26	CH. 9 YELLOW	-T-	c	B-26	LOCAL FLASH IN	CAPPED
d	A-27	CH. 8 YELLOW	8Y-A		B-27	SHELL GROUND	LS6-2
e	A-28	CH. 7 YELLOW	7Y-A				
f	A-29	CH. 6 YELLOW	6Y-A				
g	A-30	CH. 5 YELLOW	5Y-A				
h	A-31	CH. 3 YELLOW	3Y-A				
i	A-32	CH. 15 GREEN	15G-A				
j	A-33	CH. 2 YELLOW	2Y-A				
k	A-34	CH. 1 YELLOW	1Y-A				
m	A-35	CONT. VOLT. MON.	B-5				
n	A-36	+24V MON. INH.	B-2				
p	A-37	OUT RLY 1 CLSD	J3-3				
q	A-38	OUT RLY 2 OPEN	A-31				
r	A-39	CH. 12 WALK	----				
s	A-40	CH. 11 WALK	----				
t	A-41	CH. 9 WALK	----				
u	A-42	CH. 16 YELLOW	16Y-A				
v	A-43	CH. 15 YELLOW	15Y-A				
w	A-44	CH. 13 YELLOW	13Y-A				
x	A-45	CH. 4 YELLOW	4Y-A				
y	A-46	CH. 14 GREEN	14G-A				
z	A-47	CH. 13 GREEN	13G-A				
AA	A-48	(SPARE 1)	B24				
BB	A-49	RESET	B-1				
CC	A-50	CAB. INTLK A	B25				
DD	A-51	CAB. INTLK B	B26				
EE	A-52	CH. 14 YELLOW	14Y-A				
FF	A-53	CH. 16 GREEN	16G-A				
GG	A-54	(SPARE 2)	B27				
HH	A-55	TYPE SELECT	A-20				
	A-56	SHELL GND	LS15-2				

NOTES FOR 16 CHANNEL M.M.U.

- (1) RELAY CONTACT POSITIONS SPECIFIED ARE FOR NON-CONFLICT MODE.
- (2) TO PROGRAM MMU, SOLDER JUMPERS IN PROGRAMMING CARD FOR ALL PERMISSABLE PHASE MOVEMENTS, MINIMUM CHANGE DISABLE FOR ALL PEDESTRIAN CHANNELS, AND MIN. FLASH, VOLTAGE MON., AND 24V. MON. LATCH OPTIONS AS DESIRED.

M.M.U. CHANNEL ASSIGNMENTS

CH. 1 = L/S 1 = ^1 VEH.	CH. 1 = L/S 1 = ^1 VEH.
CH. 2 = L/S 2 = ^2 VEH.	CH. 2 = L/S 2 = ^2 VEH.
CH. 3 = L/S 3 = ^3 VEH.	CH. 3 = L/S 3 = ^3 VEH.
CH. 4 = L/S 4 = ^4 VEH.	CH. 4 = L/S 4 = ^4 VEH.
CH. 5 = L/S 5 = ^5 VEH.	CH. 5 = L/S 5 = ^5 VEH.
CH. 6 = L/S 6 = ^6 VEH.	CH. 6 = L/S 6 = ^6 VEH.
CH. 7 = L/S 7 = ^7 VEH.	CH. 7 = L/S 7 = ^7 VEH.
CH. 8 = L/S 8 = ^8 VEH.	CH. 8 = L/S 8 = ^8 VEH.
CH. 9 = L/S 9 = ^2 PED.	CH. 9 = L/S 9 = ^2 PED.
CH. 10 = L/S 10 = ^4 PED.	CH. 10 = L/S 10 = ^4 PED.
CH. 11 = L/S 11 = ^6 PED.	CH. 11 = L/S 11 = ^6 PED.
CH. 12 = L/S 12 = ^8 PED.	CH. 12 = L/S 12 = ^8 PED.
CH. 13 = L/S 13 = OLAP A	CH. 13 = L/S 13 = OLAP A
CH. 14 = L/S 14 = OLAP B	CH. 14 = L/S 14 = OLAP B
CH. 15 = L/S 15 = OLAP C	CH. 15 = L/S 15 = OLAP C
CH. 16 = L/S 16 = OLAP D	CH. 16 = L/S 16 = OLAP D

MMU PROGRAM CARD

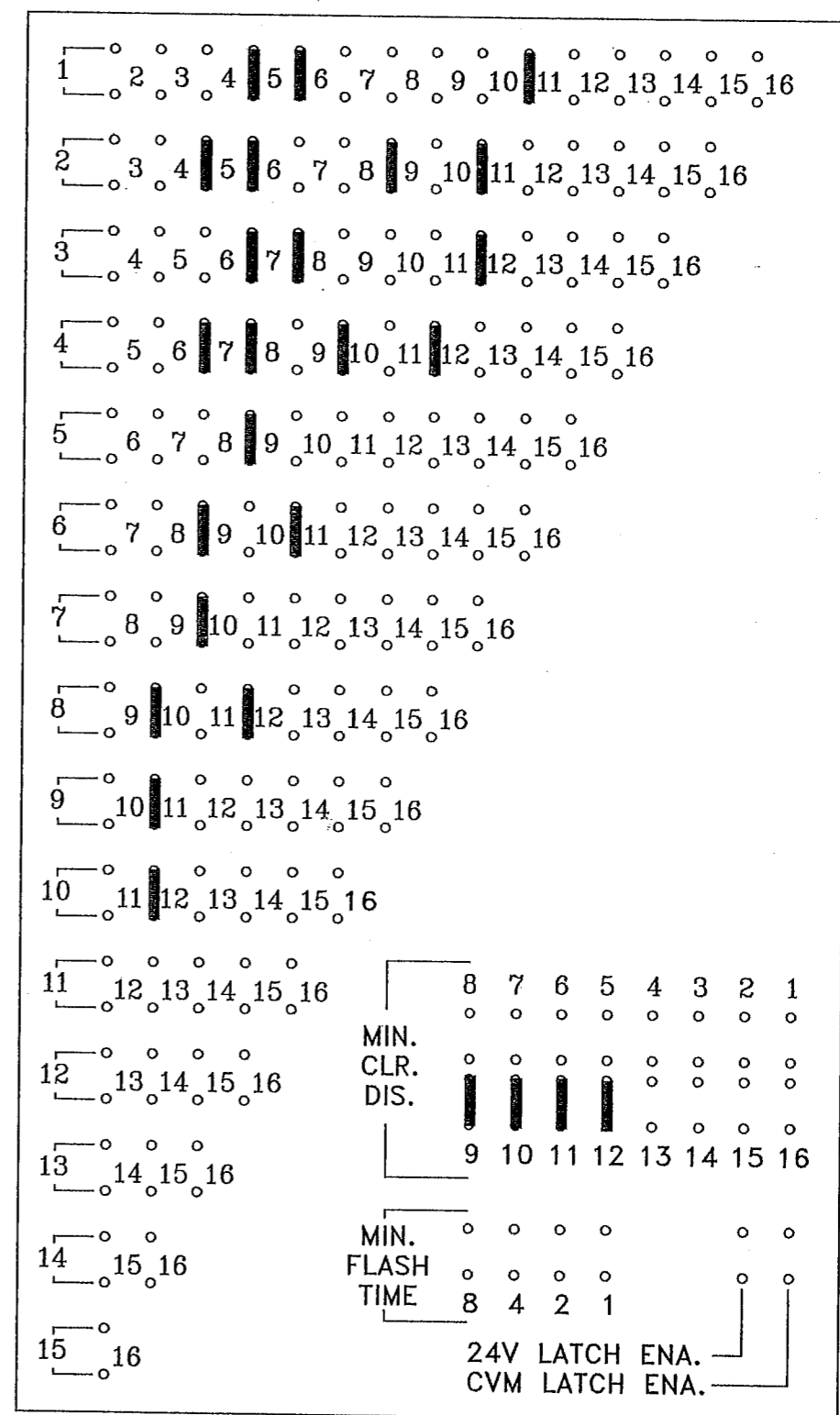

DETECTOR RACK 34030G1

POWER SUPPLY OR B.I.U.	L3	L1	L7	L5	L11	L9	L15	L13	PMT 5 3-8	PMT 3 1-6	PGM. CARD
	5-1	1-1	2-3	2-1	2-5	6-1	6-5	6-3	<input type="checkbox"/> 2CH OPTICOM/ OPIC CH. C CH. D 4-7	<input type="checkbox"/> 4CH <input type="checkbox"/> 2CH OPTICOM/ OPIC CH. A CH. B 2-5	
	<input type="checkbox"/> 2CH 5-2	<input type="checkbox"/> 2CH 1-2	<input type="checkbox"/> 2CH 2-4	<input type="checkbox"/> 2CH 2-2	<input type="checkbox"/> 2CH ∅	<input type="checkbox"/> 2CH 6-2	<input type="checkbox"/> 2CH ∅	<input type="checkbox"/> 2CH 6-4	<input type="checkbox"/> 2CH 6-4		
	L4	L2	L8	L6	L12	L10	L16	L14	PMT 6	PMT 4	

J13 C/C 33284G10 DC POWER	J16 C/C 33284G8 EXP. OUTPUTS	J14 C/C 33284G2 LPS 1-8	J18 C/C 33284G9 SYS. OUTPUTS	J15 C/C 33284G3 LPS 9-16	J17 C/C 33284G6 AC POWER	J19 C/C 33284G17 PGM. CARD
---------------------------------	------------------------------------	-------------------------------	------------------------------------	--------------------------------	--------------------------------	----------------------------------

①

ADDRESS TABLE					
RACK #	JMPR	DET. #'S	RACK #	JMPR	DET. #'S
1	⊙⊙⊙	1-16	5	⊙⊙⊙	65-80
2	⊙⊙⊙	17-32	6	⊙⊙⊙	81-96
3	⊙⊙⊙	33-48	7	⊙⊙⊙	97-112
4	⊙⊙⊙	49-64	8	⊙⊙⊙	113-128

DETECTOR ASSIGNMENTS		
CONT. INPUT	PHASE ASGN.	DETECTOR TYPE
1	1-1	1
2	1-2	1
3	5-1	1
4	5-2	1
5	2-1	1
6	2-2	1
7	2-3	1
8	2-4	1
9	6-1	1
10	6-2	1
11	2-5	1
12		
13	6-3	1
14	6-4	1
15	6-5	1
16		
17	3-1	1
18	3-2	1
19	7-1	1
20	7-2	1
21	4-1	1
22	4-2	1
23	4-3	1
24	4-4	1
25	8-1	1
26	8-2	1
27	4-5	1
28		
29	8-3	1
30	8-4	1
31	8-5	1
32		
33		
34		
35		
36		

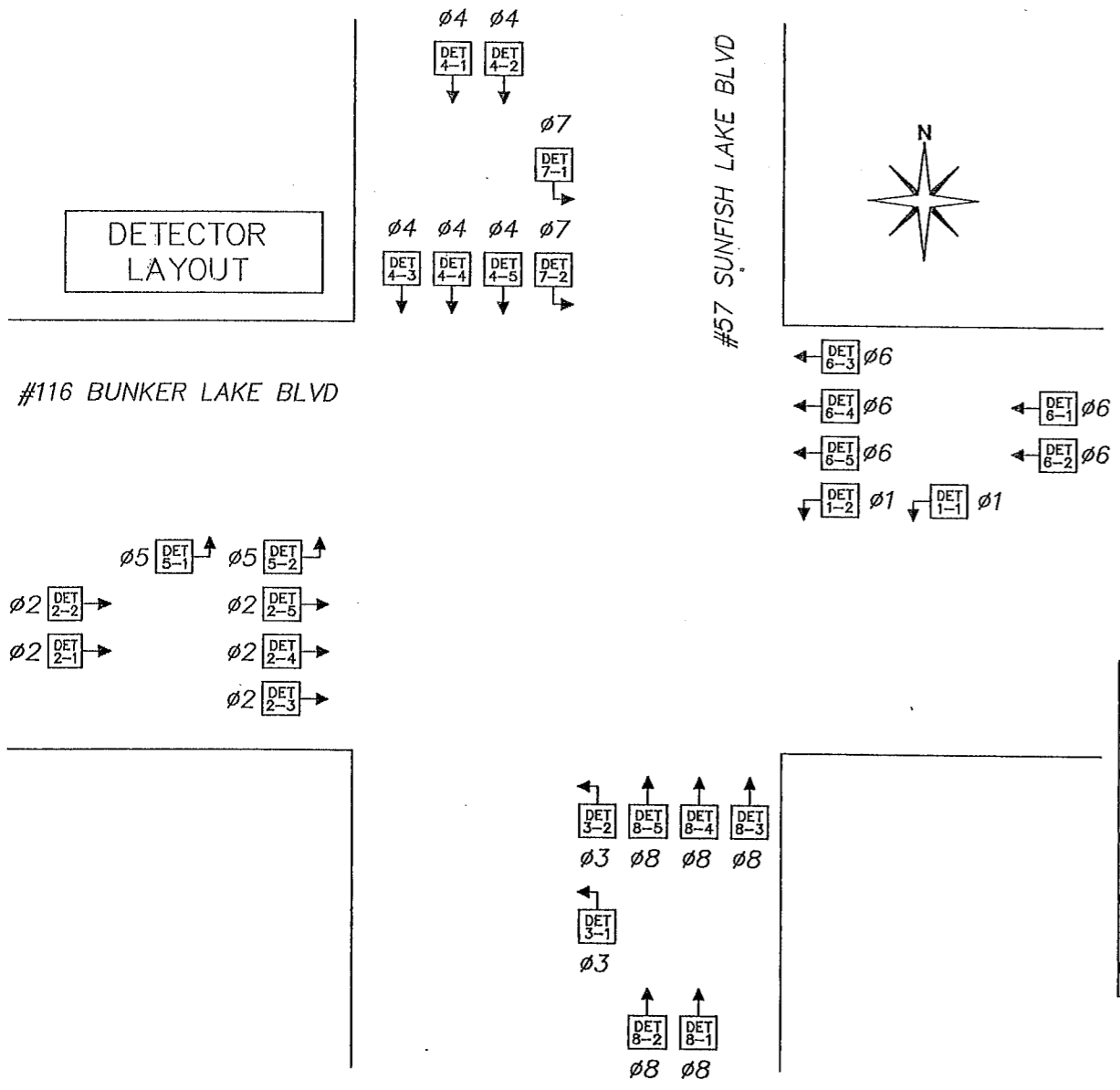

DETECTOR RACK PROGRAMMING JUMPERS																													
DET. TYPE	JP1	JP2	SLOT 1/2 ①					SLOT 3/4 ①					SLOT 5/6 ①					SLOT 7/8 ①											
			JP3	JP4	JP5	JP6	JP7	JP8	JP9	JP10	JP11	JP12	JP13	JP14	JP15	JP16	JP17	JP18	JP19	JP20	JP21	JP22	JP23	JP24	JP25	JP26	JP27	JP28	JP29
① TS-1	NO	NO	⊙	⊙	⊙	⊙	⊙	⊙	⊙	⊙	⊙	⊙	⊙	⊙	⊙	⊙	⊙	⊙	⊙	⊙	⊙	⊙	⊙	⊙	⊙	⊙	⊙	⊙	⊙
② TS-2	YES	YES	⊙	⊙	⊙	⊙	⊙	⊙	⊙	⊙	⊙	⊙	⊙	⊙	⊙	⊙	⊙	⊙	⊙	⊙	⊙	⊙	⊙	⊙	⊙	⊙	⊙	⊙	⊙
③ LM-632T 262-FC	NO	NO	⊙	⊙	⊙	⊙	⊙	⊙	⊙	⊙	⊙	⊙	⊙	⊙	⊙	⊙	⊙	⊙	⊙	⊙	⊙	⊙	⊙	⊙	⊙	⊙	⊙	⊙	⊙
④ MAG.	NO	NO	⊙	⊙	⊙	⊙	⊙	⊙	⊙	⊙	⊙	⊙	⊙	⊙	⊙	⊙	⊙	⊙	⊙	⊙	⊙	⊙	⊙	⊙	⊙	⊙	⊙	⊙	⊙

DETECTOR LOOP
INTERFACE
ASSY. 34040G1

J1
TO DR1: J14
C/C 33284G2

J2
TO DR1: J15
C/C 33284G3

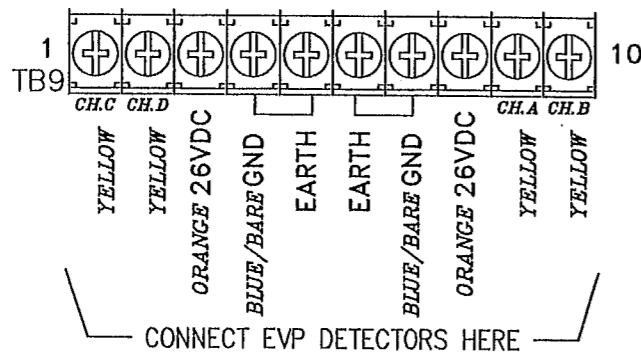
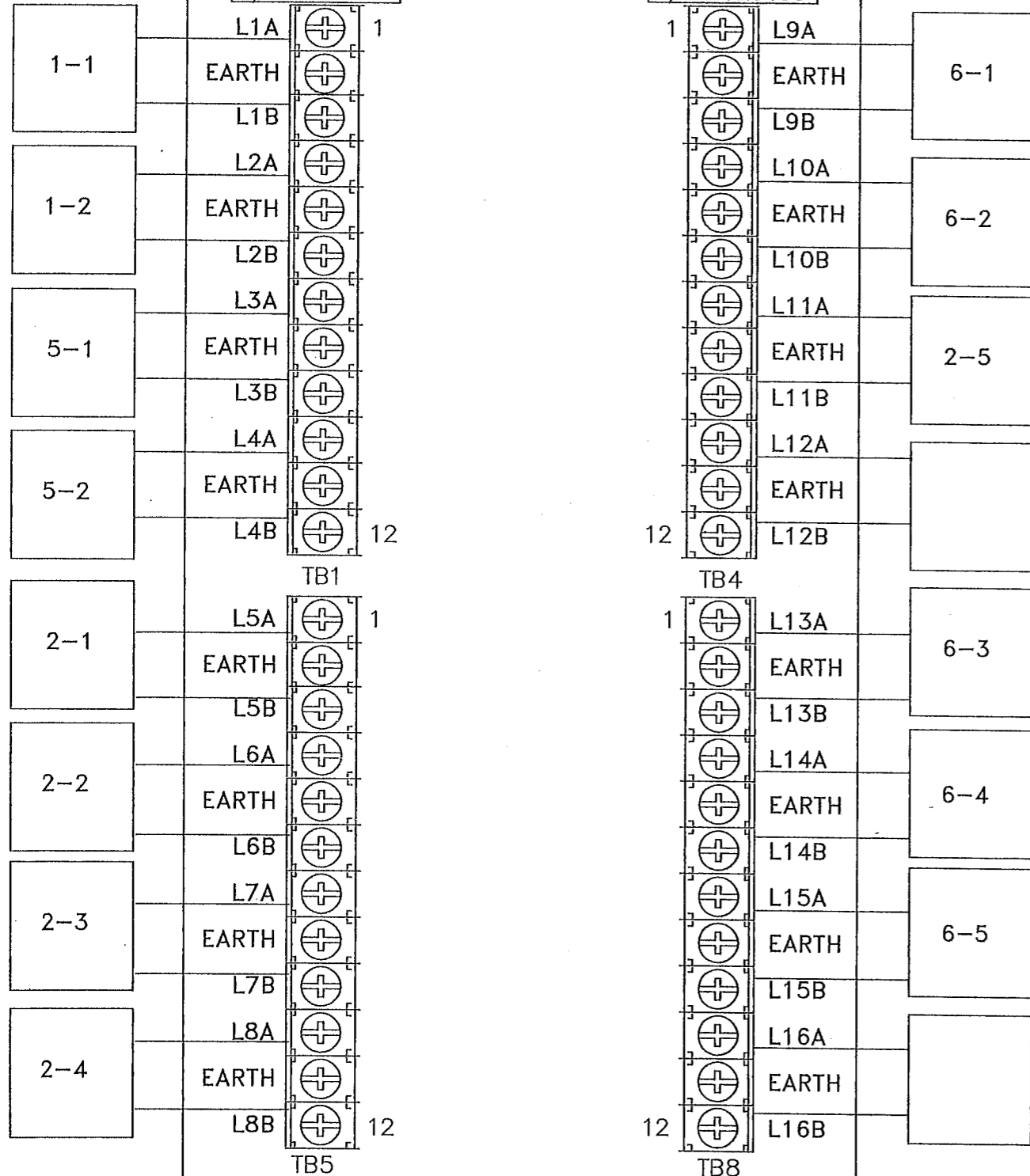

DET. LOOPS 9-16 (J15) C/C 33284G3

PIN	SIGNAL	TO
1	LOOP 9+	LPI2: TB4-1
2	LOOP 9-	LPI2: TB4-3
3	LOOP 10+	LPI2: TB4-4
4	LOOP 10-	LPI2: TB4-6
5	LOOP 11+	LPI2: TB4-7
6	LOOP 11-	LPI2: TB4-9
7	LOOP 12+	LPI2: TB4-10
8	LOOP 12-	LPI2: TB4-12
9	LOOP 13+	LPI2: TB8-1
10	LOOP 13-	LPI2: TB8-3
11	LOOP 14+	LPI2: TB8-4
12	LOOP 14-	LPI2: TB8-6
13	LOOP 15+	LPI2: TB8-7
14	LOOP 15-	LPI2: TB8-9
15	LOOP 16+	LPI2: TB8-10
16	LOOP 16-	LPI2: TB8-12
17	----	
18	----	
19	----	
20	----	

DET. RACK POWER C/C 34842G5			
P1/ DR: J13	P2/ DR: J17	FUNCTION	TO
1		+12 VDC (DET. POWER)	PB-3
2		+24 VDC (BIU POWER)	PB-2
3		LOGIC GROUND	PB-1
4		EARTH GROUND	PB-9
5		"KEY PIN"	
6		LINE FREQUENCY REF.	PB-5
	1	EARTH GROUND	----
	2	AC LINE	PB-12
	3	AC NEUTRAL	PB-10
	4	LOGIC GROUND	----

DET. LOOPS 1-8 (J14) C/C 33284G2

PIN	SIGNAL	TO
1	LOOP 1+	LPI1: TB1-1
2	LOOP 1-	LPI1: TB1-3
3	LOOP 2+	LPI1: TB1-4
4	LOOP 2-	LPI1: TB1-6
5	LOOP 3+	LPI1: TB1-7
6	LOOP 3-	LPI1: TB1-9
7	LOOP 4+	LPI1: TB1-10
8	LOOP 4-	LPI1: TB1-12
9	LOOP 5+	LPI1: TB5-1
10	LOOP 5-	LPI1: TB5-3
11	LOOP 6+	LPI1: TB5-4
12	LOOP 6-	LPI1: TB5-6
13	LOOP 7+	LPI1: TB5-7
14	LOOP 7-	LPI1: TB5-9
15	LOOP 8+	LPI1: TB5-10
16	LOOP 8-	LPI1: TB5-12
17	PMT. DET. CH. C	LPI1: TB9-1
18	PMT. DET. CH. D	LPI1: TB9-2
19	KEY PIN	
20	PMT. CH. C/D +26VDC	LPI1: TB9-3
21	PMT. DC GROUND	LPI1: TB9-4,7
22	PMT. CH. A/B +26VDC	LPI1: TB9-8
23	PMT. DET. CH. A	LPI1: TB9-9
24	PMT. DET. CH. B	LPI1: TB9-10
25	----	
26	----	

EXPANSION OUTPUTS C/C 33284G8		
J16	FUNCTION	TO
17	DET. 17 / PMT. A OUT	MP: B19
18	DET. 18 / PMT. B OUT	MP: B20
19	PMT. C OUT	MP: B17
20	PMT. D OUT	MP: B18

DETECTOR LOOP INTERFACE

DETECTOR RACK 34030G1

POWER SUPPLY OR B.I.U.	L19	L17	L23	L21	L27	L25	L31	L29			PGM. CARD
	7-1	3-1	4-3	4-1	4-5	8-1	8-5	8-3			
	□ 2CH 7-2	□ 2CH 3-2	□ 2CH 4-4	□ 2CH 4-2	□ 2CH ∅	□ 2CH 8-2	□ 2CH ∅	□ 2CH 8-4			
	L20	L18	L24	L22	L28	L26	L32	L30			
J13 C/C 33284G10 DC POWER	J16 C/C 33284G8 EXP. OUTPUTS	J14 C/C 33284G2 LPS 1-8	J18 C/C 33284G9 SYS. OUTPUTS	J15 C/C 33284G3 LPS 9-16	J17 C/C 33284G6 AC POWER	J19 C/C 33284G17 PGM. CARD					

②

ADDRESS TABLE					
RACK #	JMPR	DET. #'S	RACK #	JMPR	DET. #'S
1	⊙ ⊙ ⊙	1-16	5	⊙ ⊙ ⊙	65-80
2	⊙ ⊙ ⊙	17-32	6	⊙ ⊙ ⊙	81-96
3	⊙ ⊙ ⊙	33-48	7	⊙ ⊙ ⊙	97-112
4	⊙ ⊙ ⊙	49-64	8	⊙ ⊙ ⊙	113-128

DETECTOR ASSIGNMENTS		
CONT. INPUT	PHASE ASGN.	DETECTOR TYPE
1	1-1	1
2	1-2	1
3	5-1	1
4	5-2	1
5	2-1	1
6	2-2	1
7	2-3	1
8	2-4	1
9	6-1	1
10	6-2	1
11	2-5	1
12		
13	6-3	1
14	6-4	1
15	6-5	1
16		
17	3-1	1
18	3-2	1
19	7-1	1
20	7-2	1
21	4-1	1
22	4-2	1
23	4-3	1
24	4-4	1
25	8-1	1
26	8-2	1
27	4-5	1
28		
29	8-3	1
30	8-4	1
31	8-5	1
32		
33		
34		
35		
36		

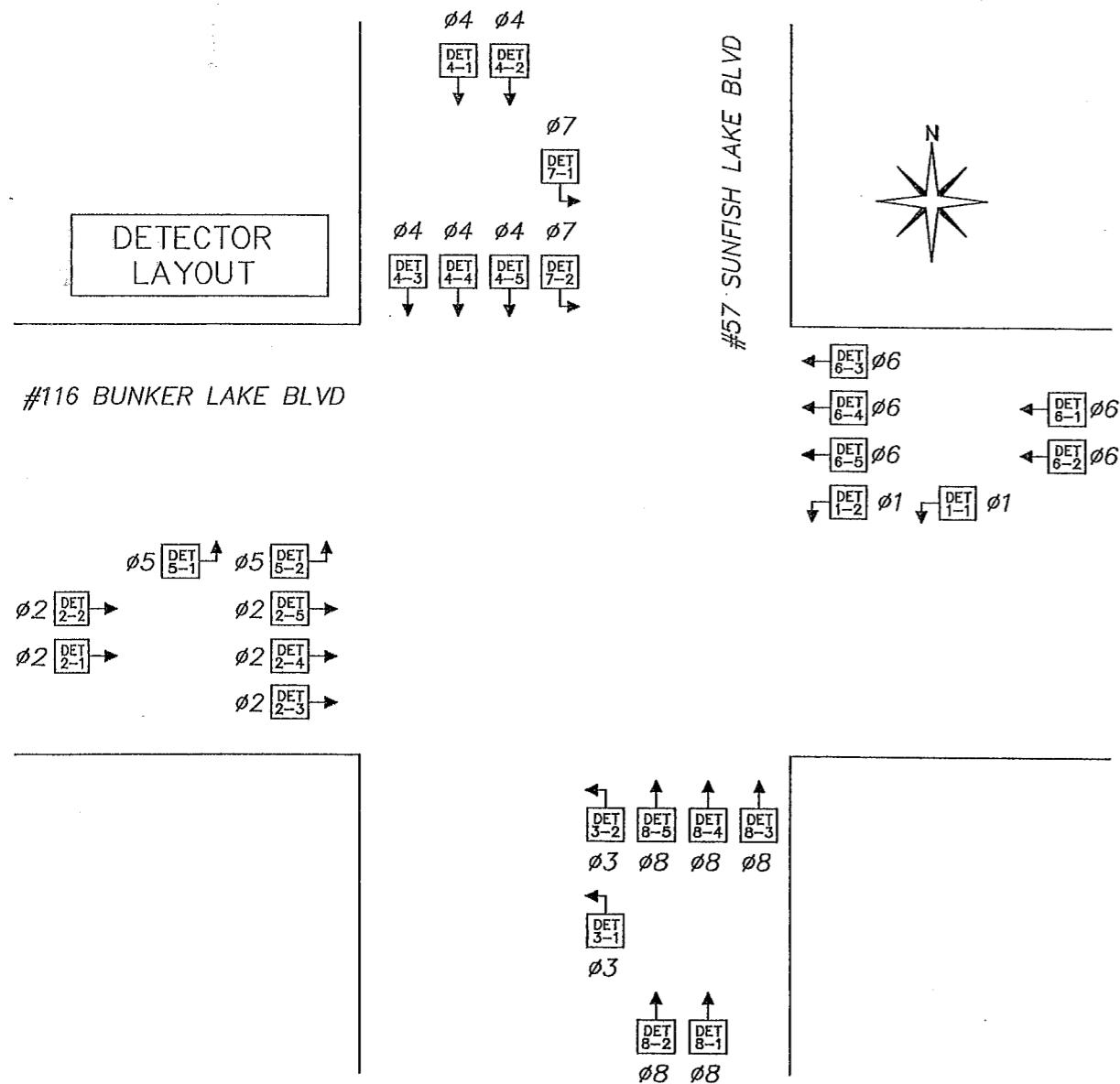

DET. TYPE		DETECTOR RACK PROGRAMMING JUMPERS																											
		JP1	JP2	SLOT 1/2 ①				SLOT 3/4 ①				SLOT 5/6 ①				SLOT 7/8 ①													
		JP3	JP4	JP5	JP6	JP7	JP8	JP9	JP10	JP11	JP12	JP13	JP14	JP15	JP16	JP17	JP18	JP19	JP20	JP21	JP22	JP23	JP24	JP25	JP26	JP27	JP28	JP29	JP30
①	TS-1	NO	NO	⊙	⊙	⊙	⊙	⊙	⊙	⊙	⊙	⊙	⊙	⊙	⊙	⊙	⊙	⊙	⊙	⊙	⊙	⊙	⊙	⊙	⊙	⊙	⊙	⊙	
②	TS-2	YES	YES	⊙	⊙	⊙	⊙	⊙	⊙	⊙	⊙	⊙	⊙	⊙	⊙	⊙	⊙	⊙	⊙	⊙	⊙	⊙	⊙	⊙	⊙	⊙	⊙	⊙	
③	LM-632T 262-FC	NO	NO	⊙	⊙	⊙	⊙	⊙	⊙	⊙	⊙	⊙	⊙	⊙	⊙	⊙	⊙	⊙	⊙	⊙	⊙	⊙	⊙	⊙	⊙	⊙	⊙	⊙	
④	MAG.	NO	NO	⊙	⊙	⊙	⊙	⊙	⊙	⊙	⊙	⊙	⊙	⊙	⊙	⊙	⊙	⊙	⊙	⊙	⊙	⊙	⊙	⊙	⊙	⊙	⊙	⊙	

DETECTOR LOOP
INTERFACE
ASSY. 34040G1

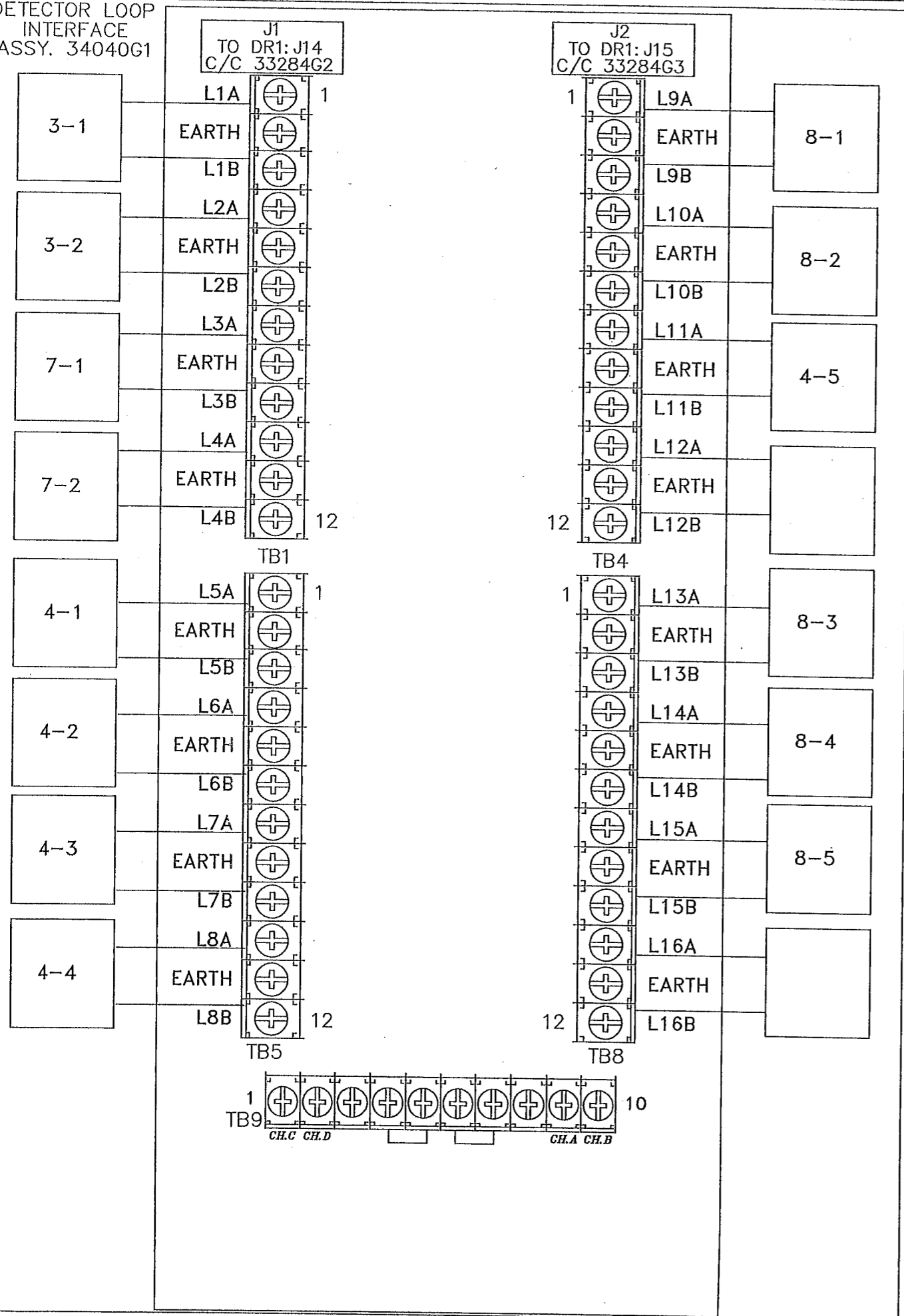

DET. LOOPS 9-16 (J15) C/C 33284G3

PIN	SIGNAL	TO
1	LOOP 9+	LPI2: TB4-1
2	LOOP 9-	LPI2: TB4-3
3	LOOP 10+	LPI2: TB4-4
4	LOOP 10-	LPI2: TB4-6
5	LOOP 11+	LPI2: TB4-7
6	LOOP 11-	LPI2: TB4-9
7	LOOP 12+	LPI2: TB4-10
8	LOOP 12-	LPI2: TB4-12
9	LOOP 13+	LPI2: TB8-1
10	LOOP 13-	LPI2: TB8-3
11	LOOP 14+	LPI2: TB8-4
12	LOOP 14-	LPI2: TB8-6
13	LOOP 15+	LPI2: TB8-7
14	LOOP 15-	LPI2: TB8-9
15	LOOP 16+	LPI2: TB8-10
16	LOOP 16-	LPI2: TB8-12
17	----	
18	----	
19	----	
20	----	

DET. RACK POWER C/C 34842G5			
P1/ DR: J13	P2/ DR: J17	FUNCTION	TO
1		+12 VDC (DET. POWER)	PB-3
2		+24 VDC (BIU POWER)	PB-2
3		LOGIC GROUND	PB-1
4		EARTH GROUND	PB-9
5		"KEY PIN"	
6		LINE FREQUENCY REF.	PB-5
	1	EARTH GROUND	----
	2	AC LINE	PB-12
	3	AC NEUTRAL	PB-10
	4	LOGIC GROUND	----

DET. LOOPS 1-8 (J14) C/C 33284G2

PIN	SIGNAL	TO
1	LOOP 1+	LPI1: TB1-1
2	LOOP 1-	LPI1: TB1-3
3	LOOP 2+	LPI1: TB1-4
4	LOOP 2-	LPI1: TB1-6
5	LOOP 3+	LPI1: TB1-7
6	LOOP 3-	LPI1: TB1-9
7	LOOP 4+	LPI1: TB1-10
8	LOOP 4-	LPI1: TB1-12
9	LOOP 5+	LPI1: TB5-1
10	LOOP 5-	LPI1: TB5-3
11	LOOP 6+	LPI1: TB5-4
12	LOOP 6-	LPI1: TB5-6
13	LOOP 7+	LPI1: TB5-7
14	LOOP 7-	LPI1: TB5-9
15	LOOP 8+	LPI1: TB5-10
16	LOOP 8-	LPI1: TB5-12
17	PMT. DET. CH. C	LPI1: TB9-1
18	PMT. DET. CH. D	LPI1: TB9-2
19	KEY PIN	
20	PMT. CH. C/D +26VDC	LPI1: TB9-3
21	PMT. DC GROUND	LPI1: TB9-4,7
22	PMT. CH. A/B +26VDC	LPI1: TB9-8
23	PMT. DET. CH. A	LPI1: TB9-9
24	PMT. DET. CH. B	LPI1: TB9-10
25	----	
26	----	

EXPANSION OUTPUTS C/C 33284G8		
J16	FUNCTION	TO
17	DET. 17 / PMT. A OUT	MP: B19
18	DET. 18 / PMT. B OUT	MP: B20
19	PMT. C OUT	MP: B17
20	PMT. D OUT	MP: B18

DETECTOR LOOP INTERFACE

B.I.U	DET	PH	F	DET	DLY	EXT	DET	PH	F	DET	DLY	EXT	DET	PH	F	DET	DLY	EXT	DET	PH	F	DET	DLY	EXT	EVP	PH	POLE #	CONT CH #
	CH 1	1		1-1			CH 5	2		2-1			CH 9	6		6-1			CH 13			6-3			CH 1	1-6	3	3
	CH 2	1		1-2			CH 6	2		2-2			CH 10	6		6-2			CH 14			6-4			CH 2	2-5	1	4
	CH 3	5		5-1			CH 7	2		2-3			CH 11	2		2-5			CH 15			6-5			CH 3	3-8	4	5
	CH 4	5		5-2			CH 8	2		2-4			CH 12						CH 16						CH 4	4-7	2	6

B.I.U	DET	PH	F	DET	DLY	EXT	DET	PH	F	DET	DLY	EXT	DET	PH	F	DET	DLY	EXT	DET	PH	F	DET	DLY	EXT				
	CH 17	3		3-1			CH 21	4		4-1			CH 25	8		8-1			CH 29	8		8-3						
	CH 18	3		3-2			CH 22	4		4-2			CH 26	8		8-2			CH 30	8		8-4						
	CH 19	7		7-1			CH 23	4		4-3			CH 27	4		4-5			CH 31	8		8-5						
	CH 20	7		7-2			CH 24	4		4-4			CH 28						CH 32									

EVP SENSORS

CABLE	DISCR. CHAN.	PHASES	POLE#	TERMINAL TB9		
				SIGNAL	DC(+)	GND
37	1	1-6	3	9	8	7
44	2	2-5	1	10	8	7
58	3	3-8	4	1	3	4
21	4	4-7	2	2	3	4

VEHICLE SIGNALS

CABLE	SIGNAL	TERMINAL						
		G	FYA	Y	R	G	Y	R
33	1-1	1	51	5	7			
17	1-2	2	52	6	8			
38	2-1					9	11	13
39	2-2					10	12	14
54	3-1	15	57	19	21			
33	3-2	16	58	20	22			
15	4-1					23	25	27
16	4-2					24	26	28
40	5-1	29	63	33	35			
54	5-2	30	64	34	36			
31	6-1					37	39	41
32	6-2					38	40	42
17	7-1	43	69	47	49			
40	7-2	44	70	48	50			
52	8-1					51	53	55
53	8-2					52	54	56

EVP VERIFY LIGHTS

CABLE	CONTR. CHAN.	PHASES	POLE#	TERM.
36	3	1-6	3	59
43	4	2-5	1	65
57	5	3-8	4	71
20	6	4-7	2	77

VEH DETECTORS

CABLE	DET	SLOT	FUNC	RACK	TERMINAL
45	1-1	1	3	1	L1
46	1-2	2	3	1	L2
25	2-1	3	1	1	L3
26	2-2	4	1	1	L4
23	2-3	5	3	1	L5
24	2-4	6	1	1	L6
28	2-5	11	1	1	L11
12	3-1	17	1	2	L1
13	3-2	18	1	2	L2
65	4-1	21	3,8	2	L5
66	4-2	22	3,8	2	L6
29	4-3	23	7	2	L7
30	4-4	24	1	2	L8
50	4-5	27	1	2	L11
51	5-1	3	1	1	L3
48	5-2	4	1	1	L4
49	6-1	9	1	1	L9
60	6-2	10	1	1	L10
61	6-3	13	7	1	L13
10	6-4	14	1	1	L14
11	6-5	15	1	1	L15
8	7-1	19	1	2	L3
12	7-2	20	1	2	L4
10	8-1	25	3,8	2	L9
11	8-2	26	3,8	2	L10
8	8-3	29	7	2	L13
9	8-4	30	1	2	L14
14	8-5	31	1	2	L15

PED PUSHBUTTONS

CABLE	PPB	TERMINAL	RETURN
18	2-1	PC2	GB1
41	2-2	PC2	GB1
34	4-1	PC4	GB1
19	4-2	PC4	GB1
55	6-1	PC6	GB1
35	6-2	PC6	GB1
42	8-1	PC8	GB1
56	8-2	PC8	GB1

PED SIGNALS

CABLE	SIGNAL	TERMINAL	
		WK	DW
16	2-1	49	53
39	2-2	50	54
32	4-1	55	59
16	4-2	56	60
53	6-1	61	65
32	6-2	62	66
39	8-1	67	71
53	8-2	68	72