

# AUTUMN HEIGHTS 2ND ADDITION

CITY OF RAMSEY  
ANOKA COUNTY, MINNESOTA

KNOW ALL MEN BY THESE PRESENTS: That the County of Anoka, a political subdivision, owner and proprietor of the following described property situated in the County of Anoka, State of Minnesota to wit:

Lot 1, Block 3, Autumn Heights, according to the recorded plat thereof.

Has caused the same to be surveyed and platted as AUTUMN HEIGHTS 2ND ADDITION and does hereby donate and dedicate to the public for public use forever Parcel 63, Anoka County Highway Right-of-Way Plat No. 33. Also dedicating the utility and drainage easements as shown on the plat.

In witness whereof said County of Anoka, a political subdivision, has caused these presents to be signed by its proper officers this 10<sup>th</sup> day of July, 1990.

SIGNED: County of Anoka  
By: Dan Erhart County Board Chairman Attest: John Jay McLinden County Administrator

STATE OF MINNESOTA  
COUNTY OF ANOKA  
The foregoing instrument was acknowledged before me this 10<sup>th</sup> day of July, 1990, by Dan Erhart, County Board Chairman of the County of Anoka, a political subdivision, on behalf of the political subdivision.

Patsy Elliott  
Notary Public, Anoka County, Minnesota  
My Commission Expires January 1, 1991

STATE OF MINNESOTA  
COUNTY OF ANOKA  
The foregoing instrument was acknowledged before me this 10<sup>th</sup> day of July, 1990, by John Jay McLinden, County Administrator of the County of Anoka, a political subdivision, on behalf of the political subdivision.

Patsy Elliott  
Notary Public, Anoka County, Minnesota  
My Commission Expires January 1, 1991

I hereby certify that I have surveyed and platted the property described on this plat as AUTUMN HEIGHTS 2ND ADDITION; that this plat is a correct representation of said survey; that all distances are correctly shown on said plat in feet and hundredths of a foot; that all monuments have been correctly placed in the ground as shown on said plat; that the outside boundary lines are correctly designated on said plat and that there are no wet lands or public highways to be designated on said plat other than as shown.

Merlyn D. Anderson  
Merlyn D. Anderson, Registered Land Surveyor  
Minnesota Registration No. 13596

STATE OF MINNESOTA  
COUNTY OF ANOKA  
The foregoing Surveyor's Certificate was acknowledged before me this 10<sup>th</sup> day of JULY, 1990, by Merlyn D. Anderson, Land Surveyor.

Larry D. Han  
Notary Public, Anoka County, Minnesota  
My Commission Expires Oct. 9, 1994

CITY OF RAMSEY  
We hereby certify that the City Council of the City of Ramsey, Anoka County, Minnesota, duly accepted and approved the plat of AUTUMN HEIGHTS 2ND ADDITION at a regular meeting held this 27<sup>th</sup> day of July, 1990. If applicable, the written comments and recommendations of the Commissioner of Transportation and the County Highway Engineer have been received by the city or the prescribed 30 day period has elapsed without receipt of such comments and recommendations, as provided by Minn. Statutes, Section 505.03, Subd. 2.

By: Joseph P. Remians Mayor Attest: Paul R. Hartz Clerk

This plat has been checked and approved this 27<sup>th</sup> day of July, 1990.  
Merlyn D. Anderson  
Anoka County Surveyor

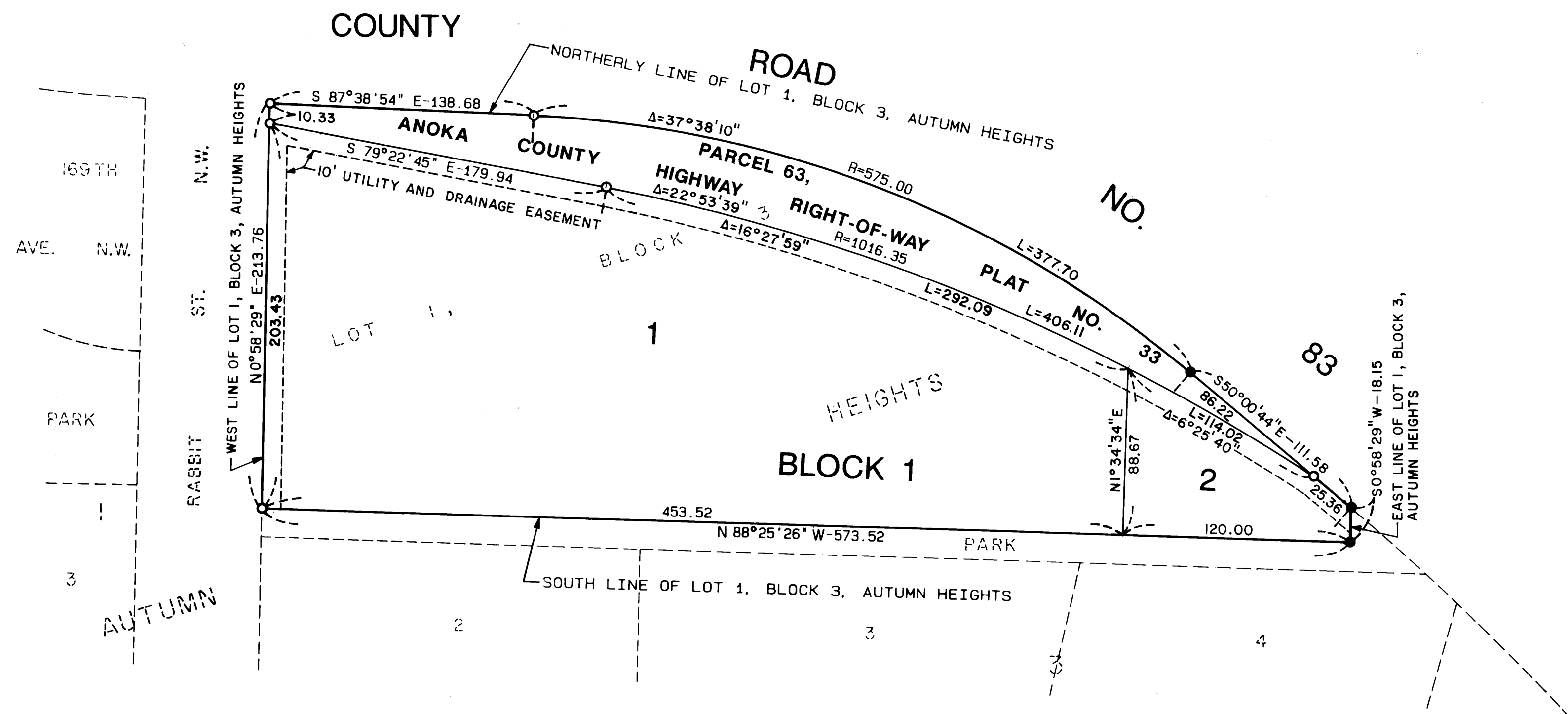
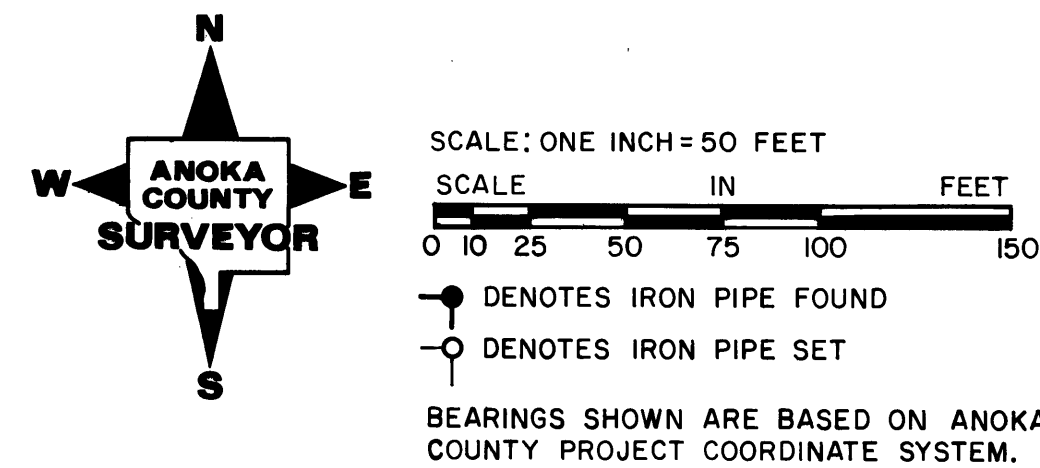

901612

901612  
JUL 27 1990  
11:15 AM  
42-5 Plats  
28  
Red O'Connell  
Debra Kay Ege

I HEREBY CERTIFY THAT THE TAXES PAYABLE IN THE YEAR 1990 ON THE LANDS DESCRIBED WITHIN ARE PAID  
Donald C. Bayless  
Anoka County Treasurer  
Lenny

"NO DELINQUENT TAXES AND TRANSFER ENTRIES"  
July 27, 1990  
Wendell A. Peterson  
Auditor, Anoka County  
Annika Schultz

CITY OF RAMSEY  
MUNICIPAL  
CORP.  
ANOKA COUNTY, MINN.