

# CAROL-ROSE ACRES

## TOWNSHIP OF RAMSEY

### ANOKA COUNTY, MINNESOTA

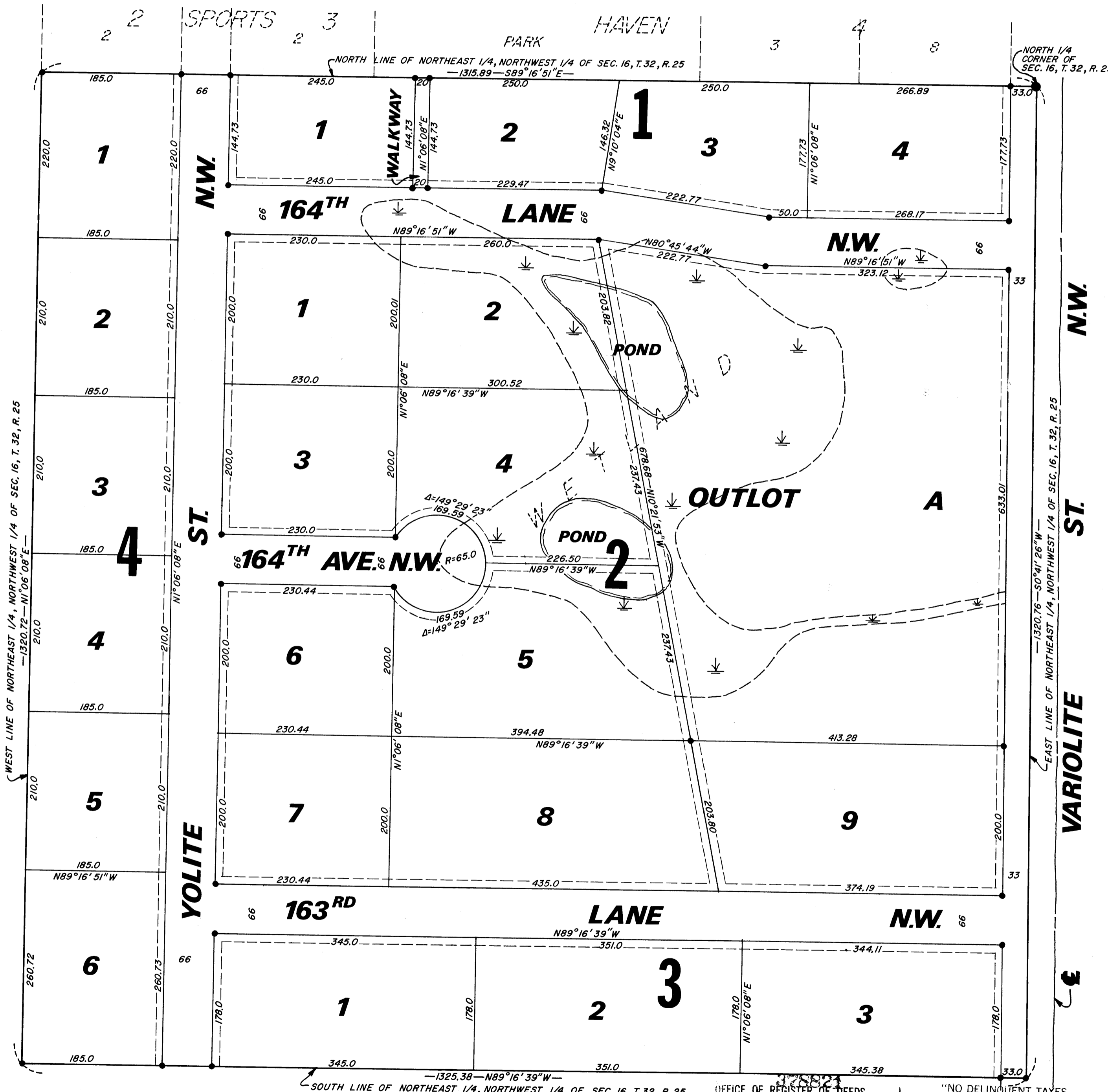
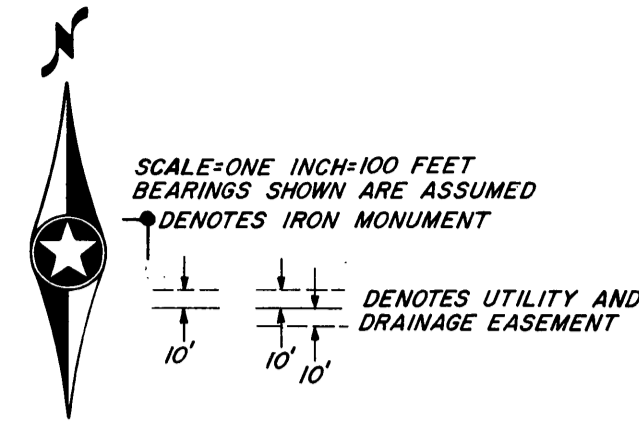

KNOW ALL MEN BY THESE PRESENTS: THAT L&S CO., A PARTNERSHIP CONSISTING OF KENNETH A. LASKA AND DENNIS E. SPRINGER, OWNERS AND PROPRIETORS, AND STATE BANK OF ANOKA, A MINNESOTA CORPORATION, MORTGAGEE, OF THE FOLLOWING DESCRIBED PROPERTY SITUATED IN THE COUNTY OF ANOKA AND STATE OF MINNESOTA TO-WIT: THE NORTHEAST 1/4 OF THE NORTHWEST 1/4 OF SECTION 16, TOWNSHIP 32, RANGE 25. WALKWAY. HAVE CAUSED THE SAME TO BE SURVEYED AND PLATTED AS CAROL-ROSE ACRES AND DO HEREBY DONATE AND DEDICATE TO THE PUBLIC FOR PUBLIC USE FOREVER THE LANES, AVENUE AND STREETS AS SHOWN ON THE PLAT. ALSO RESERVING THE EASEMENTS FOR UTILITY AND DRAINAGE PURPOSES AS SHOWN ON THE PLAT. IN WITNESS WHEREOF SAID KENNETH A. LASKA AND DENNIS E. SPRINGER, HAVE HEREUNTO SET THEIR HANDS AND SEALS ON THIS 21<sup>ST</sup> DAY OF SEPT. A.D. 1972. ALSO STATE BANK OF ANOKA HAS CAUSED THESE PRESENTS TO BE SIGNED BY ITS PROPER OFFICERS AND ITS CORPORATE SEAL TO BE AFFIXED ON THIS 25 DAY OF Sept A.D. 1972.

IN THE PRESENCE OF:

*Timothy J. Leh* AND *Bruce L. Stromgren*  
*Timothy J. Leh* AND *Bruce L. Stromgren*  
*Larry Baden* AND *Howard Priebe*  
*Larry Baden* AND *Stephen Schmidt*

SIGNED:  
L&S CO., A PARTNERSHIP  
BY *Kenneth A. Laska* PARTNER  
KENNETH A. LASKA  
BY *Dennis E. Springer* PARTNER  
DENNIS E. SPRINGER  
STATE BANK OF ANOKA  
BY *Henry C. Johnson* 1st VICE-PRESIDENT  
HENRY C. JOHNSON  
BY *Francis P. Meier* CASHIER  
FRANCIS P. MEIER

STATE OF MINNESOTA) ss  
COUNTY OF ANOKA) ON THIS 21<sup>ST</sup> DAY OF SEPT. A.D. 1972, BEFORE ME, A NOTARY PUBLIC, WITHIN AND FOR SAID COUNTY AND STATE, PERSONALLY APPEARED KENNETH A. LASKA AND DENNIS E. SPRINGER, TO ME PERSONALLY KNOWN, WHO BEING BY ME DULY SWORN, DID SAY THAT THEY ARE THE PARTNERS OF L&S CO., THE PARTNERSHIP NAMED IN THE FOREGOING INSTRUMENT; AND SAID KENNETH A. LASKA AND DENNIS E. SPRINGER ACKNOWLEDGE SAID INSTRUMENT TO BE THE FREE ACT AND DEED OF SAID PARTNERSHIP.

MY COMMISSION EXPIRES 6-23-1977

*Gail E. Schuette*  
NOTARY PUBLIC, ANOKA COUNTY, MINNESOTA

STATE OF MINNESOTA) ss  
COUNTY OF ANOKA) ON THIS 25 DAY OF SEPT. A.D. 1972, BEFORE ME, A NOTARY PUBLIC, WITHIN AND FOR SAID COUNTY AND STATE, PERSONALLY APPEARED HENRY C. JOHNSON AND FRANCIS P. MEIER, TO ME PERSONALLY KNOWN, WHO BEING BY ME DULY SWORN, DID SAY THAT THEY ARE THE 1st VICE-PRESIDENT AND CASHIER, RESPECTIVELY, OF STATE BANK OF ANOKA, THE CORPORATION NAMED IN THE FOREGOING INSTRUMENT; THAT THE SEAL AFFIXED TO SAID INSTRUMENT IS THE CORPORATE SEAL OF SAID CORPORATION; AND THAT SAID INSTRUMENT WAS SIGNED AND SEALED IN BEHALF OF SAID CORPORATION BY AUTHORITY OF ITS BOARD OF DIRECTORS, AND SAID HENRY C. JOHNSON AND FRANCIS P. MEIER, ACKNOWLEDGE SAID INSTRUMENT TO BE THE FREE ACT AND DEED OF SAID CORPORATION.

MY COMMISSION EXPIRES 6-23-1977

*Larry L. Baden*  
NOTARY PUBLIC, ANOKA COUNTY, MINNESOTA

I HEREBY CERTIFY THAT I HAVE SURVEYED AND PLATTED THE LAND DESCRIBED IN THE DEDICATION ON THIS PLAT AS CAROL-ROSE ACRES; THAT THIS PLAT IS A CORRECT REPRESENTATION OF SAID SURVEY; THAT ALL DISTANCES ARE CORRECTLY SHOWN ON SAID PLAT; THAT ALL MONUMENTS HAVE BEEN CORRECTLY PLACED IN THE GROUND AS SHOWN; THAT THE OUTSIDE BOUNDARIES OF THE LAND ARE CORRECTLY DESIGNATED ON SAID PLAT; AND THAT THERE ARE NO WET LANDS OR PUBLIC HIGHWAYS TO BE DESIGNATED ON SAID PLAT OTHER THAN ARE SHOWN THEREON.

*N.C. Hoium*  
REGISTERED LAND SURVEYOR - MINN. REG. NO. 4427

STATE OF MINNESOTA) ss  
COUNTY OF ANOKA) ON THIS 11<sup>TH</sup> DAY OF SEPT. A.D. 1972, BEFORE ME, A NOTARY PUBLIC WITHIN AND FOR SAID COUNTY AND STATE, SURVEYOR'S CERTIFICATE SUBSCRIBED AND SWORN TO BEFORE ME, A NOTARY PUBLIC WITHIN AND FOR SAID COUNTY AND STATE.

MY COMMISSION EXPIRES 6-23-1977

*Gail E. Schuette*  
NOTARY PUBLIC, ANOKA COUNTY, MINNESOTA

ANNEXED PLAT OF CAROL-ROSE ACRES WAS APPROVED BY THE TOWN BOARD OF THE TOWNSHIP OF RAMSEY AT A REGULAR MEETING THEREOF HELD THIS 18<sup>TH</sup> DAY OF SEPT. A.D. 1972.

*Heck Murphy* CHAIRMAN  
*James M. Peterson* CLERK

ANNEXED PLAT OF CAROL-ROSE ACRES WAS APPROVED BY THE PLANNING COMMISSION OF THE TOWNSHIP OF RAMSEY AT A REGULAR MEETING THEREOF HELD THIS 11<sup>TH</sup> DAY OF SEPT. A.D. 1972.

*Ray R. Reimann* CHAIRMAN

RECOMMENDED FOR APPROVAL THIS 10<sup>TH</sup> DAY OF Oct. A.D. 1972.

*P.J. Lundheim*  
ANOKA COUNTY HIGHWAY ENGINEER

THIS PLAT WAS APPROVED AS TO FORM AND EXECUTION ON THIS 20<sup>TH</sup> DAY OF Nov. A.D. 1972.

*Robert Johnson*  
COUNTY ATTORNEY, ANOKA COUNTY, MINNESOTA

CHECKED AND APPROVED THIS 11<sup>TH</sup> DAY OF October A.D. 1972.

*Roland W. Anderson*  
ANOKA COUNTY SURVEYOR

THIS PLAT WAS APPROVED AND ACCEPTED BY THE BOARD OF COUNTY COMMISSIONERS OF THE COUNTY OF ANOKA, STATE OF MINNESOTA, AT A REGULAR MEETING THEREOF HELD THIS 10 DAY OF Oct. A.D. 1972.

*Walter R. ...* CHAIRMAN  
*Charles R. Lefebvre* COUNTY AUDITOR

**N.C. HOIUM & ASSOCIATES, INC.**  
Engineers—Surveyors

OFFICE OF REGISTER OF DEEDS  
STATE OF MINNESOTA, COUNTY OF ANOKA

I hereby certify that the within instrument was filed in this office for record on the 21<sup>st</sup> day of SEPT. A.D. 1972 at 12 o'clock P.M. and was duly recorded in book 10 of Plate 2 page 15.

*Ted J. ...*  
By *Margaret Russell*

"NO DELINQUENT TAXES AND TRANSFER ENTERED"

Nov. 8 1972

*Charles K. Lefebvre*  
Auditor, Anoka County

BY *Henry C. Johnson*  
Deputy