

# CAROLINE ACRES

## TOWNSHIP OF RAMSEY

### ANOKA COUNTY, MINNESOTA

COUNTY ROAD NO. 64

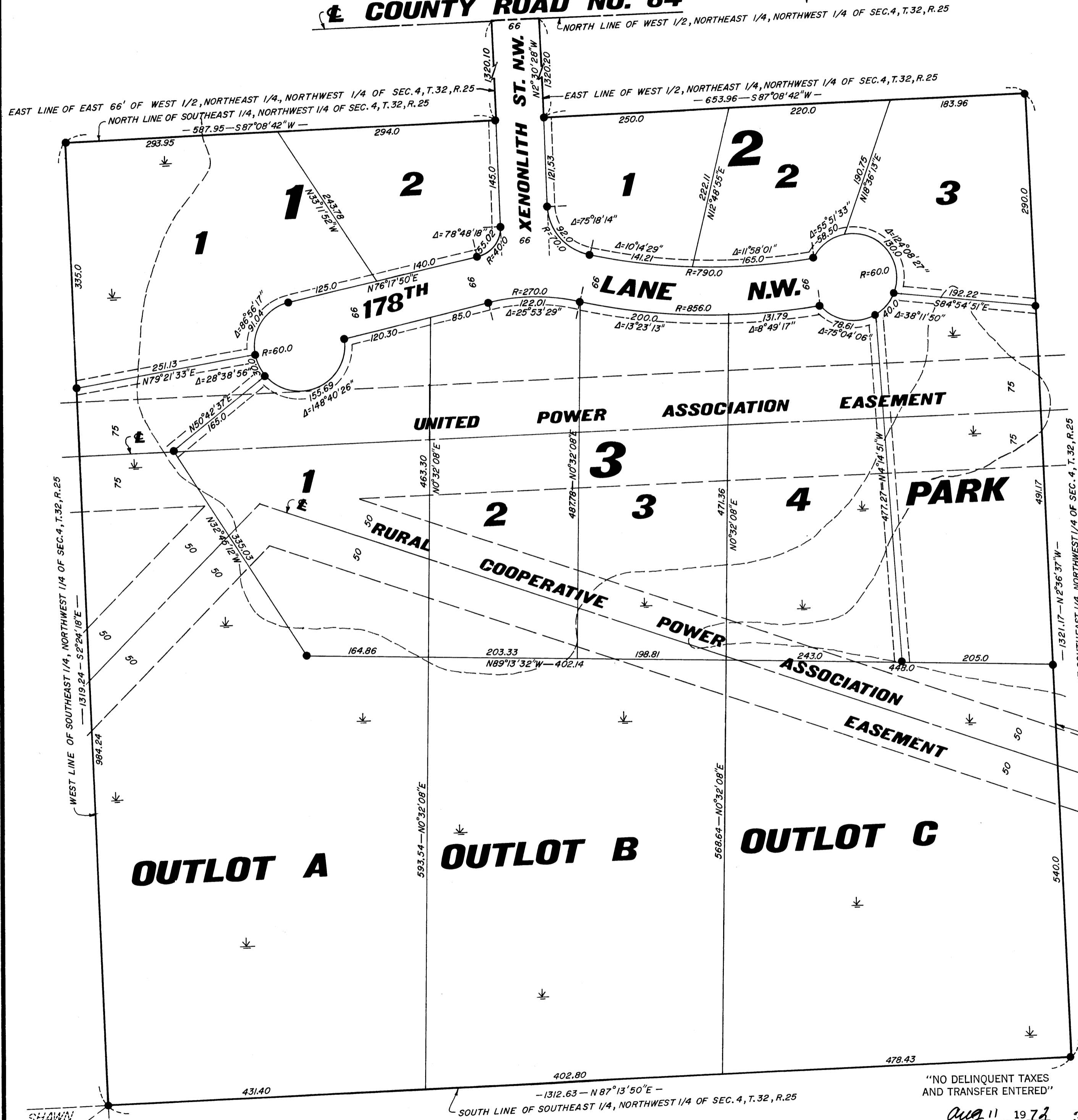
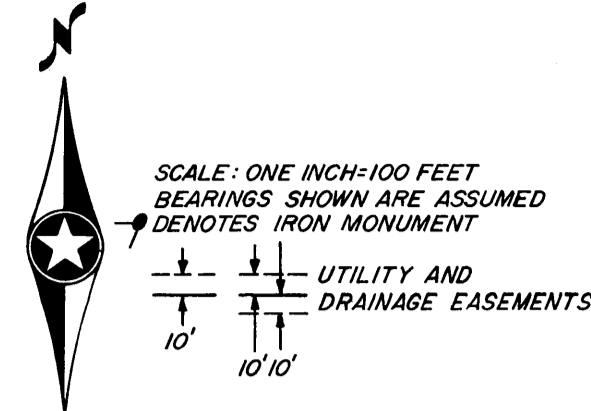

**N. C. HOIUM & ASSOCIATES, INC.**  
Engineers-Surveyors

KNOW ALL MEN BY THESE PRESENTS: THAT DALE J. DIETRICH AND ALICE J. DIETRICH, HIS WIFE, OWNERS AND PROPRIETORS, AND FIRST NATIONAL BANK IN ANOKA, A CORPORATION ORGANIZED UNDER THE LAWS OF THE UNITED STATES, MORTGAGEE, OF THE FOLLOWING DESCRIBED PROPERTY SITUATED IN THE COUNTY OF ANOKA AND STATE OF MINNESOTA TO-WIT: THE SOUTHEAST 1/4 OF THE NORTHWEST 1/4 AND THE EAST 66 FEET OF THE WEST 1/2 OF THE NORTHEAST 1/4 OF THE NORTHWEST 1/4, ALL IN SECTION 4, TOWNSHIP 32, RANGE 25.

HAVE CAUSED THE SAME TO BE SURVEYED AND PLATTED AS CAROLINE ACRES AND DO HEREBY DONATE AND DEDICATE TO THE PUBLIC FOR PUBLIC USE FOREVER THE LAND, ROAD, PARK AND STREET AS SHOWN ON THE PLAT. ALSO RESERVING THE EASEMENTS FOR UTILITY AND DRAINAGE PURPOSES AS SHOWN ON THE PLAT. ALSO SUBJECT TO EASEMENTS OF RECORD TO RURAL COOPERATIVE POWER ASSOCIATION. IN WITNESS WHEREOF SAID DALE J. DIETRICH AND ALICE J. DIETRICH, HIS WIFE, HAVE HEREUNTO SET THEIR HANDS AND SEALS ON THIS 16 DAY OF June A.D. 1972. POWER ASSOCIATION ALSO FIRST NATIONAL BANK IN ANOKA, HAS CAUSED THESE PRESENTS TO BE SIGNED BY ITS PROPER OFFICERS AND ITS CORPORATE SEAL TO BE AFFIXED ON THIS 16 DAY OF June A.D. 1972.

IN THE PRESENCE OF:

*[Signatures]* AND *[Signatures]*  
*[Signatures]* AND *[Signatures]*  
*[Signatures]* AND *[Signatures]*  
*[Signatures]* AND *[Signatures]*

SIGNED:

*[Signature]*  
DALE J. DIETRICH  
*[Signature]*  
ALICE J. DIETRICH  
FIRST NATIONAL BANK IN ANOKA  
BY *[Signature]* VICE-PRESIDENT  
BY *[Signature]* CASHIER

STATE OF MINNESOTA )  
COUNTY OF ANOKA ) ss  
ON THIS 16 DAY OF June A.D. 1972, BEFORE ME, A NOTARY PUBLIC WITHIN AND FOR SAID COUNTY AND STATE, PERSONALLY APPEARED DALE J. DIETRICH AND ALICE J. DIETRICH, HIS WIFE, TO ME PERSONALLY KNOWN TO BE THE PERSONS DESCRIBED IN AND WHO EXECUTED THE FOREGOING INSTRUMENT AND THEY AFFIRM AND ACKNOWLEDGE THE SAME AS THEIR OWN FREE ACT AND DEED.

MY COMMISSION EXPIRES BARBARA OGAARD  
Notary Public - Anoka County, Minn.  
My Commission Expires Nov. 16, 1977.

*[Signature]*  
NOTARY PUBLIC, ANOKA COUNTY, MINNESOTA

STATE OF MINNESOTA )  
COUNTY OF ANOKA ) ss  
ON THIS 16 DAY OF June A.D. 1972, BEFORE ME, A NOTARY PUBLIC WITHIN AND FOR SAID COUNTY AND STATE, PERSONALLY APPEARED ARVIN E. LENZ AND R. L. LARSEN, TO ME PERSONALLY KNOWN, WHO BEING BY ME DULY SWORN, DID SAY THAT THEY ARE THE VICE-PRESIDENT AND CASHIER, RESPECTIVELY, OF FIRST NATIONAL BANK IN ANOKA, THE CORPORATION NAMED IN THE FOREGOING INSTRUMENT; THAT THE SEAL AFFIXED TO SAID INSTRUMENT IS THE CORPORATE SEAL OF SAID CORPORATION; AND THAT SAID INSTRUMENT WAS SIGNED AND SEALED IN BEHALF OF SAID CORPORATION BY AUTHORITY OF ITS BOARD OF DIRECTORS, AND SAID ARVIN E. LENZ AND R. L. LARSEN, ACKNOWLEDGE SAID INSTRUMENT TO BE THE FREE ACT AND DEED OF SAID CORPORATION.

MY COMMISSION EXPIRES BARBARA OGAARD  
Notary Public - Anoka County, Minn.  
My Commission Expires Nov. 16, 1977.

*[Signature]*  
NOTARY PUBLIC, ANOKA COUNTY, MINNESOTA

I HEREBY CERTIFY THAT I HAVE SURVEYED AND PLATTED THE LAND DESCRIBED IN THE DEDICATION ON THIS PLAT AS CAROLINE ACRES; THAT THIS PLAT IS A CORRECT REPRESENTATION OF SAID SURVEY; THAT ALL DISTANCES ARE CORRECTLY SHOWN ON SAID PLAT; THAT ALL MONUMENTS HAVE BEEN CORRECTLY PLACED IN THE GROUND AS SHOWN; THAT THE OUTSIDE BOUNDARIES OF THE LAND ARE CORRECTLY DESIGNATED ON SAID PLAT; AND THAT THERE ARE NO HIGHWAYS OR WET LANDS OTHER THAN SHOWN THEREON.

*[Signature]*  
REGISTERED LAND SURVEYOR - MINN. REG. NO. 4427

STATE OF MINNESOTA )  
COUNTY OF ANOKA ) ss  
SURVEYOR'S CERTIFICATE SUBSCRIBED AND SWORN TO BEFORE ME, A NOTARY PUBLIC WITHIN AND FOR SAID COUNTY AND STATE ON THIS 6<sup>th</sup> DAY OF MARCH A.D. 1972.

MY COMMISSION EXPIRES 6-23-1977  
GAIL E. SCHUETTE  
Notary Public, Anoka County, Minn.  
My Commission Expires June 23, 1977.

*[Signature]*  
NOTARY PUBLIC, ANOKA COUNTY, MINNESOTA

ANNEXED PLAT OF CAROLINE ACRES WAS APPROVED BY THE TOWN BOARD OF THE TOWNSHIP OF RAMSEY AT A REGULAR MEETING THEREOF HELD THIS 20<sup>th</sup> DAY OF MARCH A.D. 1972.

*[Signature]* CHAIRMAN  
*[Signature]* CLERK

ANNEXED PLAT OF CAROLINE ACRES WAS APPROVED BY THE PLANNING COMMISSION OF THE TOWNSHIP OF RAMSEY AT A REGULAR MEETING THEREOF HELD THIS 6<sup>th</sup> DAY OF MARCH A.D. 1972.

*[Signature]* CHAIRMAN

RECOMMENDED FOR APPROVAL THIS 20<sup>th</sup> DAY OF June A.D. 1972.

*[Signature]*  
ANOKA COUNTY HIGHWAY ENGINEER

THIS PLAT WAS APPROVED AS TO FORM AND EXECUTION ON THIS 9<sup>th</sup> DAY OF August A.D. 1972.

*[Signature]*  
COUNTY ATTORNEY, ANOKA COUNTY, MINNESOTA

CHECKED AND APPROVED THIS 20<sup>th</sup> DAY OF June A.D. 1972.

*[Signature]*  
ANOKA COUNTY SURVEYOR

"NO DELINQUENT TAXES AND TRANSFER ENTERED"

Aug 11 1972 373397  
*[Signature]*  
Auditor, Anoka County

BY *[Signature]*  
Deputy

THIS PLAT WAS APPROVED AND ACCEPTED BY THE BOARD OF COUNTY COMMISSIONERS OF THE COUNTY OF ANOKA, STATE OF MINNESOTA, AT A REGULAR MEETING THEREOF HELD THIS 20<sup>th</sup> DAY OF June A.D. 1972.

OFFICE OF REGISTER OF DEEDS  
STATE OF MINNESOTA, COUNTY OF ANOKA ) ss

I hereby certify that the within instrument was filed in this office for record on the day of AUG. 11 1972 A.D. 1972 at 2 o'clock P.M. and was duly recorded in book 9 of plat 107.

*[Signature]* CHAIRMAN  
*[Signature]* COUNTY AUDITOR  
by *[Signature]* Deputy

*[Signature]*  
Inspector of Deeds by Margaret Russell, Deputy