

OFFICIAL PLAT

THE PONDS OF RAMSEY

CITY OF RAMSEY
COUNTY OF ANOKA
SEC.25 & 26-T32N-R25W
Book 63 Page 31

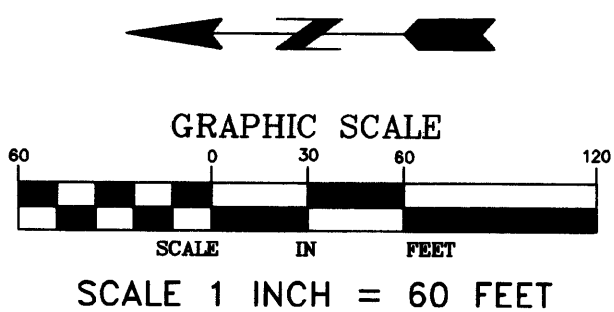
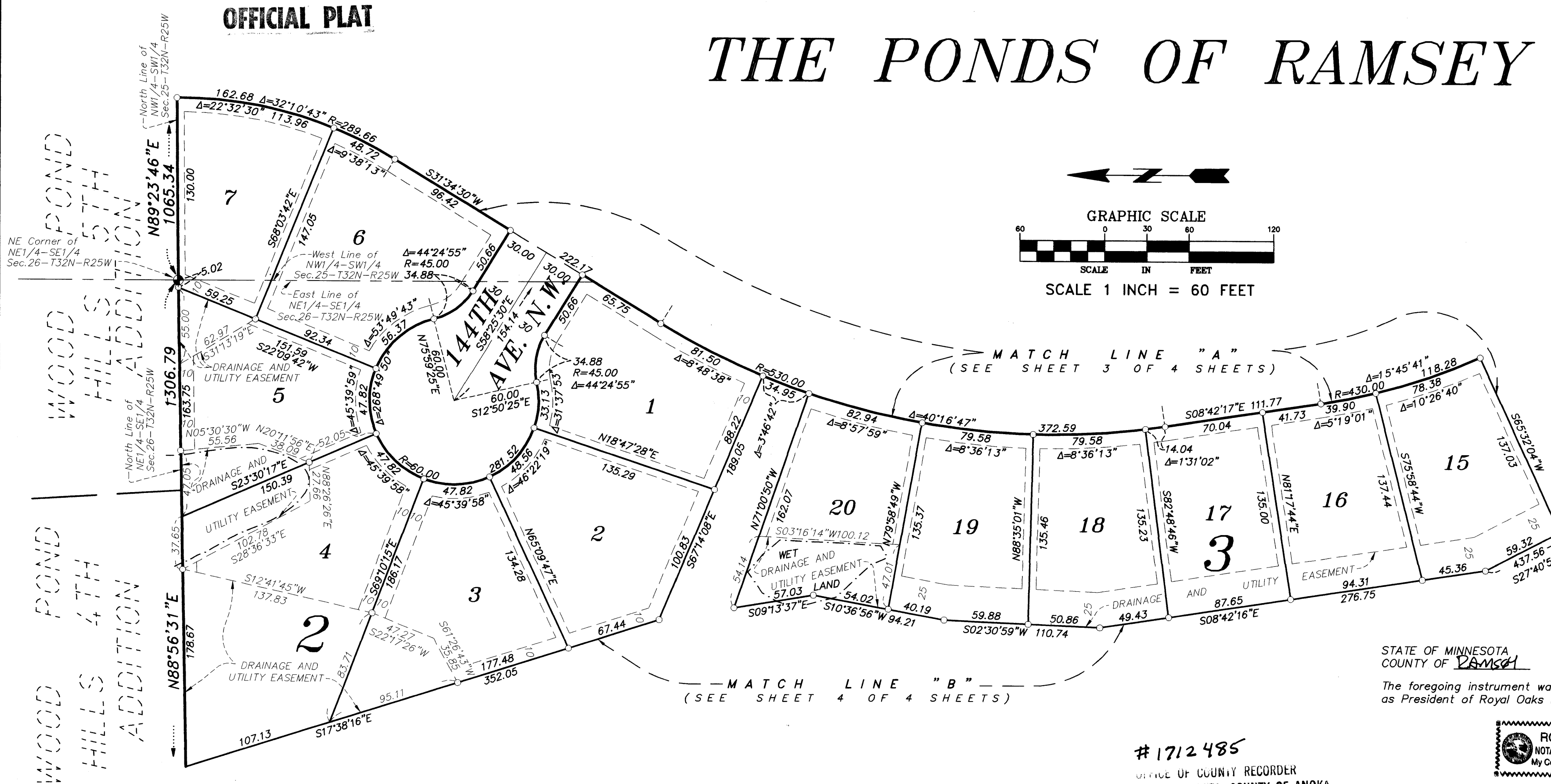

- NOTES:
- DENOTES 1/2 INCH BY 14 INCH IRON PIPE MONUMENT SET AND MARKED WITH A PLASTIC CAP INSCRIBED "RLS 10947"
- DENOTES MONUMENT FOUND
- DENOTES ANOKA COUNTY MONUMENT
- DENOTES RIGHT OF ACCESS DEDICATED TO THE COUNTY OF ANOKA.

DRAINAGE AND UTILITY EASEMENTS ARE SHOWN THUS:
BEING 5 FEET IN WIDTH AND ADJOINING LOT LINES, AND 10 FEET IN WIDTH AND ADJOINING RIGHT-OF-WAY LINES UNLESS OTHERWISE SHOWN ON THE PLAT.

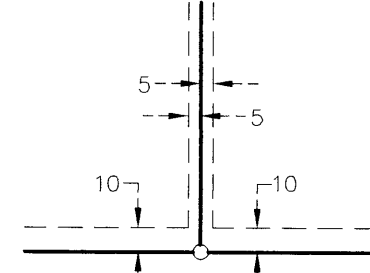

BENCHMARK:
- TOP OF CAST IRON MONUMENT AT NORTHEAST CORNER OF NORTHEAST QUARTER OF NORTHEAST QUARTER OF SEC.26-T32N-R25W ELEVATION = 871.33 (NGVD29)

MIDWEST Land Surveyors & Civil Engineers, Inc.

KNOW ALL PERSONS BY THESE PRESENTS: That Royal Oaks Realty Inc. a Minnesota Corporation and Dale T. Dockendorf and Kathleen J. Dockendorf, husband and wife, fee owners and Builders Development & Finance, Inc., a Minnesota Corporation, mortgagee of the following described property situated in the County of Anoka, State of Minnesota to wit:

That part of the Northeast 1/4 of the Southwest 1/4 of Section 25, Township 32, Range 25, lying Southwesterly of the Southwesterly right of way line of County State Aid Highway No. 5 and lying westerly of the Westerly right of way line of Dysprosium Street, except that part described as follows:

Commencing at the Southwest corner of said 1/4 1/4, thence North 89 degrees, 51 minutes, 23 seconds East (assumed bearing) along the Southerly line of said 1/4 1/4 469.93 feet, thence Northerly 208.74 feet along a non-tangential curve concave to the West having a radius of 260 feet and a central angle of 46 degrees and the chord of said curve bears North 5 degrees, 12 minutes, 55 seconds East and is 203.18 feet in length, thence North 17 degrees, 47 minutes 5 seconds West tangent to said curve 50 feet, thence Northerly 151.47 feet along a tangential curve concave to the East, having a radius of 340 feet and a central angle of 25 degrees, 31 minutes, 31 seconds to the point of beginning of said tract to be described. Thence Northerly 178.48 feet along a continuation of said curve having a radius of 340 feet and a central angle of 30 degrees, 4 minutes, 38 seconds to its intersection with the Southerly right of way line of County State Aid Highway No. 5, thence Northwesterly 52.63 feet along said right of way line on a non-tangential spiral offset curve concave to the Northeast having a chord which bears North 46 degrees, 28 minutes, 58 seconds West and is 52.63 feet in length, thence North 46 degrees, 24 minutes 34 seconds West along said right of way line and tangent to said curve 147.60 feet, thence South 43 degrees, 35 minutes 26 seconds West 200 feet, thence South 46 degrees, 24 minutes, 34 seconds East 214.29 feet, thence South 82 degrees, 15 minutes 34 second East 60 feet to the point of beginning.

AND
The Northwest 1/4 of the Southwest 1/4 of Section 25, Township 32, Range 25, except that portion taken for County State Aid Highway No. 5, Anoka County, Minnesota.

AND
The Northeast 1/4 of the Southeast 1/4 of Section 26, Township 32, Range 25, Anoka County, Minnesota.
Have caused the same to be surveyed and platted as THE PONDS OF RAMSEY and do hereby donate and dedicate to the public for public use forever the avenues, courts, street, way, parks and easements for drainage and utility purposes and dedicate to Anoka County the right of access onto County State Aid Highway No. 5 as shown on the plat.

In witness whereof said Royal Oaks Realty, Inc., a Minnesota Corporation has caused these presents to be signed by its President this 6th day of September 2002

ROYAL OAKS REALTY, INC.
Marcel Eibensteiner, President

In witness whereof said Dale T. Dockendorf and Kathleen J. Dockendorf have hereunto set their hands this 6th day of September, 2002

Dale T. Dockendorf, Kathleen J. Dockendorf

In witness whereof said Builders Development & Finance, Inc., a Minnesota Corporation, has caused these presents to be signed by its President this 6th day of September, 2002

BUILDERS DEVELOPMENT AND FINANCE, INC
Bill Keenan, President

#1712485
OFFICE OF COUNTY RECORDER
STATE OF MINNESOTA, COUNTY OF ANOKA
I hereby certify that the within instrument was filed in this office for record on the 24 SEP AD, 2002 at 9:45 o'clock A.M., and was duly recorded in book 63 page 31
Manson J. Devina
County Recorder

STATE OF MINNESOTA
COUNTY OF Ramsey
The foregoing instrument was acknowledged before me this 6th day of September, 2002, by Marcel Eibensteiner, as President of Royal Oaks Realty, Inc., a Minnesota Corporation, on behalf of the Corporation.

RONALD J. RIACH
NOTARY PUBLIC - MINNESOTA
My Comm. Expires Jan. 31, 2005

Notary Public, Ramsey County, Minnesota
My commission expires

STATE OF MINNESOTA
COUNTY OF Ramsey
The foregoing instrument was acknowledged before me this 6th day of September, 2002, by Dale T. Dockendorf and Kathleen J. Dockendorf, husband and wife.

RONALD J. RIACH
NOTARY PUBLIC - MINNESOTA
My Comm. Expires Jan. 31, 2005

Notary Public, Ramsey County, Minnesota
My commission expires

STATE OF MINNESOTA
COUNTY OF Ramsey
The foregoing instrument was acknowledged before me this 6th day of September, 2002, by Bill Keenan, as President of Builders Development & Finance, Inc., a Minnesota Corporation, on behalf of the corporation.

Notary Public, Ramsey County, Minnesota
My commission expires Jan. 31, 2002

I hereby certify that I have surveyed and platted the land described on this plat as THE PONDS OF RAMSEY; that this plat is a true and correct representation of said survey; that all distances are correctly shown on the plat in feet and hundredths of a foot; that all monuments have been correctly placed in the ground as shown on said plat or will be placed as required by the local government unit as designated on said plat; that the outside boundary lines are correctly designated on the plat and that there are no wetlands as defined in Minnesota Statutes 505.02, Subd. 1 or public highways to be designated on said plat other than as shown.

Rodney H. Halvorson, Land Surveyor
Minnesota License No. 10947

STATE OF MINNESOTA
COUNTY OF Anoka
The foregoing instrument was acknowledged before me this 3rd day of September, 2002, by Rodney H. Halvorson, Land Surveyor.

DIANE S. HALVORSON
NOTARY PUBLIC - MINNESOTA
My Commission Expires Jan. 31, 2005

Notary Public, Anoka County, Minnesota
My commission expires 31 Jan 2005

The foregoing plat of THE PONDS OF RAMSEY was approved and accepted by the City Council of Ramsey, Minnesota at a regular meeting thereof held this 14th day of May, 2002. If applicable, the written comments and recommendations of the Commissioner of Transportation and the County Highway Engineer have been received by the City or the prescribed 30 day period has elapsed without receipt of such comments and recommendations, as provided by Minnesota Statutes, Section 505.03, Subd. 2.

CITY COUNCIL OF RAMSEY, MINNESOTA
By Mayor
By City Manager

Checked and approved this 21st day of September, 2002
Anoka County Surveyor

I HEREBY CERTIFY THAT THE CURRENT AND DELINQUENT TAXES ON THE LANDS DESCRIBED WITHIN ARE PAID AND THE TRANSFER IS ENTERED
MAUREN J. DEVINE
PROPERTY TAX ADMINISTRATOR



MIDWEST
Land Surveyors & Civil Engineers, Inc.

OFFICIAL PLAT

THE PONDS OF RAMSEY

CITY OF RAMSEY
COUNTY OF ANOKA
SEC.25&26-T32N-R25W
Book 63 PAGE 31

NOTES:

- DENOTES 1/2 INCH BY 14 INCH IRON PIPE MONUMENT SET AND MARKED WITH A PLASTIC CAP INSCRIBED "RLS 10947"
 - DENOTES MONUMENT FOUND
 - ▲ DENOTES ANOKA COUNTY MONUMENT
 - △ DENOTES RIGHT OF ACCESS DEDICATED TO THE COUNTY OF ANOKA.
- FOR THE PURPOSES OF THIS PLAT THE NORTH LINE OF NW1/4-SW1/4 OF SEC.25-T32N-R25W IS ASSUMED TO HAVE A BEARING OF N89°23'46"E.

BENCHMARK:

- TOP OF CAST IRON MONUMENT AT NORTHEAST CORNER OF NORTHEAST QUARTER OF SOUTHEAST QUARTER OF SEC.26-T32N-R25W ELEVATION = 871.33 (NGVD29)

DRAINAGE AND UTILITY EASEMENTS ARE SHOWN THUS:
BEING 5 FEET IN WIDTH AND ADJOINING LOT LINES, AND 10 FEET IN WIDTH AND ADJOINING RIGHT-OF-WAY LINES UNLESS OTHERWISE SHOWN ON THE PLAT.

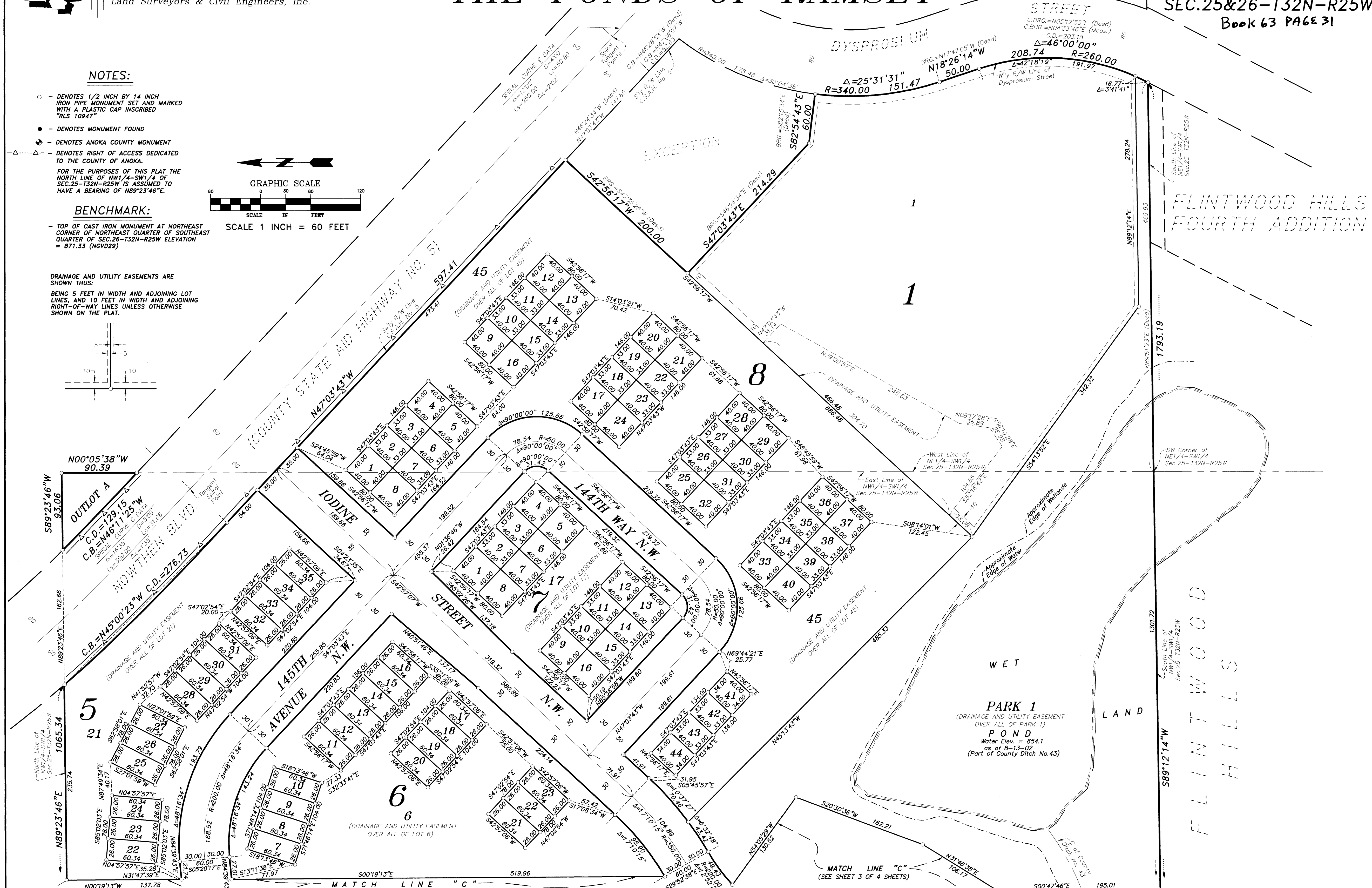
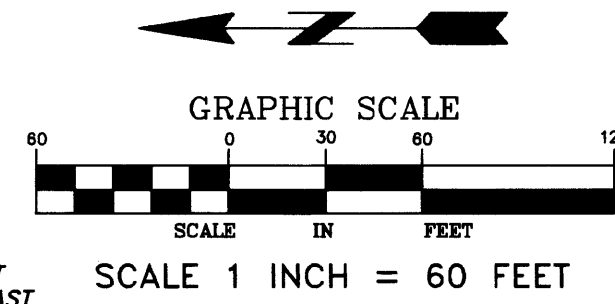
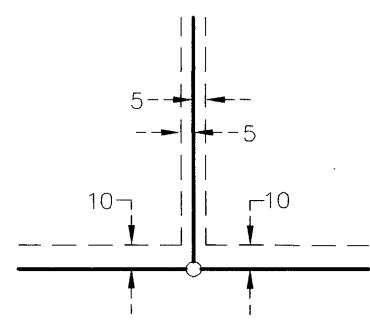

MATCH LINE "C"
(SEE SHEET 3 OF 4 SHEETS)

MATCH LINE "C"
(SEE SHEET 3 OF 4 SHEETS)

THE PONDS OF RAMSEY

CITY OF RAMSEY
COUNTY OF ANOKA
SEC.25 & 26-T32N-R25W
Book 63 PAGE 31

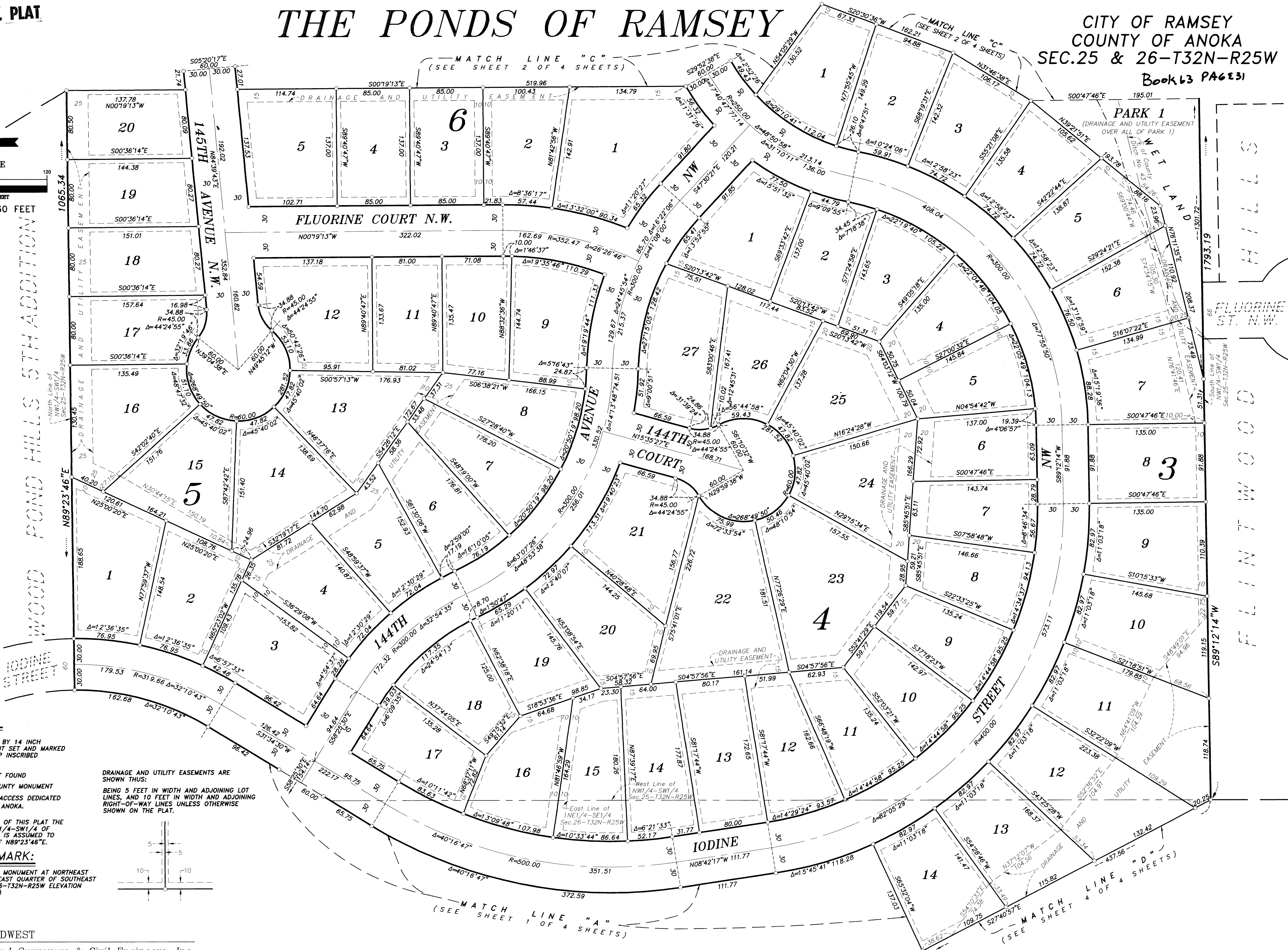
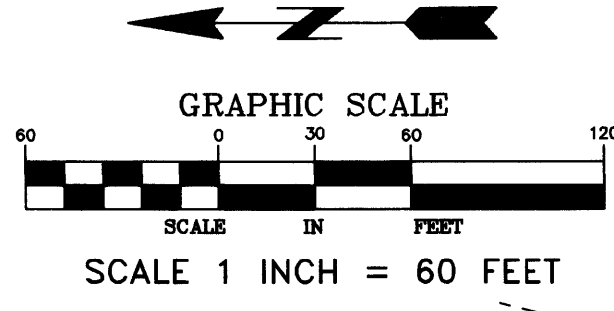

NOTES:

- DENOTES 1/2 INCH BY 14 INCH IRON PIPE MONUMENT SET AND MARKED WITH A PLASTIC CAP INSCRIBED "RLS 10947"
- DENOTES MONUMENT FOUND
- ◆ DENOTES ANOKA COUNTY MONUMENT
- △ DENOTES RIGHT OF ACCESS DEDICATED TO THE COUNTY OF ANOKA.

DRAINAGE AND UTILITY EASEMENTS ARE SHOWN THUS:
BEING 5 FEET IN WIDTH AND ADJOINING LOT LINES, AND 10 FEET IN WIDTH AND ADJOINING RIGHT-OF-WAY LINES UNLESS OTHERWISE SHOWN ON THE PLAT.

FOR THE PURPOSES OF THIS PLAT THE NORTH LINE OF NW1/4-SW1/4 OF SEC.25-T32N-R25W IS ASSUMED TO HAVE A BEARING OF N89°23'46"E.

BENCHMARK:

TOP OF CAST IRON MONUMENT AT NORTHEAST CORNER OF NORTHEAST QUARTER OF SOUTHWEST QUARTER OF SEC.26-T32N-R25W ELEVATION = 871.33 (NGVD29)

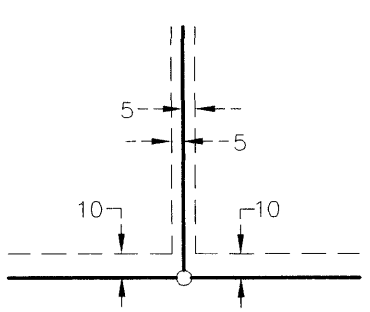

MIDWEST
Land Surveyors & Civil Engineers, Inc.

THE PONDS OF RAMSEY

CITY OF RAMSEY
COUNTY OF ANOKA
SEC.25 & 26-T32N-R25W
BOOK 63 PAGE 31

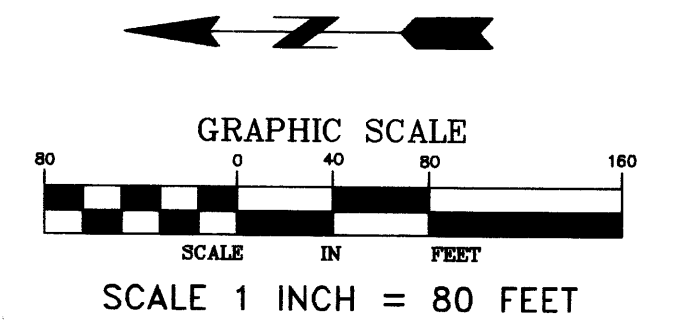
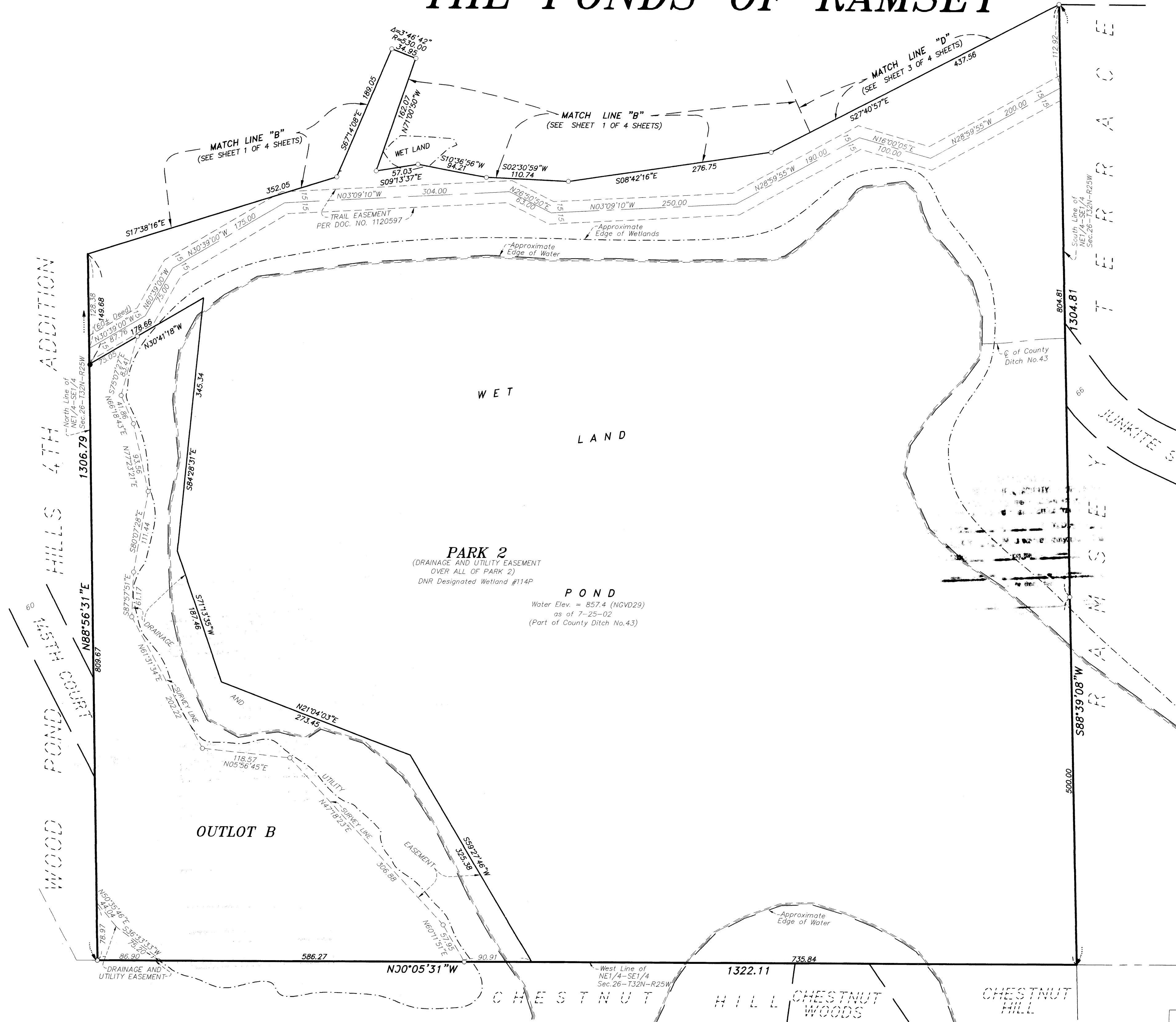

NOTES:

- - DENOTES 1/2 INCH BY 14 INCH IRON PIPE MONUMENT SET AND MARKED WITH A PLASTIC CAP INSCRIBED "RLS 10947"
- - DENOTES MONUMENT FOUND
- ⊕ - DENOTES ANOKA COUNTY MONUMENT
- △-△-△ - DENOTES RIGHT OF ACCESS DEDICATED TO THE COUNTY OF ANOKA.

FOR THE PURPOSES OF THIS PLAT THE NORTH LINE OF NW1/4-SW1/4 OF SEC.25-T32N-R25W IS ASSUMED TO HAVE A BEARING OF N89°23'46"E.

BENCHMARK:

- TOP OF CAST IRON MONUMENT AT NORTHEAST CORNER OF NORTHEAST QUARTER OF SOUTHEAST QUARTER OF SEC.26-T32N-R25W ELEVATION = 871.33 (NGVD29)

DRAINAGE AND UTILITY EASEMENTS ARE SHOWN THUS:
BEING 5 FEET IN WIDTH AND ADJOINING LOT LINES, AND 10 FEET IN WIDTH AND ADJOINING RIGHT-OF-WAY LINES UNLESS OTHERWISE SHOWN ON THE PLAT.

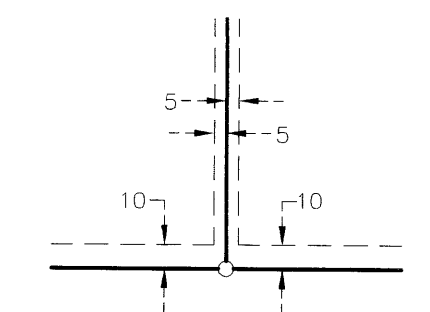

MIDWEST
Land Surveyors & Civil Engineers, Inc.

1712485

THIS DOCUMENT NUMBER REPRESENTS A PLAT

ALL PLATS ARE MAINTAINED ON A SEPARATE MICROFICHE IN A SEPARATE SECTION RESERVED FOR PLATS. FULL SIZE COPIES OF PLATS ARE STILL AVAILABLE FOR VIEWING.

MUNICIPALITY: Ramsey CERTIFIED BY: Ac ON 9/24/02

MAP # 2739 PLAT BOOK: 63 OF Abst PAGE 31

DOC. DATE: 9-6-02 NO. OF PAGES: 4 TRACT BOOK: _____ PAGE _____

PLAT SHORT NAME: THE Ponds of Ramsey

LONG NAME: THE Ponds of Ramsey

A/T	PARENT PINS	KEY	RES?	GRANTORS (Fees, C/Ps, Mortgagees)	Marital Status
A	25-32-25-31-0009	1308819	N	Royal Oaks Realty Inc	(fee)
A	32-0001	734147	N	Dockendorf Dale T.	(H/W)
A	26-32-25-41-0001	734 496	N	+ Kathleen J. Builders Development + + Finance Inc (mortgagee)	(fee)

FILED BY: Mareel Cibensteiner PHONE 651-483-5518
 TAXPAYER NAME: Royal Oaks
 ADDRESS: 1006 Cty Rd E W Ste 150
 CITY: Shoreview STATE: Mn ZIP: 55126

NEW PARCELS

LOT	BLOCK	LOT	BLOCK	LOT	BLOCK
1	1	1-35	5	A, B	0/L
1-7	2	1-23	6	PARK	1+2-del.
1-20	3	1-17	7		
1-27	4	1-45	8		

179

DELT & CURRENT TAXES ARE PAID: INITIALS: [Signature] DATE: 9/24/02 DIV. NO.: _____ DIV. FEE: \$5410

ABSTRACT

Receipt #	112554/552450	<input type="checkbox"/> Incorrect/No Reference #
Date/Time	9/24/02 9:45	<input type="checkbox"/> Non-standard Document
Document Order	1 of 1	<input type="checkbox"/> Certified Copy/
PINs	82	
Recordability	82	
Filing Fees	\$ 114.50	
Copy/Additional Pg Fees	\$	<input type="checkbox"/> Tax Lien/Release
Well Cert Fees	\$	<input type="checkbox"/> Transfer
<input type="checkbox"/> Incomplete Form		<input type="checkbox"/> Division
<input type="checkbox"/> Missing Attachment		<input type="checkbox"/> Status
<input type="checkbox"/> No Legal Description		<input checked="" type="checkbox"/> New legal Description
<input type="checkbox"/> Non-existent Legal Description		<input type="checkbox"/> GAC
<input type="checkbox"/> Part(s) Illegible		<input type="checkbox"/> Deferred Specials
		<input type="checkbox"/> No Change

DOCUMENT NO. 1712485.0 **ABSTRACT**
ANOKA COUNTY MINNESOTA

I HEREBY CERTIFY THAT THE WITHIN INSTRUMENT WAS FILED IN THIS OFFICE
FOR RECORD ON **SEP 24 2002**
AT **9:45 AM** AND WAS DULY RECORDED.
FEES AND TAXES IN THE AMOUNT OF **\$5524.50 PAID.**

RECEIPT NO. **2002112554**
MAUREEN J. DEVINE
ANOKA COUNTY PROPERTY TAX ADMINISTRATOR/RECORDER/REGISTRAR OF TITLES
BY **SLZ**
DEPUTY PROPERTY TAX ADMINISTRATOR/RECORDER/REGISTRAR OF TITLES

1805908.D

DECLARATION FOR NEW CIC

THIS PAGE IS NOT PART OF THE ORIGINAL DOCUMENT PRESENTED FOR RECORDING

Added by Anoka County Recorder for posting only.

MUNICIPALITY Ramsey CHECKED BY 2 ON 5/30/02

MAP # 2891 PLAT BOOK TYPE _____

DOC DATE 5/30/02 NO OF PAGES _____ TRACT BOOK _____ PAGE _____

CIC SHORT NAME CIC NO 140, The Ponds of Ramsey

LONG NAME BY DECLARATION

A/T	PARENT PINS	THRU
A	25.32.25.32.0061	0075
	— 32.0081	0098
	— 32.0099	0115
	— 31.0013	0019
	— 32.0116	
	— 31.0020	0035
	— 32.0117	
	— 31.0036	0040
	— 32.0118	0132

A/T	PARENT PINS	THRU

DATE. _____

DIV NO _____

1805908

COMMON INTEREST COMMUNITY NUMBER 140
THE PONDS OF RAMSEY TOWNHOMES

PLANNED COMMUNITY
DECLARATION

This Declaration is made in the County of Anoka, State of Minnesota, on this 30 day of MAY, 2003, by Shade Tree Construction, Inc , a Minnesota corporation, (the "Declarant"), pursuant to the provisions of Minnesota Statutes Chapter 515B, known as the Minnesota Common Interest Ownership Act (the "Act"), for the purpose of creating Common Interest Community Number 140

WHEREAS, Declarant is the owner in fee, contract purchaser, or developer of certain real property located in Anoka County, Minnesota, legally described on Exhibit A attached hereto and Declarant desires to submit said real property and all improvements thereon (collectively, the "Property") to the Act, and

WHEREAS, Declarant desires to establish on the Property a plan for a permanent residential Townhome community to be owned, occupied and operated for the use, health, safety, and welfare of its resident Owners and Occupants, and for the purpose of preserving the value, the structural quality, and the original architectural and aesthetic character of the Property, and

THEREFORE, Declarant makes the Declaration and submits the Property to the Act to establish as a Common Interest Community ("CIC"), Common Interest Community Number __, The Ponds of Ramsey Townhomes, Anoka County, Minnesota, as a planned community, consisting of the Units referred to in Section 2, declaring that this Declaration shall constitute covenants to run with the Property, and that the Property shall be owned, used, occupied, and conveyed subject to the covenants, restrictions, easements, charges and liens set forth herein, all of which shall be binding upon all Persons owning or acquiring any right, title or interest therein, and their heirs, personal representatives, successors and assigns

ARTICLE I
DEFINITIONS

The following words when used in the Governing Documents shall have the following meanings (unless the context indicates otherwise)

1.1 **“Association”** shall mean The Ponds of Ramsey Townhomes Association, a nonprofit corporation which has been created pursuant to Chapter 317A of the laws of the State of Minnesota and Minnesota Statutes Section 515B.3-101, whose members consist of all Owners as defined herein

1.2 **“Board”** shall mean the Board of Directors of the Association as provided for in the By-Laws

1.3 **“By-Laws”** shall mean the By-Laws governing the operation of the Association, as amended from time to time.

1.4 **“Common Elements”** shall mean all parts of the Property except the Units, including all improvements thereon, owned by the Association for the common benefit of the Owners and Occupants

1.5 **“Common Expense”** shall mean and include all expenditures made or liabilities incurred by or on behalf of the Association and incident to its operation, including, without limitation, allocations to reserves and those items specifically identified as Common Expenses in this Declaration or the By-Laws

1.6 **“Declaration”** means any instrument, however, denominated, including any amendment to the instrument, that creates a common interest community

1.7 **“Dispose” or “Disposition”** means a voluntary transfer to a purchaser of any legal or equitable interest in the common interest community, but the term does not include the transfer or release of a security interest

1.8 **“Dwelling”** shall mean a part of a building consisting of one or more floors, designed and intended for occupancy as a single-family residence. The Dwelling includes any garage attached thereto or otherwise within the boundaries of the Unit in which the Dwelling is located

1.9 **“Eligible Mortgagee”** shall mean any Person owning a mortgage on any Unit, which mortgage is first in priority upon foreclosure to all other mortgages that encumber such Unit, and which has requested the Association, in writing, to notify it regarding any proposed action which requires approval by a specified percentage of Eligible Mortgagees

1.10 **“Governing Documents”** shall mean this Declaration, and the Articles of Incorporation and By-Laws of the Association, as amended from time to time, all of which shall govern the use and operation of the Property

1.11 “Limited Common Elements” shall mean those parts of the Common Elements reserved for the exclusive use of the Owners and Occupants of the Units to which they are allocated, and the rights to the use and enjoyment thereof are automatically conveyed with the conveyance of such Units

1.12 “Member” shall mean all persons who are members of the Association by virtue of being Owners as defined in this Declaration. The words “Owner” and “Member” may be used interchangeably in the Governing Documents

1.13 “Occupant” shall mean any person or persons, other than an Owner, in possession of or residing in a Unit

1.14 “Owner” shall mean a Person who owns a Unit, but excluding contract for deed vendors, mortgagees and other secured parties within the meaning of Section 515B.1-103(29) of the Act. The term “Owner” includes, without limitation, contract for deed vendees and holders of a life estate

1.15 “Party Wall” shall mean the shared wall between two Dwellings

1.16 “Person” shall mean a natural individual, corporation, limited liability company, partnership, trustee, or other legal entity capable of holding title to real property.

1.17 “Plat” shall mean the recorded plat or plats depicting the Property pursuant to the requirements of Section 515B 2-110(d) of the Act, and satisfying the requirements of Minnesota Statutes Chapter 505, 508 or 508A, as applicable, including any amended or supplemental Plat recorded from time to time in accordance with the Act

1.18 “Property” shall mean all of the real property submitted to this Declaration, including the Dwellings and all other structures and improvements located thereon now or in the future. Improvements located thereon include all utilities such as storm and sanitary sewers, water pipes and mains and the like. The Property as of the date of this Declaration is legally described in Exhibit A attached hereto.

1.19 “Rules and Regulations” shall mean the Rules and Regulations of the Association as approved from time to time pursuant to Section 5.6.

1.20 “Special Declarant Rights” means rights reserved in this Declaration for the benefit of a Declarant to: (i) complete improvements indicated on the CIC plat, (ii) subdivide units or convert units into common elements, limited common elements and/or units; (iii) maintain sales offices, management offices, signs advertising the common interest community, and models, (iv) use easements through the common elements for the purpose of making improvements within the common interest community or any additional real estate, (v) create a master association and provide for the exercise of authority by the master association over the common interest community or its unit owners, (vi) merge or consolidate a common interest community with another common interest community of the same form of ownership, or (vii) appoint or remove any officer or director of the Association, or the master association where applicable, during any period of Declarant control.

1.21 **“Townhome”** shall mean a single residential unit, subject to a party wall or walls, located on a single residential lot.

1.22 **“Unit”** shall mean any platted lot subject to this Declaration upon which a Dwelling is located or intended to be located, including all improvements thereon, but excluding the Common Elements

Any terms used in the Governing Documents, and defined in the Act and not in this Section, shall have the meaning set forth in the Act

ARTICLE II **DESCRIPTION OF UNITS AND APPURTENANCES**

2.1 **Units** There are ninety one (91) Units, all of which are restricted exclusively to residential use as Townhomes. No additional Units may be created by the subdivision or conversion of Units pursuant to Section 515B 2-112 of the Act except by the Declarant as provided in this Declaration. The Unit identifiers and locations of the Units are as shown on the Plat, which is incorporated herein by reference, and a schedule of Units is set forth on Exhibit A. The Unit identifier for a Unit shall be its lot and block number and the subdivision name

2.2 **Unit Boundaries** The unit boundaries are shown on the Plat

2.3 **Use and Enjoyment Easements** Each Unit shall be the beneficiary of appurtenant easements for use and enjoyment on and across the Common Elements, and for use and enjoyment of any Limited Common Elements allocated to the Unit, subject to any restrictions authorized by this Declaration

2.4 **Utility and Maintenance Easements** Each Unit shall be subject to and shall be the beneficiary of appurtenant easements for all services and utilities servicing the Units and the Common Elements, and for maintenance, repair, replacement and reconstruction as described in Section 13

2.5 **Encroachment Easements.** Each Unit shall be subject to and shall be the beneficiary of the appurtenant easements for encroachments as described in Section 13.

2.6 **Declarant’s Easements** Declarant shall have and be the beneficiary of easements for construction and sales activities as described in Section 15 3

2.7 **Recorded Easements** The Property shall be subject to such other easements as may be recorded against it or otherwise shown on the Plat

2.8 **Easements are Appurtenant** All easements and similar rights burdening or benefiting a Unit or any other part of the Property shall be appurtenant thereto, and shall be permanent, subject only to termination in accordance with the Act or the terms of the easement. Any recorded easement benefiting or burdening the Property shall be construed in a manner consistent with, and not in conflict with, the easements created by this Declaration.

2.9 Impairment Prohibited No person shall materially restrict or impair any easement benefiting or burdening the Property, subject to this Declaration and the right of the Association to impose reasonable Rules and Regulations governing the use of the Property

2.10 No Master Association The common interest community described in this Declaration is not subject to a master association.

ARTICLE III **COMMON ELEMENTS AND LIMITED COMMON ELEMENTS**

3.1 Common Elements The Common Elements and their characteristics are as follows:

a. All of the Property not included within the Units constitutes Common Elements. The Common Elements include those parts of the Property described in Exhibit B or designated as Common Elements on the Plat or in the Act. The Common Elements are owned by the Association for the benefit of the Owners and Occupants

b. The Common Elements shall be subject to appurtenant easements for services, public and private utilities, access, use and enjoyment in favor of each Unit and its Owners and Occupants; subject to (i) the right of Owners and Occupants in Limited Common Elements appurtenant to their Units, and (ii) the right of the Association to establish reasonable Rules and Regulations governing the use of the Property

c. Subject to Sections 5, 6 and 9, all maintenance, repair, replacement, management, and operation of the Common Elements shall be the responsibility of the Association

d. Common Expenses for the maintenance, repair, replacement, management and operation of the Common Elements shall be assessed and collected from the Owners in accordance with Section 6.

3.2 Limited Common Elements The Limited Common Elements are those parts of the Common Elements reserved for the exclusive use of the Owners and Occupants of the Units to which they are allocated, and the rights to the use and enjoyment thereof are automatically conveyed with the conveyance of such Units. The Limited Common Elements are described and allocated to the Units as follows

a. Chutes, flues, ducts, pipes, wires, conduit or other utility installations, bearing walls, bearing columns, or any other components or fixtures lying partially within and partially outside the boundaries of a Unit, and serving only that Unit, are allocated to the Unit they serve. Any portion of such installations serving or affecting the function of more than one Unit or any portion of the Common Elements is a part of the Common Elements, but is not a Limited Common Element.

ARTICLE IV
ASSOCIATION MEMBERSHIP: RIGHTS AND OBLIGATIONS

Membership in the Association, and the allocation to each Unit of a portion of the votes in the Association and a portion of the Common Expenses of the Association shall be governed by the following provisions:

4.1 Membership Each Owner shall be a member of the Association by virtue of Unit ownership, and the membership shall be transferred with the conveyance of the Owner's interest in the Unit. An Owner's membership shall terminate when the Owner's ownership terminates. When more than one Person is an Owner of a Unit, all such Persons shall be members of the Association, but multiple ownership of a Unit shall not increase the voting rights allocated to such Unit nor authorize the division of the voting rights.

4.2 Voting and Common Expenses Voting rights and Common Expense obligations are allocated equally among the Units, except that special allocations of Common Expenses shall be permitted as provided in Section 6.1.

4.3 Appurtenant Rights and Obligations The ownership of a Unit shall include the voting rights and Common Expense obligations described in Section 4.2. Said rights, obligations and interests, and the title to the Units, shall not be separated or conveyed separately. The allocation of the rights, obligations, and interests described in this Section may not be changed, except in accordance with the Governing Documents and the Act.

4.4 Authority to Vote The Owner, or some natural person designated to act as proxy on behalf of the Owner, and who need not be an Owner, may cast the vote allocated to such Unit at meetings of the Association, provided, that if there are multiple Owners of a Unit, only the Owner or other Person designated pursuant to the provisions of the By-Laws may cast such vote. The voting rights of Owners are more fully described in Section 3 of the By-Laws.

4.5 Declarant Control. Notwithstanding the vote of any Unit Owner to the contrary, the Declarant hereby reserves a period of Declarant control of the Association during which the Declarant, or person designated by the Declarant, may appoint and remove the officers and directors of the Association. Said reservation of Declarant control is subject to the following:

a. The maximum period of Declarant control may extend from the date of the first conveyance of a Unit to a Unit Owner other than a Declarant for a period not exceeding five (5) years.

b. Notwithstanding subsection 4.5.1 above, the period of Declarant control shall terminate upon the earlier of (i) surrender of control by the Declarant, or (ii) sixty (60) days after conveyance of seventy-five percent (75%) of the Units to Unit Owners other than Declarant.

c. Not later than sixty (60) days after conveyance of fifty percent (50%) of the Units that may be created to Unit Owners other than Declarant or an affiliate of Declarant, a meeting of the Unit Owners shall be held at which not less than thirty-three

and one-third percent (33-1/3%) of the members of the Board shall be elected by Unit Owners other than Declarant or an affiliate of Declarant

d. Not later than the termination of Declarant control, the Unit Owners shall elect a Board of Directors of at least three members. Thereafter, a majority of the directors shall be Unit Owners other than Declarant or an affiliate of Declarant. The remaining directors need not be Unit Owners unless required by the Articles of Incorporation or By-Laws. All Unit Owners, including the Declarant or its affiliates, may cast the votes allocated to any Unit owned by them. The Board shall elect the officers. The directors and officers shall take office upon election.

e. In determining whether the period of Declarant control has terminated under Subsection 4.5 2, or whether Unit Owners other than a Declarant are entitled to elect members of the Board of Directors under Subsection 4.5 3, the percentage of the Units which have been conveyed shall be calculated based upon the assumption that all Units which the Declarant has built or reserved the right to build in this Declaration are included in the CIC.

f. Except as otherwise provided in this subsection, meetings of the Board of Directors must be open to all Unit Owners. To the extent practicable, the Board shall give reasonable notice to the Unit Owners of the date, time, and place of a Board meeting. If the date, time, and place of meetings are provided for in this Declaration, the Articles of Incorporation or Bylaws of the Association, were announced at a previous meeting of the Board, posted in a location accessible to the Unit Owners and designated by the Board from time to time, or if an emergency requires immediate consideration of a matter by the Board, notice is not required. "Notice" has the meaning given in Minnesota Statutes Section 317A.011, subdivision 14. Meetings may be closed to discuss the following.

i personnel matters,

ii pending or potential litigation, arbitration, or other potentially adversarial proceedings, between Unit Owners, between the Board or Association and Unit Owners, or other matters in which any Unit Owner may have an adversarial interest, if the Board determines that closing the meeting is necessary to discuss strategy or to otherwise protect the position of the Board or Association or the privacy of a Unit Owner or occupant of a Unit; or

iii criminal activity arising within the CIC if the Board determines that closing the meeting is necessary to protect the privacy of the victim or that opening the meeting would jeopardize the investigation of the activity.

Nothing in this subsection imposes a duty upon the Board to provide special facilities for meetings. The failure to give notice as required by this subsection shall not invalidate the Board meeting or any action taken at the meeting.

ARTICLE V
ADMINISTRATION

The administration and operation of the Association and the Property, including, but not limited to, the acts required of the Association, shall be governed by the following provisions:

5.1 General The operation and administration of the Association and the Property shall be governed by the Governing Documents and the Act. The Association shall, subject to the rights of the Owners set forth in the Governing Documents and the Act, be responsible for the operation, management and control of the Property. The Association shall have all powers described in the Governing Documents, the Act and the statute under which it is incorporated. All power and authority of the Association shall be vested in the Board, unless action or approval by the individual Owners is specifically required by the Governing Documents or the Act. All references to the Association shall mean the Association acting through the Board unless specifically stated to the contrary. Specifically, the Association shall have the power to

a. adopt, amend and revoke rules and regulations not inconsistent with the articles of incorporation, Bylaws and Declaration, as follows. (i) regulating the use of the Common Elements, (ii) regulating the use of the Units, and conduct of Owners and Occupants, which may jeopardize the health, safety or welfare of other Occupants, which involves noise or other disturbing activity, or which may damage the Common Elements or other units; (iii) regulating or prohibiting animals, (iv) regulating changes in the appearance of the Common Elements and conduct which may damage the common interest community, (v) regulating the exterior appearance of the common interest community, including, for example, balconies and patios, window treatments, and signs and other displays, regardless of whether inside a Unit; (vi) implementing the articles of incorporation, Declaration and Bylaws, and exercising the powers granted by this section, and (vii) otherwise facilitating the operation of the common interest community,

b. adopt and amend budgets for revenues, expenditures and reserves, and levy and collect assessments for Common Expenses from Unit Owners;

c. hire and discharge managing agents and other employees, agents, and independent contractors,

d. institute, defend, or intervene in litigation or administrative proceedings (i) in its own name on behalf of itself or two or more Unit Owners on matters affecting the Common Elements or other matters affecting the common interest community or, (ii) with the consent of the Owners of the affected Units on matters affecting only those Units,

e. make contracts and incur liabilities,

f. regulate the use, maintenance, repair, replacement and modification of the Common Elements and the Units;

g. acquire, hold, encumber, and convey in its own name any right, title, or interest to real estate or personal property.

h. grant public utility easements through, over or under the Common Elements, and, subject to approval by resolution of Unit Owners other than Declarant or its affiliates at a meeting duly called, grant other public or private easements, leases and licenses through, over or under the Common Elements,

i. impose and receive any payments, fees, or charges for the use, rental, or operation of the Common Elements, other than Limited Common Elements, and for services provided to Unit Owners,

j. impose charges for late payment of assessments and, after notice and an opportunity to be heard, levy reasonable fines for violations of the Declaration, Bylaws, and rules and regulations of the Association,

k. impose reasonable charges for the review, preparation and recordation of amendments to the Declaration, resale certificates required by section 515B 4-107, statements of unpaid assessments, or furnishing copies of Association records,

l. provide for the indemnification of its officers and directors, and maintain directors' and officers' liability insurance,

m. provide for reasonable procedures governing the conduct of meetings and election of directors,

n. exercise any other powers conferred by law, or by the Declaration, articles of incorporation or Bylaws, and

o. exercise any of the powers necessary and proper for the governance and operation of the Association

5.2 Operational Purposes. The Association shall operate and manage the Property for the purposes of (i) administering and enforcing the covenants, restrictions, easements, charges and liens set forth in the Governing Documents and the Rules and Regulations (ii) maintaining, repairing and replacing those portions of the Property for which it is responsible, and (iii) preserving the value and architectural uniformity and character of the Property

5.3 Binding Effect of Actions All agreements and determinations made by the Association in accordance with the powers and voting rights established by the Governing Documents or the Act shall be binding upon all Owners and Occupants, and their lessees, guests, heirs, personal representatives, successors and assigns and all secured parties as defined in the Act.

5.4 By-Laws The Association shall have By-Laws. The By-Laws and any amendments thereto shall govern the operation and administration of the Association

5.5 Management The Board may delegate to a manager or managing agent the management duties imposed upon the Association's officers and directors by the Governing Documents and the Act, provided, however, that such delegation shall not relieve the officers

and directors of the ultimate responsibility for the performance of their duties as prescribed by the Governing Documents and by law

5.6 Rules and Regulations The Board shall have exclusive authority to approve and implement such reasonable Rules and Regulations as it deems necessary from time to time for the purpose of operating and administering the affairs of the Association and regulating the use of the Property; provided that the Rules and Regulations shall not be inconsistent with the Governing Documents or the Act. The inclusion in other parts of the Governing Documents of authority to approve Rules and Regulations shall be deemed to be in furtherance, and not in limitation, of the authority granted by this Section. New or amended Rules and Regulations shall be effective only after reasonable notice thereof has been given to the Owners.

5.7 Association Assets; Surplus Funds All funds and real or personal property acquired by the Association shall be held and used for the benefit of the Owners for the purposes stated in the Governing Documents. Surplus funds remaining after payment of or provision for Common Expenses and reserves shall be credited against future assessments or added to reserves, as determined by the Board.

ARTICLE VI **ASSESSMENTS FOR COMMON EXPENSES**

6.1 General Assessments for Common Expenses shall be determined and assessed against the Units. Assessments for Common Expenses shall include annual assessments and may include special assessments. Assessments shall be allocated among the Units according to the Common expense allocations set forth in Section 4.2, subject to the following qualifications:

a. Any Common Expense associated with the maintenance, repair, or replacement of a Limited Common Element undertaken by the Association may be assessed exclusively against the Unit or Units to which that Limited Common Element is assigned, on the basis of (i) equality, (ii) square footage of the area being maintained, repaired, or replaced, or (iii) the actual cost incurred with respect to each Unit.

b. Any Common Expense or portion thereof benefiting fewer than all of the Units may be assessed exclusively against the Units benefited, on the basis of (i) equality, (ii) square footage of the area being maintained, repaired or replaced, or (iii) the actual cost incurred with respect to each Unit.

c. The costs of insurance may be assessed in proportion to value, risk or coverage, and the costs of utilities may be assessed in proportion to usage.

d. Reasonable attorneys' fees and other costs incurred by the Association in connection with (i) the collection of assessments, and (ii) the enforcement of the Governing Documents, the Act, or the Rules and Regulations, against an Owner or Occupant or their guests, may be assessed against the Owner's Unit.

e. Fees, charges, late charges, fines, and interest may be assessed as provided in Section 515B 3-116(a) of the Act.

f Assessments levied under Section 515B 3-116 of the Act to pay a judgment against the Association may be levied only against the Units existing at the time the judgment was entered, in proportion to their Common Expense liabilities

g. If any damage to the Common Elements or another Unit is caused by the act or omission of any Owner or Occupant, or their guests, the Association may assess the costs of repairing the damage exclusively against the Owner's Unit to the extent not covered by insurance

h If any installment of an assessment becomes more than 30 days past due, then the Association may, upon 10 days written notice to the Owner, declare the entire amount of the assessment immediately due and payable in full

i If Common Expense liabilities are reallocated for any purpose authorized by the Act, Common Expense assessments and any installments thereof not yet due shall be recalculated in accordance with the reallocated Common Expense liabilities

j. Assessments under this Subsection 6 1 shall not be considered special assessments as described in Section 6 3

6.2 Annual Assessments Annual assessments shall be established and levied by the Board Each annual assessment shall cover all of the anticipated Common Expenses of the Association for that year. Annual assessments shall provide, among other things, for contributions to a separate reserve fund sufficient to cover the periodic cost of maintenance, repair, and replacement of the Common Elements and those parts of the Units for which the Association is responsible

a Until a Common Expense assessment is levied, Declarant shall pay all accrued expenses of the common interest community.

b After a Common Expense assessment is levied, the annual assessment may be subsequently increased by the Board

6.3 Special Assessments In addition to annual assessments, and subject to the limitations set forth hereafter, the Board may levy in any assessment year a special assessment against Units for the purpose of defraying in whole or in part (i) the cost of any unforeseen or unbudgeted Common Expense, (ii) general or specific reserves for maintenance, repair, or replacement, (iii) the maintenance, repair, or replacement of any part of the Property, and any fixtures or other property related thereto, and (iv) fees and expenses incurred pursuant to Section 8 10 Such special assessments will be levied against all Units, or those Units benefiting from the expenditure. Notwithstanding the foregoing, any special assessment shall be subject to approval by the vote of a majority of those Owners voting, in person or by proxy, at a meeting called for that purpose Written notice of the meeting shall be sent to all Owners not less than 21 days nor more than 30 days in advance of the meeting

6.4 Working Capital Fund Declarant shall establish a working capital fund to meet unforeseen expenditures or to purchase additional equipment or services during the period when Declarant is conducting its sales activities, which shall be funded to the extent payments are

made by Unit purchasers as herein provided. There shall be contributed by each Unit purchaser from Declarant on a one-time basis for each Unit sold by Declarant an amount equal to two (2) months installments of the estimated Common Expense assessment for the Unit being conveyed. The contribution to the working capital fund shall be paid at the time of closing of sale of the Unit. The amounts paid into this fund are in addition to the regular monthly installments of assessments. The funds shall be deposited into the Association's account, and Declarant may not use the funds to defray any of its expenses, reserve contributions, or construction costs, or to make up any budget deficit while Declarant is in control of the Association. However, upon closing of an unsold Unit, Declarant may reimburse itself from funds collected at the closing for funds which it contributed to the working capital fund with respect to that Unit.

6.5 Liability of Owners for Assessments The obligation of an Owner to pay assessments shall commence at the later of (i) the recording of this Declaration or amendment thereto which creates the Owner's Unit, or (ii) the time at which the Owner acquires title to the Unit, subject to the alternative assessment program described in Section 6.6. The Owner at the time an assessment is payable with respect to the Unit shall be personally liable for the share of the Common Expenses assessed against such Unit. Such liability shall be joint and several where there are multiple Owners of the Unit. The liability is absolute and unconditional. No Owner is exempt from liability for payment of his or her share of Common Expenses by right of set-off, by waiver of use or enjoyment of any part of the Property, by absence from or abandonment of the Unit, by the waiver of any other rights, or by reason of any claim against the Association or its officers, directors, or agents, or for their failure to fulfill any duties under the Governing Documents or the Act. The Association may invoke the charges, sanctions and remedies set forth in Section 14, in addition to any remedies provided elsewhere in the Governing Documents or by law, for the purpose of enforcing its rights hereunder.

6.6 Declarant's Alternative Assessment Program Notwithstanding anything to the contrary in this Section 6, if a Common Expense assessment has been levied, any Unit owned by Declarant for initial sale shall be assessed at the rate of 25% of the assessment levied on other Units of the same type until a certificate of occupancy has been issued with respect to such Unit by the municipality in which the Unit is located. This reduced assessment shall apply to each Unit owned by Declarant at the time that the Unit is created, and shall continue until the issuance of the certificate of occupancy as previously described. There are no assurances that this alternative assessment program will have no effect on the level of services for items set forth in the Association's budget.

6.7 Assessment Lien The Association has a lien on a Unit for any assessment levied against that Unit from the time the assessment becomes due. If an assessment is payable in installments, the full amount of the assessment is a lien from the time the first installment thereof becomes due. Fees, charges, late charges, fines, and interest charges imposed by the Association pursuant to Section 515B 3-102(a)(10), (11) and (12) of the Act are liens, and are enforceable as assessments, under this Section. Recording of this Declaration constitutes record notice and perfection of any lien under this Section, and no further recordation of any notice of or claim for the lien is required.

6.8 Foreclosure of Lien; Remedies A lien for Common Expenses may be foreclosed against a Unit under the laws of the State of Minnesota (i) by action, or (ii) by

advertisement as a lien under a mortgage containing a power of sale. The Association, or its authorized representative, shall have the power to bid in at the foreclosure sale and to acquire, hold, lease, mortgage and convey a Unit so acquired. The Owner and any other Person claiming an interest in the Unit, by the acceptance or assertion of any interest in the Unit, grants to the Association a power of sale and full authority to accomplish the foreclosure. The Association shall, in addition, have the right to pursue any other remedy at law or in equity against the Owner who fails to pay any assessment or charge against the Unit.

6.9 Lien Priority; Foreclosure A lien under this Section is prior to all other liens and encumbrances on a Unit except (i) liens and encumbrances recorded before this Declaration, (ii) any first mortgage on the Unit, and (iii) liens for real estate taxes and other governmental assessments or charges against the Unit. Notwithstanding the foregoing, if a first mortgage on a Unit is foreclosed and no Owner redeems during the Owner's period of redemption provided by Chapters 580, 581, or 582, then the holder of the sheriff's certificate of sale from the foreclosure of the first mortgage shall take title to the Unit subject to unpaid assessments for Common Expenses which became due, without acceleration, during the six months immediately preceding the first day following the end of the Owner's period of redemption.

6.10 Voluntary Conveyances; Statement of Assessments. In a voluntary conveyance of a Unit, the buyer shall not be personally liable for any unpaid assessments and other charges made by the Association against the seller or the seller's Unit prior to the time of conveyance to the buyer, unless expressly assumed by the buyer. However, the lien of such assessments shall remain against the Unit until satisfied. Any seller or buyer shall be entitled to a statement, in recordable form, from the Association setting forth the amount of the unpaid assessments against the Unit, including all assessments payable in the Association's current fiscal year, which statement shall be binding on the Association, seller and buyer.

ARTICLE VII **RESTRICTIONS ON USE OF PROPERTY**

All Owners and Occupants, and all secured parties, by their acceptance or assertion of an interest in the Property, or by their occupancy of a Unit, covenant and agree that, in addition to any other restrictions which may be imposed by the Act or the Governing Documents, the occupancy, use, operation, alienation, and conveyance of the Property shall be subject to the following restrictions:

7.1 General The Property shall be owned, conveyed, encumbered, leased, used, and occupied subject to the Governing Documents and the Act, as amended from time to time. All covenants, restrictions and obligations set forth in the Governing Documents are in furtherance of a plan for the Property, and shall run with the Property and be a burden and benefit to all Owners and Occupants and to any other Person acquiring or owning an interest in the Property, their heirs, personal representatives, successors and assigns.

7.2 Subdivision Prohibited Except as permitted by the Act, no Unit nor any part of the Common Elements may be subdivided or partitioned without the prior written approval of all Owners and all secured parties holding first mortgages on the Units.

7.3 Residential Use. The Units shall be used by Owners and Occupants and their guests exclusively as private, single-family residential dwellings, and not for transient, hotel, commercial, business or other non-residential purposes, except as provided in Section 7.4. Any lease of a Unit (except for occupancy by guests with the consent of the Owner) for a period of less than seven (7) days, or any occupancy which includes services customarily furnished to hotel guests, shall be presumed to be for transient purposes.

7.4 Business Use Restricted. No business, trade, occupation or profession of any kind, whether carried on for profit or otherwise, shall be conducted, maintained or permitted in any Unit or the Common Elements, except (i) an Owner or Occupant residing in a Unit may keep and maintain his or her business or professional records in such Unit and handle matters relating to such business by telephone or correspondence therefrom, provided that such uses are incidental to the residential use, do not involve physical alteration of the Unit and do not involve any observable business activity such as signs, advertising displays, bulk mailings, deliveries, or visitation or use of the Unit by customers or employees and (ii) the Association may maintain offices on the Property for management and related purposes.

7.5 Leasing. Leasing of the Units shall be allowed, subject to reasonable regulation by the Association, and subject to the following conditions: (i) that no Unit shall be leased for transient or hotel purposes, (ii) that no Unit may be subleased, (iii) that all leases shall be in writing, and (iv) that all leases shall provide that they are subordinate and subject to the provisions of the Governing Documents, the Rules and Regulations and the Act and that any failure of the lessee to comply with the terms of such documents shall be a default under the lease. The Association may impose such reasonable Rules and Regulations as may be necessary to implement procedures for the leasing of Units, consistent with this Section.

7.6 Parking. Garages and parking areas on the Property shall be used only for parking of vehicles owned or leased by Owners and Occupants and their guests, and such other incidental uses as may be authorized in writing by the Association. The use of garages, driveways, and other parking areas on the Property, and the types of vehicles and personal property permitted thereon, shall be subject to regulation by the Association, including without limitation the right of the Association to tow illegally parked vehicles or to remove unauthorized personal property.

7.7 Animals. No animal may be bred, or kept or maintained for business or commercial purposes, anywhere on the Property. However, the Board shall have the exclusive authority to prohibit, or to allow and regulate, by Rules and Regulations, the keeping of animals on the Property. The word "animal" shall be construed in its broadest sense and shall include all living creatures except humans.

7.8 Quiet Enjoyment; Interference Prohibited. All Owners and Occupants and their guests shall have a right of quiet enjoyment in their respective Units, and shall use the Property in such a manner as will not cause a nuisance, nor unduly restrict, interfere with or impede the use of the Property by other Owners and Occupants and their guests.

7.9 Compliance with Law. No use shall be made of the Property which would violate any then existing municipal codes or ordinances, or state or federal laws, nor shall any act

or use be permitted which could cause waste to the Property, cause a material increase in insurance rates on the Property, or otherwise cause any unusual liability, health, or safety risk, or expense, for the Association or any Owner or Occupant

7.10 Alterations. Except for those made by Declarant in consideration of its initial sale of a Unit, no alterations, changes, improvements, repairs, or replacements of any type, temporary or permanent, structural, aesthetic, or otherwise (collectively referred to as "alterations") shall be made, or caused or allowed to be made, by any Owner or Occupant, or their guests, in any part of the Common Elements, or in any part of the Unit which affects the Common Elements or which is visible from the exterior of the Unit, without the prior written authorization of the Board, or a committee appointed by it, as provided in Section 8. The Board, or the appointed committee if so authorized by the Board, shall have the authority to establish reasonable criteria and requirements for alterations, and shall be the sole judge of whether the criteria are satisfied

7.11 Time Shares Prohibited The time share form of ownership, or any comparable form of lease, occupancy rights or ownership which has the effect of dividing the ownership or occupancy of a Unit into separate time periods, is prohibited

7.12 Access to Units In case of emergency, all Units and Limited Common Elements are subject to entry, without notice and at any time, by an officer or member of the Board of the Association, by the Association's management agents or by any public safety personnel. Entry is also authorized for maintenance purposes under Section 9 and for enforcement purposes under Section 14

7.13 Offensive Activities. No noxious or offensive activity shall take place in or on any Unit, nor shall anything be done thereon, which may be or become an annoyance or nuisance to adjoining occupants of Units .

7.14 Outside Storage; Temporary Structures

No structure of a temporary character, trailer, recreational vehicle or detached building or structure shall be permitted except as required by the Declarant in the course of installing streets and utilities for the Property No recreational vehicle, non-operative automobile, fish house, firewood or vehicle in excess of 9,000 pounds gross vehicle weight shall be kept or stored outside of a Unit At no time shall there be any parking or outside storage of any vehicle off of the hard surface driveway.

All clotheslines and playground equipment shall be placed in the rear yard of the Unit only

7.15 Rubbish. No lot shall be used or maintained as a dumping ground for rubbish Trash, garbage or other waste shall not be kept except in sanitary containers. Such containers shall be kept in a clean and sanitary condition and screened completely from view or site if located outside a building. The contents of all such containers shall be emptied not less than weekly No substance or material shall be kept which will emit a foul, obnoxious or offensive order

7.16 Utilities All Units shall be served by underground utilities including gas, electricity, telephone and cable. No above ground poles or wires may be used except for temporary construction or repair. All utility meters shall be concealed from view from the street or shall be architecturally treated to blend in with the townhome

7.17 Accessory Buildings No storage, accessory building or other shed shall be permitted on any Unit Notwithstanding any other language to the contrary, a dog house is permitted provided it is not greater than eight square feet, is the same color as the home, is not in any setback areas and is located immediately adjacent to the home

7.18 Water Wells and Septic Tanks. No private water wells may be drilled or maintained and no septic tanks or similar sewage facilities or irrigation or sprinkler system may be installed or maintained in any lot or dwelling on the lot Irrigation or sprinkler systems may be installed and maintained provided that they are connected to city water.

7.19 Construction and Sales Activities Notwithstanding any provisions of this document to the contrary, so long as the Declarant shall own any of the lots described in Exhibits A or B hereto, it shall be expressly permissible for Declarant and its contractors, subcontractors, agents, employees, successors and assigns to carry on such activities as reasonably required by or incidental to the improvement of the lots and dwellings thereon, and to construct, maintain, and operate model homes and other development, sales and rental facilities on any Unit within the Property owned by the Declarant

ARTICLE VIII **ARCHITECTURAL AND LANDSCAPE STANDARDS**

8.1 General It is the intent of Declarant to create a general plan and uniform scheme of development of the Property and to create within the Property a residential community of high quality and harmonious improvements Accordingly, an architectural review committee (the "A R C.") may be established as a permanent committee of the Association, to oversee, review and regulate all architectural and design matters involving the Property

ARTICLE IX **MAINTENANCE**

9.1 Maintenance by Association. The Association shall provide for all maintenance, repair or replacement (collectively referred to as "maintenance") of the Common Elements In addition, for the purpose of preserving the architectural character, quality, and uniform and high standards for appearance of the Property, the Association shall (i) provide for exterior maintenance upon each Unit that is subject to assessment as follows paint and replace roofs, gutters, downspouts, decks, garage doors (except hardware), and exterior siding and other building surfaces, and (ii) provide for lawn, shrub and tree maintenance on all Units; (iii) provide for snow removal from driveways, walkways and parking areas for all Units, (iv) maintain any entrance monument or monuments provided by the Declarant, and (v) maintain the private roadway, storm water system and ponds. The Association's obligation to maintain exterior building surfaces shall exclude patios, entry doors, door hardware, air conditioning equipment, glass and window frames, and any other items not specifically referred to in this Section The

Association shall have easements as described in Section 13 to perform its obligations under this Section 9.

9.2 Optional Maintenance by Association In addition to the maintenance described in this Section the Association may, with the approval of a majority of votes cast in person or by proxy at a meeting called for such purpose, undertake to provide additional exterior maintenance to the Units, or maintenance of water and sewer systems within the Units

9.3 Maintenance by Owner Except for the exterior maintenance required to be provided by the Association, all maintenance of the Units shall be the sole responsibility and expense of the Owners thereof. However, the Owners and Occupants shall have a duty to promptly notify the Association of defects in or damage to those parts of the Property which the Association is obligated to maintain. The Association may require that any exterior maintenance to be performed by the Owner be accomplished pursuant to specific uniform criteria established by the Association. The Association may also undertake any exterior maintenance which the responsible Owner fails to or improperly performs and assess the Unit and the Owner for the cost thereof.

9.4 Damage Caused by Owner Notwithstanding any provision to the contrary in this Section, if, in the judgment of the Association, the need for maintenance of any part of the Property is caused by the willful or negligent act or omission of an Owner or Occupant, or their guests, or by a condition in a Unit which the Owner or Occupant has willfully or negligently allowed to exist, the Association may cause such damage or condition to be repaired or corrected (and enter upon any Unit to do so), and the cost thereof may be assessed against the Unit of the Owner responsible for the damage. In the case of party walls between Dwellings, the Owners of the affected Dwellings shall be liable as provided in Section 10

ARTICLE X **PARTY WALLS**

10.1 General Rules of Law to Apply. Each wall built as part of the original construction of the Dwellings and located on the boundary line between Units shall constitute a party wall and, to the extent not inconsistent with the provisions of this Section, the general rules of law regarding party walls and liability for property damage due to negligent or willful acts or omissions shall apply thereto

10.2 Repair and Maintenance The Owners of the Units which share the party wall shall be responsible for the maintenance, repair and replacement of the party wall in proportion with their use, provided (i) that any maintenance, repair or replacement necessary due to the acts or omissions of a certain Owner or Occupant sharing such party wall shall be paid for by such Owner, and (ii) that the Association may contract for and supervise the repair of damage caused by an Owner or Occupant and assess the responsible Owner(s) for their respective shares of the cost to the extent not covered by insurance

10.3 Destruction by Fire or Other Casualty If a party wall is destroyed or damaged by fire or other casualty, any owner who has use of the wall may, with the consent of the Association, restore it, and the other Owner shall promptly reimburse the Owner who restored

the wall for his or her share of the cost of restoration thereof, provided, however, that the cost of restoration resulting from destruction or other casualty resulting from the acts or omissions of certain Owners shall be the financial responsibility of such Owners, and the Association may assess the responsible Owners for their share of the costs, without prejudice to the right of an Owner to recover a larger contribution from the other Owner. Insurance claims shall be made promptly following any casualty.

10.4 Weatherproofing Notwithstanding any other provision of this Section, any Owner who, by his negligent or willful act, causes a party wall to be exposed to the elements shall bear the whole cost of the repairs necessary for protection against such elements

10.5 Right to Contribution Runs With Land The right of any Owner to contribution from any other Owner under this Section shall be appurtenant to the Unit and shall pass to such Owner's assigns and successors in title.

10.6 Arbitration In the event of any dispute arising concerning a party wall, and if the same is not resolved within thirty (30) days of the event causing the dispute, the matter shall be submitted to binding arbitration under the rules of the American Arbitration Association, upon the written demand of the Association or any Owner whose Dwelling shares the party wall. Each party agrees that the decision of the arbitrators shall be final and conclusive regarding the questions before the Arbitrator(s). The fees of the arbitrators shall be shared equally by the parties, but each party shall pay its own attorney fees or other costs to prove its case.

ARTICLE XI **INSURANCE**

11.1 Required Coverage The Association shall obtain and maintain, to the extent reasonably available at a reasonable cost, a policy or policies of insurance in accordance with the insurance requirements as set forth in the Act and the requirements set forth herein, issued by a reputable insurance company or companies authorized to do business in the State of Minnesota, as follows:

a. Property insurance in broad form covering all risks of physical loss in an amount equal to one hundred percent (100%) of the insurable "replacement cost" of the Property, less deductibles, exclusive of land, footings, excavation and other items normally excluded from coverage (but including all building service equipment and machinery). The policy or policies shall cover personal property owned by the Association. The policy or policies shall also contain "Inflation Guard" and "Agreed Amount" endorsements, if reasonably available. Such policy or policies shall include such additional endorsements, coverages, and limits with respect to the foregoing and other hazards as may be required from time to time by the regulations of the Federal Housing Administration ("FHA") or Federal National Mortgage Association ("FNMA") as a precondition to their insuring, purchasing or financing a mortgage on a Unit. The Board may also, on behalf of the Association, enter into binding written agreements with a mortgagee, insurer or servicer, including, without limitation, the FHA or FNMA, obligating the Association to keep certain specified coverages or endorsements in effect.

b. Comprehensive public liability insurance covering the use, operation and maintenance of the Common Elements, with minimum limits of \$1,000,000 00 per occurrence, against claims of death, bodily injury and property damage, and such other risks as are customarily covered by such policies for projects similar in construction, location and use to the Property. The policy shall contain a "severability of interest" endorsement which shall preclude the insurer from denying the claim of an Owner or Occupant because of negligent acts of the Association or other Owners or Occupants. The policy shall include such additional endorsements, coverages, and limits with respect to such hazards as may be required by the regulations of the FHA or FNMA as a precondition to their insuring, purchasing or financing a mortgage on a Unit.

c. Fidelity bond or insurance coverage against dishonest acts on the part of directors, officers, managers, trustees, employees or persons responsible for handling funds belonging to or administered by the Association if deemed to be advisable by the Board or required by the regulations of the FHA or FNMA as a precondition to insuring, purchasing or financing of a mortgage on a Unit. The fidelity bond or insurance shall name the Association as the named insured and shall, if required by the regulations of the FHA or FNMA as a precondition to their insuring, purchasing or financing of a mortgage on a Unit, be written in an amount equal to the greater of (i) the estimated maximum of Association funds, including reserves, in the custody of the Association or management agent at any given time while the bond is in force, or (ii) a sum equal to three months aggregate assessments on all Units plus reserve. An appropriate endorsement to the policy to cover any persons who serve without compensation shall be added if the policy would not otherwise cover volunteers, or a waiver of defense based upon the exclusion of persons serving without compensation shall be added.

d. Workers' Compensation insurance as required by law.

e. Directors and officers liability insurance with such reasonable limits and coverages as the Board shall determine from time to time.

f. Such other insurance as the Board may determine from time to time to be in the best interests of the Association and the Owners.

11.2 Premiums; Improvements; Deductibles. All insurance premiums shall be assessed and paid as a Common Expense. The insurance need not cover improvements and betterments to the Units installed by Owners, but if improvements and betterments are covered, any increased cost may be assessed against the Units affected. The Association may, in the case of a claim for damage to a Unit, (i) pay the deductible amount as a Common Expense, (ii) assess the deductible amount against the Units affected in any reasonable manner, or (iii) require the Owners of the Units affected to pay the deductible amount directly.

11.3 Loss Payee; Insurance Trustee. All insurance coverage maintained by the Association shall be written in the name of, and the proceeds thereof shall be payable to, the Association (or a qualified insurance trustee selected by it) as trustee for the benefit of the Owners and secured parties, including Eligible Mortgagees, which suffer loss. The Association,

or any insurance trustee selected by it, shall have exclusive authority to negotiate, settle, and collect upon any claims or losses under any insurance policy maintained by the Association

11.4 Required Policy Provisions. All policies of property insurance carried by the Association shall provide that

a. Each Owner and secured party is an insured Person under the policy with respect to liability arising out of the Owner's interest in the Common Elements or membership in the Association

b. The insurer waives its right to subrogation under the policy against any Owner or member of the Owner's household and against the Association and members of the Board.

c. The coverage shall not be voided by or conditioned upon (i) any act or omission of an Owner or Eligible Mortgagee, unless acting within the scope of authority on behalf of the Association, or (ii) any failure of the Association to comply with any warranty or condition regarding any portion of the Property over which the Association has no control.

d. If at the time of a loss under the policy there is other insurance in the name of an Owner covering the same property covered by the policy, the Association's policy is primary

11.5 Cancellation; Notice of Loss. All policies of property insurance and comprehensive liability insurance maintained by the Association shall provide that the policies shall not be canceled or substantially modified, for any reason, without at least 30 days prior written notice to the Association, to the FHA or FNMA (if applicable), all of the insureds and all Eligible Mortgagees

11.6 Restoration in Lieu of Cash Settlement. All policies of property insurance maintained by the Association shall provide that, despite any provisions giving the insurer the right to elect to restore damage in lieu of a cash settlement, such option shall not be exercisable (i) without the prior written approval of the Association (or any insurance trustee) or (ii) when in conflict with provisions of any insurance trust agreement to which the Association may be a party, or any requirement of law

11.7 Association Insurance Primary. All policies of insurance maintained by the Association shall be the primary insurance

11.8 Effect of Acts Not Within Association's Control All policies of insurance maintained by the Association shall provide that the coverage shall not be voided by or conditioned upon (i) any act or omission of an Owner or Eligible Mortgagee, unless acting within the scope of authority on behalf of the Association, or (ii) any failure of the Association to comply with any warranty or condition regarding any portion of the Property over which the Association has no control

11.9 Owner's Personal Insurance Each Owner may obtain additional personal insurance coverage at his or her own expense covering fire and other casualty to the Unit, personal property or personal liability. All insurance policies maintained by Owners shall provide that they are without contribution as against the insurance purchased by the Association

ARTICLE XII **RECONSTRUCTION, CONDEMNATION AND EMINENT DOMAIN**

12.1 Reconstruction The obligations and procedures for the repair, reconstruction or disposition of the Property following damage to or destruction thereof shall be governed by the Act. Any repair or reconstruction shall be substantially in accordance with the plans and specifications of the Property as initially constructed and subsequently improved upon. Notice of substantial damage or destruction shall be given pursuant to Section 18 10

12.2 Condemnation and Eminent Domain In the event of a taking of any part of the Property by condemnation or eminent domain, the provisions of the Act shall govern; provided, that notice shall be given pursuant to Section 18 10. Eligible Mortgagees shall be entitled to priority for condemnation awards in accordance with the priorities established by the Act and the Governing Documents, as their interests may appear.

12.3 Notice All Eligible Mortgagees shall be entitled to receive notice of any condemnation proceedings or substantial destruction of the Property, and the Association shall give written notice thereof to a Eligible Mortgagee pursuant to Section 18 10

ARTICLE XIII **EASEMENTS**

13.1 Easement for Encroachments Each Unit and the Common Elements, and the rights of the Owners and Occupants therein, shall be subject to an exclusive easement for encroachments in favor of the adjoining Units for fireplaces, walls, roof overhangs, air conditioning systems, decks, balconies, patios, utility installations and other appurtenances (i) which are part of the original construction on the adjoining Unit or the Property or (ii) which are added pursuant to Section 8. If there is an encroachment by a Dwelling, or other building or improvement located in a Unit, upon another Unit or Dwelling as a result of the construction, reconstruction, repair, shifting, settlement or movement of any part of the Property, an appurtenant easement for the encroachment, for the use, enjoyment, and habitation of any encroaching Dwelling, building or improvement, and for the maintenance thereof, shall exist, provided that with respect to improvements or alterations added pursuant to Section 8, no easement shall exist unless the same have been approved and constructed as required by this Declaration. Such easements shall continue for as long as the encroachment exists and shall not affect the marketability of title.

13.2 Easement for Maintenance, Repair, Replacement, and Reconstruction Each Unit, and the rights of the Owner and Occupants thereof, shall be subject to the rights of the Association to an exclusive, appurtenant easement on and over the Units for the purposes of maintenance, repair, replacement and reconstruction of the Units, and utilities serving the Units, to the extent necessary to fulfill the Association's obligations under the Governing Documents.

13.3 Utilities Easements. The Property shall be subject to non-exclusive, appurtenant easements for all utilities, water and sewer, and similar services, which exist from time to time, as constructed or referred to in the Plat, or as otherwise described in this Declaration or any other duly recorded instrument. Each Unit, and the rights of the Owners and Occupants thereof, shall be subject to a non-exclusive easement in favor of the other Units for all such services, including without limitation, any sewer or water lines servicing other Units. Each Unit shall also be subject to an exclusive easement in favor of the Association and all utility companies providing service to the Units for the installation and maintenance of utility metering devices.

13.4 Continuation and Scope of Easements. Notwithstanding anything in this Declaration to the contrary, in no event shall an Owner or Occupant be denied reasonable access to his or her Unit or the right to utility services thereto. The easements set forth in this Section shall supplement and not limit any easements described elsewhere in this Declaration or recorded, and shall include reasonable access to the easement areas through the Units and the Common Elements for purposes of maintenance, repair, replacement and reconstruction.

13.5 Structural Encroachments. Except as otherwise specifically provided in this Section 13, no structural encroachments shall be allowed within easements.

ARTICLE XIV COMPLIANCE AND REMEDIES

Each Owner and Occupant, and any other Person owning or acquiring any interest in the Property, shall be governed by and comply with the provisions of the Act, the Governing Documents, the Rules and Regulations, the decisions of the Association, and such amendments thereto as may be made from time to time. A failure to comply shall entitle the Association to the relief set forth in this Section, in addition to the rights and remedies authorized elsewhere by the Governing Documents and the Act.

14.1 Entitlement to Relief The Association may commence legal action to recover sums due, for damages, for injunctive relief or to foreclose a lien owned by it, or any combination thereof, or an action for any other relief authorized by the Governing Documents or available at law or in equity. Legal relief may be sought by the Association against any Owner, or by an Owner against the Association or another Owner, to enforce compliance with the Governing Documents, the Rules and Regulations, the Act, or the decisions of the Association. However, no Owner may withhold any assessments payable to the Association, or take (or omit) other action in violation of the Governing Documents, the Rules and Regulations, or the Act, as a measure to enforce such Owner's position, or for any other reason.

14.2 Sanctions and Remedies In addition to any other remedies or sanctions, expressed or implied, administrative or legal, the Association shall have the right, but not the obligation, to implement any one or more of the following actions against Owners and Occupants and/or their guests, who violate the provisions of the Governing Documents, the Rules and Regulations or the Act:

a. Commence legal action for damages or equitable relief in any court of competent jurisdiction.

b. Impose late charges of up to 15% of each late payment of an assessment or installment thereof

c. In the event of default of more than 30 days in the payment of any assessment or installment thereof, all remaining installments of assessments assessed against the Unit owned by the defaulting Owner may be accelerated and shall then be payable in full if all delinquent assessments, together with all costs of collection and late charges, are not paid in full prior to the effective date of the acceleration. Reasonable advance written notice of the effective date of the acceleration shall be given to the defaulting Owner.

d. Impose reasonable fines, penalties or charges for each violation of the Act, the Governing Documents or the Rules and Regulations of the Association

e. Suspend the rights of any Owner or Occupant and their guests to use any Common Element amenities, provided, that this limitation shall not apply to Limited Common Elements or deck, balcony or patio easements, appurtenant to the Unit, and those portions of the Common Elements providing utility service and access to the Unit. Such suspensions shall be limited to periods of default by such Owners and Occupants in their obligations under the Governing Documents, and for up to 30 days thereafter, for each violation

f. Restore any portions of the Common Elements or Limited Common Elements damaged or altered, or allowed to be damaged or altered, by any Owner or Occupant or their guests in violation of the Governing Documents, and to assess the cost of such restoration against the responsible Owners and their Units.

g. Enter any Unit or Limited Common Element in which, or as to which, a violation or breach of the Governing Documents exists which materially affects, or is likely to materially affect in the near future, the health or safety of the other Owners or Occupants, or their guest, or the safety or soundness of any Dwelling or other part of the Property or the property of the Owners or Occupants, and to summarily abate and remove, at the expense of the offending Owner or Occupant, any structure, thing, or condition in the Unit or Limited Common Elements which is causing the violation; provided, that any improvements which are a part of a Unit may be altered or demolished only pursuant to a court order or with the agreement of the Owner

h. Foreclose any lien arising under the provisions of the Governing Documents or under law, in the manner provided for the foreclosure of mortgages by action or under a power of sale in the state where the Property is located

14.3 Rights to Hearing In the case of imposition of any of the remedies authorized by this Section, the Board shall, upon written request of the offender, grant to the offender a fair and equitable hearing as contemplated by the Act. The offender shall be given notice of the nature of the violation and the right to a hearing, and at least 10 days within which to request a hearing. The hearing shall be scheduled by the Board and held within thirty days of receipt of the hearing request by the Board, and with at least 10 days prior written notice to the offender. If

the offending Owner fails to appear at the hearing then the right to a hearing shall be waived and the Board may take such action as it deems appropriate. The decision of the Board and the rules for the conduct of hearings established by the Board shall be final and binding on all parties. The Board's decision shall be delivered in writing to the offender within ten days following the hearing, if not delivered to the offender at the hearing.

14.4 Lien for Charges, Penalties, Etc. Any assessments, charges, fines, penalties or interest imposed under this Section shall be a lien against the Unit of the Owner or Occupant against whom the same are imposed and the personal obligation of such Owner in the same manner and with the same priority and effect as assessments under Section 6. The lien shall attach as of the date of imposition of the remedy, but shall not be final as to violations for which a hearing is held until the Board gives written notice following the hearing. All remedies shall be cumulative, and the exercise of, or failure to exercise, any remedy shall not be deemed a waiver of the right to pursue any others.

14.5 Costs of Proceeding and Attorneys' Fees. With respect to any collection measures, or any measures or action, legal, administrative, or otherwise, which the Association takes to enforce the provisions of the Act, Governing Documents or Rules and Regulations, whether or not finally determined by a court or arbitrator, the Association may assess the violator and his or her Unit with any expenses incurred in connection with such enforcement, including without limitation fines or charges previously imposed by the Association, reasonable attorneys' fees, and interest (at the highest rate allowed by law) on the delinquent amounts owed to the Association.

14.6 Liability for Owners' and Occupants' Acts An Owner shall be liable for the expense of any maintenance, repair or replacement of the Property rendered necessary by such Owner's acts or omissions, or by that of Occupants or guests in the Owner's Unit, to the extent that such expense is not covered by the proceeds of insurance carried by the Association or such Owner or Occupant. However, any insurance deductible amount and/or increase in insurance rate resulting from the Owner's acts or omissions may be assessed against the Owner responsible for the condition and against his or her Unit.

14.7 Enforcement by Owners The provisions of this Section shall not limit or impair the independent rights of other Owners to enforce the provisions of the Governing Documents, the Rules and Regulations, and the Act as provided therein.

ARTICLE XV **SPECIAL DECLARANT RIGHTS**

Declarant hereby reserves exclusive and unconditional authority to exercise the following special declarant rights within the meaning of Section 515B.1-103(32) of the Act for as long as it owns a Unit, or for such shorter period as may be specifically indicated:

15.1 Complete Improvements To complete all the Units and other improvements indicated on the Plat, or otherwise included in Declarant's development plans or allowed by this Declaration, and to make alterations in the Units and Common Elements to accommodate its sales facilities.

15.2 Relocate Boundaries and Alter Units To relocate boundaries between Units and to otherwise alter Units owned by it, to the extent permitted by Section 16 2

15.3 Sales Facilities To construct, operate, and maintain a sales office, management office, model Units and other development, sales and rental facilities within the Common Elements and any Units owned by Declarant from time to time, located anywhere on the Property

15.4 Signs To erect and maintain signs and other sales displays offering the Units for sale or lease, in or on any Unit owned by Declarant and on the Common Elements

15.5 Easements To have and use easements for itself, its employees, contractors, representatives, agents, and prospective purchasers through and over the Common Elements for the purpose of exercising its special declarant rights.

15.6 Control of Association. To control the operation and administration of the Association, including, without limitation the power to appoint and remove the members of the Board pursuant to Section 515B.3-103 of the Act, until the earliest of (i) voluntary surrender of control by Declarant, (ii) an Association meeting which shall be held within 60 days after conveyance to Owners other than a Declarant of 75% of the total number of Units authorized to be included in the Property or (iii) the date five (5) years following the date of the first conveyance of a Unit to an Owner other than a Declarant. Notwithstanding the foregoing, the Owners other than a Declarant shall have the right to nominate and elect not less than 33-1/3% of the directors at a meeting of the Owners which shall be held within 60 days following the conveyance by Declarant of 50% of the total number of Units authorized to be included in the Property

15.7 Consent to Certain Amendments As long as Declarant owns any unsold Unit, Declarant's written consent shall be required for any amendment to the Governing Documents or Rules and Regulations which directly or indirectly affects or may affect Declarant's rights under the Governing Documents.

15.8 Appointments of Architectural Control Committee Declarant shall appoint the members of the Architectural Control Committee, as reflected in Section 8 2 1

ARTICLE XVI
RIGHTS TO ADD ADDITIONAL REAL ESTATE,
RELOCATE UNIT BOUNDARIES AND ALTER UNITS

16.1 Declarant's Rights to Add Additional Real Estate. Declarant does not reserve the right to add additional real estate to the Property

16.2 Rights to Relocate Boundaries and Alter Units Existing or future Units may be altered and Unit boundaries may be relocated only in accordance with the following conditions

a. **Combining Units** Subject to compliance with Section 8, an Owner may make improvements or alterations to such Unit or, may, after acquiring an adjoining Unit,

remove or alter any intervening partition or create apertures therein in accordance with Section 515B.2-113 of the Act and this Declaration

b. **Relocation of Boundaries.** The boundaries between adjoining Units may be relocated in accordance with Section 515B 2-114 of the Act and this Declaration

c. **Subdivision or Conversion** Additional Units may be created by the Declarant in the manner provided in Section 515B 2-112 of the Act by the subdivision or conversion of a Unit (within the meaning of the Act) into two or more Units, or into other Units, Common Elements or Limited Common Elements

d. **Requirements** The alteration, relocation of boundaries or other modification of Units or the Dwellings or other structures located therein (collectively referred to herein as "alteration" or "alterations") pursuant to this Section, Section 8, and the Act may be accomplished only in accordance with the following conditions

i. No Unit may be altered if thereafter the Dwelling located therein, or any other Dwelling affected by the alteration, would no longer be habitable or practicably usable for its intended purpose or would violate any law, code or ordinance of any governmental authority having jurisdiction over the Property.

ii. No alteration may be made which adversely affects the structural or functional integrity of any building system or the structural support or weather-tight integrity of any portion of any building or other structure.

ARTICLE XVII **AMENDMENTS**

This Declaration may be amended by the consent of (i) Owners of Units to which are allocated at least sixty-seven percent (67%) of the votes in the Association, (ii) the percentage of Eligible Mortgagees (based upon one vote per first mortgage owned) required by Section 18 as to matters prescribed by said Section and (iii) the consent of Declarant to certain amendments as provided in this Declaration. Consent of the Owners may be obtained in writing or at a meeting of the Association duly held in accordance with the By-Laws. Consents of Eligible Mortgagees and the Declarant shall be in writing. Any amendment shall be subject to any greater requirements imposed by the Act. The Amendment shall be effective when recorded as provided in the Act. An affidavit by the Secretary of the Association as to the outcome of the vote, or the execution of the foregoing agreements or consents, shall be adequate evidence thereof for all purposes, including without limitation, the recording of the amendment.

ARTICLE XVIII **RIGHTS OF ELIGIBLE MORTGAGEES**

Notwithstanding anything to the contrary in the Governing Documents, and subject to any greater requirements of the Act or other laws, Eligible Mortgagees shall have the following rights and protections

18.1 Consent to Certain Amendments. The written consent of Eligible Mortgagees representing at least fifty-one percent (51%) of the Units that are subject to first mortgages held by Eligible Mortgagees (based upon one vote per first mortgage owned) shall be required for any amendment to the Governing Documents which causes any change in the following: (i) voting rights, (ii) assessments, assessment liens, or priority of assessment liens, (iii) reserves for maintenance, repair and replacement of Common Elements, (iv) responsibility for maintenance and repairs, (v) reallocation of interest in the Common Elements or Limited Common Elements, or rights to their use, (vi) redefinition of any Unit boundaries, (vii) convertibility of Units into Common Elements or vice versa, (viii) expansion or contraction of the Property or the addition, annexation or withdrawal of property to or from the Property; (ix) insurance or fidelity bonds, (x) leasing of Units, (xi) imposition of any restrictions on an Owner's right to sell or transfer his or her Unit, (xii) a decision by the Association to establish self management when professional management is in effect as required previously by the Governing Documents or an Eligible Mortgagee, (xiii) restoration or repair of the Property (after a hazard damage or partial condemnation) in a manner other than that specified in the Governing Documents, (xiv) any action to terminate the legal status of the common interest community after substantial destruction or condemnation occurs, or (xv) any provisions that expressly benefit Eligible Mortgagees, or insurers or guarantors of mortgages

18.2 Consent to Certain Actions The written consent of Eligible Mortgagees representing at least sixty-seven percent (67%) of the Units that are subject to first mortgages held by Eligible Mortgagees (based upon one vote per first mortgage owned) shall be required to (i) abandon or terminate the common interest community, (ii) change the allocations of voting rights, Common Expense obligations or interest in the Common Elements, (iii) partition or subdivide a Unit except as permitted by statute, (iv) abandon, partition, subdivide, encumber or sell the Common Elements, or (v) use hazard insurance proceeds for other than the repair, replacement or reconstruction of the Property, except as otherwise provided by law

18.3 Consent to Subdivision No Unit may be partitioned or subdivided without the prior written approval of the Owner and Eligible Mortgagee thereof, and the Association

18.4 No Right of First Refusal. The right of an Owner to sell, transfer or otherwise convey his or her Unit shall not be subject to any right of first refusal or similar restrictions

18.5 Priority of Lien. Any holder of a first mortgage on a Unit or any purchaser of a first mortgage at a foreclosure sale, that comes into possession of a Unit by foreclosure of the first mortgage or by deed or assignment in lieu of foreclosure, takes the Unit free of any claims for unpaid assessments or any other charges or liens imposed against the Unit by the Association which have accrued against such Unit prior to the acquisition of possession of the Unit by said first mortgage holder or purchaser, (i) except as provided in Section 6 9 and the Act and (ii) except that any unreimbursed assessments or charges may be reallocated among all Units in accordance with their interests in the Common Elements

18.6 Priority of Taxes and Other Charges All taxes, assessments and charges which may become liens prior to the first mortgage under state law shall relate only to the individual Units and not to the Property as a whole

18.7 Priority for Condemnation Awards No provision of the Governing Documents shall give an Owner, or any other party, priority over any rights of the Eligible Mortgagee of the Unit pursuant to its mortgage in the case of a distribution to such Owner of condemnation awards for losses to or a taking of the Unit and/or the Common Elements. The Association shall give written notice to all Eligible Mortgagees of any condemnation or eminent domain proceeding affecting the Property promptly upon receipt of notice from the condemning authority

18.8 Requirements for Management Agreements The term of any agreement for professional management of the Property may not exceed two (2) years. Any such agreement must provide at a minimum for termination without penalty or termination fee by either party, (i) with cause upon thirty (30) days prior written notice, and (ii) without cause upon ninety (90) days prior written notice

18.9 Access to Books and Records/Audit. Eligible Mortgagees shall have the right to examine the books and records of the Association upon reasonable notice during normal business hours, and to receive free of charge, upon written request, copies of the Association's annual reports and other financial statements. Financial statements, including those which are audited, shall be available within one hundred twenty (120) days at the end of the Association's fiscal year

18.10 Notice Requirements Upon written request to the Association, identifying the name and address of the holder, insurer or guarantor or a mortgage on a Unit, and the Unit number or address, the holder, insurer or guarantor shall be entitled to timely written notice of.

- a. a condemnation loss or any casualty loss which affects a material portion of the Property or the Unit securing the mortgage;
- b. a 60-day delinquency in the payment of assessments or charges owed by the Owner of a Unit on which it holds a mortgage,
- c. a lapse, cancellation or material modification of any insurance policy maintained by the Association; and
- d. a proposed action which requires the consent of a specified percentage of Eligible Mortgagees.

ARTICLE XIX **MISCELLANEOUS**

19.1 Severability If any term, covenant, or provision of this instrument or any exhibit attached hereto is held to be invalid or unenforceable for any reason whatsoever, such determination shall not be deemed to alter, affect or impair in any manner whatsoever any other portion of this instrument or exhibits.

19.2 Construction Where applicable the masculine gender of any word used herein shall mean the feminine or neutral gender, or vice versa, and the singular of any word used herein shall mean the plural, or vice versa. References to the Act, or any section thereof, shall be

deemed to include any statutes amending or replacing the Act, and the comparable sections thereof.

19.3 Tender of Claims. In the event that any incident occurs which could reasonably give rise to a demand by the Association against Declarant for indemnification pursuant to the Act, the Association shall promptly tender the defense of the action to its insurance carrier, and give Declarant written notice of such tender, the specific nature of the action and an opportunity to defend against the action

19.4 Notice. Unless specifically provided otherwise in the Governing Documents or the Act, all notices required to be given by or to the Association, the Board of Directors, the Association officers or the Owners or Occupants shall be in writing and shall be effective upon hand delivery, or mailing if properly addressed with postage prepaid and deposited in the United States mail; except that registrations pursuant to Section 2.2 of the By-Laws shall be effective upon receipt by the Association.

19.5 Conflicts Among Documents. In the event of any conflict among the provisions of the Act, this Declaration, the By-Laws, or any Rules or Regulations approved by the Association, the Act shall control. As among this Declaration, the By-Laws and Rules and Regulations, this Declaration shall control, and as between the By-Laws and the Rules and Regulations, the By-Laws shall control.

19.6 Variances. The restrictions applicable to the Property as specified in Section 7 of this Declaration are intended for the benefit of all Owners. Declarant, however, acknowledges that exceptional conditions may create peculiar and practical difficulties mitigating against the strict enforcement of a provision contained in Section 7. In the event an Owner believes that such exceptional conditions create a hardship or special situation, an application for variance may be made by an Owner through the Board in accordance with this Declaration. An application for variance shall state on the application the reasons for allowing the variance, including (i) there are special circumstances or conditions such that the strict application of a provision of this Declaration would deprive the Owner of the reasonable use of the Owner's Unit; (ii) the variances are necessary for the preservation and enjoyment of a substantial property right of the Owner, (iii) the granting of the variance will not be detrimental to the public welfare or injurious to other Owners or Units subject to this Declaration, and (iv) the issuance of the variance will not have an adverse effect upon the health, welfare and safety of the Owners benefited by this Declaration. In considering a request for a variance from the strict application of Section 7 of this Declaration, the Board shall make a finding showing that all of the foregoing conditions exist and the Board may impose any reasonable condition in the granting of such variance in order to protect other Units and Owners

IN WITNESS WHEREOF, the undersigned has executed this instrument the day and year first set forth in accordance with the requirements of the Act.

Shade Tree Construction, Inc.
a Minnesota corporation

By. 
Mark Strandlund
Its President

STATE OF MINNESOTA)
) ss
COUNTY OF Anoka)

The foregoing instrument was acknowledged before me this 23rd day of May, 2003, by Mark Strandlund, the President of Shade Tree Construction, Inc , a Minnesota corporation, on behalf of the corporation



Notary Public

THIS INSTRUMENT DRAFTED BY

HINSHAW & CULBERTSON
3100 Campbell Mithun Tower
222 South Ninth Street
Minneapolis, MN 55402
(612) 333-3434

EXHIBIT A

CIC NO. #140

LEGAL DESCRIPTION

Lots 22 through 35 inclusive, Block 5, The Ponds of Ramsey

Lots 7 through 23, inclusive, Block 6, The Ponds of Ramsey

Lots 1 through 16, inclusive, Block 7, The Ponds of Ramsey

Lots 1 through 44, inclusive, Block 8, The Ponds of Ramsey

EXHIBIT B

CIC NO. 140

LEGAL DESCRIPTION

Common Elements

Lot 21, Block 5, The Ponds of Ramsey

Lot 6, Block 6, The Ponds of Ramsey

Lot 17, Block 7, The Ponds of Ramsey

Lot 45, Block 8, The Ponds of Ramsey

ABSTRACT

Receipt #	68626/39.00	<input type="checkbox"/> Incorrect/No Reference #
Date/Time	5/30 / 10:30	<input type="checkbox"/> Non-standard Document
Document Order	1 of 1	<input type="checkbox"/> Certified Copy/
PINs	83	32 pages
Recordability	88	
Filing Fees	\$ 20.00	<input type="checkbox"/> Tax Lien/Release
Copy Additional Pg Fees	\$ 19.00	<input type="checkbox"/> Transfer
Well Cert Fees	\$	<input type="checkbox"/> Division
<input type="checkbox"/> Incomplete Form		<input type="checkbox"/> Status
<input type="checkbox"/> Missing Attachment		<input type="checkbox"/> New legal Description
<input type="checkbox"/> No Legal Description		<input type="checkbox"/> GAC
<input type="checkbox"/> Non-existent Legal Description		<input type="checkbox"/> Deferred Specials
<input type="checkbox"/> Part(s) Illegible		<input checked="" type="checkbox"/> No Change

DOCUMENT NO 1805908.0 ABSTRACT
ANOKA COUNTY MINNESOTA

I HEREBY CERTIFY THAT THE WITHIN INSTRUMENT WAS FILED IN THIS OFFICE
FOR RECORD ON **MAY 30 2003**
AT **10:30 AM** AND WAS DULY RECORDED
FEES AND TAXES IN THE AMOUNT OF **\$39.00** PAID
2003068626

RECEIPT NO

MAUREEN J DEVINE
ANOKA COUNTY PROPERTY TAX ADMINISTRATOR/RECORDER/REGISTRAR OF TITLES
SLZ

BY _____
DEPUTY PROPERTY TAX ADMINISTRATOR/RECORDER/REGISTRAR OF TITLES