



Declaration For New CIC  
~~THIS DOCUMENT NUMBER REPRESENTS A PLAT~~

ALL PLATS ARE MAINTAINED ON A SEPARATE MICROFICHE IN A SEPARATE SECTION RESERVED FOR PLATS. FULL SIZE COPIES OF PLATS ARE STILL AVAILABLE FOR VIEWING.

MUNICIPALITY: Fridley ~~CERTIFIED~~ BY: [Signature] ON 12-30-96

MAP # 1825 PLAT BOOK: — OF — PAGE —

DOC. DATE: 12-16-96 NO. OF PAGES: — TRACT BOOK: — PAGE —

PLAT SHORT NAME: CIC NO 23 Christenson Cross

LONG NAME: By Declaration

A/T	PARENT PINS	<del>RES?</del>	RES?	GRANTORS (Fees, C/Ps, Mortgagees)	Marital Status
A#T	14-30-24-32-0061 thru 0121				

FILED BY: \_\_\_\_\_ PHONE: \_\_\_\_\_

TAXPAYER NAME: \_\_\_\_\_

ADDRESS: \_\_\_\_\_

CITY: \_\_\_\_\_ STATE: \_\_\_\_\_ ZIP: \_\_\_\_\_

**NEW PARCELS**

LOT	BLOCK	LOT	BLOCK	LOT	BLOCK

DELO & CURRENT TAXES ARE PAID: INITIALS: \_\_\_\_\_ DATE: \_\_\_\_\_

DIV. NO.: \_\_\_\_\_

DIV. FEE: \$ \_\_\_\_\_

## COMMON INTEREST COMMUNITY NUMBER 23

## A Planned Community

## THE VILLAGE HOMES OF CHRISTENSON CROSSING

## DECLARATION

THIS DECLARATION, made on this 16th day of December, 1996, by The Rottlund Company, Inc., a Minnesota corporation, hereinafter referred to as "Declarant", pursuant to the provisions of the Minnesota Common Interest Ownership Act, Minnesota Statutes Sections 515B.1-101 to 515B.4-118, (hereinafter referred to as the "Act"), as amended.

WHEREAS, Declarant is the owner of certain property in the City of Fridley, County of Anoka, State of Minnesota, which is more particularly described as:

Lots 1 through 55, inclusive, including Lots 1A and 6A, Block 1, Christenson Crossing, according to the plat on file and of record in the Office of the County Recorder, Anoka County, Minnesota, and the Office of the Registrar of Titles, Anoka County, Minnesota.

(the "Property" or "Properties"), which Declarant intends to develop for residential uses; and

WHEREAS, Declarant desires that all of the Property shall be subject to certain uniform covenants, conditions and restrictions; and

NOW, THEREFORE, Declarant hereby declares that all of the Properties described above shall be held, sold, and conveyed subject to the Act and the following easements, restrictions, covenants and conditions, which are for the purpose of protecting the value and desirability of, and which shall run with, the real property and be binding on all parties having any right, title or interest in the described Properties or any part thereof, their heirs, successors and assigns, and shall inure to the benefit of each owner thereof.

This common interest community is a planned community and is not subject to a master association.

ARTICLE I.  
DEFINITIONS

Section 1. "Association" shall mean and refer to The Village Homes of Christenson Crossing Association, Inc., a

corporation formed under Chapter 317A, Minnesota Statutes, its successors and assigns.

Section 2. "Owner" shall mean and refer to the record owner, whether one or more persons or entities, of a fee simple title to any Lot which is a part of the Properties, including contract sellers, but excluding those having such interest merely as security for the performance of an obligation. Where any such Lot is being sold by the fee owner to a contract vendee who is entitled to possession of the Lot, the contract vendee shall be considered to be the owner of the Lot if: (a) the rights of the contract vendor hereunder are delegated to the vendee under such contract for deed; and (b) the vendee shall furnish proof of such delegation to the Association.

Section 3. "Properties" shall mean and refer to that certain real property hereinbefore described, and such additions thereto as may hereafter be brought within the jurisdiction of the Association.

Section 4. "Lot" shall mean and refer to any separately identified plot of land shown upon any recorded subdivision map or plat of the Properties which is intended to be sold to the ultimate buyer as a separate property; provided, however that Lots 6 and 6A, Block 1, Christenson Crossing shall constitute a single "Lot". Where appropriate, reference to "Lot" shall include all structures located upon a Lot. The boundaries of each Lot and the unit identifier of each Lot shall be as shown on the Plat.

Section 5. "Declarant" shall mean and refer to The Rottlund Company, Inc., a Minnesota corporation, its successors and assigns.

Section 6. "Common Elements" shall mean and refer to the following described real property in Anoka County, Minnesota:

Lots 1 and 1A, Block 1, Christenson Crossing, according to the plat on file and of record in the Office of the County Recorder, Anoka County, Minnesota, and the Office of the Registrar of Titles, Anoka County, Minnesota.

Section 7. "Eligible Mortgagee" shall mean any person owning a mortgage on any Lot, which mortgage is first in priority to any other mortgages that encumber such Lot, and which has requested the Association, in writing, to notify it regarding any proposed action which requires approval by a specified percentage of Eligible Mortgagees.

Section 8. "Act" shall mean the Minnesota Common Interest Ownership Act, Minn Stat. Sec. 515B.1-101, et seq.

Section 9. "Plat" shall mean the plat of Christenson Crossing recorded in the office of the County Recorder, Anoka County, Minnesota and in the Office of the Registrar of Titles, Anoka County, Minnesota.

Section 10. Definitions Incorporated. Except as otherwise specified in this Declaration, the terms used in this Declaration which are defined in the Act shall have the same meaning as they have in the Act.

Section 11. Statutory Requirements. In accordance with the requirements of Section 515B.2-105 of the Act, the Declarant hereby states the following:

- (a) The number of the Common Interest Community created hereby is the number set forth on the first page of this Declaration.
- (b) The name of the Association is The Village Homes of Christenson Crossing Association, Inc. The Association has been incorporated pursuant to the provisions of Minnesota Statutes Chapter 317A.
- (c) The common interest community created hereby is a planned community. It is not subject to a master association.
- (d) The legal description of the Property included within the common interest community created hereby (including all appurtenant easements) is set forth on the attached Exhibit A.
- (e) The description of the boundaries of each Lot created by this Declaration, including the unit identifier number for each Lot, is set forth on the Plat, which plat has been filed for record with the office of the Anoka County Recorder and in the office of the Anoka County Registrar of Titles and is hereby incorporated herein by reference.
- (f) The allocated interests are assigned equally to each Lot, subject to the provisions of this Declaration. Each Lot shall have one vote in the affairs of the Association. Except as provided in Article III, Section 6 (relating to the Alternative Assessment Program) or as permitted in the Act, each Lot shall share the Common Expenses equally.
- (g) The common interest community created hereby shall consist of 54 Lots, all of which shall be restricted to residential use.

- (h) No additional units may be created by the subdivision or conversion of Lots.
- (i) The use restrictions to which the Lots are subject are located in Articles VI and VII hereof. There is no restriction on the sale price of a unit. The amount to be received upon the condemnation or termination of the common interest community is set forth in Article XIII, Section 10 and Article XIII, Section 11, respectively. Provisions relating to casualty insurance are set forth in Article X, Section 2.
- (j) Time shares are not permitted.
- (k) Matters relating to Special Declarant Rights are contained in Article XII hereof. Matters relating to the use of the Common Elements are contained in Article VII hereof. Matters relating to the care and maintenance of the Common Elements are contained in Article IV hereof. Matters relating to assessments for Common Expenses are contained in Article III hereof. Matters relating to Limited Common Elements are contained in Article XIII, Section 9.

ARTICLE II.  
MEMBERSHIP AND VOTING RIGHTS

Section 1. Every Owner shall be a member of the Association. Membership shall be appurtenant to and may not be separated from ownership of any Lot. When more than one person is an Owner of a Lot, all such persons shall be members of the Association, but multiple ownership of a Lot shall not increase the voting rights allocated to such Lot nor authorize the division of the voting rights.

Section 2. Voting rights and Common Expense obligations are allocated equally among the Lots; except that special allocations of Common Expenses shall be permitted as provided in this Declaration and except for the alternative expense allocation as provided in this Declaration.

Section 3. The ownership of a Lot shall include the voting rights and Common Expense obligations described in Article II, Section 2. Said rights, obligations and interest, and the title to the Lots, shall not be separated or conveyed separately. The allocation of the rights, obligations and interests described in this Section may not be changed except in accordance with this Declaration, the Bylaws and the Act.

Section 4. The Owner, or some natural person designated as proxy on behalf of the Owner, and who need not be an owner,

may cast the vote allocated to such Lot at meetings of the Association; provided, that if there are multiple Owners of a Lot, only the Owner or other person designated pursuant to the provisions of the Bylaws may cast such vote. The voting rights of Owners are more specifically described in the Bylaws.

ARTICLE III.

COVENANT FOR COMMON EXPENSE  
AND INSURANCE PREMIUM ASSESSMENTS;

Section 1. Creation of the Lien and Personal Obligation of Assessments. The Declarant, for each Lot owned within the Properties, hereby covenants, and each Owner of any Lot by acceptance of a deed or contract for deed therefor, whether or not it shall be so expressed in such deed or contract, is deemed to covenant and agree to pay to the Association:

- (a) general annual assessments or charges;
  - (i) a common expense or portion thereof benefiting fewer than all of the Lots may be assessed exclusively against the Lots benefitted, on basis of (A) equality, (B) square footage of the area being maintained, repaired or replaced, or (C) the actual cost incurred with respect to each Lot.
- (b) assessments for master insurance premiums, if any, which may be assessed in proportion to value, risk or coverage.
- (c) special assessments for capital improvements, such assessments to be established and collected as hereinafter provided.
- (d) assessments levied under Section 515B.3-116 of the Act to pay a judgment against the Association, which assessments may be levied only against the Lots existing at the time the judgment was entered, in proportion to their Common Expense liabilities.
- (e) assessments for fees, charges, late charges, fines and interest.
- (f) If any damage to the Common Elements or another Lot is caused by the act or omission of any Owner, the guests of an Owner or the occupant of any Lot, assessments for the costs of repairing the damage may be assessed exclusively against the Owner's Lot to the extent not covered by insurance.

The assessments, together with interest, costs and reasonable attorney's fees, shall be a charge on the Lot and shall be a continuing lien upon the property against which each such assessment is made. Each such assessment, together with interest, costs and reasonable attorney's fees, shall also be the personal obligation of the person who was the Owner of such property at the time when the assessment fell due and if more than one person was an Owner then such obligation shall be joint and several. The personal obligation for delinquent assessments shall not pass to the Owner's successors in title unless expressly assumed by them.

Section 2. Purpose of Assessments. The assessments levied by the Association shall be used exclusively to promote the purposes of the Association as set forth in Article IV.

Section 3. Limitation on Assessments. Until January 1 of the year immediately following the conveyance of the first Lot to an Owner, the maximum annual general assessment to an Owner and the Owner's Lot shall be \$1,020.00 per Lot.

- (a) From and after January 1 of the year immediately following the conveyance of the first Lot to an Owner, the maximum annual general assessment may be increased each year not more than 10% above the maximum assessment for the previous year without a vote of the membership of the Association.
- (b) From and after January 1 of the year immediately following the conveyance of the first Lot to an Owner, the maximum annual general assessment may be increased by 10% or more by a vote of Owners representing 2/3 of the Lots who are voting in person or by proxy, at a meeting duly called for this purpose.
- (c) The Board of Directors of the Association may fix the annual general assessment at an amount not in excess of the maximum, and the Board of Directors of the Association may modify the annual assessment upward or downward from time to time, but in no event upward beyond the maximum permitted by this Section. Written notice of any modification of the annual general assessment shall be sent to every Owner subject hereto.

Section 4. Special Assessment for Capital Improvements. In addition to the annual general assessments, the Association may levy, in any assessment year, a special assessment applicable to that year only for the purpose of defraying, in whole or in part, the cost of any construction, reconstruction, repair or replacement of a capital improvement upon the Common Elements, including fixtures and personal property related thereto, provided that any such assessment shall have the assent of Owners



representing 2/3 of the Lots who are voting in person or by proxy at a meeting duly called for this purpose.

Section 5. Notice and Quorum for any Action Authorized Under Sections 3 and 4. Written notice of any meeting called for the purpose of taking any action authorized under Sections 3 and 4 shall be sent to all Owners not less than 21 days nor more than 30 days in advance of an annual meeting or not less than 7 days nor more than 30 days in advance of a special meeting. At the first such meeting called, the presence of members or of proxies entitled to cast more than 50% of all the votes shall constitute a quorum. If the required quorum is not present, another meeting may be called subject to the same notice requirement, and the required quorum at the subsequent meeting shall be 1/2 of the required quorum of the preceding meeting. No such subsequent meeting shall be held more than 60 days following the preceding meeting.

Section 6. Uniform Rate of Assessment; Alternative Assessment Program. Both general annual and special assessments on all Lots must be fixed at a uniform rate, except vacant Lots which shall be assessed at 25% of the established assessment rate, except:

- (a) no assessments shall be made against any Lot which is a parcel of real estate which is not intended for separate ownership or occupancy.
- (b) any Lot owned by Declarant and which is not exempt from assessment by Section 6(a) shall be assessed at 25% of the established assessment rate, until such time as a certificate of occupancy is issued by the City of Fridley, Minnesota.
- (c) This alternative assessment program shall have no effect on the level of services for items set forth in the Association's budget.

Annual and/or special assessments may be collected on a monthly basis at the discretion of the Association.

Section 7. Date of Commencement of Assessments; Due Dates. The general annual assessment provided for herein shall commence as to all Lots on the first day of the month following the conveyance by the Declarant of a Lot. Notwithstanding the foregoing to the contrary, any Lot owned by Declarant shall be assessed pursuant to the alternative assessment program set forth in Section 6.

The first general annual assessment shall be adjusted according to the number of months remaining in the calendar year. The Board of Directors of the Association shall fix the amount of

such assessments against each Lot at least thirty (30) days in advance of each annual assessment period. Written notice of such assessments shall be sent to every Owner subject thereto. The due dates shall be established by the Board of Directors of the Association. The Association shall, upon demand, and for a reasonable charge, furnish a certificate signed by an authorized representative of the Association setting forth whether the assessments on a specified Lot have been paid. A properly executed certificate of the Association as to the status of assessments on a Lot is binding upon the Association as of the date of its issuance.

Section 8. Effect of Nonpayment of Assessments; Remedies of the Association. Any assessment to any Member not paid within 30 days after the due date shall bear interest from the due date at a rate of 8% per annum. The Association may bring an action at law against the Owner personally obligated to pay the same or foreclose the Lien against the Property. Such Lien may be foreclosed in the same manner as a mortgage pursuant to Minnesota Statutes, Chapters 580, 581 or 582, as amended, and the Association shall be entitled to recover interest at the rate of 8% per annum and its costs, expenses and disbursements, including reasonable attorney's fees, incurred in such foreclosure. No Owner may waive or otherwise escape liability for the assessments provided for herein by non-use of the Common Elements or abandonment of the Owner's Lot. If the Association has provided for monthly installment payments of assessments, the Association may accelerate and the Owner shall pay the unpaid balance of an annual installment if the Owner has failed to pay any monthly installment within 30 days after the due date of a monthly installment. To the extent permissible, the Association may deny services to any Member who is more than 30 days delinquent in the payment of any assessment or installment of an assessment.

Section 9. Subordination of the Lien to Mortgage. The lien of the assessments provided for herein shall be subordinate to the lien of any first mortgage, except as provided in Section 515B.3-116 of the Act. Sale or transfer of any Lot shall not affect the assessment lien. No sale or transfer shall relieve such Lot from liability for any assessments thereafter becoming due or from the lien thereof.

#### ARTICLE IV. DUTIES OF ASSOCIATION

Section 1. General Duties. In addition to maintenance upon the private streets and driveways, including the maintenance of water and sewer services from any public mains, the Association shall provide for maintenance upon the Lots and Common Elements as follows: lawn care and irrigation on Common Elements, including maintenance of proper slopes leading to detention

ponds, whether located within or without the Property, and maintenance of trees, shrubs, entry plantings on Common Elements and plantings along the foundations of structures on the Lots as installed by Declarant, light fixtures or light standards along private roads, and exterior painting of dwellings.

Section 2. Fence Easement. The Association shall maintain, repair and replace the landscaping, retaining wall and fence located on the Fence Easement described in Exhibit B attached hereto. b

Section 3. Fire Hydrants. The Association shall flush fire hydrants located within the Property in accordance with the policies of the City of Fridley or shall permit the Public Works Department of the City of Fridley to perform such flushing. The Association shall provide that all fire hydrants are visible and are kept free of snow or other obstructions.

Section 4. Other Duties. - The Association shall:

- (a) repair, maintain and replace the paved trailways as constructed by Declarant within the Trailways as Described in Exhibit C attached hereto. c
- (b) repair, maintain, replace and operate the storm water system, including the pond located within Lot 1, Block 1, Christenson Crossing, Anoka County, Minnesota.
- (c) remove debris and snow from the sidewalk located on the Property along 3rd Street in the Plat, unless such services are generally provided by the City of Fridley, Minnesota.
- (d) repair, maintain and replace any entrance monuments as originally constructed by Declarant for The Village Homes of Christenson Crossing.

Section 5. Miscellaneous. In the event that the need for maintenance or repair is caused through the willful or negligent act of the Owner, his family, or guests, invitee, or lessees, the cost of such maintenance or repairs shall be added to and become a part of the assessment to which such Lot is subject.

The Association shall enforce the covenants, conditions and restrictions set forth herein and any amendments hereto and any rules and regulations adopted by the Association. The Association may provide for trash removal services in accordance with the provisions of Article IX hereof and shall provide insurance as required in this Declaration.

The Association shall undertake, at its discretion, such further duties as determined by the Board of Directors.

ARTICLE IV-A  
MAINTENANCE BY CITY

Section 1. Maintenance by City. In the event that the Association fails to maintain or repair Common Elements or the Common Element Amenities, the City of Fridley, a municipal subdivision under the laws of the State of Minnesota, (the "City"), shall have the right to repair and maintain such Common Elements or Amenities. The Association shall be deemed to have failed to maintain or repair the Common Elements or Amenities only if the City has given written notice to the Association of the maintenance or repairs which has not been performed and the Association fails to perform such maintenance or repairs within 30 days after receipt of such notice, or if the Association fails to commence performance of such maintenance or repairs during such 30-day period if such maintenance or repairs cannot, by their nature, be reasonably completed within 30 days.

Section 2. Easement for Maintenance. The City is hereby granted an easement on, over, across and under the Common Elements for purposes of performing any maintenance or repairs to the Common Elements and the Amenities pursuant to this Article.

Section 3. Assessment. If the City performs maintenance or repairs pursuant to this Article, the City may assess the Common Elements for the costs of said repairs and maintenance. The Association shall then levy a special assessment against the Lots, or shall use current reserves, to defray the total amount of the assessment by the City. Said special assessment or use of reserves shall be determined by the Board of Directors and shall not require the consent of Lot Owners or mortgagees.

ARTICLE V.  
(Intentionally Omitted)

ARTICLE VI.  
ARCHITECTURAL CONTROL

Section 1. Structures. No building, fence, wall, deck or other structure shall be commenced, erected or maintained upon the Properties, nor shall any exterior addition to, or change or alteration therein be made until the plans and specifications showing the nature, kind, shape, height, materials, and location of the same shall have been submitted to and approved in writing as to harmony of external design and location in relation to surrounding structures and topography by the Board of Directors of the Association, or by an architectural committee composed of three (3) or more representatives appointed by the Board.

Section 2. Approval. In the event said Board of Directors, or its designated architectural committee, fails to approve or disapprove such design and location, or planting, within 30 days after said plans and specifications have been submitted to it, approval will not be required and this Article will be deemed to have been fully complied with.

ARTICLE VII.

ADDITIONAL RESTRICTIONS; RULES AND REGULATIONS

Section 1. Additional Restrictions.

- (a) No lot shall be used except for residential purposes, except that Declarant shall be entitled to maintain model homes and other sales facilities upon the Lots.
- (b) No sign of any kind shall be displayed, to the public view on any lot except one professional sign of not more than one (1) square foot and one sign of not more than five (5) square feet advertising the property for sale, except that Declarant shall be permitted to erect and maintain upon the Property such signs as it deems appropriate to advertising the Property until the Declarant conveys the last Lot.
- (c) The Board of Directors, at its discretion, may adopt rules and regulations prohibiting or permitting the keeping of animals on the Lots. No fenced dog runs or dog houses shall be allowed on any Lot.
- (d) No Lot shall be used or maintained as a dumping ground for rubbish, trash, garbage or other waste, including pet or household waste. Garbage, rubbish and trash shall not be kept on said premises except in sanitary containers. All incinerators or other equipment used or kept for the storage or disposal of such material shall be kept in a clean and sanitary condition.
- (e) No noxious or offensive activity shall be carried on upon any Lot nor shall anything be done thereon which may be or may become an annoyance or nuisance to the neighborhood.
- (f) No structure of a temporary character, trailer, basement, tent, shack, garage, barn or other building shall be used on any Lot at any time as a residence, either temporarily or permanently.
- (g) No trailers, boats, buses, motor homes, campers, snowmobiles or other types of recreational vehicles shall be parked on any Lot for more than 48 consecutive

hours unless such vehicle is parked within a garage or storage shed located on such Lot; provided that the Board of Directors of the Association may grant permits to park such vehicles on Lots for limited periods of time not to exceed fourteen (14) days in any twelve-month (12) period. No such vehicles shall be parked on any Common Element.

- (h) No aerial, antenna or satellite dish which is (i) over four feet in height, as measured from the point on any structure to which the aerial, antenna or satellite dish is affixed; (ii) more than four square feet in size; (iii) not attached to a dwelling unit, or (iv) of a color not approved by the Association, shall be permitted on any Lot.
- (i) No abandoned motor vehicle as defined in Minnesota Statutes Section 168B.02, subdivision 2, as amended from time to time, shall be permitted to remain upon the streets or driveways or on any Lot or parking area. The Association shall have the right to remove any such vehicle at any time, and assess the costs of such removal against the Lot which is owned or occupied by the person in control or possession of such vehicle.
- (j) Except as herein permitted for Declarant, no business, trade, occupation or profession of any kind, whether carried on for profit or otherwise, shall be conducted, maintained or permitted on any Lot, except: (i) an Owner or occupant residing in a Lot may keep and maintain his or her business or professional records in such Lot and handle matters relating thereto by telephone or correspondence therefrom, provided that such uses are incidental to the residential use of the Lot; and (ii) the Association may maintain offices on the Property for management and related purposes.
- (k) No Lot may be leased for transient or hotel purposes. Any lease of any lot shall be in writing which shall be expressly subject to the Act, this Declaration and any Rules and Regulations adopted by the Association and which provide that any violation of the Act, this Declaration and any Rules and Regulations shall be a default under the lease. No time shares shall be created with respect to any Lot.
- (l) No parking shall be permitted on private streets located within the Property in accordance with any "No Parking" signs posted by the Association as requested by the Fire Department of the City of Fridley.

- (m) No Owner shall own more than two (2) Lots to be used for rental purposes.
- (n) Any requests to enclose patios or decks or to make any additions to Lots shall be subject to approval of the Architectural Committee as herein provided, the approval of the City of Fridley and shall comply with all requirements of any regulatory authority.

Section 2. Rules and Regulations. The Association may adopt, amend and revoke rules and regulations not inconsistent with the Articles of Incorporation, this Declaration or the Bylaws of the Association, as follows:

- (a) regulating the use of the Common Elements;
- (b) regulating the use of Lots and the conduct of living unit occupants which may jeopardize the health, safety and welfare of other occupants, which involves noise or other disturbing activity, or which may damage the Common Elements or other living units;
- (c) regulating or prohibiting animals;
- (d) regulating changes in the appearance of the Common Elements and conduct which may damage the common interest community;
- (e) regulating the exterior appearance of the common interest community, including, by way of illustration and not limitation, balconies and patios, window treatments, and signs and other displays, regardless of whether inside a living unit;
- (f) implementing the Articles of Incorporation, this Declaration or the Bylaws of the Association; and
- (g) other rules facilitating the operation of the common interest community.

After notice and an opportunity to be heard, the Association may impose reasonable sanctions, including the levying of reasonable fines and reasonable restrictions on services and use of Common Elements, for violations of the Declaration, Bylaws and Rules and Regulations of the Association.

ARTICLE VIII.  
EASEMENTS

Section 1. General. In addition to the easements, covenants, restrictions and conditions herein, all Lots shall be subject to easements and covenants hereinafter specifically described for the benefit of the Properties or for the limited benefit of specified adjoining Lots, all as more fully set forth hereinafter in this Article. Within such easements, no structure, planting or other material shall be placed or permitted to remain which may damage or interfere with the installation and maintenance of any utilities or trails or which may change the flow or drainage channels within the easements or which may obstruct, retard or change the flow of water through drainage easements. The easement area of each Lot and all improvements therein shall be maintained continuously by the Owner of the Lot, except for improvements which are the responsibility of a public authority or utility company.

Section 2. Utility Easements. All Lots and Common Elements are hereby subjected to easements for the installation and maintenance of utilities, including gas, telephone, electric and cable TV. The Association or its proper representatives shall have the right of free access to any Lot or living unit for the purpose of maintaining any utility service to any Lot on the Properties. In addition, each Lot over which a utility is in fact installed or constructed as part of the original utility system shall be subject to an easement for utility purposes over the portion of the Lot upon which such utility service is constructed.

Section 3. Easements for Encroachment. In the event that any buildings or other structures originally constructed by the Declarant or constructed or erected thereafter on any Lot in accordance with the this document encroaches upon any other Lot, or, if any such encroachment shall hereafter arise because of settling or shifting of the building or other cause, an exclusive easement appurtenant to said encroaching Lot for such encroachment and the maintenance thereof shall exist.

Section 4. Easement for Maintenance. Declarant hereby grants an easement in favor of the Association over and across each Lot for the purposes of the Association performing its duties.

Section 5. Easement of Maintenance by Lot Owners. The Owner of each Lot is hereby granted an easement over the adjoining six feet of the Common Element or each adjoining buildable lot, or, if less, to the outside wall of any structure on the adjoining buildable Lot, for the purposes of repair and maintenance upon any structure on the Owner's Lot; provided, however, that the Owner shall be responsible to restore any landscaping, grade,



plantings or irrigation system located within the easement area which is damaged during the Owner's use of the easement area.

Section 6. Emergency Vehicles. Declarant hereby grants a perpetual, non-exclusive easement in favor of the City of Fridley, a municipal corporation under the laws of the State of Minnesota, on, over and across the Common Element for the purpose of ingress and egress for police, fire, rescue and other emergency calls, animal control, health and prospective inspection and to provide to the Owners other public services deemed necessary by the City of Fridley and for the purposes set forth herein.

Section 7. Trailway Easement. Declarant hereby grants a perpetual non-exclusive easement in favor of the City of Fridley, a municipal corporation under the laws of the State of Minnesota, on, over and across that portion of the Common Element described in Exhibit C attached hereto for purposes of passage by the public.

#### ARTICLE IX. TRASH REMOVAL

Section 1. Master Contract. The Association may contract with a single provider for the removal and disposal of garbage, trash and other solid waste from all Lots in accordance with this Declaration. Each Owner shall be obligated to purchase such services from the provider designated by the Association upon the terms, conditions and rates negotiated by the Association.

Section 2. Charges. Any charges imposed by the provider designated by the Association shall be paid by the Association and shall be included in the general assessments to Owners. In the event that any Owner requests any services not included within the basic/general charges of the provider, the Owner, upon written demand by the Association, shall reimburse the Association for any charges for such services, plus all related costs, including interest, attorney fees and administrative charges of the Association, and if not paid by Owner, such charges shall be a lien against the Lot. Any charge, lien or claim pursuant to this Article shall not be subject to any maximum increase in general assessments.

#### ARTICLE X. INSURANCE AND RECONSTRUCTION

Section 1. Liability Insurance; Fidelity Bonds. The Board of Directors of the Association, or its duly authorized agent, shall obtain a broad form of public liability insurance insuring the Association, with such limits of liabilities as the

Association shall determine to be necessary, against all acts, omissions to act and negligence of the Association, its employees and agents.

Section 2. Property Insurance. Each Owner shall obtain and maintain the Owner's own property and liability insurance coverages relating to the ownership of the Lot and any structures constructed thereon.

Section 3. Other Insurance. The Association shall procure and maintain the following additional insurance coverage:

- (a) Fidelity coverage against dishonest acts on the part of Directors, Managers, trustees, employees or volunteers responsible for handling funds collected and held for the benefit of the Owners. The fidelity bond or insurance shall name the Association as the named insured and shall be written in an amount which is in no event less than the amount required by the Act. An appropriate endorsement to the policy to cover any persons who serve without compensation shall be added if said policy would not otherwise cover volunteers.
- (b) A comprehensive policy of public liability insurance covering the Common Elements in an amount not less than one million dollars. Such insurance shall contain a "severability of insurance" endorsement which shall preclude the insurer from denying the claim of the Owner because of negligent acts of the Association or other owners. The policy shall include such additional coverages, endorsements or limits as may be required by regulations of the Federal Housing Administration, ("FHA"), or the Federal National Mortgage Association, ("FNMA"), as a precondition to their insuring, purchasing or financing a mortgage on a Lot.
- (c) Workers Compensation insurance as required by law.
- (d) Directors and officers liability insurance with such reasonable limits and coverages as the Board of Directors may determine from time to time.
- (e) Such other insurance as the Board of Directors may determine from time to time to be in the best interests of the Association and the Owners or as may be required by the Act.

Section 4. Deductibles. As to any deductibles under any insurance coverages obtained by the Association, the Board of Directors may:

- (a) pay the deductible as a general common expense;

- (b) assess the deductible amount against any Lots affected in a reasonable manner; or
- (c) assess the deductible against any Owner and the Owner's Lot if the loss was caused by the act or omission of the Owner, or the Owner's agents, employees, invitees, guests or any one occupying the Lot with the expressed or implied permission of the Owner.

ARTICLE XI.  
RIGHTS OF ELIGIBLE MORTGAGEES

Section 1. Consent to Certain Amendments. The written consent of eligible mortgagees representing at least fifty-one (51.0%) percent of the Lots that are subject to first mortgages held by Eligible Mortgagees, (based upon one vote per first mortgage owned), shall be required for any amendment to this Declaration, Articles of Incorporation or Bylaws of the Association which causes any change in the following:

- (a) voting rights;
- (b) increases in assessments that raise the previously assessed amount by more than 25%, assessment liens or priority of assessment liens;
- (c) reductions in reserves for maintenance, repair and replacement of Common Elements;
- (d) responsibility for maintenance and repairs;
- (e) reallocation of interests in the Common Elements or right to their use;
- (f) redefinition of any Lot boundaries;
- (g) convertability of Lots into Common Elements or vice versa;
- (h) expansion of the Property or the addition or withdrawal of property to or from the Property;
- (i) hazard or fidelity insurance requirements;
- (j) leasing of Lots;
- (k) imposition of any restrictions on the leasing of Lots;
- (l) restoration or repair of the Property, (after hazard damages or partial condemnation) in a manner other than that specified in this Declaration;

- (m) any action to terminate the legal status of the common interest community after substantial destruction or condemnation occurs; or
- (n) any provisions that expressly benefit mortgage holders, or insurers or guarantors of mortgages.

Notwithstanding the foregoing, implied approval of a proposed amendment shall be assumed when an Eligible Mortgagee fails to submit a response to any written proposal for an amendment within 30 days after it receives proper notice of the proposal, provided that the notice was delivered by certified mail with a return receipt.

Section 2. Consent to Certain Actions. The written consent of Eligible Mortgagees representing at least sixty-seven (67.0%) percent of the Lots that are subject to first mortgages, (based upon one vote per first mortgage owned) shall be required to abandon or terminate the common interest community, subject to any greater requirements contained in the Act.

Section 3. Consent to Subdivision. No Lot may be partitioned or subdivided without the prior written approval of the Owner, Eligible Mortgagee thereof, and the Association.

Section 4. No Right of First Refusal. The right of an Owner to sell, transfer or otherwise convey his Lot shall not be subject to any right of first refusal or similar restrictions.

Section 5. Priority of Lien. Any holder of a first mortgage on a Lot or any purchaser of a first mortgage at a foreclosure sale, that comes into possession of a Lot by foreclosure of the first mortgage or by deed or assignment in lieu of foreclosure, takes the Lot free of any claims for unpaid assessments or other charges or liens imposed against the Lot by the Association which have accrued against such Lot prior to acquisition of possession of the Lot by said first mortgage holder or purchaser;

- (a) except as provided in Article III, Section 9 and the Section 515B.3-116 of the Act; and
- (b) except that any unpaid assessments or charges with respect to the Lot may be reallocated among all Lots in accordance with their interests in Common Elements.

Section 6. Priority of Taxes and Other Charges. All taxes, assessments and charges which may become liens prior to the first mortgage under state law shall relate only to the individual Lots and not the Property as a whole.

Section 7. Priority for Condemnation Awards. No provisions of this Declaration or the Articles of Incorporation or Bylaws of

the Association shall give an owner, or any other party, priority over any rights of the Eligible Mortgagee of the Lot pursuant to its mortgage in the case of a distribution to such Owner of insurance proceeds or condemnation awards for losses to or a taking of the Lot and/or the Common Elements. The Association shall give written notice to all Eligible Mortgagees of any condemnation or eminent domain proceeding affecting the Property promptly upon receipt of notice from the condemning authority.

Section 8. Management Agreements. The term of any agreement for professional management of the Property may not exceed one (1) year. Any such agreement must provide at a minimum for termination without penalty or termination fee by either party

- (a) with cause upon thirty (30) days prior written notice; and
- (b) without cause, upon ninety (90) days prior written notice.

Section 9. Access to Books and Records. Eligible Mortgagees shall have the right to examine the books and records of the Association upon reasonable notice during normal business hours, and to receive free of charge, upon written request, copies of the Association's annual reports and other financial statements. Financial statements, including those which are audited, shall be available within one hundred twenty (120) days of the end of the Association's fiscal year. If a request is made by FNMA or any institutional guarantor or insurer of a mortgage loan against a Lot for an audit of the Association's financial statements, the Association shall cause an audit to be made and shall deliver a copy to the requesting party, subject to the Bylaws of the Association.

Section 10. Notice Requirements. Upon written request to the Association, identifying the names and address of the holder, insurer or guarantor of a mortgage on a Lot, and the Lot number or address, the holder, insurer or guarantor shall be entitled to timely written notice of:

- (a) a condemnation loss or any casualty loss which affects a material portion of the Lot securing the mortgage.
- (b) a 60-day delinquency in payment of assessments or charges owed by the Owner of a Lot on which it holds a mortgage.
- (c) a lapse, cancellation or material modification of any insurance policy maintained by the Association.
- (d) a proposed action which requires the consent of a specified percentage of Eligible Mortgagees.

ARTICLE XII.  
SPECIAL DECLARANT RIGHTS

Section 1. Period of Declarant Control. Notwithstanding anything in this Declaration or the Association Bylaws to the contrary, the Declarant shall have the right to control the management and affairs of the Association until the earlier of the following events:

- (a) 60 days after the conveyance of seventy-five percent of the Lots to Lot Owners other than the Declarant, or
- (b) five years from the date of the recording of this Declaration.

During this period of Declarant Control, the Declarant, subject to the Bylaws, shall have the sole right to appoint, remove and replace the officers and directors of the Association. Notwithstanding the foregoing, the Owners other than the Declarant shall have the right to nominate and elect not less than 33 1/3% of the directors at a meeting of the Owners which shall be held within 60 days following the conveyance by Declarant of 50% of the Lots authorized to be included in the Common Interest Community.

Section 2. Maintenance of Sales Offices. Notwithstanding anything herein to the contrary, so long as the Declarant owns an interest in a Lot, the Declarant may maintain advertising signs on any part of the Common Elements and sales offices, management offices and model units in any Lots or in or on any part of the Common Elements and such sales offices and model units may be relocated by Declarant from time to time. There shall be no limit on the number or location of such offices or model units.

Section 3. Easements in Favor of Declarant. Notwithstanding any provisions contained herein to the contrary, so long as construction and initial sale of Lots shall continue, Declarant shall have an easement over and across the Common Elements for the purpose of carrying out its sales activities and for the purpose of completing the construction on any Lots, including without limitation the right of vehicular ingress and egress, vehicular parking, material storage, and the maintenance of business offices, signs, model units, and sales offices, and Declarant shall have an easement for access to such facilities; provided, however, that Declarant shall promptly restore any damage to the Common Elements by reason of any construction incident to the foregoing. This Section may not be amended without the express written consent of the Declarant.

ARTICLE XIII.  
GENERAL PROVISIONS

Section 1. Enforcement. The Association, or any Owner shall have the right to enforce, by any proceeding at law or in equity; all restrictions, conditions, covenants, reservations, liens and charges now or hereafter imposed by the provisions of this Declaration. Failure by the Association or by any Owner to enforce any covenant or restriction herein contained shall in no event be deemed a waiver of the right to do so thereafter.

Section 2. Severability. Invalidation of any one of these covenants or restrictions by judgment or court order shall in no way affect any other provisions which shall remain in full force and effect.

Section 3. Amendment. The covenants and restrictions of this Declaration shall run with and bind the land and shall be perpetual. This Declaration may be amended by an instrument signed by the Owners representing Lots to which not less than 67% of the total votes have been allocated. Any amendment must be recorded. The following provisions may not be amended to delete or reduce any duties of the Association without the written consent of the City of Fridley:

- (a) Art. IV. Sec. 1 as to light fixtures or light standards along private roads;
- (b) Art. IV, Secs. 2, 3, and 4;
- (c) Art. IV-A;
- (d) Art. VII, Sec. 1, Subsections (l) and (m);
- (e) Art. VIII, Secs. 6 and 7;
- (f) Art. XIII, Sec. 3.

Section 4. Annexation. Additional residential or commercial property and Common Elements may be annexed to the property with the consent of the Declarant or Owners who represent seventy five percent (75%) of the Lots.

Section 5. FHA/VA. If the Common Interest Community has received approval from the Federal Housing Administration or the Department of Veterans Affairs, the following actions will require the prior approval of the Federal Housing Administration or the Department of Veterans Affairs, during any period of Declarant control: annexation of additional properties, dedication of Common Elements and amendment of this Declaration, the Articles of Incorporation of the Association or the Bylaws of the Association.

Section 6. Tender of Claims. In the event that any incident occurs which could reasonably give rise to a demand by the Association against the Declarant for indemnification pursuant to the Act, the Association shall promptly tender the defense of the action to its insurance carrier, and give Declarant written notice of such tender, the specific nature of the action and an opportunity to defend against the action.

Section 7. Conflicts Among Documents. In the event of any conflict among the provisions of the Act, this Declaration, the Bylaws of the Association or any Rules and Regulations adopted by the Association, the documents shall control in the following order of priority:

- (a) the Act;
- (b) this Declaration;
- (c) the Bylaws; and
- (d) the Rules and Regulations.

Section 8. Interpretation. As appropriate, each reference to a masculine pronoun shall include the feminine and neutral pronoun and each reference to a singular pronoun shall include the multiple pronoun and vice versa.

Section 9. Limited Common Elements. All portions of the Property other than the Lots are Common Elements. Certain portions of the Common Elements designed to serve a single Lot are, by operation of Section 515B.2-102(d) and (f) of the Act, Limited Common Elements allocated for the exclusive use by the respective Lots served thereby to the exclusion of other Lots. In addition, the driveways adjacent to and serving each Lot are Limited Common Elements allocated for the exclusive use of the respective Lots to the exclusion of the other Lots. Additionally, the entry area and air conditioning equipment serving each Lot and the fenced yard and/or the patio/deck area, if any, which are accessible from each Lot are Limited Common Elements allocated for the exclusive use of such Lot to the exclusion of the other Lots. The air conditioning equipment which is a Limited Common Element allocated to each Lot shall be maintained, repaired and replaced by the Owner of each such Lot at such Owner's sole cost and expense. All other portions of the Limited Common Elements shall be maintained as Common Elements under and pursuant to the provisions of Article IV hereof. The expense of any such maintenance and repair shall be charged to the Lot as a Common Expense under and pursuant to the provisions of Article III hereof.

Section 10. Condemnation. In the event of the taking of any of the Common Elements by eminent domain or any action or proceeding in lieu of eminent domain (hereinafter, "condemnation"), the Association shall represent the Owners in any such condemnation, or in negotiations, settlements and



agreements with the condemning authority, and each Owner hereby appoints the Association as his attorney-in-fact, irrevocably, for such purposes. If deemed necessary by the Association, it may obtain the services of a trustee to act on behalf of the Owners in carrying out any functions under this Section. In the event of a condemnation of part or all of the Common Elements, the award of proceeds of settlement shall be payable to the Association. All proceeds payable with respect to any condemnation of Common Elements shall be applied to the restoration or repair of such Common Elements remaining after such condemnation or to such other purposes as may be in accordance with the functions and powers of the Association and the welfare of the Owners.

If all of a Lot is taken through condemnation, or if so much of a Lot is taken that the remaining property cannot reasonably be used for a purpose allowed by this Declaration, then the entire Lot shall be considered condemned and the Owner's interest in the Common Elements and Association shall be deemed to cease on the date such condemnation is completed.

If part of a Lot is taken through condemnation, but the Lot can still be used for a purpose allowed by this Declaration, then there shall be no effect on the Lot Owner's interest in the Common Elements or the Association.

Any proceeds of any condemnation with respect to a Lot shall belong and be paid to the Owner thereof and his mortgagee, as their interests may appear.

Section 11. Dissolution. The common interest community created by this Declaration may only be terminated with the assent given in writing and signed by not less than the Owners holding eighty percent (80%) of the votes of the Association and eighty percent (80%) of the Eligible Mortgagees (each mortgagee having one vote for each Lot financed).

Upon termination of the common interest community, after payment of all the debts and obligations of the Association, all Lots, Common Elements, and Association property shall be administered in accordance with the provisions of the Act.

IN WITNESS WHEREOF, Declarant has caused this Declaration to be executed the date and year first above written.

THE ROTTLUND COMPANY, INC.

BY: 

Its: President



EXHIBIT A TO DECLARATION

COMMON INTEREST COMMUNITY NUMBER 23

THE VILLAGE HOMES OF CHRISTENSON CROSSING

Legal Description

Lots 1 through 55, inclusive, including Lots 1A and 6A, Block 1, Christenson Crossing, according to the plat on file and of record in the Office of the County Recorder, Anoka County, Minnesota, and the Office of the Registrar of Titles, Anoka County, Minnesota.

---

EXHIBIT B TO DECLARATION  
COMMON INTEREST COMMUNITY NUMBER 23  
THE VILLAGE HOMES OF CHRISTENSON CROSSING

Fence Easement

All that part of Blocks 7, 8, and 9, LOWELL ADDITION TO FRIDLEY PARK, according to the recorded plat thereof, Anoka County, Minnesota. Together with that part of the vacated Streets and Alleys adjoining said Blocks 7, 8, and 9. All lying North of the north line and its westerly extension of Sylvan Hills plat 8, according to the recorded plat thereof, and lying West of the west line of SYLVAN HILLS PLAT 6, according to the recorded plat thereof.

Said Permanent Easement being 4 feet wide easement, the east line thereof is described as beginning at the most northerly, northwest corner of Lot 1, Block 1, CHRISTENSON CROSSING, according to the recorded plat thereof; thence Southerly along the west line thereof, a distance of 349.95 feet and said strip terminating. And said Permanent Easement being 9 feet wide, the south line thereof is described as beginning at the termination of the last described strip; thence Westerly along the most southerly, north line of Lot 1, Block 1, said CHRISTENSON CROSSING, a distance of 350.00 feet and said strip terminating.

EXHIBIT C TO DECLARATION

COMMON INTEREST COMMUNITY NUMBER 23

THE VILLAGE HOMES OF CHRISTENSON CROSSING

Trailways: The Village Homes of Christenson Crossing

A Permanent Easement for Trail purposes over and across that part of Lot 1, Block 1, CHRISTENSON CROSSING, according to the recorded plat thereof, Anoka County, Minnesota. Said Easement being 10 feet wide, the centerline is described as follows:

Commencing at the most northerly, northwest corner of said Lot 1; thence South 0 degrees 13 minutes 20 seconds West on an assumed bearing along the westerly line of said Lot 1, a distance of 184.74 feet; thence South 60 degrees 00 minutes 00 seconds East along the northeasterly line of Lot 33, said Block 1, and the northwesterly extension of said Lot 33, a distance of 102.07 feet to the most easterly, northeast corner of said Lot 33; thence North 82 degrees 03 minutes 34 seconds East, a distance of 38.82 feet to the point of beginning of said Easement; thence Easterly on a non-tangential curve, concave to the south, having a radius of 60.93 feet, a central angle of 33 degrees 29 minutes 15 seconds, a chord of 35.11 feet, a chord bearing of South 73 degrees 28 minutes 59 seconds East, a distance of 35.61 feet; thence Easterly on a reverse curve, concave to the north, having a radius of 39.42 feet, a central angle of 46 degrees 22 minutes 25 seconds, a distance of 31.91 feet; thence Easterly on a reverse curve, concave to the south, having a radius of 48.67 feet, a central angle of 43 degrees 51 minutes 17 seconds, a distance of 37.25 feet; thence Southerly on a tangential curve, concave to the southwest, having a radius of 44.32 feet, a central angle of 59 degrees 46 minutes 38 seconds, a distance of 46.24 feet; thence Southerly on a reverse curve, concave to the east, having a radius of 61.82 feet, a central angle of 29 degrees 32 minutes 48 seconds, a distance of 31.88 feet; thence Southeasterly on a tangential curve, concave to the northeast, having a radius of 45.00 feet, a central angle of 77 degrees 59 minutes 11 seconds, a distance of 61.25 feet; thence Easterly on a reverse curve, concave to the south, having a radius of 151.01 feet, a central angle of 28 degrees 27 minutes 32 seconds, a distance of 75.05 feet; thence Easterly on a reverse curve, concave to the north, having a radius of 118.77 feet, a central angle of 31 degrees 18 minutes 17 seconds, a distance of 64.89 feet to the easterly line of said Lot 1 (also being the

southwesterly right-of-way line of 3rd Street) and there terminating.

The sidelines of said Easement are to be lengthened or shortened so as to terminate on the easterly line of said Lot 1.

**TORRENS**

Receipt # <u>87434</u>	<input type="checkbox"/> Certified Copy
Date/Time: <u>12/19/96 13:10</u>	<input type="checkbox"/> Tax Liens/Releases
Doc. Order <u>1</u> of <u>2</u>	<input type="checkbox"/> Multi-Co. Doc. Tax Paid
Checked by: <u>KB</u> Filing Fees: <u>19.50</u>	<input type="checkbox"/> Transfer <input type="checkbox"/> New Desc.
Delinquents _____ Pins _____	<input type="checkbox"/> Division <input type="checkbox"/> GAC
From Cert. # <u>80375 A</u>	<input type="checkbox"/> Status <input type="checkbox"/> Def. Spec.
# of New Certs.: <u>0</u> Typed _____ Comp. Entry _____	
Stamp _____	

BK 253 PG 115 NO 80275

**ABSTRACT**

Receipt # <u>87427</u>	<input type="checkbox"/> Certified Copy
Date/Time: <u>12/20/96 9:20</u>	<input type="checkbox"/> Tax Liens/Releases
Doc. Order <u>1</u> of <u>2</u>	<input type="checkbox"/> Multi-Co Doc Tax Pd
✓ by: Recordability: <u>BP</u>	<input type="checkbox"/> Transfer <input type="checkbox"/> New Desc.
Filing Fees: <u>32.50</u>	<input type="checkbox"/> Division <input type="checkbox"/> GAC
Delqs: _____ Pins: <u>91</u>	<input type="checkbox"/> Status <input type="checkbox"/> Def. Spec.

DOCUMENT NO. 1256868.0 ABSTRACT

**ANOKA COUNTY MINNESOTA**

I HEREBY CERTIFY THAT THE WITHIN INSTRUMENT WAS FILED IN THIS OFFICE FOR RECORD ON **DEC 20 96** AND WAS DULY RECORDED. AT **9:20 AM** FEES AND TAXES IN THE AMOUNT OF **\$32.50** PAID.

RECEIPT NO. **96087427**  
EDWARD M. TRESKA

ANOKA COUNTY PROPERTY TAX ADMINISTRATOR/RECORDER/REGISTRAR OF TITLES

BY BLP  
DEPUTY PROPERTY TAX ADMINISTRATOR/RECORDER/REGISTRAR OF TITLES

**FILE IN TORRENS**

# CHRISTENSON CROSSING

KNOW ALL PERSONS BY THESE PRESENTS: That Fridley Housing and Redevelopment Authority, Minnesota, a public body and Corporate politic under the laws of Minnesota, fee owner of the following described property situated in the County of Anoka, State of Minnesota, to wit:

That part of Block 12, LOWELL ADDITION TO FRIDLEY PARK, according to the recorded plat thereof, Anoka County, Minnesota ; and that part of the vacated alleys in said Block 12, described as follows:

That part of the Northwest Quarter of the Southwest Quarter of Section 14, Township 30, Range 24 , Anoka County, Minnesota; Beginning at a point on the north line of said Northwest Quarter of the Southwest Quarter, distant 1043.58 feet Easterly of the northwest corner thereof; thence Southerly, parallel with the westerly line of University Avenue, also known as State Trunk Highway No. 56, as same is laid out and constructed, a distance of 158.00 feet; thence Easterly, parallel with the north line of said Northwest Quarter of the Southwest Quarter, a distance of 155.22 feet, to the westerly line of said University Avenue ( State Trunk Highway No. 56); thence Northerly along said westerly line of University Avenue, a distance of 158.00 feet to the north line of the Northwest Quarter of the Southwest Quarter of said Section 14; thence Westerly along said north line, a distance of 155.22 feet to the point of beginning. Except the north 33 feet thereof dedicated for Mississippi Street on said LOWELL ADDITION TO FRIDLEY PARK plat.

And  
That part of vacated 64 1/2 Avenue and vacated Service Drive , according to the recorded plat of SYLVAN HILLS PLAT 5, being 10 feet wide, the north line thereof is described as beginning at the southeast corner of Lot 2, Block 1, SYLVAN HILLS PLAT 5; thence Easterly along the north line of said 64 1/2 Avenue, 155.22 feet to the east line of said Service Drive ( west line of University Avenue ) and there terminating. ( The east and west lines of said 10 foot wide strip are to be parallel with the east line of said Service Drive )

And  
The North 71.00 feet of the East 20.00 feet of Lot 2, Block 1, SYLVAN HILLS PLAT 5, according to the recorded plat thereof.

And that The Rottlund Company, Inc. , a Minnesota corporation, fee owner of the following described property situated in the County of Anoka, State of Minnesota, to wit:

Lot 1, Block 1, SYLVAN HILLS PLAT 5, according to the recorded plat thereof, and that part of the vacated 64 1/2 Avenue , vacated Service Drive, and vacated 3rd Street that accrue to said Lot 1 by the vacation thereof. Except that part of vacated 64 1/2 Avenue and vacated Service Drive , being a strip 10 feet wide, the north line thereof is described as beginning at the southeast corner of Lot 2, Block 1, SYLVAN HILLS PLAT 5; thence Easterly along the north line of said 64 1/2 Avenue, 155.22 feet to the east line of said Service Drive ( west line of University Avenue ) and there terminating. ( The east and west lines of said 10 foot wide strip are to be parallel with the east line of said Service Drive )

And  
Lot 2, Block 1, SYLVAN HILLS PLAT 5, according to the recorded plat thereof, and that part of the vacated 64 1/2 Avenue , that accrue to said Lot 2 by the vacation thereof. Except the North 71.00 feet of the East 20.00 feet of said Lot 2.

And  
The East 75.1 feet of the North 125.00 feet of Lot 3, Block 1, SYLVAN HILLS PLAT 5, according to the recorded plat thereof, and that part of the vacated 64 1/2 Avenue , that accrue to that part of said Lot 3 by the vacation thereof.

And  
That part of Lot 4, Block 1, SYLVAN HILLS PLAT 5, according to the recorded plat thereof, lying East of the West 195.00 feet thereof ; and that part of vacated 3rd Street that accrue to that part of said Lot 4 by the vacation thereof.

And  
The West 195.00 feet of Lot 4, Block 1, SYLVAN HILLS PLAT 5, according to the recorded plat thereof.

And  
Lots 1 and 2, Block 1, SYLVAN HILLS PLAT 6, according to the recorded plat thereof.

And  
Lot 1, Block 1, SYLVAN HILLS PLAT 7, according to the recorded plat thereof.

And  
Lot 1 , Block 1, SYLVAN HILLS PLAT 8, according to the recorded plat thereof.

Have caused the same to be surveyed and platted as CHRISTENSON CROSSING and do hereby donate and dedicate to the public, for public use forever, the streets, avenue and dedicates the drainage and utility easements, as shown on the plat.

In witness whereof, said Fridley Housing and Redevelopment Authority, Minnesota, a public body and Corporate politic under the laws of the State of Minnesota, have caused these presents to be signed by its proper officers this 15<sup>th</sup> day of May, 1996.

In witness whereof said The Rottlund Company, Inc. , a Minnesota corporation, have caused these presents to be signed by its proper officers this 15<sup>th</sup> day of May, 1996.

SIGNED:  
Fridley Housing and Redevelopment Authority  
By: Lawrence R. Commers, Chairman  
Lawrence R. Commers  
William W. Burns, Executive Director  
William W. Burns

The Rottlund Company, Inc.  
By: [Signature] its EXECUTIVE VICE PRESIDENT

STATE OF MINNESOTA  
COUNTY OF ANOKA

The foregoing instrument was acknowledged before me this 15<sup>th</sup> day of May, 1996 , by Lawrence R. Commers , chairman; and William W. Burns , executive director of Fridley Housing and Redevelopment Authority, Minnesota, a public body and Corporate politic under the laws of the State of Minnesota, on behalf of the Fridley Housing and Redevelopment Authority.

[Signature]  
Notary Public, Anoka County, Minnesota  
My Commission Expires 1-31-2000

STATE OF MINNESOTA  
COUNTY OF RAMSEY

The foregoing instrument was acknowledged before me this 7<sup>th</sup> day of May, 1996, by Todd M. Stutz , as Executive Vice President of The Rottlund Company , Inc. , a Minnesota corporation , on behalf of said corporation.

[Signature]  
Notary Public, Hennepin County, Minnesota  
My Commission Expires Jan 31, 2000

I, Wayne D. Cordes, hereby certify that I have surveyed and platted the property described on this plat as CHRISTENSON CROSSING ; that this plat is a correct representation of said survey; that all distances are correctly shown on the plat in feet and hundredths of a foot; that all monuments have been correctly placed in the ground as shown on said plat or will be placed as required by the local governmental unit as designated on said plat, in accordance to Minnesota Statutes, Section 505.02 , Subd. 1; that the outside boundary lines are correctly designated on the plat; and that there are no wetlands or public highways to be designated other than as shown.

Wayne D. Cordes  
Wayne D. Cordes, Land Surveyor  
Minnesota License No. 14675

STATE OF MINNESOTA  
COUNTY OF Hennepin

The foregoing Surveyor's Certificate was acknowledged before me this 6<sup>th</sup> day of May, 1996, by Wayne D. Cordes, Land Surveyor, Minnesota License No. 14675.

Christian C. Larsen  
Notary Public, Washington County, Minnesota.  
My Commission Expires January 31, 2000

This plat of CHRISTENSON CROSSING was approved and accepted by the City Council of the City of Fridley, Minnesota, at a regular meeting thereof held this 4<sup>th</sup> day of March, 1996. If applicable, the written comments and recommendations of the Commissioner of Transportation and the County Highway Engineer have been received by the City or the prescribed 30 - day period has elapsed without receipt of such comments and recommendations, as provided by Minnesota Statutes, Section 505.03, Subdivision 2.

William J. [Signature] Mayor  
William A. Champa Clerk

This plat has been checked and approved this 15<sup>th</sup> day of May, 1996.

By: [Signature]  
Merlyn D. Anderson  
Anoka County Surveyor

# 1218860  
OFFICE OF COUNTY RECORDER  
STATE OF MINNESOTA, COUNTY OF ANOKA  
I hereby certify that the within instrument was filed in this office for record on the 15<sup>th</sup> day of May, 1996 at 3:30 o'clock P.M., and was duly recorded in book 52 of page 41.  
[Signature]  
County Recorder  
By: [Signature]  
Deputy

281100  
Office of REGISTRAR OF TITLES  
STATE OF MINNESOTA  
COUNTY OF ANOKA  
I hereby certify that the within instrument was filed in this office on May 17 1996 at 3:30 o'clock P.M.  
[Signature]  
Deputy Registrar of Titles

I HEREBY CERTIFY THAT THE COUNTY AND DISTRICT TAXES ON THE LAND DESCRIBED WITHIN ARE PAID AND THE TRANSFER IS  
ENTERED May 17 1996  
BY [Signature]  
DEPUTY PROPERTY TAX ADMINISTRATOR

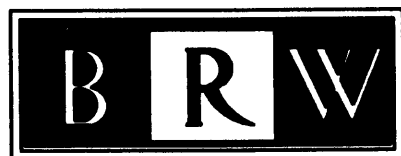



# CHRISTENSON CROSSING

CITY OF FRIDLEY  
COUNTY OF ANOKA

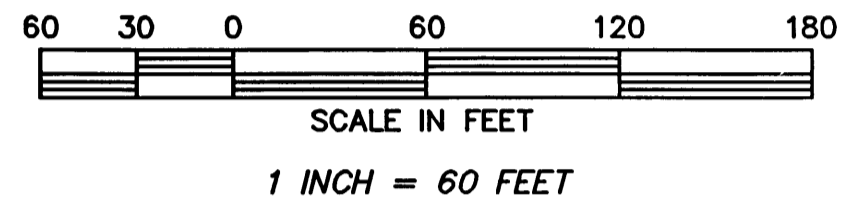
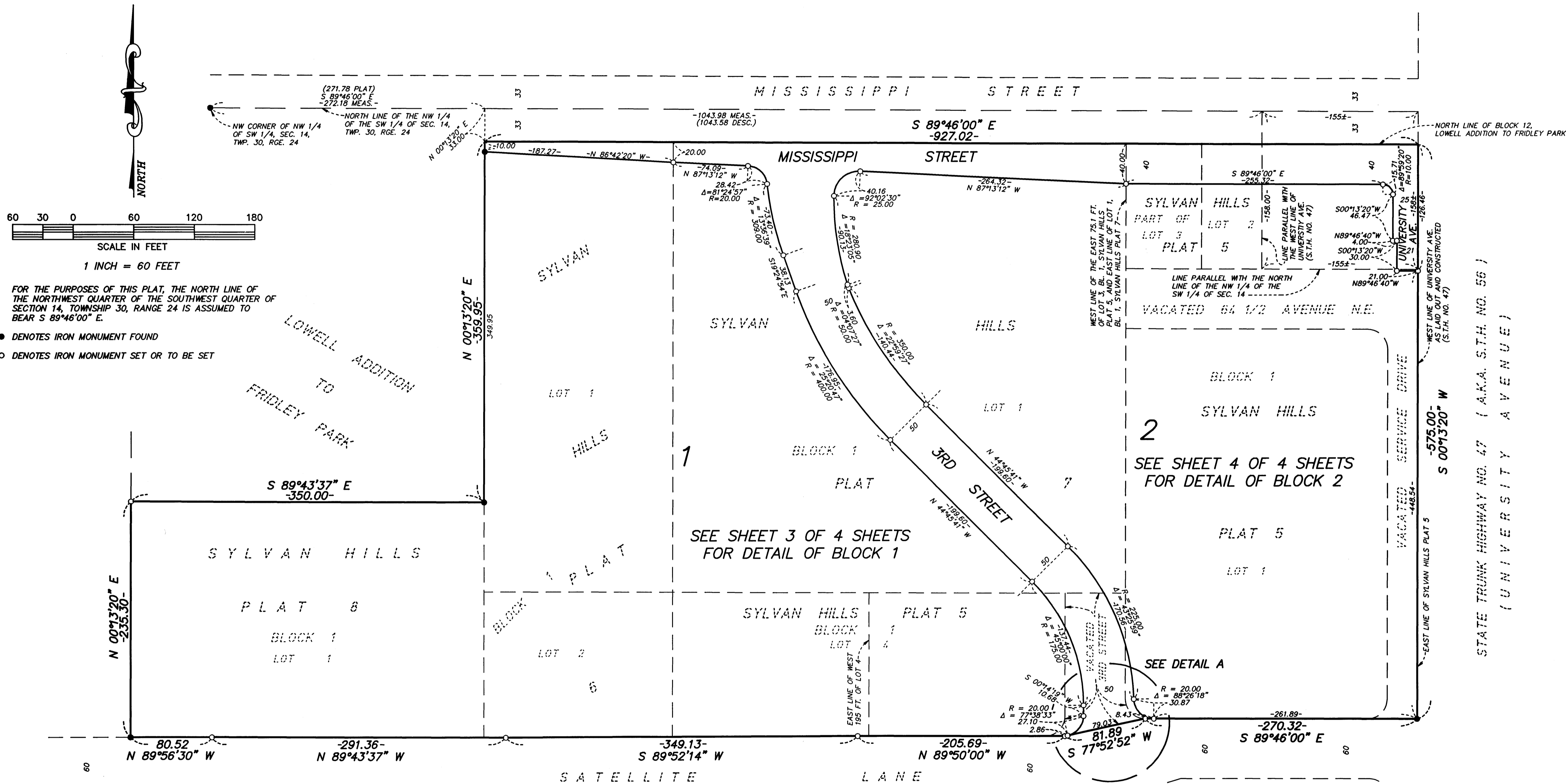

FOR THE PURPOSES OF THIS PLAT, THE NORTH LINE OF THE NORTHWEST QUARTER OF THE NORTHWEST QUARTER OF SECTION 14, TOWNSHIP 30, RANGE 24 IS ASSUMED TO BEAR S 89°46'00" E.

- DENOTES IRON MONUMENT FOUND
- DENOTES IRON MONUMENT SET OR TO BE SET

LOWELL ADDITION TO FRIDLEY PARK

SEE SHEET 3 OF 4 SHEETS FOR DETAIL OF BLOCK 1

SEE SHEET 4 OF 4 SHEETS FOR DETAIL OF BLOCK 2

SEE DETAIL A

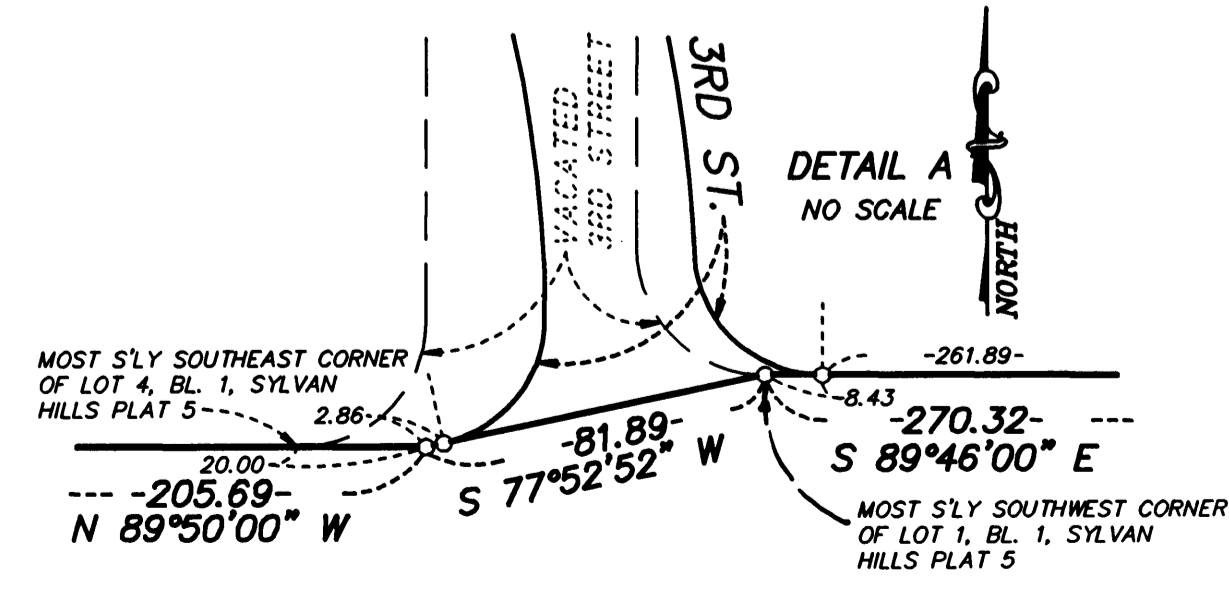

# CHRISTENSON CROSSING

MISSISSIPPI STREET

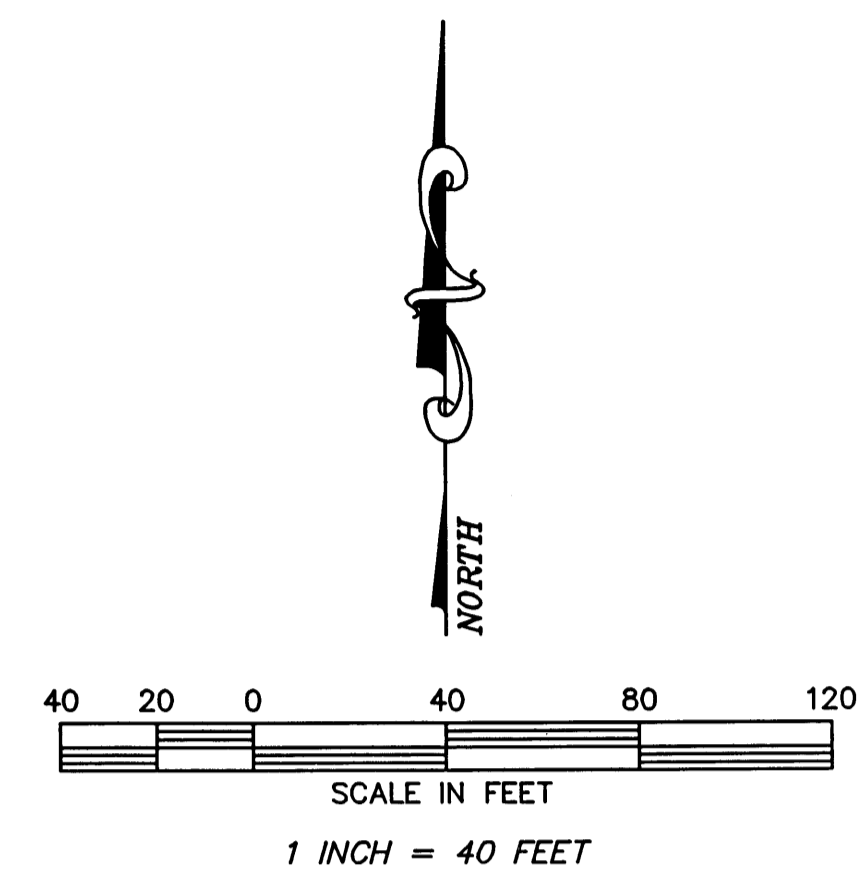

FOR THE PURPOSES OF THIS PLAT, THE NORTH LINE OF THE NORTHWEST QUARTER OF THE SOUTHWEST QUARTER OF SECTION 14, TOWNSHIP 30, RANGE 24 IS ASSUMED TO BEAR S 89°46'00" E.

- DENOTES IRON MONUMENT FOUND
- DENOTES IRON MONUMENT SET OR TO BE SET

LOWELL ADDITION  
TO FRIDLEY PARK

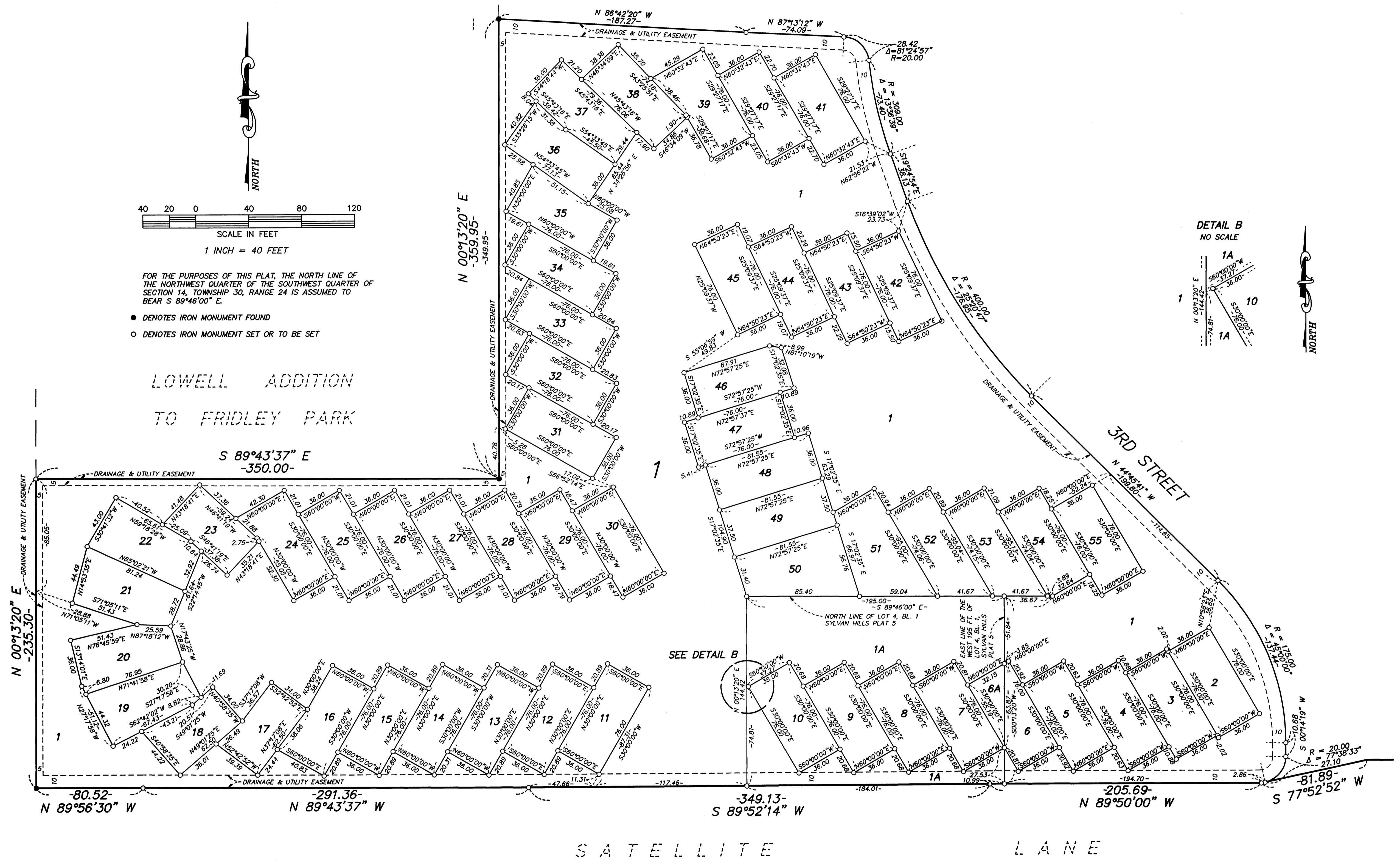

# CHRISTENSON CROSSING

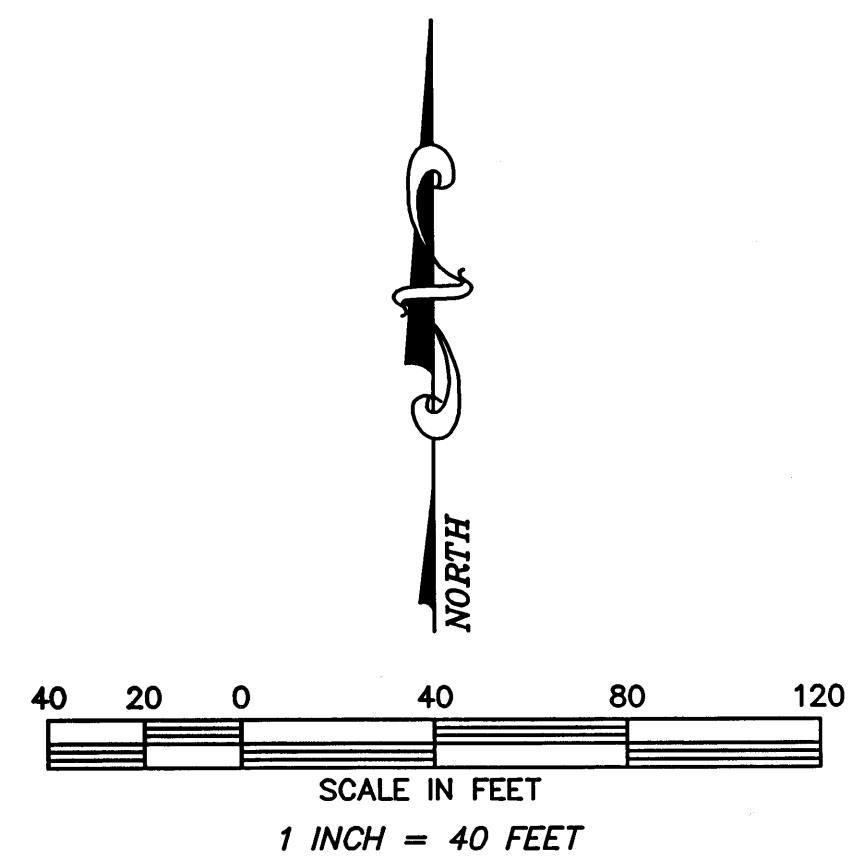
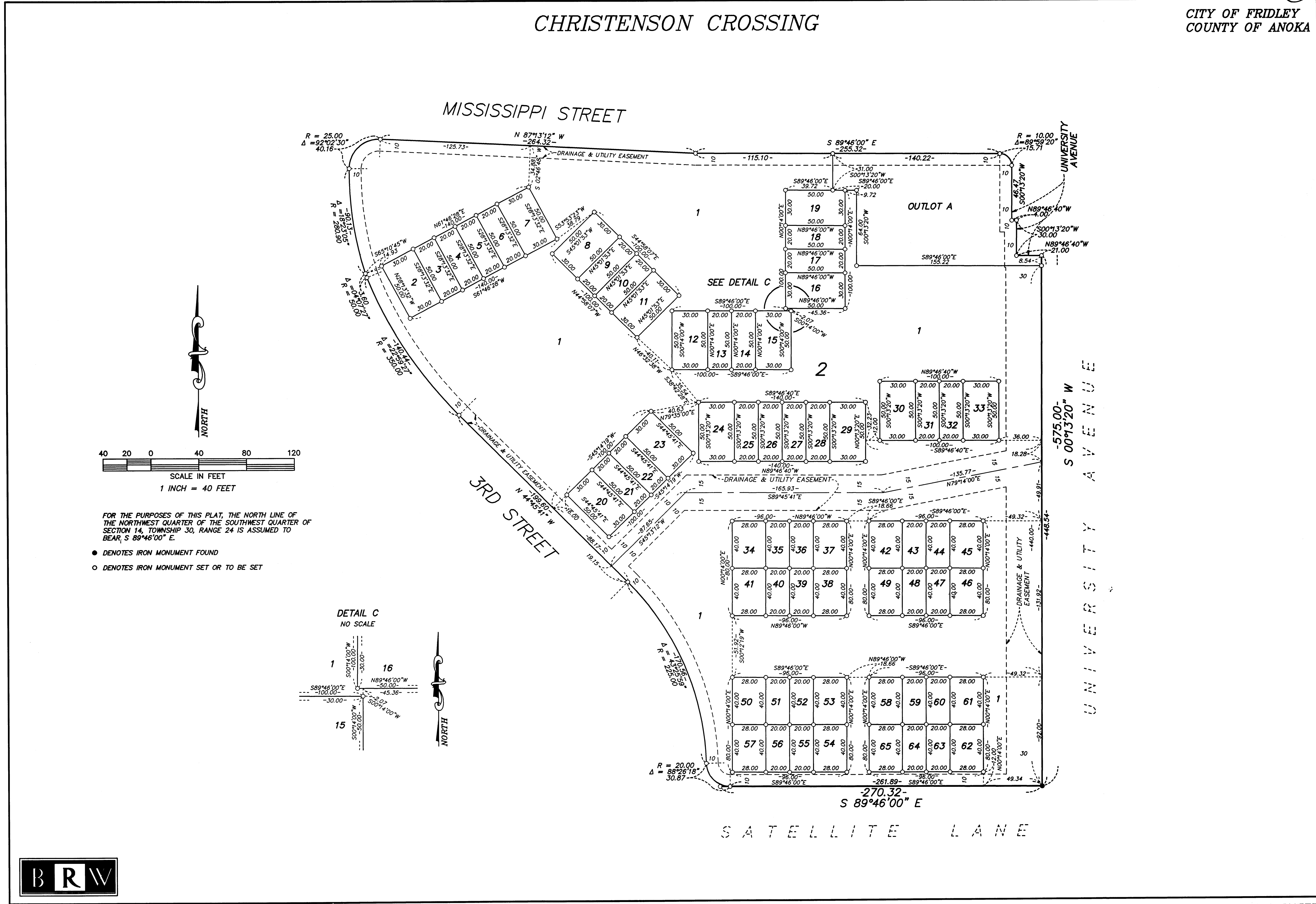

FOR THE PURPOSES OF THIS PLAT, THE NORTH LINE OF THE NORTHWEST QUARTER OF THE SOUTHWEST QUARTER OF SECTION 14, TOWNSHIP 30, RANGE 24 IS ASSUMED TO BEAR, S 89°46'00" E.

- DENOTES IRON MONUMENT FOUND
- DENOTES IRON MONUMENT SET OR TO BE SET

