

CIC NUMBER 27

MARSHAN LAKE CONDOMINIUMS, A COMMON INTEREST COMMUNITY NINTH SUPPLEMENTAL CIC PLAT

This CIC plat has been recorded as part of the declaration filed as document number 1396970 on the 29th day of December, 1998.

I, Jeffrey N. Caine, do hereby certify that the work was undertaken by or reviewed and approved by me for this NINTH SUPPLEMENTAL CIC NUMBER 27, MARSHAN LAKE CONDOMINIUMS, A COMMON INTEREST COMMUNITY, being located upon:

That part of Government Lot 2, Section 20, Township 31, Range 22, Anoka County, Minnesota, described as follows:

Commencing at the southeast corner of the north 849.40 feet of the west 240.00 feet of said Government Lot 2 (for the purposes of this description the west line of said Government Lot 2 is assumed to have a bearing of South 00 degrees 18 minutes 08 seconds West); thence North 82 degrees 52 minutes 55 seconds East, a distance of 38.49 feet; thence South 00 degrees 18 minutes 08 seconds West, parallel with the west line of said Government Lot 2, a distance of 417.58 feet to the north line of the south 60.00 feet of said Government Lot 2; thence North 00 degrees 18 minutes 08 seconds East, parallel with said west line, a distance of 314.19 feet; thence northerly along a tangential curve, concave to the east, having a radius of 230.00 feet and a central angle of 17 degrees 39 minutes 52 seconds, a distance of 70.91 feet; thence North 17 degrees 58 minutes 00 seconds East, tangent to said curve, a distance of 353.97 feet; thence northeasterly along a tangential curve, concave to the southeast, having a radius of 2572.72 feet and a central angle of 06 degrees 44 minutes 00 seconds, a distance of 302.35 feet; thence northeasterly along a compound curve, concave to the southwest, having a radius of 130.00 feet and a central angle of 65 degrees 48 minutes 53 seconds, a distance of 149.33 feet to a point to be hereinafter known as "Point C"; thence South 89 degrees 29 minutes 07 seconds East, tangent to said curve, a distance of 72.11 feet; thence southeasterly along a tangential curve, concave to the southwest, having a radius of 130.00 feet and a central angle of 59 degrees 16 minutes 06 seconds, a distance of 134.48 feet to the point of beginning of the tract of land to be described; thence North 74 degrees 29 minutes 18 seconds East, not tangent to said curve, a distance of 14.13 feet; thence northeasterly along a tangential curve, concave to the northwest, having a radius of 17.00 feet and a central angle of 57 degrees 27 minutes 52 seconds, a distance of 17.05 feet; thence South 60 degrees 00 minutes 26 seconds East, not tangent to said curve, a distance of 38.99 feet; thence South 72 degrees 58 minutes 34 seconds East, a distance of 108.92 feet to the point of intersection with a line described as follows:

Commencing at said "Point C"; thence South 89 degrees 29 minutes 07 seconds East, a distance of 72.11 feet; thence southeasterly along a line to be hereinafter known as "Line D", said line being a tangential curve, concave to the southwest, having a radius of 130.00 feet and a central angle of 106 degrees 30 minutes 33 seconds, a distance of 241.66 feet to the point of beginning of a line to be hereinafter known as "Line A"; and said "Line D" there terminating; thence South 17 degrees 01 minutes 26 seconds West, tangent to said curve, a distance of 299.93 feet to a point to be hereinafter known as "Point D"; thence South 17 degrees 01 minutes 26 seconds West, a distance of 21.82 feet; thence southerly along a tangential curve, concave to the east, having a radius of 100.00 feet and a central angle of 09 degrees 33 minutes 17 seconds, a distance of 16.68 feet; thence South 07 degrees 28 minutes 09 seconds West, tangent to said curve, a distance of 168.18 feet and said "Line A" there terminating; thence South 82 degrees 31 minutes 51 seconds East, a distance of 130.00 feet; thence North 07 degrees 28 minutes 09 seconds East, a distance of 196.12 feet to the point of intersection with a line which bears South 77 degrees 52 minutes 12 seconds East from said "Point D"; said point of intersection being the point of beginning of the line to be described; thence North 17 degrees 01 minute 26 seconds East, a distance of 397.85 feet, and said line there terminating.

thence South 17 degrees 01 minute 26 seconds West along said line, a distance of 200.85 feet to a point distant 197.00 feet northeasterly of the point of beginning of said line; thence North 72 degrees 58 minutes 34 seconds West, a distance of 184.95 feet to the intersection with a line drawn parallel with and distant 60.00 feet northwesterly of said Line A, as measured at right angles thereto; thence North 17 degrees 01 minute 26 seconds East along said parallel line, a distance of 201.77 feet to the point of intersection with said "Line D"; thence southeasterly along said "Line D", a distance of 23.10 feet to the point of beginning.

And the Additional Real Estate described as follows:

That part of Government Lot 2, Section 20, Township 31, Range 22, Anoka County, Minnesota, lying easterly of the easterly right-of-way line of Lake Drive, formerly known as State Trunk Highway No. 49, said easterly right-of-way line is described as follows:

Beginning at a point on the north line of said Government Lot 2, distant 354.43 feet easterly of the northwest corner thereof, for the purposes of this description the west line of said Government Lot 2 is assumed to bear South 00 degrees 18 minutes 08 seconds West; thence South 25 degrees 48 minutes 00 seconds West, a distance of 118.98 feet; thence southwesterly along a tangential curve, concave to the southeast, having a radius of 2819.22 feet and a central angle of 07 degrees 50 minutes 00 seconds, a distance of 385.44 feet; thence South 17 degrees 58 minutes 00 seconds West, tangent to said curve, a distance of 532.41 feet to the west line of said Government Lot 2, and there terminating.

EXCEPT the following 5 parcels:

Exception No. 1:

That part of Government Lot 2, Section 20, Township 31, Range 22, Anoka County, Minnesota, described as follows:

Beginning at the southeast corner of the north 849.40 feet of the west 240.00 feet of said Government Lot 2 (for the purposes of this description the west line of said Government Lot 2 is assumed to have a bearing of South 00 degrees 18 minutes 08 seconds West); thence North 82 degrees 52 minutes 55 seconds East, a distance of 38.49 feet; thence South 00 degrees 18 minutes 08 seconds West, parallel with the west line of said Government Lot 2, a distance of 417.58 feet to the north line of the south 60.00 feet of said Government Lot 2; thence North 89 degrees 20 minutes 25 seconds West, along said north line, a distance of 278.18 feet to the west line of said Government Lot 2; thence northerly along said west line, a distance of 287.02 feet to said easterly right-of-way line of Lake Drive; thence North 17 degrees 58 minutes 00 seconds East along said easterly right-of-way line, a distance of 130.76 feet to the intersection with a line drawn westerly, parallel with the north line of said Government Lot 2, from the point of beginning of the property being excepted; thence South 89 degrees 29 minutes 07 seconds East, along said parallel line, a distance of 200.33 feet to said point of beginning.

Exception No. 2:

That part of Government Lot 2, Section 20, Township 31, Range 22, Anoka County, Minnesota, lying easterly of the following described line:

Beginning at a point on the south line of said Government Lot 2, distant 1130.00 feet east of the southwest corner thereof; thence North 13 degrees 21 minutes 20 seconds East, a distance of 690 feet, more or less, to a point of intersection with the shoreline of Marshan Lake and there terminating. For the purposes of this description, the south line of said Government Lot 2 is assumed to have a bearing of East.

Exception No. 3:

The South 60.00 feet of said Government Lot 2, Section 20, Township 31, Range 22.

Exception No. 4:

That part of Government Lot 2, Section 20, Township 31, Range 22, Anoka County, Minnesota, described as follows:

Commencing at the southeast corner of the north 849.40 feet of the west 240.00 feet of said Government Lot 2 (for the purposes of this description the west line of said Government Lot 2 is assumed to have a bearing of South 00 degrees 18 minutes 08 seconds West); thence North 82 degrees 52 minutes 55 seconds East, a distance of 38.49 feet; thence South 00 degrees 18 minutes 08 seconds West, parallel with the west line of said Government Lot 2, a distance of 417.58 feet to the north line of the south 60.00 feet of said Government Lot 2; and to the point of beginning of a line to be hereinafter known as "Line C"; thence North 00 degrees 18 minutes 08 seconds East, parallel with said west line, a distance of 314.19 feet; thence northerly along a tangential curve, concave to the east, having a radius of 230.00 feet and a central angle of 17 degrees 39 minutes 52 seconds, a distance of 70.91 feet; thence North 17 degrees 58 minutes 00 seconds East, tangent to said curve, a distance of 353.97 feet to a point to be hereinafter known as "Point A"; thence North 17 degrees 58 minutes 00 seconds East, a distance of 134.48 feet; thence North 74 degrees 29 minutes 18 seconds East, not tangent to said curve, a distance of 14.13 feet; thence northeasterly along a tangential curve, concave to the northwest, having a radius of 17.00 feet and a central angle of 57 degrees 27 minutes 52 seconds, a distance of 17.05 feet; thence South 60 degrees 00 minutes 26 seconds East, tangent to said curve, a distance of 38.99 feet; thence South 72 degrees 58 minutes 34 seconds East, a distance of 108.92 feet to the point of intersection with a line described as follows:

Commencing at said "Point C"; thence South 89 degrees 29 minutes 07 seconds East, a distance of 72.11 feet; thence southeasterly along a line to be hereinafter known as "Line D", said line being a tangential curve, concave to the southwest, having a radius of 130.00 feet and a central angle of 106 degrees 30 minutes 33 seconds, a distance of 241.66 feet to the point of beginning of a line to be hereinafter known as "Line A"; and said "Line D" there terminating; thence South 17 degrees 01 minutes 26 seconds West, tangent to said curve, a distance of 299.93 feet to a point to be hereinafter known as "Point D"; thence South 17 degrees 01 minutes 26 seconds West, a distance of 21.82 feet; thence southerly along a tangential curve, concave to the east, having a radius of 100.00 feet and a central angle of 09 degrees 33 minutes 17 seconds, a distance of 16.68 feet; thence South 07 degrees 28 minutes 09 seconds West, tangent to said curve, a distance of 168.18 feet and said "Line A" there terminating; thence South 82 degrees 31 minutes 51 seconds East, a distance of 130.00 feet; thence North 07 degrees 28 minutes 09 seconds East, a distance of 196.12 feet to the point of intersection with a line which bears South 77 degrees 52 minutes 12 seconds East from said "Point D"; said point of intersection being the point of beginning of the line to be described; thence North 17 degrees 01 minute 26 seconds East, a distance of 397.85 feet, and said line there terminating.

thence South 17 degrees 01 minute 26 seconds West along said line, a distance of 397.85 feet to the point of beginning of said line; thence South 07 degrees 28 minutes 09 seconds West, a distance of 606.87 feet to the north line of the south 60.00 feet of said Government Lot 2; thence North 89 degrees 20 minutes 25 seconds West along said north line, a distance of 191.35 feet to the intersection with a line drawn parallel with and distant 60.00 feet westerly of the southerly extension of said Line A, as measured at right angles thereto; thence northerly along said parallel line, a distance of 866.06 feet to a point on said parallel line distant 173.52 feet southerly of the point of intersection of the northerly extension of said parallel line with said "Line D"; thence North 72 degrees 58 minutes 34 seconds West, a distance of 215.06 feet to the intersection with a line drawn parallel with and distant 60.00 feet easterly of, as measured at right angles to, said "Line C"; thence southerly along said parallel line, a distance of 963.00 feet to the north line of the south 60.00 feet of said Government Lot 2; thence westerly along said north line a distance of 60.00 feet to the point of beginning of said "Line C"; thence northerly along said "Line C", a distance of 584.94 feet to said "Point A"; thence North 71 degrees 00 minutes 13 seconds West, a distance of 246.54 feet to the easterly right-of-way line of Lake Drive, formerly known as State Trunk Highway No. 49, said easterly right-of-way line is described as follows:

Beginning at a point on the north line of said Government Lot 2, distant 354.43 feet easterly of the northwest corner thereof, for the purposes of this description, the west line of said Government Lot 2 is assumed to bear South 00 degrees 18 minutes 08 seconds West; thence South 25 degrees 48 minutes 00 seconds West, a distance of 118.98 feet; thence southwesterly along a tangential curve, concave to the southeast, having a radius of 2819.22 feet and a central angle of 07 degrees 50 minutes 00 seconds, a distance of 385.44 feet; thence South 17 degrees 58 minutes 00 seconds West, tangent to said curve, a distance of 532.41 feet to the west line of said Government Lot 2, and there terminating.

thence northerly along said easterly right-of-way line, a distance of 437.59 feet to the intersection with a line which bears North 71 degrees 05 minutes 18 seconds West from the point of beginning of the property being excepted; thence South 71 degrees 05 minutes 18 seconds East, a distance of 247.49 feet to said point of beginning.

Exception No. 5:

That part of Government Lot 2, Section 20, Township 31, Range 22, Anoka County, Minnesota, described as follows:

Beginning at a point on the north line thereof, distant 61.33 feet westerly of the southwest corner of Lot 14, Block 5, SHORES OF MARSHAN LAKE, according to the recorded plat thereof, Anoka County, Minnesota; thence westerly along said north line, a distance of 783.65 feet to the intersection with the easterly right-of-way line of Lake Drive, formerly known as State Trunk Highway No. 49, said easterly right-of-way line is described as follows:

Beginning at a point on the north line of said Government Lot 2, distant 354.43 feet easterly of the northwest corner thereof, for the purposes of this description the west line of said Government Lot 2 is assumed to bear South 00 degrees 18 minutes 08 seconds West; thence South 25 degrees 48 minutes 00 seconds West, a distance of 118.98 feet; thence southwesterly along a tangential curve, concave to the southeast, having a radius of 2819.22 feet and a central angle of 07 degrees 50 minutes 00 seconds, a distance of 385.44 feet; thence South 17 degrees 58 minutes 00 seconds West, tangent to said curve, a distance of 532.41 feet to the west line of said Government Lot 2, and there terminating.

thence southwesterly along said easterly right-of-way line, a distance of 216.53 feet to the intersection with a line which bears North 71 degrees 05 minutes 18 seconds West from a point described as follows:

Commencing at the southeast corner of the north 849.40 feet of the west 240.00 feet of said Government Lot 2; thence North 82 degrees 52 minutes 55 seconds East, a distance of 38.49 feet; thence South 00 degrees 18 minutes 08 seconds West, parallel with the west line of said Government Lot 2, a distance of 417.58 feet to the north line of the south 60.00 feet of said Government Lot 2; thence North 00 degrees 18 minutes 08 seconds East, parallel with said west line, a distance of 314.19 feet; thence northerly along a tangential curve, concave to the east, having a radius of 230.00 feet and a central angle of 17 degrees 39 minutes 52 seconds, a distance of 70.91 feet; thence North 17 degrees 58 minutes 00 seconds East, tangent to said curve, a distance of 353.97 feet; thence northeasterly along a tangential curve, concave to the southeast, having a radius of 2572.72 feet and a central angle of 06 degrees 44 minutes 00 seconds, a distance of 283.88 feet to the point being described.

thence South 71 degrees 05 minutes 18 seconds East, a distance of 247.49 feet to said point; thence northeasterly along said 2572.72 foot radius curve, having a central angle of 00 degrees 24 minutes 41 seconds, a distance of 18.47 feet; thence northeasterly along a compound curve, concave to the southeast, having a radius of 130.00 feet and a central angle of 65 degrees 48 minutes 53 seconds, a distance of 149.33 feet; thence South 89 degrees 29 minutes 07 seconds East, tangent to said curve, a distance of 72.11 feet; thence southeasterly along a tangential curve, concave to the southwest, having a radius of 130.00 feet and a central angle of 59 degrees 16 minutes 06 seconds, a distance of 134.48 feet; thence North 74 degrees 29 minutes 18 seconds East, not tangent to said curve, a distance of 14.13 feet; thence northeasterly along a tangential curve, concave to the northwest, having a radius of 17.00 feet and a central angle of 57 degrees 27 minutes 52 seconds, a distance of 17.05 feet; thence North 17 degrees 01 minutes 26 seconds East, tangent to said curve, a distance of 187.37 feet; thence South 86 degrees 51 minutes 19 seconds East, a distance of 191.60 feet to a point on the westerly line of a 60.00 foot radius circle, said point is described as follows:

Commencing at a point on the north line of said Government Lot 2, distant 61.33 feet westerly of the southwest corner of said Lot 14, Block 5, SHORES OF MARSHAN LAKE; thence southerly at right angles to said north line, a distance of 60.00 feet to the center of said 60.00 foot radius circle; thence North 87 degrees 51 minutes 07 seconds West, a distance of 60.00 feet to the point being described.

thence northeasterly along the westerly line of said 60.00 foot radius circle, being a curve concave to the southeast, having a central angle of 88 degrees 22 minutes 00 seconds, a distance of 92.54 feet to the point of beginning.

Fully and accurately depicts all information described by Minnesota Statutes, Section 515B.2-110.

Dated this 29th day of December, 1998.

Jeffrey N. Caine
Jeffrey N. Caine, Land Surveyor
Minnesota License No. 12251

STATE OF MINNESOTA
COUNTY OF Anoka

The foregoing instrument was acknowledged before me this 29th day of December, 1998, by Jeffrey N. Caine, a licensed Land Surveyor.

Jill McKent
Notary Public, Anoka County, Minnesota
My Commission Expires 01-31-00

Pursuant to Minnesota Statutes, Chapter 389.09, Subd. 2, this CIC Plat has been reviewed and is approved this 31st day of DECEMBER, 1998.

By: *Larry D. Hain*
LARRY D. HAIN County Surveyor

Doc# 1396970.

FILED
ON THE 31st of December 1998
2 BOOKS P
BY *Edward M. Freska*
EDWARD M. FRESKA
COUNTY CLERK

By: ELC
COUNTY CLERK
COUNTY OF ANOKA
PROPERTY TAX ADMINISTRATOR

LAND SURVEYORS, INC.
CAINE & ASSOCIATES

Rect# 1999003621 \$ 319.50

SHEET 1 OF 4 SHEETS

CIC NUMBER 27

MARSHAN LAKE CONDOMINIUMS, A COMMON INTEREST COMMUNITY

NINTH SUPPLEMENTAL CIC PLAT

SITE PLAN

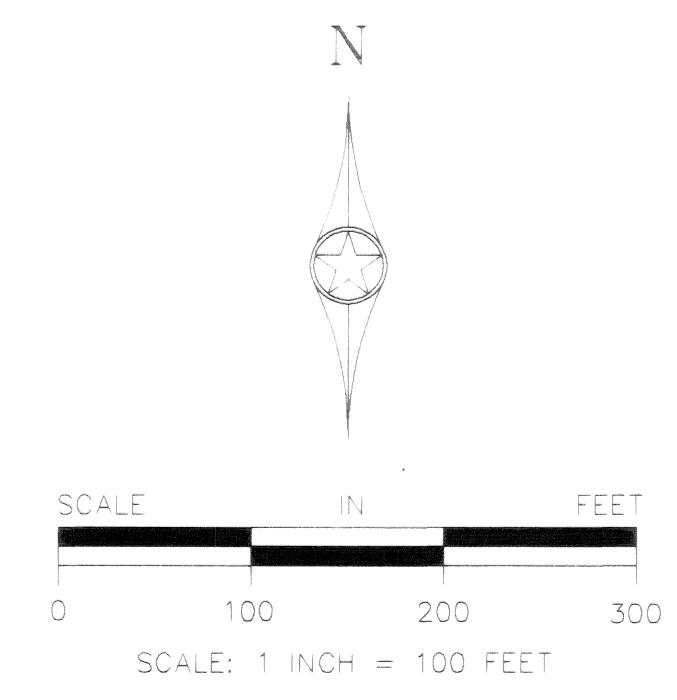
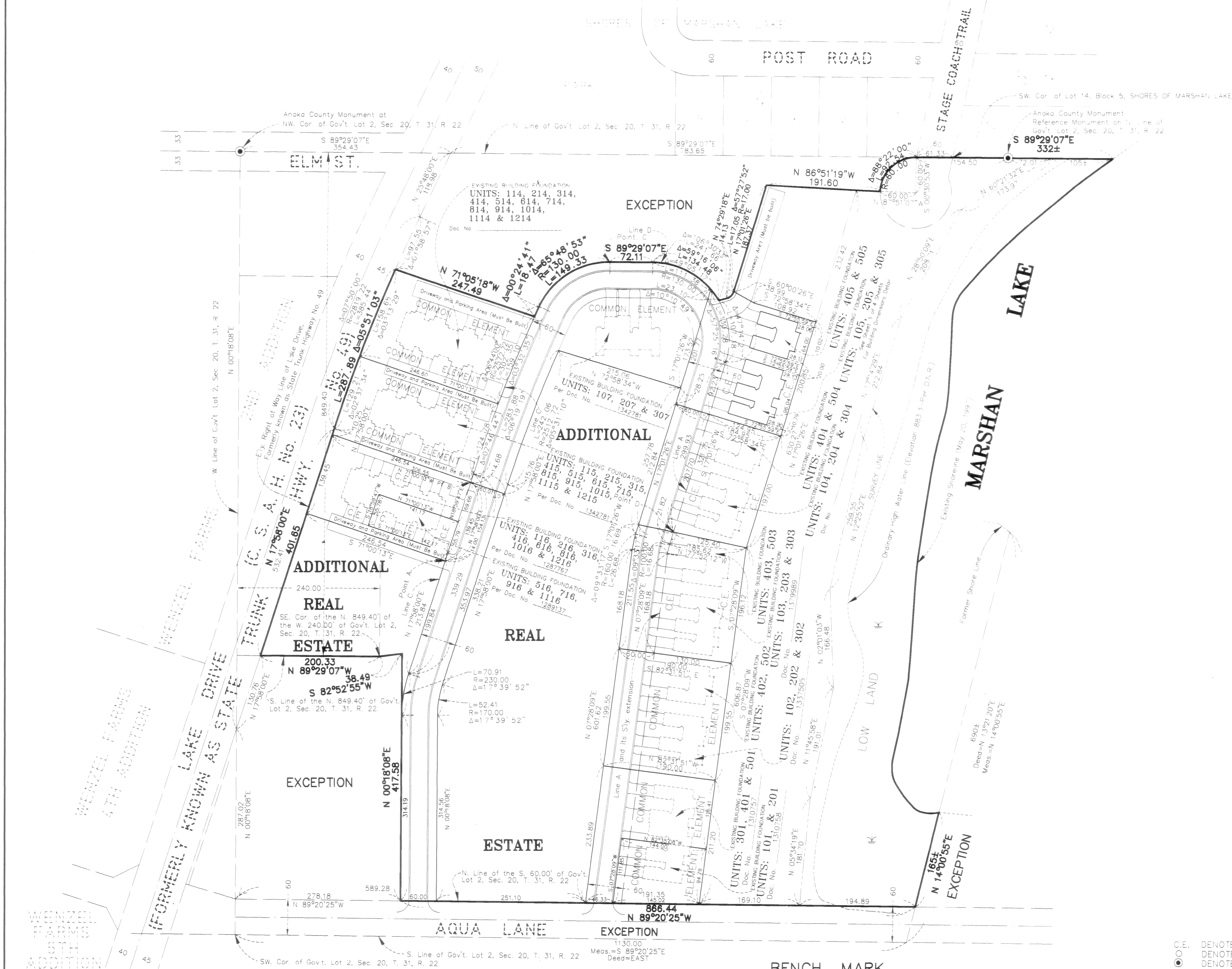

C.E. DENOTES COMMON ELEMENT.
○ DENOTES 1/2 INCH IRON PIPE SET.
● DENOTES ANOKA COUNTY MONUMENT.
NOTE: FOR THE PURPOSES OF THIS PLAT, THE WEST LINE OF GOV'T. LOT 2, SEC. 20, T. 31, R. 22 IS ASSUMED TO BEAR N 00°18'08"E.

CAINE & ASSOCIATES
LAND SURVEYORS, INC.

CIC NUMBER 27

MARSHAN LAKE CONDOMINIUMS, A COMMON INTEREST COMMUNITY NINTH SUPPLEMENTAL CIC PLAT AS - BUILT

C O M M O N

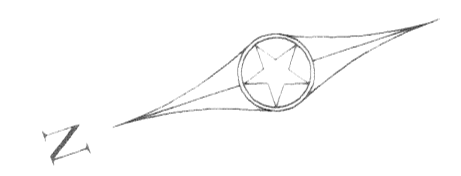
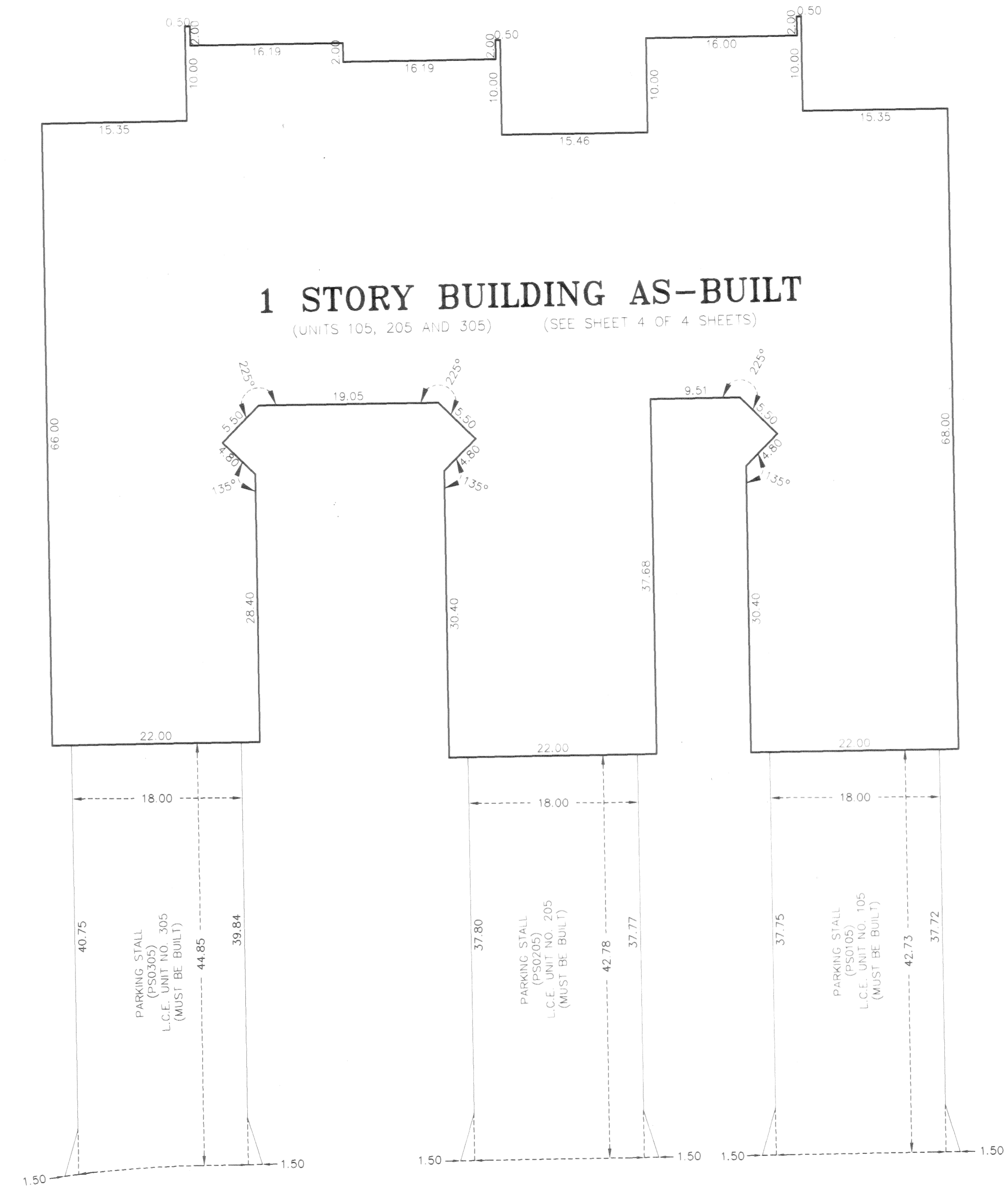
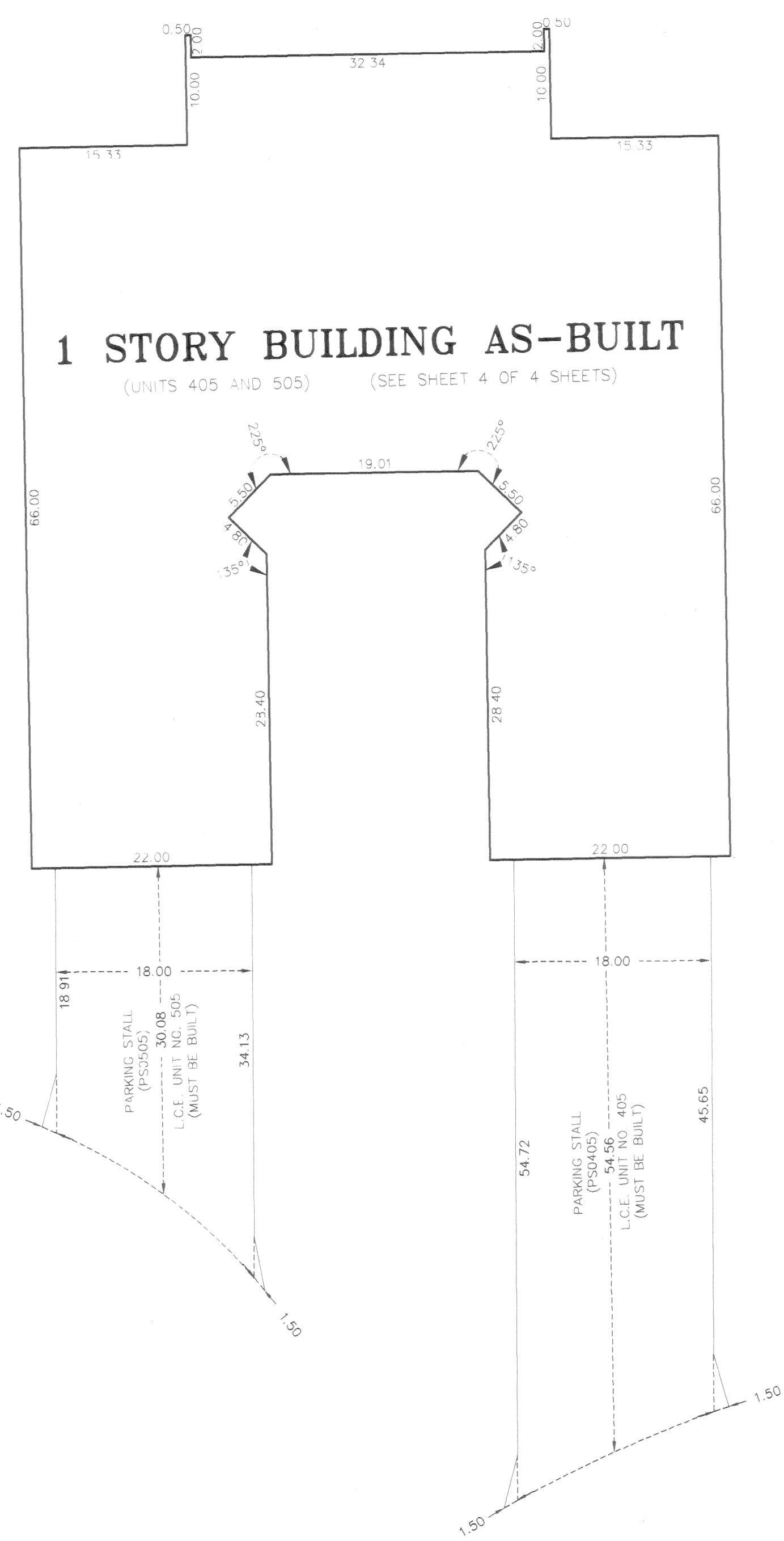

E L E M E N T

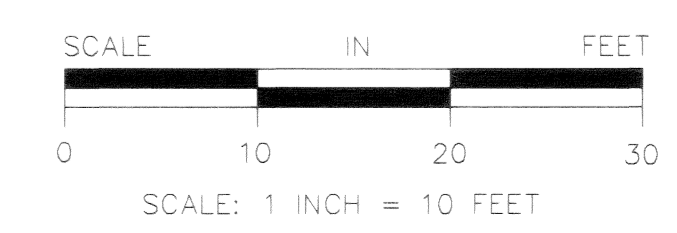

CAINE & ASSOCIATES
LAND SURVEYORS, INC.

CIC NUMBER 27

MARSHAN LAKE CONDOMINIUMS, A COMMON INTEREST COMMUNITY

NINTH SUPPLEMENTAL CIC PLAT

FLOOR PLAN

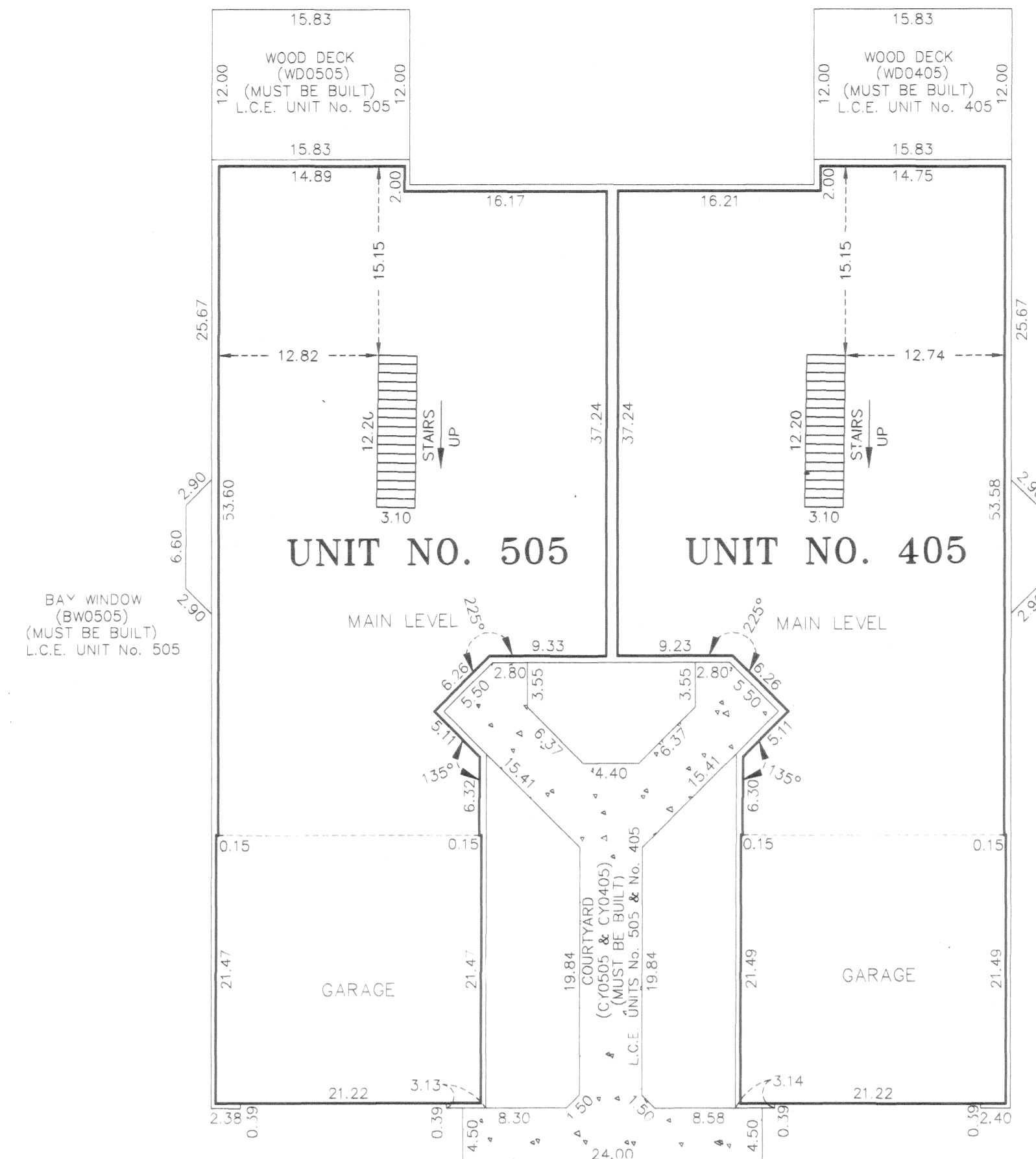

BAY WINDOW (BW0505) (MUST BE BUILT) L.C.E. UNIT No. 505

BAY WINDOW (BW0405) (MUST BE BUILT) L.C.E. UNIT No. 405

MAIN LEVEL

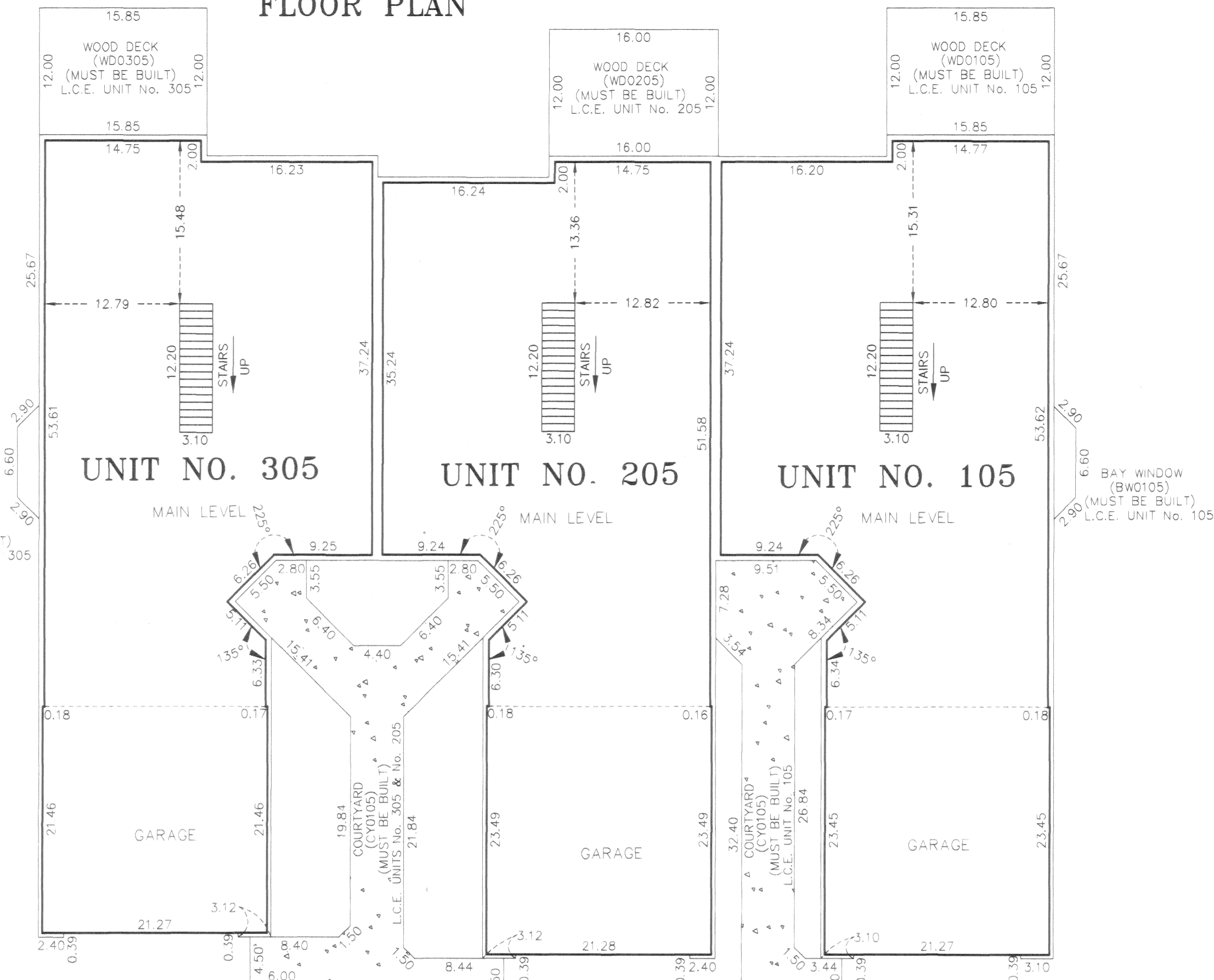

BAY WINDOW (BW0105) (MUST BE BUILT) L.C.E. UNIT No. 105

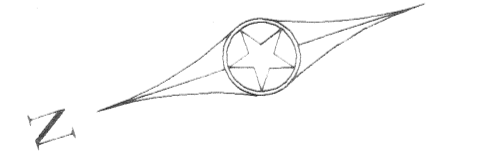
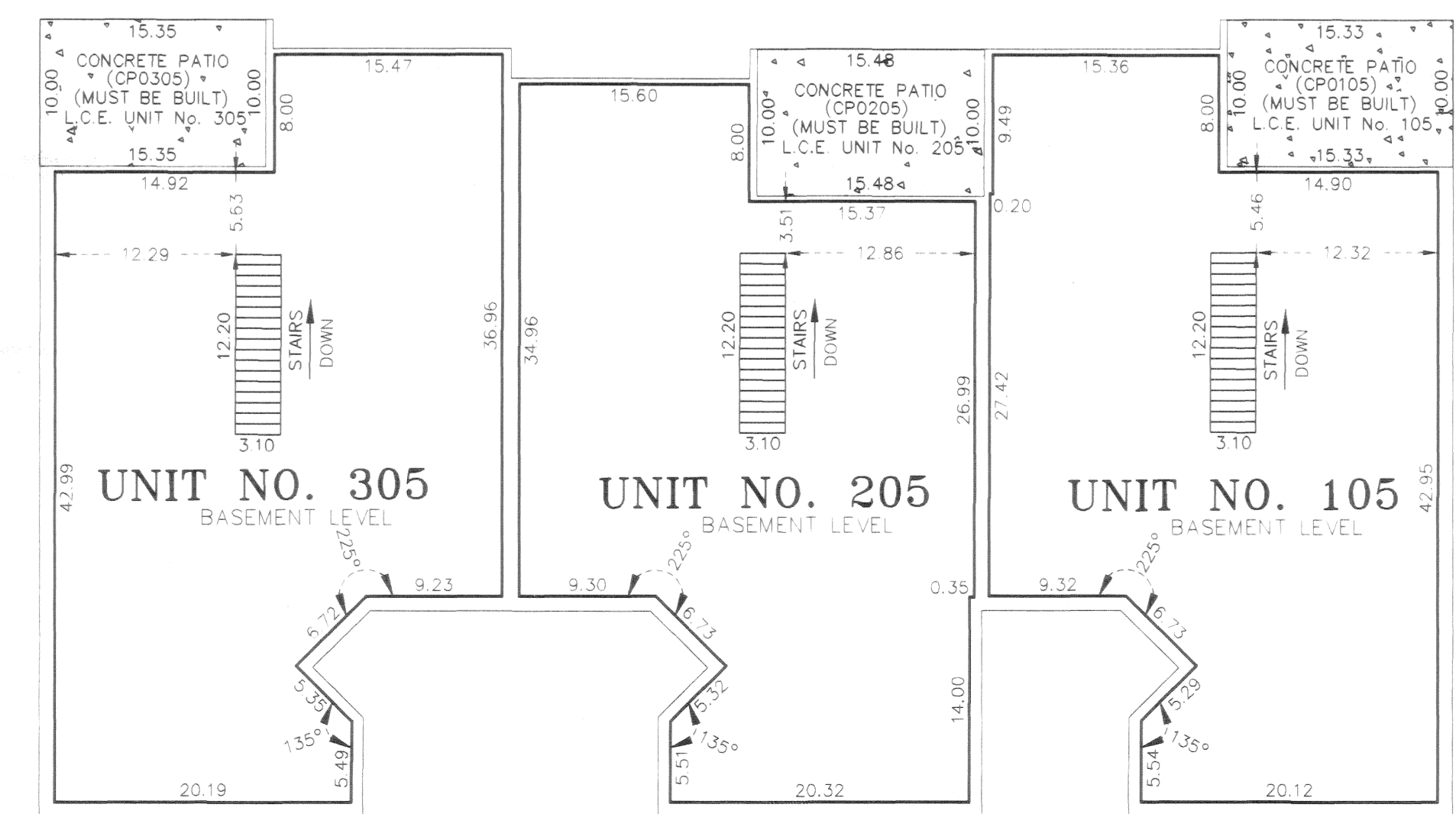
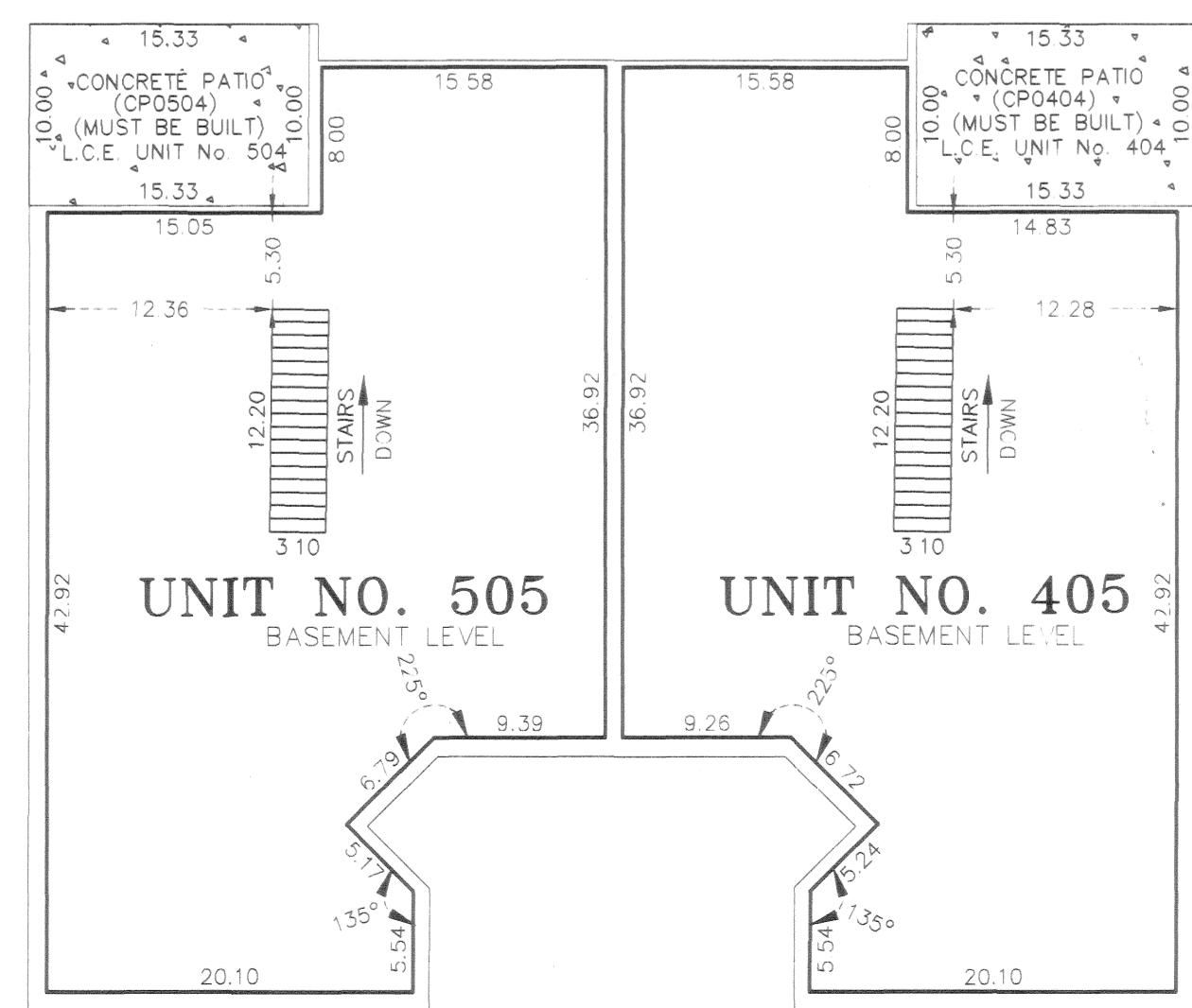
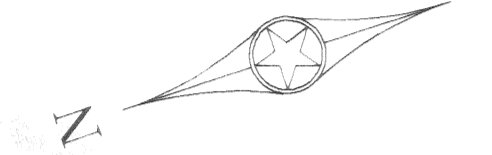

BASEMENT LEVEL

All main level floor elevations vary from 901.90 feet to 902.16 feet.
 All main level ceiling elevations vary from 911.05 feet to 916.20 feet.
 All basement level floor elevations vary from 892.20 feet to 892.40 feet.
 All basement level ceiling elevations vary from 901.91 feet to 902.11 feet.
 All garage floor elevations vary from 901.70 feet to 901.90 feet.

Interior dimensions shown are measured to the unfinished surface of the walls, floors and ceilings.

L.C.E. Denotes Limited Common Element

Elevations are referred to Benchmark as noted on site plan and are shown in feet and hundredths of a foot.

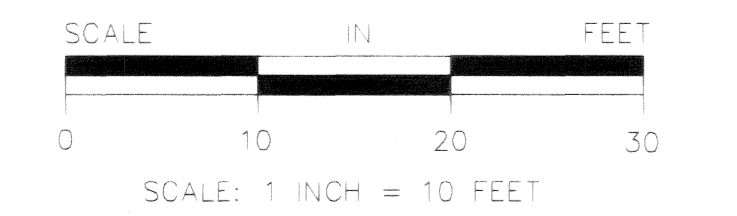

CAINE & ASSOCIATES
LAND SURVEYORS, INC.