

FLINTWOOD ADDITION

CITY OF COON RAPIDS

ANOKA COUNTY, MINNESOTA

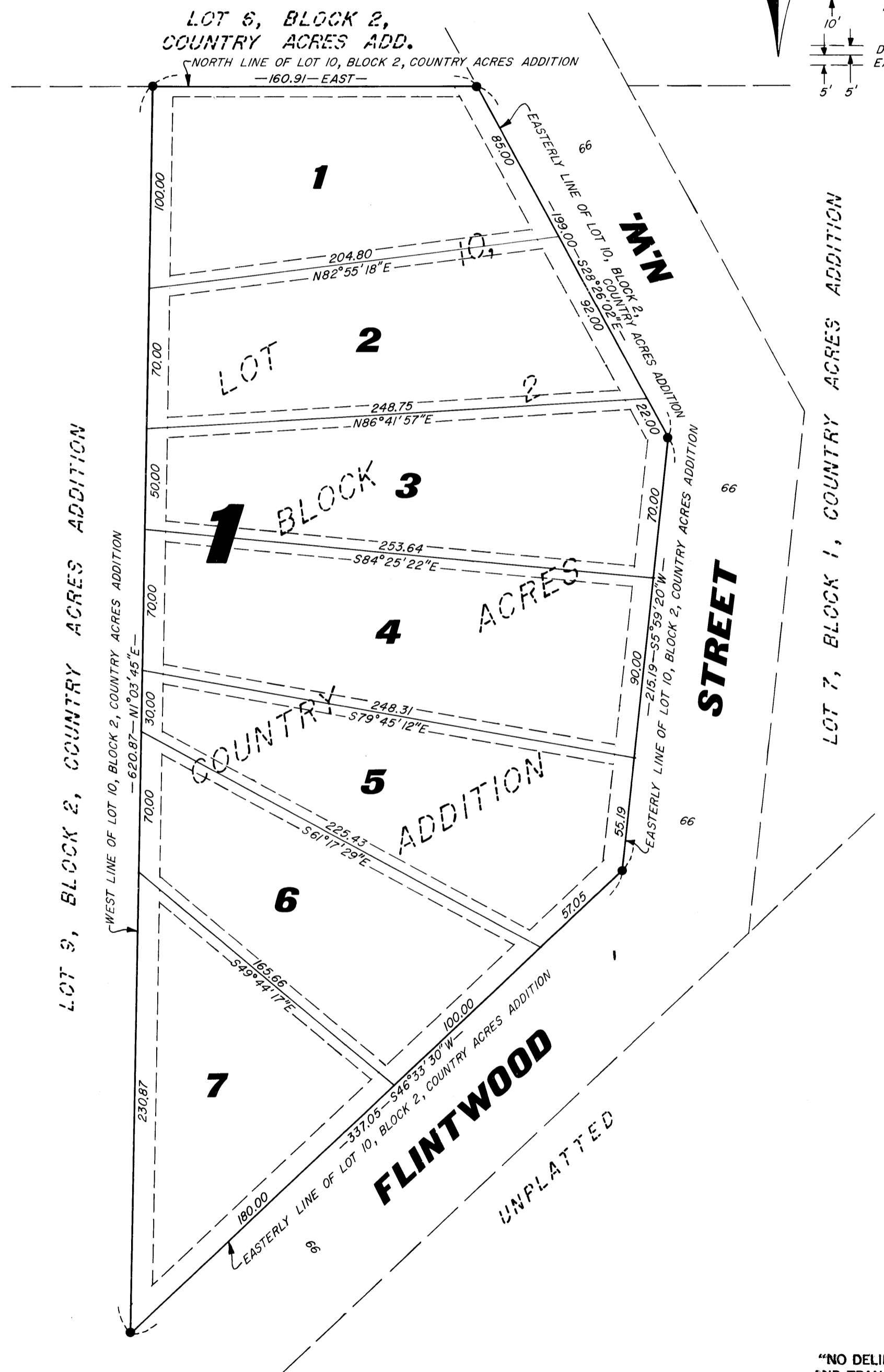
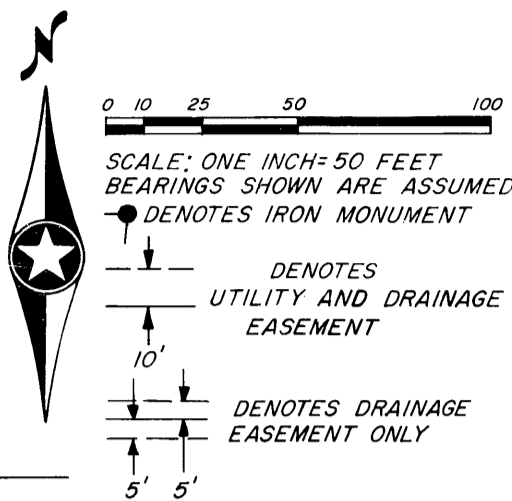

KNOW ALL MEN BY THESE PRESENTS: THAT, NORMAN D. HOLM, SINGLE, OWNER AND PROPRIETOR OF THE FOLLOWING DESCRIBED PROPERTY SITUATED IN THE STATE OF MINNESOTA AND COUNTY OF ANOKA, TO-WIT: LOT 10, BLOCK 2, COUNTRY ACRES ADDITION, ANOKA COUNTY, MINNESOTA,

HAVE CAUSED THE SAME TO BE SURVEYED AND PLATTED AS FLINTWOOD ADDITION AND DO HEREBY DEDICATE THE UTILITY AND DRAINAGE EASEMENTS AS SHOWN ON THE PLAT. IN WITNESS WHEREOF SAID NORMAN D. HOLM, HAS HEREUNTO SET HIS HAND AND SEAL ON THIS 10th DAY OF Feb A.D., 1977.

SIGNED:
Norman D. Holm
NORMAN D. HOLM

STATE OF MINNESOTA)
COUNTY OF ANOKA)⁵⁵
SINGLE, THE FOREGOING INSTRUMENT WAS ACKNOWLEDGED BEFORE ME THIS 10th DAY OF Feb A.D., 1977 BY NORMAN D. HOLM,

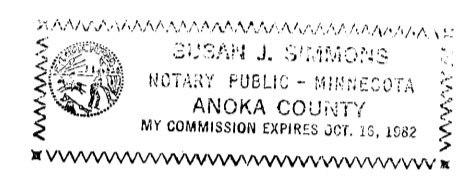

Susan J. Simons
NOTARY PUBLIC, ANOKA COUNTY, MINNESOTA

I HEREBY CERTIFY THAT I HAVE SURVEYED AND PLATTED THE LAND DESCRIBED IN THE DEDICATION ON THE PLAT AS FLINTWOOD ADDITION; THAT THE PLAT IS A CORRECT REPRESENTATION OF SAID SURVEY; THAT ALL DISTANCES ARE CORRECTLY SHOWN ON SAID PLAT IN FEET AND HUNDREDTHS OF A FOOT; THAT THE MONUMENTS HAVE BEEN CORRECTLY PLACED IN THE GROUND AS SHOWN; THAT THE OUTSIDE BOUNDARIES ARE CORRECTLY DESIGNATED ON SAID PLAT, AND THAT THERE ARE NO WET LANDS OR PUBLIC HIGHWAYS TO BE DESIGNATED ON SAID PLAT OTHER THAN ARE SHOWN THEREON.

M. C. Hoium
REGISTERED LAND SURVEYOR - MINNESOTA REGISTRATION NO. 4427

STATE OF MINNESOTA)
COUNTY OF ANOKA)⁵⁵
ON THIS 17th DAY OF JANUARY A.D., 1977

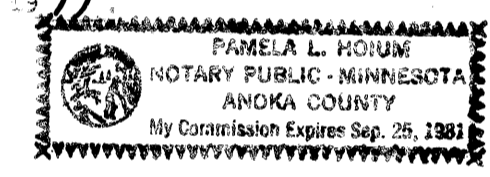

Pamela L. Hoium
NOTARY PUBLIC, ANOKA COUNTY, MINNESOTA

THE ANNEXED PLAT OF FLINTWOOD ADDITION WAS APPROVED BY THE PLANNING AND ZONING COMMISSION OF THE CITY OF COON RAPIDS, ANOKA COUNTY, MINNESOTA AT A REGULAR MEETING THEREOF HELD THIS 10th DAY OF September A.D., 1975.

BY Donald Olson CHAIRMAN BY William J. McLean Jr SECRETARY

WE HEREBY CERTIFY THAT THE CITY COUNCIL OF THE CITY OF COON RAPIDS, ANOKA COUNTY, MINNESOTA, DULY ACCEPTED AND APPROVED THE ANNEXED PLAT OF FLINTWOOD ADDITION AT A REGULAR MEETING THEREOF HELD THIS 8th DAY OF March A.D., 1977.

BY George J. Lubitz MAYOR BY Betty Bell CLERK

CHECKED AND APPROVED THIS 14th DAY OF April A.D., 1977.

Roland W. Anderson
COUNTY SURVEYOR, ANOKA COUNTY, MINNESOTA

466105
OFFICE OF COUNTY RECORDER
STATE OF MINNESOTA, COUNTY OF ANOKA
I hereby certify that the within instrument was filed in this office for record on the 14th DAY OF April A.D., 1977 at 9 o'clock A.M., and was duly recorded in book 22 of Plat 2, page 19.

Fred J. Comdehl
County Recorder
By G. L. Halderman
Deputy

"NO DELINQUENT TAXES AND TRANSFER ENTERED"
April 14, 1977
Charles R. Lohman
Auditor, Anoka County
BY J. Olson
Deputy