

# GREENLAND HILLS

## TOWNSHIP OF RAMSEY

### ANOKA COUNTY, MINNESOTA

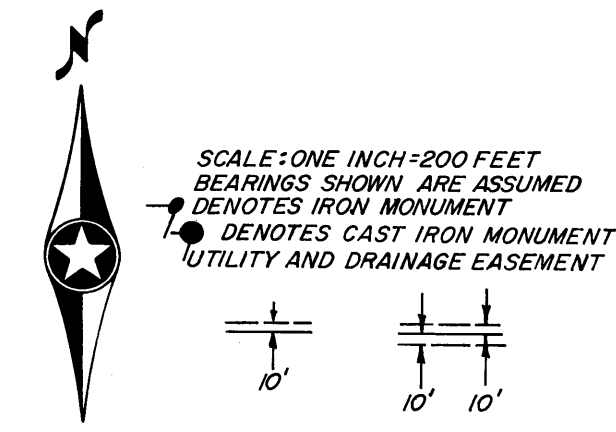

OFFICE OF REGISTER OF DEEDS  
STATE OF MINNESOTA, COUNTY OF ANOKA

I hereby certify that the within instrument was filed in this office for record on the 5th day of April, A.D. 1972, at 4 o'clock P.M., and was duly recorded in book 2 of Plat, page 16.

Fred J. Omdahl  
Register of Deeds

Margaret K. Kelleher  
Deputy

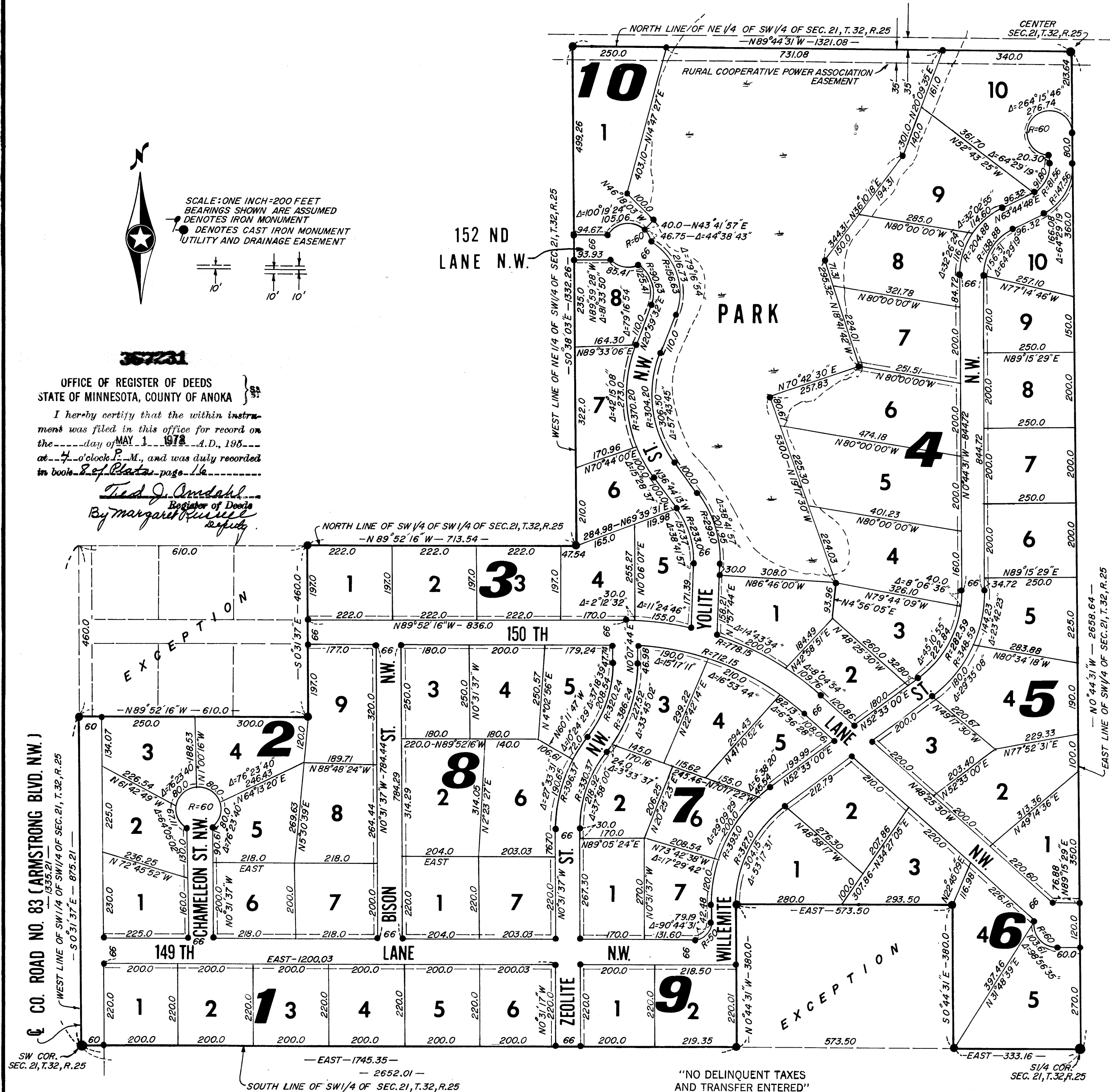

**N.C. HOIUM & ASSOCIATES, INC.**  
Engineers-Surveyors

KNOW ALL MEN BY THESE PRESENTS: THAT, A & R DEVELOPMENT, INC., A MINNESOTA CORPORATION, OWNERS AND PROPRIETORS, AND ALBINA SANDY, A WIDOW, MORTGAGEE, OF THE FOLLOWING DESCRIBED PROPERTY SITUATED IN THE COUNTY OF ANOKA AND STATE OF MINNESOTA TO-WIT: THE NORTHEAST 1/4 OF THE SOUTHWEST 1/4 AND THE SOUTHWEST 1/4 OF THE SOUTHWEST 1/4 EXCEPT THE WEST 573.5 FEET OF THE EAST 906.66 FEET OF THE SOUTH 380 FEET, AS MEASURED ALONG THE SOUTH AND EAST LINES OF SAID SOUTHWEST 1/4 OF THE SOUTHWEST 1/4, AND THE SOUTHWEST 1/4 OF THE SOUTHWEST 1/4 EXCEPT THE WEST 610 FEET OF THE NORTH 460 FEET, AS MEASURED ALONG THE NORTH AND WEST LINES OF SAID SOUTHWEST 1/4 OF THE SOUTHWEST 1/4, ALL IN SECTION 21, TOWNSHIP 32, RANGE 25. SUBJECT TO EASEMENT OF RECORD TO RURAL COOPERATIVE POWER ASSOCIATION.

HAVE CAUSED THE SAME TO BE SURVEYED AND PLATTED AS GREENLAND HILLS AND DO HEREBY DONATE AND DEDICATE TO THE PUBLIC FOR PUBLIC USE FOREVER THE BOULEVARD, LANES, PARK AND STREETS AS SHOWN ON THE PLAT. ALSO DEDICATING UTILITY AND DRAINAGE EASEMENTS AS SHOWN ON THE PLAT. IN WITNESS WHEREOF SAID ALBINA SANDY, A WIDOW, HAS HEREUNTO SET HER HAND AND SEAL ON THIS 5th DAY OF April, A.D. 1972. ALSO A & R DEVELOPMENT, INC., HAS CAUSED THESE PRESENTS TO BE SIGNED BY ITS PROPER OFFICERS AND ITS CORPORATE SEAL TO BE HEREUNTO AFFIXED ON THIS 4th DAY OF April, A.D. 1972.

IN THE PRESENCE OF:  
E.P. Babcock AND Margaret J. Sabrowsky  
Albina Sandy  
ALBINA SANDY  
A & R DEVELOPMENT, INC.  
BY Albert R. Bullick PRESIDENT  
BY Ralph D. Williams, Jr. VICE-PRESIDENT

STATE OF MINNESOTA )  
COUNTY OF HENNEPIN ) ss  
ON THIS 5th DAY OF April, A.D. 1972, BEFORE ME, A NOTARY PUBLIC WITHIN AND FOR SAID COUNTY AND STATE, PERSONALLY APPEARED ALBINA SANDY, A WIDOW, TO ME PERSONALLY KNOWN TO BE THE PERSON DESCRIBED IN AND WHO EXECUTED THE FOREGOING INSTRUMENT AND SHE AFFIRMS AND ACKNOWLEDGES THE SAME AS HER OWN FREE ACT AND DEED.  
MY COMMISSION EXPIRES June 5, 1977

E.P. Babcock  
NOTARY PUBLIC, HENNEPIN COUNTY, MINNESOTA

STATE OF MINNESOTA )  
COUNTY OF ANOKA ) ss  
ON THIS 4th DAY OF April, A.D. 1972, BEFORE ME, A NOTARY PUBLIC WITHIN AND FOR SAID COUNTY AND STATE, PERSONALLY APPEARED ALBERT R. BULLICK AND RALPH D. WILLIAMS, JR., TO ME PERSONALLY KNOWN, WHO BEING BY ME DULY SWORN, DID SAY THAT THEY ARE THE PRESIDENT AND VICE-PRESIDENT, RESPECTIVELY, OF A & R DEVELOPMENT, INC., THE CORPORATION NAMED IN THE FOREGOING INSTRUMENT; THAT THE SEAL AFFIXED TO SAID INSTRUMENT IS THE CORPORATE SEAL OF SAID CORPORATION; AND THAT SAID INSTRUMENT WAS SIGNED AND SEALED IN BEHALF OF SAID CORPORATION BY AUTHORITY OF ITS BOARD OF DIRECTORS, AND SAID ALBERT R. BULLICK AND RALPH D. WILLIAMS, JR., ACKNOWLEDGED SAID INSTRUMENT TO BE THE FREE ACT AND DEED OF SAID CORPORATION.  
MY COMMISSION EXPIRES Dec. 5, 1976

Doretta M. Hoium  
NOTARY PUBLIC, ANOKA COUNTY, MINNESOTA

I HEREBY CERTIFY THAT I HAVE SURVEYED AND PLATTED THE LAND DESCRIBED IN THE DEDICATION ON THIS PLAT AS GREENLAND HILLS; THAT THIS PLAT IS A CORRECT REPRESENTATION OF SAID SURVEY; THAT ALL DISTANCES ARE CORRECTLY SHOWN ON SAID PLAT; THAT ALL MONUMENTS HAVE BEEN CORRECTLY PLACED IN THE GROUND AS SHOWN; AND THAT THE OUTSIDE BOUNDARIES OF THE LAND ARE CORRECTLY DESIGNATED ON SAID PLAT; AND THAT THERE ARE NO WET LANDS OR PUBLIC HIGHWAYS TO BE DESIGNED OTHER THAN ARE SHOWN THEREON.

N. C. Hoium  
REGISTERED LAND SURVEYOR - MINN. REG. NO. 4427

STATE OF MINNESOTA )  
COUNTY OF ANOKA ) ss  
ON THIS 6th DAY OF March, A.D. 1972, BEFORE ME, A NOTARY PUBLIC WITHIN AND FOR SAID COUNTY AND STATE, SURVEYOR'S CERTIFICATE SUBSCRIBED AND SWORN TO BEFORE ME, A NOTARY PUBLIC WITHIN AND FOR SAID COUNTY AND STATE  
MY COMMISSION EXPIRES 6-23-77

Gail E. Schuette  
NOTARY PUBLIC, ANOKA COUNTY, MINN.  
My Commission Expires June 23, 1977.

RECOMMENDED FOR APPROVAL THIS 25th DAY OF April, A.D. 1972

Hail E. Schuette  
NOTARY PUBLIC, ANOKA COUNTY, MINNESOTA

E. J. Lundheim  
ANOKA COUNTY HIGHWAY ENGINEER

THIS PLAT WAS APPROVED AS TO FORM AND EXECUTION ON THIS 1st DAY OF May, A.D. 1972.

Robert W. Johnson  
COUNTY ATTORNEY, ANOKA COUNTY, MINNESOTA

CHECKED AND APPROVED THIS 25th DAY OF April, A.D. 1972.

Roland W. Anderson  
ANOKA COUNTY SURVEYOR

ANNEXED PLAT OF GREENLAND HILLS WAS APPROVED BY THE TOWN BOARD OF THE TOWNSHIP OF RAMSEY AT A REGULAR MEETING THEREOF HELD THIS 20th DAY OF March, A.D. 1972.

Helmut E. Murphy  
CHAIRMAN  
James M. Peterson  
CLERK

THIS PLAT WAS APPROVED AND ACCEPTED BY THE BOARD OF COUNTY COMMISSIONERS OF THE COUNTY OF ANOKA, STATE OF MINNESOTA, AT A REGULAR MEETING THEREOF HELD THIS 25th DAY OF April, A.D. 1972.

Robert A. Ordish  
CHAIRMAN  
Charles P. Seflone  
COUNTY AUDITOR

ANNEXED PLAT OF GREENLAND HILLS WAS APPROVED BY THE PLANNING COMMISSION OF THE TOWNSHIP OF RAMSEY AT A REGULAR MEETING THEREOF HELD THIS 6th DAY OF March, A.D. 1972.

Gary Reinorn  
CHAIRMAN