

HUGHS INDUSTRIAL PARK

CITY OF ANDOVER - COUNTY OF ANOKA

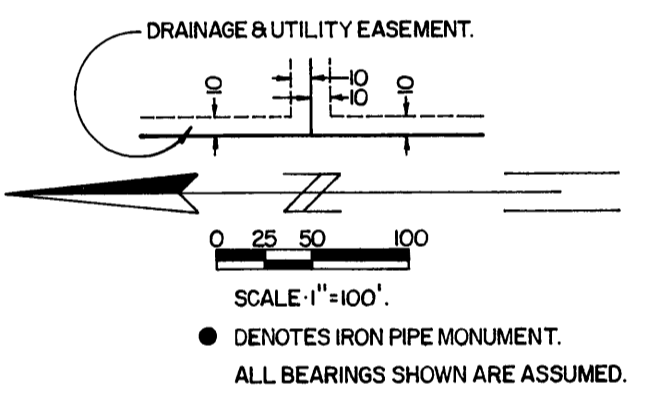
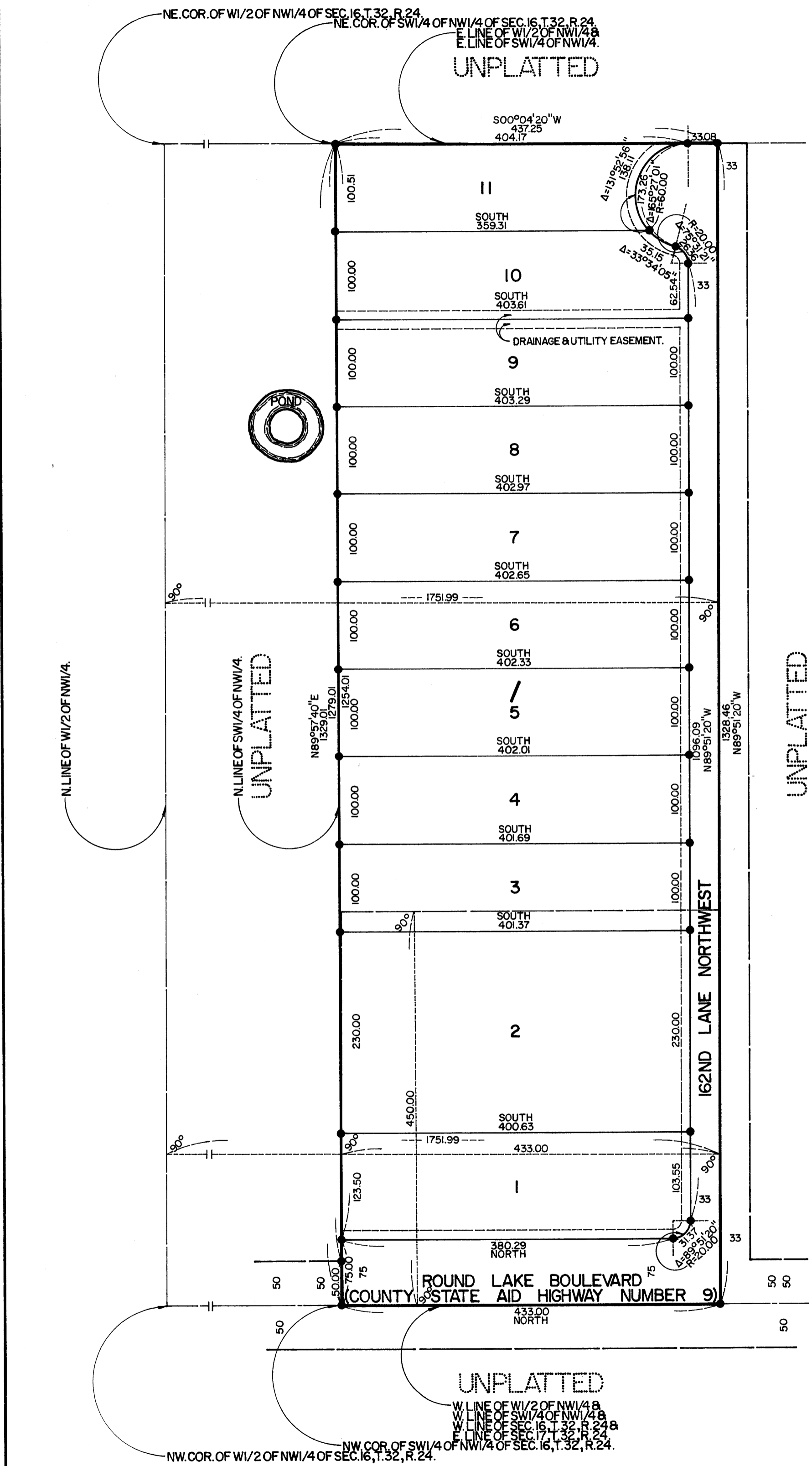

OFFICE OF REGISTER OF DEEDS
 STATE OF MINNESOTA, COUNTY OF ANOKA
 I hereby certify that the within instrument was filed in this office for record on the SEP 11 1975 A.D., 19 3:30 o'clock P.M., and was duly recorded in book 19 of Plats page 2

Del J. Omdahl
 Register of Deeds
 By Virginia L. Halderman Deputy

"NO DELINQUENT TAXES AND TRANSFER ENTERED"

Sept. 11, 1975
Charles R. Johnson
 Auditor, Anoka County
 By Nancy C. Gausman Deputy

Know all men by these presents that Wallace C. Hughs and Eunice M. Hughs, his wife, fee owners of the following described property situated in the County of Anoka, State of Minnesota, to-wit: That part of the SW¹/₄ of the NW¹/₄ of Section 16, Township 32, Range 24 lying North of the South line of the North 1,751.99 feet of the W¹/₂ of the NW¹/₄ of said Section 16; and that First National Bank of Hudson, a Wisconsin Corporation and mortgagee of the West 450 feet of the South 433 feet of the North 1,751.99 feet of the W¹/₂ of the NW¹/₄ of Section 16, Township 32, Range 24. Have caused the same to be surveyed and platted as HUGHS INDUSTRIAL PARK and do hereby donate and dedicate to the public for public use forever the Boulevard, Lane and drainage and utility easements as shown on the annexed plat; also dedicating to the County of Anoka the right of access to County State Aid Highway No. 9 from Lot 1, Block 1 as shown on the plat. In witness whereof said Wallace C. Hughs and Eunice M. Hughs, his wife, have hereunto set their hands and seals this 2nd day of September, 1975 A.D.; and that said First National Bank of Hudson, a Wisconsin Corporation, has caused these presents to be signed by its proper officers, this 9th day of September, 1975 A.D.

Signed:
Wallace C. Hughs
 Wallace C. Hughs
Eunice M. Hughs
 Eunice M. Hughs

By First National Bank of Hudson
 A Wisconsin Corporation
and A. H. Hays, v.p.

STATE OF MINNESOTA } (SS
 COUNTY OF ANOKA }
 On this 2nd day of September, 1975 A.D. before me, a notary public, within and for said County and State, personally appeared Wallace C. Hughs and Eunice M. Hughs, his wife, to me personally known to be the persons described in and who executed the foregoing instrument; and they affirm and acknowledge that they executed the same as their own free act and deed.

Muriel C. Winner
 Notary Public, Anoka County, Minnesota
 My commission expires Oct. 6, 1981

STATE OF WISCONSIN } (SS
 COUNTY OF ST. CROIX }
 On this 9th day of September, 1975 A.D. before me, a Notary Public, within and for said County and State, personally appeared A. E. Dabrowski and C. F. Gray to me personally known, who being by me, each duly sworn, did say that they are, respectively, the Vice-President and Vice-President of First National Bank of Hudson, a Wisconsin Corporation, the corporation named in the foregoing instrument; and that said instrument was signed and sealed in behalf of said corporation by authority of its board of directors and said A. E. Dabrowski and C. F. Gray acknowledge said instrument to be the free act and deed of said corporation.

Mark Edward Laurson
 Notary Public, St. Croix County, Wisconsin
 My commission expires May 22, 1977

I hereby certify that I have surveyed and platted the property described in the dedication of this plat as HUGHS INDUSTRIAL PARK; that this plat is a correct representation of said survey; that all distances are correctly shown on said plat in feet and nearest hundredth of a foot; that all monuments have been correctly placed in the ground as shown on the plat; that the outside boundary lines are correctly designated on the plat; and there are no wet lands or public highways to be designated on said plat other than shown thereon.

Surveyor LeRoy H. Winner
 Minnesota Registration No. 4987

STATE OF MINNESOTA } (SS
 COUNTY OF ANOKA }
 Above certificate subscribed and sworn to before me, a Notary Public, within and for said County and State on this 2nd day of September, 1975 A.D.

Muriel C. Winner
 Notary Public, Anoka County, Minnesota
 My commission expires Oct. 6, 1981

We hereby certify that the City Council of the City of Andover, Minnesota, duly accepted and approved the annexed plat of HUGHS INDUSTRIAL PARK at a regular meeting thereof held this 2nd day of September, 1975 A.D.

Richard W. Schneider Mayor
Richard W. Schneider Clerk

This plat was checked and approved on this 11th day of September, 1975 A.D.

Richard W. Schneider
 County Surveyor, Anoka County, Minnesota

LEROY H. WINNER & ASSOCIATES, INC.
 - LAND SURVEYORS -
 8729 CENTRAL AVENUE NORTHEAST, BLAINE, MINNESOTA 55432