

LEXINGTON MEADOWS 5TH ADDITION

CITY OF BLAINE
COUNTY OF ANOKA
SEC. 23, TWP. 31, RGE. 23

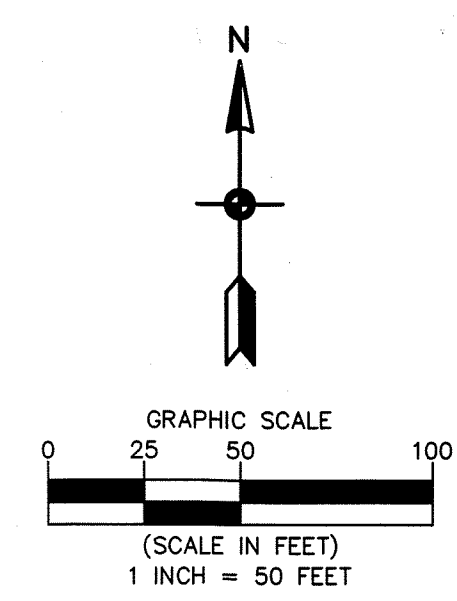
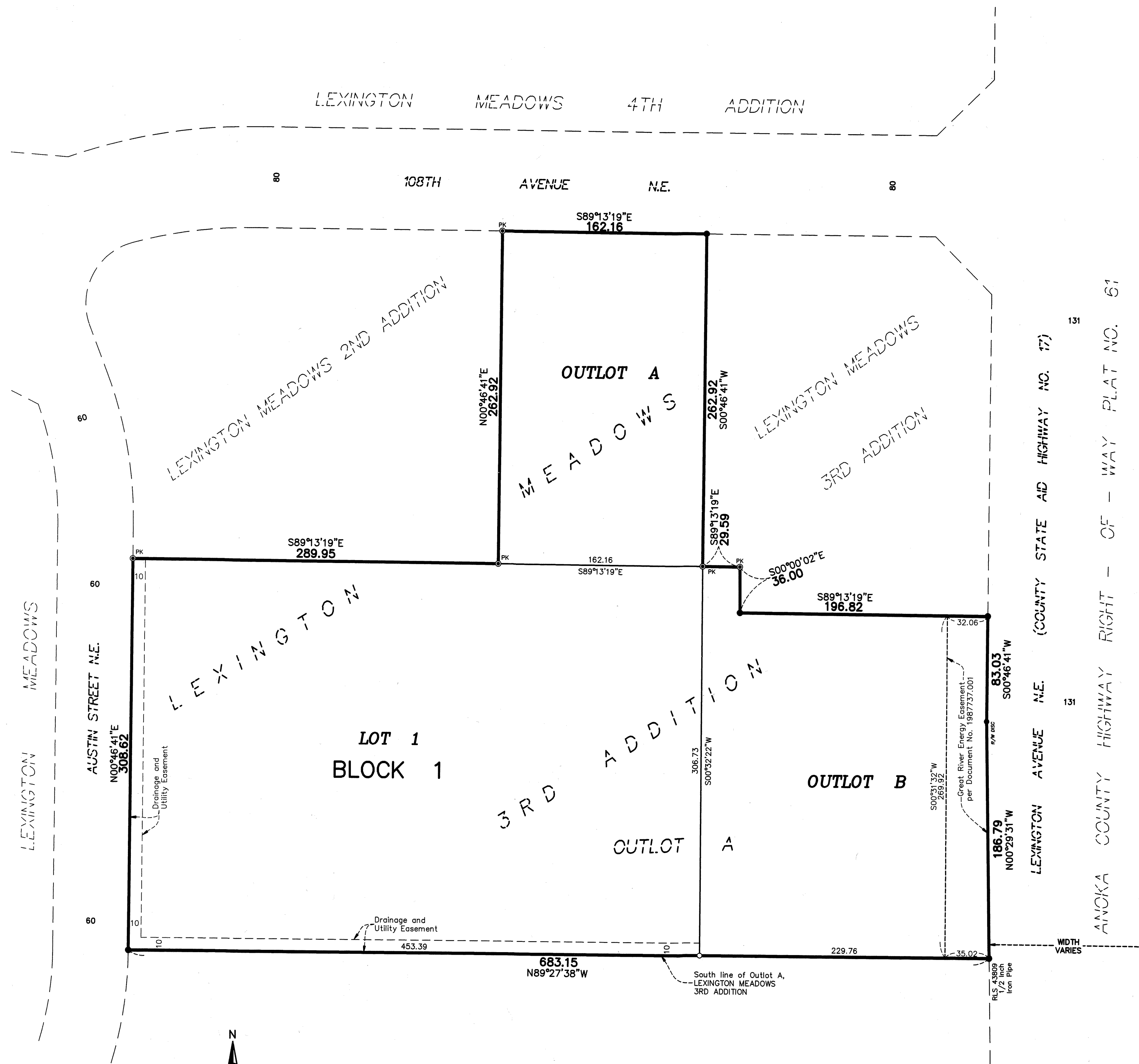

For the purposes of this plat, the South line of Outlot A, LEXINGTON MEADOWS 3RD ADDITION is assumed to have a bearing of North 89 degrees 27 minutes 38 seconds West

○ Denotes 5/8 inch by 14 inch Rebar, set or to be set within one year of recording of this plat and marked with license number 40361

PK ● Denotes set PK Nail

● Denotes Found 5/8 inch by 14 inch Rebar, marked with license number 40361, unless otherwise noted

KNOW ALL PERSONS BY THESE PRESENTS: That Lexington Meadows LLC, a Minnesota limited liability company, owner of the following described property:
Outlot A, LEXINGTON MEADOWS 3RD ADDITION, according to the recorded plat thereof, Anoka County, Minnesota.
Has caused the same to be surveyed and platted as LEXINGTON MEADOWS 5TH ADDITION and does hereby dedicate to the public for public use the drainage and utility easements as shown on this plat.

In witness whereof said Lexington Meadows LLC, a Minnesota limited liability company, has caused these presents to be signed by its proper officer this 12th day of October 12, 2021.

LEXINGTON MEADOWS LLC
By: Stephen B. Wellington, Jr., its Manager
Stephen B. Wellington, Jr.
Stephen B. Wellington, Jr., Chief Manager

STATE OF MINNESOTA
COUNTY OF RAMSEY
This instrument was acknowledged before me on October 12, 2021 by Stephen B. Wellington, Jr., Chief Manager of Wellington Properties LLC, a Minnesota limited liability company, manager of Lexington Meadows LLC, a Minnesota limited liability company.

Beth Huizinga (Signed)
Beth Huizinga (Printed)
Notary Public, State of Minnesota
My commission expires January 31, 2023

I Thomas R. Balluff do hereby certify that this plat was prepared by me or under my direct supervision; that I am a duly Licensed Land Surveyor in the State of Minnesota; that this plat is a correct representation of the boundary survey; that all mathematical data and labels are correctly designated on this plat; that all monuments depicted on this plat have been, or will be correctly set within one year; that all water boundaries and wet lands, as defined in Minnesota Statutes, Section 505.01, Subd. 3, as of the date of this certificate are shown and labeled on this plat; and all public ways are shown and labeled on this plat.
Dated this 8th day of OCTOBER, 2021.

Thomas R. Balluff
Thomas R. Balluff, Licensed Land Surveyor
Minnesota License No. 40361

STATE OF Minnesota
COUNTY OF Anoka
This instrument was acknowledged before me on October 8, 2021 by Thomas R. Balluff.

Kelly Frette (Signed)
Kelly Frette (Printed)
Notary Public, State of Minnesota
My commission expires January 31, 2025

CITY COUNCIL, CITY OF BLAINE, MINNESOTA
This plat of LEXINGTON MEADOWS 5TH ADDITION was approved and accepted by the City Council of the City of Blaine, Minnesota at a regular meeting thereof held this 14th day of June, 2021 and said plat is in compliance with the provisions of Minnesota Statutes, Section 505.03, Subd. 2.

CITY COUNCIL, CITY OF BLAINE, MINNESOTA
By: Paul Jal Mayor
By: Calvin J. ... Clerk

COUNTY SURVEYOR
I hereby certify that in accordance with Minnesota Statutes, Section 505.021, Subd. 11, this plat has been reviewed and approved this 20th day of October, 2021.

By: David M. Ziegler
David M. Ziegler
Anoka County Surveyor

COUNTY AUDITOR/TREASURER
Pursuant to Minnesota Statutes, Section 505.021, Subd. 9, taxes payable in the year 2021 on the land hereinbefore described have been paid. Also, pursuant to Minnesota Statutes, Section 272.12, there are no delinquent taxes and transfer entered this 20th day of October, 2021.

Pamela J LeBlanc
Property Tax Administrator
By: Deborah A. Wolf, Deputy

COUNTY RECORDER/REGISTRAR OF TITLES
County of Anoka, State of Minnesota
I hereby certify that this plat of LEXINGTON MEADOWS 5TH ADDITION was filed in the office of the County Recorder/Registrar of Titles for public record on this 20th day of October, 2021, at 10:38 o'clock A.M. and was duly recorded as Document Number 2341593.003.

Pamela J LeBlanc
County Recorder/Registrar of Titles
By: Deborah A. Wolf, Deputy

\$56.00

