

NOBERG TOWNHOMES

CITY OF COON RAPIDS
COUNTY OF ANOKA
SEC. 16, TWP. 31, RGE. 24

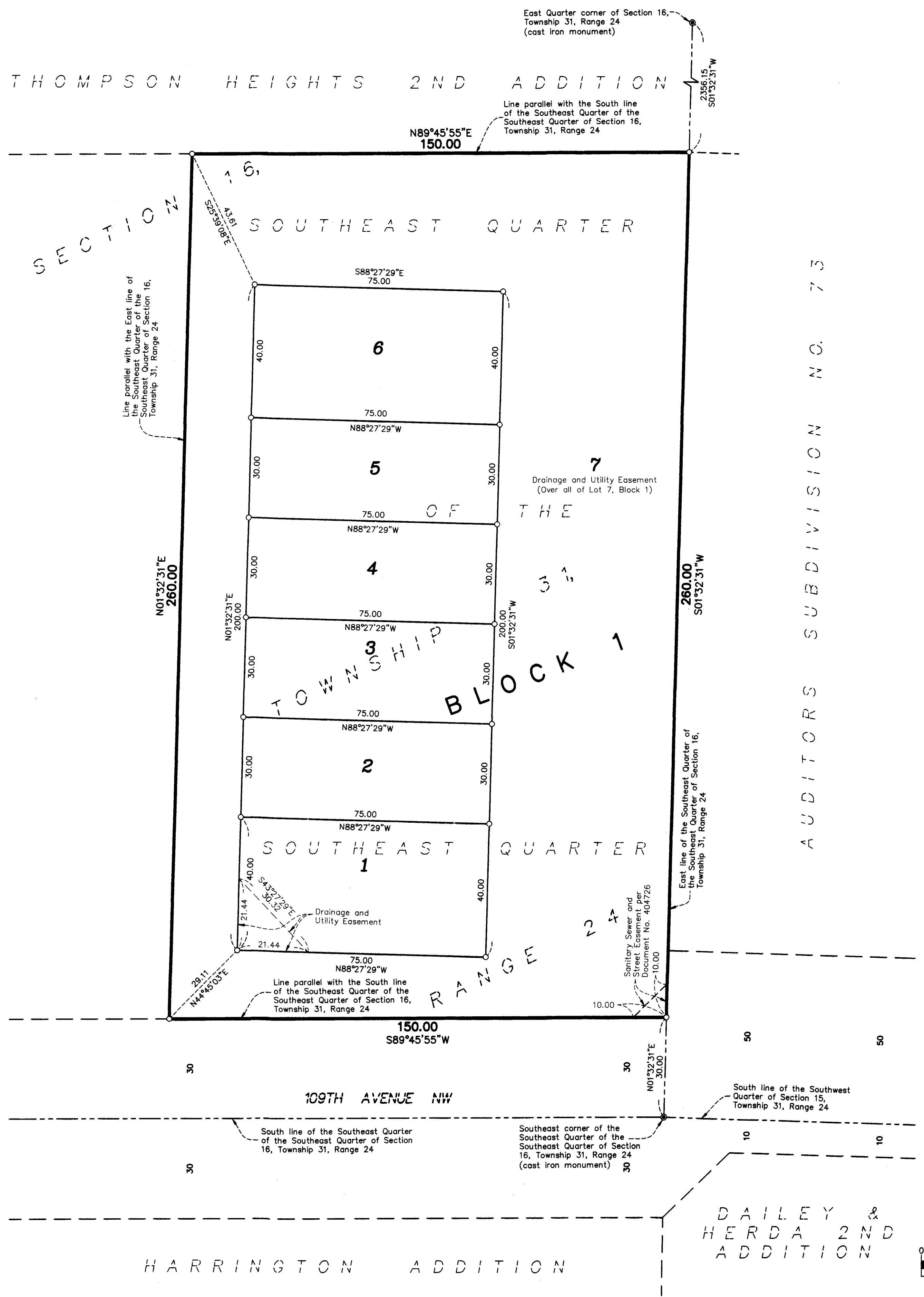

KNOW ALL PERSONS BY THESE PRESENTS: That Noberg Homes, Inc., a Minnesota corporation, owner of the following described property:

That part of the Southeast Quarter of the Southeast Quarter of Section 16, Township 31, Range 24, Anoka County, Minnesota, described as follows:

Commencing at the Southeast corner of said Section 16, and proceeding thence North on the East line of said Section 16 for a distance of 30 feet and to the point of commencement of the tract to be described herein and proceeding thence West and parallel to the South line of said Section 16 for a distance of 150 feet and proceeding thence North and parallel to the East line of said Section 16 for a distance of 260 feet and proceeding thence East and parallel to the South line of said Section 16 for a distance of 150 feet to the East line of said Section 16 and proceeding thence South on said East line to the point of commencement herein.

Has caused the same to be surveyed and platted as NOBERG TOWNHOMES and does hereby dedicate to the public for public use the drainage and utility easements as shown on this plat.

In witness whereof said Noberg Homes, Inc., a Minnesota corporation, has caused these presents to be signed by its proper officer this 29th day of October, 2020

NOBERG HOMES, INC.

Wade M. Tollefson, President

STATE OF Minnesota
COUNTY OF Anoka

This instrument was acknowledged before me on October 29, 2020 by Wade M. Tollefson, President of Noberg Homes, Inc., a Minnesota corporation, on behalf of the corporation.

J. Moehlmann (Signed)
Jennifer Moehlmann (Printed)
Notary Public, Milk Lake County, Minnesota
My commission expires January 31, 2024

I, Thomas R. Balluff do hereby certify that this plat was prepared by me or under my direct supervision; that I am a duly Licensed Land Surveyor in the State of Minnesota; that this plat is a correct representation of the boundary survey; that all mathematical data and labels are correctly designated on this plat; that all monuments depicted on this plat have been, or will be correctly set within one year; that all water boundaries and wet lands, as defined in Minnesota Statutes, Section 505.01, Subd. 3, as of the date of this certificate are shown and labeled on this plat; and all public ways are shown and labeled on this plat.

Thomas R. Balluff
Thomas R. Balluff, Licensed Land Surveyor
Minnesota License No. 40361

STATE OF Minnesota
COUNTY OF Anoka

This instrument was acknowledged before me on September 25, 2020 by Thomas R. Balluff.

Cynthia J. Morica (Signed)
Cynthia J. Morica (Printed)
Notary Public, Hennepin County, Minnesota
My commission expires January 31, 2025

CITY COUNCIL, CITY OF COON RAPIDS, MINNESOTA

This plat of NOBERG TOWNHOMES was approved and accepted by the City Council of the City of Coon Rapids, Minnesota at a regular meeting thereof held this 4th day of August, 2020 and said plat is in compliance with the provisions of Minnesota Statutes, Section 505.03, Subd. 2.

CITY COUNCIL, CITY OF COON RAPIDS, MINNESOTA

By: Jon Koel Mayor
By: Jean Lemmings Clerk

COON RAPIDS PLANNING COMMISSION

Be it known that at a meeting held on this 16th day of July, 2020, the Planning Commission of the City of Coon Rapids, Minnesota, did hereby review and approve this plat of NOBERG TOWNHOMES.

PLANNING COMMISSION, CITY OF COON RAPIDS, MINNESOTA

By: Wayne Schwartz Chairperson

COUNTY SURVEYOR

I hereby certify that in accordance with Minnesota Statutes, Section 505.021, Subd. 11, this plat has been reviewed and approved this 14th day of December, 2020

Charles F. Gitzen
Charles F. Gitzen
Anoka County Surveyor

COUNTY AUDITOR/TREASURER

Pursuant to Minnesota Statutes, Section 505.021, Subd. 9, taxes payable in the year 2020 on the land hereinbefore described have been paid. Also, pursuant to Minnesota Statutes, Section 272.12, there are no delinquent taxes and transfer entered this 14th day of December, 2020.

Pamela J LeBlanc
Property Tax Administrator
By: Rose A Tendoh Deputy

COUNTY RECORDER/REGISTRAR OF TITLES

County of Anoka, State of Minnesota

I hereby certify that this plat of NOBERG TOWNHOMES was filed in the office of the County Recorder/Registrar of Titles for public record on this 14th day of December, 2020 at 12:16 o'clock P.M. and was duly recorded as Document Number 2293248.003

Pamela J LeBlanc
County Recorder/Registrar of Titles
By: Rose A Tendoh Deputy

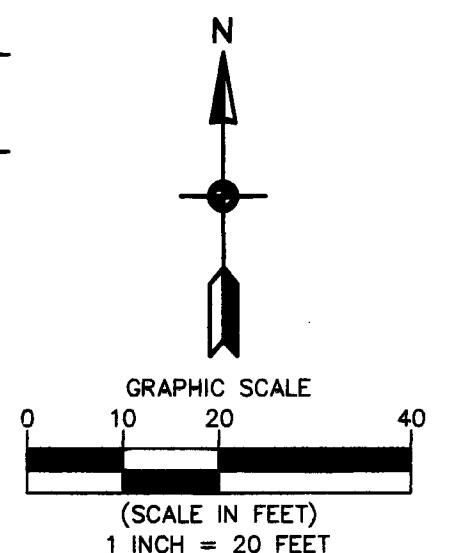

For the purposes of this plat, the East line of the Southeast Quarter of the Southeast Quarter of Section 16, Township 31, Range 24 is assumed to have a bearing of South 01 degrees 32 minutes 31 seconds West.

- Denotes 5/8 inch by 14 inch Rebar, set or to be set within one year of recording of this plat and marked with license number 40361
- Denotes Found Anoka County Cast Iron Section Monument

\$56.00

