

PANKONIN ADDITION

CITY OF ANDOVER

ANOKA COUNTY, MINNESOTA

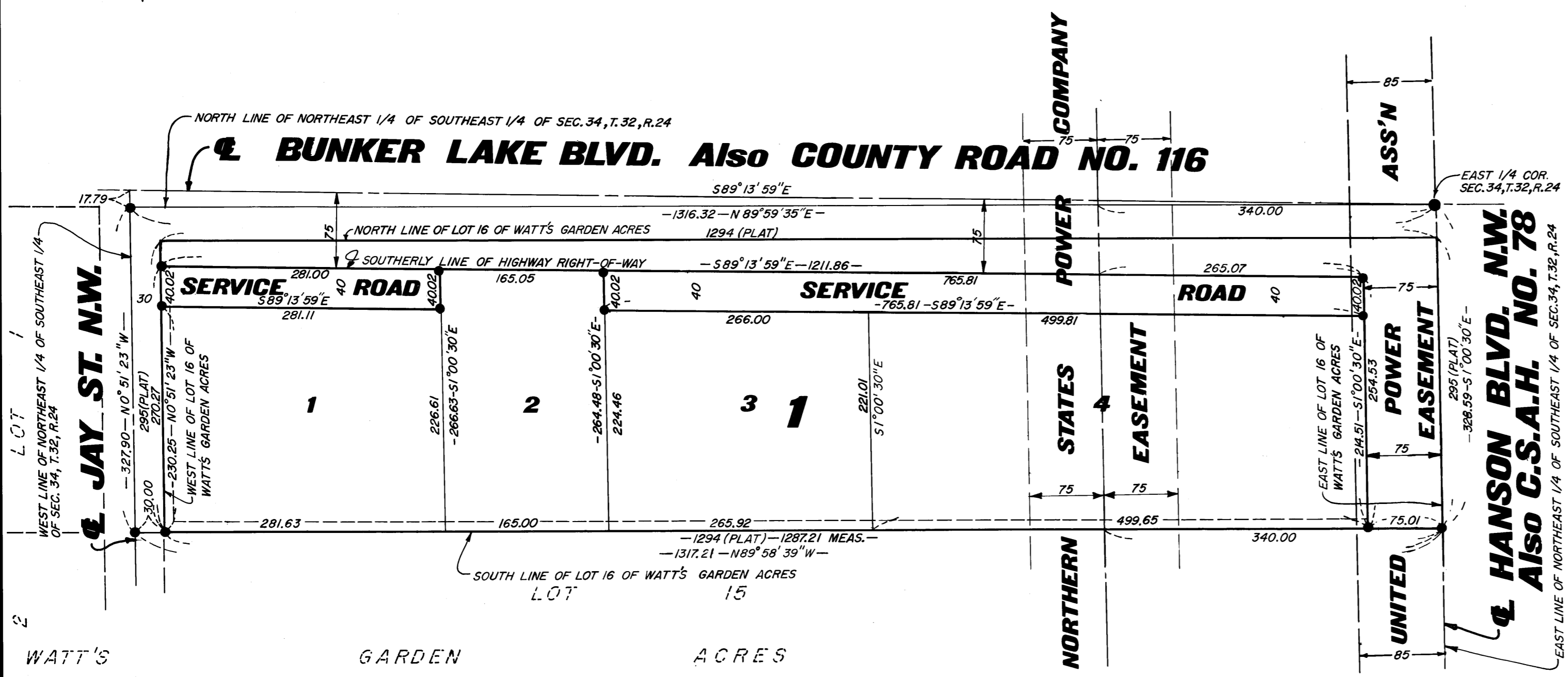
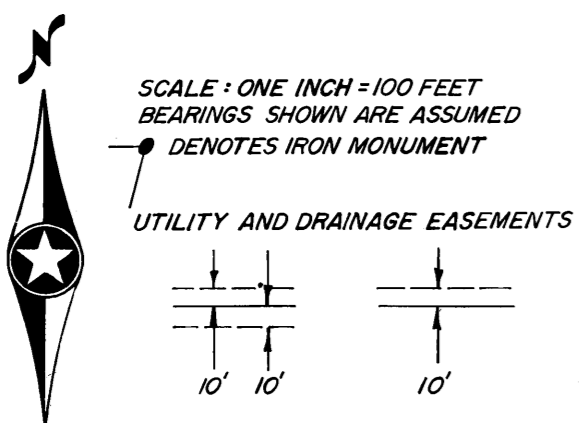

KNOW ALL MEN BY THESE PRESENTS: THAT ASSOCIATED DEVELOPMENTS CO., A MINNESOTA CORPORATION, FEE OWNER, AND BETTY A. ERICKSON, SINGLE, CONTRACT PURCHASER, AND LESLIE W. ERICKSON AND MURIEL ERICKSON, HIS WIFE, LIEN HOLDERS, AND LOUIS W. PANKONIN AND LOIS L. PANKONIN, HIS WIFE, CONTRACT PURCHASERS OF THE FOLLOWING DESCRIBED PROPERTY SITUATED IN THE STATE OF MINNESOTA AND THE COUNTY OF ANOKA TO-WIT:

LOT 16, WATT'S GARDEN ACRES, ACCORDING TO THE PLAT THEREOF ON FILE AND OF RECORD IN THE OFFICE OF THE REGISTRAR OF TITLES OF ANOKA COUNTY, MINNESOTA. SUBJECT TO EASEMENT TO RURAL COOPERATIVE POWER ASSOCIATION (NOW UNITED POWER ASSOCIATION) DATED APRIL 25, 1967 AND FILED AS DOCUMENT NO. 57771. ALSO SUBJECT TO EASEMENT TO NORTHERN STATES POWER COMPANY DATED SEPTEMBER 24, 1968 AND FILED AS DOCUMENT NO. 62294.

HAVE CAUSED THE SAME TO BE SURVEYED AND PLATTED AS PANKONIN ADDITION AND DO HEREBY DONATE AND DEDICATE TO THE PUBLIC FOR PUBLIC USE FOREVER THE BOULEVARDS, AND ROADS AS SHOWN ON THE PLAT, ALSO DEDICATING THE EASEMENTS FOR UTILITY AND DRAINAGE PURPOSES AS SHOWN ON THE PLAT. IN WITNESS WHEREOF SAID BETTY A. ERICKSON HAS HEREUNTO SET HER HAND AND SEAL ON THIS 17TH DAY OF July A.D. 1976. IN WITNESS WHEREOF SAID LESLIE W. ERICKSON AND MURIEL ERICKSON, HIS WIFE, HAVE HEREUNTO SET THEIR HANDS AND SEALS ON THIS 19TH DAY OF July A.D. 1976. IN WITNESS WHEREOF SAID LOUIS W. PANKONIN AND LOIS L. PANKONIN, HIS WIFE, HAVE HEREUNTO SET THEIR HANDS AND SEALS ON THIS 17TH DAY OF July A.D. 1976. IN WITNESS WHEREOF SAID ASSOCIATED DEVELOPMENTS CO. HAS CAUSED THESE PRESENTS TO BE SIGNED BY ITS PROPER OFFICERS AND ITS CORPORATE SEAL TO BE HEREUNTO AFFIXED ON THIS 20TH DAY OF July A.D. 1976.

SIGNED:

Betty A. Erickson
BETTY A. ERICKSON

Louis W. Pankonin
LOUIS W. PANKONIN

Lois L. Pankonin
LOIS L. PANKONIN

ASSOCIATED DEVELOPMENTS CO.

BY: Lea Christensen PRESIDENT

BY: Alice Scully ITS SECRETARY

Leslie W. Erickson
LESLIE W. ERICKSON

Muriel Erickson
MURIEL ERICKSON

STATE OF MINNESOTA) ss
COUNTY OF ANOKA) ss

THE FOREGOING INSTRUMENT WAS ACKNOWLEDGED BEFORE ME THIS 17TH DAY OF July A.D. 1976 BY BETTY A. ERICKSON, SINGLE.

DORETTA M. HOIUM
NOTARY PUBLIC - MINNESOTA
ANOKA COUNTY
My Commission Expires Sep. 5, 1976

STATE OF MINNESOTA) ss
COUNTY OF ANOKA) ss

THE FOREGOING INSTRUMENT WAS ACKNOWLEDGED BEFORE ME THIS 19TH DAY OF July A.D. 1976 BY LESLIE W. ERICKSON AND MURIEL ERICKSON, HIS WIFE.

LARRY D. HOIUM
NOTARY PUBLIC - MINNESOTA
ANOKA COUNTY
My Commission Expires Sep. 25, 1981

STATE OF MINNESOTA) ss
COUNTY OF ANOKA) ss

THE FOREGOING INSTRUMENT WAS ACKNOWLEDGED BEFORE ME THIS 17TH DAY OF July A.D. 1976 BY LOUIS W. PANKONIN AND LOIS L. PANKONIN, HUSBAND AND WIFE.

DORETTA M. HOIUM
NOTARY PUBLIC - MINNESOTA
ANOKA COUNTY
My Commission Expires Oct. 5, 1976

STATE OF MINNESOTA) ss
COUNTY OF ANOKA) ss

THE FOREGOING INSTRUMENT WAS ACKNOWLEDGED BEFORE ME THIS 20TH DAY OF July A.D. 1976 BY C.B. CHRISTENSEN AND ALICE SCULLY, PRESIDENT AND SECRETARY, RESPECTIVELY, OF ASSOCIATED DEVELOPMENTS CO., A MINNESOTA CORPORATION, ON BEHALF OF THE CORPORATION.

LARRY D. HOIUM
NOTARY PUBLIC - MINNESOTA
ANOKA COUNTY
My Commission Expires Sep. 25, 1981

I HEREBY CERTIFY THAT I HAVE SURVEYED AND PLATTED THE LAND DESCRIBED IN THE DEDICATION ON THE PLAT AS PANKONIN ADDITION; THAT THE PLAT IS A CORRECT REPRESENTATION OF SAID SURVEY; THAT ALL DISTANCES ARE CORRECTLY SHOWN ON SAID PLAT IN FEET AND DECIMALS OF A FOOT; THAT THE MONUMENTS HAVE BEEN CORRECTLY PLACED IN THE GROUND AS SHOWN; THAT THE OUTSIDE BOUNDARIES ARE CORRECTLY DESIGNATED ON SAID PLAT; AND THAT THERE ARE NO WET LANDS OR PUBLIC HIGHWAYS TO BE DESIGNATED ON SAID PLAT OTHER THAN ARE SHOWN THEREON.

M. C. Hoium
REGISTERED LAND SURVEYOR - MINN. REG. NO. 4427

STATE OF MINNESOTA) ss
COUNTY OF ANOKA) ss

A.D. 1976. THE SURVEYOR'S CERTIFICATE WAS SUBSCRIBED AND SWORN TO BEFORE ME THIS 17TH DAY OF July

LARRY D. HOIUM
NOTARY PUBLIC - MINNESOTA
ANOKA COUNTY
My Commission Expires Sep. 25, 1981

CHECKED AND APPROVED THIS 12TH DAY OF August A.D. 1976.

Richard W. Anderson
COUNTY SURVEYOR, ANOKA COUNTY, MINNESOTA

THIS PLAT WAS APPROVED AND ACCEPTED BY THE CITY COUNCIL OF THE CITY OF ANDOVER, ANOKA COUNTY, MINNESOTA AT A REGULAR MEETING HELD THIS 20TH DAY OF July A.D. 1976.

BY: Richard J. Schneider MAYOR

ATTEST: Patricia J. J. J. CLERK

30769

Office of REGISTRAR OF TITLES
STATE OF MINNESOTA
COUNTY OF ANOKA

I hereby certify that the within instrument was filed in this office on the 12 day of August 1976 at 10:30 clock A.M.

Ed. J. C. Embelke
Deputy Registrar of Titles

By: Ellen Boettcher
DEPUTY REGISTRAR OF TITLES

"NO DELINQUENT TAXES AND TRANSFER ENTERED"

August 12 1976

Charles R. L. L.
Auditor, Anoka County

By: J. Olson
Deputy

N.C. HOIUM & ASSOCIATES, INC.
LAND SURVEYORS