

PARKSIDE NORTH 6TH ADDITION

CITY OF BLAINE
COUNTY OF ANOKA
SEC. 12, TWP. 31, RGE. 23
Book 22 Jan Page 39

KNOW ALL PERSONS BY THESE PRESENTS: That Parkside North, LLC, a Minnesota limited liability company, owner of the following described property:

Outlot B and Outlot C, PARKSIDE NORTH 2ND ADDITION, according to the recorded plat thereof, Anoka County, Minnesota.

Has caused the same to be surveyed and platted as PARKSIDE NORTH 6TH ADDITION and does hereby dedicate to the public for public use the public way and the drainage and utility easements as created by this plat.

In witness whereof said Parkside North, LLC, a Minnesota limited liability company, has caused these presents to be signed by its proper officer this 11th day of JULY, 2016.

PARKSIDE NORTH, LLC

Kent A. Roessler
Kent A. Roessler, Chief Manager

STATE OF Minnesota
COUNTY OF Anoka

This instrument was acknowledged before me on July 11, 2016 by Kent A. Roessler, Chief Manager of Parkside North, LLC, a Minnesota limited liability company.

Pamela A. Brodeck
PAMELA A. BRODECK
Notary Public, HENNEPIN COUNTY, MN
My commission expires JAN. 31, 2020

I, Thomas R. Balluff do hereby certify that this plat was prepared by me or under my direct supervision; that I am a duly Licensed Land Surveyor in the State of Minnesota; that this plat is a correct representation of the boundary survey; that all mathematical data and labels are correctly designated on this plat; that all monuments depicted on this plat have been, or will be correctly set within one year; that all water boundaries and wet lands, as defined in Minnesota Statutes, Section 505.01, Subd. 3, as of the date of this certificate are shown and labeled on this plat; and all public ways are shown and labeled on this plat.

Dated this 6th day of JULY, 2016.

Thomas R. Balluff
Thomas R. Balluff, Licensed Land Surveyor
Minnesota License No. 40361

STATE OF Minnesota
COUNTY OF Anoka

This instrument was acknowledged before me on July 6th, 2016 by Thomas R. Balluff.

Cynthia J. Morical
Cynthia J. Morical
Notary Public, HENNEPIN COUNTY, MN
My commission expires Jan. 31, 2020

CITY COUNCIL, CITY OF BLAINE, MINNESOTA

This plat of PARKSIDE NORTH 6TH ADDITION was approved and accepted by the City Council of the City of Blaine, Minnesota at a regular meeting thereof held this 5th day of May, 2016, and said plat is in compliance with the provisions of Minnesota Statutes, Section 505.03, Subd. 4.

CITY COUNCIL, CITY OF BLAINE, MINNESOTA

By: *Jan Dy* Mayor By: *Chelle Johnson* Clerk

COUNTY SURVEYOR

I hereby certify that in accordance with Minnesota Statutes, Section 505.021, Subd. 11, this plat has been reviewed and approved this 3rd day of August, 2016.

Larry D. Holm
Larry D. Holm, Anoka County Surveyor

COUNTY AUDITOR/TREASURER

Pursuant to Minnesota Statutes, Section 505.021, Subd. 9, taxes payable in the year 2016 on the land hereinbefore described have been paid. Also, pursuant to Minnesota Statutes, Section 272.12, there are no delinquent taxes and transfer entered this 3rd day of August, 2016.

Jonell M. Sawyer
Jonell M. Sawyer
Property Tax Administrator
By: *Hatterson* Deputy

COUNTY RECORDER/REGISTRAR OF TITLES

County of Anoka, State of Minnesota

I hereby certify that this plat of PARKSIDE NORTH 6TH ADDITION was filed in the office of the County Recorder/Registrar of Titles for public record on this 3rd day of August, 2016, at 16:00 o'clock P.M. and was duly recorded in Book 22 Jan Page 39, as Document Number 340857.001.

Jonell M. Sawyer
Jonell M. Sawyer
County Recorder/Registrar of Titles
By: *Hatterson* Deputy

\$ 56.00

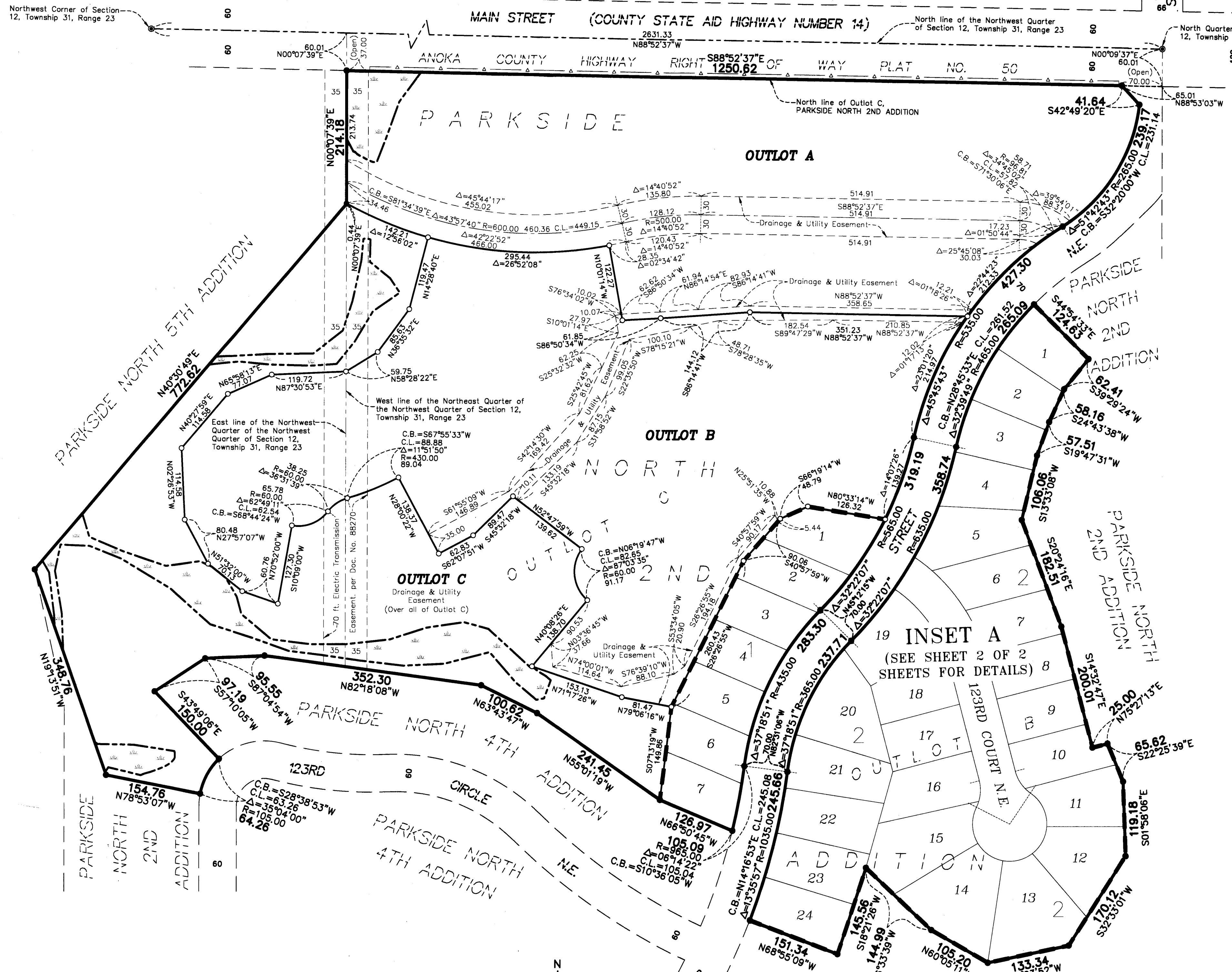

- Denotes Wetlands that were delineated by Kjolhaug Environmental Services in 2013.
- Denotes 1/2 inch by 14 inch iron monument set or to be set within one year of recording of this plat and marked with license number 40361
- Denotes Found Iron Monument
- Denotes Found Anoka County Cast Iron Monument
- Denotes Right of Access dedicated to Anoka County per the plat of PARKSIDE NORTH

For the purposes of this plat, the North line of Outlot C, PARKSIDE NORTH 2ND ADDITION is assumed to bear South 88 degrees 52 minutes 37 seconds East.

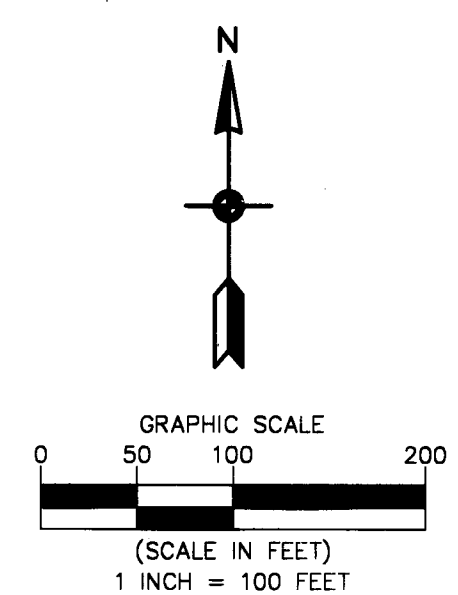

PARKSIDE NORTH 6TH ADDITION

INSET A

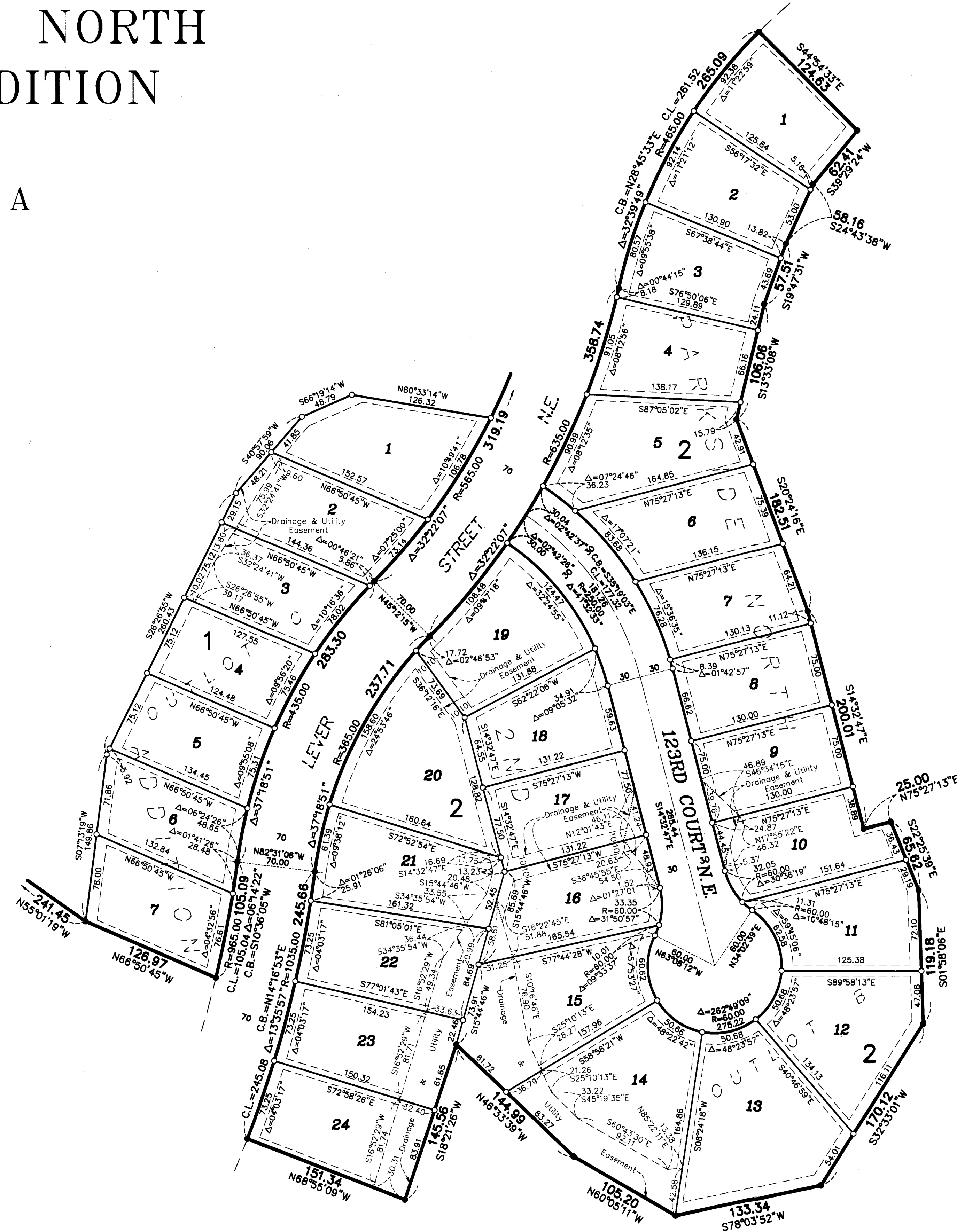

DRAINAGE AND UTILITY
EASEMENTS ARE SHOWN THUS:

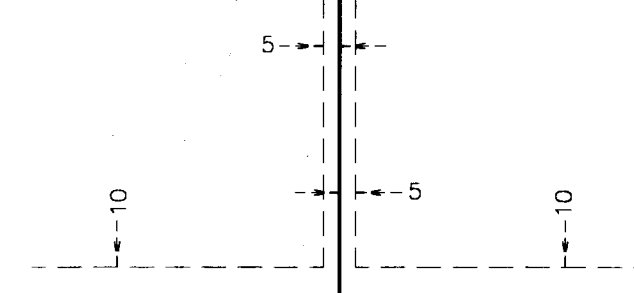

being 5 feet in width, and adjoining side lot lines, and 10 feet in width and adjoining right of way lines and rear lot lines unless otherwise shown on this plat.

- Denotes 1/2 inch by 14 inch iron monument set or to be set within one year of recording of this plat and marked with license number 40361
- Denotes Found Iron Monument

For the purposes of this plat, the North line of Outlot C, PARKSIDE NORTH 2ND ADDITION is assumed to bear South 88 degrees 52 minutes 37 seconds East.

