

1220148

PINE OAK CROSSING 2ND ADDITION

44

11:15
 23rd of May 1996
 Edward M. Treska
 County Recorder

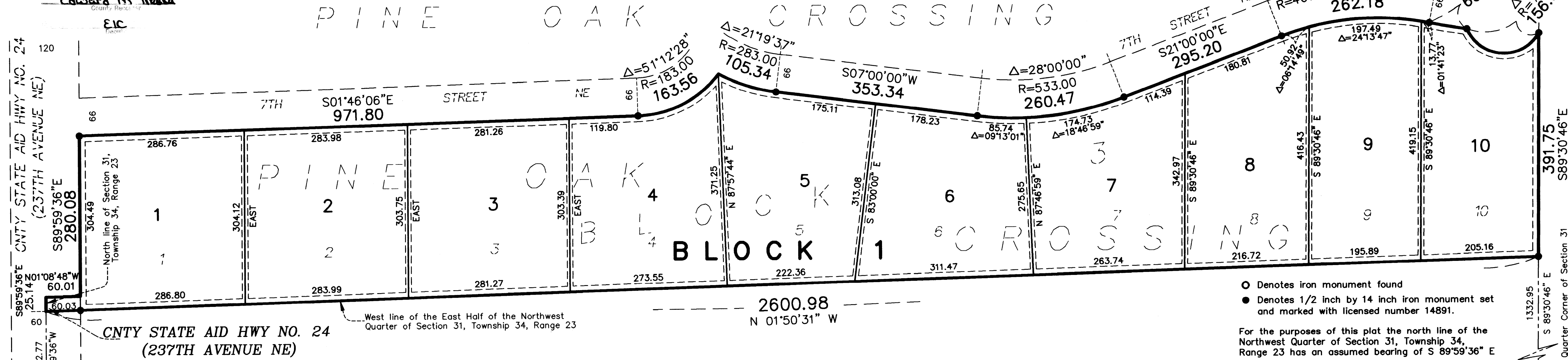

KNOW ALL MEN BY THESE PRESENTS: That Merit Development Co, LLP, a Minnesota Limited Liability Partnership owner and proprietor and Builders Development & Finance Inc., a Minnesota Corporation, Mortgagee of the following described property situated in the County of Anoka, State of Minnesota, to wit:

Lots 1, 2, 4, 5, 8, and 9, Block 3, PINE OAK CROSSING;

That Sterling Homes, Inc., a Minnesota Corporation, owner and proprietor and Merit Development Co., LLP, a Minnesota Limited Liability Partnership, mortgagee of the following described property situated in the County of Anoka, State of Minnesota, to wit:

Lots 7 and 10, Block 3, PINE OAK CROSSING;

That T & D Homes, Inc., a Minnesota Corporation, owner and proprietor and Builders Development & Finance, Inc., a Minnesota Corporation, mortgagee of the following described property situated in the County of Anoka, State of Minnesota, to wit:

Lots 6, Block 3, PINE OAK CROSSING;

That Metro Suburban Construction, Inc., a Minnesota Corporation, owner and proprietor and Security Bank of Waconia, a Minnesota Corporation, mortgagee of the following described property situated in the County of Anoka, State of Minnesota, to wit:

Lot 3, Block 3, PINE OAK CROSSING;

Have caused the same to be surveyed and platted as PINE OAK CROSSING 2ND ADDITION and do hereby donate and dedicate to the public for public use forever the avenue, easements for drainage and utility purposes only. In witness whereof said Merit Development Co., LLP, a Minnesota Limited Liability Partnership, has caused these presents to be signed by its proper officer this 17th day of May, 1996 and in witness whereof said Builders Development & Finance, Inc., a Minnesota Corporation has caused these presents to be signed by its proper officer this 17th day of May, 1996, and in witness whereof of said Sterling Homes, Inc., a Minnesota Corporation has caused these presents to be signed by its proper officer this 17th day of May, 1996, and in witness whereof of said T & D Homes, Inc., a Minnesota Corporation has caused these presents to be signed by its proper officer this 17th day of May, 1996, and in witness whereof of said Metro Suburban Construction, Inc., a Minnesota Corporation has caused these presents to be signed by its proper officer this 20th day of May, 1996, and in witness whereof of said Security Bank of Waconia, a Minnesota Corporation has caused these presents to be signed by its proper officer this 20th day of May, 1996.

MERIT DEVELOPMENT CO. LLP
 Todd D. Ganz, Partner

BUILDERS DEVELOPMENT & FINANCE, INC.
 Tim N. Goble, Vice President

STERLING HOMES, INC.
 Kevin R. Bialke, President

T & D HOMES, INC.
 Todd D. Ganz, President

METRO SUBURBAN CONSTRUCTION, INC.
 Thomas A. McFarlane, President

SECURITY BANK OF WACONIA
 Paul R. Johnson, Vice President

STATE OF MINNESOTA
 COUNTY OF Anoka

The foregoing instrument was acknowledged before me this 17th day of May, 1996, by Todd D. Ganz, partner of Merit Development Co. LLP, a Minnesota Limited Liability Partnership, on behalf of the partnership.

STATE OF MINNESOTA
 COUNTY OF Anoka

The foregoing instrument was acknowledged before me this 17th day of May, 1996, by Tim N. Goble, Vice President of Builders Development & Finance, Inc. a Minnesota Corporation, on behalf of the corporation.

JAN THOMAS SKURDAL
 NOTARY PUBLIC
 ANOKA COUNTY, MINNESOTA
 MY COMMISSION EXPIRES 01-31-2000

STATE OF MINNESOTA
 COUNTY OF Anoka

The foregoing instrument was acknowledged before me this 17th day of May, 1996, by Kevin R. Bialke, President of Sterling Homes, Inc., a Minnesota Corporation, on behalf of the corporation.

JAN THOMAS SKURDAL
 NOTARY PUBLIC
 ANOKA COUNTY, MINNESOTA
 MY COMMISSION EXPIRES 01-31-2000

STATE OF MINNESOTA
 COUNTY OF Anoka

The foregoing instrument was acknowledged before me this 17th day of May, 1996, by Todd D. Ganz, President of T & D Homes, a Minnesota Corporation, on behalf of the corporation.

JAN THOMAS SKURDAL
 NOTARY PUBLIC
 ANOKA COUNTY, MINNESOTA
 MY COMMISSION EXPIRES 01-31-2000

STATE OF MINNESOTA
 COUNTY OF Anoka

The foregoing instrument was acknowledged before me this 20th day of May, 1996, by Thomas A. McFarlane, President of Metro Suburban Construction, Inc., a Minnesota Corporation on behalf of the corporation.

JAN THOMAS SKURDAL
 NOTARY PUBLIC
 ANOKA COUNTY, MINNESOTA
 MY COMMISSION EXPIRES 01-31-2000

STATE OF MINNESOTA
 COUNTY OF Carver

The foregoing instrument was acknowledged before me this 21st day of May, 1996, by Paul R. Johnson, its Vice President of Security Bank of Waconia, a Minnesota Corporation, on behalf of the corporation.

CLAIRE R. WISCHNACK
 NOTARY PUBLIC-MINNESOTA
 CARVER COUNTY

I hereby certify that I have surveyed and platted the property described on this plat as PINE OAK CROSSING 2ND ADDITION, that this plat is a correct representation of the survey, that all distances are correctly shown on the plat in feet and hundredths of a foot; that all monuments have been correctly placed in the ground as shown or will be placed as required by the local governmental unit; that the outside boundary lines are correctly designated on the plat.

Robert B. Sikich, Land Surveyor
 Minnesota License Number 14891

STATE OF MINNESOTA
 COUNTY OF Anoka

The foregoing Surveyor's Certificate was acknowledged before me this 14th day of MAY, 1996 by Robert B. Sikich, Land Surveyor, Minnesota License No. 14891.

HOWARD W. ROGERS
 NOTARY PUBLIC - MINNESOTA
 SHERBURNE COUNTY
 MY COMM. EXP. 01/31/2000

EAST BETHEL, MINNESOTA

This plat of PINE OAK CROSSING 2ND ADDITION was approved and accepted by the City Council of the City of East Bethel, Minnesota, at a regular meeting thereof held this 15th day of May, A.D. 1996, if applicable, the written comments and recommendations of the Commissioner of Transportation and the County Highway Engineer have been received by the City or the prescribed 30 day period has elapsed without receipt of such comments and recommendation, as provided by Minnesota Statutes Section 505.03, Section 2.

By: Jerry Flame Mayor
 By: Sharon Anderson Clerk

Checked and approved this 23rd day of May, 1996
 By: Marjorie D. Olson
 Anoka County Surveyor

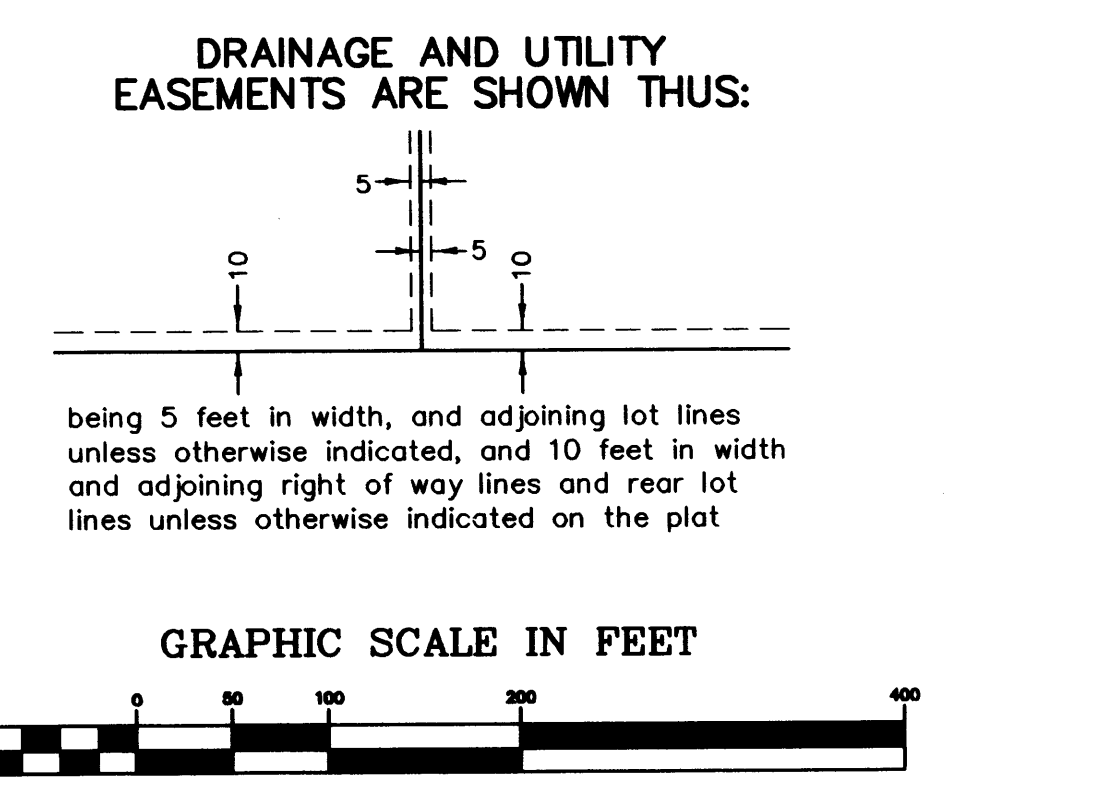

JAN THOMAS SKURDAL
 NOTARY PUBLIC
 MINNESOTA
 MY COMMISSION EXPIRES 01-31-2000

JAN THOMAS SKURDAL
 NOTARY PUBLIC
 ANOKA COUNTY, MINNESOTA
 My Commission Expires 01-31-2000

CLAIRE R. WISCHNACK
 NOTARY PUBLIC-MINNESOTA
 CARVER COUNTY

HEREBY CERTIFY THAT THE CURRENT AND DELINQUENT TAXES ON THE LANDS DESCRIBED WITHIN ARE PAID AND THE TRANSFER IS ENTERED
 May 23 1996
 EDWARD M. TRESKA
 PROPERTY TAX ADMINISTRATOR
 COUNTY PROPERTY TAX ADMINISTRATION

PIONEER engineering
 LAND SURVEYORS • CIVIL ENGINEERS
 LAND PLANNERS • LANDSCAPE ARCHITECTS

2422 Enterprise Drive
 Mendota Heights, MN 55120
 (612) 681-1914 FAX: 681-9488

625 Highway 10 N.E.
 Blaine, MN 55434
 (612) 783-1880 FAX: 783-1883

Receipt # 96033981 # 39552