

ANOKA COUNTY HIGHWAY RIGHT-OF-WAY PLAT NO. 4

County Highway Project No. SAP 02-607-12

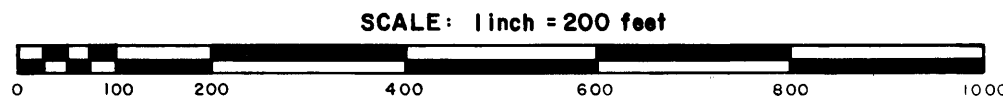

CONVENTIONAL SYMBOLS

- Section Line _____
- Quarter Line _____
- Quarter-quarter Line _____
- Property Line _____
- R/W Boundary Line _____
- Old Road R/W Line _____
- R/W Parcel No. _____
- Cast Iron Monument _____

PROCEDURAL STATEMENTS

1. The methods and equipment used in the control surveys for this plat and the checks made on monument location were accomplished with electronic distance measuring devices.
2. Certificates of location are on file in the Office of the County Surveyor for the section corner monuments shown on this plat.
3. For details of the control survey and land survey, contact the County Surveyor's Office for survey of R/W Plat No. 4, State Aid Project No. 02-607-12.
4. Bearings shown are assumed.

The Board of County Commissioners of Anoka County, Minnesota, pursuant to a Board Resolution dated May 11, 1976, is hereby designating the definite location of the Right of Way of County State Aid Highway No. 7, lying northerly of the South Line of Section 18, Township 32, and southerly of the North Line of Section 6, Township 32, Range 24, in the City of Andover.

That portion of said highway located in Section 6, Section 7, and Section 18, all in Township 32, Range 24, and in Section 1 and Section 12, both Township 32, Range 25, Anoka County, Minnesota as shown on this plat effected by the County of Anoka, Department of Highways, is hereby certified to be the official plat of that portion of said County State Aid Highway within said Sections pursuant to Minnesota Statutes 160.085.

Certified by: Paul K. Ruud, Registration No. 6549
Paul K. Ruud
County Highway Engineer

Date: June 24, 1976

I hereby certify that this is a true and correct representation of a survey of the boundaries as shown, and that said survey was made under my direct supervision, that all distances are correctly shown in feet and decimals of a foot, that the monuments for the guidance of future surveys will be correctly placed in the ground as shown after completion of construction, and that there are no wetlands or public highways to be designated on said plat other than as shown thereon.

Roland W. Anderson, Registration No. 5715
Roland W. Anderson
County Surveyor

Date: June 24, 1976

452122
OFFICE OF COUNTY RECORDER
STATE OF MINNESOTA, COUNTY OF ANOKA
I hereby certify that the within instrument was filed in this office for record on the SEP 3 1976 A.D., 19...
at 8 o'clock A.M., and was duly recorded in book PLAT BOOK 1 page 3
Fred J. Amshahl
County Recorder
By J. S. Hallenmaier
Deputy

RIGHT OF WAY IN SECTION 18							
PARCEL	OWNER	LOCATION	DEED RECORD document no. book of page	TORRENS CERTIFICATE NO.	ENTIRE TRACT acres	NEW HIGHWAY RIGHT OF WAY acres	BALANCE OF TRACT REMAINING acres
1	Norman D. Edwards	Pt. SE 1/4, SW 1/4	700,291		1.54	0.14	1.40
2	Helen M. Cogan	Pt. SW 1/4, SE 1/4	311,351		54.00	0.33	53.67
3	Lawrence B. Carlson	Pt. W 1/2, SE 1/4	433145		18.00	1.37	16.63
4	R.J.S. Builders, Inc.	Pt. NE 1/4, SW 1/4	1138,027		7.34	0.23	7.11
5	James W. Hunt	Pt. NW 1/4, SE 1/4 & Pt. NE 1/4, SW 1/4 & E 1/2, NW 1/4	218,018		129.00	5.67	123.33
6	Palmer F. Levenhagen & Merelyn E. Levenhagen	Pt. SW 1/4, NE 1/4	804,423	38135	1.00	0.10	0.90
7	James D. Stack	Pt. W 1/2, NE 1/4	155,481	40670	78.41	1.28	77.13

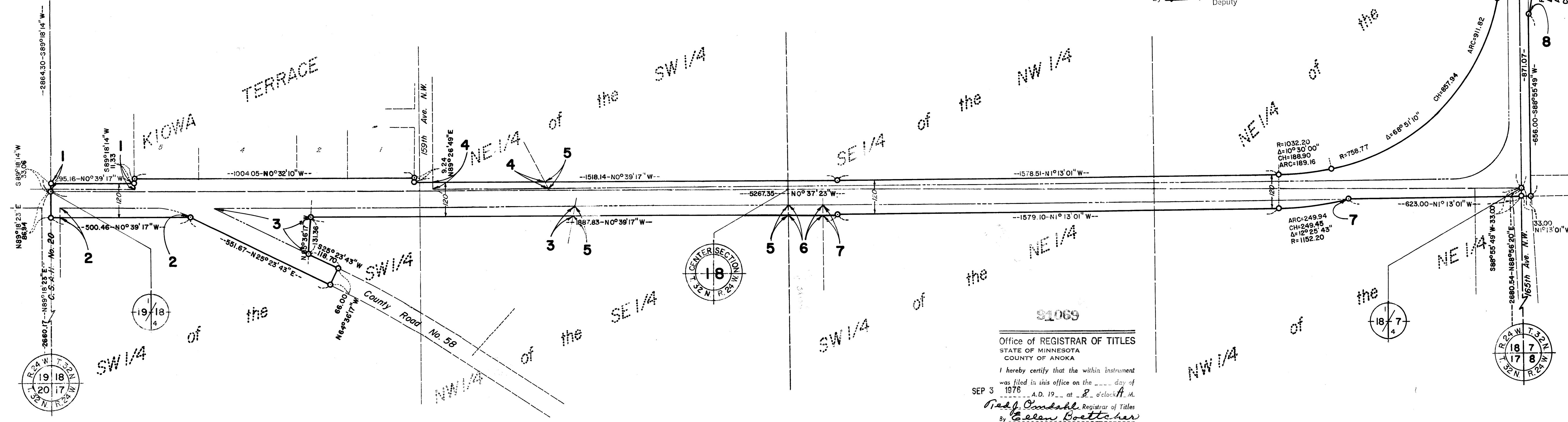
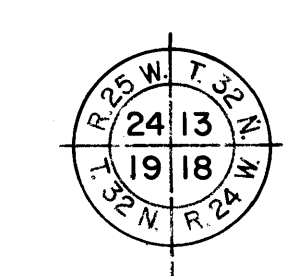

91069
Office of REGISTRAR OF TITLES
STATE OF MINNESOTA
COUNTY OF ANOKA
I hereby certify that the within instrument was filed in this office on the ___ day of SEP 3 1976 A.D. 19... at 8 o'clock A.M.
Fred J. Amshahl, Registrar of Titles
By Eileen Boettcher
DEPUTY REGISTRAR OF TITLES

ANOKA COUNTY HIGHWAY RIGHT-OF-WAY PLAT NO. 4

County Highway Project No. SAP 02-607-12

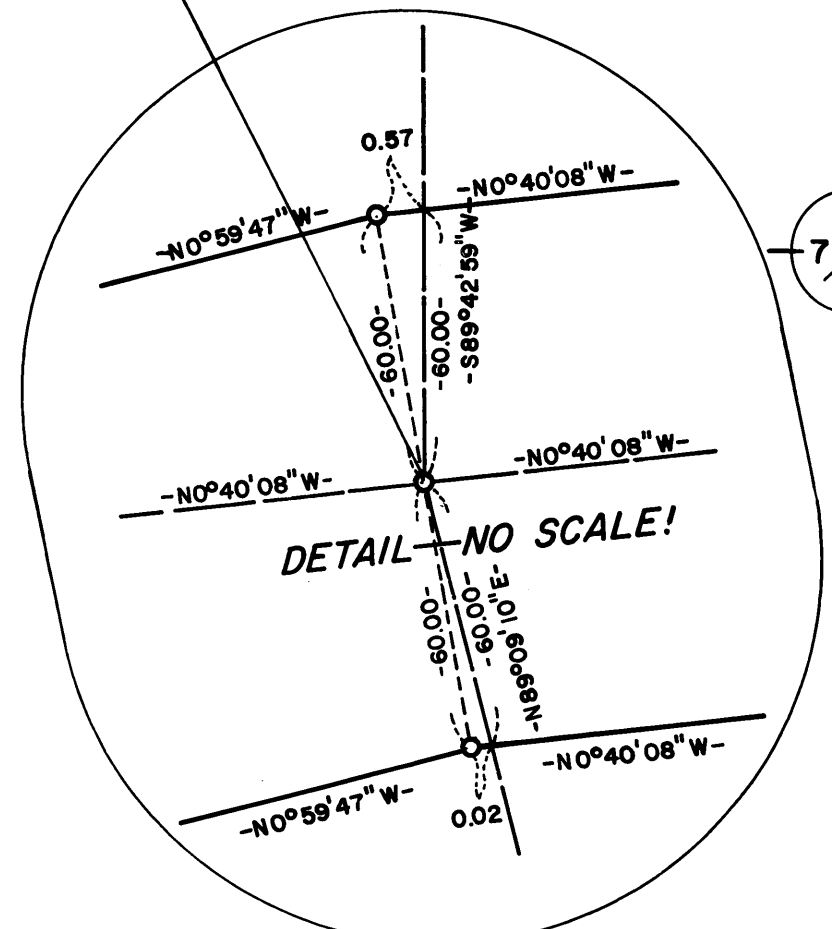
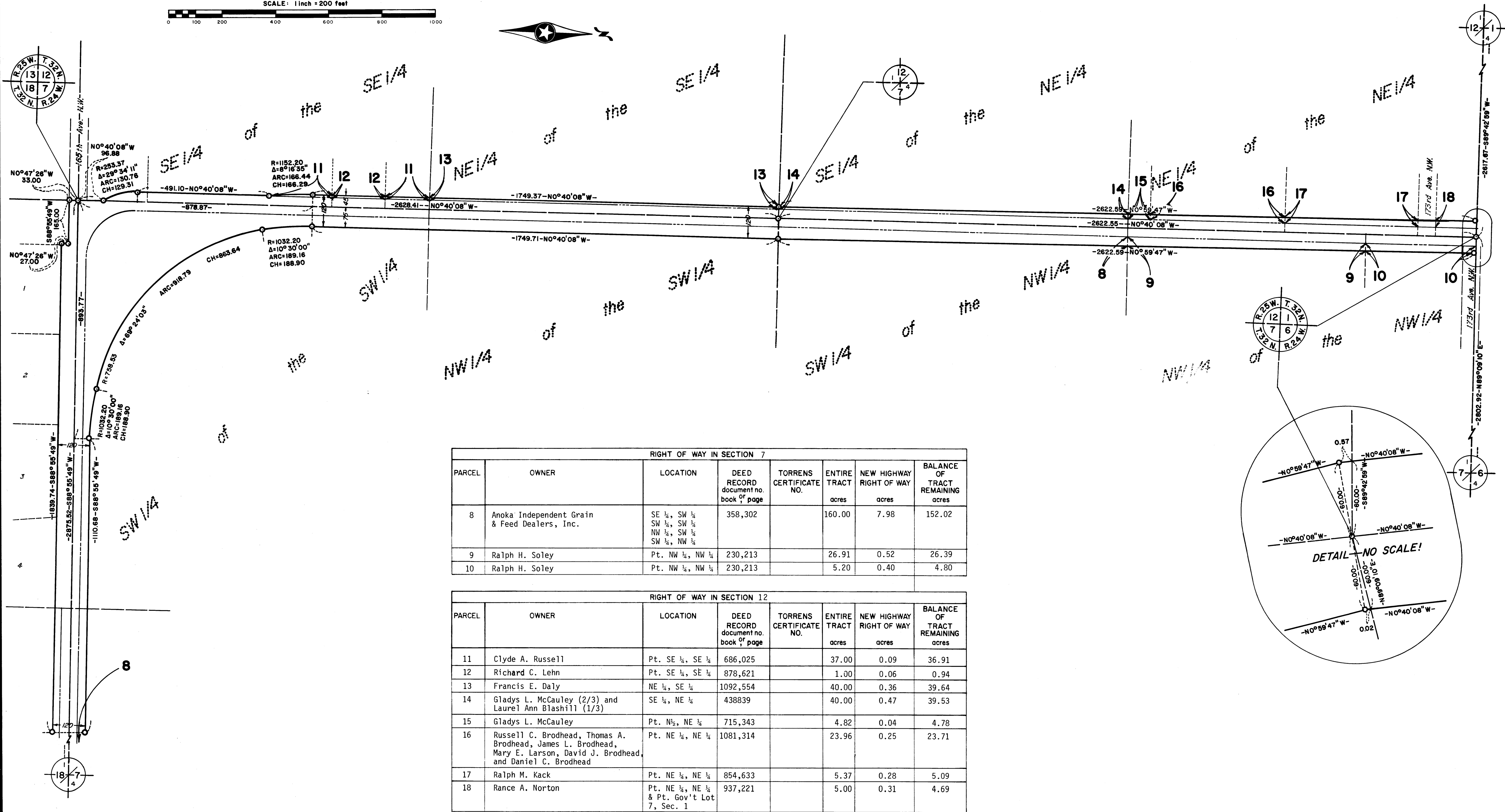
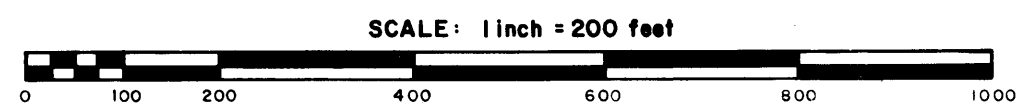

RIGHT OF WAY IN SECTION 7							
PARCEL	OWNER	LOCATION	DEED RECORD document no. book of page	TORRENS CERTIFICATE NO.	ENTIRE TRACT acres	NEW HIGHWAY RIGHT OF WAY acres	BALANCE OF TRACT REMAINING acres
8	Anoka Independent Grain & Feed Dealers, Inc.	SE 1/4, SW 1/4 SW 1/4, SW 1/4 NW 1/4, SW 1/4 SW 1/4, NW 1/4	358,302		160.00	7.98	152.02
9	Ralph H. Soley	Pt. NW 1/4, NW 1/4	230,213		26.91	0.52	26.39
10	Ralph H. Soley	Pt. NW 1/4, NW 1/4	230,213		5.20	0.40	4.80

RIGHT OF WAY IN SECTION 12							
PARCEL	OWNER	LOCATION	DEED RECORD document no. book of page	TORRENS CERTIFICATE NO.	ENTIRE TRACT acres	NEW HIGHWAY RIGHT OF WAY acres	BALANCE OF TRACT REMAINING acres
11	Clyde A. Russell	Pt. SE 1/4, SE 1/4	686,025		37.00	0.09	36.91
12	Richard C. Lehn	Pt. SE 1/4, SE 1/4	878,621		1.00	0.06	0.94
13	Francis E. Daly	NE 1/4, SE 1/4	1092,554		40.00	0.36	39.64
14	Gladys L. McCauley (2/3) and Laurel Ann Blashill (1/3)	SE 1/4, NE 1/4	438839		40.00	0.47	39.53
15	Gladys L. McCauley	Pt. NE 1/4, NE 1/4	715,343		4.82	0.04	4.78
16	Russell C. Brodhead, Thomas A. Brodhead, James L. Brodhead, Mary E. Larson, David J. Brodhead, and Daniel C. Brodhead	Pt. NE 1/4, NE 1/4	1081,314		23.96	0.25	23.71
17	Ralph M. Kack	Pt. NE 1/4, NE 1/4	854,633		5.37	0.28	5.09
18	Rance A. Norton	Pt. NE 1/4, NE 1/4 & Pt. Gov't Lot 7, Sec. 1	937,221		5.00	0.31	4.69

ANOKA COUNTY HIGHWAY RIGHT-OF-WAY PLAT NO. 4

County Highway Project No. SAP 02-607-12

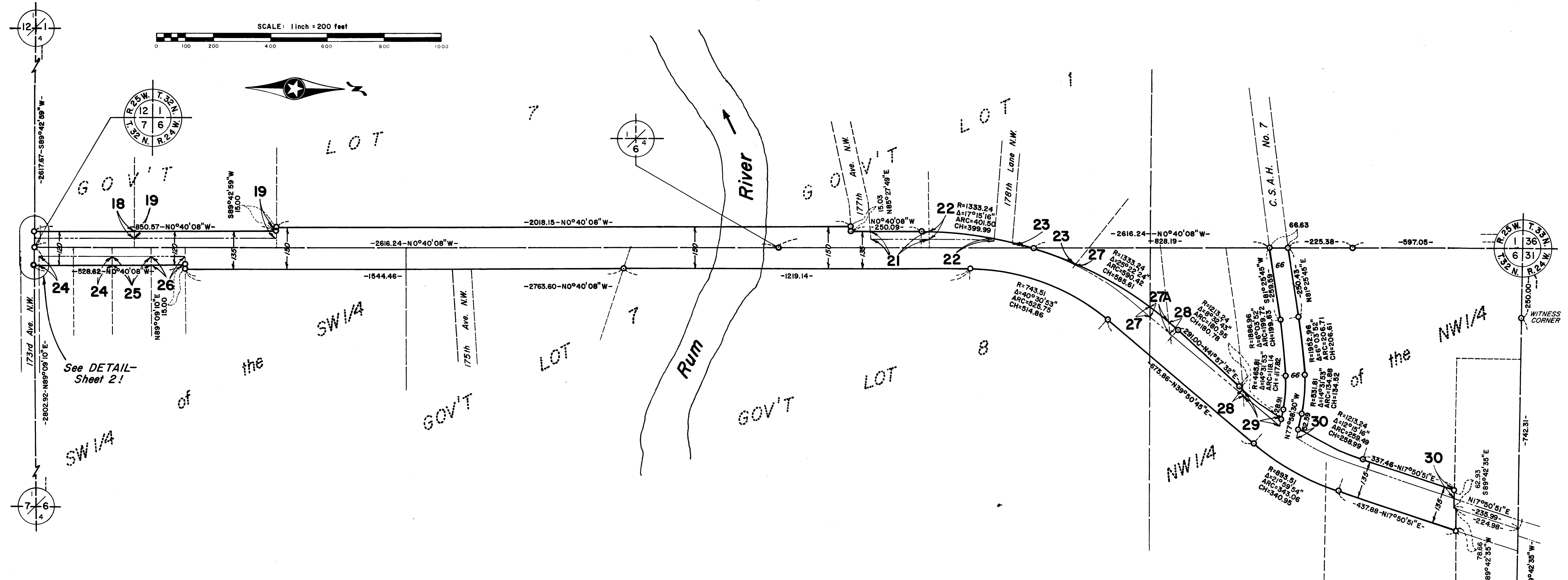

RIGHT OF WAY IN SECTION 1							
PARCEL	OWNER	LOCATION	DEED RECORD document no. book of page	TORRENS CERTIFICATE NO.	ENTIRE TRACT acres	NEW HIGHWAY RIGHT OF WAY acres	BALANCE OF TRACT REMAINING acres
18	SEE Section 12						
19	Russell C. Brodhead, Thomas A. Brodhead, James L. Brodhead, Mary E. Larson, David J. Brodhead, and Daniel C. Brodhead	Pt. Gov't Lot 7	1081,314		10.00	0.31	9.69
20	Ronald L. Danielson	Pt. Gov't Lot 1	1006,066		1.45		
21	Good Value Homes, Inc.	Pt. Gov't Lot 1	1001,616		1.15	0.13	1.02
22	John M. Johnson	Pt. Gov't Lot 1	975,295		1.25	0.10	1.15
23	Bryan T. Thompson	Pt. Gov't Lot 1 & pt. Gov't Lot 8, Sec. 6	1057,030		1.50	0.01	1.49

RIGHT OF WAY IN SECTION 6							
PARCEL	OWNER	LOCATION	DEED RECORD document no. book of page	TORRENS CERTIFICATE NO.	ENTIRE TRACT acres	NEW HIGHWAY RIGHT OF WAY acres	BALANCE OF TRACT REMAINING acres
24	Larry Ross Sturgeon	Pt. SW 1/4, SW 1/4	927,481		2.15	0.15	2.00
25	Bruce H. Perry	Pt. SW 1/4, SW 1/4	972,305		1.15	0.08	1.07
26	Virgil D. Westlund	Pt. SW 1/4, SW 1/4	1013,005		1.00	0.07	0.93
27	Louis James Esterby	Pt. Gov't Lot 8	1022,404		1.35	0.13	1.22
28	Aileen W. Sutherland	Pt. NW 1/4, NW 1/4	1077,499		2.50	0.16	2.34
29	Aileen W. Sutherland	Pt. NW 1/4, NW 1/4	397,015 814,527		2.00	0.07	1.93
30	Lawrence P. Keillor	Pt. NW 1/4, NW 1/4	214,432		16.00	0.39	15.61
27A	Louis James Esterby Aileen W. Sutherland	Pt. NW 1/4, NW 1/4	1022,404 1077,499			0.06	