

SKOGQUIST ACRES

BURNS TOWNSHIP, ANOKA COUNTY

1145864
OFFICE OF COUNTY RECORDER
STATE OF MINNESOTA, COUNTY OF ANOKA
I hereby certify that the within instrument was filed in this office for record on the Dec 2 day of AD, 1994 at 10:30 o'clock A.M., and was duly recorded in book 49 page 32
Edward M. Treska
County Recorder
KHJ

KNOW ALL MEN BY THESE PRESENTS: That Kenneth O. Skogquist, a single person, fee owner and proprietor of the following described property situated in the State of Minnesota, County of Anoka to wit:
That part of the Southwest Quarter of the Southeast Quarter of Section 19, Township 33, Range 25, Anoka County, Minnesota lying Easterly of County Road No. 65,
Exception No. 1
The East 400.00 feet of the West 800.00 feet of the South 545.00 feet of the said Southwest Quarter of the Southeast Quarter of said Section 19, Township 33, Range 25.
Exception No. 2
That part of the South 459.74 feet of the Southwest Quarter of the Southeast Quarter of Section 19, Township 33, Range 25, Anoka County, Minnesota lying East of the West 800.00 feet thereof, and lying West of the East 33.00 feet thereof.

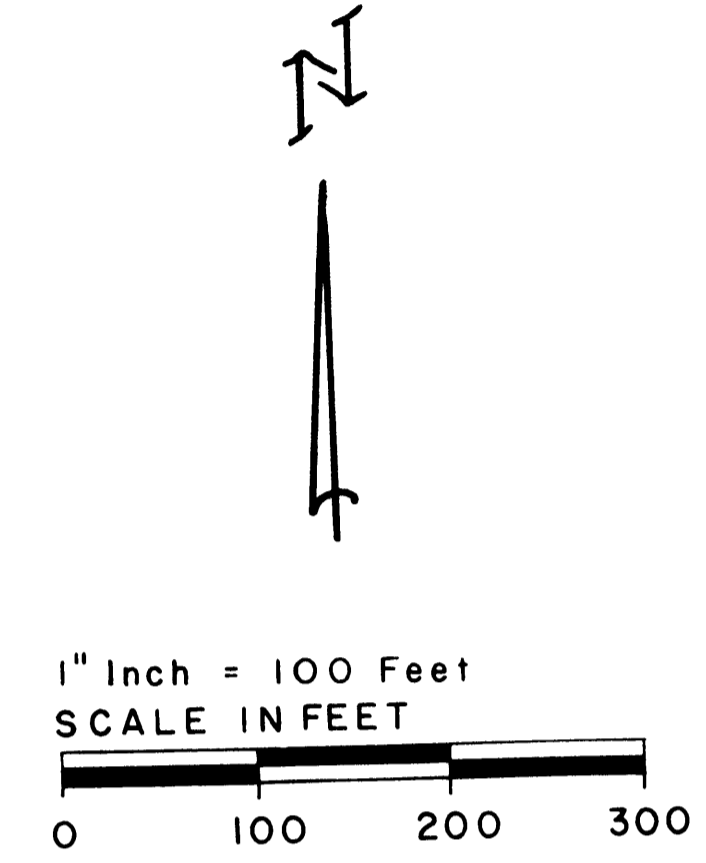
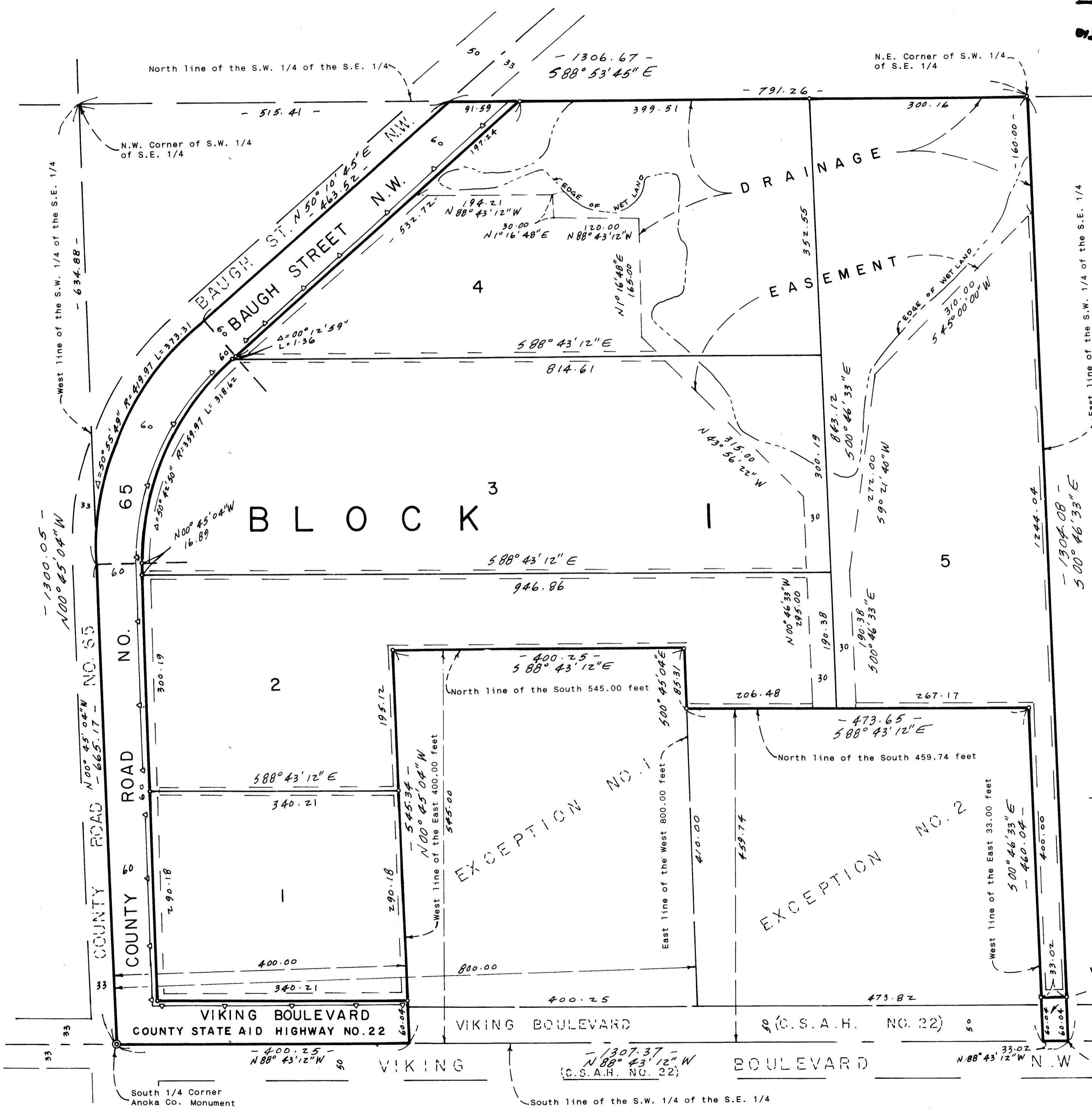

For the purposes of this plat, the south line of the Southwest Quarter of the Southeast Quarter is assumed to bear North 88 degrees 43 minutes 12 seconds West

Drainage and Utility Easements shown thus:

Being 10 feet in width and adjoining right-of-way lines and being 5 feet in width and adjoining lot lines unless otherwise indicated, as shown on this plat.

- o Denotes Iron Pipe Set with plastic plug stamped R.L.S. No. 12267.
- o— Denotes "RIGHT OF ACCESS" dedicated to Anoka County

Has caused the same to be surveyed and platted as SKOGQUIST ACRES, and do hereby donate and dedicate to the public for public use forever the Boulevard, Road and drainage and utility easements as shown on the plat. Also dedicating to the County of Anoka the right of access onto County State Aid Highway No. 22 and County Road No. 65 from Lots 1, 2, 3, 4, and 5, Block 1, as shown on the plat.
In witness whereof said Kenneth O. Skogquist, a single person has caused these presents to be signed this 12th day of September, 1994.
Kenneth O. Skogquist
Kenneth O. Skogquist

STATE OF MINNESOTA
COUNTY OF HENNEPIN
The foregoing instrument was acknowledged before me this 12th day of September, 1994 by Kenneth O. Skogquist, a single person.

Jeanette R. Kyro
Notary Public, Hennepin County, Minnesota
My Commission Expires 6/26/97

I hereby certify that I have surveyed and platted the property described on this plat as SKOGQUIST ACRES; that this plat is a correct representation of said survey; that all distances are correctly shown on the plat in feet and hundredths of a foot; that all monuments have been correctly placed in the ground as shown; that the outside boundary lines are correctly designated on the plat; and that there are no wet lands or public highways to be designated on the plat other than as shown.
James R. Kyro
James R. Kyro, Land Surveyor
Minnesota License No. 12267

STATE OF MINNESOTA
COUNTY OF HENNEPIN
The foregoing Surveyor's Certificate was acknowledged before me this 12th day of September, 1994, by James R. Kyro, Land Surveyor.

Jeanette R. Kyro
Notary Public, Hennepin County, Minnesota
My Commission Expires June 26, 1997

This plat of SKOGQUIST ACRES was approved by the Town Board of the Township of Burns, Minnesota, at a regular meeting thereof held this 12th day of September, 1994. If applicable, the written comments and recommendations of the Commissioner of Transportation and the County Highway Engineer have been received by the Township or the prescribed 30 day period has elapsed without receipt of such comments and recommendations, as provided by Minn. Statutes Section 505.03, Subd. 2.
By Henry Smith Chairman By Tommy Smolby Clerk

Recommended for approval this 14 day of September, 1994.
John Olson
Anoka County Highway Engineer

Approved as to form and execution this 11th day of October, 1994.
Anthony C. Blumso
Anoka County Attorney

This plat was approved and accepted by the Board of County Commissioners of the County of Anoka, State of Minnesota, at a regular meeting thereof held this 21st day of September, 1994.
Dan Edrunt Chairman
John Jay McQuinn County Administrator

Checked and approved this 15th day of Sept., 1994.
Mark D. Anderson
Anoka County Surveyor

I HEREBY CERTIFY THAT THE CURRENT AND DELINQUENT TAXES ON THE LANDS DESCRIBED WITHIN ARE PAID AND THE TRANSFER IS
ENTERED Dec 2 1994
EDWARD M. TRESKA
PROPERTY TAX ADMINISTRATOR
BY John S. Remington
DEPUTY PROPERTY TAX ADMINISTRATOR

Jim Kyro & Associates, Inc.
PROFESSIONAL LAND SURVEYORS
AND LAND DEVELOPMENT CONSULTANTS