

SPORTS HAVEN TOWNSHIP OF RAMSEY ANOKA COUNTY, MINNESOTA

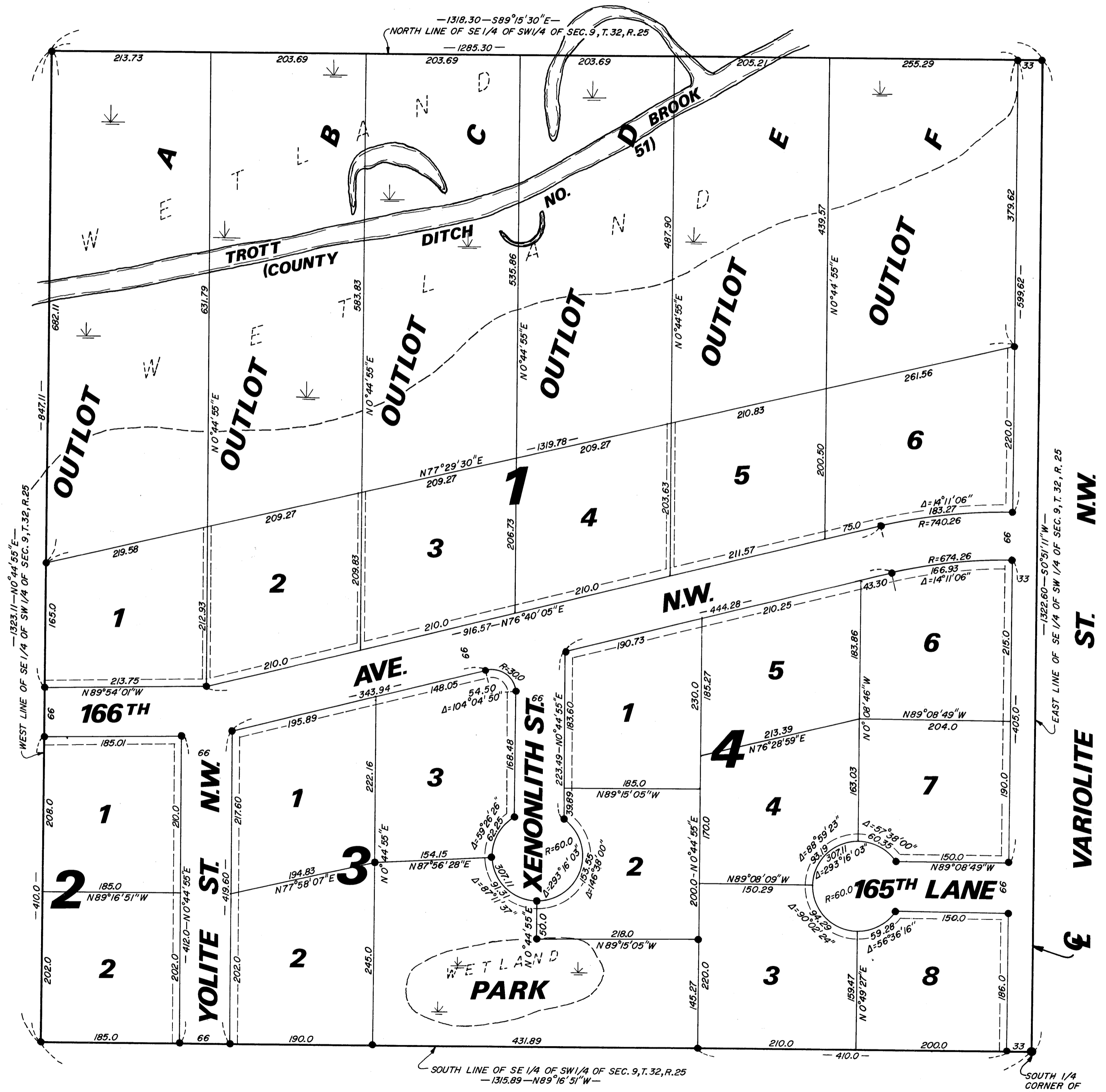
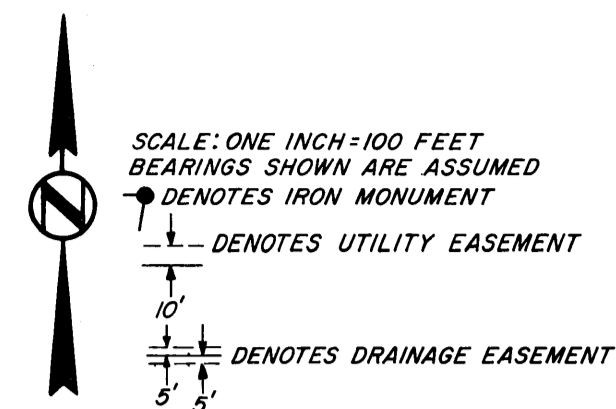

N.C. HOIUM & ASSOCIATES, INC.
Engineers Surveyors

KNOW ALL MEN BY THESE PRESENTS: THAT, CAR-SON LAND DEVELOPMENT CORPORATION, A MINNESOTA CORPORATION, OWNERS AND PROPRIETORS, AND WILLIAM W. MAKOWSKY AND MABEL MAKOWSKY, HIS WIFE, MORTGAGEES, OF THE FOLLOWING DESCRIBED PROPERTY SITUATED IN THE COUNTY OF ANOKA AND STATE OF MINNESOTA TO-WIT: THE SOUTHEAST 1/4 OF THE SOUTHWEST 1/4 OF SECTION 9, TOWNSHIP 32, RANGE 25.

HAVE CAUSED THE SAME TO BE SURVEYED AND PLATTED AS SPORTS HAVEN AND DO HEREBY DONATE AND DEDICATE TO THE PUBLIC FOR PUBLIC USE FOREVER THE AVENUE, STREETS, LANE AS SHOWN ON THE PLAT. ALSO DEDICATING THE EASEMENTS FOR UTILITY AND DRAINAGE PURPOSES AS SHOWN ON THE PLAT. IN WITNESS WHEREOF SAID WILLIAM W. MAKOWSKY AND MABEL MAKOWSKY, HIS WIFE, HAVE HEREUNTO SET THEIR HANDS AND SEALS ON THIS 13TH DAY OF JUNE A.D. 1972. ALSO CAR-SON LAND DEVELOPMENT CORPORATION, HAS CAUSED THESE PRESENTS TO BE SIGNED BY ITS PROPER OFFICER AND ITS CORPORATE SEAL TO BE HEREUNTO AFFIXED ON THIS 9TH DAY OF JUNE A.D. 1972.

IN THE PRESENCE OF:

Timothy J. Leh AND *Bruce L. Stromgren*
Timothy J. Leh AND *Bruce L. Stromgren*
Timothy J. Leh AND *N. C. Hoium*

SIGNED:

William W. Makowsky
WILLIAM W. MAKOWSKY
Mabel Makowsky
MABEL MAKOWSKY
CAR-SON LAND DEVELOPMENT CORPORATION
BY *Richard M. Carson* PRESIDENT
RICHARD M. CARSON

STATE OF MINNESOTA)
COUNTY OF ANOKA)

ON THIS 13TH DAY OF JUNE A.D. 1972, BEFORE ME, A NOTARY PUBLIC WITHIN AND FOR SAID COUNTY AND STATE, PERSONALLY APPEARED WILLIAM W. MAKOWSKY AND MABEL MAKOWSKY, HIS WIFE, TO ME PERSONALLY KNOWN TO BE THE PERSONS DESCRIBED IN AND WHO EXECUTED THE FOREGOING INSTRUMENT AND THEY AFFIRM AND ACKNOWLEDGE THE SAME AS THEIR OWN FREE ACT AND DEED.

MY COMMISSION EXPIRES 6-23-1977

Hail E. Schuette
NOTARY PUBLIC, ANOKA COUNTY, MINNESOTA

STATE OF MINNESOTA)
COUNTY OF ANOKA)

ON THIS 9TH DAY OF JUNE A.D. 1972, BEFORE ME, A NOTARY PUBLIC WITHIN AND FOR SAID COUNTY AND STATE, PERSONALLY APPEARED RICHARD M. CARSON, TO ME PERSONALLY KNOWN, WHO BEING BY ME DULY SWORN, DID SAY THAT HE IS THE PRESIDENT OF CAR-SON LAND DEVELOPMENT CORPORATION, THE CORPORATION NAMED IN THE FOREGOING INSTRUMENT; THAT THE SEAL AFFIXED TO SAID INSTRUMENT IS THE CORPORATE SEAL OF SAID CORPORATION; AND THAT SAID INSTRUMENT WAS SIGNED AND SEALED IN BEHALF OF SAID CORPORATION BY AUTHORITY OF ITS BOARD OF DIRECTORS, AND SAID RICHARD M. CARSON ACKNOWLEDGES SAID INSTRUMENT TO BE THE FREE ACT AND DEED OF SAID CORPORATION.

MY COMMISSION EXPIRES 6-23-1977

Hail E. Schuette
NOTARY PUBLIC, ANOKA COUNTY, MINNESOTA

STATE OF MINNESOTA)
COUNTY OF ANOKA)

I HEREBY CERTIFY THAT I HAVE SURVEYED AND PLATTED THE LAND DESCRIBED IN THE DEDICATION ON THIS PLAT AS SPORTS HAVEN; THAT THIS PLAT IS A CORRECT REPRESENTATION OF SAID SURVEY; THAT ALL DISTANCES ARE CORRECTLY SHOWN ON SAID PLAT; THAT ALL MONUMENTS HAVE BEEN CORRECTLY PLACED IN THE GROUND AS SHOWN; THAT THE OUTSIDE BOUNDARIES OF THE LAND ARE CORRECTLY DESIGNATED ON SAID PLAT; AND THAT THERE ARE NO WET LANDS OR PUBLIC HIGHWAYS TO BE DESIGNATED ON SAID PLAT OTHER THAN ARE SHOWN THEREON.

MY COMMISSION EXPIRES 6-23-1977

N. C. Hoium
REGISTERED LAND SURVEYOR - MINNESOTA REGISTRATION NO. 4427

STATE OF MINNESOTA)
COUNTY OF ANOKA)

STATE ON THIS 5TH DAY OF JUNE A.D. 1972, SURVEYOR'S CERTIFICATE SUBSCRIBED AND SWORN TO BEFORE ME, A NOTARY PUBLIC WITHIN AND FOR SAID COUNTY AND STATE.

MY COMMISSION EXPIRES 6-23-1977

Hail E. Schuette
NOTARY PUBLIC, ANOKA COUNTY, MINNESOTA

RECOMMENDED FOR APPROVAL THIS 20th DAY OF June A.D. 1972

C. J. Lundheim
ANOKA COUNTY HIGHWAY ENGINEER

THIS PLAT WAS APPROVED AS TO FORM AND EXECUTION ON THIS 12th DAY OF July A.D. 1972

Robert A. Jensen
COUNTY ATTORNEY, ANOKA COUNTY, MINNESOTA

ANNEXED PLAT OF SPORTS HAVEN WAS APPROVED BY THE TOWN BOARD OF THE TOWNSHIP OF RAMSEY AT A REGULAR MEETING THEREOF HELD THIS 19th DAY OF June A.D. 1972.

Herbert E. Murphy CHAIRMAN
James M. Peterson CLERK

ANNEXED PLAT OF SPORTS HAVEN WAS APPROVED BY THE PLANNING COMMISSION OF THE TOWNSHIP OF RAMSEY AT A REGULAR MEETING THEREOF HELD THIS 5th DAY OF June A.D. 1972.

Joy R. Reimann CHAIRMAN

CHECKED AND APPROVED THIS 20th DAY OF June A.D. 1972

Ronald W. Anderson
ANOKA COUNTY SURVEYOR

THIS PLAT WAS APPROVED AND ACCEPTED BY THE BOARD OF COUNTY COMMISSIONERS OF THE COUNTY OF ANOKA, STATE OF MINNESOTA, AT A REGULAR MEETING THEREOF HELD THIS 20th DAY OF June A.D. 1972

Robert A. Jensen CHAIRMAN
Charles R. Lefebvre COUNTY AUDITOR

"NO DELINQUENT TAXES AND TRANSFER ENTERED"

OFFICE OF REGISTER OF DEEDS
STATE OF MINNESOTA, COUNTY OF ANOKA

I hereby certify that the within instrument was filed in this office for record on the 12th day of July 1972 A.D. 1972 at 10 o'clock A.M. and was duly recorded in book 2 of Plat page 15.
BY *Anton K. Heintz* Deputy
Fred J. Oursell Register of Deeds
By *Margaret Oursell*

Charles R. Lefebvre COUNTY AUDITOR
by *Lulu E. Lage*, Deputy