

SULLIVAN LAKEVIEW

CITY OF COLUMBIA HEIGHTS
ANOKA COUNTY, MINNESOTA

CARTWRIGHT & OLSON
LAND SURVEYORS

OAK HILL
WASHINGTON ST. N.E.
ADD.

North line of Sec. 26, T-30, R-24 Also North line of Lot 1, Aud. Subd. No. 51

53RD AVE. N.E. 120.0

West line of NW 1/4 of Sec. 26, T-30, R-24 Also West line of Lot 1, Aud. Subd. No. 51

7TH ST. N.E.
RAND SECOND ADD.
60 WASHINGTON ST. N.E.

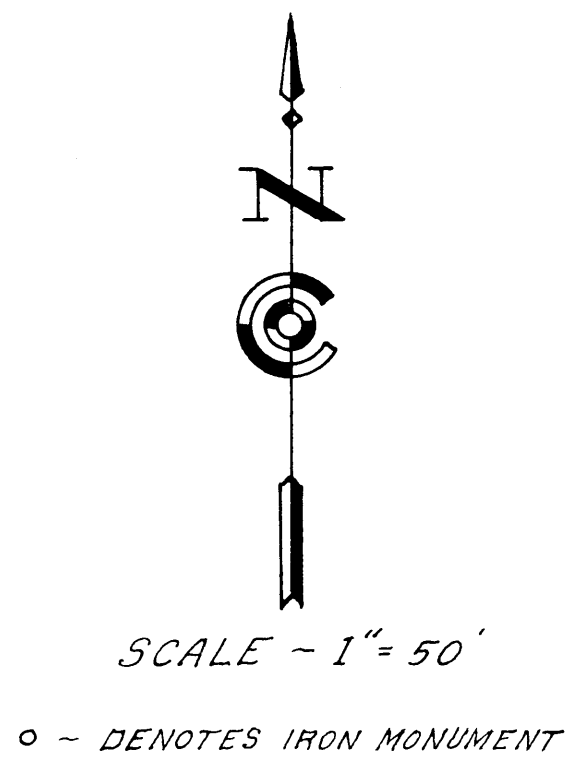
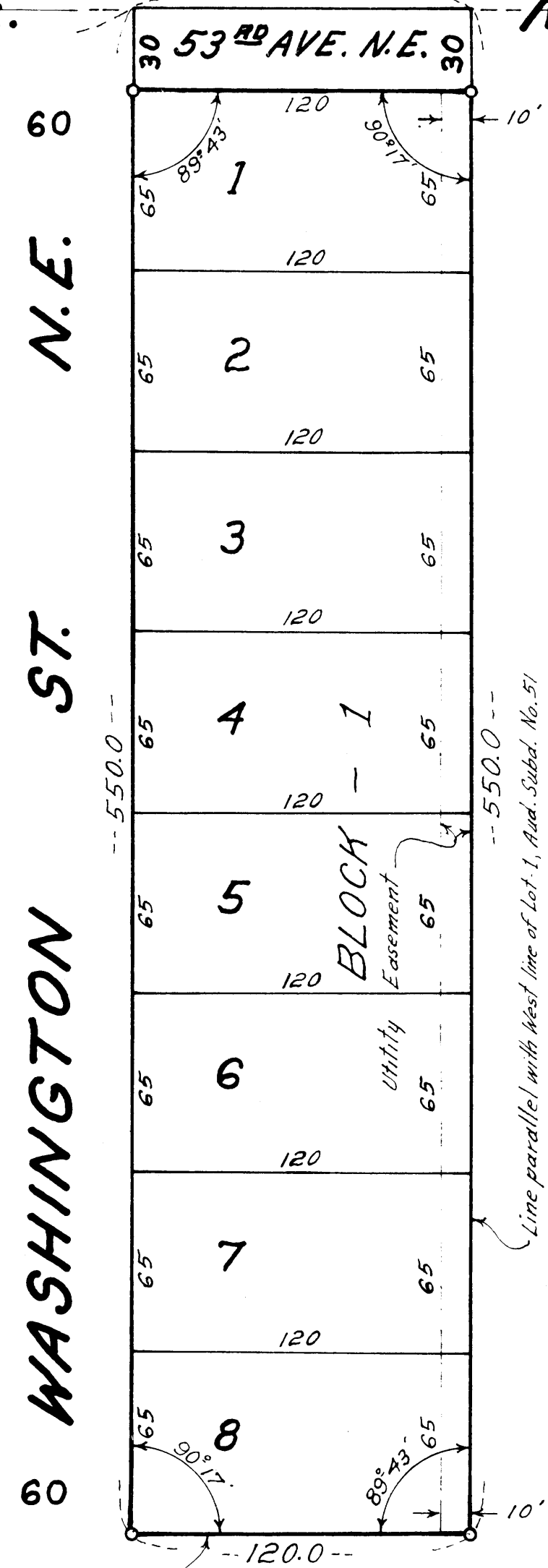

KNOW ALL MEN BY THESE PRESENTS: THAT WE, JOHN H. GLOVER HOUSES, INC., A MINNESOTA CORPORATION, OWNERS AND PROPRIETORS OF THE FOLLOWING DESCRIBED PROPERTY SITUATE IN THE STATE OF MINNESOTA AND COUNTY OF ANOKA TO-WIT: THAT PART OF LOT 1, AUDITOR'S SUBDIVISION No. 51, ACCORDING TO THE PLAT THEREOF ON FILE AND OF RECORD IN THE OFFICE OF THE REGISTER OF DEEDS, ANOKA COUNTY, MINNESOTA, DESCRIBED AS FOLLOWS: COMMENCING AT A POINT ON THE NORTH LINE OF SAID LOT 1, DISTANT 310 FEET EAST FROM THE NORTH-WEST CORNER OF SAID LOT 1; THENCE EAST ON THE NORTH LINE OF SAID LOT 1 A DISTANCE OF 120 FEET; THENCE SOUTH PARALLEL WITH THE WEST LINE OF SAID LOT 1 A DISTANCE OF 550 FEET; THENCE WEST PARALLEL WITH THE NORTH LINE OF SAID LOT 1 A DISTANCE OF 120 FEET; THENCE NORTH PARALLEL WITH THE WEST LINE OF SAID LOT 1 A DISTANCE OF 550 FEET TO THE POINT OF BEGINNING. HAVE CAUSED THE SAME TO BE SURVEYED AND PLATTED AS SULLIVAN LAKEVIEW, AND DO HEREBY DONATE AND DEDICATE TO THE PUBLIC FOR THE PUBLIC USE FOREVER THE AVENUE AS SHOWN ON THE ANNEXED PLAT, ALSO SUBJECT TO UTILITY EASEMENTS AS SHOWN ON THE ANNEXED PLAT. IN WITNESS WHEREOF SAID JOHN H. GLOVER HOUSES, INC., HAS CAUSED THESE PRESENTS TO BE SIGNED BY ITS PROPER OFFICERS AND ITS CORPORATE SEAL TO BE HEREUNTO AFFIXED THIS 22 DAY OF July 1963.

IN PRESENCE OF: Iren Dastaler AND Albert V. Rosenbower

SIGNED: John H. Glover ITS PRESIDENT
JOHN H. GLOVER HOUSES, INC.

STATE OF MINNESOTA
COUNTY OF HENNEPIN

ON THIS 22 DAY OF July A.D. 1963, BEFORE ME A NOTARY PUBLIC WITHIN AND FOR SAID COUNTY AND STATE PERSONALLY APPEARED JOHN H. GLOVER, TO ME PERSONALLY KNOWN, WHO BEING BY ME DULY SWORN DID SAY THAT HE IS THE PRESIDENT OF JOHN H. GLOVER HOUSES, INC., THE CORPORATION NAMED IN THE FOREGOING INSTRUMENT, THAT THE SEAL AFFIXED TO SAID INSTRUMENT IS THE CORPORATE SEAL OF SAID CORPORATION AND THAT SAID INSTRUMENT WAS SIGNED AND SEALED IN BEHALF OF SAID CORPORATION BY AUTHORITY OF ITS BOARD OF DIRECTORS AND SAID JOHN H. GLOVER ACKNOWLEDGES SAID INSTRUMENT TO BE THE FREE ACT AND DEED OF SAID CORPORATION.

Albert V. Rosenbower
NOTARY PUBLIC, HENNEPIN COUNTY, MINNESOTA
ALBERT V. ROSENBOOWER
Notary Public, Hennepin County, Minn.
My Commission Expires Dec. 9, 1968

I HEREBY CERTIFY THAT I HAVE SURVEYED AND PLATTED THE PROPERTY DESCRIBED ON THIS PLAT AS SULLIVAN LAKEVIEW, THAT THIS PLAT IS A CORRECT REPRESENTATION OF SAID SURVEY; THAT ALL DISTANCES ARE CORRECTLY SHOWN ON THE PLAT IN FEET AND DECIMALS OF A FOOT; THAT THE MONUMENTS FOR THE GUIDANCE OF FUTURE SURVEYS HAVE BEEN CORRECTLY PLACED IN THE GROUND AS SHOWN ON THE PLAT; THAT THE OUTSIDE BOUNDARY LINES ARE CORRECTLY DESIGNATED ON THE PLAT AND THAT THERE ARE NO WET LANDS OR PUBLIC HIGHWAYS TO BE DESIGNATED ON SAID PLAT OTHER THAN SHOWN THEREON.

Harvey A. Cartwright
REGISTERED LAND SURVEYOR - MINNESOTA REG. NO. 1983

STATE OF MINNESOTA
COUNTY OF HENNEPIN

ABOVE CERTIFICATE SUBSCRIBED AND SWORN TO BEFORE ME A NOTARY PUBLIC WITHIN AND FOR SAID COUNTY AND STATE THIS 19 DAY OF July 1963.

Clara Mae Dickey
NOTARY PUBLIC, HENNEPIN COUNTY, MINNESOTA
CLARA MAE DICKEY
Notary Public, Hennepin County, Minn.
My Commission Expires April 11, 1968

WE HEREBY CERTIFY THAT THE CITY COUNCIL OF THE CITY OF COLUMBIA HEIGHTS, ANOKA COUNTY, MINNESOTA, DULY ACCEPTED AND APPROVED THE ANNEXED PLAT OF SULLIVAN LAKEVIEW AT A REGULAR MEETING THEREOF HELD THIS 19 DAY OF July 1963.

I HEREBY CERTIFY THAT TAXES FOR THE YEAR 1962 ON THE LANDS DESCRIBED WITHIN ARE PAID

Robert J. Peterson
County Treasurer

CITY OF COLUMBIA HEIGHTS, ANOKA COUNTY, MINNESOTA
BY Warren A. Armstrong ITS MAYOR
BY R.C. Larsson ITS CITY CLERK

TAXES PAID
This 20th day of Aug 1963
Kenneth W. Campbell
Auditor, Anoka County, Minn.
Wayne Akers Deputy

THIS PLAT APPROVED AS TO FORM AND EXECUTION ON THIS 19th DAY OF August 1963.
Stewart J. Franklin
CITY ATTORNEY, COLUMBIA HEIGHTS, MINNESOTA

OFFICE OF REGISTRAR OF TITLES
STATE OF MINNESOTA
COUNTY OF ANOKA
I hereby certify that the within instrument was filed in this office on the 20 day of August 1963
August 20 1963
Henriette Skinner Registrar of Titles
By Edmund Boettcher DEPUTY REGISTRAR OF TITLES

CHECKED AND APPROVED THIS 20th DAY OF August 1963.
BY Blond W. Anderson
COUNTY SURVEYOR, ANOKA COUNTY, MINNESOTA