

TPC FIRST ADDITION

KNOW ALL MEN BY THESE PRESENTS: That Sienna Corporation, a Minnesota corporation, owner and proprietor, and Tournament Players Club of the Twin Cities, LLC, a Minnesota limited liability company, contract purchaser, of the following described property situated in the County of Anoka, State of Minnesota, to wit:

The Northwest Quarter and the Southwest Quarter of Section 16, Township 31, Range 23.

The Northwest Quarter of the Northeast Quarter and that part of the Northeast Quarter of the Northeast Quarter of Section 16, Township 31, Range 23, lying west of County Road No. 52 (formerly known as the Bethel and Rice Creek Road), Except that part thereof described as follows: Beginning at the Northwest corner of said Northeast Quarter of the Northeast Quarter: thence South 89 degrees 21 minutes 38 seconds East, assumed bearing, along the North line of said Northeast Quarter of the Northeast Quarter a distance of 860.78 feet to the center line of County Road No. 52 as now laid out and traveled; thence South 31 degrees 23 minutes 58 seconds East, along said center line, a distance of 300.00 feet; thence North 89 degrees 21 minutes 38 seconds West a distance of 250.00 feet; thence South 60 degrees 38 minutes 22 seconds West a distance of 260.00 feet; thence North 73 degrees 32 minutes 54 seconds West a distance of 566.29 feet to the West line of said Northeast Quarter of the Northeast Quarter; thence North 00 degrees 39 minutes 52 minutes East, along said West line, a distance of 230.00 feet to the point of beginning.

Outlot A, North Oaks West Second Addition

The South Half of the Northeast Quarter of Section 16, Township 31, Range 23; and all that part of the Southwest Quarter of the Northwest Quarter of Section 15, Township 31, Range 23, lying west of County Road No. 52 (formerly known as the Bethel and Rice Creek Road).

That part of the Northeast Quarter of the Southeast Quarter of Section 16, lying Northwesterly of the Bethel and Rice Creek Road, and lying Northeasterly of County Ditch No. Forty-one (41), being in Township 31, Range 23, Anoka County, Minnesota, according to the Government Survey thereof.

All that part of North Half of Southeast Quarter of Section 16, which lies Westerly of the Bethel and Rice Creek Road, EXCEPT that part of the Northeast Quarter of the Southeast Quarter of Section 16, lying Northwesterly of the Bethel and Rice Creek Road, and lying Northeasterly of County Ditch No. Forty-one (41), being in Township 31, Range 23, Anoka County, Minnesota, according to the Government Survey thereof.

Have caused the same to be surveyed and platted as TPC FIRST ADDITION and do hereby donate and dedicate to the public for public use forever the avenues, drive, road, courts, parkway and easements for drainage and utility purposes only. Also dedicating to the County of Anoka the right of access onto County State Aid Highway No. 12 and County Road No. 52, as designated on this plat.

In witness whereof said Sienna Corporation, a Minnesota corporation, has caused these presents to be signed by its proper officer this 4th day of June 1998 and in witness whereof said Tournament Players Club of the Twin Cities, LLC, a Minnesota limited liability company, has caused these presents to be signed by its proper officers this 3rd day of June 1998.

SIENNA CORPORATION

TOURNAMENT PLAYERS CLUB OF THE TWIN CITIES, LLC

B.G. Nimmer
B.G. Nimmer as President

Keith W. Tomlinson
KEITH W. TOMLINSON as TREASURER
Robert H. Enebak
Robert H. Enebak as Manager

STATE OF MINNESOTA
COUNTY OF Hennepin

The foregoing instrument was acknowledged before me this 4th day of June 1998 by B.G. Nimmer as president of Sienna Corporation, a Minnesota Corporation, on behalf of the corporation.

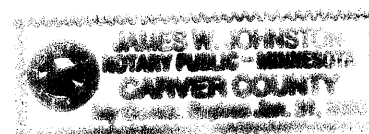

[Signature]
Notary Public, Carver County, Minnesota
My Commission Expires January 31, 2000

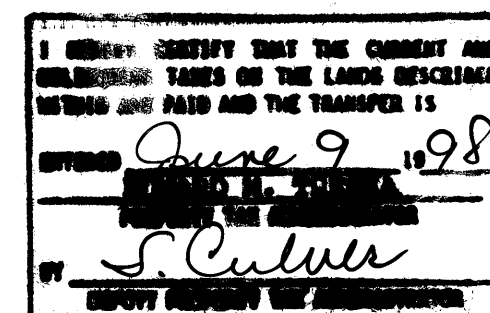

STATE OF MINNESOTA
COUNTY OF Anoka

The foregoing instrument was acknowledged before me this 3rd day of June 1998 by Keith W. Tomlinson and Robert H. Enebak, the Treasurer and Manager respectively, of Tournament Players Club of the Twin Cities, LLC, a Minnesota limited liability company, on behalf of the limited liability company.

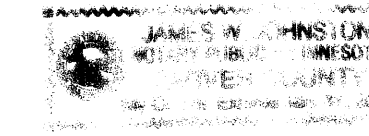

[Signature]
Notary Public, Carver County, Minnesota
My Commission Expires January 31, 2000

I hereby certify that I have surveyed and platted the property described on this plat as TPC FIRST ADDITION; that this plat is a correct representation of the survey; that all distances are correctly shown on the plat in feet and hundredth of a foot; that all monuments have been correctly placed in the ground as shown or will be placed as required by the local governmental unit; that the outside boundary lines are correctly designated on the plat; and that there are no wetlands, in accordance with section 505.02 Subdivision 1, or public highways to be designated other than as shown.

Terrence E. Rothenbacher
Terrence E. Rothenbacher, Land Surveyor
Minnesota License Number 20595

STATE OF MINNESOTA
COUNTY OF Anoka

The foregoing instrument was acknowledged before me this 2nd day of APRIL 1998, by Terrence E. Rothenbacher, Land Surveyor, Minnesota License No. 20595.

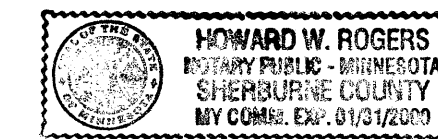

[Signature]
Notary Public, Sherburne County, Minnesota
My Commission Expires January 31, 2000

BLAINE, MINNESOTA

This plat of TPC FIRST ADDITION was approved and accepted by the City Council of the City of Blaine, Minnesota, at a regular meeting thereof held this 19th day of February 1998. If applicable, the written comments and recommendations of the Commissioner of Transportation and the County Highway Engineer have been received by the City or the prescribed 30 day period has elapsed without receipt of such comments and recommendation, as provided by Minnesota Statutes Section 505.03, Section 2.

By: Sam Ferguson Mayor By: Joyce Thurston Clerk

Checked and approved this 9th day of JUNE 1998.

By: [Signature]
Anoka County Surveyor

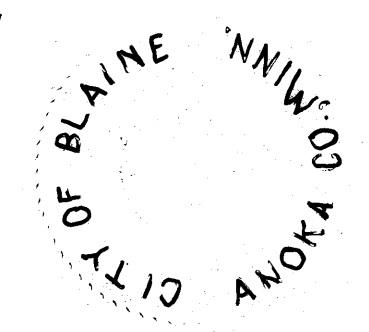

1347902
OFFICE OF COUNTY RECORDER
STATE OF MINNESOTA, COUNTY OF ANOKA
I hereby certify that the within instrument was filed in this office for record on the 9th day of June A.D., 1998 at 3 o'clock P.M., and was duly recorded in book 55 page 55

313719
Office of REGISTRAR OF TITLES
STATE OF MINNESOTA
COUNTY OF ANOKA
I hereby certify that the within instrument was filed in this office on JUN - 9 1998 at 3 o'clock P.M.
Edward M. Treska, Registrar of Titles
By: [Signature]
Deputy Registrar of Titles

Edward M. Treska
County recorder
By: GKE



LAND SURVEYORS • CIVIL ENGINEERS
LAND PLANNERS • LANDSCAPE ARCHITECTS

2422 Enterprise Drive
Mendota Heights, MN 55120
(612) 681-1914 FAX: 681-9488
625 Highway 10 N.E.
Blaine, MN 55434
(612) 783-1880 FAX: 783-1883

TPC FIRST ADDITION

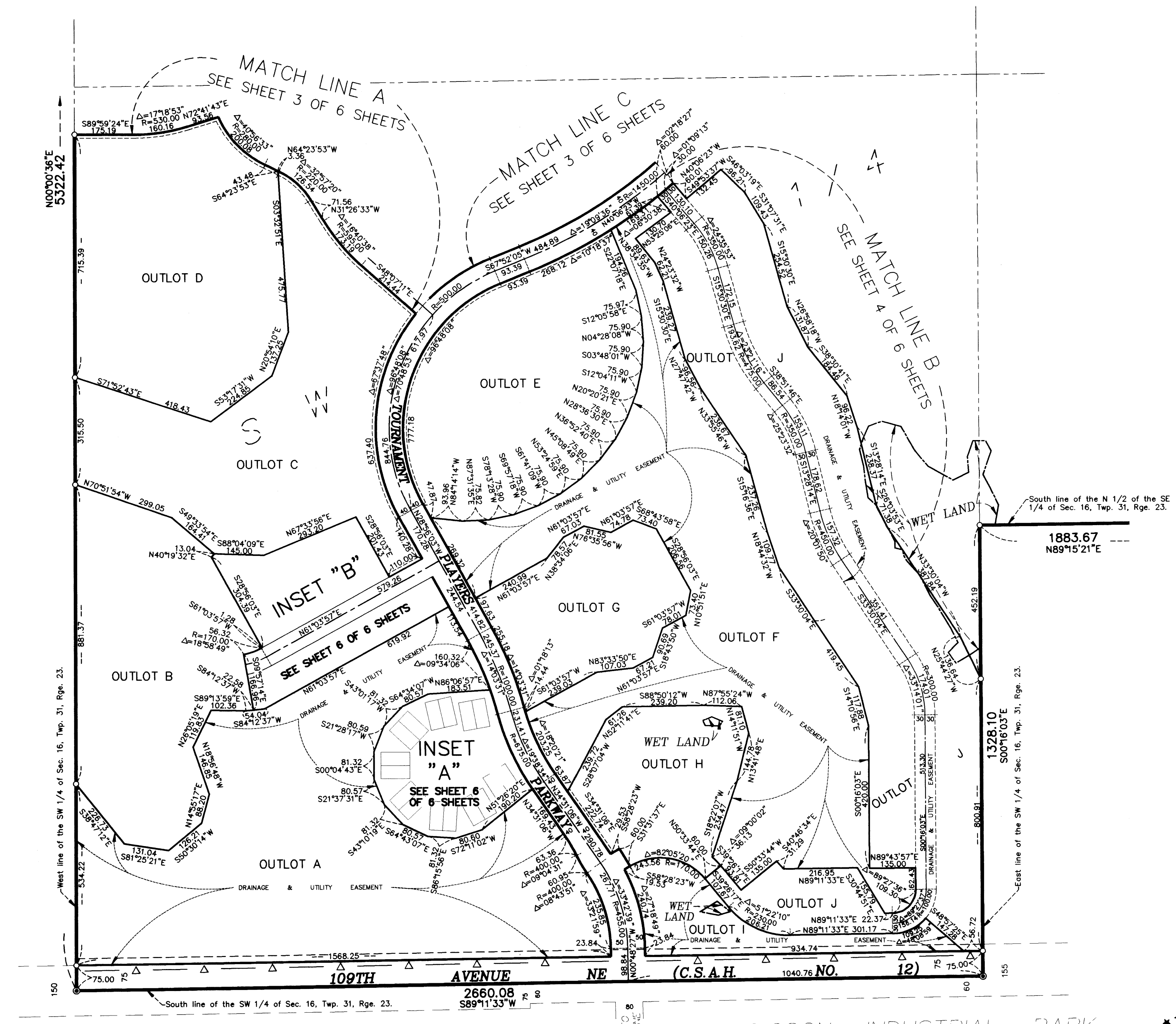

DRAINAGE AND UTILITY EASEMENTS ARE SHOWN THUS:

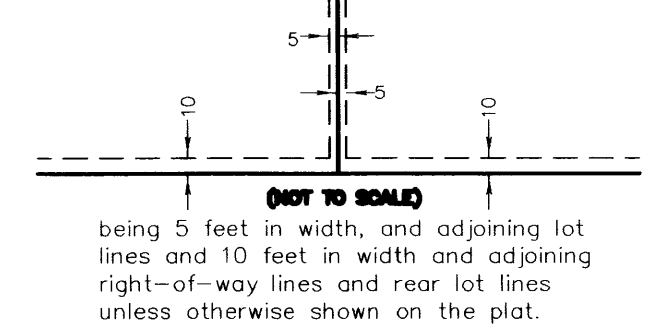

All monuments required by Minnesota Statute, and not shown on this plat, will be set within one year of the recording date of this plat, and shall be evidenced by a 1/2 inch by 1/4 inch iron pipe marked by RLS 20595.

- Δ — Denotes right of access dedicated to Anoka County
- Denotes cast iron monument.
- Denotes found iron monument.
- Denotes 1/2 inch by 1/4 inch iron monument set and marked by license no. 20595

For the purposes of this plat, the west line of Sec. 16, T. 31, R. 23 is assumed to have a bearing of N 00°00'36" E.

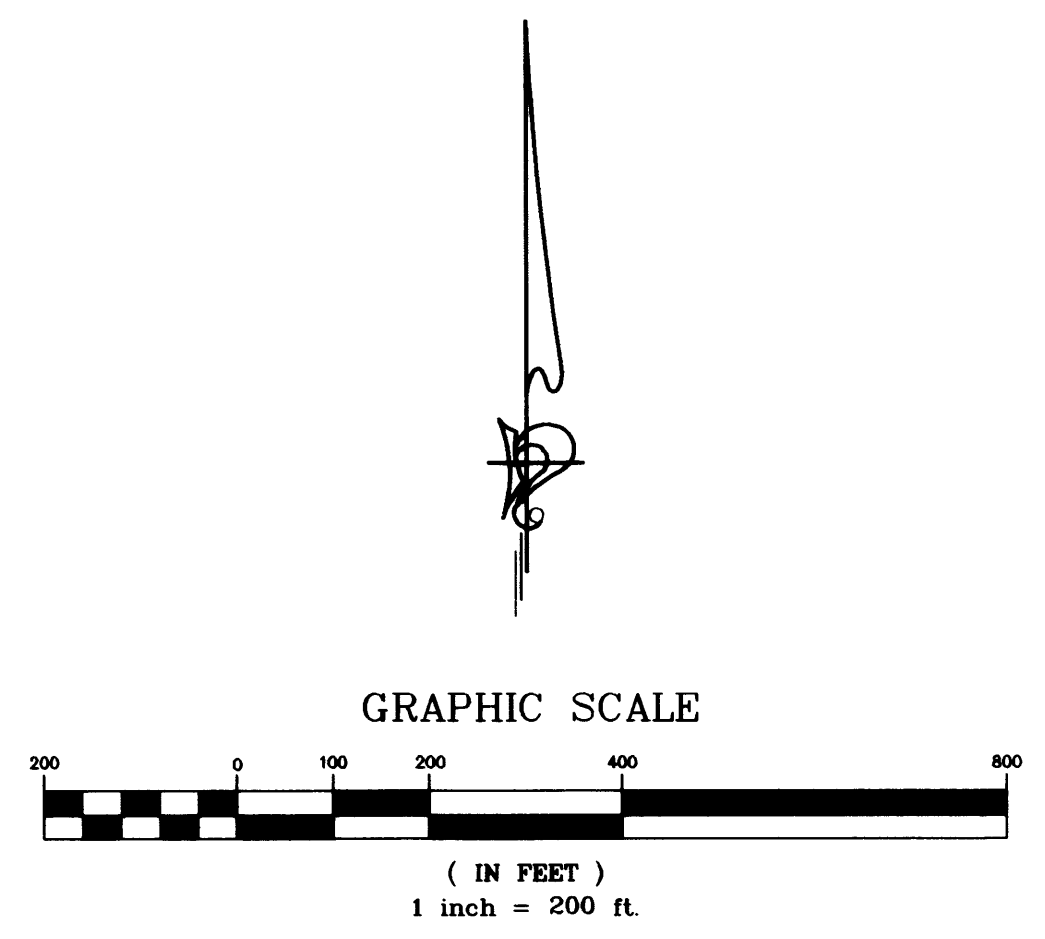

RADISSON INDUSTRIAL PARK

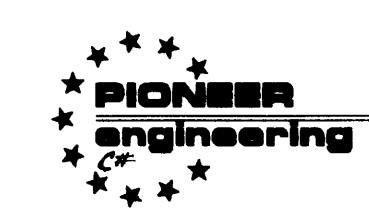

LAND SURVEYORS • CIVIL ENGINEERS
LAND PLANNERS • LANDSCAPE ARCHITECTS

2422 Enterprise Drive
Mendota Heights, MN 55120
(612) 681-1914 FAX: 681-9488
625 Highway 10 N.E.
Blaine, MN 55434
(612) 783-1880 FAX: 783-1883

TPC FIRST ADDITION

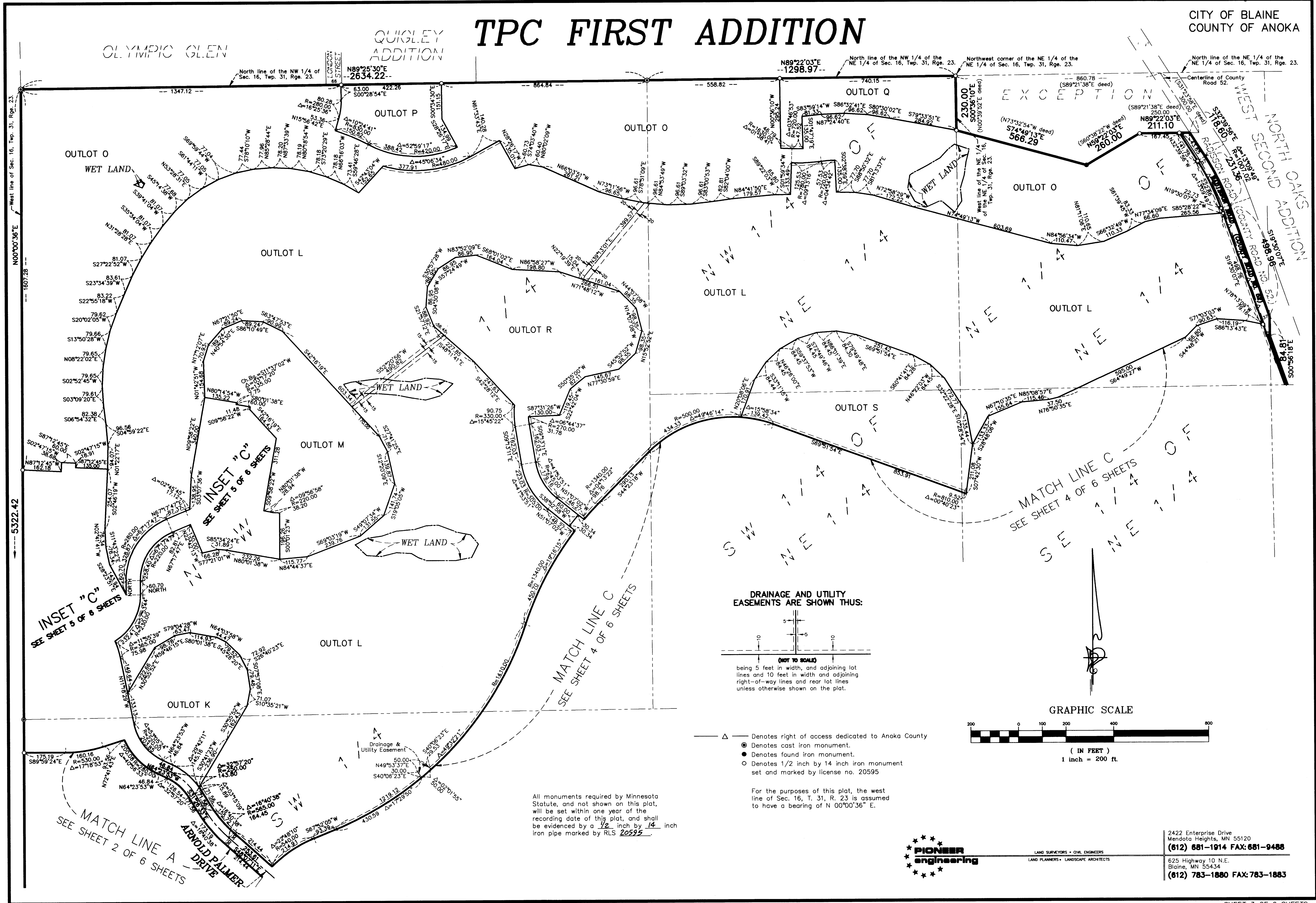

TPC FIRST ADDITION

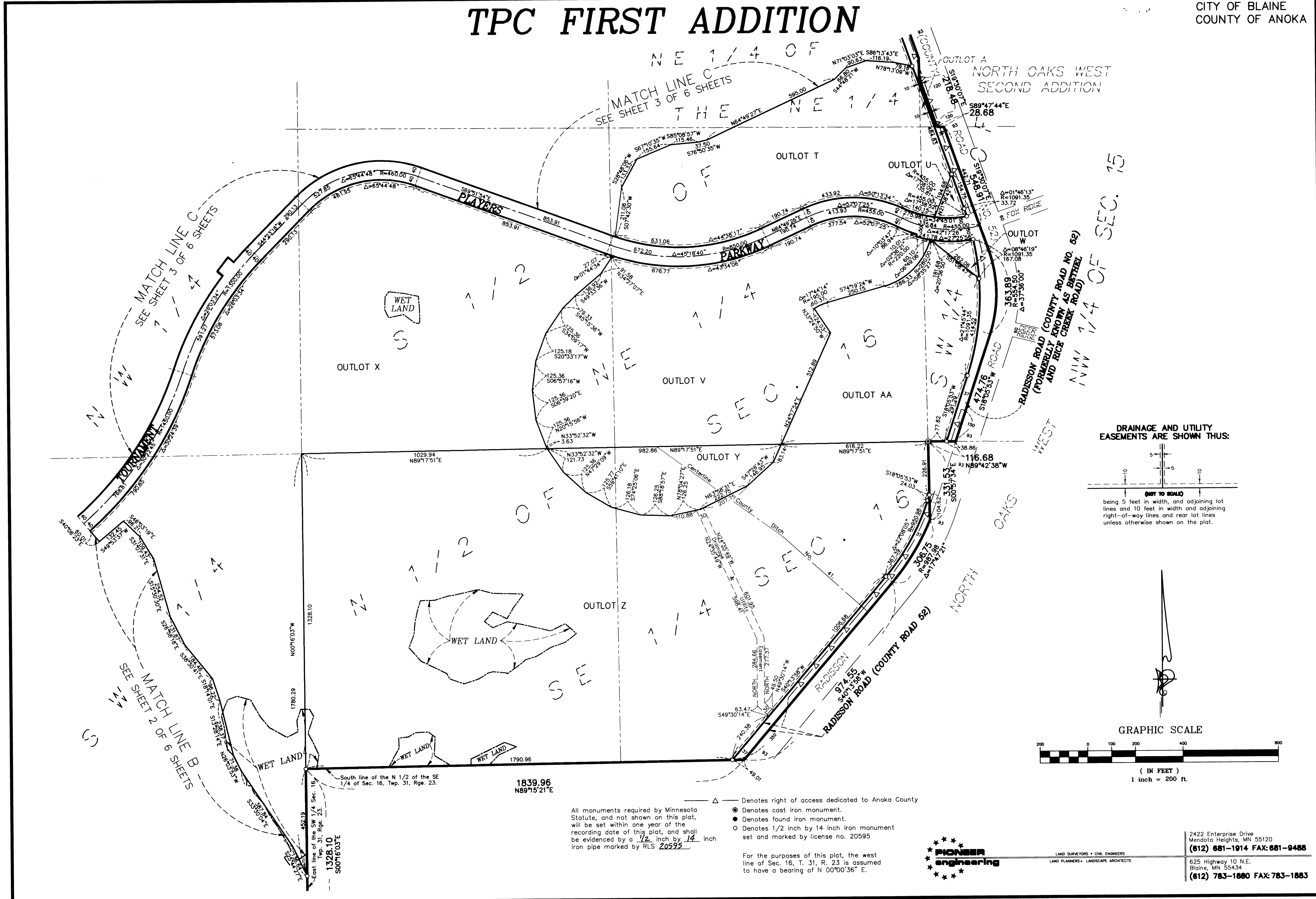

DRAINAGE AND UTILITY EASEMENTS ARE SHOWN THUS:

(NOT TO SCALE)
being 5 feet in width, and adjoining lot lines and 10 feet in width and adjoining right-of-way lines and rear lot lines unless otherwise shown on the plat.

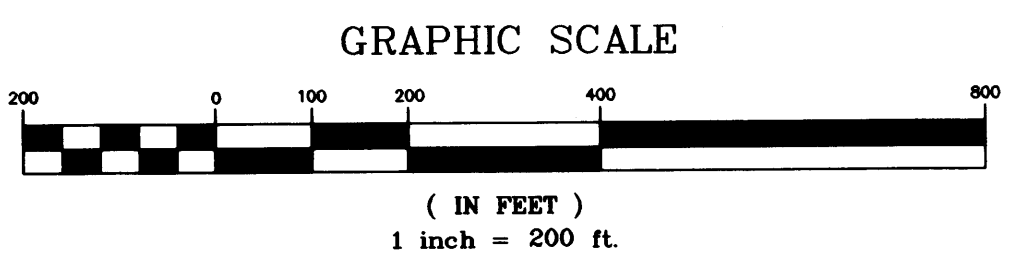

— Δ — Denotes right of access dedicated to Anoka County Statute, and not shown on this plat, will be set within one year of the recording date of this plat, and shall be evidenced by a 1/2 inch by 14 inch iron pipe marked by RLS 20592

● Denotes cast iron monument.
● Denotes found iron monument.
○ Denotes 1/2 inch by 14 inch iron monument set and marked by license no. 20595

For the purposes of this plat, the west line of Sec. 16, T. 31, R. 23 is assumed to have a bearing of $N 00^{\circ}00'36'' E$.



LAND SURVEYORS • CIVIL ENGINEERS
LAND PLANNERS • LANDSCAPE ARCHITECTS

2422 Enterprise Drive
Mendota Heights, MN 55120
(612) 681-1914 FAX: 681-9488
625 Highway 10 N.E.
Blaine, MN 55434
(612) 783-1880 FAX: 783-1883

TPC FIRST ADDITION

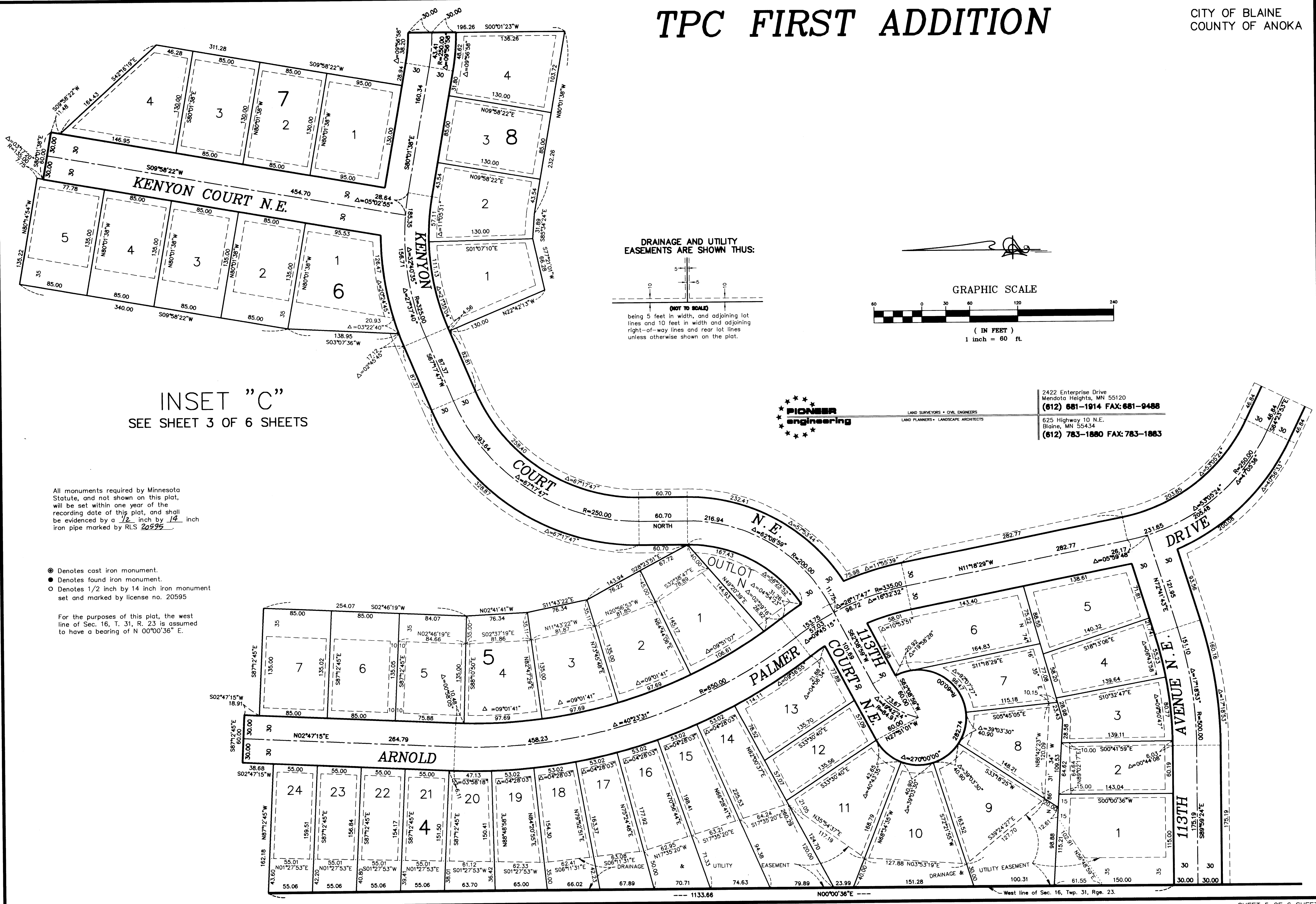

INSET "C"
SEE SHEET 3 OF 6 SHEETS

DRAINAGE AND UTILITY EASEMENTS ARE SHOWN THUS:

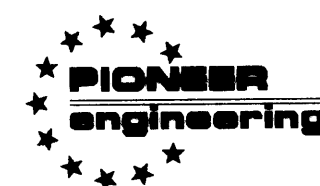
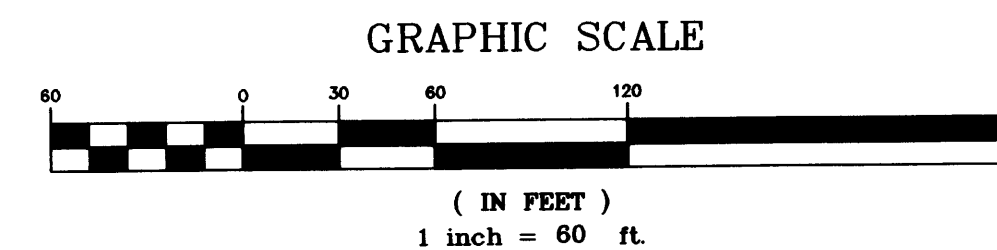
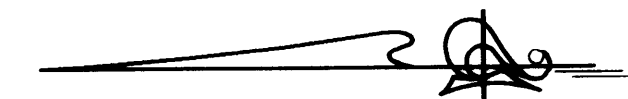
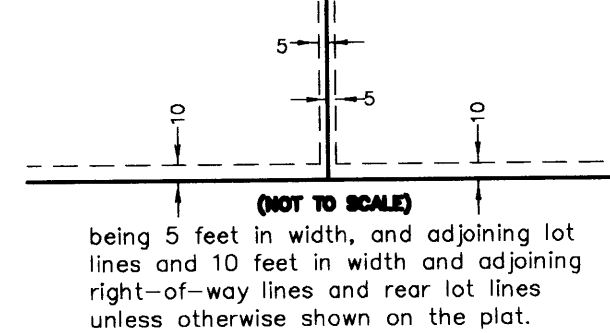

LAND SURVEYORS • CIVIL ENGINEERS
LAND PLANNERS • LANDSCAPE ARCHITECTS

2422 Enterprise Drive
Mendota Heights, MN 55120
(612) 681-1914 FAX: 681-9488
625 Highway 10 N.E.
Blaine, MN 55434
(612) 783-1880 FAX: 783-1883

All monuments required by Minnesota Statute, and not shown on this plat, will be set within one year of the recording date of this plat, and shall be evidenced by a 1/2 inch by 1/4 inch iron pipe marked by RLS 20595.

- ⊙ Denotes cast iron monument.
- Denotes found iron monument.
- Denotes 1/2 inch by 1/4 inch iron monument set and marked by license no. 20595

For the purposes of this plat, the west line of Sec. 16, T. 31, R. 23 is assumed to have a bearing of N 00°00'36" E.

TPC FIRST ADDITION

INSET "B"
SEE SHEET 2 OF 6 SHEETS

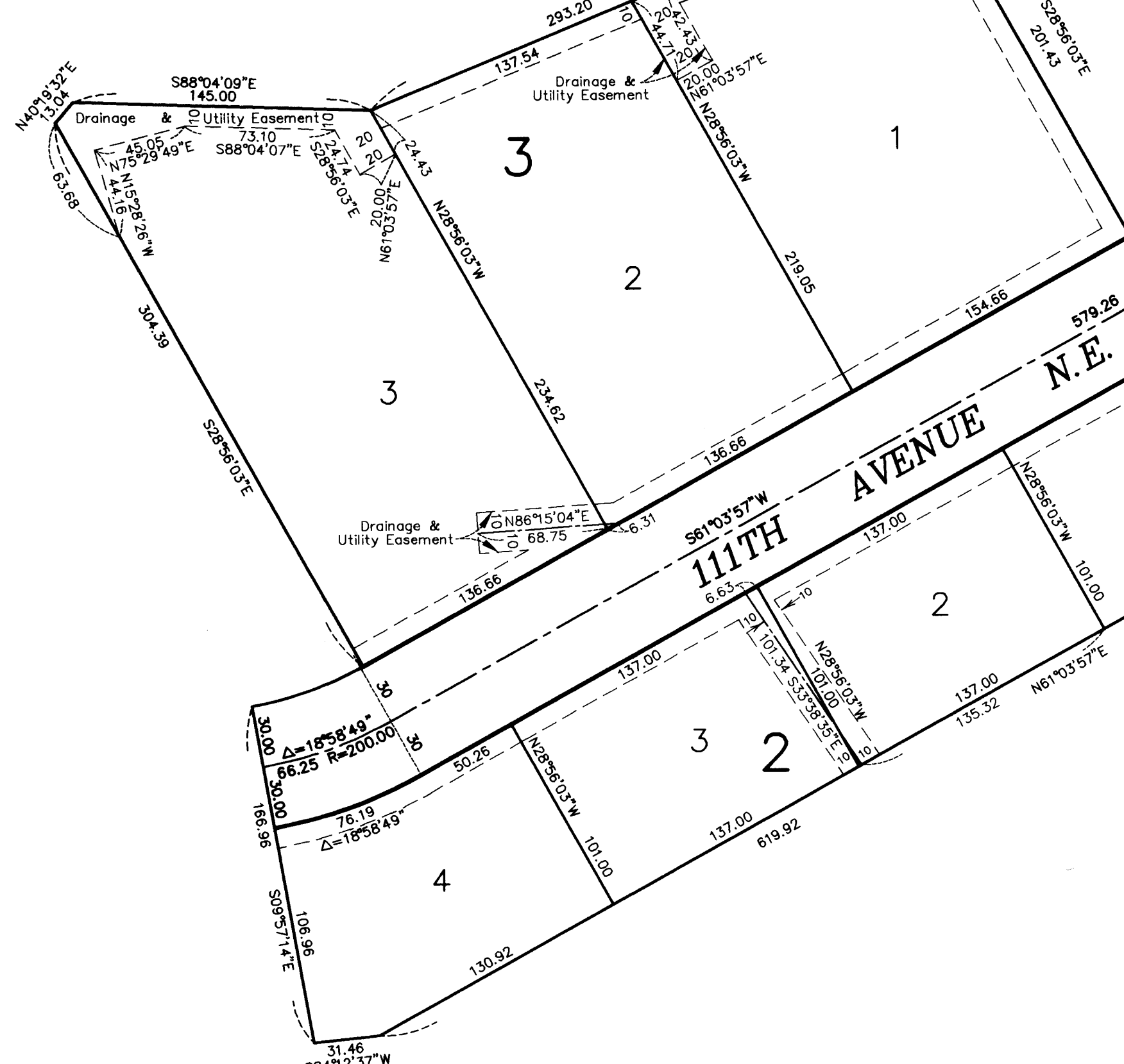

DRAINAGE AND UTILITY EASEMENTS ARE SHOWN THUS:

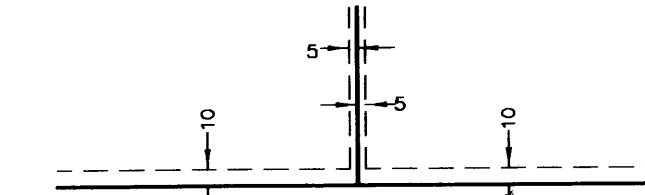

(NOT TO SCALE)
being 5 feet in width, and adjoining lot lines and 10 feet in width and adjoining right-of-way lines and rear lot lines unless otherwise shown on the plat.

All monuments required by Minnesota Statute, and not shown on this plat, will be set within one year of the recording date of this plat, and shall be evidenced by a 1/2 inch by 1/4 inch iron pipe marked by RLS 20595.

- Denotes cast iron monument.
- Denotes found iron monument.
- Denotes 1/2 inch by 1/4 inch iron monument set and marked by license no. 20595

For the purposes of this plat, the west line of Sec. 16, T. 31, R. 23 is assumed to have a bearing of N 00°00'36" E.

INSET "A"
SEE SHEET 2 OF 6 SHEETS

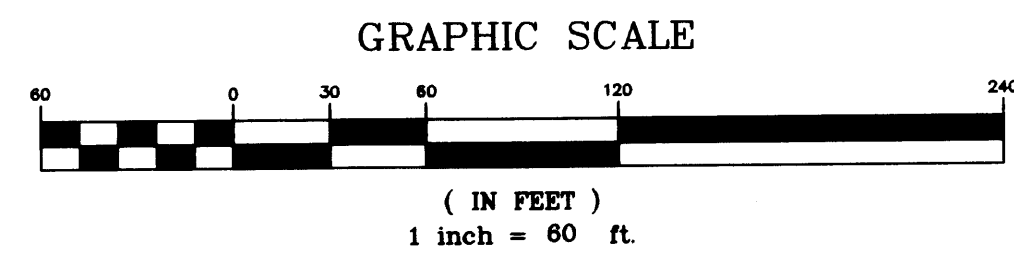
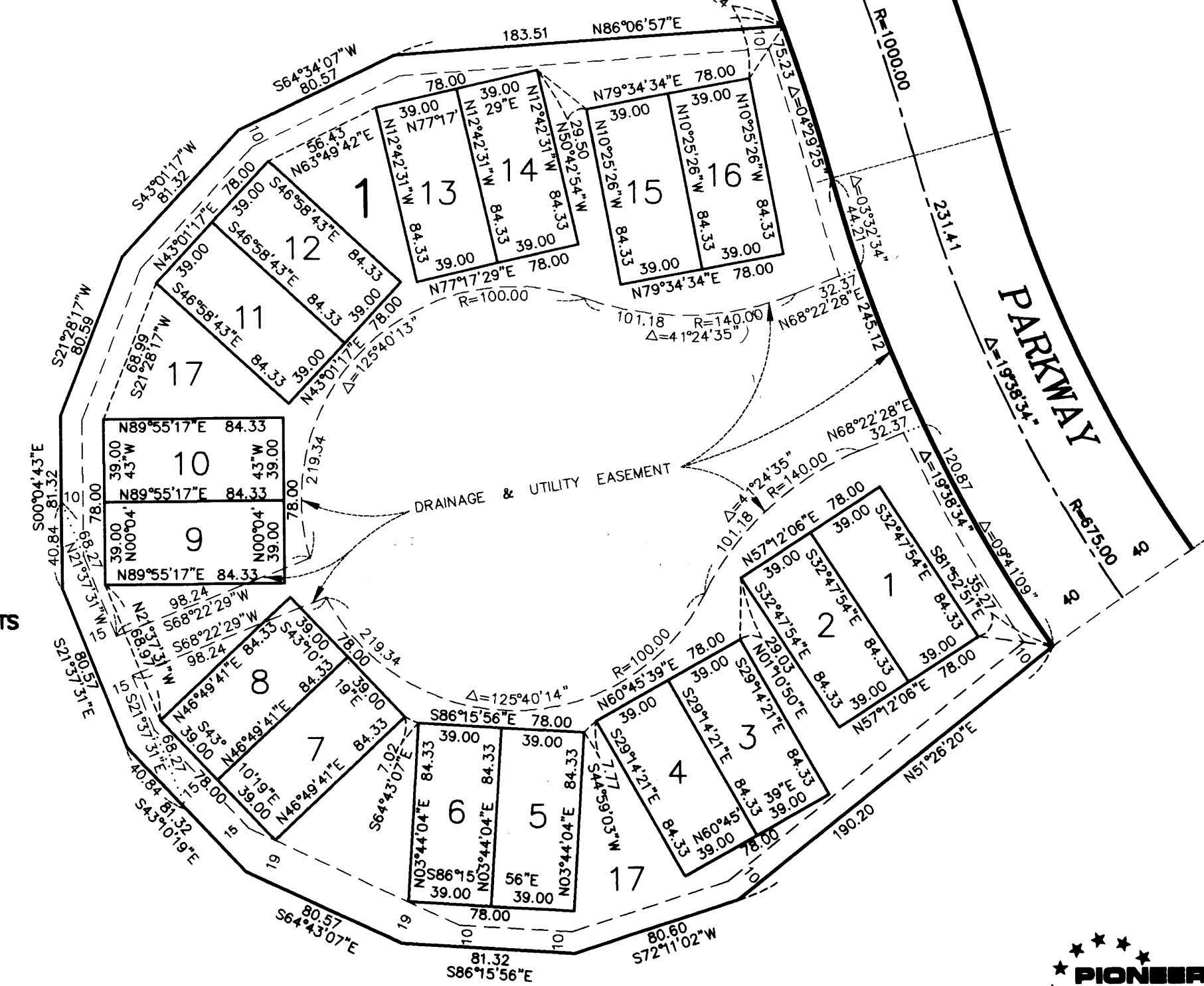

LAND SURVEYORS • CIVIL ENGINEERS
LAND PLANNERS • LANDSCAPE ARCHITECTS

2422 Enterprise Drive
Mendota Heights, MN 55120
(612) 681-1914 FAX: 681-9488
625 Highway 10 N.E.
Blaine, MN 55434
(612) 783-1880 FAX: 783-1883